



MACHINING -LEVEL II

Based on Version 2 February 2017

Occupational Standard (OS)

Training Module –Learning Guide 35-37

Unit of Competence: Carry out Heat treatment
Module Title: - Carrying out Heat treatment

TTLM Code: IND MAC2 TTLM11 1019v1

October 2019



Module Title: - Carrying out Heat treatment

TTLM Code: IND MAC2 TTLM11 0919

This module includes the following Learning Guides

LG 35: Prepare for work

LG Code: IND MAC2 M11 LO1 LG- 35

LG 36: Operate heating equipments

LG Code: IND MAC2 M11 LO2 LG- 36

LG 37: Quality assurance and clean -up

LG Code: IND MAC2 M11 LO3 LG- 37



Instruction Sheet	Learning Guide #35
--------------------------	---------------------------

This learning guide is developed to provide you the necessary information regarding the following **content coverage** and topics –

- Determining work requirements
- Selecting Heating equipment as heat treatment process
- Select equipment to standard operating procedures
- Use Personal protective equipment/devices

This guide will also assist you to attain the learning outcome stated in the cover page. Specifically, upon completion of this Learning Guide, **you will be able to –**

- Determine work requirements from engineering drawing, job sheet or verbal instructions
- Select heating equipment for the required heat treatment process.
- Select equipment is according to standard operating procedures and/or manufacturer's instructions
- Use personal protective equipment/devices in accordance with Occupational Health and Safety (OHS) requirements

Learning Instructions:

1. Read the specific objectives of this Learning Guide.
2. Follow the instructions described below.
3. Read the information written in the “Information Sheets”. Try to understand what are being discussed. Ask your trainer for assistance if you have hard time understanding them.
4. Accomplish the “Self-checks” which are placed following all information sheets.
5. Ask from your trainer the key to correction (key answers) or you can request your trainer to correct your work. (You are to get the key answer only after you finished answering the Self-checks).



1.1. Introduction

Heat Treatment can be defined as a combination of heating and cooling operations applied to metals and alloys in the solid state to obtain desired microstructure conditions or predetermined properties (physical, mechanical). Heat treatments are most commonly applied in metallurgy, aircraft industry, automobile manufacturing, defense sector, forming, foundry, heavy machinery manufacturing and powder metal industry. The process of altering the physical, chemical, and mechanical properties of a metal by applying controlled heating and cooling is known as heat treatment. It is a procedure that is applied to improve or restore a product's manufacturability. Heat treatments are most commonly applied in metallurgy, manufacturing, hot forming, welding, etc. The usual methods of heat-treating processes ferrous metals (metals with iron) are annealing, normalizing, hardening, tempering and others. Most nonferrous metals can be annealed, but never tempered, normalized, or case-hardened.

Thermal treatments of metallic alloys are also employed to alter the surface chemistry of a material. This is achieved by diffusing Carbon, Nitrogen and other gaseous or solid material in to the surface of the component. These processes are used to give defined surface hardness and to improve wear, corrosion and fatigue resistance. In general three kinds of treatments are: (i) Thermal (heat treatment), (ii) Mechanical (working), (iii) Chemical (alteration of composition). Combinations of these treatments are also possible (e.g. thermo-mechanical treatments, thermo-chemical treatments). Heat treating operations consist of three separate functions: material movement, the application of energy, and the supervision of process conditions. Heat treaters is that the same flexibility that allows us to manipulate the end result of a heat treatment, tests our ability to control and repeat our processes to achieve our customer's desired product performance time after time.

1.2. Principles of Heat Treatment of steel

- Materials are never heated to the melting point in heat treatment.
- Therefore, all reactions within the metal during the heating and cooling cycle, takes place while the metal is in the solid state.
- During ordinary heating operations, steel is seldom heated above 983 °C.
- In using the iron-iron carbide diagram, we need only to concern ourselves with that part which is always solid steel.
- The area where the Carbon content is 2% or less and the temperature is below 1130°C.



1.3. Purpose of Heat Treatment processes

Metal and alloys are heat treated for a number of purposes to:

- To increase strength, hardness and wear resistance (Bulk hardening, Surface hardening)
- To increase ductility and softness (Tempering, Recrystallization Annealing)
- To increase toughness (Tempering, Recrystallization Annealing)
- To obtain fine grain size (Recrystallization Annealing, Full annealing, Normalizing)
- To remove internal stress induced by different deformation by cold working, non-uniform cooling from high temperature during casting and welding (Stress relief annealing)
- To improve machinability (Full annealing and Normalizing)
- To improve cutting properties of tool steels (Hardening and Tempering)
- To improve surface properties (Surface hardening, high temperature resistance-precipitation hardening, surface treatment)
- To improve electrical properties (Recrystallization, Tempering, age hardening)
- To improve magnetic properties (Hardening, Phase transformation)

1.4. Determining work requirements

In manufacturing workshop in order to produced the required work (as customer need). Worker or heat treating operator has to perform some operations. It is important that the sequence of operations be carefully planned in order to produce a part quickly and accurately. Following a wrong sequence of operation can often result in spoiled work. The best methods of job planning is first interpret the instruction of the given job sheet or verbal instructions correctly, and arrange the sequence of heat treating line operation to plan technically to obtain the given components to the required properties.

Interpretation

Interpretation means reading and understanding the information given points engineering drawing, job sheet or verbal instructions; Reading, interpreting and following information on written job instructions, specifications, standard operating procedures, manufacturers manual and instructions, chart, list, drawings and applicable reference documents as organizational / company rule and regulation.

Operational sequences line

It is a sequence of heat treating operation plan. Which is prepared based on the information provided on the job sheet or verbal instructions of the component to be heat treated has to ready for producing expected parts / components / with required properties of metals.



Self-Check -1	Written Test
----------------------	---------------------

Directions: Answer all the questions listed below. Use the Answer sheet provided in the next page:

1. The first activities to do works, job sheet or verbal instructions to heat treatment workshop
 - A. Read and understand work requirements
 - B. Apply sequence of heat treating operation
2. To make a product of desired properties on heat treatment operation operator has to
 - A. Interpret work as needed
 - B. Prepare sequence of heat treating techniques

Note: Satisfactory rating - 3 points

Unsatisfactory - below 3 points

Answer Sheet

Score = _____
Rating: _____



Information Sheet-2	Selecting Heating equipment as heat treatment process
----------------------------	--

2.1 Introduction to Heat treatment process

Heat treatment is operation is an operation or combination of operations involving heat a specific rate, soaking at temperature for a period of time and cooling at some specified rate. The aim is to obtain a desired microstructure to achieve certain predetermined properties (physical, mechanical, magnetic or electrical).

2.2. Types of Heat Treating Furnaces

Sizes and designs of heat treating furnaces vary over such a wide range that any precise classification is virtually impossible. In size, furnaces vary from a small model that sits on a bench and has a work space capacity for only a few ounces (often used for heat treating instrument parts) to a large car-bottom furnace that is capable of handling hundreds of tons in a single heat. Regardless of size, furnaces may be directly fired with fuel, where the work is exposed to combustion gases, or indirectly fired where the work is separated from combustion gases. Furnaces may also be heated by electrical resistance.

2.3. Selecting Heating equipment

The choice of heat treating equipment varies with application. Selecting the right style and type of equipment will ensure the highest quality product. Often times a number of furnace types can do the job, so the choices come down to economy of operation. who to dedicate staff to this endeavor may wish to consider batch equipment or continuous processing or look at outsourcing to qualified commercial heat treaters. Other shops need to evaluate which technology is the best fit to their product mix and skill sets. The most common heat treatments performed in furnaces are annealing, normalizing, tempering, spheroidizing, carburizing, stress relieving, etc. On furnaces generally depends on the size of the load, the pressure and temperature to be attained, and the medium (oil or gas) to be used in cooling the load.

Ovens and Furnaces

The Industrial Heating Equipment Association (IHEA) classifies heating devices as ovens and furnaces. This separation, based on operating temperature, is related directly to heating mode.

Modes of Heat Transmission

The three basic modes of heat transmission are conduction, convection, and radiation. In industrial heat treating, these modes may be used singly, or in combination.

Page 7 of 105	Federal TVET Agency Author/Copyright	TVET program title- Machining Level -2	Version -1 October 2019
---------------	---	--	----------------------------



Conduction of heat in a solid such as a metal work piece is the transfer of heat from one part of the solid to another, under the influence of a temperature gradient and without appreciable displacement of the particles. For instance, if the temperature of the surface of a part is elevated, the heat flow to the center is by a molecular mechanism. Conduction involves the transfer of kinetic energy from one molecule to another in a chain reaction. Heat flow continues until equilibrium occurs. The time involved depends on the conductivity of the given metal, but in general, the speed of conduction within metals is relatively fast.

Convection involves the transfer of heat by mixing one parcel of fluid (fluid refers to either liquid or gas) with another. The motion of the fluid may be entirely the result of density differences resulting from temperature difference, as in natural convection, or it may be produced by mechanical means, as in power convection. Fans commonly are used to increase the overall heat transfer coefficient of the system. A hot-air home heating system is an excellent example of heating by convection. Tempering of steel is a common application of convection heating in heat treating.

Radiation. A body emits radiant energy in all directions by means of electromagnetic waves, the wavelength ranging from 4 to 7 μm . When this energy strikes another body, some of the energy is absorbed, raising the level of molecular activity and producing heat. Some of the energy is reflected. The amount absorbed depends on the emissivity of the surface of the receiver. The sender gives up heat or energy. On this basis, if two pieces of metal, one hot and one cold, are placed in a completely insulated enclosure, the hot piece cools and the cold one is heated. The exchange of energy takes place until both objects come to equilibrium or to the same temperature level. Even after equilibrium of temperature is established, the process continues with each piece radiating and absorbing energy from each other.

Classification of Furnaces by Heat Transfer Medium

One means of classifying heat treating furnaces is by the type of heat transfer medium employed; this classification method is valid regardless of size and most common variables of furnace components. The types of heat-transfer media are gaseous (air or vacuum), liquid (molten metal or molten salt bath), or solid (as with fluidized bed furnaces). Many types and designs of heat treating furnaces, regardless of the mode of heat transfer or the medium employed for heat transfer, are available as standard models. When an existing predesigned and/or prebuilt model is suitable for specific customer requirements, the cost is naturally lower, because the engineering has been completed. In many instances, standard models may require minor factory modifications to meet specific customer requirements. This increases cost but seldom equals the cost of designing and building a custom furnace.

Page 8 of 105	Federal TVET Agency Author/Copyright	TVET program title- Machining Level -2	Version -1
			October 2019



Batch-Type versus Continuous-Type Furnaces

Batch-Type Furnaces. In some plants, heat treating furnaces are classified as batch or continuous types. A batch-type furnace refers to one that is loaded with a charge and then closed for the pre-established heating cycle. After completion of the heating cycle, the workload may be cooled in the furnace at a planned cooling rate (such as for annealing), removed, and cooled in still air (as in normalizing), or quickly cooled (quenching) as by immersion in oil or water.

Continuous furnaces may be any of many designs including their conveying mechanisms, but basically they portray an “in-one-end” and “out-the-other-end” type of unit. A continuous furnace is generally intended for continuous high production of similar parts or for parts requiring similar process cycles. The capabilities that can be designed into a continuous furnace are virtually limitless in terms of varied heat treating cycles.

In heat treatment workshop the commonly used types of heating equipment either oven or furnaces types. They are two types of furnace used, - Batch Furnace and – Continuous Furnace. Heating system sources of fuels used gas, oil and electricity.

Batch Furnace: - heating system in an insulated chamber, with a door for loading and unloading

- Production in batches
- Example:- pit furnace, box furnace, Boggine (car type) furnace, Muffle furnace , bell furnace, elevator furnace , etc.

Continuous Furnace:- generally for higher production rates

- Mechanisms for transporting work through furnace include rotating and straight through conveyors that provides a constant work load through the unit.

Roller-Hearth Continuous Furnaces, The charging end of a large continuous furnace. The work is conveyed through the furnace by means of rollers. The ends of the rolls project through the walls of the furnace to external air- or water-cooled bearings. Usually, the rolls are power driven by a common source through a chain and sprocket mechanism. Heat treating equipment is normally supplied in one of two main types: batch or continuous. The fundamental difference between these two style is not in the materials of construction, although there are differences due to inherent design requirements, but instead the key difference lies in how workloads are positioned in the units and how they interact within the furnaces.

Heat treating equipment can further be divided in to (**atmosphere and vacuum**) furnaces and ovens.

Atmospheric furnace:- Operated at ambient (atmosphere) pressure
 - Load is heated and cooled in presence of air special gases (process atmospheres), in liquid baths or in a fluidized bed.

Vacuum furnace:- Operated at vacuum or sub-atmospheric pressure.
 - May involve high pressure gas cooling using special gases.
 - Includes iron or plasma processing equipment.

Batch Furnaces for Heat Treatment of Steel: 7 Types

The following points describe the seven main types of batch furnaces used for heat treatment of steel. The types are: 1. Box-Type Batch Furnace of Steels, 2. Bogie-Hearth Furnace of Steels, 3. Muffle Furnace of Steels 4. Pit Furnace (Vertical Furnace) of Steels 5. Bell Furnaces of Steels, 6. Salt Bath Furnaces of Steels and 7. Fluidized-Bed Furnaces of Steels.

Type # 1. Box-Type Batch Furnace:

The simplest of the box-type has an opening (door) at one face just as in a box, and that is why it is named so. The furnace chamber is commonly rectangular in section. It is used for small and medium sized parts. Generally, loading and unloading (after the heat treatment) is done manually through this door. For heavy components, a zig-crane, or an overhead crane may be used. As show below fig. 1.

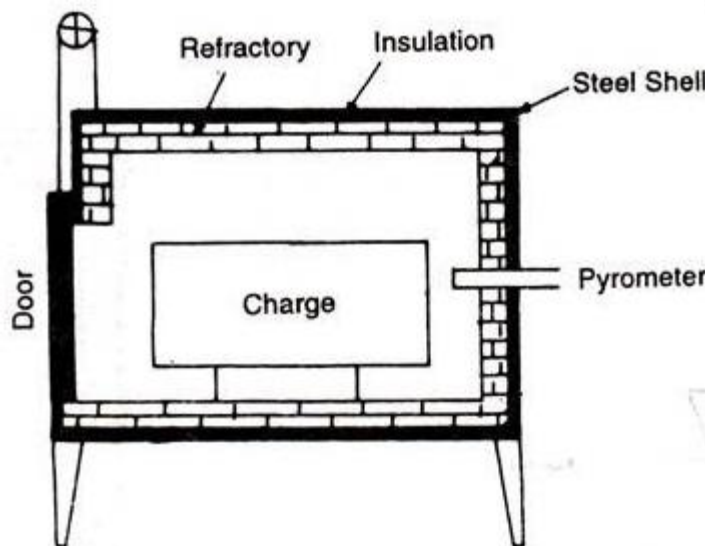

Fig. 1 . Box-type furnace.

Box-type furnaces are quite flexible, and can be used for annealing, pack-carburising, and hardening of low alloy steels. The furnace should be used to its full capacity to drive the maximum advantages.

Though such furnaces can be heated by a fuel, but commonly electric resistance heating is done. The resistance wire in the form of coil is placed inside the refractory

(high alumina) grooves. A thermocouple fitted through the rear wall of the chamber is connected to a pyrometer to automatically control the temperature. Now a days, to facilitate the loading and unloading, a detachable and movable bottom, which is rolled into position underneath the furnace and raised into the furnace by motor-driven mechanisms, after putting the charge on the hearth, is used. Such a furnace is called 'Elevator-type' furnace. Large and heavy loads can be handled, and can be cooled rapidly by high velocity gas system internally or externally such as for solutionising treatment of precipitation hardenable type non-ferrous alloys.

Type # 2. Bogie-Hearth Furnace:

It is a modified version of box-type batch furnace having a movable hearth mounted on wheels. This car-type hearth is moved out to load and unload (after the heat treatment) the charge. The car hearth with the loaded charge is put inside the furnace and then sealed with granular sand sealing troughs, or solid seals. Such furnaces are normally non-atmospheric controlled. The heating may be done by a fuel, or by electric resistance heating elements. It is also possible to use a programmed cycle here. On below figures 2.

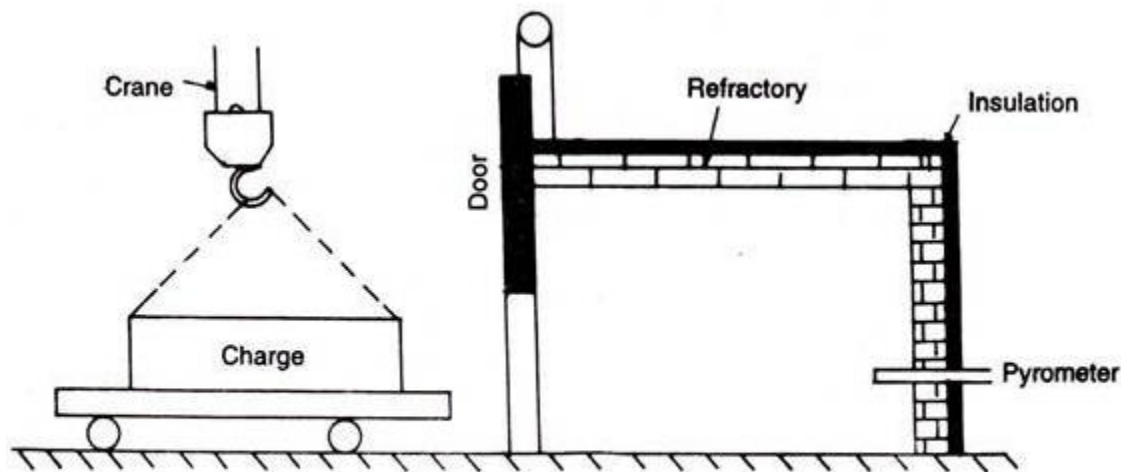

Fig. 2. Bogie-hearth (car bottom) furnace.

Normally bogie-hearth furnaces are used in temperature range of 540°C to 1100°C such as for stress- relieving, annealing, hardening of components. It is commonly used for heat treating bulky and heavy components although it can also be used for small components

Type # 3. Muffle Furnace:

A muffle is a hollow cuboid or cylindrical retort made of special refractory material, or non-scaling steel. A furnace, in which the heat source does not directly make contact with the material being heat-treated, is described as a muffle furnace. The components



are charged in a muffle, and gas firing, or electrical energy can be used to heat the muffle from outside.

The gas is burnt outside the muffle, and the heating is effected by the hot gases which are made to circulate through the ring like space between the interior-wall and the exterior-muffle wall.

The products of combustion of the gas do not enter the heating chamber (the muffle), and thus, the atmosphere of the furnace can be controlled, and thus, scaling of the components can be prevented. Also, such a furnace gives reasonable uniformity of temperature distribution. Fig. 3 illustrates such a furnace schematically. Gas carburising of small parts such as parts of cycle-chain is carried out in a non-scaling steel retort (muffle) revolving around the horizontal axis.

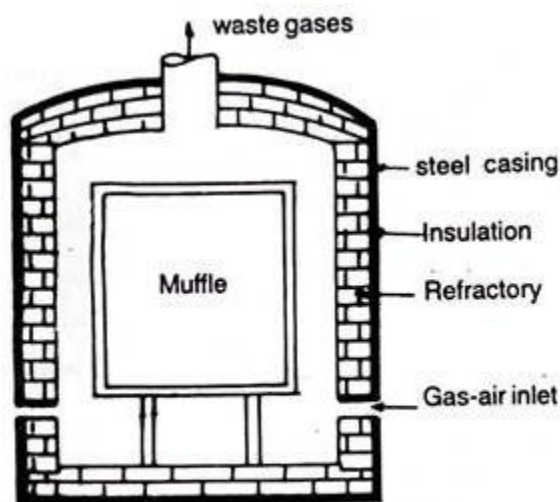

Fig. 3 Gas-fired muffle furnace.

Commonly, electrically heated muffle furnaces are extensively used for the heat treatment of small sized components. Fig.3. illustrates heating element like nichrome or kanthal wire wound around the muffle, or are placed in the ring-like space to heat the muffle with its contents. For high temperatures, electric muffle is heated by glow bars, or radiant elements, where the steel gets heated by direct radiations. Muffle furnaces are used for bright annealing, nitriding, carburising, bright hardening.

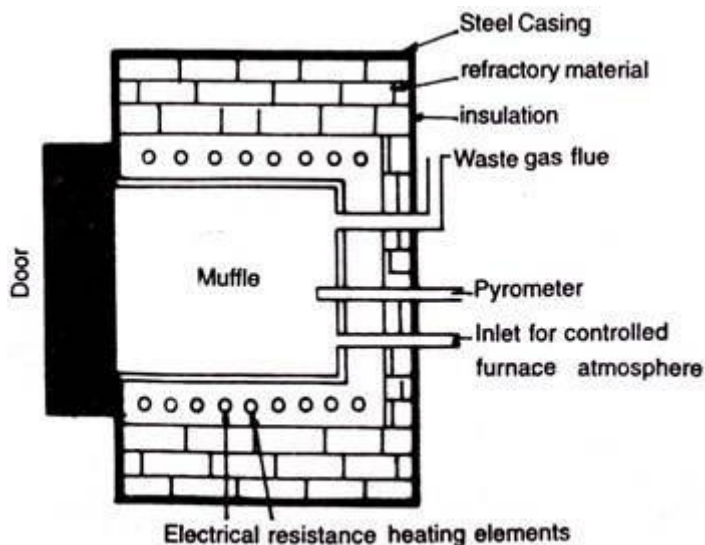

Fig. 10.3. Electric muffle furnace.

There are two main types of muffle batch-type furnaces, depending on the design. A horizontal type is illustrated in figures 2 and 3. The second type is a vertical muffle pit furnace. (Fig. 4)

Type # 4. Pit Furnace (Vertical Furnace):

A pit furnace consists of the furnace placed in a pit. The furnace extends to the shop-floor level or slightly above it. It has a cover or lid put on top of the furnace. The long and slender parts such as tubes, spindles, shafts, rods, etc. are suspended from suitable fixtures from top, or may be supported from the lower end to remain in vertical position. Heating in such a manner reduces distortion and war page.

The components can be put on the bottom hearth of the furnaces for heating or held in a basket inside the furnace (Fig. 4). The non-scaling steel retort can help high degree of control of atmosphere. Fans promote both uniformity of temperature as well as gas composition. Fig. 4 furnace is used for gas car burising or other case-hardening treatments.

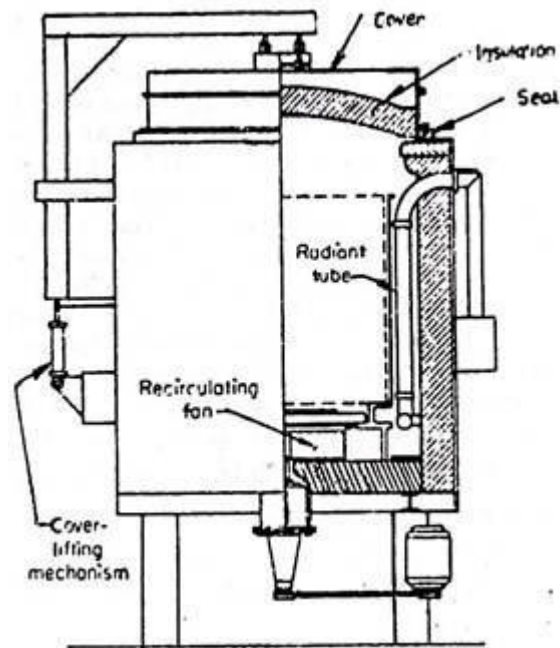

Fig. 4 Muffle pit furnace

A Pit furnace may not have a muffle. Pit furnaces are particularly suited for parts to be cooled in the furnace. Direct quenching particularly with large charge and in a large furnace is not feasible. Not only that the temperature may fall during opening of lid, the brief exposure to atmosphere results in the formation of adhering black scale.

To avoid this formation, horizontal type batch furnace with provisions of quenching under a cover of protective atmosphere is used. Pit furnace is cheaper and gives a better pay load-cost ratio, particularly suiting long slender components.

Type # 5. Bell Furnaces:

Bell furnaces have removable covers, called 'bells'. The charge is put on a hearth, and on top of it is put a retort (Fig. 5 c), which is sealed at the bottom with sand, etc. The supply of the protective gas is constantly given to inside of this sealed retort for continuous protection.

An outer 'bell'-shaped container having the heating elements fitted on inner wall is lowered to cover such an assembly as being done in Fig. 5 (b) and finally looks like as in Fig. 5 (a). The heating of the charge is done in controlled protective gas atmosphere for the required length of the time.

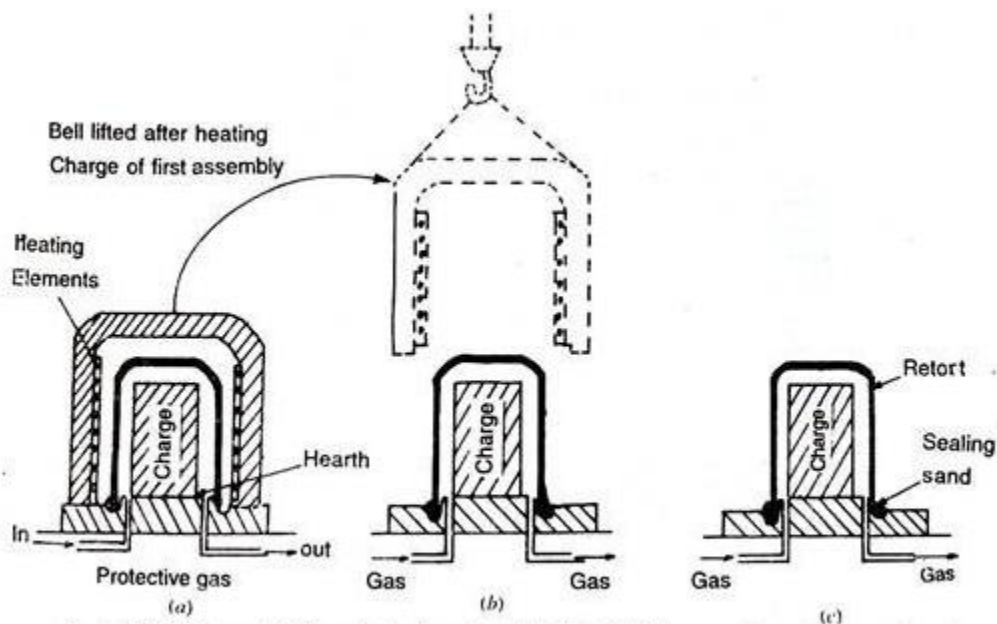

Fig. .5. Bell Furnace (a) Charge being heated by the bell, (b) Bell in removed from first assembly and being put on second assembly, (c) Third assembly ready.

After heating the first charge, the bell is taken off and is put on another assembly and the heating is then done of the second assembly for the required time. Mean-while, the first assembly and its charge cools under the protective atmosphere as the gas is constantly being fed in and out of the sealed retort. The hearth could be rectangular, or circular. One bell can take care of several retort assemblies. Fans may be provided inside the hearth assembly for rapid heating and uniformity of temperature. Temperature could be controlled by having thermocouples, automatic temperature controllers. As the heating bell shifts after completion of heating of one assembly to another, it leads to economic heating procedure as the heating bell is not continuously cooled and reheated. This procedure needs more floor space and overhead cranes, etc. Bell furnace is used for bright annealing, nitriding, bright normalising, ion-nitriding stress relieving, etc.

Type # 6. Salt Bath Furnaces:

Molten salt bath furnace essentially consists of an oval or rectangular container made of steel, cast iron, or a refractory pot which holds the molten salts. The pot is heated to and maintained at the required heat treating temperature either by the combustion of a fuel (fuel oil, or gas), or by electrical resistors. Electrically heated salt bath furnaces are much more common in use, now-a-days. Refractory pots are preferred for use with the neutral salts (free from cyanides or carbonates). Steel or cast iron pots are suitable for other salts used for cyaniding, or liquid carburising, etc. The mode of heat transfer to the charge is mainly by convection through the liquid bath. As the molten salt bath comes in best intimate contact with the charge, the heat transfer to the charge is very quick. Moreover, the molten salts possess high heat capacity resulting further in very



fast heating up of the charge as compared to air furnaces (around five times). Thus, the heat treatment time is drastically reduced resulting in good economy.

Salt bath furnaces can be used in a very wide range of temperatures from 150°C to 1300°C depending on the salt mixture used and the heat treatment requirements such as from tempering to hardening of high speed steels, including cyaniding, liquid carburising, liquid nitriding, austempering, martempering. The temperatures of the bath can be controlled within plus or minus 5°C. These furnaces are most commonly used for small and medium sized components particularly for mass heat treatment of parts.

Advantages of Salt Bath Furnaces:

Some of the advantages of salt bath furnaces are:

1. Because of better temperature control, all the components at a time are heated to the same uniform heat treatment temperature, resulting in highly reproducible properties.
2. There is no danger of oxidation and decarburization.
3. As the heating rate is high, heat treatment time is reduced.
4. Selective heat treatment can be done by immersing only the desired section of the components in the molten salt bath.
5. Different shapes, sizes of variable section thicknesses of light and heavy parts can be given heat treatment simultaneously with different heat treatment times at the same heat treatment temperature.
6. Desired furnace atmosphere can be obtained by properly selecting the salt mixture.
7. Initial cost of installation of such a furnace is very low.
8. The floor area and the maintenance required are minimal.
9. Worn-out electrodes can be easily replaced while the furnace is in operation, and does not need to be shut down for a long time.
10. Electrode-salt baths have higher heating efficiency, and much higher temperature can be attained. These furnaces are almost always used for heat treatment of high speed tool steels.
11. Temperature control $\pm 5^{\circ}\text{C}$ can be easily obtained.

Disadvantages of Salt Bath Furnaces:

1. High cost of pots which are to be replaced periodically.
2. Replacement of pots is quite time and labour oriented problem.
3. Pollution problems about fumes, but more critical the disposal of spent salts.
4. A large number of salt mixtures have cyanide as an important gradient. All necessary precautions have to be taken while using such salts. Proper ventilation, fume hoods, separates gloves, tongs etc. are required. Even otherwise too these salts are hazardous to labour working there.
5. A steel hardened in cyanide bath should not be tempered in a salt bath without completely removing any sticking salt otherwise violent explosion can occur.

Types of Salt Bath Furnaces:

There are three main types of salt bath furnaces:

- (i) Externally heated furnaces.
- (ii) Immersion heating element type furnaces.
- (iii) Immersed electrode type furnaces.

The externally heated salt bath furnaces could be fuel fired or electrical resistance wound salt bath furnaces. In both these, the pot or retort is heated from outside to bring it to the required heat treatment temperature. Fig. 6 illustrates schematic diagrams of these furnaces:

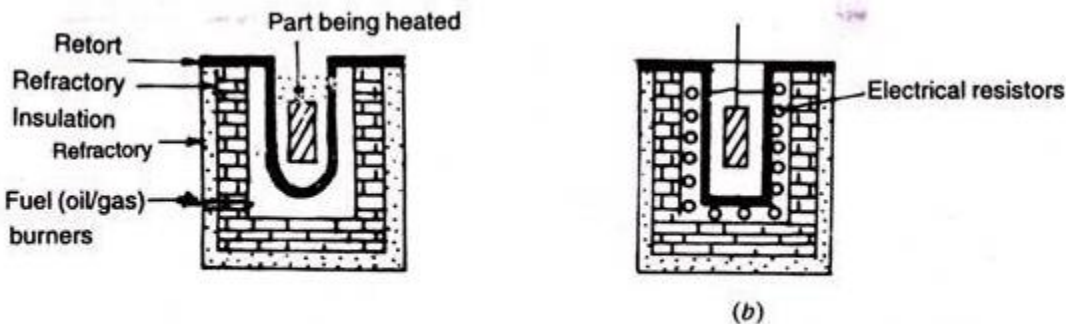

Fig. 6. Externally heated Salt bath furnaces. (a) Fuel-fired furnace. (b) Electrical resistance furnace

In the immersion heating element type salt bath furnaces, the heating element is immersed in the salt and remains there for heating, maintaining the temperature and even after shut down of the furnaces.

Immersed Electrode Type Salt Bath Furnace:

The most commonly used industrial salt bath furnace is the immersed electrode type furnace. It has molten salt bath with immersed electrodes to supply the power. The electrodes normally are of mild steels, or of steel having 28% chromium and 2% nickel. Electrodes are flats with square or rectangular cross section as the opposing surfaces of such electrodes cause better concentration of magnetic flux than a round surface.

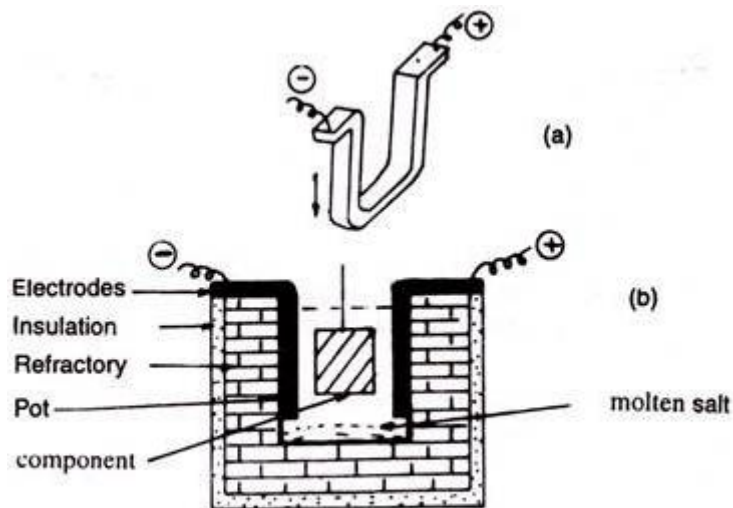

Fig. .7. Immersed electrode salt bath furnace

The electrodes are connected to the secondary of the transformer to power the furnace. As the molten salts have electrical resistance, the heat is generated within the salt bath when the current is passed through the electrodes to the bath. Fig. 8 illustrates one immersed electrode salt bath furnace.

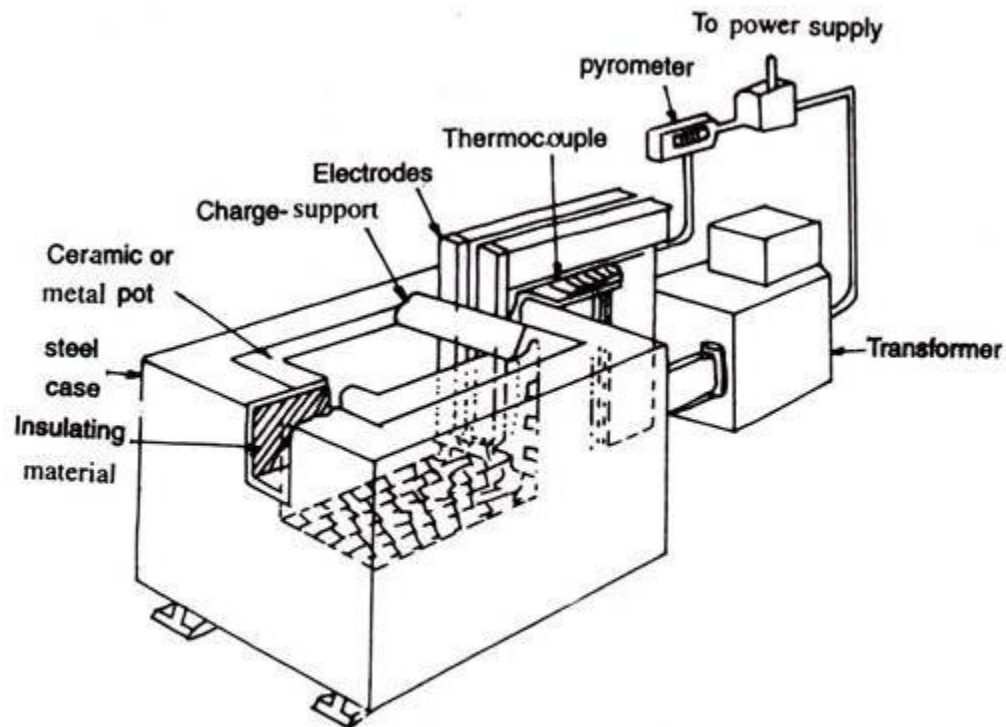

Fig. .8. Immersed electrode and ceramic tile salt bath furnace.



Starting of the Salt Bath Furnace:

Solid salts are bad conductors of electricity, but once the ionic salts become molten, then the ionization produces cations and anions, which move through the molten salts under the influence of applied current to opposite electrodes and thus, conduct electricity. In the salt bath furnaces, the fused salt is at the same time a working medium, i.e., transfers heat to the components, as well as acts as heating element, i.e., the electrical resistance of the molten salt to the flow of current generates heat to heat the salt bath to the required heat treatment temperature and also continue maintaining it at this temperature for the required time. As the cold solid salt does not conduct electricity, the salt has to be melted first by means of an auxiliary device, or a oxy-acetylene blow torch till there is enough molten salt between the electrodes to conduct the electricity between the electrodes and thus generate heat to melt more solid salt added later to fill the heating chamber of the furnace with molten salt.

The auxiliary device normally consists of a 'U-shaped' mild steel frame connected at the both ends with copper connectors (Fig. 10.7 a). For starting a salt bath furnace, a layer of salt is spread at the bottom of the empty furnace, and the U-shaped section is put in the heating chamber of the furnace. It is connected to either a separate power supply or to the provisions made on the electrodes outside the heating chamber.

Some salt is added into the chamber. Now, the power is supplied at low taps of the transformer. The electrical resistance of this mild steel U- section, generates heat and melts the salt. More salt is added and made molten till there is sufficient molten salt in the furnace to make good electric connection between the electrodes through the molten salt, i.e., it itself can act as heat producer.

The 'U-shaped' device is then taken out and then the power is switched on through the electrodes to the molten salt. Before closing down the furnace, and while the salt is still molten, the dry 'U-shaped' device is again placed inside the heating chamber. As the salt solidifies, the device remains inside it, so that starting the furnace for the next heat treatment can be done by it.

Many times, instead of the 'U-shaped' mild steel auxiliary device, a graphite disc is placed on the salt spread on the bottom of the furnace so that the disc presses against the ends of the auxiliary electrodes. The power is switched on with maximum voltage supplied to it. The graphite disc becomes incandescent and thus, melts the salt. More salt is added till that also melts. After a sufficient molten salt has been produced, the auxiliary electrodes and the graphite disc are removed.

Now the temperature of the salt may be raised by the direct application of the current to the molten salt and more salt may be added to the furnace. Increasing the currents

Page 19 of 105	Federal TVET Agency Author/Copyright	TVET program title- Machining Level -2	Version -1 October 2019
----------------	---	--	----------------------------



helps in faster rate of heating of the salt bath to the required heat treatment temperature. The temperature of the bath is automatically controlled with the help of thermocouples, pyrometers, temperature controllers within plus or minus 5°C of the required temperature.

Type # 7. Fluidized-Bed Furnaces:

Fluidized-bed furnaces have become recently quite common in use replacing neutral salt baths, atmosphere furnaces for hardening, annealing, normalising in 750-1050°C range; cyanide salts bath, atmosphere furnaces for surface treatment; salt baths and forced-air circulation furnaces for tempering in range 100-750°C; and even continuous furnaces.

The furnace essentially consists of a porous plate above which is the bed of dry fine particles of sieve size 80 to 100 grits commonly of aluminium oxide for heat treatment of metals, though sand, or zirconium oxide, etc. are also used. The bed is made to act like a liquid (fluid) by a moving gas fed upwards, so that the bed goes into motion and the upper surface of the bed disappears.

This is called the disperse (or lean) phase fluidized bed with pneumatic transport of the solids. Although the disperse phase bed furnaces are used for long and thin parts like shafts and plates, but more commonly, dense phase fluidized bed furnaces are used in which the components to be heat treated are submerged in a bed of fine solid particles held in suspension without any particle entrainment by a flow of the gas.

The bed is fluidized by air, or a mixture of gases, depending on the requirement of the process. For example- for neutral hardening or tempering, nitrogen gas is used; for carburising a mixture of methanal, N₂ and propane, or a mixture of propane and air, is used.

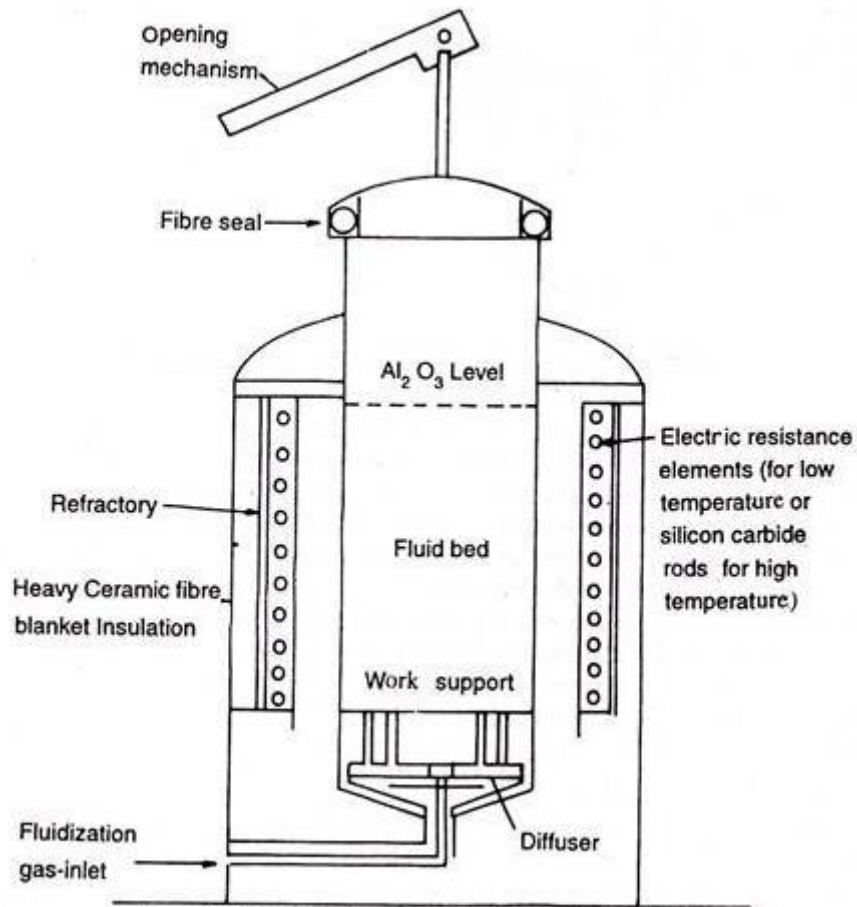

Fig. 9. External heating electrical resistance fluidized-bed furnace.

Fluidized beds have high heat transfer efficiency-around 8 to 25 times of forced air circulation type of furnaces. This is because of turbulent motion and rapid circulation of the particles in the fluidized furnace, and due to the high solid-gas interfacial area. This is attained when the flow rate is two to three times the minimum fluidization velocity. As said, it is possible to obtain various types of atmospheres in fluidized beds such as reducing or oxidising, neutral and carburising. The atmospheres in the fluidized beds could be ammonia, neutral gas, N_2 and air; mixtures of propane and air for carburising to obtain high effective case depth of 1 mm in 1.5 hour. Normally larger volume of propane is consumed in such furnaces.

Commonly used fluidized-bed furnaces are of following types:

1. External Electric-Heating Fluidized Furnace:

The retort containing the fluidized bed is heated from external electrical resistance elements or silicon carbide rods as illustrated in Fig. 9. Here, fluidized gas can be maintained at any desired composition. It takes normally 3-4 hours to heat to the normal heat treatment temperature of 820-870°C.



2. External Gas-Fired Fluidized Furnace:

A burner burns a fuel gas- air mixture to flow around and heat the retort containing the bed. Burners can be controlled well to even get low tempering temperatures.

3. Sub-Merged Combustion Furnace:

In such furnaces, the products of combustion of fuel are passed through the bed and parts, which results in excellent rate of heat transfer.

4. Internal Combustion Gas-Fired Furnace:

Here, the gas-air mixture, for heating and for fluidization, are ignited in the bed, generating heat by internal combustion, i.e., the bed is fluidized by burning gases to generate heat in the bed. If the furnace is controlled properly, it is possible to heat to 800°C in 1 and 1½ hours.

As there is uniform temperature in the fluidized furnaces, and as the fluidized beds have high thermal conductivity, it is possible to quench many parts in fluidized bed that are normally air cooled resulting in least distortion or cracks. Fluidized-bed furnaces are cheaper to install than other furnaces except the salt bath furnaces.

2.4. Necessary tool and equipment

Heat Treating Furnaces and related equipment include the heating devices (furnaces), fixtures and/or holding devices, quenching systems, and atmosphere and temperature control systems all of which are required for the majority of heat treating operations. Carry out heat treatment pre/post preparation processes materials. Needed tools and equipments are as following described.

- **Trays and Grids.** Many parts to be heat treated are irregular in shape and as such must be conveyed through the continuous-heat-treating furnaces or loaded and unloaded from the batch furnaces on grids or tray.
- **Baskets and Fixtures.** In many situations, parts being heat treated are of a size that does not permit them to be loaded directly on a furnace hearth, tray, or grid. They require some type of container, such as a basket.
- **Furnace Atmospheres,** in many heat treating operations, austenitizing must be performed under conditions that provide some form of surface protection for the work pieces. If this is not done, work pieces may become severely oxidized (have severe scale buildup) and/or become decarburized.

Natural Atmospheres (Air). A natural atmosphere is the air we breathe, which is essentially composed of 79% nitrogen and 20% oxygen.

Products of combustion, in direct-fired furnaces automatically provide some atmosphere protection compared with exposure to air. When fuels are mixed with air



and burned at the ideal ratio, a condition results wherein minimal reaction with the steel surfaces occurs.

- **Carry out heat treatment pre/post preparation processes to include the following:**
 - ✓ Cleaning and removing all surface contamination
 - ✓ Applying/removing any required masking/surface protection to areas not requiring heat treatment
 - ✓ Carrying out drying or pre heating requirements
 - ✓ Ensuring that materials/component to be immersed in hot treatment solutions are dry
 - ✓ Carrying out/removing jiggging and hanging of components



Self-Check -2	Written Test
----------------------	---------------------

Directions: Answer all the questions listed below. Use the Answer sheet provided in the next page:

1. Among the listed which one is heating devices for heat treatment processes?
A. Furnaces B. Holding devices C. None of the above
2. _____ and _____ of heat treating furnaces vary over such a wide range that any precise classification is virtually impossible.
A. Sizes B. Designs C. A & B
3. Modes of heat transmission of furnace can be classified
A. Conduction B. Convection C. Radiation D. All
4. From the listed which one is batch-type furnaces
A. Pit furnace B. Boggine (car type) furnace C. Muffle furnace D. All
5. The commonly heating operation tools and equipment used for heating treatment workshop.
A. Heating devices (furnaces)
B. Fixtures and/or holding devices
C. Quenching systems
D. Atmosphere and temperature control
E. All the above
6. Heating sources of fuels used on heat treating workshop.
A. Gas B. Oil C. Electricity. D. All

Note: Satisfactory rating - 3 points

Unsatisfactory - below 3 points



Information Sheet-3	Select equipment to standard operating procedures
----------------------------	--

3.1 Introduction

For heat treatment of steel and alloy steel, the end-user has a wider range of basic types of heat treating equipment to choose from alternatives the criteria that must be considered in selecting equipment for a specific application. To perform heat treatments, which modify the microstructure of the material or change the phase structure to improve the properties for applications for further work processing.

1.2. Selection of heat-treatment furnaces

The requirements of heat-treatment furnaces are as follows:

- **Uniform heating of the work.** This is necessary in order to prevent distortion of the work due to unequal expansion, and also to ensure uniform hardness.
- **Accurate temperature control.** The critical nature of heat-treatment temperatures requires the furnace be capable of operating over a wide range of temperatures, but it must be easily adjustable to the required process temperature.
- **Temperature stability.** It is essential that the temperature is not only accurately adjustable but once set the furnace must remain at the required temperature. This is achieved by ensuring that the mass of the heated furnace lining (refractory) is very much greater than the mass of the work (charge). It can also be achieved by automatic temperature control, or by both.
- **Atmosphere control.** Should the work be heated in the presence of air, the oxygen in the air attacks the surface of the metal to form metal oxides (scale). This not only disfigures the surface of the metal, it can also change the composition of the metal at its surface. For example, in the case of steels, the oxygen can also combine with the carbon at the surface of the metal. Reducing the carbon content results in the metal surface becoming less hard and/or tough. To provide atmosphere control, the air in the furnace is replaced with some form of inert gas which will not react with the work-piece material. Alternatively the work may be heat treated by totally immersing it in hot, molten salts.
- **Economical use of fuels.** It is essential – if heat-treatment costs are to be kept to a minimum – for the furnaces to be run continuously and economically on a shift work basis since the fuel required to keep firing up furnaces from cold is much



greater than that required for continuous running. Thus it is more economical for small workshops to contract their heat treatment out to specialist

- **Firms.** who have sufficient volume of work to keep their furnaces in continuous use.
- **Low maintenance costs.** Furnaces are lined with a heat-resistant material such as firebrick. Since a furnace must be taken out of commission each time this lining is renewed, it should be designed to last as long as possible

Selecting equipment for tool steels heat treating

In making this choice, the most important criterion must be the quality of the tool or part after processing. Like optimum performance, surface finish and sub-surface properties, and shape and distortion.

Optimum performance: - part or tool performance is related to the overall microstructure of the piece and is normally measured in terms of hardness, toughness and fatigue performance. Other properties such as wear resistance and resistance to thermal checking are also important.

Surface finish and sub-surface properties:- where the work piece will not undergo further machining or polishing of criteria working surface after heat treatment, plastic mold tools, its surface quality is equal in important with its microstructure. Sub-surface effects, such as those caused by electrical discharge machining or by carburization and decarburization, are also important and cannot be ignored.

Shape and distortion:- distortion is less a problem to the end-user than to the tool or part maker, who must take preventive action to ensure that the final dimensions will be achieved , or alternatively, to provide sufficient machining allowance after heat treatment so that the required tolerances can be met. As a result, this is an area where conflicts can arise between the tool maker and the end user, because sometimes each has different criteria (e.g. the former requires minimum distortion, while the latter requires maximum performance).

3.3. OHS hazards and suitable PPE

Hazards in heat treatment include burns and scalding, mechanical hazards from steel hardening, and hazards arising from the annealing gases, including nitrogen, hydrogen and carbon monoxide. Furnace insulation wools can expose workers to hazardous fibres.

Personal protective equipment should be selection considering of the proper equipment, in assuring that it is correctly fitted to the people who use it, in the nature of the hazards the equipment is intended to protect against, and provide



adequate comfort, and in the consequence of poor performance or equipment failures

3.4. Necessary tools and equipments

Commonly Used Equipment for Heat Treating Operations

- Metal Cleaning (Wash-Rinse) equipment
- Gas fired furnaces
 - ✓ Direct fired using burners fired directly in to a furnace
 - ✓ Indirect fired furnaces: radiant tube, muffle, retort, etc.
 - ✓ Molten salt (or lead) bath
 - ✓ Fluidized bed
- Electrically heated furnaces
 - ✓ Induction heating
 - ✓ Electrical resistance heating
 - ✓ Other (i.e. Laser, electron-beam, etc).
- Quench or cooling equipment
- Material handling system
- Testing and quality control laboratory equipment

The considerable things selecting equipment for tool steels heat treating

The choice of heat treating equipment varies with application. Selecting the right style and Type of equipment will ensure the highest quality products.

Equipment selection

The metallurgical criteria must be satisfied when considering which technique or equipment is to be used for the heating treatment cycle. In assessing equipment the following factors are generally compared:- Temperature range and uniformity

- Heating and cooling rate
- Atmosphere integrity

These factors rank highest because they most directly affect the major criteria of quality control and reproducibility. If the equipment meets these requirements, then the other considerations to be weighed are – Environmental considerations

- Capital and operating costs
- Ease of operation and maintenance



Self-Check -3	Written Test
----------------------	---------------------

Directions: Answer all the questions listed below. Use the Answer sheet provided in the next page:

1. To obtain appropriate properties of heat treated components to satisfied the end-user things that must be considered is
 - A. Selecting appropriate equipment for operation
 - B. Working by the available equipment

2. In order to make choice the most important criterion must be consider after processing of quality of the tool steel or part.
 - A. optimum performance
 - B. surface finish and sub-surface properties
 - C. Shape and distortion.
 - D. All the above

3. To produced in assessing equipment the following factors are generally compared on tool steels.
 - A. Temperature range and uniformity
 - B. Heating and cooling rate
 - C. Atmosphere integrity
 - D. All the above

Note: Satisfactory rating - 5 points

Unsatisfactory - below 5 points

Answer Sheet

Name: _____

Date: _____

Score = _____
Rating: _____



Information Sheet-4	Use Personal protective equipment/devices
----------------------------	--

4.1. Introduction

Safety in heat treatment

Heat treatment can involve large pieces of metal at high temperatures and powerful furnaces. Therefore, it is necessary to consider some safety practices relating specifically to heat treatment processes, before discussing the processes involved.

4.2. Personal protective equipment / devices

- 1. Overalls** used in heat treatment shops should be made from a flame resistant or a flame retardant material and be labeled accordingly. In addition, a leather apron should be worn to prevent your overalls coming into contact with hot work-pieces and hot equipment.
- 2. Gloves** should be worn to protect your hands. These should be made from leather or other heat resistant materials and should have gauntlets to protect your wrists and the ends of the sleeves of your overalls. Leather gloves offer protection up to 350°C.
- 3. Headwear, Wear a face shield, safety goggles and visors** should be worn
- 4. The safety shoes and boots** as recommended for wearing in workshops .They are also the most suitable for use in heat treatment shops. In addition, it is advisable that leather spats are worn.



Self-Check -4	Written Test
----------------------	---------------------

Directions: Answer all the questions listed below. Use the Answer sheet provided in the next page:

1. On heat treating operation can involve larger pieces of metal work done at
A. high temperatures B. powerful furnace
2. Before any operation at heat treating operation necessary to give attention on consider
A. Applying safety practices B. Prevent accident
3. From the listed which one of the following is not personal protective equipment / devices.
A. Headwear
B. Wear a face shield
C. Safety shoes and boots
D. Gloves
E. None of the above

Note: Satisfactory rating - 5 points

Unsatisfactory - below 5 points



Instruction Sheet

Learning Guide #36

This learning guide is developed to provide you the necessary information regarding the following **content coverage** and topics –

- Identifying Hazards and implement control measures
- Perform furnace start-up
- Apply and maintain required heating temperature, soaking time and cooling time
- Heat treating materials as required

This guide will also assist you to attain the learning outcome stated in the cover page. Specifically, upon completion of this Learning Guide, **you will be able to –**

- Identify hazards and implement control measures to maintain a safe work environment.
- Perform furnace start-up as per standard operating procedures and safety requirements.
- Apply and maintain required heating temperature, soaking time and cooling time according to standard operating procedure.
- Heat treating materials to achieve required result in accordance with standard operating procedures and customer requirements

Learning Instructions:

1. Read the specific objectives of this Learning Guide.
2. Follow the instructions described below.
3. Read the information written in the “Information Sheets”. Try to understand what are being discussed. Ask your trainer for assistance if you have hard time understanding them.
4. Accomplish the “Self-checks” which are placed following all information sheets.
5. Ask from your trainer the key to correction (key answers) or you can request your trainer to correct your work. (You are to get the key answer only after you finished answering the Self-checks).
6. If you earned a satisfactory evaluation proceed to “Operation sheets
7. Perform “the Learning activity performance test” which is placed following “Operation sheets” ,
8. If your performance is satisfactory proceed to the next learning guide,
9. If your performance is unsatisfactory, see your trainer for further instructions or go back to “Operation sheets”.



Information Sheet-1	Identifying Hazards and implement control measures
----------------------------	---

2.1. Introduction

Any practice that causes a furnace chamber (heated or unheated); to lose positive pressure while running a combustible atmosphere is a major cause for concern and a possible call for immediate action. Examples include power failures, air leaks, loss of the heating system, carrier-gas settings lower than normal, unexpected door openings and loss of furnace temperature. These types of conditions can lead to the uncontrolled infiltration of air into furnace chambers, which could rapidly lead to an unsafe condition – faster in many instances than operators might be able to respond.

Transfer of loads in integral-quench furnaces to the quench-tank area and normal burn-in and burnout of furnace atmosphere are conditions that routinely create loss of positive-pressure conditions. Following manufacturer's instructions and company practices will ensure these situations remain under control despite loss of positive pressure. Other conditions, such as furnace pressure loss during transfers between chambers, should be monitored and the burnoff flame recovery observed (and timed) to understand how quickly the furnace positive pressure has been reestablished under these conditions.

Processes are often run, either intentionally or unintentionally, below 760°C (1400°F). Process examples include loss of temperature inside a furnace chamber when a large cold load is introduced, nitrocarburizing at 580°C (1075°F) or stress-relief annealing at 730°C (1350°F) that are run below the industry-recognized auto-ignition temperature. In these cases, good practices and certain precautions are necessary. For example, outer doors should never be opened under low-flow conditions or without properly functioning pilots and flame curtains. Another especially critical time in the cycle is during load transfer or introduction of a load into the furnace while another is quenching.

Safety

Prevention of industrial accidents involving unwanted fires and gas explosions not only requires knowledge of the flammability characteristics (e.g., limits of flammability, ignition requirements, burning rates) of the combustible gases and vapors likely to be encountered under various conditions of use (and misuse) in the heat-treat shop, but also an understanding of the internal and external conditions that may be present when operating a particular piece of equipment or that exist in the environment surrounding that equipment.

Page 32 of 105	Federal TVET Agency Author/Copyright	TVET program title- Machining Level -2	Version -1 October 2019
----------------	---	--	----------------------------



Safety notices or tags

Whilst metal is red hot it is obviously in a dangerous condition. However, most accidents occur when the metal has cooled down to just below red heat. Although no longer glowing, it is still hot enough to cause serious burns and to start fires if flammable substances come into contact with it. Hot work-pieces must never be stored in gangways and warning notices must be used. Such notices must satisfy the legal requirements of the Health and Safety Executive.

Fire

Quenching baths using a quenching-oil must have an airtight lid. In the event of the oil overheating and igniting, the lid can be closed which puts the fire out. Quenching tanks should always have sufficient reserve capacity so that the oil does not overheat. If the oil is allowed to overheat, it: Will not cool the work quickly enough to harden it and May catch fire. Only quenching-oil, with a high flash point and freedom from fuming, should be used. Lubricating oil must never be used.

A suitable fire extinguisher, or several fire extinguishers if a large quenching tank is used, should be positioned conveniently near to the bath in case of an emergency. Furnaces and blowpipes must not be lit or closed down without proper instruction and permission. Incorrect setting of the controls and incorrect lighting up procedures can lead to serious explosions. All personnel working in heat treatment shops must be alert to the possibility of fires, and be conversant with, and trained in, the correct fire drill.

What should you know before participate in heat-treating operations?

- During heat-treating operations, the metal is subjected to heating or cooling to acquire specific properties from that metal.
- Heat-treating operations require a quench as an integral part of this process. Liquid quenches normally involve the use of mineral oils, water-based solutions or molten salt. Less severe quenches use circulated gases or forced air, or involve cooling in still air.
- Quenching operations pose various health and safety hazards to workers. These include exposure to chemicals, working in high temperatures, and the risk of fire or explosion.
- Consider the properties of the quenchants plus the design, construction, location, control, monitoring and maintenance of the furnace itself to minimize these risks.
- Quenching operations are often followed by a degreasing with chlorinated solvents or water-soluble compounds.
- Only operate heat-treating equipment when properly trained.



- the safe working practices and procedures to be observed when working with hand and power surface preparation tools (such as general workshop and site safety, protecting other workers from the effects of the work, environmental controls)
- the health and safety requirements of the work area in which you are carrying out your heat treatment material surface preparation activities, and the responsibility they place upon you
- The hazards associated with carrying out heat treatment material pre/post surface preparation activities, and with the materials and equipment used, and how they can be minimized.
- The personal protective equipment (PPE) to be worn during the heat treatment material surface preparation activity, and its care and correct use
- How to obtain the required work procedures, specifications and instructions, and how to interpret their requirements.
- The reasons for carrying out heat treatment material surface preparation, and the effects on the heat treatment activities if preparations are not carried out correctly.
- The damage that may result from using inappropriate tools and techniques.
- Why different types of substrate require different preparation techniques to be used.
- The types of defects and contamination to be found on materials/components to be heat treated.
- Types of tools and equipment used for the surface preparation activities (to include setting up and safe operation, manufacturers' operating instructions, and techniques for using them).
- Why some surfaces may require masking/protection from the heat treatment process and the type of masking materials and mediums that are used.
- Methods of jiggging and wiring/holding components for the heat treatment process.
- Quality control techniques and procedures used during the heat treatment material preparation activities.
- How to dispose of waste materials safely, including the environmental impact of the materials you are using, and the minimization of this impact

What are some safety precautions to follow during a heat-treating operation?

- ✚ Wear a face shield, safety glasses, gloves and heat-resistant protective clothing when working with hot metal. Quench oils may be very hot (above 100°C) and oil temperature increases during quenching. Splashes or skin contact cause burns. Avoid skin contact with oils by using gloves and protective clothing.
- Check that all safety devices, such as automatic shut-off valves, air switches, and exhaust fans are working properly before lighting the furnace.



- Ensure the volume of the cooling medium is sufficient for the job. As the metal cools, the medium absorbs the heat. If there is not enough medium, it will become too hot to cool the metal at the desired rate.
- Ensure that quenching areas have enough ventilation to keep oil mists at recommended levels.
- Follow the manufacturer's instructions when lighting the furnace.
- Stand to one side when lighting a gas- or oil-fired furnace.
- Ensure that water does not contaminate the quenching oil. Any moisture which comes in contact with the oil can cause an explosion.
- Use the proper tongs for the job and make sure the tongs are dry before removing any work from a liquid carburizing pot.
- Ensure that a suitable bacterial inhibitor or fungicide has been added to the quenching liquid.
- Cover quenches tanks when not in use.
- Clean up oil spills and leaks immediately using a nonflammable absorbant.
- Keep work areas, jigs, baskets and tools free from oil contamination where possible.
- Wash hands thoroughly after work, at breaks (particularly meal times), before starting other tasks, or before using the toilet.
- Obtain first aid for all cuts and abrasions. Protect them from contamination by using suitable dressings.
- Report to your supervisor and obtain medical attention when suffering from, or suspecting, skin trouble.
- Free access to this area is restricted to authorized personnel only. No other person may enter the heat treatment room without permission.
- No welding may be undertaken unless the technician-in-charge is satisfied that the person is capable of doing so safely.
- Any person working in the heat treatment room must have read and signed the appropriate risk assessment if the work or equipment they are using has been risk assessed. Risk assessments are kept in the filing cabinet within the mechanical workshop.



Effects of furnace on the working area lead to hazards

The furnace atmosphere itself affects the condition of the metal being heat treated. This atmosphere consists of the gases in the furnace's heating chamber that circulate and surround the metal being heated.

In an electric furnace, the atmosphere is either air or a controlled mixture of gases.

In a fuel-fired furnace, the atmosphere is a mixture of gases and air. Air combines with gases released by the fuel's combustion resulting in various proportions of carbon monoxide (CO), carbon dioxide (CO_2), hydrogen (H), nitrogen (N), oxygen (O), water vapor (H_2O), and other various hydrocarbons (C_nH_{2n}). When you vary the proportions of air and fuel in a fuel-fired furnace, you can provide three distinct atmospheres: oxidizing, reducing, and neutral.

Activate Win

Page 36 of 105	Federal TVET Agency Author/Copyright	TVET program title- Machining Level -2	Version -1
			October 2019



Self-Check -1	Written Test
----------------------	---------------------

Directions: Answer all the questions listed below. Use the Answer sheet provided in the next page:

1. Which one of the following is the common accident occurring on heat treating process times?
A. Serious burns B. risk of fire or exposed C. Carbon monoxide D. All
2. Among the following which one is not hazard and implements control measures.
A. Using Safety notices or tags
B. Using safety precautions
C. Using suitable fire extinguisher
D. Using OHS and PPE as occupational requirements
E. None of the above given
3. From the listed which one of the following is not
A. Cover quenches tanks when not in use.
B. Ensure that water does not contaminate the quenching oil
C. Follow the manufacturer's instructions when lighting the furnace
D. Clean up oil spills and leaks immediately using a nonflammable absorbant.
E. None of the above

Note: Satisfactory rating - 5 points

Unsatisfactory - below 5 points

Answer Sheet

Score = _____
Rating: _____

Name: _____

Date: _____



Information Sheet-2	Perform furnace start-up
----------------------------	---------------------------------

2.1. Introduction

Heat treatment is an important manufacturing process. Furnace is key element in the heat treatment process, but different types in method of operation, types of heating, material system, and types of energy used. This all types of heat treating operator has to familiar in order to develop his/ her knowledge's and skills towards performing furnace start-up, pre/ post cleaning material and loading/ unloading material from the furnace by controlling the temperature.

As a manufacturer of electrically and gas heated furnaces for heat treatment, Nabertherm offers a wide range of accessory equipment and consumable materials required for heat treatment.

Industrial heating and heat treating furnaces are heated by gaseous or liquid fuels, or by electric heating elements. Natural gas is the principal gaseous fuel used in the United States. It has a gross heating value of about 37 MJ/m³ (1000 Btu/ft³). For combustion, natural gas requires about 0.28 m³ (10 ft³) of air per cubic foot of gas. Other fuels of this type include liquefied petroleum gases such as propane and butane. The heat treater often has choices for burners and combustion systems when purchasing new equipment or rebuilding older furnaces and ovens. While natural gas prices are highly competitive today, a key consideration is to match the heating and temperature uniformity needs of the applications with the best and most cost-effective systems.

2.2. Carry out pre/post heat treatment material preparation activities on all of the following types of material/components:

Furnace Loading

Furnace loading is a key heat treatment parameter influencing the time-temperature profiles of furnace loads during heat-up to the austenitizing temperature. Loading must consider the weight of the furnace load, as well as the load density. Furnace loading varies considerably among foundries and also varies significantly from heat treatment to heat treatment at a given foundry. Many foundries carefully plan their furnace loading to provide 'adequate circulation' of furnace gases through the load for consistent austenitization. However, furnace loading practices in steel foundries are very furnace and casting load dependent. Baskets full of small castings might give the same overall furnace load density as a whole furnace filled with fewer larger castings, but the castings at the center of the basket will be somewhat insulated and will take longer to reach the proper temperature. Thus local load density as well as overall furnace load density must be considered.



2.3. Effects of furnace on heating

Furnace Treatments, The goal of any furnace hardening treatment of finished parts is to maintain the surface and base carbon condition. Depending on the furnace atmosphere conditions and the surface condition of the work piece, the heat treatment can either maintain the same carbon as the work piece, restore the surface carbon, or cause decarburization. See “Instrumentation and Control of Heat Treating Processes,” for information about the control devices necessary to maintain the proper surface carbon conditions in furnace atmospheres.

Induction Hardening, because induction hardening involves heating to above the critical temperature in air, the treatment can be a source of decarburization. For a typical 5 s heat cycle to 950C (1750F), the decarburization depth is calculated to be 0.00197 cm (0.00078 in.). This depth is so shallow that decarburization caused during induction heat treating generally is not a problem. The more common problem is decarburization that has not been removed prior to the induction hardening process.

Fluidized bed processing, the depth of decarburization of cold worked steel in a fluidized, bed at various temperatures.

The furnace atmosphere itself affects the condition of the metal being heat treated. This atmosphere consists of the gases in the furnace’s heating chamber that circulate and surround the metal being heated.

In an electric furnace, the atmosphere is either air or a controlled mixture of gases.

In a fuel-fired furnace, the atmosphere is a mixture of gases and air. Air combines with gases released by the fuel’s combustion resulting in various proportions of carbon monoxide (CO), carbon dioxide (CO_2), hydrogen (H), nitrogen (N), oxygen (O), water vapor (H_2O), and other various hydrocarbons (C_nH_{2n}). When you vary the proportions of air and fuel in a fuel-fired furnace, you can provide three distinct atmospheres: oxidizing, reducing, and neutral.

Activate Win

2.4. OHS hazards and suitable PPE

OHS hazards

Hot work-pieces must never be stored in gangways and warning notices must be used. Such notices must satisfy the legal requirements of the Health and Safety Executive.

Personal protective equipment / devices

Overalls used in heat treatment shops should be made from a flame resistant or a flame retardant material and be labeled accordingly. In addition, a leather apron should be worn to prevent your overalls coming into contact with hot work-pieces and hot equipment.

Page 39 of 105	Federal TVET Agency Author/Copyright	TVET program title- Machining Level -2	Version -1 October 2019
----------------	---	--	----------------------------



Gloves should be worn to protect your hands. These should be made from leather or other heat resistant materials and should have gauntlets to protect your wrists and the ends of the sleeves of your overalls. Leather gloves offer protection up to 350°C.

Headwear, Wear a face shield, safety goggles and visors should be worn

The safety shoes and boots should be worn.

2.5. Necessary tools and equipments

Heat treating operations generally consist of three separate functions: **material movement**, the application of energy, and the supervision of process conditions.

In a typical heat treating operation, work is moved into a furnace, heated according to a time-temperature program while exposed to defined surrounding conditions; cooled or quenched under certain conditions; and, finally, moved out of the quench vessel or furnace. The temperature, and frequently the atmosphere condition, must be controlled precisely in order to achieve the desired metallurgical results. In order to ensure the repeatability of the operation, the heat treating system must have the necessary sensors, timers, and variable (temperature, atmosphere, etc.) controllers to hold the process within prescribed or specified limits.

Temperature-Control Systems

In any temperature-control system, three steps must be executed. Before control can be established, the variable must first be “sensed” by some device that responds to changes in the quality or value of the variable. This quantity, or its change, must then be indicated or recorded prior to being controlled. The last step in the sequence is the transmission of the controller output to the “final element,” which is a component of the process itself. Final elements relay the output of the controller and cause corrective changes in the process.

Temperature Sensors

As is often the case, one variable is measured then translated, or converted, to another. For example, ambient temperatures actually are measured by expansion or contraction of a column of fluid or of a metal (e.g., mercury). By means of calibration, these variables are converted to numerical temperature readings. These simple devices, however, are not suitable for the higher temperatures involved in most heat treating operations. The temperature sensors used in heat treating can be divided into contact and the noncontact types.

Resistance temperature detectors (RTDs) are contact-type sensors. Their electrical resistance is proportional to temperature. Typical detector materials are platinum, copper, and nickel. Resistance temperature detectors are normally larger in size and slower in response than thermocouples.

Page 40 of 105	Federal TVET Agency Author/Copyright	TVET program title- Machining Level -2	Version -1 October 2019
----------------	---	--	----------------------------

Thermocouples are the most widely used contact sensors for measuring temperatures of heat treating processes. In this instance, however, the same approach is used; that is, one variable is measured then converted to another.

To obtain accurate temperature sensing, thermocouples must be placed near the work. In many instances, more than one thermocouple may be used within a given furnace. Thermocouple elements with ceramic insulation inside a protection tube are available (Fig. 1).

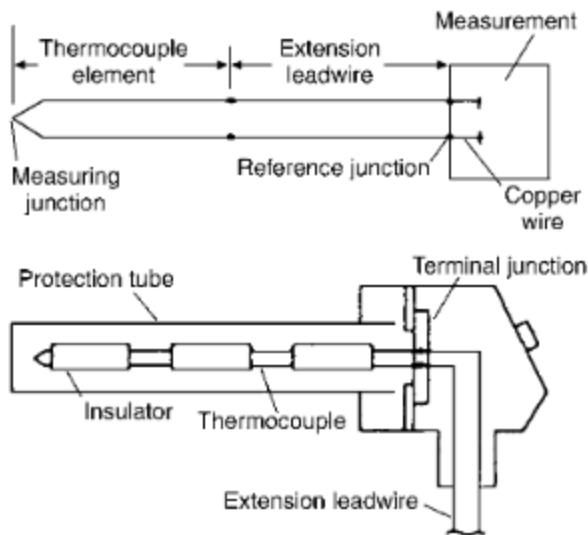

1 Simple thermocouple (upper view) and cutaway of a thermocouple assembly (lower view). Source: Ref 1

Temperature measurement represents the second step in a temperature-control system. Measurement instruments measure the output signal (millivolts) of the temperature sensor and convert it to a temperature indication. Measurement instruments may also have the capability of controlling and/or recording the temperature. The indicating phase of the system must, however, be calibrated and set for the two dissimilar metals used in the thermocouple. The accuracy of the measurement depends primarily on the accuracy of the temperature sensor and the connecting lead wire (Table 1). The accuracy of the digital measurement instrument generally is 0.01% of the full scale reading.



Table 1 Thermocouple types, nominal temperature ranges, and material combinations

Type	Nominal temperature range		Typical thermocouple material(a)
	°C	°F	
B	50–1818	120–3300	PLATINUM, 30% RHODIUM-platinum, 6% rhodium
E	0–870	32–1600	CHROMEL-constantan
J	–185 to 760	–300 to 1400	IRON-constantan
K	0–1260	32–2300	NICKEL, CHROMIUM-nickel, aluminum, CHROMEL-alumel
R	0–1480	32–2700	PLATINUM, 13% RHODIUM-platinum
S	0–1480	32–2700	PLATINUM, 10% RHODIUM-platinum
T	–185 to 370	–300 to 700	COPPER-constantan
W5	–20 to 2205	0–4000	TUNGSTEN, 5% RHENIUM-tungsten, 26% rhenium

(a) Uppercase letters indicate the positive lead. Source: Ref 2

Temperature control is the third major phase of a temperature-control system. A temperature controller must provide sufficient energy to satisfy process requirements, even though operating conditions vary. Variations include changes in process load, fuel characteristics, and ambient temperature. Thus, controller requirements are more stringent when process requirements are demanding and especially when operating conditions vary significantly.

Non contact Temperature Instruments. Temperature is a measure of the ability to transfer heat. Heat may be transferred by conduction, convection (actually conduction to a fluid followed by translation), and by thermal radiation. Noncontact temperature sensors depend on the thermally generated electromagnetic radiation from a surface of a test object. Electromagnetic radiation is emitted from a heated body when electrons within the body change to a lower energy state. Both the intensity and the wavelength of the radiation depend on the temperature of the surface atoms or molecules. Radiation pyrometers such as the one shown in Fig.3



Fig. 1 Ramp-soak, programmable, single-point temperature controller. Courtesy of Honeywell, Inc.

Atmosphere Control

The purpose of atmosphere control is to maintain consistent levels of the various atmosphere constituents and to determine whether changes in those levels are required in order to produce a desired result under a given set of conditions. Controls are required for various heat treating operations that use a variety of different atmospheres. All methods of atmosphere control can effectively be divided into two groups: those involving control of the atmosphere once it is inside the furnace and those involving control of the atmosphere supply before it is introduced into the furnace. Such control is achieved through the use of atmosphere control devices. For success in metallurgical atmosphere control, gas analysis instrumentation must be applied to the furnace and at the gas generator, if one is used. This is true for endothermic as well as exothermic atmosphere applications.



Fig. 2 An optical pyrometer. Courtesy of The Pyrometer Instrument Company

ATMOSPHERE SENSORS AND CONTROL SYSTEMS

The most common sensors available for the wide variety of furnace atmospheres used can be categorized into three major types: oxygen probe, dew point, and infrared.

These sensors can effectively be used to control endothermic, exothermic, nitrogen-methanol, nitrogen-hydrocarbon, and nitrogen-hydrogen-type atmospheres.

The oxygen probe is based in theory on a hot ceramic electrochemical cell. The probe will respond to oxygen, hydrogen, carbon monoxide, water, and carbon dioxide and thus can determine the oxidization potential of a gas.

Oxygen probe systems are used extensively for control of furnaces used for hardening, carburizing, and carbonitriding. A single-point programmable controller such as is shown in Fig 3.

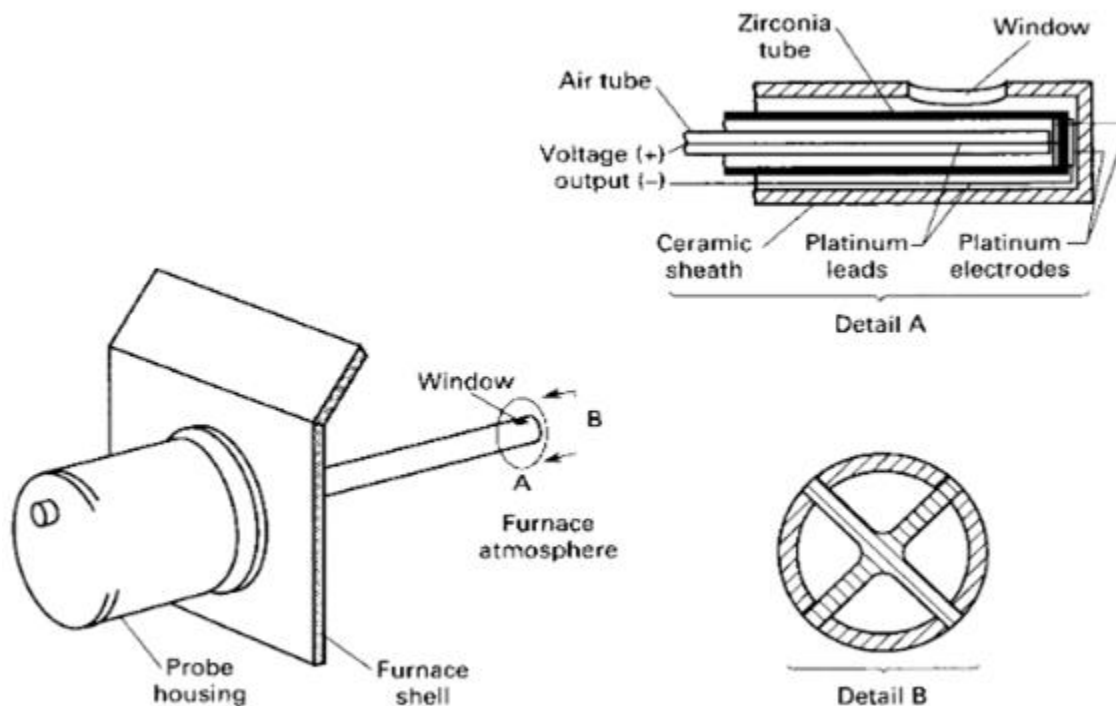

Fig. 3 Components of a typical oxygen probe for controlling carburizing atmospheres. Detail B shows construction of X-cap tip. Source: Ref 3

Dew Point Instrument. Use of a dew point measuring device is another method of monitoring or controlling the carbon potential of a furnace atmosphere. It can also be used to determine the moisture content of any given atmosphere. The sensor consists of an aluminum-base material with an aluminum oxide etched on its surface.



Fig. 4 Programmable digital carbon controller. Courtesy of Honeywell, Inc.

Infrared analyzers are based on the principle that any compound present in the furnace atmosphere mixture will absorb infrared energy in proportion to its weight in the mixture. The wavelengths absorbed are different for each compound. Elemental gases such as hydrogen and oxygen do not absorb infrared radiation and therefore cannot be measured by this method. Infrared analyzers are normally used to measure carbon monoxide, carbon dioxide, and methane.

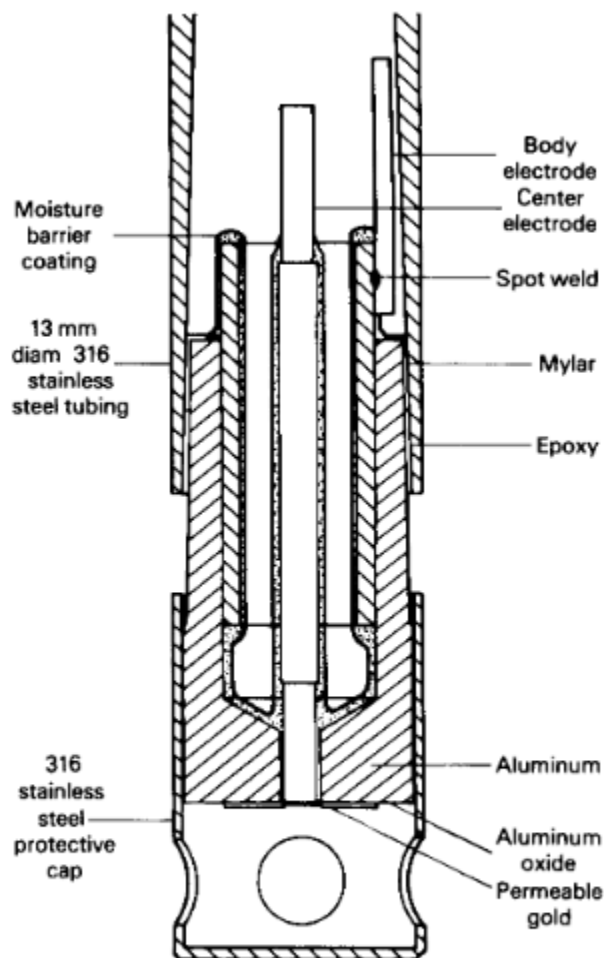

Fig. 5 The aluminum oxide sensor, a type of dew point instrument, measures water content of an atmosphere by change in capacitance between two electrodes. Source: Ref 5

Infrared analyzers are based on the principle that any compound present in the furnace atmosphere mixture will absorb infrared energy in proportion to its weight in the mixture. The wavelengths absorbed are different for each compound. Elemental gases such as hydrogen and oxygen do not absorb infrared radiation and therefore cannot be measured by this method. Infrared analyzers are normally used to measure carbon monoxide, carbon dioxide, and methane.

Integrated Control Systems

Until the mid-1980s, most heat treating equipment relied on relays, timers, manually operated push buttons, and dedicated process control instruments for the control and the sequencing of heat treating equipment operations. This meant that the equipment operator was usually very heavily involved in ensuring that several aspects of the

process were followed. While these furnaces may have produced consistent loads of product with a reasonable reliability, the level of operator attention and skill required often affected the final results.

The development of the programmable logic controller (PLC) offered a solution to these problems. The PLC was originally designed to replace relays, timers, and other hardwired logic control systems and to basically simplify the management of several individual control instruments. Programmable logic controllers are often used to retrofit and update older heat treating equipment.

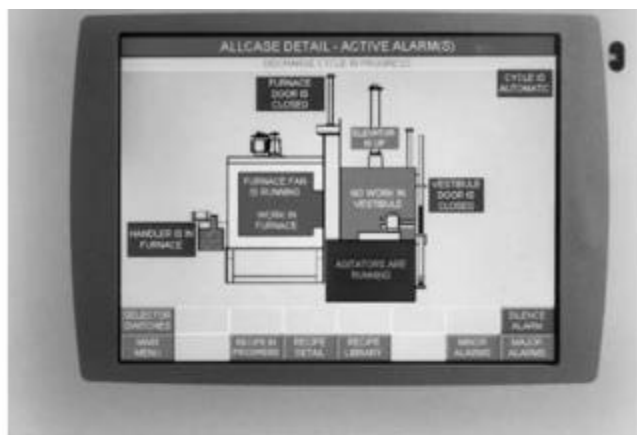

(a)

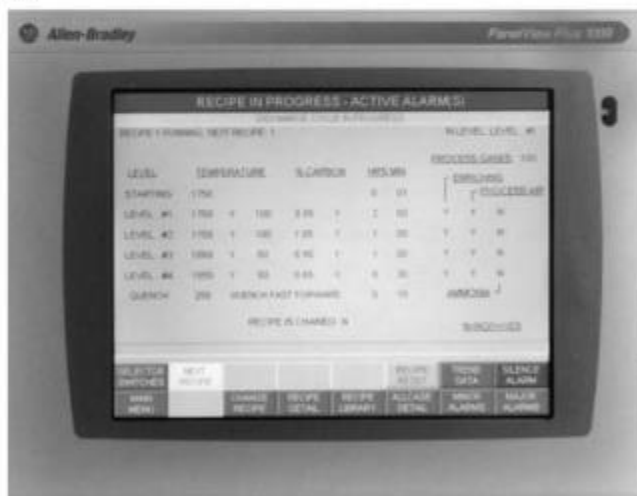

(b)

Fig. 5 Batch atmosphere furnace programmable logic controller (PLC) control system. (a) Furnace function status screen. (b) Furnace recipe control screen. *Courtesy of Surface Combustion Inc.*



Self-Check -2	Written Test
----------------------	---------------------

Directions: Answer all the questions listed below. Use the Answer sheet provided in the next page

1. _____ is key element in the heat treatment process.
A. Furnace B. Material movement C. A & B
2. _____ are the most widely used contact sensors for measuring temperatures of heat treating processes.
A. Thermocouples B. Temperature Sensors C. Temperature measurement
3. Noncontact temperature sensors depend on the _____ from a surface of a test object.
A. thermally generated electromagnetic radiation
B. Atmosphere control
4. The most common sensors available for the wide variety of furnace atmospheres use major types.
A. Oxygen probe B. Dew point C. Infrared D. All

Note: Satisfactory rating - 5 points

Unsatisfactory - below 5 points

Answer Sheet

Score = _____
Rating: _____

Name: _____

Date: _____



Information Sheet-3	Apply and maintain required heating temperature, soaking time and cooling time
----------------------------	---

3.1. Introduction

To successfully heat treat a metal, you need to have the proper equipment with close control over all factors relevant to the heating and cooling. For example, the furnace must be the proper size and type with temperatures controlled and kept within the prescribed limits for each operation, and you must have the appropriate quenching media to cool the metal correct rate.

The furnace atmosphere consists of the gases that circulate throughout the heating chamber and surround the metal, as it is being heated. In an electric furnace, the atmosphere is either air or a controlled mixture of gases. In a fuel-fired furnace, the atmosphere is the mixture of gases that comes from the combination of the air and the gases released by the fuel during combustion. These gases contain various proportions of carbon monoxide, carbon dioxide, hydrogen, nitrogen, oxygen, water vapor, and other various hydrocarbons. Fuel-fired furnaces can provide three distinct atmospheres when you vary the proportions of air and fuel. They are called oxidizing, reducing, and neutral.

3.2. Heat treating stages / cycle

You can accomplish heat treatment in three major stages:

- Stage 1 – Heat the metal slowly to ensure a uniform temperature.
- Stage 2 – Soaking (hold) the metal at a given temperature for a given time.
- Stage 3 – Cooling (Rapid or at slow / controlled rate) the metal to room temperature.

Heating Stage

In the heating stage, the primary objective is to heat uniform, and you attain and maintain uniform temperatures by slow heating. If you heat unevenly, one section can expand faster than another, resulting in a distorted or factors.

The appropriate heating rate will depend on several factors.

- The metal's heat conductivity. A metal with a high-heat conductivity heats at a faster rate than one with one with a low conductivity.
- The metal's condition. The heating rate for hardened (stressed) tools and parts should be slower than the heating rate for unstressed or untreated metals.
- A metal part's size and cross section. To prevent warping or cracking , you need to heat large close to the surface temperature. Parts with uneven cross sections



will naturally tend heat unevenly, but they are less apt to crack or excessively warp when you keep the heating rate slow.

Soaking stage

In the soaking stage, the objective is to hold the metal to the proper temperature until the desired internal structural changes take place. “Soaking period” is the term you use for the time the metal is held at the proper temperature. The chemical analysis of the metal and the mass of the part will determine the appropriate soaking period.

(Note: For steel parts with uneven cross sections, the largest section determines the soaking period.) Expected for the rare variance, you should not bring the temperature of a metal directly for room temperature to soaking temperature in one operation. Instead, heat the metal slowly to temperature just below the point at which the internal change occurs and hold it at that temperature until you have equalized the heat throughout.

Following this process (called “preheating”), quickly heat the metal to its final required temperature. When a part has an intricate design, you may have to preheat it to more than one temperature stage to prevent cracking and excessive warping. For example, assume an intricate part needs to heat to 1500°F for hardening.

You may need to heat this part slowly to a 600°F stage and soaking it at this temperature for a defined period, then heat it slowly and soaking it at a 1200°F stages, and then heat it quickly to the hardening temperature of 1500°F.

Cooling Stage

In the cooling stage, the objective is self-explanatory, but there are different processes to return a metal to room temperature, depending on the types of metal. To cool the metal and attain the desired properties, you may need to place it in direct contact with a **cooling medium** (a gas, liquid, solid, or a combination), and any cooling rate will depend on the metal itself and the chosen medium. Therefore, the choice of a cooling medium has an important influence on the properties desired. Cooling metal rapidly in air, oil, water, brine, or some other medium is **quenching**. Quenching is usually associated with hardening since most metals that are hardened are cooled rapidly during the process. However, neither quenching nor rapid cooling always results in increased hardness. For example, a water quench is usually used to anneal copper, and some other metals are cooled at relatively slow rate for hardening, such as air-hardened steels.

Some metals crack or warp during quenching, while others suffer no ill effects: so the quenching medium must fit the metal. Use brine or water for metals that require a rapid cooling rate: use oil mixtures for metals need a slower cooling rate. Generally, you should water-harden carbon steels, oil-harden alloy steels, and quench nonferrous metals in water.



3.3. Purpose of heat treatment

The purpose of heat treating is to make a metal more useful by changing or restoring its mechanical properties. There are innumerable purposes, which are achieved by heat treatment yet the following are important:-

- To relieving internal stresses, which are set up in metal due to cold or hot working
- To soften the metal.
- To improve hardness of metal surface.
- To improve machinability.
- To refine grain size structure
- To improve mechanical properties like, tensile strength, ductility and shock resistance, etc.
- To improve electrical and magnetic properties.
- To increase the resistance to wear, tear, heat and corrosion, etc.

The Influence of Loading

Of all the variables affecting heating, loading is the one most often taken for granted. Non-uniformity of results, even from the same heat of steel, can be introduced if different parts of the workload are unequally exposed to heat (or cooling). Hence, it is not merely time and temperature but a time-temperature-mass-surface relationship that must be factored into the heating time.

Component parts come in all shapes and sizes. To meet this demand, standard and custom furnaces have been designed to accommodate the many workload configurations. Loading arrangements fall into two general classes: weight-limited and volume-limited. In either case, when loading parts in furnace baskets or onto racks, the goal is often to maximize loading efficiency. As heat treaters, however, we must also be concerned with proper part spacing (i.e. how parts are situated within the load for optimal heat transfer, atmosphere circulation, temperature uniformity and heat extraction during quenching so as to minimize dimensional variation).

How parts are loaded is very much a function of the style of furnace being used. Final spacing is dictated by concerns for heating, soaking, atmosphere flow, the volume and type of quench media (brine, water, polymer, oil, salt, air), and gross load weight. A number of “rules of thumb” used in the industry can help, but determining the proper spacing around parts is critical and is often best done by trial and error.

Recognizing heat colors for steel

“Red-hot” is a term you are probably familiar with as applies to steel, but steel actually takes on several colors and shades from the it turns a dull red unit it reaches a white heat. Figure shows approximate colors and their corresponding temperatures.

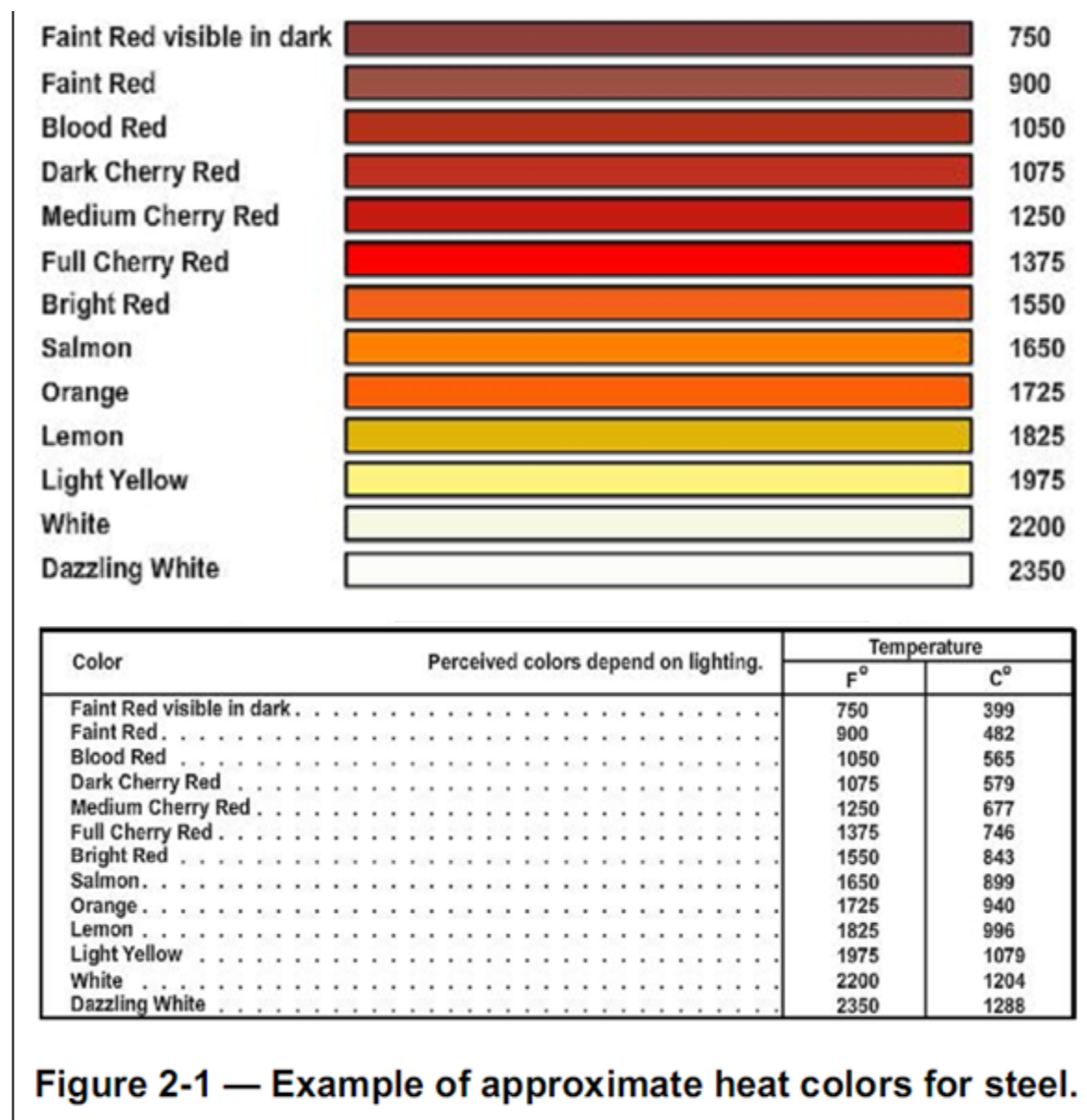

3.4. Types of Heat Treatment processes

Basic types of heat treatment are used today. They are annealing, normalizing, hardening, tempering and surface hardening, and others (austempering, martempering, etc). More of them can be shown below figures 2.

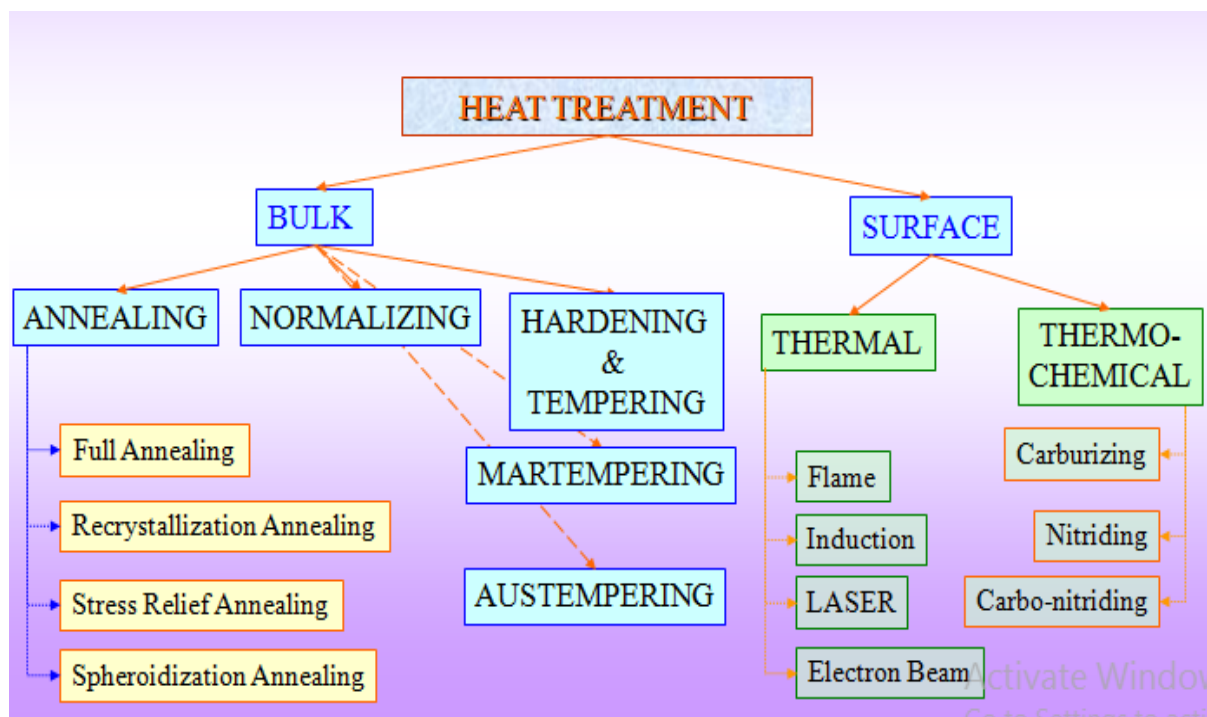

Fig. 2 Types of heat treatment processes

ANNEALING

- In general, annealing is the opposite of hardening, you anneal metals to relieve internal stresses, soften them, make them more ductile, and improve their grain structures.
- Annealing consists of heating a metal to a specific temperature, holding it at that temperature for a set length of time, and then cooling the metal to room temperature.
- The cooling method depends on the metal and the properties desired. Some metals are furnace-cooled, and others are cooled by burying them in ashes, lime, or other insulating materials.

Purpose

- Reduce hardness and brittleness
- Alter the microstructure for a special property
- Soften the metal for better machinability
- Recrystallize cold worked (strain hardened) metals
- Relieve induced residual stresses

ANNEALING Types

- Full Annealing
- Recrystallization Annealing
- Stress Relief Annealing



- Spheroidization Annealing

Full Annealing

- The purpose of this heat treatment is to obtain a material with high ductility. A microstructure with coarse pearlite (i.e. pearlite having high interlamellar spacing) is endowed with such properties.
- The range of temperatures used is given in the figure 3 belows.
- The steel is heated above A_3 (for hypo-eutectoid steels) & A_1 (for hyper-eutectoid steels) → (hold) → then the steel is furnace cooled to obtain Coarse Pearlite.
- Coarse Pearlite has low (\downarrow) Hardness but high (\uparrow) Ductility.
- For hyper-eutectoid steels the heating is not done above A_{cm} to avoid a continuous network of proeutectoid cementite along prior Austenite grain boundaries (presence of cementite along grain boundaries provides easy path for crack propagation).

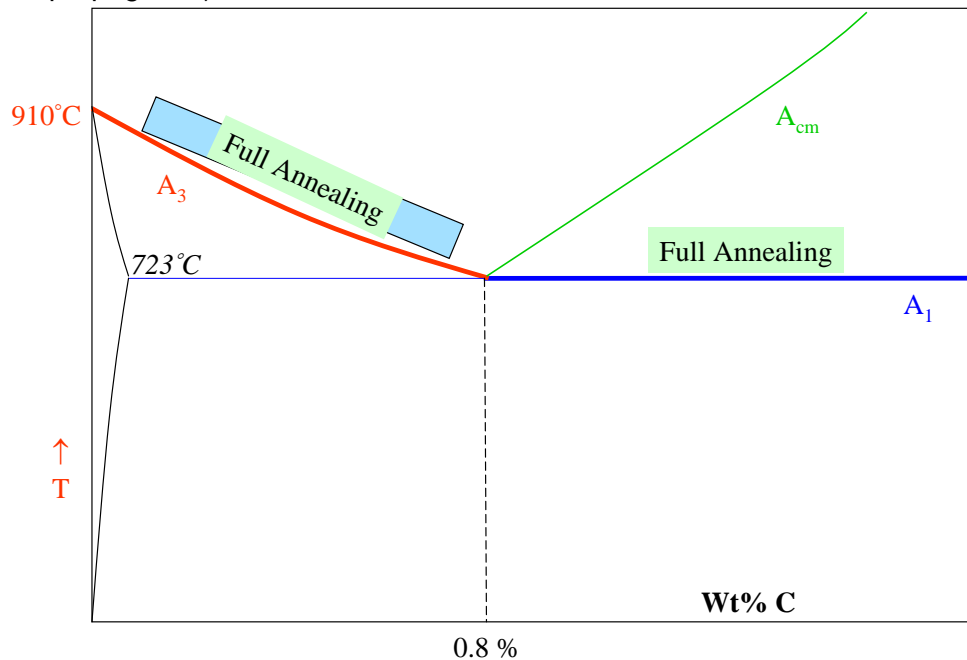

Fig. 3. Shows full annealing

Recrystallization Annealing

- During any cold working operation (say cold rolling), the material becomes harder (due to work hardening), but loses its ductility. This implies that to continue deformation the material needs to be recrystallized (wherein strain free grains replace the 'cold worked grains').
- Hence, recrystallization annealing is used as an intermediate step in (cold) deformation processing. Show in the below figure 4.

- To achieve this sample is heated below A_1 and held there for sufficient time for recrystallization to be completed.

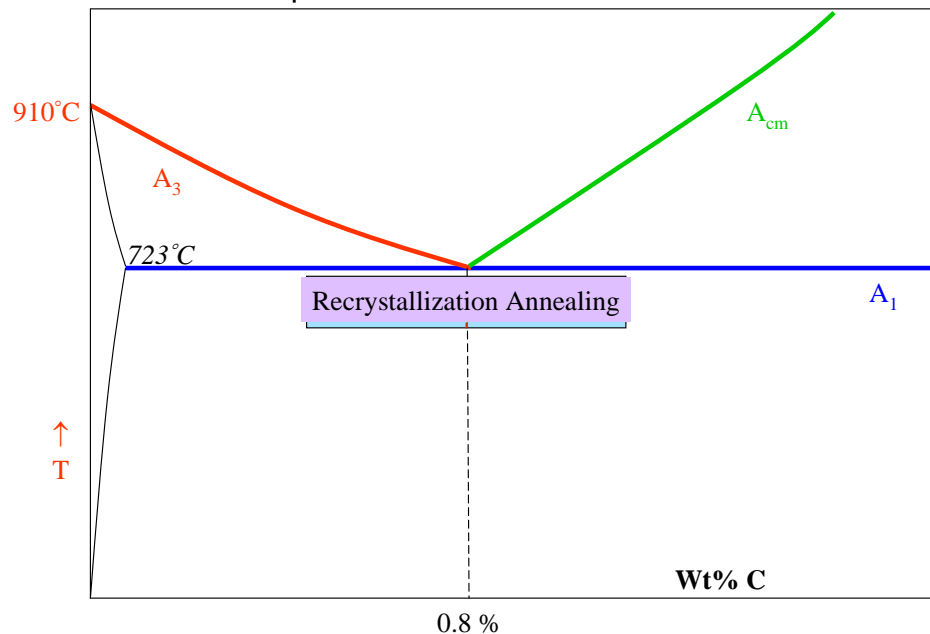

Fig.4. Shows Recrystallization annealing

Stress Relief Annealing

- Due to various processes like quenching (differential cooling of surface and interior), machining, phase transformations (like martensitic transformation), welding, etc. The residual stresses develop in the sample. Residual stress can lead to undesirable effects like warpage of the component. shown bellow fig.5.
- The annealing is carried out just below A_1 , wherein 'recovery*' processes are active (Annihilation of dislocations, polygonization).

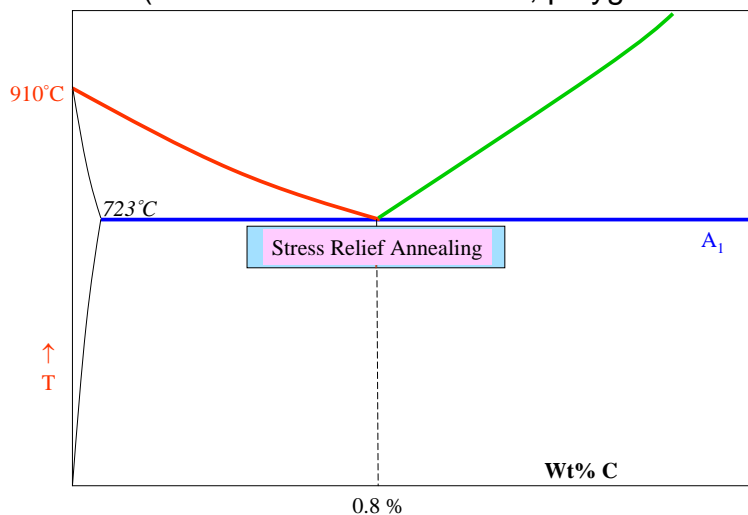

Fig.5. show at which stress relief annealing will be occurs

Spheroidization Annealing



- This is a very specific heat treatment given to high carbon steel requiring extensive machining prior to final hardening & tempering. The main purpose of the treatment is to increase the ductility of the sample.
- Like stress relief annealing the treatment is done just below A_1 . See fig.6.
- Long time heating leads cementite plates to form cementite spheroids. The driving force for this (microstructural) transformation is the reduction in interfacial energy.

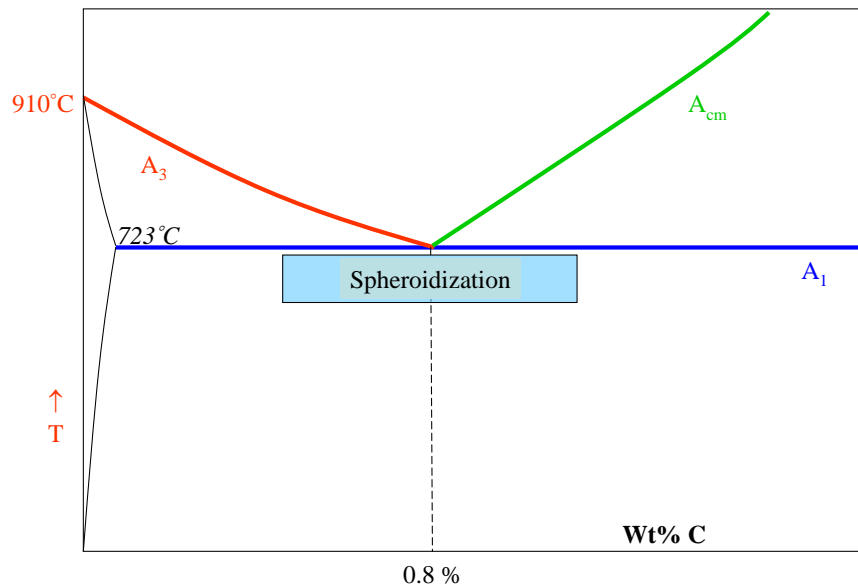

Fig.6. shows the spheroidization annealing

NORMALIZING

- Normalizing is a type of heat treatment applicable to ferrous metals only. It differs from annealing in that the metal is heated to a higher temperature and then removed from the furnace for air cooling.
- The purpose of normalizing is to remove the internal stresses induced by heat treating, welding, casting, forging, forming, or machining. Stress, if not controlled, leads to metal failure; therefore, before hardening steel, you should normalize it first to ensure the maximum desired results.
- The sample is heat above A_3 | A_{cm} to complete Austenization. The sample is then air cooled to obtain Fine pearlite. Fine pearlite has a reasonably good hardness and ductility. See below fig.7.
- In hypo-eutectoid steels normalizing is done 50°C above the annealing temperature.
- In hyper-eutectoid steels normalizing done above A_{cm} → due to faster cooling cementite does not form a continuous film along GB.

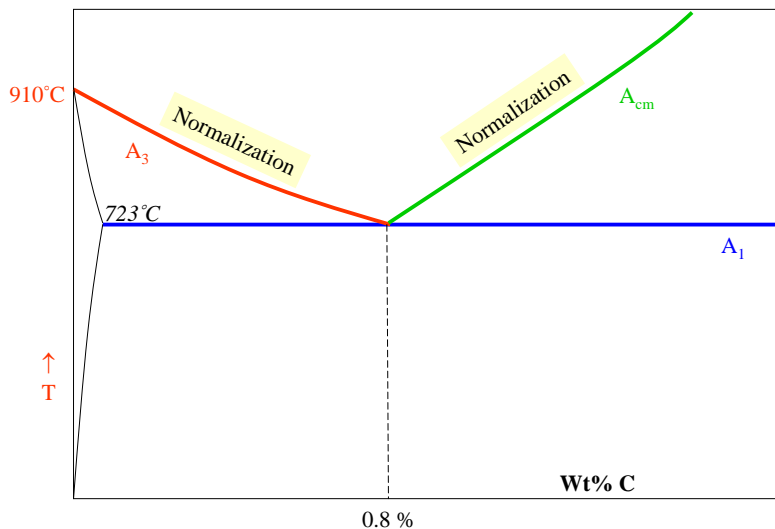

Fig.7. shows the normalization place

HARDENING

- The hardening treatment for most steels consists of heating the steel to a set temperature and then cooling it rapidly by plunging it into oil, water, or brine. Most steels require rapid cooling (quenching) for hardening but a few can be air-cooled with the same results. Hardening increases the hardness and strength of the steel, but makes it less ductile. Generally, the harder the steel, the more brittle it becomes. To remove some of the brittleness, you should **temper** the steel after hardening.
- The sample is heated above A_3 | A_{cm} to cause Austenization. The sample is then quenched at a cooling rate higher than the critical cooling rate (i.e. to avoid the nose of the CCT diagram).
- The quenching process produces residual strains (thermal, phase transformation).
- The transformation to Martensite is usually not complete and the sample will have some retained Austenite. See below fig.8.
- The Martensite produced is hard and brittle and tempering operation usually follows hardening. This gives a good combination of strength and toughness.
- Some purpose of hardening ; to harden the steel slightly, refine grain structure to hardening, to reduce segregation in casting or forgings, etc.

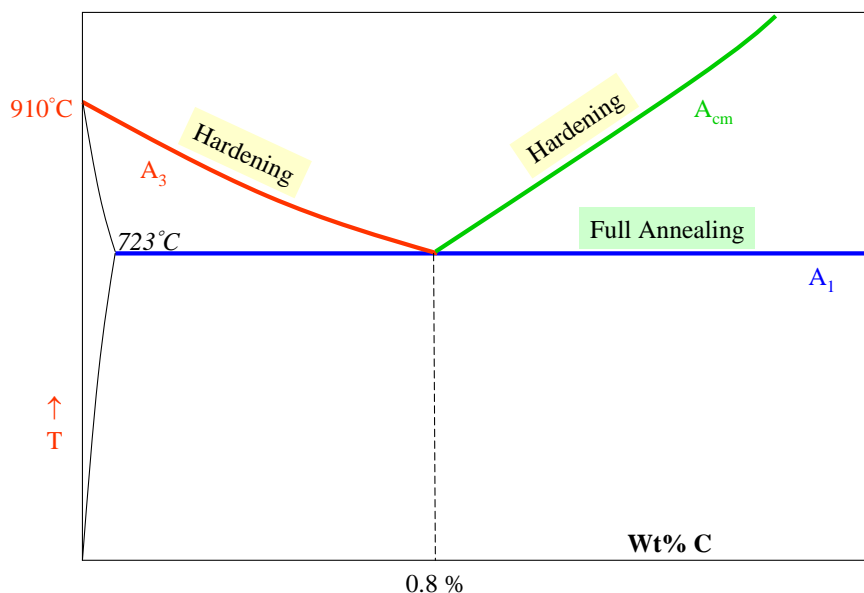

Fig.8. shows hardening takes place

TEMPERING

- After the hardening treatment is applied, steel is often harder than needed and is too brittle for most practical uses. Internal stresses are set up during the rapid cooling from the hardening temperature. To relieve the internal stresses and reduce brittle-ness, you should temper the steel after it is hardened. Tempering consists of heating the steel to a specific temperature (below its hardening temperature), holding it at that temperature for the required length of time, and then cooling it, usually instill air. The resultant strength, hardness, and ductility depend on the temperature to which the steel is heated during the tempering process.
- Heat below Eutectoid temperature → wait → slow cooling
- The microstructural changes which take place during tempering are very complex
- Time temperature cycle chosen to optimize strength and toughness
- Tool steel: As quenched (R_c 65) → Tempered (R_c 45-55)
- The purpose of tempering is to reduce the brittleness imparted by hardening and to produce definite physical properties within the steel.

NB. To remove some of the brittleness from hardened steels, tempering is used. The metal is heated to the range of 220-300 degrees and cooled,

Surface Hardening

Sometimes called case hardening, Case hardening produces a hard, wear-resistant surface or a “thermo chemical” treatment whereby the surface is altered by the addition of carbon, nitrogen, or other elements. Materials of surface hardening only ferrous metals are case-hardened. Commonly applied to low carbon steels for **get a hard wear resistant shell,**



and **tough inner core.**

- The common techniques; Carburizing, cyaniding, Nitriding, Carbonitriding, Chromizing, flame hardening, boronizing, induction hardening, etc.

Carburizing

- Heating a low carbon steel in the presence of carbon rich environment at temperature ~ 900°C
- This results in carburized steel that has a high-carbon surface and a low-carbon interior.
- When the carburized steel is heat-treated, the case becomes hardened and the core remains soft and tough. Two methods are used for carburizing steel.
- One method consists of heating the steel in a furnace containing a carbon monoxide atmosphere.
- The other method has the steel placed in a container packed with charcoal or some other carbon-rich material and then heated in a furnace. therefore
 - ✓ Carbon diffuses into the surface
 - ✓ End up with a high carbon steel surface.
 - ✓ Pack parts in a compartment with coke or charcoal
 - ✓ Gas carburizing
- Uses propane (C_3H_8) in a sealed furnace: Liquid carburizing, Used NaCN, $BaCl_2$, Thickness 0.005 in. to 0.030 in

CYANIDING

- This process is a type of case hardening that is fast and efficient. Preheated steel is dipped into a heated cyanide bath and allowed to soak.
- This process produces a thin, hard shell that is harder than the one produced by carburizing and can be completed in 20 to 30 minutes vice several hours. The major drawback is that cyanide salts are a toxic.

NITRIDING

- Nitrogen is diffused in the surface of special alloy steels at temperatures around ~510°C. Steel must contain elements that will form nitride compounds. Aluminum, Chromium
- It differs from the other methods in that the individual parts have been heat-treated and tempered before nitriding. The parts are then heated in a furnace that has an ammonia gas atmosphere. No quenching is required so there is no worry about warping or other types of distortion. This process is used to case harden items, such as gears, cylinder sleeves, camshafts and other engine parts, that need to be wear resistant and operate in high-heat areas. Forms a thin hard case without quenching, Thicknesses 0.001 in – 0.020 in.



Chromizing

- Diffuse chromium into the surface 0.001 – 0.002 in.
- Pack the parts in Cr rich powders or dip in a molten salt bath containing Cr salts.

Bronizing

- Performed on tool steels, nickel and cobalt based alloy steels.
- When used on low carbon steels, corrosion resistance is improved.

Flame Hardening

Flame hardening is another procedure that is used to harden the surface of metal parts. When you use an oxyacetylene flame, a thin layer at the surface of the part is rapidly heated to its critical temperature and then immediately quenched by a combination of a water spray and the cold base metal. This process produces a thin, hardened surface, and at the same time, the internal parts retain their original properties. Whether the process is manual or mechanical,

QUENCHING

Steel parts are rapidly cooled from the austenitizing or solution treating temperature. Stainless and high-alloy steels may be quenched to minimize the presence of grain boundary carbides or to improve the ferrite distribution, but most steels, including carbon, low-alloy, and tool steels, are quenched to produce controlled amounts of martensite in the microstructure. The ability of a quenchant to harden steel depends upon the cooling characteristics of the quenching medium. Quenching effectiveness is dependent on steel composition, type of quenchant, or quenchant use conditions, as well as the design and maintenance of a quenching system.

QUENCHING MEDIA

Selection of a quenchant depends on the hardenability of the steel, section thickness and shape involved, and the cooling rates needed to achieve the desired microstructure. Typically, quenchants are liquids (water, oil that could contain a variety of additives, aqueous polymer solutions, and water that could contain salt or caustic additives), and gases (inert gases including helium, argon, and nitrogen). Other quenchants include fogs and fluidized beds. The common medias water, brine, oil, and air.

You can use **water** to quench some forms of steel, but water is not recommended for **tool steel or other alloy steels**. Water absorbs large quantities of atmospheric gases, which have a tendency to form bubbles on the metal's surface when you quench a hot piece. Quenching liquids must be maintained at uniform temperatures; this is particularly true for oil. Many commercial operations that use oil-quenching tanks maintain the oil bath at their proper temperature by circulating the oil medium through coils that themselves are water cooled. Self contained coolers are an integral part of large quench tanks.

Page 60 of 105	Federal TVET Agency Author/Copyright	TVET program title- Machining Level -2	Version -1 October 2019
----------------	---	--	----------------------------

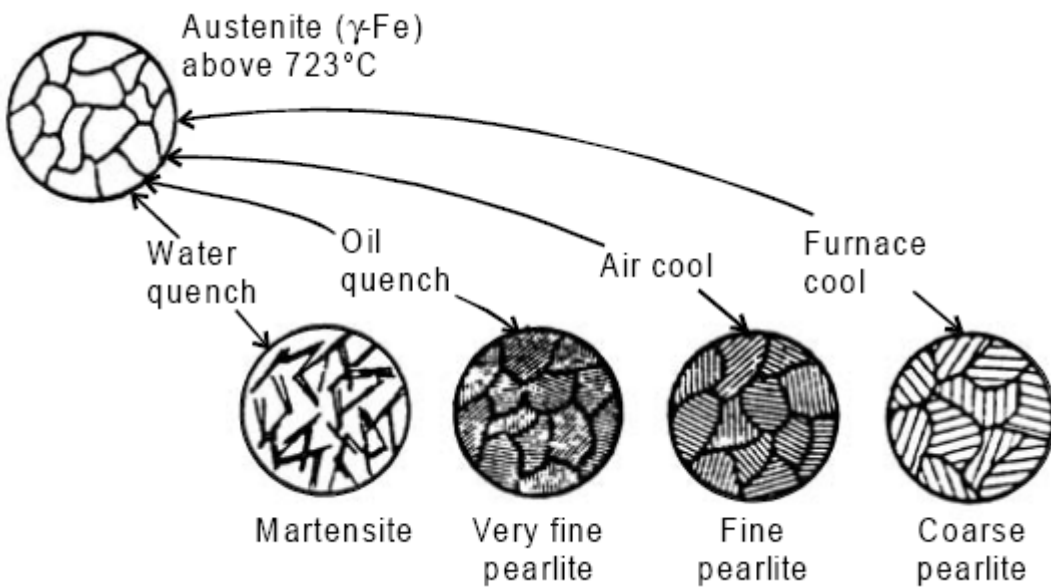

Figure; Effects of cooling of austenite transformation

Defects and distortion of heat treating

Defects and Distortion in Heat-Treated Parts most of the problems in heat treated parts are attributed to faulty heat treatment practices such as overheating and burning, and non uniform heating and quenching, deficiency in the grade of steels used, part defect, improper grinding, and/or poor part design.



Self-Check -2	Written Test
----------------------	---------------------

Directions: Answer all the questions listed below. Use the Answer sheet provided in the next page

1. What process consists of tempering, normalizing, hardening, and annealing?
 - A. Cold forming of metals
 - B. Heating treatment of nonferrous metals
 - C. Heat treatment of ferrous metal
 - D. Quenching of austenitic materials
2. Which of the following conditions is required for the successful heat treatment of metal?
 - A. proper size of furnace
 - B. proper furnace atmosphere
 - C. suitable quenching medium
 - D. all of the above
3. (True or False) To make a metal more useful, heat treating can make it stronger, more resistant to impact, malleable, and ductile with one process.
 - A. True
 - B. False
4. Which one of the following are stages / cycle of heat treatment.
 - A. Cooling
 - B. Heating
 - C. Soaking
 - D. All
5. Reduce the hardness, improve machine ability, and facilitate cold-working
 - A. Hardening
 - B. Normalizing
 - C. Annealing
 - D. Tempering
6. The steel is heated above A_3
 - A. Full annealing
 - B. Spheroids annealing
 - C. Flame annealing
 - D. Intermediate annealing
7. It is make structure more uniform, or to improve mach inability.
 - A. Hardening
 - B. Normalizing
 - C. Annealing
 - D. Tempering
8. It is cooling it rapidly from a temperature above the transformation temperature.
 - A. Hardening
 - B. Normalizing
 - C. Annealing
 - D. Tempering
9. It is not Quenching media?
 - A. Brunel
 - C. Oil



B. Water

D. Air

10. The component is shielded surrounded by a carbon-rich compound and placed in the furnace.

A. Case hardening

C. Induction hardening

B. Flame carburizing

D. Pack carburizing

11. Heat below Eutectoid temperature → wait → slow cooling

A. Hardening

C. Annealing

B. Normalizing

D. Tempering

II. Matching column A from column B

Column A

1. Increase strength and wear resistance
2. Increase toughness
3. Obtain fine grain size
4. Remove internal stresses
5. Improve machine ability
6. Improve cutting properties of tool steels hardening
7. Improve surface properties
8. Improve electrical properties
9. Improve magnetic properties
10. Increase ductility and softness

Column B

- A. Hardening, phase transformation
- B. Tempering, annealing
- C. Tempering, age hardening
- D. Full annealing and normalizing
- E. Stress relief annealing
- F. Bulk hardening, surface
- G. Surface hardening
- H. Hardening and tempering

Note: Satisfactory rating - 5 points

Unsatisfactory - below 5 points



Information Sheet-4	Heat treating materials as required
----------------------------	--

4.1. INTRODUCTION

Steel can be processed to produce a large variety of microstructures and properties. The required results are achieved by heating the material in temperature ranges where a phase or combination of phases is stable (producing microstructural changes or distribution of stable phases) and / or heating or cooling between temperature ranges in which different phases are stable (producing beneficial phase transformations). The iron-carbon equilibrium phase diagram is the foundation on which all steel heat treatment is based. The diagram defines the temperature-composition regions where the various phases in steel are stable, as well as the equilibrium boundaries between phase fields.

4.2. Classification metals

The commonly heat treated metals they are classified in to two types ferrous and non ferrous metals.

- Ferrous metals like, steel, cast iron, alloys, stainless steel, tool steel.
- Non ferrous metals like, aluminum, copper, brass, titanium.

Heat treating is a vital part of manufacturing. Thus, it is critical for any organization that relies on this technology to understand the relationship that exists between the variables that influence product response to heat treatment; **namely material choice, properties, part design, manufacturing practices and heat-treating methods.**

4.3. HEAT TREATMENT OF FERROUS METALS

Transformation temperature is the temperature at which a change in phase occurs. The term is sometimes used to denote the limiting temperature of a transformation range. The following symbols are used for iron and steels. A_{cm} . In hypereutectoid steel, the temperature at which the solution of cementite in austenite is completed during heating

A_{c1} . The temperature at which austenite begins to form during heating, with the c being derived from the French chauffant.

A_{c3} . The temperature at which transformation of ferrite to austenite is completed during heating

$A_{e_{cm}}$, A_{e1} , A_{e3} . The temperatures of phase changes at equilibrium

Page 64 of 105	Federal TVET Agency Author/Copyright	TVET program title- Machining Level -2	Version -1 October 2019
----------------	---	--	----------------------------



Arcm. In hypereutectoid steel, the temperature at which precipitation of cementite starts during cooling, with ther being derived from the French refroidissant

Ar1. The temperature at which transformation of austenite to ferrite or to ferrite plus cementite is completed during cooling

Ar3. The temperature at which austenite begins to transform to ferrite during cooling.

Ar4. The temperature at which delta ferrite transforms to austenite during cooling

Ms(or Ar "). The temperature at which transformation of austenite to martensite starts during cooling

Mf. The temperature at which martensite formation finishes during cooling

Note: All of these changes, except the formation of martensite, occur at lower temperatures during cooling than during heating and depend on the rate of change of temperature.

IRON-CARBON EQUILIBRIUM PHASE DIAGRAM

The basis for understanding the heat treatment of steels is the iron-carbon (Fe-C) phase diagram. The Fe-C diagram is really two diagrams in one, showing the equilibrium between cementite (iron carbide, or Fe₃C) and the several phases of iron, as well as the equilibrium between graphite and the other phases. Steels are alloys of iron, carbon and other elements that contain less than 2% carbon (usually less than 1%), therefore the portion of the diagram below 2% C; that is, the iron-cementite (Fe-Fe₃C) diagram, is more pertinent to steel heat treatment. In cast irons, high carbon content (1.75-4.0%C) and high silicon content promote graphite formation. Therefore, cast iron technology is based more on the Fe-graphite diagram.

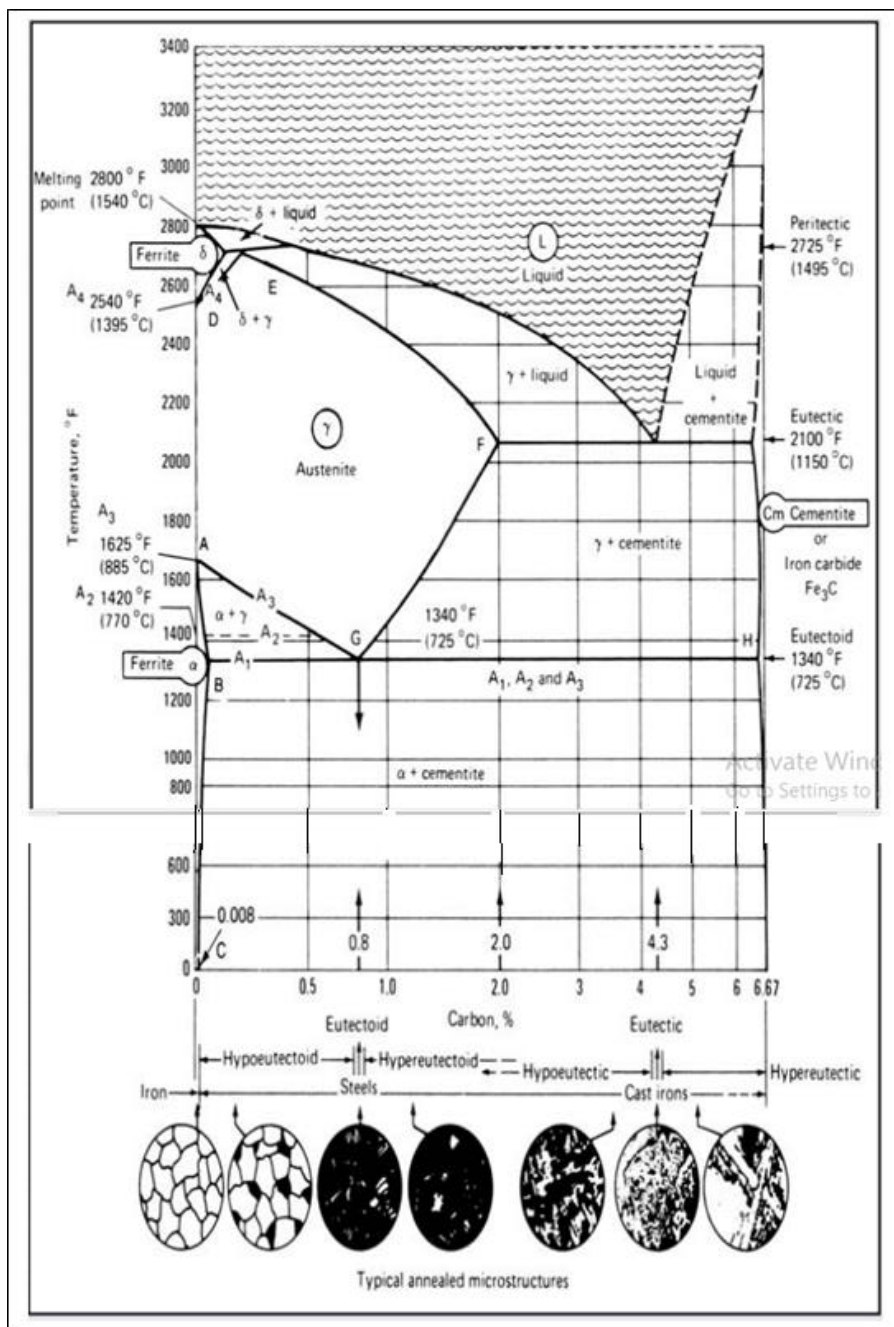

Fig. 1. Expanded iron-carbon phase diagram showing both the eutectoid, and eutectic regions.

Heat Treating of Carbon Steels

heat treatment of steel or other iron-base alloys, it is helpful to explain what steel is. The common dictionary definition is “a hard, tough metal composed of iron, alloyed with various small percentage of carbon and often variously with other metals such as nickel, chromium, manganese, etc.” Although this definition is not untrue, it is hardly adequate. All steels are mixtures, or more properly, alloys of iron and carbon.



There are only three phases involved in any steel—ferrite, carbide (cementite), and austenite, whereas there are several structures or mixtures of structures.

Classification of Steels

It is impossible to determine the precise number of steel compositions and other variations that presently exist, although the total number probably exceeds 1000; thus, any rigid classification is impossible. However, steels are arbitrarily divided into five groups, which has proved generally satisfactory to the metalworking community.

These five classes are:

- Carbon steels
- Alloy steels (sometimes referred to as low-alloy steels)
- Stainless steels
- Tools steels
- Special-purpose steels

Crystals structures (grains size and composition)

Metallic materials consist of a microstructure of small crystals called "grains" or crystallites. The nature of the grains (i.e. grain size and composition) is one of the most effective factors that can determine the overall mechanical behavior of the metal. **Heat treatment provides an efficient way to manipulate the properties of the metal by controlling the rate of diffusion and the rate of cooling within the microstructure.** Heat treating is often used to alter the mechanical properties of a metallic alloy, manipulating properties such as the hardness, strength, toughness, ductility, and elasticity.

There are two mechanisms that may change an alloy's properties during heat treatment: the formation of martensite causes the crystals to deform intrinsically, and the diffusion mechanism causes changes in the homogeneity of the alloy.

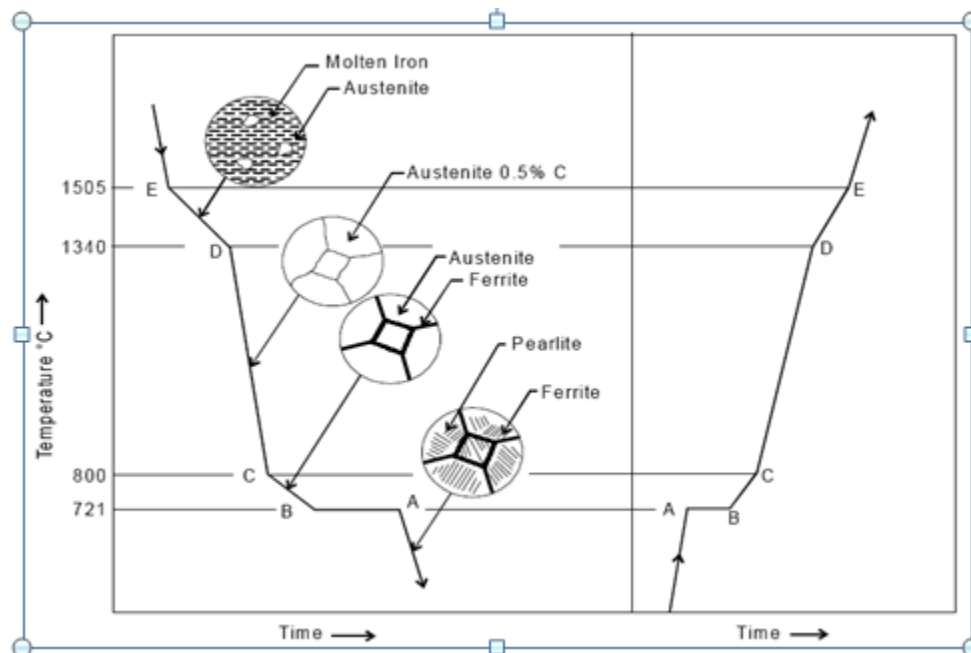

Fig.2. Heating and cooling curve of steel

The crystal structure consists of atoms that are grouped in a very specific arrangement, called a lattice. In most elements, this order will rearrange itself, depending on conditions like temperature and pressure. This rearrangement, called allotropy or polymorphism, may occur several times, at many different temperatures for a particular metal. In alloys, this rearrangement may cause an element that will not normally dissolve into the base metal to suddenly become soluble, while a reversal of the allotropy will make the elements either partially or completely insoluble.

When in the soluble state, the process of diffusion causes the atoms of the dissolved element to spread out, attempting to form a homogenous distribution within the crystals of the base metal. If the alloy is cooled to an insoluble state, the atoms of the dissolved constituents (solutes) may migrate out of the solution. This type of diffusion, called precipitation, leads to nucleation, where the migrating atoms group together at the grain-boundaries. This forms a microstructure generally consisting of two or more distinct phases. For instance, steel that has been heated above the austenizing temperature (red to orange-hot, or around 1,500 °F (820 °C) to 1,600 °F (870 °C) depending on carbon content), and then cooled slowly, forms a laminated structure composed of alternating layers of ferrite and cementite, becoming soft pearlite. After heating the steel to the austenite phase and then quenching it in water, the microstructure will be in the martensitic phase. This is due to the fact that the steel will change from the austenite phase to the martensite phase after quenching. Some pearlite or ferrite may be present if the quench did not rapidly cool off all the steel. Unlike iron-based alloys, most heat treatable alloys do not experience a ferrite transformation. In these alloys, the nucleation at the grain-boundaries often reinforces



the structure of the crystal matrix. These metals harden by precipitation. Typically a slow process, depending on temperature, this is often referred to as "age hardening".

Many metals and non-metals exhibit a martensite transformation when cooled quickly (with external media like oil, polymer, water etc.). When a metal is cooled very quickly, the insoluble atoms may not be able to migrate out of the solution in time. This is called a "diffusionless transformation." When the crystal matrix changes to its low temperature arrangement, the atoms of the solute become trapped within the lattice. The trapped atoms prevent the crystal matrix from completely changing into its low temperature allotrope, creating shearing stresses within the lattice. When some alloys are cooled quickly, such as steel, the martensite transformation hardens the metal, while in others, like aluminum, the alloy becomes softer.

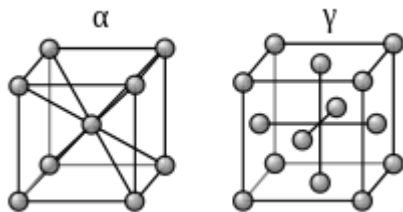

Fig.3. Allotropes of iron, showing the differences in lattice structures between alpha iron (low temperature) and gamma iron (high temperature). The alpha iron has no spaces for carbon atoms to reside, while the gamma iron is open to free movement of small carbon atoms.

Effects of composition of metal

The specific composition of an alloy system will usually have a great effect on the results of heat treating. If the percentage of each constituent is just right, the alloy will form a single, continuous microstructure upon cooling. Such a mixture is said to be **eutectoid**. However, if the percentage of the solutes varies from the eutectoid mixture, two or more different microstructures will usually form simultaneously. A hypoeutectoid solution contains less of the solute than the eutectoid mix, while a hypereutectoid solution contains more.

Eutectoid alloys

A eutectoid (eutectic-like) alloy is similar in behavior to a eutectic alloy. A eutectic alloy is characterized by having a single melting point. This melting point is lower than that of any of the constituents, and no change in the mixture will lower the melting point any further. When a molten eutectic alloy is cooled, all of the constituents will crystallize into their respective phases at the same temperature.

A eutectoid alloy is similar, but the phase change occurs, not from a liquid, but from a solid solution. Upon cooling a eutectoid alloy from the solution temperature, the



constituents will separate into different crystal phases, forming a single microstructure. A eutectoid steel, for example, contains 0.77% carbon. Upon cooling slowly, the solution of iron and carbon (a single phase called austenite) will separate into platelets of the phases ferrite and cementite. This forms a layered microstructure called pearlite. Since pearlite is harder than iron, the degree of softness achievable is typically limited to that produced by the pearlite. Similarly, the hardenability is limited by the continuous martensitic microstructure formed when cooled very fast.

Hypoeutectoid alloys

A hypoeutectic alloy has two separate melting points. Both are above the eutectic melting point for the system, but are below the melting points of any constituent forming the system. Between these two melting points, the alloy will exist as part solid and part liquid. The constituent with the lower melting point will solidify first. When completely solidified, a hypoeutectic alloy will often be in solid solution.

Similarly, a hypoeutectoid alloy has two critical temperatures, called "arrests." Between these two temperatures, the alloy will exist partly as the solution and partly as a separate crystallizing phase, called the "proeutectoid phase." These two temperatures are called the upper (A_3) and lower (A_1) transformation temperatures. As the solution cools from the upper transformation temperature toward an insoluble state, the excess base metal will often be forced to "crystallize-out," becoming the proeutectoid. This will occur until the remaining concentration of solutes reaches the eutectoid level, which will then crystallize as a separate microstructure.

A hypoeutectoid steel contains less than 0.77% carbon. Upon cooling a hypoeutectoid steel from the austenite transformation temperature, small islands of proeutectoid-ferrite will form. These will continue to grow and the carbon will recede until the eutectoid concentration in the rest of the steel is reached. This eutectoid mixture will then crystallize as a microstructure of pearlite. Since ferrite is softer than pearlite, the two microstructures combine to increase the ductility of the alloy. Consequently, the hardenability of the alloy is lowered.

Hypereutectoid alloys

A hypereutectic alloy also has different melting points. However, between these points, it is the constituent with the higher melting point that will be solid. Similarly, a hypereutectoid alloy has two critical temperatures. When cooling a hypereutectoid alloy from the upper transformation temperature, it will usually be the excess solutes that crystallize-out first, forming the proeutectoid. This continues until the concentration in the remaining alloy becomes eutectoid, which then crystallizes into a separate microstructure. A hypereutectoid steel contains more than 0.77% carbon. When slowly cooling a hypereutectoid steel, the cementite will begin to crystallize first. When the

remaining steel becomes eutectoid in composition, it will crystallize into pearlite. Since cementite is much harder than pearlite, the alloy has greater hardenability at a cost in the ductility.

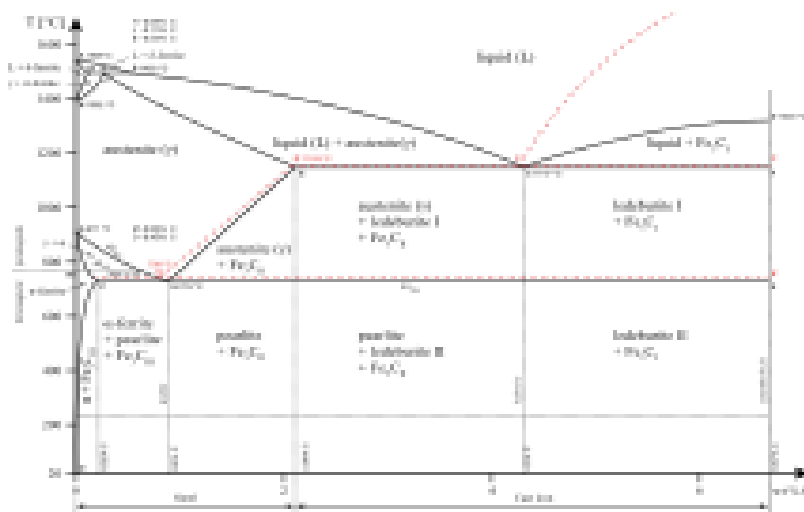

Fig.4. Phase diagram of an iron-carbon alloying system. Phase changes occur at different temperatures (vertical axis) for different compositions (horizontal axis). The dotted lines mark the eutectoid (A) and eutectic (B) compositions

Effects of time and temperature

Proper heat treating requires precise control over temperature, time held at a certain temperature and cooling rate. With the exception of stress-relieving, tempering, and aging, most heat treatments begin by heating an alloy beyond a certain transformation, or arrest (A), temperature. This temperature is referred to as an "arrest" because at the A temperature the metal experiences a period of hysteresis. At this point, all of the heat energy is used to cause the crystal change, so the temperature stops rising for a short time (arrests) and then continues climbing once the change is complete.^[13] Therefore, the alloy must be heated above the critical temperature for a transformation to occur. The alloy will usually be held at this temperature long enough for the heat to completely penetrate the alloy, thereby bringing it into a complete solid solution. Iron, for example, has four critical-temperatures, depending on carbon content. Pure iron in its alpha (room temperature) state changes to nonmagnetic gamma-iron at its A_2 temperature, and weldable delta-iron at its A_4 temperature. However, as carbon is added, becoming steel, the A_2 temperature splits into the A_3 temperature, also called the austenizing temperature (all phases become austenite, a solution of gamma iron and carbon) and its A_1 temperature (austenite changes into pearlite upon cooling). Between these upper and lower temperatures the proeutectoid phase forms upon cooling.

Because a smaller grain size usually enhances mechanical properties, such as toughness, shear strength and tensile strength, these metals are often heated to a temperature that is just above the upper critical-temperature, in order to prevent the

grains of solution from growing too large. For instance, when steel is heated above the upper critical-temperature, small grains of austenite form. These grow larger as temperature is increased. When cooled very quickly, during a martensite transformation, the austenite grain-size directly affects the martensitic grain-size. Larger grains have large grain-boundaries, which serve as weak spots in the structure. The grain size is usually controlled to reduce the probability of breakage.

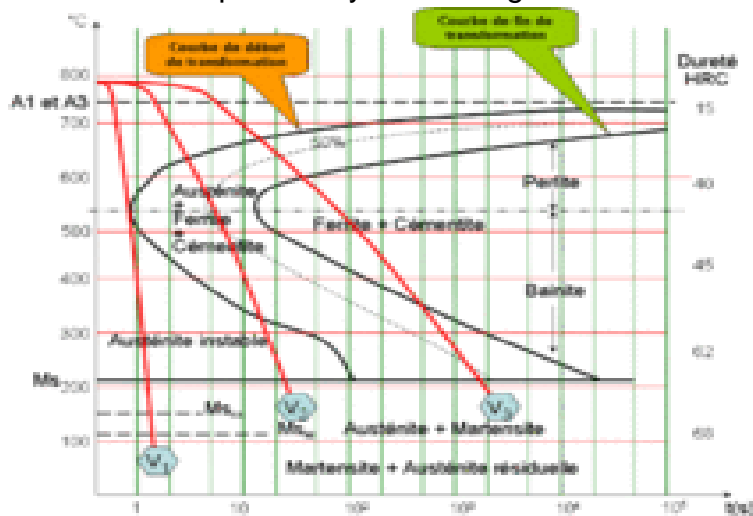

Fig.5. Time-temperature transformation (TTT) diagram for steel. The red curves represent different cooling rates (velocity) when cooled from the upper critical (A3) temperature. V1 produces martensite. V2 has pearlite mixed with martensite, V3 produces bainite, along with pearlite and matensite.

The diffusion transformation is very time-dependent. Cooling a metal will usually suppress the precipitation to a much lower temperature. Austenite, for example, usually only exists above the upper critical temperature. However, if the austenite is cooled quickly enough, the transformation may be suppressed for hundreds of degrees below the lower critical temperature. Such austenite is highly unstable and, if given enough time, will precipitate into various microstructures of ferrite and cementite. The cooling rate can be used to control the rate of grain growth or can even be used to produce partially martensitic microstructures. However, the martensite transformation is time-independent. If the alloy is cooled to the martensite transformation (M_s) temperature before other microstructures can fully form, the transformation will usually occur at just under the speed of sound.

When austenite is cooled slow enough that a martensite transformation does not occur, the austenite grain size will have an effect on the rate of nucleation, but it is generally temperature and the rate of cooling that controls the grain size and microstructure. When austenite is cooled extremely slow, it will form large ferrite crystals filled with spherical inclusions of cementite. This microstructure is referred to as "spheroidite." If cooled a little faster, then coarse pearlite will form. Even faster, and fine pearlite will

form. If cooled even faster, bainite will form. Similarly, these microstructures will also form if cooled to a specific temperature and then held there for a certain time.

Most non-ferrous alloys are also heated in order to form a solution. Most often, these are then cooled very quickly to produce a martensite transformation, putting the solution into a supersaturated state. The alloy, being in a much softer state, may then be cold worked. This causes work hardening that increases the strength and hardness of the alloy. Moreover, the defects caused by plastic deformation tend to speed up precipitation, increasing the hardness beyond what is normal for the alloy. Even if not cold worked, the solutes in these alloys will usually precipitate, although the process may take much longer. Sometimes these metals are then heated to a temperature that is below the lower critical (A_1) temperature, preventing recrystallization, in order to speed-up the precipitation.

Carbon steels

Structures in Fe-C-diagram

The main microscopic constituents of iron and steel are as follows:

1. Austenite
2. Ferrite
3. Cementite
4. Pearlite

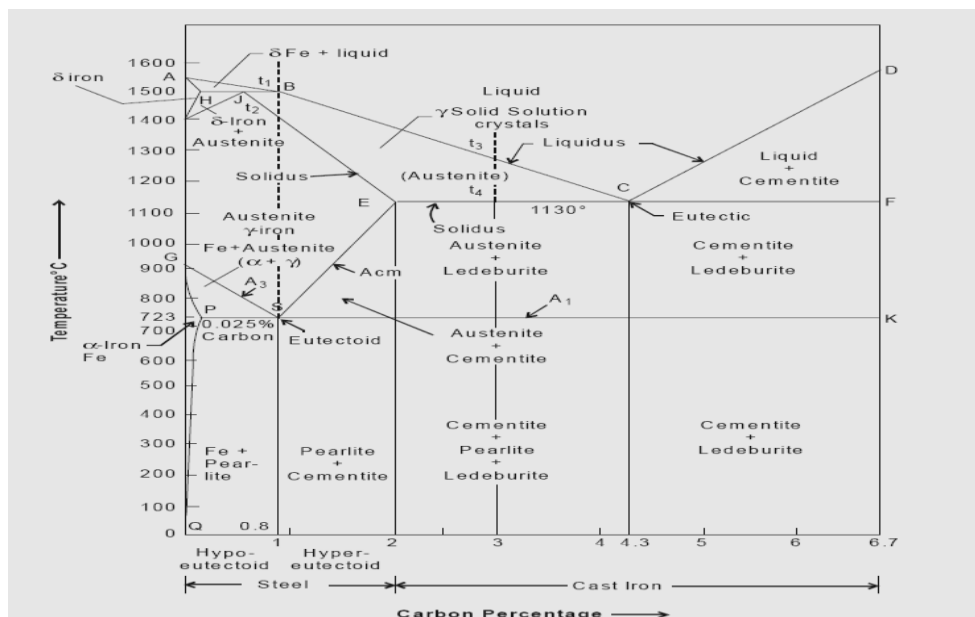

Fig.6. Iron-carbon equilibrium diagram

Austenite

Austenite is a solid solution of free carbon (ferrite) and iron in gamma iron. On heating the steel, after upper critical temperature, the formation of structure completes into



austenite which is hard, ductile and non-magnetic. It is able to dissolve large amount of carbon. It is in between the critical or transfer ranges during heating and cooling of steel. It is formed when steel contains carbon up to 1.8% at 1130°C. On cooling below 723°C, it starts transforming into pearlite and ferrite. Austenitic steels cannot be hardened by usual heat treatment methods and are non-magnetic.

Ferrite

Ferrite contains very little or no carbon in iron. It is the name given to pure iron crystals which are soft and ductile. The slow cooling of low carbon steel below the critical temperature produces ferrite structure. Ferrite does not harden when cooled rapidly. It is very soft and highly magnetic.

Cementite

Cementite is a chemical compound of carbon with iron and is known as iron carbide (Fe_3C). Cast iron having 6.67% carbon is possessing complete structure of cementite. Free cementite is found in all steel containing more than 0.83% carbon. It increases with increase in carbon % as reflected in Fe-C Equilibrium diagram. It is extremely hard. The hardness and brittleness of cast iron is believed to be due to the presence of the cementite. It decreases tensile strength. This is formed when the carbon forms definite combinations with iron in form of iron carbides which are extremely hard in nature. The brittleness and hardness of cast iron is mainly controlled by the presence of cementite in it. It is magnetic below 200°C.

Pearlite

Pearlite is a eutectoid alloy of ferrite and cementite. It occurs particularly in medium and low carbon steels in the form of mechanical mixture of ferrite and cementite in the ratio of 87:13. Its hardness increases with the proportional of pearlite in ferrous material. Pearlite is relatively strong, hard and ductile, whilst ferrite is weak, soft and ductile. It is built up of alternate light and dark plates. These layers are alternately ferrite and cementite. When seen with the help of a microscope, the surface has appearance like pearl, hence it is called pearlite. Hard steels are mixtures of pearlite and cementite while soft steels are mixtures of ferrite and pearlite.

As the carbon content increases beyond 0.2% in the temperature at which the ferrite I first rejected from austenite drop until, at or above 0.8% carbon, no free ferrite is rejected from the austenite. This steel is called eutectoid steel, and it is the pearlite structure in composition.

As iron having various % of carbon (up to 6%) is heated and cooled, the following phases representing the lines will tell the about the structure of iron, how it charges



Self-Check -2	Written Test
----------------------	---------------------

Directions: Answer all the questions listed below. Use the Answer sheet provided in the next page

1. (True or False) Steel can be tempered provided some hardness remains after it has been normalized.
 - A. True
 - B. False
2. The steel is heated above A_3
 - A. Full annealing
 - B. Spheroids annealing
 - C. Flame annealing
 - D. Intermediate annealing

3.

What are the most important properties to be obtained in tempering permanent steel magnets?

- A. Stability and malleability
- B. Softness and malleability
- C. Hardness and stability
- D. Ductility and resistance to wear

What effect is produced when steel is cooled very slowly in a medium that does NOT conduct heat easily?

- A. Maximum softness
- B. Maximum hardness
- C. Maximum ductility
- D. Minimum ductility

Note: Satisfactory rating - 5 points

Unsatisfactory - below 5 points



Operation Sheet 1	Performing hardness distribution in quenched mild steel
--------------------------	--

Step/ procedure of steel shaft a) hardness distribution in quenched mild steel
b) Hardness distribution in quenched and tempered mild steel

- Step 1- Identifying / interpreting work / job sheet requirements.
- Step 2- Selecting heating equipment and PPE.
- Step 3- Metal needed inspecting composition contents / grating types
- Step 4- Heating the furnace as operation procedure with recommended temperature.
- Step 5- Has to follow soaking, cooling system as requirement

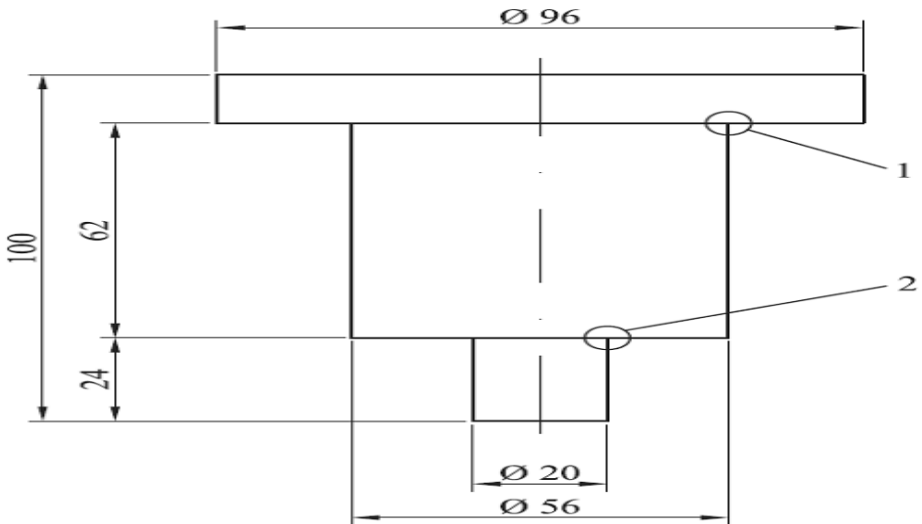

Fig.1. Geometry of steel shaft

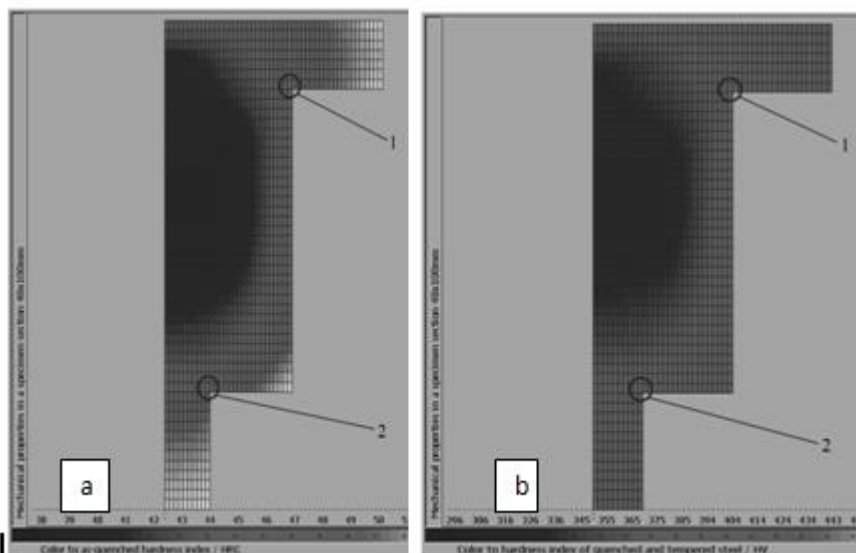

Fig.2. a) hardness distribution in quenched mild steel , b)Hardness distribution in quenched and tempered mild steel

Table 1.
Chemical composition of steel 42CrMo4 (EN)

Chemical composition/wt.%						
C	Si	Mn	P	S	Cr	Mo
0.38	0.23	0.64	0.019	0.013	0.99	0.16

Table 2.
Jominy test results of steel 42CrMo4 (EN)

Jominy distance/mm	1.5	3	5	7	9	11	13	15	20	25	30
Hardness HRC	55	54	54	53	51	49	47	45	39	35	33
Jominy distance/mm	35	40	45	50	55	60	65	70	75	80	-
Hardness HRC	32	31	30	29	29	29	29	29	29	29	-

Table 3.
Parameters of heat treatment of shaft

Austenitizing			Quenching		Tempering		
Temperature	Time	Media	Media	Temperature	Time	Media	
850°C	1 hour	air	oil, H = 0.35	480°C	1 hour	air	

Table 4.
Mechanical properties in critical locations of quenched and tempered steel shaft

Properties	Critical location in Figures 3, 4 and 5	
	1	2
Hardness HV	383	384
Tensile strength R_m /Nmm ⁻²	1264	1267
Yield strength R_p /Nmm ⁻²	1067	1071
Percent elongation A /%	8.6	8.5
Percent reduction of area Z /%	49.3	49.3
Fracture toughness K_{Ic} /MPam ^{1/2}	107	107



Operation Sheet 2	1035—Recommended Heat Treating Practice
--------------------------	--

Procedures for 1035—Recommended Heat Treating Practice

- Step 1- Identifying / interpreting work / job sheet requirements.
- Step 2- Selecting heating equipment and PPE.
- Step 3- Metal needed inspecting composition contents / grating types and cleaning metal
- Step 4- Heating the furnace as operation procedure with recommended temperature.
- Step 5- Has to follow soaking, cooling system as requirement

Operating by this specification

Normalizing, if required, is accomplished by heating to 915 °C (1675F) and cooling in still air.

Annealing. Heat to 870 °C (1600 °F). Furnace cool at a rate not exceeding 28 °C (50 °F) per hour to 650 °C (1200 °F).

Hardening. Austenitize at 855 °C (1575 F). Quench in water or brine, except for sections under 6.35 mm (1/4 in.), which may be oil quenched.

Tempering. As-quenched hardness should be approximately 45 HRC. Hardness can be adjusted downward by tempering (see curve in Fig. 4).

Table 4 Compositions of standard carbon H-steels and standard carbon boron H-steels

Steel designation AISI or SAE	UNS No.	Chemical composition, %				
		C	Mn	P max	S max	Si
Standard carbon H-steels						
1038H	H10380	0.34–0.43	0.50–1.00	0.040	0.050	0.15–0.30
1045H	H10450	0.42–0.51	0.50–1.00	0.040	0.050	0.15–0.30
1522H	H15220	0.17–0.25	1.00–1.50	0.040	0.050	0.15–0.30
1524H	H15240	0.18–0.26	1.25–1.75(a)	0.040	0.050	0.15–0.30
1526H	H15260	0.21–0.30	1.00–1.50	0.040	0.050	0.15–0.30
1541H	H15410	0.35–0.45	1.25–1.75(a)	0.040	0.050	0.15–0.30
Standard carbon boron H-steels						
15B21H	H15211	0.17–0.24	0.70–1.20	0.040	0.050	0.15–0.30
15B35H	H15351	0.31–0.39	0.70–1.20	0.040	0.050	0.15–0.30
15B37H	H15371	0.30–0.39	1.00–1.50	0.040	0.050	0.15–0.30
15B41H	H15411	0.35–0.45	1.25–1.75(a)	0.040	0.050	0.15–0.30
15B48H	H15481	0.43–0.53	1.00–1.50	0.040	0.050	0.15–0.30
15B62H	H15621	0.54–0.67	1.00–1.50	0.040	0.050	0.40–0.60

(a) Standard AISI-SAE H-steels with 1.75 manganese maximum are classified as carbon steels. Source: Ref 1

**Techniques for 1020—Recommended Heat Treating Practice**

Step 1- Identifying / interpreting work / job sheet requirements.

Step 2- Selecting heating equipment and PPE.

Step 3- Metal needed inspecting composition contents / grating types and cleaning metal

Step 4- Heating the furnace as operation procedure with recommended temperature.

Step 5- Has to follow soaking, cooling system as requirement

Operating by this specification

Normalizing. Heat to 925 °C (1700 °F). Air cool.

Annealing. Heat to 870 °C (1600 °F). Cool slowly, preferably in furnace.

Hardening. Can be case hardened by any one of several processes, which range from light case hardening, such as carbonitriding and the others described for grade 1008, to deeper case carburizing in gas, solid, or liquid mediums. Most carburizing is done in a gaseous mixture of methane combined with one of several carrier gases, using the temperature range of 870 to 955 °C (1600 to 1750 °F). Carburize for desired case depth with a 0.90 carbon potential. Case depth achieved is always a function of time and temperature. For most furnaces, a temperature of 955 °C (1750 °F) approaches the practical maximum without causing excessive deterioration in the furnace. With the advent of vacuum carburizing, temperatures up to 1095 °C (2000 °F) can be used to develop a given case depth in about one-half the time required at the more conventional temperature of 925 °C (1700 °F) (see Chapter 8 of practical heat treating).

Hardening after carburizing is usually achieved by quenching directly into water or brine from the carburizing temperature. After the desired carburizing cycle had been completed, the furnace temperature can be decreased or a lower temperature zone can be used for a continuous furnace to 845 °C (1550 °F) for a diffusion cycle. Quenching into water or brine then tempering at 150 °C (300 °F) follows.



LAP Test	Practical Demonstration
-----------------	--------------------------------

Name: _____ Date: _____

Time started: _____ Time finished: _____

Instructions: Given necessary templates, tools and materials you are required to perform the following tasks within --- hour.

Task 1. Performing hardness distribution in quenched mild steel

Task 2. Performing 1035—Recommended Heat Treating Practice

Task N. Performing 1020—Recommended Heat Treating Practice



Instruction Sheet	Learning Guide #37
--------------------------	---------------------------

This learning guide is developed to provide you the necessary information regarding the following **content coverage** and topics –

- Testing heat treated material
- Clearing work area and disposing/recycling materials
- Cleaning, checking, maintaining and storing tools and equipment
- Completing documentation

This guide will also assist you to attain the learning outcome stated in the cover page.

Specifically, upon completion of this Learning Guide, **you will be able to –**

- Test heat treated material for required result in accordance with standard operating procedures
- Clean work area and dispose of/or recycle materials in accordance with legislation and workplace procedures
- Clean, check, maintain and store tools and equipment in accordance with manufacturers' recommendations and workplace procedures
- Complete documentation in accordance with workplace requirements

Learning Instructions:

1. Read the specific objectives of this Learning Guide.
2. Follow the instructions described below.
3. Read the information written in the “Information Sheets”. Try to understand what are being discussed. Ask your trainer for assistance if you have hard time understanding them.
4. Accomplish the “Self-checks” which are placed following all information sheets.
5. Ask from your trainer the key to correction (key answers) or you can request your trainer to correct your work. (You are to get the key answer only after you finished answering the Self-checks).



Information Sheet-1	Testing heat treated material
----------------------------	--------------------------------------

1.1. Introduction

A successful heat treating operation is determined by the ability to satisfy the customer's quality requirements consistently and economically. Quality requirements may be defined by such characteristics as hardness, dimensions, surface condition, uniformity, properties, microstructure, and so forth.

1.2. Testing method of heat treated material

Heat treat testing is performed to assess a material's response to a heat treatment process in order to certify the material to specified requirements.

Selecting the proper tests may involve tradeoffs due to cost or time. Be sure you understand the cost/benefit relationship of each test and what the expected outcome might be so that the right choices can be made. Insist on specificity to avoid open ended analysis efforts. Here are some examples of what can be done in the laboratory.

- Stereomicroscopy
- Nondestructive testing
 - ✓ Eddy current
 - ✓ Ultrasonic
 - ✓ Pressure testing (hydrostatic, pneumatic)
 - ✓ Surface finish
- Mechanical testing
 - ✓ Hardness (Rockwell, Brinell & Superficial methods) testing
 - ✓ Tensile testing
 - ✓ Impact testing (e.g., Charpy and Izod testing)
 - Fatigue testing
 - Torque/torque-tension
 - Shear and double shear strength
 - Torsion testing
 - Creep
 - Stress rupture and stress durability
 - Vibratory testing
- Optical microscopy
 - ✓ Microstructural determination
 - ✓ Grain size
 - ✓ Micro cleanliness
 - ✓ Intergranular attack



- ✓ Inclusion characterization
- ✓ Alpha case

1.2.1. Destructive test methods

When the steel is hardened and tempered, its strength is affected, so let us take a closer look at how these properties are measured.

- **Hardness testing**

Hardness testing is the most popular way to check the results of hardening. Hardness is usually the property that is specified when a tool is hardened. It is easy to test hardness. The material is not destroyed and the apparatus is relatively inexpensive. The most common methods are Rockwell C (HRC), Vickers (HV) and, Brinell (HBW).

The old expression “file-hard” should not be entirely forgotten.

In order to check whether hardness is satisfactory, for example above 60 HRC, a file of good quality can provide a good indication.

- ✓ **ROCKWELL (HRC)**

This method is suitable for hardened material and never for material in soft annealed condition. In Rockwell hardness testing, a conical diamond is first pressed with a force F_0 , and then with a force F_0+F_1 against a specimen of the material which hardness is to be determined. After unloading to F_0 , the increase (e) of the depth of the impression caused by F_1 is determined. The depth of penetration (e) is converted into a hardness number (HRC) which is read directly from a scale on the tester dial or read-out.

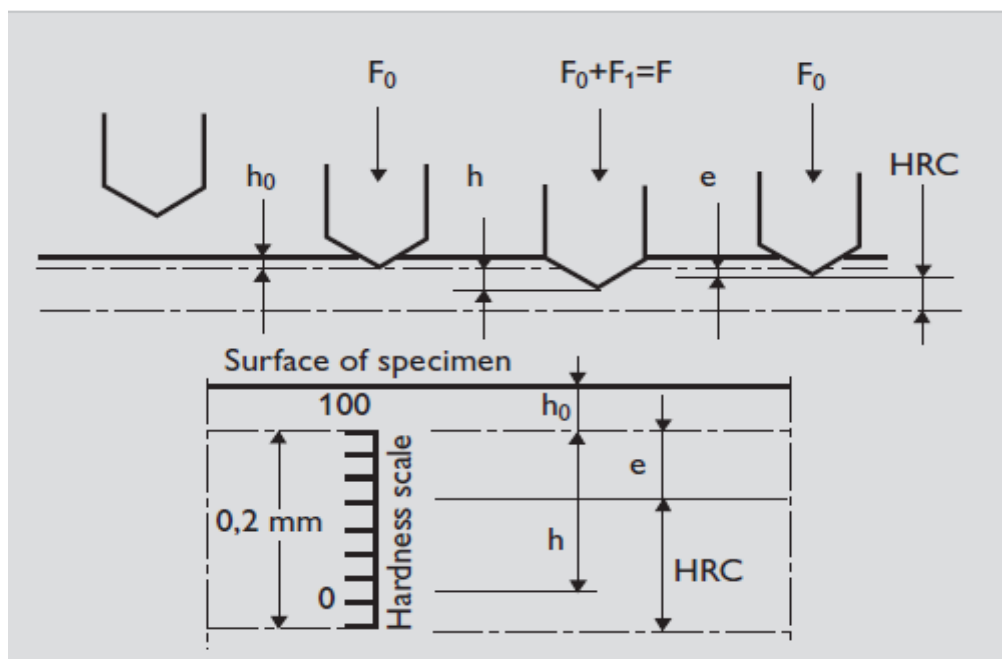



Fig.1. Principle of Rockwell hardness testing

✓ **VICKERS (HV)**

Vickers is the most universal of the three testing methods. In Vickers hardness testing a pyramid shaped diamond with a square base and a peak angle of 136° is pressed under a load F against the material whose hardness is to be determined. After unloading, the diagonals d_1 and d_2 of the impression are measured and the hardness number (HV) is read off a table. When the test results are reported, Vickers hardness is indicated with the letters HV and a suffix indicating the mass that exerted the load and (when required) the loading period, as illustrated by the following example HV 30/20 = Vickers hardness determined with a load of 30 kgf exerted for 20 seconds.

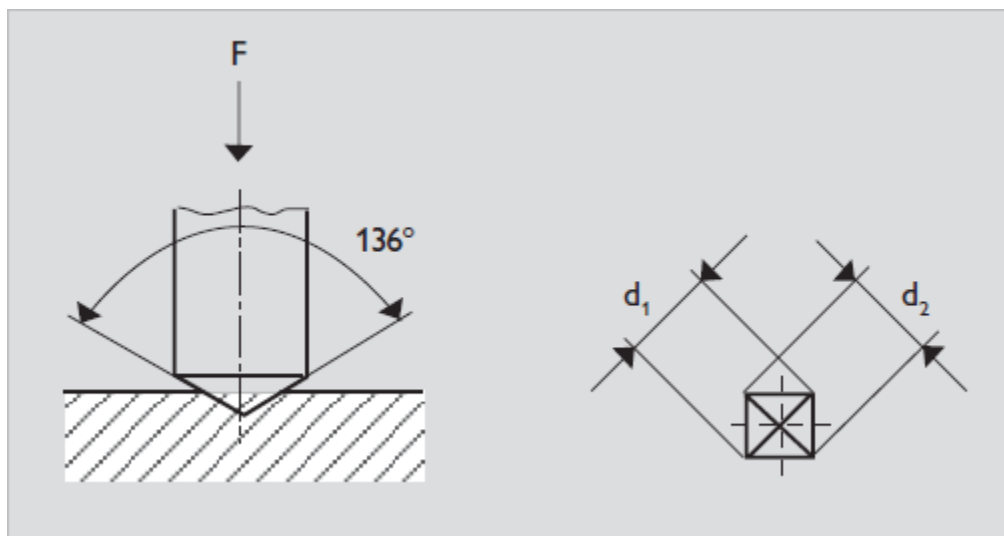

Fig.2. Principle of Vickers hardness testing

✓ **BRINELL (HBW)**

This method is suitable for soft annealed condition and pre hardened steel with relatively low hardness. In Brinell hardness testing, a tungsten (W) ball is pressed against the material whose hardness is to be determined. After unloading, two measurements of the diameter of the impression are taken at 90° to each other (d_1 and d_2) and the HBW value is read off a table, from the average of d_1 and d_2 .

When the test results are reported, Brinell hardness is indicated with the letters HBW and a suffix indicating ball diameter, the mass with which the load was exerted and (when required) the loading period, as illustrated by the following example: HBW 5/750/15 = Brinell hardness determined with 5 mm tungsten (W) ball and under load of 750 kgf exerted for 15 seconds.

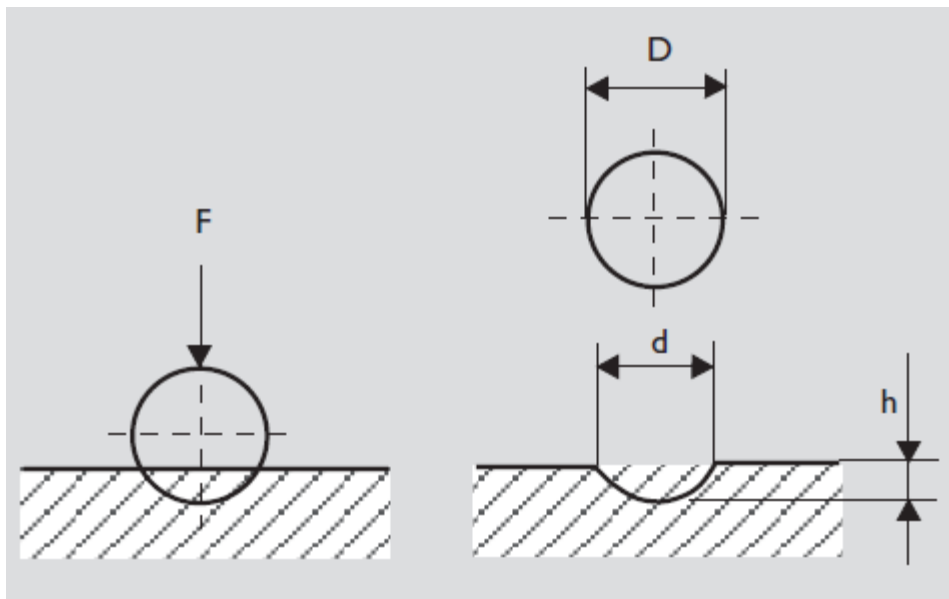

Fig.3. Principle of Brinell hardness testing

- **Tensile Testing**

Hardness testing is one of the oldest and most reliable measures of whether or not a component part has been successfully heat treated. However, it should not be the only test conducted to confirm this is true. One of the most reliable mechanical tests to help us to predict the behavior of a component under various operating conditions is the simple tensile test.

The tensile test allows us to measure a material's response to loading and deformation. By measuring the force required to elongate a specimen to its breaking point, material properties can be determined that will allow engineering designers and quality managers to predict how their materials and products will behave in their intended end-use applications. Examples of products and industries that use tensile testing include fasteners (e.g., bolts, nuts, screws), seat-belt components, and tubing and pipe manufacturers to name a few. Tensile tests can predict pull-off force, peel and tear resistance and adhesion/bond strength. In the test, one end of a specimen is typically clamped in a load frame while the other end is subjected to a controlled displacement or a controlled load. A transducer or servo-drive connected in series with the specimen provides information about the displacement (d) as a function of the load (P) applied (or vice versa).

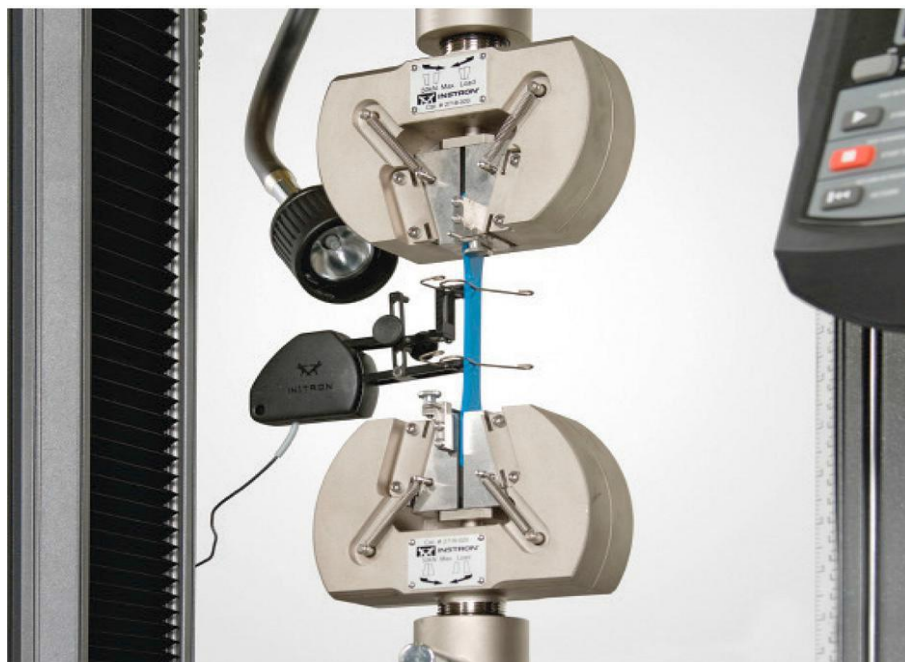

Fig.4. Tensile-testing apparatus for fasteners [2]
(Photograph courtesy of Instron™)

Tensile-Testing Standards

There are a number of tensile-testing standards, including:

- ASTM B913, D76, D1876, D3822, D412, D638, D828, E8
- BS 5G 178, BS EN 1895
- ISO 37, 527, 1924, 13934
- MIL-C-39029, MIL-T-7928

Stress-Strain Curves

Stress-strain curves (Fig. 2) can then be generated and divided into “regions” that are descriptive of what is happening on the microscopic level, namely:

- Elastic region
- Plastic region
 - ✓ Yielding
 - ✓ Strain hardening
 - ✓ Necking
- Failure (fracture)

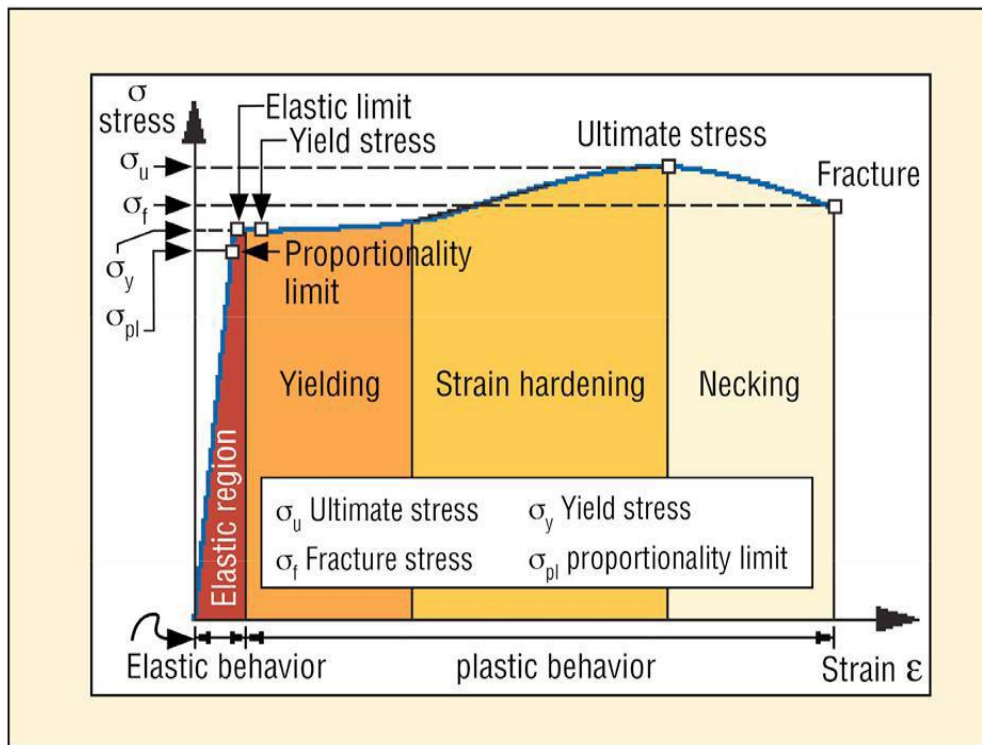

Fig. 5. Various regions and points on the stress-strain curve

- **Impact Testing**

Strength and toughness relationships are perhaps the most important ones when it comes to advances in materials and engineered products. Toughness is often determined by impact testing, and every heat treater needs to know how these tests are performed and what they mean.

Impact testing provides us with a simple method of ascertaining the change in the fracture mode of a material as a function of temperature. An analysis of the fracture surface of an impact specimen can characterize the fracture mode. Impact tests measure both the energy required and the resistance to failure of a material subjected to a sudden applied load. The test measures the impact energy; that is, the energy absorbed by the material prior to fracture. The two most common tests are the Charpy test and the Izod test.

- ✓ **The Charpy Test**

This test is named for its inventor, Georges Augustin Albert Charpy (1865-1945). The Charpy test measures the energy absorbed by a standard notched specimen while breaking under a three-point bending impact load. The most common method of measuring impact energy in steels today is the Charpy V-notch test (Fig.2a). Other notch configurations (U-notch, keyhole, etc.) can be used. The importance of the

Charpy impact tests lies in the fact that it can reproduce the ductile-brittle transition transformation (DBTT) in essentially the same temperature range as it is actually observed in engineering structures.

✓ The Izod Test

The Izod impact test was named for its inventor, Edwin Gilbert Izod (1876-1946), and consists of a pendulum with a determined weight at the end of its arm swinging down in a circular arc and striking a specimen while it is held securely in a vertical position (Fig. 2b). It is a cantilever beam test in which the notch is oriented to point in the direction of load approach. The impact strength is determined by the loss of energy of the pendulum as calculated by precisely measuring the loss of height in the pendulum's swing. The specimen that is usually notched is gripped at one end only, which is the principal difference between it and the Charpy test.

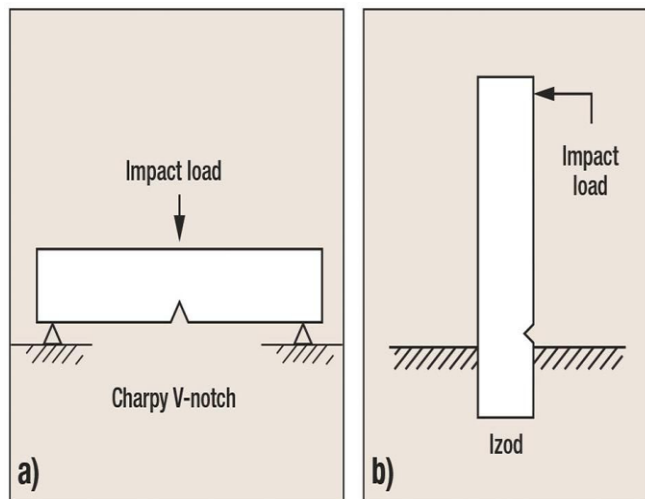

Fig. 6. Method of loading for impact tests[2]
(a) Charpy; (b) Izod



Fig. 7. Instrumented impact pendulum system for Charpy testing (courtesy of Instron)

1.2.2. Non destructive test (NDT) methods

Some common methods are visual, microscopy, liquid or dye penetrant inspection, magnetic particle inspection, eddy current testing, x-ray or radiographic testing, and ultrasonic testing

- **Visual Inspection**

Visual inspection provides a means of detecting and examining a variety of surface flaws, such as corrosion, contamination, surface finish, and surface discontinuities on joints (for example, welds, seals, and solder connections). Visual inspection is also the most widely used method for detecting and examining surface cracks that are



particularly important because of their relationship to structural failure mechanisms. Even when other inspection techniques are used to detect surface cracks, visual inspection often provides a useful supplement.

1.3. Importance

Final inspection is necessary to verify that specifications have been met, but testing of as-received material and in-process testing are important to determine whether a problem occurred during processing and at what stage it occurred. It is certainly uneconomical to complete an expensive heat treatment only to find a problem that could have been caught in an early stage of processing. From strictly an economic point of view, the part being heat treated generally has a value of 10 to 20 times the actual cost of the heat treatment; therefore, if a heat treating operation produces a scrap rate of only 1 to 2%, any profit from that operation is lost.

1.3.1. Components of a Quality Assurance Program

The components of a program to ensure quality in heat treating should include:

- Selection of proper material and design of the part being treated
- Use of the proper equipment and control of its operation (control of heat treating processes is discussed in “Instrumentation and Control of Heat Treating Processes”)
- A determination whether the process is capable of heat treatment to the required specification
- Use of statistical process control (SPC), control charting, and in process inspection and testing
- Statistical quality control (SQC) and final testing (sampling) to verify the results.

Final inspection is to ensure that the specified properties have been met. If proper attention has been paid to the control of incoming material and equipment and processing variables, there should be no surprises at this stage. Final inspection may involve much more extensive tests than those used during in-process testing (physical, mechanical, or destructive). Generally, the customer determines what properties should be evaluated and what final tests should be carried out.

1.4. Necessary tools and equipments

- Hardness testing (Rockwell, Brinell & Superficial methods)
- Tensile testing (100 lbs. up to 600,000 lbs.)
- Fracture toughness testing
- Temperature Calibration Too (pyrometry)

--	--



Self-Check -2	Written Test
----------------------	---------------------

Directions: Answer all the questions listed below. Use the Answer sheet provided in the next page

1. Heat treated material testing need to determine the ability to satisfy the customer's quality requirements.
A. True B. False
2. From the listed which one is not distractive testing?
A. Hardness testing
B. Impact testing
C. Tensile strength testing
D. None of the above
3. From the listed which one is not non distractive testing?
A. Eddy current
B. Ultrasonic
C. Surface finish
D. None of the

Note: Satisfactory rating - 5 points

Unsatisfactory - below 5 points

Answer Sheet

Name: _____

Date: _____

Score = _____

Rating: _____



Information Sheet-2	Clearing work area and disposing/recycling materials
----------------------------	--

1.5. Introduction

Reinstate the work area on completion of the preparation activities, to include carrying out all of the following:

- ✓ Safely disposing of waste materials
- ✓ Cleaning and returning all tools and excess materials
- ✓ Completing all required documentation

What is 5s?

5S are five terms beginning with “S” utilized to create a workplace suited for visual control and lean production.

5S is a systematized approach to organize work areas, keep rules and standards, and maintain the discipline needed to do a good job.

5S means good housekeeping and workplace organization

5S is a part of **Kaizen**.

Kaizen-Means continuous improvement (Kaizen comes from the Japanese words "Kai" meaning school and "Zen" meaning wisdom. Collectively, it means continuous improvement . . . in **quality, technology, processes, company culture, productivity, safety** and **leadership**.)

FOCUS OF 5S

- visual order
- organization
- cleanliness
- standardization

RESULTS OF 5S

- improved profitability
- efficiency
- service
- safety

Kaizen improves.

- product quality
- production capacity
- use of capital
- **Safety**
- **space utilization**

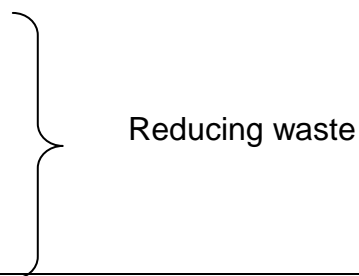

Reducing waste



- communications
- employee retention

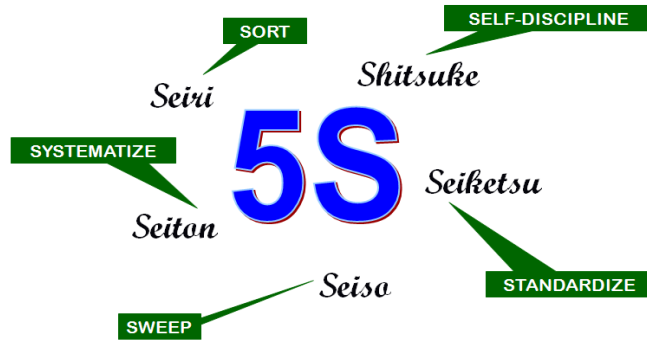

- **SEIRI (Sort)**

Taking out and disposing unnecessary items. Unneeded items are thrown away or disposed.

SORT basically means “Don't keep things around just because they might be used, someday.”

- **SEITON (Systematize/Stabilize/Straighten)**

Organization of necessary items in good order and easy access Items in the workplace are arranged for ease of access and repeated use.

SYSTEMATIZE is to neatly arrange and identify parts and tools for ease of use.

- **SEISO (Sweep/Shine)**

Cleaning of the workplace

Cleaning even if things are NOT DIRTY, A regular cleaning schedule prevents things from having the chance to get dirty.

- **SEIKETSU (Sanitize/Standardize)**

Maintaining the workplace in high standard of housekeeping

Standardize means to conduct Sort, Systematize, and Sweep at frequent, indeed daily, intervals to maintain a workplace in perfect condition.

- **SHITSUKE (Sustain/Self-Discipline)**

Doing things spontaneously without being told,

“Teach by doing.”

Page 92 of 105	Federal TVET Agency Author/Copyright	TVET program title- Machining Level -2	Version -1
			October 2019



Sustain means to form the habit of always following the first four Ss . . . To maintain what has been accomplished.

Carry out heat treatment pre/post preparation processes to include the following:

- ✓ Cleaning and removing all surface contamination
- ✓ Applying/removing any required masking/surface protection to areas not requiring heat treatment
- ✓ Carrying out drying or pre heating requirements
- ✓ Ensuring that materials/component to be immersed in hot treatment solutions are dry
- ✓ Carrying out/removing jiggling and hanging of component.

Page 93 of 105	Federal TVET Agency Author/Copyright	TVET program title- Machining Level -2	Version -1
			October 2019



Self-Check -2	Written Test
----------------------	---------------------

Directions: Answer all the questions listed below. Use the Answer sheet provided in the next page

1. (True or False) Steel can be tempered provided some hardness remains after it has been normalized.
 - A. True
 - B. False
2. The steel is heated above A_3
 - A. Full annealing
 - B. Spheroids annealing
 - C. Flame annealing
 - D. Intermediate annealing
- 3.

Note: Satisfactory rating - 5 points

Unsatisfactory - below 5 points

Answer Sheet

Score = _____

Rating: _____

Name: _____

Date: _____

Short Answer Questions



Information Sheet-3	Cleaning, checking, maintaining and storing tools and equipment
----------------------------	--

3.1. Introduction

The reliability of mechanical relays, timers, and push buttons exposed to dust, humidity, and other environmental plant factors was somewhat unpredictable and subject to frequent failure. A well-planned and executed preventative maintenance program was mandatory to keep malfunctions and furnace downtime to a minimum.

3.2. Cleaning, checking, maintaining

Cleaning is defined as the application of time, temperature, chemistry and energy to remove contamination from the surface of a part to a level appropriate for the intended application. In other words, cleaning is simply moving contaminants from where they are not wanted (on the parts) to where they should be (in the waste disposal system). If all four aspects of the cleaning process are not working together, the parts will not be properly cleaned. Although heat treating demands only a moderate level of cleanliness compared to many industries, contamination left on parts can cause significant problems in our equipment as well as in the end result (i.e., spotty hardness, uneven case, etc)

All cleaning systems depend on one or a combination of three basic actions:

- ✓ A physical action, that is, a mechanical force, such as spray agitation, dunking, ultrasonic methods, or even hand (abrasive) cleaning, to remove the contaminants from the part surface.
- ✓ A thermal action to improve the activity of the cleaning solution and increase the kinetic energy of the system.
- ✓ A chemical action to allow contaminants to be either desorbed from the part surfaces with the aid of surface active agents or dissolved by an action of absorption and dilution.

When to Perform Maintenance

The frequency of maintenance (i.e. interval between routine repairs) is highly dependent on such factors as the type and number of heat-treating processes performed; the skill of the operators; the equipment type and design; the quality of prior maintenance and type of spare parts used; and the quality of the water system and gas system from the supply to the equipment. Additionally, running clean parts and properly supporting parts in baskets or on grids often help reduce the frequency of maintenance.

Page 95 of 105	Federal TVET Agency Author/Copyright	TVET program title- Machining Level -2	Version -1
			October 2019



When performing maintenance it is important to understand why a particular task is necessary. Furthermore, the work should be signed off upon completion (which includes testing to ensure that the repair was successful).

Page 96 of 105	Federal TVET Agency Author/Copyright	TVET program title- Machining Level -2	Version -1
			October 2019



Preventive-Maintenance Checks

Setting up a planned preventive-maintenance program will minimize equipment downtime, ensure that proper spares are on hand for repairs and simplify the overall maintenance effort. As a minimum, the following checks should be performed at the specified interval.

In heat treating workshop maintain each run daylily, weekly, monthly, semiannually and annually has to check properly tools and equipment in accordance with manufacturers' recommendations and workplace procedures.

On furnaces in a captive heat-treat shop. The intent was to do a thorough inspection, cleaning, repair and modification (as necessary) of the furnace as a model to implement changes on. You have to perform Uniformity on many types of furnaces and ovens, including curing and drying ovens, batch furnaces, tooling furnaces and drying ovens for qualified of reliability.

One-stop for Temperature Calibration Too

The field technicians calibration division, provide pyrometry services to let you know if your furnaces, controllers and other temperature equipment are operating efficiently and accurately. The needed, our technicians can provide adjustments and repairs while at facility for temperature consistency throughout your equipment.

- Uniformity Surveys
- Temperature Controllers
- Recorders (Temperature, Digital, Chart)
- System Accuracy Tests

The work involved looking into the history of the furnace, major disassembly and cleaning, which included draining the quench tank and shoveling out the sludge accumulation from the bottom of the tank, as well as evaluating all of the components on the equipment.

Page 97 of 105	Federal TVET Agency Author/Copyright	TVET program title- Machining Level -2	Version -1 October 2019
----------------	---	--	----------------------------



Self-Check -2	Written Test
----------------------	---------------------

Directions: Answer all the questions listed below. Use the Answer sheet provided in the next page

1. _____ is simply moving contaminants from where they are not wanted.
A. Cleaning B. checking C. maintain
2. All cleaning systems depend on one or a combination them basic actions.
A. Mechanical B. thermal C. chemical D. All

Note: Satisfactory rating - 5 points

Unsatisfactory - below 5 points

Answer Sheet

Score = _____

Rating: _____

Name: _____

Date: _____

Short Answer Questions



Information Sheet-4	Completing documentation
----------------------------	---------------------------------

4.1 Introduction

As demand for increased quality and documentation has been experienced by heat treaters, the subject of automatic collection and use of process information in a SPC/SQC format has become mandatory. Data acquisition and documentation a few years ago meant a chart recorder for temperature and a log sheet for the operator's dew point readings. Today, it more than likely means a computer system tied into key points of the heat treating equipment and process with the objective of logging important information for later review or perhaps being taken into account in real time.

4.2 Documentation

A quality assurance system must designate which records are to be retained and must set down minimum time periods for retention of such records. It is usual for important documents to be retained (to keep in possession or uses) for 25 years or more. Retention time, however, should be consistent with real needs as dictated by projected lifetime of products or by legal requirements. Besides satisfying certain contractual or other legal requirements, retained records can provide important cost benefits to both producer and customer. Prior to repair was avoided when the fabricator was able to produce original drawing and material test reports.



Self-Check -2	Written Test
----------------------	---------------------

Directions: Answer all the questions listed below. Use the Answer sheet provided in the next page

1. (True or False) It is usual for important documents to be retained (to keep in possession or uses) for 25 years or more.
A. True B. False
2. Data acquisition and documentation a few years ago meant a _____ and a log sheet for the operator's _____.
 - i. Chart recorder for temperature B. dew point readings.

Note: Satisfactory rating - 5 points

Unsatisfactory - below 5 points

Answer Sheet

Score = _____
Rating: _____

Name: _____

Date: _____

Short Answer Questions



List of reference

ASM Handbook, Vol. 4, Heat Treating, ASM International, Materials Park, Ohio, 1991, pp. 3-4.

Practical Heat Treating, Second Edition, ASM International, Materials Park, Ohio, 2006

G. Lambating, Instrumentation and Controls, Practical Heat Treating, Course 42, Lesson 10, Materials Engineering Institute, ASM International, 1995
www.asminternational.org

G. Parrish, Carburizing: Microstructures and Properties, ASM International, 1999

L. Samuels, Light Microscopy of Carbon Steels, ASM International, 1999

G. Rowe, Furnace Atmosphere Control, Heat Treating, Vol 4, ASM Handbook, ASM International, 1991

M.S. Stanescu et al., Control of Surface Carbon Content in Heat Treating of Steel, Heat Treating, Vol 4, ASM Handbook, ASM International, 1991

A.S. Tenney III, Temperature Control, Heat Treating, Vol 4, ASM Handbook, ASM International, 1991

Althouse, Andrew D., Carl H. Turnquist, and William A. Bowditch, *Modern Welding, 10th Edition*, Goodheart-Wilcox Co. Inc., 2004.

Bullens, D. K., Steel and Its Heat Treatment, Volume1 – Principles • Processes • Controls, John Wiley & Sons, Inc., 1938

2. Herring, Daniel, “How to Load Parts in Furnace Baskets,” Heat Treating Progress, December 2003

Althouse, Andrew D., Carl H. Turnquist, and William A. Bowditch, *Modern Welding, 10th Edition*, Goodheart-Wilcox Co. Inc., 2004.

Fundamentals of Machine Tools, Training Circular Number 9-524 (TC 9-524), Headquarters, Department of the Army, Washington D.C., 1976

Giachino and Weeks, *Welding Skills, 5th Edition*, American Technical Publishers Inc., Chicago, IL., 1985.

Naval Construction Force Welding Materials Handbook, P-433, Naval Facilities Engineering Command, Department of the Navy, Washington D. C., 1991.

Operator's Manual for Welding Theory and Application, Training Manual 9-237 (TM 9-237), Department of the Army Technical Manual, Headquarters, Department of the Army, Washington D.C., 1976.

J.W. Smith, Types of Heat-Treating Furnaces, Heat Treating, Vol 4, ASM Handbook, ASM International, 1991

G.Y. Lai, Heat-Resistant Materials for Furnace Parts, Trays, and Fixtures, Heat Treating, Vol 4, ASM Handbook, ASM International, 1991



H.N. Oppenheimer, Types of Furnaces and Associated Equipment, Course 42, Lesson 8, Practical Heat Treating, Materials Engineering Institute, ASM International, 1995
 Herring, D. H., Heat Treating Equipment, White Paper, 2003.

Heat Treater’s Guide: Standard Practices and Procedures for Steel, ASM International, 1982.

www.Iran mavad.com

H.N. Oppenheimer, Types of Furnaces and Associated Equipment, Course 42, Lesson 8, Practical Heat Treating, Materials Engineering Institute, ASM International, 1995

G.Y. Lai, Heat-Resistant Materials for Furnace Parts, Trays, and Fixtures, Heat Treating, Vol 4, ASM Handbook, ASM International, 1991

J.L. Dossett, G.M. Baker, T.D. Brown, and D.W. McCurdy, Statistical Process Control of Heat-Treating Operations, Heat Treating, Vo I 4 , ASM Handbook, ASM International, 1991,

R.W. Bohl, Testing and Quality Control of Metals and Alloys, Practical Heat Treating, Course 42, Lesson 13, Materials Engineering Institute, ASM International, 1995

W.E. Dowling and N. Palle, Design for Heat Treatment, Materials Selection and Design, Vol 20, ASM Handbook, ASM International, 1997,

J.L. Dossett, G.M. Baker, T.D. Brown, and D.W. McCurdy, Statistical Process Control of Heat-Treating Operations, Heat Treating, Vo I 4 , ASM Handbook, ASM International, 1991,

R.W. Bohl, Testing and Quality Control of Metals and Alloys, Practical Heat Treating, Course 42, Lesson 13, Materials Engineering Institute, ASM International, 1995

W.E. Dowling and N. Palle, Design for Heat Treatment, Materials Selection and Design, Vol 20, ASM Handbook, ASM International, 1997,

Herring, D. H., It’s Time to Clean Up Our Act!, Industrial Heating, January 2008.

Herring, D. H. and Richard D. Sisson, Jr., Heat Treating Fasteners Part One: Tips of the Trade)

Durkee II, John B., Management of Industrial Cleaning Technology and Processes, Elsevier, 2006, ISBN 0-080-44888-7.

Mr. Joseph P. Schuttert, HyperFlo, LLC (www.hyperflo.com),private correspondence Vander Voort, George, “Microstructure of Ferrous Alloys,” Industrial Heating, January 2001.

Krauss, George, “Steels: Processing, Structure, and Performance,” ASM International, 2005.

Herring. D. H., “The Embrittlement Phenomena in Hardened and Tempered Steel,” Industrial Heating, October 2006.

ASM Handbook, Volume 8, Mechanical Testing and Evaluation,” ASM International, 2000.

Herring, D. H., “Toughness,” Industrial Heating, December 2010.

Page 102 of 105	Federal TVET Agency Author/Copyright	TVET program title- Machining Level -2	Version -1 October 2019
-----------------	---	--	----------------------------



Herring, Daniel H., "Understanding Component Failures Parts 1 & 2," Industrial Heating, July/August 2013

Page 103 of 105	Federal TVET Agency Author/Copyright	TVET program title- Machining Level -2	Version -1
			October 2019



The trainers who developed the learning Guide

No	Name	Qualification	Region	E-mail
1	Wakweya Tolera	A	Oromia	Wakweya.tolera@yahoo.com
2	Mohammed Abdela	A	Dire Dewa	Mahammedabdella49@gmail.com
3	Waliyi Bena	A	Oromia	waliyibena@gmail.com
4	Elias Zemenu	A	Somali	Elijahze26@gmail.com
5	Gurmu Mulatu	A	Adis Ababa	gurmumuulaatuu@gmail.com
6	MulunehNegussie	B	Amhara	Muluneh3000@gmail.com
7	Teshome W/Yuhanis	A	SNNPR	Tesho1921@gmail.com
8	Solomon Aderaw	B	Amhara	solo@19gmail.com



Page 105 of 105	Federal TVET Agency Author/Copyright	Machining Level II	Version -1 October 2019
-----------------	--	--------------------	----------------------------