



Ethiopian TVET-System



INFORMATION TECHNOLOGY SUPPORT SERVICE

Level I

Based on May 2011 Occupational Standards

October, 2019



Module Title: Applying 3S

TTLM Code: ICT ITS1 TTLM03 1019v1

This module includes the following Learning Guides

LG05: Organize Junior Kaizen Promotion Team (KPT)

LG Code: ICT ITS1 M02 L01-LG-05

LG06: Prepare for work

LG Code: ICT ITS1 M02 L02-LG-06

LG07: Sort items

LG Code: ICT ITS1 M02 L03-LG-07

LG08: Set all items in order

LG Code: ICT ITS1 M02 L04-LG-08

LG09: Perform Shine activities

LG Code: ICT ITS1 M02 L05-LG-09

ICT ITS1	Version:01	Page No.2
	Copyright: Ethiopia Federal TVET Agency	



Instruction Sheet	LG05: Organize Junior Kaizen Promotion Team (KPT)
--------------------------	----------------------------------------------------------

This learning guide is developed to provide you the necessary information regarding the following content coverage and topics:

- Basics, principles and stages of KPT.
- Structure of Junior KPT.
- Effective and appropriate contributions to team and objectives.
- Effective and appropriate forms of communications.
- Preparing and using Kaizen Board.

This guide will also assist you to attain the learning outcome stated in the cover page. Specifically, upon completion of this Learning Guide, you will be able to:

- Basics, principles and stages of KPT are identified using appropriate procedures.
- Structure of Junior KPT is established in accordance with the organizational procedures.
- Effective and appropriate contributions are made to complement team activities and objectives using individual skills and competencies.
- Effective and appropriate forms of communications are used and undertaken with KPT members who contribute to know KPT activities and objectives.
- Kaizen Board (Visual Management Board) is prepared and used in harmony with different workplace contexts.

Learning Instructions:

1. Read the specific objectives of this Learning Guide.
2. Follow the instructions described below 3 to 6.
3. Read the information written in the information “Sheet 1, Sheet 2, Sheet 3 and Sheet 4”.
4. Accomplish the “Self-check 1, Self-check t 2, Self-check 3 and Self-check 4” **in page -6, 9, 12 and 14** respectively.
5. If you earned a satisfactory evaluation from the “Self-check” proceed to “Operation Sheet 1, Operation Sheet 2 and Operation Sheet 3” **in page -15**.
6. Do the “LAP test” **in page – 16** (if you are ready).

Information Sheet-1	Basics, principles and stages of KPT.
----------------------------	----------------------------------------------

ICT ITS1	Version:01	Page No.3
	Copyright: Ethiopia Federal TVET Agency	



1.1. Kaizen Basics

Mr. Masaaki Imai is one of the Japanese people who contributed to spreading of the term Kaizen throughout the world. Mr. Imai today serves as the president of a consulting company Cambridge Research Institute. In his book entitled “Kaizen: The Key to Japan’s Competitive Success’ published in 1986, defined Kaizen as “a Japanese business philosophy that assumes our way of life – be it our working life, our social life, or our home life – should focus on continual improvement efforts”. The Oxford English Dictionary also gives the following definition of Kaizen “a Japanese business philosophy of continuous improvement of working practices, personal efficiency, etc.”



Cambridge Research Institute, President.
Kaizen.



Mr. Imai’s 1st book on

Kaizen is a Japanese philosophy for improvement that can be traced to the meaning of the Japanese words ‘Kai’ and ‘Zen’, which translate roughly into: ‘Kai’ - change, alter ‘zen’ - better, right. The above two words combine to mean “change for better” or “Continuous improvement.” Kaizen means improvement, continuous improvement involving everyone in the organization from top management, to managers then to supervisors, and to workers. It is a philosophy of never being satisfied with what was accomplished last week, last year or last time.

Mr. Imai also stated “Kaizen is not just a management technique but a philosophy which instructs how a human should conduct his or her life. Kaizen focuses on how people conduct their work. It shows how management and workers can change their mindset together to improve their productivity”. Not a day should go by without some kind of improvement being made. We have to ask always: how can we do the job better tomorrow, than we are doing it today? Engineers at Japanese plants are often warned, “There will be no progress if you keep on doing things exactly the same way all the time.”

For the U.S., Kaizen’s clear message is “do it better, make it better, improve it even if it isn’t broke, because if we don’t, we can’t compete with those who do.”

The Ethiopian Kaizen Institute developed its own working definition as follows:
"Kaizen is a philosophy of continual, participatory and self-disciplined innovation management having its own integrated systems and problem solving tools, implemented with the highest level of commitments at all levels of owners, leaders and employees through enhancing their absorptive capability step by step aiming at creating new and advanced corporate culture to catch-up and attain world class competitiveness".

1.1 The Origin of Kaizen

ICT ITS1	Version:01	Page No.4
	Copyright: Ethiopia Federal TVET Agency	



Kaizen developed and spread in Japan and later to the world in four phases.

Phase 1 - 1950s (end of world war II): This phase was the absorption of foreign technique by Japan to make improvements and catch-up with the international industrial development. Because at that time products made by Japan were known as low quality and low price in the world market. Japan learned and adapted quality management from Dr. W. E. Deming (a US statistician and consultant) and Dr. J. M. Juran. Then various organizations are established such as the Union of Japanese Scientists and Engineers (JUSE) in 1946 and the Japan Productivity Center (JPC) in 1955, to support the national movement for quality and productivity improvement and to disseminate the American Scientific Quality Control techniques. Many companies developed their own systems of kaizen, including the globally known Toyota Production System (TPS) developed by the Toyota Motor Corporation. These efforts laid a solid foundation for establishing the so-called Japanese production management system. November is decided as quality month and Deming Prize was awarded by JUSE on this month to raise the QC level in Japan. Thus, kaizen was originally a foreign technique which was adopted and adjusted to become a Japanese technique.

Phase 2 - 1970s -180s: This phase was the diffusion of Kaizen among Japanese companies, including small and medium sized companies. This led to a rapid increase in the number of Quality Control Circles (QCC).

Phase 3 - mid 1980s: through Japanese firms abroad and various public organizations Kaizen spread in the world. In 1985 Japanese manufacturing companies shifted their production bases to East Asia where they introduced kaizen philosophy and practices.

Phase 4 – In this phase Kaizen diffused to developing regions in Latin America & Eastern Europe including Africa (mainly in Sub-Saharan Africa). East Asia together with the Japanese government's TICAD IV initiative for promoting trade and investment in Africa an opportunity was provided for Japan to more actively publicize and introduce kaizen in developing regions. Kaizen also spread through Imai's first book- 'Kaizen: The Key to Japan's Competitive Success' published on 1986. Most Japanese enterprises are now endowed with world-leading capability.

JICA (Japan International Cooperation Agency) has also offered assistance for Kaizen to many developing countries. JICA's assistance with Kaizen started in Asian countries like Singapore in 1983 then in Malaysia, Philippines, Thailand, Indonesia and Vietnam. And in Latin America countries like Costa Rica, Chile, Argentina, Paraguay, Brazil and Mexico. In Eastern European Countries like Poland, Hungary, Baltic countries (Estonia, Latvia, Lithuania), Armenia, Bosnia Herzegovina, and Serbia.





Clarification of safety passages plates

Inspection tools in good order with name plates



Visual Control Board

JICA Kaizen assistance in Africa started in Egypt, Tunisia, and then in Ethiopia, Kenya, Zambia, Ghana, Tanzania.

1.2 The Dissemination of Kaizen in Ethiopia

Kaizen was driven to Ethiopia by the strong commitment of the Late Prime Minister H.E. Meles Zenawi. After listening to the Kaizen experience of Egypt and Tunisia at the African Taskforce meeting of the Initiative for Policy Dialogue (IPD) held in Addis Ababa on July 2008, the Prime Minister requested the government of Japan for Kaizen project in Ethiopia. In response to the request a work agreement was signed between JICA and the Government of Ethiopia in June 2009. A pilot project was then started in October 2009 to be completed on May 2011. Basic Kaizen activities were implemented in selected 30 large and medium enterprises located at Addis Ababa.

A Japanese Experts team and Ethiopian Kaizen Unit members are assigned for the implementation of the project. Pairing with the Japanese Experts team, the Ethiopian team who were from Ministry of Industry (MoI) has acquired Kaizen-related technical knowledge and skills through on-the-job training and other training opportunities available in the project activities. As a result, Kaizen has come to be known among policy makers and business managers in Ethiopia and an encouraging improvements of quality, productivity, delivery time, cost etc are achieved. Manual and audiovisual materials were prepared for Kaizen dissemination activities in the country.



The Late PM H.E Meles Zenawi



The Late PM Meles Zenawi receiving Kaizen manual produced by the pilot project, 2011.

Following the achievements of the pilot project, the Ethiopian government has decided to establish a core organization i.e. the Ethiopian Kaizen Institute (EKI) under MoI in 2011

ICT ITS1	Version:01	Page No.6
	Copyright: Ethiopia Federal TVET Agency	



to disseminate Kaizen across the nation. At the request of the government of Ethiopia to government of Japan to extend the support and technical cooperation for institutionalization of the EKI in such areas as organizational development, human resource development, and nationwide dissemination of Kaizen, a second project on “Capacity Building for Dissemination of Quality and Productivity Improvement (Kaizen)” was launched on November 2011 to be carried out for three years until October 2014.

The Ethiopian Kaizen institute is established with various objectives and functions of formulating policies, plans, strategies and programs for Kaizen dissemination; providing trainings; developing authorized and standardized training materials and manuals; conducting consulting services; and establishing mechanisms for nationwide outreach. EKI has designed Ethiopian Kaizen model consisting of five stages: Testing, Institutionalization, Implementation, Sustain and Ownership (TIISO). At each of these stages awareness raising, experiencing best practices and customization are done.

1.3 The Three Pillars of Kaizen

Kaizen is crucial for any sector because factories and organizations of any sector are like living organisms. The healthiest organisms move and change in a flexible manner in accordance with their environment. In the business world, customer needs are always changing, new technologies are continually being developed and generation after generation of new products appear on the market. Sales competition is becoming tougher each year as companies strive to manufacture more sophisticated products at lower cost. The same is true with the service providing industries. In the presence of these challenges, therefore factories or organizations must find new ways to ensure their survival by adapting to the changing business environment. They must move beyond old organizational concepts and customs that no longer apply and must adopt new methods that are appropriate to the new times.

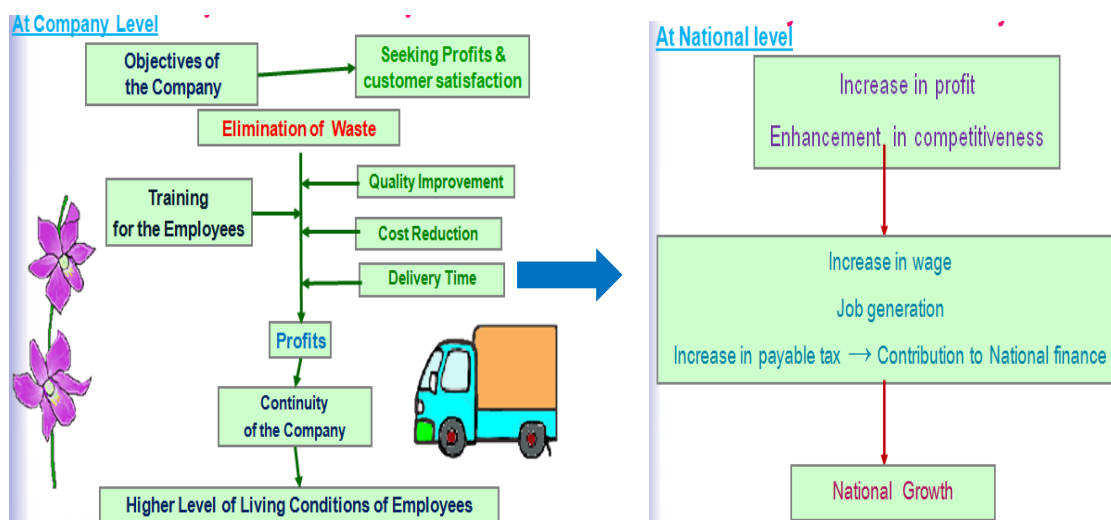

As indicated in the above diagrams, one of the objectives of a company is increasing profits. If sufficient profits are generated, the continuation of a company and the living conditions of its employees also ensured. Quality, cost reduction, and delivery time are the three biggest contributors to the profit increase through elimination of wastes/Muda.

In general Kaizen is indispensable to:

- ✿ Make optimal use of peoples' skills



- ✱ Reduce overall cost
- ✱ Maintain high quality (or improve quality)
- ✱ Reduce or eliminate wastes (MUDA)
- ✱ Improve productivity
- ✱ Improve Safety
- ✱ Shorten lead time & improve delivery time
- ✱ Improve space utilization etc

Masaaki Imai proposed Kaizen as “the unifying thread running through the philosophy, the systems, and problem solving tools developed in Japan over the last 30 years”. The three pillars of Kaizen are:

- 1) As a philosophy
- 2) Kaizen systems
- 3) Kaizen tools

1.3.1 Kaizen as a Philosophy

Kaizen is a philosophy of continuous undertaking by an organization to improve its activities and processes with the goal to always improve Kaizen elements: Productivity, Quality, Cost, Delivery time, Moral, Safety, Environment and Gender equality (PQCDMSEG) so that the organisation can meet full customer satisfaction. Kaizen starts with the recognition that any corporation has problems and it solves these problems by:

- Establishing corporate culture
- Following a customer-driven strategy to increase customer satisfaction.
Management’s role should be to make a constant effort to provide better products at lower prices. Management should devote at least 50 percent of its attention to Kaizen.
- Emphasizing on process or process-oriented way of thinking.
- Supporting and acknowledging people’s process-oriented efforts for improvement rather than evaluating people’s performance on the basis of results.

Kaizen as a philosophy is built-in and run through guiding principles. These guiding principles can be summarized as follows:

- Proactive and spontaneous participation of front-line workers (they are centre of Kaizen activities).
- Focus on the improvements of workplace/Gemba (the foundation of all the improvement efforts). It is a key entry to endless revolving activities of Kaizen.
- Practicing kaizen that lead to a corporate culture.
- Kaizen fosters process as well as result oriented thinking.
- Speak with data - collect, verify and analyse data.
- Put quality first even than cost and delivery.
- Bottom-up approach i.e. integrated total company approach: genuine participation of top management, middle managers and front-line employees in a collaborative working system throughout company organizations
- Continuous and endless activities in revolving cycles of PDCA resulting in significant improvements.
- Top management commitment.
- Learning process and customization
- Customer satisfaction

ICT ITS1	Version:01	Page No.8
	Copyright: Ethiopia Federal TVET Agency	

Kaizen as a management strategy has its characteristics. These are Kaizen has continuity, follows participatory approach, accumulation of small Improvement, applied using small investment and widely applicable.

- **Continuity:** Kaizen is a dynamic activity in revolving cycles of PDCA (Plan, Do, Check and Act). Once a new improvement becomes a new standard, the next cycle is set up to seek further improvement. Kaizen is a continuous challenge towards ever higher-level improvement, cycle by cycle, without an end.

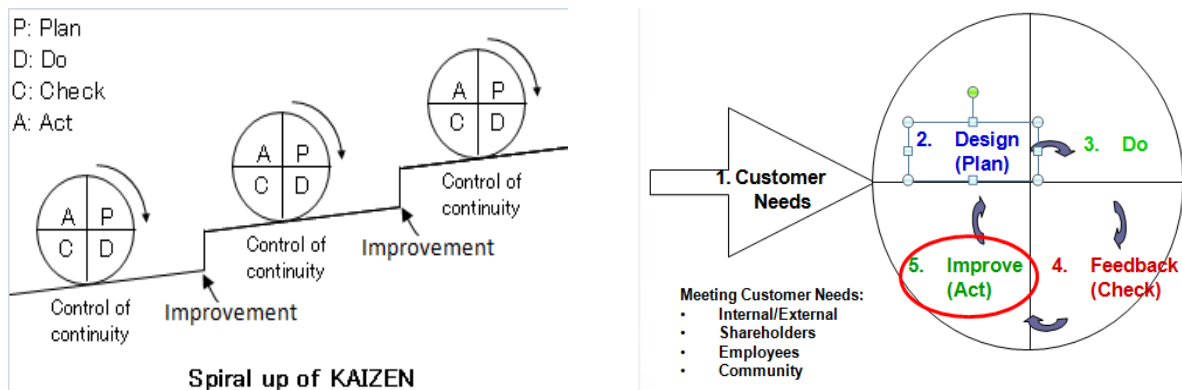

- **Participatory approach:** Kaizen is built in and run with an integrated and company-wide approach through the collaboration of all the levels of the organisation that are top management, middle managers and front-line employees. Commitment, genuine participation and motivation of all the three actors are critical factors. As shown in diagram 1 Kaizen core team is a team of the management bodies of an organization whose duties are to lead and direct all teams established in each department and cross functional teams with members from different departments. Cross functional teams are formed to solve problems that cannot be solved by departments. Diagram 2 shows Kaizen dissemination in an organization by selecting and implementing Kaizen in sample and model work areas and then building on and expanding the success in company-wide scale. For fruitful participation, giving training and education as well as communication is very important. To utilize individual workers ideas suggestion system can be introduced.

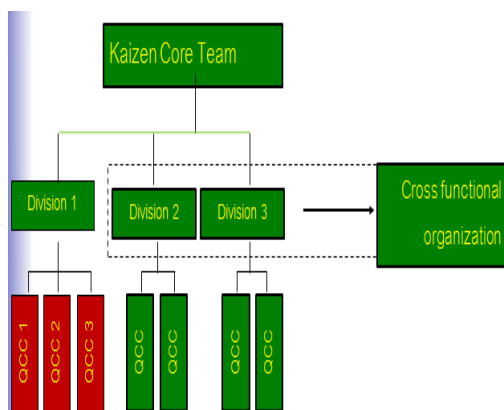

Diagram 1: Core team, cross functional team and dissemination QCC(Quality Control Circles) and Institutionalisation

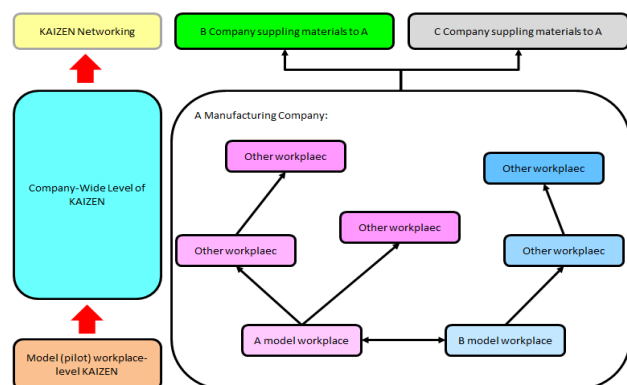

Diagram 2: Kaizen



- **Accumulation of small Improvement:** Japanese people say “accumulation of a small dust builds a mountain”. Significant and greater results can be attained through accumulation of small improvements or by carrying out repeatedly minor or small improvements as opposed to innovation.
- **Needs small investment:** Waste elimination may not require investment or may require little investment through the introduction of basic Kaizen technique such as 5S. To conduct 5S i.e. to sort or separate necessary and unnecessary items , to set or place items in locations suitable for work and to shine or clean: red tags, paint, shelves, racks, display boards and cleaning materials etc. are needed which can be bought with small investment. A company shouldn't have to make large investment to buy machines and make Kaizen/improvements. If machines are used before eliminating wastes from the work area and operations, this will lead to the mechanization of wasteful operations. There will not be a value adding works in the company.
- **Widely Applicable:** Kaizen refers to a philosophy or practices that focus upon continuous improvement in manufacturing activities, business activities, and even life in general, depending on interpretation and usage. It is widely applicable in manufacturing, service, public or non-profit organizations and others. Kaizen techniques are now universally applicable to all sectors.

Requisites of Kaizen: to understand and successfully implement Kaizen the following Kaizen requisites should be fulfilled.

- **Knowledge of Kaizen concepts and techniques** is essential for doing Kaizen activities. Kaizen is easy to understand and should be started from the easy Kaizen techniques such as 5S and QC7 tools.
- **Attitude with positive thinking** is necessary for understanding and implementing Kaizen and Kaizen concept and techniques can also build positive attitude and can bring corporate culture.
- **Involvement of all from top management to front-line workers:** top management with commitment and interest on Kaizen, participation of all workers and establishment and involvement of cross-functional teams are essential for success and continuity of Kaizen.

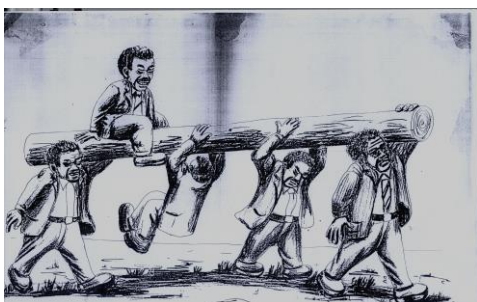

- **Zealous support for Kaizen:** Kaizen needs zealous attention like support for one football team.

ICT ITS1	Version:01	Page No.10
	Copyright: Ethiopia Federal TVET Agency	



- **Education about Kaizen (training):** Kaizen is human-oriented i.e. it is implemented by employees therefore education or training about Kaizen is vital.
- **Never-ending activity:** Kaizen is continuous and practical, aiming always for best improvement through accumulation of small improvements.

1.3.2 Kaizen Systems

Underlying the Kaizen strategy is the recognition that management must seek to satisfy the customer and serve customer needs if it is to stay in business and make a profit. This Kaizen strategy has systems that can be applied to realize planned goals and targets. These systems include:

Toyota Production System

The Toyota Production system sometimes called the *Kanban* system or *Just in time*, attracts great attention in Japan and abroad, because Toyota is one of the few companies which have survived the oil crisis on 1980s and still maintained a high level of profitability. Toyota is well known for its outstanding quality control systems, and worker-suggestion system. The man who pioneered Toyota's unique system, Taiichi Ohno, claims that Toyota system is born out of the need to develop a system for manufacturing small numbers of many different kinds of automobiles which is contrast to the Western practice of producing large numbers of similar vehicles. Ohno also classified the waste incurred in the production process into seven types (listed on next content). To eliminate these wastes, he devised the *just-in-time* and *jidohka* (automation) concepts.

Just-in-time means that the exact number of required units is brought to each successive stage of production at appropriate time. *Kanban* is a signboard or label used as a communication tools in this system. It is attached to each box of parts as they go to the assembly line. *Jidoka* (autonomation) is when machines stop automatically whenever a problem occurs. All machines at Toyota are equipped with automatic stop mechanisms. The worker has to attend at the machine when it has stopped which enables him/her to take charge of many machines at a time, thus greatly improving his productivity.

The Toyota production system is, in a nutshell, a system which makes sure that the required number of parts and components are manufactured and forwarded to the final assembly line so that final assembly does not stop. It is a system that is still undergoing change and improvement every day.

Total Productive Maintenance

Total productive maintenance (TPM) is an innovative Japanese concept which can be traced back to 1951. TPM aims at maximizing equipment effectiveness throughout the entire life of the equipment. TPM can be considered as the medical science of machines. TPM involves everyone in all departments and at all levels; it motivates people for plant maintenance through small-group and voluntary activities, and involves such basic elements as developing a maintenance system, education in basic 5S, problem-solving skills, and activities to achieve zero breakdowns. Top management must design a system that recognizes and rewards everyone's ability and responsibility for TPM. TPM training is conducted with the emphasis on such basics as how the machines work and how to maintain them in the workshop.

ICT ITS1	Version:01	
	Copyright: Ethiopia Federal TVET Agency	Page No.11



The goal of TPM is the total elimination of all losses. Overall Equipment Effectiveness (OEE) allows to quantify the 6 major types of equipment losses. These are:

- 1) *Breakdowns* are times when equipment breaks down due to failure and isn't available when we need it to be.
- 2) *Setup and adjustment losses* occur when we're working to prepare equipment to run a different type of product. (e.g. exchange of dies in injection molding machines, etc.)
- 3) *Idling and minor stoppages* (abnormal operation of sensor, etc.).
- 4) *Reduced speed* (discrepancies between designed and actual speed of equipment)
- 5) *Defects in process and rework* (scrap and quality defects requiring repair). These occur when our machines produce bad parts. These are especially devastating losses since the time the machines spent producing the bad parts is wasted and chances are good that the machine will have to spend additional time reworking the part or producing a new part altogether.
- 6) *Reduced yield* between machine startup and stable production.

Total Quality Control (TQC)

Organized kaizen activities involving everyone in a company- managers and workers- in a totally integrated effort towards improving performance at every level. This improved performance is directed toward satisfying such cross-functional goals as quality, cost, scheduling, manpower development, and new product development. It is assumed that these activities ultimately lead to increased customer satisfaction. It is equivalent to Company-Wide Quality Control (CWQC).

Total Quality Management System

A number of management practices, philosophies and methods to improve the way an organization does business, makes its products, and interacts with its employees and customers. QCC activity functions as an integral part of TQM. TQM was evolved from TQC in the late 80s.

Suggestion system

Suggestion system is an integral part of the established management system, and the number of worker's suggestions is regarded as an important criterion in reviewing the performance of these workers' supervisor. It is a method by which the ideas and suggestions of the employees are communicated upward through the management hierarchy in order to achieve cost savings or improve product quality, workplace efficiency, customer service, or working conditions. Examples range from simply placing suggestion boxes in common areas to implementing formal programs with committees to review ideas and rewards for those that are adopted.

1.3.3 Kaizen Tools

As presented by Masaaki Imai, Kaizen is an umbrella concept that embraces different continuous improvement activities on an organization as shown in the figure *below* . There are a large number of related and often overlapping implementation methods and technical tools that belong to the kaizen Toolkit. Basing on kaizen philosophy and through following kaizen systems, Kaizen tools bring continuous improvement.

ICT ITS1	Version:01	Page No.12
	Copyright: Ethiopia Federal TVET Agency	

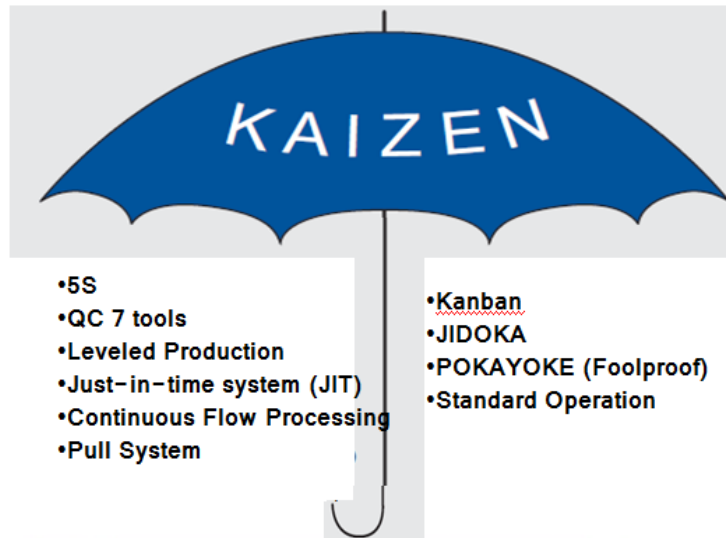
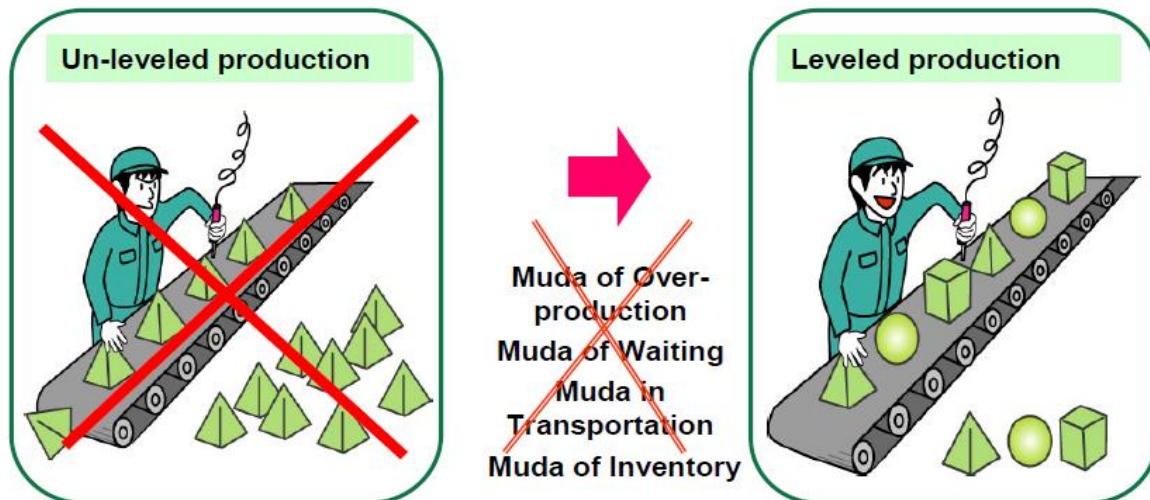

Fig. Some basic Kaizen techniques.

5S is a systematized approach to standardize work environment of an organization so as to create a workplace that is more organized, more efficient, safer, cleaner, and more pleasant to work in, and to maintain it on an on-going basis. It consists of Sort, Set in Order, Shine, Standardize and Sustain.

QC 7 tools are the most frequently used analytical tools for QC activities and Kaizen activities. They are: (1) graphs; (2) check sheets; (3) histogram; (4) control charts; (5) Pareto charts; (6) fish-bone charts (cause-and-effect diagrams); and (7) scatter diagram.

Leveled production means levelling of type and/or volume of items produced at anytime. It is avoiding variance in product types and/or volume.



Just-in-time is a method of production in which a production line produces just what is needed, only when needed, and in exact quantity needed.

Continuous flow processing is a method of production in which products move from one work station to the next piece by piece in succession and in Correct sequence of processing to complete a process.

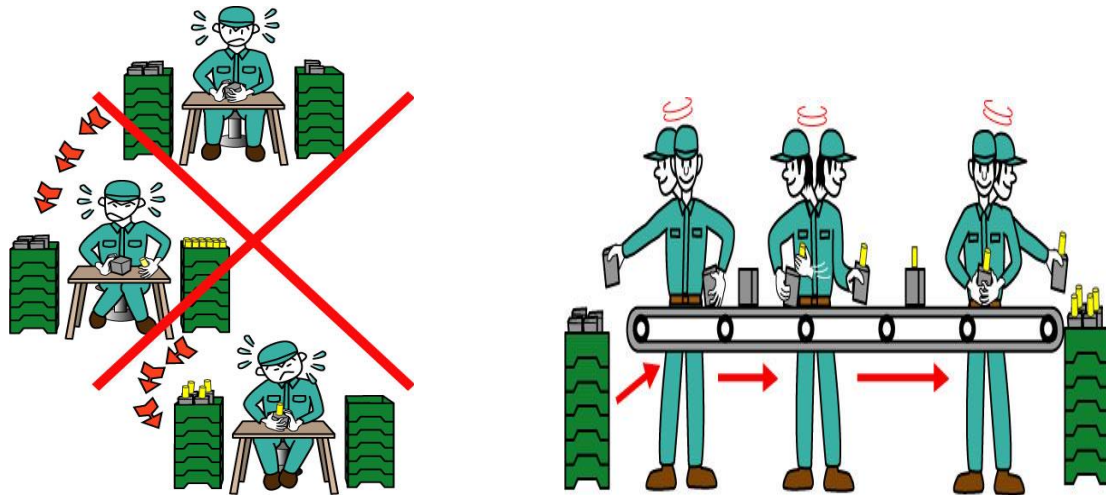

Pull System is when products in the previous process are taken by the workers in the next process when needed and in the amount needed. In the previous process operation, only the amount taken is produced. *Kanban* is used as the communication tool to request parts, semi-products or materials from the upstream process (previous process) in exact quantity & specifications needed.

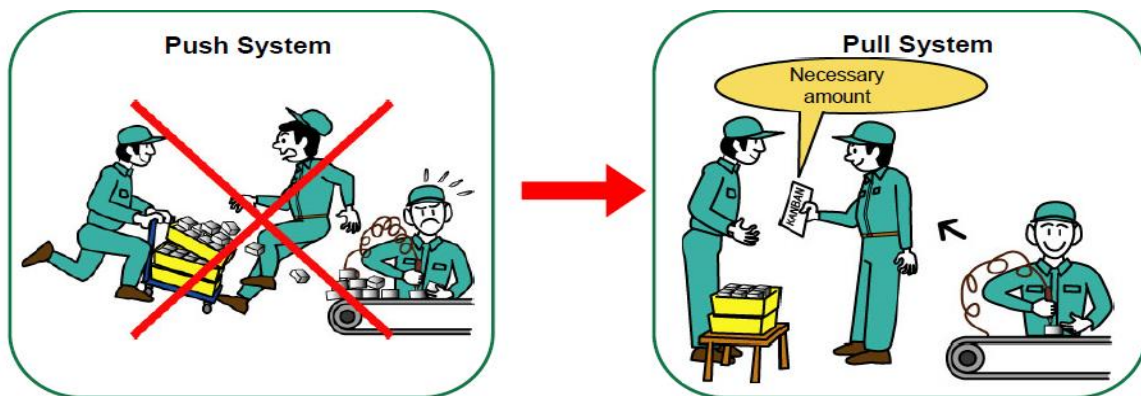

JIDOKA is a systematic approach to prevent defects or abnormalities from passing to the next process. Operation stops automatically by a **programmed machine** at the time of detection of an abnormality or stopped **by the worker** who detected the abnormality.

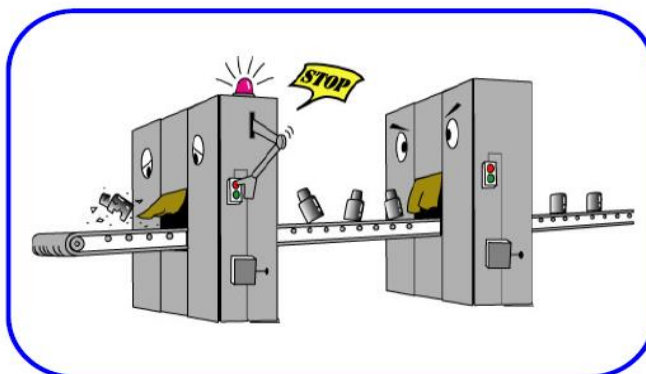
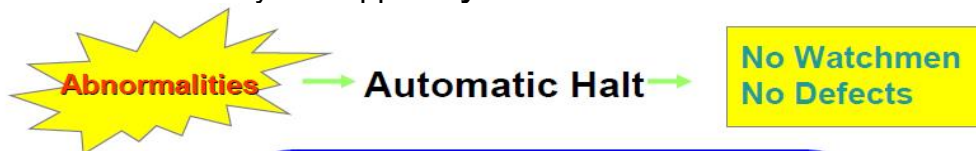

POKAYOKE (Foolproof) means error prevention. It is a method which avoids mistakes and defects from being produced. e.g, only one type of bolt used within a specific workstation to prevent wrong part usage.



Standard operation is an efficient production method/procedure that can be followed by anyone assigned for a task. It helps to clarify the rules for the production method and find out what is wasteful, uneven, and overburdening.

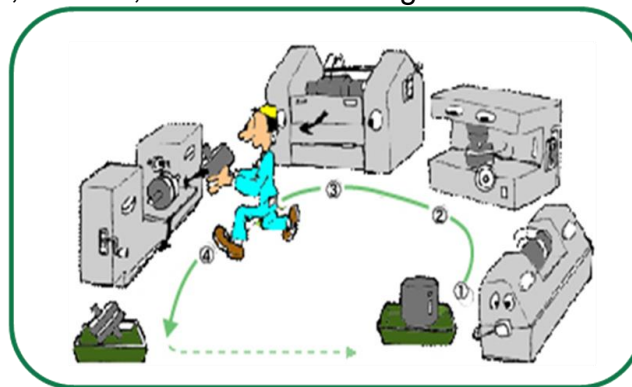

“All I need to do is to follow the same cycle!”

1.4 Kaizen targets or elements

PQCDSMEG are targets of Kaizen activities. PQCDSMEG stands for Productivity, Quality, Cost, Delivery time, Safety, Moral, Environment, and Gender equality (added by EKI). If this eight targets can be achieved, then success of the organization and customer satisfaction are confirmed. QCD refers to the three elements of satisfying customer requirements: Quality, Cost and Delivery.

Productivity: is expressed as the ratio of output to input. A general productivity measure often used in production control is the quantity or value of products produced per unit time. Another commonly used productivity measure is labor productivity, i.e., the quantity or value of products produced per worker per hour.

Quality: means degree of fulfillment of requirements. In a market economy or where competition is prevalent, these requirements are ultimately what the customers’ demand of products or services they want to purchase. In most cases, companies providing the products or services determine the requirements based on their best attempt to meet the customer needs. In other words, quality refers to conformance to specifications and customer requirements. For instance, Product quality requirements relate to the product's shape, appearance, performance, reliability, durability, and so forth. These product requirements are ultimately what the customers want.



In a broader sense, quality refers to the quality of process or work in designing, producing, delivering, and after-servicing the products or services. The foremost concern is with the *quality of people*. The three building blocks of a business are hardware, software, and “human ware.” Only after human ware is squarely in place should the hardware and software aspects of a business be considered. Building quality into people means helping them become Kaizen conscious.

Cost: is monetary value of all the inputs to produce a product. In accounting terms, cost includes cost of labor, cost of materials, and other expenses. The cost items that can be directly attributable to a product manufacturing process is called direct expense, while others are called indirect expense. Total manufacturing cost, or product cost, is the sum of the two. Unit manufacturing cost (unit product cost) is used in the factory level or workplace level cost management, therefore, used often times in KAIZEN activities as well. Cost is one of the three primary targets of improvement in KAIZEN activities along with quality and deliver.

Manufacturing/Service cost = (material + labor + facility + utility + others)cost

The word cost usually refers to cost management, and not cost cutting. Cost management refers to managing various resources properly, and eliminating all sorts of wastes/Muda in such a way that the overall cost goes down.

Delivery time: refers to the timely delivery of the volume of products or services to meet the customer’s needs. On-time product delivery to the customer or adhering to the due date is critical to achieve customer satisfaction together with quality and cost in a competitive market environment.

Moral / Motivation: Morale generally refers to people's confidence, enthusiasm and discipline as a person or as a group. Morale at workplace is therefore employees' confidence, enthusiasm and discipline in terms of the work and goals of the workplace. People have the desire to demonstrate their capability fully, to be recognized, to grow, and to become fulfilled. KAIZEN activities at the workplace with genuine participation of employees provide such opportunities to the employees, and as the result, boost their morale. This is to create a virtuous cycle of KAIZEN's advancement and the employees' growth as individual persons progressing in tandem. In order to achieve such a virtuous cycle, company management should develop and maintain a management principle of trust and empowerment for employees, in which employee participation and their initiatives at the workplace are fully supported; delegation of authority to managers/supervisors is properly done; and training opportunities are provided to employees. And motivation is people's willingness to work on tasks, activities and any other engagements they undertake.

Safety: Kaizen is also used as a methodology for making safety improvements. Safety is the condition of a “steady state” of an organization or place doing what it is supposed to do. In the world of everyday affairs, not all goes as planned. Some entity’s steady state is challenged. This is where security science, which is of more recent date, enters. Drawing from the definition of safety, then: Security is the process or means, physical or human, of delaying, preventing, and otherwise protecting against external or internal, defects, dangers, loss, criminals, and other actions that threaten, hinder or destroy an

ICT ITS1	Version:01	Page No.16
	Copyright: Ethiopia Federal TVET Agency	



organization's "steady state," and deprive it of its intended purpose for being. For instance, home safety may indicate a building's ability to protect against external harm events (such as weather, home invasion, etc.), or may indicate that its internal installations (such as appliances, stairs, etc.) are safe (not dangerous or harmful) for its inhabitants.

Ensuring that a workplace is safe and lively to the satisfaction of the employees working there, and it is also indispensable as corporate activities. In particular, safety is directly related to each worker. The employees are expected to have a strong stance of creating a workplace which is safe and full of vitality. Each year thousands of employees are killed or seriously injured at work. The vast majority of these deaths could be prevented, and the severity of the injuries could be greatly reduced. There are nine key sets of actions that you can take to improve safety in your company.

- Mark emergency exits and put up warning signs
- Provide protective clothing and tools
- Raise safety awareness
- Establish safety standards and regulations
- Set up safety committees and patrols
- Ensure facilities and equipment are safe
- Keep accident records
- Set safety targets
- Be prepared to deal with disasters

A safe workplace is a place with decreased in negligent errors, decreased or zero accidents, reduction of fatigue, comfortable environment, proper arrangement, clean etc.

Environment: The environment has many resources essential for life. These resources must be used wisely for generations to continue. Such resources include air, water, light, land/space etc. which should be utilized efficiently. Wastes that occur on the environment should be reduced by recycling as much as possible. Applying Kaizen also helps to make efficient use of the environment and to conserve it. Hence, environment should be one of the targets of Kaizen..

Gender equality: Gender can refer to the unconsciously constructed roles of men and women, as well as their mutual relationships, based on such factors as culture, tradition, and customs. Deep-rooted gender inequality, especially in developing nations, frequently places women in a disadvantaged position with regard to education, healthcare, labor, and other aspects of society. The promotion of gender equality and empowerment of women is a priority of the Millennium Development Goals and will remain an important part of the development agenda. Kaizen can convey this gender equality by changing the attitude of people. Hence bringing gender equality should be one of the targets of Kaizen. Gender should be considered in conducting any activities.

1.5 Wastes/‘Muda’

1.5.1 Definition of Waste/ Muda

Wastes or Muda are activities which use resources, time or cost without adding value. Value-added means those activities that change raw material into value for the customer. Muda is a Japanese word meaning wasteful activity. It is anything unnecessary in operation. It increases production cost and affects the quality of the product and also delivery time. Reducing or eliminating Muda is, of course, one of the fundamental objectives of any quality-oriented person.

ICT ITS1	Version:01	Page No.17
	Copyright: Ethiopia Federal TVET Agency	

1.5.2 Muda identified by TOYOTA company

Seven main types of wastes were identified by Taichi Ohno as a part of the Toyota Production System. However, this list has been modified and expanded by various practitioners. Every waste you will come across in any organization or even in day-to-day life will fall into one of these categories. Such as: Muda of overproduction, inventory, motion, transportation, waiting, over-processing and defecting making.

Over production: Muda of over-production means to produce things more than necessary in terms of type, time, and volume. It is called “the worst kind of Muda” since it hides all the other wastes.



Inventory: Muda of inventory includes a stock of raw materials, work in process and final products. It needs stock space and excess transportation.

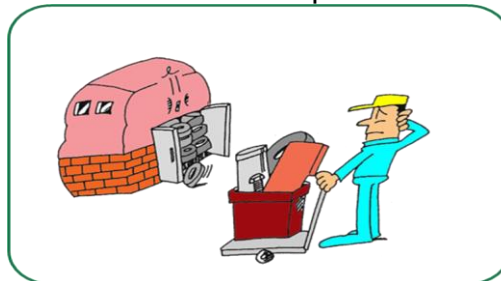

Motion: Muda of Motion are non-value adding movements or more than necessary movements of workers, equipment, and machines, such as looking for goods, bending, stretching, walking, lifting, and reaching etc.

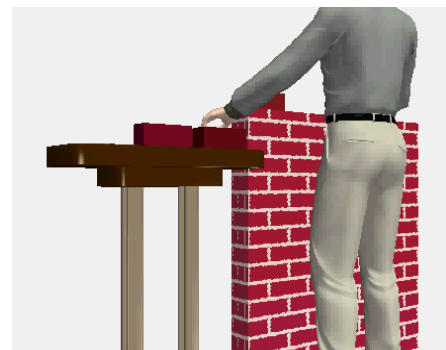

Before

After

Transportation: Muda of transportation is transportation of materials over a long distance or re-piling up. This Muda is usually difficult to be totally eliminated but reducing is possible.

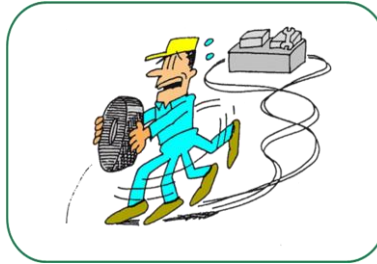

Waiting: Muda of waiting is when workers, machines or parts wait for an upstream process to deliver, for a machine to finish processing, and for parts or materials to come.

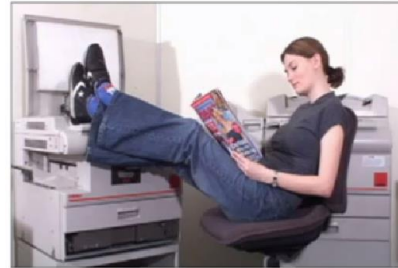
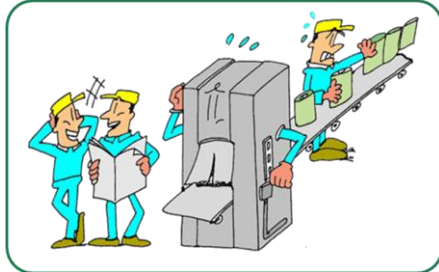

Over-processing: This Muda consists of unnecessary processing and operations. It is processing beyond the standard required by the customer. Eg. relying on inspections rather than designing the process to eliminate problems.

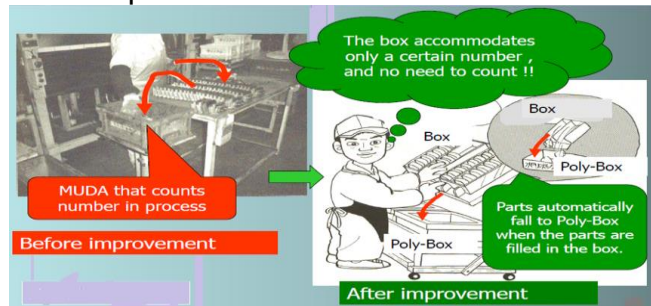
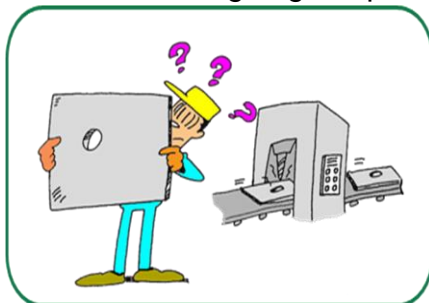

Defect making: This Muda of defect making includes defects, inspections for defects in-process, reworks, and resource loss.



Self-Check 1	Written Test
---------------------	---------------------



Directions: Answer all the questions listed below. Use the Answer sheet provided in the next page:

1. Define the word Kaizen? (3 points)
2. Write the origin of Kaizen and its emergence and dissemination in Ethiopia? (6 points)
3. What are the three pillars of Kaizen? (3 points)
4. What are the characteristics of Kaizen? (5 points)
5. What are the principles and benefits of Kaizen? (6 points)
6. List the elements of Kaizen. (8 points)
7. What does waste / Muda mean? (2 points)
8. What are the seven types of Muda identified in Toyota Production System? (7 points)

Note: Satisfactory rating - 20 points Unsatisfactory - below 20 points
You can ask your trainer for the copy of the correct answers.

Answer Sheet

Score = _____

Rating: _____

Name: _____

Date: _____

1. _____

ICT ITS1	Version:01	Page No.20
	Copyright: Ethiopia Federal TVET Agency	



1. _____

2. _____

3. _____

4. _____

5. _____

6. _____

7. _____



8.

Information Sheet 2	5S Basics
----------------------------	------------------

2. 5S basics

2.1 Definition of 5S

5S is a systematized approach to standardize work environment of an organization so as to create a workplace that is more organized, more efficient, safer, cleaner, and more pleasant to work in, and to maintain it on an on-going basis. The pillars of 5S are all Japanese words beginning with the letter S. Since their adoption within Western implementations of lean, various anglicized versions of the terms have been adopted by different writers and educators. 5S consists of: (1) Seiri = Sort; (2) Seiton = Set in Order; (3) Seiso = Shine; (4) Seiketsu = Standardize; (5) Shitsuke = Sustain.

5S represents a starting point of Kaizen, i.e., by establishing and maintaining standardization of work environment, it provides the basis for future improvements in the operations of the organization. These five pillars represent a starting point for any company that seeks to be recognized as a responsible manufacturer eligible for world-class status. On one hand, 5S is only possible with the participation of the workplace employees. On the other hand, practicing 5S on an ongoing basis results higher motivation and more participatory attitudes at the workplace, which become the common ground for all Kaizen activities. 5S is practiced in many countries and translated in many languages as shown below.

ICT ITS1	Version:01	Page No.22
	Copyright: Ethiopia Federal TVET Agency	

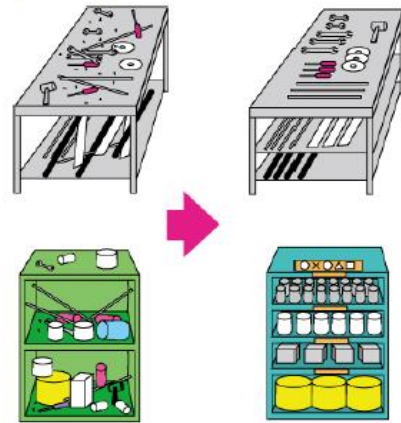

Shine: is the 3rd of the five components of 5S. It means cleaning equipment, facilities and floor space in the workplace, and ensure that they are in good operating condition.



Standardize: is the 4th pillar of 5S. Standardize means maintain organized and clean workplaces by making Sort, Set in Order, and Shine activities integrated into everyone's regular work.

Sustain: is the 5th of the five components of 5S. Sustain means making a self-disciplined habit of maintaining procedures, rules and arrangements of the organisation.

Summary of 5S

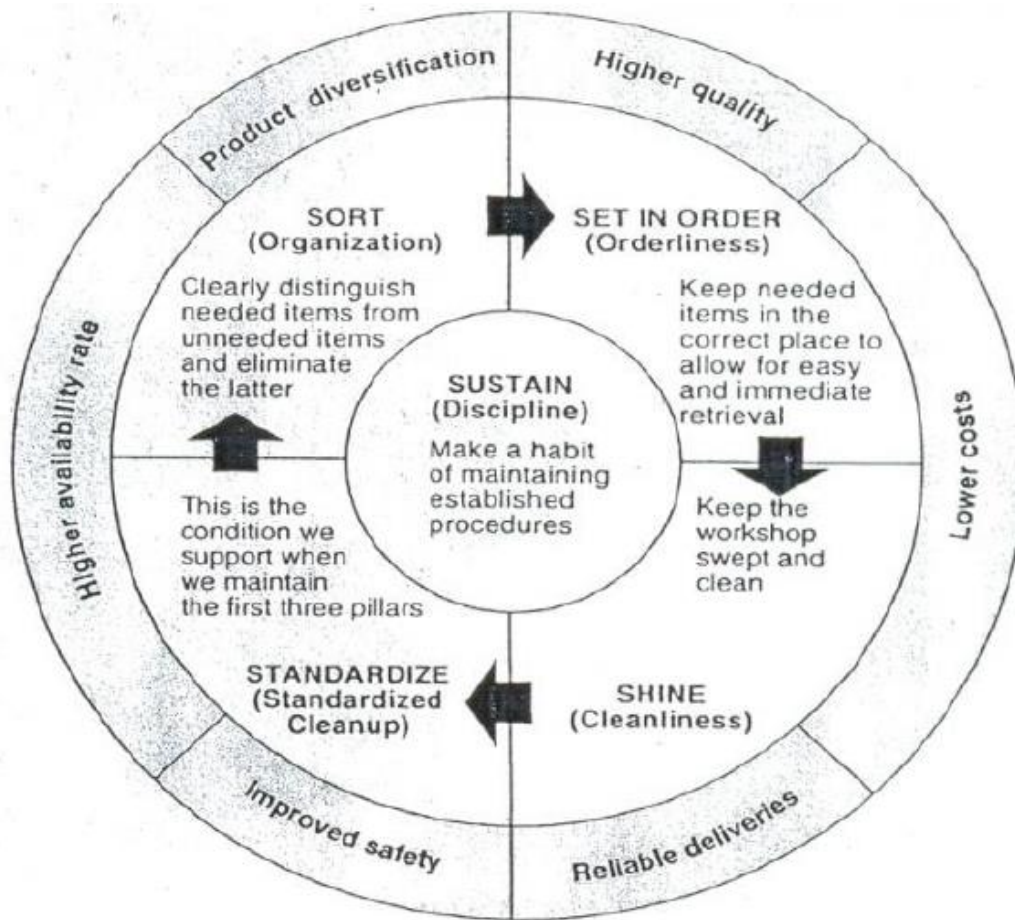

2.3 Benefits of 5S

The 5S system sounds so simple that people often dismiss its importance. However the fact remains that 5S:

- ◆ Makes your workplace safer, cleaner and more pleasant place to work.
- ◆ Makes your job more satisfying.
- ◆ Eliminates overburdens and disappointments.
- ◆ Makes it easier to communicate with everyone you work with.
- ◆ Gives you an opportunity to give creative input how your work place should be.
- ◆ Decreases and makes defects zero that brings higher quality
- ◆ Eliminates waste that reduces cost
- ◆ Avoids delays and bring reliable delivery
- ◆ Increases safety by decreasing accidents
- ◆ Increases productivity by decreasing breakdown
- ◆ Reduces complaint and brings greater confidence and trust

Before

After



2.4 Stages of 5S implementation

The three stages of implementing 5S are:

- Planning
- Implementation
- Sustaining

2.4.1 Planning

Steps for planning include:

1. Form Kaizen Team organizational structure
2. Recognize current condition
3. Deciding activity range
4. Goal setting
5. Planning stage
6. Budgeting
7. Kick-off

1. Kaizen Team Organizational Structure

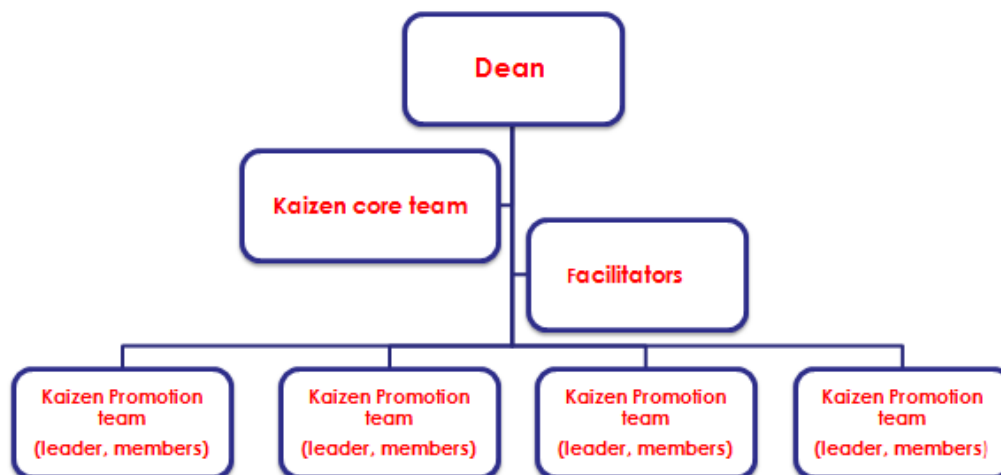

The management body or Kaizen core team with a structure similar to this diagram provides guidance and direction on 5S and company-wide Kaizen activities. Prepare over all 5S or all Kaizen implementation plan, follow up 5S or Kaizen activities, perform any other 5S or Kaizen related activities, organize training etc.



Duties of facilitators is to follow up the activities of KPT's activities, collect information about the KPTs and report to the core team, document plans, reports and results, consult KPTs, distributes all Kaizen formats to the KPTs, assist KPTs' activities related to kaizen, etc.

2. Recognition of current condition

Purpose : Recognize the current condition of workplace and collect information required to identify problems, and set the direction of activity and goals.

Method : 5S Checklist

Photography

Procedure : kaizen promotion office gives instructions

ICT ITS1	Version:01	Page No.27
	Copyright: Ethiopia Federal TVET Agency	



5S checklist

	A	B	Evaluation items	Evaluation po	Remarks about problems
Seiri	<input type="radio"/>		1) Necessary things and unnecessary things can be identified easily.		
	<input type="radio"/>		2) Unnecessary things are discarded, or clarified in time limit for handling.		
	<input type="radio"/>		3) Quantity of each thing is kept as specified.		
	<input type="radio"/>		4) Bulletins and control sheets are replaced with updates.		
			Subtotal		
Seiton	<input type="radio"/>		5) Things are located at each given place.		
	<input type="radio"/>		6) Fixed positions of things are clarified by signboard, delineating, etc.		
	<input type="radio"/>		7) Things are positioned so as to facilitate first-in first-out system.		
	<input type="radio"/>		8) Small improvement realizes easy transfer of things into and from each given place.		
		Subtotal			
Seiso	<input type="radio"/>		9) There are no stain, trash, dust, etc. (facilities, floor, building, lighting, etc.)		
	<input type="radio"/>		10) Upstream solutions are provided against stain, trash, dust, etc.		
	<input type="radio"/>		11) Voluntary inspection of facilities is conducted.		
	<input type="radio"/>		12) Processes, aisles, etc. are delineated with paint colors, etc. so that cleaning area can be easily identified.		
	<input type="radio"/>		13) There are no stain/separation/unevenness/cracks in painted/delineated part on the floor.		
	<input type="radio"/>		14) There are no obstacles on aisles. (carts, pallets, parts, etc.)		
	<input type="radio"/>		15) Cleaning is facilitated with creative efforts.		
		Subtotal			
Seiketsu	<input type="radio"/>		18) Judgment criteria for necessary/unnecessary things are specified.		Items to evaluate the system of 3S (Red Tag Operation, Signboard Operation, and Tidy-it-Up Operation)
	<input type="radio"/>		17) Judgment criteria for disposing unnecessary things are specified.		
	<input type="radio"/>		18) Quantities of necessary things are specified.		
	<input type="radio"/>		19) Fixed positions of necessary things are specified by signboards, layout chart, etc.		
	<input type="radio"/>		20) Heights of racks, etc. are specified.		
	<input type="radio"/>		21) Method/procedure/responsible person/time frame of cleaning are specified.		
	<input type="radio"/>		22) Contents/procedure/responsible person/time frame of voluntary facility inspection are specified.		
	<input type="radio"/>		23) Workers keep neat appearance and have no stain on their clothes, etc.		
	<input type="radio"/>		24) Progress/normality/abnormality in 3S (Seiri, Seiton, Seiso) can be easily identified.		
	<input type="radio"/>		25) Comfortable worksite is maintained through repeated 3S activity.		
		Subtotal			
Shitsuke	<input type="radio"/>		26) Annual policy for 5S activity is set.		
	<input type="radio"/>		27) Annual basic plan for 5S activity is set.		
	<input type="radio"/>		28) 5S activity plan is set for each worksite.		
	<input type="radio"/>		29) Awareness campaign, education, events, and patrols are included in activity plan.		
	<input type="radio"/>		30) 5S evaluation sheet is specially prepared for each worksite.		
	<input type="radio"/>		31) Supervisor prepares "Shitsuke Evaluation Sheet" for workers.		
	<input type="radio"/>		32) Supervisor repeatedly instructs workers on their weak points in Shitsuke.		
	<input type="radio"/>		33) Patrols by the person in each duty position are provided.		
	<input type="radio"/>		34) Responsible persons for patrols properly give advices and take actions.		
	<input type="radio"/>		35) Activity bulletin board is efficiently utilized for timely notice and understandability.		
	<input type="radio"/>		36) Bottom-up activities such as small improvements are invigorated.		
		Subtotal			
			Total	7/105	
			Achievement rate	%	

A: Evaluation of appearance

B: Evaluation of system completion

<Evaluation criteria>

Grade the results of each activity in each evaluation item on a scale of zero to three as follows:

3 points	85% or more
2 points	60% or more but less than 85%
1 point	30% or more but less than 60%
0 point	Less than 30%

Photography

(1) Fixed-point Observation Type

Fix the location of the camera and do photo shoots at the same place both before and after KAIZEN.

Before KAIZEN



After KAIZEN



(2) Random Type



3. Decide Activity range



Decide 5S promotion blocks

Sample

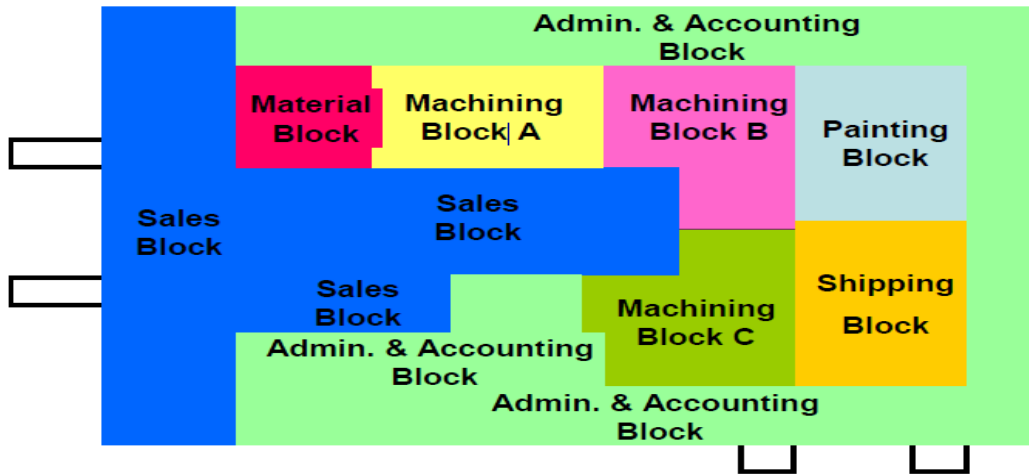

4. Goal setting

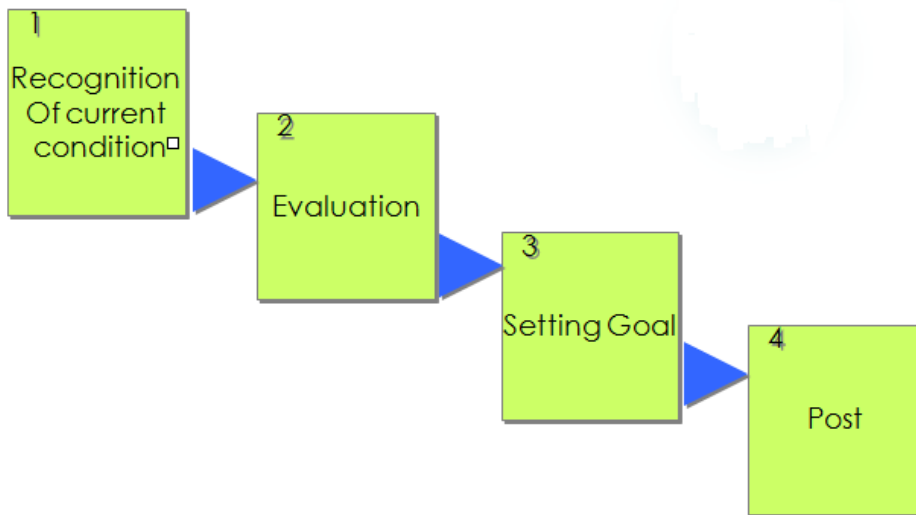



5. Planning

1) Overall promotion plan

The following sample formats can be used to prepare a plan for 5S implementation.

Sample 1

		Date of issue: Issued by 5S Committee																															
Overall Plan for 5S Promotion																																	
Item	Period	1st month				2nd month				3rd month				4th month				5th month				6th month				Progress (%)							
		1w	2w	3w	4w	1w	2w	3w	4w	1w	2w	3w	4w	1w	2w	3w	4w	1w	2w	3w	4w	1w	2w	3w	4w	25	50	75	##				
Basic plan		Preparation								Sort								Set-in-Order								<input type="checkbox"/>	<input type="checkbox"/>	<input type="checkbox"/>	<input type="checkbox"/>				
																		Shine								<input type="checkbox"/>	<input type="checkbox"/>	<input type="checkbox"/>	<input type="checkbox"/>				
Preparing necessary tools																		Standardise								<input type="checkbox"/>	<input type="checkbox"/>	<input type="checkbox"/>	<input type="checkbox"/>				
										Sustain																<input type="checkbox"/>	<input type="checkbox"/>	<input type="checkbox"/>	<input type="checkbox"/>				
Preparing necessary tools																										The tools common to the activities can be prepared in advance.				<input type="checkbox"/>	<input type="checkbox"/>	<input type="checkbox"/>	<input type="checkbox"/>
Preparing textbook for 5S education																										The tools common to the activities can be prepared in advance.				<input type="checkbox"/>	<input type="checkbox"/>	<input type="checkbox"/>	<input type="checkbox"/>
Providing 5S introductory education																										Provide comprehensive 5S education.				<input type="checkbox"/>			
Providing 5S education																										Provide 5S education prior to the start of each 5S activity.							
Photo-shooting																										Take photographs before and after each activity.							
																										Achievement reviews will be conducted in the later term of each 5S activity to choose the best 5S activity results.							

Sample 2

5S Promotion Block Plan by Machining Group																												
					1 month				2 months				3 months				4 months				5 months				6 months			
					1w	2w	3w	4w	1w	2w	3w	4w	1w	2w	3w	4w	1w	2w	3w	4w	1w	2w	3w	4w	1w	2w	3w	4w
Basic plan					Preparation								Seiri								Seiton							
																					Seiketsu				Seiko			
No.	Block	5S	Group	Plan																								
1	M-1	Seiri	A	Plan																								
		Result																										
		Plan																										
2	M-2	Seiton	B	Plan																								
		Result																										
		Plan																										
3	M-3	Seiko	C	Plan																								
		Result																										
		Plan																										
4	M-4	Seiri	D	Plan																								
		Result																										
		Plan																										



2) Setup of activity time

The following table shows example of activity time plan for the 3rd component of 5S i.e. shine.

Type of cleaning	Time	Frequency (timing)
Daily cleaning	5 – 10 min.	Minor operation before/after working hour at each shop
Weekly cleaning	15 – 30 min.	Weekend
Monthly cleaning	30 – 60 min.	End of month
Big cleaning days	2 – 4 hrs.	Before national holidays
Location which is not easy to clean	1 – 2 days	In case of necessity for assistance request to other division

3) Training plan

A training plan is prepared to conduct training on 5S and other Kaizen techniques.



6. Budgeting

It is necessary to prepare a budget for 5S activity because it costs money although it needs small. Budget to buy signboards, labels, paint, etc.





7. Kick-off (Declare 5S implementation)

Inform all employees of kick-off

Assemble all employees



Explain the activity

Declare the policy

2.4.2 Implementation

There are procedures for implementation of each of the pillars of 5S that will be explained in the following contents. Four factors are important for successful 5S implementation. These are:

- Continued commitment and support by top management.
- 5S starts with education and training.
- There are no observers in 5S, everyone participates.
- Repeat the 5S cycle in order to achieve a higher standard.

2.4.3 Sustaining stage

Different sustaining techniques for 5S, that will be described in the following sections, are used at this stage. This stage means performing the activities repeatedly and patiently in order to sustain 5S activity. Success of 5S depends on supervisor's ability to sustain the gains acquired from 5S activity.

ICT ITS1	Version:01	Page No.33
	Copyright: Ethiopia Federal TVET Agency	



Self-Check 2	Written Test
---------------------	---------------------

Instructions: Answer all the questions listed below. Write your answers in the sheet provided in the next page.

1. What are the 5S? (5 points)
2. What are the benefits of 5S? (5 points)
3. What are the three stages of 5S implementation? (3 points)
4. What are the steps for 5S planning? (7 points)
5. Name two methods to recognize or collect data about the current condition of a work place. (2 points)

Note: Satisfactory rating - 11 points Unsatisfactory - below 11 points
You can ask you teacher for the copy of the correct answers.

Answer Sheet

Score = _____

Rating: _____

Name: _____

Date: _____

ICT ITS1	Version:01	Page No.34
	Copyright: Ethiopia Federal TVET Agency	



1. _____

2. _____

3. _____

4. _____

5. _____

3. Junior Kaizen Promotion Team (KPT)

3.1 Basics of KPT

The QCC method is a Japanese-made institutional development tool by which employees continuously strive for improvement in their work. It enhances people's problem-solving skills as a leading management policy in all types of organization. QC Circles are small groups consisting of front-line employees who continually and collectively find a problem and discuss on alternative remedies to control and improve the quality of their work, products and services.

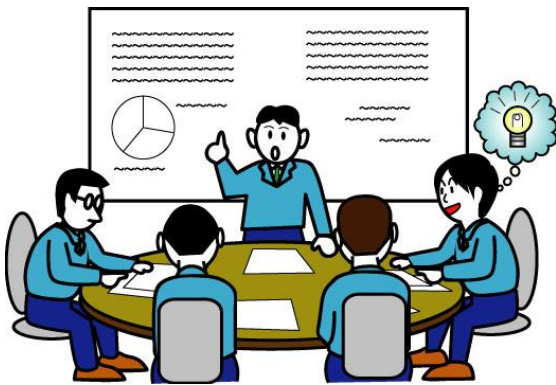

Packing section workers as members of QCC

QCC are formed by a small group between three and ten members who do the same or similar work, voluntarily meeting together regularly for about an hour per week in paid time, usually under the leadership of their own supervisor, and trained to identify, analyze, and solve some of the problems in their work, presenting solutions to management, and where possible, implementing the solutions themselves.

QCCs solve problems autonomously related to workplace such as problems of quality, cost, morale, safety etc. QCCs use several kaizen tools like QC 7 tools (Pareto diagram, Fishbone diagram etc), 5S, Brainstorming, Why-Why Approach, 5W1H etc. Activities of QC Circle are to learn through QC Circle, to manage the work place (workplace rules, standards, 5s...) and solve problems at the work places.

3.2 Aims and Benefits of KPT

- To develop members capabilities.
- To make the workplace more pleasant, vital and satisfying.
- To improve customer satisfaction and contribute to society.
- To create good workers relationship or team spirit through close discussion.
- To develop recognition of importance of work and raise responsibility.
- To establish discipline in workplace and do proper work by reducing mistakes.

3.3 The Principles of KPT

- ✓ Every job is capable of being improved.
- ✓ People do not resist change, they resist being externally changed.
- ✓ Every employee is capable of attaining excellence in his work & the basic ability to improve the job.



- ✓ People like to improve their job and derive satisfaction out of it provided they are involved through human touch, recognition & reward.
- ✓ People like to participate in groups and crave for attention.
- ✓ People have integrity and can be highly creative.
- ✓ A man who does the job knows best about the job at least they know the problems of the job.

3.4 The structure and role of the components of KPT

QCC/KPT structure is governed by unique conditions and eventually, integrated and the concept woven in the fabric of company's total operations as way of life.

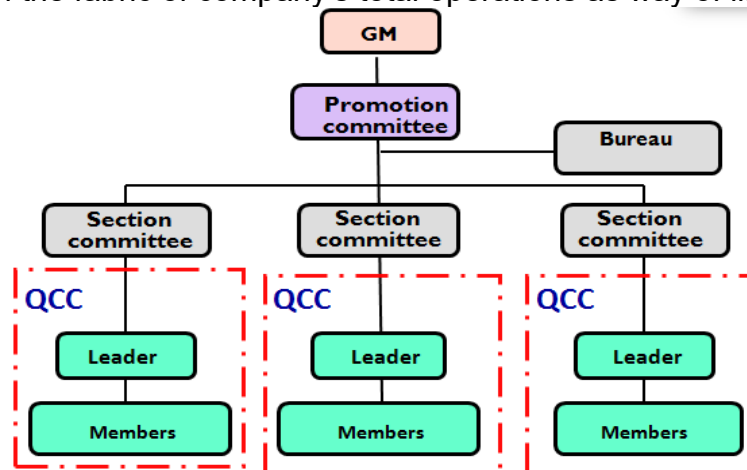

Role of Promotion committees/Kaizen Core Team

- Set clear policy and goal for QCC/KPT program in the company.
- Establish operational guidelines & plans (master plan, plan on how to monitor, evaluate & recognize the exemplary performance of QCC leaders, members)
- Follow the condition of QCC.
- Give guidance, support, and cooperate actively.
- Coordination of QCC activities in the company.
- Formulate a budget for the program and identify sources of funds.
- Define qualifications and functions of facilitators (section committees).
- Evaluate the overall status of the QC Circle program, including training, rewards and recognition, promotional activities at least once a year using criteria and give advice as needed.
- Formulate corrective and preventive actions based on findings in the evaluation.

Role of Section committees/ facilitators

- Provide active support to the QCC & motivate QCC leaders & members.
- Organizes training courses & programs for new QCC.
- Organize QCC presentations.
- Coordinate and ensure availability of facilities to all QCC.
- Act as a counsellor to Promotion committee and QCC leaders.
- It implements the policies and plans formulated by the Promotion Committee.
- It handles all paperwork and maintains records like the QC Circle registry, minutes of meetings, and QC Circle cases.
- It organizes promotional activities like competitions and visits to other companies with QC Circles.
- Each department selects one to three facilitators, depending on the size of the company.



- In the beginning, one facilitator is usually assigned to three QC Circles.
- The QC Circle leaders call on the facilitator when they need support during meetings.

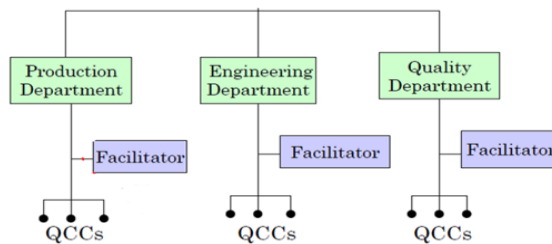

Role of Leader

- Conducting QC Circle meetings & direct activities of QC circle.
- Make clear the purpose of the QC circle's activities.
- Perform as a member in the QC circle activities.
- Maintain good atmosphere in which all members can express their opinions.
- Establish annual activity plan.
- Encouraging members
- Train next leader.
- Participating in industry-wide conventions.
- Studying about QC Circle activities and disseminating the knowledge.
- Seeking advise and support from the QCC Office on behalf of its members
- Manage QC circle activities with appropriately assigning roles to all the members.



Member's role

- Follow the workplace rule and discipline.
- Members listen to each other at all times.
- Participate and speak actively in QC Circle meetings.
- Perform and be responsible to assigned activities.
- Cooperate with other members.
- Arrive at meetings on time.



3.5 Stages of KPT

The development of KPT in Ethiopia by EKI follows four stages of Kaizen implementation junior to medium, high level and lead QCCs/KPTs.

3.5.1 Junior KPT

Junior KPT implement the first level Kaizen which consists of understanding basics of Kaizen, organizing Kaizen Promotion Teams (KPT) and introducing simple Kaizen technical tools (5S, waste/Muda elimination tools). The KPT at this stage develop their Kaizen knowledge, skill and attitude and become able to create an organized and pleasant work place.

3.5.2 Middle/Medium KPT

Medium level KPT implement the second Level Kaizen that includes some advanced Kaizen tools and systems such as Total Quality Control (CWQC), preparing Standard

ICT ITS1	Version:01	Page No.38
	Copyright: Ethiopia Federal TVET Agency	



Operation Procedures (SOP), using Basic Industrial Engineering techniques, Quality Control Tools (7QC Tools) and QC Story line. The KPT at this stage will develop their statistical, analytical and technical Kaizen knowledge and can solve work related problems autonomously.

3.5.3 Higher KPT

The more advanced third Kaizen level is implemented by High level KPTs that consists of having the understanding of Kaizen knowledge related to Toyota Production System, Total Productive maintenance, Total Quality Management, Value Engineering and/or Value Stream Mapping, Industrial Engineering tools, policy deployment and more complex analytical tools and skills.

3.5.4 Lead KPT

Lead KPT are most developed KPT which can implement the fourth and highest level of Kaizen. This KPT can develop advanced management system, principles, models and innovations based on accumulated experiences and best practices.

Quality Circle in a Nutshell

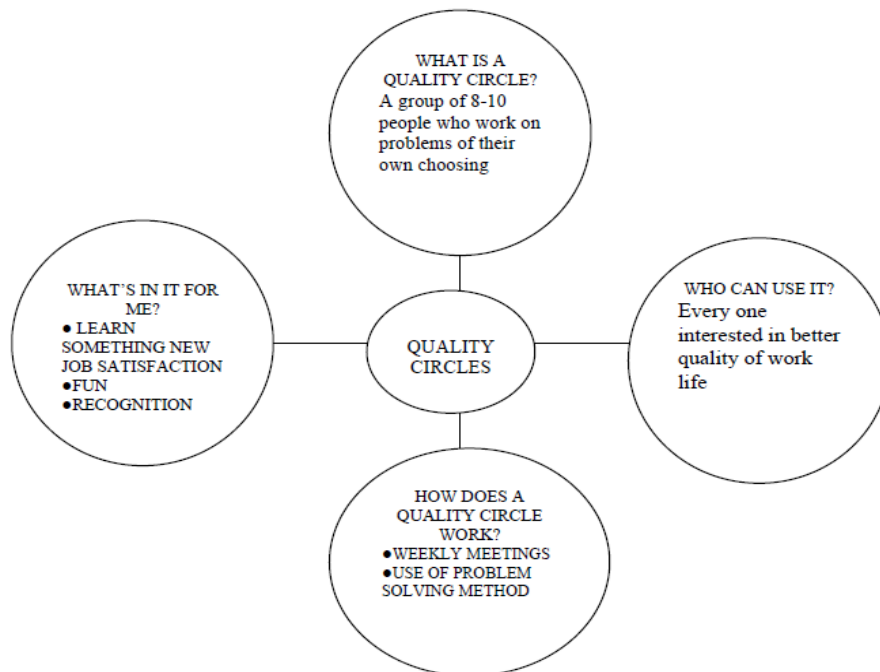



3.6 Establish Junior KPT

3.6.1 QC Circle Introduction Process

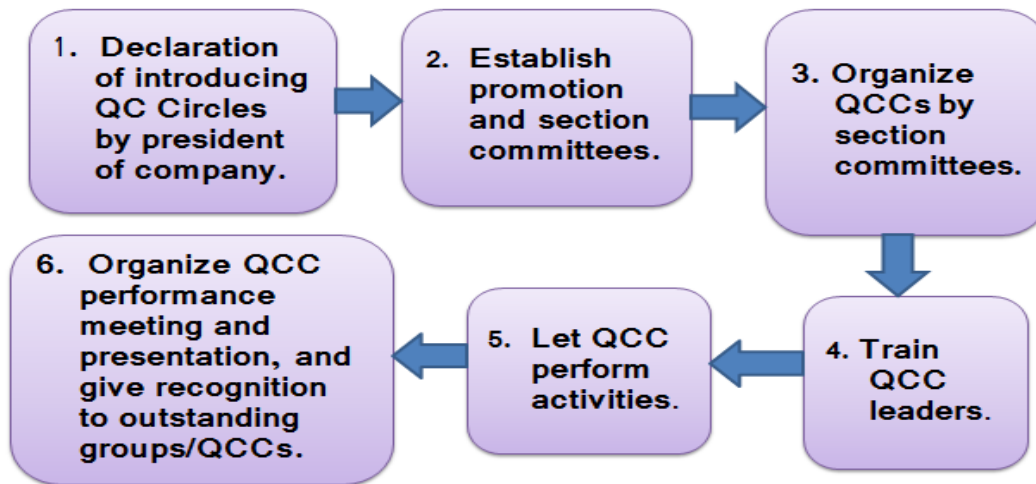

3.6.2 Implementation - Launch of a Pilot Circle

QCC program are tried on a small scale for prior experience. First-line supervisors start on a voluntary basis so as to encourage their subordinates too. The implementation stage consists of eight steps:

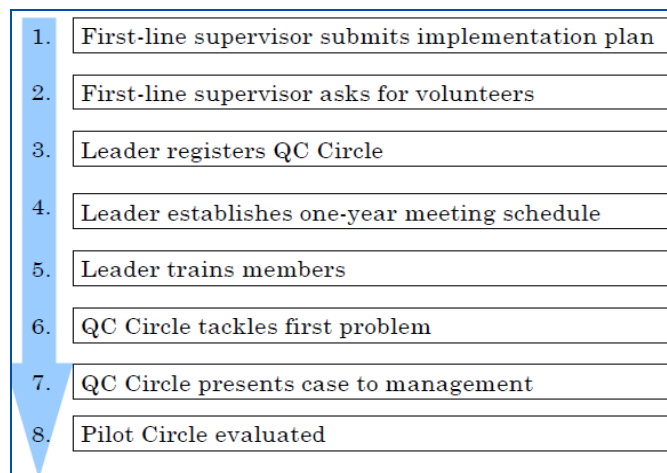

3.6.3 Sustaining QC Circle Activities

Implementation of a Company-wide QCC Program based on pilot experience, more Circles are organized depending on Steering Committee plans following the same training procedures.

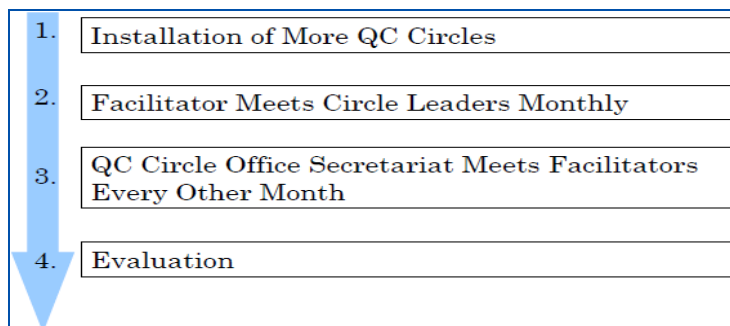

3.7 Method of communication in a team



Teamwork can provide a real opportunity for people to work together to achieve improvement. People who work on their own are often unfamiliar with the work that is done even by people who work quite near to them: as a result, they are unaware of the consequences of poor quality in the work they themselves do. Bringing people together in teams, with a common goal of improvement, aids communication between departmental or functional activities. Teamwork slowly breaks down the communication barriers and acts as a platform for change. Communication is part of the cement that holds together the bricks of Kaizen processes supporting the principle of people-based management.

To communicate properly, it is necessary to focus on the receiver of the message. Communication is very much a two-way process. For successful communication, you need to build credibility into the message and in the person giving the message. Anything that detracts from this does damage to both. Teamwork also enables a group of people to work as a task force, looking at cross-functional problems, or as an action team, solving local problems, in order to identify and adopt new ways of doing things.

Effective communication: is an essential facet of people management. For business success, regular, two-way communication, particularly face to face with employees and team members, is an important factor in establishing trust and a feeling of being valued. Two-way communication is regarded as both a core management competency and as a key management responsibility. For example, a typical list of management responsibilities for effective communication is to:

- Regularly meet all the members.
- Ensure people are briefed on key issues in a language free of technical jargon.
- Communicate honestly and as fully as possible on all issues which affect the employees.
- Encourage team members/employees to discuss company issues and give upward feedback.
- Ensure issues from team members/employees are fed back to senior managers and timely replies given.

Brainstorming: Brainstorming is a method of getting a group of people to generate a lot of ideas in a short space of time without assessing their value. Group thinking usually produces more ideas than individual thinking. It is used in teams, when trying to identify possible root causes or when seeking solution to a problem. Brainstorming can also be used when deciding what problem or improvement activity to work on, and when planning the steps of a project.

Brainstorming is a technique that was developed in 1930 by Alex Osborne as a way of encouraging groups to be more creative with their ideas. It is important to recognize that there are barriers to creative thinking. One is the tendency to assume that the way things have always been done is the only way they can be done. We often hear people say, “Yes, but we’ve always done it this way!” Another barrier is the fear of looking foolish. This fear limits our range of contribution—to things that are safe and conventional—and leads to our giving the expected answer. A third barrier is the tendency to make hasty judgment on what is said, without careful consideration. How many ideas get thrown in the waste bin without anyone really thinking about them and trying them, merely because they initially seem impractical, impossible, or crazy? A fourth barrier is the commonly

ICT ITS1	Version:01	Page No.41
	Copyright: Ethiopia Federal TVET Agency	



held view that there is always one right solution to every problem. This leads people to look for the obvious and logical answer rather than the less obvious, creative solution.

Brainstorming seems very simple. It works best when the team meeting is informal. To help this there are eight basic rules:

1. Keep the meeting relaxed.
2. Select a leader to write the ideas on a flip chart.
3. Involve the right people in the team.
4. Define the problem clearly. You will need to check that everyone present has the same understanding of the problem. This can be difficult to achieve in practice. A useful first stage of any brainstorm could involve a brief discussion of the problem before a definition is agreed.
5. Generate as many ideas as possible without discussion or evaluation. The more creative ideas the better. There are two main ways of doing this. The first is simply to invite people to contribute and write the ideas down as they are suggested. This is called the 'free wheeling' method. The second is to go round the room asking each person in turn for his or her contribution. This is called the 'round robin' method.
6. Encourage everyone to contribute. This is best done by beginning the session with a trivial example, such as 'uses of a paper cup', to get everyone started before moving on to the question in hand.
7. Write down every idea. There should be no censorship and there is no such thing as a bad idea. Sometimes strange ideas open up a new area of thought. Build on other people's ideas.
8. Following the brainstorm, a technique such as list reduction method should be used to reduce the brainstormed list to manageable proportions.
9. Don't criticize other people's ideas.
10. Every member should speak freely, there are no dumb ideas.

Benefits of brainstorming: by encouraging everyone to contribute, brainstorming breaks down barriers between departments and levels of hierarchy. It therefore allows everyone to contribute equally to the team. Brainstorming encourages cooperative and collaborative behavior and is also useful in the development of group work skills. Remember that brainstorming involves collecting people's ideas and opinions and that it might be necessary to collect data following the brainstorm to allow any decisions to be taken on the basis of fact.

3.8 Concept and parts of Kaizen board

Kaizen board is a bulletin board set up at a workplace or in a publicly accessible place in the factory or the company in order to disseminate information about the Kaizen activities at the workplace and the company. Information put up on the board includes various Kaizen-related news and announcements, either company-wide one or particular workplace related. A summary of QC Circle activity result can be posted. It is a means of management -employee communication. Information sharing in this manner helps foster employees' sense of participation, recognition and motivation in Kaizen activities.

Every working team or KPT has to prepare and use a Kaizen board. This encourages for the teams to work "as independent as possible" and transform their ideas to improvements. As long as every team uses a Kaizen board, it becomes also easy for the

ICT ITS1	Version:01	Page No.42
	Copyright: Ethiopia Federal TVET Agency	



management to be informed at any time, just by walking around and checking the information on the board. In general a Kaizen board is important for:

- Continuous Kaizen activity in a company or organization.
- Participation of all employees during Kaizen activity through Suggestion system.
- Employees including management to know about Kaizen performance in their work area or organization.
- Employees and management to know about production plans and performance.

The size of a Kaizen board should be 2 times a flip chart paper. It has four corners or parts depending on the information displayed.

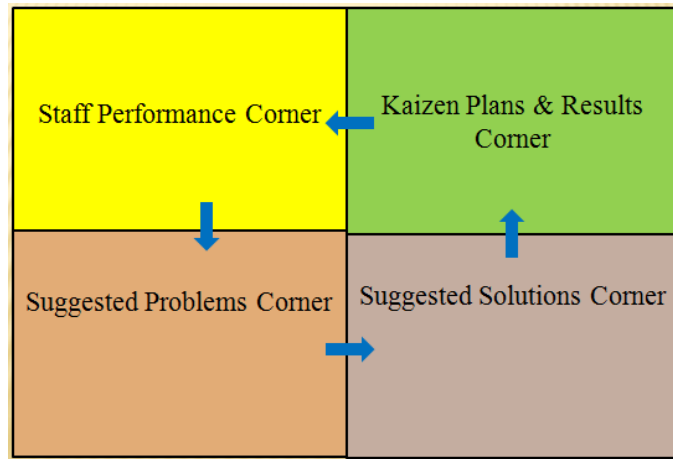

- The “staff performance corner” shows the actual performance of the staff and the gaps and training needs. The staff performance can be shown on the Kaizen board using different colors such as red for low performer, blue for average performer, and green for best performer.
- The “Kaizen plans & results corner” shows the results generated from implementing Kaizen activities. Improvement graphs can be displayed and should be updated regularly at least on weekly basis. If the results are below the planned target, the team has to discuss and find the root cause and implement solution.
- The “suggested problems corner” is the place where every team members’ ideas or identified problems are posted. The posted problems have to be discussed and solved by the teams and the solutions should be displayed on the next corner i.e. “suggested solutions corner”.
- The “suggested solutions corner” displays the solutions suggested for known problems. And the solution ideas have to be implemented and the results achieved have to be shown on the “Kaizen results corner”.



Self-Check 3	Written Test
---------------------	---------------------

Instructions: Read the following questions and write your answers in the answer sheet provided:

1. What are QCC or KPT? (3 points)
2. Describe the aims and benefits of QCC /KPT? (6 points)
3. What are the principles of QCC/KPT? (5 points)
4. Show by a diagram the structure of QCC/KPT? (5 points)
5. What are the roles of the components of QCC or KPT? (10 points)
6. What are the four stages of KPT categorized by EKI? (4 points)
7. What is a Kaizen board? (3 points)

Note: Satisfactory rating - 18 points Unsatisfactory - below 18 points

You can ask you teacher for the copy of the correct answers.

ICT ITS1	Version:01	Page No.44
	Copyright: Ethiopia Federal TVET Agency	



Answer Sheet

Score = _____

Rating: _____

Name: _____

Date: _____

Short Answer Questions

1. _____

2. _____

3. _____

4. _____

5. _____



6. _____

7. _____

Operation Sheet 1	Recognition of current situation before implementing 5S
--------------------------	----------------------------------------------------------------

Use 5S checklist

	A	B	Evaluation items	Evaluation po	Remarks about problems
Seiri	<input type="radio"/>		1) Necessary things and unnecessary things can be identified easily.		
	<input type="radio"/>		2) Unnecessary things are discarded, or clarified in time limit for handling.		
	<input type="radio"/>		3) Quantity of each thing is kept as specified.		
	<input type="radio"/>		4) Bulletins and control sheets are replaced with updates.		
			Subtotal		
Seiton	<input type="radio"/>		5) Things are located at each given place.		
	<input type="radio"/>		6) Fixed positions of things are clarified by signboard, delineating, etc.		
	<input type="radio"/>		7) Things are positioned so as to facilitate first-in first-out system.		
	<input type="radio"/>		8) Small improvement realizes easy transfer of things into and from each given place.		
			Subtotal		
Seiso	<input type="radio"/>		9) There are no stain, trash, dust, etc. (facilities, floor, building, lighting, etc.)		
	<input type="radio"/>		10) Upstream solutions are provided against stain, trash, dust, etc.		
	<input type="radio"/>		11) Voluntary inspection of facilities is conducted.		
	<input type="radio"/>		12) Processes, aisles, etc. are delineated with paint colors, etc. so that cleaning area can be easily identified.		
	<input type="radio"/>		13) There are no stain/separation/unevenness/cracks in painted/delineated part on the floor.		
	<input type="radio"/>		14) There are no obstacles on aisles. (carts, pallets, parts, etc.)		
	<input type="radio"/>		15) Cleaning is facilitated with creative efforts.		
			Subtotal		
Seiketsu	<input type="radio"/>		16) Judgment criteria for necessary/unnecessary things are specified.		<div style="border: 1px solid black; padding: 5px; width: fit-content;"> Items to evaluate the system of 3S (Red Tag Operation, Signboard Operation, and Tidy-it-Up Operation) </div>
	<input type="radio"/>		17) Judgment criteria for disposing unnecessary things are specified.		
	<input type="radio"/>		18) Quantities of necessary things are specified.		
	<input type="radio"/>		19) Fixed positions of necessary things are specified by signboards, layout chart, etc.		
	<input type="radio"/>		20) Heights of racks, etc. are specified.		
	<input type="radio"/>		21) Method/procedure/responsible person/time frame of cleaning are specified.		
	<input type="radio"/>		22) Contents/procedure/responsible person/time frame of voluntary facility inspection are specified.		
	<input type="radio"/>		23) Workers keep neat appearance and have no stain on their clothes, etc.		
	<input type="radio"/>		24) Progress/normality/abnormality in 3S (Seiri, Seiton, Seiso) can be easily identified.		
	<input type="radio"/>		25) Comfortable worksite is maintained through repeated 3S activity.		
			Subtotal		
Shitsuke	<input type="radio"/>		26) Annual policy for 5S activity is set.		
	<input type="radio"/>		27) Annual basic plan for 5S activity is set.		
	<input type="radio"/>		28) 5S activity plan is set for each worksite.		
	<input type="radio"/>		29) Awareness campaign, education, events, and patrols are included in activity plan.		
	<input type="radio"/>		30) 5S evaluation sheet is specially prepared for each worksite.		
	<input type="radio"/>		31) Supervisor prepares "Shitsuke Evaluation Sheet" for workers.		
	<input type="radio"/>		32) Supervisor repeatedly instructs workers on their weak points in Shitsuke.		
	<input type="radio"/>		33) Patrols by the person in each duty position are provided.		
	<input type="radio"/>		34) Responsible persons for patrols properly give advices and take actions.		
	<input type="radio"/>		35) Activity bulletin board is efficiently utilized for timely notice and understandability.		
	<input type="radio"/>		36) Bottom-up activities such as small improvements are invigorated.		
			Subtotal		
				Total	/105
				Achievement rate	%

<Evaluation criteria>

Grade the results of each activity in each evaluation item on a scale of zero to three as follows:

3 points	85% or more
2 points	60% or more but less than 85%
1 point	30% or more but less than 60%
0 point	Less than 30%

Photography

(1) Fixed-point Observation Type: Fix the location of your camera and do photo shoots at the same place both before and after 5S.

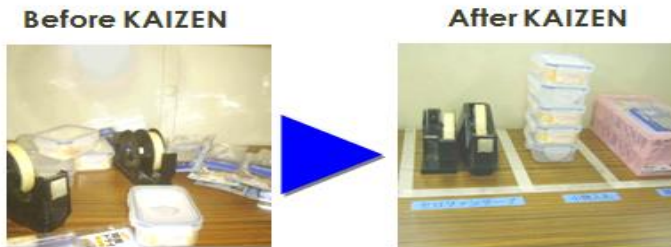

(2) Random Type: take photos of places randomly that need 5S implementation.

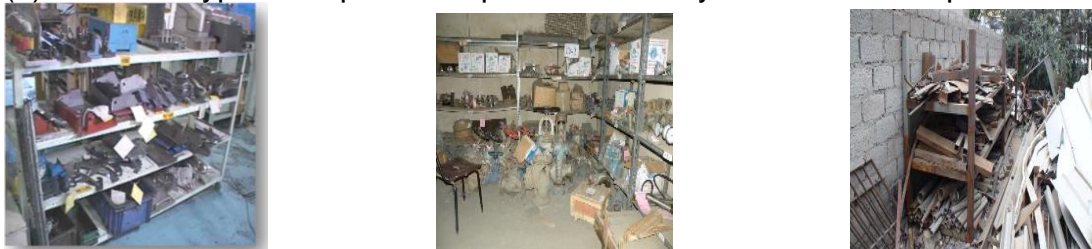



Operation Sheet 2	Preparing plan for 5S implementation
--------------------------	---------------------------------------------

1) 5S promotion plan (sample)

The following template can be used to prepare a plan for 5S implementation.

Date of issue: _____																								
Issued by 5S Promotion Office																								
Overall Plan for 5S Promotion																								
Items	Month 1				Month 2				Month 3				Month 4				Month 5				Month 6			
	Timing	1w	2w	3w	4w	1w	2w	3w	4w	1w	2w	3w	4w	1w	2w	3w	4w	1w	2w	3w	4w			
Basic plan (stage)	Preparation				Seiri				Shitsui				Seiton				Seiketsu				Seiso			
Preparation of 5S Tools	◆				◆				◆				◆				◆				◆			
Preparation of textbook for 5S Introductory training	◆				◆				◆				◆				◆				◆			
5S Introductory training	◆				◆				◆				◆				◆				◆			
5S training	◆				◆				◆				◆				◆				◆			
Photography	◆				◆				◆				◆				◆				◆			
Photographs on later stages can be the evaluation objects for 5S awarding.																								

2) This template can be used to prepare plan for 5S.

Activities	Timing							
	Week 1	Week 2	Week 3	Week 4	Week 5	Week 6	Week 7	Week 8
Establish KPT								
Recognition of current place								
Decide target areas								
Set goal								
etc								



Operation Sheet 3	Prepare Kaizen board
--------------------------	-----------------------------

Materials

- Chip wood
- measuring tape
- Sponge
- nails
- hook
- Cloth
- Others

Size is two times flip chart

Materials needed when using Kaizen board

- Pins: green, red, and blue - (red for low performer, blue for average performer, and green for best performer).
- Markers
- Problem and solution formats
- Plaster
- Papers



LAP Test	Practical Demonstration
-----------------	--------------------------------

Name: _____ Date: _____

Time started: _____ Time finished: _____

Instructions: Given necessary templates, workshop, tools and materials you are required to perform the following tasks.

Task 1: Using the given 5S check list, study the current situation of your workshop.

Task 2: Using the given template, prepare plan for 5S implementation in your workshop.

Task 3: Make a Kaizen board and make it ready for use.



ICT ITS1	Version:01	Page No.51
	Copyright: Ethiopia Federal TVET Agency	



Instruction Sheet	LG06: Prepare for work
--------------------------	-------------------------------

This learning guide is developed to provide you the necessary information regarding the following content coverage and topics –

- Using work instructions.
- Reading and interpreting Job specifications.
- Observing OHS requirements.
- Selecting appropriate materials.

Identifying and checking safety equipment and tools This guide will also assist you to attain the learning outcome stated in the cover page. Specifically, upon completion of this Learning Guide, you will be able to –

- Use work instructions to determine job requirements, including method, material and equipment.
- Read and interpret job specifications following working manual.
- Use OHS requirements, including dust and fume collection, breathing apparatus, eye and ear personal protection throughout the work.
- Select and prepare materials for work which are appropriate to application.
- Identify and check safety equipment and tools for safe and effective operation.

Learning Instructions:

7. Read the specific objectives of this Learning Guide.
8. Follow the instructions described below 3 to 6.
9. Read the information written in the information “Sheet 1, Sheet 2, Sheet 3 and Sheet 4”.
10. Accomplish the “Self-check 1, Self-check t 2, Self-check 3 and Self-check 4” in **page -6, 9, 12 and 14** respectively.
11. If you earned a satisfactory evaluation from the “Self-check” proceed to “Operation Sheet 1, Operation Sheet 2 and Operation Sheet 3” in **page -15**.
12. Do the “LAP test” in **page – 16** (if you are ready).



Information Sheet-1

Job Requirements

1. Job Requirements

A Job can be defined as:

- A piece of work, especially a specific task done as part of the routine of one's occupation or for an agreed price.
- A post of employment; full-time or part-time position
- Anything a person is expected or obliged to do; duty; responsibility
- An affair, matter, occurrence, or state of affairs.
- The material, project, assignment, etc., being worked upon.
- The process or requirements, details, etc., of working.
- The execution or performance of a task.

The requirements for a job vary according to the nature of the job itself. However, a certain work ethic must be cultivated to succeed in any job and this is fundamental to an individual's sense of himself as a worker, as part of production relations and a fundamental economic being. The basic requirements for a job remain the same no matter what the job is, where it is located or what professional and educational qualifications are required for it. These are as follows:

Discipline: Nothing is possible without discipline. Any job requires a fundamental core of discipline from the worker or the employee and this is a quality which is independent of age, post, stature, job and so on. Discipline is absolutely indispensable and provides the impetus for work that can be strenuous, repetitive, boring and even unsatisfactory at times.

Enthusiasm: Enthusiasm for work is also a pre-requisite for any job. An innate love for the job, which in modern parlance is known as job satisfaction, is a core requirement for any job. The drive to succeed, to innovate, to do well and to make one's profession into one's livelihood is a critical drive which needs to be present in the employee or cultivated as soon as possible. No job, however perfectly carried out, can evoke the feeling of satisfaction of a job well done without the instinct for success.

Qualifications: This is a more material, tactile need for a job which can be conveyed through degrees and certificates. However, education is not limited to what is taught in colleges or vocational training courses. It is the burning desire to learn more, to reach the depths of knowledge about a particular field of interest, to complete the job and learn from it that marks the true enthusiast and the truly learned.

Soft Skills: Soft skills include those skills which ensure that a job is executed well, and the employee can carry himself in the proper manner too. For example, good and smooth communication, computer skills, proficiency in language if needed, presentable appearance, the ability to manage crises are all soft skills which are fundamentally important in any job and which must be cultivated consciously.

Thus, the requirements of a job, though specific to it, cover also a general spectrum. These make for better employees and better individuals.

2. Work Instruction

ICT ITS1	Version:01	Page No.53
	Copyright: Ethiopia Federal TVET Agency	



Information about the work

- Describe what workers need to be able to do on the job
 - ✓ Work functions
 - ✓ Key activities of each work function
 - ✓ Performance indicators
- Describe what task to be done or work roles in a certain occupation

Work instruction is a description of the specific tasks and activities within an organization. A work instruction in a business will generally outline all of the different jobs needed for the operation of the firm in great detail and is a key element to running a business smoothly.

In other words it is a document containing detailed instructions that specify exactly what steps to follow to carry out an activity. It contains much more detail than a Procedure and is only created if very detailed instructions are needed. For example, describing precisely how a Request for Change record is created in the Change Management software support tool.

3. Procedures vs. Work Instructions

Many people confuse “procedures” with “work instructions”. In fact, most people write work instructions and call them procedures. Knowing the differences of procedures vs work instructions can help you understand the documentation process much better and, therefore, procedure documentation.

Procedures describe a process, while a work instruction describes how to perform the conversion itself. Process descriptions include details about the inputs, what conversion takes place (of inputs into outputs), the outputs, and the feedback necessary to ensure consistent results. The PDCA process approach (Plan, Do, Check, Act) is used to capture the relevant information.

Questions that need to be answered in a procedure include:

- Where do the inputs come from (suppliers)?
- Where do the outputs go (customers)?
- Who performs what action when (responsibilities)?
- How do you know when you have done it right (effectiveness criteria)?
- What feedback should be captured (metrics)?
- How do we communicate results (charts, graphs and reports)?
- What laws (regulations) or standards apply (e.g., ISO 9001, 8th EU Directive, IFRS, Sarbanes-Oxley)?

ICT ITS1	Version:01	Page No.54
	Copyright: Ethiopia Federal TVET Agency	



Job Specification

A statement of employee/workers characteristics and qualifications required for satisfactory performance of defined duties and tasks comprising a specific job or function.

Specification Sample

Technical parameters	Gigabyte 3D Rocket II (GH-PCU23-YE)
Heatsink and fan dimensions (L x W x H)	112mm x 112mm x 160mm 92mm x 92mm x 25mm
Heatsink material	aluminum plates on a copper base and four copper heatpipes 6mm in diameter
Fan rotation speed	~1500-3000rpm
Airflow	no data
Noise level	16.0 ~ 33.5 dBA
Nominal voltage	~12V
Fan MTBF	50,000h
Maximum power consumption	~4.6W
Fan bearings	2 frictionless bearings
Full weight	640g
Supported CPU sockets	Socket 478, LGA 775, Socket AM2/754/939/940
Additional	Additional fan in the lower part of the cooler Gigabyte thermal grease Replaceable fluorescent rings
Price, USD	\$60



Self-Check 1	Written Test
---------------------	---------------------

Directions: Answer all the questions listed below. Use the Answer sheet provided in the next page:

9. What is the meaning of job? (2 points)
10. List the requirements of job. (5 points)
11. What is the meaning of work? (2 points)
12. Describe work instruction in your own words. (5 points)
13. Explain the difference between procedure and work instruction? (5 points)
14. Define job specification? (3 points)
15. Prepare specification samples. (10 points)



Note: Satisfactory rating - 16 points Unsatisfactory - below 16 points

You can ask you teacher for the copy of the correct answers.

Answer Sheet

Score = _____

Rating: _____

Name: _____

Date: _____

Short Answer Questions

9. _____

10. _____

11. _____

12. _____

13. _____



14.

15.



1. OHS Requirements

OHS requirements are legislation/regulations/codes of practice and enterprise safety policies and procedures. This may include protective clothing and equipment, use of tooling and equipment, workplace environment and safety, handling of material, use of firefighting equipment, enterprise first aid, hazard control and hazardous materials and substances.

Personal protective equipment include those prescribed under legislation/regulations/codes of practice and workplace policies and practices. Safe operating procedures include the conduct of operational risk assessment and treatments associated with workplace organization. Emergency procedures include emergency shutdown and stopping of equipment, extinguishing fires, enterprise first aid requirements and site evacuation.

Occupational safety and health (OSH) also commonly referred to as occupational health and safety (OHS) or workplace health and safety (WHS) is an area concerned with the safety, health and welfare of people engaged in work or employment. The goals of occupational safety and health programs include fostering a safe and healthy work environment. OSH may also protect co-workers, family members, employers, customers, and many others who might be affected by the workplace environment. In the United States the term occupational health and safety is referred to as occupational health and occupational and non-occupational safety and includes safety for activities outside work.

Occupational safety and health can be important for moral, legal, and financial reasons. In common-law jurisdictions, employers have a common law duty (reflecting an underlying moral obligation) to take reasonable care for the safety of their employees. Statute law may build upon this to impose additional general duties, introduce specific duties and create government bodies with powers to regulate workplace safety issues: details of this will vary from jurisdiction to jurisdiction. Good OSH practices can also reduce employee injury and illness related costs, including medical care, sick leave and disability benefit costs.

As defined by the World Health Organization (WHO) "occupational health deals with all aspects of health and safety in the workplace and has a strong focus on primary prevention of hazards." Health has been defined as "a state of complete physical, mental and social well-being and not merely the absence of disease or infirmity. Occupational health is a multidisciplinary field of healthcare concerned with enabling an individual to undertake their occupation, in the way that causes least harm to their health. It contrasts, for example, with the promotion of health and safety at work, which is concerned with preventing harm from any incidental hazards, arising in the workplace.

Since 1950, the International Labour Organization (ILO) and the World Health Organization (WHO) have shared a common definition of occupational health. It was adopted by the Joint ILO/WHO Committee on Occupational Health at its first session in 1950 and revised at its twelfth session in 1995. The definition reads: "The main focus in occupational health is on three different objectives: (i) the maintenance and promotion of



workers' health and working capacity; (ii) the improvement of working environment and work to become conducive to safety and health and (iii) development of work organizations and working cultures in a direction which supports health and safety at work and in doing so also promotes a positive social climate and smooth operation and may enhance productivity of the undertakings. The concept of working culture is intended in this context to mean a reflection of the essential value systems adopted by the undertaking concerned. Such a culture is reflected in practice in the managerial systems, personnel policy, principles for participation, training policies and quality management of the undertaking."

Joint ILO/WHO Committee on Occupational Health: those in the field of occupational health come from a wide range of disciplines and professions including medicine, psychology, epidemiology, physiotherapy and rehabilitation, occupational, occupational medicine, human factors and ergonomics, and many others. Professionals advise on a broad range of occupational health matters. These include how to avoid particular pre-existing conditions causing a problem in the occupation, correct posture for the work, frequency of rest breaks, preventative action that can be undertaken, and so forth.

"Occupational health should aim at: the promotion and maintenance of the highest degree of physical, mental and social well-being of workers in all occupations; the prevention amongst workers of departures from health caused by their working conditions; the protection of workers in their employment from risks resulting from factors adverse to health; the placing and maintenance of the worker in an occupational environment adapted to his physiological and psychological capabilities; and, to summarize, the adaptation of work to man and of each man to his job.

2. History



Harry McShane, age 16, 1908. Pulled into machinery in a factory in Cincinnati and had his arm ripped off at the shoulder and his leg broken without any compensation. The research and regulation of occupational safety and health are a relatively recent phenomenon. As labor movements arose in response to worker concerns in the wake of the industrial revolution, worker's health entered consideration as a labor-related issue.

In 1833, HM Factory Inspectorate was formed in the United Kingdom with a remit to inspect factories and ensure the prevention of injury to child textile workers. In 1840 a Royal Commission published its findings on the state of conditions for the workers of the mining industry that documented the appallingly dangerous environment that they

ICT ITS1	Version:01	Page No.60
	Copyright: Ethiopia Federal TVET Agency	



had to work in and the high frequency of accidents. The commission sparked public outrage which resulted in the Mines Act of 1842. The act set up an inspectorate for mines and collieries which resulted in many prosecutions and safety improvements, and by 1850, inspectors were able to enter and inspect premises at their discretion.

Otto von Bismarck inaugurated the first social insurance legislation in 1883 and the first worker's compensation law in 1884 – the first of their kind in the Western world. Similar acts followed in other countries, partly in response to labor unrest.

3. Workplace hazards

Although work provides many economic and other benefits, a wide array of workplace hazards also present risks to the health and safety of people at work. These include "chemicals, biological agents, physical factors, adverse ergonomic conditions, allergens, a complex network of safety risks," and a broad range of psychosocial risk factors.

Physical and mechanical hazards



At-risk workers without appropriate safety equipment

Physical hazards are a common source of injuries in many industries. They are perhaps unavoidable in certain industries, such as construction and mining, but over time people have developed safety methods and procedures to manage the risks of physical danger in the workplace. Employment of children may pose special problems. Falls are a common cause of occupational injuries and fatalities, especially in construction, extraction, transportation, healthcare, and building cleaning and maintenance.

An engineering workshop specializing in the fabrication and welding of components has to follow the Personal Protective Equipment (PPE) at work regulations 1992. It is an employer's/workers duty to provide 'all equipment (including clothing affording protection against the weather) which is intended to be worn or held by a person at work which protects him against one or more risks to his health and safety'. In a fabrication and welding workshop an employer would be required to provide face and eye protection, safety footwear, overalls and other necessary PPE.

Machines are commonplace in many industries, including manufacturing, mining, construction and agriculture, and can be dangerous to workers. Many machines involve moving parts, sharp edges, hot surfaces and other hazards with the potential to crush, burn, cut, shear, stab or otherwise strike or wound workers if used unsafely. Various safety measures exist to minimize these hazards, including lockout-tag out procedures for machine maintenance and roll over protection systems for vehicles.

ICT ITS1	Version:01	Page No.61
	Copyright: Ethiopia Federal TVET Agency	



According to the United States Bureau of Labor Statistics, machine-related injuries were responsible for 64,170 cases that required days away from work in 2008. More than a quarter of these cases required more than 31 days spent away from work. That same year, machines were the primary or secondary source of over 600 work-related fatalities. Machines are also often involved indirectly in worker deaths and injuries, such as in cases in which a worker slips and falls, possibly upon a sharp or pointed object.

The transportation sector bears many risks for the health of commercial drivers, too, for example from vibration, long periods of sitting, work stress and exhaustion. These problems occur in Europe but in other parts of the world the situation is even worse. More drivers die in accidents due to security defects in vehicles. Long waiting times at borders cause that drivers are away from home and family much longer and even increase the risk of HIV infections.

Confined spaces also present a work hazard. The National Institute of Occupational Safety and Health defines "confined space" as having limited openings for entry and exit and unfavorable natural ventilation, and which is not intended for continuous employee occupancy. Spaces of this kind can include storage tanks, ship compartments, sewers, and pipelines. Confined spaces can pose a hazard not just to workers, but also to people who try to rescue them.

Noise also presents a fairly common workplace hazard: occupational hearing loss is the most common work-related injury in the United States, with 22 million workers exposed to hazardous noise levels at work and an estimated \$242 million spent annually on worker's compensation for hearing loss disability. Noise is not the only source of occupational hearing loss; exposure to chemicals such as aromatic solvents and metals including lead, arsenic, and mercury can also cause hearing loss.

Temperature extremes can also pose a danger to workers. Heat stress can cause heat stroke, exhaustion, cramps, and rashes. Heat can also fog up safety glasses or cause sweaty palms or dizziness, all of which increase the risk of other injuries. Workers near hot surfaces or steam also are at risk for burns. Dehydration may also result from overexposure to heat. Cold stress also poses a danger to many workers. Over-exposure to cold conditions or extreme cold can lead to hypothermia, frostbite, trench foot, or chilblains.

Electricity poses a danger to many workers. Electrical injuries can be divided into four types: fatal electrocution, electric shock, burns, and falls caused by contact with electric energy.

Vibrating machinery, lighting, and air pressure (high or low) can also cause work-related illness and injury. Asphyxiation is another potential work hazard in certain situations. Musculoskeletal are avoided by the employment of good ergonomic design and the reduction of repeated strenuous movements or lifts. Ionizing (alpha, beta, gamma, X, neutron), and non-ionizing radiation (microwave, intense IR, RF, UV, laser at visible and non-visible wavelengths), can also be a potent hazard

In Victoria, workplace health and safety is governed by a system of laws, regulations and compliance codes which set out the responsibilities of employers and workers to ensure that safety is maintained at work.

ICT ITS1	Version:01	Page No.62
	Copyright: Ethiopia Federal TVET Agency	



The Act

The *Occupational Health and Safety Act 2004* (the Act) is the cornerstone of legislative and administrative measures to improve occupational health and safety in Victoria.

The Act sets out the key principles, duties and rights in relation to occupational health and safety. The general nature of the duties imposed by the Act means that they cover a very wide variety of circumstances, do not readily date and provide considerable flexibility for a duty holder to determine what needs to be done to comply.

The Regulations

The *Occupational Health and Safety Regulations 2007* are made under the Act. They specify the ways duties imposed by the Act must be performed, or prescribe procedural or administrative matters to support the Act, such as requiring licenses for specific activities, keeping records, or notifying certain matters.

Guidance

Effective OHS regulation requires that Work Safe provides clear, accessible advice and guidance about what constitutes compliance with the Act and Regulations. This can be achieved through Compliance Codes, Work Safe Positions and non-statutory guidance ("the OHS compliance framework"). For a detailed explanation of the OHS compliance framework, see the Victorian Occupational Health and Safety Compliance Framework Handbook.

Policy

Not every term in the legislation is defined or explained in detail. Also, sometimes new circumstances arise (like increases in non-standard forms of employment, such as casual, labour hire and contract work, or completely new industries with new technologies which produce new hazards and risks) which could potentially impact on the reach of the law, or its effective administration by Work Safe. Therefore, from time to time Work Safe must make decisions about how it will interpret something that is referred to in legislation, or act on a particular issue, to ensure clarity. In these circumstances, Work Safe will develop a policy. A policy is a statement of what Work Safe understands something to mean, or what Work Safe will do in certain circumstances.

Self-Check 2	Written Test
---------------------	---------------------

Instructions: Answer all the questions listed below. Illustrations may be necessary to aid some explanations/answers. Write your answers in the sheet provided in the next page.

1. What is OHS represents for (2 point)
2. What is OSH representing for? (1 point)
3. What is WHS represents for? (1 point)
4. What are the goals of OHS? (2 points)

ICT ITS1	Version:01	Page No.63
	Copyright: Ethiopia Federal TVET Agency	



5. List some examples of OHS requirements in your work areas. (10 points)
6. List at least four workplace hazards? (4 points)

Note: Satisfactory rating - 12 points Unsatisfactory – below 12 points
You can ask your trainer for the copy of the correct answers.

Answer Sheet

Score = _____

Rating: _____

Name: _____

Date: _____

Short Answer Questions

1. _____



2.

3.

4.

5.

6.

Information Sheet 3	Material preparation and selection for work
----------------------------	----------------------------------------------------

Tools and materials used to implement Sort activity

Tools and materials are required to implement sort, set in order and shine activities in work stations. The following are some tools and materials used to implement the first pillar of 5S-Sort.

- red tags
- hook
- shelves
- sponge
- pencil
- formats (for recording necessary and unnecessary items, plans etc...)
- sticker
- nails
- chip wood
- broom
- shadow board/ tools board

Tools and materials used to implement set in order

The following are some tools and materials used to implement the second pillar of 5S-Set in order.

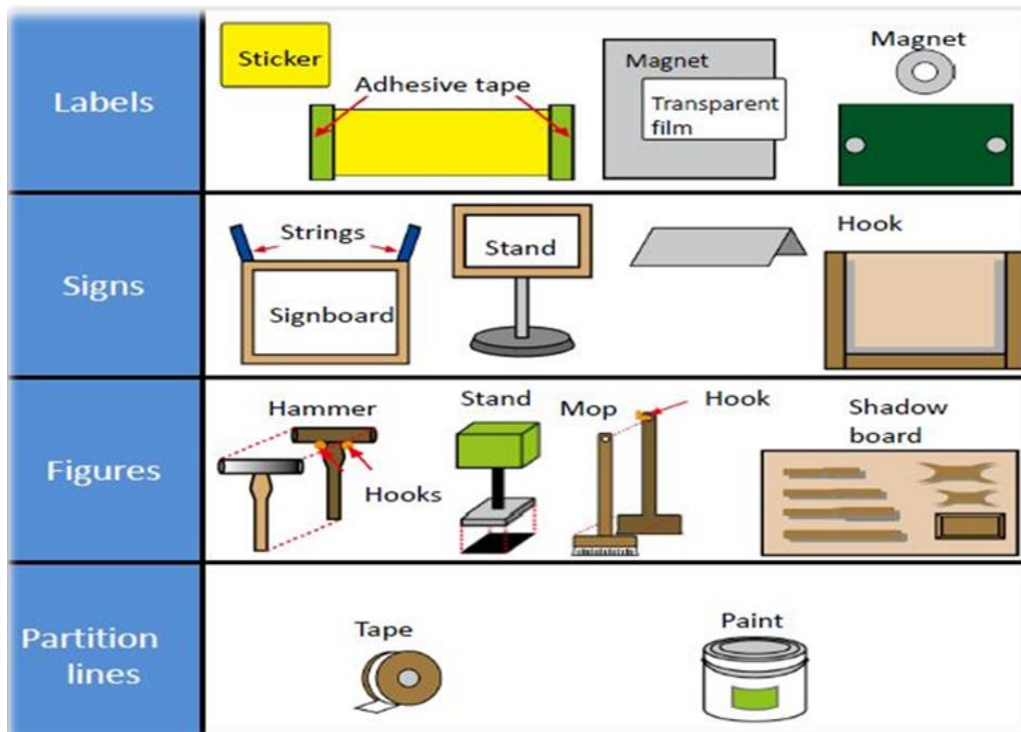

Tools and materials used to implement shine

The following are some tools and materials used to implement the third pillar of 5S-Shine.

- Sponge
- Broom
- oil
- detergent s

- Brush
- vacuum cleaner
- garbage containers
- screws etc...

- spade
- bolts
- floor scrubber cleaning Pads







Self-Check 3	Written Test
---------------------	---------------------

Instructions: Perform the following tasks. Write your answers in the answer sheet provided:

1. List at least five me tools and materials used to implement Sort. (5 points)
2. List at least six tools and materials used to implement Set in order. (6 points)
3. List at least seven tools and materials used to implement Shine. (7 points)

Note: Satisfactory rating - 10 points Unsatisfactory - below 10 points

You can ask you teacher for the copy of the correct answers.

ICT ITS1	Version:01	Page No.69
	Copyright: Ethiopia Federal TVET Agency	



Answer Sheet

Score = _____

Rating: _____

Name: _____

Date: _____

Short Answer Questions

1. _____

2. _____

3. _____

Operation Sheet 1

Prepare tools and materials for implementing 3S

ICT ITS1

Version:01

Copyright: Ethiopia Federal TVET Agency

Page No.70

1. Discuss and plan to prepare materials for 3S implementation

2. Prepare tools and materials for implementing sort

- red tags
- hook
- shelves
- sponge
- pencil
- formats (for recording necessary and unnecessary items, plans etc...)
- sticker
- nails
- chip wood
- broom
- shadow board/ tools board

3. Prepare tools and materials for implementing set in order

Labels	
Signs	
Figures	
Partition lines	

Prepare tools and materials for implementing shine

- sponge
- broom
- detergent s
- brush
- spade
- vacuum cleaner
- oil
- bolts
- garbage containers
- floor scrubber cleaning Pads
- screws etc...

LAP Test	Practical Demonstration
-----------------	--------------------------------



Name: _____ Date: _____

Time started: _____ Time finished: _____

Instructions: Given necessary templates, workshop, tools and materials you are required to perform the following tasks.

Task 1: Identify and prepare tools and materials for implementing sort activity.

Task 2: Identify and prepare tools and materials to implement set in order.

Task 3: Identify and prepare tools and materials to implement shine activity.



**Instruction Sheet****LG07: Sort items**

This learning guide is developed to provide you the necessary information regarding the following content coverage and topics –

- Preparing Plan.
- Performing activities of cleaning.
- Following appropriate procedures.
- Identifying all Items.
- Appropriate format for listing items
- Listing necessary and unnecessary items.
- Using red tag strategy.
- Evaluating and placing unnecessary items.
- Appropriate format for recording and quantifying necessary items
- Recording and quantifying necessary items.
- Appropriate format for reporting
- Reporting performance results

Checking necessary items This guide will also assist you to attain the learning outcome stated in the cover page. Specifically, upon completion of this Learning Guide, you will be able to –

- Prepare plan for implementing sorting activities.
- Perform cleaning activities, in parallel.
- Identify all items in the work area following procedures.
- List necessary and unnecessary items using the appropriate format.
- Use red tag strategy for unnecessary items.
- Evaluate and place unnecessary items in an appropriate place other than the workplace.
- Record and quantify necessary items using appropriate format.
- Report performance results using appropriate formats.
- Regularly check necessary items in the work area.

Learning Instructions:

ICT ITS1	Version:01	Page No.74
	Copyright: Ethiopia Federal TVET Agency	



13. Read the specific objectives of this Learning Guide.
14. Follow the instructions described below 3 to 6.
15. Read the information written in the information “Sheet 1, Sheet 2, Sheet 3 and Sheet 4”.
16. Accomplish the “Self-check 1, Self-check t 2, Self-check 3 and Self-check 4” **in page -6, 9, 12 and 14** respectively.
17. If you earned a satisfactory evaluation from the “Self-check” proceed to “Operation Sheet 1, Operation Sheet 2 and Operation Sheet 3” **in page -15**.
18. Do the “LAP test” **in page – 16** (if you are ready).

ICT ITS1	Version:01	Page No.75
	Copyright: Ethiopia Federal TVET Agency	



Information Sheet-1

The first pillar of 5S - Sort

1. Explanation of the first pillar - Sort

1.1 Definition of Sort

Sort, the first pillar of 5S, means classifying items in the workplace into two categories – necessary and unnecessary - and removing all the unnecessary items that are not needed for current operations. It corresponds to the just in time (JIT) principle of “only what is needed, only in the amount needed, and only when it is needed.” The workplace is full of unused machines, jigs, dies, rejects, work-in-process, raw materials, supplies, parts, shelves, containers, desks, workbenches, files, carts, racks, pallets and other items.

People tend to hang onto parts, thinking that they may be needed for the next time. They see an inappropriate machine or equipment and think that they will use it somehow. In this way, inventory and equipment tend to accumulate and get in the way of everyday activities. This leads to a massive build of waste in companywide or in the whole workshop. An easy rule is to remove anything that will not be used within the next 30 days. A ceiling on the number of necessary items should be established.

Red-tag holding area can also help to evaluate the need of an item instead of simply getting rid of it. This greatly reduces the risk of disposing of an item that is needed later that will be explained in detail in the next contents.

1.2 Benefits of sort activity

Implementing this first pillar creates a work environment in which space, time, money, energy, and other resources can be managed and used most effectively. Sorting can lead to a much safer workplace. By clearing out the items you no longer need, people will have more room to work and things like trip hazards and items falling off shelves will be greatly reduced. Sorting also improves work flow since there is less clutter to deal with and will most definitely increase productivity in both production and office environments.

ICT ITS1	Version:01	Page No.76
	Copyright: Ethiopia Federal TVET Agency	



Step 1- Evaluate and take pictures of the work area. It's extremely important to take pictures during this evaluation step since referencing them after improvements have been made can be very enlightening. To help you get started use also a 5S evaluation form.

Step 2 - Identify and red tag the items you no longer need.

Step 3 - Decide what to do with the tagged items.

2.2 Record and quantify all items in the work area

The following sample formats can be used to record all necessary and unnecessary items.

A sample format for recording all items at the workplace.

2.3.2 Red-tag Holding areas

In order to implement the red-tag strategy effectively, a red-tag holding area must be created. A red-tag holding area is an area set aside for use in storing red-tagged items that need further evaluation. Red-tagging is helpful when the need or frequency of need for that item is unknown. When an item is set aside in a red-tag holding area and watched for an agreed-upon period of time people tend to be more ready to let it go when that time is over.

There are two red-tag holding areas: local and central holding areas. Local red-tag holding area is used to manage the flow of red-tagged items with in a local department or production area. Central red-tag holding area is used to manage the flow of items that cannot or should not be disposed of by individual departments or production area. Usually central red-tag holding area is used by an organization that is launching a companywide red-tagging effort.

Red-tag Holding Area

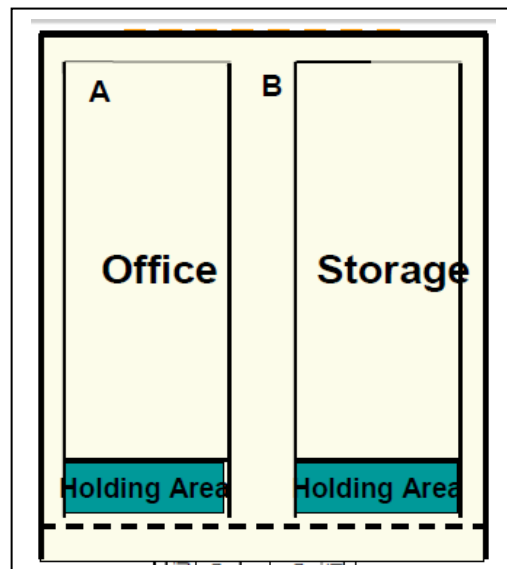
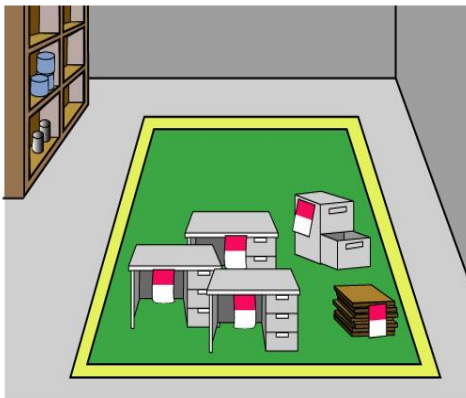



2.3.3 Steps/procedures in Red tagging

The red-tagging process in a department or work area can be broken down into seven steps.

- Step 1: Launch the red-tag project.
- Step 2: Identify the red-tag targets.
- Step 3: Set red-tag criteria.
- Step 4: Make red tags.
- Step 5: Attach red tags.
- Step 6: Evaluate red-tagged items.
- Step 7: Document the results of red-tagging.

Step 1: Launch the red-tag project

Red-tag campaigns are started and coordinated by the upper-level management of a company. Even when a red-tag campaign is companywide, local campaigns need to be organized in each department or production area. This involves

- Organizing a team
- Organizing supplies
- Organizing a time or schedule to perform red-tagging
- Deciding a local-tag holding area
- Planning for disposal of red-tagged items

People from outside a department can be valuable members on a red-tagging team since they tend to see the area with a fresh eye. Hence, it is helpful to partner with other departments or production areas in creating red-tagging teams.

Step 2: Identify red-tag targets

There are two red-tag targets:

- a) Items: in the manufacturing area items like inventory (warehouse and in-process inventory), equipment, and space are targets for red tags. Warehouse inventory include material, parts, products etc.
- b) Areas: It is better to define a smaller area and evaluate it well than to define a larger area and not be able to evaluate it fully in available time.

ICT ITS1	Version:01	Page No.82
	Copyright: Ethiopia Federal TVET Agency	

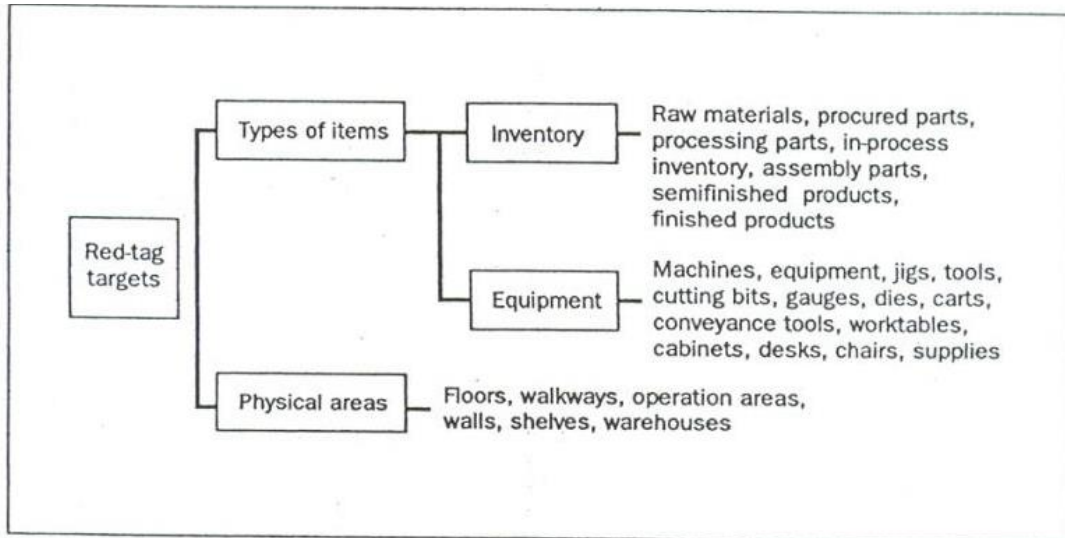

Step 3: Set red-tag criteria

As already mentioned, the most difficult thing about red-tagging is differentiating what is needed from what is not. This issue can be managed by establishing clear-cut criteria for what is needed in particular area and what is not. The most common criterion is the next month's production schedule.

- Items needed for that schedule are kept in that location.
- Items not needed for the schedule can be disposed of or stored in a separate location.

Three main factors determine whether an item is necessary or not. These factors are:

- The usefulness of the item to perform the work at hand. If the item isn't needed it should be disposed of.
- The frequency with which the item is needed. If it is needed infrequently it can be stored away from the work area.
- The quantity of the item needed to perform this work. If it is needed in limited quantity the excess can be disposed or stored away from the work area.

Each company must establish its own red-tagging criteria and each department may customize this standard to meet its local needs.



Step 4: Make red-tags

Each company has specific needs for documenting and reporting the movement, use, and value of materials, equipment, tools, inventory and products. The company's red tags should be designed to support this documentation process.

Various types of information on a red tag may include:

- **Category:** provides a general idea of the type of item (e.g., a warehouse item or machine). Categories include raw materials, in-process inventory, products, equipment, jigs, tools and dies.
- **Item name and manufacturing number.**
- **Quantity:** indicates the number of items included under this red tag.
- **Reason:** describes why a red tag has been attached to this item.
- **Division:** includes the name of the division responsible for managing the red-tagged item.
- **Value:** includes the value of the red-tagged item.
- **Date:** includes the red-tagging date.

RED TAG			
Category	1. Raw material 2. In-process stock ③ Semi-finished goods 4. Products	5. Machine and other equipment 6. Dies and jigs 7. Tools and supplies 8. Other	
Item name:	Door		
Manufacturing No.:	PX-180X		
Quantity:	2 Units	Value:	\$ (total)

Red Tag		No.
Name of applicant:	Date	
Name of item:	Quantity:	
Part No.:		
Location:		
Classification <input type="checkbox"/> 1. Material <input type="checkbox"/> 2. Part <input type="checkbox"/> 3. Inventory in-process <input type="checkbox"/> 4. Product <input type="checkbox"/> 5. Equipment/facilities <input type="checkbox"/> 6. Cutting tool <input type="checkbox"/> 7. Jig <input type="checkbox"/> 8. Fixing <input type="checkbox"/> 9. Others		
A: Reason for item of 1 to 4 <input type="checkbox"/> a. Miscalculation/mistakes in sales/production plan <input type="checkbox"/> b. Order cancellation <input type="checkbox"/> c. Design/specification change <input type="checkbox"/> d. Design error <input type="checkbox"/> e. Order error <input type="checkbox"/> f. Receipt error (Insufficient inspection) <input type="checkbox"/> g. Machining error <input type="checkbox"/> h. Assembly error <input type="checkbox"/> i. Obsolescence, Long time storage <input type="checkbox"/> j. Others		
B: Reason for item of 5 to 9 <input type="checkbox"/> k. Ageing <input type="checkbox"/> l. Out of order <input type="checkbox"/> m. No longer applicable <input type="checkbox"/> n. Others		

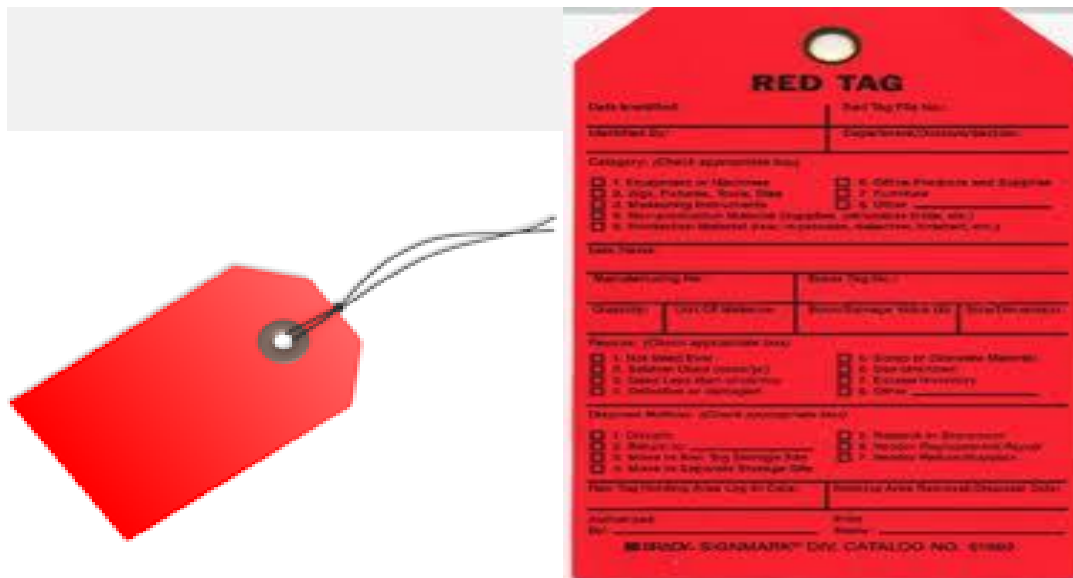

The material used for red tags can be red paper, thick red tape, or others. Red tags can be laminated with plastic or another material to protect them during repeated use.

Step 5: Attach the red tags

The best way to carry out red-tagging is to do the whole target area quickly, if possible, in one or two days. In fact, many companies choose to red-tag their entire factory during a one or two day period. Red-tagging should be a short and powerful event. You should red-tag all items you question, without evaluating what to do with them.

Step 6: Evaluate the red-tagged items

In this step, the red-tag criteria established in step 3 are used to evaluate what to do with red-tagged items. Options include:

- Keep the item where it is.
- Move the item to a new location in the work area.
- Store the item away from the work area.
- Hold the item in the local red-tag holding area for evaluation.
- Dispose of the item.

Disposal methods include:



- Throw it away.
- Sell it.
- Return it to the vendor.
- Lend it out.
- Distribute it to a different part of the company.
- Send it to the central red-tag holding area.

The next table shows disposal methods.

Treatment	Description
Throw it away	Dispose of as scrap or incinerate items that are useless or unneeded for any purpose.
Sell	Sell off to other companies items that are useless or unneeded for any purpose.
Return	Return items to the supply company.
Lend out	Lend items to other sections of the company that can use them on a temporary basis.
Distribute	Distribute items to another part of the company on a permanent basis.
Central red-tag area	Send items to the central red-tag holding area for redistribution, storage, or disposal.

Evaluation format for red-tag items (sample)



Evaluation Form of Red Tag Items							Date of issue: Issued by: 5S promotion office		Remarks
Stage: Seiri		Unused Period (month)	Red tag strategy				Unnecessary item list		
Object	Type		Red tag		Sorter		Required	Not required	
Material	Main	12	<input type="radio"/>		Leader	Manager	<input type="radio"/>		
	Supplement	6	<input type="radio"/>		Leader	Manager	<input type="radio"/>		
	Broken	1		<input type="radio"/>				Dispose	
Parts	Common Use	6	<input type="radio"/>		Leader	Manager	<input type="radio"/>		
	Exclusive use	3	<input type="radio"/>		Leader	Manager	<input type="radio"/>		
Inventory in-process		2	<input type="radio"/>		Leader	Manager	<input type="radio"/>		
Product		3	<input type="radio"/>		Manager	General manager	<input type="radio"/>		
Facility		6	<input type="radio"/>		Manager	General manager	<input type="radio"/>		
Die		6	<input type="radio"/>		Manager	General manager	<input type="radio"/>		
Jig		6	<input type="radio"/>		Leader	General manager	<input type="radio"/>		
Cutting tool		6	<input type="radio"/>		Leader	Manager	<input type="radio"/>		
Tool		3	<input type="radio"/>		Leader	Head of Section	<input type="radio"/>		
Measuring instrument		6	<input type="radio"/>		Leader	Head of Section	<input type="radio"/>		
Carrying equipment		2	<input type="radio"/>		Leader	Head of Section	<input type="radio"/>		

How to evaluate:
Evaluate items based on unused period of them.

How to prepare the form

- 5S committee set the standard by main unneeded item
- Explain contents of this form to each promotion block.
- Compile the form to help Seiri activity such as requirement of red tag and record on unnecessary item list.

Ideally, unnecessary equipment should be removed from areas where daily production activities take place. However, large equipment and equipment or machine attached to the floor may be expensive to move. It is sometimes better to leave this equipment where it is unless it interferes with daily production activities or prevents workshop improvements. Label this unneeded and difficult to move equipment with a “freeze” red tag, which indicates that its use has been “frozen,” but that it will remain in place for the time being.

Step 7: Document the results of red-tagging

Each company or organization needs to create its own system for logging and tracking necessary information as red-tagging takes place. The documentation system may involve a written logbook in each department and in the central red tag holding area. Or it may involve entering data from the red-tags into a computer system. Whatever the system, documenting results is an important part of the red-tagging process. It allows the company to measure the improvement and savings produced as a result of the red-tagging effort. As it is indicated in step 4, the red-tags should be designed to support the documentation process.

Determine in advance approximately how many red-tags each workplace should use. An average of four red-tags per employee should be used. This means a workshop with 30 employees should need about 120 red tags. In addition, when you find a shelf full of items which are difficult to decide, we don't have to be tempted to attach one red-tag for the whole shelf. Because this can lead to confusion when we want to dispose of these items in the shelf. Therefore, avoid this temptation and attach individual tags to individual items.

When red-tagging is completed the factory or workshop is usually dotted with empty spaces – a sign of real progress. Then the layout of equipments and worktables can be changed to occupy the free space. Companies or organizations who think they need to build a new factory for a production of new products/ services should first apply the sort activity or the red-tag strategy so that they could get plenty of free space.

2.3.4 Types of unnecessary items

Some of types of unnecessary items are:

- defective or excess quantities of small parts and inventory
- outdated or broken jigs and dies
- worn-out bits
- outdated or broken tools and inspection gear
- old rags and other cleaning supplies
- electrical equipment with broken cords
- outdated posters, signs, notices, and memos



Unused machinery or equipment



Obsolete equipment

2.3.5 Places where unnecessary items accumulate



Some locations where unneeded items tend to accumulate are:

- in rooms or areas not designated for any particular purpose
- in corners next to entrances or exists
- along interior and exterior walls, next to partitions, and behind pillars.
- under the eaves of warehouses.
- under desks and shelves and in desk and cabinet drawers
- near the bottom of tall stacks of items
- on unused management and production schedule boards
- in tools boxes that are not clearly sorted

ICT ITS1	Version:01	Page No.89
	Copyright: Ethiopia Federal TVET Agency	



Self-Check 1	Written Test
---------------------	---------------------

Instructions: Answer all the questions listed below. Illustrations may be necessary to aid some explanations/answers. Write your answers in the sheet provided in the next page.

1. Give definition of the first pillar of 5S – Sort. (3 points)
2. What are the benefits of implementing sort activity? (4 points)
3. What problems occur in a workshop if sort activity is not implemented? (6 points)
4. What are the reasons for the accumulation of unnecessary items in a workshop? (3 points)
5. What are the procedures for sort activity? (5 points)
6. What is red-tagging strategy? (3 points)
7. What are red-tag holding areas and explain the types? (4 points)
8. List the steps of red-tagging strategy. (7 points)
9. List at least seven items that are considered as unnecessary. (7 points)
10. Name places where unnecessary items are accumulated? (6 points)



Note: Satisfactory rating - 17 points Unsatisfactory - below 17 points
You can ask you teacher for the copy of the correct answers.

Answer Sheet

Score = _____

Rating: _____

Name: _____

Date: _____

7. _____

2. _____

3. _____

4. _____



5.

6.

7.

8.



9.

10.

Operation Sheet 1	Implementing sort activity
--------------------------	-----------------------------------

1. Preparing plan for Sort activity



Sample plan for sort activity

Preparation date: Year Month Day
Prepared by 5S Committee

Area : M-1

Basic Plan		Sort Activity																																																		
		1st month															2nd month																																			
Activity		18	19	20	21	22	23	24	25	26	27	28	29	30	1	2	3	4	5	6	7	8	9	10	11	12	13	14	15	16	17	18	19	20	21	22	23	24	25	26	27	28	29	30	31							
Determining activity area	Plan																																																			
	Result																																																			
Preparing documentations	Plan																																																			
	Result																																																			
Deciding where to put unnecessary things	Plan																																																			
	Result																																																			
Holding a briefing session	Plan																																																			
	Result																																																			
Red tagging	Plan																																																			
	Result																																																			
Filling out documentations	Plan																																																			
	Result																																																			
Quantification	Plan																																																			
	Result																																																			
General cleaning	Plan																																																			
	Result																																																			

2) Procedure for sort activity



List all items at the work place using the following sample format.

Sample red-tags

RED TAG			
Category	1. Raw material 2. In-process stock 3. Semi-finished goods 4. Products	5. Machine and other equipment 6. Dies and jigs 7. Tools and supplies 8. Other	
Item name:	Door		
Manufacturing No.:	PX-180X		
Quantity:	2 Units	Value:	\$ (total)

Red Tag		No.
Name of applicant:	Date	
Name of item:	Quantity:	
Part No.:		
Location:		
Classification <input type="checkbox"/> 1. Material <input type="checkbox"/> 2. Part <input type="checkbox"/> 3. Inventory in-process <input type="checkbox"/> 4. Product <input type="checkbox"/> 5. Equipment/facilities <input type="checkbox"/> 6. Cutting tool <input type="checkbox"/> 7. Jig <input type="checkbox"/> 8. Fixing <input type="checkbox"/> 9. Others		
A: Reason for item of 1 to 4 <input type="checkbox"/> a. Miscalculation/mistakes in sales/production plan <input type="checkbox"/> b. Order cancellation <input type="checkbox"/> c. Design/specification change <input type="checkbox"/> d. Design error <input type="checkbox"/> e. Order error <input type="checkbox"/> f. Receipt error (Insufficient inspection) <input type="checkbox"/> g. Machining error <input type="checkbox"/> h. Assembly error <input type="checkbox"/> i. Obsolescence, Long time storage <input type="checkbox"/> j. Others		
B: Reason for item of 5 to 9 <input type="checkbox"/> k. Ageing <input type="checkbox"/> l. Out of order <input type="checkbox"/> m. No longer applicable <input type="checkbox"/> n. Others		

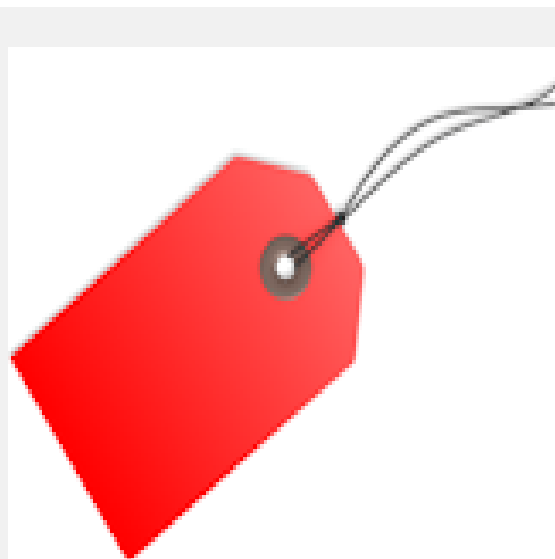

4) Record and quantify all items in the work area using the following formats.



Record tangible/quantitative results and changes that are achieved by applying Sort activity using the following indicators.

No	Improvement Indicators	Before Kaizen	Target	After Kaizen	Improvement (%)	Remark
1	Free floor space					
2	Searching time for tools, materials, etc					
3	Transaction made/income generated					
4	Labor saving					
5	Parts saving					
6	Tools& Equipment found					
7	Raw Material saving					
8	Transportation/travel					
9	Inventory					
10	Lead time					
11	Machine down time					
12	Frequency of Machine failure					
13	Production volume per day					
14	Labour productivity					
15	Delivery Time					
16	Defect rate					
17	Number of Customer complaints					
18	Minimized Cost of Production					



Qualitative Results

Record intangible/qualitative results and changes that are achieved by applying Sort activity using the following indicators.

No	Improvement Indicators	Description of the Result
1	Knowledge of the 1 st S - Sort	
2	Team work	
3	Morale of workers	
4	Communications between workers by removing unnecessary materials	
5	Corporate culture of kaizen	
6	Fatigue or stress	
7	Relationship with customers	
8	Awareness of safety	
9	Orderliness of work place	
10	Other	



LAP Test	Practical Demonstration
-----------------	--------------------------------

Name: _____ Date: _____

Time started: _____ Time finished: _____

Instructions: Given necessary templates, workshop, tools and materials you are required to perform the following tasks.

Task 1: Using the given template, prepare a plan for sort activity in your workshop.

Task 2: Using the given templates, list necessary and unnecessary items.

Task 3: Make red-tags appropriate for your workshop.

Task 4: Following the procedures of sort activity, perform sort activity in the assigned workshop.



ICT ITS1	Version:01	Page No.101
	Copyright: Ethiopia Federal TVET Agency	



Instruction Sheet	LG08: Set all items in order
--------------------------	-------------------------------------

This learning guide is developed to provide you the necessary information regarding the following content coverage and topics –

- . Preparing plan.
- . Performing general cleaning activities.
- . Deciding Location/layout, storage and indication methods.
- . Preparing and using tools and equipment.
- . Placing Items in their locations.
- . Returning items after use.
- . Reporting performance results.

. Checking items This guide will also assist you to attain the learning outcome stated in the cover page. Specifically, upon completion of this Learning Guide, you will be able to –

- Prepare plan for implementing set in order activities.
- Perform general cleaning activities, in parallel with set in order activity.
- Decide location/layout, storage and indication methods for items.
- Prepare and use necessary tools and equipment for setting in order activities.

- Place items in their assigned location.
- Return immediately the items to their assigned location after use.
- Report performance results using appropriate formats.
- Regularly check each item in its assigned location and order.

Learning Instructions:

19. Read the specific objectives of this Learning Guide.
20. Follow the instructions described below 3 to 6.
21. Read the information written in the information “Sheet 1, Sheet 2, Sheet 3 and Sheet 4”.
22. Accomplish the “Self-check 1, Self-check t 2, Self-check 3 and Self-check 4” in page -6, 9, 12 and 14 respectively.
23. If you earned a satisfactory evaluation from the “Self-check” proceed to “Operation Sheet 1, Operation Sheet 2 and Operation Sheet 3” in page -15.
24. Do the “LAP test” in page – 16 (if you are ready).

Information Sheet-1	The second pillar of 5S – Set in order
----------------------------	-----------------------------------------------

1. Explanation of the second pillar of 5S – Set in order

1.1 Definition of set in order

Set in order means arranging necessary items so that they are easy to use and labelling them so that anyone can find them and put them away. The key word in this definition is “anyone”. Set in order can be implemented only when the first pillar- sort is done first. No matter how well you arrange items, set in order can have little impact if many of the items are unnecessary and not sorted. Similarly, if sorting is implemented without setting in order, it is much less effective. Where necessary items should be placed should be made clear for anyone to immediately find them and return them easily. Hence, Sort and Set in order work best, when they are implemented together.

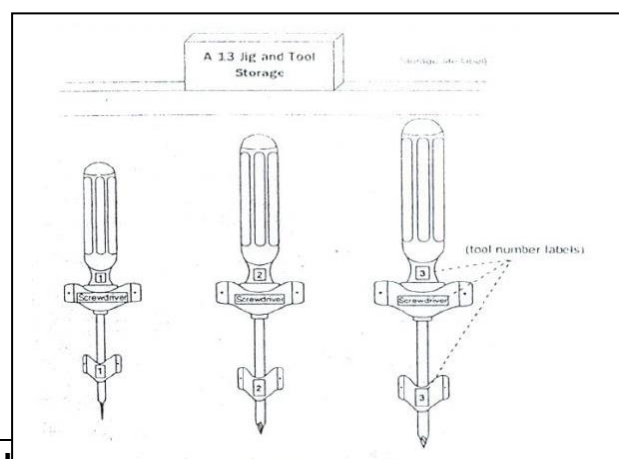

Set in order of tools

1.2 Benefits of set in order

Setting in order is important because it eliminates many kinds of waste from operations in a workplace. These include searching time waste, waste due to difficulty in using items, and waste due to difficulty in returning items. In general, the following problems and wastes are avoided when set in order is well implemented.

1. Motion wastes
2. Searching time wastes
3. The waste of human energy
4. The waste of excess inventory
5. The waste of defective products
6. The waste of unsafe conditions

The set in order step is actually at the core of so many important business principles such as safety, ergonomics, quality, inventory control, productivity, standard work, the visual workplace and employee morale. Also it is the core of standardization. This is because the workplace must be organized before any type of standardization can be implemented effectively. Standardization means creating a consistent way of doing or carrying out tasks. When we think of standardization, we have to think about anyone. For example, machinery standardization means anyone can operate the machinery. Also if we have operation standardization this means anyone can perform the operation. Even for people to get along together, they need to standardize their behaviors, at least to some extent

Set in order is the core of standardization.

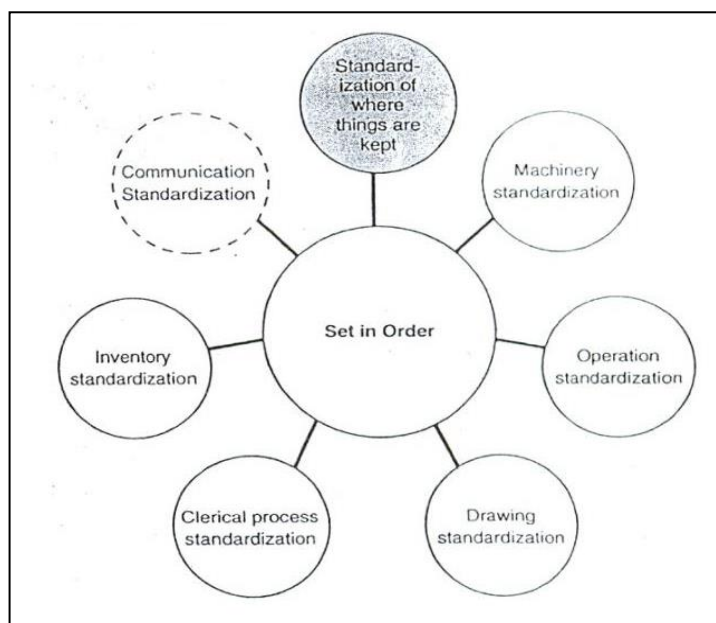

In implementing set in order pillar, we use visual controls so that communications became easy and smooth. For example, we can visually know where items are

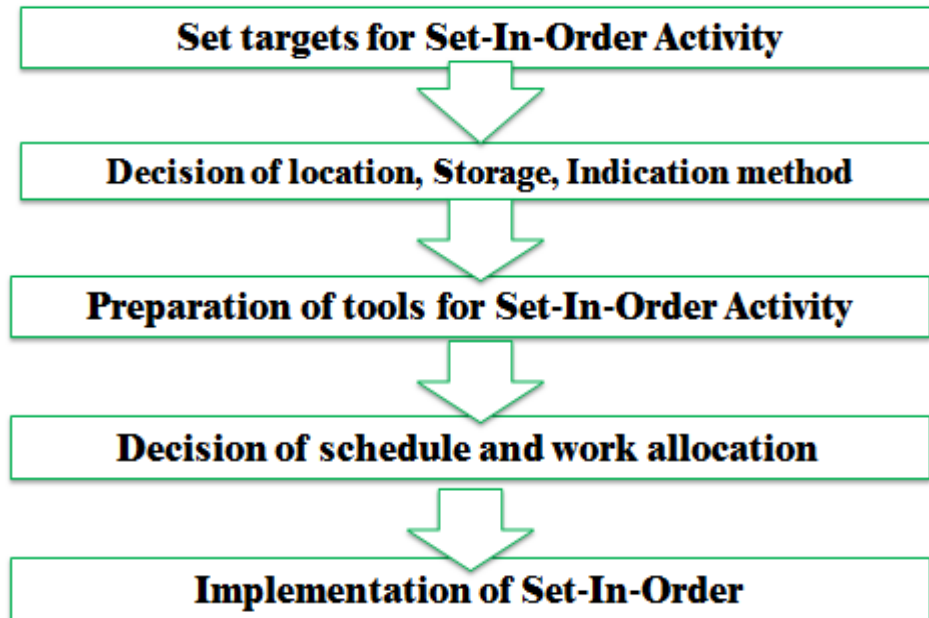

Labels	
Signs	
Figures	
Partition lines	

There are some principles for deciding best locations for tools and equipments. Jigs, tools and dies differ from materials, equipments, machinery and parts in that they must be put back after each use. Some of the principles for jigs, tools and dies also apply to parts, equipments, and machinery. These are:

- Locate items in the workplace according to their frequency of use. Place frequently used items near the place of use. Store infrequently used items away from the place of use.
- Store items together if they are used together, and store them in sequence in which they are used.

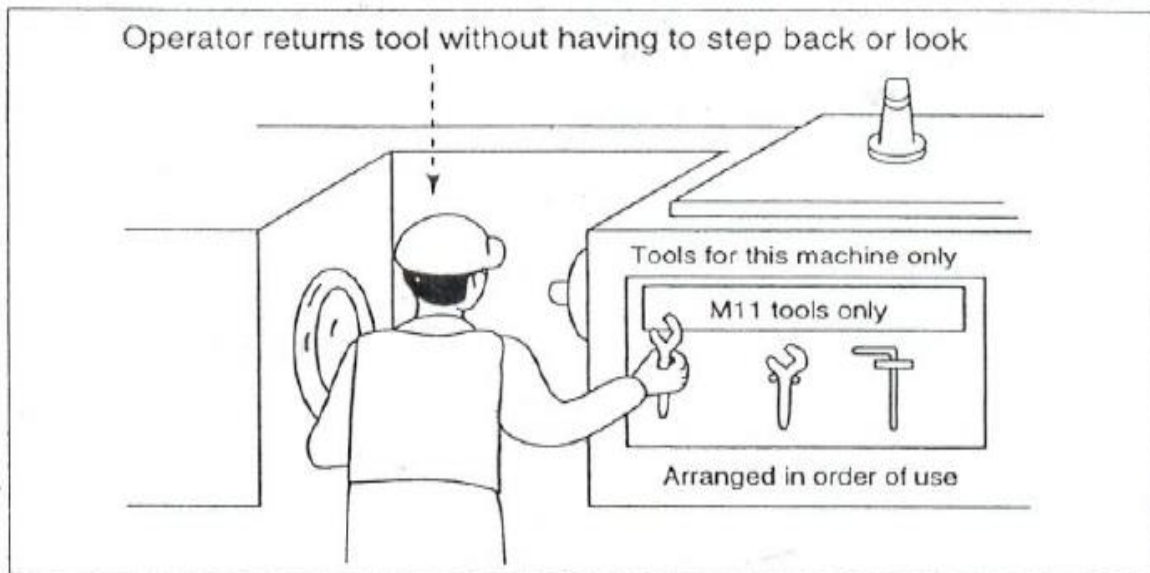

Fig. Tools kept at hand and stored in the order used.

- Device a “just let go” arrangement for tools. This approach involves suspending tools from a retractable cord just within reach so that they will automatically go back in to their correct storage position when released.
- Make storage places larger than the items stored there so that they are physically easy to remove and put back.
- Eliminate the variety of jigs, tools and dies needed by creating a few jigs, tools and dies that serve multiple functions.
- Store tools according to function or product. Function-based storage means storing tools together when they have similar functions. This works best for job-shop production. Product-based storage means storing tools together when they are used on the same product. This works best for repetitive production.

There are principles helpful in deciding the best locations for parts, equipments, and machinery, as well as tools by removing motion wastes. Motion wastes are unnecessary movements created when people move their trunks, feet, arms, and hands more than needed to perform a given operation. These wastes lead to waste of time, energy and effort. These motion wastes can be minimized by locating parts, equipments, and machinery in the best locations possible. More important than removing motion wastes is asking why it occurs. By asking ‘why’ we can find the methods of manufacturing that work and approach the zero-waste mark. Eliminating the unnecessary motions from existing operations is called *Motion improvement*. And finding ways to eliminate the whole operations to remove the wastes is called *Radical improvement*.

The principles that are helpful to eliminate or reduce motions that operators make are:

Principle 1: Start and end each motion with both hands moving at once.

Principle 2: Both arms should move symmetrically and in opposite directions.

Principle 3: Keep trunk motions to a minimum.

Principle 4: Use gravity instead of muscle.

Principle 5: Avoid zigzagging motions and sudden changes in direction.

Principle 6: Move with a steady rhythm.

Principle 7: Maintain a comfortable posture with comfortable motions.

Principle 8: Use the feet to operate on and off switches for machines where practical.

Principle 9: Keep materials and tools close and in front.

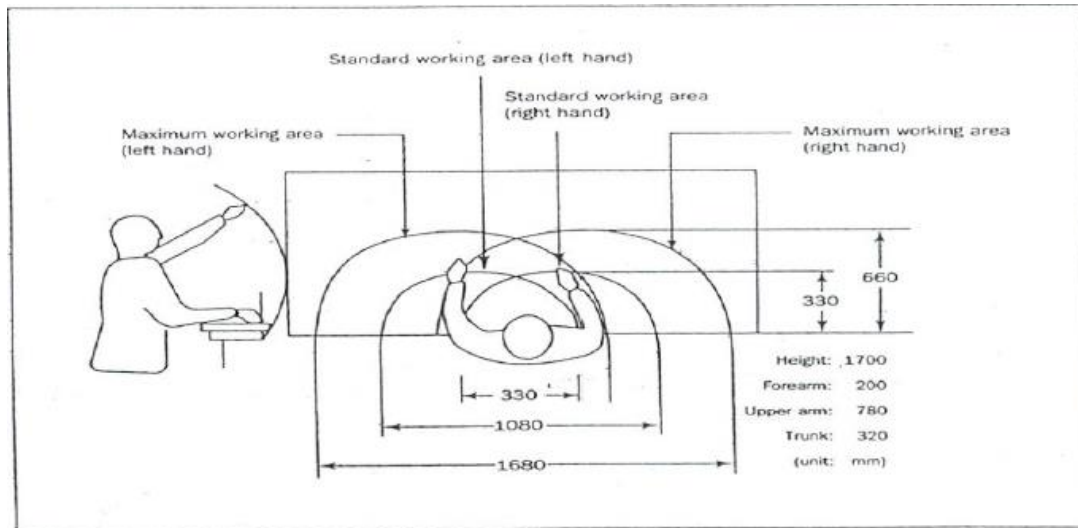

Fig. Guidelines for locating parts, equipments, and machinery to maximize motion efficiency.

Principle 10: Arrange materials and tools in the order of their use.

Principle 11: Use inexpensive methods for feeding in and sending out materials.

Principle 12: Stand at a proper height for the work to be done.

Principle 13: Make materials and parts easy to pick up.

Principle 14: Make handles and grips in efficient, easy-to-use shapes and positions.

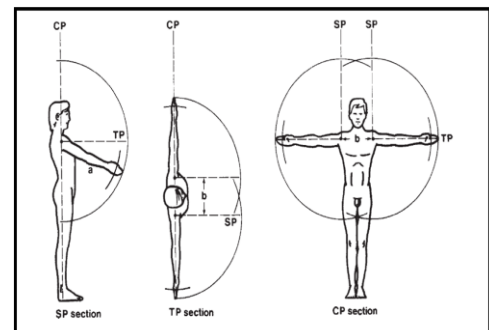
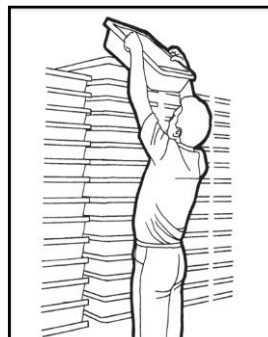
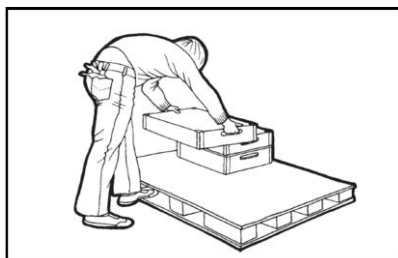

Fig. Motion wastes

Fig. No waste of motion

Example of eliminating motion wastes

Improving the retrieval of parts

The figure below shows an improvement in picking up parts in an assembly work. Before improvement, the worktable was so large that the assembly worker had to stretch to pick up parts. Also, the parts boxes were laid flat at table level, making it

difficult to reach inside them. After improvement, the decreased width of the worktable enabled the assembly worker to reach the parts without stretching his arm too far. Also the parts boxes set on an inclined surface to make their contents more accessible.

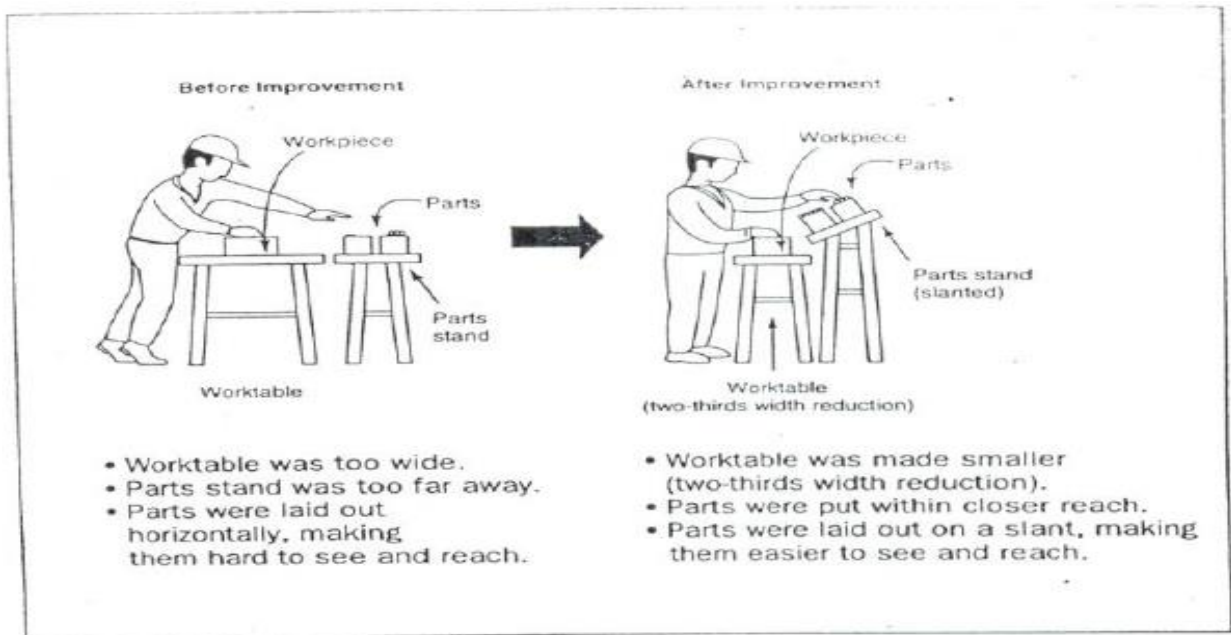

Improvements in picking up parts

Improving the layout of parts

The following figure shows an improvement in how plastic packaging sheets are used. The sheets are moved from a rack behind the operator to a hook in front of the operator and above the production line. This improvement eliminates four seconds of motion waste from each unit of packing work.

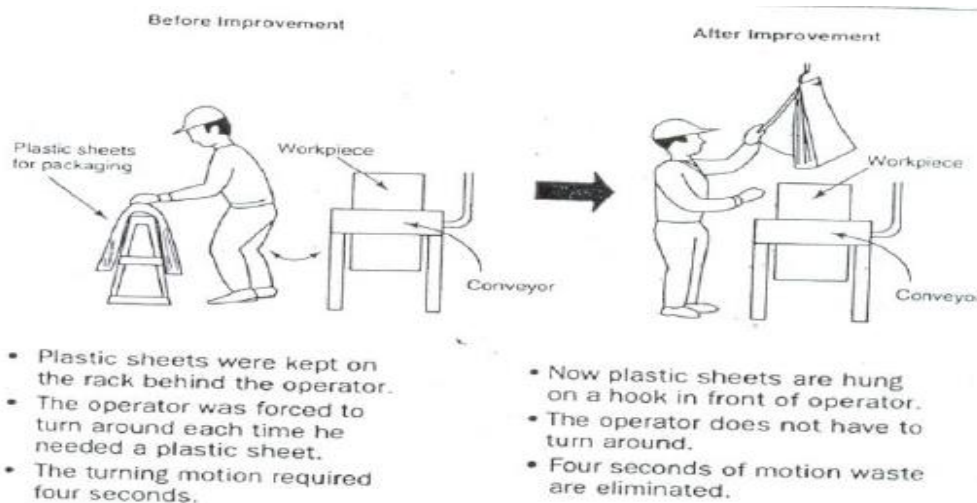

Fig. Improvement in parts layout

Evaluating current locations and deciding best locations

The 5S Map is a tool that can be used to evaluate current locations of parts, jigs, tools, dies, equipment, and machinery, and to decide best locations. 5S Map involves

creating two maps 'before map' and 'after map'. The 'before map' shows the layout of the workplace before implementing set in order. The 'after map' shows the workplace after implementing set in order. The 5S Map can be used to evaluate the locations in a small or large workplaces, like in a single workstations, on a production line, or in a department.

The steps of using the 5S Map:

1. Make a floor plan or area diagram of the workplace you wish to study. Show the location of specific parts, inventory, tools, jigs, dies, equipment and machinery.
2. Draw arrows on the plan showing the work flow between items in the workplace. There should be at least one arrow for every operation performed. Draw the arrows in the order that the operations are performed, and number them as you go.

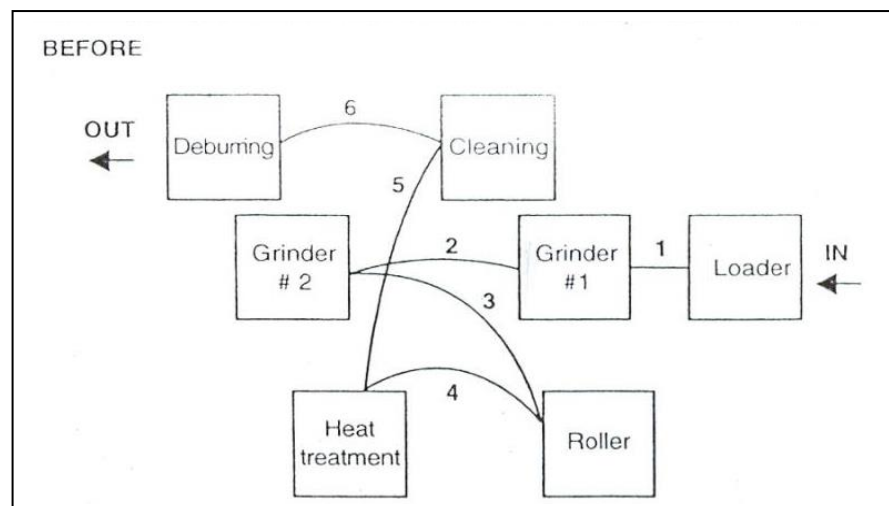

Fig. 5S Map of old layout in machining operations ('before map')

3. Look carefully at the resulting "spaghetti diagram". Can you see places where there is congestion in the work flow? Can you see ways to eliminate waste?
4. Make a new 5S Map to experiment with a better layout for this work place. Again, draw and number arrows to show the flow of operations performed.
5. Analyze the efficiency of the new layout (the after map), based on the principles explained in the above.
6. Continue to experiment with possible layouts (after maps) using the 5S Map until you find one which you think will work well.

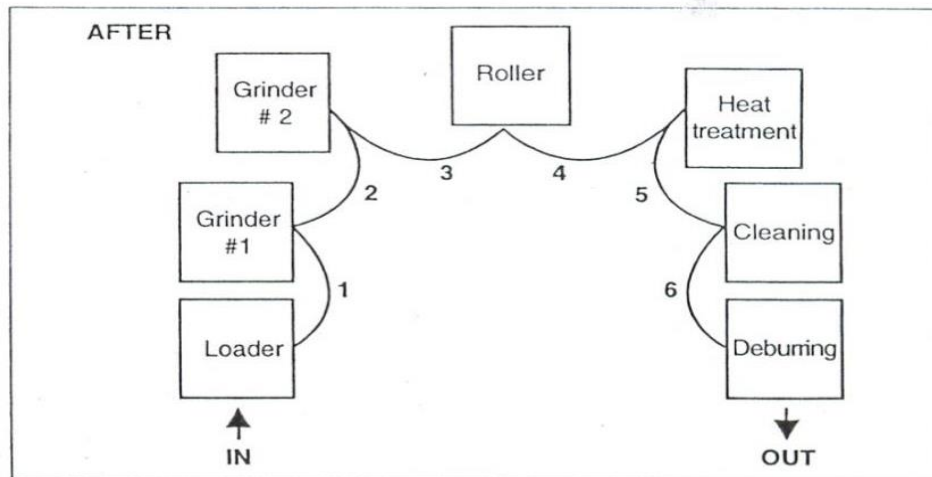

Fig. 5S Map of new layout (the after map) in machining operations.

7. Implement this new layout in the work place by moving parts, tools, jigs, dies, equipment, and machinery to their new locations.
8. Continue to evaluate and improve the layout in the workplace.

2.2 Set in order strategies

Once best locations have been decided, it is necessary to mark these locations so that everyone knows what goes where, and how many of each item belongs in each location. There are several strategies for marking or showing what, where and how many.

2.2.1 Motion Economy strategy

Following the principles explained in the above, we can remove motion waste from existing operation. By using human body appropriately, by organizing the workplace and by redesigning of tools and equipments, we can minimize motion waste.

2.2.2 Visual control Strategy

A visual control is any communication device used in the work environment that tells us at a glance how work should be done. There are several strategies for setting in order items so that to easily identify what, where and how many (visual control). These visual control strategies are discussed in the next contents.

Signboard strategy: uses signboards to identify what, where, and how many. The three main types of signboards are:

- Location indicators that show where items go.
- Item indicators that show what specific items go in those places.
- Amount indicators that show how many of these items belong there.

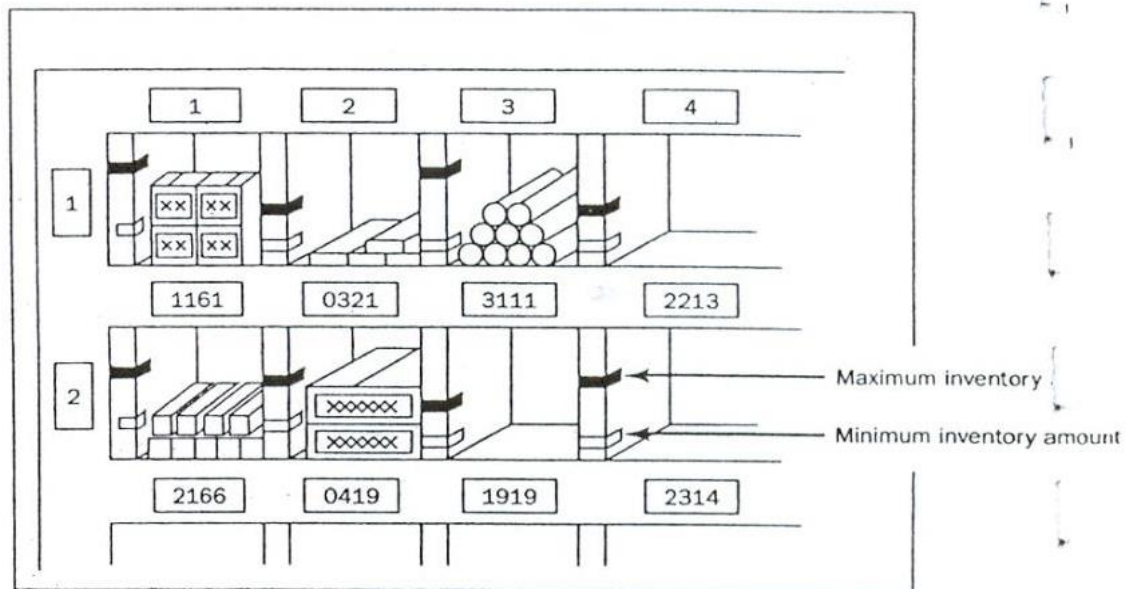

Fig. Amount indicators

Signboards are often used to identify:

- Names of work areas
- Inventory locations
- Equipment storage locations
- Standard procedures
- Machine layout

For example, in order to identify inventory stored on shelves in a warehouse, a whole system of signboards may be used. Every section of shelving may have a signboard identifying the section. Within that section, vertical and horizontal addresses on shelves can be identified with additional signboard. Each item stored on the shelf may also have a signboard showing the “return address” for that item. The “return address” allows the item to be put back in the proper location once it has been removed.

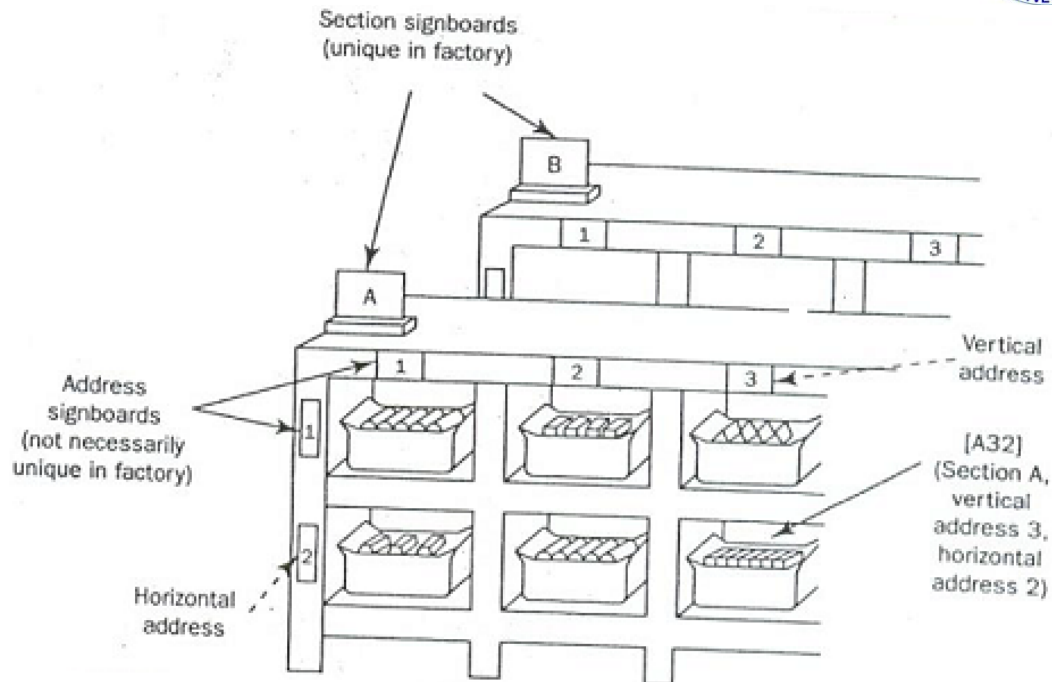

Fig. Location indicators on shelves

The 'after 5S Map' discussed before is a kind of signboard. It shows the location of parts, tools, jigs, dies, equipment, and machinery in a given work area after set in order is implemented. When posted in the work place, it is useful in communicating the standard for where items are located.

Painting strategy: is a method for identifying locations on floors and walkways. It is called the Painting strategy because paint is the material generally used. But also plastic tape, cut in to any length, can be used. Plastic tape, although more expensive, shows up just as clearly as paint and can be removed if the layout is changed.

The painting strategy is used to divide the factory's or workshop's walking areas (walkways) from the working areas (operation areas). When putting lines to divide walkways from operation areas, the following factors should be considered:

- U-shaped cell designs are generally efficient that straight production lines.
- In-process inventory should be positioned carefully for best production flow.
- Floors should be levelled or repaired before we put lines.
- Walkways should be wide enough to avoid twists and turns and for safety and a smooth flow of goods.
- The dividing lines should be between 2 and 4 inches in width.
- Paint colors should be standardized. For example
 - operation areas are painted by green;
 - walkways are fluorescent orange or red;
 - Lines that divide the walkways from operation areas are yellow in color.

Dividing lines can be used to show:

- Cart storage locations,
- aisle directions,
- door range, to show which way a door swings open,
- for worktables,

- Tiger marks, to show areas where inventory and equipment should not be placed, or to show hazardous areas.

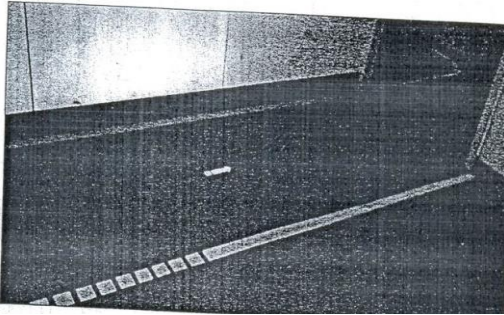

Fig. Aisle direction line

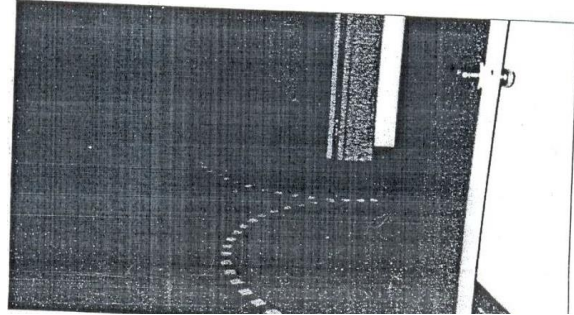

Fig. Door-range line



Color-code strategy : is used to show clearly which parts, tools, jigs and dies are to be used for which purpose. For example, if certain parts are to be used to make a particular product, they can all be color-coded with the same color and even stored in a location that is painted with that color. Similarly, as shown the picture in below, if different types of lubricants are to be used on different parts of a machine, the supply containers, oil cans, and machine parts can be color-coded to show what is used where.

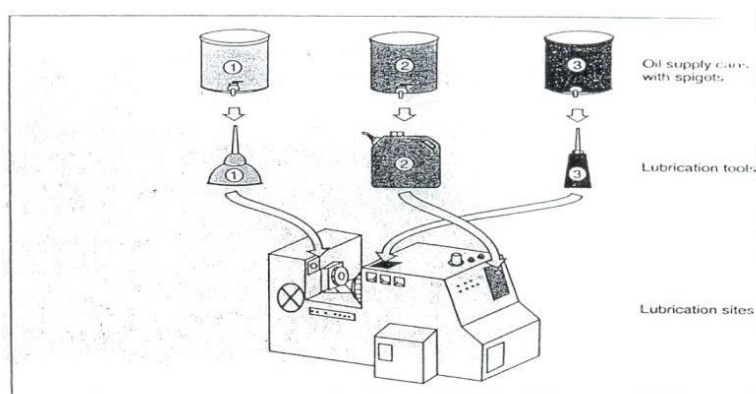
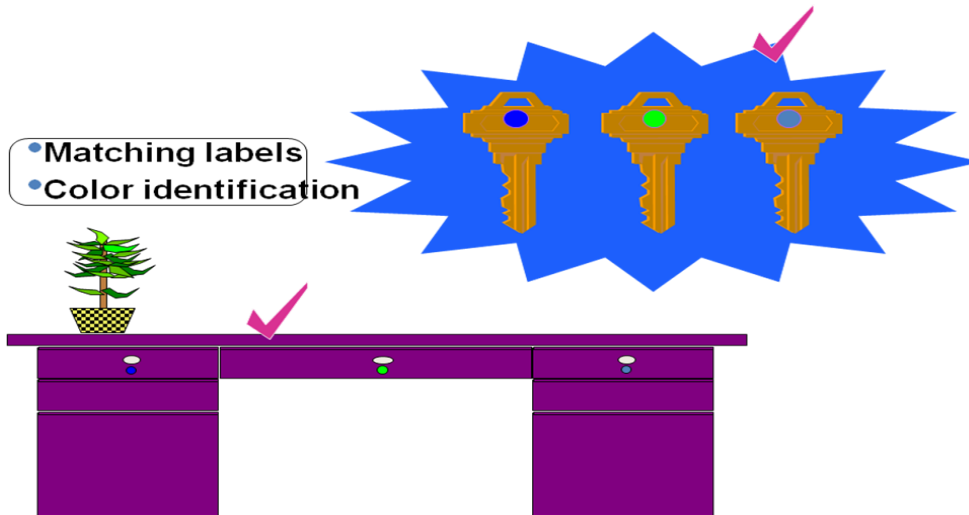
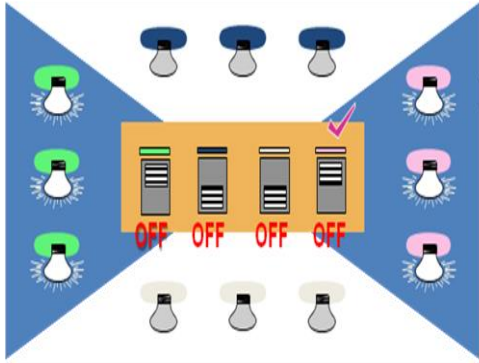

Fig. Color-coding for lubrication



Outlining strategy: is used to show which jigs and tools are stored where. Outlining simply means drawing outlines of jigs and tools in their proper storage positions. When you want to return a tool, the outline provides an additional indication of where it belongs.

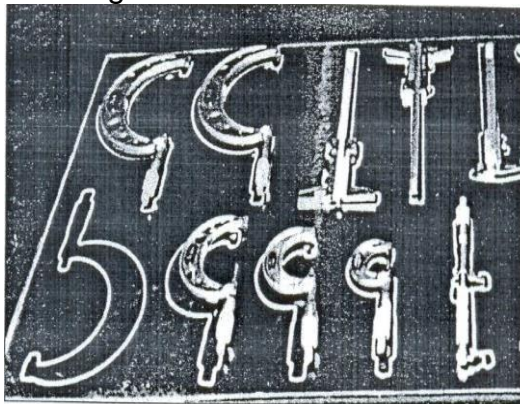

Fig. Outlining of tools to show their locations



Self-Check 1	Written Test
---------------------	---------------------

Instructions: Answer all the questions listed below. Illustrations may be necessary to aid some explanations/answers. Write your answers in the sheet provided in the next page.

11. Give definition of the second pillar of 5S – Set in order. (3 points)
12. What are the benefits of implementing set in order? (4 points)
13. What are the procedures for set in order? (5 points)
14. What are the principles for deciding best locations of tools and equipments? (6 points)
15. What is 5S Map? (2 points)
16. List the steps of using the 5S Map? (4 points)
17. What are the strategies for implementing set in order? (3 points)
18. What factors should we follow when applying the painting strategy? (6 points)
19. What are the three standardized colors used for dividing and marking walkways and operation areas? (3 points)

Note: Satisfactory rating - 20 points Unsatisfactory - below 20 points

You can ask you teacher for the copy of the correct answers.



Answer Sheet

Score = _____

Rating: _____

Name: _____

Date: _____

1. _____

2. _____

3. _____

4. _____

5. _____



6. _____

7. _____

8. _____

9. _____

2. Draw arrows on the plan showing the work flow between items in the workplace. There should be at least one arrow for every operation performed. Draw the arrows in the order that the operations are performed, and number them as you go.

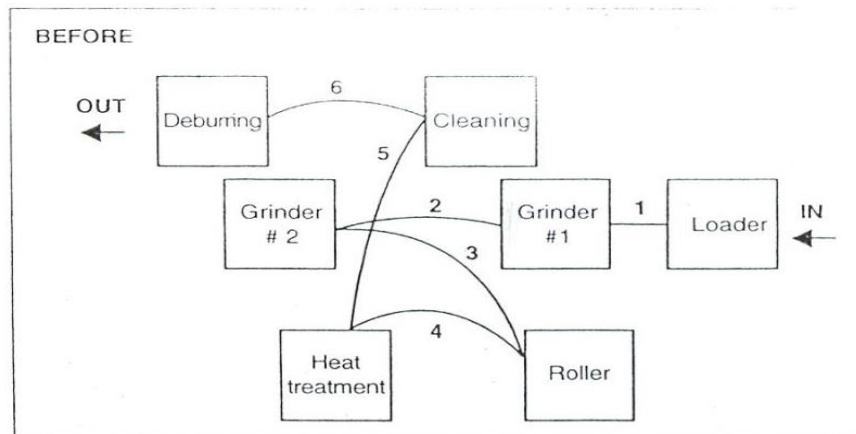

Fig. 5S Map of old layout in machining operations ('before map')

3. Look carefully at the resulting “spaghetti diagram”. Can you see places where there is congestion in the work flow? Can you see ways to eliminate waste?
4. Make a new 5S Map to experiment with a better layout for this work place. Again, draw and number arrows to show the flow of operations performed.
5. Analyze the efficiency of the new layout (the after map), based on the principles explained in the above.
6. Continue to experiment with possible layouts (after maps) using the 5S Map until you find one which you think will work well.

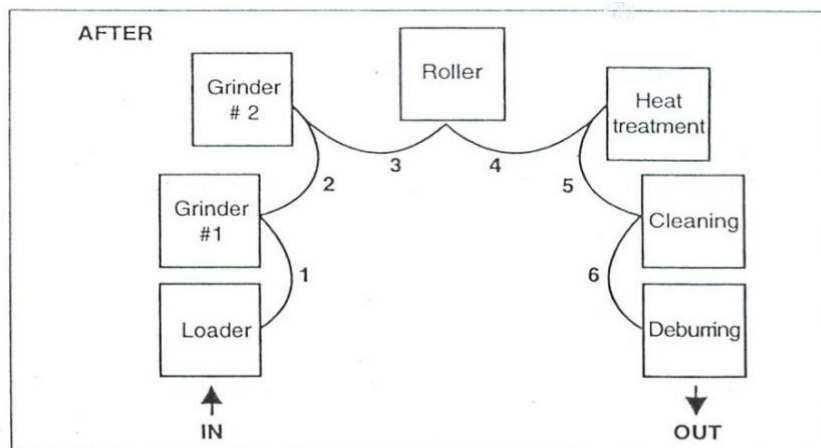

Fig. 5S Map of new layout (the after map) in machining operations

7. Implement this new layout in the work place by moving parts, tools, jigs, dies, equipment, and machinery to their new locations.
8. Continue to evaluate and improve the layout in the workplace.



LAP Test	Practical Demonstration
-----------------	--------------------------------

Name: _____ Date: _____

Time started: _____ Time finished: _____

Instructions: Given necessary templates, workshop, tools and materials you are required to perform the following tasks.

Task 1: Using the given template, prepare a plan for set in order activity in your workshop.

Task 2: Following the steps for using 5S Map, draw before and after map/ layout of your work shop.

Task 3: Following the procedures of set in order, perform set in order in the assigned workshop.



Instruction Sheet

LG09: Perform Shine activities

This learning guide is developed to provide you the necessary information regarding the following content coverage and topics –

- Preparing plan.
- Preparing and using tools and equipment.
- Implementing shine activity.
- Reporting performance results.

Conducting regular shining activities. This guide will also assist you to attain the learning outcome stated in the cover page. Specifically, upon completion of this Learning Guide, you will be able to –

- Prepare plan for implementing shine activities.
- Prepare and use necessary tools and equipment for shine activities.
- Implement shine activity according to the prepared procedure.
- Report performance results using appropriate formats.
- Conduct regular shining activities.

Learning Instructions:

25. Read the specific objectives of this Learning Guide.

26. Follow the instructions described below 3 to 6.

27. Read the information written in the information “Sheet 1, Sheet 2, Sheet 3 and Sheet 4”.

28. Accomplish the “Self-check 1, Self-check t 2, Self-check 3 and Self-check 4” in **page -6, 9, 12 and 14** respectively.

29. If you earned a satisfactory evaluation from the “Self-check” proceed to “Operation Sheet 1, Operation Sheet 2 and Operation Sheet 3” in **page -15**.

30. Do the “LAP test” in **page – 16** (if you are ready).

Information Sheet-1	The third pillar of 5S – Shine
----------------------------	---------------------------------------

3. Explanation of the third pillar Shine

3.1 Definition of Shine

The third pillar of 5S is shine. Shine means sweeping floors, wiping off machinery and generally making sure that everything in the factory stays clean. In a manufacturing company, shine is closely related to the ability to produce quality products. Shine also includes saving labor by finding ways to prevent dirt, dust, and debris from piling up in the workshop. Shine should be integrated in to daily maintenance tasks to combine cleaning checkpoints with maintenance checkpoints.



Fig. Workers shinning machines.



Fig. Workers shinning the floor

Cleaning is so important because when we clean an area, we are also doing some inspection or checking of machinery, equipment, and work conditions. An operator cleaning a machine can find many mal-functions. When a machine is covered with oil, soot, and dust, it is difficult to identify any problems that may be developing. While cleaning the machine, however, one can easily spot oil leakage, a crack developing on the cover, or loose nuts and bolts. Once these problems are recognized, they are easily fixed.

It is said that most machines breakdowns begin with vibration (due to loose nuts and bolts), with introduction of foreign particles such as dust (due to the crack on the cover, for instance), or with inadequate oiling and greasing. For this reason shine is useful to make discoveries while cleaning machines. Hence, shine means cleaning the workplace’s floors, equipment and facilities, provide inspection at the same time, and ensure that they are in good operating condition.

3.2 Benefits of shine

One of the more obvious purposes of shine is to turn the workplace in to clean, bright place where everyone will enjoy working. Another key purpose is to keep everything in top condition so that when someone needs to use something, it is ready to be used. Companies or organizations should avoid the tradition of annual at the end of the year or on spring cleanings. Instead, cleaning should become a deeply ingrained

part of daily work habits, so that tools, equipment, and work areas will be ready for use all the time.



Fig. Workers cleaning machines

Cleanliness for factories and offices is a lot like bathing for human beings. It relieves stress and strain, removes sweat and dirt, and prepares the body and mind for the next day. Cleanliness is important for physical and mental health. Just as you would not bath only once a year, performing shine procedures in a factory should not be an annual activity. Cleaning should be done on daily basis.



Fig. Shine activities relieves stress and strain

Shine activities can play an important part in bringing work efficiency and safety. Cleanliness is also linked with the morale of employees and their awareness of improvements. Factories or workshops that do not implement the shine pillar suffer the following types of problems:

1. Poor morale and inefficiency at work. This could be due to dirty windows that can pass only little light.
2. Unable to see or find defects in dark and messy workplaces.
3. Slipping and injuries can be created due to puddles of oil and water on the floor.
4. Frequent breakdown of machines due to insufficient check-ups and maintenances which in turn leads to late deliveries.
5. Low and unsafe operating machines due to insufficient checkups and maintenance which in turn leads to hazard and accidents.



6. Defects will result due to shaving cuts getting mixed in to production or assembly processes.
7. Shaving cuts can get in to people's eyes and create injuries.
8. Low morale due to filthy work environments.

4. Implementing the third pillar - Shine

4.1 Plan and procedures for shine activities

Shine activities should be taught as a set of steps and rules that employees learn to maintain with discipline. The following sample format can be used to prepare a plan for implementing shine activities.

Shine activity plan sheet (sample)

Preparation date: Year Month Day
Prepared by 5S Committee

Area : M-1

Basic Plan		Seisou Activity																														
		5th month																														
Activity		1	2	3	4	5	6	7	8	9	10	11	12	13	14	15	16	17	18	19	20	21	22	23	24	25	26	27	28	29	30	31
Preparing necessary tools	Plan																															
	Result																															
Determining activity area	Plan																															
	Result																															
Designing procedures for the Seisou Activity	Plan																															
	Result																															
General cleaning	Plan																															
	Result																															
Working out the problems revealed through the general cleaning	Plan																															
	Result																															

Procedures for Set in order

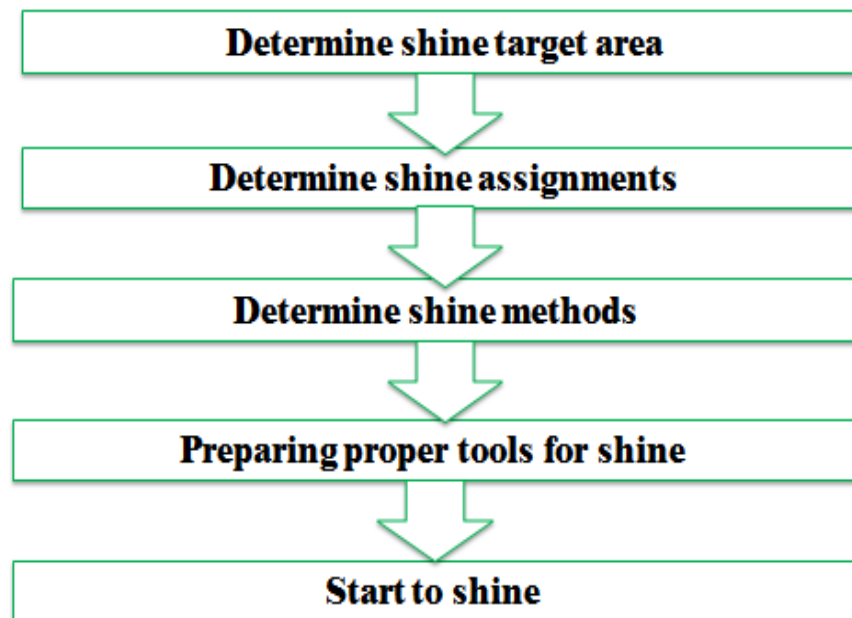

Step 1: Determine shine target areas

Shine target areas are grouped in to three categories: warehouse item, equipments and space. *Warehouse items* include raw materials, procured subcontracted parts, parts made in-house, and assembly components, semifinished and finished products. *Equipment* includes machines, welding tools, cutting tools, conveyance tools, general tools, measuring instruments, dies, wheels and casters, worktables, cabinets, desks, chairs and spare equipment. *Space* refers to floors, work areas, walkways, walls, pillars, ceilings, windows, shelves, closets, rooms and lights.

Step 2: Determine Shine Assignments

Workplace cleanliness is the responsibility of everyone who works there. Each employee should be assigned specific area to clean. To do this two methods can be used:

- A 5S Assignment Map – shows all the target areas for shine activity and who is responsible for cleaning them. By marking on 5S Map, the shine assignments can be shown.
- A 5S schedule – shows in detail who is responsible for cleaning which areas on which days and times of the day. Then this schedule should be posted in the work area.

Example 1:



General Cleaning Assignment Sheet						Date of cleaning: Year Month
Activity area		Target place/object	Group	Leader	Tools	Required number of workers
Zone A	Machining-- Group A area	Lathe	Manufacturing	A	Detergent	25
		Press machine			Waste cloth	
		Floor			Scraper	
	Machining-- Group B area	Resting-place			Broom	
		Pathway			mop	
Zone B	Purchasing area					
	Material area					
Zone C	Painting area					
	Processed products discharge area					

Example 2:

Regular Cleaning Assignment Sheet												
Worksite			Group				5S promoter					
No.	Day	Target place/object	Person in charge						Frequency	Time	Start	Tool
			A	B	C	D	E	F				
1	Mon											
2												
3												
4	Tue											
5												
6												
7	Wed											
8												
9												
10	Thu											
11												
12												
13	Fri											
14												
15												

Step 3: Determine shine methods

Shine activities should be a natural part of the daily work. Shine activities and inspection should be done before a shift starts, during work time and at the end of the shift.

Determining shine methods include:

- *Choosing targets and tools* – define what will be cleaned in each area and what supplies and equipments will be used.
- *Performing the five-minute shine* – cleaning should be practiced daily and should not require a lot of time.
- *Creating standards for shine procedures* – people need to know what procedures to follow in order to use their time efficiently. Otherwise, they are likely to spend most of their time getting ready to clean.

Step 4: prepare tools

The cleaning tools should be placed properly or set in order where they are easy to find, use and return.

Step 5: Start to shine

When implementing the shine procedures, consider the following suggestions:

- Be sure to sweep dirt from floor cracks, wall corners, and around pillars.
- Wipe off dust and dirt from walls, windows, and doors.
- Be thorough about cleaning dirt, scraps, oil, dust, rust, cutting shavings, sand, paint, and other foreign matter from all surfaces.
- Use cleaning detergents when sweeping is not enough to remove dirt.

4.2 Inspection

As discussed earlier, it is natural to do a certain amount of inspection while implementing shine activities. Once daily cleaning and periodic major cleanups become a habit, we can start incorporating systematic inspection procedures in to the shine procedures. Even when equipment in the workplace appears to function normally, it may be developing many problems. Always when machines or other equipment begin to show sign of minor, sporadic malfunctions, the operators not the maintenance people notice it first. Therefore, it is important to consider the operators information about the equipment.

The following types of equipment problems frequently exist in factories:

1. Oil leaks from the equipment on to the floor.
2. Machines are so dirty that operators avoid touching them.
3. Gauge displays and other indicators are too dirty to be read.
4. Nuts and bolts are either loose or missing.
5. Motors overheat.
6. Sparks flare from power cords.
7. V-belts are loose or broken.
8. Some machines make strange noises.

Daily cleaning or inspection can help to find these problems and solve them.



Before shine



After shine

4.2.1 Inspection steps

The steps of inspection and shine procedures are parallel. But the steps of inspection give greater emphasis on the maintenance of machines and equipment. These steps are:

Step 1: Determine inspection targets

The targets for inspection are similar to the targets of shine activities. These include machines, equipments, jigs, dies, cutting tools and measuring instruments.

Step 2: Assign inspection activities

In principle, the people who carry out inspection on a particular machine should be the same people who operate the machine. But most often one person can operate several machines at a time (as in multi-process handling). In this case, it is good to involve line supervisors and group leaders in the inspection duties. Once inspection activities are assigned, they have to be written up on a large signboard for the workshop or on small signboards that are attached to each target machine.

Step 3: Determine inspection methods

First all of the items to be inspected should be listed then an inspection checklist should be prepared based on the listed inspection items. The following shows an example of an inspection checklist.

Mechanism	No.	Point	Main Response			
			Clean	Lubricate	Replace	Restore
Lubrication system 	26.	Is there any dirt or dust in the oil inlets?	<input type="radio"/>			
	27.	Do the oil level indicators show adequate levels?		<input type="radio"/>		
	28.	Can the oil level indicators be clearly seen?	<input type="radio"/>			
	29.	Are there any cracks in the oil tank?	<input type="radio"/>			<input type="radio"/>
	30.	Is the bottom of the oil tank dirty?	<input type="radio"/>			<input type="radio"/>
	31.	Is the oil in the tank dirty?			<input type="radio"/>	
	32.	Is there any oil leakage from the tank or pipe joints?			<input type="radio"/>	<input type="radio"/>
	33.	Are oil levels adequate?		<input type="radio"/>		
	34.	Is the correct type of oil being used?			<input type="radio"/>	
	35.	Is there any clogging in the oil pipes?			<input type="radio"/>	<input type="radio"/>
	36.	Is there any dust or dirt at lubrication sites?	<input type="radio"/>			
	37.	Are the lubrication tools dirty?	<input type="radio"/>			

Table: Sample of inspection checklist

Step 4: Implement inspection

When implementing inspection, use all your senses to detect abnormalities. Inspection is not simply a visual activity. There are some ways to detect abnormalities. These are:

- Look closely at how the machine works and watch for slight defects (e.g. oil leakage, debris scattering, deformation, wear, warping, mold, missing items, lopsidedness, inclinations, color changes).
- Listen closely for changes in the sounds the machine makes while operating (e.g. sporadic sounds, odd sounds).

- Use your nose to detect burning smells or other unusual odours (e.g. burning rubber)
- Touch the machine where it is safe during operation and during downtime to detect deviations from normal conditions (e.g. strange vibrations, wobbling, looseness, excessive heat, shifting).

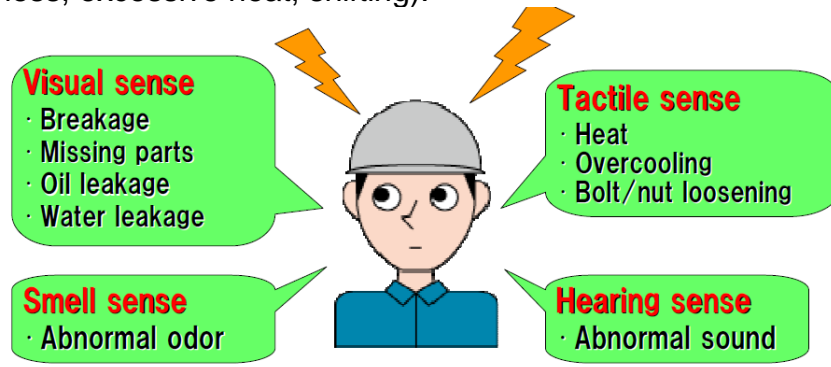

Step 5: Correct equipment problems

All equipment abnormalities or slight defects should be fixed or improved. There are two approaches to do these:

Instant Maintenance: whenever possible, an operator should immediately fix or improve a problem he or she discovers during inspection. But the operators should know what level of maintenance work they can handle by themselves and immediately.

Requested Maintenance: In some cases, a defect or problem may be difficult for the operator to hand alone and immediately. In this situation, the operator should attach a maintenance card to the site of the problem in order to make it visible. He or she can also issue a maintenance kanban to request help from the maintenance department. It is also good to log requested maintenance on to a checklist of needed maintenance activities. Once a requested maintenance is taken care and its result confirmed, the activity should be checked off in the 'confirmation' column of the checklist. The maintenance card should then be retrieved from the machine where it is attached.

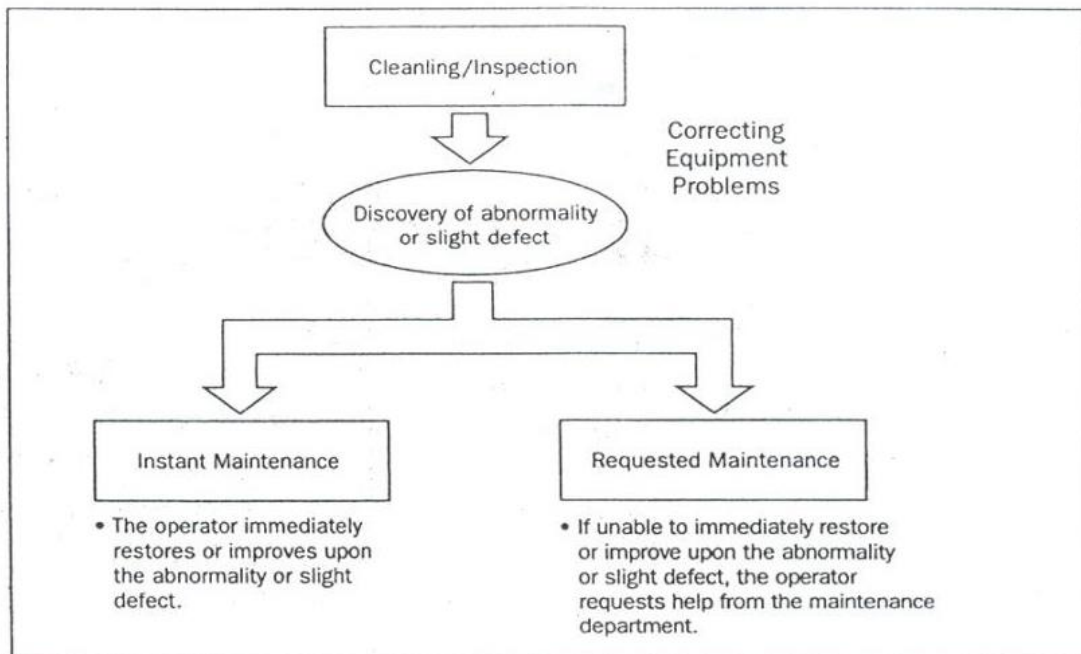

Fig. Two approaches for solving equipment problems

Self-Check 1	Written Test
---------------------	---------------------

Instructions: Answer all the questions listed below. Illustrations may be necessary to aid some explanations/answers. Write your answers in the sheet provided in the next page.

1. Give definition of the third pillar shine. (2 points)
2. What problems occur in a workshop if shine is not implemented? (8 points)
3. What are the steps/procedures for implementing shine? (5 points)



4. What are the two methods used to assign shine activities to employees? (2 points)
5. What are the most frequent problems of equipments/machines? (4 points)
6. List the steps of inspection. (5 points)
7. How do you detect abnormalities in a workplace or machine? (4 points)

Note: Satisfactory rating - 16 points Unsatisfactory - below 16 points
You can ask you teacher for the copy of the correct answers.

Answer Sheet

Score = _____ Rating: _____

Name: _____

Date: _____

1. _____



2.

5.

6.

7.

6.

7.



Operation Sheet 1	Implementing shine activity
--------------------------	------------------------------------

1) Procedures for implementing Shine

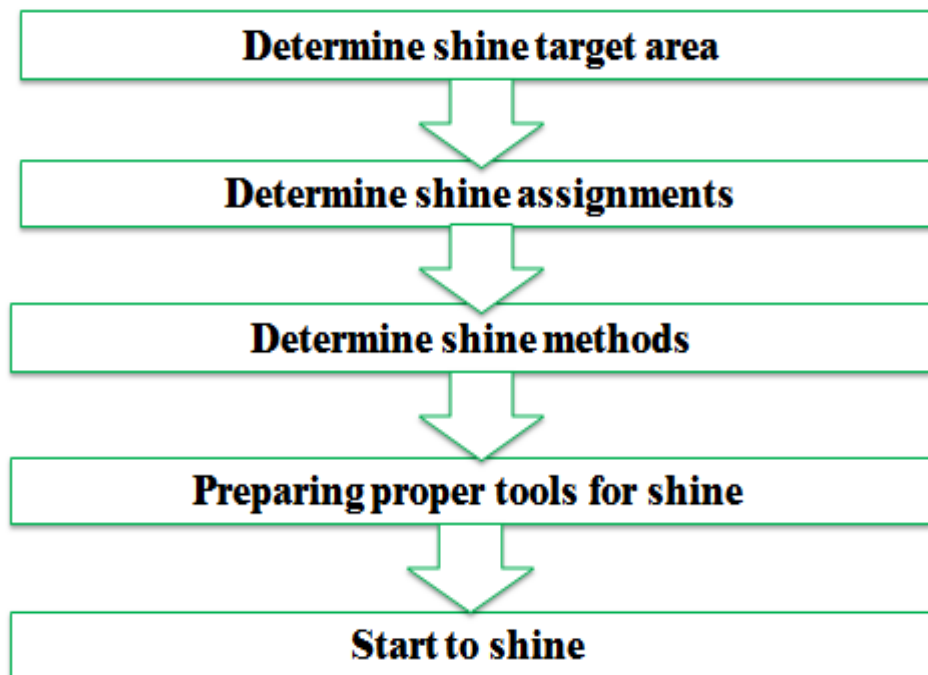

2) Prepare plan for shine

Sample plan for shine

Area : M-1

Preparation date: Year

Month

Day

Prepared by 5S Committee

Basic Plan		Seisou Activity																														
		5th month																														
Activity		1	2	3	4	5	6	7	8	9	10	11	12	13	14	15	16	17	18	19	20	21	22	23	24	25	26	27	28	29	30	31
Preparing necessary tools	Plan	■	■																													
	Result																															
Determining activity area	Plan					■	■	■	■																							
	Result																															
Designing procedures for the Seisou Activity	Plan								■	■																						
	Result																															
General cleaning	Plan												■	■	■	■	■	■														
	Result																															
Working out the problems revealed through the general cleaning	Plan																															
	Result																															

Sample format for general cleaning assignment



General Cleaning Assignment Sheet						
					Date of cleaning: Year Month	
Activity area		Target place/object	Group	Leader	Tools	Required number of workers
Zone A	Machining-- Group A area	Lathe	Manufacturing	A	Detergent	25
		Press machine			Waste cloth	
		Floor			Scraper	
	Machining-- Group B area	Resting-place			Broom	
		Pathway			mop	
Zone B	Purchasing area					
	Material area					
Zone C	Painting area					
	Processed products discharge area					

Sample format for regular cleaning assignment

Regular Cleaning Assignment Sheet												
Worksite			Group						5S promoter			
No.	Day	Target place/object	Person in charge						Frequency	Time	Start	Tool
			A	B	C	D	E	F				
1	Mon											
2												
3												
4	Tue											
5												
6												
7	Wed											
8												
9												
10	Thu											
11												
12												
13	Fri											
14												
15												

3) Steps in inspection

- Step 1: Determine inspection targets
- Step 2: Assign inspection activities
- Step 3: Determine inspection methods
- Step 4: Implement inspection
- Step 5: Correct equipment problems

LAP Test	Practical Demonstration
-----------------	--------------------------------



Name: _____ Date: _____

Time started: _____ Time finished: _____

Instructions: Given necessary templates, workshop, tools and materials you are required to perform the following tasks.

Task 1: Using the given template, prepare a plan for shine activity in your workshop.

Task 2: Following the shine procedures, perform shine activity in the assigned workshop.

Task 3: Following the steps for inspection, perform inspection of equipments, tools and machines in your workshop.







List of Reference Materials

1. KAIZEN: The Key to Japan's Competitive Success (1986)
2. 5S for operators (1995)
3. Ethiopian Kaizen Manual (2011)
4. Journals/publications/magazine



Experts

The development of this Learning Guide for the TVET Program Information technology support service Level I.

No	Name of Trainers	Phone Number	E-mail Address	Region
1	Abdulakim Ahemed	0921900418		Harari
2	Assefa Million	0911034866	amen192005@gmail.com	Harari
3	Derese Teshome	0913938439	dereseteshome@gmail.com	AA
4	Getenesh Osamo	0923816933	gete.osamo@gmail.com	SNNPR
5	Remedan Mohammed	0913478937	remedanm77@gmail.com	Harari
6	Sewayehu W/Yohanes	0911716733	Baroke0816@gmail.com	SNNPR
7	Damelash Yihalem	0911912015	demenati@gmail.com	Harari