

Lecture 5-2

Design of Urban Drainage

Design of Storm water inlets

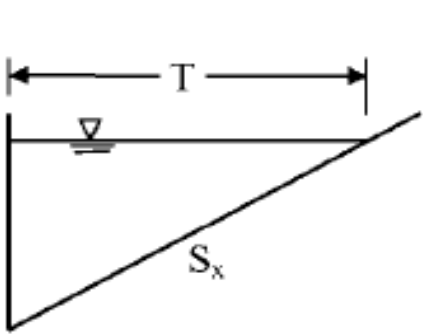
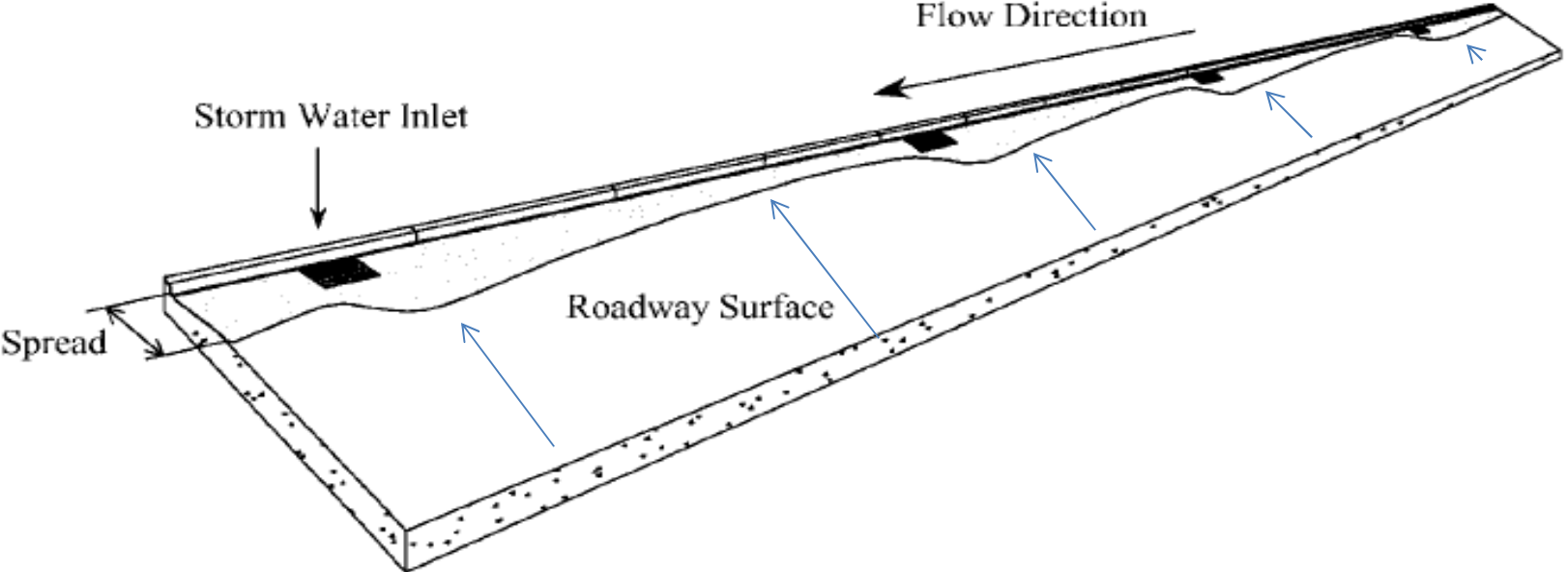

a. Uniform

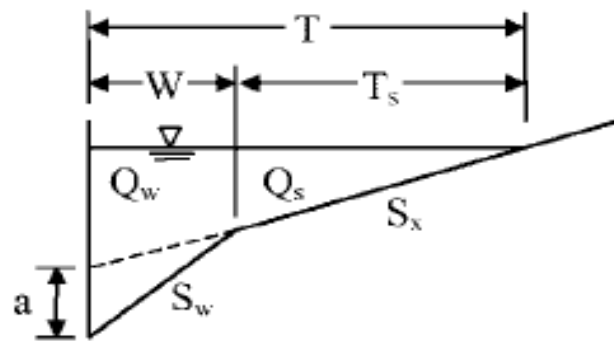

b. Composite

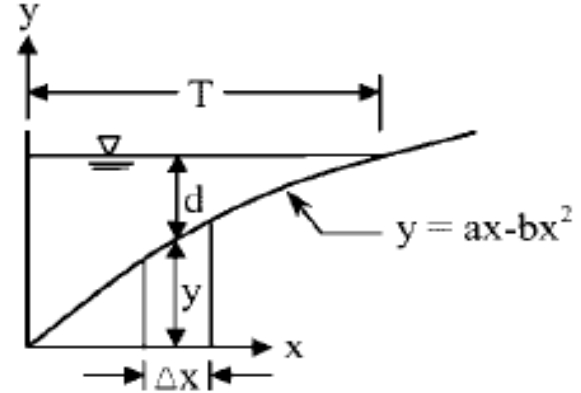

c. Parabolic

FIGURE 5.3 Conventional gutter sections. (Adapted from Brown et al., 1996)

Gutters and inlets

- The objective in highway drainage design is
 - to safely collect runoff from **gutters** and
 - Intercept it using storm water **inlets**
 - Inlets subsequently direct flow to subsurface **conveyance systems, culverts, or ditches.**
 - Proper design of these facilities is thus essential to maintaining safe vehicular and pedestrian travel conditions and ensures that highway service levels will avoid disruption

Gutters and inlets

- The following is a list of key factors that affect spread, and thus require special consideration in specification of inlets:
 - Frequency of the design runoff event and a corresponding rainfall intensity
 - Physical characteristics of the drainage surface, including size, pavement grade or longitudinal slope, lateral cross slope, drainage length, and roughness
 - Physical characteristics of the inlet, including the type of inlet, and its dimensions, capacity, and efficiency
 - Location or spacing of inlets along the drainage surface

Flows in Gutter

1. *Uniform Sections:*

- Uniform gutters have a shallow, triangular cross section,
- The curb forming the near-vertical leg of the triangle, and extend 0.3 to 1 m toward the centerline of the roadway.
- The curb prevents erosion of fill slopes and serves to delineate adjacent property from the highway

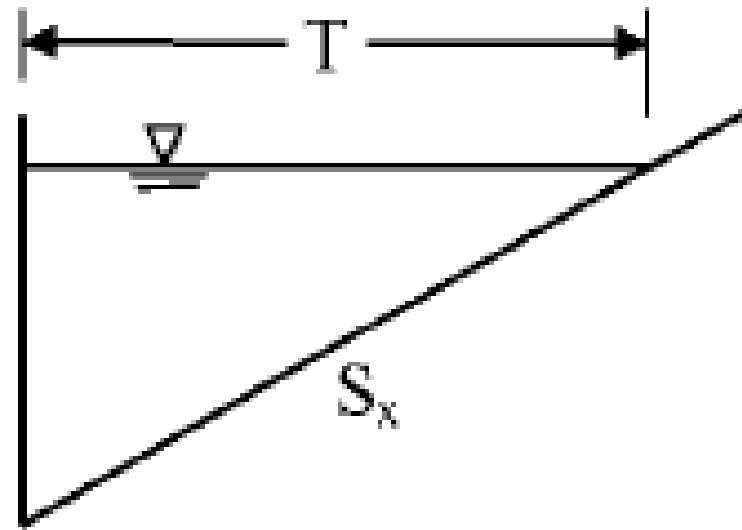

a. Uniform

- Flow could be derived by integrating Manning's equation for an increment of cross-sectional width
- Assuming resistance due to the curb face is negligible, a reasonable assumption for uniform cross slopes less than 10 percent, the integration yields

$$Q = \frac{K_c}{n} S_x^{5/3} S_L^{1/2} T^{8/3}$$

- *Q gutter flow rate in m³/s*
- *K_c empirical constant equal to 0.376 (0.56 in English units)*
- *n Manning's roughness coefficient*
- *S_x gutter cross slope in m/m*
- *S_L longitudinal slope, or grade, of the highway in m/m*
- *T spread of water onto the pavement in m (ft), or top width of flow*

Gutters and inlets

- spread can be related to flow depth at the curb, d ,

$$d = TS_x$$

TABLE 5.3 Manning's Roughness Coefficient for Gutters

Gutter or pavement type	n
Concrete gutter, trowel finish	0.012
Asphalt pavement:	
Smooth	0.013
Rough	0.016
Concrete gutter-asphalt pavement:	
Smooth	0.013
Rough	0.015
Concrete pavement:	
Float finish	0.014
Broom finish	0.016
For gutters with small slope, where sediment may accumulate, increase the above values of n by	0.02

Design example

- Evaluate the spread and depth at the curb for a triangular gutter section carrying a design discharge of 0.09 m³ / s and having a uniform cross slope of 0.022 m/m, Manning's roughness of 0.015, and longitudinal slope of 0.014 m/m.

Solution

Step 1. Compute the spread, T , from Eq. (5.3).

$$T = \left(\frac{Qn}{K_c S_x^{5/3} S_L^{1/2}} \right)^{3/8} = \left[\frac{(0.09)(0.015)}{(0.376)(0.022)^{5/3}(0.014)^{1/2}} \right]^{3/8} = 2.9 \text{ m}$$

Step 2. Determine the depth at the curb, d , from Eq. (5.4).

$$d = TS_x = (2.9)(0.022) = 0.064 \text{ m}$$

Runoff travel time

- *Travel time for flow in gutters is an important aspect of time of concentration used for designing drainage inlets*
- *Assuming flow varies spatially from Q_1 at the beginning of a gutter section to Q_2 at the drainage inlet, the gutter component of time of concentration, t_g , is found by dividing the average flow velocity into the length of gutter section.*

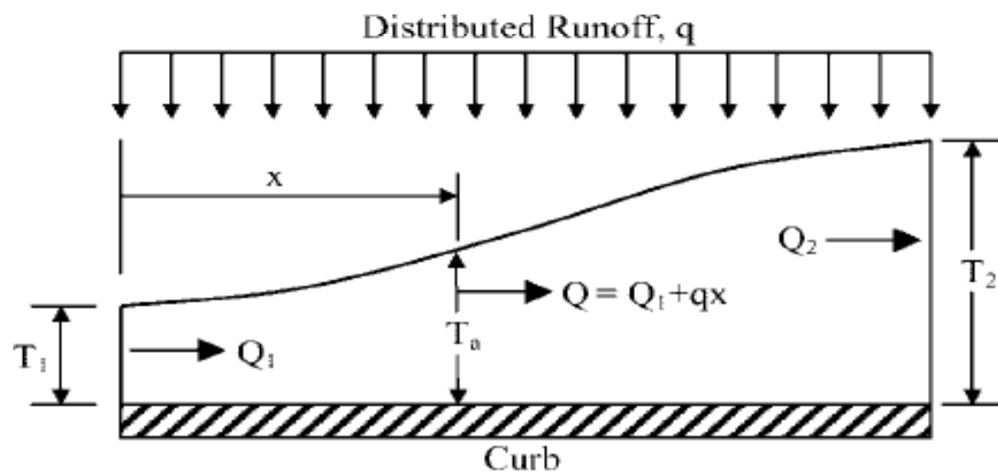

FIGURE 5.5 Spatially varied gutter flow. (Adapted from Brown et al., 1996)

Runoff travel time

The overland flow portion of time of concentration can be computed using the *kinematic wave equation*

$$t_s = \frac{K_c}{i^{0.4}} \left(\frac{nL_s}{\sqrt{S}} \right)^{0.6}$$

Where

- t_s , overland flow component of time of concentration in minutes
- K_c , empirical coefficient equal to 6.943 (0.933 in English units)
- i , rainfall intensity in mm/hr (in / hr) for a duration equal to the time of concentration for overland flow
- N , Manning's roughness coefficient,
- L_s , overland flow length in m
- S , surface slope in m/m
- Note that since rainfall intensity is dependent on t_s , which is initially unknown, solution to this relationship is an iterative process.
- Using an assumed estimate of t_s , the intensity is obtained from regional IDF data.
- The value computed is then compared with the assumed value.
- If they are not equal, the process is repeated until the successive estimates of t_s are the same obtained from regional IDF data
- The value computed is then compared with the assumed value. If they are not equal, the process is repeated until the successive estimates of t_s are the same

Runoff travel time

- The total time of concentration is found by summing the overland flow travel time and gutter flow component

$$t_c = t_s + t_g = \frac{K_c}{i^{0.4}} \left(\frac{nL_s}{\sqrt{S}} \right)^{0.6} + \left(\frac{L_g}{60 V_a} \right)$$

where t_c time of concentration in minutes

V_a average gutter flow velocity in m/s (ft / s)

L_g length of the gutter section in m (ft)

Runoff travel time

- The average gutter velocity is obtained by integrating Manning's equation with respect to time and distance.
- For a triangular, curbed gutter section, the resultant can be expressed as

$$V_a = \frac{K_m}{n} S_x^{2/3} S_L^{1/2} T_a^{2/3}$$

where V_a = average velocity in m/s (fps)

K_m = empirical constant equal to 0.752 (1.12 in English units)

T_a = spread in m (ft) at the average velocity, which can be evaluated by

Runoff travel time

$$T_a = (0.65)(T_2) \left[\frac{1 - \left(\frac{T_1}{T_2}\right)^{8/3}}{1 - \left(\frac{T_1}{T_2}\right)^2} \right]^{3/2}$$

- where T_1 and T_2 are the spread at the upstream and downstream ends of the gutter section being evaluated, respectively, in m

Example 2

- Using the partial intensity-duration-frequency data below, determine the time of concentration for a storm water inlet draining an area of short grass prairie ($n=0.15$) flowing to a 150-m long triangular gutter section. The overland flow length and slope for the grassland are 200 m and 0.036 m/m, respectively. The gutter section has a cross slope of 0.025 m/m, Manning's roughness of 0.016, and a longitudinal slope of 0.020 m/m. Assume that the spread at the upstream end of the gutter section is 0.80 m, as a result of upstream bypass flows, and the design spread at the downstream inlet is 3.0 m.

Duration (min)	Rainfall intensity (mm/hr)
10	147
20	112
30	88
40	72
50	60

Solution

- Step 1. Determine the overland flow portion of time of concentration.
 - a. Assume t_s 10 minutes
 - b. From the IDF data, rainfall intensity is 147 mm/hr at a duration of 10 minutes
 - c. Compute t_s from Eq. (5.13)

$$t_s = \frac{K_c}{i^{0.4}} \left(\frac{nL_s}{\sqrt{S}} \right)^{0.6} = \frac{6.943}{(147)^{0.4}} \left(\frac{(0.15)(200)}{\sqrt{0.036}} \right)^{0.6} = 19.7 \text{ mins}$$

- d. Since the assumed and computed values are not equal, repeat steps a through c with an assumed t_s 19.7 minutes. The following table summarizes the convergence upon the actual value of 22.4 minutes.

Assumed t_s	Rainfall intensity (mm/hr)	Computed t_s
10	147	19.7
19.7	113	21.9
21.9	107	22.3
22.3	106	22.4 (OK)

Solution

Step 2. Compute the gutter flow portion of time of concentration.

a. Evaluate the average spread using Eq. (5.16).

$$T_a = (0.65)(T_2) \left[\frac{1 - \left(\frac{T_1}{T_2}\right)^{8/3}}{1 - \left(\frac{T_1}{T_2}\right)^2} \right]^{3/2} = (0.65)(3.0) \left[\frac{1 - \left(\frac{0.80}{3.0}\right)^{8/3}}{1 - \left(\frac{0.80}{3.0}\right)^2} \right]^{3/2} = 2.08 \text{ m}$$

b. Determine average velocity in the gutter by Eq. (5.15).

$$V_a = \frac{K_m}{n} S_x^{2/3} S_L^{1/2} T_a^{2/3} = \frac{0.752}{0.016} (0.025)^{2/3} (0.02)^{1/2} (2.08)^{2/3} = 0.93 \text{ m/s}$$

c. Calculate the gutter travel time

$$t_g = \frac{L_g}{60 V_g} = \frac{150}{60(0.93)} = 2.69 \text{ mins}$$

Step 3. Compute the total time of concentration by summing the overland flow and gutter flow components, or

$$22.4 + 2.69 = 25.1 \text{ mins}$$

Inlet Design

- Highway drainage inlets and locations, spacing

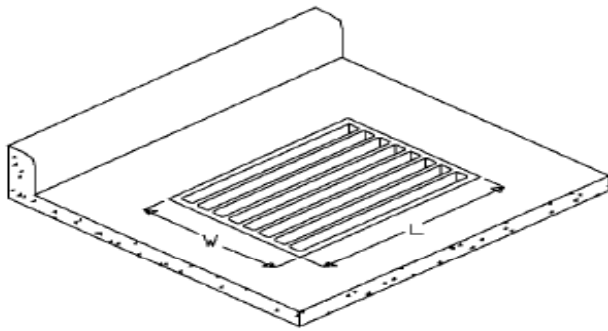

a. Grate

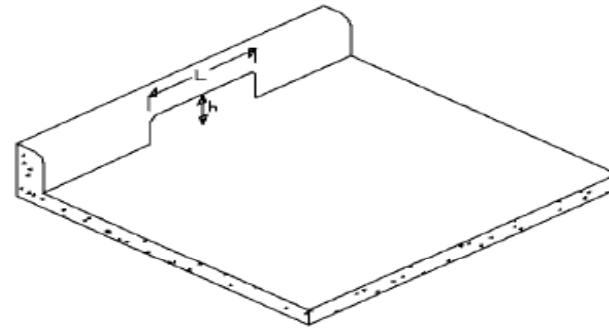

b. Curb-Opening

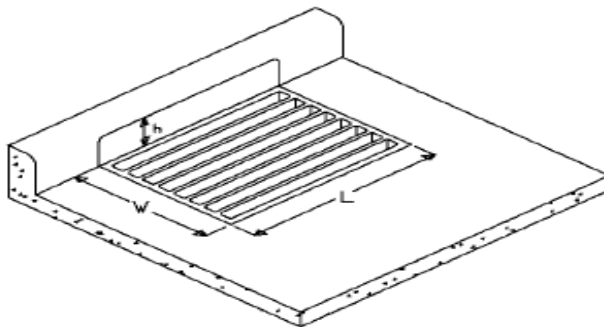

c. Combination

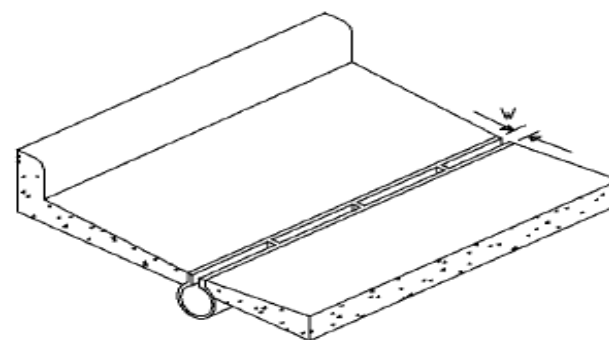

d. Slotted Drain

Design Assignment

1. Embankment inlets and Design of detention system
2. Bridge deck drainage and Design of culvert
3. Design of infiltration basins
4. Highway drainage inlets and locations, spacing