

Food packaging

Dr. Gyimes Ernő- Dr. Szabó P.
Balázs

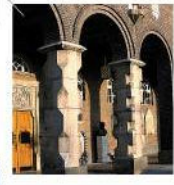

TÁMOP-4.1.1.C-12/1/KONV-2012-0014

SZÉCHENYI 2020



MAGYARORSZÁG
KORMÁNYA

Európai Unió
Európai Szociális
Alap



BEFEKTETÉS A JÖVŐBE

Some type of food packaging

- Flexible food packaging: bags, bottle, pouch, sachet, tube, etc.
- Semi rigid packaging: boxes, plastic bottle, etc.
- Rigid wall packaging: hamper, case, bottle, can, etc.

Other classification principle

- According to barrier feature:
- Barrier packaging
- Porous structure

Packaging materials

- Natural source
- Artificial
- Flexible
- Rigid

Typical packaging materials

- Paper
- Metal
- Glass
- Wood
- Textile
- Plastic
- Combined

Behaviour of paper packaging

Advantages

- Light
- Easy to print
- Easy to fold
- Cheap
- Environmentally friendly
- Easy to recycling

Behaviour of paper packaging

Disadvantages

- Easy to burn/flammable
- Weak sealing
- Release the water vapour
- Sensitive to moisture
- Weak mechanical resistance

Paper packaging - flexible

- Bag
- Sacks

Paper packaging - rigid

- Boxes
- Display



Glass packaging



Glass containers - materials

- Glass containers are commonly made with a combination of various oxides or oxygen-based compounds and are commonly referred to as “soda-lime” glass.
- Raw materials:
 - Sand
 - Soda ash
 - Limestone
 - Cullet
- The goal is to use the most economical and high-quality raw materials available. Some oxides will form glass without adding any other elements and are known as network formers. The most common of these is silica (SiO_2).

Glass containers - colour

- Colour can distinguish a glass container, shield its contents from unwanted ultraviolet rays or create variety within a brand category.
- Colour can be obtained by simply adding small quantities of different oxides:
 - Chromium (for green)
 - Cobalt (for blue)
 - Nickel (for violet/brown)
 - Selenium metal (for red)



Colour of glass - amber

- Amber is the most common colored glass, and is produced by adding together iron, sulfur, and carbon.
- Amber glass absorbs nearly all radiation consisting of wavelengths shorter than 450 nm, offering excellent protection from ultraviolet radiation.



Colour of glass - blue



- Blue glass is created by adding cobalt oxide, a colorant so powerful that only a few parts per million is needed to produce a light blue color such as the shade used for certain bottled waters.
- Creating a reduced blue is seldom done because of the degree of difficulty in fining the glass and controlling the color.
- Most colored glasses are melted in glass tanks, the same method as flint glasses. Adding colorants to the forehearth, a brick lined canal that delivers glass to the forming machine of a flint glass furnace, produces oxidized colors.

Colour of glass - green

- Green Glass is made by adding non-toxic Chrome Oxide (Cr^{+3}); the higher the concentration, the darker the color.
- Reduced green glass offers slight ultraviolet protection.



Some type of glass for packaging

- Bottles
- Jars
- Containers
- Jugs

Closures

A container that is **sealed** totaly protect from entrance of gases, vapors, microorganisms, liquids, dust, etc.

- Essential for vacuum and pressure packaging
- Examples include metal cans and bottles
- Flexible packages are rarely hermetic.

Behaviour of steel packaging

Advantages

- The mechanical strength of steel packaging guarantees its lasting durability
- Total barrier properties against light, gases and liquids, ensure product quality and brand performance
- Food packed in steel has equivalent vitamin content to freshly prepared, without needing preserving agents
- A wide range of dispensing options can be used to suit the function of the product
- From food to chemical products, steel for packaging offers unrivalled efficiency, safety and performance
- Steel offers unique shaping, embossing and printing opportunities
- Steel packaging is available in a wide variety of shapes and sizes, offering brands a complete product range for every context (single household, families, etc)
- Steel packaging provides a wide range of opening and dispensing solutions to suit all product and consumer needs

Behaviour of metal packaging

Disadvantages

- Heavy
- Relatively higher cost (compared with eg. plastic) due to more density
- Higher cost of transportation of empty containers

Metal packaging



Main type of metal packaging

Containers	Closing items	Other
Cans	Roll on/Screw caps	Foils (like aluminium foils)
Beverage cans	Crown caps	Metal layer
Drums	Twist off caps	Trays
Kettle	Press on twist of (PT)	

Type of metals

- In the food sector there are strict rules of applicable materials (metal poison, heavy metal trace, etc,)
- Aluminium (cans, containers, closures)
- Steel/Iron (cans, closures, drums)

Food cans

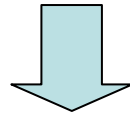

Two pieces and tree pieces can are exist.

Three vs. Two pieces can

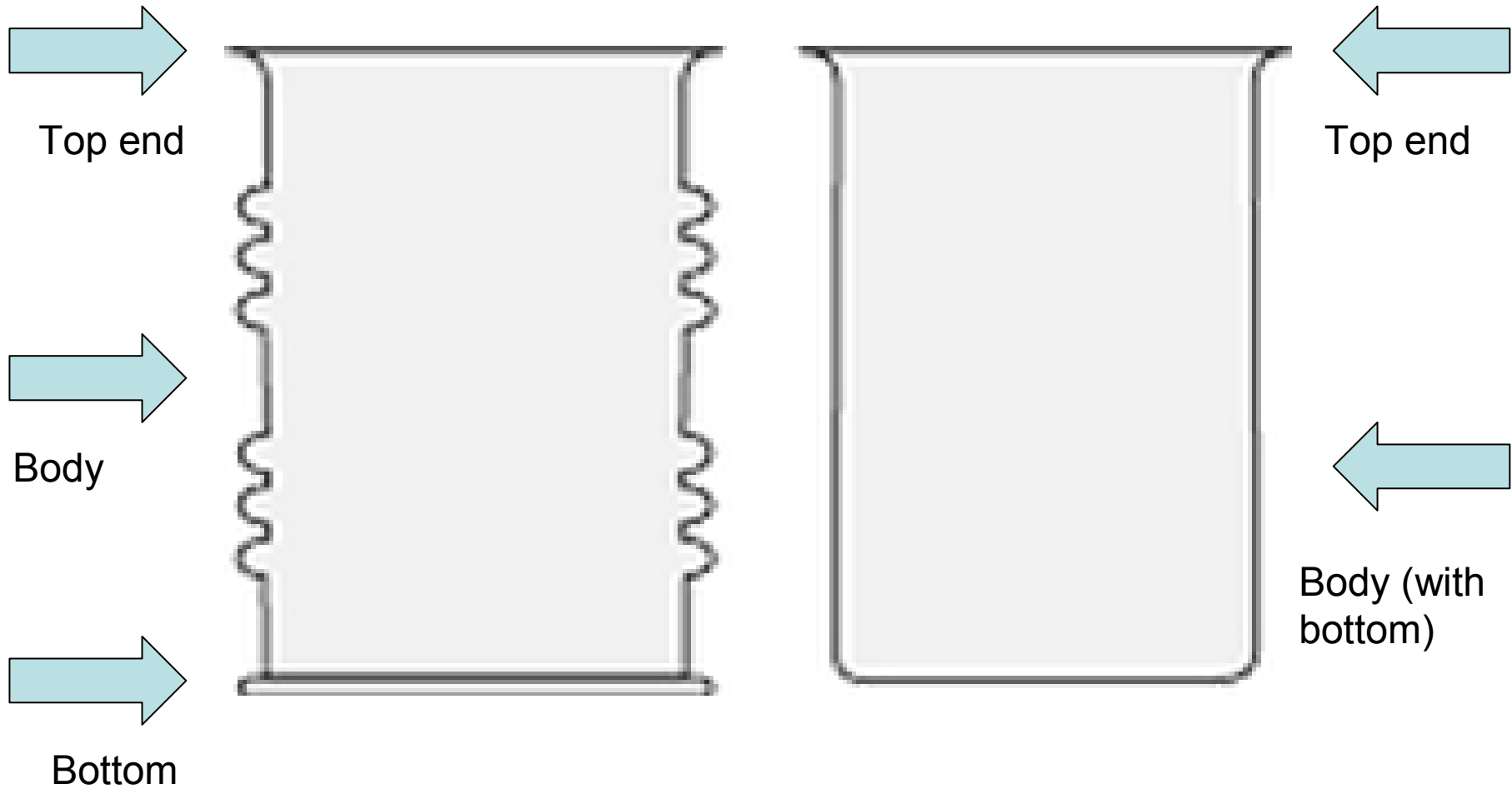

Structure of food can (welded)

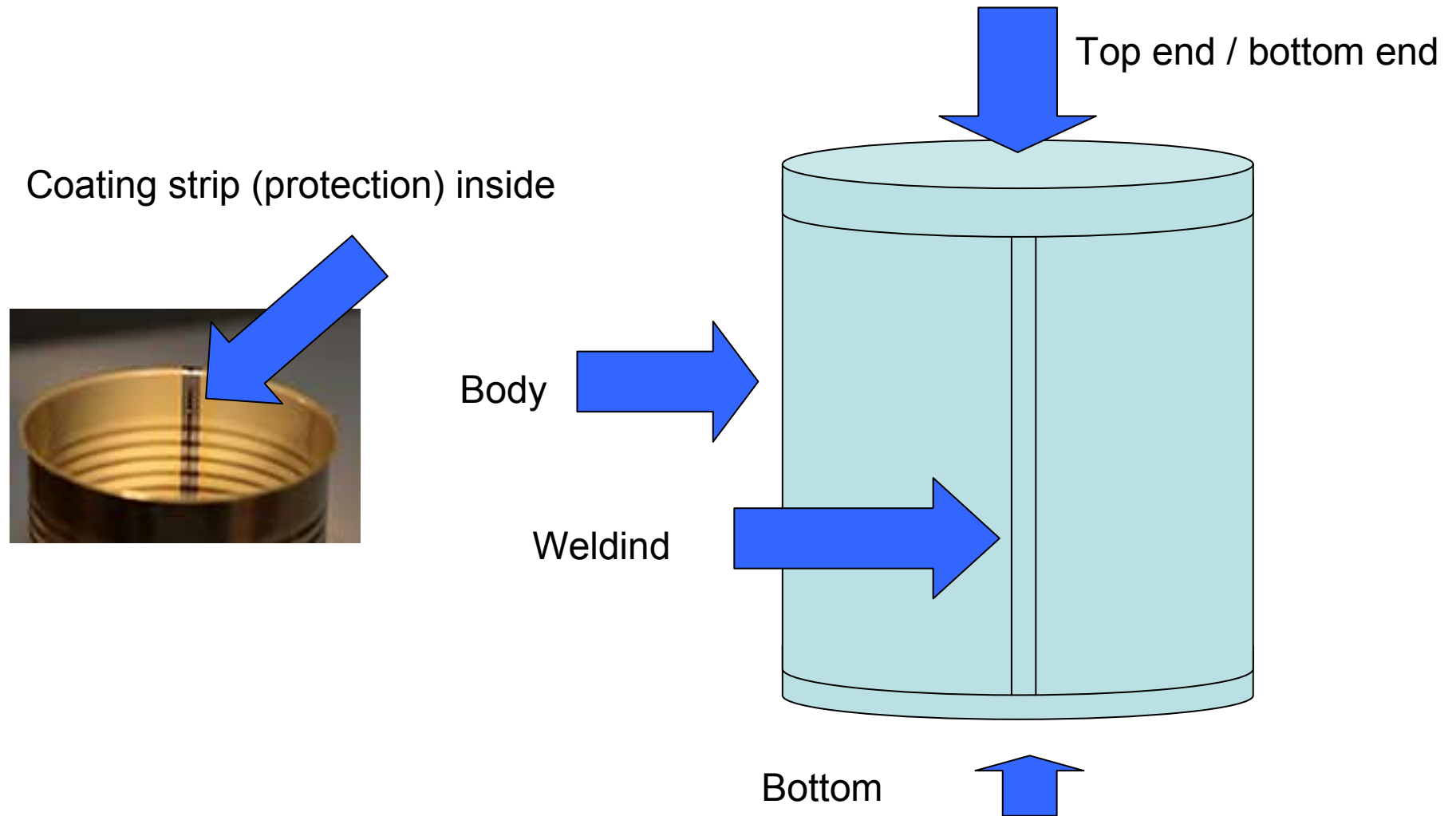

3 pieces welded can

- It has three elements: a welded body, and can ends at bottom and top.
- The body is cut from a rectangular blank which maximizes material use, and the ends are cut from smaller circular blanks to limit scrap.
- The base of the can may be necked slightly for stackability and beads – concentric ridges - on the body are provided to prevent implosion during the early stage of the retorting process.
- Circular beads in the end panel provide for expansion during the later stage of the retort process.
- Double seams on the top and bottom give additional stability.
- The typical line speed is 500 cans a minute.

2 pieces can

- Drawn and Ironed (D&I) or Drawn and Wall Ironed (DWI)
- Faster than 3 pieces welded can (2,500 cans per minute) producing
- The can is made from a disc, then drawn into a low cup of final diameter, which is wall ironed (reduction through compression) to form a high can body.
- The top end is a separate component (put after filling).
- Beads on the body and ends provide strength and flexibility to withstand pressure differences during retort/cooking.



End plates - bottom ends



Common



Easy-to-peel



Eazy-to-open

Aluminium beverage cans

Every year approximately 280 billion beverage cans are manufactured worldwide, and more than 85 percent of them are made from aluminum.

Types:

- Standard
- Slim
- Sleek
- Special (eg, bottle)



Type of beverage can

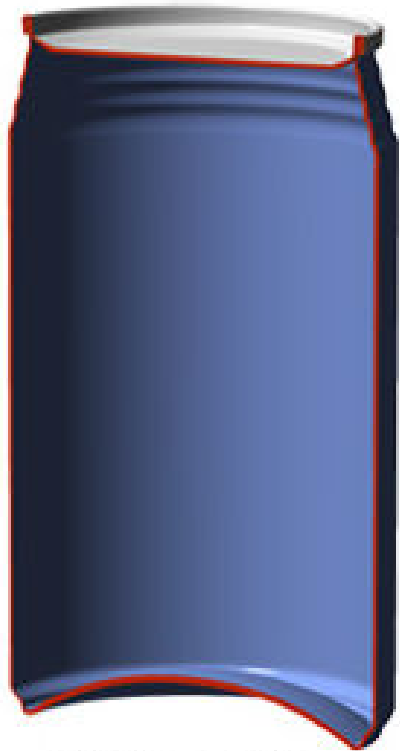

2 Piece Can

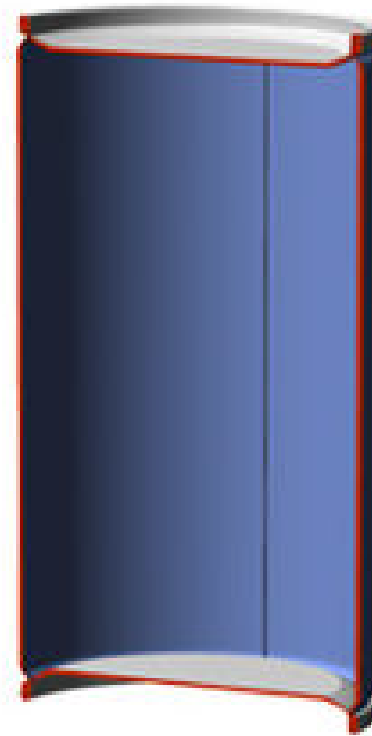

3 Piece Can

<http://www.toyo-seikan.co.jp/e/technique/can/kind/>

Beverage Cans

- **53mm Body Diameter**

8.3oz (250ml)

8.1oz (240ml)

6.0oz ((180ml)

5.5oz (163ml)

5.1oz (150ml)

- **58mm Body Diameter**

9.1oz (269ml)

10oz (296ml)

10.1oz (310ml)

11.3oz (330ml)

12oz (355ml)

- **60mm Body Diameter**

10oz (296ml)

8.3oz (250ml)

- **66mm Body Diameter**

18.6oz (550ml)

16.9oz (500ml)

16oz (473ml)

14.9oz (440ml)

12.7oz (375ml)

12oz (355ml)

11.3oz (330ml)

10.1oz (300ml)

8oz (237ml)

Aluminium can body forming

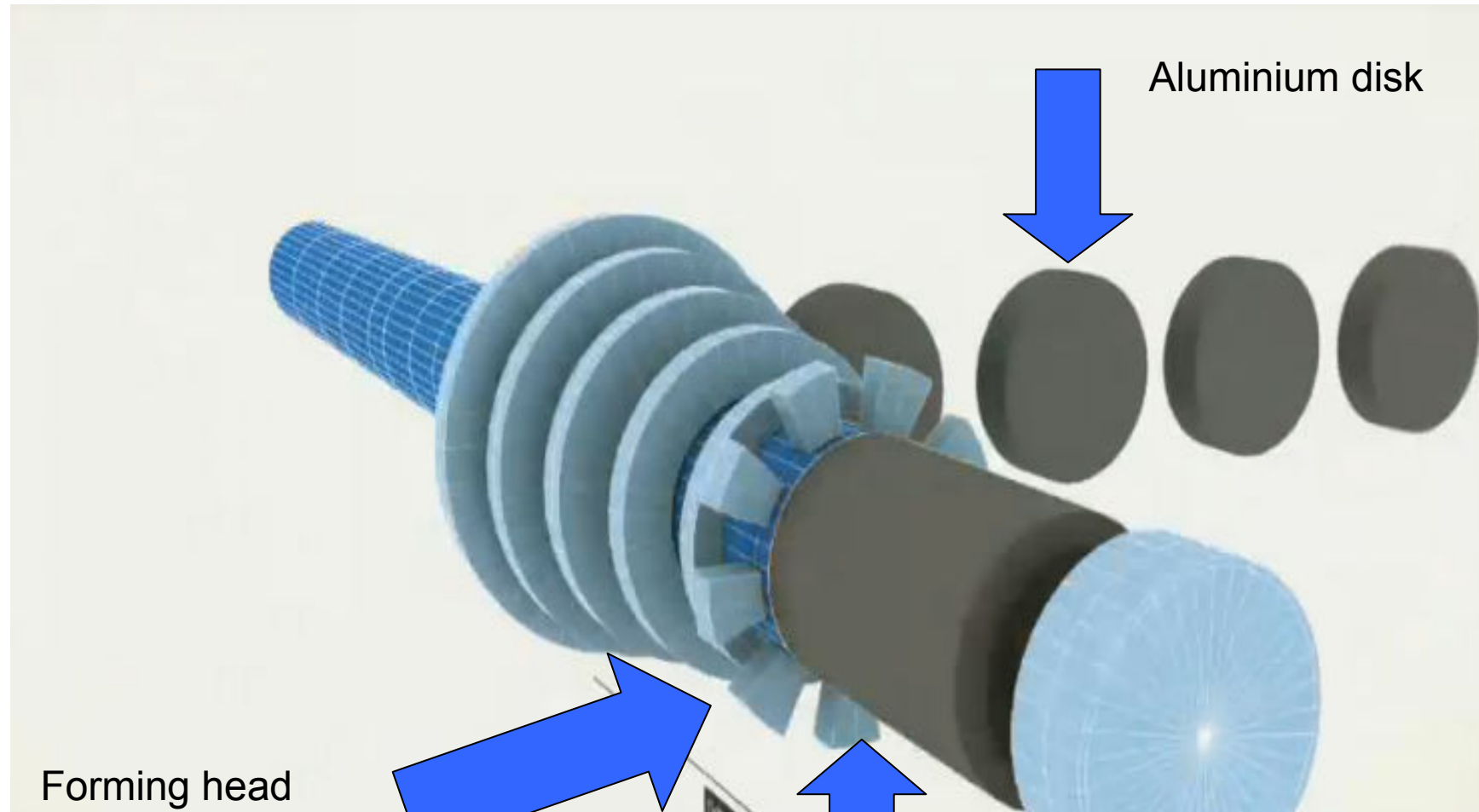

<http://www.rexam.com/index.asp?pageid=450>

Pressed can



The draw-redraw (DRD) steel can

Two-piece Draw-Redraw cans, usually with a ring pull opener, are commonly used to can food. In this method, a cup is stamped or drawn out of a disc of tinplate.

This cup is then redrawn, trimmed and flanged to form the finished can. The cup has no separate bottom end, no side seam and, after lacquering, is ready for the canner to seal with an end.



The necked-in can

The development of the 'necked-in' can has been a recent innovation that has been strongly welcomed by both households and retailers. This can features a slightly wider top end in comparison to the necked in bottom end, making it easier to stack in the pantry at home and easier to stack on supermarket shelves.



The peelable foil end steel can

An innovation in food can manufacture is a can with a foil end that is easy to peel open.

The peelable foil end leaves non-sharp edges after opening, which makes the end particularly safe after opening and has excellent product-resistance qualities. So far this can has been used only for packing 140g fruit snacks but the specially formulated internal coating on the foil makes the end suitable for packing a wide range of food products. The foil end can be printed externally with brand or product information.

Closing – roll on cap

- Aluminum Roll On Pilfer-Proof (ROPP) Spirit Closures



Closing – crown caps



Tin free steel sheet as well as electrolytic tin plate are used to manufacture this cap.

<http://www.alucapsgroup.com>

Closing - continuous thread closures

- Continuous thread closures are commonly known as CTs and they are screwed onto the crown of a glass, plastic or metal container. Inside the caps, a gasket forms a tight seal when pressed against the container's mouth.



Closing – Twist Off Cap

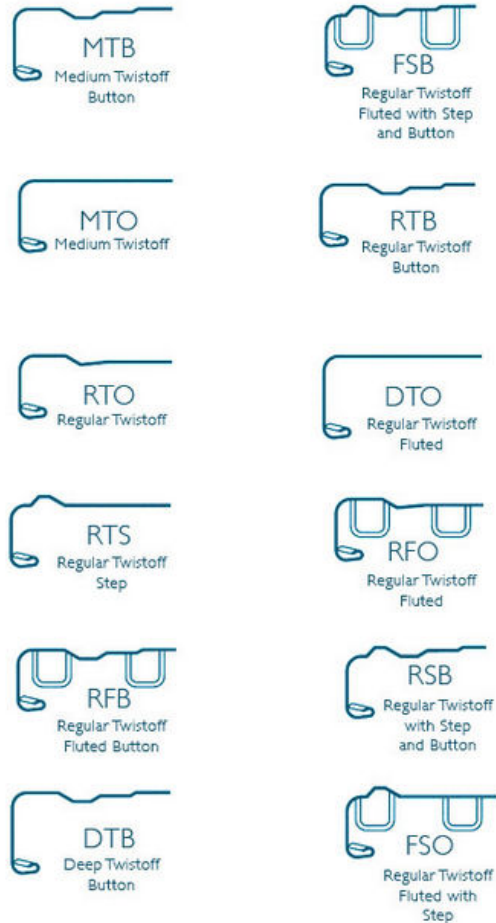

<http://www.alucapsgroup.com>, <http://www.alpack.ie>

Foils

- Tin (not used nowadays)
- Aluminium foils: wrapping of item
- Main application is confectionery products packaging : chocolate bar, pralines, candies, christmass candy, etc.
- Plain and printed version also



Aluminium tray





Textile Packaging of Foods



www.shutterstock.com · 102250330

Plain weave structure

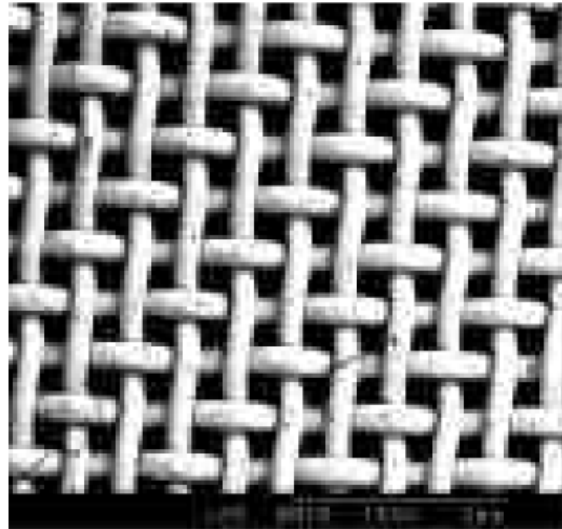

Plain weave

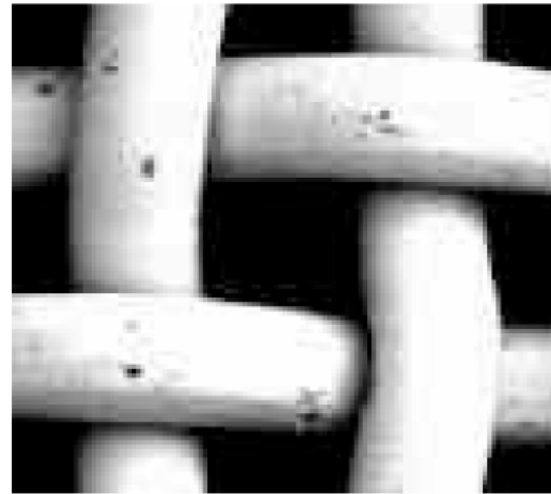

Basic cell

Weave structure

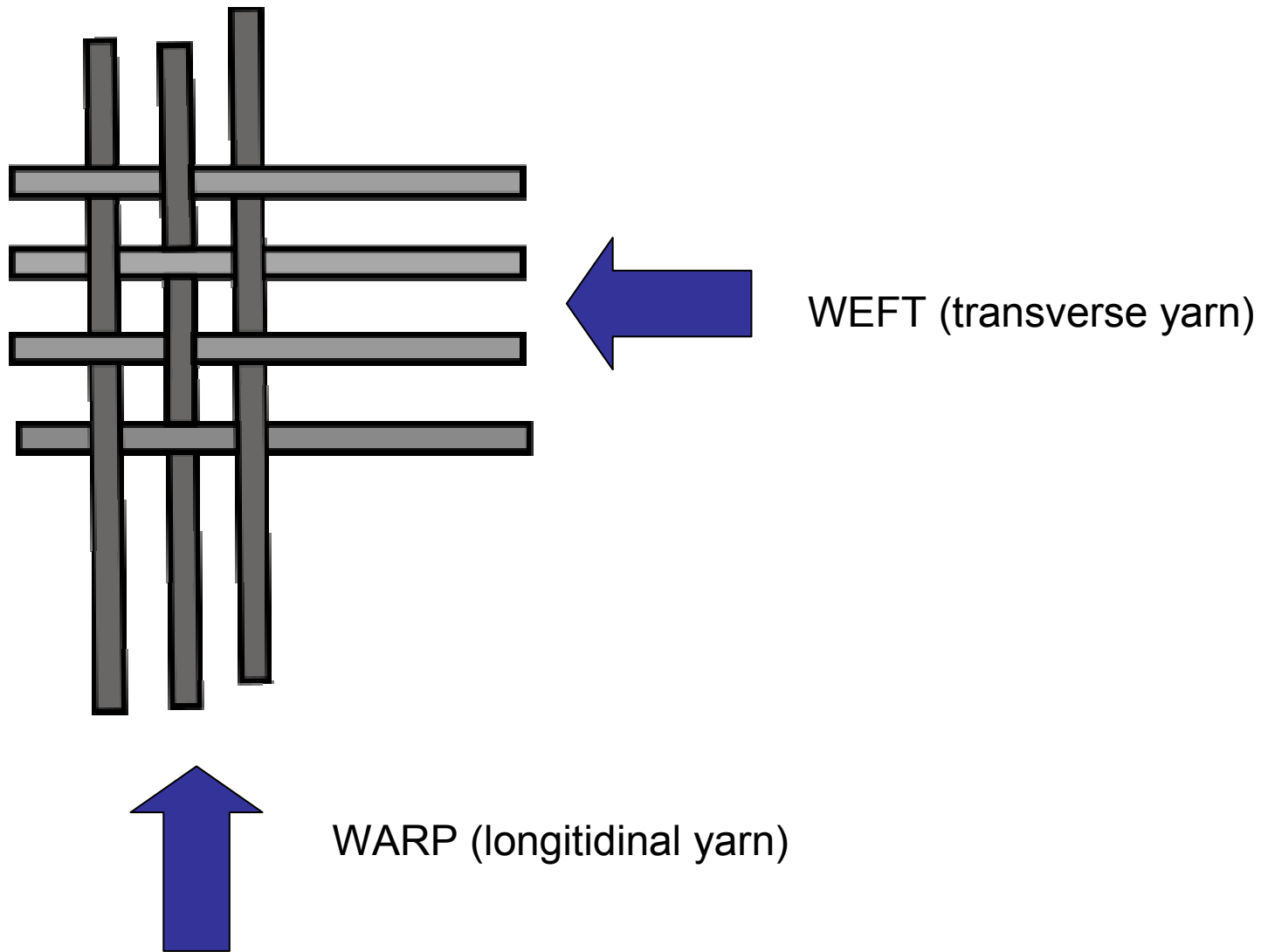

Weave structure

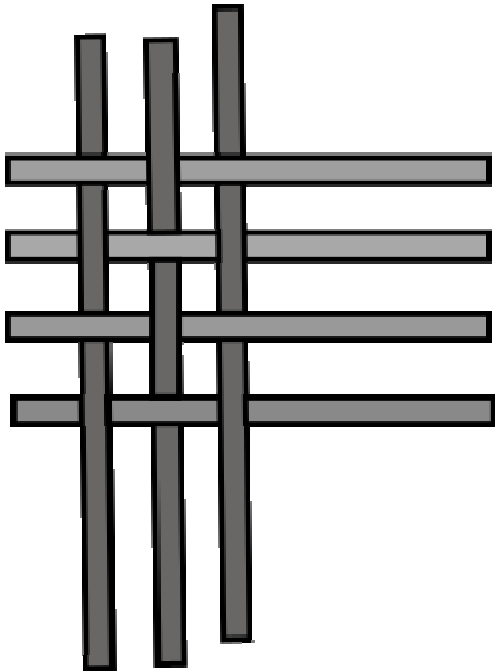

Weaving types

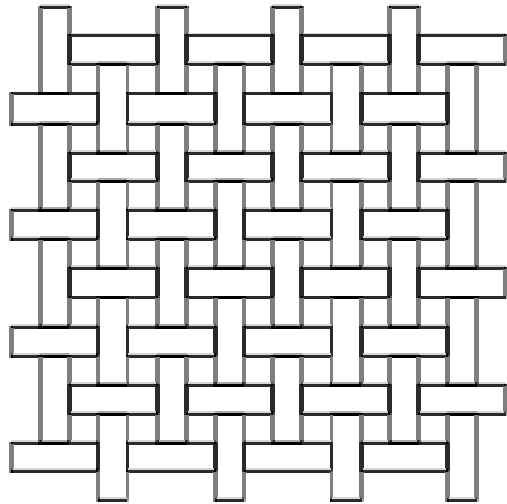

plain weave

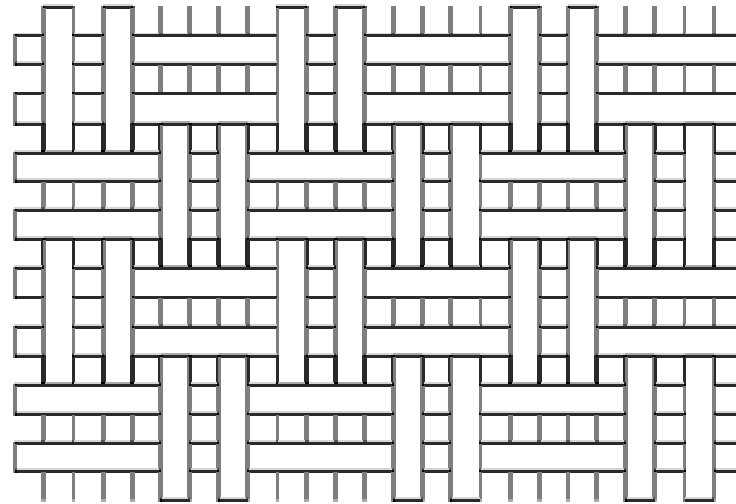

basket weave

Materials of textiles

- Natural source is: hemp, flax,



- Synthetic (artificial) materials: HDPE, PP



Plastic fibre producing

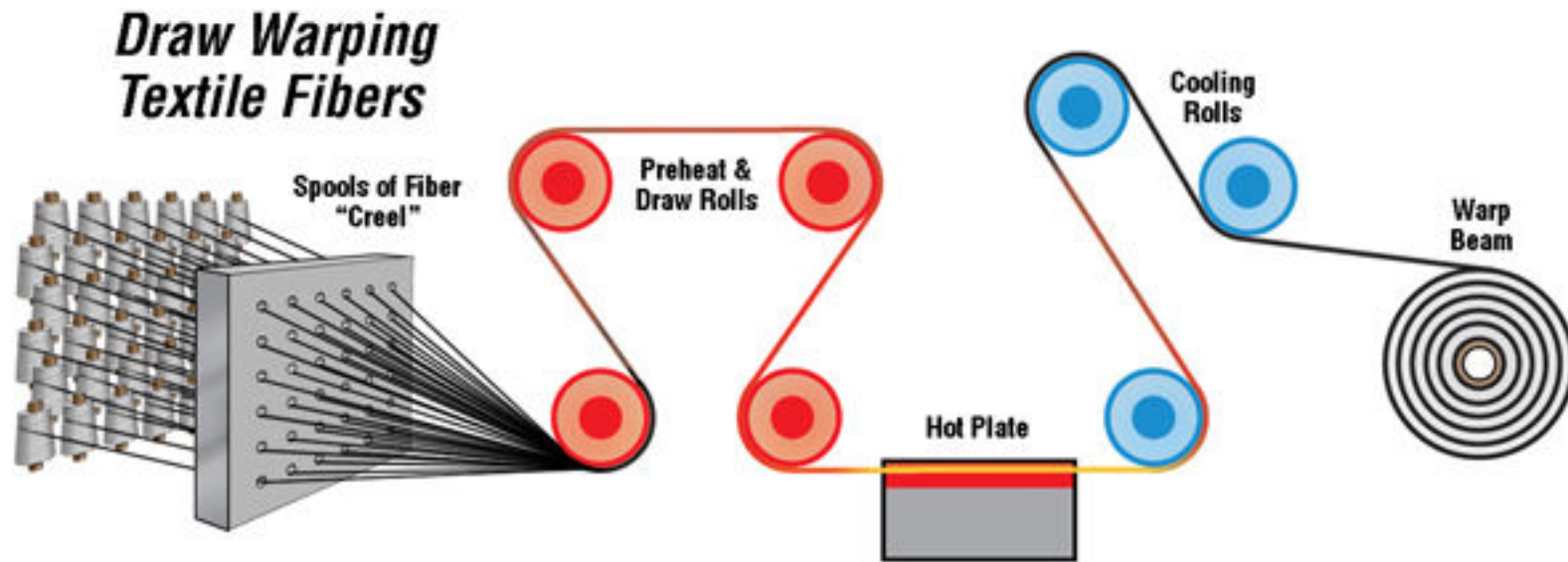

http://www.heat-inc.com/Heating_Industry_Applications/TextileFiber.html

Types of textile packaging

- Polyolefin (HDPE/PP) Woven Sacks
- Flexible Intermediate Bulk Containers (FIBC):
- Leno bags
- Rashel sacks (bags)
- Jute sacks
- Tea-bags (filter paper)

HDPE/PP Woven Sacks

Features of HDPE/PP sacks are:

- Higher Strength
- Light Weight
- Minimal Seepage
- Moisture Proof
- Long Lasting (Durable)



Flexible Intermediate Bulk Containers

FIBC or popularly known as — Big Bag or Jumbo Bag, is similar to the HDPE/PP sacks (bag) but that of a larger size. Capacities ranging from 0.5-4 tons

Features of FIBC are:

- Low cost of material handling from the manufacturer to the end user, inclusive of wastage of material
- Easy filling and discharge
- Savings in loading/unloading time due to ease of handling
- Low weight packing for transport
- Built in safety factor of at least 5:1 on nominal load
- Transportation of empty FIBCs is cheap and space saving
- No requirement of pallets when compared to small bags – self supporting
- Good chemical and organic resistance
- Eco-friendly, since product is recyclable
- Can be used for storage in open air (if UV stabilised)



Leno bags - PP

PP Leno bags are at suitable especially for the packaging of fresh vegetables, fruits, potatoes, onions, etc.

Features of leno bags are:

This bag allows enter the air inside

Suitable for cold storage

Good tensile and burst strength

Low packaging cost and the good way of representation

Rashel bags - HDPE

The HDPE rashel bags/sacks are also suitable for the packaging of fresh vegetables, fruits, potatoes, onions.

Features of rashel bags are:

It allows enter the air inside

Suitable for cold storage

Good tensile and burst strength

Low packaging cost and the good way of representation



Jute sacks

The traditional packaging material is suitable for packaging especially beans (eg. Coffee, cocoa, dry beans, peanut, almond, etc.)

Features of jute sacks are:

- Bags capacity ranges from 25 - 100 Kg
- For the storage of agro -based product , special hydrocarbon free bags are available.
- Heavy duty
- It allows enter the air inside



Tea-bags (filter)

About more than 80% of the tea sold in retail locations in US in bags.

- Tea bag filter paper is made with a blend of wood and vegetable fibers from bleached pulp.
- Most popular fiber is Abaca (Manila) hemp.
- The tea filter is closer the paper packaging than textile
- Nylon mesh tea bags is newer and fast penetrating packaging material.



Non conventional using of jute sacks



HI HONEY,
HOW WAS WORK?

... I FEEL ,
SO USED ...

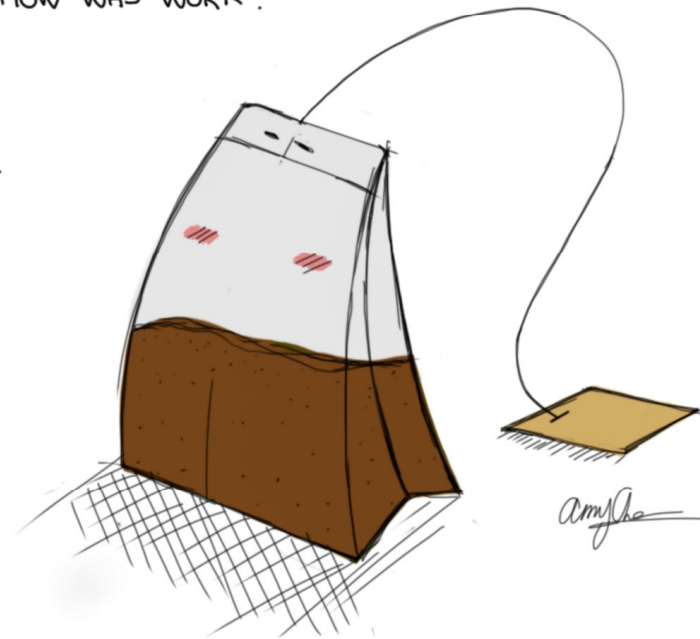
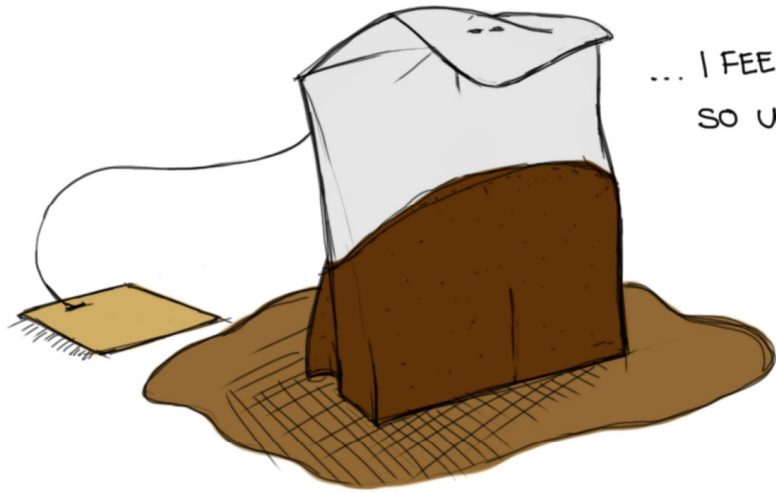

Wood packaging

Crates

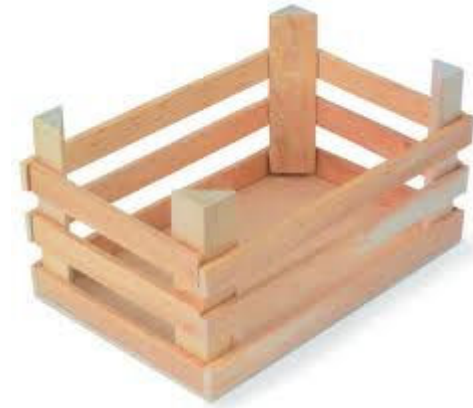

Wood Bins and Containers



Palette – a typical wide use tool

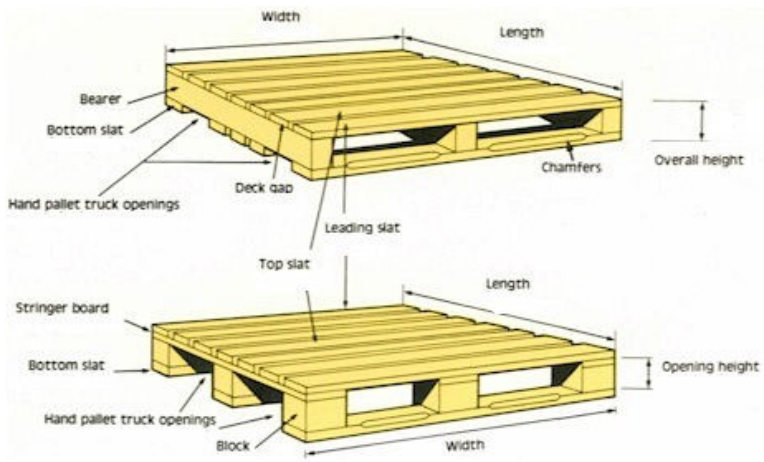

Different form of pallets in packaging and delivery

Two Way Entry
Reversible



Two Way Entry
Close boarded, No Base Board



Two Way Entry
Wing Type



Four Way Entry
Close Boarded, 3 Base



1200 x 800 Euro Pallet



Four Way Entry
Perimeter Base



Four Way Entry
Wing Type



Four Way Entry
Close Boarded, Perimeter Base



Four Way Entry
Open Boarded, 3 Base



Fork Lift Entry

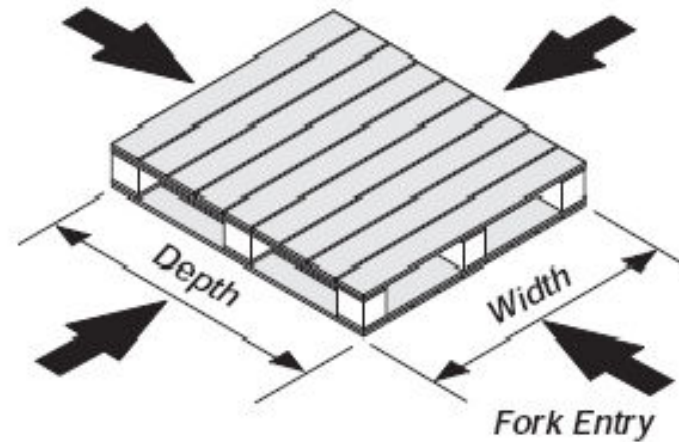
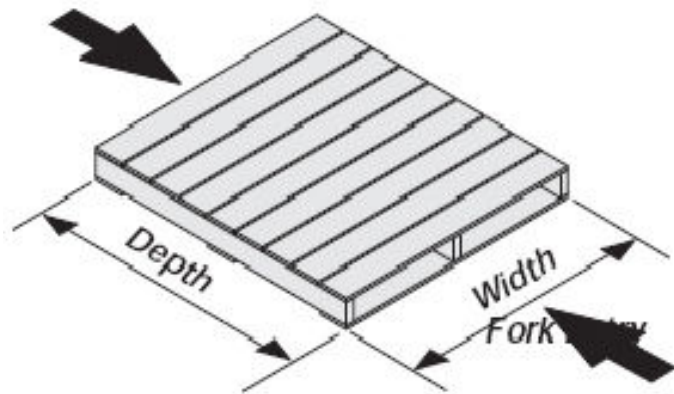
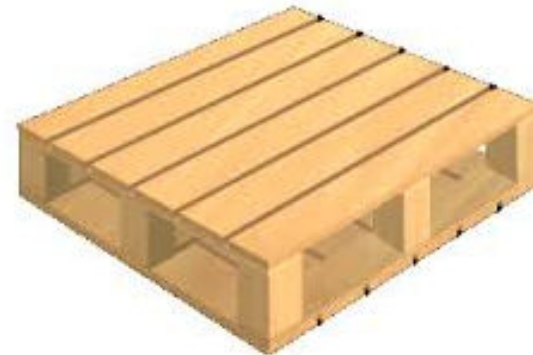

Four way entry pallets

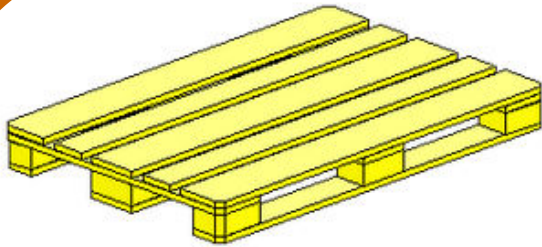

3 Legged Pallet (Similar to a Euro-Pallet)

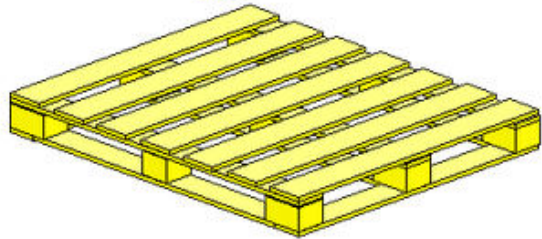

Perimeter Based Pallet

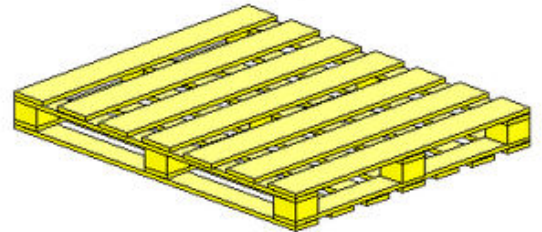

Fully Reversible 4 way entry Pallet

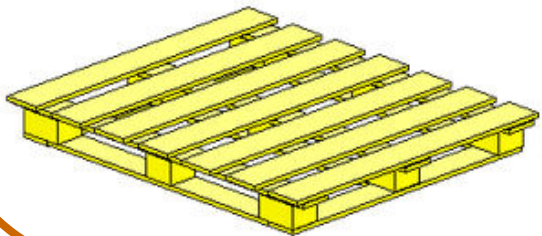

Perimeter Based Winged Pallet

Dimensions of EUR wood pallet

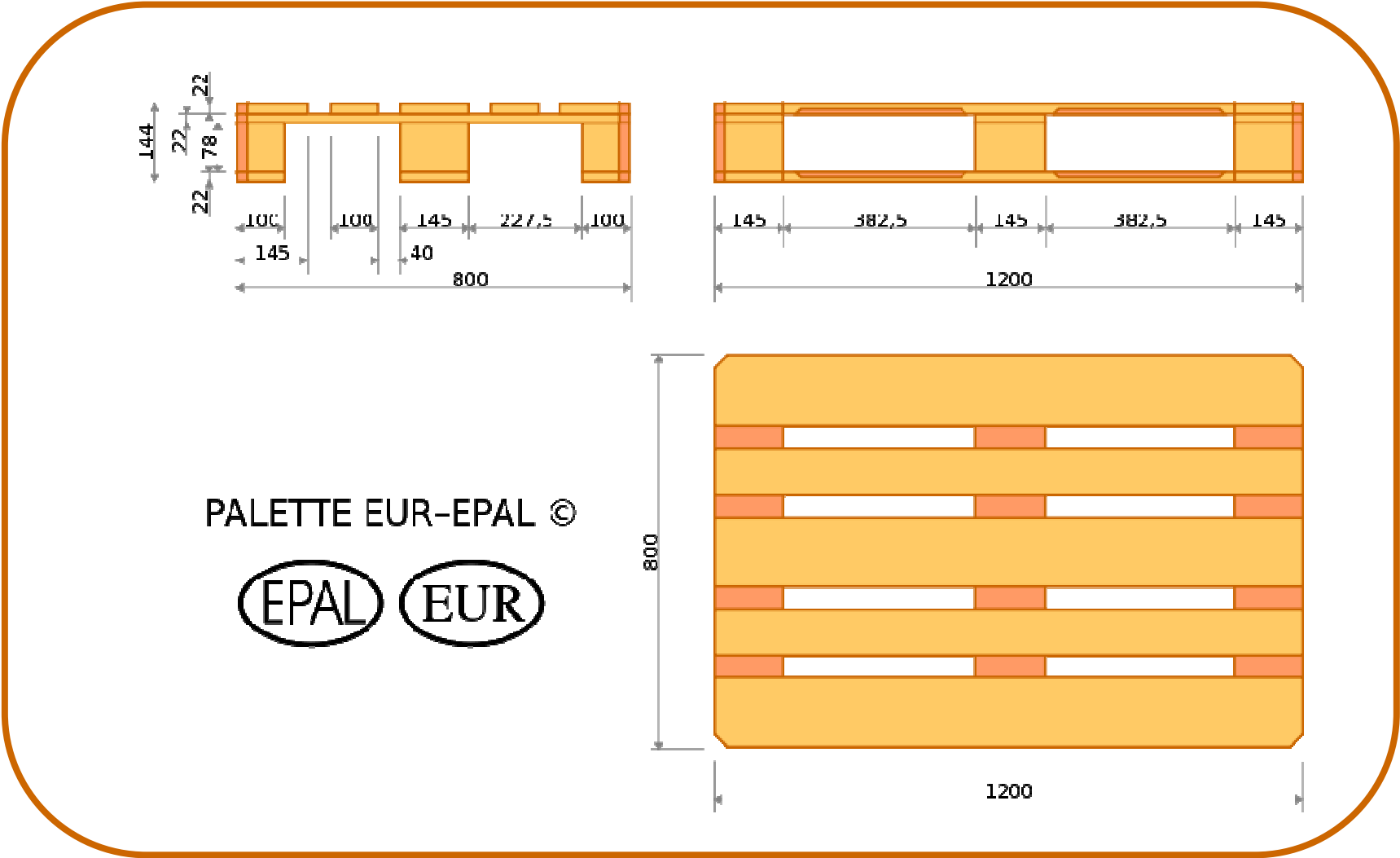

Different kind of EUR palletts



800 x 1200 mm Pallet EUR



1200 x 1000 mm Pallet EUR 2



1000 x 1200 mm Pallet EUR 3

Plastic pallet



Active packaging in nutshell

- **ACTIVE** packaging is intended to sense internal or external environmental change and to respond by changing its own properties or attributes and hence the internal package environment.
- to as interactive or “smart” packaging

Active packaging examples

- OXYGEN SCAVENGERS
- Moisture Control
- GAS-PERMEABILITY CONTROL
- ETHYLENE CONTROL
- ODOR REMOVERS
- AROMA EMISSIONS FROM PLASTICS
- ANTIMICROBIAL PACKAGING
- Carbon Dioxide Absorbers and Emitters/Generators

Oxygen Scavengers

- Antioxidants
- Sulfites
- Boron
- Glycols and Sugar Alcohols
- Unsaturated Fatty Acids and Hydrocarbons
- Palladium Catalysts
- Enzymes
- Yeast
- The Package Material as a Reducing Agent
- Ferrous Iron-Based Scavengers

Material and packaging damages and tests

Testing and investigation types

- Testing of packaging materials such as physical and chemical features of paper, plastic, metal, etc
- Migration test
- Barrier test
- Mechanical and other resistance of packaging such as resistance of vibration,

Chemical analysis

- Contamination Analysis
- Chemical Trace Analysis
- Trace Metals Analysis
- Additives Analyses polymers and plastics
- Toxics in Packaging

Barrier test

Permeability model

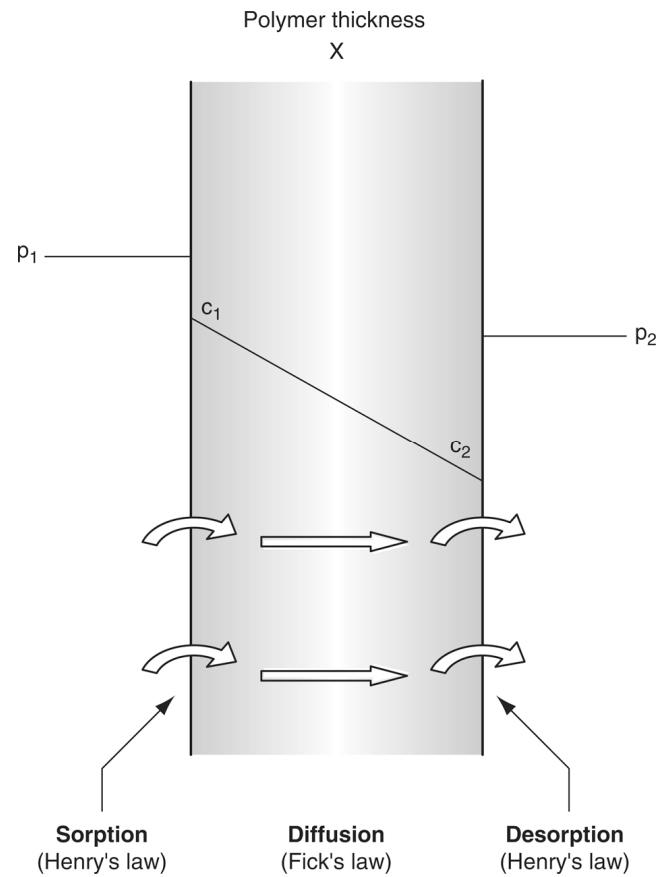

Permeability model for gas or vapour transfer through a polymer. (Source: Robertson (2006): Food Packaging Principles & Practice Routledge/Taylor & Francis Group, LLC.)

Permeability of some plastic materials

Polymer	$P \times 10^{11}$ [mL(STP) cm cm ⁻² s ⁻¹ (cm Hg) ⁻¹]				H ₂ O 90% RH
	O ₂	CO ₂	N ₂		
Low density polyethylene	30–69	130–280	1.9–3.1		800
High density polyethylene	6–11	45	3.3		180
Polypropylene	9–15	92	4.4		680
Polyvinyl chloride film	0.05–1.2	10	0.4		1560
Polystyrene film (oriented)	15–27	105	7.8		12–18,00
Nylon 6 (0% RH)	0.12–0.18	0.4–0.8	0.95		7000
Nylon MXD6	0.01				
Polyethylene terephthalate (amorphous)	0.55–0.75	3.0	0.04–0.06		
(40% crystalline)	0.30	1.6	0.07		1300
Polycarbonate film	15	64			
PVdC copolymer	0.05	0.3	0.009		14
EVOH copolymer					
27 mol% ethylene	0.0018	0.024			
44 mol% ethylene	0.0042	0.012			

© 2006. Adapted from *Food Packaging Principles & Practice* by G.L. Robertson. Reproduced by permission of Routledge/Taylor & Francis Group, LLC.

Representative permeability coefficients of various polymers and permeants at 25°C and 90% relative humidity. (Source: Robertson (2006): *Food Packaging Principles & Practice* Routledge/Taylor & Francis Group, LLC.)

Migration tests - overall

- General (overall) migration
 - Simulants used for global and specific migration testing include:
 - Water (Directive 2002/72)
 - 3 % Acetic Acid
 - 10% en 20% Ethanol
 - Vegetable Oil
 - MPPO (Tenax) - absorption powder
 - Iso-Octane

Migration tests - specific

- Specific migration components analyses include:
 - Terephthalic acid/isophthalic acid
 - Maleic acid/maleic anhydride
 - 1,3-Butadiene
 - Bisphenol A
 - Total primary aromatic amines
 - Phthalates Analysis
 - Isocyanates
 - Epoxidised soybean oil (ESBO)
 - Trace Metals Analysis

Performance tests

- Stability under load
- Stability under when falling down
- Thermal stability
- Tensile strength

Transport vibration of packaging

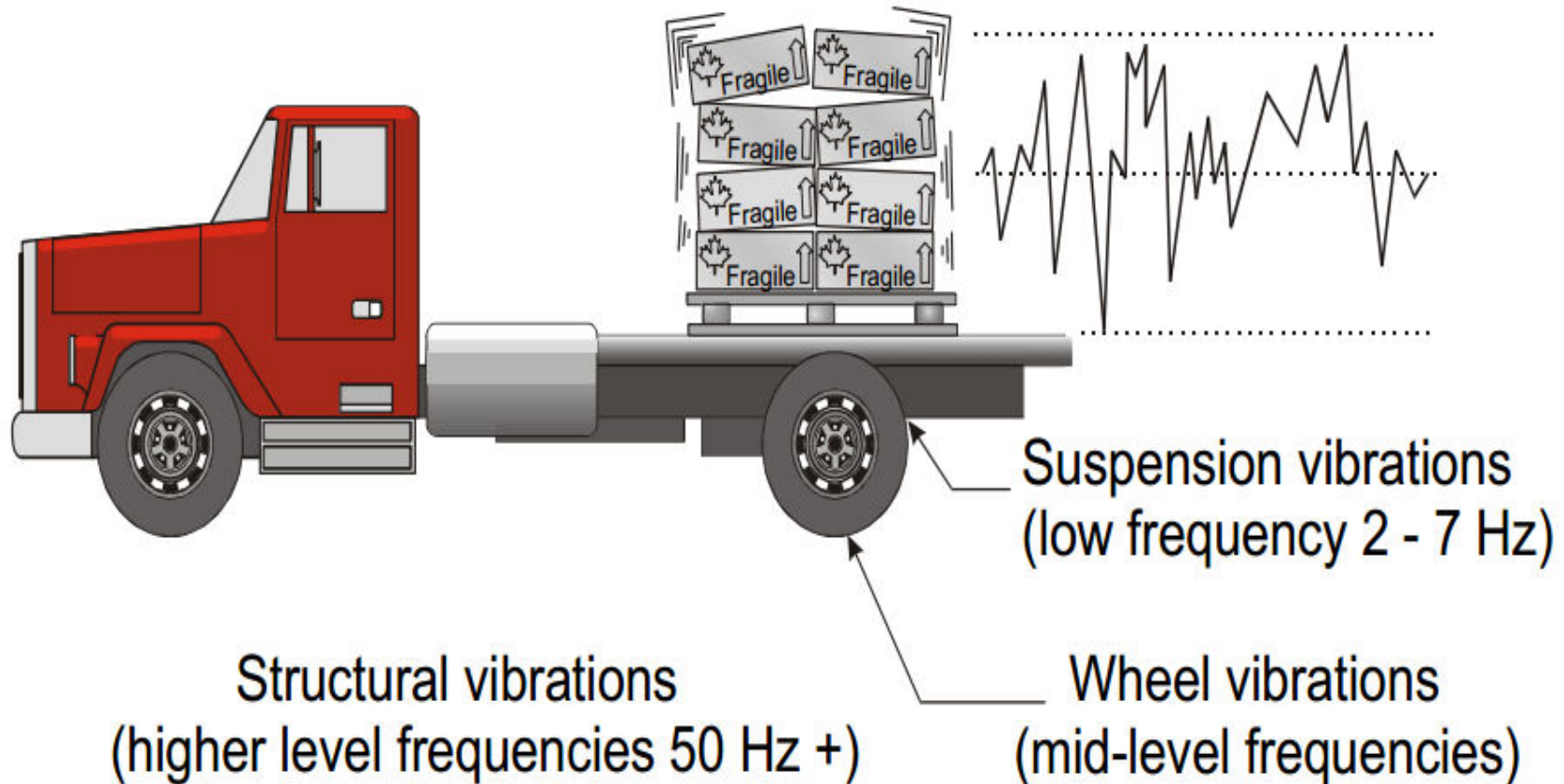

Shock damage

- Greatest damage to shipping containers arises from drops on edges or corners
- Such damage leads to reduced pack performance
- Corner and edge drops tend to transmit less shock to packed product itself



- Most damage to packed products arises from flat drops
- Product damage can occur without visible external evidence of package abuse



Specific tests on plastics packaging

- Tensile test & stretch/elongation test
- Tear test, machine & cross direction (Elmendorf test)
- Moisture vapour transmission test
- Gas permeability tests (oxygen, CO₂, odours)
- Resistance to product, solvents, oils and greases
- Heat and cold (re filling temperatures, etc.); climatic and ageing tests
- Heat sealing strength tests

Specific tests on rigid packaging

- Pressure testing
- Leakage testing
- Closure/seal testing (including closing torque/ease of opening)
- Compression testing
- Drop testing
- Climatic (temperature & humidity)testing/accelerated ageing

Packaging lines

Case studies for food industry

Introduction

Before choosing the best way of packaging to be clarified, that

- chemical properties of food
- physical properties of food
- planned shelf life
- output capacity
- sensitivity
- etc.

Powder packaging - bag

- The bag packaging is a very popular solution for free flow products: wheat flour, sugar, pasta and similar foods.



- Different type and shape is available (brick, stand up pouch, bigger bag, etc.)
- Packaging materials are: paper, laminated paper, laminated plastic, PE, PA, etc.

Bags type for powder

- Pre made bag (ready to fill)
 - block-bottom bags,
 - folded-bottom bags
 - gusset bags
- Flat bag
- 3- and 4-edge sealed bag
- stand-up bag with carrying handle
- stand-up bag with flat-laid top seam
- stand-up bag with glued closure



Powder packaging line pre made bag

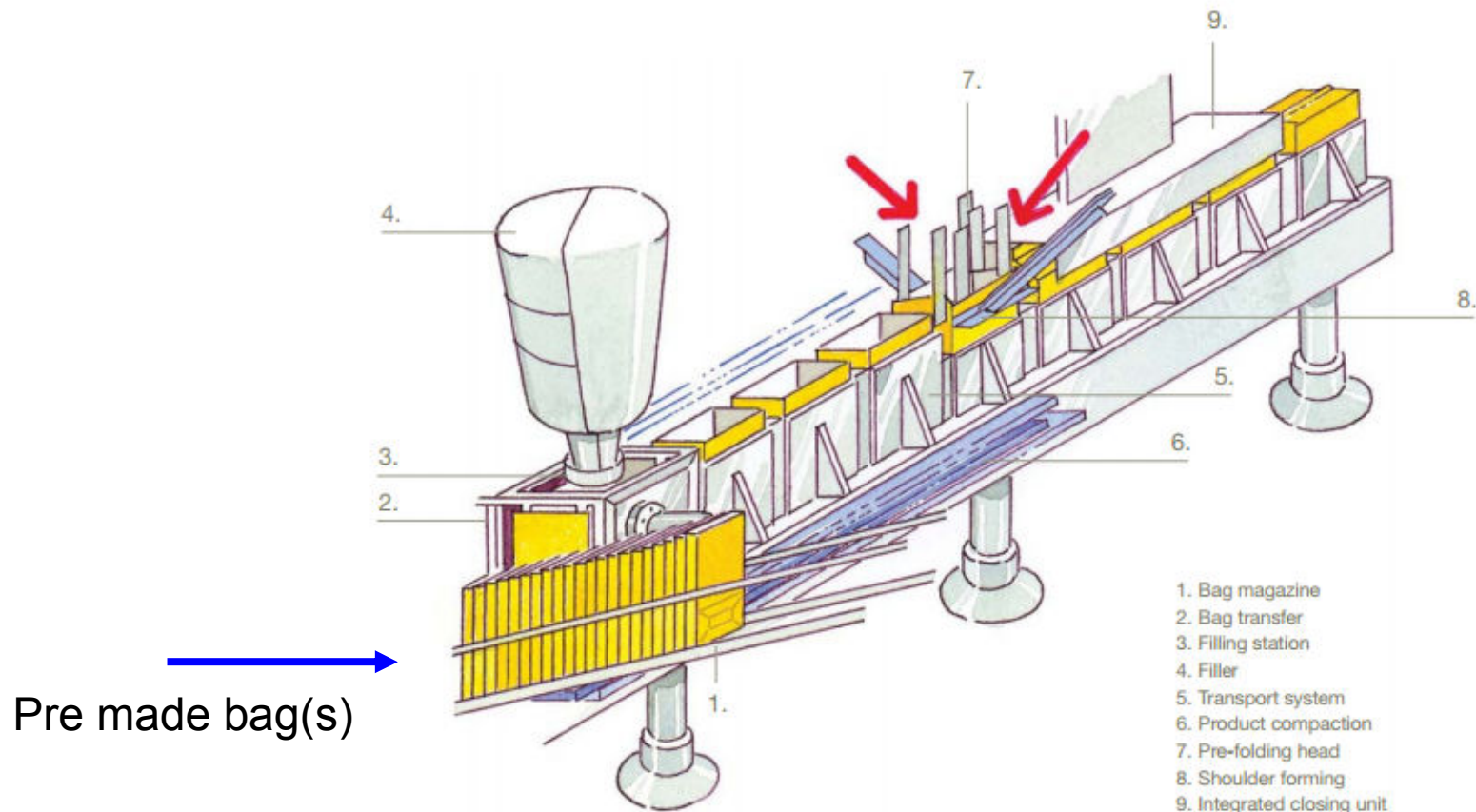

Powder packaging line reel material

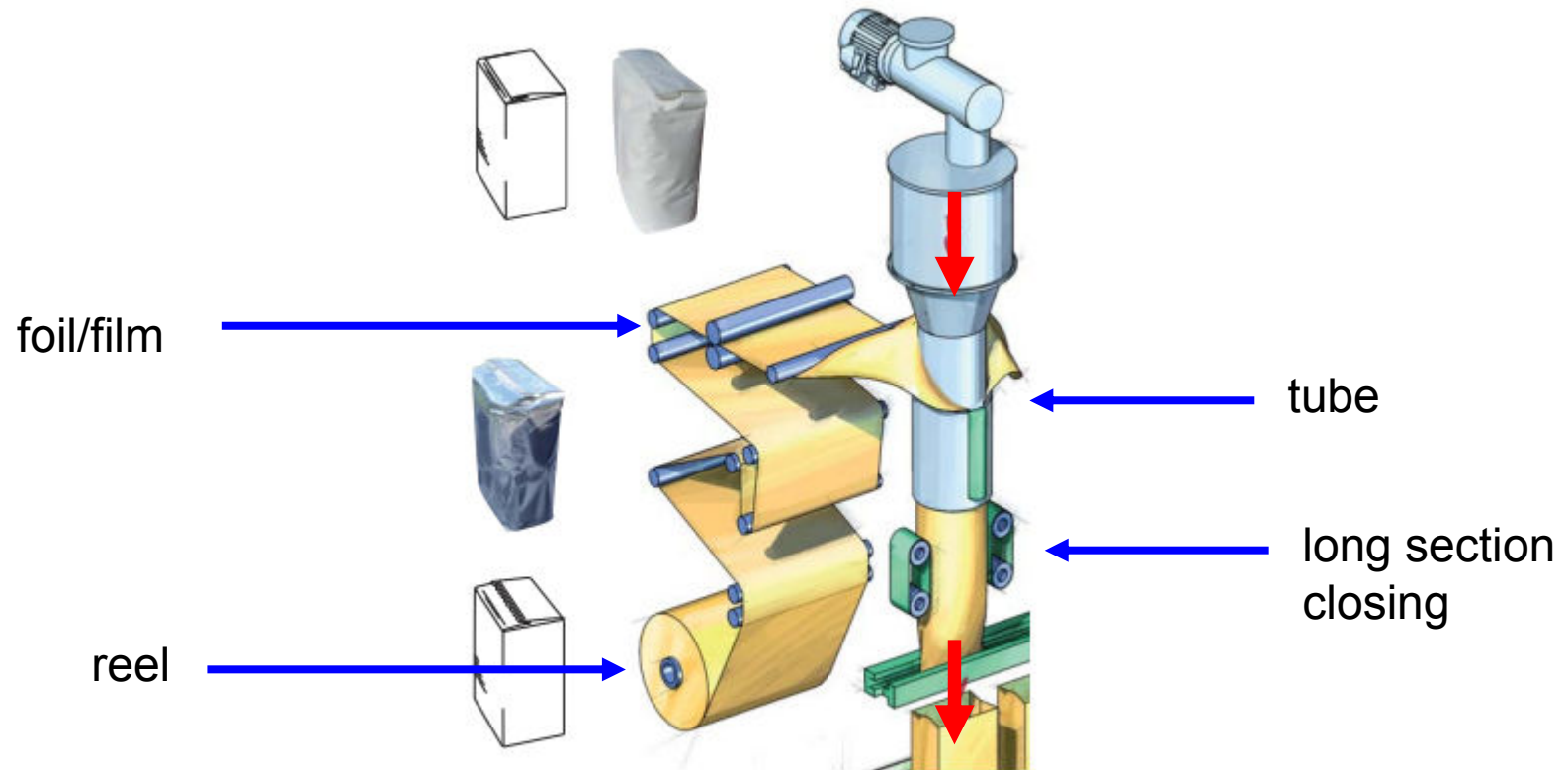

Powder packaging - pouch

- Fast growing solution of food sector mainly in small size foods (coffee, herbs, spices, one portion goods)



- Special form is the stick.
- Usually combined with hang holes. Different type and shape is available (flat, stand up, shaped etc.)
- Packaging materials are: paper, laminated paper, laminated plastic, PE, PA, etc.

Pouch packaging easy to ...

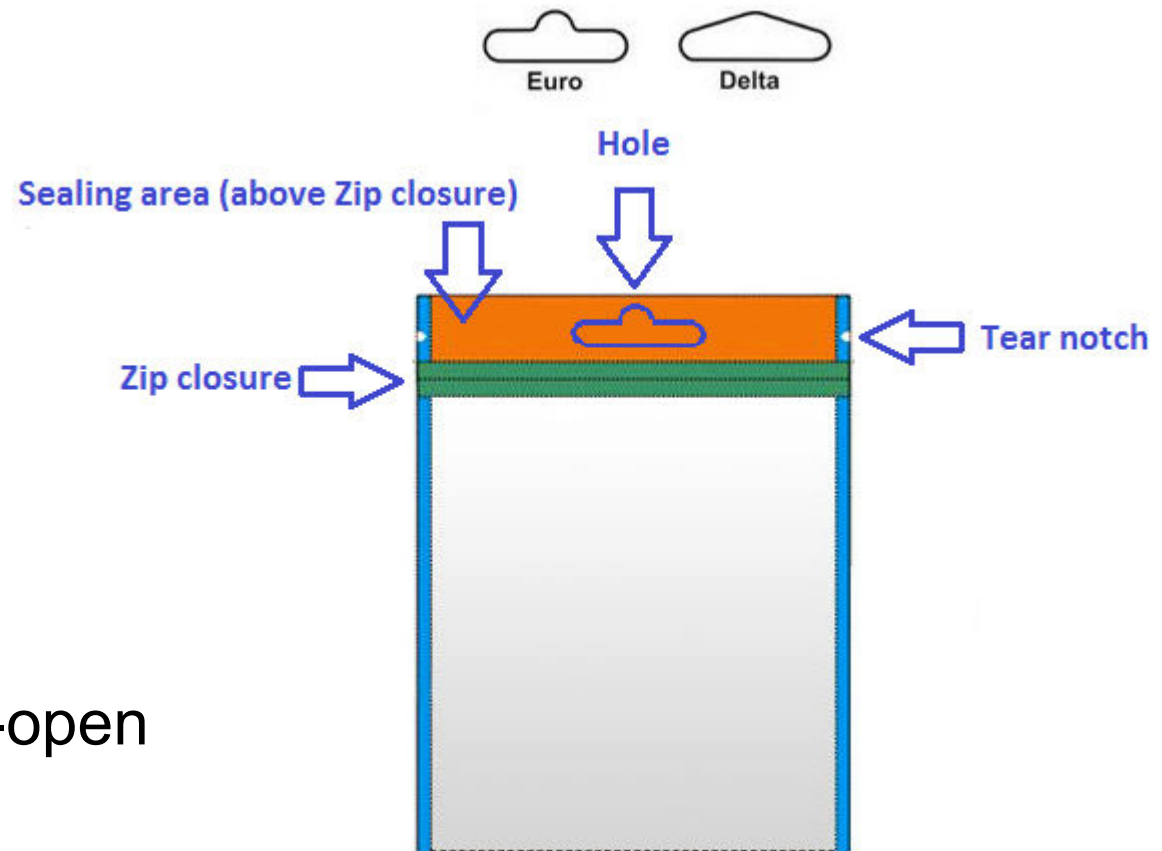

- Hang
- Open
- Re-closed and re-open

Vertical and horizontal FFS

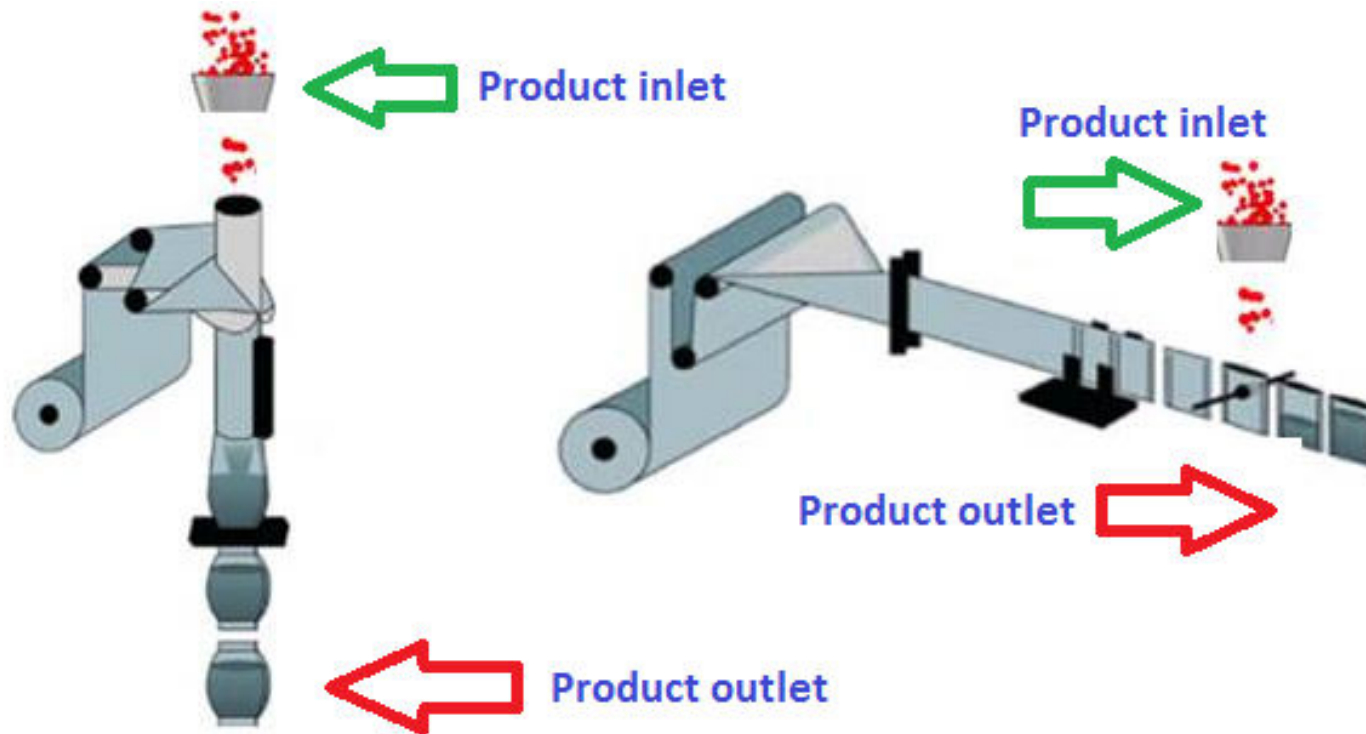

Vertical form-fill-seal

Horizontal form-fill-seal

Aseptic liquid food packaging

- Aseptic packaging is the end phase of aseptic processing.
- Aseptic means : free from septic (microbes)
- The aseptic products are commercial sterility.



Layers of aseptic carton

- The aseptic packages are typically a mix of paper (cca. 70%), polyethylene (LDPE) (cca. 24%), and aluminum (cca. 6%).
- Inside and outside layer is PE

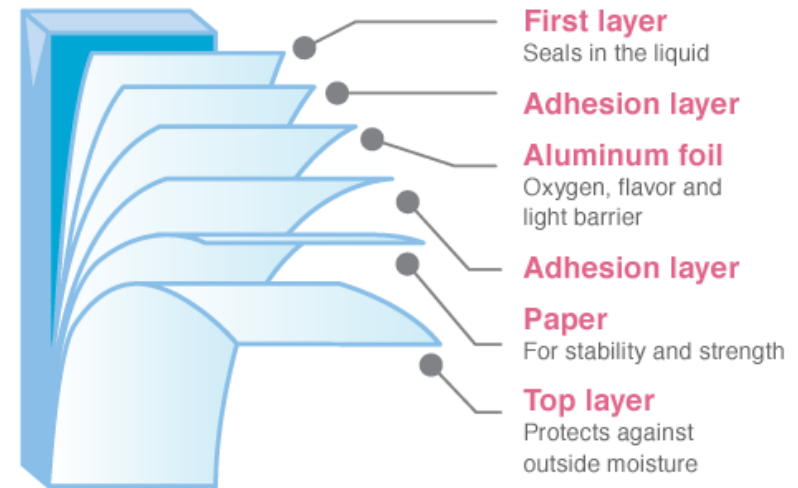

Aseptic systems - cartons

- Two market leaders are Tetralaval and SIG



Why „Tetra”

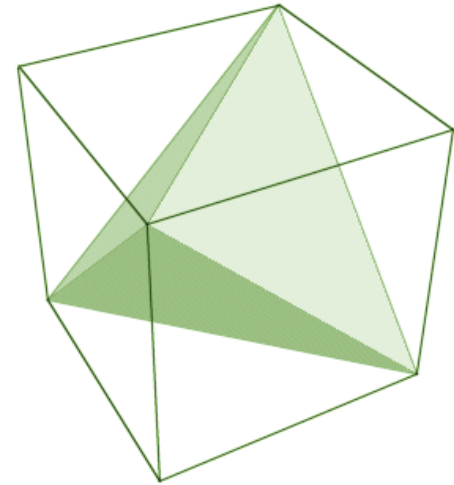
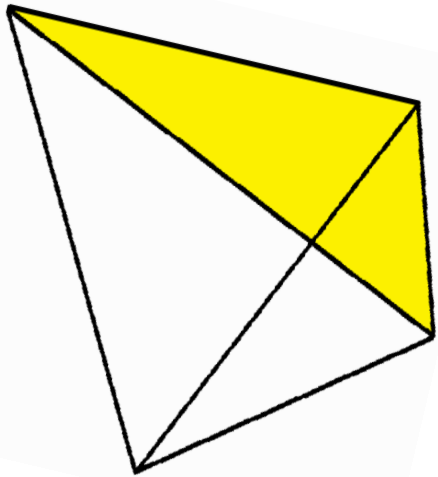

Working principle of Tetrabrik

2: H₂O₂ bath

1: hot air

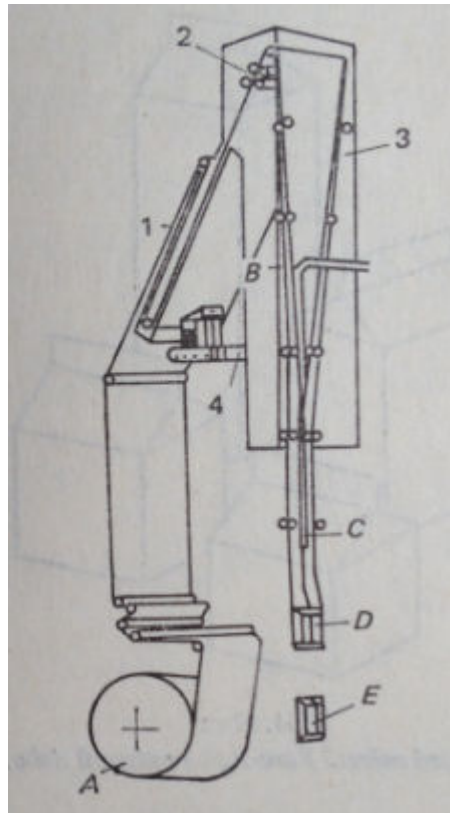

3: sterile chamber

B: container forming

4: air inlet (sterile)

C: filling

D: closing

A: reel

E: product

Candy packaging



1500 pieces/minute



25 candy / sec

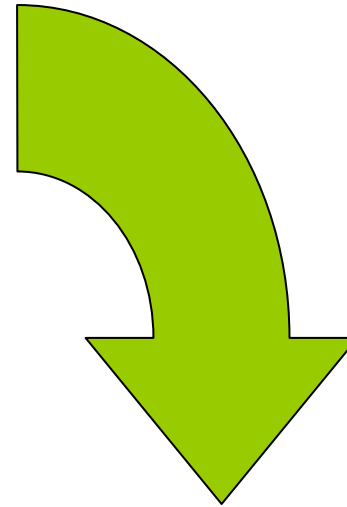

Packaging materials

- Waxed paper
- Cellulose film (cellophane)
- Cast polypropilene (CPP)
- Combined (laminated) film
- Aluminium foil

Cast Polypropylene Film - CPP

- Thickness : 20-200 microns
- Tear resistance: good/excellent
- Optical properties:
 - Gloss
 - Transparency (unstained film)
- Mechanical properties:
 - Stiffness
 - Good tear resistant

Wrapping candy



flowpack



double twist



single twist

Flat or box type wrapping machine

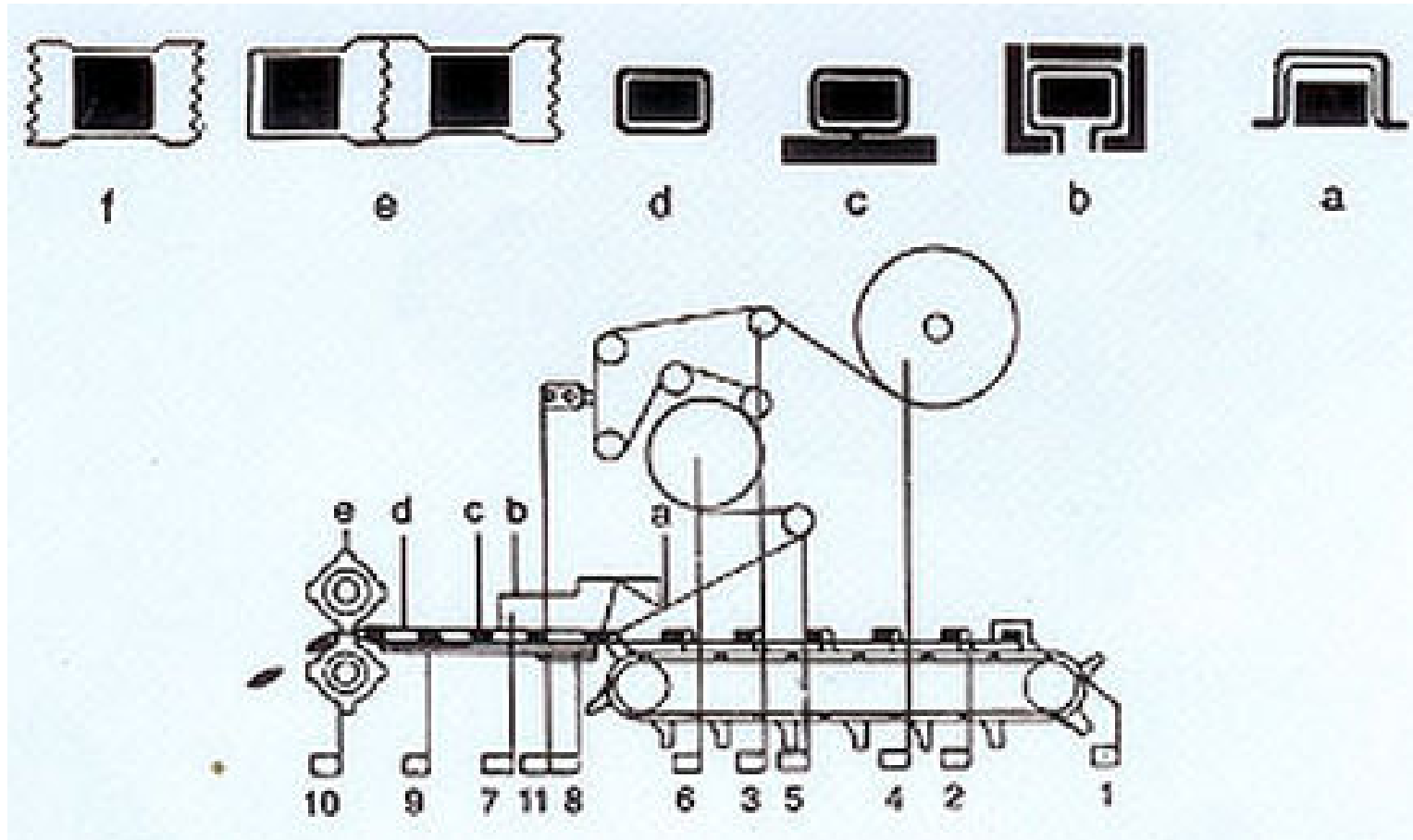

Working principle of double twist wrapped candy

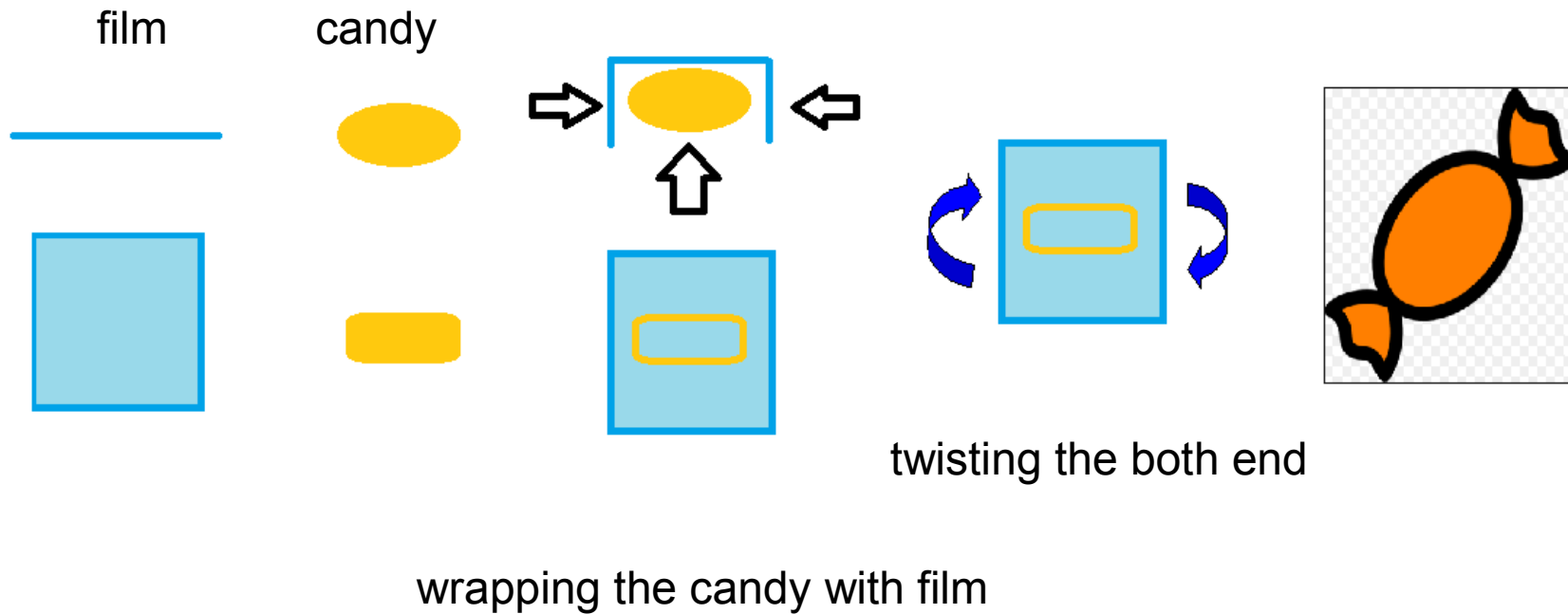

Double twist wrapper WHD type

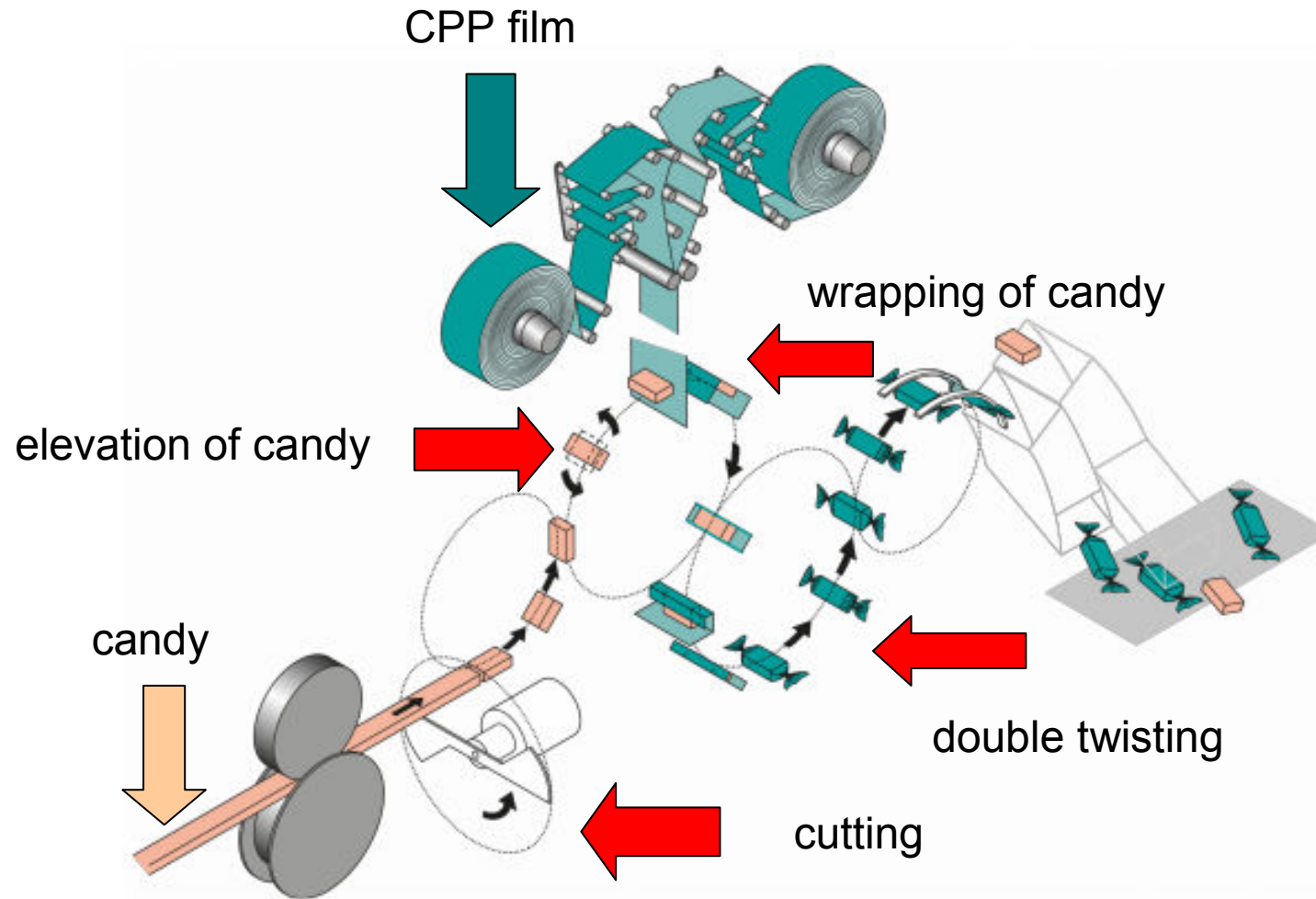

High viscosity liquid foods in pouch

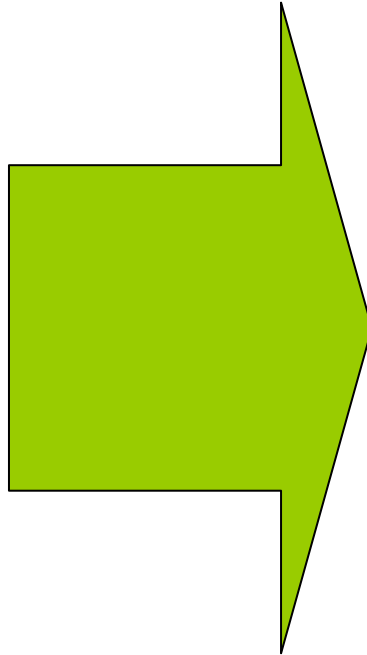

Pouch types for HVLF



spouted pouch

Stand up pouch dimensions

Size		Width	Length	Bottom Gusset
(grams)	(oz)	(mm)	(mm)	(mm)
28	1	80	130	40
70	2	110	160	60
100	3	120	200	60
150	4	130	210	60
250	8	160	230	70
500	16	190	265	90
1000	32	240	335	100
3000	106	300	500	70

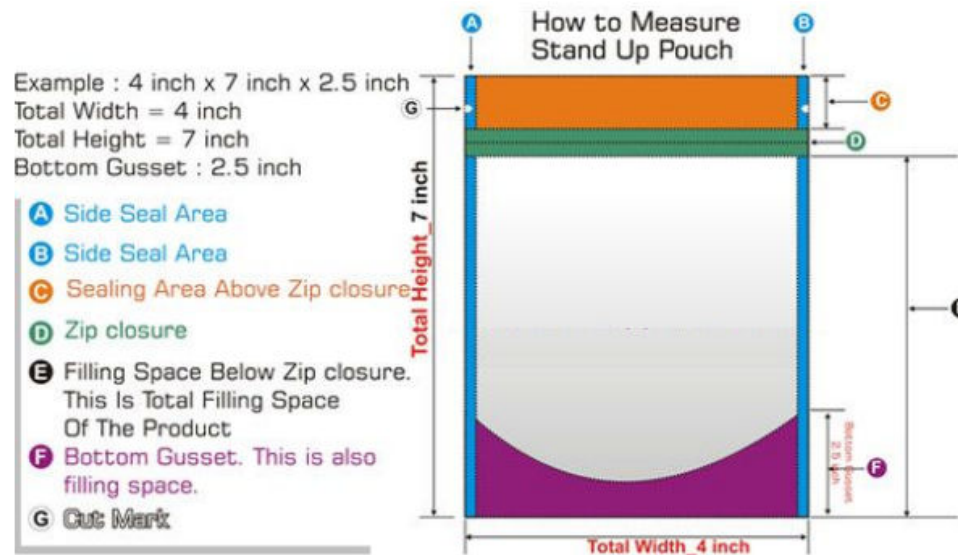

Film layers of pouch

- PET + LLDPE / CPP
- PET + MPET + PE / CPP / RCPP
- PET + VMPET + LLDPE
- PET + aluminium foil + PET/NY + LLDPE
- PET + NY + LLDPE
- PET + aluminium foil + PE
- PET + al. + NYLON + 7 R-CPP (Retort Pouch)
- PET + NYLON + R-CPP (Microwaveable Retort Pouch)
- NY + NY + PE
- NY + PE
- BOPP + CPP
- BOPP + VMCPP

Pouch Filling

- Vertical or horizontal form and fill machine (from film to ready filled pouch)
- Pre made pouch (only filling and closing in site)
- Piston filler is available to fill high viscosity liquids (volumetric filler for low viscosity products)

Filling the pouch

- Filling via spout (and closure with cap)
- Pre made spouted pouch (open side and closing/welding)

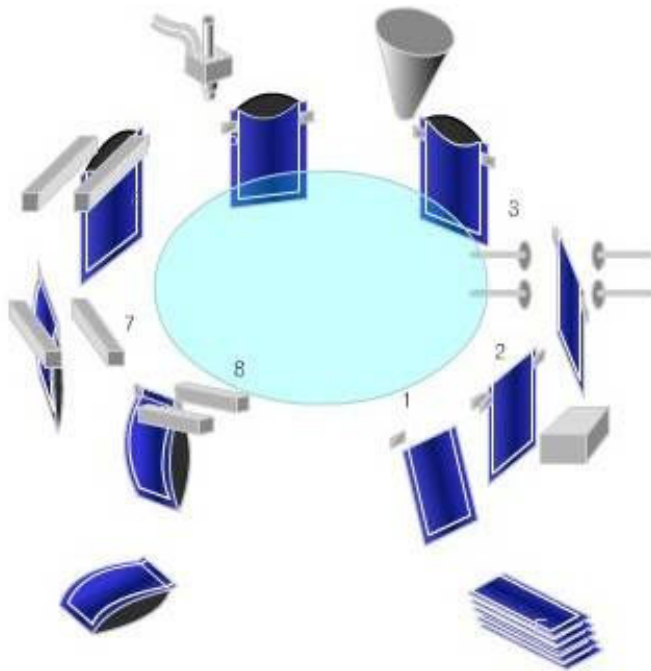

Pre made pouch filling

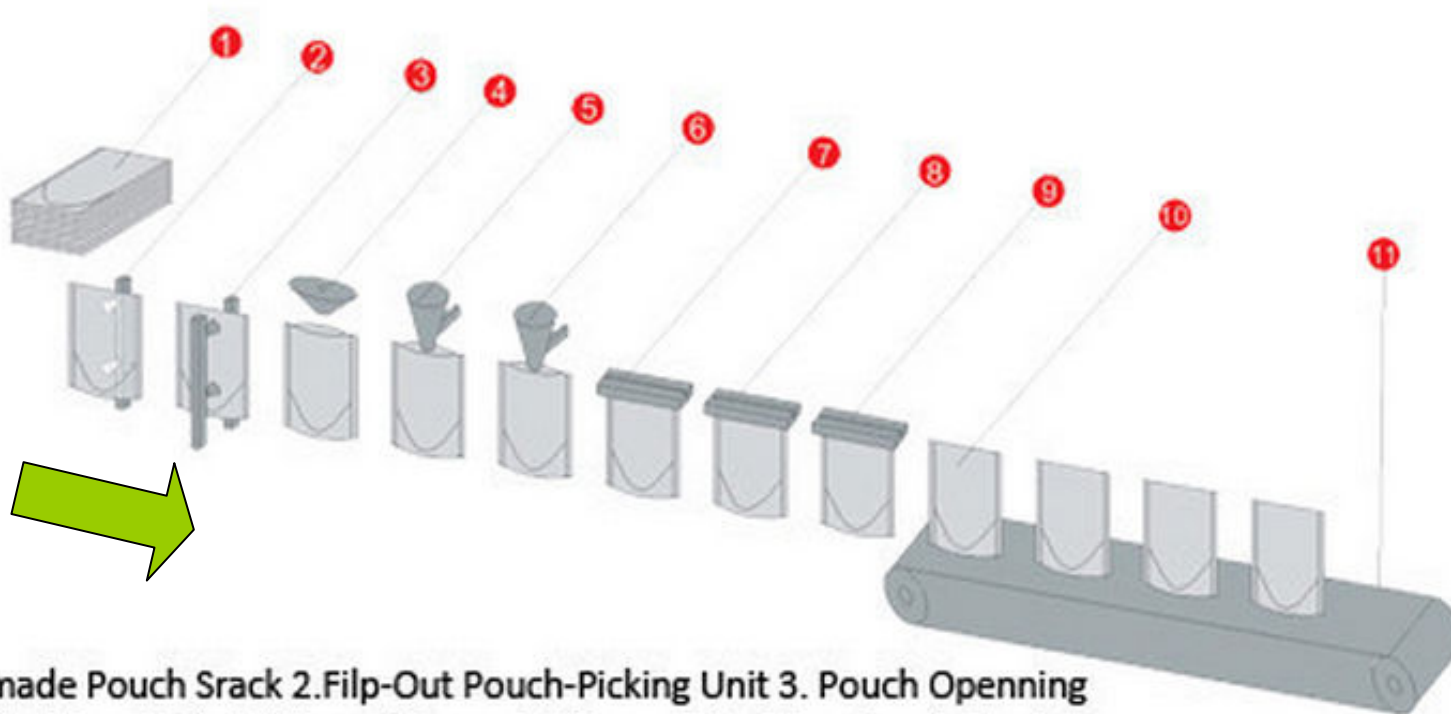

- 1.Pre-made Pouch Rack
- 2.Flip-Out Pouch-Picking Unit
3. Pouch Opening
4. Air Flushing
- 5.First Filling
- 6.Second Filling
- 7.Auxiliary Pouch Stretching
- 8.Heat Top Seal
- 9.Cooling Top Seal
- 10.Finished Product
- 11.Outlet

Vertical form fill seal - stand up pouch

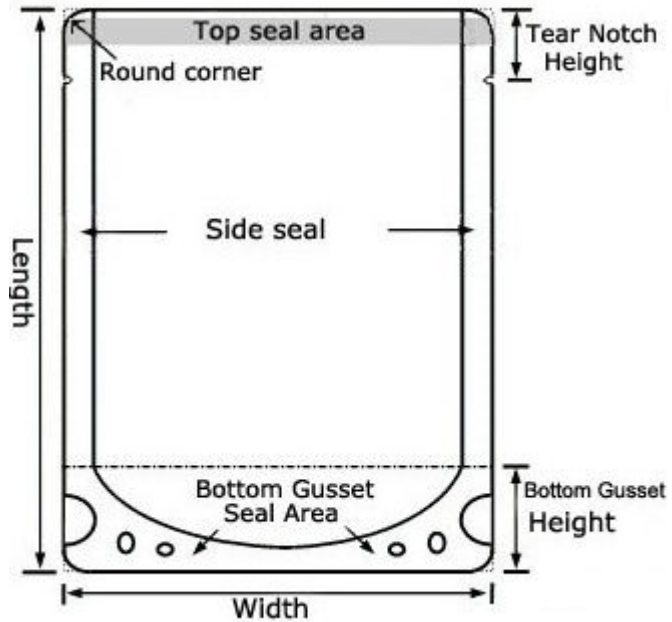

Horizontal form and fill stand up pouch

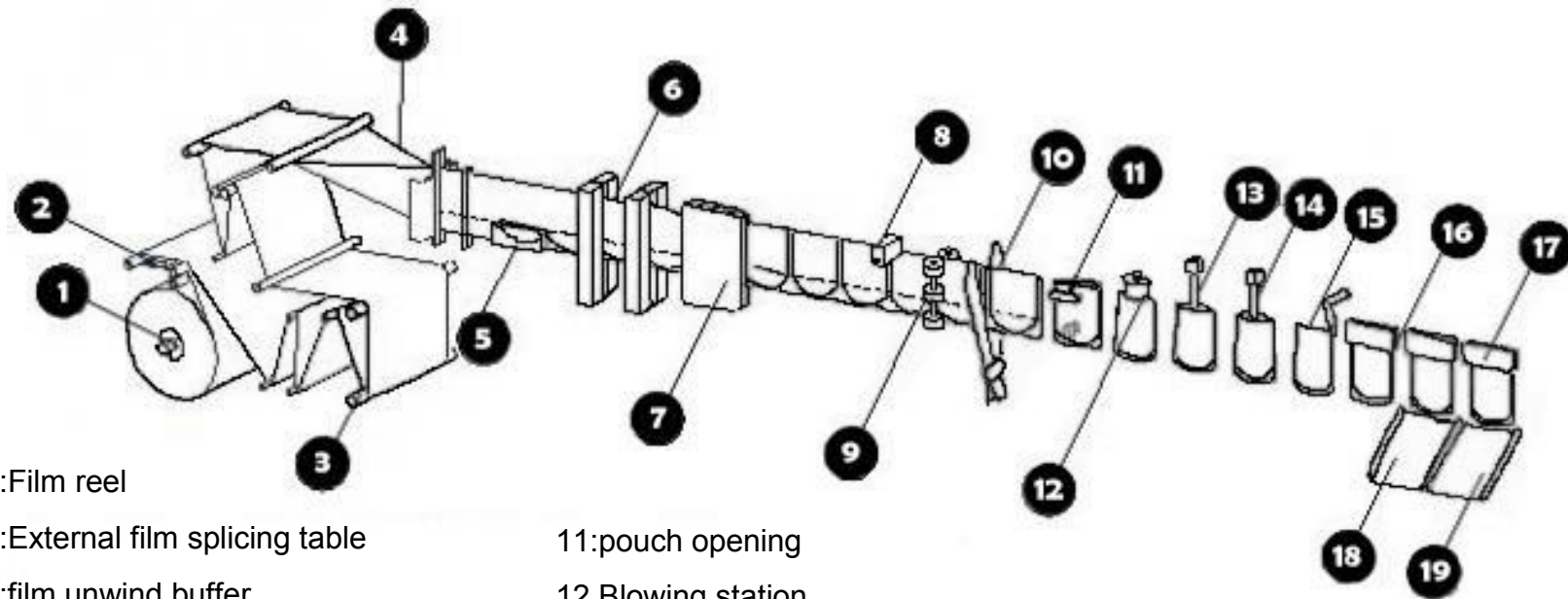

1:Film reel

2:External film splicing table

3:film unwind buffer

4:bottom forming plug

5:bottom seal

6: 1st & 2nd vertical seal

7:seals cooling plate

8:printing center

9:servo film drive

10:pouch cutting

11:pouch opening

12.Blowing station

13: 1 st filling

14: 2 nd filling

15:independent pouch stretching

16: 1st & 2nd top seal

17:top seal cooling plate

18:rejected pouch outfeed

19:pouch discharge

Powder packaging

- Powder and powder like products such as flour, sugar, small seeds, etc. are relatively cheap products therefore the packaging is simple but useful.
- Difference between the higroscopic and non-hygroscopic materials.
- General pupose form is pouch.

Pouch packaging

Main types of pouches



www.mespack.com, www.hpmglobal.com

PILLOW PACK



www.hersonber.com

FLAT POUCH



STAND UP POUCH



STAND UP POUCH WITH ZIPPER



STAND UP POUCH WITH STRAW



STAND UP POUCH WITH EDGE CAP



STAND UP POUCH WITH TOP CAP



STAND UP POUCH WITH FRONT CAP



STAND UP POUCH WITH EDGE CAP AND HANDLE



STAND UP POUCH WITH SPECIAL SHAPE



STAND UP POUCH WITH SPECIAL SHAPE AND TOP CAP



STAND UP POUCH WITH SPECIAL SHAPE AND EDGE CAP



STAND UP POUCH WITH SPECIAL SHAPE AND BOTTOM



STAND UP POUCH WITH SPECIAL SHAPE AND VALVE



FLAT OR STAND UP POUCH WITH DIFFERENT CHAMBERS



VERTICAL FLAT POUCH



FLAT POUCH WITH SPECIAL SHAPE



STICKPACK



VACUUM POUCH

Product	Material composition
Vacuum Pouch	NY/NY/PP, NY/NY/PE, NY/EVOH/PE
High Barrier	Ny/EVOH/PE, PE/EVOH/PE, PE/EVOH/NY/PE



<http://www.hpmglobal.com>

MICROWAVEBLE POUCH

This product is produced to provide convenience to consumers.



The microwavable pouch contains a special polyester film, which has a comparable barrier property to that of the aluminum layer.

RETORT POUCHES



Advantages - efficiencies

Cost efficient: packaging materials and logistics cost

Energy efficient: in container manufacturing, transportation of retort pouches (empty and full) and food processing

Time efficient: about 40% saved in the cook cycle of retort process

Warehouse storage efficient: 85% less space than the equivalent number of empty cans

Shipping efficient: lighter package weight, more food products can be shipped per truckload - in unrefrigerated trucks

Rapid heat penetration and more efficient processing than cans

Improved food quality thanks to

reduced heat exposure: better

<http://www.hpmglobal.com>

<http://www.ampaonline.com/packaging-solutions/type/flexible-packaging/retort-pouches>

SPECIAL POUCHES for MILITARY USE



MRE: Meals Ready to Eat, are self-contained, individual field rations in light weight flexible packaging bought by the military for use in combat or other field conditions where food facilities are not available.

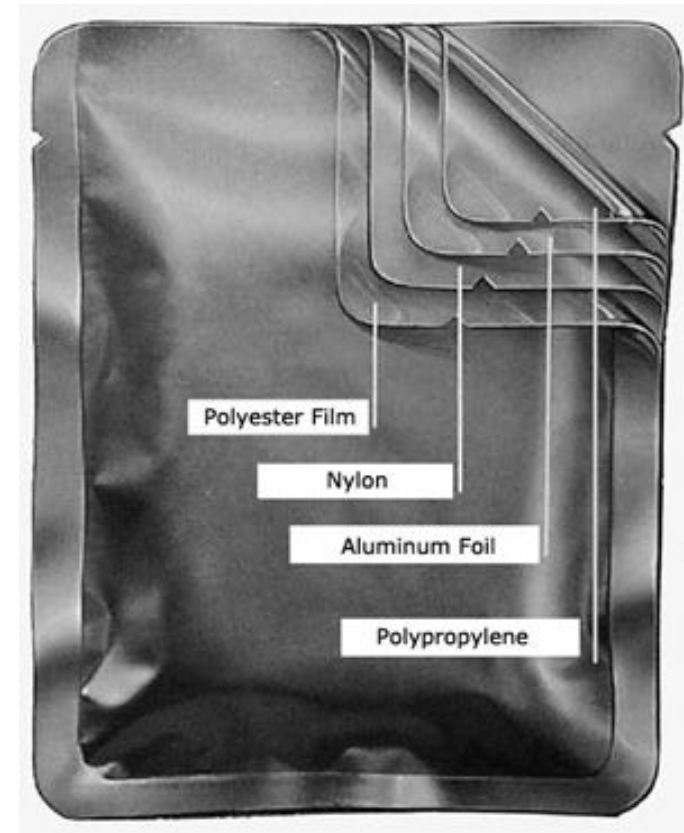

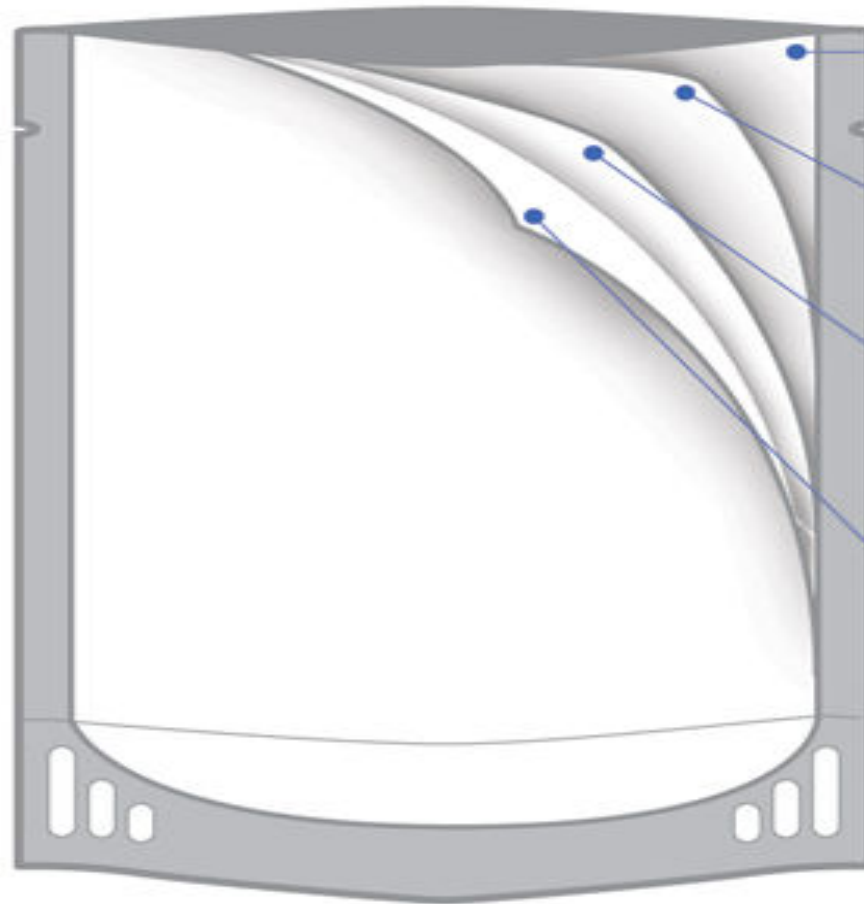

POLYPROPYLENE

Physical Food Contact Layer

- Heat Seal Surface
- Provides Flexibility and Strength

NYLON

- Abrasion Resistance

ALUMINUM FOIL

Barrier Layer

- Protects from Light, Gases, Odors
- Extends Shelf Life

POLYESTER

Outside Layer

- Excellent Printable Surface
- Provides Strength

Case studies...

Packaging & Art

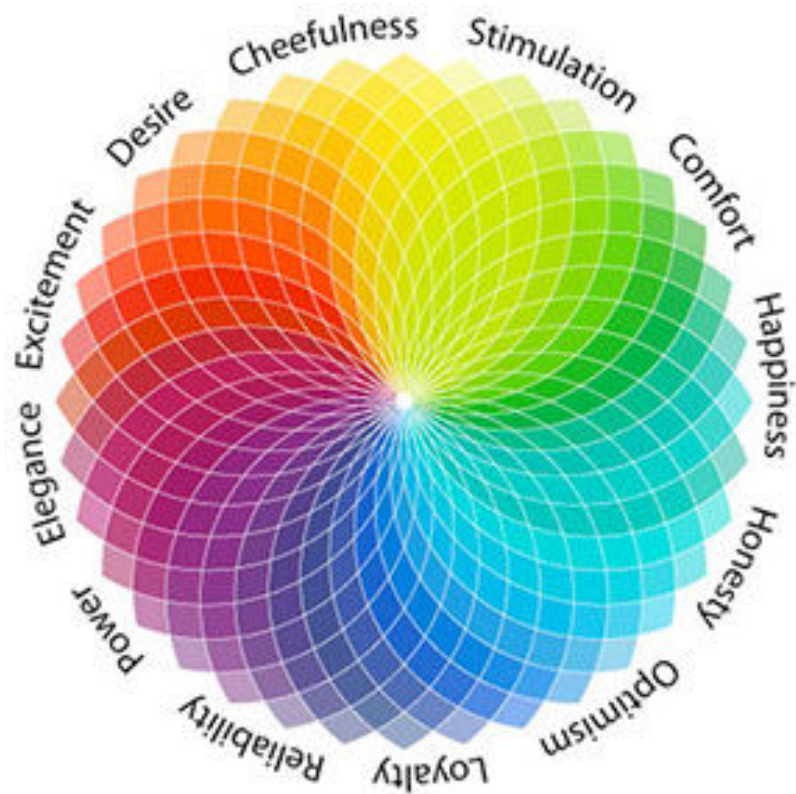

Art ?

- The food packaging is not only strict hard science but it is funny and art, sometimes.
- Is there art behind science and vice versa? YES, of course.

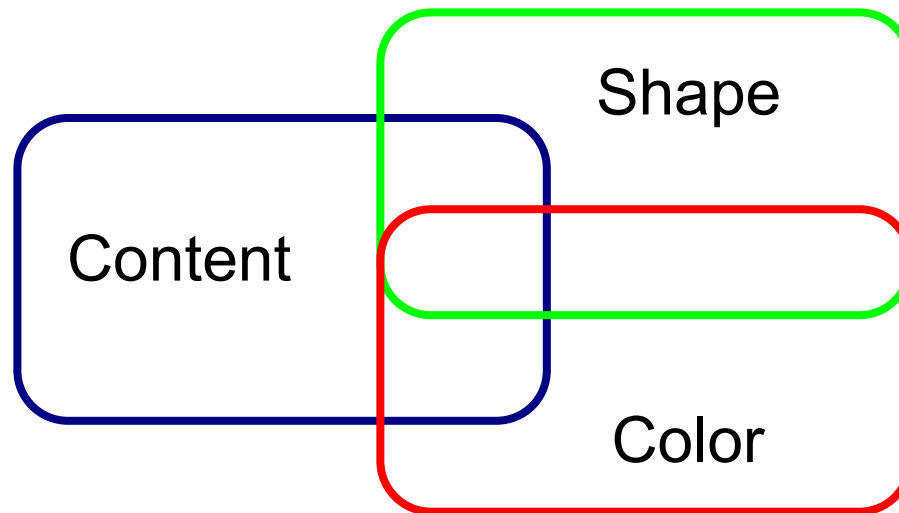

The Psychology of Color

- The color has strong effect to human population.....

Colors - White

- **White** - is the blank canvas waiting to be written upon. It relates to innocence, equality and new beginnings. As a packaging color it is safe, basic, unadventurous and conservative, but a good choice where you want to create the impression of cleanliness, purity, efficiency or simplicity.



Colors - Black

- **Black** – is the color of power, authority and control. Black packaged goods appear heavier and more expensive and transmits a higher perceived value.



Colors - Silver

- **Silver** – packaging foreshadows elegance, sophistication but it is more gentle than gold. This color combines well with almost all other colors.

Colors - Gold

- **Gold** – it means luxury, high price, speciality...

Colors - Red

- **Red** – bright reds, especially on a white background, are a common trademark of “value” brands. Dark reds, however, make people think of luxurious and aspirational products.

Colors - Blue

- **Blue** – blue brings out thoughts of trust, reliability, and strength. Blue is a popular choice for medicines, cleaning products, and business related software. Dark blue is appealing to more mature markets, while lighter or electric shades of blue are appealing to younger consumers

Colors - Yellow

- **Yellow** – is cheerful, optimistic and uplifting to the spirits. It inspires original ideas and creativity. Stimulating to mental abilities, it aids in decision making. In packaging colors yellow suggests either something original and innovative or **a cheap**, fun product. With its positive and happy energy it attracts children and young adolescents.

Colors - Green

- **Green** – is a color of balance and harmony of the mind, the body and the emotions. In color psychology it relates to security, wealth and growth. Green is a good choice for beauty products, health foods, and environmentally friendly goods.

Colors - Brown

- **Brown** – is a color of

Shapes

- The shape of packaged food is similar important as the colour.
- Some foods are hard to distinguish from others.
- And some is not...

- Shapes often determine the first impression of a product while metaphorically communicating key benefits and advantages.



Shape and Color Balance

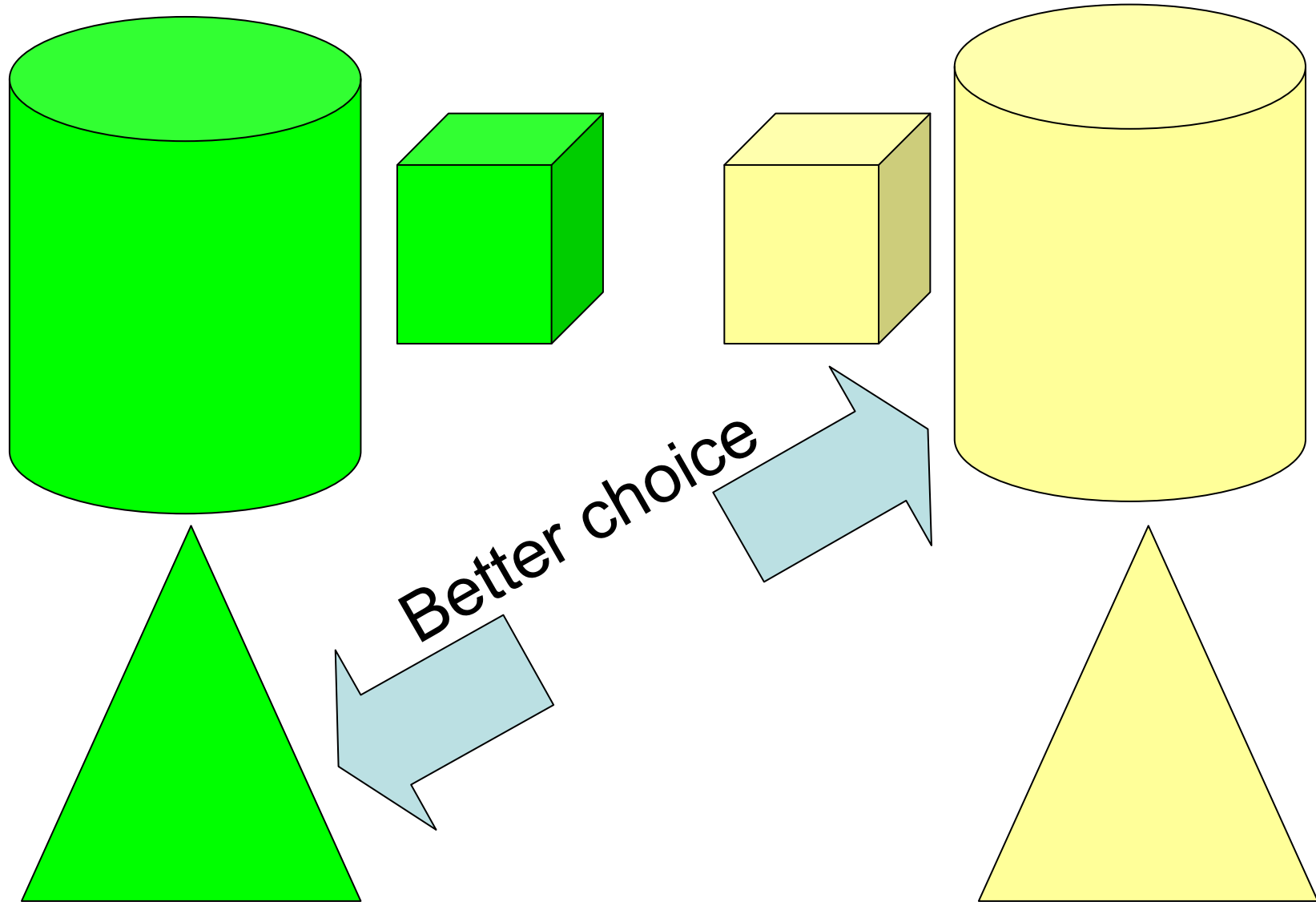

Brain - selection



Visual perception is the primary sense humans have for exploring and making sense of their environment.

Colors trigger a diverse set of responses within the cerebral cortex of the brain and throughout the central nervous system.

Color affects us in deep ways.

The brains are designed to respond to color. This all happens instantly under our conscious awareness.

History of Packaging

Paper:

- One of the most widely used packaging materials.
- Paper may be the oldest packaging.
- The Chinese to wrap foods as early as the First or Second century B.C.

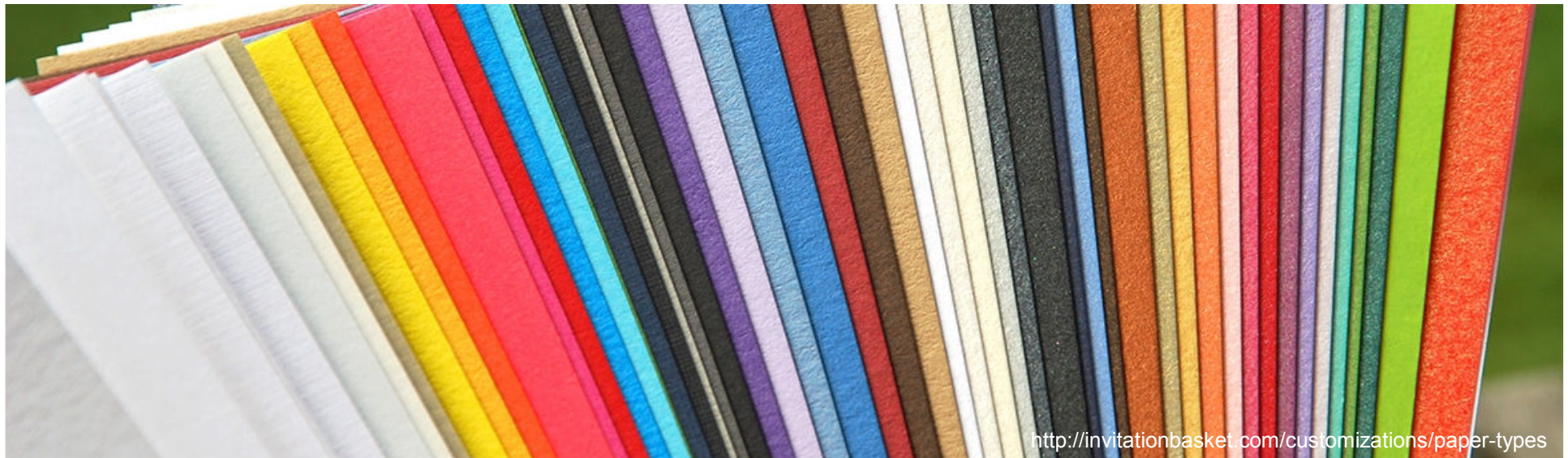

Paper Packaging

- Early paper was made from flax fibers and later old linen rags.
- The paper-making technique was refined and transported to the Middle East.
- Then Europe and finally into the United Kingdom in 1310.
- Eventually, the technique arrived in America in Germantown, Pennsylvania, in 1690.
- 1880's:United States, paper and cartons could be made impermeable to fat and fluid by coating them (with a thin film of paraffin).

Paper Packaging

- It wasn't until 1867 that paper originating from wood pulp was developed.
- The first commercial paper bags were manufactured in Bristol, England, in 1844.
- Francis Wolle invented the bag-making machine in 1852 in the United States.
- Further advancements during the 1870s included glued paper sacks and the gusset design.
- After the turn of the century (1905), the machinery was invented to automatically produce in-line printed paper bags.

Paper Packaging

- The first commercial cardboard box was produced in England in 1817.
- Corrugated paper appeared in the 1850s.
- 1930's: cellophane
- Paper and paperboard packaging increased in popularity well into the 20th century.
- 1952: Tetra Pak in Sweden
- 1980's the development of Modified Atmosphere Packaging (MAP).



History of Packaging

Glass:

- 2500 B.C.= Glass pearls in Babylonia
- 1500 B.C.= Glass vessels in Egypt
- 1000 B.C.= Blowing glass in Syria
- 1600 B.C.= Glass bottles in Sveden





Glass Packaging

- Although glass-making began in 7000 B.C. as an offshoot of pottery.
- It was first industrialized in Egypt in 1500 B.C.
- Glass was pressed into molds to make cups and bowls (1200 B.C.).
- When the blowpipe was invented by the Phoenicians in 300 B.C., it not only speeded production but allowed for round containers.
- Colors were available from the beginning, but clear, transparent glass was not discovered until the start of the Christian Era.

Glass Packaging

- The split mold developed in the 17th and 18th centuries further provided for irregular shapes and raised decorations.
- One development that enhanced the process was the first automatic rotary bottle-making machine, patented in 1889.



History of Packaging

Metals:

- The process of tin plating was discovered in Bohemia in 1200 A.D.
- 14 th: Bavaria
- 19 th: Across Europe (France, United Kingdom) and United States



Metal Packaging

- Cans of iron, coated with tin, were known in Bavaria as early as the 14th century.
- The Duke of Saxony stole the technique, it progressed across Europe to France and the United Kingdom by the early 19th century. (However, the plating process was a closely guarded secret until the 1600s.)

Metal Packaging



- In France, the safe preservation of foods in metal containers was finally realized in the early 1800s.
- Nicholas Appert, a Parisian chef and confectioner, found that food sealed in tin containers and sterilized by boiling could be preserved for long periods.
- A year later (1810), Peter Durand of Britain received a patent for tinfoil after devising the sealed cylindrical can.

Metal Packaging

- In 1868, interior enamels for cans were developed, but double seam closures using a sealing compound were not available until 1888.
- Although commercial foils entered the market in 1910, the first aluminum foil containers were designed in the early 1950s while the aluminum can appeared in 1959.
- Until 1866, a hammer and chisel was the only method. It was then that the keywind metal tear-strip was developed.
- Nine years later (1875), the can opener was invented.



History of Packaging

Plastic:

- Several plastics were discovered in the nineteenth century:
 - styrene in 1831,
 - vinyl chloride in 1835,
 - celluloid in the late 1860s.
- 1950's: Plastics in packagings
 - Polyethylene
 - Polypropylene
 - Polyamide
 - Polystyrene
 - PVC - Poly(vinyl chloride)
 - PETP -Polyethylene terephthalate
 - Polycarbonate
 - Epoxy
 - PUR - polyurethane



Plastic Packaging

- Although discovered in the 19th century, most plastics were reserved for military and wartime use.
- Styrene was first distilled from a balsam tree in 1831.
- Germany refined the process in 1933 and by the 1950s foam was available worldwide.
- Vinyl chloride, discovered in 1835, provided for the further development of rubber chemistry.
- Molded deodorant squeeze bottles were introduced in 1947.
- Heat shrinkable films were developed from blending styrene with synthetic rubber in 1958.

Plastic Packaging

- Cellulose acetate was first derived from wood pulp in 1900 and developed for photographic uses in 1909.
- Although DuPont manufactured cellophane in New York in 1924, it wasn't commercially used for packaging until the late 1950s and early 1960s.
- The Polyethylene Terephthalate (PETE) container only became available during the last 20 years with its use for beverages entering the market in 1977.
- By 1980, foods and other hot-fill products such as jams could also be packaged in PETE.

Why do we need packaging?

- Physical barrier between a product and the external environment.
- Ensuring hygiene and reducing the risk of product wastage due to contamination.
- Prolong the life of food.
- For safe and efficient transportation.
- Used to provide customers with information and instructions, for which there are some legal requirements.

Function of packaging

- Contain products,
- Protects products from contamination,
- Facilitate transportation,
- Carry information,
- Storing of products.

„To contain. To carry. To protect. To preserve”

Containment

- The basic function of packaging.
- Without containment, pollution could become widespread.
- The containment function of packaging makes a huge contribution to protecting the environment from the myriad of products (which are moved from one place to another place).

Protection

- The primary function.
- Protect their contents from outside environmental effects:
 - water,
 - moisture vapour,
 - gases,
 - odours,
 - microorganisms,
 - dust,
 - shocks,
 - vibrations,
 - compressive forces, etc.

Protection

- Chemical protection:
 - Gases (typically oxygen),
 - Moisture (gain or loss),
 - Light (visible, infrared, or ultraviolet).
- Biological protection:
 - Microorganisms (pathogens and spoiling agents),
 - Insects,
 - Rodents,
 - Other animals.

Protection

- Physical protection:
 - Mechanical damage,
 - Includes cushioning against the shock,
 - Vibration encountered during the distribution,
 - Abrasions, and crushing damage.



Convenience

Convenience features:

- ease of access,
 - handling,
 - disposal,
 - product visibility,
 - resealability,
 - microwavability.
- Household products (pre-prepared, can be cooked or reheated in a very short time).
 - Package design ("consumer" size).
 - Package shape.



Convenience

Two other aspects of convenience are important in package design:

- One of these can best be described as the apportionment function of packaging.
- In this context, the package functions by reducing the output from industrial production to a manageable, desirable "consumer" size.

Communication

"a package must protect what it sells and sell what it protects"

- A package is the face of a product.
- The package may be designed to enhance the product image and/or to differentiate the product from the competition.



KENENG PRINT



Communication

- The package on the shelf is the main link between the producer and the purchaser.
- The package is the promise to the consumer of what is inside that package.
- Thus, recognizable packaging is extremely important, if not essential.
- Graphic designs that hide, obscure, or otherwise deceive are self-defeating because consumer frustration is perhaps best expressed by rejection during the purchase-decision process.

Communication

Information to the consumer:

- product identification,
- nutritional value,
- ingredient declaration,
- net weight,
- manufacturer information,
- cooking instructions,
- brand identification,
- pricing.



Environmental



Source reduction - waste prevention:

- is reducing the amount and/or toxicity of the waste ultimately generated by changing:
 - the design,
 - manufacture,
 - purchase,
 - or use of the original materials and products.
- encompasses using less packaging, designing products to last longer, and reusing products and materials.

Package environments

The packaging has to perform its functions in three different environments:

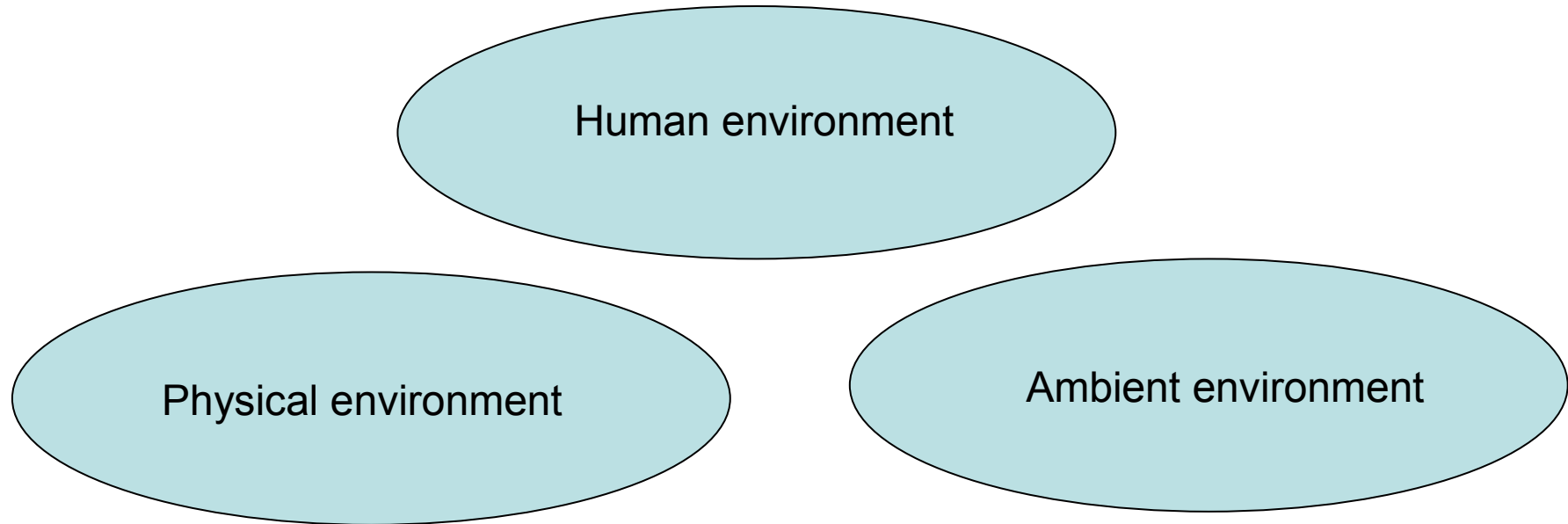

Physical environment

It includes:

- Shocks from drops, falls and bumps.
- Damage from vibrations arising from transportation modes (including road, rail, sea and air) and compression and crushing damage arising from stacking during transportation or storage in warehouses, retail outlets and the home environment.

Ambient environment

- Damage to the product can be caused:
 - as a result of gases (particularly O₂),
 - water and water vapour,
 - light (particularly UV radiation),
 - temperature,
 - micro-organisms (bacteria, fungi, molds, yeasts and viruses),
 - macro organisms (rodents, insects, mites and birds).
- Contaminants in the ambient environment such as exhaust fumes from automobiles (dust and dirt).

Human environment

- This is the environment in which the package interacts with people and designing packages for this environment requires knowledge of the variability of consumers capabilities including:
 - vision,
 - strength,
 - weakness,
 - dexterity,
 - memory,
 - cognitive behaviour.
- The package should contain a portion size which is convenient for the intended consumers.
- A package which contains so much product that it deteriorates before being completely consumed clearly contains too large a portion.

Environmental - reduce

- Using less packaging and by meeting all or most of the 3R's hierarchy, including reuse and recycle.
- Minimizing the number of materials used.
- Minimizing the weight and volume of materials used.
- Employing bulk delivery systems.
- Product concentration resulting in smaller packages.

Enironmental - reduce

- Using fewer toxic chemicals in the product and its packaging.
- Utilizing modes of shipping requiring less packaging and use of repairable pallets by manufacturers.
- Using multi-layered, multi-material packaging → this usually makes the product non-recyclable (i.e.: composites, laminates).

Enironmental - reuse

- Reusing/refilling commercially and redistributing refilled products.
- Refilling by the consumer through dispensing systems at retail outlets.
- Reusing containers which have been standardized to assist in reuse applications.
- Refilling via a second package (i.e.: smaller, concentrated containers or larger family-size packages).

Enironmental - reuse

- Reusing in the home - INFREQUENTLY purchased, durable and distinctive containers (i.e.: butter jars that can later be used as cookie or candy jars).
- Reusing in the home - FREQUENTLY purchased containers (i.e.: margarine tubs).



<http://plotc81.blogspot.hu/>



Enironmental - recycle

- Recycling over and over back into its original packaging type (also known as primary or "closed loop" recycling).
- Recycling back into another recyclable, useful package/marketable product (also known as secondary recycling).
- Recycling back into another non-recyclable product (also known as "open loop" or tertiary recycling).



Composting

- Composting is the controlled aerobic or biological degradation of organic materials such as food and yard wastes.
- The resulting humus, a soil-like material, is used as a natural fertilizer, thereby reducing the need for chemical fertilizers.



Combustion/incineration

Combustion — the controlled burning of waste in a designated facility — is an increasingly attractive alternative for waste that cannot be recycled or composted.

Types:

- Mass-burn incinerators.
- Refuse-derived fuel incinerators.
- Modular combustors.



Landfilling

Even naturally biodegradable products may not degrade in today's landfill because of the lack of air and moisture that bacteria need to thrive.

Anaerobic degradation

Biodegradable polymers

Anaerobic degradation

The main form of degradation that occurs in landfills is anaerobic degradation or digestion.

In anaerobic degradation or digestion, microorganisms slowly break down solid waste — primarily organic based materials such as wood and paper — (in the absence of oxygen) into primarily carbon dioxide, methane, and ammonia.

Biodegradable polymers

Biodegradable polymers are derived from:

- replenishable agricultural feedstocks,
- animal sources,
- marine food processing industry wastes,
- microbial sources.



Eco-friendly Packaging

- Eco-friendly packaging ranges from bioplastic containers, stretch wrap, and filling, to natural cellulose foam.
- Many biodegradable plastics are made from plant sources, particularly corn, wheat and potatoes.
- Recycling packaging reduces the environmental impacts marginally.



**100%
natural
packaging**

Enironmental - DISADVANTAGES OF PACKAGING

- RESOURCE UTILIZATION:
 - Because packaging is composed of materials ultimately derived from Earth, it is a user of resources.
- ENERGY:
 - Because energy is required both to make packaging materials and to package, packaging is a net user of energy.
- LITTER:
 - After use, because they have no further use, packages are discarded in greenlands, streets, and waters to become temporary or permanent eyesores on the landscape.

Enironmental - DISADVANTAGES OF PACKAGING

- **SOLID WASTE:**
 - Used packaging that has not become litter fills our dumps which reportedly are in short supply.
- **WASTE:**
 - Packages such as plastic or paperboard hanging at checkout counters are much larger than the products contained and, therefore, represent a major waste of packaging resources.