

## LECTURE NOTES

For Environmental Health Science Students

# *Sanitary Construction II*



**Ethiopia Public Health  
Training Initiative**

Esayas Alemayehu  
Tadesse Kassie

Jimma University

In collaboration with the Ethiopia Public Health Training Initiative, The Carter Center,  
the Ethiopia Ministry of Health, and the Ethiopia Ministry of Education

2003



Funded under USAID Cooperative Agreement No. 663-A-00-00-0358-00.

Produced in collaboration with the Ethiopia Public Health Training Initiative, The Carter Center, the Ethiopia Ministry of Health, and the Ethiopia Ministry of Education.

**Important Guidelines for Printing and Photocopying**

Limited permission is granted free of charge to print or photocopy all pages of this publication for educational, not-for-profit use by health care workers, students or faculty. All copies must retain all author credits and copyright notices included in the original document. Under no circumstances is it permissible to sell or distribute on a commercial basis, or to claim authorship of, copies of material reproduced from this publication.

©2003 by **Esayas Alemayehu and Tadesse Kassie**

All rights reserved. Except as expressly provided above, no part of this publication may be reproduced or transmitted in any form or by any means, electronic or mechanical, including photocopying, recording, or by any information storage and retrieval system, without written permission of the author or authors.

*This material is intended for educational use only by practicing health care workers or students and faculty in a health care field.*

## Preface

This lecture note is designed to meet the needs of students and instructors to some extent who are engaged in pursuing the Sanitary Construction II course in various universities and colleges administered by the Ministry of Education of Ethiopia. Text books in this specific area are scarce, learning materials few, and usually don't suit the objectives of the course for environmental health students. For these reasons and of course others, preparing such a lecture note has an overriding importance.

The lecture note is assumed to be used by a health center team, more specifically by the Environmental Health Team. The Environmental Health Team of the given health center can be represented by Sanitarians and/or Environmental Health Officers.

This lecture note consists of 6 chapters. The main theme of the chapters is on preliminaries and masonry construction as applied mainly in rural areas for water and sanitation providing by using locally available materials.

This lecture note is not intended to substitute text books or any other reference materials. However, the attempt is to show clearly that it is the right time to consider the production of student centered and problem based teaching materials.

## Acknowledgments

We would like to thank The Carter Center for the initiation to prepare this lecture note. We are also indebted to staff of the school of Environmental Health for reviewing the manuscript and providing constructive suggestions. Our final gratitude goes to Ato Mamo Wubeshet for reviewing the manuscript and providing invaluable comments.

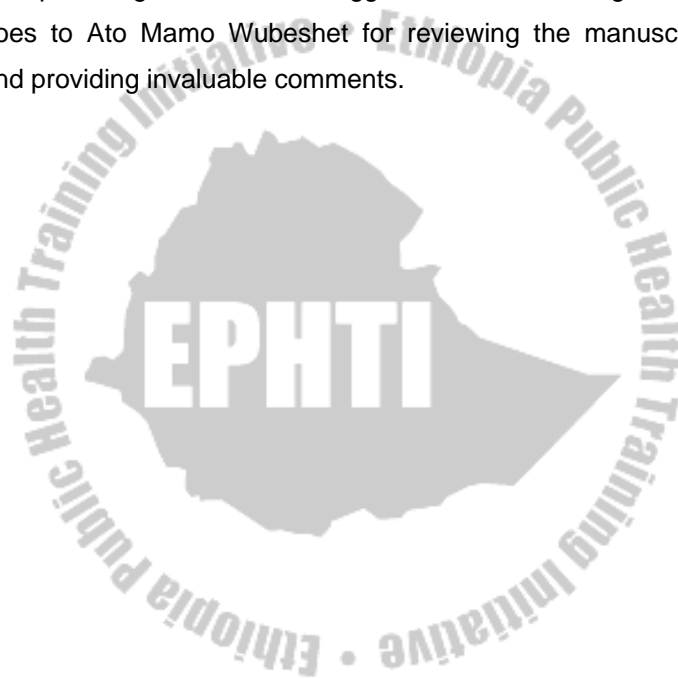

## Table of Contents

Preface	i
Acknowledgement	ii
Table of Contents	iii
List of Tables	v
List of Figures	vi
<b>CHAPTER ONE – MASONRY HAND TOOLS</b>	<b>1</b>
1.1 Laying Tools	1
1.2 Straightening Tools	2
1.3 Measuring and Marking Tools	6
1.4 Cutting Tools	8
1.5 Finishing Tools	9
1.6 Site Tools	11
1.7 Site Equipment	12
1.8 Tools for Measuring and Metering Angles	16
Review Questions	19
<b>CHAPTER TWO - BUILDING PRELIMINARIES</b>	<b>20</b>
2.1 Site Selection	20
2.2 Location Plan	22
2.3 Working Drawing	22
2.4 Plot and Site Clearing	23
2.5 Setting Out	24
2.6 Profiles	28
2.7 Setting Out on Uneven Ground	29
Review Questions	31

<b>CHAPTER THREE - MASONRY WORK</b>	32
3.1 Stone Masonry	32
3.2 Brick Masonry	36
Review Questions	48
<b>CHAPTER FOUR - BINDING MATERIALS: MORTAR AND CONCRETE</b>	49
4.1 Binding Materials	49
4.2 Mortar	52
4.3 Concrete	68
Review Questions	82
<b>CHAPTER FIVE - ESTIMATING AND COSTING</b>	83
5.1 Method of Estimating	85
5.2 Work Specification (main items of work)	87
5.3 Units of Measurement of Metric System	90
5.4 Estimation of Construction Cost	91
5.5 Summary	105
Review Questions	108
<b>CHAPTER SIX - ROOF IN GENERAL</b>	109
6.1: Roof Types	109
6.2: Size of Roof	110
6.3: Construction Details	114
6.4: Roof Covering	118
Review Questions	124
References	125

## List of Tables

Table 3.1 Thickness of wall standard brick	36
Table 3.2 Width ( thickness ) of walls with traditional bricks	37
Table 4.1 Quantities of materials required to make 1m <sup>3</sup> of various mortar mixes	55
Table 4.2 Internal dimensions of measuring boxes up to a capacity of 1m <sup>3</sup>	61
Table 4.3 Material required for 100m <sup>3</sup> concrete of different proportion	70
Table 4.4 Spacing of bars in slab thickness span of slab and diameter of the bar	76
Table 5.1 Details of measurement form	86
Table 5.2 Abstract of estimate form	86
Table 5.3 Units of measurement in metric system	91
Table 5.4 Quantitative descriptions of materials and labor spent for the mentioned projects	105
Table 5.5 Unit price of materials and labor	106
Table 5.6 Total cost of each system with contingency	106
Table 5.7 Summary price	107

## List of Figures

Figure 1.1 Laying tools	2
Figure 1.2 - 1.10: Straightening tools	5
Figure 1.11 - 1.15: Measuring and marking tools	8
Figure 1.16 - 1.17: Cutting tools	9
Figure 1.18 - 1.20: Finishing tools	10
Figure 1.21 - 1.28: Site tools	12
Figure 1.29 - 1.37: Site equipment	15
Figure 1.38 - 1.42: Try square	16
Figure 1.43 - 1.50: Tools for measuring mitering angles and optional tools	18
Figure 2.1: Location plan	25
Figure 2.2: 3 - 4 - 5 method	25
Figure 2.3: Lines x and y are equal in length	25
Figure 2.4: Cutting out the lines and marking the ground	25
Figure 2.5: Pegging of the foundation	27
Figure 2.6: Using the large square	27
Figure 2.7: Marking the positions of the foundation on the ground	29
Figure 2.8: Positions of the profile boards	29
Figure 2.9-2.13: Setting out	31
Figure 3.1: Rubble stone masonry	31
Figure 3.2 - 3.5: Ashlar masonry	34
Figure 3.6: Technical terms illustration	40



Figure 3.7: Stretcher bond	41
Figure 3.8: Header bond	41
Figure 3.9: Queen and king closers	41
Figure 3.10: Half - brick bonding	42
Figure 3.11: English bond	43
Figure 3.12: Flemish Bond	43
Figure 3.13: Align brick with the marks	45
Figure 3.14: Check correct height	45
Figure 3.15: Level the brick	45
Figure 3.16: Plumb the brick	45
Figure 3.17: Set the block on the mortar	46
Figure 3.18: Check the height	46
Figure 3.19: Plumb and level the brick	46
Figure 3. 20: Lay the second brick	46
Figure 3.21- 3.22: Laying the first course & Filling up the cross joints	47
Figure 4.1: Sand and cement	62
Figure 4.2: 'Dry mix' 3 times	63
Figure 4.3: 'Wet mix' 3 times	63
Figure 4.5 - 4.6: Formwork	78
Figure 6.1: Lean - to roof	110
Figure 6.2: Pent roof	110
Figure 6.3: Gable roof	110
Figure 6.4: Hipped roof	110
Figure 6.5: Roof pitch	111
Figure 6.6: Effective length of the sheets	112

Figure 6.7: Technical terms	113
Figure 6.8: Details of lean - to roof	114
Figure 6.9: Ordinary pent roof	116
Figure 6.10: Details of gable roof	118
Figure 6.11: Number of covering sheets	121
Figure 6.12: Number of sheets	123



# CHAPTER ONE

## MASONRY HAND TOOLS

### Learning Objectives

At the end of this chapter, students will be able to distinguish between and describe laying, straightening, measuring and marking, cutting, finishing and site tools.

There are various types of masonry hand tools used by masons. The most available and important ones are divided into laying tools, straightening tools, measuring and marking tools, cutting tools, finishing tools and site tools. These kinds of tools are further specified and mentioned below.

### 1.1 Laying Tools

#### The trowel:

Of the tools that a block layer uses, the brick trowel is by far the most important one, for it is almost continuously needed during the building construction. Its main function is to pick up the mortar and to spread to an even thickness in preparation for laying the blocks or bricks. And it is also needed for

trimming of bricks or blocks and for any work where mortar or concrete is worked up.

The long narrow – bladed trowel shown in fig 1.1 is very popular and it is most frequently used for laying blocks and troweling floor screeds. This trowel consists of a wooden handle (a) connected by a ferrule (b) to the shank (c) which joins the steel blade (d). The size of the blade ranges from 23 to 36 cm in length, while the width varies from 9 – 13 cm. the extended axle line of the handle (e) should line up with the tip of the blade in order to provide the best handle. When you buy a trowel, make sure that the blade is of good quality steel.

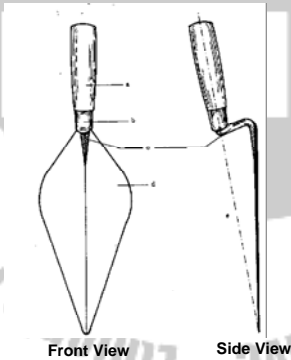

Fig 1.1. The trowel (Source: Rural Building Course, Volume 1 – 2, 1995)

## 1.2 Straightening Tools

These are spirit level, plumb bob, mason line, and straight edge.

### **1) Spirit level:**

These are wooden or metal straight edge specially fitted with plastic tubes containing spirit and a bubble of air. These tubes are set into the right edge so that when it is placed across two points which are level to each other, the air bubble will be exactly in the center of the tube. This position is clearly marked with lines inside the tube (figures 1.2 & 1.3). In similar way, a tube is set in the straight edge to read with level held vertically, which enables you to plumb members over short distances.

To level a longer horizontal distance you cannot use a straight edge with a level. Instead you have to use a water level, which will be explained later. To level a vertical distance, which is longer than your straight edge, you can use your plumb bob.

### **2) Plumb bob:**

This tool consists of a solid brass or metal cylinder with a pointed end, which is attached to a suspended line so that its tip is always pointing vertically down. The main use of the plumb bob is as a more accurate replacement for vertical spirit level and also to transfer down vertically in marking.

### 3) Mason line:

When building up walls between two quoins we employ the mason line, which is approximately 30 meters long, to ensure that the courses are straight and at the correct height (fig 1.4). The line is tightened between two nails driven into the bed joints. Mason lines are also used for setting out buildings, lining out frames for doors and windows and many other purposes where a straight line is needed for a guide over longer distances. Instead of nails, so called line bobbins may be used. These are hard wood blocks made to the size and shape indicated in fig 1.5. The line is stretched between opposite quoins, passed through the saw cut of each bobbin and wrapped around the projecting screws. Line bobbins are preferred to nails, as they are easily adjusted to the required level and no holes needed to be made in the bed joints. In addition to the mason line, a tingle plate must be used if the distance between the quoins becomes too great and the line starts to sag. A tingle plate is made from thin metal and it is used to support the line in the middle to prevent sagging. The tingle plate must be set at the correct height (fig 1.6). A tingle plate can easily be made from a piece of roofing sheet or any other sheet metal. Sometimes a piece of stiff paper is used for this purpose. If the line breaks, it should be spliced and not tied with a knot, because a line full of knots will not be straight.

#### 4) Straight edge:

This is a planned piece of wood which should be well seasoned and dry to prevent it from bending and twisting. The dimensions of a straight edge are usually 2 to 2.50 m long, 7.5 cm wide and 2.5 cm thick; both edges must be perfectly straight and parallel (fig 1.7). The straight edge is employed for testing masonry work either alone or in conjunction with the spirit level (fig 1.8). Some straight edges are marked off with saw cuts to the required gauge; that is one division is equal to the height of a block (brick) plus the joint (fig). Don't allow a straight edge to dry out in the sun or to be soaked in water as this may cause it to bend or twist (fig 1.10). When you are finished using it, hang the straight edge in a protected place to keep it straight.

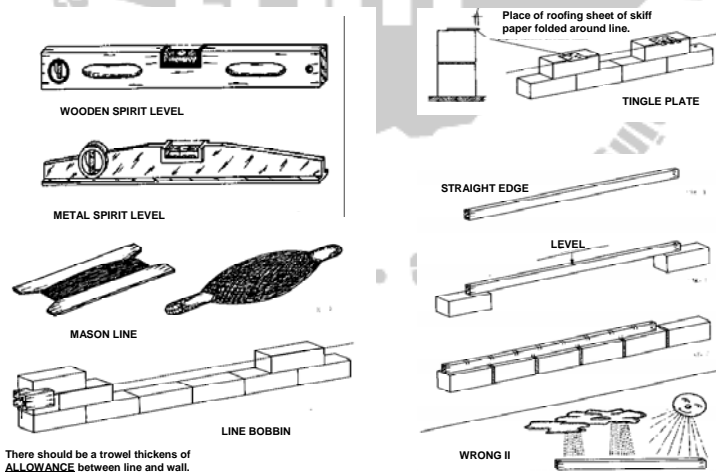

Fig. 1.2 – 1.10: Straightening tools (Source: Rural Building Course, Volume 1–3, 1995)

## 1.3 Measuring and Marking Tools

### 1) Folding rule:

The four – fold rule shown in fig 1.11 is made of four wooden, plastic or metal pieces which are held together by special hinges. It is one meter long and used on both sides into millimeters and centimeters. It is used to find and check measurements as well as to mark out the work. To make the rule operate more smoothly and last longer, put a drop of machine oil in the joints.

### 2) Zig – zag rule

A zig – zag rule is similar to a folding rule (fig 1.12). It is made out of the same materials but from pieces which are 20 cm long. As the hinges are different from those of the folding rule, be careful not to break it when opening and closing it. They come in lengths of 100 – 200 cm. When measuring with the folding or the zig – zag rule, one must make sure that the rule is completely opened and straight. It is then hold parallel to an edged, or at right angles to a face. If this is not done, the measurements you get will always be a little different from the correct ones.



### 3) Pencils:

For marking on wood, a hard lead pencil (H or 2H) is best (fig 1.13). The point should always be kept sharp, because using a blunt pencil can result in an accuracy of up to 2 mm.

### 4) The mason square:

The mason square is made from steel (fig 1.14). Measured along the out edge, the short blade is 33 cm long and the long blade is 60 cm long. The blades are sometimes marked with mm, cm, and decimeter. The mason square is used for setting out right angles as at quoins, and for testing corners during plastering when using the square, held it either horizontally or vertically (not at an angle) to be sure of getting the correct angles.

### 5) The large square:

This square is made entirely from wood (fig 1.15). To construct this large square which is made at the building site, use the 3 – 4 – 5 method and nail the boards together securely. A brace over the two legs ensures that the square remains at the correct angle. The square is used to test larger right angles.

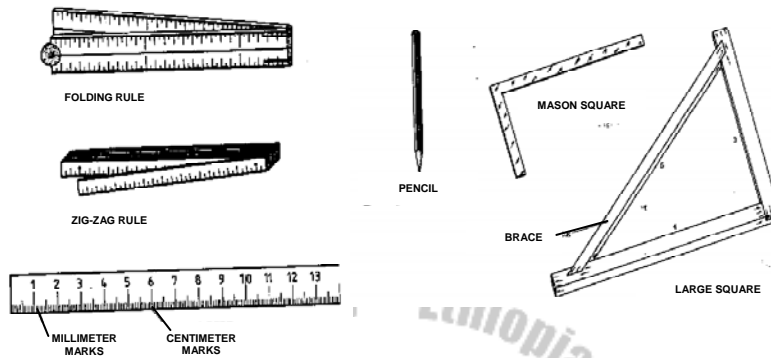

Figures 1.11 – 1.15: Measuring and marking tools (Source: Rural Building Course, Volume 1 – 2, 1995)

## 1.4 Cutting Tools

### 1) The block scotch:

This tool consists of a hard steel blade with two cutting edges, welded to the handle which is made of iron pipe (1.16). It is used for cutting all sorts of blocks and dressing out surfaces.

### 2) The pointed chisel (cold chisel):

This is a forged steel rod with a gardened cutting tip and striking end. Cold chisels are available in different sizes and are used together with a club hammer. Always wear your safety goggles when you use the chisel. They are used to cut

iron rods, pipes, metal sheets, stones, bricks etc. The club hammer has a heavy steel head with slightly rounded striking faces and it is used to strike cold chisels and to break stones into smaller size (fig 1.17).

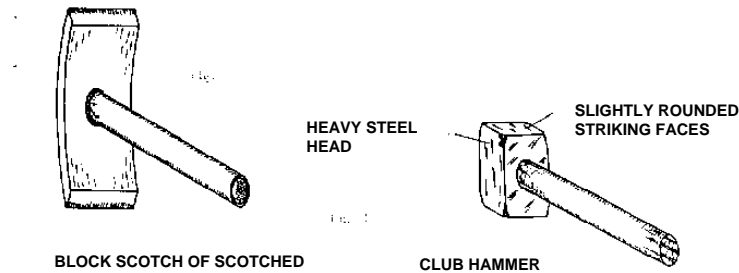

Figure 1.16 – 1.17: Cutting tools (Source: Rural Building Course, Volume 1 – 2, 1995)

## 1.5 Finishing Tools

Fig 1.18 shows a trowel of almost the same shape as the brick trowel mentioned earlier, but smaller in its dimensions. The pointing trowel is chiefly used for precision work such as finishing in general and the dressing of corners and edges in particular.

### 1) The big wood float:

This tool has a blade made of a soft wood. It is approximately 40 cm long and 25 cm wide. A handle made from hard wood

is fixed to it with screws so that the blade can be replaced when necessary (fig 1.9). Its main functions are to distribute an even thickness of mortar during plastering and to flatten concrete surfaces during floor construction.

## 2) The small wood float:

It is constructed in the same way as the big one but with smaller dimensions, being approximately 25 cm in length and 15 cm in width. It is used mainly to give the plaster and floor surfaces a smoother finish (fig 1.20).

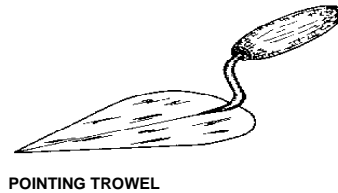

POINTING TROWEL

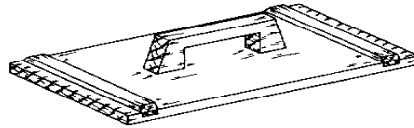

BIG WOOD FLOAT

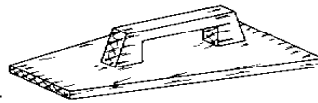

SMALL WOOD FLOAT

Figures 1.18 – 1.20: Finishing tools (Source: Rural Building Course, Volume 1 – 2, 1995)

## 1.6 Site Tools

### 1. Cutlass:

The cutlass (fig 1.21) is used for clearing the site and other general cutting work.

### 2. Hoe:

This farming tool is often used to excavate top soil (fig 1.22).

### 3. Shovel:

There are various types of shovel – like tools. The most common type is the one with a round – nosed steel blade of about 25 by 30 cm, connected to a short wooden shaft that has a “D” or “Y” shaped handle at the end (fig 1.23). Whether the shovel has a short or a long handle is a matter of personal preferences or local custom. The short – handled is more suitable for filling and moving purposes of light soil, while the long – handled is also better for loading and for mixing.

### 4. Pick-axe:

This digging tool consists of heavy steel with one pointed end with a chisel edge. The head is constructed to a wooden shaft (fig 1.24). The pick-axe is used during excavation to bread up hard rocky soils or loosen laterite etc.

### 5. Rammer:

Are either made entirely out of wood or they have a wooden handle attached to a metal or concrete head (fig 1.25 & 1.26). They are used to compact soil or concrete.

## 6. Hacksaw:

Is a hand saw used for cutting metals like iron rods, pipes, binding wires, etc. it consists of a steel blade tightly stretched in a metal frame. The blade is removable and other blades can be fixed in the frame for cutting materials (fig 1.27).

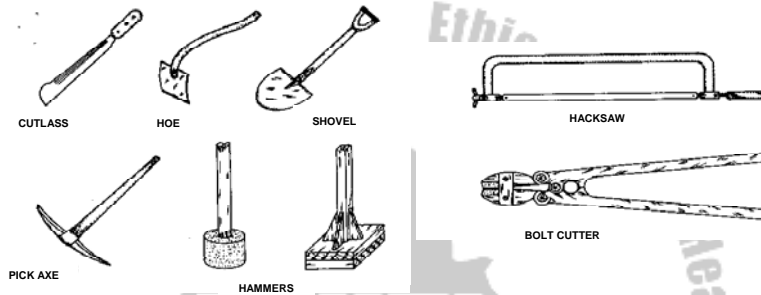

Figures 1.21 – 1.28: Site tools

(Source: Rural Building Course, Volume 1 – 2, 1995)

## 1.7 Site Equipment

### 1) Screen:

is a rectangular frame with a wire mesh built into it for separating impurities or stones from sand (fig 1.29). A well – equipped building site will have two different screens; a larger mesh to separate to stones of convenient size and a smaller one of sieve sand that will be used for plastering.

**2) Bucket:**

are open containers that can be made from different materials like rubber, plastic, or galvanized iron (fig 1.30). The average bucket (size no. 28) has a volume of 10 liters and is used mainly for carrying water.

**3) Rope:**

used on the building site are usually made from hemp or nylon. Nylon ropes have a tendency to stretch when they are under strain, and this must be taken into consideration when you use this kind of rope during construction work.

**4) Wheelbarrow:**

is steel or wooden container with single steel or rubber typed wheel in front. It is lifted and pushed forward by means of two handholds attached to the frame (fig 1.32). The bending bar is used to do the actual bending. This is a key shaped tool with a slot in one side into which the rod fits. Each different diameter of rod needs its own bending bar. If a suitable bending bar is not available, a pipe can be used to do the job (fig 1.33).

**5) Water level:**

used for setting out levels on the site as well as to transfer and control levels over large distances. It consists of a transparent plastic tube filled with water (fig 1.34). The level of the water at one end of the tube (a) will be at exactly the same height as the level at the other end (b), provided that there is no air bubble in the tube and it is not buckled. The water level enables us to level over large distances with a high degree of accuracy.

If there is no transparent plastic tube available and some rubber hose can be found, the rural builder can take two glass bottles, knock out the bottoms and fit the bottle necks to each end of the hose. This apparatus is then filled with water until the water is seen in the bottles. Levels can be read as easily with this device as with any other water level (fig 1.35).

**6) Strike board:**

is made from well seasoned wood. They are similar to straight edges except that they are usually longer (fig 1.37). A strike board (a) is used to level off the screed on floors, or in the case of notched strike boards (b) to level off concrete before the screed is laid.



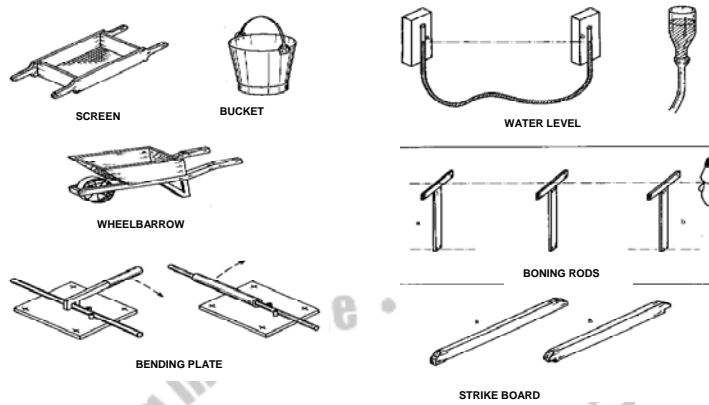

Figures 1.29 – 1.37: Site equipment (Source: Rural Building Course, Volume 1 – 2, 1995)

### 7) The try square:

is used for marking timber, and for testing right angles to make sure that they are correct. Its parts are (fig 1.38); the stock (a), the blade (b) and the stock face (c). The stock can be all metal or it can be made of hard wood with a brass stock face. The blade is made of steel. The angle between the stock face and blade is exactly 90 degrees.

### How to use the try square

To test the angles of work pieces and boards, place it as shown in the figures 1.39 & 1.40. Always use the try square with the stock against the face edge or the face side of the work piece when you are squaring or testing angles.

For marking timber, press the stock face against its edge or side of the work piece and use the blade to guide your pencil (fig 1.41 & 1.42).

Keep the pencil pressed to the blade, to avoid making double lines. Be careful not to drop the try square or use it carelessly. Any small movement of the blade will make it inaccurate.

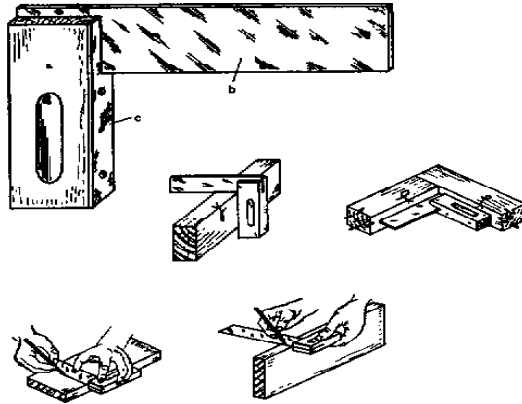

Fig. 1.38 – 1.42: try square (Source: Rural Building Course, Volume 1 – 2, 1995)

## 1.8 Tools for measuring and Mitering Angles

### 1) The meter square:

used to mark and test angles of 45 and 135 degrees. The blade is fixed at 45 degrees to the stock (fig1.43).

**2) The try and meter square:**

Combination of a try square and a meter square. The end of the stock where it meets the blade is cut at 45 (fig 1.44), so that square can be used for setting out and testing angles of 45 and 135, as well as 90.

**3) The sliding bevel:**

This is an adjustable square for marking out, testing and duplicating angles from 0 to 180 degrees. It has a stock and as slotted blade which can be adjusted to any angle and is held in place by a screw or a wiring nut (fig 1.45). A simple sliding bevel can be made by fixing two pieces of wood together with a nail or screw (fig 1.46). Another method is to use the first section of a folding rule.

**Other types of trowels:**

Fig 1.47 shows a triangular trowel, while fig 1.48 is almost rectangular. The rectangular type of trowel is also available with a rounded tip (fig 1.48a). All three types of trowel are useful in rural building and the decision of which are to use depends merely upon their availability and the builder's personal preference.

Fig 1.49 shows a heavier trowel designed specially for concrete work.

**Steel float:**

Consists of a thin rectangular blade about 12 cm wide by 28 cm long. There is a handle fitted to the back side of the blade (fig 1.50). This is a finishing tool used for smoothing surfaces such as floor and plaster.

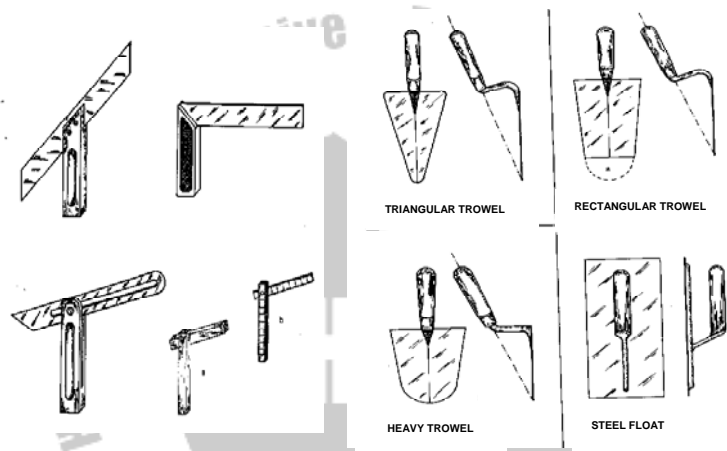

Figures 1.43 – 1.50: Tools for measuring metering angles and optional tools.  
(Source: Rural Building Course, Volume 1 – 2, 1995)

**Note to the teacher:** facilitate for the students to know all of discussed mason hand tools (as much as possible) in their work shop.

## Review Questions

1. What are the main groups of masonry hand tools?
2. Describe the subgroups of tools in each of the groups?
3. Observe and differentiate different masonry hand tools in your workshop.



# CHAPTER TWO

## BUILDING PRELIMINARIES

### Learning Objectives

At the end of this chapter students are able to:

- Understand the preliminaries of rural building construction
- Do site selection and prepare plan
- Set and lay out sit by different methods at different settings of ground (setting in even and uneven ground).

### 2.1 Site Selection

When choosing the location of the planned building; making a survey of any site from the point of hygiene or orientation (i.e., in relation to the points of the compass) would be the first job of the planner and of the builder.

Orientation of house (building) means fixing the position of the building direction wise in the site chosen. Site is the ground or place where a building is constructed.

In hilly areas, a building should be located at a place over which rain water may not flow. Ridge areas are better and safer for construction than valleys or depressions. The frequency, quantity and direction of rain fall in the area should be known thus less windows or doors should be provided in the effected walls. The walls will be protected with good plaster and paint. There should be enough projection of roof. Doors and windows should be provided with shades for protection against rain and sun.

For very cold areas excess of air or wind is not desirable. For warmer place more air should be permitted. For more air ventilation (i.e., windows) can be provided. For constructional safety, the gable or pent roof in areas with strong winds should not be in the direction of the wind. In areas with cold climates, keep more doors and windows in the east and west direction. In areas of warm climate, doors and windows should be facing north and south. In places lower than high flood level extra precautions should be taken to safe guard foundations against the action of flood waters. If possible site higher than the high flood should be preferred places; which are lower than water flow, should be avoided.

## **2.2 Location Plan**

When building a house or any other structure must have certain information available, in order to arrive at the best economical result. The basic information is the location, size and nature of the plot. This is contained in the location plan, which shows the plot and the immediate surroundings in scale. The scale can be 1:20 up to 1:1000 depending on the size of the project. The plan outlines the shape of the plot and the dimensions of its boundaries, as well as the location of the future building. It should also show the nature of the area, because it is very important to know whether the site is sloping or if the ground is uneven.

Roads, drive ways and the positions of the bigger trees are also marked on the location plan. When the site has been examined thoroughly and all the measurements and particulars have been obtained, the drawings for the house can be prepared.

## **2.3 Working Drawings**

The working drawings are the drawings which the builder uses before the construction starts and during the construction; to plan for materials requirements, to plan the work; and finally to carry out the construction according to the directions



continued in the drawings. The drawings include, plans, “cross section”, “elevations”, and detail “drawing”, they are all prepared in scales which are suitable to the particular drawing. The first three type of drawing have a scale of between 1:50 and 1:20.

**Note to the teacher:** please, let the students to refer the description of each of the above types of drawings.

## 2.4 Plot and Site Clearing

Once the planning work has been completed, the plot and site have to be prepared for the setting out. The location plan shows exactly from which areas the trees, bushes, grass and stones must be removed. The ground is leveled. The part of the plot which is cleared will be the actual site that the future building will occupy, including a space of about 5 m all round the building. One very important measure is to remove all the trees from the site area. If roots remain, they will sometimes grow again and might damage the structure. Clearing all the trees on the whole plot is not necessary. Beyond the 5 m clear space, as many trees as possible should be allowed to remain, because they will provide shade for the people using the building or living there.

## 2.5 Setting Out

Once the plot and site clearing is completed, the setting out can be done. At the beginning of any construction activity the work must be carefully set out. This is also known as pegging out or lining out. Setting out means to put pegs in the ground to mark out an excavation; or to mark on the floors to locate walls.

### 1) 3–4–5 method

The first line to be set out is the front line of the carcass (fig 2.1). A “carcass” is the building when it is structurally complete but other wise unfinished. In this case we mean that the front line marks the position of the outside face of the (future) unplastered wall. The lines of all the other walls are measured from this front line. If the building is rectangular, right angles are set off from the front line by using the 3 -4 – 5 methods. The second line to be set out is the line of one of the side walls of the carcass. This line intersects the front line at the corner of the future building. To make sure that this corner is a right angle, we use the 3 – 4 – 5 method.

- a. Measure a distance of 4 m along the front line starting from point A, and mark this on the line (point B) (fig 2.2).
- b. Measure a distance of 3 m along the second line, starting from the corner (point) and mark this distance (point C).

- c. Now take a line which is marked with a distance of 5 m, and stretch it taut from point B towards the line with the point C. keeping the end points of both lines steady (points A and B) and the lines taut; move the free ends of the side line and the 5 m line until the 5 m mark and the mark at point C meet each other. This is best done with two men, one at the end of each line.
- d. The corner angle must now be a right angle.
- e. Measure the required length of the side line and insert a peg at the end. Set out the opposite side line in the same way.
- f. If the setting out has been done accurately, the length of the black line between the two pegs should be equal to that of the front line.
- g. Make a further check by measuring the diagonals, which must be equal (fig 2.3).

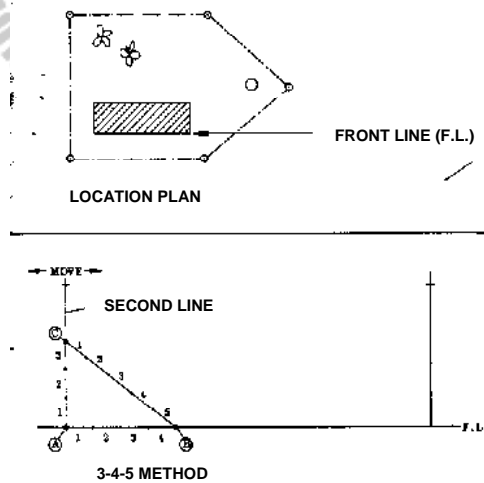

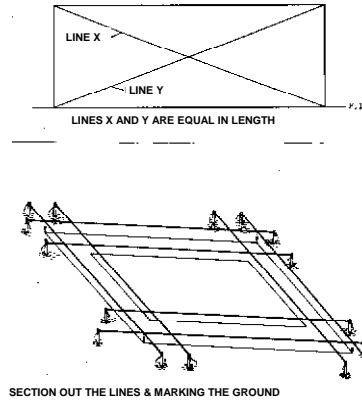

Fig. 2.1 – 2.4. Cutting out the line and marking the ground. (Source: Rural Building Course, Volume 1 – 2, 1995)

## 2) Lining out

Once the positions of the corners and the distances between them are determined, the positions of the foundations, footings and all as well as their thickness must be marked. A simple example of setting out and marking a foundation is shown in fig 2.4.

## 3) Direct marking

Small buildings or small extensions of houses may be marked directly on the flat ground, provided that the excavation work can proceed immediately and can be quickly completed, so that the marking need not be repeated (fig 2.5)

In this procedure, the setting out must be done in stages.

- a. Mark the position and width of the foundation directly on the ground, and dig the trenches immediately.

- b. The next step is to level the bottom of the trenches and to peg off the foundation depth (fig 2.5).
- c. After the foundation concrete (or stone) is cast, set out the footings directly on the surface of the foundation (fig 2.6) and build them to the required height.
- d. When the footings and hard core filling are complete, set out the plinth course on the footing.

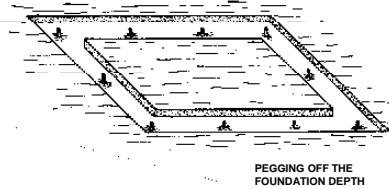

Fig 2.5: Pegging of the foundation

(Source: Rural Building Course, Volume 1 – 2, 1995)

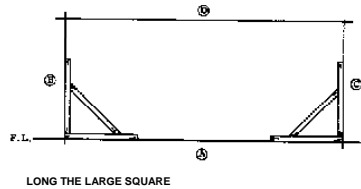

Fig 2.6: The large square

(Source: Rural Building Course, Volume 1 – 2, 1995)

#### 4) Using the large square

The large square, described in the masonry hand tools, may be used to set out and mark off the position of inside walls. This is less time-consuming than using the 3 – 4 – 5 method. Place the large square on the ground with one side along an

already determined line, and mark off the corner on the other side (fig 2.6). Not only the whole building, but also each room in the building must be checked for squareness by comparing the diagonals, which have to be equal.

## 2.6 Profiles

When the positions of the corners of the building are known, and the distances between them, then we can mark the positions and widths of the foundations and of the footings and plinth course. A profile is a simple, temporary structure which maintains the correct locations of the various marks.

The profile consists of a board nailed flat wise on top of two pegs which are set in the ground, at a height of about 60 cm (fig 2.7). This height is necessary to lift the line well above the footings, so that later the plinth course can be marked from the profile. If the soil is too hard to drive the wooden pegs, iron pegs designed to receive a profile board can be used.

At the corners of the building, two boards are used, to mark in two directions (fig 2.8). To mark off the dividing walls, one board is used at each of the future wall (fig 2.9).

Permanent divisions are marked on the boards to indicate the width of the foundations and the thickness of the rising walls. The marks may be either saw-cuts or short nails, so that lines can easily be fixed to them as needed.

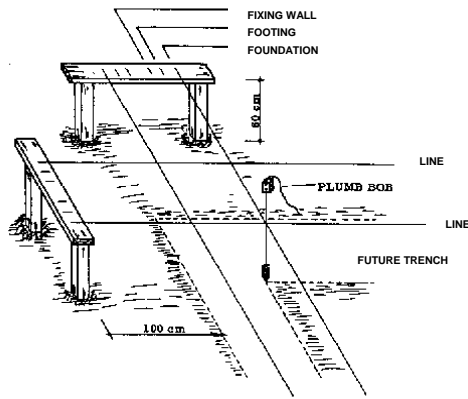

Fig 2.7: Marking the positions of the foundation on the ground (Source: Rural Building Course, Volume 1 – 2, 1995)

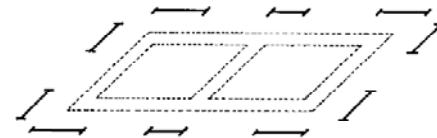

Fig 2.8: Positions of the profile guards (Source: Rural Building Course, Volume 1 – 2, 1995)

## 2.7 Setting Out on Uneven Ground

Setting out on uneven ground, particularly distances, requires you to apply some simple geometry. When we measure distances in setting out, we are actually looking for the horizontal distances between two points (fig 2.9, x). We don't measure the distances along a slope, because the house we

want to build will not slope, it will have level floors and walls. Since the ground is not flat, and the points are at different heights (point A is lower than point B), the horizontal distance between them has to be measured indirectly. Fig 2.10: shows two men trying to measure the distances between pegs A and B along uneven ground. Their result cannot be correct because the line they are holding is neither straight nor is it horizontal (measure "x" and compare it to the length of their line). The men in fig 2.11 also fail to get the correct measurement. The line is straight taut and is therefore straight, but it is still not horizontal (measure "x" and compare it other length of their line). In order to find the horizontal length "x" and line or tape measure has to be held horizontally and stretched taut so it is straight. Both ends of the line are kept vertically above the pegs A and B by means of plumb bobs (fig 2.12). This method is good rough method for short distances. For very large distances, the use of boning rods can be used to make sure that the different steps are in line and the total length measured in straight (fig 2.13). With the boning rods and a water level, you can also make sure that the whole distance is horizontal.



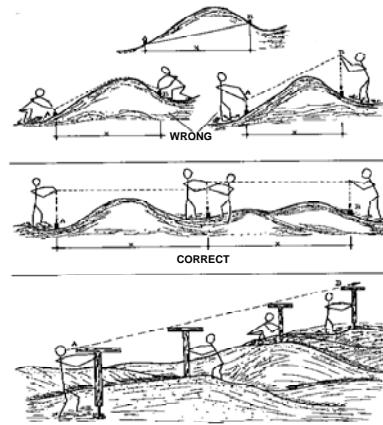

Figures: 2.9 – 2.13: Setting out

**Note to the teacher:** students should practice site selection, location, drawing and setting out foundation and others during their practical session.

### Review Questions

- 1) What is the difference between setting out and laying out?
- 2) What methods do you utilize for setting out at uneven ground?

# CHAPTER THREE

## MASONRY WORK

### Learning Objectives

At the end of this chapter, students will be able to:

- Understand and know how to construct masonry using different materials
- Understand different types of stone and brick masonry and apply
- Know and practice stone and brick laying in workshop and field.

Masonry means construction of stone (brick) joined with or without mortar (i.e., dry stone wall or open joints).

### 3.1 Stone Masonry

Several kinds of stone, both natural and artificial, are used in structures such as buildings, walls, foundations, etc. Natural stones used for construction include, sand stone, lime stone, granite, basalt, etc. Artificial lime stone is available in many areas.

## I. Types of stone masonry

A. **Rubble stone masonry:** - This is the most common type of masonry used in many parts of the world. The stones are roughly shaped by the masons, and the resulting wall is similar to that shown in fig. 1, which is laid in regular courses or at random with mortar joints. The mortar used may be mud mortar, cement mortar or lime mortar. For estimate purposes, this type of masonry is approximately 35% mortar and 65% stone.

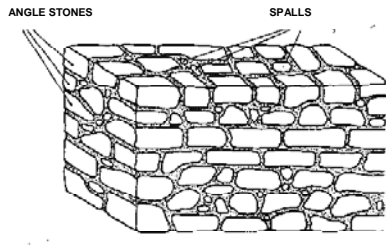
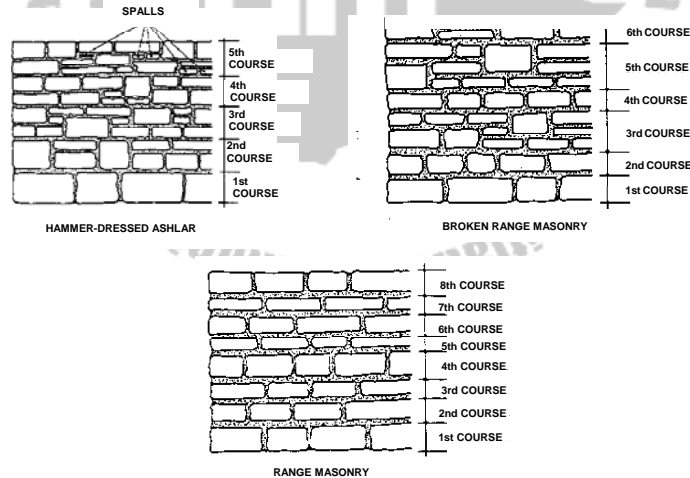

Fig 3.1: Rubble stone masonry. (Source: Rural Building Course, Volume 1 – 2, 1995)

B. **Dressed-stone masonry:** Also known as “ashlar masonry”. In this type of masonry, the stones are carefully cut to rectangular dimensions, making “stone bricks”. Such masonry requires skilled masons, and much time and labor. Ashlar masonry is approximately 30% mortar and 70% stone. There are four different types of ashlar masonry, depending on how much dressing is done and how the stones are put together. These are:

- Rough stone masonry
- Hammer – dressed ashlar masonry
- Broken range masonry &
- Range masonry.

These are listed according to the increasing amounts of stone dressing and stone arrangement required for each method. For example, rough stone masonry consists of natural stones which are shaped only slightly along their bed faces, or not shaped at all. As in rubble masonry, regular stones are not seen here in rough stone masonry because of the irregularly shaped stones (fig 3.2). Where as in range masonry; the accurately squared stones are laid in courses, and each course is uniformly thick throughout its length. However, the courses are not all necessarily all the same thickness (fig 3.5).



Figures 3.2 – 3.5: ashlar masonry  
(Source: Rural Building Course, Volume 1 – 2, 1995)

## **II. Thickness of stone wall**

The thickness of the wall depends to a large extent on the material and masonry technique (i.e., either rubble or dressed stone masonry). When using easily worked material the thickness may be less. Local masons can usually build walls in stone masonry to 30-50 cm thick. In any case, if the height of the wall is 3 m or more, a wall thickness of 45-50 cm is quite common.

## **III. Stone preferences**

Basalt stone is used mainly for walls which are exposed to moisture, for example foundation walls, lining (casing in) of wells, pit latrines, septic tanks, soak away pits, cesspools, etc. While the more easily worked trachete stone is employed for all kinds of walls above ground, level (i.e., elevation walls). Other types of stones suitable for wall masonry are sand stone, granite, lime stones, slate. Stones should have faces for construction. Stones at the middle of the wall should have three faces:

- The side face to be seen straight
- The bottom face to rest leveled on the other stone and the top face to be convenient for the course
- Corner stones (quoins), which give strength to the wall, must have four faces

- Amorphous stones can be in between to fill gaps.
- Wall should be filled properly without vacancy.
- Stones for construction must properly over-lap i.e., the half body of one stone on the half body of another stone (see at coursed rubble and coursed ashlar bonds).

### 3.2 Brick Masonry

Bricks are usually locally manufactured, and are of various shapes and quality. The exact dimensions of local bricks should be obtained for making the estimated requirements. The total volume of brick masonry is approximately 25% mortar and 75% brick. The actual size of standard modular brick is 19 cm x 9 cm x 9 cm and its nominal size is 20 cm x 10 cm x 10 cm.

**Table 3.1:** Thickness of wall with standard brick

Wall	½ brick	1 brick	1 ½ brick	2 brick	2 ½ brick
Thickness of wall in cm	10	20	30	40	50

Actual thickness of wall with 1 cm mortar joint are 9 cm for ½ brick, 19 cm for 1 brick, 29 cm for 1 ½ brick, 39 cm for 2 bricks

and so on. But the thickness of wall is taken as multiple of 10 as given in the above table irrespective of the actual thickness for estimating number of bricks required for a given volume (or  $m^2$ ) of wall.

When the thickness of a wall is said to be  $\frac{1}{2}$  brick, it means that the wall is made of a single brick. As for example, the length of the modular brick is 20 cm; half of its length is 10 cm. Therefore a thickness of  $\frac{1}{2}$  brick wall means half the length of full brick (or the width of a single brick). Similarly, when the thickness of a wall said to be 1 brick, is that two bricks are laid side by side each 10 cm wide that make up 20 cm wide wall (10 cm + 10 cm = 20 cm), which is equal to the length of one full brick. The actual size of traditional brick is 22.9 cm x 11.2 cm x 7 cm and its nominal size is 22.9 cm x 11.4 cm x 7.6 cm.

**Table 3.2** Width (thickness) of walls with traditional bricks

Wall	$\frac{1}{2}$ brick	1 brick	1 $\frac{1}{2}$ bricks	2 brick	2 $\frac{1}{2}$ brick
Thickness of wall in cm	11	22.9	34.3	45.7	57.1

### **I) Thickness of brick wall**

In general for one story residential building one brick, (i.e., 20 cm if with a modular brick and if traditional brick is used, the thickness in 22.9) thick wall is sufficient. If for example the brick size in your locality is 22.9 cm x 11.4 cm x 7.6 cm, and if you decide to build a wall of one brick thick, it means that the thickness of your wall is 22.9 cm, which means two bricks each 11.4 cm wide are laid side by side with 0.1 cm apart.

- Walls longer than for meter length (span) should be thicker than one brick.
- Partition walls may be half brick thick (i.e., single brick either of 10 cm, or 11.4 cm wide or depending on the brick size locally available.
- Minimum thickness of stone masonry wall may be 30 cm.

### **II) Technical terms used in brick work**

- Course: This is the term applied to each layer or row of bricks (blocks), with the bed joint included fig.3.6, next page. The thickness of each course is one brick plus one joint of mortar.
- Quoin: The quoin is outside corner of a wall or the external angle on the face side of the wall (fig 3.6).
- Joint: The horizontal joints between the bricks are bed joints and the vertical joints are called cross joint. Bed is



the under surface of a brick (block) or the mortar on which the brick is laid.

- Stretcher: if the bigger face of a brick is exposed i.e., when a brick is laid showing its long side i.e., 22.9 cm, the brick is called a stretcher (fig 3.6). This is the way most bricks are laid in rural building, and we say that the brick is laid edge wise. If a brick is laid flat wise, so it is actually showing the top face, it is also called a stretcher.
- Header: A brick is known as header when it is placed in a wall so that its smallest face (i.e., 11.4 cm) is exposed.
- Bats: are pieces of bricks, and are generally known as  $\frac{1}{2}$  or  $\frac{3}{4}$  bats, according to their fraction of a whole brick. The cut is made along the width, not along the length. A special brick (block) gauge may be used for marking off the different sizes.
- Queen closers: Is half the width but the same length and thickness of an ordinary (whole) brick. The cut is made along the length not along the width. They are placed next to the quoin header to obtain the lap.
- King closers: are bricks which are cut obliquely so that one end is half the width.
- Angle brick: this is the brick, which actually forms the corner in each course.
- Toothed end: The form produced at the end of a wall by recessing every other course by half brick (block) in order that the wall may be extended later using the same bond.

- Racking back: as an alternative to tothing; the end of a wall may be set back half a block (brick) at each course. This is also done so that the wall may be extended using the same bond.
- Foundation: the base, usually concrete (or stone, block, brick), on which the building rests. It is usually set below ground level, and is the only part of the building in direct contact with ground.
- Footings: the courses laid directly on top of the foundation
- Plinth course: the edge wise course laid on top of footing
- Rising wall: the edge wise course which build up the rest of the wall

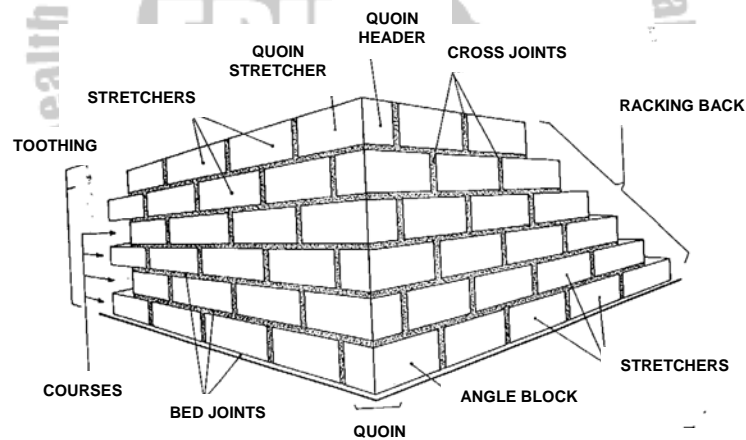

Fig 3.6: Technical terms by illustration  
(Source: Rural Building Course, Volume 1 – 2, 1995)

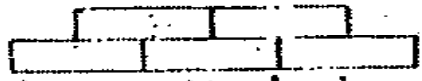

Fig 3.7: Stretcher bond

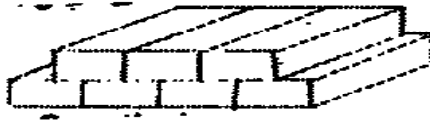

Fig 3.8: Header bond



Fig 3.9: Queen and king closers

### III) Bond

It is a system of laying bricks (blocks), one upon another, so that the pressure of the weight is equalized. The practice of brick laying (block laying) requires a complete understanding of the correct arrangement of the bricks (blocks) forming a wall. This correct arrangement of bricks regardless of the methods is known as bonding.

The bricks are placed so that they overlap each other and care must be taken to ensure that as far as possible no vertical joint is immediately above another vertical joint in the course below.

The simplest form of bonding is that where all the bricks (blocks) are laid down as stretchers, each brick overlapping the one below by half its length. This form of bonding is only suitable where a two-brick thickness of the wall is sufficient.

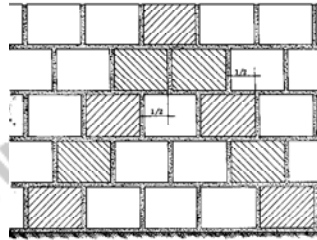

Fig 3.10: Half – brick bonding

(Source: Rural Building Course, Volume 1–2, 1995)

### Methods of bonding

In brick (block) construction, there are a number of recognized methods of bonding: English bond, Flemish bond, stretcher bond, header bond, English garden wall bond, and Flemish garden bond. While the chief bonds used in house construction are English, Flemish and garden-wall bond.

- **Stretcher bond:** the bricks in all courses are as stretchers, i.e., the brick is laid with its length laying along the length of the wall. It is suitable for use in small houses or as a partition walls and half – timbered work.
- **Header bond:** is the usually used for footings, cornices and for rounding curves (arcs). A header is a brick with its width running in to the all.

- **English bond:** this bond consists of alternative courses of headers and stretchers. The center of any stretcher is in line with the center of the header in the courses above and below. Headers are laid above and below the middle of each stretcher, and to always to form these particular vertical joints on the wall face in their correct order a smaller brick, called a quoin closer, is inserted next to the quoin header, so as to start the regular strongest of all bonds, because there are no straight joints, except the width of about 3/8 of an inch, the vertical joints intersect.

- **Flemish bond:** this bond consists of alternative headers and stretchers in the same course. The centre of any stretcher is in line with the center of the header in the course above and below.

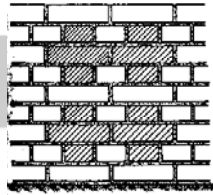

Fig 3.11: English bond (Source: Rural Building Course, Volume 1 – 2, 1995)

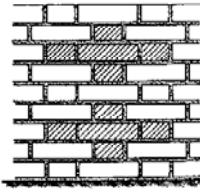

Fig 3.12: Flemish bond (Source: Rural Building Course, Volume 1 – 2, 1995)

## **Brick laying procedure**

### **Quoins**

When external walls are constructed the corners or quoins are built first, to a height of 91 cm, extending the base of the corner along the wall which is then racked back as the construction proceeds. The walling between the courses is completed later, course by course. The corners, so great care must be taken to build them properly, determine the accuracy of the wall.

A quoin is constructed in the following manner: Bricks are sometimes not correctly shaped, so the first brick or angle brick must be chosen carefully so that all its faces are square to each other.

As you lay the brick, stand close to the foundation with your head vertically over the brick. You should be able to see that both outer faces of the brick are aligned with the mark below. After this, the brick has to be accurately leveled and plumbed. Use the straight edge with gauge mark to ensure that the brick is laid at the correct height. Hold the straight edge of the brick should correspond to the edge mark.

Now you have to make certain that the header face and the stretcher face are truly vertical. To do this hold the spirit level against one face about 5 cm from the corner, keeping it in this position while with your other hand you move the brick until the bubble in the tube is centered. This operation must be repeated with other face of the brick.

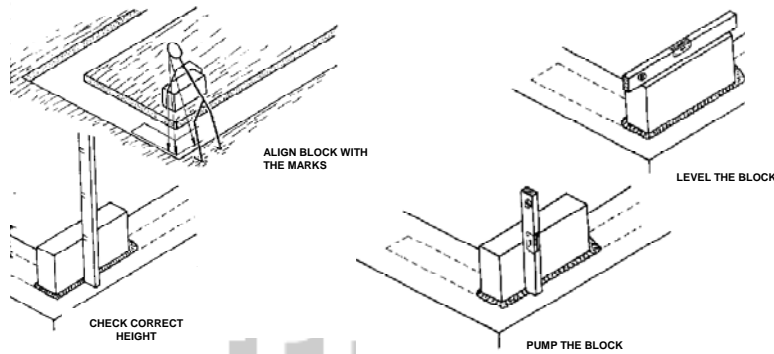

Fig 3.13-3.16 Brick laying procedures (Source: Rural Building Course, Volume 1 – 2, 1995)

Now lay several bricks in each direction between the corners. If the length between the two corners is too long, lay two blocks at an intermediate distances to start the first course of filling the wall between the corners.

### The first bricks

These are the bricks of the course to fill the gap between the courses. After you wetted the brick and the area where it is supposed to be set, spread the mortar. Set the brick

immediately onto the mortar bed and press it down firmly and evenly. The height is checked by comparing the height of the brick with the gauge marks on the straight edge. Next, plumb the block (brick) with the spirit level along the stretcher face and the header face. Lay the second brick at a distance of four building units and one joint away from the first brick. Hold the straight edge against the stretcher faces of the two bricks to make sure that they are in line.

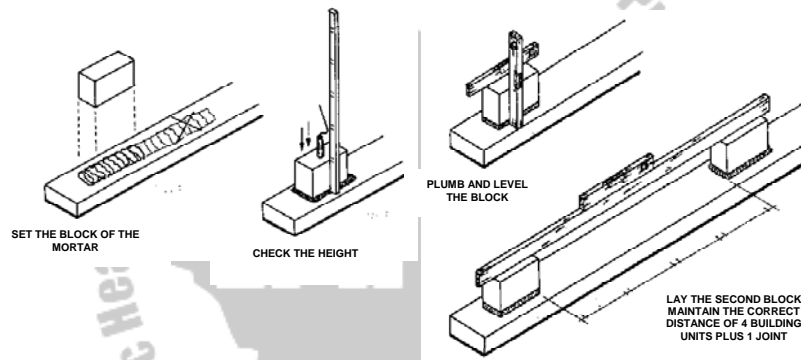

Fig 3.17 – 3.20: Set the brick on the mortar (Source: Rural Building Course, Volume 1 – 2, 1995)

### The first course

Because the first two bricks are in line and at the same height, you can complete the course without using the spirit level, only using the straight edge. Starting from either brick (but still working only on one side of the wall) more bricks are inserted between the first two bricks. Their height is adjusted by



placing the straight edge on top surfaces of all the bricks touch the straight edge equally, along their whole length.

Line out the course by holding the straight edge against the stretcher faces and moving the bricks until they touch it along their full length.

The next step is to fill the remaining open gaps between the bricks with mortar, thus forming the cross joints. This is done by closing the back of the gap with the aid of a small wooden float while care fully pushing the mortar down in the joint with trowel.

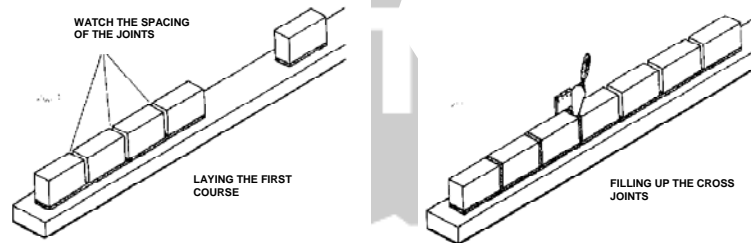

Fig 3.21 & 3.22: Laying the first course and filling up the cross joints (Source: Rural Building Course, Volume 1-2, 1995)

### The second course

Lay the first brick of the second course with its centre exactly above the first cross joint so that it overlaps both brick below equally.

The first brick of the second course is always a full brick laid above the first cross joint between two stretchers. This is known as the 1 – 2 rule.

**Note to the teacher:** students should practice in the workshop for the coming professional practice programme.

### Review Questions

- 1) Which type of masonry is best suited for rural settings?
- 2) What are different types of brick bond? Show by sketching them.
- 3) Define the following words: king and queen closure, quoin, foundation.

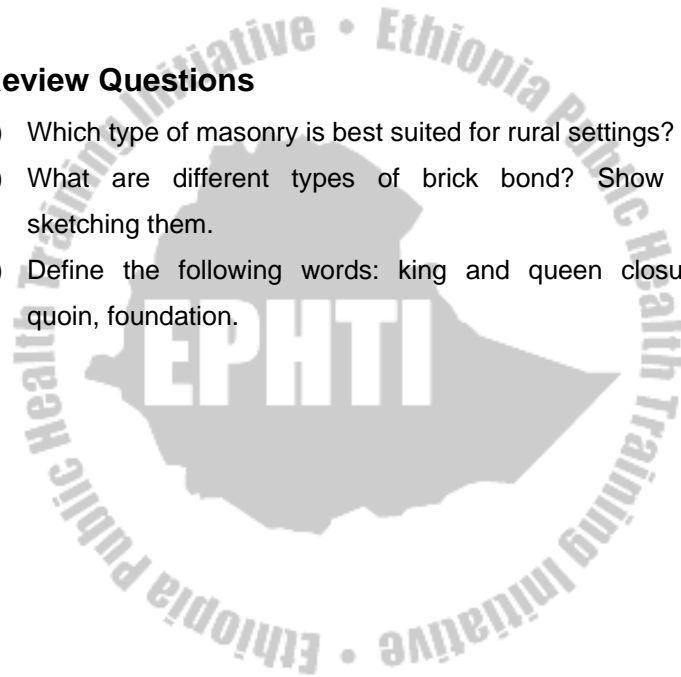

# CHAPTER FOUR

## BINDING MATERIALS: MORTAR AND CONCRETE

### Learning Objectives

At the end of this chapter students are expected to know

- Different types of binding materials
- Prepare binding materials
- Estimate materials (mortar, concrete) for different projects to be implemented in rural areas.

### 4.1 Binding Materials

1) **Lime:** is a very fine white powder, used in mixes for mortar, plaster and render. It is made from lime stone or chalk which is burnt in a kiln and becomes quicklime. One cubic meter ( $1 \text{ m}^3$ ) space occupies 900 kilo grams of lime (i.e., lime = 700 kgs/m<sup>3</sup>).

2) **Portland cement:** is a fine grey power. Among the various kinds of cements, it is the most commonly used as an

adhesive; gluing together sand, stone and brick. It is made of a mixture of chalk or lime stone and clay.

**Packaging of cement:**

- One liter of Portland cement weighs approximately 1.44 kilo grams
- One bag of cement equals 50 kgs (packed in the factory)
- One bag of cement (i.e., 50 kgs of cement) is equal to 35 liters (0.035 m<sup>3</sup>).
- One meter cubic (1m<sup>3</sup>) of cement equals 1400 kgs to 1450 kgs.

**Storage of cement:**

When storing cement at the project site, it should be stacked in a closely-packed pile, not more than 10 bags. Close packing reduces air circulation between the bags, which is good. The pile of cement should be raised on a plat form above the floor. The storage room should have as little air circulation as possible. Aged cement will form lumps. All lumps should be screened out of the cement, and no lumps should be used which cannot be easily crumbled by the finger. If the cement is old (i.e., field stored for more than 6 months), it must be used by increasing the amount in the mix by ½ - 1 parts (depending upon how lumpy it is).

**Water:**

Water in the cement mix serves for two purposes. First, to take part in the hydration (i.e., chemical reaction (i.e., between cement and water) reaction of the cement, and secondly, to make the mix fluid and plastic enough so that it can be easily worked and placed.

**Water quantity:**

Water is necessary for the hydration of the cement, but too much water added during mixing results in a weaker mortar or concrete. Therefore, no more water should be added than necessary to make the mix easily workable. The ideal quantities of water depend upon the amount of cement in the mix. The approximate amount of water needed in the mix (i.e., mortar or concrete mix) is  $\frac{3}{4}$  parts water per one part of cement (1:  $\frac{3}{4}$ ; cement: water) by volume. For example, if 1 liter ( $0.001\text{m}^3$ ) of cement is to be used in a mix of either mortar or concrete, 0.75 liter of water is needed. And if 2 liters ( $0.002\text{m}^3$ ) of cement is used in the mix, 1.5 (i.e., water = 0.75 liter x 2) liters of water are needed and soon.

## 4.2 Mortar

Mortar is a mixture of:

1. Cement and sand (known as cement mortar)
2. Earth and sand (known as mud mortar)
3. Lime and sand (known as lime mortar)
4. Cement and lime (known as cement lime mortar)
5. Cement, sand and lime (known as compo mortar)

The first two types of mortar has been discussed below, the fact that these products are commonly used in Ethiopia, giving special emphasis to “cement mortar”.

### I. Cement mortar

This sets quickly and develops great strength. It is used in proportions (mix ratio) of cement and sand. Widely used mixes are:

- 1:4 (cement: sand), for most purposes
- 1:3 (cement: sand), for plaster and finishing floor
- 1:5 (cement: sand), for wall plaster
- 1:2 (cement: sand), for 3<sup>rd</sup> coat plaster

### Sand:

It is used in both mortar and concrete. Proper sand is well-graded (i.e., containing grains of many sizes mixed together). Sand found in land deposits is known as “pit sand”. Sand

carried by water such as found along banks of rivers or lakes, is known as “river sand”.

Both types of sand are suitable for cement work, so long as they are well graded and clean. Sand containing clay, silt, salt, mica or organic material is not good, since such contaminants can weaken the strength of the cement if they are present in large quantities. Rinsing repeatedly with water can wash dirty sand.

**Bulking of sand:**

Dump sand that contains water will swell up and occupy a greater volume than dry sand. This is known as “bulking”. As a result, moisture content can increase the volume by 30%. Thus when using slightly damp sand, it is necessary to use an extra amount of sand in the mix if it is to be proportioned by volume. Its application will be illustrated in the following topics.

**Volume of mortar:**

The total volume of mortar is equal to the total volume of sand in the mix. The cement mixes with water to form a paste which fills in the voids in the sand. Thus, a 1:4 mix requires 100% sand and 25% cement; a 1:3 mix requires 100% sand and 33 % cement; a 1:2 mix requires 100% sand and 50% cement, etc.

The 25%, 33%, 50% etc, are known as “increments for wastage”. This is because of mortar may be wasted during measuring, mixing, using, etc. Therefore, we need to prepare surplus amounts of mortar in order to recover the wastage.

For example, you estimated that  $1\text{m}^3$  of mortar is exactly needed to plaster a wall. And the mortar mix is 1:4 (i.e., 1 part cement and 4 parts sand). If you prepare exactly  $1\text{m}^3$  mortar, it will not be sufficient for your job. You would face shortage of it as a result of wastage due to the reasons for wastage explained earlier. Therefore you should increase the  $1\text{m}^3$  mortar by adding 25% of it to it. Thus;

- the exact volume of mortar needed =  $1\text{m}^3$
- the volume of mortar we should we should prepare (including the wastage)
  - =  $1\text{m}^3 + 1\text{m}^3 [25\%]$
  - =  $1 + 0.25$
  - =  $1.5\text{m}^3$
- then, cement =  $1.25\text{m}^3 \times 1/5$ 
  - =  $0.25\text{m}^3$
- sand =  $1.25\text{m}^3 \times 4/5$  OR sand = volume of cement  $\times 4$ 
  - =  $0.25\text{m}^3 \times 4$
  - =  $1.0\text{m}^3$

Note: the percentage for increment is simply determined by noticing the mixing ratio used. For example, in a 1:4 mix



mortar, the percentage for increment is 25% which is determined simply by dividing 100 to 4 (i.e.,  $100/4$ ). 4 is obtained from the mix ratio (1:4).

**Examples:**

1. If the mortar mix is 1:4 (1 part cement, 4 parts sand), then the percentage increment =  $100/4 = 25\%$ .
2. If the mortar mix is 1:3, then the percentage increment =  $100/3 = 33\%$
3. If the mortar mix is 1:6, then the percentage increment =  $100/6 = 16.6\%$

**Table 4.1:** Quantities of materials required to make 1m<sup>3</sup> of various mortar mixes

Sr.no.	Mortar mix	Sand in m <sup>3</sup>	Cement in m <sup>3</sup>
1	1:4	1:0	0.25
2	1:3	1:0	0.33
3	1:2	1:0	0.55
4	1:1 ½	1:0	0.67
5	1:1	1:0	1.00

Let us take the 1:3 mix and see how cement is 0.33% and sand is 1.00m<sup>3</sup> in the 1m<sup>3</sup> mortar.

- Since the mix is 1:3, sand holds 3 parts of the total 1m<sup>3</sup> mortar.

- Percentage for increment =  $100/3 = 33\%$
- The exact volume we need is  $1\text{m}^3$
- The actual volume of mortar we have to prepare
  - =  $1\text{m}^3 + [1\text{m}^3 + 33/100]$
  - =  $1.33\text{ m}^3$ . then,
- Cement =  $1.33\text{ m}^3 \times \frac{1}{4} = 0.33\text{m}^3$
- Sand =  $0.33 \times 3 = 1.0\text{m}^3$
- Therefore we have to mix together  $1.0\text{ m}^3$  sand and  $0.33\text{m}^3$  cement to produce  $1.33\text{ m}^3$  of mortar.
- Out of  $1.33\text{ m}^3$ ,  $1\text{m}^3$  will be used while  $0.33\text{ m}^3$  will be wasted as mentioned earlier.

### Batching

By the term “batching” we mean that we measure the proportion of the various ingredients of the mix. We already know that the ingredients for a mortar should be mixed in certain proportions.

To help us to measure the correct amounts we can make box with the appropriate sizes. This method is known as “batching by volume” and the box is called a “measuring box”.

A measuring box has no bottom, it is placed on the mixing plat-form, filled with cement or sand or gravel and lifted up so that the material remains on the plat-form.

To determine the size of a box required, first of all, we have to know the volume of cement to be added in the mix.

For example, let one bag of cement is required in a 1:6 mortar mix. One bag of cement is equal to 0.035m<sup>3</sup> by volume (or 50kg by weight). Therefore, we have to produce a box whose internal volume is 0.025m<sup>3</sup>. For this a box whose internal dimension is 50cm x 40cm x 20cm (50cm x 40cm x 20cm = 0.035m<sup>3</sup>).

After you have prepared the box, the next step is to measure sand and cement according to the mix ratio given. The mix ratio in the example is 1:6. Therefore;

- First fill sand into the box and then lift it up. The sand will remain in the plat-form. Repeat this six times (6 box sand)
- Next, put the box over the sand and once fill it with cement and then lift it up, the cement will be over the sand (1 box cement)
- Total volume of mortar = volume of cement + volume of sand  
= 0.035 m<sup>3</sup> + [6 x 0.035 m<sup>3</sup>]  
= 0.035 m<sup>3</sup> + 0.21 m<sup>3</sup>  
= 0.245 m<sup>3</sup>  
= 0.25 m<sup>3</sup>

**Examples:**

1. In brick masonry work, out of the total volume of mortar that should be prepared, 3 m<sup>3</sup> of it will be utilized. The remaining volume will be lost as wastage during the working process. The mortar mix is 1:4. Therefore, determine the size (internal dimensions) of the box required to measure the volumes of cement and sand in the mix.

- First calculate the total volume of mortar to be prepared

$$\begin{aligned}\text{Total volume of mortar} &= 3 \text{ m}^3 + [3 \text{ m}^3 \times 25\%] \\ &= 3 \text{ m}^3 + 0.75 \text{ m}^3 \\ &= 3.75 \text{ m}^3\end{aligned}$$

- Calculate the volumes of cement and sand of the total volume of mortar. Then;

$$\text{Cement} = 1/5 \times 3.75 \text{ m}^3 = 0.75 \text{ m}^3$$

$$\text{Sand} = 0.75 \text{ m}^3 \times 4 = 3.0 \text{ m}^3$$

- Now, since the volume of cement is found, determine the size

$$\text{Volume of cement} = 0.75 \text{ m}^3$$

$$\text{Let length of the box} = 1.5 \text{ m}$$

$$\text{Let the width of the box} = 1.0 \text{ m}$$

$$\text{Volume} = L \times W \times \text{height}$$

$$0.75 \text{ m}^3 = 1.5 \times 1.0 \times H \text{ (height)}$$

$$0.75 \text{ m}^3 = 1.5 \times H$$

$$H = 0.75 \text{ m}^3 / 1.5$$

$$H = 0.5 \text{ m}$$

$$H = 50 \text{ cm}$$

Therefore, the size of the box that you need to prepare is 1.5 m x 1.0 x 0.5 m. This size of box is too large and becomes heavy to lift it up when filled with cement or sand. Therefore, you can reduce its size by half which means length will be 75 cm, width becomes 50 cm and height becomes 25 cm. now the measurement becomes as follows:

- Cement = 2 [0.75 x 0.5 x 0.25]
- Sand = 8 [0.75 x 0.5 x 0.25]

2. A wall is to be plastered with a cement mortar composed of 1:2 mix ratio. Exactly 1 m<sup>3</sup> of mortar was found to be sufficient for this purpose. So, demonstrate how you can determine the size of the measuring box.

**Solution:**

- First determine the total volume of mortar to be prepared  
 Total volume of mortar =  $1\text{ m}^3 + [1\text{ m}^3 \times 50\% \text{ (percent increment)}]$   
 $= 1\text{ m}^3 + 0.5\text{ m}^3$   
 $= 1.5\text{ m}^3$
- Find the volume of cement and sand out of the total mix (i.e. out of 1.5 m<sup>3</sup>), hence;  
 Cement =  $\frac{1}{3} \times 1.5\text{ m}^3 = 0.5\text{ m}^3$   
 Sand =  $2 \times 0.5\text{ m}^3$   
 Total mortar =  $1.0\text{ m}^3 + 0.5\text{ m}^3$

- Now determine the size of the measuring box you will use. Since the volume of cement is known.

Let length (l) of the box = 80 cm

Let width (w) of the box = 80 cm

Let height (h) of the box = h cm. Then,

Volume = l x w x h

$$0.5 \text{ m}^3 = 0.8 \times 0.8 \times h$$

$$h = 0.5 / 0.64$$

$$h = 0.78\text{m}$$

$$h = 78 \text{ cm}$$

- Therefore the size of the box is [80 x 80 x 78]cm

If you are fear of difficulty in lifting this size of box when it is filled with either cement or sand, you can reduce by half size, i.e., [40 x 40 x 39]. If you do so, you have to measure cement twice and sand four times.

Now the measuring procedure is as follows;

$$\text{Cement} = 1[0.8 \times 0.8 \times 0.78]\text{m} \text{ OR } 2[0.4 \times 0.4 \times 0.39] \text{ m}$$

$$\text{Sand} = 2[0.8 \times 0.8 \times 0.78]\text{m} \text{ OR } 4[0.4 \times 0.4 \times 0.39]\text{m}$$

**Table 4.2:** Internal dimensions of measuring boxes up to a capacity of 1m<sup>3</sup>

Ser	Size of box in cm	Capacity (m <sup>3</sup> )
1	40 x 40 x 31	0.05
2	50 x 50 x 40	0.01
3	60 x 60 x 55	0.02
4	80 x 80 x 47	0.03
5	80 x 80 x 62	0.04
6	80 x 80 x 78	0.05
7	100 x 100 x 100	1.00

**Mixing mortar**

Mixing is one of the most important stages in the process of making mortar because the workability and strength of mortar depend so much on the way it is mixed and on the amount of water added to the mix.

The procedure for mixing the ingredients of mortar (or concrete);

1. **Three times dry:** The sand and cement is measured on one end of the mixing plat form. With two men facing each other across the pile and working their shovels together, turn the whole heap over once to form a pile at the other

end of the plat form. This turning must be repeated twice and result is a so-called “dry mix”

2. **Three times wet:** from the heap of dry mix into a crater or pool, with the sides drawn out towards the edges of the mixing plat form. There should be no mixture left in the center of pool.

Now gently pour about  $\frac{3}{4}$  of the total required water into the crater. Turn the shovel over and with the edge scraping along the plat form, push some of the dry mix into the pool in such a way that it spreads out, without separating the sand and cement. Handle the shovel carefully so that no water can escape by breaking through the ring.

When all of the dry mix has been heaped up in the center of the plat form, it should have taken up all the free water and have a rather stiff consistency (earth-moist).

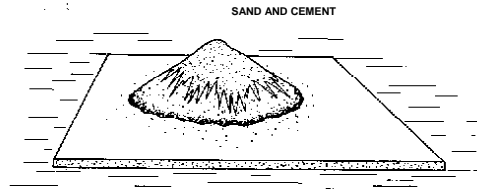

Fig 4.1: sand and cement (Source: Rural Building Course, Volume 1 – 2, 1995)



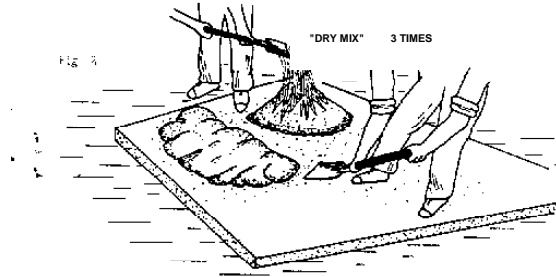

Fig 4.2: dry mix Source (Source: Rural Building Course, Volume 1 – 2, 1995)

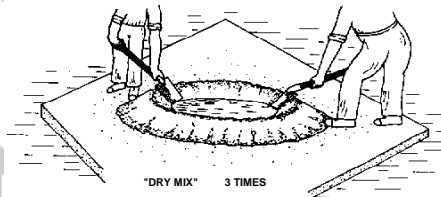

Fig 4.3: wet mix Source (Source: Rural Building Course, Volume 1 – 2, 1995)

## II. Mud mortar

Mud mortar is earth and sand mixed in proportion of 1:2 or even earth only if sieved. It is commonly used in Ethiopia particularly for plastering wooden houses and also for bedding and plastering stone masonry buildings. However, it is not commonly used in making such dried bricks (blocks). Had mud mortar been used to make mud bricks (i.e., sun dried bricks), the amount of trees being cut in Ethiopia each year would have been saved greatly. To this effect deforestation,

soil erosion and draught will be minimized or won't occur in the country. And results in less deforestation rate and soil erosion as well as no more draught would occur in the country. Therefore, it is high time to teach its advantages and demonstrate its application to communities of our country that is now widely engaged in cutting natural forest for the purpose of construction works.

### **Advantages of mud mortar**

Mud mortar may have environmental and economical advantages. The environmental advantage is that mud bricks can be made from mud that can substitute the application of timber and there by minimizing deforestation rate. The economical advantages are of many types of which some are:

- It is easily obtainable
- It can be prepared easily
- It is cheap and less laborious
- It can be used for plastering and bedding walls of stones and bricks, etc.

### **Preparation of stabilized mud mortar**

- Soil free from organic matter is collected from a suitable place. The upper 2.5 to 5 cm layer of soil should be removed as it contains high organic matter

- When two types of soils, or soil and sand is to be mixed, should be stacked one over the other and then mixed thoroughly by turning three times. (chopped straw and cow dung can be added if the mud is for plastering. However, if it is to be used for brick making no organic matters are added.
- Then water is added. The mass is left to soak for 2-14 days. After this it is thoroughly mixed, more water being added as necessary.
- After the soil has been mixed in sufficient quantity, it may be used for brick making or plastering.

**Stabilized soil bricks (sun- dried mud bricks)**

- Stabilized soil bricks may be made by hand molding
- The inside dimension of the hand molding is the same as the size of modern brick or block.
- The mold is simply made of wooden planks shaped to a box form having size as mentioned above.
- The mold is sprinkled with fines and to prevent sticking of the soil in the mold
- The homogenous mix of the prepared stabilized soil is then placed and pressed in the dusted mold slightly in excess and struck with a wooden rammer or steel edge.

- The mold is then inverted and the molded brick is placed on a small wooden plank or on a well cleared and leveled ground and removed and allowed to dry.
- The mold is then inverted and the molded brick is placed on a small wooden plank or on a well cleared and leveled ground and removed and allowed to dry.
- When the molded bricks are hardened to some extent, they are stacked and cured by sprinkling with water at least a day. After complete drying and hardening the bricks are used for construction.

### **Construction of wall with stabilized soil brick**

Stabilized soil bricks are used in the construction of wall with proper bonds in the same manner as for burnt bricks. The bricks may be laid with ordinary mud mortar or preferably with mud mortar mix with cement.

If laid with ordinary mud mortar, the wall should be protected with non erodable type, water proof mud plaster on the outside, and ordinary mud plaster may be used for inside.

Bigger size of blocks if used, require less mortar and the structure becomes strong and provides added protection against water penetration. During construction, the wall should be made perfectly in plumb.

To avoid direct erosion caused by direct impact of rain, the roof eaves (roof projection) may be projected beyond the wall and the wall up to 40 cm high from the base may be painted with used oil or may be plastered with strong cement mortar.

### **Wooden building plastered with mud mortar**

Studding is used to describe the uprights which run from top beam (wall plate) to the bottom beam (sill). Studding is spaced from 0.6m to 1.0m or even more apart depending on the type and size of building. The height of the studs above the ground level is about 3-4 meters. This may decrease if the building is not living room etc. If the building is for example, the height of the studs above the ground may be 2 – 2.5 meters. Walling (i.e., horizontal walling) [*mager*] are placed on these vertical studs at interval of 1 m. the sub-walling (i.e., diagonal braces) are placed at interval of 20 cm. These sub wallings are better to be placed in diagonal position, otherwise in horizontal. The space between the horizontal and diagonal walling is then filled with splitted timber which are tied by means of grass, rope, park wicker, rattan or nailed with nails. Spaces are left for doors and windows by means of header between the studs. The position of walls is erected in the same way timber tied with nails or hoops. The foundation of wooden house should be store, 20-40 cm deep.

A wooden framed building may be covered in the outside with corrugated iron sheets and in the inside with play wood. Other wise, a wooden framed building may be plastered both in the out side and inside with mud mortar and if possible with cement mortar. To avoid cracking of walls plastered with mud mortar, straw and cow dung may be added in the mixture.

In addition to proper plastering, wooden framed buildings that are plastered with mud mortar (cement mortar), should be protected from rain by providing a generous roof 80 cm or verandah, and the base of the wall up to 40 cm above the ground painted with burnt oil or tar.

### **4.3 Concrete**

Concrete is a mixture of cement, sand and aggregates (such as gravel or crushed stone) in various proportions. It is used for pouring slabs of floor or tanks. Slabs of tanks are meant slabs that cover pits of latrine; spring, well, septic tanks, manholes, etc.

Aggregate is small pieces of stone mixed with cement and sand to form concrete. Course aggregates may be gravel, crushed stone or crushed brick. Fine aggregate is sand. Gravel is usually found along rivers and streams, small

pebbles and stones, worn fairly smooth and rounded by the action of water.

Crushed stones are large pieces of rock or stone broken down to aggregate size, by manual labor using sledge hammers.

**Sizes of aggregates:**

Aggregates should be well-graded so that air voids between pieces are minimal. 10 mm should be for roof slabs and 20 – 25 mm for unreinforced or lightly reinforced slabs.

**Water:**

The amount of water for ordinary concrete mix should be to 5 % by weight of total aggregate (course and fine) plus 30% by weight of cement.

**Volume of concrete**

The total volume of concrete mix is not less than the total volume of aggregate. Typically, air voids must first be filled by the mortar. Excess mortar is then added to the volume of the concrete.

In practice for estimating purposes, the reduction in volume (i.e., the wastage in volume) of finished concrete over the sum total volume of ingredient materials is taken as 50% to 55%.

Simply saying, you have to add 50% - 55% for wastage to the exact volume you found after you estimate the amount required.

For example, according to your estimation you have found that 100 m<sup>3</sup> of concrete is required. Then to this you have to add to it 50% - 55% for wastage. If add 52% for wastage, volume of concrete will be 152%.

**Table 4.3:** Materials required for 100m<sup>3</sup> concrete of different proportion

ser. no	Proportion	Cement (m <sup>3</sup> )	Sand (m <sup>3</sup> )	Aggregate (m <sup>3</sup> )
1	1:2:4	21.00	42.0	84
2	1:2:5	17.20	34.4	86
3	1:3:6	14.66	44.0	88
4	1:4:8	11.25	45.0	90
5	1:5:10	9.20	46.0	92

Let us take for example the 1:2:4 mix proportion and see how cement = 21 m<sup>3</sup>, sand = 42 m<sup>3</sup> and aggregate = 84 m<sup>3</sup>. The exact amount required is 100 m<sup>3</sup>. However, we have to add a certain amount of wastage to the 100 m<sup>3</sup>. So,

- Actual concrete = 100m<sup>3</sup>
- Dry concrete = 21 + 42 + 84 = 147



- The percentage added to the 100 m<sup>3</sup> is 47%
- Dry concrete =  $100 \text{ m}^3 + [100 \text{ m}^3 \times 47/100] = 147 \text{ m}^3$ ;  
which means you have to prepare 147m<sup>3</sup> concrete. Out of this 100 m<sup>3</sup> will be properly used and the rest 47m<sup>3</sup> will be wasted during working activities. Then,
- Cement =  $1/7 \times 147 \text{ m}^3 = 21\text{m}^3$
- Sand =  $2/7 \times 147 \text{ m}^3$  OR cement  $\times 2 = 42 \text{ m}^3$
- Aggregate =  $4/7 \times 147 \text{ m}^3$  OR cement  $\times 4 = 84 \text{ m}^3$

Again let us take the 1:3:6 mix proportion;

- Let exactly 100 m<sup>3</sup> of concrete is required for our purpose
- Let we assume that there will be a 50% wastage in the working activities. Therefore,
- Volume of dry concrete (i.e., before adding water) =  $100 \text{ m}^3 + [100\text{m}^3 \times 50/100] = 150 \text{ m}^3$ 
  - Cement =  $1/10 \times 150 \text{ m}^3 = 15 \text{ m}^3$
  - Sand =  $15 \text{ m}^3 \times 3 = 45 \text{ m}^3$
  - Aggregate =  $15 \text{ m}^3 \times 6 = 90 \text{ m}^3$

**Note to the teacher:** Please let the students practice estimation using other mix proportions.

You can use table 4.3 to derive the amounts of cement, sand and aggregate required of smaller volumes if the mix proportion is the same.

- For example, in your estimation you have found that  $2 \text{ m}^3$  of concrete is sufficient for your work. The mix ratio of the concrete is 1:2:4. Then determine volumes of cement, sand and aggregate.
- Solution  
In the mix ratio 1:2:4 for  $100 \text{ m}^3$ ,  
cement =  $21 \text{ m}^3$ . Then in the same mix ratio for  $2 \text{ m}^3$ ,  
cement =  $0.42 \text{ m}^3$ , i.e.,  $(21 \text{ m}^3 \times 2/100 \text{ m}^3)$   
Sand =  $0.42 \text{ m}^3 \times 2 = 0.84 \text{ m}^3$   
Aggregate =  $0.42 \text{ m}^3 \times 4 = 1.68 \text{ m}^3$ .

### **Batching**

As already explained, “batching” is measuring the proportions of ingredients of mortar or concrete by using a measuring box. The process of preparation of measuring box for concrete is also the same as is for mortar.

Let us prepare a measuring box for exactly  $1.0 \text{ m}^3$  dry concrete. A mix ratio 1:2:4 is utilized. Before determining the size of our box, we have to know first the volumes of cement, sand and aggregate in the  $1 \text{ m}^3$  dry concrete. Then;

$$\text{Cement} = 1 \text{ m}^3 \times 1/7 = 0.14 \text{ m}^3$$

$$\text{Sand} = 0.14 \text{ m}^3 \times 2 = 0.28 \text{ m}^3$$

$$\text{Aggregate} = 0.14 \text{ m}^3 \times 4 = 0.56 \text{ m}^3$$

- Now take the volume of cement as a base to determine the size of the measuring box
- Let the length (l) of the box = 60 cm, width (w) = 50 cm and height = h cm. then;

$$\text{Volume of cement} = 0.6 \times 0.5 \times h$$

$$0.14 \text{ m}^3 = 0.6 \times 0.5 \times h$$

$$h = 0.14/0.3 = 0.47 \text{ m} = 47 \text{ cm.}$$

Therefore the size (internal dimension) of the box is

$$60 \times 50 \times 47$$

### **Reinforced concrete**

Reinforced concrete is a concrete work with reinforcing steel rods or bars imbedded in it for additional strength and support. Wire screening or steel wire netting can also be used. Reinforcement of concrete is only needed for slabs which are large in area. A reinforced slab can be thinner than a non reinforced slab.

### **Types of reinforcement steel**

There are various types of reinforcement steel, depending on the function, shape and dimensions of the reinforced concrete member as well as on the required strength.

Reinforcement steel is classified according to its shape and surface texture. The most common reinforcement is single round bars which can have either as smooth or a ribbed surface.

**Ribbed bars:** round, smooth bars are available in diameters ranging from 5 mm to 28 mm. The five sizes most often in rural building are 6 mm, 8 mm, 10 mm and 12 mm.

**Ribbed bars:** the round bars with a ribbed surface are available in diameters ranging from 6 mm to 40 mm. the standard length of reinforcement bars is 9 m.

Although the strength of circular bars is sufficient for all rural building purposes, it is advisable to purchase ribbed bars if they are available in the market. This is because the ribbed bars provide a better grip to the concrete.

#### **Wire screening (steel wire netting)**

Wire screening is frequently used to reinforce small (less than 100 m<sup>2</sup>) and thin concrete slabs like man hole covers, san-plat slabs, and coping slabs.

The most common steel wire netting has square meshes measuring 5 cm by 5cm. but for such small slabs small (6

mm) size ribbed bars can also be used. The size of aggregate should be smaller than the size of the wire mesh.

### **Binding wire**

This is soft steel wire about 1 mm in diameter, used for binding (tying) reinforcement bars at the points where they cross each other. It is bought in rolls and may also be called lashing wire, annealed wire or tying wire.

### **Spacing of reinforcement bars**

Spacing of reinforcement bars means the distance (interval) between the bars when placed in position. Spacing of bars enables one to estimate the quantity (usually in meters) of bars in terms of lengths

Spacing of steel reinforcement bars depends largely on the size (diameter) of the bar, span (width) of the slab, and thickness of the slab.

The following table is useful to serve you as a reference in determining spaces and there by in estimating the length of bars you require for your work.

**Table 4.4:** Spacing of bars in slab thickness, span of slab and diameter of the bar.

Slab thickness	Steel bar diameter (mm)	Spacing of steel bar 5 cm for minimum slab span of				
		1m	1.25m	1.50m	1.75m	2m
6.5	6	15	15	12.5	7.5	5
	8	25	25	20	15	12.5
8.0	6	15	15	15	12.5	7.5
	8	25	25	25	20	15

### Reinforced concrete slabs

A slab is a structure formed to cover pits or laid over a ground to form a floor. Cover slabs are constructed to cover pits of such as pit-latrines, septic tanks, manholes, water wells, etc.

A cover slab for pit latrines can be made with timbers and other locally available materials. However, if the economy allows, a concrete slab is better and durable than timber made slabs.

The detail construction and specification of slab will be dealt later in the construction of pit-latrines and hand-dug wells. Here we will only see how to estimate concrete and reinforcement bars.

Now let us construct a cover slab for a pit latrine.

- The external dimension of the pit is 1 m by 1 m.
- The cover slab is 6 cm thick
- We will use a steel reinforcement bar of 6 mm diameter.
- The mix ratio of the concrete is 1:2:4.
- Next let us estimate the materials required for the construction of the slab. Then;

- Volume of concrete

Volume of concrete = volume of the slab

$1\text{m} \times 1\text{m} \times 0.06\text{m} = l \times w \times \text{thickness of the slab}$

$1\text{m} \times 1\text{m} \times 0.06\text{m} = 0.06\text{m}^3$  (wet volume)

add 50% of  $0.06\text{m}^3$  to get dry concrete =  $0.06 + [0.06 \times 50\%] = 0.09\text{m}^3$

- cement =  $1/7 \times 0.09 \text{ m}^3 = 0.01 \text{ m}^3$

- sand =  $0.01 \text{ m}^3 \times 2 = 0.03 \text{ m}^3$

- aggregate =  $0.01 \times 4 = 0.04 \text{ m}^3$

- length (m) of reinforcement bar:

span of the slab = 1 m, diameter of bar = 8 mm

therefore by looking at the table for spacing of bars, the centre to centre distance between the bars is 25 cm. hence,

number of main bars =  $[100 \text{ cm} / 25] + 1 = 5$

number of distribution bars =  $[100 \text{ cm} / 25] = 5$

total bars =  $5 + 5 = 10$  each 1 m long = 10 m.

## Formwork for slabs

This is the wooden structure which holds and supports the concrete pieces while they are being cast. Concrete (mortar) structures may be structured in any shape for which it is possible to build forms. Formwork means a work of preparing a mold to form the shape of your structure.

Forms for concrete (mortar) are fabricated from lumber, plywood, steel, aluminum and other materials such as bricks, or excavating on the ground according to the shape, dimension and thickness of the structure.

Here construction of wooden (lumber) forms is dealt. To form means to cast a shape of a structure rectangular, square or circular.

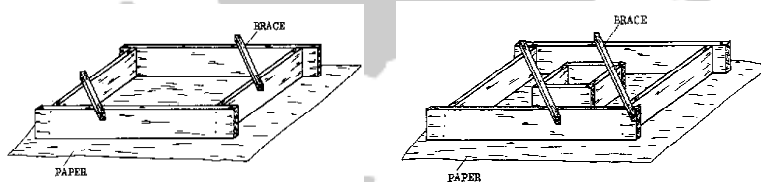

Fig 4.5 – 4.6: formwork (Source: Rural Building Course, Volume 3, 1995)

## General hints for formwork

- use good, straight – grained wood (lumber)
- Make a sketch of the formwork before you start to make it.



- Design the formwork so it can be easily removed from the piece after curing
- Use enough supports and braces to make the formwork rigid and strong.
- Be aware that the wood swells when it is in contact with the concrete.
- If the concrete will not be plastered later, plane the formwork members smooth where they are in contact with the concrete
- Do not over nail the structure, and fix the nails so that they can be taken out easily
- Oil the form lightly where it is in contact with concrete or if oil is not present, line the form with a paper or with banana leaves etc.
- Put the form on the ground in a level spot, and put paper underneath if (old cement bags)
- Remove the form work only when the concrete has hardened (cured)
- Be careful not to damage the edges and corners of the concrete piece when you remove the formwork
- Clean off the formwork with a steel brush and take out all nails when you finish.
- Now prepare a formwork as illustrated in the figures above. If a lumber is not available to make the formwork, you can make it with aligning bricks, or dig a pit on the ground 1 m x 1 m x 0.06m.--> inside dimensions

- Next make a measuring box and measure the ingredients according to the proportions given, and
- Mix them with water by turning in the same manner as explained in the mixing procedures for mortar
- Tie the bars at each point of crossing with a binding wire or string, about 8 -10 cm (20 gm) long binding wire for each tie is sufficient.
- Before placing the bars on the formwork (mold) first place at least 1.5 cm (better if 3cm) thick (height) concrete in the formwork
- This is done to prevent crossing (rusting) of the bars
- Following, place the bars over the already placed concrete layer
- Next place the hole of the mold according to your specified size. This will be treated later in the construction of latrines. Cut the bars passing through the hole.
- Later, place the remaining concrete piece by piece over the bars and spread it evenly by using a trowel. Then rammer (compact) the concrete with a strong trowel or other materials until bubbles of water are seen at the top of the concrete
- After ½ to 1 hour, remove the hole mold carefully
- Everyday for 7 days pour water on the concrete and recover to make sure it reaches full strength. This is called curing.

- It is better to cover the slab with plastic, sacks, or paper or grass while it is curing in order to prevent from cracking. You can remove.
- The formwork in the next days depending on the strength of the slab

**NB:** The bars should never touch the inner edges and corners of the formwork (mold). This is because it will removed easily. In the example so far discussed length of the bars we should cut were 1m long. However, instead of cutting 1m long, it is advisable to cut them to a length of 96 cm to 97 cm.

**Note to the teacher:** material and cost estimation should practiced by students on different projects based on given hints.

## Review Questions

1. In a brick masonry work,  $3 \text{ m}^3$  of mortar is required for bedding the bricks. The mortar mix is 1:5. Then determine:
  - a. Percentage increment for wastage
  - b. The actual volume ( $\text{m}^3$ ) of mortar required
  - c. Volume of cement ( $\text{m}^3$ )
  - d. Volume of sand ( $\text{m}^3$ )
  - e. Liters of water to make the mix
  
2. A wall of spring is to be plastered with cement mortar. A 1:8 mix ratio is used to make the mortar. The exact quantity of mortar required was estimated to be  $2.5\text{m}^3$ . therefore, determine:
  - a. Percentage increment for wastage
  - b. The actual volume of mortar required
  - c. Volumes of sand and cement
  - d. Liters of water to mix the cement and sand
  
3. A floor is to be finished (smoothed) with a layer of mortar. The mix ratio used is 1:10. It was found that  $0.5\text{m}^3$  of mortar is sufficient for the work. So, determine:
  - a. Percent increment for wastage
  - b. Volumes of cement and sand

# CHAPTER FIVE

## ESTIMATING AND COSTING

### Learning Objectives

At the end of this chapter students are expected to

- Identify approximate and actual cost estimation
- Estimate the cost of various sub-structures and super-structures
- Prepare the detail material and cost estimation for common sanitary structure.

For all engineering works it is required to know before hand the probable of construction known as the estimated cost. In preparing an estimate, the quantities of different items of work are calculated by simple measurement method and from these quantities the cost is calculated.

The subject of estimating is simple, nothing much to understand, but knowledge of drawing is essential. One who understands and can read drawing may find out the dimensions-lengths, breadths, heights, etc. From the drawing without difficulty and may calculate the quantities. The calculations mainly consist of

Length X breadth X height or  
Length X breadth X or  
Length X height

In preparing an estimate, omission of items, changes in designs, improper rates, etc. are the reasons for exceeding the estimate, though increase in the rates is one of the main reasons.

In framing a correct estimate, care should be taken to find out the dimensions of all the items correctly, and to avoid omissions of any kind of work or part thereof. The rate of each item should also be reasonable and workable. The rates in the estimate provide for the complete work, which consist of the cost of materials, cost of transport, cost of labour, cost of scaffolding, cost of tools and plants, cost of water, taxes, establishment and supervision cost, reasonable profit of contractor, etc.

The conventions and units of different items of works vary to some extent from state to state, though the units of the most of the items are same. Therefore, knowing the metric system and units is important. For example, basic SI units:

Units of length – meter (M)

Units of mass – kilogram (kg)

Units of time – second (S)

Units of electric current – Ampere (A) etc

## 5.1 Method of Estimating

I. **Estimate**:- before undertaking the construction of a project it is necessary to know its probable cost which is worked out by estimating. An estimate is a computation or calculation of the quantities required and expenditure likely to be incurred in the construction work. The primary objective of the estimate is to enable one to know beforehand, the cost of the work (building, structures, sanitary facilities, etc.). The estimate is the probable cost of a work and is determined theoretically by mathematical calculations based on the plans and drawing and current rates. Approximate estimate may be prepared by various methods but accurate estimate is prepared by detailed.

II. **Actual cost**:- The actual cost of a work is known at the completion of the work. Account of all expenditure is maintained day-to day during the execution of work in the account section and at the end of the completion of the work when the account is completed, the actual cost is known.

**N.B:** the actual cost should not differ much from the estimated cost worked out at the beginning.

III. **Detailed estimate**: preparation of detailed estimate consists of working out the quantities of different items of work

and then working out the cost i.e. the estimate is prepared in two stages:

1. Details of measurements and calculation of quantities:  
The whole work is divided into different items of work as earth work, concrete, brickwork, etc. And the items are classified and grouped under different sub-heads, and details of measurement of each item of work are taken out and quantities under each item are computed in prescribed form- details of measurement form.

**Table 5.1** Details of measurement form

Item no.	Description or particulars	no	Length	breadth	Height or depth	Content or quantity	Total content or quantity

2. Abstract of Estimated cost:

The cost under item of work is calculated from the quantities already computed at workable rate, and the total cost is worked out in a prescribed form:

**Table 5.2** Abstract of estimate form.

Item no.	Description or particulars	quantity	Unit	Rate	Amount



- A of 3 to 5 is added for contingencies, to allow for petty contingent expenditures, unforeseen expenditures, changes in design, changes in rates, etc. which may occur during the execution of work.
- A percentage of 1 ½ to 2 is also added to meet the expenditure sub-head wise but for beginners it is convenient to make up the items in the same order, as far as possible, as they would be executed or constructed. If the principle of following the order of construction from foundation to upward direction is followed there is little chance of omission of items.

## **5.2. Work Specification (main items of work)**

Specification describes the nature and the class of the work, materials to be used in the work, workmanship, etc., and is very important for the execution of the work. The cost of a work depends much on the specifications. Specifications should be clear, and there should not be any ambiguity anywhere. From the study of the specifications one can easily understand the nature of the work and what the work shall be. During writing specifications attempts should be made to express all the requirements of the work clearly and in a concise form avoiding repetition.

Specifications depend on the nature of the work, the purpose for which the work is required, strength of the materials, availability of materials, quality of materials, etc.

For general idea, the general specifications of common sanitary structures are given below.

1. **Earthwork:** - earth work in excavation and earth work in filling are usually taken out separately under different items, and quantities are calculated in cubic meter.
2. **Concrete in foundation:** - the concrete is taken out in cubic meter by length X breadth X thickness. The length and breadth of foundation concrete are usually the same as for excavation, only the depth or thickness differs. Foundation concrete consists of lime concrete or weak cement concrete. The proportion of cement concrete in foundation may be 1:4:8 or 1:5:10.
3. **Soiling:** - when the soil is soft or bad, one layer of dry brick or stone soiling is applied below the foundation concrete. The soiling layer is computed in square meter (length X breadth) specifying the thickness.

4. **Damp proof course:-** D.P.C. Usually of 2.5 cm thick rich cement concrete 1:1 ½:3 or 2 cm thick rich cement mortar 1:2 mixed with standard water proofing materials, is provided at the plinth level to full width of plinth wall, and the quantities are computed in square meter (length x breadth).

5. **Masonry:-** masonry is computed in cubic meter (length x breadth x height). Foundation and plinth masonry is taken under one item, and masonry in superstructure is taken under a separate item. In storey building the masonry in each storey as ground floor above plinth level, first floor, etc. is computed separately. In taking out quantities the walls are measured as solid and then deductions are made for openings as doors, windows, etc. and such other options as necessary.

**N.B.** No deduction is made for the following:

1. Opening each upto 0.1 square meter
2. Ends of beams, posts, rafters, purlins, etc, upto 0.05 gram in section
3. Bed plate, wall plate and the like upto 10 cm depth
4. Bearings of floor and roof slabs are not deducted from all masonry

## **6. Plastering and pointing**

- plastering usually 12 mm (1/2 ") thick is calculated in square meter. For walls the measurements are taken for the whole face of the wall for both sides as solid.
- Pointing in walls is calculated in square meter for whole surface

## **5.3. Units of Measurement in Metric System**

The principle for dimensions and measurements is to use millimeters (mm) for minute dimensions, centimeter (cm) for small dimensions and meter (m) for big dimensions. Distances are measured in kilometers (km).

The dimensional units for main item of materials and works for general construction work as used in metric system are as follows:

**Table 5.3.** Units of measurement in metric system

<b>Particulars of materials and works</b>	<b>Dimensions metric system</b>
1. bricks, stones, blocks, etc.	All dimensions cm
2. corrugated iron sheets	Length and breadth in cm or m,
3. Doors, windows, etc...	thickness in mm
4. timber	Height and breadth in cm or m
5. masonry (brick work, stone work, etc...	Length in m and cross-sectional dimensions in cm, or m
6. cement concrete, lime concrete, Floor	Length and height in cm, thickness or breadth in cm
7. Aggregates, basalt, sand etc	Length and breadth in m, thickness in cm
8. mild steel bars	Size in mm
	Length in m, diameter in mm

#### 5.4. Estimation of Construction Cost

It is clear that the cost of materials, equipment and labor differs from place to place and time to time. It is hoped that this topic will give you a general over view of estimating the construction cost of some sanitation projects such as VIPL (ventilated improved pit latrine) of different seat, and

traditional pit latrine which are expected to give service for individual families and for institutions.

### I. Cost and material estimation of Single unit VIPL

Dimensions of the pit:

Length = 0.90m

Width = 1.20m

Depth = 3m

#### 1. cost of excavation

Volume of excavation =  $L \times w \times d$

$1\text{m}^3$  of excavation costs birr 18 (assume)

$3.24\text{ m}^3$  of excavation costs birr?

Birr 58.32

#### 2. slab construction

Dimensions (L X W X H = 1.9m x 2.2m x 0.1m)

Volume of slab =  $0.418\text{ m}^3$

Add 25 % of the total on the total for loss during construction

→  $25\% \times 0.418\text{ m}^3 + 0.418\text{ m}^3 = \underline{0.52225\text{ m}^3}$

Amount of cement, sand and gravel in proportion 1:2:3

Amount of cement =  $1/6 \times 0.5225 = 0.087\text{ m}^3$

Amount of sand =  $2/6 \times 0.5225 = 0.1741\text{ m}^3$

Amount of gravel =  $3/6 \times 0.5225 = 0.26\text{ m}^3$

3. Iron bars (8 mm diameter) and thin wire

**Iron bars:**

- dimension (L = 1.90m, W = 2.2 m), interval = 10 cm
- iron bars in width =  $(1.9 / 0.1) + 1 = 20$  pieces each  
2.2 m long = 44m
- iron bar in length =  $2.2 / 0.1 + 1 = 23$  pieces each 1.9  
m long. = 43.7 m = 44 m
- total  $(44 + 44)m = 88m$
- market standard ,1 piece has 12 m length  
→  $88m / 12m = 7$  pieces of 12 m long.

**Thin wire for tying:**

- Total number of connections = (pieces in length wire x  
pieces in width wire) =  $20 \times 23 = 460$
- 1 cross needs = 7 gm
- 460 crosses need =  $460 \times 7 \text{ gm} = 3220 \text{ gm} = 3.220$   
Kgs of thin wire

**N.B.** If you want the slab to be more clean and smooth,  
plaster it by taking plastering thickness of 0.03m and  
proportion of (1:3).

4. super structure

- made of a solid block (brick)
- dimensions

a solid block = 0.4m x 0.15m x 0.15m

2 side walls = 1.2m x 0.15m x 2m

1 back wall = 0.90m x 0.15m x 2m

1 front wall = 0.90m x 0.15m x 2.4m

1 door = 2m x 0.80m x 0.05m

2 side screens = 0.60m x 0.30m x 0.03m

- number of blocks = [volume of wall/volume of a block – volume of open spaces/volume of a block]

a) Volume of wall = {2 [1.2m x 0.15m x 2m] + [0.9m x 0.15m x 2m] x [0.9 x 0.15m x 2.4m]} = 1.364 m<sup>3</sup>

b) Volume of a block = 0.40m x 0.15m x 0.15 = 0.009m<sup>3</sup>

c) Volume of door and screens = [2m x 0.8m x 0.05m] + 2[0.06m x 0.30m x 0.3m] = 0.09m<sup>3</sup> → number of blocks = 1.364m<sup>3</sup> – 0.09m<sup>3</sup>/0.009m<sup>3</sup> = 141 blocks.

- Add 3.5% of the total on the total for loss during construction

→ 3.5% x 141 + 141 = 148 blocks.

- Mortar for jointing the blocks

From total wall volume, i.e., 1.36m<sup>3</sup> 25% is mortar.

25% x 1.36m<sup>3</sup> + 1.36m<sup>3</sup> = 1.7 m<sup>3</sup>

cement = ¼ x 1.7 = 0.425m<sup>3</sup>

sand = ¾ x 1.7 = 1.275m<sup>3</sup>



5. Roofing

a) CIS

b) Nails

C.I.S for gable roof = (length of eaves/width of a C.I.S x  
No of sheets on the slop)<sup>2</sup>

C.I.S for lean – to – roof = [length of caves/width of a CIS  
x No sheets on the slop]

Here the roof that we consider is lean – to – roof, i.e., number  
of C.I.S= 2.90m/0.70m = 4

- 1 C.I.S needs 10 nails #7

→ 4 x 10 = 40 nails #7

- 1 nail of no. 7 weighs 0.07 kg

→ 40 nails weigh 40 x 0.07 (2.8 kg)

- in estimating the construction cost of the above project  
you should consider the cost of

c) PVC pipe (1 #) for vent

d) door (1 #) plain sheet (2m x 0.80m x 0.05)

e) screen (0.6m x 0.3m x 0.03m)

f) wood

purlin – 3 in #

rafter – 3 in #

g) labor spent

## II. Cost and material estimation of double unit VIPL

- Dimensions of the pit

$$L = 2\text{m}$$

$$W = 1.5\text{m}$$

$$\text{Depth} = 3\text{m}$$

1. cost to excavation

$$\text{Volume of excavation} = L \times W \times D = 2\text{m} \times 1.5\text{m} \times 3\text{m} = 9\text{m}^3$$

**N.B.**  $1\text{m}^3$  of excavation costs 18 birr (assumption)

2. slab construction

- Dimension

$$L = 3\text{m}$$

$$\text{Width} = 2.50\text{m}$$

$$\text{Height} = 0.07\text{m}$$

$$\text{Volume of slab} = L \times W \times H = 3\text{m} \times 2.5\text{m} \times 0.07\text{m} = 0.525\text{m}^3$$

Add 25% of the total on the total for loss during construction

$$\rightarrow 25\% \times 0.525\text{m}^3 + 0.525\text{m}^3 = 0.656\text{m}^3$$

- Proportion of concrete work = 1:2:3 (cement: sand: gravel).
- Amount of cement =  $1/6 \times 0.656\text{m}^3 = 0.109\text{m}^3 = 4$  bags of cement

**NB.** 1 bag = 0.03 m<sup>3</sup>

Amount of sand =  $2/6 \times 0.656\text{m}^3 = 0.208\text{m}^3$  of sand.

Amount of gravel =  $3/6 \times 0.656\text{m}^3 = 0.325\text{m}^3$  of gravel.

3. Iron bars and thin wires (8 mm diameter)

- Dimension

L = 3m

W = 2.5m

Intervals = 0.1m

- Iron bars in length wire =  $3\text{m}/0.1\text{m} + 1 = 31$  pieces  
each 2.5m long.

- Iron bars in width wire =  $2.5\text{m}/0.1\text{m} + 1 = 26$  pieces  
each 3m long = 78m long

- Total iron bars =  $77.5\text{m} + 78\text{m} = 155.5\text{m}$  long

**NB** market standard length of 1 piece = 12m

→  $155.5/12 = 13$  pieces each 12m long.

- Thin wire; pieces in length wise x pieces in width wise  
=  $31 \times 26 = 806$  crosses

**NB** one cross needs 7gm or 20 cm

$806 \times 7 \text{ gm} = 5642 \text{ gm}$  or 5.642 kg

- If you want to plaster, consider the thickness as  
0.03m.

## 4. super structure

## - consider

1. size of block =  $[0.4 \times 0.15 \times 0.15]\text{m}$
2. size of two gable walls =  $[1.5 \times 0.15 \times 2.5]\text{m}$
3. size of back wall =  $[2 \times 0.15 \times 2.3]\text{m}$
4. size of front wall =  $[2 \times 0.15 \times 2.4]\text{m}$
5. size of two doors =  $[2 \times 0.8 \times 0.05]\text{m}$
6. size of screens =  $[0.6 \times 0.3 \times 0.03]\text{m}$

## - # of blocks = volume of wall/volume of a block – volume of open spaces/volume of a block

a. volume of wall =  $2 [1.5 \times 0.15 \times 2.3] + [2 \times 0.15 \times 2.3] + [2 \times 0.15 \times 2.4] = 2.44 \text{ m}^3$

b. volume of a block =  $0.4 \times 0.15 \times 0.15 = 0.009 \text{ m}^3$

c. Volume of open spaces (doors and screens) =  $2[2 \times 0.8 \times 0.05] + 4[0.6 \times 0.3 \times 0.03] = 0.02 \text{ m}^3$

→ # of blocks =  $2.44 - 0.02 / 0.009 = 269$  blocks.

## - Add 3 – 5% of the total on the total for loss during construction.

$5\% \times 269 + 269 = 282$  blocks

## - mortar for jointing

from the total volume of the wall 25% is mortar

$25\% \times 2.445 = 0.6 \text{ m}^3$

## - Add 25% of the total on the total for loss

$25\% \times 0.6 \text{ m}^3 + 0.6 \text{ m}^3 = 0.75 \text{ m}^3$  of mortar with loss

- proportion – 1:3 (cement: sand)

$$\text{amount of cement} = \frac{1}{4} \times 0.75 = 0.56 \text{ m}^3$$

$$\text{amount of sand} = \frac{3}{4} \times 0.75 = 0.56 \text{ m}^3$$

5. Roofing

- C.I.S.

- Nails

$$\# \text{ C.I.S} = (\text{Length of caves}/\text{width of a C.I.S} \times \text{No. of sheets on the slope}) = 4\text{m}/0.70\text{m} = 6$$

**NB:** 1 C.I.S need = 10 nails of no. 7; 1 nail of #7 weighs = 0.007 kg

- In your cost and material estimation of the mentioned project consider the cost of:

1. PVC (1 or 2#) for vent
2. plain sheet (2m x 0.8) (2#) for doors
3. wood

purlins = 6 in number

rafter = 6 in number

4. screen (0.6 x 0.3)m

5. labor spent

### III. Cost and material estimation of Six unit VIPL

Dimensions: (L = 3, W = 2m, Depth = 3m)

1. Cost of excavation

$$\begin{aligned}\text{volume of excavation} &= L \times W \times D \\ &= 3\text{m} \times 2\text{m} \times 3\text{m} = 18 \text{ m}^3\end{aligned}$$

**N.B:** 1m<sup>3</sup> of excavation costs birr 18 (assume)

2. Slab construction

Dimensions: (L = 4m, W = 3m, H = 0.07m)

$$\begin{aligned}\text{volume of slab} &= L \times W \times H \\ &= 4\text{m} \times 3\text{m} \times 0.07\text{m} = 0.84\text{m}^3\end{aligned}$$

Add 25% of the total on the total for loss

$$25\% \times 0.84\text{m}^3 + 0.84\text{m}^3 = 1.05\text{m}^3$$

Proportion of concrete work = 1:2:3.

$$\text{Amount of cement} = 1/6 \times 1.05\text{m}^3 = 0.175\text{m}^3 = 6 \text{ bags of cement.}$$

**N.B:** 1 bag = 0.03m<sup>3</sup>

$$\text{Amount of sand} = 2/6 \times 1.05\text{m}^3 = 0.35\text{m}^3 \text{ of sand}$$

$$\text{Amount of gravel} = 3/6 \times 1.05\text{m}^3 = 0.52\text{m}^3 \text{ of gravel}$$

3. Iron bars (8mm, dia.) and thin wire

- Dimension (L = 4m, W = 3m, Interval = 0.10m)

**Iron bars**

Iron bars in length wise =  $4\text{m}/0.1 +$   
 = 41 pieces each 3m long  
 = 123m long

Iron bars in width wise =  $3/0.1\text{m} +$   
 = 31 pieces each 4m long  
 = 124 long

Total =  $123 + 124 = 247\text{m}$

**N.B:** Market standard of 1 pieces = 12m  
 $247\text{m}/12\text{m} = 21$  pieces each 12m long

**Thin wire**

$41 \times 31 = 1271$  crosses.

**N.B:** 1 cross needs = 7 gm (20 cm)  
 $1271 \times 7 \text{ gm} = 8897 \text{ gm} = 9 \text{ kg.}$

4. Superstructure

consider :

- a. block size =  $0.40\text{m} \times 0.15\text{m} \times 0.15\text{m}$
  - b. Two side walls =  $2\text{m} \times 0.15\text{m} \times 2.3\text{m}$
  - c. The three walls i.e., two front walls and one partition wall =  $3\text{m} \times 0.15\text{m} \times 2.3\text{m}$
  - d. Three plain sheets =  $2\text{m} \times 0.8\text{m} \times 0.05\text{m}$
  - e. Six screens =  $0.60\text{m} \times 0.30\text{m} \times 0.03\text{m}$
- # of blocks =  $\frac{\text{volume of wall} - \text{volume of open spaces}}{\text{volume of a block}}$

- a) volume of wall =  $2(2\text{m} \times 0.15\text{m} \times 2.3) + 3(3\text{m} \times 0.15\text{m} \times 2.4\text{m}) = 3.24 \text{ m}^3$
- b) volume of blocks =  $0.4\text{m} \times 0.15 \times 0.15 = 0.009 \text{ m}^3$
- c) volume of open spaces (doors + screens) =  $3(2\text{m} \times 0.8\text{m} \times 0.05\text{m}) + 6(0.6\text{m} \times 0.3\text{m} \times 0.03) = 0.27 \text{ m}^3$
- # of blocks =  $3.24 - 0.27/0.009 = 330$  blocks.
- Add 3-5% of the total on the total for loss during construction
  - $5\% \times 330 + 330 = 347$  blocks
- Mortar for jointing
  - From total wall volume, i.e.,  $3.24 \text{ m}^3$  25% is mortar.
  - $25\% \times 3.24\% = 0.81\text{m}^3$  of mortar
- Add 25% of the total on the total for loss
  - $25\% \times 0.81 + 0.81 = 1.025\text{m}^3$
- Proportion of mortar 1:3
  - Amount of cement =  $\frac{1}{4} \times 1.025 = 0.25\text{m}^3$ .
  - Amount of sand =  $\frac{3}{4} \times 1.025\text{m}^3 = 0.75\text{m}^3$

## 5. Roofing

### a. C.I.S

### b. Nails

- # C.I.S (length of cave/width of a C.I.S. x no. of sheets on the slope) =  $[5\text{m}/0.7]^2 = 14$  c.i.S
- Here also consider the cost of
  - 1) PVC (3 in number) for vent
  - 2) Plain sheet (6 in number) of (2m x 0.8)



- 3) Wood
  - Purlin 18 in number
  - Rafter 18 in number
- 4) Screen 6 in number of size (0.6 x 0.3)
- 5) Labor spent.

#### IV. Cost and material estimation of traditional pit latrine

Dimension of the pit (L = 1.4m, W = 0.9m, Depth = 3m)

##### 1. Cost of excavation

$$\text{volume of excavation} = L \times W \times D = 1.4 \times 0.9 \times 3 = 3.78 \text{ m}^3$$

##### 2. Slab construction

Dimensions (L=2.4m, Width=1.9m, and Thickness= 0.07m)

$$\begin{aligned} \text{volume of slab} &= L \times W \times H = 2.4\text{m} \times 1.90\text{m} \times 0.07\text{m} \\ &= 0.319\text{m}^3 \end{aligned}$$

Add 25% of the total on the total for loss during construction

$$25\% \times 0.319 \text{ m}^3 + 0.319\text{m}^3 = 0.399\text{m}^3$$

Proportion = 1:2:3.

$$\text{Amount of cement} = 1/6 \times 0.399 = 0.0665 \text{ m}^3$$

$$\text{Amount of sand} = 2/6 \times 0.399 = 0.133\text{m}^3$$

$$\text{Amount of gravel} = 3/6 \times 0.399 = 0.1995\text{m}^3$$

3. Iron bars of (8 mm, dia.) and thin wire

Dimension (L = 2.4m, W = 1.9m, and interval = 0.1m)

iron bars in length wire =  $2.4\text{m}/0.1 + 1$   
= 25 pieces each 1.9m long  
= 47.5 long

iron bars in width wire =  $1.9\text{m}/0.1\text{m} + 1$   
= 20 pieces each 2.4m long  
= 48m.

total number of iron bars =  $47.5\text{m} + 48\text{m}$   
= 95.5m long

thin wire =  $25 \times 20 = 500$  crosses

4. Superstructure

For front walls = 2 C.I.S

For back wall = 2 C.I.S.

For two side walls = 2 C.I.S

Total number 6 C.I.S for casing /walling/ system

5. Roofing

a) C . I . S

b) Nails

number of C.I.S = (Length of cave/width of a C.I.S X

number of sheets on the slop) $2 = 3.4\text{m}/0.70 = 6$  C.I.S

Total C.I.sheets required for casing and roofing =  $6 + 5$

= 11 sheets.

Consider also the cost of 1. Rafter 3 in number

2. Purlin 3 in number 3. Labor cost

## 5.5 Summary

**Table 5.4** Quantitative descriptions of materials and labor spent for the mentioned projects

Sr.	Type	Materials											Remark
		Cement bags	Sand (m <sup>3</sup> )	Gravel (m <sup>3</sup> )	I.bar piece	Thin wire (kg)	Block (no.)	C.I.S. (no.)	Nail (kg)	Excav. (no.)	Wood piece	Labor (day)	
1	Single seat VIPL	7	0.5	0.26	7	3.22	148	4	0.28	3.24	6	9	
2	Double seat VIPL	10	0.87	0.312	13	5.46	282	6	0.42	9	12	13	
3	Six seat	15	1.1	0.52	21	9	347	14	0.98	18	18	15	
4	Traditional pit latrine	2	0.133	0.199	8	3.5	-	11	0.77	3.18	18	6	

**Table 5.5** Unit price of materials and labor

Material description	Cement	Sand	Gravel	I.B	Thin wire	Block	C.I.S	Nail	Exca.	Wood	labor	Remark
Unit cost in birr	34	60	70	40	66	4	40	10	18	5	29	

**Table 5.6** Total cost of each system with contingency

Type	Single seat VIPL	Double seat VIPL	Six seat VIPL	Traditional pit latrine
Total cost	\$2070.77	\$3592.16	\$5332.58	\$1661.1

**Table 5.7** Summary price

Sr.	Item description	Unit	Quantity	Unit price	Total price	Remark
1	Cement					
2	Sand					
3	Gravel					
4	Block					
5	I.B.					
6	Thin wire					
7	C.I.S					
8	Nails					
9	Plane sheets					
10	Screen					
11	Wood -rafter -purlins					
12	labor spent					

**Note to the teacher:** material and cost estimation should be provided to students on different projects (incinerator, spring protection box, stoves, etc) based on given hints.

## Review Questions

1. What do you know about actual and estimated cost? Discuss their relationship and differences by giving examples.
  2. What are the main items of work that should be considered in material and cost estimation
  3. How do you prepare the summary quantitative description of material and labor spent for the project?
  4. Estimate the material and cost of a spring protection box.
- Note:** dimensions of the box = 2 x 1 x 0.5 for other units and figures try to assume the convenient one.

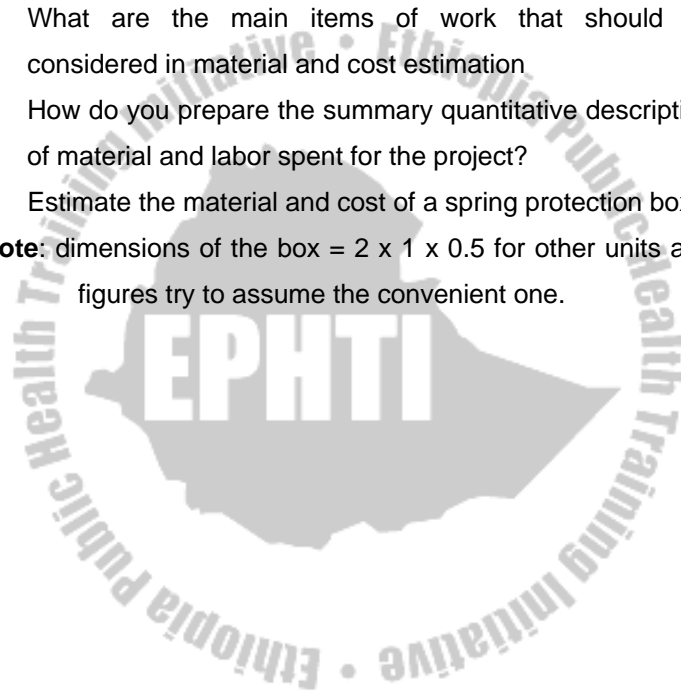

# CHAPTER SIX

## ROOF IN GENERAL

### Learning Objectives

At the end of this chapter, students will be able to understand different types of roofs and apply them in rural settings using locally available materials.

The roof is a very important part of the building structure. It performs several functions. It gives shelter to people, provides shade, isolates the building from the cold and heat, keeps out dust and dirt, protects the interior of the building, and sheds rainwater.

### 6.1 Roof Types

There are many different types of roofs. We will deal only with the following four types:

Lean – to roof (fig 6.1)

Pent roof (fig. 6.2)

Gable roof (fig. 6.3)

Hipped roof (fig. 6.4)

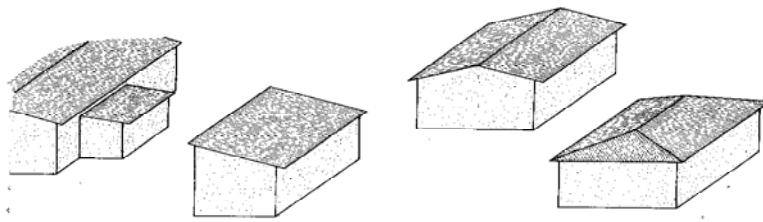

Fig 6.1 – 6.4 roof types (lean-to, pent, Gable and Hipped roof)  
 (Source: Rural Building Course, Volume 1 – 2, 1995)

## 6.2 Size of the Roof

The cost of roofing sheets will be an important part of the cost of the whole building. Therefore it is the size of the roofing sheets, which will determine the size and especially the width of the whole building.

For this reason we make an outline design of the roof before we determine the other measurement of the building. we cannot design the building first and later put a roof on it. This outline design tells us the width that our building should have so that we can fit a roof on it without unnecessary and wasteful cutting and trimming of sheets.

To make the outline design of the roof, we need to know:

- The pitch of the roof
- The effective length of the sheets
- The distance of the roof will project past outside walls of the building.



## 1. Roof pitch

The angle of the slope of the roof is called the pitch. If corrugated sheet materials are used, the pitch angles should be between 15 and 20 degree (fig 6.5).

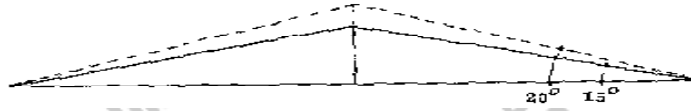

Fig 6.5: roof pitch

## 2. Effective length of the sheets

The effective length of roofing sheets is the length of the sheet (x) minus the over lap(y) between the sheets (fig. 6.6).

The minimum overlap in the length for corrugated sheeting materials is 15cm. Here you need to know the most common length for roofing sheets in your locality. For our explanation a length for roofing sheets is 2.44 m.

In order to use the sheets as economically as possible, we use 1, 1<sup>1/2</sup>, 2, 2<sup>1/2</sup>, or 3 corrugations (and so on) sheets to cover the distance from the highest point of the roof to the lower edge. Thus the effective length will be:

- For 1 sheet ..... ..2.44m
- For 1 1/2 sheets ....2.44m +122m ....15cm =3.51m

- For 2 sheets ..... $2.44\text{m}+2.44\text{m}.....15\text{m} = 4.73$
- For 3 sheets ..... $(2.44\times 3)-(15\text{cm}\times 2) = 8.02\text{m}$

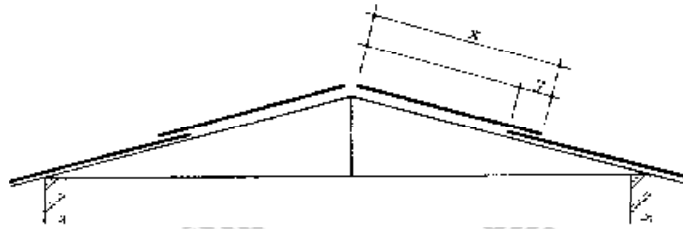

Fig 6.6: Effective length of the sheets

### Technical terms

- **TIE BEAM:** This is the horizontal member of the structure (truss) which ties together the ends (feet) of the rafters (fig. 6.7 next page)
- **RAFTERS:** These are the sloping members which give support to the purling (fig. 6.7 next page).
- **BRACES:** These are the member which strengthen the construction
- **ROOF TRUSS:** This is the structure made up of the rafters, i.e., beam and braces, which form the main load-carrying unit in some kinds of roof.
- **RURLINS:** These members lie across the rafters and support the roofing sheets
- **RIDGE:** This is the highest point of a roof construction
- **RISE OF THE TRUSS:** This is the vertical height of the truss (fig. 6.7 next page), measured between the highest

point of the truss and the tie beam. It is from  $\frac{1}{4}$  to  $\frac{1}{10}$  of the truss.

- SPAN OF THE TRUSS: This is the clear horizontal distance between the internal faces of the rafters (b) at the point where they meet the tie beam.
- SPAN OF THE BUILDING: The building span is the clear horizontal distance between the inside faces of the walls which support the roof [c]
- OVERHANG: When the tie beam, projects beyond the supporting wall, the projecting part is called over hang (d). The over hang is measured to the wall.
- EAVE: This is the lowest part of the overhang or over hanging eave (Point x)

The application of rise of the Truss, SPAN of the TRUSS, SPAN OF THE BUILDING, OVER HANGING EAVE and TIE BEAM will be dealt in the topics of determining the length of one rafter, number of covering sheets required to cover a roof and to find out the area of a given roof.

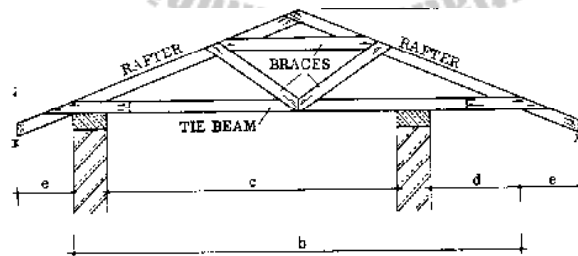

Fig 6.7: technical terms (Source: Rural Building Course, Volume 1 – 2, 1995)

## 6.3 Construction Details

### 1. Lean-to roof

A lean-to roof is a sloping roof attached to the wall of another building. It is “leaning” against the building. It is usually used for small store or smaller building (such as kitchen, toilets, and latrine), which is attached to an existing building. The main members are: (fig 5.8)

- The wall plate 5x10 to 15cm (This the tie beam)
- The rafters 5x7.5 to 10cm
- The purlins 5x7.5 cm
- The fascia board 2.5x 20 to 30 cm
- The sheet material

The above measurements can be used as guide in selecting timbers for this kind of work. Round timbers (e.g. *Bahrizat*) of the same diameters can be used if lumber is not available and cost.

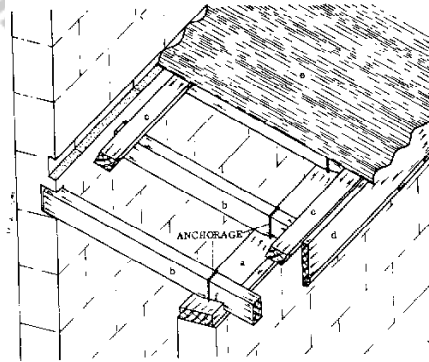

Fig 6.8: lean-to roof (Source: Rural Building Course, Volume 1 – 2, 1995)

## 2. Pent roofs

A pent roof is a roof which slopes to one side (it is also called mono-pitch roof). It differs from a lean-to roof, in that, it is not attached to the wall of another building but is supported by its own walls.

There are two types of pent roof: (1) the ordinary pent roof (2) the enclosed or parapetted pent roof.

**1. Ordinary pent roof:** In this roof, the rafters and purlins project beyond the outside walls. One wall is higher than the other wall (usually the front wall is higher than the back wall so that rain water drops in the back side of the building).

The pitch of this roof will usually be about 15-degrees. This means that the front wall is about 15cm higher than the back wall. The main members are (fig. 6.9)

- The wall plate (a) 5x10 to 15cm
- The rafters (b) 5x15cm
- The purlins (c) 5x7.5 cm
- The fascica (d) 2.5 x 20 to 30cm
- The sheet materials (e)

The above timber measurements can be used as a guide in selecting the timbers for an ordinary event roof; that is a pent roof with a span of less than 3.5m. (Span means the inside width of the building).

The distance between rafters should be 1 to 2 m, and the distance between the purlins depends on the size of the sheet materials.

- The rafters should always be with a bird's mouth so that they rest securely on the wall plate.
- Wall plates, rafters, and purlins should be well anchored.

The pent roof is often used because it is cheaper to construct than other roofs, since only rafters and purlins are used, and no tie beam, braces etc, are needed.

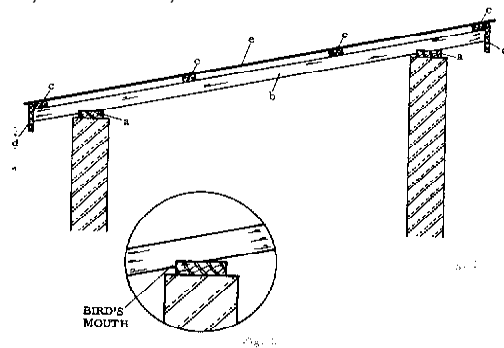

Fig 6.9: ordinary pent roof (Source: Rural Building Course, Volume 1 – 2, 1995)

**2. Enclosed vent roof:** In this roof, the higher wall and the two sloping walls enclosed and protect three sides of the roof. The parts of the parapets. Project above roof level are called parapets. Parapets help to reduce suction on the roof and to keep the sheets in place. The pitch of this roof will be about 15 degree (fig. 6.10). The parts of the roof are:

- The wall plate (a)
- The rafters (b) 5x7.5 cm

- The beam[c] 5x7.5cm
- The braces (d) 2.5x7.5cm
- The purlins (e) 5x7.5cm
- The fascia (f) 2.5x20 to 30cm
- The sheet material (g)
- The parapet (h)

The measurements above can be used as a guide for constructing this kind of roof. The distance between the rafters should be 1 to 2m, and the distance between the purlins will depend on the size of sheet material.

### 3. Gable roof

This is a roof, which slopes down on the two sides of the ridge and has a gable on one or two end walls. The gable is the triangular shaped part of the end wall where it comes up to the sloping edges of the roof.

The advantage of gable roof over pent roof is that it can be constructed to permit cross ventilation. It can be used for large or small spans.

The main parts and members of the gable roof are (fig. 6.11)

- The wall plate (a)
- The rafters (b) 5x7.5cm
- The tie beam [c] 5x7.5cm
- The braces (d) 2.5x7.5cm
- The purlins (e) 5 x 7.5cm

- The fascia (g) 2.5x20 to 30 cm
- The sheet material (g)

The above measurements should be used as a guide when you make this type of roof. The distance between the trusses will be about 2m. The last truss should be close to the wall. The gable ends can be constructed so that the purlins project beyond the gable and the fascia boards are nailed on to them.

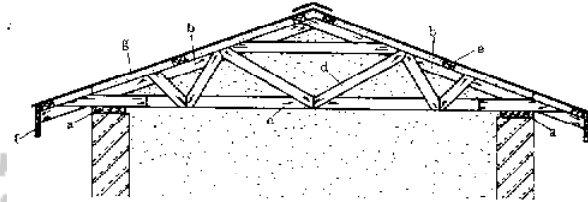

Fig 6.10: Gable roof (Source: Rural Building Course, Volume 1 – 2, 1995)

## 6.4 Roof Covering

### Alignment of the sheets

If possible, always start laying the sheets from one end of the roof so that the free ends of the sheets face away from the direction of the wind. This reduces the danger of the sheets being blown away as they are being installed.

Start laying from one end of the building to the other. As each new sheet is laid lift the edge of the previous one so that it overlaps the new sheet by 2 corrugations. Each sheet is thus



held in position by the one previously fixed, so they are more easily aligned in the correct position.

Exact side laps (2 corrugations) and end laps (15cm) are essential to make the roof water roof.

**Nailing:**

When you nail corrugated roofing sheets to purlins, always nail through the top of the corrugation and never on the valley. This is so that rain will tend to run away from the nail. The sheets should be nailed to all the purlins. Nail every second corrugation in the sheets along the eaves purlin and along the ridge purlin, and also on the end sheets at the gables, over the rest of the roof, nail at every third corrugation over the purlins.

For estimating purposes, 14 nails are allowed for one sheet; 4 of the ends, 3 at the middle the 3 rails are accounted for wastage.

**Number of covering sheets**

To estimate the number of sheets required to cover a given area of roof first you have to:

- Know the size (s) of sheet materials sold in the markets in your locality,

- The total length of one rafter in one side of the roof (i.e. in case of gable roof)
- The rise of the roof (this may be  $\frac{1}{4}$  -  $\frac{1}{10}$  of the roof truss span)
- The length of the tie beam
- The side lap and over lap of the sheets and
- The total length of the building

**Example:**-Let us see the following design of a “Gable Roof” and by applying the terms mentioned above be able to calculate the numbers of sheets required to cover a roof for the below given building.

Specifications about the building

- The building is 8m by 6m (external dimension)
- The wall thickness is 25cm
- A gable roof will be used to cover it
- Rise of the roof =  $\frac{1}{6}$ <sup>th</sup> of roof truss span
- Over hang projection = 29cm
- Two types of size of sheets, 2.50m x 80cm and 1.10m x 80 cm will be utilized
- Side lap over lap of the sheets are 15cm for each type of laps
- See below the pictorial representation of all the above specifications (fig. 6.11)

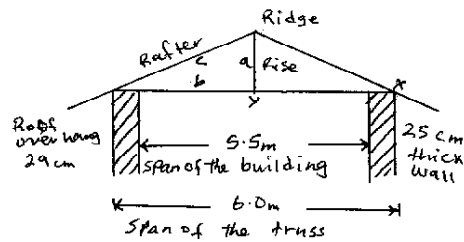

Fig 6.11: Number of covering sheets

Now let us work out to find the number of sheets required to cover the roof of the given building.

From the figure above, you can obtain the following data.

- Span of the truss: It is the horizontal distance between the internal faces of the rafters (x) at the point where they meet the tie beam (i.e. at x). Hence, from the diagram, span of the truss = 6.0m
- Tie beam: is the horizontal member of the roof structure with ties with the rafters at the point (x) where they meet. Hence, the length of tie beam from point x to point x = 6.0m.
- Rise: Is the vertical height from the centre (y) of the tie beam to the ridge.

Hence;

$$\text{Rise} = \frac{1}{6} \times \text{span of the truss},$$

$$\text{Rise} = \frac{1}{6} \times 6.0\text{m}$$

$$= 100 \text{ cm} = 1.0\text{m}$$

the distance from point x to point y

$$= 3\text{m (i.e. half of the length of the tie beam)}$$

A. Now, you can find the length of one rafter (i.e., the distance between the ridge and x), using the “Pythagoras theorem”.

- Therefore, the length of one rafter [c] can be calculated since the values for “a” and “b” are known. That is  $a=1.0\text{m}$ ,  $b=3.0\text{m}$ . thus,
- Length of one rafter [c] (i.e., from x up to the ridge point) is  $c^2 = a^2 + b^2$
- Rafter [c] =  $[a^2 + b^2]$  {under square root} =  $[1\text{m}^2 + 3\text{m}^2]$  {under square root} = 3.16m. That is the length from point ‘x’ to the ridge pint.

Then, total length of one rafter

$$\begin{aligned} &= \text{length of rafter} + \text{Length of overhang} \\ &\quad (\text{i.e., from x to } d=29 \text{ cm}). \\ &= 3.16\text{m} + 0.29\text{m} \\ &= 3.45\text{m}. \end{aligned}$$

B. Number of sheets required to cover the roof

The total length (i.e. 3.45m) is the breadth of the roof. Thus the number of sheets in a one row along the breadth of the roof can be found as following.

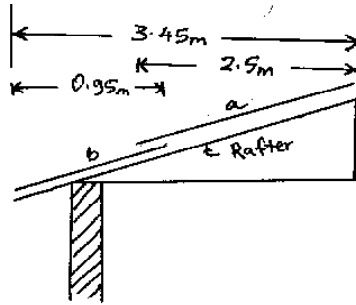

Fig. 6.12: Number of sheets

- First lay sheet "a" which 2.5m by 0.8m
- No only 95m is remained uncovered ( $3.45 - 2.5 = 0.95\text{m}$ )
- Next lay sheet "b" which is 1.10m by 0.8m overlapped by sheet "a" by 15cm \*i.e. in the diagram).
- Thus the effective length of sheet "b" is  $1.10\text{m} - 0.15\text{m} = 0.95\text{m} = 95\text{cm}$ .
- Then  $2.50 + 0.95 = 3.45\text{m}$
- Now we have made one row using one sheet 2.50m long and one sheet 1.10m long.
- That is: 1 sheet of 2.50m in length and 1 sheet 1.10 meter in length

**N.B** Now the total number of sheets is determined as follows:

- Number of sheets required along the length of the roof wood be  $\frac{\text{[Total length of the roof-width of sheet]}}{\text{[width of the sheet - overlap]}} + 1$

OR approximately: [total length of the roof]/ [width of sheet – overlap]

But, total length of the roof= length of the building + length of the overlap at the two ends of the building

$$\begin{aligned}\text{Total length of the roof} &= 8.0\text{m} + 0.15 + 0.15\text{m} \\ &= 8.30\text{m}\end{aligned}$$

The number of sheets required along the length of the roof

$$= [8.30 - 0.80] / [0.8 - 0.15] + 1 = 12.54, \text{ say } 13$$

OR approximately =  $8.30 / [0.8 - 0.15] = 12.54$ , say 13

**NB.** Total number of sheets required for both slopes

$$2.8 \text{ sheet} = 1 \times 13 \times 2 = 26$$

$$1.10\text{m sheet} = 1 \times 13 \times 2 = 26$$

### Review Questions

- 1) List at least three types of roofs.
- 2) Explain briefly the difference between a Gable roof and a Lean-to roof.
- 3) How would you estimate the number of sheets required to cover a given area of roof?
- 4) Draw a gable roof and show where the wall plate, rafters, purlines and tie beam are located.

## References

1. B.N. DUTTA (1991) Estimating and costing in civil engineering. Theory and practice, including specification and valuation.
2. Intermediate Technology Publications (1995) Rural Building, a reference book, volume one.
3. Intermediate Technology Publications (1995) Rural Building, basic knowledge, volume two.
4. Intermediate Technology Publications (1995) Rural Building, Construction, Volume Three.
5. Thomas D. Jordan Jr.(1984) a handbook of gravity-flow water systems for small communities, intermediate technology publication.