

Second Edition

KITCHEN & BATH PRODUCTS and MATERIALS

Cabinetry • Equipment • Surfaces



Ellen Cheever, CMKBD, ASID, CAPS

KITCHEN & BATH
PRODUCTS AND MATERIALS

KITCHEN & BATH
**PRODUCTS AND
MATERIALS**

Cabinetry, Equipment, Surfaces

Second Edition

ELLEN CHEEVER, CMKBD, ASID, CAPS

WILEY

NKBA[®]
National Kitchen & Bath Association

Cover image: Kitchen design by Pietro A. Giorgi, CMKBD, Joseph Giorgi, Jr., CKD, and Ellen Cheever, CMKBD, ASID, CAPS. Photo by Peter Leach. Bathroom design by Ellen Cheever, CMKBD, ASID, CAPS, Pietro A. Giorgi, Sr., CMKBD, and Joseph Giorgi, Jr., CKD. Photo by Peter Leach
Cover design: Wiley

This book is printed on acid-free paper. ♻️

National Kitchen & Bath Association
687 Willow Grove Street
Hackettstown, NJ 07840
Phone: 800-THE-NKBA (800-843-6522)
Fax: 908-852-1695
Website: NKBA.org

Copyright © 2015 National Kitchen and Bath Association. All rights reserved.

Published by John Wiley & Sons, Inc., Hoboken, New Jersey.
Published simultaneously in Canada.

No part of this publication may be reproduced, stored in a retrieval system, or transmitted in any form or by any means, electronic, mechanical, photocopying, recording, scanning, or otherwise, except as permitted under Section 107 or 108 of the 1976 United States Copyright Act, without either the prior written permission of the Publisher, or authorization through payment of the appropriate per-copy fee to the Copyright Clearance Center, 222 Rosewood Drive, Danvers, MA 01923, (978) 750-8400, fax (978) 646-8600, or on the web at www.copyright.com. Requests to the Publisher for permission should be addressed to the Permissions Department, John Wiley & Sons, Inc., 111 River Street, Hoboken, NJ 07030, (201) 748-6011, fax (201) 748-6008, or online at www.wiley.com/go/permissions.

Limit of Liability/Disclaimer of Warranty: While the publisher and author have used their best efforts in preparing this book, they make no representations or warranties with the respect to the accuracy or completeness of the contents of this book and specifically disclaim any implied warranties of merchantability or fitness for a particular purpose. No warranty may be created or extended by sales representatives or written sales materials. The advice and strategies contained herein may not be suitable for your situation. You should consult with a professional where appropriate. Neither the publisher nor the author shall be liable for damages arising herefrom.

For general information about our other products and services, please contact our Customer Care Department within the United States at (800) 762-2974, outside the United States at (317) 572-3993 or fax (317) 572-4002.

Wiley publishes in a variety of print and electronic formats and by print-on-demand. Some material included with standard print versions of this book may not be included in e-books or in print-on-demand. If this book refers to media such as a CD or DVD that is not included in the version you purchased, you may download this material at <http://booksupport.wiley.com>. For more information about Wiley products, visit www.wiley.com.

Library of Congress Cataloging-in-Publication Data:

Cheever, Ellen.

Kitchen & bath products and materials : cabinetry, equipment, surfaces / Ellen Cheever, CMKBD, ASID, CAPS. — Second edition.

pages cm
Includes index.

ISBN 978-1-118-77528-8 (cloth : alk. paper); 978-1-118-77529-5 (ebk.); 978-1-118-77531-8 (ebk.)

1. Kitchens—Equipment and supplies. 2. Bathrooms—Equipment and supplies. 3. Plumbing fixtures. I. Title. II. Title: Kitchen and bath products and materials.

TH4816.3.K58C5185 2015
643'.3—dc23

2014007308

Sponsors

The National Kitchen and Bath Association recognizes, with gratitude, the following companies whose generous contributions supported the development of this second edition volume of *Kitchen & Bath Products*, retitled *Kitchen & Bath Products and Materials*.

PLATINUM SPONSORS



WWW.COSENTINO-GROUP.NET



see what Delta can do™

WWW.DELTAFAUCET.COM/INDEX.HTML



WWW.WAYPOINTLIVINGSACES.COM

GOLD SPONSORS

HAFELE

SUB-ZERO WOLF

TRESCO LIGHTING BY REV·A·SHELF

WELLBORN CABINET INC.

About the National Kitchen & Bath Association

The National Kitchen & Bath Association (NKBA) is the only nonprofit trade association dedicated exclusively to the kitchen and bath industry and is the leading source of information and education for professionals in the field. Fifty years after its inception, the NKBA has a membership of more than 55,000 and is the proud owner of the Kitchen & Bath Industry Show (KBIS).

The NKBA's mission is to enhance member success and excellence, promote professionalism and ethical business practices, and provide leadership and direction for the kitchen and bath industry worldwide.

The NKBA has pioneered innovative industry research, developed effective business management tools, and set groundbreaking design standards for safe, functional, and comfortable kitchens and baths.

Recognized as the kitchen and bath industry's leader in learning and professional development, the NKBA offers professionals of all levels of experience essential reference materials, conferences, virtual learning opportunities, marketing assistance, design competitions, consumer referrals, internships, and opportunities to serve in leadership positions.

The NKBA's internationally recognized certification program provides professionals the opportunity to demonstrate knowledge and excellence as Associate Kitchen & Bath Designer (AKBD), Certified Kitchen Designer (CKD), Certified Bath Designer (CBD), and Certified Master Kitchen & Bath Designer (CMKBD).

For students entering the industry, the NKBA offers Accredited and Supported Programs, which provide NKBA-approved curriculum at more than 55 learning institutions throughout the United States and Canada.

For consumers, the NKBA showcases award-winning designs and provides information on remodeling, green design, safety, and more at NKBA.org. The NKBA Pro Search tool helps consumers locate kitchen and bath professionals in their area.

The NKBA offers membership in 11 different industry segments: dealers, designers, manufacturers and suppliers, multi-branch retailers and home centers, decorative plumbing and hardware, manufacturer's representatives, builders and remodelers, installers, fabricators, cabinet shops, and distributors. For more information, visit NKBA.org.

Contents

| | |
|---|-------------|
| PREFACE | xiii |
| ACKNOWLEDGMENTS | xv |
| | |
| CHAPTER 1 | |
| CABINETS | 1 |
| Cabinet Types | 2 |
| Responsible Resource Management in the Cabinet Industry | 5 |
| KCMA Certification Program | 9 |
| Cabinet Sizing Systems: Imperial and Metric | 12 |
| Cabinet Manufacturing Systems | 18 |
| Cabinet Interior Storage Systems | 23 |
| Cabinet Mechanical/Functional Hardware | 38 |
| Cabinet Sizes | 43 |
| Cabinet Core Materials | 58 |
| Cabinet Interior and Exterior Finish Materials/Systems | 61 |
| Typical Door Styles | 83 |
| Cabinet Millwork Design Details | 87 |
| Generic Cabinet Nomenclature | 89 |
| Summary | 90 |
| Review Questions | 90 |

CHAPTER 2
APPLIANCE TYPES AND PLANNING CONSIDERATIONS.....91
Selecting More Efficient Appliances 92
EnergyGuide and Energy Star Labels 92
Kitchen Food Preservation Center 96
Kitchen Waste Management 104
Cooking Center 108
Summary 135
Review Questions 135

CHAPTER 3
FIXTURE MATERIALS 137
Protecting Materials from Bacteria 137
Fixture Construction 138
Summary 151
Review Questions 151

CHAPTER 4
FIXTURE DESIGN AND PLANNING CONSIDERATIONS 153
Kitchen Sink And Bathroom Lavatory Fixtures 154
Toilet Fixtures 165
Bidet Fixtures 171
Residential Urinal Fixtures 173
Bathtub Fixtures 173
Shower Stall Fixtures 186
Bathtub/Shower Combination Unit Fixtures 190
Summary 191
Review Questions 192

CHAPTER 5
FITTING MATERIALS, ENGINEERING, AND CONFIGURATION 193
Construction Materials 194
Planning Considerations When
Combining Finishes 195
Kitchen and Bathroom Faucet
Fitting Engineering 199
Summary 210
Review Questions 210

| | |
|---|------------|
| CHAPTER 6 | |
| BATHTUB AND SHOWER FITTING | |
| DESIGN AND ENGINEERING..... | 211 |
| Bathtub Fittings | 211 |
| Bathtub/Shower Combination Fittings | 215 |
| Shower Fittings | 216 |
| Steam Showers And Saunas | 226 |
| Summary | 230 |
| Review Questions | 231 |
| | |
| CHAPTER 7 | |
| SURFACING MATERIALS..... | 233 |
| Sustainable Choices | 233 |
| Solid Wood Counter Surfaces | 234 |
| Cast Polymers: Counter Surfaces And Wet Wall Surfaces | 236 |
| Ceramic Tile: All Surfaces | 239 |
| Concrete | 257 |
| Cork Flooring | 258 |
| Glass Surfaces | 259 |
| Hardwood Flooring | 261 |
| Laminates | 263 |
| Paint | 268 |
| Quartz Composite | 269 |
| Solid Surfacing | 271 |
| Metal Countertops | 272 |
| Stone | 273 |
| Vinyl Resilient Flooring | 282 |
| Wallpaper | 282 |
| Summary | 284 |
| Review Questions | 284 |
| | |
| APPENDIX A: GENERIC CABINET NOMENCLATURE | 285 |
| APPENDIX B: APPLIANCE CHECKLIST | 321 |
| GLOSSARY | 327 |
| RESOURCES..... | 339 |
| INDEX..... | 345 |

Preface

A key ingredient in any successful new kitchen or bathroom project is the right match between the client's dreams, the project budget, the construction of the dwelling and the materials, equipment, and surfaces specified by the design professional.

New manufacturing methods, engineering innovations, and technological advancements continually impact the materials, equipment, and surfaces available to kitchen and bathroom planners. Therefore, a book on products for residential kitchens and bathrooms must be updated periodically. This is what the National Kitchen & Bath Association (NKBA) has undertaken in conjunction with John Wiley & Sons, Inc., in the second edition of this volume.

In this revised edition, we have maintained the organization found in the original edition. Seven major chapters cover the choices available to professionals.

Chapter 1 details the kitchen and bathroom cabinet industry. In addition to identifying cabinet manufacturing systems, extensive information has been added detailing storage systems integrated into cabinet interiors. This information extends beyond kitchen ideas and includes storage systems for entertainment and refreshment areas, utility rooms, and home offices.

New information about cabinet case construction materials is highlighted. Information about working veneers has been expanded as well. The Kitchen Cabinet Manufacturers Association (KCMA) Responsible Resource Management Program and the association's Certification Program are detailed.

We have included a review of cabinet manufacturers' imperial (inches/feet) and metric (millimeters/centimeters) dimensioning systems. While this information is useful, we recommend designers work closely with their chosen manufacturer to understand the cabinet sizing system the specific supplier has embraced.

Chapter 2 details appliance types and planning considerations. New information has been added to explain new heat transference methods, and point-of-use specialized appliances. Because of major innovations taking place within the ventilation category of appliances, extensive material has been added about this topic as well.

Chapter 3 covers fixture materials. In addition to new materials being used for kitchen sinks, bathroom lavatories, and other bathroom fixtures, construction and fabrication information, and ideas about how and where to use new materials are a part of this second edition.

Chapter 4 covers fixture design and planning considerations. Information has been added in the section covering new engineering technologies that have dramatically improved water

usage of kitchen and bathroom fixtures. Additionally, extensive new graphics have been added to demonstrate the product choices available today.

In Chapter 5, the topics of fitting materials and engineering are covered. New information about fashionable finishes for faucetry has been highlighted. Hands-free methods of operations for faucets are explained as well.

Chapter 6 covers bathroom fitting design and engineering. Water conservation is, once again, an important topic covered in this section. The technology behind new showering fixtures is included.

Chapter 7, our final chapter, focuses on surface materials. Expanded details about domestic and imported ceramic and porcelain products are discussed. New materials are explained: concrete and glass, for example. The information on laminate surfaces now includes a discussion of the new high-definition finishes.

The overall volume is written to help new designers begin their professional path as well as to provide a resource for experienced designers interested in updating their existing knowledge about newly launched products or products recently reengineered.

Designers are encouraged to reference additional information through the resources available on the Internet. Because of the ever-changing landscape of materials, products, and surfaces available, time set aside for purposeful research should be a weekly exercise for the design professional.

We hope the material in this volume assists designers as they creatively lay out a kitchen or bathroom solution and begin the selection and specification tasks of recommending the materials, equipment, surfaces, and the products necessary to transform a beautiful drawing into a hardworking kitchen or restful and relaxing bathroom space.

Acknowledgments

The NKBA gratefully acknowledges the following peer reviewers of this book:

Peter Albanese, CKD, CBD

Corey Klassen, CKD, CBD

Richard Lensis, CKD, CBD, LEED

David Newton, CMKBD

Lilley Yee, CMBD, ASID, CID

The author wishes to also recognize several professional colleagues whose contributions made this book possible.

When I published my first book in 1978, *Beyond the Basics: Advanced Kitchen Design*, I began my acknowledgments by saying, "The creation of this book is the result of the cooperation and contributions of many talented people." Some 36 years later as I complete this volume, I feel the same sentence is appropriate.

It would not have been possible for me to complete this work without the help of my team; they deserve a special expression of gratitude and recognition. Thank you for helping me write this book and for being my friends.

Cathy Snyder has served as my associate for 25 years. She has transcribed, edited, and proofed every sentence I have ever written over all those years. Additionally, she has managed my office and organized my activities.

Karen Dorion, CKD, has transformed my design concepts into accurate drawings for the past 20 odd years as well. I dream, she creates. From training program diagrams, to project documents Karen has ensured accuracy in my work.

Pete Giorgi, CMKBD, and the Giorgi Kitchens and Designers management team has given me an opportunity to continue to practice as a residential kitchen and bath designer. This work has helped me maintain a real-world practical approach in my writing and teaching endeavors.

One last person I would also like to recognize and thank is Johanna Baars. As the NKBA publications specialist, she has been responsible for managing this massive project from concept to reality. It has been a pleasure to work with such a talented, organized, and pleasant professional.

Cabinetry



One of the largest components of a residential kitchen or bathroom is the storage system planned for the space. An organized storage area is also important in laundry rooms, hobby centers, home offices, closets, and dressing rooms.

Learning Objective 1: Describe the differences between frame and frameless cabinetry as it relates to case construction material and sizing differences.

Learning Objective 2: Recognize some of the sources offering interior storage systems.

Learning Objective 3: Explain the difference between cabinet doors or fronts constructed from solid woods versus veneer surfacing materials.

Learning Objective 4: Provide a comprehensive listing of planning concerns when working with vendors.

Learning Objective 5: Outline the key categories of the KCMA Certification Program process and the KCMA Environmental Stewardship Program.

Learning Objective 6: Identify typical cabinet configurations and available sizing for kitchens, bathrooms, and other home storage centers.

Design professionals in the kitchen and bathroom industry may be representatives of specific manufactured cabinet companies or may have a referral relationship with area showrooms that represent different cabinet companies. Some design professionals, known as *independent kitchen designers*, do not align themselves with any specific cabinet company. They develop plans based on generic cabinet specifications and then invite their clients to source products from kitchen dealerships representing large manufacturing companies or smaller local manufactured cabinetry.

Within the cabinet industry, broad categories are used to identify the configuration of the cabinet, the availability of custom sizing, the sophistication of interior cabinet accessory systems, and the variety of finishes and architectural accouterments offered by the producer.

In North America, kitchen cabinets historically were built by local cabinet or woodworking shops and were created for each project. Today, a great majority of kitchen cabinet systems is produced in highly sophisticated manufacturing facilities, both in North America and internationally. There are sizing differences between cabinets built in the United States and those built in Canada and internationally.

As a design professional, you may work for a retail organization representing specific cabinet manufacturers or directly for a cabinet manufacturer or distributor. You may work for a company that actually fabricates cabinets in a woodworking shop. Or you may be familiar with cabinets in general sense but focus your work on creating a generic space plan.

Regardless of how you interact with the cabinet source, it is important that you are familiar with:

- How the cabinets are built
- The functional hardware available for various cabinet components
- The special-purpose storage systems integrated inside cabinetry
- Materials used on the exterior of the cabinetry
- Door and front styles typically offered by manufacturers
- The industry's efforts to responsibly manage these resources

CABINET TYPES

Regardless of the type of business you are affiliated with, in North America cabinet specifiers work with four broad categories. Within each of these, the quality levels, production costs, retail selling price, delivery schedules, and reliability factors vary. The following stock, semi-custom, custom, and millwork cabinetry definitions apply to the United States. (What is called a semi-custom cabinet in the United States is called a custom cabinet in the international community.)

Stock

Stock cabinet manufacturers offer a full range of cabinets in specified sizes designed to meet the needs of most consumers at a cost-effective price. They offer the most popular door styles, finishes, and accessories with limited modifications, and the cabinets may be in stock at cabinet distributors, home centers, and lumberyards. Because stock cabinets are produced in quantity, the cabinet manufacturers cannot stop their assembly lines for special units; therefore, their catalogs generally reflect the entire product offering.

This type of manufacturing method provides the specifier good value because of the economies of manufacturing. The biggest advantages of stock cabinetry are its availability, specified quality level, and consistency of service from large, stable manufacturers. Stock cabinets offer an excellent product for a project that has budget or time constraints. Because styles and special sizes are limited, you should investigate the breadth of the line before designing with the product.

However, designers need not forgo creative cabinet design when using stock cabinets. Once you are familiar with the line, consider adapting specific case types to usage ideas appropriate for the project you are working on. For example, use wall cabinets as shallow base units by adding a toe-kick.

Stock cabinets do vary in quality levels. Some lines use doors of mismatched or lower-quality woods. They may use thin laminates or actual paper products to simulate wood on finished sides. The parts of the case may be glued together with no mechanical fasteners, which is not as durable a method of case construction as combining both glue and mechanical fasteners. Make sure you carefully compare the construction of the stock cabinets you are considering for the project you are designing. One line may be just right for a laundry room application, while a sturdier product may be required for the adjacent kitchen. The cabinets shown in Figure 1.1 are an example of stock cabinets.

Semi-Custom

Semi-custom cabinets are produced by both stock and custom manufacturers. This type of product is produced on an assembly-line basis, but the offerings include more interior fittings



FIGURE 1.1 A kitchen using stock cabinets
 Courtesy of Wellborn Cabinet, Inc.

in the form of accessories and some custom cabinet size possibilities. Typically, a wider finish and style palette is offered as well.

This product combines the advantage of an assembly-line process with the ability to create limited custom cabinet sizes. Traditionally, semi-custom products also offer more door styles and finishes.

Semi-custom cabinets come in a wide variety of quality and price levels. Because they may be high on style but limited in their size offerings, review the manufacturer's catalog carefully before beginning the design process. The cabinets shown in Figure 1.2 are an example of semi-custom cabinets.



FIGURE 1.2 A kitchen using semi-custom cabinets
 Courtesy of Wellborn Cabinet, Inc.



FIGURE 1.3 A kitchen using custom cabinets

Courtesy of Plain & Fancy Custom Cabinetry

International cabinet producers who focus on finely engineered specific styles—used to define their cabinet branding—neither recommend nor offer extensive customization. Therefore, the manufacturing definition of semi-custom defines their highest level of product offering.

Custom

Custom cabinet manufacturers make one kitchen at a time. The cabinets are not produced until the kitchen has been designed and all details are finalized. Custom cabinets may be made by a local fabricator or in a large manufacturing facility. Generally, these manufacturers publish a specifications manual listing a range of specific cabinet sizes, but special sizes are available for a perfect fit. One-of-a-kind, handmade specialty pieces, such as mantel hoods, turned-wood posts, curved/angled cabinetry elements, and free-standing furniture pieces are also available.

These totally custom *built-to-order* cabinets are considered *furniture-grade* cabinet systems. The cabinets shown in Figure 1.3 are an example of custom cabinets. Manufacturers of such cabinets generally offer the latest in functional hardware, technology, construction methods, and case materials and the most extensive array of accessories available. These companies offer new, trendsetting styles and finishes to the market. Custom cabinets have a longer lead time than stock or semi-custom offerings. Much like custom furniture, an 8- to 20-week delivery time is to be expected.

Millwork Cabinetry

Cabinetry defined as *millwork* is produced just as custom cabinets are. In addition, millwork companies produce their own panel stock as well as the cabinet door collection offered. This allows for grain that is more sophisticated and color matching throughout the kitchen exteriors and for additional paneling that may be used within the nonstorage sections of the room. The cabinetry pictured in Figure 1.4 is an example of millwork. The millwork house also may offer elaborately constructed custom furniture pieces that are assembled prior to finishing within the manufacturing facility and shipped as one entire piece.



FIGURE 1.4 A kitchen using millwork cabinetry

Design by Pietro A. Giorgi, Sr., CMKBD, and Ellen Cheever, CMKBD, ASID, CAPS, Giorgi Kitchens & Designs. Photo by Peter Leach

International Definitions of Kitchens

- Custom-made, English “bespoke” or “one-off” kitchen: A set of cabinets made specifically for one client or one project.
- Fitted kitchen: A set of cabinets sized and scribed to the room, allowing the cabinetry to become part of the woodwork of the house.
- Unfitted kitchen: A set of cabinets that are not scribed to the walls, ceiling, or floor of the room. Although they are secured to the wall for stability, they appear more like furniture than casework.

RESPONSIBLE RESOURCE MANAGEMENT IN THE CABINET INDUSTRY

Because forests provide numerous environmental benefits, it is essential that we protect and sustain them. They moderate climate change, improve air quality, aid in water conservation, and preserve biodiversity. In order to maintain these benefits and ensure that forests meet long-term human needs, it is vital we practice sustainable forestry.

Sustainable forestry practices ensure that the resources removed from forests are at a level the forests are capable of renewing without damaging their future prosperity. Sustainable practices preserve the environment and valuable forest resources. In addition to sustainable forestry, most certification programs support selective harvesting.

Selective harvesting is the practice of periodically removing mature trees in order to allow young trees to grow. Trees that are near their death or have grown to an unproductive diameter can stunt younger trees from growing properly. By periodically harvesting

particular trees, forest regeneration is improved. Selective harvesting leads to a healthier forest, thus preserving the environment and the social benefits forests provide. This practice of selective harvesting is also referred to as “a managed forest” or “managing the forest.”

From Forest to Cabinets: Protecting the Environment while Creating Beautiful Kitchens and Bathrooms

Within the global community, the United States is envied for its natural wood resources; according to the US Forest Service, approximately one-third of our nation’s land area is forestland. Canada is also a nation rich in wood natural resources.

Within North America, about one-third of all our forests are considered hardwood forests, with 90 percent of them located in the eastern United States. Hardwood trees require from 50 to 120 years to reach a harvestable size. Approximately 50 percent of the lumber produced is not useable for kitchen, bath, or other fitted room cabinetry because it contains characteristics not accepted in furniture.

In today’s foresting industry, managed forestlands are far more the norm than unmanaged lands. The industry is working feverishly to grow trees fast enough to be harvested to meet the demand for hardwoods while managing forests for future yield. The term “old growth” refers to large trees that have grown in natural forests. Smaller, younger trees are grown on farms specifically to be harvested for the furniture, cabinetry, and building industries.

What does managed forestry mean to the kitchen or bathroom designer? From a design standpoint, logs harvested from managed forests can have a different appearance than those from *old-growth* logs. Therefore, it is almost impossible to create new cabinetry that has the same aesthetic as antique furniture. The width of wood planks available today and the acceptability of certain wood characteristics have changed. Equally if not more important is the fact that the lack of oversight in the harvesting of veneers and wood products elsewhere in the world have led conservationists to develop certifications attesting to the responsible resource management of all types of wood producers: notably, cabinet manufacturers. Responsible designers specify products that have recognized certification.

Certified Wood

Over 50 certification programs worldwide address the many types of forests around the world. In addition to both US and Canadian government programs, two important certification programs specifically relate to kitchen cabinetry: the Forest Stewardship Council (FSC) and the Environmental Stewardship Program (ESP) managed by the Kitchen Cabinet Manufacturers Association (KCMA).

For the purposes of this volume on kitchen and bathroom materials, we focus on the KCMA ESP. Additional information can be gathered at www.kcma.org as well as KCMA’s website, www.GreenCabinetSource.org.

KCMA Environmental Stewardship Program

In all categories of materials for residential kitchens, there are products that are considered green. The KCMA developed the Environmental Stewardship Program (ESP), which holds the cabinet industry to higher standards than other environmental programs because of its holistic approach to manufacturing, examining the process from growth and harvesting of raw materials to manufacturing the end product (see Figure 1.5).



FIGURE 1.5 Kitchen Cabinet Manufacturers Association Environmental Stewardship Program

Since the program's inception in 2006, the ESP certification requirements have been based on currently attainable materials and have been amended as new, improved materials became available. In January 2012 the criteria were changed to address formaldehyde emission limits.

The KCMA ESP takes a holistic approach to environmental stewardship, providing companies with tangible ways to support sustainability in areas of air quality, product resource management, process resource management, environmental stewardship, and community relations. The program is a point-based evaluation system, with companies qualifying for official ESP certification by accumulating 80 out of a possible 105 points in five categories. Full details of the program can be reviewed at www.kcma.org/Professionals/Environmental_Stewardship_Program.

Responsible Resource Management Criteria

Reprinted Courtesy of the Kitchen Cabinet Manufacturers Association

Following is an overview of the responsible resource management criteria.

Air quality

- Mandatory requirement: 100 percent of particleboard, medium-density fiberboard, and plywood used in the cabinets must meet the formaldehyde emission level of the California Air Resources Compwood ATCM [airborne toxic control measure] and must be third-party certified to meet low-formaldehyde-emission standards.
- 75 percent of cabinets must be finished in the United States or Canada. Finishes can emit no greater hazardous air pollutants than allowed by local plant operating permits.

Product resource management

- 80 percent of particleboard and medium-density fiberboard used in cabinets must contain 100 percent recycled or recovered fiber content.
- Manufacturers earn points if they have kitchen cabinets that are also chain-of-custody (COC) certified through a recognized sustainable forestry program.
- Hardwoods, softwoods, and plywood purchased are COC certified through a recognized sustainable forestry program.
- Hardwood and softwood lumber are certified-sourcing certified through a recognized sustainable forestry program.
- Manufacturers utilize an annual, written training plan to educate their hardwood suppliers of their preference for purchasing certified lumber.

Process resource management

- Manufacturer has a comprehensive recycling program for process wastes.
- Manufacturer has a program for tracking and reducing process wastes with documented goals and reports.
- Manufacturer uses processed byproducts to generate alternative energy.
- Manufacturer has a documented energy conservation program.

Environmental stewardship

- Manufacturer is required to have a written policy stating a firm commitment to environmental quality.
- Manufacturer has an environmental management system.
- Manufacturer reviews environmental practices and policies of its key vendors and contractors.

(continued)

- Manufacturer has a documented program that promotes the use of renewable/recycled materials.

Community relations

- Manufacturer demonstrates community involvement and leadership through service or charitable organizations.
- Manufacturer observes all federal, state, and local environmental requirements.

Mandatory requirement: ESP participant agrees to report to KCMA within 60 days of any local, state, or federal citation in excess of \$50,000 per violation, explaining the circumstances of the citation or violation. Such citation or violation could lead to termination from the program.

Points are awarded for meeting each of these criteria. Manufacturers must earn at least 80 of a possible 105 points and must earn points from each category to be certified.

Available at www.greencabinetsource.org/Learn_about_ESP/Certification_Requirements

Debate around the Dangers of Formaldehyde

Both clients and designers are worried about the formaldehyde emission risk in cabinets manufactured outside the United States as well as within our borders. The ESP certification was updated in 2012, restricting materials to only those that had low-formaldehyde-emitting levels.

There are two general schools of thought regarding the danger of formaldehyde emissions.

- One group of experts believes that formaldehyde is a toxic material that should be eliminated. There are cabinet materials that are formaldehyde-free.
- A second group of experts believes that products can emit very low levels of formaldehyde and be considered safe for the vast majority of users.

KCMA has published the following informational overview of wood products and the emissions of formaldehyde.

WOOD & EMISSIONS

Wood products, such as those used in cabinets, can emit low amounts of formaldehyde

Formaldehyde, a naturally occurring chemical present in human breath, is widely used. It has been studied extensively and is typically encountered in the home in low levels. Like many other chemicals, if encountered in high levels, it can have negative health effects. Most people have no reaction to low-level formaldehyde emissions, but a small percentage of the population has acute sensitivity to it and other chemicals.

All wood species, and therefore all wood products, contain and emit small amounts of formaldehyde. An oak tree, for example, emits 9 parts per billion (ppb) of formaldehyde. It follows that any wood cut from that oak tree also contains small amounts of formaldehyde, as do all wood products. Formaldehyde also is found naturally in a wide range of fruits, vegetables, mushrooms, seafood, meats, and coffee.

(continued)

All cabinetmakers use composite wood in the construction of cabinets. It is an essential material for industry products extending the yield from the harvest of trees, making cabinetry more affordable. Composite wood generally is made with small amounts of urea formaldehyde adhesives in order to achieve durability and performance expected by consumers in the difficult kitchen environment that varies exposure to extreme heat, cold, diverse cooking products (mustard, ketchup, alcohol, and the like), detergents, water and heavy usage.

Action to Manage Formaldehyde Exposure in the Home

If you are among those with known sensitivities to formaldehyde, the US Department of Health and Human Services (HHS) recommends that consumers do the following to prevent exposure to formaldehyde:

1. Use lower-emitting pressed wood products, such as those that are labeled CARB (California Air Resources Board) compliant, or made with ultra-low-emitting formaldehyde (ULEF) or no-added formaldehyde (NAF). **Cabinets displaying the KCMA Environmental Stewardship Program (ESP) certification seal are required to use 100 percent CARB compliant pressed wood.** Beginning 2013, all pressed wood sold in the US must be CARB compliant. The CARB product emission standards are the lowest in the world.
2. Increase ventilation, particularly after bringing new sources of formaldehyde into the home. Open windows and use fans to bring in fresh air. The kitchen and bath generally already are the best ventilated rooms in a house with frequent air exchanges the norm.
3. Use air conditioning and dehumidifiers to maintain moderate temperature and reduce humidity levels.
4. Studies have shown that readily available laminated products are among the lowest emitters of formaldehyde.

KCMA ESP certified cabinetry meets the HHS guidelines for managing formaldehyde exposure. A recent study of formaldehyde by the National Academy of Sciences stated that the emission levels to which most consumers would be exposed are well below thresholds that would cause harm. This would include ESP certified cabinets.

From GreenCabinetSource.org, the website of the Kitchen Cabinet Manufacturers Association (www.greencabinetsource.org/Manufacturing/Wood_and_Emissions)

Designers should base their specifications on the client's level of sensitivity to formaldehyde emissions and request for formaldehyde-free products. Designers also should take a proactive role in continuing their education around this important issue that faces our industry, staying abreast of new research and/or product innovations.

KCMA CERTIFICATION PROGRAM

In addition to responsible resource management certification, KCMA has managed a Performance Testing and Certification Program for cabinet construction.

While many good-quality cabinets are not certified, in some markets and situations it is important to end users to have certified cabinets. Therefore, it is important for you as a

designer to be aware of the certification requirements for cabinet construction and durability. Cabinets and bathroom vanities bearing the KCMA Certification have met or exceeded the necessary requirements and are recommended by KCMA.

You should also be aware of the KCMA certification requirements (see “About the KCMA Certification Program”) so you can recommend cabinets that meet or exceed these standards of manufacturing to your clients.

About the KCMA Certification Program

Reprinted Courtesy of the Kitchen Cabinet Manufacturers Association

KCMA sponsors the nationally recognized voluntary testing and certification program for cabinets, ANSI/KCMA A161.1, Performance and Construction Standard for Kitchen and Vanity Cabinets. The program is referenced by US government agencies, architects, builders, remodelers, and other specifiers. Cabinets that comply and bear the KCMA certification seal [see Figure 1.6] are recognized in the marketplace as quality products able to perform after a rigorous battery of tests simulating years of typical household use.



FIGURE 1.6 ANSI/KCMA logo
Courtesy of Kitchen Cabinet
Manufacturers Association

Tests are performed by approved third-party independent laboratories. Samples for testing are selected in an unannounced visit to the manufacturing plant.

- The KCMA Certification Program assures the specifier or user of kitchen cabinets and bath vanities that the cabinet bearing the blue and white seal complies with the rigorous standards set by the American National Standards Institute (ANSI) and sponsored by the Kitchen Cabinet Manufacturers Association (KCMA). Further, the cabinet is an exact duplicate of samples that have been independently tested for conformance to ANSI/KCMA A161.1-2000.
 - The KCMA Certification Program is open to all cabinet manufacturers. Manufacturers may certify one, several, or all of their cabinet lines. Because of this option, only those lines certified are listed in the annual KCMA Directory of Certified Cabinet Manufacturers.
 - Compliance with ANSI/KCMA standards is assured by initial cabinet testing, periodic unannounced plant pick-up and testing, and additional testing resulting from complaints. All testing is performed by an experienced independent laboratory.
- These cabinets also comply with the provision of Paragraph 611-1.1, “HUD Minimum Property Standards—Housing 4910.1” 9/8/86.
 - Companies not licensed with the KCMA Certification Program may not claim or imply conformance with these standards for their products. KCMA, as the proprietary sponsor, reserves the right to question any claims of conformance and to test the products of any manufacturer making such claims. Should KCMA discover that a manufacturer is falsely representing that his products meet these standards, KCMA will take appropriate legal action.

Requirements Cabinet Must Meet to Earn the KCMA Certification Seal

- All cabinets must be fully enclosed with backs, bottoms, sides, and tops on wall cabinets; and backs, bottoms, and sides on base cabinets, with certain specified exceptions on kitchen sink fronts, sink bases, oven cabinets, and refrigerator cabinets.
- All cabinets designed to rest on the floor must be provided with a toe space at least two inches deep and three inches high.
- All utility cabinets must meet the same construction requirements as base and wall cabinets.
- Doors and drawers must be properly aligned, have means of closure, and close without excessive binding or looseness.
- All materials must ensure rigidity in compliance with performance standards.

(continued)

- Face frames, when used, must provide rigid construction.
- For frameless cabinets, the ends, tops/bottoms, and back shall be of thickness necessary to provide rigid construction.
- Corner or lineal bracing must be provided at points where necessary to ensure rigidity and proper joining of various components.
- All wood parts must be dried to a moisture content of 10 percent or less at time of fabrication.
- All materials used in cabinets must be suitable for use in the kitchen and bath environment where they may be exposed to grease, solvents, water, detergent, steam and other substances usually found in these rooms.
- All exterior exposed surfaces and edges, except the edges of end panels and the edges of back panels, shall be free of saw marks and other imperfections and shall be filled and sanded, edge-banded, or otherwise finished to ensure compliance with the performance standards.
- All exterior exposed parts of cabinets must have nails, staples set, and holes filled.
- All exposed construction joints must be fitted in a workman-like manner consistent with specifications.
- Exposed cabinet hardware must comply with Builders Hardware Manufacturing Association finishing standards.

Test Cabinets Must Pass to Earn the KCMA Certification Seal

- All shelves and bottoms are loaded at 15 pounds per square foot, and loading is maintained for seven days to ensure that there is no excessive deflection and no visible sign of joint separation or failure of any part of the cabinets or the mounting system.
- Mounted wall cabinets are gradually loaded to 600 pounds without any visible sign of failure in the cabinet or the mounting system.
- To test the strength of base-front joints, a load of 250 pounds is applied against the inside of cabinet-front stiles for cabinets with drawer rail, or 200 pounds is applied for cabinets without drawer rail, to ensure reliable front joints that will not open during stress in service or during installation.
- To test the ability of shelves, bottoms, and drawer bottoms to withstand the dropping of cans and other items, a three-pound steel ball is dropped from six inches above the surface. After the test, the drawer must not be damaged and must operate as before the test with no visible sign of joint separation or failure of any part of the cabinet or mounting system.
- To test the ability of cabinet doors and connections to withstand impacts such as children may cause in falling against a cabinet, a 10-pound sandbag is used to strike the center of a closed cabinet door and repeated with the door opened to a 45-degree angle. The door must operate as before the test and show no damage or sign of separation or failure in the system.

Two Drawer Tests Required

- To test the ability of drawers and drawer mechanisms to operate with loading during normal use, drawers are loaded at 15 pounds per square foot and operated through 25,000 cycles. The drawers must then remain operable with no failure in any part of the drawer assembly or operating system, and drawer bottoms must not be deflected to interfere with drawer operation.
- To test the ability of the drawer-front assembly to withstand the impact of closing the drawer under normal use, a three-pound weight is dropped 8 inches against the drawer assembly. After 10 drops, there must be no evidence of looseness or structural damage to the drawer-front assembly that impairs operation.

Two Door Operation Tests Measure Durability

- To test the ability of doors, hinges, and means of attachment to withstand loading, 65 pounds of weight is applied on the door. The weighted door is slowly operated for 10 cycles from 90 degrees open to 20 degrees open and returned to the 90-degree position. The door must remain weighted for 10 minutes, after which the door and hinges must show no visible signs of damage, and connections between cabinet-and-hinge and door-and-hinge must show no sign of looseness.

(continued)

- To test the ability of doors, door-holding devices, hinges, and attachment devices to operate under the stress of normal use, doors are opened and closed through a full 90-degree swing for 25,000 cycles. At the test's conclusion, the door must be operable, the door-holding device must hold the door in closed position, hinges must show no visible signs of damage, connections between cabinet-and-hinge and door-and-hinge must show no sign of looseness, and other specifications must be met.

Four Finish Tests Conducted

- These tests create, in accelerated form, the cumulative effects of years of normal kitchen conditions of pre-finished cabinets. Cabinet finishes are inspected to ensure that stringent standards of appearance are also met. To test the ability of the finish to withstand high heat, a cabinet door is placed in a hotbox at 120 degrees Fahrenheit and 70 percent relative humidity for 24 hours. After this test, the finish must show no appreciable discoloration and no evidence of blistering, checks, or other film failures.
- To test the ability of the finish to withstand hot and cold cycles for prolonged periods, a cabinet door is placed in a hotbox at 120 degrees Fahrenheit and 70 percent relative humidity for one hour, removed and allowed to return to room temperature and humidity conditions, and then placed in a coldbox for one hour at -5 degrees Fahrenheit. The cycle is repeated five times. The finish must then show no appreciable discoloration and no evidence of blistering, cold checking, or other film failure.
- To test the ability of the finish to withstand substances typically found in the kitchen and bath, exterior exposed surfaces of doors, front frames, drawer fronts and end panels are subjected to vinegar, lemon, orange and grape juices, tomato catsup, coffee, olive oil, and 100-proof alcohol for 24 hours and to mustard for one hour. After this test, the finish must show no appreciable discoloration, stain, or whitening that will not disperse with ordinary polishing and no indication of blistering, checks, or other film failure.
- To test the ability of the finish to withstand long periods of exposure to a detergent and water solution, a cabinet door edge is subjected to exposure to a standardized detergent formula for 24 hours. The door edge must then show no delamination or swelling and no appreciable discoloration or evidence of blistering, checking, whitening, or other film failure.

Available at www.kcma.org/Homeowners/Performance_Testing_and_Certification_Program

Industry Acceptance of the KCMA Environmental Stewardship Program

In 2007, the National Association of Home Builders and the International Code Council collaborated to establish a nationally recognizable standard definition of green building. ANSI has approved the National Green Building Standard (NGBS). This standard references KCMA's ESP and awards points for attaining such certification for kitchen cabinetry. This endorsement satisfied the rigorous ANSI requirements for balance and openness. The NGBS remains the only *green* standard recognized by ANSI.

CABINET SIZING SYSTEMS: IMPERIAL AND METRIC

Because the cabinet industry is an international one, there are two common methods of sizing cabinets: the English Imperial system, based on inches, and the International Metric Standard. Cabinets produced in the United States use the English Imperial system and, therefore, build cabinets in inch dimensions. Cabinets produced in other parts of the world use metric dimensioning.

Sometimes metric cabinets are referred to as *32 mm* or *System 32* cabinets. The term "32" refers to the basic metric sizing of all these cabinets: All the holes, hinge fittings, cabinet

joints, and mountings are set 32 millimeters (mm) apart. This spacing is based on the boring equipment used in the manufacturing process.

An exact translation between the two systems is called a *hard conversion*. The resulting converted inches, millimeters, or centimeters is mathematically correct but is not used in the international cabinet manufacturing industry. Designers must be aware that the two measuring systems do not produce cabinets of the exact same sizing. Planners should work in the sizing system used by their cabinet manufacturer and avoid converting between the two systems if possible. If a conversion is necessary, most drawing programs provide a hard conversion option. Numerous smart phone apps are available to provide such a conversion.

Cabinet manufacturers in the United States give product dimensions in inches. Canadian companies often use both imperial and metric measurements. Most European cabinet companies use metric dimensions for their cabinets. We have included Tables 1.1 and 1.2 listing hard metric conversions. The information given in the balance of this book lists imperial dimensions in inches in most cases. Other metric conversions can be found in various tables available on the Internet and in apps.

TABLE 1.1 Metric Conversions

| From Metric to Imperial | | | From Imperial to Metric | | |
|-------------------------|-------|-----------------------|-------------------------|---------|--------|
| mm | cm | Inches | Inches | mm | cm |
| 2.5 | 0.25 | $\frac{1}{8}$ " | $\frac{1}{16}$ " | 1.59 | 0.16 |
| 5.0 | 0.50 | $\frac{3}{16}$ " | $\frac{1}{8}$ " | 3.18 | 0.32 |
| 7.5 | 0.75 | $\frac{5}{16}$ " | $\frac{1}{4}$ " | 6.35 | 0.64 |
| 10.0 | 1.00 | $\frac{3}{8}$ " | $\frac{3}{8}$ " | 9.53 | 0.95 |
| 12.5 | 1.25 | $\frac{1}{2}$ " | $\frac{1}{2}$ " | 12.70 | 1.27 |
| 15.0 | 1.50 | $\frac{5}{8}$ " | $\frac{5}{8}$ " | 15.88 | 1.59 |
| 17.5 | 1.75 | $\frac{11}{16}$ " | $\frac{3}{4}$ " | 19.05 | 1.91 |
| 20.0 | 2.00 | $\frac{3}{4}$ " | $\frac{7}{8}$ " | 22.23 | 2.22 |
| 22.5 | 2.25 | $\frac{7}{8}$ " | 1" | 25.40 | 2.54 |
| 25.0 | 2.50 | 1" | 3" | 76.20 | 7.62 |
| 50.0 | 5.00 | 2" | 6" | 152.40 | 15.24 |
| 100.0 | 10.00 | 4" | 9" | 228.60 | 22.86 |
| 150.0 | 15.00 | 5- $\frac{7}{8}$ " | 12" | 304.80 | 30.48 |
| 200.0 | 20.00 | 7- $\frac{7}{8}$ " | 15" | 381.00 | 38.10 |
| 250.0 | 25.00 | 9- $\frac{7}{8}$ " | 18" | 457.20 | 45.72 |
| 300.0 | 30.00 | 11- $\frac{13}{16}$ " | 21" | 533.40 | 53.34 |
| 350.0 | 35.00 | 13- $\frac{3}{4}$ " | 24" | 609.60 | 60.96 |
| 400.0 | 40.00 | 15- $\frac{3}{4}$ " | 27" | 685.80 | 68.58 |
| 450.0 | 45.00 | 17- $\frac{11}{16}$ " | 30" | 762.00 | 76.20 |
| 500.00 | 50.00 | 19- $\frac{11}{16}$ " | 33" | 838.20 | 83.82 |
| 550.0 | 55.00 | 21- $\frac{5}{8}$ " | 36" | 914.40 | 91.44 |
| 600.0 | 60.00 | 23- $\frac{5}{8}$ " | 39" | 990.60 | 99.06 |
| 650.0 | 65.00 | 25- $\frac{9}{16}$ " | 42" | 1066.80 | 106.68 |

(continued)

TABLE 1.1 (Continued)

| From Metric to Imperial | | | From Imperial to Metric | | |
|--|--------|----------------------------|-------------------------|--------------------------------------|--------|
| mm | cm | Inches | Inches | mm | cm |
| 700.0 | 70.00 | 27- $\frac{9}{16}$ " | 45" | 1143.00 | 114.30 |
| 750.0 | 75.00 | 29- $\frac{1}{2}$ " | 48" | 1220.00 | 122.00 |
| 762.0 | 76.20 | 30" | 51" | 1295.40 | 129.54 |
| 800.0 | 80.00 | 31- $\frac{1}{2}$ " | 54" | 1371.60 | 137.16 |
| 850.0 | 85.00 | 33- $\frac{1}{2}$ " | 57" | 1447.80 | 144.78 |
| 900.0 | 90.00 | 35- $\frac{7}{16}$ " | 60" | 1524.00 | 152.40 |
| 915.0 | 91.50 | 36" | 72" | 1828.80 | 182.88 |
| 950.0 | 95.00 | 37- $\frac{3}{8}$ " | 84" | 2133.60 | 213.36 |
| 1000.0 | 100.00 | 39- $\frac{3}{8}$ " | 96" | 2438.40 | 243.84 |
| 1050.0 | 105.00 | 41- $\frac{5}{16}$ " | 108" | 2743.20 | 274.32 |
| 1100.0 | 110.00 | 43- $\frac{5}{16}$ " | 120" | 3048.00 | 304.80 |
| 1150.0 | 115.00 | 45- $\frac{1}{4}$ " | | | |
| 1200.0 | 120.00 | 47- $\frac{1}{4}$ " | | | |
| 1220.0 | 122.00 | 48" | | | |
| 1250.0 | 125.00 | 49- $\frac{3}{16}$ " | | | |
| 1300.0 | 130.00 | 51- $\frac{3}{16}$ " | | | |
| 1350.0 | 135.00 | 53- $\frac{1}{8}$ " | | | |
| 1400.0 | 140.00 | 55- $\frac{1}{8}$ " | | | |
| 1450.0 | 145.00 | 57- $\frac{1}{16}$ " | | | |
| 1500.0 | 150.00 | 59- $\frac{1}{16}$ " | | | |
| 1800.0 | 180.00 | 70- $\frac{7}{8}$ " | | | |
| 2130.0 | 213.00 | 83- $\frac{7}{8}$ " | | | |
| 2154.0 | 215.40 | 87- $\frac{1}{8}$ " | | | |
| 2410.0 | 241.00 | 94- $\frac{7}{8}$ " | | | |
| 2440.0 | 244.00 | 96- $\frac{1}{16}$ " | | | |
| Typical Imperial Cabinet Widths | | Imperial Conversion | | Typical Metric Cabinet Widths | |
| 6" | | 5- $\frac{7}{8}$ " | | 15 cm | |
| 9" | | 11- $\frac{3}{4}$ " | | 30 cm | |
| 12" | | 15- $\frac{3}{4}$ " | | 40 cm | |
| 15" | | 17- $\frac{3}{4}$ " | | 45 cm | |
| 18" | | 19- $\frac{3}{4}$ " | | 50 cm | |
| 21" | | 23- $\frac{5}{8}$ " | | 60 cm | |
| 24" | | 25- $\frac{5}{8}$ " | | 65 cm | |
| 27" | | 27- $\frac{5}{8}$ " | | 70 cm | |
| 30" | | 31- $\frac{1}{2}$ " | | 80 cm | |
| 33" | | 35- $\frac{1}{2}$ " | | 90 cm | |
| 36" | | 37- $\frac{3}{8}$ " | | 95 cm | |
| 39" | | 39- $\frac{1}{2}$ " | | 100 cm | |

(continued)

| | | |
|-----|------------------|--------|
| 42" | $41\frac{1}{2}"$ | 105 cm |
| 45" | $43\frac{1}{4}"$ | 110 cm |
| 48" | $45\frac{1}{4}"$ | 115 cm |
| 51" | $47\frac{1}{4}"$ | 120 cm |

Source: Table reprinted courtesy of Niagara Artcraft Woodwork Co. Ltd

TABLE 1.2 Typical Metric Cabinet Sizing

| Depths | | | |
|---|--------------------|--------------------------|--------------------|
| 35.0 cm + Door (2.5) | $14\frac{3}{4}"$ | | |
| 53.0 cm | $21\frac{15}{16}"$ | | |
| 60.0 cm | $24\frac{9}{16}"$ | | |
| Widths | | | |
| 15.0 cm | $5\frac{7}{8}"$ | 60.0 cm | $23\frac{5}{8}"$ |
| 25.0 cm | $9\frac{13}{16}"$ | 70.0 cm | $27\frac{9}{16}"$ |
| 30.0 cm | $11\frac{13}{16}"$ | 76.2 cm | 30" |
| 35.0 cm | $13\frac{3}{4}"$ | 80.0 cm | $31\frac{1}{2}"$ |
| 40.0 cm | $15\frac{3}{4}"$ | 85.0 cm | $33\frac{1}{2}"$ |
| 45.0 cm | $17\frac{11}{16}"$ | 90.0 cm | $35\frac{7}{16}"$ |
| 50.0 cm | $19\frac{11}{16}"$ | 91.5 cm | 36" |
| 55.0 cm | 21 | $5\frac{5}{8}"$ 100.0 cm | $39\frac{3}{8}"$ |
| Heights (Including Subbase/Toe Height/Leg Dimensions— 15 cm = $5\frac{7}{8}"$) | | | |
| 27.2 cm | $10\frac{11}{16}"$ | 104.0 cm | $40\frac{15}{16}"$ |
| 40.0 cm | $15\frac{3}{4}"$ | 118.4 cm | $46\frac{5}{8}"$ |
| 49.6 cm | $19\frac{1}{2}"$ | 134.4 cm | $52\frac{15}{16}"$ |
| 65.6 cm | $25\frac{3}{16}"$ | 144.0 cm | $56\frac{11}{16}"$ |
| 78.4 cm | $30\frac{7}{8}"$ | 175.0 cm | $68\frac{7}{8}"$ |
| 87.0 cm | $34\frac{1}{4}"$ | 215.4 cm | $84\frac{13}{16}"$ |
| 94.4 cm | $37\frac{13}{16}"$ | 231.4 cm | $91\frac{1}{8}"$ |
| | | 241.0 cm | $94\frac{7}{8}"$ |

Source: Table reprinted courtesy of Niagara Artcraft Woodwork Co. Ltd

As you consider representing a cabinet line, make sure you find out how the cabinet is sized: Are the cabinets sized on an imperial system, are they sized in a metric system, or are they a hybrid of the two? This is important, as there may be slight differences in cabinet case sizing that will affect the cabinet's fit with adjacent appliances and other pieces of equipment.

Mathematical Conversions

Here are the formulas for converting common measurements from one measurement system to the other:

- To convert inches to centimeters, multiply the inches by 2.54; for example, $23\frac{5}{8}$ inches (23.63 inches) $\times 2.54 = 60$ cm
- To convert centimeters to inches, divide the centimeters by 2.54; for example, 60 cm $\div 2.54 = 23.63$ inches ($23\frac{5}{8}$ inches)

KITCHEN CABINETS DIMENSIONS IN INCHES

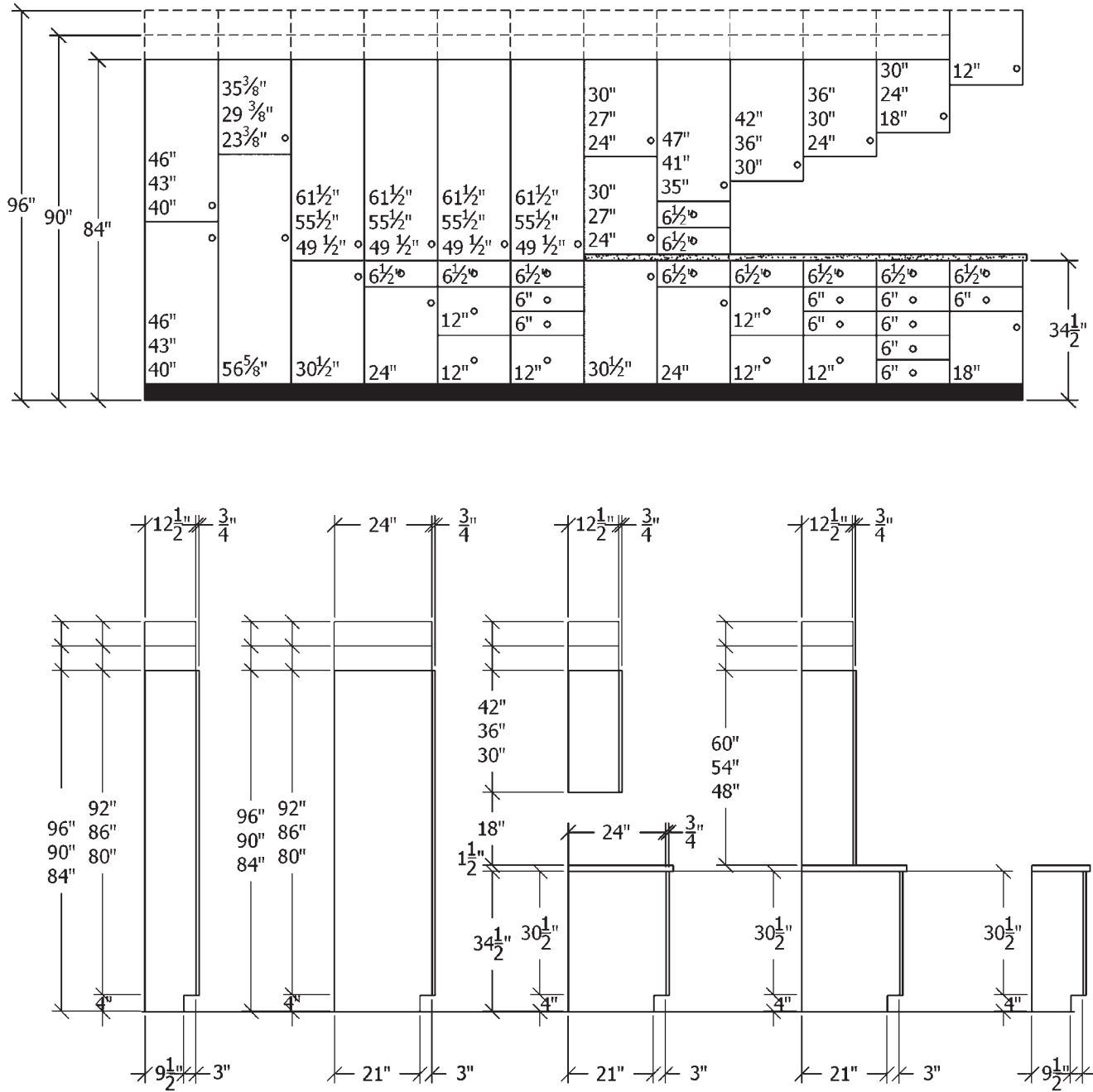
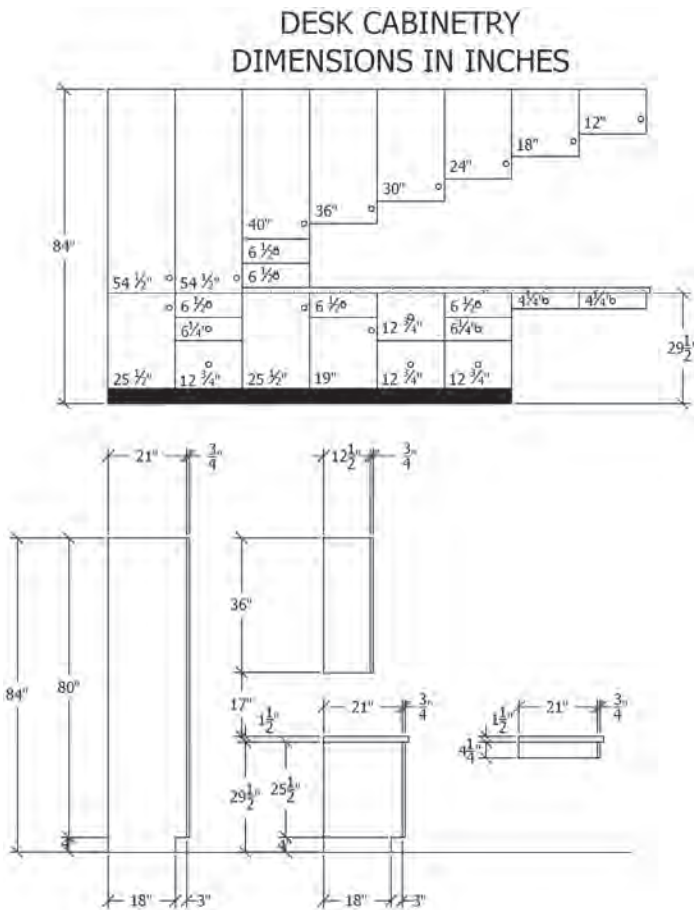
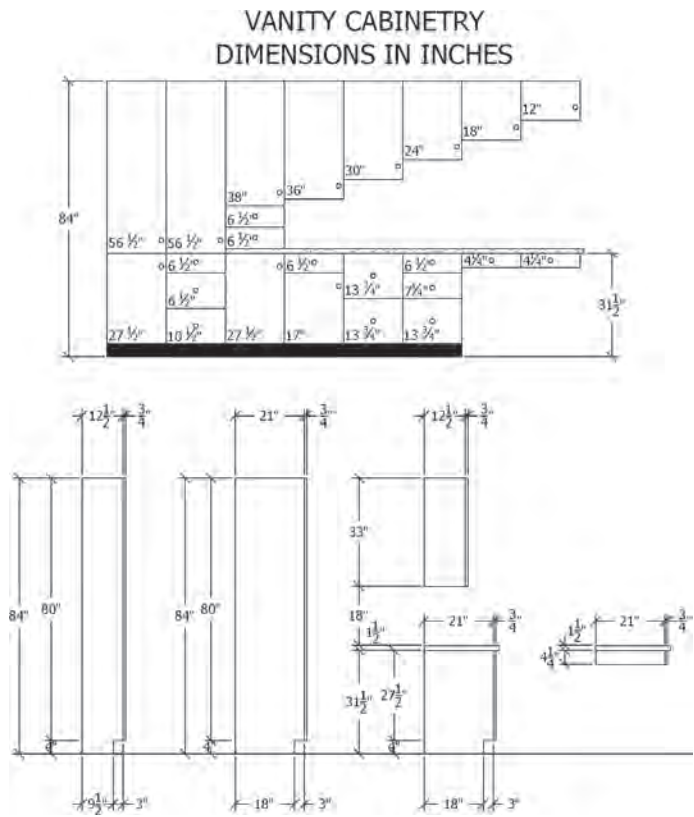

FIGURE 1.7 Typical imperial cabinet dimensions.

- To convert inches to millimeters, multiply the inches by 25.39; for example, $23\frac{5}{8}$ inches (23.63 inches) $\times 25.39 = 599.96$ cm
- To convert millimeters to inches, divide the centimeters by 25.39; for example, $599.96 \text{ cm} \div 25.39 = 23.63$ inches ($23\frac{5}{8}$ inches)

See Figure 1.7 for typical cabinetry dimensions in inches, and Figure 1.8 for cabinetry dimensions in metric.

FIGURE 1.7 (Continued)



KITCHEN CABINETS DIMENSIONS IN METRIC

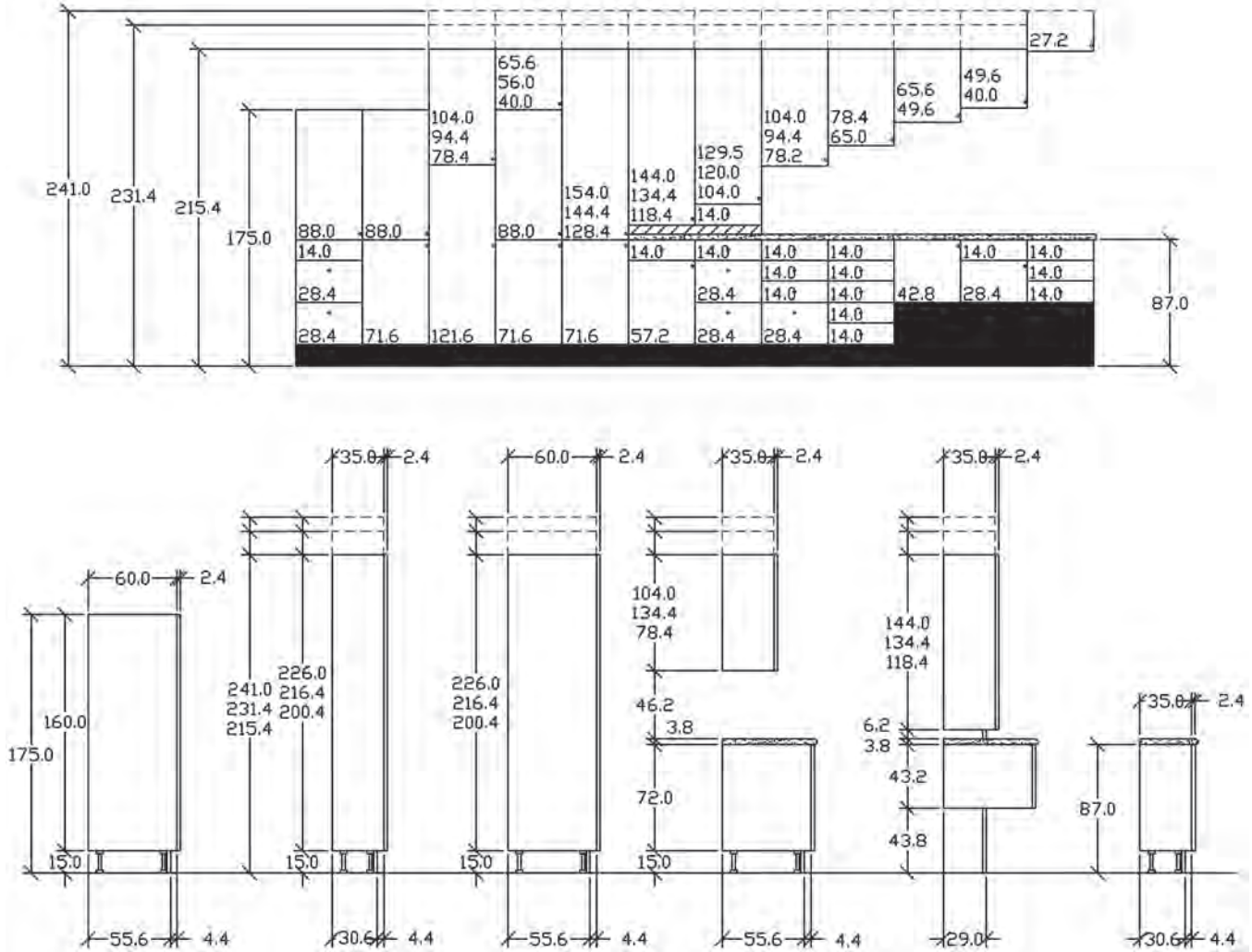

FIGURE 1.8 Typical metric cabinet dimensions.

CABINET MANUFACTURING SYSTEMS

As you consider cabinet options, one of the first decisions you must make is whether you will represent a cabinet featuring frame construction or one featuring frameless construction. Your product offering may be manufactured in North America or may be imported from another part of the world.

Cabinet Joinery Methods

Cabinet joinery methods can include all of the details shown in Figure 1.9. In nearly all cases, the joints are held together with staples or brads to allow glue time to cure. It is glue that locks the joints. Rabbet and dado cuts are used in case construction. Dovetail joints and dowels provide more drawer strength.

FIGURE 1.8 (Continued)

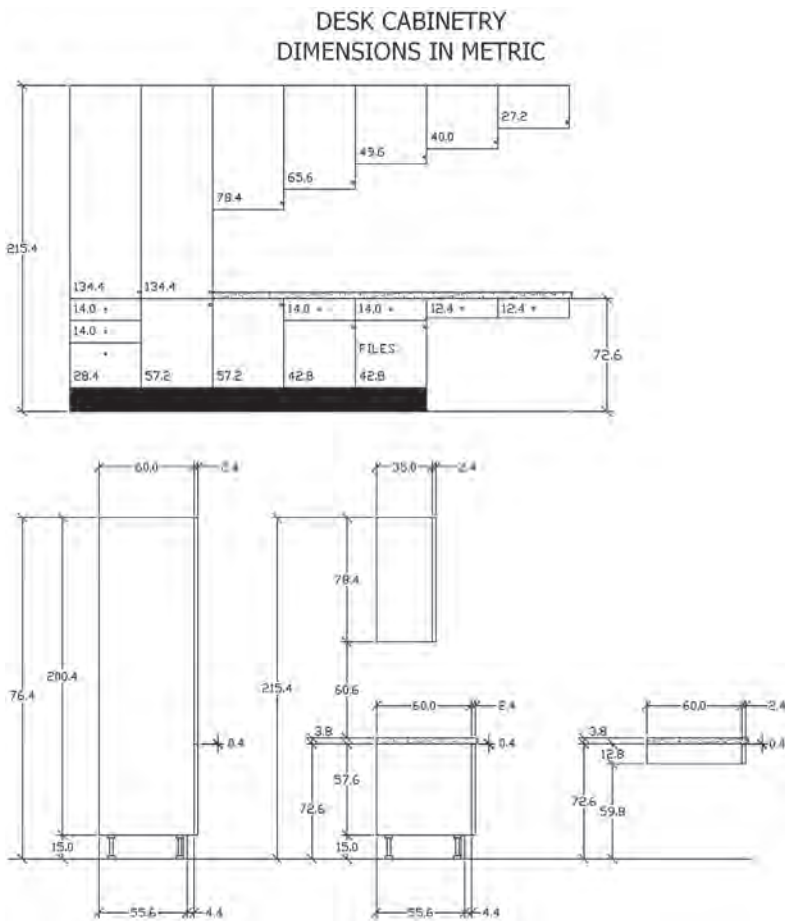
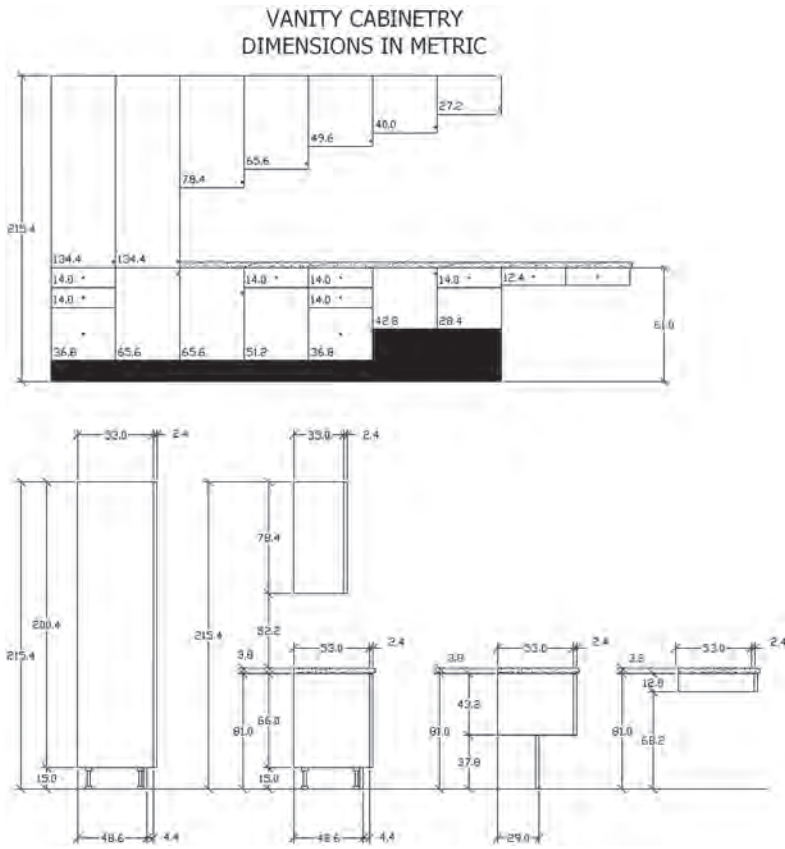
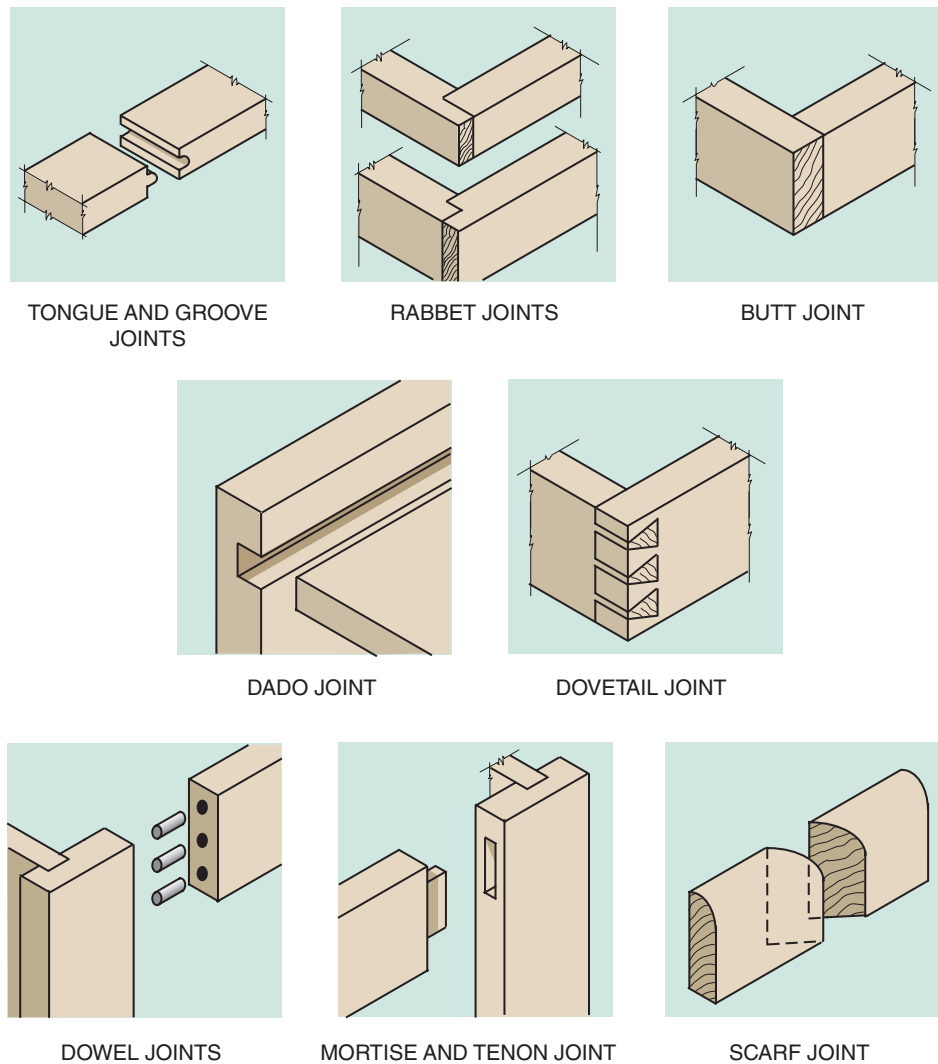

FIGURE 1.9 Cabinet joinery methods

Definitions

- **Dowel:** A short, round wooden stick with ends cut flat. In cabinet construction, dowels are used chiefly to reinforce corners.
- **Lap Joint:** A joint made by overlapping two ends or edges and fastening them together.
- **Mortise-and-tenon:** A slot cut into a board, plank, or timber, usually edgewise. The mortise receives a projecting part, or tenon, of another board, plank, or timber to form a joint. Many years ago, mortise-and-tenon joints were used in house building. Today, they are used mainly in assembling cabinets.
- **Mullion/muntin:** A vertical post or other upright that divides a window or other opening into two or more panes. Sometimes only ornamental.
- **Rail:** A cross member of a panel door or a frame cabinet face.
- **Stiles:** Vertical flanking members on a panel door or a frame cabinet face to which the horizontal top and bottom rails are secured.



Frame Construction

In frame cabinet construction, component parts make up the sides, back, top, and bottom of the cabinet (see Figures 1.10 and 1.11). These parts are then joined together and attached to the face frame, which is the primary support for the cabinet. Doors and drawers are then fit in one of three ways: flush with the frame (*inset*), partially overlaying the frame ($\frac{1}{4}$ inch *overlap or lip*), or completely overlaying the frame.

Frame cabinets are the easiest of the three systems to install because the clearance tolerances are more generous than those in inset or full overlay cabinetry, and may offer extended stiles to facilitate scribing on the job site. However, this method of construction has less interior storage space because the interior size of drawers or rollout accessories is smaller than the overall width of the cabinet.

- $1\frac{1}{4}$ to $1\frac{1}{2}$ -inch front frames are usually made of hardwood, $\frac{1}{2}$ inch to $\frac{3}{4}$ inches thick. Some cabinet manufacturers offer 1-inch-thick framing. Rails, stiles, and mullions are doweled (or mortise-and-tenon) as well as glued and stapled for rigidity. Lap joints and screws are also used.
- End panels typically consist of $\frac{1}{4}$ -inch to $\frac{3}{4}$ -inch plywood, composite or engineered board that is dadoed into the back of the stiles and then glued, stapled or nailed in place. They are secured square in each corner with a plastic, metal, or fall-off scrap material gusset. Some manufacturers provide a full top to increase stability.

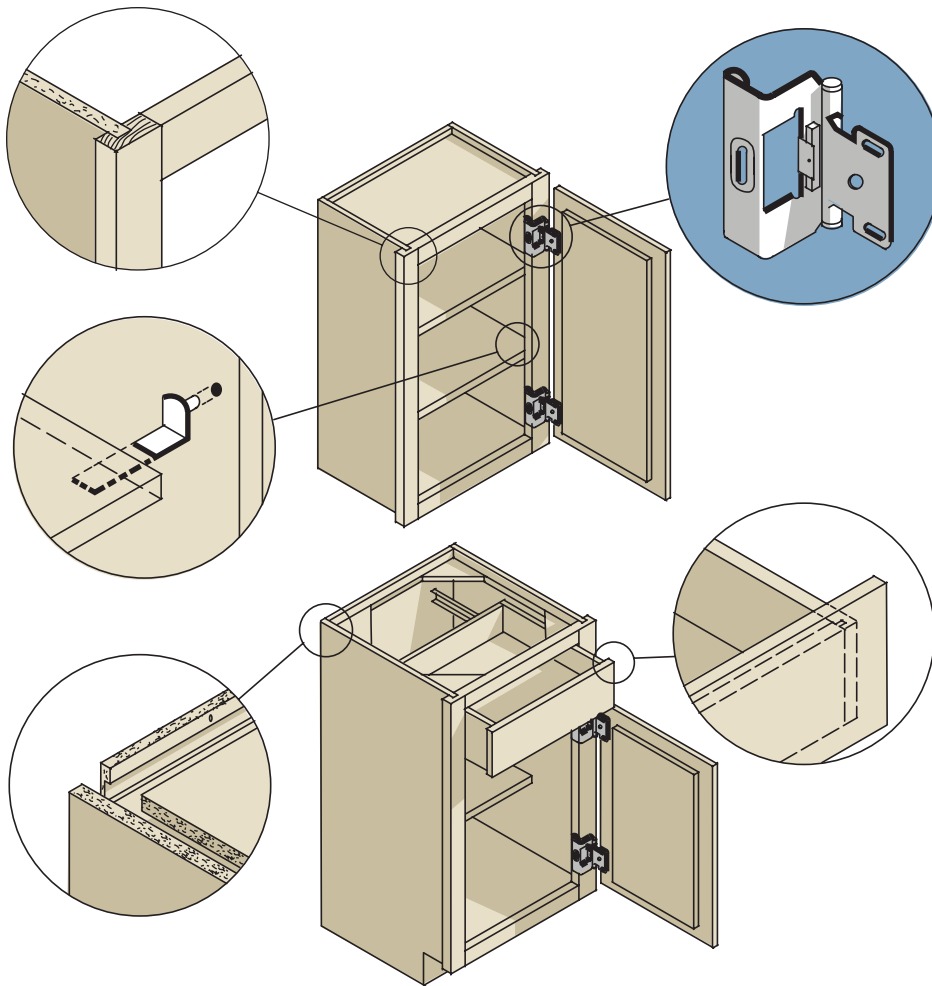

FIGURE 1.10 Typical framed cabinet component parts. Framed cabinets are fitted together with various forms of wood joinery and without special hardware fittings. Door hinges attach to face frame and generally do not have multiple adjustments.

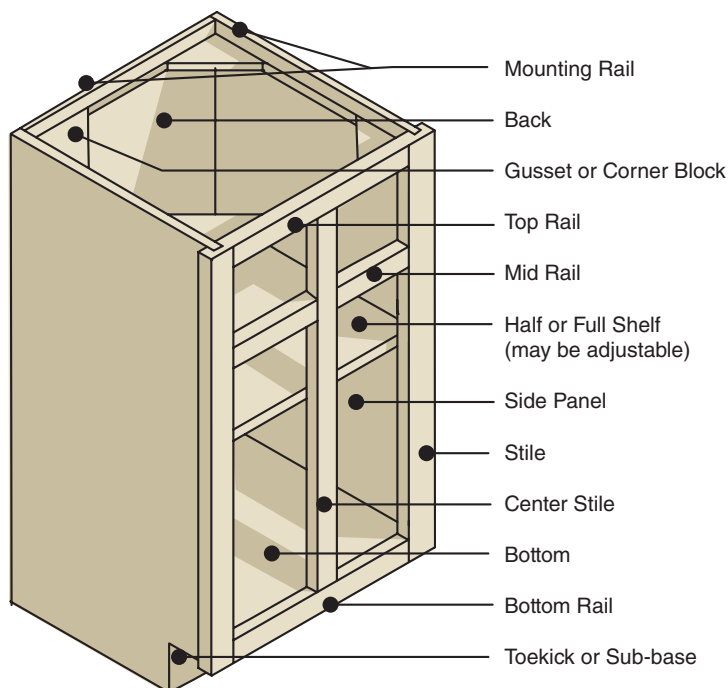

FIGURE 1.11 Typical framed cabinet construction details

- Backs are generally $\frac{1}{8}$ -inch hardboard to $\frac{3}{4}$ -inch plywood or composite board.
- Bottoms and tops are 3- or 5-ply plywood or composite board. They are $\frac{1}{4}$ inch to $\frac{1}{2}$ inch thick and are dadoed into the sides of the cabinet.
- Shelves are lumber, plywood, or particleboard, $\frac{1}{2}$ inch to $\frac{3}{4}$ inch in specification, with square or rounded front edges. Plywood and composite board shelves are generally banded with hardwood or with a wood-grained edging material.

Frameless Construction

Frameless construction is the second major category of case construction. While both types of cabinetry are built in the United States, the majority of cabinetry built in Canada and imported from other international manufacturers is frameless. With this method of construction, these case parts form a box that does not need a front frame for stability or squareness. Doors and drawers cover the entire face of the cabinet (see Figures 1.12 and 1.13).

- $\frac{5}{8}$ -inch to $\frac{3}{4}$ -inch composite board, plywood, or engineered wood sides are connected to the back, top, and bottom with either a mechanical fastening system or a dowel method of construction.
- Backs are $\frac{1}{4}$ inch, $\frac{1}{2}$ inch, or $\frac{3}{4}$ inch.
- Tops are $\frac{1}{2}$ inch or $\frac{3}{4}$ inch.
- The sides are drilled for adjustable shelf clip holes or dadoed for fixed shelves.
- The doors are bored for adjustable, fully concealed, self-closing hinges.
- Generally all exposed edges are banded.

The major advantages of frameless construction are total accessibility to case interior and the clean, simple design statement made by the finished product. Additional planning expertise is required to ensure proper clearance between these full overlay doors/drawer heads and adjacent cabinets and appliances of the plan. The fit and finish of the cabinets to adjacent walls and the overhead ceiling also requires knowledge about the use of scribe trim molding and fillers.

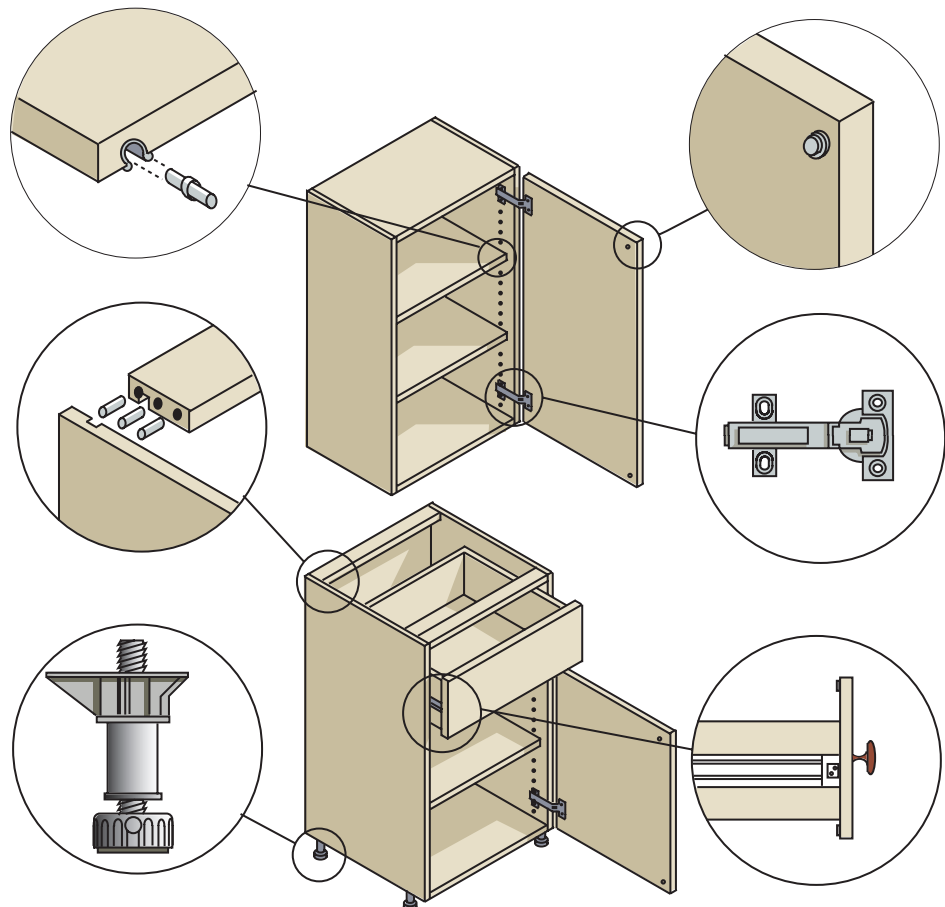

FIGURE 1.12 Typical frameless cabinet component parts. Typical frameless cabinet construction is oriented to hardware and production. Pins and dowels, which might be wood or metal, are made to fit specific holes, all of which are drilled when the cabinet is manufactured. Hinges are completely concealed. Leveling legs may be used instead of an attached subbase.

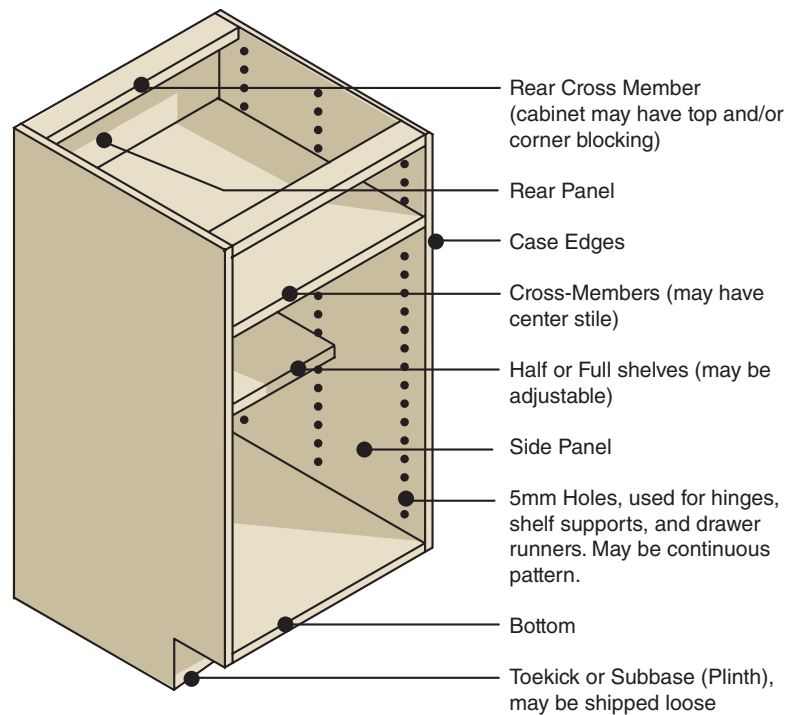

FIGURE 1.13 Typical frameless cabinet construction details

Hybrid Frame/Face Frame Construction

Some manufacturers have created a hybrid cabinet construction system allowing them to utilize the engineering method of frameless construction for the case while creating the look of handcrafted joinery by adding a nonfunctional face frame to the front exterior of the cabinet.

In this method of construction, the width of the face frame (less the thickness of the side material) extends beyond the case side, resulting in a void space between each cabinet.

CABINET INTERIOR STORAGE SYSTEMS

Drawer/Rollout Configurations

All kitchens include a combination of cabinetry featuring fixed or adjustable shelving combined with single drawers above doors or banks of drawers, which may be in two-, three- or four-drawer configurations. Most manufacturers also offer some type of roll-out shelf system, which is actually a drawer mounted on top of a shelf or to the inside vertical partitions of the cabinet.

The advantage of drawer storage or rollout storage is clear: the items stored within the cabinetry become much easier to see, retrieve, and replace.

Four major types of drawer construction systems are used within the cabinetry industry:

- 1. Butt joint drawer system.** A butt joint drawer system secures the individual pieces of component parts together without an interlocking joint. Once thought to be a less durable form of construction, today's butt joint drawers, which utilize better adhesives and capture the bottom of the drawer in channels machined into drawer sides, front, and back, are as durable as a classic dovetail joint.
- 2. Dovetail drawer system.** A four-sided wood drawer box engineered with dovetail joints is offered by many manufacturers. A hallmark of craftsmanship in fine woodworking for centuries, the dovetail joint is considered by many to be the preferred method of joining two pieces of wood together. The name comes from the protruding portion of the joint, reminding one of a dove's tail. Because of the interlocking nature of this joint, it readily accommodates the natural expansion and contraction of the wood over the life of the drawer without affecting the structural integrity of the joint.
- 3. Metal drawer system.** Drawer slide manufacturers offer a totally integrated drawer system featuring a stainless steel, aluminum extruded, or other metal-type three-side

drawer system, which typically has a shaped profile top edge and bottom edge. The drawer bottom repeats the material selected for the case interior. These three-sided drawer component systems then connect directly to the drawer head and usually incorporate the drawer guide system into their construction. The drawer system may feature a solid drawer side or may allow a design statement to be added: Wood, glass, leather, or marble can be incorporated into the sides or face of some drawer systems.

- 4. Miter-framed drawer system.** A four-sided miter-framed low-pressure melamine drawer system or a boxed melamine drawer system is considered an entry-level drawer. This type of interior normally matches the case interior. Miter-framed drawer systems score the core material of the drawer; then the sections of the drawer are folded together to form the box.

Planning Considerations

A key element of the cabinet specifications is to define the specific storage components planned behind the door and drawer fronts. As noted in the *Kitchen Planning* volume of the NKBA Professional Resource Library, kitchen planning has been studied for the last 150 years. Recently, a major manufacturer (Blum Inc., www.blum.com/us) continued this endeavor by identifying specific items maintained in a kitchen and studying the path of the cook as he or she worked in the space. This information is helpful when considering the options for an interior storage system and placing these items within cabinet interiors (see Figure 1.14).

The storage requirement for a specific kitchen is based on the client's collection of point-of-use countertop appliances, shopping habits, size of household, and lifestyle. Based on the Blum survey, on average, 360 individual activities occur each day in the kitchen. These activities include simple motions, such as removing a vegetable peeler from a drawer, peeling at the table and taking the peelings to the trash container, and finding a pot and lid to cook the potato. Over the course of 20 years, this amounts to approximately 2.6 million activities in the kitchen. Since items need to be accessed during many of these activities, placing them in their proper kitchen zone so they can be retrieved as quickly and easily as possible will help reduce work time and the physical effort required to complete kitchen tasks.

Home economists and other motion specialists have undertaken this type of work simplification study over the years. An overview of the academic research was first published in the *Beyond the Basics . . . Advanced Kitchen Design* textbook that was used for NKBA advanced training programs.

Back to the Basics: Become Familiar with the Concept of Motion Economy

To add value to your solution and the cabinets you specify, study or remember the long-standing time management principles as they relate to motion economy. Simply put, saving motion during any activity not only means saving the human worker energy; it also means saving the person's time. Time is one of our most valuable commodities today; indeed, for many people, it is priceless.

Work Simplification Principles Revisited

Be cognizant of the value of energy management. Each person has a finite amount of energy, depending on physical heritage, age, and general health. You can minimize the effort needed to cook in the new room if you are familiar with the research and ask the right questions when you first interview your client.

As you interview your client and review the space under development, remember that household tasks require several types and combinations of efforts:

- Mental effort to think through the task
- Visual effort as the eye directs the movements of the body
- Manual effort as the person reaches, lifts, carries, pulls, and pushes objects as part of the task
- Upper body strength and mobility required for bending, leaning, rising, turning, and stooping
- Pedal effort to walk, move, and stand



FIGURE 1.14 A collection of items stored in a kitchen
 Courtesy of Blum Inc.

Designers can help their clients minimize the motion needed by employing four basic techniques.

1. **Eliminate unnecessary work.** By incorporating interior storage aids, no energy is needed to search, remove, and/or replace objects in the cabinet interior.
2. **Combine operations of elements.** Thinking through the sequences family members follow when using the kitchen will lead to a plan based on a logical, fluid path for the primary cook to follow.
3. **Change the sequence of an operation.** By carefully monitoring the food/equipment flow, storage/preparation/cook/usage steps can be minimized.
4. **Simplify the necessary operations.** Any plan enhancement that can simplify the operation at hand will save energy. Locating non-cooking-related activities along the perimeter of the cook's central workstations simplifies the cooking operation.

How high can the average cook reach? How much counter space does the cook use?

It is also useful to be familiar with research projects that identify functional limits of reach, and the typical cook's *work curve*.

- **Functional limits.** Cornell University studied shoulder-to-grasping, fingertip reach of individuals 5 foot 3 inches to 5 foot 7 inches, and established 79.6 inch as the highest

comfortable overhead reach for these cooks. When the reach was over a 25-inch-deep counter surface, the top shelf height was lowered to 69 inches. In the same manner, 48 inches was set as the comfortable side-to-side reach and 24 inches off the floor was set as the lowest point or fingertip level from the floor (see Figure 1.15). This is excellent



FIGURE 1.15 Accessing lower base cabinet shelving or overhead shelving requires more energy than reaching storage levels closer to the countertop level.

Courtesy of Blum Inc.



FIGURE 1.16 Tall cabinet storage systems provide flexibility.
Courtesy of Blum Inc.

information to use when thinking about uninterrupted counter space or how and where wall cabinets or other types of above-countertop storage units might be located (see Figure 1.16).

- **Work curve.** The same study determined the normal work curve (or elbow circle) had a maximum depth of 16 inches. This is why the average countertop height, 25 inches, provides plenty of room for spreading out supplies or stacking plates in front of the user. This is also a very important measurement when designers are considering new and unique backsplash storage system solutions (see Figure 1.17).



FIGURE 1.17 Using countertop space
Courtesy of Blum Inc.

Storage Guidelines

When planning a kitchen, the designer must consider the homemaker's available time and energy level. These guiding principles should be followed: Build the cabinets to fit the cook, build the shelves to fit the supplies, and build the kitchen to fit the family.

Storage guidelines are based on three basic tenets:

1. Store supplies at their center of use.
2. Ensure all supplies are clearly visible.
3. Ensure all supplies are easily accessible.

To accomplish this, storage specialists suggest:

- Store items at the first or last place of use.
- Store items in multiple locations if used for different tasks.
- Store items that are used together in the same location.
- Store items so they are easy to locate at a glance.
- Store or group together like articles.
- Store frequently used items within easy reach. (Based on research, “easy reach” normally is defined as between eye level and hip level at the front of the cabinet’s shelf, or placed anywhere within the confines of a pullout or rollout shelf.)
- Store items so they are easy to grasp at point of storage.
- Store items so they are easily removed when removing other items first.
- Place heavy equipment at or near floor level.
- Utilize all space for utmost efficiency. Share these principles with your clients before you complete the storage system layout and then remind them about these basic principles, which will guide them in organizing the kitchen (or bath) cabinetry after the installation is complete.

Help clients declutter by encouraging them to use all shelf/drawer space for utmost efficiency by prioritizing items according to frequency of use. The most frequently used items should get the best location. In addition, if something is not used, an important question to ask is: Should everything be returned to the new room? A *one-year test* is a good rule of thumb: If an item has not been used in one year, perhaps it should be repurposed or given away rather than stored.

Planning the Interior Cabinet System Based on Zones within the Kitchen

The new studies conducted by the Blum organization continue to focus on the need for designers to create asdynamic space, one that supports the cook’s efforts by minimizing his or her physical exertion while producing a meal or completing other activities in a residential kitchen.

The key components of the dynamic space concept are to:

- Reduce the stress placed on the body, thus making it easier to work in.
- Shorten the distance traveled and time spent through proper zone planning (see Figure 1.18).



FIGURE 1.18 The cook’s work path
Courtesy of Blum Inc.



FIGURE 1.19 The kitchen divided into zones of activity
 Courtesy of Blum Inc.

The storage guidelines referenced earlier discussed placement of frequently used items. The Blum survey gives us information that is more specific (see Figure 1.19.).

Research conducted by the Blum organization resulted in an observation that there were more than 100 zone changes per day in the kitchen of an average four-person household (an average based on the variety of household demographics and cooking habits). This survey is briefly referenced in the *Kitchen Planning* volume of the NKBA Professional Resource Library.

Because this information is an excellent foundation for specifying a cabinet interior storage system, we have included the details of this study.

On an average daily basis:

- People make 30 trips to and from some type of seated/dining/gathering area.
- Fifty separate activities are performed within the individual zone.
- Appliances are used 30 times.
- Doors and drawers opened and closed over 80 times.

Blum made comparisons of traditional planned kitchens to those planned in accordance with the *dynamic space* concept using the string study method. To identify a work pattern, string is attached to the worker's body. At the end of the day, the length of string is measured to establish the distance covered. After a typical day in a kitchen that had been carefully zoned based on anticipated activity, the total footsteps were reduced by as much as 25 percent, saving distance traveled, and time spent in the kitchen.

Zones

- **Consumables zone.** Items in the consumables zone consist of anything that is eaten and needs to be replenished. The refrigerator is a part of this zone since both perishable and nonperishable items are stored here.
- **Nonconsumables zone.** The nonconsumable zone contains items such as dishes, cutlery, glassware, plastic containers and their lids, jugs and pitchers, and a few small appliances.
- **Cleaning zone.** Items found in the cleaning zone are centered on the sink. Cleaning agents, sponges, dish detergents, and cleaning utensils are stored here. Space should also be planning for the trash can and recycling containers.
- **Preparation zone.** The preparation zone holds items used during meal preparation. The storage items in this zone require an assortment of drawer depths. Shallow spaces are needed for utensils, while deeper drawers are required for appliances, mixing bowls, pots and pans, and enclosed containers storing food-related ingredients or products.
- **Cooking zone.** The items in the cooking zone are needed close at hand. Centered on the cooktop, oven, and microwave, the area requires the storage of oven mitts to move pots, pans, baking dishes, and cookie sheets from the heat.

Based on this information, the cabinets themselves and their interior storage systems should be organized following these four key points:

1. Consider cabinet sizes based on the five kitchen zones identified.
2. Choose cabinets with ergonomic benefits to support the activities associated in each of these zones.
3. Create optimal access into the cabinet specified.
4. Organize the contents of the cabinet.

Special-Purpose Component Storage Systems

Both cabinet manufacturers and accessory manufacturers also offer special-purpose interior accessory programs that feature formed plastic, coated steel, or stainless steel units. For example, a recycling center may include two large plastic trash receptacles that slip into openings in a rollout shelf or sit in a rollout attached to the drawer. Spice shelves and canned-good storage systems may be available in wire or chrome offerings. Corner swing-out shelves may form plastic half-moon sections or a system designed from wire.

In addition to plastic, coated-wire, and chrome-wire systems, many custom manufacturers offer a full complement of wood accessory component systems, which maximizes the customization of a cabinet order specifically designed for the client.

All types of drawer systems have coordinating storage inserts to separate and conveniently store cutlery, serving pieces, silverware, spices, and knives. These storage systems may be

formed plastic, wire, or custom-made wood, sized to the specific drawer being constructed. The inserts may be designed as compartments storing a quantity of items or may be individually sized and shaped for specific kitchen utensils and cooking paraphernalia.

Figures 1.20, 1.21, and 1.22 present a series of images from various respected manufacturers of storage systems demonstrating the type of interior storage components designed for



FIGURE 1.20 Drawers can be organized with a variety of interior component parts.
Courtesy of Blum Inc.





FIGURE 1.21 Special-purpose cabinets are available to create a recycling center, use a narrow width of wall space, and organize the area underneath the kitchen sink.

Courtesy of Häfele America





FIGURE 1.21 (Continued)



FIGURE 1.22 Specially engineered base cabinet storage systems are available as pullout and swing-out systems for all kitchen centers.
Courtesy of Rev-A-Shelf



FIGURE 1.22 (Continued)



FIGURE 1.22 (Continued)

inclusion in a variety of home storage areas. We go beyond the kitchen and bathroom, and include entertainment area, utility room, home office, and dressing room storage systems.

CABINET MECHANICAL/FUNCTIONAL HARDWARE

Cabinet Door Hinging: Frame Cabinetry

Traditional frame cabinets use a surface-mounted hinge that attaches to the inside edge of the frame and the outside edge of the door. The relationship of the door to the frame determines the type of hinging specified.

Square edge. For inset door styling, hinges have an exposed barrel with or without decorative finials at the top and bottom. Some hinge manufacturers offer a custom-designed European-style hinge, which fits on the inside of the framed case and does not have any exposed mechanical elements on the exterior. This type of hinge often is called a *concealed inset hinge*.

Profile (shaped) edge. For framed cabinetry offering an overlay door configuration (the door may lie completely against the face of the cabinet or be notched around the cabinet opening), similar hinges are designed that are shaped to fit the door profile. These hinges come in a variety of quality levels and a multitude of finishes.

Cabinet Door Hinging: Frameless Cabinetry

Frameless cabinetry uses totally concealed hinges on the inside of the cabinet: One hinge end is inserted in the door back and the other into the side of the cabinet. Most of these hinges are *demountable*, which means they easily snap on and off during installation. Typically they are adjustable in three directions (up and down, in and out, and left and right), allowing the installer to maintain correct reveal dimensions between the doors and drawers, critical in this type of cabinetry.

Hinges designed for full overlay cabinetry may be considered *low profile*, which means they do not protrude into the cabinet space more than 1 inch (2.50 cm) and typically are 110-, 120-, or 125-degree openings. The larger the opening, the easier it is to access the interior of the cabinet. Some oversize hinges are available, which allow the door to open a full 170 degrees. The client and designer need to compare and evaluate the advantages of the increased opening against the disadvantages with the overall size of the hinge.

Today, hinges are considered *self-closing* or *soft closing*. This means the frameless cabinetry door hinge slows its closing speed as it nears the cabinet face and then gently closes itself. This soft closing system reduces noise and wear and tear on the hinges in an actively used room.

Cabinet Door Hinging: Special Purpose

Some door opening hardware for frameless cabinetry is available with electronically controlled mechanisms that allow the door to open with a simple tap.

Hinges Designed for Thicker Doors

All of the hinges described above are designed for $\frac{3}{4}$ -inch (often called $\frac{4}{4}$) door thicknesses. Some manufacturers offer full 1-inch-thick doors (called $\frac{5}{4}$ doors), which require special hinging considerations.

Oversize Hinges

Although frame cabinetry hinge sizing is very similar across brands, some manufacturers offer oversize hinges that add greatly to the aesthetics of old world rooms or very large spaces.

Sliding/Pocket/Bifold/TILT-up Hinging

In addition to the two cabinet hinging systems just described, cabinet manufacturers offer many special-purpose hinging systems. These include retractable door systems to conceal televisions, home office equipment, or a microwave. Doors tilt up or swing down. Several systems allow doors to slide left to right as well.



FIGURE 1.23 Wall cabinet with sliding door hardware system
 Courtesy of Häfele America

Many innovations in cabinetry hardware allow doors to slide in front of one another (called a *sliding door*) (see Figure 1.23) or move to the left or right, and then make a right angle turn into a *pocket* (called a *pocket door*). These two types of hinging systems are often used in all types of cabinets: base cabinets, wall cabinets, and tall cabinets.

Special-purpose wall cabinet hardware is available that allows a door to swing up above eye level. Other specialty hinges are designed for cabinet doors that fold in the middle and are then pushed up providing full access to the cabinet interior (see Figure 1.24). These types of hinging apparatus are most common in frameless cabinetry. They require sophisticated side-mounted hardware components, which may intrude on some of the interior cabinet storage. They can be controlled manually or electronically.

New electronically operated cabinet door systems are being introduced in both the European and North American markets. These doors may be a shutter configuration that extends to the counter in a closed position that, when activated by a remote control, are stacked at the top of the cabinet; they may be doors that open and slide in front of one another; or, they are available in doors that hinge up. Last, there are upper cabinet shelf hardware systems that allow the entire contents of the wall cabinet to be pulled down to countertop height (see Figure 1.25). Additionally, there is hardware that allows a countertop or cabinet to be raised or lowered in height.

New innovations continue to be launched in this special-purpose hardware category (see Figure 1.26). Designers wisely stay in close communication with their cabinet, new product development, marketing, or engineering counterparts to learn what the next innovation may be.

Interior Shelf Adjustability

Usually cabinet systems, whether frame or frameless, offer full-depth adjustable shelves in wall cabinets. Base cabinet shelves may be one-half the depth of the cabinet, three-quarters the depth of the cabinet, or full depth. Some custom manufacturers make these shelves adjustable as well; most stock and semi-custom producers fix the lower shelf in place.

What the shelf is made from, what the banding material is, and whether all four edges are banded impact whether the homeowner can turn the shelf if an edge is damaged during use. The core material also dramatically affects the deflection rate of the shelf and, therefore, how wide a cabinet can be without a center stile. To keep the box rigid, many manufacturers will not build a cabinet wider than 30 inches without a center stile. Other manufacturers have engineered their cases to allow the designer to specify a cabinet as wide as 42 to 48 inches with no center stile and with a shelf engineered so it can be stocked with evenly distributed weight without noticeable deflection.



FIGURE 1.24 Examples of wall cabinets with fold-up or swing-up door hardware
Courtesy of Blum Inc.



FIGURE 1.25 A special cabinet for a kitchen wellness center
 Courtesy of Rev-A-Shelf

The maximum overall shelf length and weight limits are also determined by the shelf pin system selected to provide adjustability. Typical mechanical systems are:

- A metal strip, surface mounted or routed into the side of cabinetry, with locking shelf supports.
- A series of holes running the entire height of the cabinet, or clustered around typical shelf locations.
- 2 mm or 5 mm diameter holes are typical. A metal or plastic pin recesses into the hole. The shelf might simply sit atop this pin, or the pin might be designed to lock the shelf in place. This second approach is considered the best choice because it eliminates the possibility of shelves tipping.
- Shelf pins used for glass shelves are of the same design, with the addition of a small bumper to ensure the glass does not slip or slide out of place.

Drawer Guide (Slide) Systems

Other than small decorative antique drawers, which have a wood slide system, all manufacturers in the kitchen industry today offer well-engineered drawer guide systems. (Some manufacturers call them *slide* systems.)

Side-Mounted Systems

Epoxy-coated, side-mounted guide systems that have a slant at the back of the track so that the drawer guide self-closes once it is within 1 inch or so of the cabinet face are available in entry-level products. The guides allow the drawer to extend three-quarters of the way into the kitchen; a full-extension configuration can be specified.

Some heavy-duty side-mounted metal drawer guides are available for general-purpose use or for special-purpose applications, such as heavy double trash bins, file drawers, or other cabinetry that will carry extra weight.

A third type of side-mounted drawer guide system features a sophisticated rack-and-pinion system designed to carry a very large drawer that will be loaded with heavy cooking pots and pans.

Under-Mounted Systems

Under-mounted guide systems come in both *three-quarter extension* and *full extension*. These drawer guide systems are engineered to provide a self-closing or soft-close feature, be



FIGURE 1.26 Oversized wall or tall cabinet doors provide total accessibility to interior cabinet shelving.
Courtesy of Artcraft Kitchens

easy to remove and replace by users over the years, and include some type of adjustability so the drawer head can be slightly realigned against the case. These drawer guide systems also have a high load-bearing capacity and enclose the track system to simplify maintenance over the life of the drawer guide.

Special Purpose

A new opening feature is available for frameless cabinet systems that allows for a gentle opening, regardless of the drawer's width or weight factor. These drawers open automatically with just a touch of the drawer front or with a light pull on the handle. This system is based on an electrical drive that, once activated, opens the drawer for you.

Typically, modifications to the drawer system are not necessary when adding this electronic feature. It is important that an on/off switch is included, allowing the homeowner to deactivate the electronically controlled drawer opening system and therefore save energy when not



FIGURE 1.26 (Continued)

in use. The drawer system remains functional, whether the power is on or off; with a pull of the handle, the drawer runs smoothly in a manual operation mode.

CABINET SIZES

Each manufacturer publishes a paper or electronic catalog of its product range. A general discussion of the most widely used cabinet sizes and types is presented next.

Kitchen Cabinetry Units

Base Units and Special-Purpose Base Units

Base cabinets, which are set on the floor, are 21 inches deep in many systems built internationally. Most North American cabinets are 24 inches deep, front to back, and $34\frac{1}{2}$ to $34\frac{3}{4}$ inches high including the subbase (which is also called the *toe kick* or *plinth*). This raised portion underneath the cabinet is generally 4 to $4\frac{1}{2}$ inches high in domestic cabinetry and 6 inches high in international cabinetry.

The common base cabinet has a single drawer over a single door that has either a half shelf or a full shelf in the middle and a full shelf at the bottom of the cabinet.

North American single-door base cabinets generally are available in 3-inch increments, starting with 9 inches, then going to 12, 15, 18, 21, and 24 inches. The 9-inch-wide cabinet generally will not have a drawer and may not be available in heavily detailed door styles. Double-door cabinets are usually available in widths from 24 to 48 inches; however, some manufacturers do not provide 39-inch- or 45-inch-wide units. Others stop the line at 42 inches wide.

International metric sizing is based on centimeters, with typical sizes being 10 cm, 15 cm, 20 cm, and so on.

Special-Purpose Base Cabinets

In addition to the standard base cabinet, special-purpose base cabinets are available for specific needs. The listing of typical cabinets at the end of this section discusses each one of these types of cabinets.

Generally, the categories of base cabinets you can choose from are:

- **Drawer cabinets.** A cabinet that features two, three, four, or five drawers. Two-drawer units frequently are used today to create a recycling unit. Three- and four-drawer units typically are seen near the primary sink for flatware and kitchen linen storage (see Figure 1.27). Wide, two- or three-drawer units often are used below a cooking surface to store pots, pans, lids, and utensils used at the cooking surface. Try to avoid drawer units smaller than 15 inches wide because the interior drawer space will be too small to be functional.
- **Corner cabinets.** A variety of corner cabinets are available:
 - Lazy Susan base cabinet:** Generally requires between 33 and 36 inches of space on each wall. A round shelf swings out into the room and past the door opening. The door may be bifold (see Figure 1.28) or actually may swing through the cabinet interior. The wider the door, the more functional the circular shelf.
 - Blind cabinet:** A cabinet that has a shelf, pullout, or swing-out apparatus to provide accessibility into the corner (see Figure 1.29). A blind cabinet generally requires 42 to 48 inches of wall space. Although available in 36 and 39 inches, avoid any unit less than 42 inches wide to ensure reasonable access.



FIGURE 1.27 Examples of drawer organizing systems

Courtesy of Häfele America



FIGURE 1.27 (Continued)

Pie-cut cabinet. A corner cabinet that requires 36 inches on each wall (much like a Lazy Susan) and features stationary shelving as opposed to a rotating shelf (see Figure 1.30). Maximum shelf space is provided. One type of pie-cut unit may be rounded with a curved door.

- **Recycling center.** Specialized cabinets that are designed to hold bins to facilitate the separation and recycling of refuse (see Figure 1.31).



FIGURE 1.28 Example of base cabinet or Lazy Susan system
 Courtesy of Wellborn Cabinet, Inc.



FIGURE 1.29 Corner cabinets with swing-out shelves
Courtesy of Wellborn Cabinet, Inc.



FIGURE 1.30 Decorative open corner pie-cut cabinet
Courtesy of Wellborn Cabinet, Inc.



FIGURE 1.31 Recycling center
Courtesy of Häfele America



FIGURE 1.32 Kitchen with special-purpose wall units: 42-inch-high wall cabinets extend to the ceiling, providing extra shelf space.

Design by Adel Visser, CKD, CBD, CID

- **Sink/cooktop cabinet.** Base cabinets with a voided top drawer or a tilt-down front that houses a plastic or stainless steel container. The tilt-down is designed to utilize the top-drawer space that would otherwise be lost once the cooktop or sink is installed. The drawer area can be replaced with a special cutout to receive a farmhouse sink or a front-controlled cooktop. These cabinets may be pulled away from the wall with decorative columns or turnings finishing each side, creating a focal point within the room. This type of cabinet configuration is called a *bump-out*.

Wall Units and Special-Purpose Wall Units

Wall cabinets that are fixed to the walls with screws generally are 12 inches deep. They come in a variety of heights ranging from 30, to 36, to 42 inches (see Figure 1.32). Some manufacturers offer sizes to 48 inches. The 30-inch-high wall units are designed to be installed in a room with 96-inch-high ceilings with an extended, flush, or recessed soffit (drop) above them. *Soffit* is an industry word identifying a boxed-in area above the cabinets. The proper construction term would be a *bulkhead*, made up of fascia (the front panel) and the soffit (the underside). However, it is typical in the industry to call the entire structure a soffit.

The 36-inch-high units are designed to be installed in a 96-inch-high room with a 6-inch trim connecting the cabinets to the ceiling. These units also are used in a 108-inch-high ceiling to provide better balance between the cabinet spacing and the architectural envelope of the room. The 42-inch-high wall units are designed to extend all the way up to a ceiling in a



FIGURE 1.33 A wall cabinet extends to the countertop, providing an appliance storage area.

Courtesy of Wellborn Cabinet, Inc.

96-inch-high room or to be used with an extended, flush, or recessed soffit in 108- or 120-inch-high ceilings.

For use above microwave ovens, hoods, refrigerators, or other tall obstructions, wall cabinets also are available 12, 15, 18, and 24 inches high. Some of these sizes are available 24 inches deep to provide an accessible wall cabinet above a refrigerator. Wall cabinets generally are installed from 15 to 18 inches off the finished counter surface. This clearance typically is required so small hand appliances can fit under the wall cabinet.

As a standard, wall cabinets feature two adjustable interior shelves in a 30-inch-high unit. The 36-inch and 42-inch-high units generally include three shelves. To maximize the accessibility of wall cabinets, always specify wall units without a center stile. Many manufacturers install this vertical support member in wall cabinets wider than 30 inches, which blocks access. If available, specify a manufacturer that provides an open space the entire width of the cabinet.

Special-Purpose Wall Cabinets

Appliance garage. An appliance garage is a cabinet with a roll-up door, called a *tambour* unit, that extends to the countertop. It is sometimes referred to as a small appliance garage. Appliance garages also can be used with regular cabinet doors (see Figure 1.33).

Corner cabinet. Much like base units, blind corner units and pie-cut cabinets are available. An angled, diagonal corner wall unit frequently is specified. These units typically require 24 inches of wall space. The blind unit requires 27 to 30 inches of wall space to ensure a reasonable cabinet opening.

Glass door cabinet. Full glass panels or glass sheets that are framed in the door material are popular (see Figure 1.34). The cabinet interior should be finished to match the exterior. Glass may be clear, frosted, or etched. The doors also may feature decorative, stained, or leaded glass patterns.

Microwave/television cabinet. Deeper wall cabinets with special retractable swing-up doors (horizontal or vertical) are manufactured for television and microwave appliances.

Open shelf unit. Open shelf units can be mixed attractively with enclosed cabinets to provide design relief to the overall room by introducing a display of the client's collectibles.



FIGURE 1.34 Glass door cabinets used in a small kitchen
*Design by Mark T. White, CKD, CBD.
Photo by Phoenix Photographic*



FIGURE 1.35 Small kitchen with peninsula cabinetry
Design by Marie Lail Blackburn, CMKBD, CID

Peninsula cabinet. This type of wall cabinet is accessible from one or both sides, attached to at least one wall, and spans an open space between two rooms (see Figure 1.35).

Special interior accessories. Such accessories include door-mounted spice racks, interior step shelving, swing-out canned goods, or spice shelf units. Some manufacturers also offer wall cabinets that have built-in integral lighting systems which provide optimum task lighting above the work surface (see Figure 1.36).

Task lighting systems/interior lighting systems for cabinetry. Some manufacturers offer wall cabinets that have a built-in integral florescent, LED, or low-voltage halogen lighting system attached to the bottom of the cabinet to provide task lighting above the countertop work surface. Interior LED lighting systems are also available to illuminate the inside area of a cabinet when the door is opened.



Tall Units and Special-Purpose Tall Units

Tall cabinets are used for a variety of purposes in kitchen planning (see Figure 1.37). They come in two size categories: midheight, 48 to 72 inches, and full height, 84 to 96 inches.

They may be used as a tall closet with no shelves to house cleaning equipment, as a food storage cabinet with specialized swing-out shelves, or as a replacement for standard base or wall units with adjustable shelves and/or rollouts.

Tall units typically are specified in 12-, 18-, 21-, or 24-inch depths for kitchen use. These units often are available in 18-, 24-, 30-, or 36-inch widths.

Midheight units feature single-height doors. Full-height configurations include a tall door approximately 65 inches high below a smaller door. This door size is specified to minimize warpage problems.

Special-Purpose Tall Cabinets

Built-in oven unit. Cabinets that house double ovens or combination appliance stacks generally have one drawer below the oven. Single-oven cabinets have two or three drawers below the appliances. Many manufacturers provide a universal oven case, which has three drawers that are designed to be eliminated at the job site if necessary, to accommodate a double oven.

Built-in refrigerator unit. Some manufacturers offer a three-sided tall enclosure with a 24-inch-deep upper cabinet to surround a refrigerator.

Bathroom Cabinetry Units

Vanity Base Units

Some vanity base unit systems are designed to *float* off the floor and are installed 6 to 18 inches up the wall. Base cabinets, which are set on the floor, are 21 inches deep (front to back) and 30 to 34½ inches high, including a subbase or *toe kick* that is 4 inches high.

Cabinetry designed for bathroom storage include special-purpose base cabinets for linen storage, built-in hampers, and specially divided drawer or pullout storage for grooming aids and cosmetics. Suspended drawers are available to be used in a sit-down area sometimes planned for a grooming/makeup counter. For children's bathrooms, a step stool is available, which is concealed in the base cabinet toe-kick area or hidden in a low drawer.

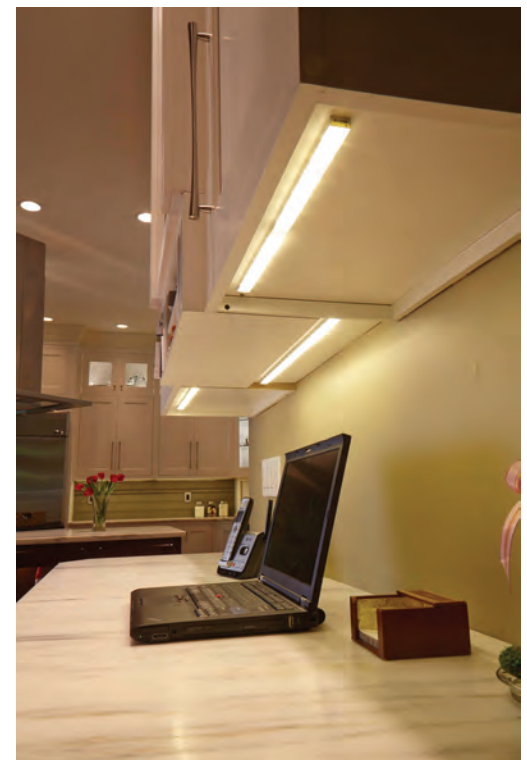

FIGURE 1.36 LED cabinet lighting systems: An LED lighting system can be incorporated in base and/or wall cabinets. LED cabinet lighting greatly improves visibility into and under cabinets.

Courtesy of Rev-A-Shelf



FIGURE 1.37 Example of tall pantry solutions

Courtesy of Wellborn Cabinet, Inc.

lavatory or toilet areas (see Figure 1.39). Tall cabinets to be used as linen or utility cabinets are 84, 90, or 96 inches high (see Figures 1.40, 1.41, 1.42, 1.43, and 1.44). Some units offer concealed drop-down counters, providing a seated space in a small bathroom.

Wall Units

Wall cabinets traditionally were designed for kitchen usage. However, creative designers adapt various wall unit sizes for interesting and functional bathroom applications. Specialized cabinets designed to be placed over the water closet (toilet) and extending down to the vanity countertop are offered in some lines in 6- to 8-inch-deep bathroom units.

Tall Units

Tall cabinets provide excellent storage in a bathroom space when countertop requirements have been met (see Figure 1.38). Tall cabinets are attractively used to separate double lavatories, or to flank

Fitted Furniture Cabinetry for Other Rooms of the Home

The kitchen and bathroom specialist often is asked to extend his or her expertise into other rooms of the home that would benefit from custom-designed built-in cabinetry. (See Figures 1.45, 1.46, and 1.47.) One such area is a home office. (See Figures 1.48 and 1.49.) The center may be a separate room, a niche off the kitchen, or a special area within the kitchen. In such a space, designers are asked to create a charging station for the family electronic equipment (phones, tablets, PCs, etc.).



FIGURE 1.38 Example of a freestanding vanity incorporating custom detailing above the mirror and a cabinet extending to the countertop. Courtesy of Rev-A-Shelf



FIGURE 1.39 Freestanding vanity is flanked by two tall units. Design by Ellen Cheever, CMKBD, ASID, CAPS, Pietro A. Giorgi, Sr., CMKBD, and Joseph Giorgi, Jr., CKD. Photo by Peter Leach



FIGURE 1.40 Mirrored cabinet slides up, revealing a television.

Design by Ellen Cheever, CMKBD, ASID, CAPS, Pietro A. Giorgi, Sr., CMKBD, and Joseph Giorgi, Jr., CKD. Photo by Peter Leach



FIGURE 1.41 Example of combining tall cabinets with grooming area units

Design by Yuko Matsumoto, CKD, CBD. Photo by Douglas Johnson Photography



FIGURE 1.42 Example of a center room bathroom vanity

Design by Elizabeth A. Rosensteel, codesigner Merideth Confort. Photo by Robert Reck



FIGURE 1.43 Example of a bathroom vanity with cabinets on both sides of the mirror.

Design by Victoria Shaw. Photo by Tim McClean Photography



FIGURE 1.44 Example of a bathroom vanity with tall cabinets and a laundry hamper.

Design by Karl F. Utzman. Photo by Jim Brady

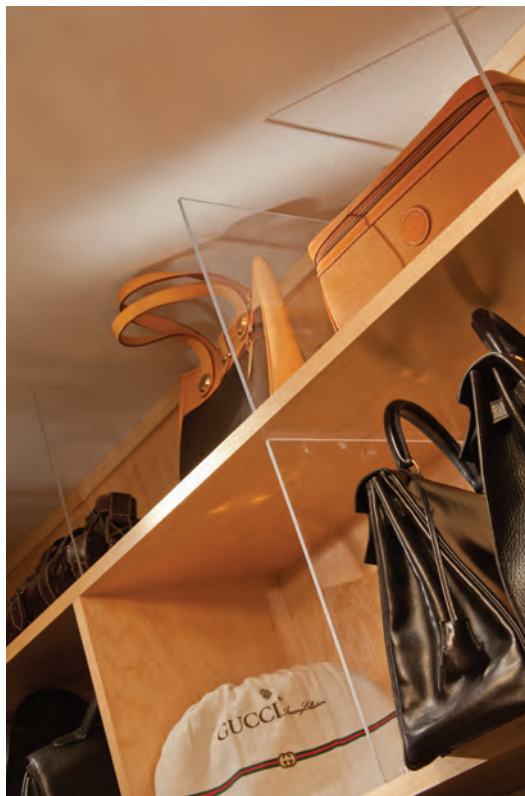

FIGURE 1.45 A woman's closet incorporating rollout drawers, adjustable shelving, and plexiglas dividers to organize the space.

Design by Pietro A. Giorgi, Sr., CMKBD, Ellen Cheever, CMKBD, ASID, CAPS, and Joseph Giorgi, Jr., CKD. Photo by Peter Leach



FIGURE 1.46 Glass doors provide visibility to the items stored within. A center island facilitates storage.

Design by Pietro A. Giorgi, Sr., CMKBD. Photo by Peter Leach



FIGURE 1.47 A man's closet designed to organize the owner's tie collection.

Design by Pietro A. Giorgi, Sr., CMKBD. Photo by Peter Leach



FIGURE 1.48 A home office with a variety of storage options

Courtesy of Showplace Wood Products, Inc.

Other areas of the home that can benefit from a designer's knowledge are media centers, entertaining counter/bar areas, children's bedroom storage, laundry rooms, hobby centers, and garage workspaces. These are just a few of the rooms you may be asked to design.

Just as designing a kitchen or bathroom requires specialized training, so too does designing these auxiliary spaces. Utilize your knowledge of cabinetry construction and size flexibility while developing a specialized questionnaire to clearly understand what clients hope to accomplish in these other areas.

CABINET CORE MATERIALS

In both frameless and frame construction, the cabinet core materials (case and door component parts) determine cabinet stability. An overview of cabinet materials currently used by both large manufacturing facilities and smaller custom cabinet shops is presented next. Some of these materials are used for both cabinet component parts and as door substrates.

Composite Core Platforms

Today, with the advent of new technology and improved resin and glue methods, the best interior surface for many cabinet applications is an



FIGURE 1.49 A home library featuring a built-in bookcase

Design by Pietro A. Giorgi, Sr., CMKBD and Ellen Cheever, CMKBD, ASID, CAPS. Photo by Peter Leach

engineered substrate that has been covered with either a high- or low-pressure decorative laminate or hardwood plywood.

Particleboard

Particleboard was originally a byproduct of the western lumber and plywood mills, which utilized sawdust, shavings, and other fall-off from the industry and was considered waste. Today, lumber mills and woodworking facilities use these wood particulates to make particleboard; hence, the name. Because some type of particleboard is the most widely used core material for cabinet construction today, trees are now harvested specifically for particleboard production.

Particleboard obtained its name based on its composition of particles of wood fall-off bonded together with resin under pressure. The size and species of the particles in this type of engineered substrate generally vary depending on the designed end use.

For example, underlayment is a form of particleboard that has a low-density and low-resin content. Therefore, it is not recommended for a laminate substrate because it has lower dimensional stability, structural strength, and moisture resistance.

Most particleboard used in the kitchen and bath industry is rated using three classifications: M1, M2, and M3. M3 is the best-quality board for laminating partly because of its superior screw-holding capability and internal bond strength; however, M2 board also is widely used. These high-quality engineered substrates usually fall in the range of 40- to 45-pound density. This density rating is the weight of the board per cubic foot. Better particleboard materials are rated as inch 45-pound commercial grade. Many times a multilayered process is used to develop the stability and screw-holding capacity of the core material.

Medium-Density Fiberboard

One of the most frequently used types of substrate material is medium-density fiberboard (MDF). This board is made of even finer fibers than normal particleboard. Its density adds

superior screw-holding power, a very tight clean edge, and an extremely smooth surface. The MDF edge can be shaped to a profile and painted, resulting in an acceptable finished edge for many surfaces. MDF is a popular substrate for painted and veneered doors.

Fire-Rated Composite Core Material

A limited number of manufacturers offer a fire-rated composite core material for use in commercial applications requiring fire-resistant capability. This board is produced under a similar process as the materials with normal cores. The primary difference is that salts are added in the manufacturing process.

This board is more difficult to cut and machine than normal particleboard, is limited in sizes available, and is stocked by only a few distributors. Additionally, the salts in the board make it susceptible to moisture. Storage conditions are therefore a prime consideration, as is a balanced glue system that will be compatible with the board during fabrication.

Plywood

Some designers and consumers consider a solid-wood cabinet to be better than one made from man-made materials. Therefore, plywood often is used as a core material in cabinet construction. It provides good strength and superior screw-holding ability. Fire-rated plywood is also available in limited sizes. Salts are added to this plywood, so the same concerns exist for fire-rated plywood as those listed for fire-rated composite core material. When considering a plywood interior, designers should specify that the face veneers on the plywood do not produce a grain rise, that a high grade of solid core plywood be used to avoid the presence of voids in the built-up layers of veneer, and that the finish surface of the plywood have only a limited number of *plugs*. Plugs are football-shaped plywood sections that are used to replace knots in the veneer.

Engineered Combination Boards

Over the last decade, new alternative core materials have been created. These materials are called engineered boards. They combine the attributes of both plywood and particleboard. For example, engineered boards are available today with an industrial board core—providing stability—and plywood layers on each side completing the overall board thickness. Such engineered board satisfies the client or architect who has specified an *all-wood* case while accommodating the manufacturing requirements of dimensional stability within the board's stock.

Bio-based Architectural Panels

Nonstructural panels are made of recycled wheat stalks. These architectural panels are referred to as *wheatboard* or *agri board*. Such panels are made from recycled wheat stalks that are milled into fine particles, sorted, dried, and then bound together with a formaldehyde-free resin. The particles are then hot-pressed into sheets of the desired thickness. The sheet is sanded and cut to required sizes. It is produced in industrial-grade sizes and strengths, and it can be machined in the same way as wood fiber particleboard.

One of the primary advantages of this product is that the resin which binds the straw fibers together is formaldehyde-free and thus is free of harmful emissions, both in manufacture and in end use. Other benefits include reducing depletion of forestry resources by utilizing an agricultural waste product and the creation of a secondary source of farm income. Manufactured in the United States under the trademark *Wheatboard*, this industrial-grade particleboard is 5 to 10 percent lighter than its wood-pulp counterpart. The adhesive used to bind the fiber is nontoxic and emission-free once cured. The adhesive is also rated as an exterior-grade binder, making the end product more water-resistant than standard industrial-grade wood-pulp particleboards.

CABINET INTERIOR AND EXTERIOR FINISH MATERIALS/SYSTEMS

The materials used on the exposed parts of the cabinets and the finishing methods are both factors in cabinet quality and price. Cabinet manufacturers use a variety of materials for construction of cabinets. Some fine custom producers have 12 or more steps in the finish process and include hand wiping and sanding between steps. You should learn all the details of the finishing process used by the manufacturers you represent.

Melamine, Foil, Vinyl Surfaces

Thermally Fused Melamine

Melamine is an organic compound that is combined with other products to produce a resin considered a synthetic polymer. The resin is applied to a substrate and is referred to as thermally fused melamine (TFM), or as low-pressure laminate (LPL), low-pressure melamine, melamine component panels (MCP), or just melamine. These are melamine-impregnated papers that can be fused to a substrate by heat and pressure.

- **Advantages.** Cost effective. Good performance for most applications; availability of colors.
- **Disadvantages.** Tendency to chip and crack, which can be mitigated with better substrates and proper cutting tools. Not as impact resistant as high-pressure laminates.

Resin-Impregnated Foil

Resin-impregnated foil is an alpha-cellulose paper impregnated with urea, acrylic, or melamine resins. It is sometimes called paper or melamine paper. In Europe, it is called foil. In North America, this surfacing is often called thermofoil or thermoplastic in the cabinet industry.

Generally, impregnated papers are offered in wood grains and some solid colors. The paper can be used for profiling and can be embossed to simulate real wood veneer graining. Some manufacturers consider their product to be a synthetic veneer.

Impregnated papers have a cost advantage over high-pressure laminate and composite panels. The cost is about equivalent of the cost of vinyl, but resin-impregnated foil has a better look than vinyl.

There is a big difference between the durability of heavier and lighter weights of paper. The paper is measured in weight per square meter. Weights range from 18- to 30-gram papers (most imported from Japan), also known as low-basis-weight-papers, through intermediate weights (40 to 70 grams). Heavyweight paper has an internal impregnation that gives it some surface integrity. The heavier the weight, the more scratch and scuff resistant the paper will be. Lighter-weight papers use waxes or silicon coatings to protect the surface, and these will wear off under use.

A simple test to judge the quality of the paper is to attach a small piece of ordinary Scotch tape for a few hours to an unobtrusive spot. When the tape is removed, the surface of a high-quality, heavyweight paper should be unharmed.

- **Advantages.** Lower cost than LPLs because it is laminated on roll-laminating equipment, which is less expensive than thermo-fusing equipment; it does not chip as easily as LPLs.
- **Disadvantages.** Most paper suppliers are foreign, which means prices fluctuate sharply with the value of the dollar.

Hot-Stamped Transfer Foils

Hot-stamped transfer foils (HSTFs) are laminated by the continuous hot-roll method. They produce good printing quality and fidelity. HSTF is paint or ink reverse printed on a Mylar carrier foil, with an adhesive topcoat. Heat and pressure activate the topcoat and deposit the ink or paint, and the Mylar is peeled away. HSTFs are offered in wood grains and solid colors and are used most often on edges and profiles.

HSTFs are self-seaming or self-trimming, since they leave only the Mylar backing where heat and pressure is applied. They can be used on medium-density fiberboard or wood but not on particleboard because it is not smooth enough to receive this type of foil surface.

- **Advantages.** Cost savings over most other methods of surfacing. Can be applied to curves and profiles with contour rollers, with virtually no evidence of a seam. Available in a wide range of colors and patterns.
- **Disadvantages.** Very thin material offers little stain, scuff, or wear resistance. Cannot fill gaps or defects, since it is almost without mass. Does not look as good on flat panels as papers or vinyls.

Vinyl Films

Vinyl films of 2 mm to 4 mm thick are used on many inexpensive cabinets and furniture items. Vinyl films are heat-laminated using adhesives. The surface of a panel laminated with vinyl film is not very durable unless it is top-coated.

- **Advantages.** Low cost; material is more impervious to water than melamine or foil surfaces.
- **Disadvantages.** Inferior quality of print and design.

Laminate Surfaces

Although laminate surfaces are used most often for counter surfaces, they also are excellent finish choices for contemporary cabinetry. Textured wood-finished laminate panels are a popular alternative to natural wood veneers. The laminate wood-textured panels are thermal fused to the backerboard material, minimizing the danger of delamination. The textured finish creates a realistic wood impression. Wood-grain laminate surfaces are easier to work with, provide a more consistent finished look, and require less care than naturally finished wood.

High-Pressure Laminates

High-pressure laminates consist of paper saturated with phenolic resin, layered and bonded under high pressure. Therefore, they are referred to high-pressure laminates (HPLs), and are produced in sheets in many decorative colors and in thicknesses typically from 0.030 to 0.050 inch. These products have been around a long time. In fact, for years they were the only laminates available. The most common uses of HPLs are for kitchen countertops, desktops, dining room and dinette tables, and restaurant countertops and workstations.

- **Advantages.** Best performance of any laminate for most purposes; available in a multitude of colors; readily available from several manufacturers in the United States, Canada, and Europe.
- **Disadvantages.** Relatively expensive; performance features may be excessive for most applications.

Continuous High-Performance Laminates

Continuous high-performance laminates are made of the same raw materials as HPLs and have the same basic characteristics as HPLs but are thinner and slightly softer. This means durability and impact resistance are proportionately lower.

- **Advantages.** Lower cost than HPLs but have many of the same performance characteristics; prelaminated panels available. Can be formed and rolled over carved door panels, as well as edging.
- **Disadvantages.** Less durable than high-pressure laminates.

Edge-Banding Choices

When considering laminate cabinetry, the edge-banding material must be evaluated also. Seven major edge-banding choices are available:

1. **Laminated vinyl.** A lamination of two materials, generally vinyl to vinyl, although ABS and paper backers may be used. The carrier is generally a rigid PVC 0.101- to 0.030-inch

thick and may be clear or in color. The surface is a printed or solid color lamination grade vinyl, usually reverse printed, and 0.002- to 0.008-inch thick.

2. **PVC.** A thermoplastic edge banding made of polyvinyl chloride, used to match vinyl, paper, paint, or high-pressure laminates. PVC offers unlimited color and pattern availability, a wide range of widths (to 3.5 inch), thicknesses (0.016–0.187 inch), surface textures, and gloss levels. The printed surfaces, as well as the solid colors, are generally top-coated with a UV-cured resin for protection.
PVC is used mainly for straight-line and contour automatic edge-banding applications. Thicker versions are available preglued for hot air applications. PVC is not recommended for soft-form applications.
3. **Polyester laminate.** Decorative papers, often matching popular high-pressure laminates, are impregnated with polyester resin and laminated to a variety of backers. Typically produced in light and heavy weight versions, either can be preglued for heat bar or hot air application. The heavy weight version is excellent for straight-line, contour, and soft-form automatic edge-banding applications.
4. **Melamine.** The term “melamine edge banding” covers a broad range of paper edge-banding materials, including single-layer printed products, laminated foils, and continuous melamine laminates. Largely produced in Europe, melamine is an economical, preglued, automatic edge-banding product suitable for straight-line, contour, and soft-form edge-banding applications.
5. **Wood veneers.** Wood veneers that are either rotary cut or sliced from a variety of domestic and imported hardwood species. The veneers are sliced from $\frac{1}{25}$ - to $\frac{1}{15}$ -inch thick and are available plain or paper or fleece backed in varying degrees of flexibility. The backers provide stability and strength to the veneer and minimize splintering, cracking, and checking. The veneers may be finger- or butt-joined to produce continuous coil edge banding. Veneer edging products are suitable for straight-line, contour, and soft-form applications.
6. **Reconstruction wood strips.** A man-made veneer generally is manufactured in Europe. Light-colored woods are cut, dyed, and re-formed into logs before being sliced into sheets that approximate flat-cut or quartered veneer. This produces a consistent, custom-colored and grained wood veneer. These veneers can be processed into fleece- or paper-backed strips or coils for straight-line, contour, or soft-form automatic edge-banding applications.
7. **Hot-stamped transfer foils.** Laminated by continuous hot-roll method. Produce good printing quality and fidelity. HSTF is self-seaming or self-trimming. Offered in wood grains and solid colors and used most often on edges and profiles. Can be used on medium-density fiberboard or wood but not on particleboard.

Acrylic/Polyester/Lacquer Door Materials

A gloss or matte acrylic, polyester, or lacquer finishing material can be used to create a very consistent colored flat door design.

Manufacturers spray lacquer, polyester, or acrylic on the smooth substrate to create this contemporary finish (see Figure 1.50). The material is then sanded and buffed to create either a flat matte finish or a high-gloss finish. This finish typically is limited to flat doors. The finish wraps around the edge of the door so there is no edge tape requirement. The back of the door may remain matte, regardless of the exposed front sheet level.

Natural Wood

Woods are universally popular and generally available to the cabinet industry in the United States and Canada (see Figure 1.51). They are used in both local custom cabinet fabrication and in large national and international cabinet manufacturing facilities

Hardwood lumber is produced from deciduous trees that drop their broad leaves each year. *Softwood* lumber is produced from coniferous or evergreen species that have needles or scale-like leaves and remain green throughout the year.



FIGURE 1.50 A kitchen featuring acrylic doors
Courtesy of Jenn-Air



FIGURE 1.51 A kitchen featuring natural wood doors
Courtesy of Wellborn Cabinet, Inc.

Because of the differing inherent qualities and growth characteristics, the end uses of hardwoods are considerably different from those of softwoods. Softwoods normally are used in construction while hardwoods are reserved for flooring, furniture, and cabinets.

Hardwood versus Softwood

Door styles are designed two ways, using either solid wood or veneer:

1. Strips of solid wood are laid up to create a solid wood center panel and then are framed with stiles (vertical members) and rails (horizontal members), creating what is often called 5-piece solid wood doors because they have two stiles, two rails, and one center panel.
2. Veneers are constructed by adhering real wood, reconstituted wood, or wood-resembling/color laminates to engineered board substrate doors (often called slab doors).

Wood Warpage

Warping is a common worry in the kitchen and bathroom industry. The relationship between the relative humidity of the atmosphere at the place of installation and the moisture content of the wood causes changes in wood structure. If the moisture content of the wood is higher than the relative humidity, the wood will give off moisture and shrink in volume. If the wood is dryer than the relative humidity, it will take on moisture and swell.

The shrinking and swelling tendency of wood varies with the species and the direction of the grain. For minimal problems, the moisture content of the wood at the time of manufacture and finishing should be approximately the average moisture content that it eventually will attain in use, or slightly less. The possibility of warpage is considerably reduced when the cabinet is finished at a manufacturing facility. A cabinet that must be shipped to an area of different relative humidity should be finished, with all exposed surfaces covered, before it begins the journey. Unfinished casework installed in a new home without climate controls in place and then left unfinished for some time is a recipe for disaster.

In conjunction with the inherent warpage problem in woods, the door style construction will affect its stability. A stile-and-rail door with a fixed-in-place flat panel will not be stable. A similar door with a floating center panel will withstand humidity changes much better. A solid lumber door is susceptible to a great deal of movement while veneered plywood will overcome the wood's natural shrinkage and swelling tendencies. Alternative products also solve the warpage problems; steel, particleboards, hardboards, and laminates all relieve the cabinet of movement problems.

Popular Species

This discussion details popular solid woods used in cabinetry with a special note for woods selected as furniture-grade veneer for cabinetry. A full discussion about planning with veneers follows this review of wood concerns and dictionary of popular species.

General color—that is, categorizing wood by its color tones—is a good way to sort through the most popular species. Some hardwoods are used in the cabinet industry for both solid wood stock and veneer parts: cherry is a good example. Other woods are very rare and typically are selected only for use as a veneer: Bird's-eye maple is an example.

To begin the discussion about wood species, we have listed them in six possible color tones:

- 1. Wood that is whitish:** Ash, maple, and sycamore
- 2. Wood that is yellowish:** Birch, lacewood, Ponderosa pine, primavera, satinwood, and zebrawood
- 3. Wood that is purple or crimson:** Bubinga and purple heart
- 4. Wood that is reddish or pinkish:** Mahogany, lupus, beech, cherry, Douglas fir, pearwood, sapele, and western red cedar
- 5. Wood that is brownish:** Alder, Brazilian rosewood, elm, oak, walnut, and teak
- 6. Wood that is blackish or has gray tones:** Ebony

A more detailed description the most popular woods used in cabinetry is presented next. For more specific information about certain wood species, visit the Hardwood Information Center at the Hardwood Manufacturers Association's website (<http://hardwood.org>) or other similar information/ educational websites. However, never specify a wood you have not worked with for cabinetry without first consulting your supplier about the availability of the species in your area, the appropriateness of the wood for cabinetry, and special handling and costs associated with unusual woods. This discussion should be part of your estimating process—before the project is presented to the client—not part of the ordering process afterward.

Alder

Principally grown in the Pacific Northwest, where it is the most abundant commercial hardwood, alder is often used in place of cherry because the coloration is somewhat similar (see Figure 1.52). Red alder is a relative of birch—almost white when freshly cut, then quickly changing on exposure to air, becoming light brown with yellow or reddish tinges. Heartwood



FIGURE 1.52 Kitchen that combines alder wood and painted white finishes. Design by Richard Ourso, CKD, CAPS, codesigners Vickie Mire, CKD, CAPS, Michelle Livings, AKBD, CAPS, LEED. Photo by Chipper Hatter

is formed only in trees of advanced age, and there is no visible boundary between sap and hardwood. The wood is straight grained as well (see Figure 1.53).

Designers should be aware that alder is considered a relatively soft wood of medium density that has low bending strength, shock resistance, and stiffness.

Ash

Of the 65 species of trees and shrubs called ash, six—white, pumpkin, blue, black, green, and Oregon ash—are commercially important for lumber and other wood products. White ash grows throughout almost the entire wooded area of the United States east of the Great Plains, except the Gulf and South Atlantic coasts. It also grows in southern Ontario and Quebec. Green ash has practically the same geographic distribution, except it also grows along the coast, follows the tributaries of the Mississippi River westward across the prairies, and extends farther northward in Canada. Black ash grows along the Great Lakes and St. Lawrence River from New England westward to Minnesota and northeastern Iowa.

White ash shrinks moderately but can be kiln-dried rapidly and satisfactorily. Ash commonly is dried from the green condition in the kiln and requires 10 to 15 days for 1-inch lumber. It machines well, is better than average in nail- and screw-holding strength, and is intermediate for gluing. Other ash species have lower strength properties than white ash but still compare favorably with other native hardwoods. These species also split easier, shrink more, are average in workability, and perform somewhat less favorably than white ash when exposed to extreme cycles of moisture content.

The principal use of ash is in furniture, interior parts of upholstered furniture, kitchen cabinets, and architectural trim and cabinetry. Ash is straight-grained, still, strong and hard. White ash is superior to other ash species in these qualities. Ash also has good bending properties and high shock resistance, and it wears smooth in use.



FIGURE 1.53 Kitchen with alder wood doors
Design by Therese DuBravac

Birch

Yellow birch grows in the Great Lake states, New England, New York, New Jersey, Pennsylvania, and along the Appalachian Mountains into southern Georgia. It reaches its best development near the Canadian border. Sweet birch grows in New England, New York, New Jersey, and Pennsylvania and extends southward along the Appalachian Mountains to northern Georgia and Alabama. Paper birch has a transcontinental range extending throughout Canada to Alaska. In the United States, it occurs eastward from the Great Lake states to New York and New England.

The wood of yellow and sweet birch is relatively heavy, hard, and strong and has high shock resistance. Although the wood is difficult to work with hand tools, it can be shaped readily by machine and ranks high in nail-withdrawal resistance. Sweet birch ranks slightly above yellow birch in most strength properties. The wood of paper birch is considerably lighter than the other two birches and ranks below them in hardness, strength, and stiffness.

All birches shrink considerably during drying. Yellow birch must be seasoned carefully to prevent checking and warping. Eleven to 15 days are required to dry 1-inch lumber from the green condition to 6 percent moisture content. Because yellow and sweet birch are difficult to glue, special veneer and adhesive treatments usually are required to obtain the best results. They are glued more easily with synthetic-resin glues than with natural glues.

Yellow birch is one of the principal furniture woods in the United States because of its good machining and finishing properties, as well as its hardness, pleasing figure and attractive color. Sweet birch lumber and veneer also are used in furniture. Both species also are used in kitchen cabinets and architectural trim, paneling, and cabinetry. Much paper birch is used for specialty veneer products, such as toothpicks and tongue depressors.

Cherry

Black cherry is found principally throughout the eastern half of the United States but grows in significant commercial quantities only in the northern Allegheny Mountains.

Cherry wood is reddish and takes a lustrous finish. It is prized furniture wood and brings high prices in veneer log form. It is increasingly popular in kitchen cabinets (see Figure 1.54) and is often used in architectural trim, paneling, and cabinetry.



FIGURE 1.54 A kitchen with cherry wood doors

*Design by Tracey Scalzo, CMKBD.
Photo by Tom Harper Photography*

Black cherry is relatively easy to dry, requiring 10 to 14 days to kiln-dry 1-inch lumber from green to 6 percent moisture content. It stays in place well after seasoning and is comparatively free from checking and warping. It is machined easily, can be sawn cleanly, turns well, and planes excellently with standard cutting angles. Screw-holding ability is good. Gluing also is good except when gum streaks are present. The wood has sufficient hardness to allow it to take hard use and withstand knocks without marring.

Cherry is a popular veneer because of the repetitive cathedrals seen throughout an elevation of plain sliced cherry veneer. Special quarter-sawn cherry can be specified to create a more ribbonlike grain pattern. Typical cherry wood characteristics, such as worm tracking, will be seen repetitively throughout an elevation of cherry veneers once laid up and sequence matched for a kitchen or bath project.

Hickory and Pecan

Typically, hickory and pecan are grouped together. However, botanically, they are slightly different: The true hickory has no fruit, and the pecan hickories are fruit bearing. These two species grow principally in the eastern United States in central and southern states.

Hickory and pecan color tones can vary widely: The sapwood of hickory is white, tinged with inconspicuous, fine brown lines, while the heartwood is pale to reddish brown. Both are coarse textured, with grain anywhere from straight to very wavy or irregular.

Mahogany

In some parts of the world, mahogany is considered an endangered species. The most notable area of concern is uncertified mahogany harvested from South American rain forests. African mahogany is more readily available and is not considered an endangered species.

The wood is medium hard, pink when freshly cut, darkening to copper-red-brown with pale golden brown tones (see Figure 1.55). The grain can be straight or wavy in solid woods. The texture is medium to coarse, with growth rings distinct. Therefore, noticeable color variations are present in laid-up solid panels.

Ribbon mahogany is a popular veneer often requested by designers or clients. Sapele veneer comes from the same wood specie family as mahogany, and is often substituted for mahogany veneer because it has a more consistent striped figure with broad alternating pink and red-brown bands of wood color. This repetitive grain appearance is the result of clearer rings and the greater hardness of this specie. Sapele and mahogany both have a coppery-red color.



FIGURE 1.55 A kitchen with mahogany wood

Design by Terri Schmidt, codesigners Linda Eberle, CKD, CBD, Keven Schmidt. Photo by Edmunds Studios

Lyptus wood, a plantation-grown hardwood from Brazil, is an environmental alternative to mahogany. Details of this eco-friendly wood are presented at the end of this section.

Maple

Commercial maples grow throughout the eastern and southeastern United States, with the exception of big leaf maple, which grows on the West Coast. Maple often is divided into two classes—hard maple and soft maple. Hard maple includes sugar maple and black maple. Soft maple is made up largely of silver maple and red maple with a very small proportion of box elder.

Maple is heavy, strong, stiff, and hard; has a high resistance to shock; and ranks high in nail-holding ability. The wood turns well on a lathe and is markedly resistant to abrasive wear. It takes stain satisfactorily and is capable of a high polish. The wood of soft maples is not as heavy, as hard, or as strong as that of the hard maples.

Maple is a consistently popular wood for furniture and cabinetry (see Figure 1.56). As much as 90 percent of the maple lumber produced is further manufactured into a variety of products, such as furniture, kitchen cabinets, architectural woodwork, and flooring.

Plain sliced maple, quartered maple, and bird’s-eye maple often are used as veneer surfacing. Plain sliced maple features typical cathedral patterns. Quartered maple has a much more striped look because of the smaller size of the trees. Bird’s-eye maple is a specialty product appreciated because of the figure created when clusters of cells within the maple explode after being frozen and then thawed in cold-climate maple forests. In natural products, the bird’s-eye pattern is irregular, tending to cluster as opposed to being spread throughout the log.

For all maple veneers, the natural wood characteristics (e.g., mineral streaks) will be seen repetitively when maple veneer “leaves” are laid up together in an overall cabinet elevation.

Oak

Oak species are found throughout the United States. Commercial stands generally grow east of the Great Plains. Oaks are classified as white oaks or red oaks. Both red and white oaks are used extensively for furniture and flooring. White oak typically has a straighter grain and longer rays than red oak; therefore, it has more figures. Oak is the most popular wood for kitchen cabinets (see Figure 1.57) and is widely used in architectural trim, paneling, and cabinetry.

Oak is hard, stiff, strong, and shock resistant. It is above average in all machining properties except shaping. The wood undergoes large shrinkage while drying; seasoning must be done carefully to avoid checking and warping.

Oak veneers are popular with straight grain cuts, typically called *quartered oak* or *rift-cut oak*.



FIGURE 1.56 A kitchen with glazed maple wood doors

Design by Ellen Cheever, CMKBD, ASID, CAPS and Pietro A. Giorgi, Sr., CMKBD. Photo by Peter Leach



FIGURE 1.57 A kitchen with rift-cut oak doors

Design by Bridgitte C. Fabi, CMKBD.
Photo by Eric Hausman

Pine—Ponderosa

Ponderosa pine is the most widely distributed pine in North America, extending from British Columbia into Mexico and from the Pacific Coast to Nebraska. The wood is comparatively light in weight, soft, moderately weak in bending, and moderately low in shock resistance. The grain is generally straight but frequently shows dimpling on the tangential surface. It resists splitting when nailed but is only average in nail-holding ability. Ponderosa pine dries easily, either in dry kilns or by air seasoning, and is moderately low in shrinkage.

Ponderosa pine is the principal millwork species and is used for window framing, sashes, doors, molding, shelving, and paneling. It is well suited for furniture, kitchen cabinets, and architectural woodwork if hardness or high strength is not required.

Pine—White

Western white pine (*Pinus monticola*) grows on western mountain ranges from southern British Columbia and southwestern Alberta to northern Idaho, northwestern Montana, and eastern Oregon to the southern end of the Sierra Nevadas in California. Eastern white pine (*Pinus strobus*) grows from Newfoundland to Lake Winnipeg in Canada and southward through the Great Lake states and New England and in the Appalachians as far south as northern Georgia.

The wood of eastern and western white pine has similar characteristics. Both are moderately soft, straight-grained, light woods that are moderately low in shock resistance. They work easily with tools, are easy to glue, and hold paint very well. They do not split readily when nailed but have only medium nail-holding ability. They are easy to dry, shrink moderately, and stay in place well when properly dried. The occurrence of *wet pockets* or *wetwood* in some lumber may require special attention during drying.

Eastern white pine is more commonly used for furniture, although some western white pine is used. Western white pine often is used for colonial-period furniture reproductions.

Walnut

From ancient Greece through modern European history, walnut has been a wood favored by cabinetmakers. Walnut is a tough hardwood of medium density.

The sapwood of walnut is creamy white while the heartwood is brown to a dark chocolate brown, occasionally with purple, darker streaks. The wood develops a rich patina that grows more lustrous with age (see Figure 1.58). The wood usually is supplied steamed to darken the sapwood. It is generally straight grained but has wavy or curly grain and burling figure patterns.



FIGURE 1.58 Kitchen with walnut wood doors
 Courtesy of Plain & Fancy Custom Cabinetry

Walnut is one of the few American wood species planted on tree farms as well as naturally regenerated. American walnuts are darker in color than are those from other parts of the world. All walnuts have lively color variations due to dark brown, dark gray, and black streaks following the ring pattern in the wood. Tones can be pinkish brown with blackish-brown streaks as well.

Specialty Veneers

Designers may be asked to specify exotic veneers (see Figures 1.59 and 1.60). Working with unique veneers is a specialty. Designers should collaborate with experienced experts before specifying unusual woods. Popular veneers are discussed next.

Special cuts of American popular wood species:

- **Anigre.** Anigre has a beautiful repetitive figured pattern that makes it a popular natural material to use. Laminates with the appearance of anigre woods are also very popular.
- **Bubinga.** Bubinga is an unusual wood with a distinctive figure.
- **Lacewood.** Lacewood is a highly figured decorative veneer.
- **Pearwood.** International manufacturers use natural pearwood. Simulated laminate pearwood is also used.
- **Wenge.** Wenge, a very dark, distinctly textured wood, is used by international manufacturers.

Planning Tips When Working with Veneers

Current design trends have led to a renewed interest in both real and man-made reproductions of natural woods veneered for cabinet decorative exteriors. This interest brings new design layout and product specification responsibilities to the kitchen and bath designer. Such an extension of your skill set will help you keep your clients happy, projects on schedule, and project profits safely guarded.

Veneers allow designers to work with a product that produces unlimited visual effects. Each species offers its own interplay of color, grain, figure, and texture. Each log within a species possesses an unrepeatably character produced by the individual circumstances of its growth. Figure adds yet another variable. Curly, fiddleback, mottle, pommel , bird's-eye, burl, and crotch figures add unique texture and may be evident in varying emphasis in a given log. Definitions of these veneer figure names are included for your review later in the chapter. See "Common Veneer Terms.)



FIGURE 1.59 Bathroom with veneer wood doors

Design by Leslie Lamarre, CKD, CID, codesigners Erika Shjeflo, Casey Darcy. Photo by Bernard Andre Photography



FIGURE 1.60 Kitchen with veneer wood doors

Design by Brian M. Johnson. Photo by Phil Bell

Veneer experts recommend that designers:

- Appreciate that veneer work is very complex because layout options are species-specific and may be limited by product (the log or flitch) availability. It is important to present conceptual ideas to consumers cautiously after confirming with your supplier so that you do not *overpromise* and *underdeliver*.
- Realize the variability of pattern and color in wood veneers. This wood appearance uniqueness should be presented to consumers with as much caution as the specialist is accustomed to doing when discussing natural stone. If a client wants a perfectly matched series of wood panels, specify a reconstituted or laminate look-alike.
- Work with the natural colors of the wood. Veneers provide an impressive palette of colors: tans, browns, reds, violets, blonds, and pinks. This natural color should dictate the finish specified. If you choose to color or stain a veneer, you may lose the chatoyance of the grain pattern.
- Learn how the cutting method impacts the grain pattern. Grain patterns are naturally distinct from species to species and from log to log. The log's basic grain structure, created by the annual growth rings, produces different grain patterns depending on the direction the veneer is sliced in relationship to the log's growth rings. For example, veneers cut at a tangent to the ring (flat cut) produce narrow heart and cathedral grain patterns. Veneers cut through the radius (quarter cut) produce straight comb and ribbon-striped grain patterns.
- Understand that there are no solid wood options for imported exotic veneers such as bubinga or anigre. While it is easy to source domestic walnut solid stock to blend with domestic walnut veneers, exotic woods are not available in solid stock—it simply is not milled.
- Be prepared to overcome the consumer's misconception that veneer cabinets are less expensive than solid wood units. Unfortunately, cheap veneer wood furniture has led to a widespread misconception about the cost of veneers compared to solid wood products. Veneer work, when done right, using the most coveted logs, is more expensive than solid wood alternatives.

Veneer Cutting Methods

The way veneer is cut is an important factor in producing a variety of visual effects (see Figure 1.61). A mill conceivably could take a single panel, cut it in four/five different ways, and end up with four/five distinct-looking pieces of veneer.

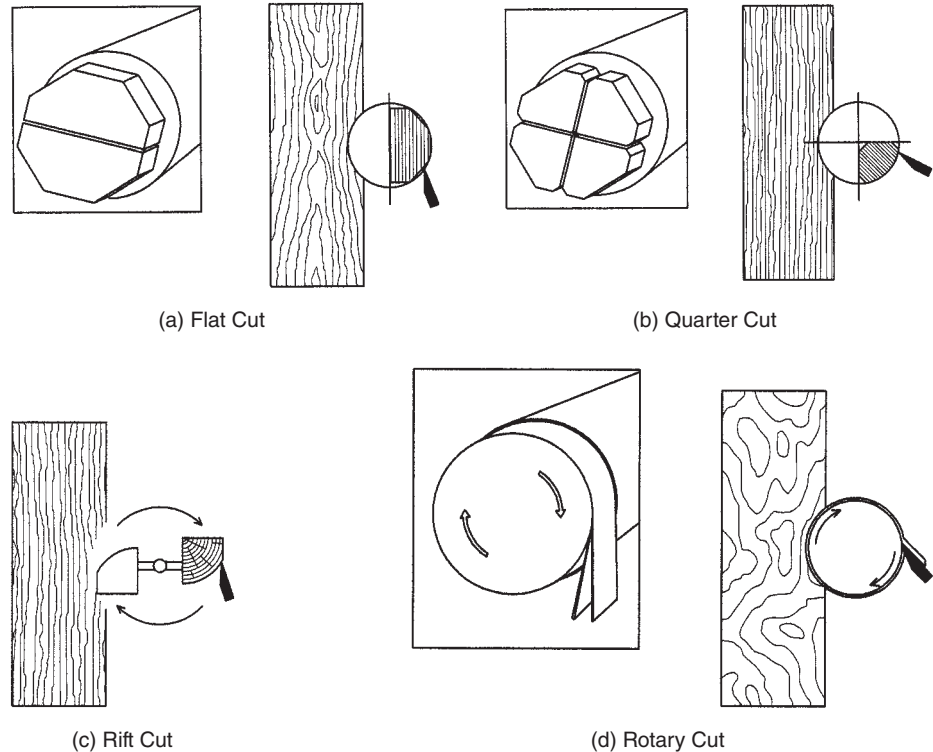

FIGURE 1.61 Veneer cutting methods
Courtesy of Dooge Veneers Inc.

Flat cut (plain slicing). A log is cut in half, lengthwise, and then placed on the slicer, where the knife cuts individual leaves of veneer parallel to the original cut. Flat cutting produces a cathedral or loop grain effect in the center of the leaf and straighter grain along the edges.

Quarter cut. A quartered section of log is placed on the slicer, and the knife cuts individual leaves of veneer at a 90-degree angle to the growth rings. Quarter cutting produces a striped effect—straight in some species and varied in others.

Rift cut. Typically, oak is rift cut. Oak produces cells that form a pattern of medullary rays that radiate from the center of the log. To avoid the bold flake effect of cutting oak on the true quarter, a quartered section of log is placed on a rotary slicer and veneer is cut at an angle, about 15 percent off the quartered position. Rift cutting produces a rift or comb grain effect.

Rotary cut. A full log is placed in the lathe and turned against a razor-sharp blade, which peels a continuous sheet of veneer along the annular growth rings. Rotary-cut veneer is exceptionally wide and produces bold, variegated grain markings.

Design Considerations

Grain matching varies with the investment made in the wood and the extent of the grain matching specified throughout the room. Following is a series of categories defining the different levels of grain matching possible for a kitchen, bathroom, or other room project.

1. In Level 1 projects (entry-level stock products), the drawer head and doors are cut en masse. Therefore, there is no grain matching on the veneer doors installed on the case. The fact that the grain pattern on the drawer of inexpensive veneer cabinets runs horizontally while the grain runs vertically for the door may not be considered a detriment by the client.
2. In Level 2 projects, the designer specifies grain matching within each unit: This means the door and drawer grain runs in the same direction and is cut from the same panel. Such a specification is more costly because it does not allow for *yield maximization* (getting the most number of doors and drawers out of each laid-up veneer sheet) when the veneer panels are cut from large 4- × 8-foot sheets of panel stock.
3. In Level 3 projects, grain is matched throughout each elevation: Each entire run of cabinets is cut from sequential panels or leaves from the same log. This type of project requires close collaboration; the designer must present a full set of finished plans to the wood supplier for sourcing and estimating before the final contract is signed.
4. In Level 4 projects, each door has balanced (centered and matched in width) veneer leaves on the surface. This effort is called *blueprint matching*. It is the customized manufacture of panels and doors of various sizes in which the entire room (not each individual elevation) is sequenced with door and cabinet component parts using continuously matched panels.

When specifying Levels 2, 3, and 4 grain matching, four special planning requirements exist:

1. The consumer must understand and accept that any damage to the veneer on the job site must be repaired by a finishing expert because the sequence-matched veneer pattern cannot be interrupted by a replacement piece. When specifying a veneer job, you already should have a working relationship with a local furniture refinisher or antique specialist because very sophisticated touch-up work in the field is required for sequence-matched veneer panels. You also can *never* order late veneer pieces for repair, replacement, or add-ons and expect them to match because they will be cut from a different flitch.
2. All appliance panels, accent pieces, and custom end panels must be cut from the same stock as the door panels. Typically, door stock is different from cabinet component parts; the mill source may even be different. Therefore, door-grade end panels and door-grade appliance panels must be ordered to maintain the grain appearance consistency. If open cabinets are mixed with enclosed units, you must contrast the materials or make sure you and the cabinet manufacturer have clearly agreed on the veneer specification and resulting procurement and assembly costing.

3. Understand that veneers never match solid woods. Therefore, it is wise to avoid using solid wood accents from the same wood species (if available) because the grain pattern, figure, and color will not match the veneers used.
4. Appreciate that when you curve veneer doors, you stretch the wood's molecular structure; therefore, the grain may take stain very differently.

Approve the veneer sample regardless of the level of complexity. For Level 3 and 4 projects, the actual flitch(es) that will best fit the specifications must be identified. This is done by inspecting veneer samples.

Normally, three leaves (sheets) are drawn from evenly spaced positions within a flitch to give a broad picture of how the grain pattern progresses through the flitch and what character marks develop. The sample is identified with the sheet and flitch number, along with a note identifying the total square footage of the flitch available. Placed side by side, these samples show the designer and client what is happening to the grain and character of the wood throughout the flitch from outside of the tree to the center.

Typically, younger wood on the outside will be narrower and will show fewer defects than wood found in the center. For upscale custom work, the client must approve the flitch sample and the log must be reserved for the project.

Only after the extensive selection process has been completed will manufacturing begin.

Special planning requirements exist when specifying Levels 2, 3, and 4 grain matching. Veneer is bundled and stored in the exact sequence in which it was sliced from the log. Before it is laid up for practical use, the designer or mill worker must select one of many methods of matching the individual leaves. Each method produces a unique visual effect and should be selected based on the type of veneer used, the visual effect desired, and the intended application.

Veneer grains are matched (laid-up) in several different ways, including slip match and book match.

Typically seen in the cabinet industry, a *slip match* is created when the pieces are joined together in the order they come from the flitch and have the same face kept up. A *book match* is created when the veneers are opened from the flitch, much like the pages of a book.

Special matches used in accent wood areas are reverse match, diamond match, and book and butt match (see Figure 1.62). These matches create a pattern by joining small veneer sections into a shaped pattern.

Alternatives to Natural Veneers: “Super-Natural” Man-Made Products

Anyone who has worked with veneers knows how temperamental they can be. Color variations, grain irregularities, and imperfections can result in low yield and much dissimilarity in the final product that will not satisfy the client.

Still, demand for veneers is growing. Sourcing raw natural veneers for projects that require minimum levels of surface structure inconsistency presents a continuing challenge. Therefore, designers are forced either to reconsider the species they want to work with or to dramatically increase budgets to accommodate the cost of super-quality raw veneers (think five-star luxury hotel prices).

One option is to consider engineered or reconstituted veneers. Another is to substitute with wood-inspired laminate products.

Reconstituted Woods

Reconstituted woods are real woods that have been reglued, resliced, and dyed to mimic woods that are more valuable. Reconstituted woods take consistency to a higher level. They are created by gluing together natural veneers in special presses and reslicing to get certain predetermined effects: faithful reproductions of either natural veneers or off-the-wall

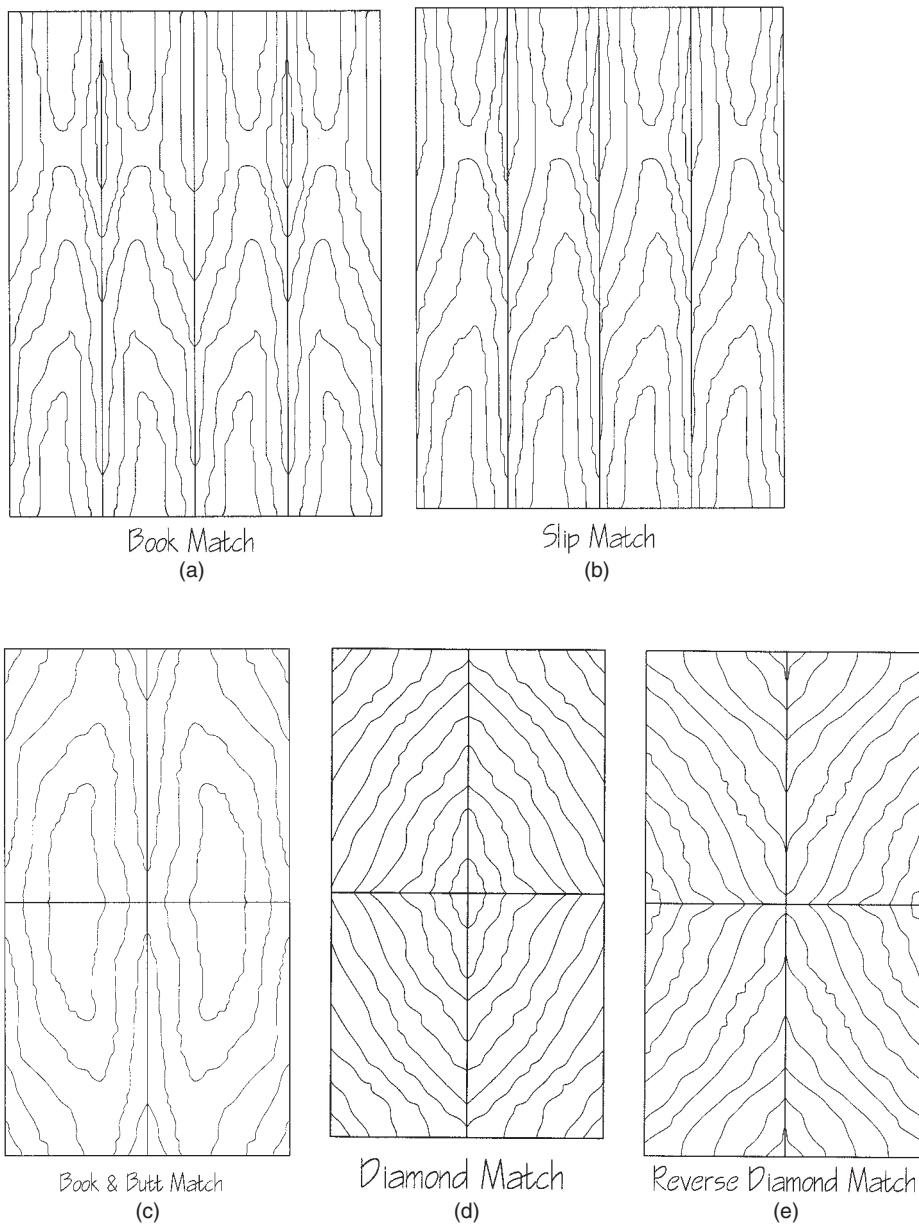

FIGURE 1.62 Veneer matching techniques
 Courtesy of Dooge Veneers Inc.

geometric effects. These reconstituted and recut veneers demonstrate a responsible use of limited natural resources, and are becoming more available in the kitchen cabinetry industry.

Engineered veneers have greater grain consistency, color evenness, and a minimal amount of natural wood characteristics (which many feel are defects) because the wood is forested from fast-growing nondescript wood species, then rotary cut, laid up, pressed, and resliced, providing extreme consistency.

Laminate Alternatives

An alternative to natural or reconstituted veneer products is a decorative high-pressure laminate substitute.

Excellent products are available today from both international and domestic suppliers. Wood-grained laminates are far more interesting today than they were years ago because of manufacturers' ability to add texture to the surface and a natural randomness to the pattern, giving it a more lifelike, natural wood sensibility.

When considering a laminate substitute for a wood veneer, securing samples is the first step. Most laminate manufacturers make samples available to order via their Web site palette collections.

In addition to flat one-dimensional wood grain, there are textured finish alternatives, ranging from abstract form/line compositions, finely embossed wood graining, and wide grain ridges replicating the sophistication of natural wood grain.

In addition to the face specification opportunities, a wide variety of core materials are available. Considerations are the weight factor of the material, the performance characteristics required (fire rating, moisture resistant?), and its GREENGUARD classification (minimal emissions or urea-formaldehyde free).

When selecting a laminate material for cabinet door and drawer surfaces, the type of edge tape or door profile is as important as the face finish. Finishing the edges with a thicker PVC tape to blend, match, or contrast with the face is one option. An attractive international solution is a finely detailed aluminum frame on doors and drawers.

For all types of natural veneers, as well as for man-made materials inspired by natural veneers, specific terms describe the appearance of the veneer (see “Common Veneer Terms”). These terms are always used when referring to natural wood and those specifically dealing with the appearance of the veneer used in man-made products.

Common Veneer Terms

Utilizes top-quality veneer and generally has special requirements for balancing, sequencing, component width, etc.

Bird’s-eye. The term given to the small to large eye-shape marking of figures found through select sheets of maple. This figure is random throughout the leaves.

Burl. Swirling grain around clusters of dormant buds, rings, or eyes. Available in white ash, olive ash, Carpathian elm, maple, mappa, myrtle, and walnut.

Chatoyance. Describes the iridescence of some veneer finishes. Created by the finishing process, which enhances the shimmer resulting when light reflects off the wood fibers at different angles. Also called moire or vibrance.

Crotch. Cut from the juncture of a tree’s main branches and trunk where the tree has forked in two directions. Crotch figures often are subcategorized as flame, plume, rooster tail, feather, or burning bush. Available in mahogany.

Curly. A grade of maple veneer with a distinctive wide band or curl figure throughout. Also known as flame veneer. Curly maple veneer with a tight figure sometimes is referred to as a fiddleback.

Face. Leaves of veneer that has been spliced together but has not yet been applied to a panel or backer sheet. In addition, the better side of any plywood panel in which the outer piles are of different veneer grades.

Fiddleback. Narrow bands of figure that run uninterrupted from edge to edge across the width of the veneer leaf. When book matched, a chevron pattern is formed. Most commonly available in anigre, maple, makore, and English sycamore.

(continued)

Figure. The pattern produced in a wood surface by annual growth rings, rays, knots, deviations from natural grain, such as interlocked, and wavy grain and irregular coloration.

Flares. Markings across the grain of the face. In book-matched material, the markings seem to extend across the width of the face.

Flake. Varies in size from dash marks to stretch marks. Created when the pith rays are cut across at an angle when slicing. Very common in quartered red and white oak.

Flitch. The complete bundle of thin sheets of veneer after cutting, laid together in sequence, as they were sliced or sawn.

Grain. The direction, size, arrangement, and appearance of the fibers in wood or veneer. The 8-foot grain direction in 4 × 8-foot veneer and plywood.

Hardwood. General term used to designate lumber or veneer produced from broad-leaved or deciduous trees. This is in contrast to softwood, which is produced from evergreen or coniferous trees.

Heartwood. The nonactive center of a tree generally distinguishable from the outer portion (sapwood) by its darker color.

Joint. The line between the edges of two adjacent leaves of veneer.

Joint, Open. Joint in which two adjacent pieces of veneer do not fit tightly together.

Knot. Cross section of a tree branch or limb with the grain usually running at right angles to that of the piece of wood in which it occurs.

Knot, Open. Opening produced when a portion of the wood substance of a knot has dropped out.

Knots, Sound, Tight. Knots that are solid across their faces and fixed by growth to retain their place.

Leaf (Leaves). Sliced sheet of a veneer flitch.

Log. The section of a tree that can be sawn or used for veneer.

Mottle. Describes a variegated or block pattern figure. The grain lines are broken and irregular, which differentiates the figure from curly.

Pommel  (pom-el-ay). A dense pattern of small rings enveloping one another. Resembles raindrops cascading down a window. Often described as looking like suede or fur. Most commonly available as sapele.

Softwood. Wood from trees classified as gymnosperm, primarily coniferous trees, such as pine, fir or cedar.

Adapted from Form Wood Industries, www.formwood.com/veneer-glossary.html

Finishing Systems

Although most cabinet manufacturers supply prefinished casework, designers should have a working knowledge of wood coloring and wood finishing.

Most cabinet companies finish cabinetry in the manufacturing facility. The prefinished cabinetry will then be protected from humidity changes during transport or installation at the job site. Unfinished wood can expand or shrink, which can compromise the case's stability. Damage to the wood door assembly can occur if extreme climate changes occur between cabinet assembly and cabinet finish.

A wide variety of finishing techniques is used within the cabinetry industry. Designers should review manufacturers' published information about finishing processes as well as their compliance with environmental protection guidelines or requirements.

The environmental concern regarding the cabinet finishing process focuses on limiting or eliminating hazardous substances called volatile organic compounds (VOCs). Some water-based stain systems eliminate VOCs; however, the durability of such systems may not be suitable for the planned usage of the cabinetry. Other finishing systems have been formulated to have very low VOC emission levels while providing an extremely durable finish. Regulations surrounding VOC emissions are continually changing within the cabinetry industry. Therefore, designers should work closely with manufacturers to understand chemical emission control or elimination efforts under way within the specific manufacturer's finishing department or as regulated by state environmental codes.

Variations in Color

The designer must understand why wood parts finish differently and why various wood species require special finishing considerations. For example, there can be different absorption rates present within one piece of wood. This defect is associated with random variation in porosity, such as the tissue around knots in pine.

The variation can be caused by how the tree grows or by a bundle of fibers growing in a wavy fashion within the tree and at angles to the vertical axis. When the log is cut, some bundles of fiber are cut parallel to the main direction of growth and some are cut at an angle, exposing the fiber end with its open water-conducting channels or pores. Such open surface inevitably will assume darker hues than surfaces composed of near-parallel bundles of fiber, producing a "blotchy" effect when stain is applied. A similar variation in color caused by differing wood fibers occurs when veneer panels are rounded or solid wood moldings are curved.

Additionally, some natural wood colors will change to darker finishes in the presence of oxygen and light. For example, cherry will become much redder during the life of the furniture piece. When this darkening occurs in lacquered veneers, it is often viewed—erroneously—as the fault of the finish.

Successful designers carefully and completely review the types of color variation the client should expect and be willing to accept before the cabinet order is placed.

Enhancing Natural Wood Tones

The natural color of the wood can be enhanced simply by adding a coat of oil. The approximate color resulting from a transparent finish can be determined with a *wet test*. Simply moisten an area of the unfinished wood with clean water. The more porous woods will show a greater change in color than woods with closed grains.

Staining Woods

Stains are employed to bring out the full beauty of the grain or to emphasize the color of the woods. Woods with no color that must be stained are basswood, poplar, gumwood, and white pine. Light-colored woods that may be finished in their natural color or stained include ash, beech, birch, cherry, elm, oak, maple, chestnut, and mahogany.

Stain usually is not used on veneers or wood with natural beauty and rich color, such as butternut, mahogany, rosewood, teak, and walnut. These woods, which have a natural beauty of pattern and color, should receive a clear finish, which will magnify their beauty.

It must be remembered that a stain is not a finish and that a finishing coat must be applied over it, except in the case of varnish stains, penetrating wood-sealer finishes, and lacquer-containing stain.

Types of stain:

- **Water stain.** Powder, best applied with spray equipment. Will raise grain of wood. No preliminary sealer coat required.
- **NGR stain (non-grain-raising).** Stain in which powders are dissolved in a solvent other than water to minimize the problem of grain raising. Best applied with spray equipment, which carries mixture into the pores of the wood and later evaporates.
- **Spirit stain.** Powders soluble in alcohol, which are very quick drying. Best applied with spray equipment. Can result in a slight muddiness in the finish.
- **Pigmented wiping stain.** Effective in staining a cabinet made from different woods. Pigments are suspended in a penetrating resin vehicle to allow for more color coverage to conceal the differences in the various woods being used. This type of stain requires a wiping step in the finishing process.
- **Varnish stain.** Not often used for fine wood finishes, these stains fill, color, and add a gloss to the surface, all in one coat. When a product is made from less expensive grades of lumber, varnish stains may be successful because they give a uniform coloring to woods streaked with very soft and porous parts.

Coloring Woods

Paint, colored lacquer, and tinted varnish all provide a painted appearance on cabinetry. Painting will conceal the wood grain on tightly grained wood species. During painting, an undercoat primer with no gloss is applied, followed by a finish coat of high gloss, semigloss, or satin.

A colored lacquer or a tinted varnish provide a painted appearance as well; however, the grain is still seen through the finish. Pickled finishes (white pigment rubbed into woods to enhance the grain) give wood cabinets the look of an antique scrubbed surface. Pickling is most dramatic on woods with large pores, such as oak and ash, although it works well on others too.

Additionally, paint dragging—white or off-white paint left in cabinet joints and within distressed sections—heightens this old-world antique look. This appealing vintage effect works beautifully in many kitchens and bathrooms.

Sealing Woods

A sealer coat should be applied to a wood surface after a stain has been used, unless otherwise directed. The sealer coat is normally a thin coat of the material used for the coloring. The purpose of the sealer is to keep the stain from bleeding into succeeding coats, by sealing the pores and to smooth the wood for the final finish.

Top Coating (Finishing) Wood

The finish coat will give a high-gloss, stain-rubbed, or polish-rubbed finish. The most common clear finishes are lacquer, oil, penetrating wood sealer, polyurethane, varnish, and wax.

- **Lacquer finish.** A finish that generally has replaced varnish and shellac. Spray equipment is required for proper application. Lacquer offers a hard, durable, water-resistant surface. It is mirror smooth and transparent, enhances the colors over which it is laid, and brings out the beauty of the wood grain.
- **Oil finish.** A most satisfactory finish on hard or close-grained woods. When an oil finish is applied properly, the wood is impervious to water, heat, scratches and most stains.
- **Penetrating wood sealer finish and penetrating resin-oil Finish.** These finishes withstand stains, watermarks, minor burns, and scratches. These sealer finishes are of two general types: one contains wax and one contains varnish. The finish coating wax gives a soft sheen rather than a high gloss. Thin, medium, and heavy consistencies are available.

- **Polyurethane finish.** In addition to the conventional varnishes, several other synthetic clear coatings make excellent finishes for furniture. Of these finishes, the clear, oil-modified urethanes are the most popular. They are highly resistant to abrasion, scratching, water, chemicals, grease, solvents, food stains, alcohol, and oils. They form a coating on the surface without penetrating. They can be applied over bare wood, sealer, or a varnish finish. Do not apply a polyurethane finish over shellac or lacquer finish, unless it has been specifically formulated for polyurethane finishes.
- **Varnish.** Available in all gloss finishes. Provides a finish that is resistant to water, alcohol, and other liquids. Most varnishes today are made of synthetic resins that dry rapidly to form a hard surface coating that is exceptionally resistant to rough wear.
- **Wax finish.** A simple, effective way of finishing wood. Generally, the wax is applied over a dried and sanded sealer coat of shellac, varnish, or oil.

Vintage Finishes

In addition to a wide array of wood stains and fashionable colors for cabinetry, many consumers request cabinetry with hand-applied finishes creating an antique look. These finishes are reminiscent of a room that has developed the patina of a cherished but well-worn furniture piece. Generically, they may be called *vintage* (see Figure 1.63), multistep, or layered finishes.

Three broad categories of special effects are employed to create these finishes.

1. **Glazing.** Glazing is the application of a colored material after the base coat of stain or paint has been applied. There are four broad categories of glazing:
 - a. **Patting glazing.** Applied on white wood edging after wear, before finish, with pat-pat-pat/sponge rhythm.
 - b. **Burnished glazing.** Glazing applied over all surfaces and wiped off, leaving residue in all crevices and shaped elements. Also called a penetrating glaze, which means laying color into the pores of the wood, allowing it to contribute to the finished color of the wood.
 - c. **Striated glazing.** A faux finish technique where the consistency of the glazing is such that it appears to be stripes of paint left from brush strokes in both a horizontal and a vertical direction.
 - d. **Dry glazing.** Almost chalklike material is applied after burnishing with a glancing stroke: appears on lead raised edges. Identified as defining glazing, which means the wood grooves are highlighted by the glaze



FIGURE 1.63 Examples of cabinetry featuring vintage finishes

Design by James Howard, CKD, CBD; codesigners Steve Levin and Sonja Willman. Photo by Alise O'Brien Photography

2. **Physical distressing.** A person damages the wood finish to create the look of aged, beaten furniture. A variety of distressing systems are available; the techniques include dents, relief cuts, chisel cuts, peck marks, and worm tracking. Such distressing can mimic natural wear or be taken to an extreme level to create a rugged, worn look. Distressing is limited to wood; it is not applicable to veneers.
3. **Special effects.** Special effects involve the application of specialized materials to re-create the sense of an aged wood surface. Typically, many manufacturers employ three broad categories of special effects.
 - a. **Crackle.** Crackle is a random look reminiscent of common finish deterioration seen in porcelain (a very small crackle application) or weather deterioration of a furniture finish caused when the finish dries and cracks because of exposure to heat.
 - b. **Spatter/cowtailing.** Spatter can be large and watery, small pinpoint black or light/dark brown lacquer that is sprayed across the finish in a random fine pattern to add depth to the finish. Small wisps of accent paints, sometimes called *cowtailing*, may also be applied.
 - c. **Wear-through.** Wear appears on the edge of the doors, the raise of moldings, and other areas where a finish naturally would have been worn off through the continual opening and closing of doors over years of use. Wear also appears on the door, drawer, and cabinet face frame.

TYPICAL DOOR STYLES

The door and drawer fronts are the most visible parts of the cabinets, so they determine the style of the cabinets and usually set the design theme for the entire space. While a single cabinetmaker might have dozens of door styles (see Figure 1.64), they generally fall into several broad categories. Following is a selection of commonly available styles.

Cabinet door styles fall into broad categories based on their basic shape. Additional variations are created by adding special treatments, such as beading, moldings, or beadboard.

Flat Doors: Veneer and Laminates

Flat doors are flat-shaped pieces of lumber, plywood, or engineered board substrate. If a veneer is used, the designer should verify what grade of veneer and how the door panels will be laid out permitting grain consistency per cabinet, per elevation, or not at all. The kitchen pictured in Figure 1.65 features full overlay flat doors.

This type of door style may have the edges finished in a PVC edge tape designed to blend with the doors, a finger-jointed wood veneer edge tape, or a solid wood edging.

Flat Doors with a Wood Frame

Laminate or wood doors may be of a slab configuration with a wood, thick PVC edging, or metal frame around the doors and drawers. This can provide a very high-tech, contemporary look, or can have a transitional sense if laminate and wood are combined.

Flat Doors with a Continuous Pull/C-Channel/J-Channel Integral Pull

A wood or laminate slab door can have a metal or routed wood pull that replaces a surface-mounted hardware piece (see Figure 1.66). This hardware may be placed at both the top of drawers and the top of doors to create two horizontal lines through the space. Alternatively, the hardware may be at the top of the doors and the bottom of the drawers so one wider strip is featured.

Miter-Framed Doors with Raised/Flat Panels

These doors have a frame made up of two horizontal rails and two vertical stiles, which are joined by a miter in each corner, with a panel floating in between. The door may have a flat



FIGURE 1.64 Typical door designs
Courtesy of Plain & Fancy Custom
Cabinetry



FIGURE 1.65 Kitchen featuring a full
overlay flat door
Design by Anastasia Rentzos,
CMKBD. Photo by Averill Lehan/PAI



FIGURE 1.66 Kitchen with pulls at the top of the door

*Design by Laurie Belinda Haefele.
Photo by Mark Lohman Photography*

or a raised center panel. The center panel may be made up of solid wood strips laid up as one panel or a veneer center panel. When this look is created by routing a one-piece door, it is a false raised panel door. If the panel is flat, it is a recessed panel door. If the center section is raised, it is called a raised panel door. A raised or recessed panel door with an arch that is formed into the top and/or bottom rail is called a cathedral door. These doors are typically seen in traditional settings.

Mortise-and-Tenon Doors with Raised/Flat Panels

Doors having a frame made of two horizontal members (called *rails*), two vertical members (called *stiles*) that have a square joined corner, and a panel floating in the center are mortise-and-tenon doors.

The door may have a flat or raised center panel (see Figure 1.67). The center panel may be made up of solid wood strips laid up as one panel or a veneer center panel. This door style is typically seen in traditional and old world settings. It can also be used in transitional rooms.

Specialty Doors

There is a wide variety of special materials used for accent doors in kitchen and bathroom cabinetry. Several of the most popular are detailed next.

MDF Carved or Shaped Doors

MDF material is shaped to emulate a mortise-and-tenon raised or flat-panel door. This type of base material typically is used under a painted surface and with resin-impregnated foil doors, often called a thermofoil finishing system.

Stainless Steel

Accent doors that feature a stainless steel pans are popular in both European and North American kitchens (see Figure 1.68). The stainless steel pan receives a second pan of stainless steel (called a *double pan* door) or has a laminate, wood, or melamine panel to match the case interior.



FIGURE 1.67 A kitchen with flat-panel doors

Design by the Neil Kelly Company



FIGURE 1.68 Stainless steel used as an accent

Design by Laurie Belinda Haefele, codesigner Colin Dusenbery. Photo by Colin Dusenbery

Specialty Center Panels

Miter-framed doors and mortise-and-tenon doors may feature center panels of contrasting veneers, wood, wire, lattice, glass, rattan, or other specialty materials. These types of doors typically are called *frame-only* doors.

Specialty Glass Doors

Many manufacturers offer cabinet doors that emulate the look of historic mullion windows found in colonial times, when glass was so difficult to produce it could only be made in small panes. These are typically called *mullion* or *muntin* doors. These accent doors may have an arch at the top or be a square design (see Figure 1.69). The mullions may be on only the face of the door backed by a solid piece of glass or may be divided-light mullions (some manufacturers will call mullions “tru-lites,” rather than true lights). Regardless of the name, this type of specialty glass door has individual panes of plain glass, specialty glass, or beveled glass painstakingly placed within each opening created by the wood mullion.



FIGURE 1.69 Kitchen with specialty glass doors

Design by Jane Lockhart. Photo by Brandon Barre

CABINET MILLWORK DESIGN DETAILS

To accentuate fine cabinetry, traditional rooms today often feature architectural details from the past. Each manufacturer's offering of such architectural accoutrements are specific to that manufacturer; therefore, the designer will find a wide array of products to accentuate a kitchen or bathroom from the manufacturer.

These products include:

- **Columns.** Used to surround a specially designed sink or cooktop cabinet or to frame tall armoire cabinetry (see Figure 1.70)
- **Turnings.** Either half turnings flat against a cabinet or full turnings at the edge of islands, on the face of wall cabinets, or, again, around a special-purpose cabinet.



FIGURE 1.70 Traditional kitchen featuring decorative columns in armoire cabinet

Courtesy of Plato Woodwork Inc.

- **Brackets** (sometimes called *corbels*). Carved details to support mantel hoods (see Figure 1.71), countertop overhangs, and decorative shelves.
- **Curved molding**. May have classical shapes, such as a crown molding, with carved details in the form of flowers, leaves, or stylized patterns.



FIGURE 1.71 Decorative hood created with millwork details

Courtesy of Showplace Wood Products, Inc.



FIGURE 1.72 Decorative onlays add detail to hood apron panel
Design by Thomas Trzcinski, CMKBD

- **Onlay.** A decorative wood or plastic that is placed on the surface of a cabinet door or panel. Brings visual interest to flat areas and is used to decorate fireplace mantels, range hoods, and cabinetry headers (see Figure 1.72).

GENERIC CABINET NOMENCLATURE

Cabinet manufacturers use a code to designate each cabinet's size, use, and placement within the kitchen. Appendix A defines generic nomenclature and presents illustrations of various cabinets. This sample *manufacturer's specification list* will be similar to brochures provided to you by the manufacturers you sell. This list represents a stock manufacturer and includes only a fraction of the many products available to you through a custom manufacturer. In addition, this list includes only sizes and illustrations of framed cabinets. Most of the information for framed cabinets is typical for frameless cabinets.

After your review of this material, compare your manufacturer's specification brochures with this list. You will notice many similarities in both nomenclature and cabinetry.

General industry nomenclature is that the first two digits represent the width of the cabinet (12, 15, 18, 21, 24, etc.). The other sets of figures indicate height and/or depth choices, when available.

The letters generally indicate types of cabinets: B (base cabinets), W (wall cabinets), and specialty cabinets. For example, (BCW) is a blind corner wall. The letters L or R generally indicate left or right hinging. Thus, a U151284L is a utility cabinet 15 inches wide, 12 inches deep, and 84 inches high, with the hinge on the left.

SUMMARY

This chapter includes an expansive overview of the cabinet industry—from how cabinet systems are categorized by the availability of custom elements within an order, to how cabinets are fabricated and how they are dimensioned. We have also included an extensive discussion about interior storage systems based on current contemporary information provided by respected international manufacturers of storage systems and functional hardware.

In addition to this discussion on the mechanics of kitchen cabinetry, we have reviewed the decorative elements of cabinetry produced around the world. Different materials used for exteriors have been discussed, with a special focus on wood products.

Although it is not easy to compare cabinetry manufactured in imperial sizes to those manufactured in metric sizes, we have identified the differences and included charts to assist the designer in understanding the difference. The generic cabinet sizing examples included in Appendix A will give a designer an excellent overview of what types of products are available and how they are identified.

REVIEW QUESTIONS

1. What is the difference between a hard conversion and a soft conversion from imperial dimensions to metric dimensions? (See “Cabinet Sizing Systems: Imperial and Metric” pages 12–16)
2. Explain the difference between a stock cabinet, a semi-custom cabinet, a custom cabinet, and millwork cabinetry. (See “Cabinet Types” pages 2–4)
3. What is the difference in the manufacturing process between frame and frameless cabinetry? (See “Cabinet Door Hinging” page 38)
4. Explain why most frequently used items and/or foodstuffs in a residential kitchen should be stored between knee height and eye level of the principal user. (See “Work Simplification Principles Revisited” pages 25–26)
5. Explain the difference in a base corner cabinet between a Lazy Susan cabinet, a blind corner cabinet, a blind corner cabinet with a swing-out shelf, and a pie-cut corner cabinet. (See “Special-Purpose Base Cabinets” pages 44–45)
6. Explain the difference among the composite core platforms of particleboard, medium-density fiberboard, plywood, engineered combination boards, and agri boards. (See “Composite Core Platforms” pages 58–60)
7. Explain why finishing wood in the manufacturing facility protects a set of cabinets during transport or installation from warpage concerns. (See “Finishing Systems” page 80)
8. Define the four different levels of veneer work, with the first being entry-level, followed by Levels 1, 2, and 3 of custom veneer work. (See “Design Considerations” page 75)
9. In what part of the world is mahogany considered an endangered species? (See “Mahogany” page 69)
10. What is the difference between physical distressing and wear-through in vintage finish treatments? (See “Vintage Finishes” pages 82–83)
11. What is the difference between a miter-framed door and a mortise-and-tenon door, other than the choice selection of raised or flat center panels? (See “Specialty Center Panels” page 86)
12. Explain the difference between the KCMA Certification Program and the KCMA Environmental Stewardship Program. (See “About the KCMA Certification Program” pages 9–12)

Appliance Types and Planning Considerations



This chapter explains how kitchen appliances work, beginning with a discussion about how appliances are rated for energy efficiency. The chapter also includes a list of how users can impact the efficiency of their kitchen appliances.

To present this equipment review, we have divided the discussion into the three primary work centers in a residential kitchen:

- 1. Food preservation center.** The refrigerator, freezer, and other types of chilling appliances
- 2. Cleanup center.** The food waste disposal and dishwasher
- 3. Cooking center.** Includes all methods of transferring heat from either natural gas or electricity sources for the preparation of food

This third center is a complex one. Heat is transferred in a variety of ways, a wide variety of appliance configurations can be specified, and there is some new special-purpose cooking equipment. This center also includes a very important noncooking element: the ventilation system. We have included an extensive review of the various ventilation systems available, and have detailed basic duct path information that must be considered when specifying these appliances.

We conclude the chapter with a comprehensive checklist on appliance selection, placement, and installation considerations developed by the author after some 40+ years as a kitchen designer. It is our hope the practical information included in the checklist will help you remember to settle all the details before the plan is finalized, products are ordered, and the installation begins.

Learning Objective 1: Provide comprehensive information about energy efficiency ratings available for appliances as well as ways users can reduce the energy consumed when operating various kitchen appliances.

Learning Objective 2: Explain how the major appliances function in the three primary work centers in a residential kitchen. This review provides the foundation knowledge needed when selecting from various manufacturers' offerings.

Learning Objective 3: Identify and categorize what types of heat transference methods are available for the home cook.

Learning Objective 4: Describe the differences between the major categories of ventilation systems, and explain the interconnected specification requirement of appliance plus location plus duct path planning.

SELECTING MORE EFFICIENT APPLIANCES

For many years, North Americans have recognized the importance of *thinking green*—living environmentally conscious lives. Only recently have kitchen and bathroom professionals been given the tools and training to incorporate environmentally safe products and practices into their design practice.

Responsible designers and homeowners know that the phrase “think globally, act locally” applies as much to the design of the room, the family’s purchasing habits, and the use of the space and its equipment as it does to other planning and usage of the kitchen and bathroom.

Because the international need to understand and employ conservation tactics and waste management techniques is so important, we begin this section on appliances by tackling these two key topics first.

When it comes to residential conservation, just how can designers and homeowners help limit world energy consumption? Most energy specialists agree on three key actions that provide an excellent foundation for residential energy conservation:

1. Install more efficient appliances and equipment.
2. Adapt better everyday energy usage habits.
3. Improve the thermal integrity of the building.

Over the past 40 years, federal regulations have continuously challenged appliance manufacturers to develop new energy-efficient and environmentally safe equipment. The first milestone was the introduction of the EnergyGuide label in 1972. These bright yellow labels continue to provide important data during the equipment selection phase of the kitchen planning process.

Some appliances also may feature the Energy Star logo, which means the appliance is significantly more energy efficient than the average comparable model. Energy Star products exceed minimum U.S. government energy standards by 10 percent or more. A list of appliances that qualify for the Energy Star label can be found www.energystar.gov.

ENERGYGUIDE AND ENERGY STAR LABELS

EnergyGuide Label

The yellow EnergyGuide label is found on appliances and is provided by the Federal Trade Commission, the nation’s consumer protection agency (see Figure 2.1). The label helps you and your client compare appliances and their energy efficiency. This guide rates energy and water consumption, not performance. The EnergyGuide tells you:

- Key features of the appliance for easy comparison between models.
- Basic information, such as make, model, and size.
- The estimated cost to run the appliance based on electricity used and national electricity prices.
- The cost range chart compares how much the appliance can potentially cost annually versus other similar models.
- The annual estimated energy use based on average use. To find the operating cost in your client’s community, multiply this number by the rate on the consumer’s electricity bill.

The Energy Star logo is displayed when the appliance is Energy Star rated.

Energy Star Label

The Energy Star logo is an international symbol of premium energy efficiency (see Figure 2.2). In the United States, Energy Star is a program of the Environmental Protection Agency (EPA) and the U.S. Department of Energy that promotes the protection of the environment through energy-efficient products and practices.

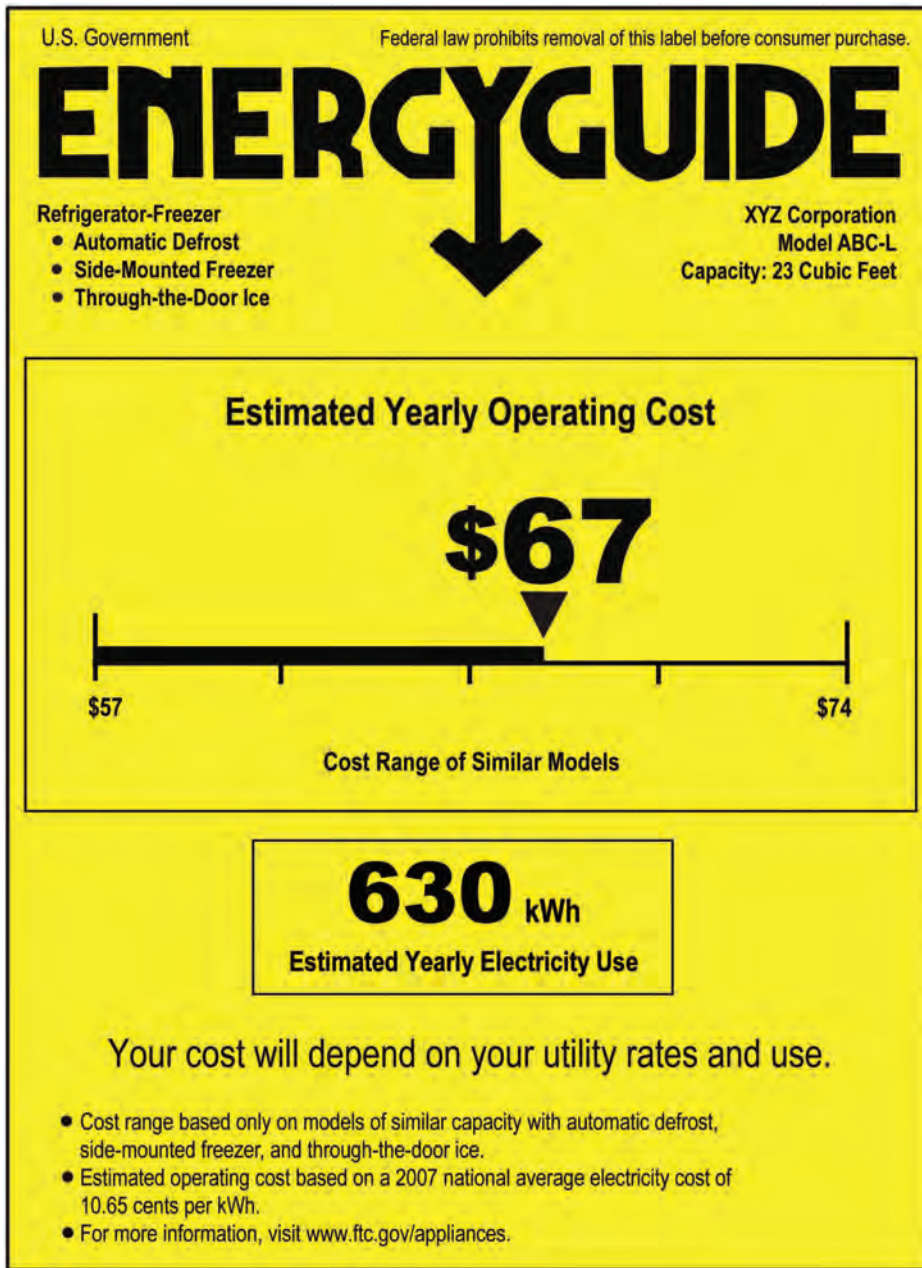

FIGURE 2.1 The EnergyGuide label
 Courtesy of the Federal Trade Commission

Energy Star was established to:

- Reduce greenhouse gas emissions and other pollutants caused by inefficient use of energy.
- Make it easier to identify and purchase energy-efficient products without sacrificing performance, features, or comfort.

Energy Star product specifications are based on these key guiding principles:

- Product categories contribute significant energy savings.
- Qualified products deliver the features and performance demanded by consumers, as well as increased energy efficiency.
- If the energy-efficient product costs more than the less-efficient product, the purchaser recovers increased initial cost through utility bill savings within a reasonable period of time.



FIGURE 2.2 Energy Star logo
 Courtesy of U.S. Department of Energy

Adopting Better Everyday Usage Habits

However, your assistance in helping the client select the most energy-efficient appliance is not enough. All family members must adopt new ways to minimize the energy and water consumption of each appliance. The next guidelines may help your clients become more conscious of the residential appliance energy usage in their own home.

Dishwasher

Scrape but do not prerinse dishes, especially under a steady stream of water. According to the EPA, washing dishes by hand uses much more water than using a dishwasher does. Using an Energy Star–qualified dishwasher instead of hand washing will save annually 5,000 gallons (18,927.06 liters) of water, \$40.00 in utility costs, and 230 hours of time.

On average, an Energy Star dishwasher uses 4 gallons (15.14 liters) of water, whereas the average non–Energy Star dishwasher uses 6 gallons (22.71 liters).

The University of Bonn in Germany conducted a study of 113 people from seven European countries, comparing their water usage with a dishwasher and without. Each person washed 12 place settings. On average, hand washing used 27 gallons (102.21 liters) of water and 2.5 kilowatt-hours (kWh) of water-heating energy. The human time it took to wash, rinse, dry, and put away was approximately 80 minutes. The dishwasher used approximately 4 gallons (15.14 liters) of water, consumed 1 to 2 kWh of total energy, and required 15 minutes of human time (loading and unloading the dishwasher).

- Do not block the spray arm action by improperly loading the dishwasher preventing water from reaching some dishes.
- If available, use *top-shelf wash only* or other cycles available for small loads.
- Wash full loads and use the energy-saving drying cycle.
- Pots and pans with charred-on soils from delayed meals or fast cooking should be scraped or soaked before placing in the dishwasher.
- Do not use the dishwasher to warm plates.

Food Waste Disposer

Always use cold water when operating the disposer to solidify fatty and greasy wastes. Use a strong flow of cold water and keep it running at least 30 seconds after the noise of grinding has stopped.

Run the disposer each time food waste is put in it. Before leaving home for several days, check to be sure that all waste has been flushed out of the disposer to avoid odors developing. If odors do occur, they can be removed by running orange or lemon peels or ice cubes through the disposer.

When washing dishes in a sink with a disposer, check to be sure all small objects have been removed from the sudsy water before draining the sink.

Periodically (and always after disposing of fibrous food wastes) purge the drain line by filling the sink with 2 to 3 inches of cold water. Turn on the disposer and allow this water to run through with no waste added.

If the home uses a septic tank, plan on cleaning the tank twice as often as normally scheduled.

Kitchen Waste Management

Kitchen waste management is another important part of residential energy conservation.

The solution to our management problem is centered in three areas: reduction, recycling, and control. We can produce less waste, we can reuse more of what we would otherwise throw away, or we can allow the consumer product itself to be controlled by virtue of its disposability.

Well-planned kitchens include multiple recycling bins in or near the primary cleanup area, allowing easy sorting of materials to be recycled and those to be disposed of.

Refrigerator/Freezer

Open the door only when necessary and for a minimum amount of time. Organize the storage items in the refrigerator. Label all frozen food packages.

Do not overload the food storage compartment, especially with items that do not require refrigeration.

Cover all liquids and most foods before placing in the refrigerator. The food will retain its quality better by not allowing extra moisture to escape. (Extra moisture places an extra load on the defrost system.)

Keep the freezer compartment as full as possible. This will reduce cold air lost when the door is opened.

Locate the refrigerator-freezer away from other heat-producing equipment, such as the range or heat vents, and out of direct sunlight.

Check to make sure there is the proper amount of clearance for a refrigerator/freezer with back-mount condenser coils.

Make sure the doors seal tightly. To check the gasket, close the door on a dollar bill and pull the dollar bill straight out. There should be some resistance. On models with magnetic door seals, an even more effective test is to place a light inside, close the door, and inspect the perimeter of the seal in a dark room to see if light is coming through the cracks.

Vacuum/clean the condenser coils on the back or the bottom of the refrigerator at least twice a year.

Gas and Electric Ranges

Select small appliances for some cooking jobs. Small electrical appliances often require less energy for the cooking job than the oven or the surface cooktop of a range because they have an enclosed heating element and often a thermostatic control.

Defrost frozen foods before cooking to cut down on the cooking time. A defrosted roast requires 33 percent less cooking time than one that is still frozen.

Preheat the oven only as long as necessary, usually for no longer than 10 minutes. Many recipes do not need a preheated oven.

For more efficient range-top cooking on glass ceramic and electric coil surfaces, use pots and pans with flat bottoms. Use tight-fitting covers on pots. Turn off the surface units as soon as you have finished or shortly before, and allow foods to finish cooking on retained heat.

If the range has two ovens, use the smaller one whenever possible. Bake several food items at once and then freeze for future dinners.

When using the broiler, put the food under the broiler before turning it on. Turn it off before removing food.

Do not peek! The temperature may drop as much as 25° or more every time the door is opened.

Never use the oven to heat the kitchen.

Keep the oven clean. Make sure the gaskets on the oven door provide a good, tight seal. Maintain the drip bowls under coil cooking elements so they can efficiently reflect the heat upward.

When cooking with gas, use a low or medium flame. Cooking seldom requires a high flame and then only for a short while. Tailor the size of the flame to the size of the pan. A high flame licking up the sides of a pan wastes gas.

Selecting Appliances

After considering the positive ramifications of specifying energy-efficient appliances as well as learning *use and care* recommendations useful to the client, designers should familiarize themselves with the basics of appliance operation and planning guidelines.

Metric Conversion

Once again, we must address the sizing differences between American appliances sized in inches and European appliances sized in metrics (or sometimes in inches).

- American manufacturers build all appliances to dimensions in inches and then parenthetically qualify these dimensions in metric in the technical section of their Web sites.
- International manufacturers build in metric sizing. Typically, a hard conversion to imperial inches will be listed on manufacturers' Web sites and in product literature.
- If an international manufacturer is launching a product exclusively for the US market, it may choose to engineer, manufacture, and specify all dimensions in inches on the technical part of its Web site.

KITCHEN FOOD PRESERVATION CENTER

The first home delivery of ice in America occurred in 1802. This necessitated the inclusion of an ice chest (a heavy wooden box, large enough to hold both ice and food together in a single compartment) in the kitchen. Today, refrigeration and freezing may be provided by a combined single vertical appliance or by several separate models. Regardless of configuration, the cooling system remains the same.

Selection Criteria

The following should be considered when selecting an appliance:

- Size of family, type of cooking, and entertaining plans determine recommended cubic footage of fresh and frozen storage space.
- Decor of room, size of room, and project budget will be used as a guide to select between built-in/freestanding and the use of panels with cabinetry material/appliance color.
- Family kitchen usage and room size are primary considerations when planning point-of-use refrigeration beyond the primary appliance.

Method of Cooling

The most important concept to grasp is that refrigeration is the removal of the heat that causes food to deteriorate (see Figure 2.3). Tests have shown that bacteria multiply rapidly at

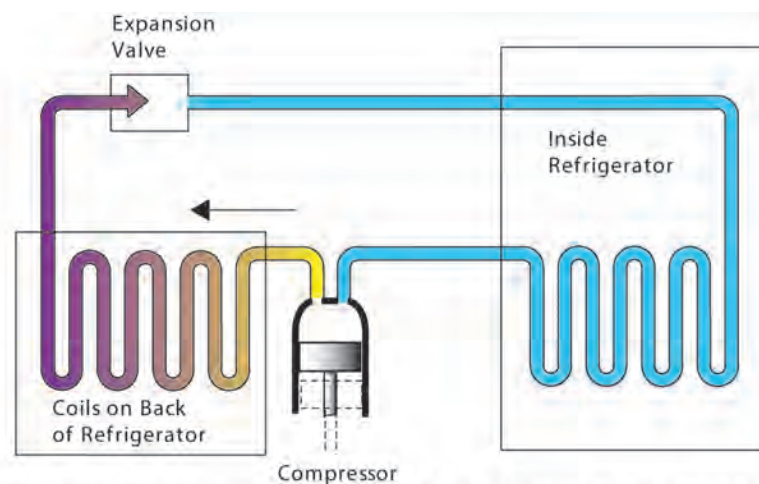

1. The compressor compresses a gas that has a low boiling point, such as ammonia. As it compresses, the gas heats up.
2. The coils on the back of the refrigerator allow the gas to cool to room temperature, but it is still under high pressure.
3. The gas flows through the expansion valve, which releases the pressure, thus cooling gas below room temperature. The now cold gas flows through coils inside the refrigerator, cooling the interior.
4. The gas flows back to the compressor to repeat the cycle.

FIGURE 2.3 How a refrigerator works

warm temperatures; therefore, all modern refrigerators are constructed to maintain temperatures at no more than 40° F (4.45° C). Lower temperatures usually are recommended for specific foods: between 32° F (0° C) and 35° F (1.67° C) for milk and 25° F to 31° F (–3.89 C to –.56° C) for fresh meat, for example. It is because of these different temperature requirements that many refrigerator models include different compartments for meats and vegetables so currents of extra cold air can be circulated around the specific compartment. The appliance design elements are described next.

Enclosure

Refrigerator cabinets are made of various materials designed to create an inner and outer shell with insulation between. Experiments have proven that 80 to 90 percent of the heat that gets into the refrigerator comes through the walls of the appliance. Consequently, a great deal of engineering and design time is spent perfecting the insulation and making sure the door gaskets provide a tight seal.

Compressor

The compressor consists of a motor and pump sealed inside a steel case concealed within the refrigerator structure. The pump compresses refrigerant vapor that concentrates the heat and sends it to the condenser.

The majority of manufacturers have engineered an appliance with one compressor used to support both the fresh food and frozen food refrigeration temperature and air-quality requirements. Single-compressor refrigerators protect against food spoilage by maintaining a constant temperature. Temperature fluctuation can quicken food spoilage. An internal sensor system monitors and regulates the temperature so that it remains constant to maximize the food preservation capabilities of the appliance.

Some appliances offer a dual compressor system. Pioneered by Sub-Zero Freezer Co., the dual refrigeration system keeps fresh food fresh longer and preserves frozen food longer because of the two separate self-containing cooling systems—one for the refrigerator and one for the freezer. Sub-Zero's company literature explains the dual compressor system by comparing it to apartment dwellers. A refrigerator/freezer is like a duplex, where the residents of one apartment like moist, 38-degree air and the residents of the other like dry, zero-degree air. If the two must share a cooling system, both will be uncomfortable. With dual refrigeration, both the fresh food compartment and the frozen food compartment get exactly what they need. When air is transferred between the fresh and frozen food compartments, tastes also are transferred from some foods to the others.

Condenser

The condenser is a long folded tube that receives hot, high-pressure refrigerant vapor pumped by the compressor. As the heat leaves, the vapor inside it cools and condenses back to liquid. Condensers in many built-in refrigerators are located at the top of the appliance. Freestanding refrigerators are engineered with the condenser on the back or underneath the appliance. The capillary tube connects the condenser to the evaporator, metering the flow of liquid refrigerant to the evaporator.

Evaporator

The evaporator, also a long tube, receives liquid refrigerant from the condenser. The liquid boils and vaporizes as it picks up heat from inside the cabinet. In a side-by-side refrigerator, it may be found behind the rear wall of the freezer, whereas in a top- or bottom-mount appliance, it is usually found between the refrigerator and freezer.

Configurations of Refrigerator and Freezer Appliances

There is a wide variety of refrigerator and freezer appliance configurations to consider when specifying for your clients.

- **Stand-alone refrigerator and freezer appliances.** Sometimes referred to as *towers*, separate refrigerator and freezer appliances are available as narrow as 18 inches wide and up to 36 inches wide. These single-purpose appliances are upright vertical units that are



FIGURE 2.4 Tower refrigeration:
Appliances can be combined in various configurations.
Courtesy of Thermador

typically designed to be installed flush with or integrated into the cabinetry, as seen in Figure 2.4.

- **Combination refrigerator/freezer appliances.** The most popular combination appliances are configured:
 1. **Freezer above/refrigerator below.** This entry-level type of refrigerator is a freestanding appliance requiring air circulation around the unit.
 2. **Freezer drawer below left- or right-hinged refrigerator door.** These appliances typically are designed to be flush with or integrated into the cabinetry, as seen in Figure 2.5.



FIGURE 2.5 Refrigerator integrated into cabinetry with matching wood panels
Design by Ellen Cheever, CMKBD, ASID, CAPS
Photo by Peter Leach

3. **Two-door/one- or two-drawer configuration.** Often called *French doors*, this configuration places the refrigeration portion of the appliance behind two doors, with the freezer in one drawer below. (See Figure 2.6.) Some models include a middle refrigerator drawer to provide a separate compartment, which can offer special temperature controls. This configuration is available in standard depths and counter depths or as integrated systems.
4. **A single appliance with a vertical freezer and vertical refrigerator compartment.** (See Figure 2.7.) This configuration provides an organized shelf system in the freezer compartment; however, the refrigerator space may be limited in smaller-width models. Some units are available with glass inserts in the door.



FIGURE 2.6 Surrounding a refrigerator with cabinetry gives it a built-in appearance even though it is not flush with the cabinetry.

Courtesy of Showplace Wood Products, Inc.



FIGURE 2.7 A stainless steel refrigerator fully flush integrated with the cabinetry

Courtesy of Jenn-Air, Design by Mary Jo Peterson, CKD, CBD, CAPS, CAASH

Special Features Available

Some refrigerators have a filtered water accessory inside the refrigerator section of the appliance. Some models have an exterior-located filtered water and ice dispenser accessory available. There are a few models available with a glass door front. Today, appliances are being introduced that include LCD touch screens and Internet connectivity. Discussions abound about new refrigerator appliance innovations that will track the foods stored within.

Temperature-Controlled Compartments within the Refrigeration Appliance

All types of refrigerators should maintain 33° F to 38° F (.56° C–3.33° C) in a fresh food section. A few refrigerators/freezers have special compartments with temperatures a few degrees cooler or warmer than the rest of the fresh food section. An example of a cooler area is a meat keeper compartment that is connected to the air circulating around the freezer section. A refrigerator has a single temperature control, while the refrigerator/freezer model has either single or multiple controls for the fresh food and freezer sections. In most models with multiple controls, the primary sensor is in the fresh food section. In these models, the refrigerator may not run enough to keep the freezer temperature low enough if the room temperature around the refrigerator is lower than 60° F (15.56° C) or if the fresh food section has large amounts of very cold food in it (such as frozen food defrosting).

Controlling/Removing Ethylene Gases in the Refrigeration System

There is a lot of talk about controlling the emission or transfer of ethylene gas within some refrigerator systems. Ethylene gas is emitted from enzymes inside certain fruits and vegetables as they ripen. These gases can cause other specific fruits and vegetables to deteriorate more quickly; therefore, food preservation is enhanced if these two groups are stored apart from one another.

Fruits and vegetables emitting ethylene gas include: apples, apricots, avocados, ripening bananas, blueberries, cantaloupe, citrus fruit (not grapefruit), cranberries, figs, guavas, grapes, green onions, honeydew, mangoes, melons, mushrooms, nectarines, okra, papayas, passion fruit, peaches, pears, persimmons, pineapple, plantains, plums, prunes, quinces, tomatoes, and watermelon.

Fruits and vegetables that become damaged by ethylene gas include: asparagus, broccoli, Brussels sprouts, cabbage, carrots, cauliflower, chard, cucumbers, cut flowers, eggplant, endive, escarole, florist greens, green beans, kale, leafy greens, lettuce, parsley, peas, peppers, potatoes, romaine lettuce, spinach, squash, sweet potatoes, watercress, and yams.

Point-of-Use Refrigeration

Appliance manufacturers offer a wide variety of point-of-use refrigeration systems designed to provide smaller versions of a typical refrigerator or custom-designed units for specific food/drink products. The majority of these appliances are designed to fit underneath a normal countertop. Popular models are:

- Under-counter refrigerator drawer appliances that can be two refrigerator drawers, two freezer drawers, or a combination.
- Under-counter *mini-refrigerators*. These range from the very affordable college dorm room-type of appliance, to elegantly styled and engineered under-counter refrigerators that may include a separate ice-making compartment—an appliance perfect for a refreshment center in a specialty area in an upscale residential kitchen.
- Matching refrigerator/freezer separate under-counter with left- and right-hinged doors. Occasionally these small appliances are substituted for full-size equipment in urban living environments. They are also quite suitable for specialty kitchens planned in outdoor living areas, mini-kitchens, an adult master suite, or fully equipped second kitchens in a game room environment.

Beverage Centers/Wine Storage Units

Wine storage units are designed to be installed under the counter (see Figure 2.8) or as a tall stand-alone tower appliance.

Some varieties of beverage centers are designed to chill and store both red and white wines. Combination units chill and store wine as well as provide shelf space for other beverages.

Appliances designed for wine storage protect the bottles from light by using UV-resistant bronze-tinted glass, monitor the humidity so corks do not dry out, and minimize vibration by carefully cradling the bottles in specially designed shelf systems.



FIGURE 2.8 a. Under-counter point-of-use refrigeration; b. An Under-counter beverage center
(a) Courtesy of Sub-Zero; (b) Courtesy of Jenn-Air

Many wine storage appliances offer different temperatures at the bottom of the unit (as compared to the top), calibrated to protect red wines typically stored in the mid- to low 60° (16° C), while a cooler temperature is maintained for white wines. The control setting can be set manually to match the client's wine storage needs.

Planning Tips from Kitchen Pros

Experienced designers suggest the next considerations when selecting a new refrigerator.

Accessibility. In side-by-side and three-door models, the vertical door split minimizes the door projection into walkway spaces. The interior is also easier to access for people with limited reach. Unfortunately, though, the left- and right-hinging configuration blocks adjacent countertops on either side of the appliances. Additionally, in smaller models, the freezer may be so narrow that a frozen pie package will not fit into the space, let alone the 25-pound Thanksgiving turkey.

Appliance placement. If a client is going to reuse an existing refrigerator that may only have a few more years of service, do not plan the entire kitchen around this outdated appliance. While many refrigerators are permanently hinged in one direction, some models have reversible doors, so there is no longer a left-hinge or right-hinge limitation. If the refrigerator will be replaced in a short time, design the best kitchen first. Then suggest that your clients work with the old appliance until it is replaced with a new one with the proper hinging to support the overall design concept.

Boxed-in versus built-in versus integrated. If the appliance is framed with panels that extend to the floor, it is called a *boxed-in* look. Experienced pros caution, "Do not call this a *built-in* look." The necessary air space on each side and above the refrigerator, as well as the oversize depth of this type of freestanding unit, prevents a true built-in look. (See Figure 2.9.) For a refrigerator to be built-in, some type of trim kit from the manufacturer will be used to make a seamless transition from the side of the appliance to the adjacent cabinets. The appliance is considered to be *integrated* into the cabinetry when it has a finished face paneled in material to match the cabinets and fit into the casework so that it is difficult to see where the cabinets stop and the appliance starts.



FIGURE 2.9 A refrigerator is built into the cabinetry, creating a piece of furniture.
Design by Vincent Cappello



FIGURE 2.9 (Continued)

Decorative panel. If you are selecting a decorative wood panel for the refrigerator, be cautious about specifying a 1/4-inch sheet of paneling in a kitchen that features solid-wood raised panel doors. The graining difference between the veneer panel and the solid-wood panel might be unacceptable. If you have a heavily styled raised panel door on the cabinetry, suggest to the client that an equally intricate styled panel be ordered for the refrigerator.

Door swing. If you are planning to reuse an existing refrigerator, verify whether any door swing engineering problems limit access to the crisper bins within. Some models require doors open far beyond 90 degrees to allow bins to be pulled out from the interior. This will severely limit where that appliance can be placed. Always check the manufacturer's specifications.

Freezer location. Because the most accessible shelf space is located between 22 and 56 inches off the floor, appliances that are designed with a lower freezer are more desirable than top-freezer models. Ideally, the lower freezer should be a bin that pulls out to the user.

Glass doors. Many point-of-use specialty appliances have glass door options.

Separate units. The all-refrigerator and all-freezer residential units that are available are ideal for large kitchens where appliances are heavily used. Two general sizes are available: a pair of 27-inch units equaling 54 inches of total space or a pair of 36-inch units requiring a total of 72 inches of space.

Storage above. Ideally, a 24-inch-deep cabinet should be placed above the refrigerator so that this cabinet is accessible. A good use for this type of cabinet is vertical tray storage.

KITCHEN WASTE MANAGEMENT

Food Waste Disposer

The food waste disposer is a popular means of disposing of food waste products. Clients value this appliance because it removes food waste products efficiently, eliminating concerns with odors and rodent/insect problems associated with garbage placed in the normal trash receptacle.

Differences of opinion abound about whether a disposer can be installed in a home with a septic tank system. Plumbers generally recommend that if you have a home that is on a septic system and you are adding a dishwasher and a food waste disposer, the septic system should be 40 to 50 percent larger than one for a house without these appliances. In a renovation situation, the tank should be cleaned out twice as often if these appliances are added. Therefore, instead of every six years, it should be cleaned out every three years.

In addition to the concerns about a food waste disposer installed in a home using a septic system, verify if local codes will allow the use of this appliance. In some high-rise condominium developments, you cannot install a food waste disposer. In some municipalities, they are simply not allowed; in others, they are required.

Selection criteria for food waste disposers:

- The location for a wall-mounted electric switch, a deck-mounted air switch, or a batch-feed appliance cap switching system will be of concern when the sink is placed on an island or if a decorative backsplash is planned.
- Better disposals featuring near-silent operation are good investments in open-plan kitchens.
- The space required by the disposal inside the sink cabinet will determine the available remaining space for under-sink storage plans.

Operation

There are two types of operation available in food waste disposers. A *continuous feed* appliance operates from a toggle switch on the wall or an air switch on the sink. It operates continuously as it is fed refuse; hence the name. A continuous-feed disposer allows the most flexibility in use, but it is also the most dangerous because a person's hand or a utensil can be caught in the disposer when it is turned on.

A *batch feed* appliance is activated when the lid is turned. This is a safer appliance because it cannot operate unless the lid is in place. However, it can be more complicated to use because to activate the disposal, the lid must be in a halfway position; to use it as a stopper for the sink, it must be pushed to a full close position. This action can be confusing and require dexterity difficult for a child or an elderly family member.

Regardless of the method of activation, the disposer actually disposes of food waste in the same manner.

Six types of action are employed in the waste disposal process: hammering, shredding, cutting, grinding, rubbing, and pulverizing. As waste reaches the bottom of the shredding compartment, the whirling impeller comes in contact with the food. The centrifugal force presses the waste against the impeller arms, the fibrous waste cutting blades, and the grind positioner. As the action continues, waste is finally divided into particles small enough to pass through into a lower evacuation chamber. From this point, the particles enter the drain and flow through the drain system to exit the house. Because of the movement of food waste particles to the drain system, it is imperative that the drain line enters the wall low enough so the food waste is not forced to flow uphill. Generally, the centerline to the drainpipe at the wall should be between 17 and 19 inches high.

Many people do not realize that the effectiveness of the disposer's operation is directly related to the rate of flow of cold water. Cold water should be flowing during the entire process of disposing of food and several minutes afterward to clear the waste line. Cold water is used, not hot, so fat or grease can be hardened so it can be cut and flushed away with other types of waste. If warm water is used, grease will be melted and as it comes in contact with lower waste pipes in the system, it may harden and cause a stoppage. Many specialists recommend periodically flushing the drain lines through the disposer by filling the sink with 3 to 4 inches of cold water and then activating the disposer.

Disposers come with different amounts of insulation and different grind chamber sizes. Motor sizes also vary; larger motors provide extra thrust for tough-to-grind loads. The increased sound insulation makes it much more pleasant for the cook to use the disposer because noise levels are kept low. When reviewing the noise of a disposer in operation, designers also must alert the client about the impact the sink material can have on noise transmission.

All disposals have some type of an anti-jam feature: It may simply be a reset button at the bottom of the disposer, or it may be an automatic reversing action. In this latter case, if the disposer jams, the unit will pause for a brief time and then automatically reverse the direction of the impeller blades.

In addition to a larger motor and more insulation, better disposers also use better interior materials to improve the durability of the appliance.

If you are working on a renovation project and the client wants to reuse the food waste disposer, be cautious. Typically, existing disposers and dishwashers that are removed and left inoperable for several weeks during the renovation may not function properly when reinstalled.

If the disposer is older than three or four years, recommend that the client purchase a new one or add a clause in your contract stipulating that you will not be responsible for the operation of this appliance once reinstalled. The same concern exists for a dishwasher if it is 10 years or older.

Trash Compactor

Environmentalists do not recommend trash compactors because the decomposition process is slowed down by compacted mixed refuse. However, you may have a client who has had a compactor in the past and wishes to have a new version of the appliance.

On the other side of the argument, manufacturers feel the concern for the environment is one of the rallying cries for purchasing a trash compactor. Their argument is that when you have compacted refuse that is one-quarter the volume of that found in a loose trashcan, you minimize the burden on garbage company landfills. This is a discussion worth continuing.

Under-countertop trash compactors are typically 15 inches wide. They may have a charcoal filtering system built in or use a deodorizer to minimize the odors associated with refuse that is left at room temperature for an extended period in the compactor. Even with this deodorizing mechanism, the appliance's use and care manual will instruct the user to carefully rinse all containers before placing them in the compactor.

Some units have pullout bin doors; others have doors that swing to the left or right and include a pullout bin within the opening. Several models have a small tilt-out door at the top to facilitate disposing of one small container or such.

Compactors plug into a standard household circuit, much like the dishwasher and disposer. They are operated by motors that vary in size. The motor drives a single ram down that compacts the trash. Some appliances on the market can be operated by a foot pedal, and most have a key lock to prevent children from playing with the appliance.

Dishwasher

A dishwasher typically is installed as a built-in appliance adjacent to the sink. It may have a fold-down door or be a series of drawers. Drawers come individually or as a stacked pair. Some appliances place the controls on the top edge of the door so that the appliance can be totally concealed in the cabinetry. Interiors are available in plastic, stainless steel, and porcelain. The most popular size is 24 inches wide ($23\frac{5}{8}$ " inches for European-manufactured appliances). Both 18- and 30-wide models are also on the market.

The depth of a dishwasher varies by manufacturer. Typically, European dishwashers are shallower than are those produced by American manufacturers. Always check the specifications if you are planning an installation where the dishwasher will flush-out with the adjacent cabinet doors or cabinet case.

Selection Criteria

Large households or families who entertain extensively may require two dishwashers. The dishwasher location should be carefully plotted in relation to landing counter space for stacked soiled dishes and in relation to storage cabinetry/pantry areas. Raised dishwasher installations can provide an attractive special-height pedestal cabinet and make the appliance much easier to access.

The type of dishwashing action varies to some degree with each manufacturer. Rotating arms, fan jets, and other enhancements are used to maximize the effectiveness of the washing actions. In most machines, the water is filtered and recirculated during the washing process, thereby reducing the amount of water required. In fact, a recent research study demonstrated that dishwasher wash cycles used less energy, less time, and less water than hand washing.

Better dishwashers are insulated and engineered to reduce or eliminate any noise when the appliance is in operation.

When evaluating a dishwasher, first look at the racks. Better units offer some flexibility in racking arrangements and provide various rack height options. Most manufacturers have two racks that accommodate glasses in the top; plates and larger pieces on the bottom rack. Some manufacturers have engineered the appliance with three racks rather than two. The third rack is placed close to the top of the appliance cavity for flatware, serving pieces, and other small items. One of the most important things to understand about well-designed dishwashers is that, because of the improved washing action and better filters, prerinsing is not necessary. Filters built in to the dishwasher trap food particles and prevent them from being redeposited on the dishes. To overcome the necessity of cleaning filters, some models feature a small disposer that chops food particles and discharges them into the drain. An important feature is a rinse agent dispenser to prevent spotting and lubricate the pumps and seals.

Length of the Washing/Drying Cycle

The best water temperature for dishwashing is between 140° F and 160° F (60° C and 71.11° C). This is important both from the standpoint of sanitation and from the requirement for hot water of at least 140° F (60° C) to dissolve typical dishwasher detergents. Although many families do set their hot water tanks at 140° F (60° C), many people today are turning down their domestic water heaters to conserve energy. Therefore, newer dishwashers have thermostatically controlled delay features to allow the built-in heating element to raise the water temperature to 140° F (60° C) before beginning the washing cycle. All dishwashers have one or more washing cycles and one or more rinsing cycles as well as a drying cycle. Drying is generally done by warm air blowing across the dishes, heated by an internal heating element. Many models today have an *energy saver* switch that turns off the heating element during the drying cycle and simply relies on heat within the dishwasher and room air for drying.

The temperature of the water entering the dishwasher, the cycle selected, and the drying method selected determines the length of the washing cycle. Manufacturers also have extended the washing time to provide an excellent wash using minimal water and, therefore, conserving energy. Some manufacturers have a special cycle specified by a name or the length of the cycle that minimizes the time it takes for the dishwasher to complete washing and drying. This shorter cycle typically is accomplished by using more water and therefore compromises the energy efficiency of the appliance.



FIGURE 2.10 Dishwasher with stainless steel panels contrasting with the adjacent cabinetry

*Courtesy of Jenn-Air
Design by Mary Jo Peterson, CKD,
CBD, CAPS, CAASH*

Many municipal codes call for an *air-gap* to be installed as an overflow protection device for the dishwasher. This mechanical planning consideration is covered in the *Kitchen & Bath Residential Construction & Systems* volume of the NKBA Professional Resource Library.

Some clients may prefer a dishwasher that contrasts with the adjacent cabinetry, as shown in Figure 2.10.

Other clients may prefer a dishwasher that integrates into the cabinetry so the entire dishwasher front can be paneled to match the cabinetry or finished in stainless steel. For this type of installation, the controls are located on the top edge of the dishwasher door. Today's dishwashers offer a variety of racking options (see Figure 2.11). Although dishwashers typically are installed under the counter, they can also be raised to make access more convenient (see Figure 2.12).



FIGURE 2.11 a. Dishwasher controls located on the top edge of the door; b. Dishwashers offer a variety of racking options within the appliance.
Courtesy of Miele, Inc.



FIGURE 2.12 A dishwasher can be raised to make the appliance shelf access more convenient.

*Design by Joseph Giorgi, Jr., CKD.
Photo by Peter Leach*

COOKING CENTER

Cooking: That is what most people think about when they hear the word kitchen. A kitchen specialist needs to carefully select the equipment that will help the cook roast, bake, broil, and sauté delectable meals for family and friends. The quandary of determining which appliance (or a combination of appliances) will best suit the workspace available and the homeowner's cooking style can be resolved only by adapting a systematic approach to the selection process. Surprisingly, the old gas versus electric issue should not be your first decision:

- Step 1.** Identify the method of heat transference selected: conduction, convection, or radiation.
- Step 2.** Identify the cooking methods to be included: microwave, induction, or steam.
- Step 3.** Select the heat source: electricity or gas.
- Step 4.** Choose the appliance style.
- Step 5.** Plan the ventilation system.

Methods of Heat Transference

When it comes to cooking, we need to turn our attention away from heat sources and consider methods of heat transference. Whatever form of energy is used to create heat, the transference of it is what cooks the food.

There are five general ways by which heat is transferred.

Conduction

Conduction is a process by which heat is transferred through a substance or from one substance to another that is in direct contact with it by molecular activity. In conventional surface cooking, the source of heat starts the molecules at the bottom of a pan into rapid vibration. They strike other molecules in the metal, putting them in motion. The molecules on the inside of the pan put the layer of water molecules next to them in motion, and they, in turn, start other water molecules moving. The motion of molecules, called heat, has been given to the water in the pan. Heat has been transferred by conduction from the heat source to the pan and from the pan to the water touching it.

In microwave and magnetic cooking, the energy is placed in direct contact with the food substance, bypassing the cooking vessel. Normal conduction activity then takes place.

Convection

Convection is a more rapid process of heat transference than conduction. It involves the motion of heated matter from one place to another. This transference of heat appears in both liquid currents and in air currents. In surface cooking, water is kept in motion by convection while it heats. The layer of water at the bottom of the pan is heated first by conduction. Because of the rise in temperature, the water expands and becomes lighter. The lighter water is then displaced by the heavier cold water. In the oven, air is heated by the electric element or gas burner at the bottom of the oven. It expands and rises to the top of the oven, allowing the cooler, heavier air to come to the bottom to be heated. Therefore, convection is a natural form of heat transference. Convection ovens modify and control the air movement by adding one or more strategically placed fans.

Radiation

Heat transfers by conduction and convection are involved in cookery on top of the range. Radiation and convection are of primary concern in oven cookery. Radiation of heat takes place at the speed of light (186,300 miles per second) in electromagnetic waves. No material medium is required for its transmission. All bodies warmer than their surroundings radiate heat. If a cold object is brought into a warm room, the walls of the room radiate heat to the cold object, and the cold object, when heated, radiates heat to the walls of the room. Since the walls are at a higher temperature, they give more heat per second to the cold object than the cold object gives up. The temperature of the cold object, therefore, rises until it comes to the same temperature as the room. When an oven is heated, the bottom and sides of the oven become hot and radiate heat directly to utensils and foods in the oven. In a conventional oven, 60 to 70 percent of the heat is radiant heat.

Microwave

Microwave energy is a form of nonionizing radiation. Ionizing radiation (X ray, gamma, cosmic rays) can cause chemical changes to take place with little or no temperature rise. Nonionizing radiation (infrared, microwaves, broadcasting waves) in sufficient intensity will cause a rise in temperature but will not cause cell changes. Radiant waves are characterized by their wavelength and their frequency of vibration.

Microwaves vibrate millions of times per second and are very short waves, hence the term "microwave." There is one microwave frequency in general use for microwave ovens, 2450 MHz (wavelength 5 inches long). The term "MHz" stands for megahertz and means a million cycles. The 2450 MHz stands for 2,450 million cycles per second. This wave has vibration amplitude about the thickness of a pencil. This thickness prevents the waves from passing through the small metal mesh installed in the oven doors.

The microwave oven cooks food within the oven by activating the dipolar (water) molecules so they rotate in a rapidly alternating electrical field. Thus, the amount of moisture in food has a direct bearing on its heating rate in the oven. The molecular rotation occurs as the molecules behave like microscopic magnets and attempt to line up within the field. However, when the electrical field is changing millions of times each second, these tiny magnets are unable to keep up because of other forces acting to slow them down. Such forces, which

restrict their movement, may be mechanical, such as ice, or viscous, such as syrup. The energy of the microwave in trying to overcome these forces is converted into heat. Thus, the heat is restricted to within the food product, and the oven interior remains cool.

Microwave energy penetrates deeply into the food materials and produces heat instantaneously as it penetrates. This is a sharp contrast to conventional heating, which depends on the conduction of heat from the food surface to the inside.

Because of this energy penetration, the highest temperature occurs 1 inch in from the surface of the food. The remaining interior is cooking by conduction. The cooking by conduction takes place during the recommended standing time. Because the heat is generated within the food substance, the heat conduction process should occur without the continuing input of microwave energies. Disregard for this principle will result in overcooking of the outer surface. Because of the penetration limitation, the ideal food configuration is that of a doughnut. This allows a maximum of surface area for maximum penetration.

The exterior surface of an item cooked in a microwave oven will be lower in temperature than the interior. This is due to radiation of heat from the food surface to the cooler surroundings of the cooking vessel or oven interior. Thus, the homemaker cannot judge the doneness of a food product by the outer temperature. Nor should he or she be told that the cooking vessel will always be cool. Some utensils will require the use of a potholder for removal from a microwave oven.

The magnetron is the device that creates the waves. It is a little broadcasting station with an antenna. It has a central cathode from which electrons escape, pressured by high voltage, and as they move outward circularly, they pass by many little charged cavities in the surrounding anode. This sets up a vibration that creates the electromagnetic microwaves. These microwaves are discharged by the antennae into the wave guide. The waves enter the cavity through the wave guide and are circulated by the stirrer. It diffuses the waves in order for them to enter the food material from all directions. A transformer within the oven converts the ordinary 120 or 240 volts to a voltage between 3000 to 6000 volts. This high voltage is needed for the magnetron to operate.

To develop a sense of timing in microwave cooking, it is first necessary to know how much power is available in the oven. Research has shown that it is not uncommon for the actual available power to be 10 to 15 percent less than that specified by the manufacturers. The cooking wattage is a major factor in cooking times. Other factors include the food density, arrangement, quantity, temperature, moisture content, and bone conformation.

Microwaves can be installed in a variety of ways including placement in a wall cabinet (see Figure 2.13) or as a drawer below the counter (see Figure 2.14).



FIGURE 2.13 Microwave oven placed in a wall cabinet

Design by Pietro A. Giorgi, Sr., CMKBD, and Ellen Cheever, CMKBD, ASID, CAPS. Photo by Peter Leach



FIGURE 2.14 Microwave drawer placed below the countertop
 Design by Carl Bruen, CGR, codesigners Robin Bruen, Debbie Kerr, CKD. Photo by Wing Wang

Microwave planning tips from kitchen pros:

- Select the appliance and its door-hinging configuration before finalizing the design. The door should swing away from the user, avoiding the need for a family member to walk around an open door.
- When installing a microwave oven in a wall cabinet, select the appliance before completing the design to determine:
 1. Is the microwave shallow enough that it can fit in a standard 12-inch-deep cabinet, or is an oversize cabinet needed?
 2. Does the appliance require a trim kit, or can it simply sit in an open-air opening?
 3. Is there room to completely conceal the microwave within a cabinet and cover the exterior with a door mounted on special-purpose cabinet hardware?
- If the microwave is installed in a cabinet extending to the counter, hold the microwave off the countertop $\frac{3}{4}$ to $1\frac{1}{2}$ inches to make sure the door does not hit the counter or hit a shaped “no-drip” countertop edge.

Induction

Kitchen designers are being introduced (or reintroduced) to a new electronic cooktop heating system: induction. The system's key attributes of being very fast, very controllable, and very energy efficient are known by kitchen designers. Planners are also aware that *special* pots and pans must be used. Specifying this surface cooking system for a prospective client takes a clear understanding of how it works and what cookware is the best to use. Let us take an in-depth look at this system of heat transference.

An induction system has powerful, high-frequency electromagnetic elements under the unit's ceramic surface. When a good-size piece of magnetic material—such as a cast iron skillet or stainless steel pot—is placed on the element's magnetic field, the field transfers (induces) energy into metal. The magnetic current causes the molecules of the metal cookware to vibrate at high frequencies, creating friction that heats the cooking vessel. By controlling the strength of the electromagnetic field, the cook controls the amount of heat being generated in the cooking vessel. Such control can be changed instantaneously.

Some models have designated element locations. A new *zoneless* system is also available that allows the user to place the cooking vessel anywhere on the surface. The power level available between these two systems is different, and the number of cooking vessels that can be used on a zoneless system may be limited. Designers should carefully evaluate the differences between these two systems before recommending one above the other.

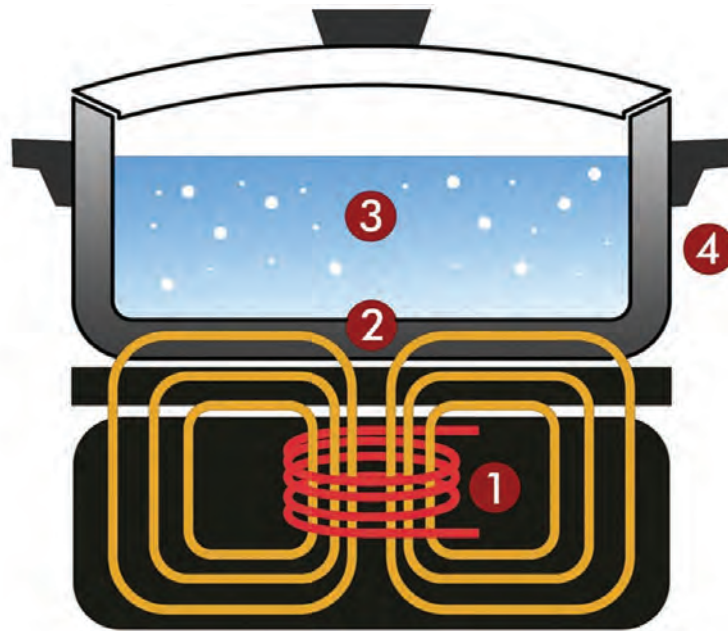

FIGURE 2.15 Diagram of how an induction cooking surface produces heat

The difference between induction cooking (see Figure 2.15) and either electric element or gas flame cooking is that the heat is generated directly in the pot or the pan itself rather than being transferred by conduction.

Advantages of Induction Cooking

- **Fast cooking—faster than gas.** Induction cooktops are faster because the technology is direct and much more efficient. Review the next list to better understand the difference between common heat sources. Moreover, elements in some induction units can share power with one another, so if not every element is in use, one can be “boosted” beyond its normal power level for such cooking activities as bringing a large pot of water to boil or preheating a fry skillet. The following example shows the time required to boil 2 quarts of water:
 - Induction: 4 minutes 46 seconds
 - Gas: 8 minutes 46 seconds
 - Halogen: 9 minutes 00 seconds
 - Electric coil: 9 minutes 50 seconds
- **There is no heat produced by the cooking surface,** so the kitchen air temperature will not be increased when the chef goes to work.
- **Safe because heat is not transferred by conduction.** When the only heat exists in the pot itself, there is no open flame, red-hot coil, or other radiant element to burn the chef

Induction Cooking

How It Works

1. The element's electronics power a coil that produces a high frequency electromagnetic field between the power source and the cooking vessel.
2. The field penetrates the metal of the ferrous (magnetic material) cooking vessel and sets up a circulating electric current that generates heat.
3. The heat generated *in the cooking vessel itself* is transferred to the vessel's content.
4. Nothing outside the vessel is affected by the field—as soon as the vessel is removed from the element or the element is turned off, the heat generation stops.

TABLE 2.1 Stated Power versus Delivered Power for Various Cooking Types

| Type | Power | Efficiency | Delivered Power |
|---------------|-------|------------|-----------------|
| Induction | 2.8kW | 90% | 2.52kW |
| Halogen | 2.2kW | 60% | 1.32kW |
| Electric coil | 2.0kW | 55% | 1.1kW |
| Gas | 3.5kW | 50% | 1.75kW |

or kitchen visitors during the cooking process. When a pot is removed, the surface is warm to the touch but not hot enough to burn.

- **Easy to clean.** Because the cooking surface is a flat ceramic top, which does not get hot, spills, splashes or drips are easy to wipe clean.
- **Energy efficient.** One of the most important benefits of induction cooking is its efficiency. Because excess heat is not lost to the air around a pan, more of the energy used in the cooking process goes straight to the pan. (Table 2.1 details the difference in efficiencies of the most popular types of cooktops.)
- **Does not require a commercial-style canopy hood or ventilation systems with high cubic foot per minute ratings.** All cooking products need to be properly ventilated because foods being prepared can create grease-laden vapors and smoke. However, induction cooking products require far less ventilation than gas or electric cooktops because they do not give off excess heat or gas emissions.

Installation Considerations

- **May require a 220 (US) volt 40 or 50 amp electrical line.** A typical electric element cooktop requires a 220 (US) volt 30 amp electrical line. Therefore, an induction cooktop often requires a higher-amperage line than typically planned for a cooktop. Such extra electric power may not be available in the current service box. The voltage required by the cooktop determines the wattage of power available to each element on the cooktop.
- **May require air circulation clearance below the cooking surface,** which means an induction cooktop cannot be placed above an oven, nor can a drawer be installed below it.

Selecting Induction-Compatible Cookware

To create the electromagnetic field, compatible cookware with a magnetic base must be used so that the heat is transferred to the food or liquid inside. Induction cooktops do not produce any heat whatsoever; therefore, nothing will happen if you place noninduction-compatible glass or copper pot on an induction cooktop surface. When the correct cookware—made of a magnetic metal or engineered with an induction-compatible conductive disk in the bottom of the pan—is used, the magnetic waves generated by the induction cooktop immediately stimulate the magnetic molecules in the pan, resulting in instant, precise, and very controllable heat.

The first test that must be performed when selecting cookware for an induction cooktop is to determine if an induction-ready metal is on the bottom of the pan. This test is conducted simply by holding by a magnet to the bottom of the pan. If the magnet sticks, the cookware is induction compatible. The stronger the magnetic bond between the magnet and the pan, the better that cookware will perform. It is important to be aware that a weak magnetic bond can cause a clicking sound when a pot is placed on an induction burner.

Cookware manufacturers are continuously redesigning their collections to be induction compatible. There are stainless pans that are manufactured that can be used on induction cooktops. The stainless uses either a carbon disk embedded or encapsulated in the bottom or uses a 400 series ferretic (magnetic) steel as a material or conductive disk. A number of manufacturers embed a 400 series stainless steel disk into the bottom of aluminum cookware, which enables the pan to work on induction cooktops. There is a lot of this construction in European cookware, where induction is more frequently found than in the United States. Not all stainless steel works. Stainless steel in the 300 series used in exteriors of pans is not magnetic. Stainless most often uses conductive aluminum disks on the bottom to transfer heat. These will not work on induction tops

It is worth noting that product innovators predict future induction cooktops will be engineered to work with *any* metal. On the horizon is newer technology that will work with any metal cooking vessel, including copper and aluminum. This new technology uses a significantly higher frequency field, which is able to induce a current in any metal. (Ceramic and glass, however, would still be unsuitable for induction cookware, even with this new technology.) Such technology is already being used in a few units made by one Japanese manufacturer, but experts predict it is still a few years away from maturity.

The second test when selecting cookware for an induction cooktop is determining how flat the bottom of the pan is. For maximum efficiency, the cookware selected for an induction cooktop must have a flat bottom.

The third test is whether it is *good* cookware. Cheap cookware has *hot spots*. It does not have ergonomic, well-designed handles. The handles may also conduct heat from the pot, making them dangerous, and they may also not be oven-safe.

Once the induction-ready metal content of the cookware has been established, the attributes of the product as it relates to general cooking should be considered.

Steam Ovens

Steaming is a method of cooking using steam, and is considered a healthy cooking technique. Steam is capable of cooking all kinds of food.

Steam cooking on the surface unit takes place when a steaming vessel sits atop a reservoir of water. As the water boils, it vaporizes into steam; the steam then carries heat to the nearby food and cooks the food. The food is kept separate from the boiling water but has direct contact with the steam, resulting in a moist texture in food products. Overcooking or burning food is easily avoided when steaming it. Some gourmet chefs claim that steaming reduces the fat content of the food because of the cooking technique and because no cooking oil is needed. Steaming also results in a more nutritious food than boiling because fewer nutrients are leached away into the water, which is usually discarded. For example, a 2007 US Department of Agriculture comparison between steaming and boiling vegetables showed the most effective nutrients were folic acid and vitamin C. When compared to raw consumption, steaming reduced folic acid by 15 percent and boiling reduced it by 35 percent. Steaming reduced vitamin C by 15 percent and boiling reduced it by 25 percent. Phenolic compounds with antioxidant properties have also been found to be retained significantly better through steaming than through boiling or microwaving.

The advantages of steaming are now incorporated in built-in ovens and combined with convection heat transference.

To understand the advantages of cooking with steam, let us start with a discussion about cooking in a water bath. There is a current interest in a cooking method first described in 1799 and then rediscovered in the mid-1960s and employed in the industrial food industry, called *sous-vide* (sü-'vêd), French for "under vacuum". *Sous-vide* is a method of cooking food sealed in airtight plastic bags in a water bath for longer than normal cooking times—72 hours in some cases—and an accurately regulated temperature much lower than normally used for cooking (typically around 131° F to 140° F) meats and higher for vegetables. Advocates of this method feel that this is the best way to cook an item evenly and to prevent it from being overcooked on the outside; therefore, the food is the juiciest.

The limitation of *sous-vide* cooking is that the low temperature does not brown foods. In addition, the flavors and texture produced by browning cannot be obtained with only the *sous-vide* technique. Therefore, food products must be browned after being removed from the water bath using techniques such as grilling or searing in an extremely hot pan or with a blowtorch.

For *sous-vide* enthusiasts, it is all about control. In normal cooking, heating stops a few degrees below the targeted temperature while residual heat continues to cook the food for a while, and overcooking can be the result. In *sous-vide* cooking, the process stops when the



center of the food has reached its targeted temperature. It is then removed and will not cook more after it stops being heated.

The steam and convection oven offers an ideal *bridge* appliance. Because the food is surrounded by a vapor blanket of steam, the cooking temperature remains constant and the food remains tender. This cooking method not only keeps food heavier, fresher, and juicier; it also saves time. The addition of convection solves the browning dilemma. Adding the convected hot air into the equation introduces enough heat to brown the food item. The main modes of operating the combination oven are steam (vaporized water surrounding the food), convection (circulation of hot air), and a combination of both systems (simultaneous use of vapor and hot air). The appliance is ideal for many culinary applications, including baking, roasting, grilling, steaming, braising, blanching, and poaching (see Figure 2.16).

New Appliance Technologies Combine Heat Transference Methods

Over the past decade or so, major cooking appliance innovations have been introduced that change how appliances work, how efficient appliances perform cooking tasks, and how appliances are controlled. New touch-pad control panels on built-in conventional and microwave ovens add new placement concerns for the kitchen designer, a topic addressed later in this chapter.

Let us first focus on point-of-use or special-purpose appliances available today. These include, for example, built-in gourmet coffee systems, individual specialized cooking elements (wok, deep fryer, or other modular units), and ovens with combination heat transference systems. One of the most impactful innovations has been the combination of heat transfer methods in oven cooking. The most popular combinations are:

- Conventional heat combined with convection cooking in traditional full-size oven cavities.
- Microwave energy combined with conventional heat transference and electric browning elements.
- Steam ovens combined with convection heat transference.

There are no limits on the cookware that can be used when conventional/convection/steam heat transference systems are combined. There are specific recommendations for cookware in an oven cavity that combines microwave/convection/conventional browning elements. Most manufacturers of these types of combination microwave ovens offer some type of multilevel browning pan that has been engineered to provide an excellent surface to facilitate browning and are compatible with microwave cooking. When the cook would like to combine microwave energy with convection energy, there are limits on the cookware that can be used. Manufacturers list the recommended cookware materials in a generic fashion in their use and care manuals. All recommendations are the same: Glass, ceramic glass, or earthenware (pottery or clay) bakeware is ideally suited to cooking when combining microwave

FIGURE 2.16 A steam oven can cook a variety of food products; it is not limited to vegetable preparation.

Courtesy of Miele, Inc.

energy and convection heat transference. While these cookware materials can work in a combination oven, they vary in their desirability as a container to bake in. From a baking standpoint, metal bakeware has always been considered the best because of even browning. However, this is simply not a choice for the microwave/convection oven.

Glass bakeware. Glass conducts heat extremely well. Therefore, it is an excellent baking container. A word of caution: Recipes with a lot of sugar (pound cakes and cookie bars) might start to burn before being cooked all the way through. Glass always has the advantage of being nonreactive: You can store foods in the baking dish without worrying about the food picking up metallic flavors. It is excellent for baking, casseroles, puddings, and other dishes where browning is not of key importance.

Ceramic bakeware. This type of bakeware has the same problem as glass pans regarding browning. The original pyroceramic glass version was introduced in the 1950s as a product usable on a cooking surface as well as in the oven. Current bakeware is no longer pyroceramic; it has been reformulated for cookware that has resulted in a product that is no longer useable on the stovetop. Products available today are only appropriate for use in the oven.

Silicone bakeware. Silicone has great nonstick attributes; however, it is a poor heat conductor, and baked goods tend to brown very little, if at all, when baked in these pans.

Earthenware (pottery and clay). Earthenware bakeware has clay base that is sometimes fired with a ceramic coating. These earthenware products slowly and evenly diffuse the cooking heat to the very center of the cooking dish. Therefore, food is cooked evenly. The products have superior heat retention properties, which keeps food hot when on the dining table or kitchen table. They can go from freezer to oven because of their thermal shock properties. These products should be seasoned prior to their first use.

Heat Sources

The designer has now finally arrived at the factor foremost in most consumers' minds as they talk about a cooking appliance: the decision between a gas and electric heat source.

Natural Gas

Gourmet cooks usually prefer gas because it permits precise control of heat and offers an instant *on/off* feature. Gas appliances feature pilotless ignition systems that eliminate continuously burning pilot lights and save about 30 percent of the gas used by the range when compared with older equipment.

Designers should understand how gas cooking works. Gas is composed of molecules continually in motion. Since a gas tends to expand and diffuse, the molecules completely fill the containing vessel, and their motion is limited only by the size of the enclosed space. They exert equal pressure in all directions. The tendency of gas to diffuse is the fundamental essential for gas flow.

Just as water flows from a higher to a lower level and heat flows from a hotter to a cooler body, gas flows from a place of higher pressure to one of lower pressure.

The heating value of a gas is the amount of heat produced when a unit quantity is burned. It is measured in Btus (British thermal units) per cubic foot. A Btu is a unit of heat energy: the amount of heat required to raise the temperature of 1 pound of water by 1° F. This amount of heat is equal to that produced by burning an ordinary wooden match.

The standard cubic foot of gas, as defined by the American Gas Association, is the quantity contained in one cubic foot of volume at a barometric pressure of 30° of mercury and at a temperature of 60° F.

Gas is regulated by a meter on the house exterior. Gas travels through a pipe from the meter to the appliance. The Btu rating of the appliance determines the diameter of the pipe. The flow of gas is directed by the turning of a valve handle. A horizontal pipe through which gas flows from the fuel line to the different orifices is called the manifold. Attached to the manifold are burner valve handles that direct the gas through the orifice and mixer head into the burner.

Forced through the orifice at velocities of 100 to 160 feet per second, the gas develops sufficient suction to draw air through the partly open shutter. This air, called the primary air, mixes with the gas before it is ignited in a porcelain-lined mixing tube, the smooth finish of which increases the injection of primary air and gives a clean, sharp blue flame.

The gas/air mixture now flows through the ignition port on the side of the burner head. This port is connected to the solid state ignition. The spark that ignites the gas when the burner is turned on is caused by the electric ignition. The electric system also turns the gas off.

Gas cooking appliances incorporate a grate over the flame to allow for the necessary oxygen for correct combustion of the gas.

Gas burners are designed to give a circular flame pattern, the size of which can be controlled, to some degree, by the amount of gas delivered to the burner. The burners usually are controlled by a throttling valve that resembles a rotary switch in appearance. The intensity of the flame can be controlled on a graduated basis from low to high. Some burners are equipped with special simmer units, which are, in effect, a very small burner located in the center of the main burner. Although gas burners differ somewhat in form, the principal parts are the same, and the way the gas is ignited is the same.

Most gas range tops or cooktops today have high-rated Btu burners. In the past, typical residential equipment provided burners at 9,000 to 12,000 Btus. Many appliances are available today that offer 15,000 to 20,000 Btu rated burners. These gas burners have been engineered to provide a very low Btu output for simmering as well.

Many cooks consider natural gas surface cooking to be the most ideal. Electric oven cooking typically is preferred over gas oven cooking. This combination of preferences has led to free-standing ranges that are considered dual *fuel*. The cooking surface is gas and the oven is a pyrolytic self-cleaning electric oven.

Electricity

Alternatively, an electric heat source can be specified. Four types of electric cooktops generally are available for home kitchens today.

Conventional Coil Elements

This is the most inexpensive of all available electric cooktops and has a good heating speed. These cooktops have, for the most part, been replaced with glass ceramic surfaces.

Coil elements are versatile. If equipped with a special raised canning element or a contoured wok element, they will accept large canners or woks. With conventional coils, electrical resistance is used to create heat. Wire is encased in a metallic tube filled with an insulation material. The tube is shaped into a coil and flattened for maximum contact with cooking utensils. Heat travels from the hot coils to the cookware by both conduction (where there is contact) and radiation.

Glass Ceramic Cooktops

Electric resistance coils are located under the smooth glass ceramic top. The heat radiates to the glass surface, where it is transferred to the pot by conduction and some radiation. In order to conduct heat efficiently, contact between the pan bottom and the cooktop must be good. Designs on the cooktop indicate heating areas. Withstanding temperatures to 1300° F (704.44° C) without expanding or contracting, glass ceramics will not warp and are very hard to break. Yellowing of white ceramic surfaces has been eliminated, and elements have been redesigned to achieve faster heating.

In addition to conventional radiant heat, two other technologies are used with glass ceramic cooking surfaces. The first is induction, which was discussed earlier in the chapter. The second is halogen.

Halogen

Halogen range burners combine the elegance of smooth glass ceramic cooktops without giving up cooking performance. Whereas a conventional electric burner gets hot because of electrical

resistance as electricity flows through a nichrome wire, a halogen burner works like an incandescent light bulb. Electricity passes through a tungsten filament inside a quartz-glass tube. Resistance causes the filament to heat up, and, in the process, tungsten particles boil off. Therefore, conventional electric energy is converted into light and heat beneath the glass ceramic surface.

In conventional light bulbs, the tungsten particles settle inside the glass, which darkens it. In a halogen bulb, halogen gas combines with the evaporated tungsten to form tungsten halide. When this compound nears the filament, the heat breaks down and redeposits the tungsten on the filament, so the lamp does not darken and the filament lasts longer. The energy emitted is mostly infrared and wavelength. Therefore, the waves pass readily through the glass ceramic cooktop. About 10 percent of the output is visible light. Consequently, the burner's red glow instantly shines through the translucent cooktop. This allows the cook to know immediately if the burner is on, overcoming a problem with traditional glass-top cooktops.

Solid Disk Elements (Electric Hobs)

Originally from Europe, solid disk elements are popular today because of their sleek lines and cleanability. The cast iron surface, which contains electric resistance wires below, has a non-corrosive coating and is grooved for traction. It is surrounded by a stainless steel spill ring and sealed to the cooktop. With the solid elements, the entire disk becomes hot and conducts heat to the cookware. Since the solid element disk is cast iron, it shares many of the positive qualities of cast iron: gradual heat up and heat retention so cooking can be finished after the power has been turned off.

Two types of solid disk elements are available: the thermostatically controlled version has a central thermostat that senses the temperature of the pan bottom. Controls can be set for a range of temperatures. The second version has a thermal protector or limiter that ensures the long life of the element by preventing overheating when heat is not properly conducted away from the element surface. Regardless of the type of control, solid elements do not glow red. (The temperature of the element does not become high enough to be a fire hazard.) Because the element is a thick plate of metal, the problem of warping is eliminated. Sealing the element into the cooktop eliminates the need for cleaning drip pans or the area underneath. Periodic treatment may be needed to prevent rusting, but generally it is not necessary if the manufacturer's directions for care are followed. Heavy-gauge, flat-bottom metal cookware of the same diameter as the element is recommended.

Thermostatically Controlled Surfaces

Some cooking surfaces on the market have one or more surface units that are thermostatically controlled. This type of element has a central sensitive disk backed by a spring that holds the disk in contact with the bottom of the utensil. The control is connected to the switch or valve handle and operates to maintain the temperature for which the dial is set. Such a controlled burner is equivalent to using a small electric appliance and helps to eliminate scorching of food. Since the action of the thermostat is regulated by the temperature of the center of the pan in contact with the disk, it is good practice to have the food cover the center of the pan. Additionally, utensils used with these thermostatically controlled burners should be made of heavy-gauge material that is a good conductor of heat. The pan must also have a flat bottom.

Methods of Heating

Gas Ovens

The gas oven is heated by a burner, which is beneath the oven floor. The floor plate has openings at the corners or along the sides through which the convection currents rise to circulate throughout the oven. The food in the oven is heated partly by these convection currents and partly by the radiation that occurs once the lining of the oven becomes heated. Gas ovens are available with pyrolytic self-cleaning systems from American manufacturers. Convection systems are also available for gas ovens.

Gas ovens offer pilotless ignition systems, which have eliminated the need for a constantly burning pilot flame. It is estimated that this innovation has saved up to 30 percent of the gas used in residential cooking.

Most gas ovens have broiler drawers below the oven; some appliances have a waist-high broiling element that allows oven broiling.

Electric Ovens

Because electric heat is flameless, the electric heating units are placed within the oven itself, which is of a tight construction. Generally, there is a heating element at the top and another at the bottom of the oven. There may be tubular enclosed or open wiring. The lower unit is usually a single coil, and the top unit will be a single coil, several loops, or two coils. The oven vents through the center of the reflector pan beneath one of the back surface units. Electric ovens are available with pyrolytic self-cleaning and convection cooking systems.

Controlling Gas and Electric Ovens

Temperature in both gas and electric ovens is controlled by a thermostat. However, the thermostatic action is different in gas and electric ovens. For example, if the thermostat in an electric oven has been set for 325° F (162.77° C) and the switch is turned on, the unit will operate until a temperature of about 400° F (204.44° C) is reached. This temperature is known as the preheat overshoot—it allows the door to be opened and cool food to be placed within the oven without losing too much heat. At the end of this preheat period, the electricity cycles off automatically and the temperature drops somewhat lower than the 325° F (162.77° C) setting. The current then turns on again and continues to cycle on and off usually 10° above and below the 325° F (162.77° C) setting.

In a gas oven, there is also a preheat overshoot. However, the gas does not shut off completely; rather the valve partially closes, reducing the flame size to maintain a constant preset temperature. Ranges that feature the low 140° F to 250° F (60° C to 121.11° C) temperature may use the cycling method, but the curves have smaller amplitudes than found in the electric range. Temperature in the food does not cycle but continues to rise until the food is cooked.

Types of Ovens

Convection Ovens

Convected hot air for baking was introduced to the baking industry as a commercial advantage in the 1950s. It was an immediate success, creating considerable savings in energy and time and, offering greater flexibility in baking with a more even bake. Virtually all bakeries and restaurants now use convection ovens, and the convection cooking principle is now widely available for home use in several brands of ovens.

In a convection oven, an element heats the air and a fan then circulates this air evenly throughout the oven cavity. The circulating hot air penetrates food faster than the motionless air in a conventional oven. Therefore, several cooking advantages are offered to the consumer.

The circulating hot air cooks foods evenly and in a shorter period. Eggs and cheese dishes bake higher and lighter. Meats and poultry remain juicy and tender and brown beautifully. Any dish normally baked in a standard oven can be cooked in a convection oven with no special bakeware required. Additionally, several items can be baked at the same time, or the oven can be filled with several trays of the same item because air circulation space need not be so generous around all the foods as in a conventional oven.

On the down side, baking pans and casseroles must have low sides and be uncovered to take advantage of the circulating air. For cooking covered foods, convection ovens offer no time or energy savings.

Clients can convert favorite recipes to take advantage of convection cooking features. Many convection ovens today include an *autoconversion* feature, which allows the cook to enter the temperature and time from a traditional recipe, and the oven makes the conversion. Additionally, convection ovens are available that have a variety of settings, allowing the oven to modify the manner in which the convection fans operate so that convection roasting is programmed to operate differently from convection pastry baking.

Microwave Ovens

Microwave ovens can be freestanding countertop models, built-in models with a trim kit, a combination appliance combining the microwave and a ducted or duct-free ventilation system placed above a cooking service, or a full-size oven that is combined with convection cooking as well as some type of browning ability. The appliance also can be configured as a pullout drawer, designed to be installed below the countertop in a base cabinet enclosure.

In better-designed kitchens today, the microwave is installed as a built-in appliance, as part of a multifunctional oven, or in the drawer configuration. The least desirable configuration is a combination hood/microwave unit placed over a cooking surface. The concern about this installation relates to a safety issue: A child or petite adult will find it awkward—and possibly dangerous—to retrieve hot items from a microwave installed higher than the *NKBA Kitchen & Bathroom Planning Guidelines* recommend.

Oven Cleaning Systems

Pyrolytic System (Self-cleaning)

Pyrolysis is a chemical change brought about by the action of heat. *Heat* is the key word in describing this self-cleaning or pyrolytic oven. In this system, the oven is heated at temperatures ranging from 850° F (454.44° C) to 1000° F (537.78° C). At the end of the completed cycle, after the cool-down period, all that remains of the food soil is a powdery ash that is easily removed with a damp cloth.

To activate the cleaning system, a lever is moved to lock the oven door and two controls are set. An inner lock is provided so the oven door cannot be unlocked when the oven temperature is too high for safety. An electrostatic precipitator usually is included to remove smoke that would otherwise come from the oven vent. However, do warn the clients that they probably will smell an odd odor during the cleaning process. Supporters of the pyrolysis system claim that with this method, all six sides of the oven interior are cleaned completely and no special care is required to prevent scratching or damage to the oven surface. Additionally, the extra insulation provided in these ovens to protect against heat transference from the oven to the adjacent living spaces means cooler cooking throughout the year and less cycling on and off the heating element.

Catalytic System (Continuous Cleaning)

The catalytic system is designed to eliminate the need for cleaning an oven. A catalytic material is mixed into the porcelain enamel coating on the oven liner panels. This material causes a chemical reaction at normal cooking temperatures that oxidizes food soils continuously as they occur during the cooking operation. This method, then, does not require a separate cleaning cycle at high temperatures because the cleaning takes place simultaneously as the food is cooked. Manufacturers using this system emphasize three points:

1. Heavy spillovers will not be cleaned without first wiping up the excess with a damp cloth.
2. Harsh abrasives, chemical oven cleaners, and scouring pads should not be used on excessive soil or stubborn stains.
3. Certain types of food stains may not disappear in one operation but will fade during continuous subsequent use of the oven.

This type of catalytic system is the most commonly specified cooking appliance in Europe. When combined with a true convection oven, the continuous cleaning cycle works in an acceptable fashion. However, when it is not a part of a convection oven, many people find that the oven does not look clean. Advocates of the catalytic approach point out that the oven is never locked during its two to five hour cleaning process; therefore, it is always available to the cook. All that continuous cleaning prevents any buildup of soil, and very little basic redesign of existing ovens is required since high temperatures are not used. This is another reason why this system is employed in European appliances, which are generally smaller than domestically produced ones. If the interior oven size of a European manufacturer model were further reduced because of the extra insulation required for the pyrolysis system, the appliance probably would not be usable.

Major appliance manufacturers are constantly devoting resources to product improvement; therefore, appliance specifications change regularly. Additionally, new innovative appliances are introduced to the kitchen and bathroom industry on a frequent basis. On a regular basis, designers should study manufacturers updated literature, visit manufacturer Web sites, and attend national and local trade shows where new products are introduced to the market.

Primary Cooking Center

The next decision lies in determining which style unit or units will suit the space and cooking needs of the client.

Built-in Equipment Ovens

The family's cooking patterns will direct the recommendation for a single, double, or a combination of single and micro convection equipment.

One of the biggest advantages of built-in oven/cooktop units is that the designer and client have complete freedom and flexibility in placement. The two appliances can be placed side by side or separated to create distinct work cells.

An oven should be placed at a comfortable, accessible level.

Ovens built into a tall tower offer the convenience of one oven at waist height and one below in the case of double ovens.

Some ovens are designed to be placed in the base cabinet so counter space is not lost. An oven should be placed at a comfortable, accessible level. Under-counter installations should be suggested only with ovens engineered for such a location.

Single oven(s) also can be placed in "mid-height" base units, alone or side by side with a second single oven. This design makes the appliance more accessible and maintains a landing space above it. This installation is more expensive than specifying a double oven, which requires only one 220 circuit, but may be the best solution if a client is height challenged or if individuals of varying heights will use the appliance.

Built-in appliances have a higher cost than freestanding ranges, which combine both oven and cooking surface. Additionally, installation fees and electrical wiring requirements will be greater than needed for a single appliance.

Ergonomic Concerns When Locating a Built-in Oven

A planning concern is the wall space required for ovens placed apart from the cooktop. Oven cabinets are 27, 30, or 33 inches wide for single- or double-stack ovens. Placed side by side, ovens can require as much as 66 inches of wall space. The two built-in units also use a minimum of 55 to 60 inches of wall space, which might cramp countertops in a compact kitchen. Last, the interior dimension of most built-in ovens is smaller than a 30-wide-wide freestanding range oven.

Appliance manufacturer specifications guide designers in proper placement off the floor as well as heat concerns related to cabinetry above the oven. Some built-in ovens are designed to be installed flush with the adjacent cabinetry. This is possible because the oven vents are located on the face of the appliance.

Most built-in ovens today have touch-screen technology operating the control panel. This type of screen has largely replaced turn and push knobs. Because of the visual interface required to operate an oven, new concerns have arisen about how high ovens should be installed. *Architectural Graphics Standards* has identified that the sight line of a typical man or woman is 4 inches below their overall height. Ideally, an oven should be placed so that the control panel is at or near this height, allowing the user to see the control panel and easily operate it (see Figures 2.17, 2.18, 2.19, and 2.20).



FIGURE 2.17 Ovens offering various cooking functions installed adjacent to one another makes all units easily accessible.

Courtesy of Miele, Inc.



FIGURE 2.18 Single ovens can be installed next to one another for easy access. Note the placement of warming drawers below the ovens, making these appliances accessible as well.

Courtesy of Sub-Zero and Wolf



FIGURE 2.19 A double oven stacks one appliance above the other. Access to the control panel may be difficult for a petite cook.

Courtesy of Wood-Mode Fine Custom Cabinetry



FIGURE 2.20 Single ovens and a combination microwave/convection oven installed adjacent to one another with warming drawers below.

Courtesy of Jenn-Air

Cooktops/Range Tops

Built-in cooktops come in two configurations. The first is a self-contained surface unit that drops into a cutout in the countertop and is called a *cooktop*. The second popular style is a front-controlled unit, which requires a lowered cabinet height to accommodate the front panel controls and is called a *range top* (see Figure 2.21).

Cooktops come in a wide variety of sizes and configurations. Simple four-burner cooktops often are used in more modest projects. For the serious cook, five- or six-burner range tops often are specified.

The method of ventilating the cooktop must be determined in the early design phase. If a downdraft separate ventilation system is going to be used, the overall depth of the cabinet may need to be increased.



Image copyright © Showplace Wood Products, 2013

FIGURE 2.21 Gas range top with controls at front of appliance
 Courtesy of Showplace Wood Products, Inc.

Slide-in and Freestanding Ranges

Slide-in and freestanding ranges (see Figure 2.22) feature an oven below the cooking surface. These are the least expensive types of ranges and may suit the client's cooking needs, space limitations, and budget. However, they will not add the sleek look of built-in models or the gourmet cooking style of commercial-type freestanding equipment. Regardless of expense, models with the controls along the range's backsplash should be avoided. They are awkward to use and potentially dangerous to the cook.

If the slide-in or freestanding range being considered has the controls along the top and can accommodate a downdraft ventilation system, designers may need to increase the depth of the adjacent cabinetry to accommodate the downdraft appliance.



FIGURE 2.22 Freestanding gas ranges are available in 30-, 36-, 48-, and 60-inch widths.
 Courtesy of Sub-Zero and Wolf

Drop-in Range

The third option is a drop-in range. Although similar in looks and price to the slide-in, this appliance is installed between base cabinets and supported by the range deck or by adjacent cabinetry. A rim provides the transition from range to countertop that helps avoid cleaning problems. Generally, the controls are placed along the front of these 27 to 30 inch wide appliances so they are simple to reach and safe to use.

If the drop-in range will be combined with a downdraft ventilation system, extra cabinets around the range and on each side may need to be planned.

Specialty Appliances

- **Coffeemakers.** Built-in coffeemakers are available in both plumbed and nonplumbed configurations. Engineered to recess into a normal wall thickness, they can provide a coffee station for the consumer without the bulky coffeemaker appliance from sitting on the countertop.
- **Electric fryer cooktop.** An electric fryer cooking module is another specialty cooking appliance. A deep container is an integral part of this unit, into which a series of baskets are used to deep-fry food. Accurate temperature control is essential; therefore, the better units have digital temperature readout to provide complete control.
- **Electric grills.** Individual electric grills can be incorporated under an overhead ventilation system or as part of a combination cooktop vented with a downdraft system. Extra attention must be paid to the ventilation system when planning an integrated grill cooktop. Typically, high-wattage or Btu-rated elements provide heat under a low-profile, one-piece grilling grate. For ease of cleaning, there will be some type of plate or removable tray to accumulate unwanted grease and make removal and disposal easy.
- **Griddle.** Cooktops and range tops with six burners often have an interchangeable griddle available that can take the place of two burners for specialty cooking.
- **Steamer cooktop.** Steamer modules are used to provide temperatures of 140° F (60°C), allowing food to be kept hot for long periods or to defrost easily without drying out or losing the flavor. A typical steamer will have a 2-gallon capacity, which can hold up to 14 cups of cooked food, and will feature a dome lid to maximize the interior space.
- **Warming drawers.** Warming drawers are available in single and double configurations. They may have a decorative door or be concealed to match the cabinetry. Featuring both moist and dry settings, they are used to maintain food at a serving temperature after the product has been cooked. Some homeowners also use them to heat plates.
- **Wok cooking.** Several custom manufacturers offer a built-in wok to augment normal cooktop/range-top cooking. Other manufacturers design their high-rated Btu burners to accommodate a surface wok, ensuring sufficient heat for the quick stir-fry nature of wok cooking.

Ventilation

Please review the material in the Kitchen & Bath Residential Construction and Systems volume of the NKBA Professional Resource Library to familiarize yourself with the basic engineering and mechanical concerns of a well-designed ventilation system.

Once you have considered the categories of equipment available, you should evaluate whether the model you are considering offers the type of ventilation system that will enhance your design.

The designer must be familiar with several ventilation systems:

- **Proximity or downdraft ventilation systems,** allowing design freedom and creativity above and around the cooking surface.
- **Decorative metal or wood** with an integral or a remote located blower.
- **Overhead ventilation systems,** which can be concealed within the cabinets or be a low-profile, pullout hood.
- **Combination microwave and hood appliance.** This combination often does not provide an ideal location for the microwave oven and does not always allow for a proper holding canopy for an effective hood.
- **Mantel or chimney hood,** where a ventilator is housed in a custom enclosure, which acts as a focal point in the space. Again, the motor may be part of the interior structure or

mounted remotely. Designers typically purchase an interior liner, including the ventilator and lighting portion of the system, and surround it with a job-built frame or incorporate it in a prefabricated plasterlike enclosure. This decorative hood may be mounted on brackets returning to the wall or be completely enclosed with a mantel-type extension to the countertop. Providing proper landing space is critical with this type of hood.

Importance of Ventilation

In addition to an overhead hood being beautiful or a downdraft less visible, the system must be engineered, located, and ducted to maximize the efficiency of the appliance. It takes collaboration between the design professional, the appliance specialist, and the heating, ventilation, and air-conditioning (HVAC) technician to properly plan an effective ventilation system. Ventilation experts sometimes talk in terms of *efficacy* rather than *efficiency*.

Difference between “Efficacy” and “Efficiency”

Both “efficacy” and “efficiency” have to do with the quality of work. Efficacy is the more basic concept; it is the quality of the product working as expected, intended, and needed. Efficiency adds the aspect of working in a manner that does not waste time or money or effort.

Here is a simplistic demonstration of the terms: One could achieve efficacy using a 1-inch brush to paint a wall, but one would achieve efficiency by using a bigger brush. When talking about a ventilation system, efficacy would achieve the required movement of air. Efficiency would result in efficacy with less effort, less cost, and less time.

Understanding the home ventilation system starts by knowing how air moves throughout the home. There are three major ventilation systems used in the home:

- Natural ventilation (opening a window).
- Spot ventilation (an exhaust appliance placed above a cooking appliance, behind it, or as an integral part of the cooking surface).
 1. An overhead system can be engineered with a canopy or perimetric hood to capture and remove vapors.
 2. A proximity system (downdraft or telescoping) can be integral to the cooking surface or a separate appliance placed behind the cooking surface.

All systems can be engineered to duct to the exterior or can be duct-free.
- Whole-house ventilation (systems designed to exhaust stale air and/or supply fresh air to the entire dwelling).

The Focus for Kitchen Designers: Spot Ventilation

If a traditional canopy-type overhead vent is specified (see Figure 2.23), airborne vapors will rise naturally (see Figure 2.24) into a capture area of the canopy. The internal blower then pulls them out from the capture area and exhausts the air to the outside.

Spot Ventilation

This type of a kitchen ventilation system is an enclosure designed to capture and vent unwanted and unhealthy heat, odors, gases, grease, steam, and smoke. The ventilation system's internal (or externally located) fan must effectively capture a column of air containing vapors, steam, and smoke directly over or around the cooking surface and exhaust them to the outside of the home or scrub them through a filter system.



FIGURE 2.23 Canopy hood above a 30-inch range installed against a wall
Courtesy of GE Appliances



FIGURE 2.24 A canopy hood installed above an island can be compromised because of air current.
Courtesy of GE Appliances



FIGURE 2.25 A telescoping downdraft system installed behind a cooking surface

Courtesy of Jenn-Air

If a proximity vent is specified, the ventilation system will pull airborne particulates from the surface (like a vacuum) and exhaust them down and to the outside (see Figures 2.25 and 2.26).

A new choice is available today based on a new way of moving air, called *perimetric* (see Figures 2.27, 2.28, and 2.29.) Airborne particulates are pulled through narrow slots along the edge (the perimeter) of a center panel into an enclosed space. The internal blower then exhausts them to the outside.



FIGURE 2.26 A proximity ventilation system built into the cooking surface.

Courtesy of Jenn-Air



FIGURE 2.27 A demonstration of the efficiency of a perimetric ventilation system.

Courtesy of BEST Range Hood, LLC



FIGURE 2.28 A telescoping downdraft appliance is also available with perimetric ventilation engineering.

Courtesy of Jenn-Air

The Difference between “Parameter” and “Perimeter”

Some of these new hoods are referred to as *parametric*. The terms “parameter” and “perimeter” do not have the same meaning; they are not interchangeable. Nor are the adjectives “parametric” and “perimetric,” interchangeable. The next explanation might help clarify the difference.

Usage: Until recently, use of the word “parameter” was confined to mathematics and related technical fields. Since about the mid-twentieth century, however, it has been used in nontechnical fields for “a limit or boundary,” as in “They set the parameters of the debate.”

This use, probably influenced by the word “perimeter,” has been criticized for being a weakening of the technical sense. As a loose synonym for “limit,” “boundary,” “guideline,” and “framework,” it blurs more than it clarifies. Careful writers will leave the word “parameter” to specialists in mathematics, computer science, and other technical disciplines. “Perimeter” is a different word, meaning “border, outer boundary, or the length of such a boundary.” Therefore, it is the correct descriptor to use in a ventilation discussion.



FIGURE 2.29 A perimetric ventilation system can transform the hood into a sculptural design element.
Courtesy of BEST Range Hood LLC

Ventilation System Selection Criteria

There are four key components to be considered when selecting a ventilation system:

- 1. Duct path.** Improper ducting diminishes the efficiency of the system. A layout for the ductwork that follows all of the guidelines set forth by ventilation manufacturers regarding length of run and number of allowable turns should be prepared before a system is specified.
- 2. Hood width and depth.** The shape of the appliance and its placement determine the capture ability of the system.
The Home Ventilating Institute (HVI) stresses that the width and depth of the canopy-type hood dramatically impacts its efficacy (how well the hood does its job) for serious cooks. While a 30-inch-wide hood above a 30-inch-wide range will work, if space permits, HVI recommends extending the hood 3 inches on each side of the cooking surface. This will provide the best possible capture of steam, grease, and smoke.
- 3. System power,** which is rated in CFMs (cubic feet of air removed per minute). The required power level is determined by the heat generated by the cooking appliance, the type of heat source, and the anticipated type and frequency of cooking.
- 4. Operational noise level,** measured in sones. The smaller the sone number, the quieter the noise level.

To provide an efficient ventilation system, these four key components must be planned together during the preliminary design stage of a kitchen project.

Ergonomic Considerations: Pairing the Ventilation with the Cook's Height

Additional considerations should be given for a ventilation system installed above a peninsula or an island. A design dilemma occurs when planning an island installation for a tall or petite cook. Placing the ventilation system low enough to maximize its efficacy means it may block the user's view. Raising it up may decrease its efficacy. Although ventilation system placement is of primary concern in an island installation, it is also a concern when a hood is placed against the wall. Always check the manufacturer's specifications for the required installation height.

Proximity Ventilation System

A proximity ventilation system—where the ventilation technology is near the cooking surface—is an alternative to an overhead hood.

The first type of proximity ventilation was introduced in the early 1960s. The downdraft ventilation unit was an integral part of the cooktop. This system then evolved into a separate downdraft ventilation unit installed behind the cooktop, called a *telescoping* system because it extends up from the counter when in use.

This type of ventilation allows for an open plan in the kitchen: a style that continues to be popular today with active extended families and aspiring (or inspiring!) gourmet cooks interacting in the kitchen.

Proximity ventilation captures the vapors in the zone around the cooking surface and vents them to the exterior of the house or through a filtered system and then back into the room.

Duct-free Downdraft System

One new innovation is a duct-free downdraft cooktop system that uses a HAPA (high airflow particulate air) filter. This is a great solution when planning a room that has installation restrictions or ducting limitations. The HAPA filter captures smoke, grease, and moisture while allowing air to travel through the filter without loss of efficiency. The clean air is vented through the cabinet toe-kick space back into the room. The filter has an indicator light alerting the user when it needs to be replaced. Because this system takes up the majority of the interior cabinet space, designers need to plan additional storage for pots and pans. Designers also must review state and local municipality ventilation codes: Some codes do not allow any residential duct-free systems.

Telescoping Downdraft System: Behind the Cooking Surface or Range

In the second type of proximity system the unit is placed behind the cooking surface. Depending on the depth of cabinetry used, you may need to pull them from the wall or plan for

deeper cabinets. Extra depth in the layout design will be required if a telescoping system is planned behind a range.

Perimetric Suction Filter System (Perimetric Advanced Extraction Technology)

The perimetric suction filter system is a new ventilation system that has been introduced into the North American market. In it, air is drawn into the range hood through *collector slots* along the perimeter of a central deflector panel. Therefore, it is referred to as a *perimetric* or *perimeter* hood.

The perimetric panel design decreases the space for air to flow through, which increases static air pressure. This results in an increase in the overall velocity of the air movement.

This is a very different way to move air from the traditional ventilation system, which has a larger holding cavity to catch airborne cooking vapors until the internal or external fan has time to push/pull them over the filtering system.

By shaping the air flow, a perimetric suction hood offers improved overall performance (increased suction at the sides of the unit) compared to a traditional mesh filter, where most of the function is concentrated in the center of the canopy holding area and then drops off rapidly toward the sides.

It is important to understand that the performance of a perimetric hood is measured in CFMs, just like a traditional ventilation system. This new system does not offer more power for less CFMs; it just moves the air in a different way.

Importance of a CFM Rating for Ventilation Systems

The CFM rating—that is, cubic feet of air per minute that is whisked away by the ventilation system—is the third part of the system engineering puzzle. Guidelines are not consistent for a cooking surface placed against a wall.

- The minimum code-required exhaust rate for a ducted hood is 100 CFM ducted to the outside.
- The HVI recommends a minimum of 40 CFM for every linear foot of the range.
- *NKBA Kitchen & Bathroom Planning Guidelines* recommend a minimum of 150 CFM ducted to the outside.

These minimums are not adequate for many installations.

HVI's CFM Rating Guidelines

For best results, successful designers follow the recommendations from HVI in Table 2.2. The HVI recommends increasing the CFM levels over high-powered gas cooking surfaces.

Many gourmet cooks feel the best cooking appliance is a gas unit with highly rated, powerful Btu burners. Such an appliance needs to be coupled with the proper, powerful ventilation system.

A large overhead canopy hood that is at least the size of the range top or range (preferably 3 to 6 inches wider on each side) with a deep canopy holding area is required. It is not just for the cooking—it is for the gas particles escaping into the atmosphere. Gas ranges are typically about 50 percent efficient; that means that 50 percent of the gas emitted by the burners enters the ambient air stream.

The ventilation system needs to capture and exhaust these gaseous particulates.

Some manufacturers have ventilation recommendations for their ranges, but many do not. Minimum code standards never address this issue. Table 2.3 gives the HVI's recommendations.

TABLE 2.2 HVI CFM Rating Guidelines

| Width of hood: | HVI recommended rate | |
|----------------------|----------------------|----------------|
| | Against a wall | Over an island |
| 2.5 feet (30 inches) | 250 CFM | 375 CFM |
| 3 feet (30 inches) | 300 CFM | 450 CFM |
| 4 feet (48 inches) | 400 CFM | 600 CFM |

TABLE 2.3 HVI Recommendations for Ventilation

| | Btus | Recommendations |
|---|---------------|---|
| Gas burner output | < 60,000 Btus | 100 CFMs per linear foot of cooking surface length |
| Gas burner output | > 60,000 Btus | 1 CFM per 100 Btu of cooktop outlet |
| When a grill, griddle, wok, or fry basket is used | | Add 200 CFMs to the estimated base need calculated on the Btu outlet of the cooking surface |

A New Requirement for the Ventilation System: Planning for “Make-up Air”

Pulling air from the kitchen lowers the air pressure inside the home. Today, newly constructed homes are very airtight. Therefore, building code regulations are being adopted to prevent dangerous *backdrafting*—when the flow of combustion gases can be reversed and be pulled into the house (rather than exiting) because of this lower pressure. The solution is referred to as *make-up air*.

The 2009 International Residential Code (IRC) began requiring the introduction of make-up air when kitchen exhaust equipment capacity exceeds 400 CFMs. This code is implemented at the state level; therefore, designers need to familiar with such requirements in their specific business area. Although the 2009 IRC requires make-up air for large exhaust systems, it provides almost no guidance for how it is to be provided. The main installation requirement states that a fan shall be “automatically controlled to start and operate simultaneously with the exhaust system.” This leaves it up to the designer or builder to specify an appropriate type of make-up air system. Further, proper installation of the system is important to avoid hazardous conditions and unnecessary construction costs.

Appliance manufacturers are introducing make-up air dampers designed to operate in tandem with their ventilation appliance offering. There are two systems currently in use.

Active systems may use a sensor to detect air movement in a range hood air duct to open the damper. Other systems open the damper and activate the make-up system at the same instant the hood is activated. In both cases: the user does not “start” the system: the hood starts the process: the hood switch and the make-up air system switch are the same.

Here is how an active system works:

- The damper is intended to prevent any outdoor air from entering the house when the exhaust system is not in operation. The automatic control is accomplished with an electrical circuit involving an air current-sensing relay.
- The current-sensing relay senses when the exhaust fan is operating. It allows a signal to pass through and open the motorized damper. When the fan is turned off, the circuit is closed and the signal is removed from the damper.

Passive systems, using no electricity, operate by a drop of air pressure in the home. When the high CFM hood is activated the home will generally have a drop in air pressure. When that happens, a vent will open allowing outside air into the home automatically. When the hood is turned off, the air pressure returns to normal and the vent closes.

It is important to note none of these systems is integrated into the conditioned air systems for the home. Therefore, when the damper is in an open position: exterior air at the temperature outside enters the house. If a make-up air system is requested that ties into the AC or heating system: designers should call in an HVAC specialist.

A Good Hood Is a Quiet Hood: The Importance of Sones

The word “sones” is an internationally recognized unit of loudness, which simplifies reporting of sound output. Sones translate laboratory decimal readings into numbers that correspond to the way people sense loudness. (To give you a reference, an average quiet refrigerator operates at 1 sone; a normal conversation is between 6 and 7 sones.)

The design of the hood fan and its placement in the system has a lot to do with its sone rating. Designers should experience—that is, hear—a fan in operation to understand its noise level.

Newer designs (see Figures 2.30 and 2.31) involve insulating the motor, changing its position within the hood's structure, or better managing how air moves through the system, all of which can result in a quieter hood.

Appliance Checklist

Use the Appliance Checklist (Appendix B) as you complete the final specifications for each kitchen project you work on. It will help you estimate and specify all the planning details of appliance placement.



FIGURE 2.30 A decorative custom hood

Design by Joseph Irons, CGR, GMB, CAPS, CGP, and Terence Tung, CKD



FIGURE 2.31 Another example of a decorative hood creating a focal point in the finished kitchen.

Courtesy of Artcraft Kitchens

SUMMARY

For many consumers, the appliances selected for their new kitchen are the most important part of the decision-making process. Kitchen designers need to be familiar with how kitchen appliances work as well as how they should be used and maintained. With the generic foundation provided in this chapter, designers can research and evaluate specific offerings by the manufacturers they have chosen to represent within their business or recommend to clients securing the appliances from another source.

It is important for designers to remember that some clients are interested in a new appliance that simply does the functions they are accustomed to better. This might be, for example, a gas range that has a better-designed gas burner offering more power when needed, as well as a very low simmer. Alternatively, prospective clients may be interested in appliances that complete their assigned task in new and different ways. For example, a client might have had a gas range in the past but would be very impressed by the efficiency and safety possible with an induction range top.

Often consumers think they know what new appliances they are interested in. Successful designers listen carefully to the consumer's want list or wish list, and then, after a careful survey of the family's lifestyle and the cook's methods, offer alternative solutions in the type of appliance or the configuration of the appliance.

REVIEW QUESTIONS

1. Explain the difference between an EnergyGuide label and an Energy Star label. What do these two labels tell the consumer? (See "EnergyGuide and Energy Star Labels" pages 92–93)

2. Describe how a food preservation appliance manages temperature and humidity in the refrigerator to extend food shelf life. (See "Method of Cooling" pages 96–97)
3. How does a dishwasher provide proper water temperature to complete the washing action? (See "Length of the Washing/Drying Cycle" page 106)
4. What is the difference between how heat is transferred in the following methods of cooking? (See "Methods of Heat Transference" pages 108–115)
 - A. Conduction
 - B. Convection
 - C. Radiation
 - D. Induction
 - E. Microwave
 - F. Steam
5. Describe the difference between a pyrolytic and a catalytic self-cleaning oven. (See "Oven Cleaning Systems" page 120)
6. Compare the efficiency of an open gas flame to a conventional electric coil under a ceramic glass top and an induction cooktop. (See "Advantages of Induction Cooking" pages 112–113)
7. What are the differences among an overhead canopy hood, a proximity ventilation system, and a parametric ventilation system? (See "Ventilation" pages 125–130)
8. Explain the following terms:
 - A. Btu (See "Natural Gas" page 116)
 - B. CFM (See "Importance of a CFM Rating for All Ventilation Systems" page 132)
 - C. Sone (See "A Good Hood is a Quiet Hood" pages 133–134)

Fixture Materials



With modern-day technology and manufacturing system innovations, a wide variety of materials are used to construct fixtures used in a residential kitchen or bathroom. The choices vary in price, which are typically based on product quality and durability differences. The kitchen or bathroom designer should be familiar with the manufacturing or the fabrication systems used by the companies they represent to create their products. Because products fabricated out of new materials or manufactured in new ways are continuously being introduced to the marketplace, designers should plan a continuing education project by attending trade organization meetings and exhibitions, by using the Internet to learn about new products, and by meeting with manufacturers or their representatives on a regular basis. With this knowledge, the specifier is more capable of sorting through the various options available and matching the right material for the intended use by the homeowner.

To introduce you to the most popular materials and construction methods used to manufacture fixtures, we have listed the widely used choices in alphabetical order. There is an ever-changing collection of special materials available for unique, one-of-a-kind fixtures today—notably for lavatories. Unique bathing pools/bathtubs are also available. To learn more about these special fixture materials, collaborate with your manufacturing representative and/or manufacturing companies.

Learning Objective 1: Describe the different materials that kitchen and bathroom fixtures are made of, comparing their durability attributes.

Learning Objective 2: Provide examples of specialty materials used for bathroom lavatories.

Learning Objective 3: Identify which materials are most appropriate for sanitary fixtures, such as toilets and lavatories.

PROTECTING MATERIALS FROM BACTERIA

Kitchen and bathroom materials can be protected from bacteria by applying a protective coating on the surface or by including an antimicrobial agent (typically silver or copper) within the material itself. The antimicrobial treatments protect against the growth of microbes, such as bacteria, mold, fungi, and algae, by piercing the thin cellular walls of the microbe. Kitchen

Definitions of Terms

Accessory. Although some accessories are specified for kitchens, they are an integral part of bathroom planning. Towel bars, handrails, toilet paper holders, and various other items that complement the fixtures and fittings are an important part of each bathroom center of activity. Their design and placement are detailed in the *Bath Planning* volume of the NKBA Professional Resource Library.

Fixture. A kitchen sink, bathtub, shower, lavatory (bathroom sink), toilet (water closet), bidet, or urinal that receives water.

Fitting. A faucet, bathtub filler spout, showerhead, body spray, body mist, or other finished piece through which water passes and then enters a fixture. For simplicity, we will use the word “fitting” to refer to all types of water-delivering devices.

Your company may have specific terminology policies. Ask how you should refer to the various fixtures in your specifications. When speaking with a client, use terms that are familiar to the average homeowner, or explain a new name to the client the first time you use it.

and bathroom equipment and surfacing manufacturers typically list the presence of such antimicrobial systems within their product literature.

FIXTURE CONSTRUCTION

Cast Iron

You may have heard the term “cast iron” but not know what the term really means. Cast iron actually describes a manufacturing process used for more than a century to produce bathtubs (see Figure 3.1) and kitchen sinks. Molten iron is *cast* in a sand mold.



FIGURE 3.1 Cast iron alcove bathtub
Courtesy of Kohler Co.

Sand is used to shape the cavity of the mold. Molten iron that has been heated to 2700° F (1482° C) is then poured into a channel, filling the cavity. After the molten iron has cooled and solidified, the sand cast is removed (the sand is recycled), and the exposed product is ready for finishing. The exterior surface must be smoothed to a uniform finish. Once this is done, the final enamel finish coat is added. This finish is a combination of clay, frit, color oxides, and opacifiers. It is applied to the exposed surfaces of the fixture in powder form and then fired at 1250° F (676.67), which melts the powder uniformly into a smooth coating, which fuses to the cast iron base material.

In contrast to an enameled steel fixture, the enamel coating on iron is much thicker and the cast iron is more resistant to movement. Therefore, a cast iron product is more chip-resistant.

Heat Transference

Cast iron fixtures are cool to the touch and thus may be momentarily uncomfortable for the bather as he/she reclines against the backrest above the water line. Because cast iron conducts heat, the bath water will cool more rapidly in a cast iron bathtub than it will in one made out of a plastic material, which has better insulating properties.

Weight Factor

Kitchen sinks and bathroom lavatories are heavy but can be carried by one person. Cast iron bathtubs are very heavy and therefore generally are limited to sizes up to 72 by 36 inches and 60 by 42 inches. Attention to this weight factor is important if you are designing a bathroom that is accessible only up a long flight of stairs. It can easily require four strong men to wrestle a cast iron bathtub up to a second-floor location. Check the manufacturer's specifications to verify the exact weight of the fixture, and verify clearances to ensure the bathtub can be moved into the bathroom.

Composite

The use of composite kitchen sinks as pictured in Figure 3.2 is growing rapidly. However, because there are many types of composite sinks, there is much confusion in differentiating one from another. In general, the main types are acrylic/polyester, granite, and quartz composite.

Acrylic/polyester. Of all the types of composite sinks available, acrylic/polyester sinks are the lowest performing in terms of scratch and stain resistance, because they are made from soft materials that can cut and nick easily. Yet they are popular because they come in a variety of colors. They also can be integrated into counter surfaces of the same material in matching or contrasting materials.



FIGURE 3.2 A composite kitchen sink
 Courtesy of Elkay Manufacturing
 Company

Granite composite. The most scratch-resistant sink material on the market today is *granite* composite. They are fabricated with up to 85 percent natural granite particulates. These sinks offer stain, chemical, and scratch resistance. They also offer the highest level of durability because of the extremely high density of rock particles at the sink's surface. Granite-based sinks are available only in matte finishes.

Quartz composite. With a combination of up to 85 percent quartz and the balance resin filler, quartz composite sinks provide a durable surface. These sinks can resist everyday cuts, scuffs, and dents and can easily stand up to harsh cleaning materials or liquids that might stain other sinks. Quartz composite sinks are available in a variety of colors. Because the color is uniform throughout, the material never loses its original color. As with granite sinks, quartz sinks are available in a matte finish only.

Enameled Steel

Bathtubs and lavatories can be constructed out of enameled steel. This material is fabricated by forming cold steel, then applying a coating of enamel, and finally firing the finished piece in an oven.

To fabricate an enameled steel fixture, a sheet of metal is pressed into a die so it forms the desired shape. This process is called "drawing" because it results in a shape that has depth. The fixture is also subject to mechanical operations, called "stamping," to cut or form the individual parts of the fixture. Some enameled steel fixtures also require sections to be welded together.

After the form and shape have been finalized, an enamel coating is sprayed onto the fixture. It is then fired in a furnace.

In the showroom, an enameled steel fixture looks quite similar to a cast iron one. However, there are dramatic differences between these two types of fixtures. Enameled steel fixtures are more susceptible to damage than some other fixture materials because when an object is dropped on the fixture, the smooth formed steel will flex on impact. Because of the smooth nature of the enameled finish, it does not follow the movement of the steel and may therefore chip. Such fixtures also require a stainless rim for mounting purposes.

Enameled steel bathtubs are also noisy and good heat conductors, causing bathwater to cool quickly. On the plus side, they are the least expensive fixture you can specify, and they are easy to handle because of their light weight.

Proprietary Materials

In an effort to both maintain the weight benefits and the cost savings of enameled steel fixtures and overcome the material's susceptibility to damage, major manufacturers have introduced proprietary fixture materials over the last several years. These special materials combine various layers of structural composite backing products (an enamel-grade metal and high-quality porcelain enamel) to provide a lightweight but durable fixture. Pioneered by American Standard 20 years ago as *Americast*, the manufacturing process forms the layered material in a closed mold manufacturing process similar to an enameled steel manufacturing system but results in a more durable product for the bath because of increased shock resistance. This system is also used for kitchen sinks.

To learn more about the benefits of these special products, read the manufacturer's literature or consult with a company representative.

Fire Clay

Fire clay is a compound ceramic material that includes prefired clay particles mixed with ball and china clays. The prefired clay particles (called "grog") are ground into small grains and added to the liquid casting slip, giving it a unique and distinct appearance. Up to 40 percent of the slip can be prefired particles that allow the fired product to be more porous. This extra porosity requires that the fixture have an undercoating applied to the surface before glazing.



FIGURE 3.3 Fire clay kitchen sink designs
Courtesy of ROHL

This extra step in the glazing process gives the finish a deeper color throughout the piece. Fire clay colors—notably white—are typically more brilliant than the colors of cast iron products. The porosity also makes the fire clay more resistant to shock than vitreous ware; therefore, its durability characteristics are similar to cast iron.

Last, fire clay products, as pictured in Figure 3.3, are distinctly different from cast iron in that they are lighter in weight. One of the advantages of the lighter-weight material and less shrinkage in fire clay is that considerably larger pieces can be manufactured with less warpage and crisper design details. However, the porosity makes fire clay products non-code compliant for toilets and urinals—all surfaces containing water must be glazed.

Plastics

Novice bathroom designers often are confused by all the terms that relate to bathroom fixtures made from man-made materials. Some fixtures are identified by the reinforcing material used: fiberglass. Other fixtures are identified by the exterior finish material used: acrylic. Still others are identified by the manufacturing process employed to fabricate the fixture: injection molded.

To understand the differences among these fixtures, you must understand the differences between a reinforcing material and a finishing one. In addition, you should be familiar with the different attributes of each of the popular finishing materials.

Regardless of durability differences, all plastic fixtures are warm to the touch and therefore are comfortable for the bather to lean against. When used for a bathtub, these fixture materials act as insulators so the water in the bathtub does not cool as rapidly as it does in a cast iron bathtub.



FIGURE 3.4 An array of shapes, configurations, and sizes is available in acrylic bathtubs, including jetted versions.

Courtesy of Americh

Acrylic

The first manufacturing approach is to create the fixture by forming it out of $\frac{1}{8}$ to $\frac{1}{10}$ inch sheet of acrylic or acrylonitrile-butadiene styrene (ABS). In this thermo-forming method, the temperature of a thermoplastic material, such as acrylic or ABS, is elevated to a level that makes it pliable and workable; it is then vacuum formed onto a mold, creating the desired shape. All fixtures requiring structural support are sprayed with resin and chopped strands of glass in much the same manner as the fiberglass spray-up method of construction detailed next under “Fiberglass.” The application of reinforcement boards or braces is the same for both materials.

Acrylic and ABS thermal plastics are harder materials than fiberglass-backed polyester gel coated fixtures and the color goes all the way through the material. They also offer deeper color tones and are more resistant to abrasion, high-heat scarring, and sun fading than fiberglass. Although acrylic can be scratched, it is repairable. As you might expect, acrylic fixtures are also more expensive than fixtures finished with a gel coat (see Figures 3.4, 3.5, and 3.6)

Fiberglass

The term “fiberglass” is used in regard to the backing material used to reinforce a polyester gel coat finishing surface. A mold receives a layer of gel coat, then fiberglass strands immersed in a polyester resin are sprayed on or placed on top of the mold in mat form. Additional reinforcing, in the form of wood or metal strips or braces, is attached at this stage of the manufacturing process.

The polyester gel coat is not as durable as other finish surface layering materials in use today. However, it is generally the least expensive finish and the easiest of the plastic fixtures to repair. Much like cultured marble (cast polymer) products, such fixtures are widely produced by small factories. Therefore, quality levels can vary widely.

Injection Molding

Injection molding is the third method of manufacturing plastic fixtures. The plastic material is heated until it reaches a liquid state, at which time it is injected into the cavity of a mold. With this process, the color you see on the surface goes all the way through the material.

Solid Surfacing

Solid surfacing materials are excellent products for bathroom wall panels and countertops, molded one-piece lavatories, and custom-shaped shower pans as well as kitchen sinks and countertops as shown in Figure 3.7. Freestanding bathtubs are also available in solid surface.



FIGURE 3.5 An acrylic bathtub under-mounted in a platform

Courtesy of TOTO® USA, design by Ellen Cheever, CMKBD, ASID, CAPS



FIGURE 3.6 An acrylic shower pan

Courtesy of American Standard



FIGURE 3.7 A solid surface kitchen sink integrated into the DuPont Corian® countertop.

Design by Pietro A. Giorgi, Sr., CMKBD, and Ellen Cheever, CMKBD, ASID, CAPS

Manufactured from acrylic, polyester, or a combination of acrylic and polyester base materials, these homogeneous (color all the way through) materials can be machined by a skilled fabricator and are repairable if damaged. The hard, nonporous surfaces are stain and burn resistant.

There are differences between acrylic-based and polyester-based materials. A more detailed discussion of solid surfacing can be found in Chapter 7.

Stainless Steel

Stainless steel fixtures generally are formed following the same process described for enameled steel fixtures. However, no surface coating is applied to a stainless steel fixture.

Stainless steel quality generally is judged by the steel gauge, the nickel content of the fixture, and the finishing technique.

The higher the gauge number, the thinner the steel.

- A 22-gauge, mirrorlike stainless steel sink is the least expensive and the least desirable stainless steel product. Because of its thinness, it will dent easily, and its mirror finish will show scratches.
- A 20-gauge brush finished stainless steel sink that has a high nickel content will resist water spotting and conceal fine scratches within the brush finish and is thick enough to resist dents.
- The most durable stainless steel sink is an 18-gauge, brushed finish, high-nickel-content sink that has an undercoating on the backside to control noise transmission. Figure 3.8 shows a top-mounted installation and Figure 3.9 shows under-mounted installations.



FIGURE 3.8 A top-mounted (above-the-counter surface) stainless steel sink. *Courtesy of American Standard*



a. Courtesy of American Standard



b. Courtesy of Elkay Manufacturing Company

FIGURE 3.9 A variety of under-mounted (below-the-counter-surface) stainless steel kitchen sink configurations.



c. Courtesy of Elkay Manufacturing Company



d. Courtesy of Elkay Manufacturing Company

FIGURE 3.9 (Continued)

Vitreous China

Vitreous china is used in the manufacture of lavatories, toilets, bidets, and urinals (see Figure 3.10). It is composed of ceramic materials fired to form a nonporous body; exposed surfaces are coated with a ceramic glaze fused to the body. Vitreous china is used for lavatories and toilets because of its formability and sanitary characteristics. Vitreous china has less than $\frac{1}{2}$ of 1 percent moisture absorption compared to other types of ceramics, such as wall tile, which may have as much as 10 percent moisture absorption.

Molded Product

Vitreous china fixtures are a pottery product. To begin the manufacturing process, flint, feldspar, and water are mixed with different types of clays. Once combined, the mixture is poured into a plaster of Paris mold, where it remains during the curing process. The mold is cast from a master mold, which is reused. These molds consist of two sections that form the inside and outside profile of the piece. In solid casting, the mixture is poured into the area between



FIGURE 3.10 Vitreous china is used to manufacture toilets, lavatory sinks, and pedestal sinks.

Courtesy of American Standard

these mold sections. This mixture, called a slip, then conforms to the interior profile of the mold. For thicker elements of vitreous china fixtures, such as the rim of a pedestal lavatory, an alternative method called drain casting is used. This permits the forming of a hollow section without the use of an interior mold.

Quality Standards

When the fixture is removed from the mold, it is inspected for imperfections. Different manufacturers have different definitions of acceptable quality. Generally, it pays to stay with reputable brands and deal only with firms that have a good reputation for quality.

The number of times a plaster of Paris mold is used affects the incidence of imperfections in the fixture. To maintain a high-quality product, first-class manufacturers use the molds fewer times. Some fixture imperfections are repairable. Others are not, and fixtures with these types of imperfections must be destroyed. Therefore, an unacceptable flaw in the tank of a one-piece unit require destruction of the entire fixture. This is one reason why these fixtures cost more than two-piece toilets.

Glaze

After a fixture passes inspection, a glaze is applied. The fixture is fired in a kiln for an average of 24 hours at temperatures reaching up to 2250° F (1232° C). Once the fixture is removed from the kiln, it is inspected again for imperfections in the glaze surface. Fixtures that meet all standards are boxed and shipped.

Decorated Vitreous China

Some vitreous china fixtures are enhanced with the application of a decorative decal, the addition of striping in a precious metal, or the application of an accent color and/or pattern as seen in Figure 3.11. A decal or decorative striping is applied after the china fixture has been glazed and fired. The fixture is then fired a second time. If this additional firing is at 800° F (426° C), the decoration is *on-glaze*. If the firing is at a higher temperature, the decoration is *in-glaze*. A fixture with an *on-glaze* decorative detail will require more care than a typical fixture. To determine just how careful your client must be when using or cleaning the fixture, find out at what temperature the final firing took place.

Wood–Natural

Several manufacturers offer wood bathtubs and lavatories. Wood fixtures generally are constructed from solid strips of oak or teak. Teakwood is considered more desirable than any other species because of its oily composition, which minimizes its expansion and contraction properties. This is why teak is used extensively in marine applications.



FIGURE 3.11 Decorated vitreous china fixtures add a touch of elegance to guest bathroom spaces. *Courtesy of Kohler Co.*

Once constructed, the fixtures are finished with a polyethylene coating to protect and enhance the beauty of the wood. To add to the structural integrity of the fixtures as well as to aid in heat retention, the outside of wood bathtubs is generally sheathed in fiberglass.

Wood fixtures should not be exposed to constant, direct sunlight. They need to be wiped down after each use to avoid the development of a permanent, unattractive water line. If damaged, the polyethylene finish can be repaired.

Specialty Materials

Specialized fixtures are also available in spun glass, plastic products, copper, and brass. When specifying these one-of-a-kind items, your product research for these unique designs, typically proprietary, should focus on the manufacturer's information on sizing, material composition, plumbing/hook-up requirements, and use and care instructions.

Lavatories

Hand painted. Many vitreous china lavatories (below counter, above counter, and pedestal) are part of an artist's collection that has a beautifully rendered hand-painted pattern.

Glass. Glass lavatories in various sizes are cast by space-age glass products to create unique vessel or over-the-vanity type of lavatories (see Figure 3.12). Glass lavatories begin by bringing



FIGURE 3.12 Glass vessel lavatories are available in a variety of shapes and forms.

Courtesy of Kohler Co.

the material to temperatures as high as 2200° F (1204° C) so that the molten glass can be manipulated. The glass can be spun or cast. To increase the durability of the product, layers of metallic oxides, such as titanium, silicone, and magnesium, are layered between two sheets of glass, which is then fused into a flat sheet. These unique lavatories are then placed over a mold and heated to the final shape. Because each of these bowls is handcrafted by artists, there will be slight variations in color, layout, texture, and finish.

Metal finishes. An innovative range of sculptural bathroom shapes is available from several manufacturers in copper, stainless steel, or other specialty metals. Some of these lavatories have what is called a “living” finish and will require constant cleaning; the finish also may change with age. Other metal lavatories are coated so that the original finish protected and will not change if cared for properly.

Figure 3.13a and b shows how unusual materials such as stone can be specified for bathroom lavatories.



FIGURE 3.13a and b NKBA Design Competition award winning powder rooms featuring unusual materials (a.) Design by Lori W. Carroll, ASID, IIDA; codesigners Debra Gelety, Allied ASID, EDAC, and Mary M. Roles. Photo by William Lesch @Lesch Photography



(b) Design by Sol Quintana Wagoner; codesigners John Kavan, Vanessa Tejera. Photo by PreviewFirst.

FIGURE 3.13 (Continued)

Stone—Natural

Granite or marble slabs may be used to create custom one-of-a-kind lavatories, as seen in Figure 3.13. Typically, these natural stone products are reserved for wall, counter, or floor surfacing in a slab or tile format.

A detailed discussion of surfacing materials and their application is found in Chapter 7.

SUMMARY

The materials used in the manufacturing of fixtures have not dramatically changed over the past five years. The biggest growth in consumer interest is in the specification of composite materials for kitchen sinks and an interest in decorative specialty materials for bathroom lavatories.

Although the basic material categories have not changed, less expensive imported products have gained distribution within North America. Sometimes these products are not as durable as offerings by well-known North American and international manufacturers. Designers can use this information as a generic platform of knowledge as they evaluate new products offered in these various material categories.

REVIEW QUESTIONS

1. What is the difference between a fixture and a fitting? (See "Definition of Terms," pages 137–138)
2. Identify the two ways a surface can be protected from bacteria growth. (See "Protecting Materials from Bacteria," page 138)
3. What are the durability differences among cast iron, enameled steel, and fire clay kitchen sinks? (See "Fixture Construction," pages 138–141)
4. Why is acrylic considered more durable than fiberglass? (See "Plastics," page 142)
5. What are the manufacturing differences that affect the quality of a stainless steel kitchen sink or bathroom lavatory? (See "Stainless Steel," pages 144–145)
6. Why is vitreous china considered the most sanitary material for bathroom fixtures? (See "Vitreous China," page 146)

Fixture Design and Planning Considerations



A large array of fixtures is on the market for residential kitchens and bathrooms. In the kitchen, the focus is primarily on the sink center. Bathrooms include at least three fixtures: the lavatory, the bathing fixture, and the toilet. Four or more fixtures can be specified for a residential bathroom if specialized fixtures, such as bidets and urinals, are included, or if more than one lavatory is planned for the individuals sharing the space. Designers need to be familiar with sizes and configurations available in all of these categories as well as how they are installed in residential construction.

Because water conservation is such an important part of kitchen and bathroom design, planners also should be familiar with improvements in toilet-flushing technology that have been introduced over the past years.

In addition to the actual shape of the fixture and its installation concerns, mechanical requirements must be taken into consideration when planning a kitchen and bathroom.

This chapter addresses all of these issues, with material gathered from respected manufacturers and experienced designers. Planning tips from the pros are included where appropriate to provide practical knowledge based on field experiences of practicing designers.

The goal for this chapter is to provide a generic foundation of the choices designers can select from. Supporting information has been included to assist the individual in comparing possible selections.

Learning Objective 1: Identify the different configurations available for kitchen sinks and bathroom lavatories.

Learning Objective 2: Describe the various toilet-flushing systems as they relate to water-saving attributes and high-performance standards.

Learning Objective 3: Explain the planning considerations appropriate for the residential installation of a bidet versus a bidet/seat combination.

Learning Objective 4: Describe how jetted bathtubs aerate water for a restful and invigorating bathing experience.

Learning Objective 5: Understand job site planning considerations for all kitchen and bathroom fixture installations.

KITCHEN SINK AND BATHROOM LAVATORY FIXTURES

The bathroom sink is called a “lavatory,” “basin,” or “bowl.” In this book, they are identified as “lavatories.” The main kitchen sink is called just that: the kitchen sink. Smaller secondary sinks may be specified as a refreshment center sink, a vegetable sink, or decorative apron front fixture with an exposed front panel.

Kitchen Sink Configuration Choices

Kitchen sinks are made out of many materials. Integrated solid surface, cast iron, composite, and stainless steel are the most popular today. Brass, copper, soapstone, and other specialty materials also are used.

Sinks are offered in under-mount, flush, and self-rimming configurations (see Figure 4.1). This chapter addresses sink construction and configuration as it relates to sizes and mounting methods.



FIGURE 4.1 Typical sink configurations: A single stainless steel sink, an apron stainless steel sink, an under-mounted stainless steel sink with sliding wood block, a custom solid surface sink with drop-in cover.

Courtesy of Jenn-Air and Ellen Cheever, CMKBD, ASID, CAPS

Sinks come in a variety of sizes.

Single sinks. 24 to 30 inches wide. In small kitchens (less than 150 square feet in size), it is not uncommon to have one single-bowl sink specified. This sink is generally 25 or 24 inches by 22 inches in size. This sink can fit in a 27-inch-wide cabinet.

Double sinks. Varying in depth, double or triple-bowl sinks are more often specified in kitchens larger than 150 square feet.

Apron panel sinks. Specially designed sinks featuring an exposed or decorative front apron are available in double and single configurations.

Special-purpose sinks. Second or even third sinks in kitchens come in a variety of configurations. Small square, round, and rectangular configurations are popular if the second sink will be used mainly in a beverage center. Larger sink configurations, with or without attached drainboards, are available if the second sink will handle more of the cleanup responsibility or serve a second cook. Sinks of unusual shapes and unique materials are also available.

Sink/counter-section combinations. A sink *center* rather than a plain sink is also available in corner configurations and in 36- to 60-inch sink/counter combinations. Built-in front towel bars, adjacent drainboards, or customized-raised compartmentalized storage areas behind the faucet are available.

Kitchen Sink Accessories

Specifying accessory items can increase functionality of both primary and secondary sinks in a residential kitchen dramatically. These accessory systems allow the sink to be a large, open water appliance or a much smaller water/drain source with integrated multitasking work surfaces or storage containers placed within the overall dimensions of the sink. Some of the more popular categories of sink accessories are:

- **Work surfaces integrated into the sink.** Special chopping surfaces that either cover the sink or *ride* along a channel are available, as seen in Figure 4.2. Stainless steel pipes encapsulated in a rubber mat can be placed over the sink so it serves as a landing or countertop area, yet water can reach the drain when necessary. Nonwood chopping surfaces and preparation container systems are available.



FIGURE 4.2 Kitchen sink accessories: (a) Are used during meal preparation and (b) removed for after meal cleanup. Design by Ellen Cheever, CMKBD, ASID, CAPS



FIGURE 4.2 (Continued)

- **Interior sink rack systems.** These rack systems sit on the bottom of the sink or rest along a ledge designed into the sink side. This allows one compartment to be used for refuse and the other for gathering soiled items destined for the dishwasher.
- **Baskets/colanders.** Fresh food containers can be supported by a runner along the edge of the sink or can be an integral part of the sink.
- **Accessories that can be positioned along the sink interior with a magnetic connection.** In one system, the stainless steel sink has a stripe of magnetic material on the outside, allowing baskets and other accessories to be attached to the inside of the sink.

These accessories may match the sink color, contrast with the sink material, or be a combination of the sink's color and stainless steel. In many cases, they are wire-rimmed containers or stainless steel baskets. They dramatically enhance the multifunctioning ability of a large or small sink to serve as a water appliance when needed and a counter surface when not.

Planning Tips from Kitchen Pros

Bowl arrangement. Unless your client is going to wash and rinse dishes in a double sink configuration, demonstrate how a sink with one large compartment and one small compartment functions. This configuration gives you the largest sink for everyday use and a smaller—yet usable—compartment for other uses.

Corner sinks. When placing a sink in a corner, do not push it back more than 2 or 3 inches away from the front edge of the countertop. That is the normal installation location, and it should be maintained (even in a custom design) so the client has comfortable access to the water source.

Damage. Make sure your client realizes that cast iron, self-rimming sinks are susceptible to damaged edges or to warping. This is particularly a problem with larger sinks. Make sure you inspect the sink before it goes to the job site. Look for chips along the lead edge. The client must accept the possibility of a wide caulking joint connecting the sink to the countertop for large sink configurations. If this will not be acceptable, specify another type of sink. With these self-rimming sinks, also make sure you specify caulking that will match either the countertop or the sink so the joint compound does not become a focal point in the sink area.

Depth. The deeper the sink, the straighter its sides. The tighter the angles where the sink side and bottom meet and the flatter the sink bottom, the bigger the interior space is.

Food waste disposer compartment. Some sink configurations are a single size (24 by 21 inches) but have a small, round compartment for the food waste disposer in one back corner. Because the compartment for the food waste disposer is almost too small to use, this is not the most desirable sink configuration.

Holes. Make sure you know how many holes are on the back ledge of the sink and how many holes you need for the faucet and water attachments. If a hot water dispenser, a faucet, a dishwasher air gap, other dispensers, and/or water treatment spouts are planned, you may run out of predrilled holes. Typically, cast iron sinks have four holes. A fifth hole can be drilled, but it is expensive and the sink may be damaged. Adding extra holes is much easier in a stainless steel sink. In solid surface sinks, the holes are drilled in the countertop deck so the number and placement are flexible.

Overall size. When specifying a solid surface integral sink, verify what the actual overall dimensions of the sink are. The sink literature may list the interior dimensions of the sink, not the overall dimensions. The overall dimensions will determine your spacing in a standard side-by-side double configuration. You may find it necessary to increase the cabinet size if you are planning to create a butterfly corner arrangement with such sinks.

Recycle center. Some sinks have an opening within the sink that allows access to a chute for a compost container or a waste receptacle below.

Round shapes. If you are going to specify two round sinks as the primary sink arrangement, make sure your client understands that the interior space of these sinks is less than a comparable square model. Also, recognize that these sinks require deck-mounted faucet locations; therefore, you must specify the faucet location on your plan.

Small sinks. Avoid small, 12-by-12-inch sinks. They have a drain that does not accept a food waste disposer and are so small there will be a water-splash problem when the cook uses the sink for food preparation.

Strainer. If you are not ordering a food waste disposer to be mounted on the sink, make sure you order a good-quality strainer.

Under-mounted sinks. If you use separate under-mounted sinks in place of a sink manufactured in a double configuration, warn your client that if water is running and the faucet is swung from one sink to the other, water will splash on the countertop. Consider routing down the countertop section that separates the two sinks or recessing the entire configuration into the counter surfaces $\frac{1}{4}$ inch or so in order to eliminate the potential for water to run across the countertop and down to the floor as the spout is moved from sink to sink while water is running.

Bathroom Lavatory Configuration Choices

Know the different types of lavatories available to you.

Console table. A separate or integral fixture that is installed above or below a countertop material that is supported by decorative legs, creating a console piece of furniture, as shown in Figure 4.3. Plumbing lines are partially concealed by the front edge of the console furniture piece.

Countertop. A separate fixture installed above (see Figure 4.4) or below (see Figure 4.5) the level of the countertop material. Plumbing lines are concealed in the cabinetry.

Integral. A fixture that is fabricated from the same piece of material as the countertop material, as seen in Figure 4.6. Plumbing is concealed in the cabinetry.

Pedestal. A freestanding fixture (see Figure 4.7). The water supply lines are visible. The trap is partially concealed by the base.

Vessel/above counter. A decorative lavatory that sits on top or is partially recessed into a vanity countertop.

Wall hung. A fixture that hangs from the wall. The plumbing lines and trap are visible, unless a shroud is used to cover them.



FIGURE 4.3 Console table vanity in a large bathroom
 Courtesy of Kohler Company

Planning Tips from Bathroom Pros

Integral Lavatory

Integral bowls are the easiest to clean because of their seamless configuration. Be forewarned—they are also typically the shallowest types of bowls available. Therefore, in a shallow integral bowl, a high arched spout might cause a splash-back problem that the client finds unacceptable. If you are dealing with an integral bowl that is shallow, stick with standard-type faucets to minimize the splash-back problem. Additionally, it is a good idea for clients to understand that splashing may occur until they grow accustomed to using the faucet at the lavatory.

Pedestal Lavatory

A variety of sizes is available. The smallest pedestal lavatory is little more than a bowl on a base. Larger pedestal lavatories offer a generous bowl and counter space on each side of the lavatory. Plumbing specialists suggest you think through the following items when you specify a pedestal lavatory.

Open pedestal base. The pedestal base may be open all the way down the back, may be solid up to 16 inches off a finished floor, or may have a horizontal support bar connecting both sides of the pedestal base somewhere along the back. These last two fixture designs may interfere with the drain location. Therefore, read the manufacturer's specifications to verify what the back of the pedestal base looks like and where the drain line should be roughed in.

Finishing the pipes. Because the pedestal base is at least partially open, do not install a mirror behind the unit. To maintain continuity, remember to consider the decorative finish on the shut-off valves, P trap, box flange, and supply lines as you select the other fittings in the bathroom.



FIGURE 4.4 A lavatory installed above the vanity countertop.

Design by Scott Gjesdahl, codesigner Sandra Gjesdahl. Photo by Roger Turk-Northlight Photography

Blocking in the wall. If the pedestal lavatory does not completely support its own weight, the installation may require reinforcement behind the finished wall surface.

Vertically align the pedestal. Because the plumbing lines are exposed behind the vertical pedestal base, it is critical that the drain and supply lines are dimensionally balanced behind the pedestal. This is far less critical inside a vanity cabinet, where the supply lines can be anywhere within the open cabinet space. For a pedestal lavatory, the rough-in dimensions must be perfectly centered on the pedestal—make sure your plans are accurate.



FIGURE 4.5 A lavatory installed under the vanity countertop.

Design by Elizabeth Schulz, AKBD, codesigner John David Burkholder. Photo by Mollie Swartz



FIGURE 4.6 An integral lavatory: The lavatory sink is made of the same material used for the countertop. *Courtesy of Kohler Co.*

Selecting the right faucet. Your choices of faucet handle style and escutcheon plate diameter may be limited if the pedestal lavatory has a small back deck or if there is an integral splash along the back of the fixture. If you are specifying a fitting that has not been designed to fit on the pedestal lavatory by the fixture manufacturer, verify that these two items are compatible by reviewing the dimensional information from both companies.

Specifying the height. The design of some pedestal lavatory bases limits the shut-off valves to about 16 inches off the finished floor. This height dimension is as important as the vertical arrangement just mentioned.

Countertop-Mounted Self-Rimming Lavatory

If the lavatory is designed to sit on top of the countertop, it is called self-rimming. If it does not have a finished edge, it will require a rim of stainless steel, or it can be under-mounted. The lavatory features a rim around the edge of the bowl that overlaps a cutout in the countertop. A bead of sealant is placed between the bowl rim and the countertop to prevent water seepage. The weight of the fixture, sealant, supply lines, and trap hold the lavatory in place.

Warpage. Self-rimming lavatories are susceptible to warpage. Large lavatories, and particularly oval designs, may not fit flush on the countertop. Because they do not rest perfectly on the countertop surface, they will require a larger caulking line. The client must understand this and must be willing to accept the fixture with this installation.

Templates. For some handmade china self-rimming bowls, no template will be available. In a bathroom with more than one lavatory, do not allow the installer to use one bowl to template all the lavatories—there may be slight differences. Therefore, each lavatory should be used for its own template in this unusual decorative situation. As a general rule, make sure the self-rimming lavatory is on the job when the countertop is cut. That way there will be no mistakes.

Ledge drilling. The drilling location for a self-rimming lavatory must be verified before the cabinetry is ordered. Most standard self-rimming lavatories have one hole: a 4-inch center set drilling or 8- to 12-inch widespread drilling as part of their back ledge. Therefore, no special dimensioning is required because the overall depth of the lavatory will accommodate the bowl, overflow, and plumbing lines to the faucet.



FIGURE 4.7 Pedestal lavatory: Pedestal lavatories are normally part of a suite by the plumbing fixture manufacturer. The details of the group of fixtures are repeated in the toilet and the bathtub. *Courtesy of Kohler Co.*

However, pay particular attention to the number and diameter of the holes drilled in the lavatory. As you will learn when we talk about lavatory faucets, a mini-widespread faucet does not use an escutcheon plate and has rigid piping, so there is no flexibility in the distance separating the valves from the spout. Therefore, if there is any discrepancy between the drilling holes on the lavatory and the faucet drilling, it will not work.

Another compatibility problem may occur when you attempt to specify a single-hole faucet with an escutcheon plate on a lavatory faucet that has been drilled with three holes. Sounds simple enough—you are going to use the escutcheon plate to cover the two unused holes. However, the diameter of the predrilled holes in the lavatory may not be suitable for a single-hole faucet. On many lavatories drilled for a standard 4-inch center set, the center hole will

only be $1\frac{1}{8}$ inches in diameter. For a single-hole faucet, you will need a hole that is $1\frac{1}{4}$ inches in diameter. It is difficult, and expensive, to drill a cast iron lavatory, and the potential for damage is great.

Vessel/Above-Counter Bowls

Special planning concerns are involved in installing a sink that sits on the bathroom counter or is partially recessed in the counter. These concerns revolve around the height of the user, the faucet location, and the relationship of the vessel bowl to the countertop.

Installation of vessel/above-counter sinks, as seen in Figure 4.8, requires special planning. Check the overall depth of the vessel sink; it may require a deeper vanity than you are accustomed to specifying.



FIGURE 4.8 Vessel/above counter bowls: A stone vessel lavatory sits atop a connecting cabinet with wall-mounted faucets.

Design by Joseph Giorgi, Jr., CKD, Ellen Cheever, CMKBD, ASID, CAPS, and Pietro A. Giorgi, Sr., CMKBD

Select the drain you will use; it may be much more decorative than a typical drain and be ordered from a specialty house.

Specify the faucet to match the vessel height. Elongated faucets are specifically designed for countertop installations with a vessel sink. Alternatively, wall-mounted bathroom lavatory faucets are available. The trajectory of the water flow from the faucet must be matched with the shape and configuration of the vessel bowl to make sure there is not excessive splashing on the user.

User's height. A vessel bowl placed atop a typical 32- to 36-inch-high vanity cabinet may be too high for a more petite user and definitely is inappropriate in a children's bathroom. Consider the actual physical height of the individual who will be using the vessel sink. If need be, partially recessing the vessel fixture may give you the look desired without added height.

Faucet location. Plumbers are not accustomed to vessel bowls—the craftspeople on the project need to be aware that the faucet positioning will be very different for this type of special lavatory. A wall-mounted faucet needs to be positioned exactly by the designer for the craftsman on the job. If a wall-mounted faucet is not being used, special decorative deck mounted faucets that are installed adjacent to the vessel sink (not behind because you cannot reach the overflow or the controls) need to be specified.

Relationship of the vessel bowl to the actual countertop. The designer needs to think through the material of the countertop, the material of the vessel bowl, and the waterproof caulking compound that will be used to join the two together. In many installations today, we see beautiful glass vessel bowls in glass countertops—once again, the finish and fit of all plumbing (which is now dramatically exposed) must be thought through before the project is finalized—from a planning and budgeting standpoint.

Mounting Methods for Kitchen Sinks and Bathroom Lavatories

There are several ways to mount a sink or lavatory:

- **Flush-mounted.** The sink is recessed into the countertop substrate material so it is even with the counter material. This is particularly effective in a ceramic tile top. Special sinks are designed that have square ledges so the sink sits on the countertop and can flush-out with the ceramic tile on the deck.
- **Integral.** As the name implies, the sink and countertop are all made out of one piece. This can be done with stainless steel or solid surface materials. The opportunity to create a uniquely arranged sink configuration, the ability to specify an attached drainboard, and the ease of maintenance are all advantages to this type of installation.
- **Rimmed.** The sink sits slightly above the countertop with the joint between the sink and the countertop concealed by a metal rim.
- **Self-rimming.** The sink sits on top of the countertop. A hole is cut in the surface and the fixture is dropped in by the installers. A bead of caulking is applied between the sink and countertop, forming a seal.
- **Under-mounted.** The sink is installed underneath the countertop. (See Figures 4.9 and 4.10)

If you are under-mounting a cast iron sink, always order it with a glazed rim. Make sure your client understands there will be a joint where the sink and the countertop meet for sinks that are of dissimilar materials.

A traditional under-mounted stainless steel or composite sink has a square countertop lip extending down to the curved top edge of the sink. A second type of installation can be specified if the sink has a square edge so the joint contour is minimized. A third type of installation maximizes the set-back dimension between the countertop edge and the sink edge, providing a ledge for the accessories discussed earlier to be mounted to or to slide back-and-forth. With solid surfacing, a seamed under-mount can create a flush joint between the bowl with the square top edge and the similar countertop material.



FIGURE 4.9 Mounting methods: An apron front stainless steel sink mounted below a quartz surface.

Design by Pietro A. Giorgi, Sr., CMKBD, and Ellen Cheever, CMKBD, ASID, CAPS

TOILET FIXTURES

A toilet, or *water closet*, is designed as the fixture used by both males and females. The fixture holds human waste and then flushes it out through the waste lines in the home to the city sewer system or to a septic system.

Selecting the Right Name

The term “water closet” comes from a European home design that featured the toilet and a small lavatory in one room separated from a larger room housing the bathtub—an early version of compartmentalizing the bathroom. This design allows one family member to bathe



FIGURE 4.10 Mounting methods: A decorative under-mounted lavatory sink in a marble top.

Courtesy of Kohler Co.

while another uses the toilet. Therefore, the term “water closet” really refers to the room, not the fixture.

In North America, the term “toilet” is used most often. You and your company will decide if you want to use the trade designation water closet, or if you prefer to call the fixture a toilet when talking to clients so they are not confused by unfamiliar terms.

Water Conservation Considerations

Flushing toilets waste potable (usable) water more than any other fixture. Therefore, toilets that use as little water as possible to completely flush liquid or solid waste in one operation are highly valued.

Pre-1950 toilets required 7 gallons (26 liters) of water to complete the flushing action. Today, toilets are available that require as little as 1 gallon (3.75 liters) of water to complete the flushing action. A public/private partnership program, called WaterSense, between the US Environmental Protection Agency (EPA) and manufacturers certify water-efficient products. WaterSense products have been independently tested and certified. Products that meet the WaterSense standards can bear the WaterSense logo (see Figure 4.11) in all packaging, marketing, and promotion.

Generally, products that meet the WaterSense standards are 20 percent more efficient than comparable products on the market. In addition, the products must perform their intended function without sacrificing performance, especially to conserve water.

The current standard for a toilet is 1.6 gallons per flush (GPF). The WaterSense toilet specification is 1.28 GPF. Some toilets on the market offer even more efficient water use, such as 1.0 GPF. Manufacturers have achieved the efficient use of water for toilet flushing with different technologies. This includes improving the existing flushing system or using air pressure to power the flush. Dual flush systems have been introduced: More water is used when flushing solid waste than liquid waste. Some toilets use a pump to assist the flushing, which requires an electrical connection.

WaterSense toilets must meet the minimum maximum performance (MaP) testing threshold for flushing of solid waste: 350 grams of solid waste (including toilet paper) in a single flush. This is an important standard: Older toilets reduced the water necessary to complete the flush



FIGURE 4.11 WaterSense logo
US Environmental Protection Agency

but often required double flushing to remove solid waste. The MaP is a voluntary testing program recognized in both the United States and Canada.

Graywater

Conserving water is the first step. Another approach is to reuse or recycle water. Reusing water is a sustainable practice that has all the same benefits of using less water. The term “recycled water” is used to describe the practice of treating wastewater, usually in a central location, and then using the water for a variety of purposes, including landscaping or toilet flushing. The interest in graywater use is growing, particularly in the southwestern and western United States, where water supplies are limited.

The 2012 International Residential Code (IRC) details the design of graywater recycling systems in a section on sanitary drainage. Some local codes now require new residential construction to include connections for graywater plumbing. According to the 2012 IRC, discharge water may be collected from bathtubs, showers, lavatories, clothes washers, and laundry trays for a graywater system. The water collected is then used for flushing toilets and urinals or landscape irrigation.

Including a graywater system in a bathroom design can be challenging: The system needs to be sized correctly, and there are requirements for additional plumbing pipes. A collection reservoir or storage tank is needed. Designers must be familiar with all applicable codes and permits and seek additional expert advice.

Toilet Construction

Nearly all toilets are made of vitreous china—a hard, high-fired, nonporous ceramic material similar to porcelain. A high-gloss glaze fused to the china's surface further adds to its excellent sanitary properties. Figure 4.12 illustrates a typical toilet configuration.

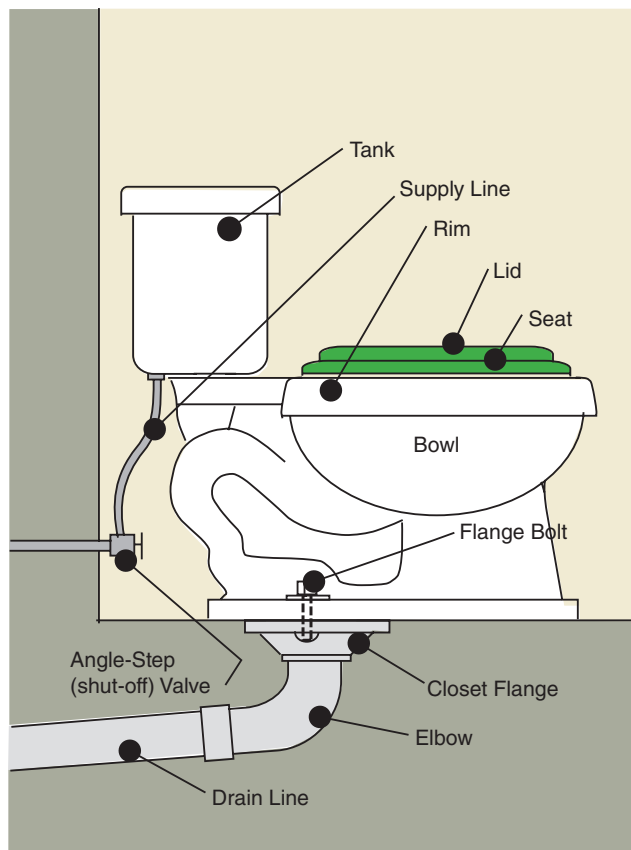

FIGURE 4.12 Fixture design: Typical toilet configuration

Toilet Styles and Types

Toilets without Exterior Storage Tanks

The toilet bowl can be suspended from a hanger system that is installed between 2-by-4-foot or 2-by-6-foot studs. The in-wall tank is constructed of sturdy-proven plastic material. The dual flush activator is installed on the wall behind the toilet bowl. For this type of toilet, two items are purchased: the hanger system, which is installed in the wall; and a tankless toilet with seat from a respected North American or international plumbing fixture manufacturer.

Toilets with Exposed Tanks

More widely used in residential installations are toilets with tanks. These may be one-piece or two-piece toilets. Most two-piece models are close-coupled with the tank being supported by and bolted to the bowl.

Toilets can be floor mounted, as in Figure 4.13, or wall hung, as in Figure 4.14. Toilets are available in two heights. The taller toilet is called a comfort height because it makes sitting and standing easier.

Toilet Seats

There is a wide choice of elongated or round bowls, each accepting standard-size seats. Some luxury toilets are supplied with seats specifically designed for the toilet. Seats are available today with a *soft close* feature, making them close quietly. Seat shapes are available in both round and elongated configurations.

Toilet Rough-in Dimensions

A wide variety of floor-standing toilets with floor outlets has a 12-inch rough-in dimension (the distance from the center of the outlet to the finished surface of the wall). A limited selection of models has either a 10- or a 14-inch rough-in, which are sometimes required for retrofit projects.

Flushing Methods and Devices

Toilets are flushed either from a tank or directly from the water supply.



FIGURE 4.13 A floor-mounted toilet
Courtesy of American Standard



FIGURE 4.14 A wall-hung toilet: Wall-hung toilets are used most often in contemporary environments but can also be used in traditional design settings.

Design by Pietro A. Giorgi, Sr., CMKBD, Joseph Giorgi, Jr., CKD, and Ellen Cheever, CMKBD, ASID, CAPS

Older toilets used 3.5 to 7.0 GPF (13.2–26.5 liters) of water to complete the flushing action. This system uses the force of gravity alone. A backflow-protected fill valve (ball cock) and a flush valve are incorporated in the tank to provide a gravity flush.

Water conservation initiatives and extensive reengineering efforts by leading plumbing fixture manufacturers have led to a wide variety of high-performance toilets that use much less water. One major improvement is the dual-flush actuator. A special handle mounted on the side of the tank, or a push control on the top of the tank or mounted on the wall, provides a light flush for liquid waste and a full flush for solid waste. This toilet uses the force of gravity and a precision-engineered tank, bowl, and trapway to create a strong siphon during flushing.

GPF Toilets

Gravity flush. Toilets with 1.0 to 1.6 GPF (3.8–6.1 liters) tanks are available either with a gravity flush (for which the flushing devices are similar to those in a 3.5-GPF [13.2-liter] toilet) or with a pressure-assisted flush.

Pressure-assisted flush. This toilet type has a pressure vessel in the tank that contains both water and air. The air is compressed by supply system pressure as the refill charges the tank. When the toilet is flushed, the air pushes the water out of the tank at high velocity. The toilet bowl (which has been specially designed to accept this water stream) is quickly emptied. This type of flushing system is noisy.

Flushing Action of Bowls

There are several basic approaches to designing the flushing action, each with its own unique performance characteristics. In addition to performance considerations, factors to consider in design include:

- More efficient toilets have a smaller “water spot.” That means there is less water in the toilet bowl before the flush is activated.
- New trapway systems have been designed to streamline the “tunnel” leading from the bowl to the waste pipe.
- Extent of glazing in trapway. A completely glazed trapway provides a smooth, minimally resistant passage for waste materials.
- The way the water enters the toilet bowl at the beginning of the flushing action affects the efficiency of the flushing system.

Siphon vortex. This flushing action is based on diagonal rim outlets that cause a swirling or whirlpool action. The resulting rapid filling of the trap triggers the siphoning of the bowl contents. Vortex designs are known for their large water surface area and extremely quiet operation. This swirling water action also leads to a self-cleaning toilet bowl as the water rinses the surface.

Siphon wash. This is one of two designs that do not incorporate a jet to develop a siphoning action. It relies entirely on the incoming rush of water from the rim. The resulting rapid filling of the trap triggers the siphoning of the bowl contents. Its small water surface makes it more vulnerable to soiling and staining.

Siphon jet. Similar in basic concept to the siphon wash design, this style is more advanced in efficiency. The jet, in this case, delivers flow with such a volume as to begin the siphoning action instantly, without any rise in the level of water in the bowl before the contents are drawn through the outlet. In addition to quiet operation, siphon jet designs also provide a larger water surface area.

Blowout (compression). This is the one design in the group that does not incorporate a siphoning action. Instead, it relies entirely on the driving force of a jet action. Because of the water capacity required to accomplish this, blowout designs are used in tankless installations only, in combination with a flush valve. Such designs are known for their generous trapway size and large water surface area.

Toilet Planning Tips from Bathroom Pros

Specify the actuator finish. Always check the tank lever or push-button actuator finish against other fitting finishes if you wish all to blend. The tank lever can be a button at the top of the tank, a valve on the side of the tank, or a valve on the front of the tank. Decorative actuators are generally the most appropriate for toilets with the actuator on the front of the tank.

Verify the floor outlet rough-in. If you are working in a house that is 50 years old or older, double-check the drain outlet dimension by measuring from the finished wall surface to the center of the bolts on each side of the existing toilet. The 10- and 14-inch rough-in dimension toilets were used in many cases in the old days. You may need to order a fixture in one of

these older rough-ins. This approach will severely limit the models you have to choose from. Alternatively, you may select to use an offset flange (ring) to modify the old outlet center dimension to today's more standard 12 inch. The ring lets you offset the fixture outlet by up to 2 inches.

Measure from finished wall. Remember, the rough-in dimension is always from the finished wall surface to the center of the drain. If you are installing a tile wainscoting around the room and planning on a "mud" tile installation, you may need to rough-in the toilet at 13½ inches from the drywall surface so you truly have a 12-inch finished rough-in from the finished tile surface to the center of the floor outlet.

Realize the PSI will vary. All toilets recommend a particular pounds per square inch (psi) of pressure available at the fixture sufficient to clean the bowl with one flush. However, remember that the time of year, household activities, and neighborhood activities will all affect the available water pressure. This is discussed in Kitchen & Bath Residential Construction and Systems volume of the NKBA Professional Resource Library.

Think about cleanability. Some toilets are easier to clean than others are. If easy cleaning is a major concern of your client, look for a one-piece toilet and, in particular, one with straight sides that conceal the caps covering the bolts holding the toilet above the floor outlet.

Remember that fixture sizes vary. One European toilet is only 14 $\frac{7}{8}$ inches wide. Typical North American products are from 20 to 24 inches wide. The standard seat height is 14 to 15 inches high. Fixtures with 17- to 19-inch-high seats are also available and are the most comfortable to use by adults and individuals with physical limitations affecting their mobility.

Understand that different supply lines and rough-ins are specified for different toilets. A low-profile toilet requires $\frac{1}{2}$ -inch rigid water supply lines—not the $\frac{3}{8}$ -inch lines typically called for with a two-piece toilet.

Additionally, the height of the supply lines for a one-piece toilet is generally lower than for a two-piece toilet. Check each manufacturer's specification sheet before specifying the supply line pipe diameter/type and/or pipe. Make sure you identify this dimension before you specify the finish baseboard material. There is nothing more unsightly than a 4 $\frac{1}{2}$ -inch ceramic tile baseboard with $\frac{1}{4}$ -inch round trim that is interrupted by a supply line half in/half out of the baseboard dimension.

Make sure the client is prepared for the noise associated with 1.0- to 1.6-GPF (3.8–6.1 Liter) pressure-assisted toilets. Pressure-assisted 1.0- to 1.6-GPF (3.8–6.1 liter) systems cost more than gravity-flow units and they are noisier. Although the noise is only heard for an instant, as the pressure moves the water through the system, this may be unacceptable in a powder room adjacent to an entertaining area or in the middle of the night in the master suite. To minimize the transmission of this noise, try to avoid placing a pressure-tank toilet on a common wall separating the fixture from spaces occupied by guests or other sleeping family members.

BIDET FIXTURES

The *Bath Planning* volume of the NKBA Professional Resource Library explains in detail how a bidet is used. Please read that information before proceeding if you are not familiar with bidet fixtures. This book describes how the fixture is designed.

Three different types of bidets are available from fixture manufacturers.

Separate Fixture, Rim-Filled with Vertical Spray

This type of bidet provides an ascending jet spray as well as a bowl-filling mechanism through holes along the rim. A vertical spray delivers water through the outlet in the center of the bowl, allowing the user to direct the spray to the desired area simply by sliding the body forward and backward on the bidet.

This type of bidet requires five components:

1. Individual hot and cold valves
2. Diverter valve
3. Pop-up drain control
4. Spray fitting
5. Connections to the waterways

Such bidet fittings come complete from the faucet manufacturer. Specify deck-mount or wall-mount fittings according to the type of bidet chosen. To ensure compatibility, some faucet manufacturers will require you to specify the bidet model chosen.

Because the bowl can be filled to a height above the vertical spray, the possibility of contaminated water entering the potable water system exists. This phenomenon is called backflow. This situation can occur if the city's water supply temporarily has negative pressure (if it sucks instead of pushes), causing a vacuum to be created that would pull contaminated water standing above an inlet into the potable (fresh) water supply.

To prevent such water contamination due to a backflow, a vacuum breaker must be installed behind the bidet. This protective device breaks the backflow, or suction action, by allowing air into the piping system. Check that the vacuum breaker is supplied with the selected bidet fitting. This will ensure adaptability between the systems. Alternatively, there are firms that provide *fit-all* vacuum breaker systems that adapt to most faucet lines and may be more attractive.

Separate Fixture, Over-Rim with Horizontal Spray

This bidet has no ascending jet spray in the center of the fixture. It is filled by means of a deck-mounted faucet—like a lavatory faucet—that discharges water over the rim in a horizontal stream. This type of fixture is generally less expensive to purchase and install than the rim-filled bidet with a vertical spray because both the bidet and the faucet are simpler to produce and a vacuum breaker is not required.

Alternatives to a Bidet Fixture

Manufacturers today offer a combination toilet/bidet fixture, which has been completely designed and engineered to accommodate the dual function of a toilet and a bidet. Additionally, major manufacturers offer toilet seats that have bidet functions built in.

Bidet/Toilet Fixture

This combination fixture is larger in width and depth than a typical toilet so that it is an extremely comfortable bidet fixture. It typically is controlled with a remote control that provides choices among type of spray (front/rear), intensity of spray, and directional nature of spray. The seat also has a warming function and may have an iPod docking station.

Bidet Seat

The bidet seat is a toilet seat that is also a bidet. For comfort, these seats have a control panel on the side of the toilet, which allows the user to activate a streamlined wand that extends from the back of the seat into the bowl, providing a smooth, warm flow of aerated water for complete cleansing. The nozzle automatically self-cleans before and after use. In addition to water, some bidet seats have air dryers and are heated. An air purifier is also available.

These fixtures require a 120-volt electrical line: a mechanical element not typically associated with toilet installation.

Bidet Planning Tips from Bathroom Pros

Drain location. The bidet drain is more like that of a lavatory than that of a toilet. Therefore, there is no fixed rough-in recommendation for the drain outlet. Refer to the selected manufacturer's rough-in book for specifications appropriate for a certain fixture.

Coordinate with the toilet. Because bidets are installed adjacent to or across from toilets, fixture manufacturers design suites of products so the rim height is coordinated between the toilet and bidet, as are the shapes and configurations of the fixtures.

Selection of faucets. The faucets selected for the bidet must be compatible with the fixture. Not all china products accept valves from other manufacturers. Sometimes, if you order fixtures and fittings from different manufacturers, the hole configuration on the fixture or the shank on the valve and the bidet fitting may not coordinate with one another. (This is a particular problem with an American china piece and a European faucet.)

RESIDENTIAL URINAL FIXTURES

Urinals are available in a wall-hung variety, a stall type that extends from the floor up, and a trough that is mounted horizontally on the wall. Wall-hung units are most widely used. They require the least amount of space, offer the most placement flexibility, and typically are the most attractive. They are made of vitreous china.

Although it would make sense to install urinals in residential bathrooms, they are rarely seen because most are designed to rely on the building's water pressure and piping system to deliver the necessary water to complete the flushing action and therefore do not have a storage tank. They commonly use the flushometer valve. (Recently, waterless urinals have been installed in large commercial and industrial facilities in an effort to conserve water.)

Designers also have designed them into home plans. They are ideal in a master suite, where the man has a small room with his toilet and urinal, and the woman has a toilet and a bidet. Other ideal locations are a boy's bathroom and the entry bathroom off the deck, pool, or patio area.

BATHTUB FIXTURES

A wide variety of bathtubs is available today. Although there are many different shapes and sizes (see Figure 4.15), there are four broad categories of bathtubs as defined by the installation method.

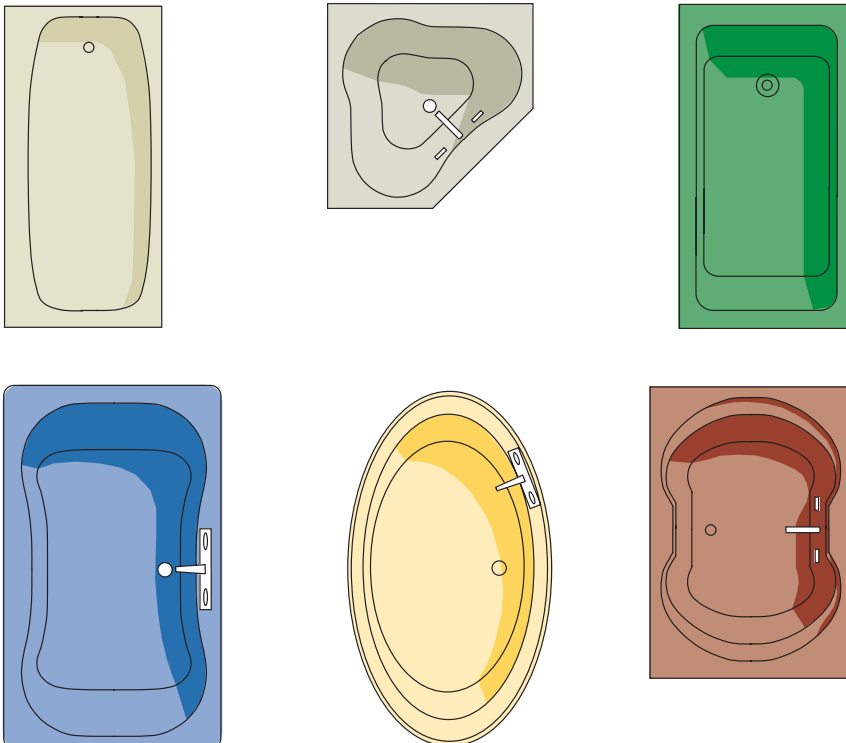

FIGURE 4.15 Typical bathtub configurations

Types of Bathtub Fixtures

Corner Bathtubs

Corner units are available in two styles. One type is available in a configuration similar to the standard recessed bathtub but in addition to the front being finished, one end also has a finished panel. Another type of fixture is designed to fill a corner and features three angled or curved finished sides. Several manufacturers have introduced sculpted bathtub shapes (see Figure 4.16) that offer a wider variety of configurations for corner installations.

This second type of corner tub generally requires from 48 to 60 inches along the back two walls and extends from 60 to 72 inches out from the back corner into the center of the room. It is a space-efficient way to plan a whirlpool bath if the available back wall space is limited.

Freestanding Bathtubs

Unique, freestanding bathtubs are also available from several manufacturers. These fixtures can be placed along a wall, at right angles with a wall, or in the center of a room. They are available in *claw-foot* reimagined bathtubs reminiscent of Victorian-style bathrooms. They are also available in contemporary shapes. In addition to cast iron, acrylic/fiberglass/other plastic materials, they are available in copper and wood.

Freestanding bathtubs have three major design considerations:

1. The height of some of these freestanding fixtures makes them unsafe for petite users. Because the fixture is a freestanding element, there is no platform ledge for users to sit down on and then swing their legs into the bathtub as they enter.
2. These fixtures have no available flat space for soap, washcloths, or other items used when bathing.
3. Freestanding bathtubs as seen in Figure 4.17 require a specially designed floor-mounted bathtub filler system or must be placed close enough to a wall to use a more typical bathtub filler fitting set.

As you will read in the section about safety and showering, these freestanding bathtubs generally should not be planned as showering facilities. This is also discussed in the *Bath Planning* volume of the NKBA Professional Resource Library.

Recessed (Alcove) Bathtubs

This type of bathtub comes without finished ends and with one finished side, typically called the *apron*. The bathtub is designed to slip between two end walls and against a back wall,



FIGURE 4.16 A corner bathtub can save valuable floor space.
Courtesy of Kohler Co.



FIGURE 4.17 A freestanding bathtub can be contemporary or traditional in styling.
Courtesy of Kohler Co.



as seen in Figures 4.18 and 4.19. You must specify a left or right drain so the drain is in the proper relationship to the finished front. When you are standing in front of the bathtub—about to enter—and the drain is on the left, it is a left-hand bathtub. Many bathtubs feature well-engineered, integral backrests and grab bars.

Typical sizes are 30 to 34 inches wide, 14 to 20 inches deep, and 60 to 72 inches long. These tubs generally have an integral tile flange on the two side walls and the back so when the wet wall material is installed, water will not be able to wick up behind the surround material and damage drywall or wood studs. Many manufacturers also offer a tile bead kit that allows you to transform a bathtub without such a flange into a recessed unit.

Platform Bathtubs

A popular type of bathtub is a platform bathtub. (See Figure 4.20.) This bathtub has no finished panels. It is designed to drop into a platform made of another material. Designs are similar regardless of material, but there are some limitations on the cast iron fixture sizes. Because these bathtubs are dropped into a platform, the edge detailing of the bathtub adds to the design statement.

For this type of installation, the designer should be very careful about the relationship of the raised bathtub ledge and any back corners of the platform if the bathtub also will serve as a shower. Water can pool in the corners and cause a cleaning problem.

Alternatively, some designers prefer to extend the platform material over the bathtub to create an under-mounted installation. This latter installation may make it uncomfortable for users to rest their head on the bathtub ledge when lounging. It also will significantly increase the cost to change the bathtub if ever necessary.

If a bathtub is a separate fixture from a stall shower, a decorative, protective material is installed that extends upward from the bathtub or deck 4 to 12 inches along the walls



FIGURE 4.18 An alcove bathtub can be combined with a shower.
Courtesy of Kohler Co.



FIGURE 4.19 An alcove bathtub can also be exclusively reserved for bathing.
Design by J. David Ulrich, CKD. Photo by Peter Rymwid Architectural Photography



FIGURE 4.20 A platform bathtub can be top-mounted or under-mounted. In this example, it is top-mounted. In this design, a movable wall opens the bathing center up to the bedroom zone. The space is a hotel room at the Shade Hotel in Manhattan Beach, CA.

Courtesy of Ellen Cheever, CMKBD, ASID, CAPS

that flank the bathtub. This material typically matches or contrasts with the decking material.

Accessible Bathtubs

Several manufacturers offer bathtubs that are labeled accessible. These bathtubs have either a hinged door or a door that raises and lowers, allowing the bather to enter the bathtub, close a door behind them, and then fill the bathtub with water. They are designed for users who may have some physical, mobility, or dexterity limitations.

Key concerns for this type fixture is the water tightness of the door, the time required to fill the bathtub, and, most important, the time required to drain the bathtub. The concerns around this type of bathtub are how comfortable the unclothed user is during the time it takes to fill or drain the bathtub.

Types of Bathtub Experiences

Consumers today can select from a wide variety of bathing experiences. Simply relaxing in a deep, contoured bathtub in warm water is a great way to start the bathing experience. Kohler Company describes them as:

- **The relaxation experience.** This bathing experience combines the effervescence of an air bath system with a relaxing environment that might be enhanced by chromatherapy. (“Chromatherapy” refers to the tangible effect color has on an individual’s body and feeling of well-being: warm colors are stimulating, cool colors are calming.) Thermo-massage



FIGURE 4.20 (Continued)

air jet tubs use a multitude of air jets randomly placed on the floor of the tub and a circular pattern on the edge of the bathtub, creating a turbulence of water by the injection of air. Since, no water is being circulated through a pump, these systems allow the bather to use products such as essential oils to optimize relaxation. This bathing experience can be further expanded with controlled lighting, surround sound systems, and televisions built into tubs.

- **The spa experience.** The spa experience combines the effervescence of an air bath system, chromotherapy, and flexjets. Flexjets are individually adjustable to target specific areas of the body that are found on most systems. Specifically directed back or neck jets are available on other systems.

- **The massage experience.** The massage experience is one where there is a specific sequence programmed into the jets to simulate a spa massage, allowing the user to loosen tension up along the back and across the shoulders. Similarly, neck jets are available.
- **The spa/massage experience.** For the true bathing lover, all of these features can be combined and controlled by a lighted keypad on the side of the tub or a floating remote control.

Perimeter Air Injection Bathtubs: Bubble Massage

A popular alternative to directional hydromassage jets is a bathing experience referred to as bubble or air massage. This bathing experience relies on a large number of perimeter air injection outlets installed along the bottom and/or the sides of the bathtub. Air is pumped through the system into the water bath. Better systems preheat the air, which provides a much more comfortable bath. The bather then enjoys the relaxing sense of thousands of water bubbles wafting around the body.

The system typically is activated by a digital control on the side or top of the bathtub. There may be two or more memory settings available for personalized massage action. The backrest in the bathtub may be heated for additional comfort.

Typically, the system has a check valve engineered into the water supply system, preventing any backflow of water into the piping. This allows the user to add oils or other enhancements to the bathing water, not possible in a hydromassage system. Most systems have an automatic drying cycle that purges any water droplets left on the outside of the air injectors.

Because this is considered a relaxing bathing experience, the noise level is an important factor to consider. Being able to see such a bathtub filled with water and in operation at a supplier's showroom will help you and your client make the best selection.

These bathtubs often have accessory options to add a chromotherapy light and an aromatherapy receptor.

Jetted Bathtubs: Hydromassage

Most manufacturers provide a totally integrated whirlpool system and bathtub that has been factory tested before shipment. Although the *Bath Planning* volume of the NKBA Professional Resource Library discusses the ergonomic planning considerations for this type of fixture, you should also be familiar with the following individual mechanical elements of a whirlpool system (see Figure 4.21):

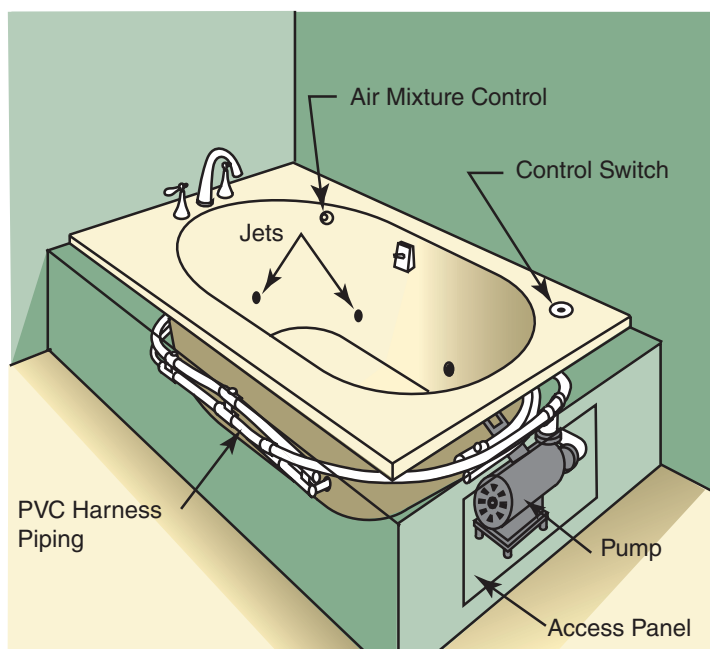

FIGURE 4.21 A typical whirlpool system

Pump. The pump is at the heart of the system. The size of the pump varies in horsepower rating from ½ horsepower (hp) to 1½ hp. However, the horsepower rating is not the only contributing factor to the engineering of the pump and jet system. Therefore, rely on the gallons per minute of water flow pushed through the jets when evaluating the system rather than simply focusing on the pump horsepower rating. Generally, the whirlpool bathtubs are capable of delivering 5 to 7 gallons (18–27 liters) of water per minute, per jet. The system should have UL-approved components. Manufacturers typically have the entire system UL-approved for additional safety assurance and for customer satisfaction.

Activator. Older systems may be activated by a timer switch installed on the wall. If used, locate it out of reach of the bather when he or she is in the tub (most codes call for 39 or 60 inches of distance from the switch to the bathtub) so the chance of an electrical accident is eliminated.

Alternatively, an air switch installed directly on the bathtub may be available. Check the price list—this type of starter may carry an extra charge. When an air switch is depressed, it increases the air pressure, and a bubble of air travels down a length of tube to an electrical switch at the pump. For both safety and convenience, the air switch is superior to an electrical switch.

A third type of switch available on luxury bathtubs is a capacitance level switch. With this type of switch, the sensor operates in a manner similar to a simple capacitor. A high-frequency oscillator is located within the tip of the probe. When the tip of the probe comes in contact with the medium, the frequency of the oscillation reaches a preset point and the protection circuit signals the switch to change state. In a bathtub application, the switch senses the electrical differences that occur when a person lightly touches the control panel and turns the system on.

Wiring. Both 120- and 240-volt pumps are available. Generally, whirlpool bathtubs with a 1-hp motor or less will operate off a 120-volt circuit. Whirlpool bathtubs that have a motor larger than 1 hp will generally require a 240-volt circuit. Regardless of the motor size, if an *in-line heater* is included, a 240-volt circuit may be needed.

Temperature control. An in-line heater can be added to keep the hot water temperature constant. These heaters do not raise the water temperature.

Do not confuse the purpose of an in-line heater with that of a storage tank or a tankless water heater. The purpose of the tank or tankless water heater is to heat water before it enters the bathtub at the start of the bath. The in-line heater simply maintains the water temperature in the bathtub during the hydromassage bath.

An in-line heater is a good enhancement for a whirlpool tub that will be used by family members for an extended period of time. Just as the piping and pump require service access, such a heater should be reachable by repair people in the future. Make sure you have enough electrical power for the 240-volt circuit this heater will require as well.

Minimizing Bacteria Growth in the Piping System

New antimicrobial technologies are used by whirlpool bathtub manufacturers today to minimize the growth of bacteria in whirlpool piping. In some cases, the material is applied to the piping as a coating; in other instances, the inhibitor is actually part of the whirlpool piping system. In all cases, the end goal is to inhibit mold, mildew, and bacteria growth in the plumbing piping.

Purging the Piping Systems

Today, manufacturers have designed their whirlpool systems to ensure a completed drain of all water in the piping; therefore, no standing water remains between uses. Additionally, some systems have an automatic purge cycle set by the user, which blows warm air through the piping system daily at the same time to further inhibit any moisture remaining in the piping.

Accessibility

The pump must be accessible for future servicing, a requirement often overlooked by inexperienced bathroom designers. Check the manufacturer's literature or find out from your supplier where the pump is in relationship to the overall configuration of the bathtub.

For factory-installed systems, the pump fits within the envelope of the bathtub. Some manufacturers offer alternative pump locations of up to 60 inches away from the bathtub. Verify such an option by reviewing the fixture literature. If the manufacturer's specifications do allow a remote location, consider concealing the pump in a vanity cabinet adjacent to the bathtub, in a closet space near the bathtub, or behind a concealed access door along the front apron panel of the bathtub. Wherever it is placed, it must be on the same level as the base of the bathtub to provide a complete drain after each use.

Noise

Be sure to alert your clients to the noise level of all whirlpool systems. The majority of the noise is caused as the large volume of water is pushed through the piping and into the bathtub. Therefore, you cannot design a silent system. However, you can minimize the noise by mounting the pump on a thick rubber block and enclosing it on three sides.

Placement

For proper performance and safety, the pump/motor assembly must be no higher than the highest jet (which is 2 inches below the water level) and no lower than the suction fitting. The piping used to connect the system also must be designed to remain rigid through the fixture's years of use. The piping must be engineered to prevent water from remaining in the lines after use, which can lead to bacterial growth in the standing water. At the job site, the installation crew must be instructed not to pick the bathtub up by the piping.

This pump/jet placement and piping design is required so a 100 percent drain-out of used bathwater will occur every time the bathtub is emptied. If this placement criterion is overlooked, or if the pipe flexes during the bathtub's years of use, the first water to enter the fixture would be contaminated water from the last bath.

Jets

There are two different approaches to whirlpool jet design:

- 1. Fewer jets with larger outlets that are serviced by bigger water lines.** The jets operate on a high-volume, low-pressure system that provides a comfortable bathing experience for the user as softly pulsating water rolls around the body. They are generally noisier than the next option.
- 2. More jets with smaller outlets serviced by small water lines.** These jets operate on a low-volume, high-pressure system to bring the water to the numerous jets, which can be individually adjusted for the user's comfort.

Mixing Air with Water

Better systems inject the air into the water, thereby providing a complete mixture of air and water for a more effective massage. This mixture of air and water is called a *Venturi effect*. To maximize the flexibility of the system, better bathtubs have jets that are individually controlled for spray direction, volume, and air/water mixture. The jets in well-engineered bathtubs are also nearly flush to the bathtub's interior.

However, there is a drawback to mixing air with water: The room's temperature will cool the bathwater. Additionally, the jet controls add another visual element to the bathtub. You should think about the overall look your clients hope to achieve as you recommend matching the whirlpool bathtub component parts to the bathtub finish (the most inconspicuous approach) or contrasting the bathtub finish and matching the bathtub fittings to the faucet finish specified elsewhere.

Bathtub Planning Tips from Bathroom Pros

Once the bathtub's equipment has been installed and the bathtub has been placed with the comfort, safety, and pleasure of the user in mind, the following special construction constraints must be considered.

Hot water requirements. The whirlpool bathtub relies on the hot water system installed in the house to fill the bathtub. Therefore, the existing hot water tank capacity and its recovery rate need to be verified before a bathtub is specified. At an initial filling, you can generally expect about 70 percent of the hot water tank's capacity to be delivered at the temperature set. Therefore, a 40-gallon hot water tank will deliver about 30 gallons (113.55 liters) of 120° F (48.8° C) water.

The recovery rate of gas hot water tanks is faster than electric tanks; therefore, if the initial drain is not adequate to fill the bathtub, the recovery rate must be taken into account. The manufacturer's literature will tell you how many gallons of water the bathtub will require.

The capacity of whirlpool bathtubs ranges from 50 to 140 gallons (190–530 liters) of water. A good rule of thumb would be to size the water heater to provide enough hot water for two-thirds capacity of the bathtub, with the balance being cold water.

If the existing tank is not adequate, you have three options:

1. Increase the size of the household water heater or install two water heaters side by side.
2. Provide a separate water heater specifically for the whirlpool.
3. Specify a tankless water heating system to service the whirlpool bathtub.

Tankless water heating systems. Water heating systems are covered in the *Kitchen & Bath Residential Construction and Systems* volume of the NKBA Professional Resource Library. However, when considering an oversize bathing pool or a large multi-head shower, designers should be aware of what the base requirements are and the opportunities of tankless water heating systems. These systems have improved dramatically in efficiency and have reduced in cost over the past several years.

The advantage of a tankless water heating system is that an unending supply of hot water is provided because there is no capacity-limiting tank. Therefore, the individual or gang series of 240-volt tankless water heating appliances can be used to provide the hot water necessary for oversize bathtubs or multi-head showers. The tanks are small but do require ventilation. Water delivery may be slowed if several water appliances are being used at once. The advantage is the constant flow of hot water produced on demand.

Water flow rate. Regardless of how much hot water is available, if the plumbing supply lines are not large enough and/or if the bathtub filler spout is not adequate, the water will not be able to fill the tub fast enough.

The secret to success is the diameter (size) of the pipe. Normally, ¾-inch nominal (inside dimension) hot and cold supply lines service a bathroom with three fixtures. The ½-inch nominal individual branches then bring hot and cold water to the standard bathtub fittings. A ½-inch spout is then used to fill the bathtub.

To provide the increased flow of water needed to fill bigger bathtubs, a ¾-inch individual water supply branch line and a ¾-inch bath spout and valve should be used to maximize the water flow to the bathtub. Remember, the entire system must be increased in size. If a ¾-inch valve is installed with a ½-inch branch line, or the reverse, the water supply will not be adequate. Alternatively, doubling up on the bathtub fillers may help get the water into the bathtub fast enough.

Accessibility. Be sure the bathtub you specify is not too large to get into the house, down the hall, and around the corner into the bathroom. In new construction, the bathtub is installed during the framing stage. However, in a renovation situation, a large bathtub may be difficult to maneuver into the bathroom. Find out how much the bathtub weighs. A single worker may not be able to lift the bathtub without help.

Designer Alert!

Aromatherapy, chromotherapy, hydrotherapy, and thermotherapy affect the user's well-being; therefore, how these therapies are engineered into well-designed bathing or showering products is important for the specialist to know.

Supporting the fixture. Typical North American floor systems are designed to carry 40 pounds (18 kilograms [kg]) of weight per square foot. Some large bathtubs may require additional support. Verify the weight of the bathtub when it is filled with water and people. If such information is not available, you can compute the weight as follows: 1 gallon of water equals 8.33 pounds (3.8 kg), and 7.51 gallons (3.5 kg) of water equals 1 cubic foot. Once you know how much the bathtub weighs when filled, determine if the existing floor joist construction is adequate to support the bathtub.

Water Therapies

Because of the growing importance of the master bathroom as an adult retreat as much as a place to get clean, clients today expect us to guide them through the selection process with a detailed understanding of wellness therapies.

A brief review of the therapies often requested by clients interested in such wellness treatments is presented next.

Aromatherapys

Aromatherapy is a form of alternative medicine that uses volatile liquid plant materials, known as essential oils (EOs), and other scented compounds from plants for the purpose of affecting a person's mood or health.

Aromatherapy is the supposed treatment or prevention of disease by use of EOs. Two basic mechanisms are offered to explain the purported effects. One is the influence of aroma on the brain, especially the limbic system, through the olfactory system. The other is the direct pharmacological effects of the EOs. At the scent level, they activate the limbic system and emotional centers of the brain. When applied to the skin (commonly in form of "massage oils," i.e., 1 to 10 percent solutions of EOs in carrier oil), they activate thermal receptors, and kill microbes and fungi.

Although aromatherapists often claim precise knowledge of the synergy between the body and aromatic oils, the efficacy of aromatherapy remains to be proven. However, some preliminary clinical studies show positive effects.

Some manufacturers have added a diffuser to a bathtub offering an aromatherapy feature. The user places a few drops of oil mixed with water into the diffuser. A small pump brings air to the diffuser receptacle, which sends the aroma of the oil into the air.

Chromotherapy

Chromotherapy, sometimes called color therapy or colorology, is an alternative medicine method. Therapists trained in chromotherapy believe the use of color and light can balance energy wherever our bodies are lacking, be it physical, emotional, spiritual, or mental.

Chromotherapy uses the visible color spectrum. (Therapists consider this to be the cosmic electromagnetic energy spectrum.) These visual colors, with their unique wavelengths and oscillations, are selectively applied to impaired organs or other body systems with a light source to provide the healing energy. Trained technicians believe colors generate electrical

impulses and magnetic currents or fields of energy that are prime activators of the biochemical and hormonal processes in the human body.

In the bathroom, two or more underwater LED lamps let the bather enjoy the full rainbow of colors, or select one to set a mood. Alternatively, overhead chromatherapy lights can be included in the showerhead itself or installed as a recessed ceiling fixture. Each LED light color enhances the bather's experience in a different way.

- White purifies the spirit and offers refreshing peace. It is used to relieve headaches.
- Blue is the source of true relaxation. It calms in stressful times and is indulgent to the senses.
- Aquamarine offers balance and relief from inflammation.
- Green calms the mind, body, and soul. It provides both relief and stability.
- Orange soothes a sore, tired body. It stimulates circulation and the respiratory system.
- Red stimulates and rejuvenates. It creates a mood of excitement and activates circulation.
- Purple promotes a true sense of tranquility. It reduces anxiety and detoxifies.

Hydrotherapy (Hydromassage) and Effervescent (Bubbles) Massage

Since the ancient Greeks, people have found natural healing powers in bubbling pools of hot water. The heat, buoyancy, and massage found in the warm, soothing waters of a jetted tub experience are both relaxing and rejuvenating. New shower systems offer a similar hydrotherapy experience.

Both bathing and showering hydrotherapy systems relieve stress. Stress has more adverse effects on health than many people realize. Some researchers estimate that nearly 80 percent of all diseases are stress related. Stress makes the heart work harder, breathing becomes more rapid and shallow, and digestion slows.

Hydromassage Experience (Jetted Bathtub)

Physicians and physical therapists also recognize the value of a massage water experience as an ideal environment for rehabilitation therapy. Muscle pain can be eased, fatigue overcome, and stiffness and soreness relieved when relaxing in a hydromassage tub. Body temperatures rise, which causes blood vessels to dilate, resulting in increased circulation and blood flow accelerating the body's natural healing properties. The reason the healing process is increased is that lactic acid and other toxins are replaced with oxygen. Endorphins, which serve as the body's natural painkillers, also are released.

In the past, such a hydromassage was limited to the bathtub. Today, new shower body sprays can deliver a variety of hydromassage therapies as well.

Effervescent Bathing Experience (Bubbles)

Relaxing in a bubbling tub bath stimulates the release of endorphins, the body's natural *feel-good* chemicals, giving the bather a sense of renewal and rejuvenation. The warm water and soothing massage also can help relieve anxiety and relax tense muscles.

Thermotherapy

Heat has been applied in various forms for therapeutic use for millennia. Sunlight, heated sand, and heated water were used initially as an effective means of therapy for ailments and pain. Early users of heat therapy also obtained heat from hot stones and coals, open fire, and hot irons. This type of dry heat is used in today's saunas.

The application of heat widens blood vessels and increases blood flow to the skin. Therefore, it relaxes superficial muscles, decreases muscle spasms, and reduces stiffness of the joints. Some research has also shown that it can block pain receptors for some individuals.

Moist heat appears to be more effective in treating pain than dry heat, as the moisture allows the heat to penetrate more deeply into the muscle. As the blood flows, local tissue metabolism

is enhanced. The improved blood flow lowers concentration of pain-producing toxic metabolites. This fact has resulted in the popularity of steam shower systems.

SHOWER STALL FIXTURES

Shower stalls are the ideal fixture for the daily showering ritual that is so much a part of North American life (see Figure 4.22). They come in many sizes and configurations (see Figure 4.23). The *Bath Planning* volume of the NKBA Professional Resource Library identifies minimum acceptable sizes and recommended sizes based on human ergonomic studies. The materials that shower pans (the floor and front curb of the shower) and enclosures are made of are the focus of this volume.

Types of Custom Pans

Masonry and stone. Masonry and molded-stone shower pans are available. Masonry pans are of a cement construction with chips of ground stone used as filler, much like terrazzo. (Terrazzo is a combination of white cement and marble chips.)

The mixture is poured into a mold and then subjected to high temperatures and pressure for curing. When removed from the mold, the pan has a smooth finish with a homogeneous wall structure.

Solid surface. Major manufacturers offer solid surface shower pans in popular sizes. Skilled fabricators can also create custom pans for you.

Plastic. Fiberglass reinforced gel coat, acrylic and ABS plastic shower pans are available. See Chapter 3, "Fixture Materials," for a detailed description of how this material is manufactured.



FIGURE 4.22 In many renovation projects, a walk-in shower replaces a bathtub/shower combination.

Courtesy of American Standard

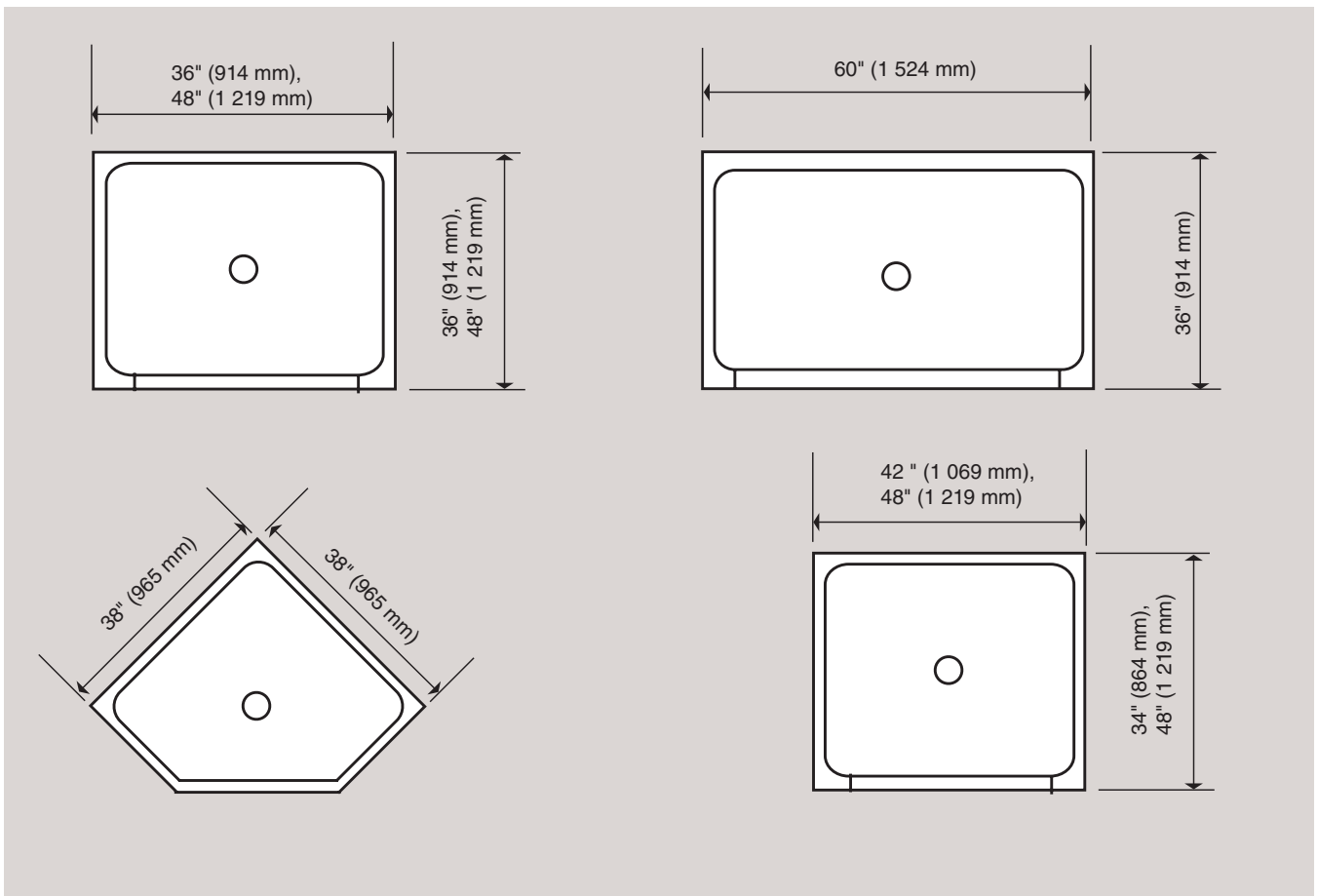

FIGURE 4.23 Typical stall shower configurations.

Cast polymer. Cast polymer shower pans are also available. The manufacturing process for this material is discussed in Chapter 7.

Ceramic tile. Ceramic or porcelain tile can be used as the shower pan base. The tiles need to be scored so the ceramic product can be slanted to the drain. When you are planning a ceramic tile pan, you have complete flexibility in size and shape of the enclosure. You also are responsible for making sure the pan is watertight.

These last four types of pan materials offer an added advantage. The walls in the surround can be made out of the same or similar surfacing. With plastic materials, the enclosure can actually be made in one piece with no seams. These one-piece units can be attractively sculpted to include built-in grab bars, grooming recess areas, and reclining seats.

To Curb or Not to Curb?

Curb Shower

A shower enclosure can have the base (floor) at the same level of the balance of the bathroom if it uses a traditional shower curb. This is a raised frame separating the shower base from the balance of the shower floor. This installation typically uses a traditional shower drain connected to the waste lines.

Curbless Shower

If the shower pan (floor) can be lower than the bathroom floor, allowing it to slope to the center or to a rear or side wall of the shower enclosure, it can be installed with no curb, as shown in Figure 4.24. In fact, some curbless showers are installed with no glass enclosure.

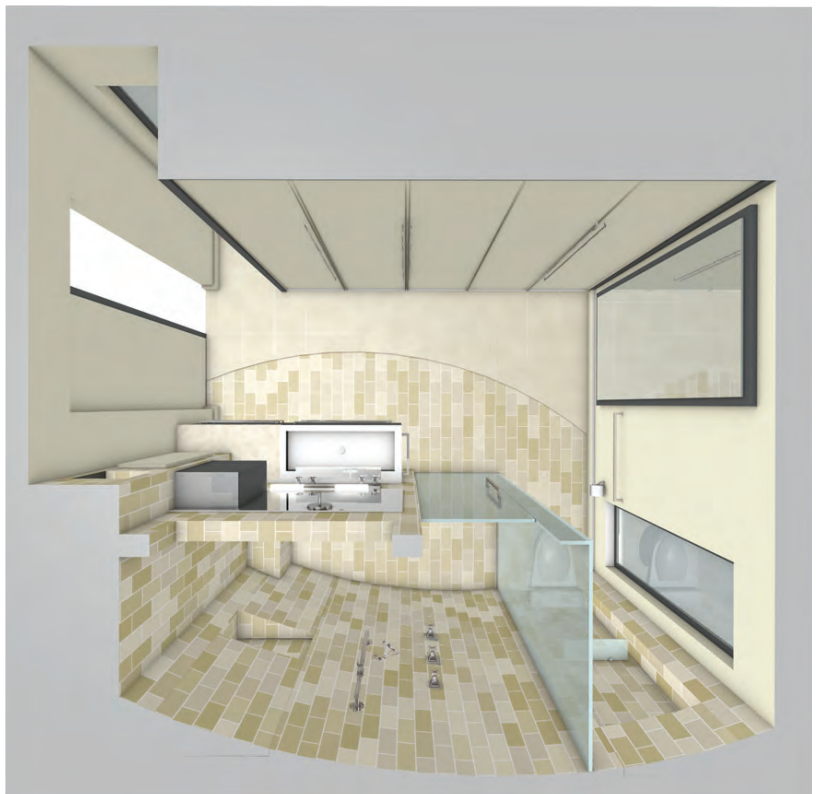

FIGURE 4.24 A curbless shower installation: A custom shower can eliminate the curb when an elongated infinity drain is included in the space.
Design by Beverley Leigh Binns. Photo by Tim McClean

A specially designed drain called an infinity drain can capture a large volume of water quickly and must be used for curbless showers. The floor in a curbless shower is slanted toward the infinity drain so that water moves quickly.

Providing a Safe Showering Environment

Designers should include a simple footrest or a bench in a shower enclosure. The footrest can be a simple triangular item.

A bench is much more preferable. It should be sized according to the user's stature. It should be planned in a matte or texture material, so it provides a nonslip surface. It needs to be supported to carry the weight of one or more adults who may be using the shower individually or together. Some prefabricated shower units include a bench that slides along a captured channel at the back of the shower enclosure, allowing for some flexibility.

Shower Accessory Systems

Within the shower enclosure, there should be a planned surface-mounted or recessed accessory to hold the expected bathing and grooming items. Surface-mounted accessories should be installed away from the water flowing from the shower. Ideally, they also should be located away from the entry or exit point of the shower to minimize any accidental contact. Accessory storage shelving systems can be recessed into the wall in material matching the enclosure wall or contrasting to it.

The Shower Enclosure: Innovations in Glass

A shower is a compartment that is enclosed on four sides. One side of the shower typically contains the piping and fittings to provide one or more streams of water. The solid material may be on a second or third wall as well. The fourth wall may be simply open to the bathroom space: this is called an *open* or *doorless* shower. More often, a glass door completes the four-sided enclosure.

The shower door may span wall to wall and be hinged. The door configuration may consist of a fixed panel of glass and the hinged door.

In a larger enclosure, or in a combination bathtub/shower, the door might be a sliding door opening at both ends. The sliding mechanism may be within a channel at the top of the enclosure or might be a surface-mounted sliding system, sometimes referred to as barn door hardware.

Alternatively, a shower or a combination bathtub/shower can feature a *spray panel*: a single stationary or hinged panel mounted to the wall housing the showerhead. The spray panel does not totally enclose the shower or bathtub/shower combination.

The glass door/wall enclosure portion of the shower can be encapsulated in a metal frame or can be frameless.

All shower or shower/bathtub combination glass enclosures are fabricated from tempered glass. To qualify for approval as tempered glass shower doors, the glass must be processed so that should it be fractured, the entire panel will disintegrate into small granular pieces rather than large chunks with sharp edges.

Tempered glass is used in any glass installation where human contact is anticipated. Because of the added strength of the glass after tempering, it is cut before the process begins; therefore, if a custom shower enclosure is being ordered, there may be an extended lead time from template to installation. The process of making tempered glass starts by heating the glass sheet at approximately 1200° F (649° C), followed by blasting the exterior glass with high-pressure cool air. This forces the exterior glass to cool very quickly, while the interior glass cools more slowly. The result of this controlled process is a glass product with added strength caused by the tension and compression of the different internal and external cooling process.

Glass panels for the enclosure are cut to size before the tempering process. After tempering, glass cannot be cut; therefore, for custom door/panel designs, a template is made after all wall and floor surfaces are installed to make sure the custom enclosure fits properly.

In addition to traditional glass, less green low-iron glass is available. Glass that has a low-maintenance coating is also on the market. This treated glass seals the pores on the glass panel so that water beads up and rolls away. Untreated glass is porous. Therefore, during the showering process, as water splatters on the panel and then dries naturally, some waterborne minerals or scale will remain behind in the glass pores. Over time, it becomes impossible to remove—that is why old shower enclosures seem to have a film on them. When properly cared for, treated glass will stay bright and beautiful. Glass is available in clear form, textured, patterned, and colored.

Planning Tips from Bathroom Pros

Make sure you can get it in the house. When selecting a one-piece shower or a one-piece bathtub/shower combination, you must remember to verify hallway widths and door openings in a remodeling project. Typically, these fixtures are put in place during the framing stage in new construction. However, in a renovation scenario, the shower must be moved through finished spaces. Therefore, units that feature a separate pan and three walls typically are specified.

Specify the drain location. The drain location of all premade pans is determined by the manufacturer. It is typically in the center of square or round enclosures and off to one side in rectangular units. The location of the drain needs to be clearly specified on the plans to assist the plumber during the rough-in stage. Compare the existing drain in a renovation situation with the specifications for a new pan to make sure they are compatible.

Specify the curb. All of the man-made material pans are designed with a ledge at the front, which is called a curb or a threshold. Much like a recessed bathtub, the other three sides of the pan have a raised lip or tile flange so the water-resistant drywall can sit on a ledge rather than extending all the way down to the pan. This minimizes the problem of water wicking up behind the drywall and behind the surrounding finished wall surface material.

BATHTUB/SHOWER COMBINATION UNIT FIXTURES

As you will learn when you read the *Bath Planning* volume, combination bathtub/shower units do not provide a comfortable bath or the safest showering experience. However, in the real design world, often we are limited to this sort of combination fixture because of space constraints.

In many master bathrooms, a smaller freestanding one-person bathtub is installed to provide floor space for a larger walk-in shower (see Figure 4.25).

Selection Criteria

Bathtubs can be installed with a separate wall surface surrounding them. In this installation, it is always desirable to extend the wet-wall surround material past the end of the bathtub and then down to the floor. This protects the wallboard around the bathtub from water damage over the years of use.

Alternatively, the bathtub and wall surface materials can be the same, with the walls available in a separate panel configuration. This option allows the technician to bring the material into a small, difficult-to-reach bathroom and then complete the installation on site.

In room addition work or in new construction, a one-piece combination bathtub/shower can be installed. This choice provides a fixture that is the easiest to clean, the least susceptible to water damage, and the most flexible in its overall design. Today, manufacturers provide



sculpted units with benches and seats in large, oversize showers, fold-down seating areas in bathtub/shower combinations, built-in grab bars, and storage shelves all seamlessly formed.

FIGURE 4.25 This master bathroom includes a smaller bathtub to allow floor space for a large walk-in shower that can accommodate two people.

Design by Paul Knutson. Photo by Troy Thies

SUMMARY

An extremely wide variety of fixtures is available for your consideration when planning a residential kitchen or bathroom. It is important that you are familiar with sizes and configurations available, accepted installation practices as well as operational differences between products in each specific category. Additionally, it is helpful to learn from the experience of talented professionals who have been in the industry. Learning from the “Planning Tips from the Bathroom Pros” in this chapter can be very useful in your private practice.

The information we have covered is generic in nature. Designers should review specific products well represented in their marketing area. Creating a portfolio of products that you are comfortable representing is a far better approach when specifying individual pieces for a consumer than simply selecting items of interest on the Internet. The company’s reputation within the industry, years of business, location of the manufacturing facility, delivery capabilities—are all important considerations.

Typically, the products you represent will be featured in distributor showrooms or stand-alone business presentations. New products typically are presented at annual or biannual trade fairs or exhibitions. Studying the Internet to ensure your familiarity with the broad product offerings is a good place to start learning about fixtures. This research should be coupled with in-person inspection of the actual products you are considering specifying. This can be accomplished by attending local, national, and international trade exhibitions. Additionally, it is beneficial to develop an ongoing business relationship with distributors, representatives, or retailers of the products you will present to the prospective client for their consideration.

REVIEW QUESTIONS

1. Identify and describe the sink configurations available for a residential kitchen. (See “Kitchen Sink Configuration Choices” pages 154–155)
2. Identify and describe the lavatory configurations available for a residential bathroom. (See “Bathroom Lavatory Configuration Choices” page 157)
3. Discuss the planning concerns when specifying a vessel lavatory. (See “Vessel/Above-Counter Bowls” pages 163–164)
4. List three kitchen sink configurations. (See “Kitchen Sink Configuration Choices,” page 154)
5. Describe the WaterSense program as it relates to what a manufacturer must accomplish to display the logo. (See “Water Conservation Considerations” page 166)
6. Explain the difference in installation between a wall-hung toilet and a floor-mounted toilet. (See “Toilet Styles and Types” page 168)
7. Explain the difference between a gravity flush toilet and a pressure-assisted flush toilet. (See “GPF Toilets” page 170)
8. Explain the planning considerations appropriate for the residential installation of a bidet, a bidet/seat combination, and a bidet seat added to a standard toilet. (See “Alternative to a Bidet Fixture: Bidet/Toilet Combination Fixture or a Special Seat” page 172)
9. Describe the main configurations of bathtub fixtures. (See “Bathtub Fixtures,” pages 173–174)
10. Explain the difference between a jetted hydromassage bathtub and a perimeter air injection bathtub. (See “Perimeter Air Injection Bathtubs: Bubble Massage” and Jetted Bathtubs: Hydromassage pages 180–181)
11. Describe the process for transforming standard glass into tempered glass. (See “The Shower Enclosure: Innovations in Glass,” page 189)
12. Explain the difference between a shower with a curb barrier and a curbless shower base. (See “To Curb or Not to Curb” page 187)

Fitting Materials, Engineering, and Configuration



After the fixture materials have been selected, designers turn their attention to selecting the corresponding fittings. These water-delivering devices are called different names in different parts of the world and by different professionals in the construction and design community. Consumers in North America typically think of them as faucets and drains. Plumbing professionals might refer to them as trim or the rough-in valve or simply brass. The term “tap” is used in other parts of the world for any everyday type of valve, particularly the fittings that control water supply to bathtubs and sinks. It is the use of the word “tap” that has led to the term “tap water” as the standard name for water from a faucet.

Designers should always use terms their clients are accustomed to; therefore, in professional discussions, these fittings may be referred to as faucets, taps, or fittings.

This chapter discusses the base construction materials used to fabricate water-delivering fittings and describes the various finishes available for the designer’s specification.

Learning Objective 1: Describe the differences in construction materials and finish options as well as various configurations available for kitchen and bathroom faucets.

Learning Objective 2: Explain the differences among manual, sensor, and electromagnetic contact faucet controls.

Learning Objective 3: Categorize the various configurations of kitchen and bathroom faucets.

Learning Objective 4: Provide a comprehensive list of operational attachments available for kitchen sink and bathroom lavatory areas.

Learning Objective 5: Explain how fitting design impacts the temperature and volume controls of the faucetry.

The fittings available today have expanded from a single handle used to deliver cold or hot water, to mixing valves that deliver temperature-controlled water, to new fittings activated by a sensor system or electromagnetic touch technology. The differences in these new technologies are discussed.

There is a wide variety of faucet configurations as well as numerous functional attachments that are either required or can enhance the water delivery system. These options are detailed in this chapter as well.

This chapter also covers water control that is part of well-engineered fitting design, as it relates to establishing a variable comfort zone, controlling the volume of the water, and controlling the water temperature.

CONSTRUCTION MATERIALS

Brass

Brass is considered an excellent material for faucet construction because it is a strong, durable metal virtually unaffected by prolonged contact with water. Brass is an alloy of copper and zinc, with trace materials, such as lead, that improve machining or silicon to improve casting. It varies in color from yellow to red, and can be melted and poured into molds or machined from stock or rods.

Brass faucet bodies may be sand cast, much like a cast iron bathtub. Faucet component parts manufactured this way tend to have the lowest density and can be porous, which can cause pinholes and leaks. Because sand molds cool the brass quickly, this type of brass faucet must have the highest lead content.

Gravity die-casting is another way that brass faucets are manufactured. Molten brass is poured manually or injected automatically into a machined metal form. Waterways and other hollows are either machined or formed with a sand core. This method of casting provides greater density than sand casting but still must be inspected at the factory for pinhole leaks.

Forging is another method of forming faucet bodies from brass. In the forging process, a heated brass plug is pressed by extremely high pressure between two machined metal forms, which produces a smooth component part that requires little polishing. Waterways and other hollows are formed through machining. This process results in a fitting with few surface imperfections and a high-quality surface luster.

Last, brass stock, bars, rods, tubing, or thin sheets can be machined or cold stamped into desired forms and shapes. Again, minimal polishing is required, and low-lead-content brass can be used.

No matter what manufacturing process is used, brass provides a durable, long-lasting faucet material that stands up well. Even if the finish is damaged, the brass underneath holds up to heavy use. Because it is a costly raw material and involves complicated manufacturing processes, brass fittings are more expensive than fittings fabricated from plastic materials.

Copper

Copper is used for waterways of fabricated fittings and in some valve connections. Because it is softer than brass, copper can be shaped and bent easily. If uncoated, copper is prone to surface corrosion and scratching.

Plastics

Plastics—acrylonitrile butadiene styrene (ABS), acetal, chlorinated polyvinyl chloride (CPVC), and rubber—are smooth, relatively soft materials commonly used in valve systems and cartridges or the gasket material under the fitting. Some extremely low cost fittings feature plastic bodies or waterways. Plastic materials are inexpensive and not prone to a lime or scale buildup. The smooth, slippery surfaces ease the passage of water and debris, as opposed to rougher surfaces that can catch or slow such material.

Plastic valves can be damaged by line debris, such as sand and silt. Unless the plastic receives special preparation or is of plating grade, it is not as durable or strong as other materials, and

it is difficult to plate with special finishes. Additionally, it can be attacked by certain petroleum-based products.

Color matching plastic components to other components made from metal can be difficult due to the differences in texture, gloss, and light reflection.

Stainless Steel

Stainless steel does not need the additional finish that brass faucets do. Stainless steel faucets stand up well to high pressure, high temperatures, and potentially corrosive materials in the water supply. Stainless steel is more difficult to work with than brass, though, and is more expensive.

Zinc

Zinc is a silvery-white metal that is cast into forms and shapes. It is stronger and more durable than some plastics and smoother than brass. Therefore, it requires less polishing and buffing for a finished product. Zinc must be fully protected from contact with water by plating because it quickly corrodes and disintegrates if unprotected pieces come in contact with water.

PLANNING CONSIDERATIONS WHEN COMBINING FINISHES

Over the last several years, there has been a dramatic increase in technical innovations and finishing options available to the designer. While chrome finishes still predominate, modern faucets can be finished in nickel, brass, colored plastics/epoxy, stainless steel, gold, and living hand-rubbed finishes.

Many manufacturers offer a complete line of kitchen and bathroom faucet sets and coordinating accessories. These accessory items include towel bars, grab bars, and other accessories to match faucet offerings. Occasionally, a client will select specialized equipment that is not part of a full line product offering. Or a client may like one manufacturer's decorative bathtub faucet set and another company's accessories. Although various finishes will blend, if the client is expecting a perfect match, only one manufacturer's suite of products should be specified.

This problem is magnified if the client wants the colored fittings to match fixtures, wet walls, and counter surfaces made from other materials. For example, a client may expect the white epoxy-coated faucets to match the white solid surface countertop and the white acrylic shower stall. Because of the fixture and surfacing material composition differences, a match cannot be promised. Remember, a bathroom lavatory is china or enamel, the faucets have an epoxy coating, the wet walls/countertop solid surfacing is a blend of polyesters and acrylics, and the bathtub enclosure is an acrylic fixture. Talk to the client about colors blending with one another, not matching.

To overcome this color match dilemma, consider these solutions:

- Try to use only one surfacing material throughout the project. For example, in a bathroom, use solid surface materials in the shower and on the vanity top or ceramic tile on all surfaces.
- If your firm has a showroom, create a display setting that is all white. Make sure the whites on the floor, fixture, counter, walls, and fittings blend but do not match. This will give you a chance to explain the color variation to a client before the final project specifications are completed.
- Specify fittings that have a colored, chrome, or brass escutcheon plate separating them from the counter or wall. Such a color break will help camouflage slight differences in color tones.

Fitting Finishing Options

Chrome

Polished chrome. Polished chrome is the most popular finish for kitchen and bathroom fittings and hardware. It is extremely hard and does not oxidize in the air as do most other metals, thereby eliminating the need for regular polishing. Chrome is electrochemically deposited over the nickel-plated base metal. The nickel provides luster, brilliance, and corrosion prevention, while the chrome contributes color and tarnish resistance. It is a very bright and durable finish.

Brushed and matte chrome. A brushed finish is created by using a wire wheel to score the surface of the component part. This can result in a surface with sharp peaks and valleys that do not take the chrome finish quite as well during the plating process because the coating shears away from the peaks and accumulates in the valleys.

A matte finish produces a similar appearance without producing noticeable brush marks or the sharp peaks that are difficult for plating. This process is similar to sand blasting the components with fine glass beads to create a soft matted surface that plates better, to produce a finish as durable as polished chrome.

Nickel

Polished and brushed nickel finishes are popular. This finish is produced by a plating process called physical vapor deposition (PVD). Several other finishes also are applied with the PVD process.

PVD Finishes

Popular nickel, gold, bronze, and brass finishes today are created through a process developed by NASA called physical vapor deposition, referred to as PVD. These finishes are durable and designed not to corrode, tarnish, or discolor. The process embeds molecules deep into the faucet's surface, creating a strong, indestructible bond.

Differences in the alloys in the vapor deposited on the faucet yield different color finishes. Popular finishes today are:

- Brushed nickel and polished nickel
- Brushed brass and polished brass
- Brushed bronze, dark
- Brushed bronze, medium
- Polished gold

Figure 5.1 shows a bathroom faucet in several faucet finishes popular today. Figure 5.2 includes examples of popular kitchen faucet finishes.

Stainless Steel

Some manufacturers offer faucets made from solid stainless steel. Stainless steel does not stain, corrode, or rust as easily as ordinary steel.

Polished and Satin Gold Plate

For polished and satin gold plate, the highly polished brass product is first nickel plated, and then 24-karat gold is applied. Durability depends on the thickness of the gold layer. According to industry standards, plating to a thickness of less than 7 millionths of inch gold is *gold wash* or *gold flash*. Between 8 and 12 millionths is *gold plating*, and from 13 to 50 millionths is *heavy gold plating*.

All quality gold-plated fittings should fall into the latter category. Low-quality gold wash or gold flash is not durable and can wear after only three to six months of normal handling. It is very difficult to visually distinguish between high- and low-quality gold plate. Therefore, design professionals should review specific product specifications before recommending a gold-plated fixture.



FIGURE 5.1 Popular bathroom faucet finishes

Courtesy of Delta Faucet Company

Gold plate is available in either a polished or a satin finish. Given a quality plating job, both finishes provide good durability.

Quality gold will not tarnish. Maintenance of a satin gold finish is somewhat easier than polished gold because it hides marks better. The secret to long-lasting gold plate is to clean it only with a soft, damp cloth. *Never* expose gold plate to abrasives or acids as can be found in many commercial cleaners.



FIGURE 5.2 Popular kitchen faucet finishes
 Courtesy of BRIZO

Colored Coatings

A tinted epoxy coating is used to create a colored finish. The powder is sprinkled on (or a liquid is sprayed on) to the components and then baked at temperatures ranging from 375° F to 425° F (190° C–218° C) to provide thorough, even coverage and protection.

The coating can be scratched by mild abrasives, which results in an unattractive finish. The key is to clean and dry the faucet frequently after use to avoid the need for heavy cleaning and to never use an abrasive cleaner.

Living Finishes

Oil-rubbed bronze, weathered copper, and real brass are popular in rusticated environments. These finishes change with age. They are not coated in any way, and the finish is not expected to remain constant. They take continual care and cleaning. The copper sink shown in Figure 5.3 is an example of a living finish.



FIGURE 5.3 Living finish faucet: When a decorative finish is specified for the fittings, all sink accessories must be purchased from the same manufacturer to provide finish continuity.

Courtesy of ROHL

Rustic Finishes

Rustic finishes, such as pewter, copper, bronze, just to name a few, are available. These special finishes typically are used for bathroom vanities. Finish application methods vary by manufacturer; therefore, designers should consult with a plumbing product expert to learn how these faucets are finished.

KITCHEN AND BATHROOM FAUCET FITTING ENGINEERING

At the turn of the twentieth century, indoor plumbing systems brought water to the taps—one for hot water and one for cold water. The kitchen sink or bathroom lavatory was a bowl with a stopper at the bottom, to allow the user to fill the bowl with hot and cold water mixed from these two separate taps. It is not uncommon to see this type of system still in use around the world, notably in bathrooms.

In North America, hot and cold water is channeled through a mixing faucet, or common outlet or spout. The hot and cold water is regulated by adjusting two separate handles or by turning/pulling/pushing a single handle. Various manufacturers have proprietary methods of mixing water and specific materials within the design's internal mechanism of the faucet. Designers should familiarize themselves with specific product engineering features and benefits.

Fitting Activation Systems

Faucets can be operated by manually lifting, twisting, or turning handles. New hands-free technology is available. Two primary activation systems are available:

- Sensing technologies
- Electromagnetic technologies

Sensing (Touchless) Technologies

Sensing technologies have been used in public restroom lavatory faucets for a long time. These commercial faucets deliver water at a certain temperature and volume and are activated when the user's hands are placed underneath the spout or as the user approaches the lavatory. This type of operation also is available in residential bathrooms and kitchens. These faucets are battery operated and must be installed exactly as outlined in the manufacturer's installation instructions.

For kitchen faucets, the sensor may be on the top of the spout, underneath the spout on its arched area, or closer to the face of the spout. The user can wave a hand or an object, such as a pan or kitchen utensil, to turn the sensor on.

When investigating such hands-free sensing technology, designers should review product specifications to understand how the product can sense the user's existence, regardless of external factors, such as light reflection, clothing color, and textures or dryness of a person's skin. Some infrared technology works on intensity of light, which may detect outside influences, causing the faucet to activate unnecessarily. The best-designed sensing technologies provide consistent, dependable responsiveness of the faucets.

Electromagnetic (Touch) Technologies

Touch control faucets are activated when the human body meets any part of the spout or handle (see Figure 5.4) of the faucet when it is in an open position. The contact creates an electromagnetic pulse that sends a signal to the solenoid-activated valve installed underneath the sink along the faucet piping. Much like the touchless sensing faucet, it is powered by a battery pack. These faucets can tell the difference between a touch and a push. Manual operation is always available.

Both touch and sensing touchless faucets are controlled by the solenoid valve that is part of the faucet assembly. The diaphragm of the solenoid valve uses a rubberlike disk to control water flow. The valve is normally held closed. Then, in response to the sensor's signal that something is present or to a tap by the user, the solenoid pulls the valve open so water can flow out the spout. It pushes the valve closed again when the sensor indicates the object is gone or when the faucet is tapped a second time.



FIGURE 5.4 Touch control faucet
Courtesy of BRIZO

As noted, it is critical that the manufacturer's installation instructions be followed exactly as detailed. The solenoid must be protected from contact with any other metal or in some cases in a sight line of metals. The installation instructions will give directions on the exact location of the battery box as well as the proper directional focus of the solenoid itself.

This is important technical information for the design professional to know. In the event a client calls complaining that an electronic faucet is not working, the first three checks to be made are:

1. Was the faucet installed according to the installation instructions?
2. Has the solenoid been accidentally moved or reoriented?
3. Is it time to replace the batteries?

Faucet Engineering

The performance of a faucet over its years of use is determined by the way it is engineered to control all aspects of water. In addition to understanding the design of the faucet, the professional kitchen and bathroom design specialist must understand how faucets operate. All faucets feature either a washer or a washerless design. Each manufacturer has detailed training material available to introduce you to its range of choices.

Water Control Considerations

Comfort Zone

Human beings are comfortable using water that ranges from 95° F to 105° F (35° C–40.5° C). The distance of the fitting swing within this comfort zone determines how much adjustability is offered to the user. The total distance of travel from cold to hot should be as great as possible. A handle with a 120-degree arc from the hottest setting to the coldest and with a 40-degree arc within the comfort zone from 95° F to 105° F (35° C–40.5° C) is a functional, safe fitting design.

Volume Control

Most single-handle faucets have a 15-degree lift from the off to the fully on position. Some faucets offer a 20-degree lift. This lift range starts with the valve in a closed position. At the top of the scale, the valve is completely open. The ideal faucet design allows the water flow rate to be increased gradually as the faucet valve is opened with a lift/twist/turn action. The water flow should begin at 1 degree off the lift and continue in a gradual increase that is in proportion with the degree of movement. This type of fine-tuning offers the user a faucet that is safe and easy to use. Unfortunately, some single-handle faucet designs do not allow the water flow to begin until the faucet reaches approximately 7 degrees of the movement. With this type of fitting, the user's range of control is dramatically decreased.

Thermostatic Water Temperature Controls

Temperature control technology is available today that senses the water temperature before it leaves the faucet spout. For some faucet designs, an LED light changes color to let the user know exactly when water has reached the desired temperature or if it is considered hot or cold. These new technologies provide a constant temperature (\pm 3–5 degrees) no matter what other water demands occur in the rest of the home. There will be no sudden (and unwelcome) increases or decreases in water temperature while using the faucet. Chapter 6 (see the section titled "Scald Protection Devices" under "Shower Fittings") includes more detailed information about temperature-controlling valves.

Kitchen Faucet Configurations

The kitchen faucet configuration is determined by the position and number of controls, the faucet location relative to the sink, and the inclusion of any special features such as special-purpose spray heads.

Number of holes required by the faucet:

- **Single-hole faucet.** A single handle control requires only one hole in the countertop. The water filler and the control mechanism are designed to function within this one-hole configuration. Its snout may or may not swivel.
- **Two-hole faucet.** The water spout occupies one hole, and the single water volume/temperature control occupies the second hole in the countertop.
- **Three-hole faucet.** The hot and cold handles are separate from the spout and require three holes. A variation of this theme is called a bridge faucet, which has a horizontal connector (bridge) joining hot and cold water sources, as seen in Figure 5.5. The bridge is a prominent design feature above the countertop or the deck.

Location of faucet (next to or behind the sink):

- **Wall mounted.** Faucets that are mounted on the wall behind a sink need to be located carefully so that they are properly placed above the kitchen sink and have a spout length specified so the water is deposited in the center of the kitchen sink.
- **Special-purpose wall-mounted faucet (pot filler).** These are typically wall-mounted, jointed faucets behind the range so that pots can be filled on the range top (see Figure 5.6).



FIGURE 5.5 Bridge faucet
Courtesy of ROHL



FIGURE 5.6 Pot filler water source
 Courtesy of Elkay Manufacturing Company

There are also deck-mounted pot filler faucets. Utilizing a pot filler without a sink does not provide the cook a nearby option to dispose of used water. Therefore, many designers combine a pot filler faucet or a pull-down/pull-out faucet with a small sink next to the range. Figure 5.7 shows a pot filler faucet with a sink alongside the stove.

Special-purpose spray heads:

- **Pullout and pull-down.** A hose or spray head emerges from the faucet spout, and the combination pulls down or out, increasing the faucet's reach. A button, lever, or toggle



FIGURE 5.7 A sink and faucet placed adjacent to the cooking surface provide a faucet to be used as a pot filler as well as a sink to drain liquids.
 Design by Pietro A. Giorgi, Sr., CMKBD



FIGURE 5.8 Pro style faucet at a kitchen sink

Design by Joseph Irons, CGR, GMB, CAPS, CGP and Terence Tung, CKD

changes the water stream to a spray. How the spray head seats itself back into the main water spout is important to know: Better-engineered faucets have a magnet system. These systems securely hold the spray wand in place when not in use.

- **Pro style.** These sprays are oversize, large-scale pull-down faucets that bring a restaurant look into a residence. Typically they have a long hose or an elongated gooseneck with a spray head that offers choices of spray heights (see Figure 5.8). The oversize faucet may need to have a support bar holding it in place to the countertop or wall to provide rigidity.
- **Pivot.** The pivot faucet serves work centers opposite one another, as seen in Figure 5.9.



FIGURE 5.9 Pivoting faucet
Courtesy of Dornbracht Americas Inc.

Bathroom Faucet Configurations

As in the kitchen faucet configuration, the bathroom faucet configuration is also determined by both the position and number of controls and the location of the faucet relative to the sink.

Number of holes required by the faucet:

- **Single-hole faucet.** Single-handle controls are located above the spout or to the side of the spout. Single-handle bathroom faucets are available with different length spouts (see Figure 5.10). Be sure you specify the proper length for the planned use. Longer spouts are required when used in conjunction with vessel sinks.

The control is turned left or right, pulled up or down, or pushed front to back. These controls sometimes are confusing to individuals not familiar with their operation.

- **Two-hole faucet.** The water spout occupies one hole; the water volume and temperature controls are separate holes in the countertop.



FIGURE 5.10 One-hole faucet
 Courtesy of Dornbracht Americas Inc.

- **Three-hole faucet.** The water spout occupies the center hole with a hole to the right of the spout for the cold water faucet and a hole to the left of the spout for the hot water faucet (see Figure 5.11).
- **Four-inch center faucet set.** Small faucets are available where the spout and two separate handles are mounted on a metal base (called an “escutcheon plate”). Individual holes are concealed by the plate. The drilling is generally 4 inches on center for this type of faucet. Although this is generally an economical faucet, because the handles are very close to the spout, it may be difficult to clean. Unless it has lever handles, some people may find it difficult to use.



FIGURE 5.11 Three-hole vanity faucet
Courtesy of Dornbracht Americas Inc.

- **8- to 12-inch faucet set (commonly called widespread faucet set).** Some decorative faucets eliminate the escutcheon plate and separately mount the spout and two handles. The spacing is flexible and may be anywhere from 8 to 12 inches. These faucets are easier to use and care for than 4-inch center faucet sets.

Location of faucet (behind the sink):

- **Wall mounted.** These faucets are mounted on the wall behind a sink (see Figures 5.12 and 5.13). Wall-mounted faucets need to be carefully located so that they are properly placed above the bathroom sink and have a spout length specified so the water is deposited in the center of the bathroom sink. **Note:** Exact wall-mount faucet location and correct matching of faucet spout length and water trajectory is critical when specifying a wall-mounted faucet behind a vessel sink.



FIGURE 5.12 Single-handle wall-mounted bathroom faucet
Courtesy of Kohler Co.



FIGURE 5.13 Double-handle wall-mounted bathroom faucet
Courtesy of ROHL

Kitchen and Bathroom Sink Attachments

In addition to the sink having a variety of accessories available (detailed in Chapter 4), there are special attachments and/or enhancements available for the faucet.

Spout Shapes

The shape of the spout also affects the functionality of the sink. A gooseneck spout has a high arc and is ideally suited for a family that cooks in quantity.

Standard spouts are generally available in 10-, 12-, and 14-inch lengths. Longer spouts are needed for corner sinks, or if you are installing integral sinks in a countertop in a custom arrangement and separating them a bit farther than is the norm.

Spray Attachments

Special-purpose kitchen sink and bathroom lavatory faucets are available that include a separate spray attachment. A separate spray is connected to the water line underneath the sink.

Drinking Fountain

Several manufacturers offer a spout that can be turned so it is comfortable to use as a drinking fountain. This might be an ideal faucet design for a family where bathroom users wake up during the night for a drink of water. It is also a useful feature to use when brushing one's teeth.

Also on the market today are cold water taps, which are ideal for drinking water taps at secondary locations. These systems can be connected to a filtration system if your client has requested one.

Hot Water Dispenser

This accessory has a faucet that is connected to a small storage tank mounted below the sink. The tank is connected to the cold water supply line and a 120-volt household current. The dispenser tank stores enough hot water for instant coffee, soups, or tea, eliminating the need to heat water in the microwave or boil water at the range top.

Lotion/Soap Dispenser

Installed on the sink ledge or in a countertop, these units have a plastic bottle below the sink and a pump handle above the deck. Hand lotion or liquid soap can be conveniently available at the sink without unsightly bottles or jars sitting on the countertop.

Aerator

Most faucets include an aerator at the end of the spout that mixes air with water to minimize splash-back. When a project is finished, it is not uncommon for the client to complain that the water volume is not as high as it should be. Advise the client to unscrew the aerator and remove the sediment from the screen on a regular basis.

Air Gap

Many codes require a dishwasher to have an air gap installed at the sink to prevent any backup of water in the dishwasher. The air gap is a metal or plastic cap that sits on the sink and is connected to a hose that leads to the dishwasher. A second hose leads to the knock-out on the side of the food waste disposer.

The dishwasher drains through the tubing below the air gap. There are small openings on the air gap, so an overflow will drain into the sink. Warn the client not to be surprised if there is a gurgling sound in the sink as the dishwasher drains in the new kitchen that has an air gap.

The food waste disposer should be cleared after every use because the dishwasher will drain through the disposer.

Bathroom Lavatories

The lavatory drain fitting consists of a brass or plastic waste outlet into which a sliding metal or plastic stopper is fitted. A lever that passes out the side of the drain fitting is connected to a lift rod on top of the lavatory faucet. This rod is lifted to lower the stopper and allow the lavatory to be filled. It is depressed to raise the stopper and drain the lavatory. The stopper should be removed and cleaned periodically to make sure it does not become coated with soap film and/or other debris. Alternatively, a decorative push-and-turn drain fitting can be used on vessel sinks; this fitting may be connected to the water-delivering faucet.

Shutoff (Angle Stop) Valve

Hot and cold water is supplied through supply lines controlled by shut-off valves that are typically in the cabinetry below the kitchen or bathroom sink. In a bathroom featuring a pedestal sink, these supply lines, and the shut-off valves attached to them, are exposed; they are on either side of the pedestal base. Therefore, these plumbing lines must be finished to match the decorative fittings in the bathroom. This is easy to do if polished chrome is the featured finish. Other finishes may not be readily available in the required plumbing piping and valves.

Water Treatment System

In some areas of the country, it may be important for you to be familiar with water purification systems. The water quality of a home can be improved as it enters the house, or it can be improved at a point of use within the house (one of the faucets).

The issue of water quality and what equipment is recommended at the sink is covered in the *Kitchen & Bath Residential Construction & Systems* volume of the NKBA Professional Resource Library.

There are three broad categories of systems you should be familiar with. One includes installing a filter on the cold water line that leads to a faucet. The second focuses on mounting a filter on the faucet itself. The third method mounts a filter on the line that diverts cold water to a separate faucet.

The first two methods do not affect the overall equipment at the sink, but the last option does require a third and separate faucet. Make sure you know what type of equipment may need to be installed inside the sink cabinet—it may affect a tilt-down drawer head front, a pull-out towel bar, or a lower rollout shelf you are planning. Also, find out what electrical requirements and/or plumbing connections you need to specify.

Helpful Hints from the Pros

Positioning the sink holes. Locate faucet holes along the ledge of an under-mounted sink carefully; they need to clear the sink rim edge. For top-mounted sinks, lay out the hole drilling

carefully, with the faucet on site. Check hole spacing if using a two-handle faucet to ensure clearance.

Overall depth of countertops. Make sure you have enough room behind the sink for some of the oversize pro-style, more elaborate faucets. Faucets with controls behind the spout are particularly problematic and might be better placed diagonally to the side of the sink.

Extra-thick countertops. Special planning may be needed for oversize, thick countertops: The shank length of the faucet needs to accommodate the counter thickness.

Oversize sinks. If the faucet does not have a pull-down spray or a side spray, verify that the spout swivel has a wide enough arc to reach all the sink bowls. Two-handle faucets—including bridge-style faucets—may not work with some double-bowl sinks.

SUMMARY

This chapter included an overview of the fittings specified for residential kitchens and bathrooms. The information focused on core construction materials as well as finish options. We also included an extensive discussion about the configuration of kitchen and bathroom faucets and the operational attachments.

In addition to this technical information, planning considerations from practicing professionals are included. Such planning information is helpful to designers when specifying a fitting system that may include a variety of component parts.

The material also focused on safety and comfort, with a discussion about fitting technology that provides volume and temperature control for the user.

REVIEW QUESTIONS

1. Compare the durability attributes of brass versus plastic as a faucet construction material. (See “Construction Materials” pages 194–195)
2. What is the difference between finishing a bathroom faucet in brushed nickel versus stainless steel? (See “Fitting Finishing Options” page 196)
3. Define the difference between a bridge kitchen faucet, a single-hole kitchen faucet, and a wall-mounted kitchen faucet. (See “Kitchen Faucet Configurations” pages 201–202)
4. Explain the difference between a kitchen pot filler faucet and a gooseneck kitchen faucet with a pull-down spray. (See “Kitchen Faucet Configurations” pages 202–204)
5. Explain the difference between an aerator and an air gap attachment. (See “Kitchen and Bathroom Attachments” page 209.)
6. Explain the difference between a bathroom 4-inch center set and a bathroom 12-inch widespread faucet. (See “Bathroom Faucet Configurations” pages 206–207)
7. Identify the comfort range of hot water for typical human beings in both Fahrenheit and centigrade. (See “Water Control Considerations” page 201)
8. Describe how a valve provides temperature or thermostatic control. (See “Thermostatic Water Temperature Controls” page 201)

Bathtub and Shower Fitting Design and Engineering



Although kitchens and bathrooms share a category of fittings for the sink or lavatory, the bathroom has additional fitting requirements for bathing and showering. Therefore, this chapter focuses on these two specific bathroom water centers.

Chapter 5 includes information on fabrication, finishing, and water control systems. This information is applicable for fittings specified for bathtubs as well as showers and is not reviewed again in this chapter. Because of the importance of water temperature control in showering activities, this chapter includes additional information about scald protection devices.

In addition to detailing the types of fittings available for bathtub and showers used daily, this chapter includes information on two additional specialty water therapy environments: steam rooms and sauna spaces.

Learning Objective 1: Detail the water delivery and removal fitting and system component parts for bathing and showering.

Learning Objective 2: Explain how fittings can protect the user from scalding hot water.

Learning Objective 3: Provide a description, with detailed drawings, of popular types of multihead shower enclosures.

Learning Objective 4: Review basic planning considerations for steam showers and saunas.

BATHTUB FITTINGS

Bathtub fittings include the valve, the spout, and (as a separate component) a wastewater component and an overflow protector. A separate hand-held personal shower may also be included for the bathtub.

Bathtub Valve and Spout Configurations

The bathtub valve may serve the bathtub only or may include a diverter, which transitions the water flow between the bathtub and an overhead shower. We first discuss valving for a bathtub that offers only a bathing experience.



FIGURE 6.1 An alcove bathtub/shower combination with partial glass shower panel

*Design by Cindy McClure, CKD, MCP, CGP, codesigner DC Design House
Photo by John Tsantes*

The type of bathtub it is serving determines the component parts of the valve.

- **Bathtub in an alcove.** The valve and spout normally are mounted on a wall at one end of the bathtub. The valve is typically a single-handle control. Figure 6.1 shows an alcove bathtub with a partial glass panel while Figure 6.2 shows an alcove bathtub enclosed by a shower curtain.
- **Bathtub under-mounted in a platform or top-mounted on a platform.** The valve and spout are installed in a specific location according to the bathtub's design for top-mounted installations. The valve and spout may be placed anywhere along the deck perimeter if the bathtub is installed below the deck surface. The most popular valve configuration has three separate component parts.

Separate hot and cold faucets mix the water, which enters the bathtub through a specially designed spout. Size the spout to extend over the bathtub. Based on ergonomic planning considerations, the valves should be placed away from the center of the bathtub. The bather then has more clear deck space to enter the bathtub safely.

- **Freestanding bathtub.** Both contemporary and traditional freestanding bathtubs are available. They may be placed close enough to a wall to be partnered with a traditional wall-mounted bathtub valve and spout. Alternatively, a tower can be built to accommodate the traditional bathtub and valve configuration (see Figure 6.3). More commonly, these freestanding bathtubs are served by a floor-mounted filler system (see Figure 6.4). It may be designed to be a sturdy, single-column apparatus with bathtub spout and filler, accompanied by an adjacent hand-held shower. It also is available in very traditional two- or three-post systems. The designer and installation team should carefully review the manufacturer's installation instructions before the bathroom's rough framing or floor material is finalized to make sure proper support is provided for the fixture's tower.

Mounting the Fitting

In addition to making sure the supply line, valve, and spout are correctly sized to fill the bathtub in a reasonable amount of time, be sure the spout and valves can be properly connected on the fixture rim or on the surface deck.



FIGURE 6.2 An alcove/bathtub shower combination enclosed with drape shower curtain

*Design by Cheryl Kees Clendenon.
Photo by Greg Riegler*

Most deck-mounted fittings require connection from underneath the finished deck. This means you must also plan access for future servicing. Some manufacturers now provide quick connect systems, which allow you to attach the deck-mounted spout more easily than in the past.

Make sure the overall deck ledge depth is less than the overall dimension of the spout outlet. Note that the spout might actually be part of the bathtub.

Hand-held Shower

A hand-held shower is one of the most useful fittings you can suggest for a client planning a bathing space. It makes washing hair in the tub or rinsing off much more pleasant. It is



FIGURE 6.3 A freestanding bathtub in a platform with deck-mounted fittings
Design by Brigitte Fabi, CMKBD.
Photo by Eric Hausman



FIGURE 6.4 Freestanding bathtub with floor-mounted bathtub fittings
Design by Christine Salas, CKD, CBD.
Photo by Brian Charlton/OBEO

extremely useful when bathing children or pets. In addition, it makes cleaning the bathtub much easier.

There are several systems from which to choose. The typical installation requires the use of a bathtub filler and a diverter valve to channel the water from the bathtub spout outlet to the hand-held spray. The diverter category offers two mechanical options: a rotary-action valve or a spring-loaded push- or lift-type valve. Bathtub valves with hand-held showers are outfitted with a vacuum breaker to prevent any backflow of used water into the potable house water supply system.

Wastewater Drain and Overflow Protector

There are two final elements to the bathtub fitting system. Wastewater is removed from the bottom of the bathtub by a drain located either in the center of the bathtub or at one end. An overflow protector fitting is located along the side of the bathtub: either at one end or in the center of a side wall. The overflow fitting limits the amount of water in the bathtub because when water rises to the overflow, it will begin to drain from the bathtub. Because the distance from the bottom of the bathtub to the waste overflow varies between fixture models, make sure you order the correct waste and overflow to fit the bathtub you have specified.

Types of Wastewater Drains

Pop-up and trip-lever drain. The standard North American pop-up or trip-lever types of waste and overflow are economical and fit most bathtubs. The trip-lever version has a stopper below the perforated drain. The pop-up version has a lift-up mechanism in the open drain. Either is activated when a lever is tripped or a rotary knob is turned.

Cable drain. An alternative is a cable drain that places no mechanical components in the tubular passageway of the system. Rather, a cable runs outside the system and connects the handle of the overflow to a plug-lift mechanism just below the outlet's flange. It is important to provide access to the plumbing wall behind the bathtub when specifying a cable drain because the mechanism is not accessible from inside the bathtub.

BATHTUB/SHOWER COMBINATION FITTINGS

The bathtub may also serve as a combination bathtub/shower. In this installation, the fittings include the bathtub filler/spout, a diverter valve that allows the water to be directed down to the bathtub spout or up to the showerhead and the showerhead itself. These three are typically installed on one common wall in a straight line. However, installations can be more elaborate with the addition of a hand-held shower. Therefore, designers should be familiar with the preceding information on bathtub fittings and the information that follows regarding shower fittings when planning a combination bathing/showering enclosure.

Diverter

The diverter for a bathtub/shower combination can be a pull knob on top of the bathtub spout, a push or turn handle diverter placed between the hot and cold valve on the wall, or a button diverter on a single-handle shower control. A multihead shower enclosure may also have a diverter fitting if the showerheads are not used at the same time.

The section titled "Shower Fittings" presents a detailed discussion of shower fittings that are appropriate for either a separate, stand-alone configuration or a bathtub/shower combination.

Access to the Pipes

In all installations, shutoff valves service the supply lines. In many installations, an access panel, as illustrated in Figure 6.5, is included so these shutoff valves are accessible in a closet behind

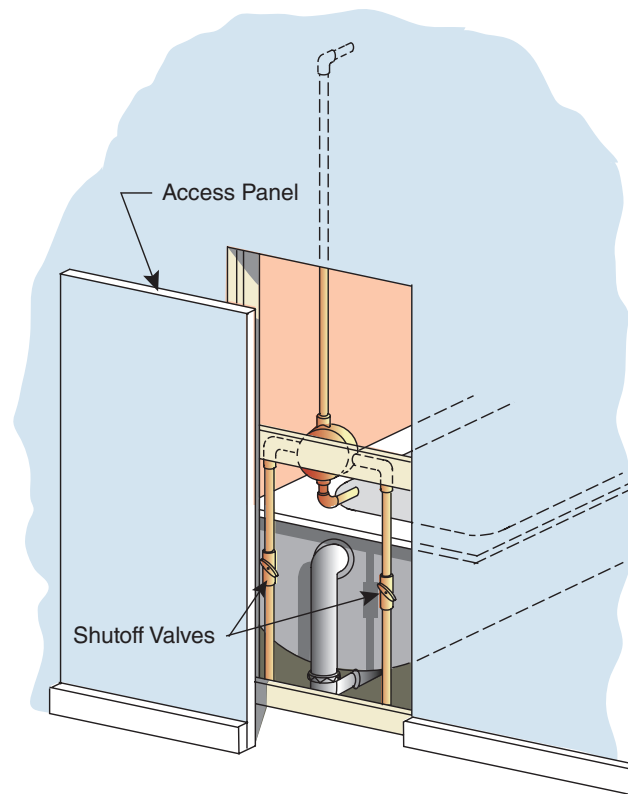

FIGURE 6.5 Bathroom fitting design: Bathtub/shower piping. Provide access to the bathtub/shower piping in a wall at the end of the fixture.

the bathtub or through an access panel in the wall that is camouflaged behind a piece of furniture. Alternatively, some have shutoff valves that are accessible from underneath the escutcheon plate. This feature eliminates the need for an access panel.

SHOWER FITTINGS

Safety in the Shower

Before we discuss shower valve or head placement, let us return to the issue of safety in the bathroom. The bathrooms you design must be functionally and ergonomically correct, and they must be safe.

The bathroom is one of the most dangerous rooms in the house. One source puts the number of scalding injuries alone in North America at more than 150,000 each year. Remember, children have thinner skin than adults have and are more easily burned in less time and by lower-temperature water. Additionally, showers and bathtubs ranked third among products associated with death among people 50 years of age or older due to slipping or falling.

Scald Protection Devices

Scalding accidents can be eliminated. Scald protection valves are available. Currently there are four broad categories of fittings that offer such protection.

Pressure-Balancing Valve

A pressure-balancing valve adjusts the mix of the hot and cold water in response to changes in relative supply inlet pressures. The valve compensates for the reduction of pressure in one supply line by increasing the flow coming from the supply and/or reducing the flow coming from the other supply. This type of valve does not compensate for changes in the temperature of hot and cold supplies. Therefore, the valve would not react to water temperature changes that occur because of a diminishing hot water supply.

Thermostatic Valve

The thermostatic valve system adjusts the mix of hot and cold water in response to changes in temperature. It automatically adjusts the flow of hot and cold water to maintain a relatively constant temperature. It can be slow to respond or it can briefly overcompensate for changes in supply pressures. This means you may have one to two seconds of a noticeable temperature change as the water supply cuts off or as the valve adjusts. This valve will supply a constant temperature shower because it will adjust the cold water supply as a reaction to a diminishing hot water supply.

Combination Valve

A combination valve combines pressure-balancing and thermostatic controls. This system compensates for both temperature and pressure fluctuations of supply inlets.

Temperature-Limiting Valve

A temperature-limiting valve is a high-temperature-limit stop that is adjustable by the installer or a family member. The high-temperature-limit stop prevents scalding by limiting the temperature of the water that can pass through the valve. The device is located under the lever and escutcheon of single-handle faucets and requires a simple screwdriver for access. A limit can be set for the hot water temperature delivered at the faucet and can be adjusted as the family's life stage and safety standards change.

All of these systems are designed for use with a showerhead minimum flow rating of as low as 1.5 gallons per minute (gpm). They perform under supply pressures up to 125 pounds per square inch.

Any well-designed bathroom today should include pressure-balanced or thermostatically controlled valves at the shower and/or bathtub/shower combination. Check local codes as these may be required in your area.

Basic Shower Components

Pan with Drain

The shower enclosure will have some type of a base. This base may have a curb that the user steps over as well as a perimeter wall to protect against moisture damage (see Figure 6.6). These types of pans may be made from formed plastics, solid surfacing materials, or other types of man-made products. Alternatively, the pan may be constructed out of ceramic tile. They may be minimal in size, or they may extend up the shower walls and include a bench or footrest.

A more detailed description of types of custom pans as well as planning considerations for curbless shower pans, as seen in Figure 6.7 and Figure 6.8, is included in Chapter 4.

The Valve

Manual mixing valves. Basic mixing valve options available for the shower are similar to those previously discussed for the lavatory: two-handle faucets and single-control faucets.

Electronic mixing valves Available for faucetry at the sink as well, electronic mixing valves are highly desirable in a shower. The valve acts as an electronic thermostatic valve because it maintains the temperature that has been programmed in by the user. When turned on, the unit always resets and delivers at an initial 98° F. Depressing either the up or down button shifts the readout display to the set point mode, causing the numbers to change in the direction of warmer or cooler until released. Once that button is released, the readout reverts to the actual temperature mode so the water temperature begins to move toward the selected setting and stops when it gets there. There is a hot limit device built into the valve as well as an integral pressure-balancing mode.

Shower Head

Water Energy Efficiency Dilemma

The U.S. Department of Energy limits the amount of water that can pass through a nozzle to 2.5 gallons per minute. This law was designed to limit both water and energy used to heat the water and to pump the water in a residential home. This limit of allowable gallons per minute has negatively affected the performance of the showerhead.

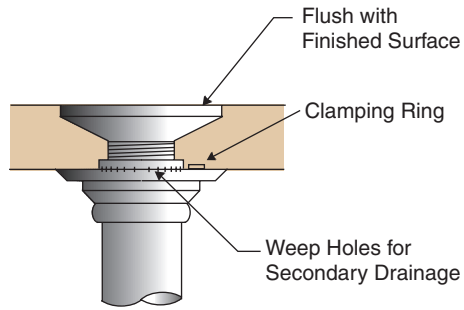
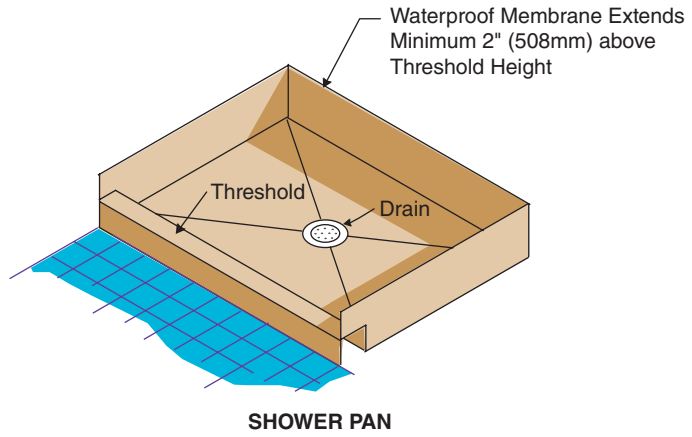

FIGURE 6.6 A shower pan and drain detail



FIGURE 6.7 A curbless shower without a door. Note the shower seat extending into the shower area.
Design by John Sylvestre, CKD. Photo by Karen Melvin Photography

There is a sporadic, ongoing discussion about governmental limitations extending to the number of showerheads allowable in multi-nozzle enclosures. Currently, the requirement is that each individual nozzle meets the flow capacity limit. There are no legislative limits on the number of showerheads within the enclosure. The discussion continues.

While the government limits showerheads to 2.5 gpm, Energy Star showerheads are available that only use 1.5 gpm. When originally introduced, these showerheads conserved water by highly aerating the water as it exited the showerhead. By simply mixing air and water, the user had the impression of a more powerful shower, but many complained there was not enough actual water to experience an acceptable shower. For example, rinsing shampoo out of hair took longer. Due to the increased surface space of the aerated water drops, the water temperature cools dramatically from the time it leaves the showerhead until it reaches the bather's body. Because humans are sensitive to a temperature drop of 2°, showerhead engineers have looked for alternative systems.

New Showerhead Technology

New technologies have been introduced that reduce the amount of water by changing the way the water and air is mixed (see Figure 6.9). Showerheads are now available that control the water droplet's shape, velocity, and thermal dynamics, resulting in larger water drops. These larger droplets retain their heat longer and provide a denser spray pattern. These showerheads may be quieter than conventional showers and do not include any moving parts. They are available in 1.5-gpm

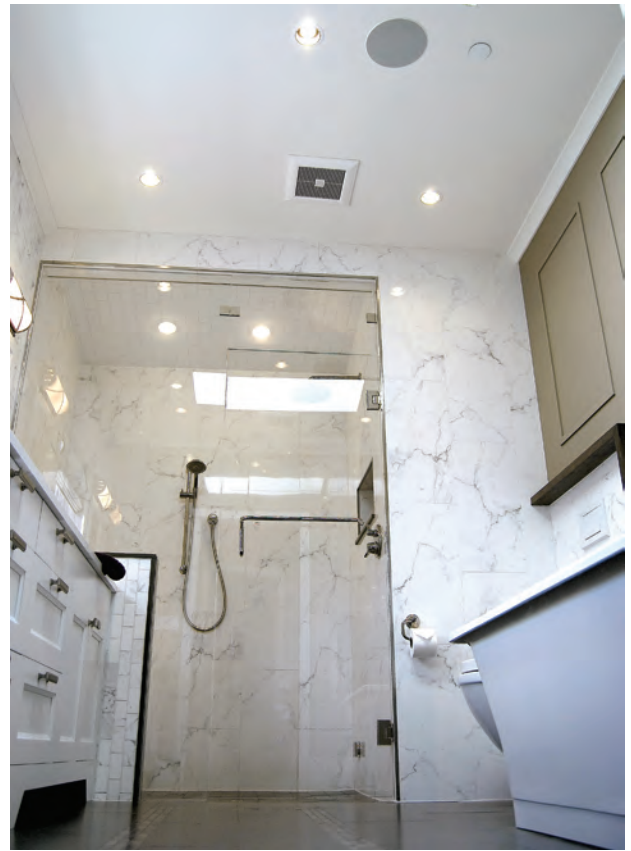

FIGURE 6.8 A master bathroom with separate freestanding bathtub and glass-enclosed shower

Design by Corey Shannon Klassen, CKD, CBD, codesigners Ian MacDonald, Scott Lumby. Photo by Jason Karman



FIGURE 6.9 Diagram detailing new technology that mixes air with water
Courtesy of American Standard

ratings, which results in a 36 percent decrease in water usage compared to the government-regulated maximum of 2.5 gpm.

Types of Showerheads

Ergonomic and usage considerations for showerhead design and placement are discussed at length in the *Bath Planning* volume of the NKBA Professional Resource Library. In this chapter, we identify the different types of showerheads.

There are numerous showerheads available today. Generally, there are four broad categories of showering options: personal hand-held shower, wall-mounted shower, overhead shower, and body spray shower.

1. Personal hand-held shower. The personal hand-held shower is ideal in showers used by people of varying heights as well as near a bench in the shower that is out of the stream of water (see Figure 6.10).



FIGURE 6.10 A hand-held shower can provide multifunctioning shower fittings.

Courtesy of ROHL

Hand-held showers are also a great addition to a shower used by an elderly person who may need assistance while bathing. Shower cleaning is also much easier with a hand-held shower. A hand-held shower can be incorporated into a wall-mounted showerhead as shown in Figure 6.11.

- 2. Wall-mounted shower.** The wall-mounted showerhead is the most typical installation (see Figure 6.12). It can offer several spray patterns, from a soft, gentle mist to a strong, invigorating spray. Some models integrate the personal hand-held shower into the center of the wall-mounted shower, simplifying plumbing yet offering two fixtures.
- 3. Overhead shower (sometimes called rain-head shower).** The overhead shower is placed on the ceiling. It may require a great deal of water to operate—check the manufacturer’s specifications.
- 4. Body spray shower.** A body spray is a group of individual showerheads, installed in a series of two or three, along opposite walls. They are normally directional, so the user can customize the showering experience.



FIGURE 6.11 Hand-held shower incorporated into a wall-mounted showerhead
Courtesy of BRIZO



FIGURE 6.12 A wall-mounted shower on an extended rod provides a water experience similar to a ceiling-mounted showerhead. The hand-held shower is installed separately.

Courtesy of ROHL

As a designer, you may be asked to incorporate various types of showerheads into your shower design, as seen in Figure 6.13.

Special Showerheads

Innovations are constantly being introduced to enhance users' showering experience. Chroma-therapy lights can be part of a showerhead. The showerhead can provide a speaker for the user's favorite music. Designers should confer with a plumbing fixture/fitting expert when working with a client who has expressed an interest in such new, innovative shower fittings.

Water Patterns

Sophisticated showering systems can be programmed to provide different water experiences in a selected sequence. These water options are typical:

- **Adjustment.** The basic spray adjusts from fine to coarse.
- **Spray pattern.** A full spray pattern is more desirable than one that only delivers water around the perimeter of the head, leaving a hollow in the center.
- **Water action.** Showerheads can offer a soft, gentle action, as seen in Figure 6.14, or a pulsating, invigorating massage.



FIGURE 6.13 Shower enclosure with wall-mounted, overhead, and hand-held showers

Design by Ada Pagano. Photo by Everett & Soule



FIGURE 6.14 Shower systems are available that allow the user to set the different water patterns.

Courtesy of Dornbracht Americas Inc.

Designing a Multiple-Head Shower Enclosure

When specifying multiple showerheads in an enclosure, ask this key question: Is this enclosure designed for one person to use with multiple heads that offer a variety of shower experiences or is it a shower enclosure with multiple heads that will be used by more than one person at the same time? The planned usage determines how the various showerheads are controlled and if they are sequential or concurrent (a choice between which showerhead to turn on versus the choice of having all or some of the showerheads on at the same time).

Determine How the Shower Will Be Used

If the shower is for one person, a diverter system can be designed to offer the user a choice of the various heads. For example, an overhead showerhead could be used in place of body sprays rather than concurrently. This type of arrangement is designed with one mixing valve and a diverting device to direct the water to the various heads.

Or several users may enjoy the shower together. When two or more showerheads operate at the same time, you must pay particular attention to the water pressure, the size of the piping and the flow rate of the showerheads, and the mixer and diverter device. Designers should select a multiple-head system engineered by the manufacturer, with detailed schematic designs and installation requirements. Figure 6.15 is a plumbing schematic for a multiple-showerhead shower enclosure showing imperial measurements while Figure 6.16 shows the same schematic with metric measurements. Figure 6.17 is another plumbing schematic of the same multiple-head shower design.

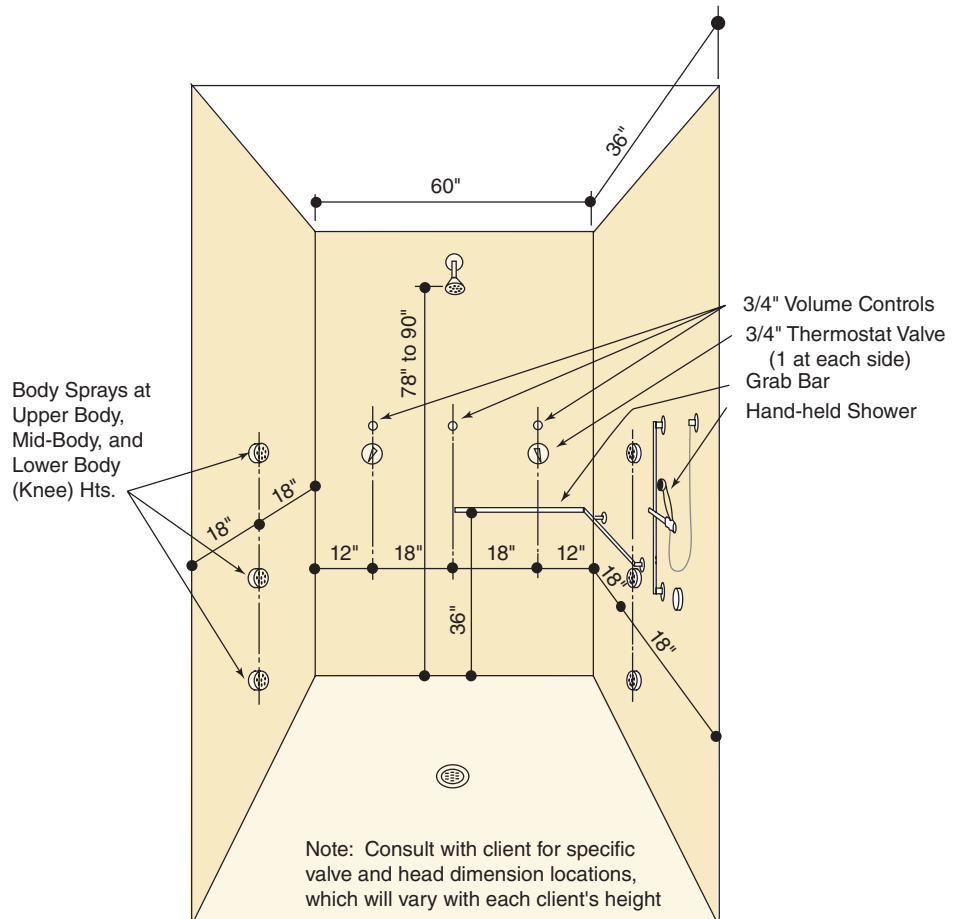

FIGURE 6.15 Plumbing schematic for multiple-head shower enclosure (Imperial)

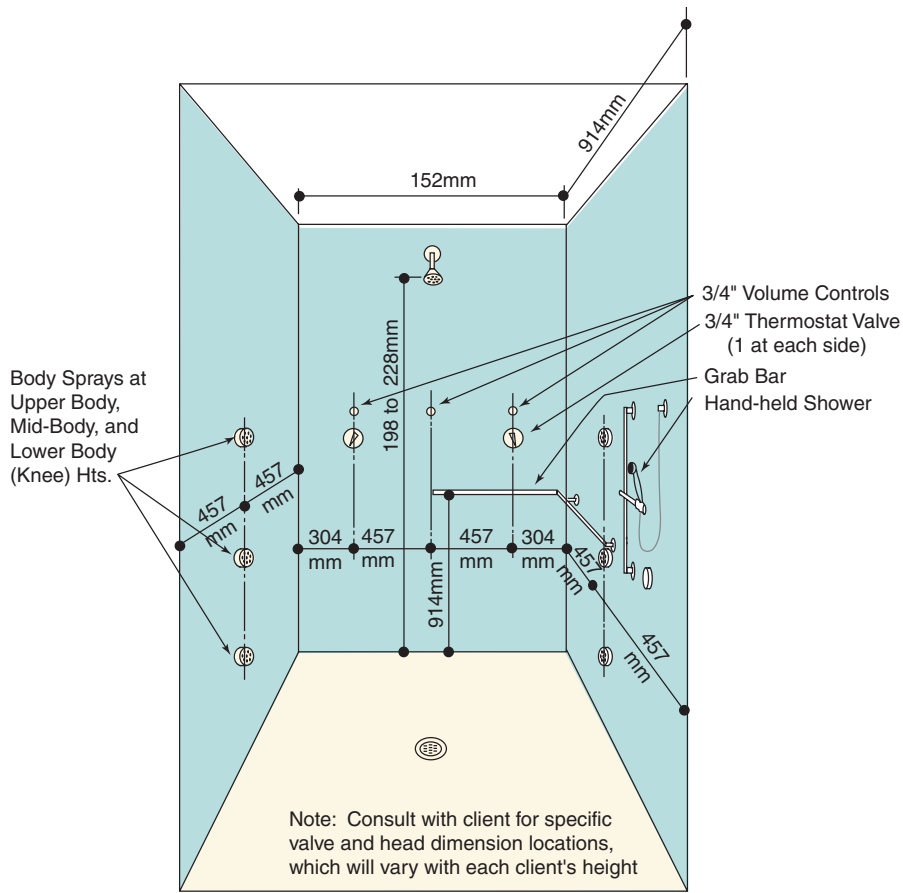

FIGURE 6.16 Plumbing schematic for multiple-head shower enclosure (metric)

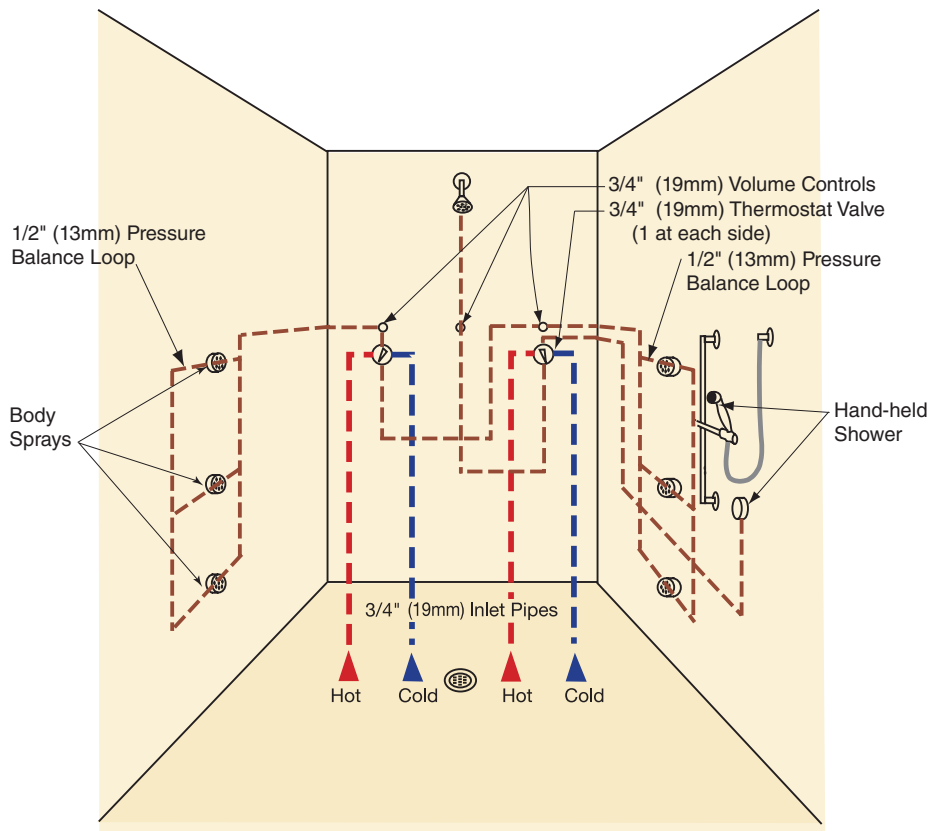

FIGURE 6.17 Plumbing schematic for multiple-head shower enclosure

Shower Tower

Both for the retrofit market and for custom enclosures, manufacturers offer shower towers connected to a single water source, as seen in Figure 6.18, which provide several or all of the types of showerheads just described as individual elements in one preengineered, pre-designed system. Although the initial purchase price is high, the installation is simplified and installation costs are reduced.

STEAM SHOWERS AND SAUNAS

Jetted bathtubs were discussed in Chapter 4. This chapter concludes with an explanation of steam shower planning criteria and sauna planning guidelines.



FIGURE 6.18 A shower tower incorporates all of the showerhead choices into a single fixture.
Design by Richard J. Farrell. Photo by Tim McClean Photography

Steam Showers

Steam showers are yet another way to provide a relaxing, refreshing experience. A steam bath invigorates the body's systems and cleanses the skin by opening the pores and flushing out the dirt. The normal steam bath lasts from 10 to 20 minutes in an enclosed environment with high humidity and temperature levels. Following a steam experience, a lukewarm shower can be taken to further relax, or a cold shower can be taken to stimulate the body.

In the past, steam rooms were available only at the finest private clubs and spas. Today, including a steam bath as part of a stall shower is an affordable addition to even a modest bathroom space.

The steam shower is energy efficient and does not require any more floor space than the stall shower you are already planning.

Enclosure Design

The next constraints and/or planning concerns must be taken into account when considering a steam bath.

Wet Wall Material

Avoid specifying any material that may be subject to decay due to prolonged exposure to steam or moisture. Verify with the specific manufacturers if their wall surfacing material is acceptable in a high-heat, high-humidity environment. Also, use a waterproof substrate material behind the decorative surfacing material you select.

In all applications, use waterproof adhesives or silicone sealants as well as waterproof or epoxy paint.

Glass

Specify a completely enclosed, vapor-proof door. Fixed or operable transom panels are available as an accessory to standard shower doors to enclose the space to create a steam environment.

Seat Design

Place any permanent or portable benches well away from the steam nozzle. A person sitting in the steam room can be burned by an unexpected burst of steam.

Ceiling Slant

Slanting the steam room ceiling away from the seating area is recommended. A slanted ceiling ensures that as steam condenses on the ceiling, it runs down the slant, away from the seated user. The ceiling should be 7' high.

Sizing the Generator

Choosing the appropriate generator is the most important factor for a functional steam room in the home. A properly sized and engineered steam generator produces steam in the enclosure very quickly.

The cubic footage of the enclosure determines the size of generator needed. The construction and decorative surfacing materials also affect the size of generator you specify. The surrounding temperature must also be taken into account.

- **Timer.** A timer will be included to limit steam generation.
- **Wall material.** The porosity level of the material selected affects the cubic footage formula used to determine the generator size. Common surfacing materials and their effect in the cubic footage calculations are as follows.
 - All glass or glass block: Add 20 to 40 percent to the actual cubic footage of the enclosure.
 - Ceramic tile on water-resistant sheetrock: Add 15 percent to the actual cubic footage.
 - Ceramic tile on cement board: Add 20 percent to the actual cubic footage.
 - Ceramic tile on mortar bed (mud) substrate: Add 25 percent to the actual cubic footage.

- Ceramic tile on cinderblock or concrete: Add 75 percent to the actual cubic footage.
- Fiberglass, acrylic, or cultured marble: Decrease the actual cubic footage by 20 percent.
- Natural stone, marble, travertine, or slate: Add 100 percent to the actual cubic footage.
- **Determine cubic footage.** When calculating the cubic footage of the enclosure, do not deduct for the bench area, since it requires nearly the same surface area. Remember, heat is lost to the surface area in a steam enclosure.
- **Surrounding temperature.** Ambient room temperature should be between 68° F and 72° F (20° C and 22° C).

If the steam room is installed against exterior walls, particularly in a cold climate, the walls should be insulated or the generator will need to be increased in size. Typically, it is recommended you add 10 percent to the generator size for each exterior wall, whether insulated or not.

- **Pipe run length.** Although the generator can be located in many different places, the closer it is to the steam enclosure, the better. (See Figure 6.19.) Some manufacturers will tell you it can be as far as 20 feet (6.10 m) away from the enclosure; others say as much as 50 feet (15.24 m). However, the farther the generator is from the enclosure, the longer it takes steam to get there. Add an additional 15 cubic feet (4.57 m) to the overall shower enclosure size for pipe runs between 15 and 25 feet (4.57 m and 7.62 m).

After you determine the cubic footage of the steam room based on these additional criteria, refer to a specification chart provided by the manufacturer to determine the proper steam generator model.

If the calculated cubic footage capacity falls between two models, always choose the larger unit.

Saunas

Explanation of Use

Although sauna procedures are as varied as individual users, most enthusiasts recommend briefly showering, then entering the sauna for 5 to 15 minutes. The individual may sit or lie in the insulated wooden room. The lower bench is always cooler than the higher one.

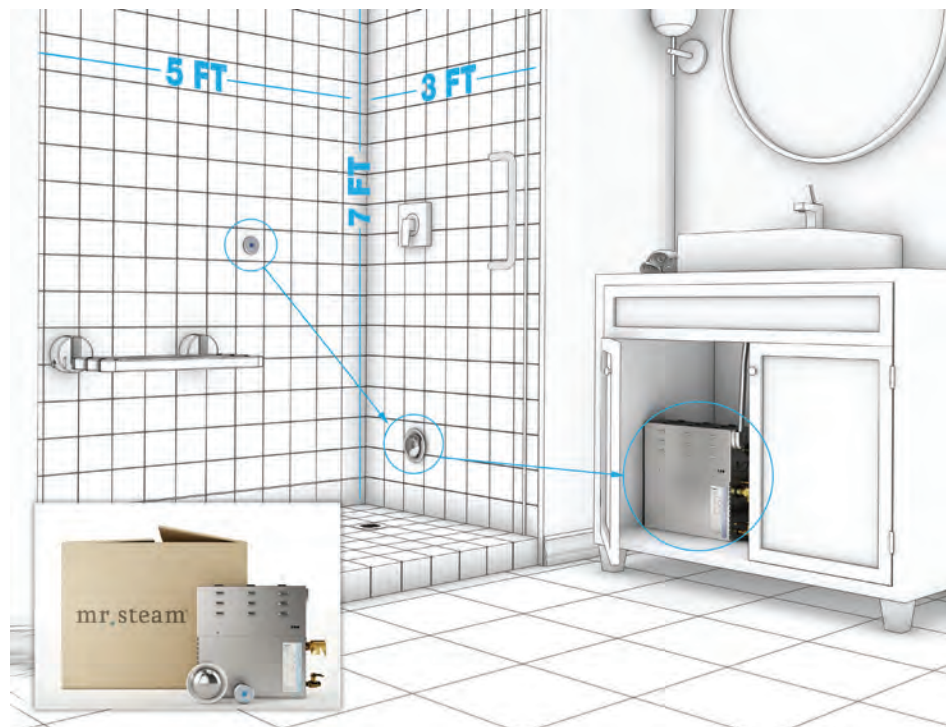

FIGURE 6.19 A steam shower
Courtesy of Mr. Steam®



FIGURE 6.19 (Continued)

Next, a cool shower, a swim in the pool, or a roll in the snow invigorates the body's system. A 10- to 15-minute rest follows. Finally, a second visit to the sauna for about 20 minutes is enjoyed. During the second visit, a brief whisking of the skin increases circulation.

Ladling water over hot stones can add a refreshing burst of humidity during the final moments. A second 20-minute rest is suggested, followed by a final shower and a light snack.

Enclosure Design Sizing Recommendations

Popular family saunas range in size from 4 by 3 foot to 6 by 6 foot shapes. Regardless of the overall shape, a 7-foot ceiling is recommended to prevent heat from rising into unused space. A door 1 foot 8 inches to 2 feet wide and 6 feet 8 inches high and swings out without any type of locking device minimizes heat loss and maximizes safety.

Because showering and resting are an integral part of the sauna experience, this specialty fixture should be located near the bathroom or swimming pool, with a dressing and resting area nearby.

Wall, Floor, and Ceiling Materials

The overall sauna enclosure generally is built out of wood. Although the traditional sauna uses aspen wood, kiln-dried, clear, all-heart, A-grade redwood is an adequate substitute for the modern day sauna because of its ability to withstand extreme temperature changes. Redwood acts as an insulator on walls, ceiling, and floor. In addition, it diffuses the heat so the surfaces remain warm, but not hot, to the touch.

Ventilation/Lighting

The sauna should feature soft, subdued lighting and good ventilation to prevent people from becoming dizzy. Prefabricated units offer an ideal design solution for sauna planning.

Manufacturers provide easy-to-assemble, well-thought-out systems that generally include these parts:

- **Intake vent.** Located near the floor in the wall behind the stove or installed in the sauna door.
- **Outlet.** For cross ventilation, located at the opposite wall approximately level with, but not below, the intake vent, or a few inches from the ceiling.

- **Lighting.** A lighting system that is soft and controlled from the outside of the enclosure. The fixture selected must be approved for a wet-room environment. This normally means it must have a cover, and may have a very low lumen rating.

Fuel Sources

A stove used in the sauna may be electric or gas. The proper kilowatt (kW) rating for electric heaters, or British thermal unit (Btu) rating for gas heaters, is based on the size of the sauna as well as the wall insulation and the location of the sauna in relationship to air-conditioned or non-air-conditioned adjacent spaces.

For example, for a sauna 5 by 7 feet installed indoors with good insulation, 1 kW of electricity per 40 cubic feet of room space is adequate. For a gas heater, 1,000 BTUs planned for every 15 cubic feet of floor space will also do the job. (Of course, the traditionalist client may select a wood-burning stove with a chimney.)

The sauna must also include a temperature control, located just outside the sauna room.

SUMMARY

Bathing and showering can be dangerous activities. According to one study conducted by the Center for Injury Research and Policy of the Research Institute at Nationwide Children's Hospital, more than 43,000 children 18 years and younger in the United States are treated in hospital emergency departments annually for injuries occurring in a bathtub or shower. The number of injuries remained consistently high over the 17-year study period from 1990 to 2007.

As a person ages, bathroom accidents become more common. Overall, mishaps near the bathtub, shower, toilet, and sink caused an estimated 234,094 nonfatal injuries in the U.S. in 2008 among people at least 15 years old, the Centers for Disease Control and Prevention reported. In addition, the injury rate rises with age. The report went on to state:

The highest rates were for injuries that occurred in or around the tub or shower (65.8 per 100,000) and injuries that happened on or near the toilet (22.5 per 100,000). The precipitating events in 37.3 percent of injuries were bathing (excluding slipping while bathing), showering, or getting out of the tub or shower; only 2.2 percent occurred while getting into the tub or shower. The precipitating event for 17.3 percent of injuries was slipping, which included slipping while bathing; 14.1 percent occurred when standing up from, sitting down on, or using the toilet.

A well-planned bathtub area or shower enclosure can provide a safe center for personal hygiene as well as restful, relaxing water therapy.

A word of caution is in order as we conclude this discussion of fittings for bathing and showering: Extreme temperatures stimulate the cardiovascular system. Individuals with high blood pressure, respiratory or heart disease, circulatory problems, or chronic illness, such as diabetes or epilepsy, should check with their physician about any concerns in regard to warm-water bathing or extended showering. A review by a physician is even more important for a client considering a steam room or sauna. In many cases, physical challenges will preclude an individual from enjoying these high-heat experiences. Additionally, pregnant women and individuals under the influence of alcohol or other drugs should avoid saunas or steam rooms.

Whatever your client's choice—a comfortable bath, a revitalizing shower, a relaxing steam bath, or sauna—designers are challenged to carefully question the prospective client, be well versed in product availability, and have an in-depth technical knowledge of the fittings and component plumbing parts required to create well-designed bathing or showering environments for the bathroom.

REVIEW QUESTIONS

1. What is the difference between a wastewater drain and an overflow protector in a bathtub? See “Wastewater Drain and Overflow Protector” page 215)
2. Describe the difference between a pressure balance valve and a temperature-limiting valve. (See “Scald Protection Devices” pages 216–217)
3. What is the name of the fitting used to reroute water from one showerhead to the bathtub filler or between showerheads in a shower enclosure? (See “Bathtub Valve and Spout Configurations” pages 211–212)
4. What is the difference among a hand-held shower, a body spray, and a ceiling-mounted showerhead? (See “Types of Showerheads” pages 220–221)
5. Why should a steam enclosure have a slanted ceiling? (See “Ceiling Slant” page 227)
6. What three elements of the design determine the generator size needed for a steam room? (See “Sizing the Generator” pages 227–228)
7. What are the key planning criteria for the entry/exit door planned for a sauna room? (See “Enclosure Design” page 229)

Surfacing Materials



In addition to cabinets, appliances, fixtures, and fittings in residential kitchen and bathrooms, another key ingredient of a successful project is the selected surfacing materials specified for the floors, walls, wet wall surrounds, countertop areas, and backsplash verticals.

Before selecting any of these surfaces, you must first understand the importance of a proper substrate material. The *Kitchen & Bath Residential Construction and Systems* volume of the NKBA Professional Resource Library covers the basic construction elements of a well-planned kitchen and bathroom. Once the proper substrate has been specified, the functional and decorative surfaces can be selected.

This chapter discusses the most popular surfacing materials for kitchens and bathrooms. Unusual, innovative, proprietary materials are continually being introduced. Design professionals should include time during their business schedule to research new products and regularly visit key suppliers to be current with newly introduced products as well as regional specialty offerings.

Learning Objective 1: Discuss attributes of primary surfacing materials, with a focus on how the materials are fabricated and what their recommended uses are.

Learning Objective 2: Detail specific design considerations when specifying the materials discussed.

Learning Objective 3: Explain the different categories of product offerings within broad groupings of surfacing materials.

SUSTAINABLE CHOICES

In addition to evaluating a surfacing material's appropriateness for a specific application and understanding the installation requirements of these surfacing materials, designers should also consider the sustainability of the material and the responsible management of the manufacturing company. Sustainability relating to wood products is extensively discussed in Chapter 1 of this volume.

Manufacturers of products in each of the broad categories discussed in this book have published extensive information about their manufacturing processes and the ecological friendliness of its materials. In well-managed companies, manufacturing techniques are constantly monitored and adapted to ensure environmental responsibility. From substrate materials to

topcoat specifications, companies meet or exceed requirements to eliminate hazardous air pollutants (HAPs) and volatile organic compounds (VOCs). The same attention to avoiding urea-formaldehyde products that is seen in the cabinet industry is an important part of wood-related surfacing materials.

Many products use pre-consumer recycled materials; some surfacing materials are actually created from recycled products. Within the manufacturing operation, better companies focus on reducing the impact they have on their environment through waste, energy, and emission management while focusing on safety for their workforce. When evaluating surfacing material possibilities, researching the company's sustainable practices is an important part of the selection process.

SOLID WOOD COUNTER SURFACES

Countertops are made from laminated or solid wood products. In addition to full countertops, insert blocks are often installed in the kitchen work surface.

The insert blocks are available in a variety of sizes and finishes. Both edge and end grain laminations are popular. In laminate countertops, an installation ring secures the wood section in place. A lip in the block can provide stability for a drop-in-place installation.

Some kitchens may feature the entire countertop in wood surfacing. When this type of countertop is planned, the designer must specify what type of wood will be used, what type of finish the block will have, and what water and heat protection the block will receive.

Several types of woods are available from different manufacturers:

- **Eastern hard rock sugar maple.** This wood is considered the hardest; thus cutting or scratching damage will be minimized.
- **Western maple; western alder.** This wood is not as hard as eastern maple and will be more susceptible to wear through, cutting, or scratching.
- **Walnut, cherry, or other specialty hardwoods.** These woods are sometimes specified in focal point areas that will not receive excessive use.
Grain patterns with the laminations will vary according to the fabrication procedure used.
- **Full-length edge grain laminations** feature long, unbroken strips of the wood laminated together. The edge widths remain constant.
- **Butt-joined edge grain laminations** feature various strips within the overall length of the top. The edge widths remain constant.
- **End grain laminations** feature a checkerboard effect of small squares of wood. This type of fabrication is normally limited to counter inserts.

The wood tops may be finished in several ways. The intended use of the block should determine the finish selection.

Unfinished Wood

The finish consists of oiling wood throughout the counter surface life span on a four- to six-week maintenance schedule. This method is most desirable if the entire counter surface will be wood and local fabrication of seams or miters is required. Prefinished tops hinder proper adhesion of seams and must be refinished if any sanding will be done (see Figure 7.1).

Prefinished Wood

The factory finish includes a penetrating sealer and a nontoxic lacquer finish. The combination of sealer and varnish prevents moisture penetration. No oiling is necessary, and a damp cloth may be used to wipe the board clean. Chopping on the surface may not damage the finish. This type of finish is appropriate for countertop sections, such as island tops (see Figure 7.2) or sandwich centers.

A wood surface can also be used to differentiate the seating area from the solid surface work counter, as in the design shown in Figure 7.3.



FIGURE 7.1 A rustic-style wood butcher block surface.

Courtesy of John Boos

Wood Sealed with Polyurethane

Polyurethane sealer is used on unfinished wood tops that will not be used as chopping surfaces and will not come in contact with food. The finish is very good on tops that will be exposed to moisture and liquids.



FIGURE 7.2 A butcher-block prep area is set into an island with honed granite countertop.

Design by Karen Williams



FIGURE 7.3 A section of an island countertop is finished in a rusticated wood with a coordinating wood support underneath it.
Courtesy of Jenn-Air, Design by Ellen Cheever, CMKBD, ASID, CAPS

CAST POLYMERS: COUNTER SURFACES AND WET WALL SURFACES

Cast polymers are used for bathtub fixtures, one-piece shower enclosures, three- to four-piece shower enclosures, and vanity surfaces, often with an integrated lavatory. In slab form, cast polymers can be used in bathtub and/or shower enclosures as well as for slab vanity tops (see Figure 7.4). They are available in marbled patterns, granite-like textured patterns, or solid colors.



FIGURE 7.4 Cast polymers are a frequently used material for bathroom vanity tops, showers, and bathtubs.
Courtesy of Accent Marble and the International Cast Polymer Alliance

Cultured marble, cultured onyx, cultured granite, and solid-colored polymer-based materials are all used for cast-mineral-filled polymer fixtures. Although generally referred to as cultured marble, a better term for you to use when describing all of these materials is cast polymer. The term is recommended so you can discuss this potential fixture and surfacing material without limiting yourself to describing a product that looks like synthetic marble.

Regardless of the use, cast polymer surfaces are created by pouring a mixture of ground minerals and polyester resin into a treated mold, where the curing process takes place at room temperature or in a curing oven.

Gel Coat Application

The process begins by spraying a gel coat onto a mold. Because most residential fixtures are sprayed by hand, the gel coat thickness ranges from 12 to 20 mil (1 mil = 1/1000th of an inch). Industry research has proven a 12-mil gel coat is the minimum acceptable thickness. A 20-mil gel coat is more durable. However, gel coats thicker than 20 mil do not add wearability. Quite the opposite—thicker gel coats that are applied unevenly lead to a common problem associated with cast polymer fixtures called crazing. Crazing is the presence of tiny fractures within the gel coat resulting from the thermal shock caused by repeated exposure of the material to alternating hot and cold water. This problem typically shows up around the drain in a lavatory if the gel coat is not thick enough, if the plumber improperly installs the fixture, if water stands in the lavatory, or if the incorrect cleaner is used.

Molding Process

The gel coat is first allowed to cure. A semiliquid material that consists of polymer resins, a catalyst to promote curing, and highly filled inorganic particulates of pulverized calcium carbonate, hydrated alumina, and, in some instances, glass bubbles is then poured into the mold.

If the cast polymer material will have a solid color, no further steps are taken. If the material will have a marbled pattern throughout, the second color is swirled into the mixture. The mixture is allowed to cure, after which it is removed from the mold, inspected, finished, boxed, and shipped. Figures 7.5, 7.6, 7.7, and 7.8 include a variety of cast polymer shower enclosures and bathtubs available.



FIGURE 7.5 Cast polymer shower enclosures are available in one-, two-, and four-piece designs. Many include a seat within the enclosure.

Courtesy of MAAX Bath Inc.



FIGURE 7.6 Cast polymer corner shower enclosures are very space efficient.
Courtesy of MAAX Bath Inc.



FIGURE 7.7 One-piece cast polymer showers are available without a curb to enhance access. The swing-up seat and grab bar make this a safe shower environment.
Courtesy of MAAX Bath Inc.



FIGURE 7.8 Cast polymer freestanding bathtubs are available in styles that accommodate deck-mounted fittings. This design feature simplifies the installation.

Courtesy of MAAX Bath Inc.

CERAMIC TILE: ALL SURFACES

Ceramic tile is a favorite surface product for many kitchen and bathroom designers. A beautifully natural material, it also offers wide design flexibility. However, without a solid understanding of the product, installation methods, and care recommendations, a profitable job and a pleased client may elude you.

Tile is composed of clays, shales, porcelain, or baked earth. These raw products are pressed or extruded into shapes and then fired in a kiln, baked in an oven, or cured in the sun. The differences among raw materials, manufacturing methods, and surface finishes make some types of tile more durable in heavy use areas than others. The firing method also affects the moisture absorption rate of different body types of tile, which is an important consideration in exterior tile installations.

Tile for any surface other than decorative vertical areas should be selected after careful investigation into its appropriateness for the planned installation. As you consider a tile for a specific installation, first refer to the manufacturer's literature for usage recommendations. Second, check the porosity of the tile. Third, check the availability of trim (curved shapes for smooth corners, edges, and coves). Fourth, think through your grout selection. Finally, make sure you have specified the recommended installation method for the tile you have selected.

Types of Tile

Decorative Tile

Within the family of glazed ceramic tile, there is a subcategory often called *decos*. These attractive accent pieces may include a raised or recessed relief pattern or feature a painted or silk-screened design. Generally, the relief designs are planned for vertical use only because the three-dimensional tiles are difficult to clean on a counter surface or floor area. Some of the hand-painted tiles may be so delicate that general countertop or floor cleaning will damage the pattern; but they are popular for walls and as inserts in backsplashes.

Some decorative tiles, as seen in Figure 7.9, create a design that flows from tile to tile to give designers great flexibility for a unique, one-of-a-kind wall, border, or backsplash. Others are one-of-a-kind art pieces that should be showcased within the field of plain tile.

In addition to relief-type deco tiles and hand-painted tiles, long, slender tiles called liners are considered decos. Metallic tiles are also often used as decorative elements. These tile pieces have different names and come in many sizes and thicknesses from different manufacturers. Designers need to become familiar with manufacturers before they can identify the specific accent tile they are considering. Figure 7.10 features a combination of materials including decorative and ceramic tile, quartz, and granite.

Glazed Tile

A coating of glass-forming minerals and ceramic stains is called the glaze. The glaze is sprayed onto the body of the tile (known as the *bisque*) before firing. The finished surface may have a shiny luster as seen in Figure 7.11. Some glazed surfaces can be slippery to certain footwear, especially when the footwear or surface is wet.

Glazed tiles are available in a variety of sizes. They may be as small as $\frac{1}{2}$ by $\frac{1}{2}$ inch mounted in 12 by 12 inch squares on a meshed backing. Typical sizes are 4 by 4 inches, 3 by 6 inches, 4 by 8 inches, 6 by 6 inches, and 12 by 12 inches. Innovations in manufacturing systems have resulted in larger, oversized tiles being available. While 18-by-18-inch and 24-by-24-inch sizes have been on the market for some time, today tiles are available in 13 by 36 inches and 17 by 27 inches, and oversized 30-by-30-inch or 36-by-36-inch squares.

Glazed tiles are also available in a variety of finishes; some have a slip-resistant glazed texture. Various thicknesses are available. Shiny, high-gloss glazed tiles may dull slightly with wear over a period of time with continued use. Black or dark-colored glazed tiles will show wear more rapidly than lighter colors. The type of glaze often determines the recommended end use of the tile (i.e., walls [Figure 7.12], floors, and counters).

Glass Tile

Decorative glass tiles—the roots of which go back to Mesopotamia more than 4,500 years ago—are a popular alternative today as manufacturers and artisans experiment with colors, materials, and techniques. One of the main attractions of glass tile is the way light reflects



FIGURE 7.9 A decorative tile is used on the backsplash in this kitchen featuring granite countertops.

Design by Pietro A. Giorgi Sr., CMKBD, and Ellen Cheever, CMKBD, ASID, CAPS. Photo by Peter Leach

FIGURE 7.10 A combination of materials is used in this entertaining center adjacent to a kitchen. Quartz countertops are combined with a stripe of the granite seen in the adjacent kitchen. The granite is framed with decorative relief tile and a pencil framing tile. Note the oversized ceramic tile patterned floor that features a design combining four different sizes of tile.

Design by Pietro A. Giorgi, Sr., CMKBD, and Ellen Cheever, CMKBD, ASID, CAPS. Photo by Peter Leach



FIGURE 7.11 Glazed tiles are used to cover the entire wall surface in this Manhattan kitchen.

Courtesy of Jenn-Air



FIGURE 7.12 A decorative stripe of tiles is installed to accent the backsplash in this kitchen.

Design by Joseph Giorgi, Jr., CKD, Pietro A. Giorgi, Sr., CMKBD, and Ellen Cheever, CMKBD, ASID, CAPS. Photo by Peter Leach

off them, drawing the eye to their sleek surfaces. Glass tiles come in textures from mirror slick to rough, and in a variety of colors from deep and muted to multicolored with iridescent options. Glass tiles are available in clear glass all the way through or with a backing finish designed to camouflage the rough wall surface.

A variety of sizes is available. Custom mosaic patterns are possible with tiles sized 1 by 1 inches, 2 by 2 inches, and 4 by 4 inches. Mosaics $\frac{1}{2}$ by $\frac{1}{2}$ to 2 by 2 inches are mounted in 12- by 12-inch sheets with a mat backing or paper overlay on the face of the tiles. This is removed after the tiles have been mounted. Individual tiles and field tiles come in basic geometric (square, rectangles, octagons) and specialty shapes.

Glass tile installations, as seen in Figure 7.13, require special expertise. Because of the translucency of many tiles, manufacturers recommend setting glass tiles in white adhesive that should be smoothed carefully to prevent notched trowel lines from showing through. Additionally, a typical tile saw will not cut glass tile: A diamond wet saw will be required for cutting. Although glass tiles are more difficult to work with, they are extremely durable because they are hard and nonporous (see Figure 7.14). Some can actually be installed in exterior environments. Because they can scratch easily, they are not recommended for kitchen counters or floors unless they are etched and embossed with a textured surface.

Glass tiles are typically manufactured in one of two ways:

- 1. Slumped or heat molded.** Sheets of glass are heated to the point where they soften and sink into molds that give the glass distinctive three-dimensional patterning or texture. Color can be added to the mix or fused to the back in this manufacturing process.
- 2. Cast or poured.** The oldest method of making tiles is to pour molten glass into forms. Glass can be colored by adding pigments or oxides or pieces of different-colored glass into the mix. Once again, fusing colorful glass to the back of the tile can add to the depth and make the finish opaque.

For a discussion of limestone tile, See “Stone—Limestone,” page 278; For a discussion of marble tile, see “Stone—Marble,” page 279. Marble is a material used in both kitchens (see Figure 7.15) and bathrooms.



FIGURE 7.13 Glass tiles are used in the shower enclosure area of this Contemporary bathroom.
Design by Ellen Cheever, CMKBD, ASID, CAPS. Photo by Peter Leach

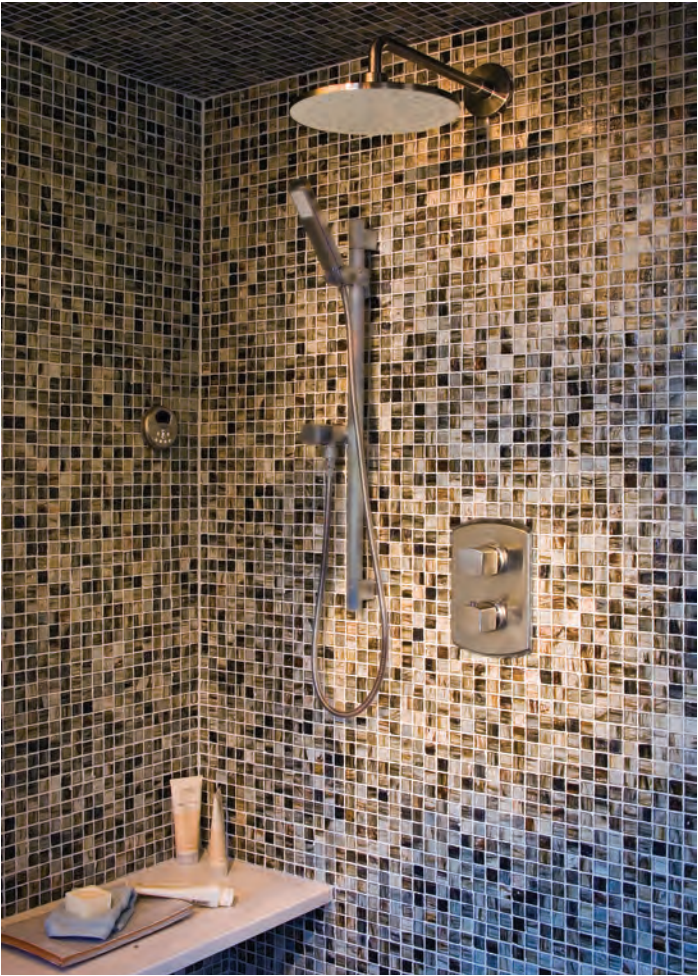

A close-up view of the glass tile in the shower area.



FIGURE 7.14 Glass tile is combined with tumbled marble tile in this backsplash treatment.
Courtesy of GE Appliances



FIGURE 7.15 A tumbled marble tile is used at the backsplash and covers the entire wall space behind the hood. A geometric pattern is created, highlighting the area beneath the hood. The kitchen countertops are granite. Note the curved detail at the raised eating area that provides more seating space.
Design by Pietro A. Giorgi, Sr., CMKBD, codesigner Nancy Conklin

Mosaic Tile

Mosaic tiles are distinguished from other kinds of tile by their small size, which must not exceed 6 square inches (2.45 by 2.45 inches if square shaped). The most common types are natural clay and porcelain in which the color is throughout the tile rather than being applied on the surface, such as a glaze. However, glazes may be applied as well. Porcelain ceramic mosaic tiles are always vitreous (natural clay) or impervious (porcelain). Therefore, they have a very low water absorption rate, less than 0.5 percent. They have a harder, denser body than nonvitreous wall tile. Glass mosaic tiles are also available.

Mosaics are usually sold face-mounted with paper, back-mounted with a mesh or plastic tab backing, or mesh-backed in 12- by 12-inch or 12- by 24-inch sheets. Mounted sheets facilitate installation and control the evenness of spacing.

When combined with the appropriate trim, the small-size units allow contour design applications in bathroom layouts. They are also very effective in kitchen backsplash designs.

Quarry Tile

Quarry tile is made from shale, clays, or earth extruded to produce an unglazed product that has color throughout the tile body. There is a great variety of quality levels within the broad term “quarry tile.” The earthen clay tiles may be very soft and irregular in shape. Other types of quarry tile are so porous they require a penetrating sealer to protect the surface. Before such a sealer is applied, the tile and grout must be allowed to cure. New sealer products have been formulated to minimize the cure time. Depending on the product used, this curing process can take as little as 48 hours or as long as two weeks.

Other so-called quarry tiles must be stained and sealed. If such extra steps in the installation process must be completed, the designer should include the extra costs incurred in the estimate.

Certain manufacturers’ quarry tiles meet the standards of the American National Standards Institute (ANSI) and are considered stain-resistant, although not stain-proof. Thus, application and renewal of a sealer is optional. To achieve the subtle patina or rich glow of natural quarry clay, seasoning the tile with oil-based cleaners (e.g., Murphy’s Oil Soap® or Lestoil®) is preferred to sealing.

Quarry tile is suitable for interior residential and commercial floors, walls, and fireplace facings. Quarry tile may be used on exterior surfaces when proper installation methods are followed.

Slate Tile

For a discussion of the use of slate tiles, see “Slate,” page 280.

Ceramic Tile Planning Tips from the Pros

Select glazed or unglazed surfaces. The glaze finish is an important criterion to consider. Tiles are available in a variety of glazes:

- Semigloss
- High gloss
- Matte
- Two-tone, or a combination of gloss and matte.

Figure 7.16 shows a decorative high-gloss glass tile backsplash in a Manhattan, New York, kitchen.

Gloss finishes can dull with heavy use. With a matte glaze, wear is not nearly as noticeable. Both tiles have the same degree of hardness. For floors, matte or unglazed porcelain are recommended.

Glazed tile, smooth to the touch, can be slip-resistant due to a special manufacturing process. Textured glazes with a noticeably rough surface are also slip-resistant. Varying degrees of slip



FIGURE 7.16 A decorative high-gloss, hand-painted glaze tile backsplash.
Design by Pietro A. Giorgi, Sr., CMKBD, codesigner Nancy Conklin

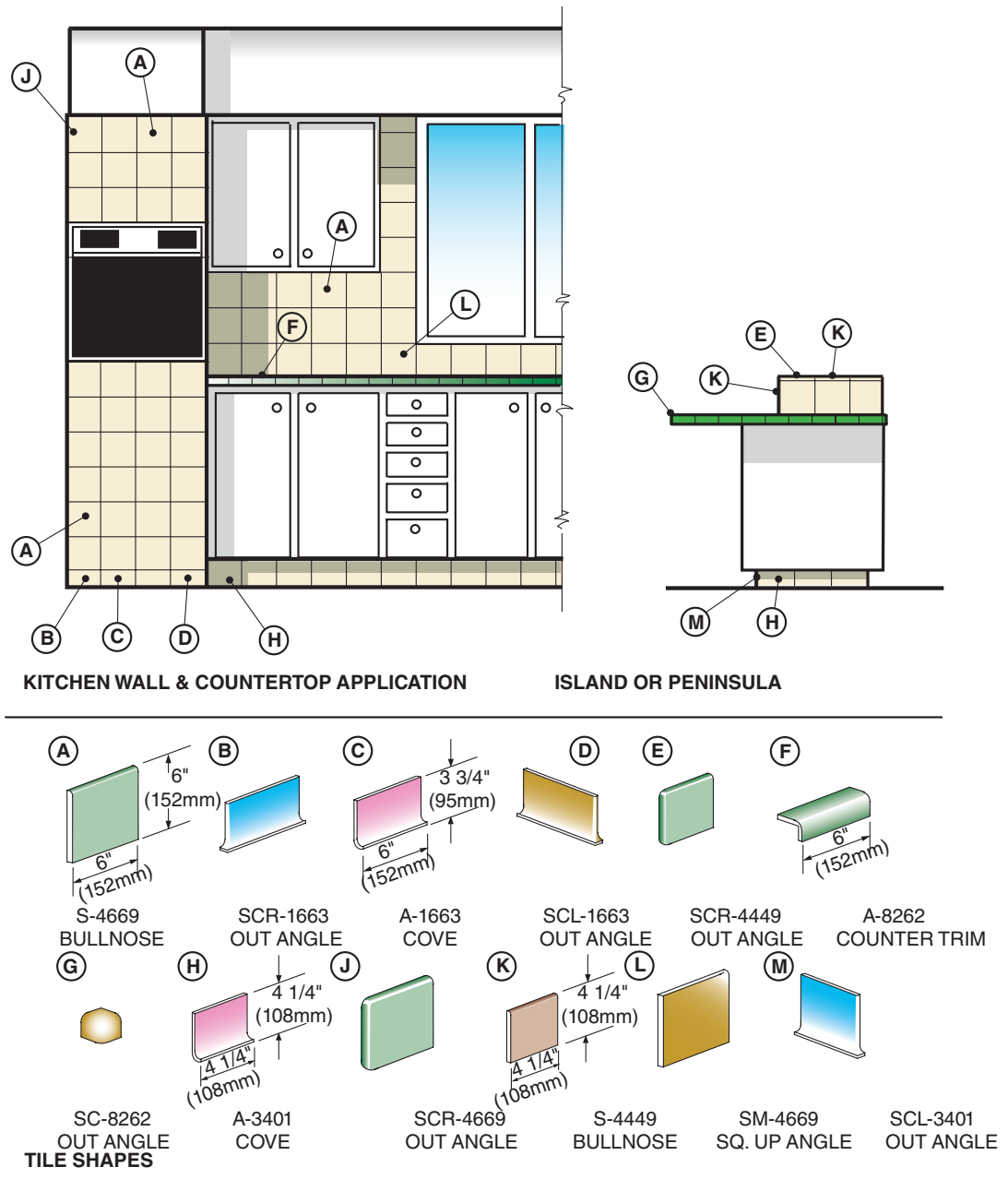

FIGURE 7.17 Shapes of tile trim

resistance are needed for a variety of end uses. Safe bathroom and kitchen designs require that slip-resistant tiles are specified for floor applications.

Select the correct surface trim. Just as important as the tile shapes is the availability of trim shapes (see Figure 7.17 and Figure 7.18). While the floor can be installed with nothing more than a plain or field tile edge (tile without any finished or shaped edge), the countertop, bathtub enclosure, shower stall, floor baseboard treatment, or vanity top calls for specially designed pieces to complete the installation.

Trim shapes are available with $\frac{3}{4}$ -inch radius for conventional mortar installations and $\frac{1}{4}$ -inch radius for organic adhesive installations. These trim shapes are generally more expensive than the square footage price of the field tile because of the cost of production. The color

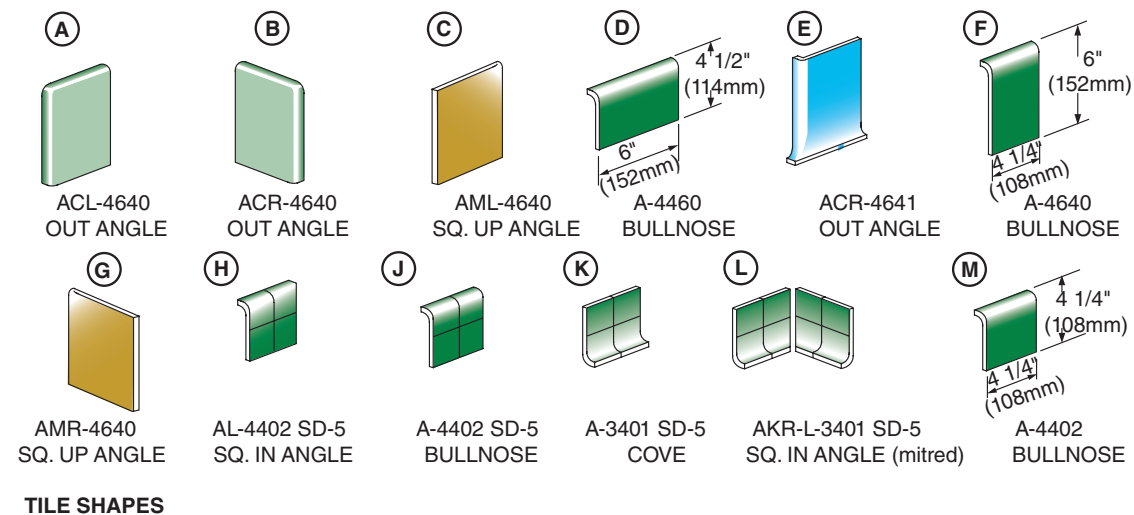
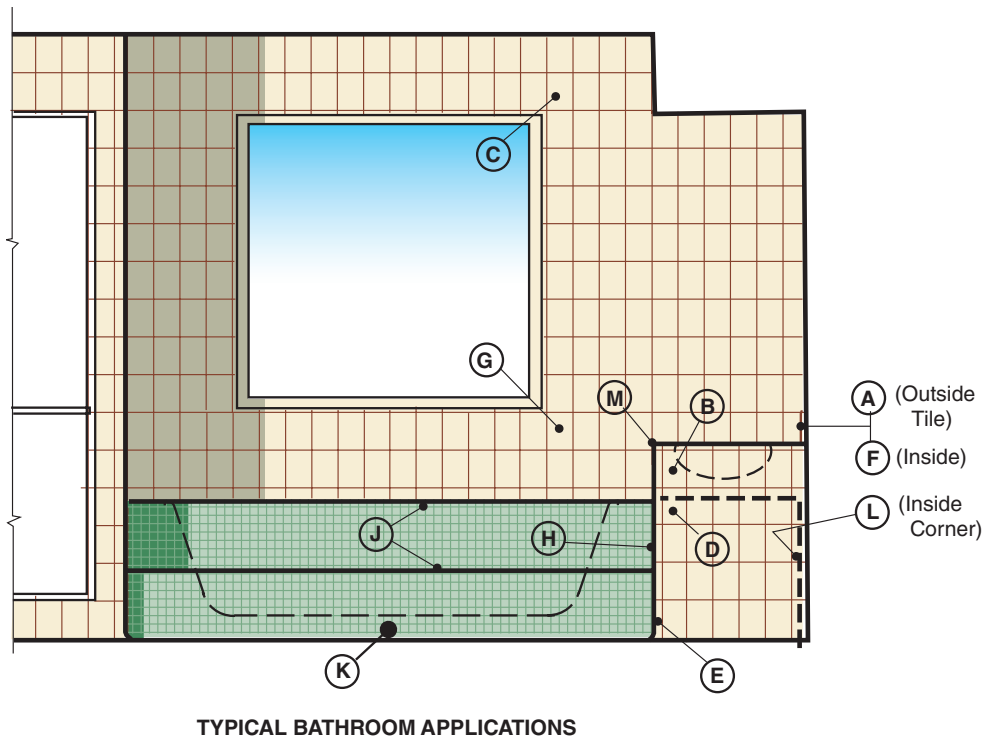

FIGURE 7.18 Shapes of tile trim

and texture match is generally good between field tile and trim shapes, but there may be a slight or pronounced texture difference in some selections. When you are using ceramic tile for the first time, visually compare a field tile and trim shapes before placing the order. If there is any variation, the client should approve the difference before the order is placed.

Combining tiles of various shapes and sizes is most successful when one manufacturer's product is selected (see Figure 7.19). Typically this assures the designer that tile thicknesses will remain constant.

In addition to ceramic tile trim pieces that match the field tile, aluminum edge trim can be used to finish an elevation.

FIGURE 7.19 Combining tiles of various shapes and sizes is most successful when one manufacturer's product is selected.

Design by Joseph Giorgi, Jr., CKD, Pietro A. Giorgi, Sr., CMKBD, and Ellen Cheever, CMKBD, ASID, CAPS. Photo by Peter Leach



When working with accent tiles, create the design and the electrical plan concurrently. Codes require a specific spacing of electrical outlets along a backsplash. Task light switching and the switch for the food waste disposal will also be located along the backsplash. The backsplash light and the backsplash design details must be coordinated with the electrical layout so outlets or switches do not interfere with the backsplash itself or decorative elements of the space between the base cabinets and the wall cabinets.

Grouts

Different types of grout are available, each designed for a particular kind of installation and/or to be used with specific tile sizes and shapes. The Tile Council of North America has excellent technical information on its Web site (www.tcnatile.com).

Following is an abbreviated overview of the Tile Council's information (materials for grouting, ceramic, and stone tiles—ANSI specifications).

- **Portland cement** is the base for most grouts and is modified to provide specific qualities, such as whiteness, mildew resistance, uniformity, hardness, flexibility, and water retentiveness.
- **Sand-Portland cement grout** is used with ceramic mosaic tiles, quarry tiles, pressed floor tiles, porcelain tiles, some glass tiles, and stone tiles on floors and walls. Because of the sanded nature of this grout, it is important to check that the sand in the grout will not scratch the surface of the tile. Sanded grout is always used for joints wider than $\frac{1}{8}$ inch.
- **Standard cement grout** (sometimes referred to as *unsanded* or *nonsanded*) is suitable for grouting walls and floors subject to ordinary use. Some glass tile manufacturers require unsanded grout to prevent scratching on the smooth glass surface. This product is meant for joints of $\frac{1}{8}$ inch or less.
- **Non-cement-based grout**, such as epoxy, furans, and silicone rubber, offers properties not possible with cement grouts. However, special skills on the part of the tile setter are required. Additionally, these materials can be appreciatively greater in cost than cement-based grouts.
- **Polymer-modified grout** is available in both sanded and unsanded, and is a factory-prepared mixture of cement and other ingredients. Grouts in this category provide improved characteristics, such as increased color stability, stain resistance, bond strength, flexural strength, and lower water absorption to resist frost damage.

Other grouts are available that have specific characteristics required for commercial installations.

Method of Installation

Three methods of installation are used for ceramic tile projects.

Conventional Mortar Bed (Mud)

In this method, the tile is installed on a bed of mortar $\frac{3}{4}$ to 2 inches thick. Two systems are popular in North America. In one, the tile is set on a mortar bed while it is still soft. In the other, tile is set on a cured mortar bed.

Mastic (Organic Adhesive)

In this method, tile is directly applied to the countertop, decking, or cement surface with troweled-on mastic. When this method is used, the finished floor will be raised only the thickness of the tile. Manufacturers state that a mastic installation may use any of these base surfaces: existing tile, fiberglass, wood paneling, brick, masonry, concrete, plywood, or vinyl. The surface must be dry, flat, and free of dirt and grease.

The tile installation cannot camouflage any existing structural problems. If there is a bow in the floor before the tile is installed, it will be there after the tile is installed.

Thinset over Backerboard

A glass mesh concrete backerboard may take the place of a conventional mortar bed. It is unaffected by moisture and has one of the lowest coefficients of expansion of all building panels. Additionally, the boards are only one-half the weight of conventional mortar installations. In non-wet areas, exterior grade plywood can be substituted for backerboard.

Special Considerations

In either conventional mortar (mud) or thinset over backerboard installations, the floor or vanity height will be raised the thickness of the tile and the mortar bed or glass mesh concrete backerboard. This height difference may require special floor preparation. In new construction, the subfloor can be recessed to accommodate a tile floor. In renovation projects, a transition method between the new higher tile floor and adjoining floors must be specified. Special toe-kick heights must be detailed so the industry standard of 4-inch-high kick space is maintained.

Most tile setters recommend the mortar installation be used over wood subfloors. The advantage to this type of installation is that the tile (installed with a cleavage membrane) will float on top of the wood. Normal wood expansion and contraction will not cause cracks in tile or grout. The mortar installation is also more desirable when there is heavy traffic. Figures 7.20, 7.21, and 7.22 illustrate important installation details.

Floor Tips from the Pros

In renovation jobs, removing the existing floor covering is recommended. Generally, this is necessary if vinyl tiles or cushioned vinyl floors are installed over a slab or wood foundation. In many parts of the country, tile is installed directly over old noncushioned sheet vinyl.

Doors may require modification to accommodate a tile floor. With a mastic installation, the designer is concerned only with the thickness of the tile. When a conventional mortar installation is planned, the designer must allow clearance for a $\frac{3}{4}$ - to $1\frac{1}{4}$ -inch-thick mortar bed, plus the thickness of the tile. A glass mesh concrete board installation will require a clearance dimension equal to the thickness of the board plus the tile (see Figure 7.23).

Allow enough time for the door modification. Interior hollow-core or solid-core doors are easy to cut down. Pocket doors must be the type that can be removed from the pocket.

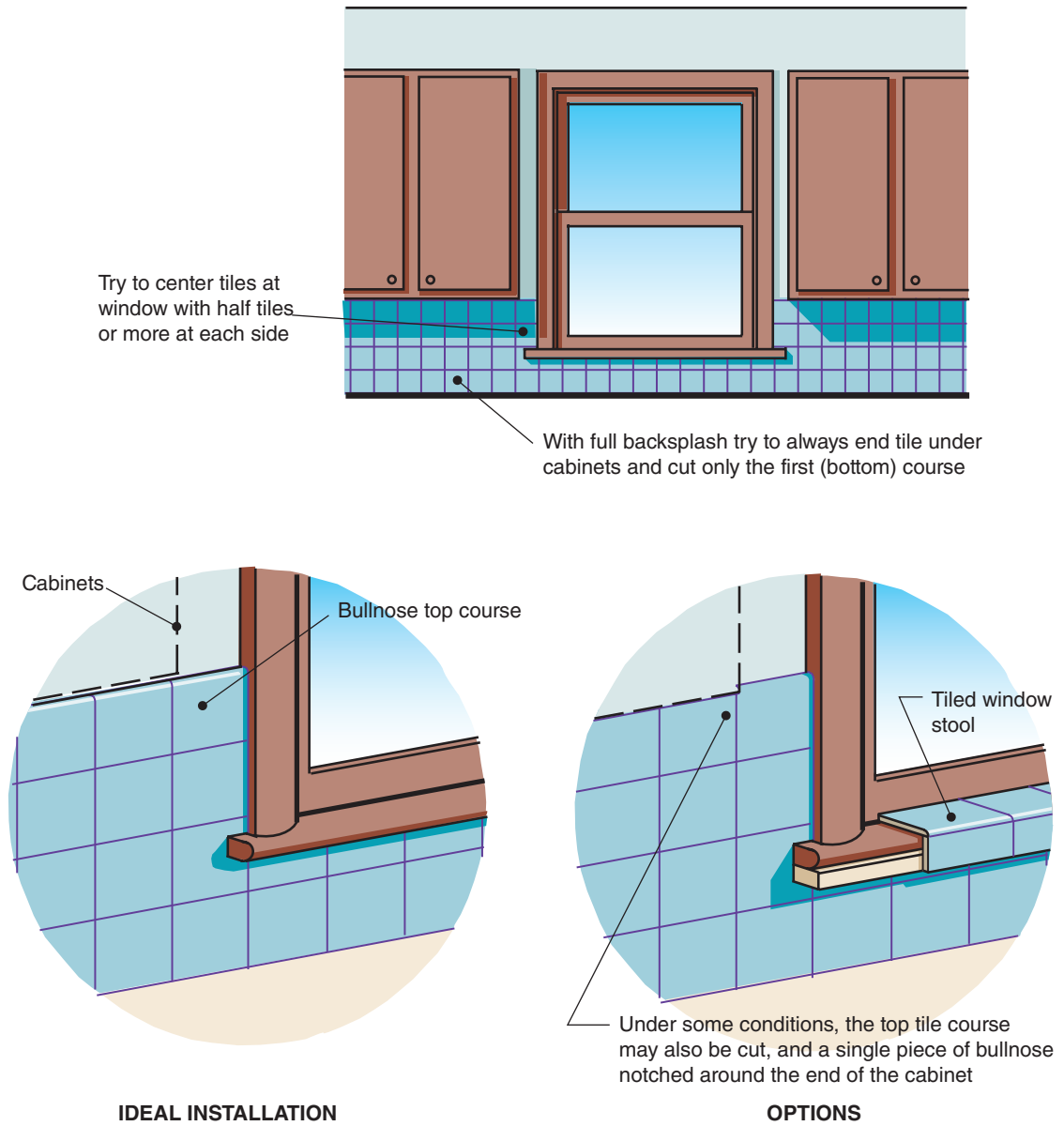

FIGURE 7.20 Tile details: Detail how you want the tile to be finished around the windows in your elevation drawing.

If the new tile floor will be higher than the finished flooring of an adjacent room, **the tile selected must have trim pieces or a threshold must be planned** (see Figure 7.24). Thresholds are generally marble or wood. Solid surface material can also be used as a threshold.

When doing a mortar base tile installation in a kitchen renovation project, it is recommended that you tile the floor before the cabinets are installed to maintain the proper cabinet height and 4-inch toe kick. You can also run into a problem with locking in your appliances.

Make sure the distance from the finished tile floor to the underside of the kitchen countertop leaves enough room for a built-in dishwasher, and extend the flooring under the dishwasher.

Make sure a tile backerboard does not interfere with the toilet supply line escutcheon plate.

When planning an accent pattern on floors, as seen in Figure 7.25, the details must be laid out during the planning phase to ensure proper fit and finish.

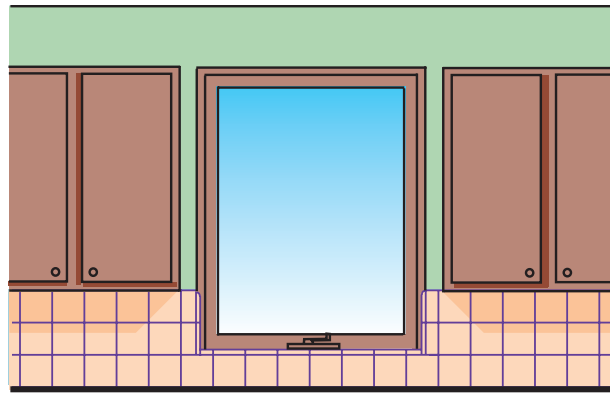

When tiling a window return, try to conform the width to the tile modular dimension

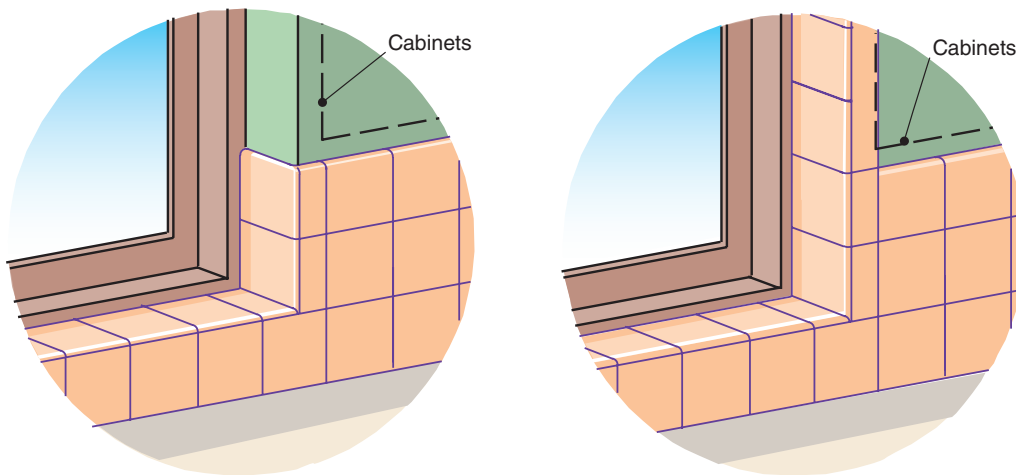

Under some conditions, tile returns may continue up and around window

FIGURE 7.21 Tile at windows with Sheetrock returns: Include details of finished windows in your elevations.

Bathroom Wall Tips from the Pros

Run the tile to the floor. When planning a tile enclosure around a bathtub, make sure the tile extends past the bathtub and runs down to the floor. This extra tile width will protect the drywall surface underneath from moisture damage over years of use.

Coordinate wainscot height with vanity backsplash. When planning a tile wainscot in a bathroom, specify the height so it has some relationship with the vanity and its backsplash. You may eliminate the backsplash completely and run the trim or molding at the top of the wainscoting in place of a backsplash. Alternatively, you can step the wainscoting up so it ties in at the same elevation as the backsplash.

Tile a small wall next to the toilet. When planning a 36-inch-high tiled privacy wall that shields the toilet area from view, plan to tile the entire wall if the floor in the room is also tiled. This small wall section can be quite awkward if it has a tile baseboard at the bottom of it and a tile cap at the top but no tile in between.

Determine finished wall dimensions. If you are going to be tiling the wall area around the toilet, make sure you take the added dimension of the installation method and tile thickness into account when you determine finished wall dimensions. For example, if you are going to tile three walls around a toilet with a conventional mortar installation, you need to maintain

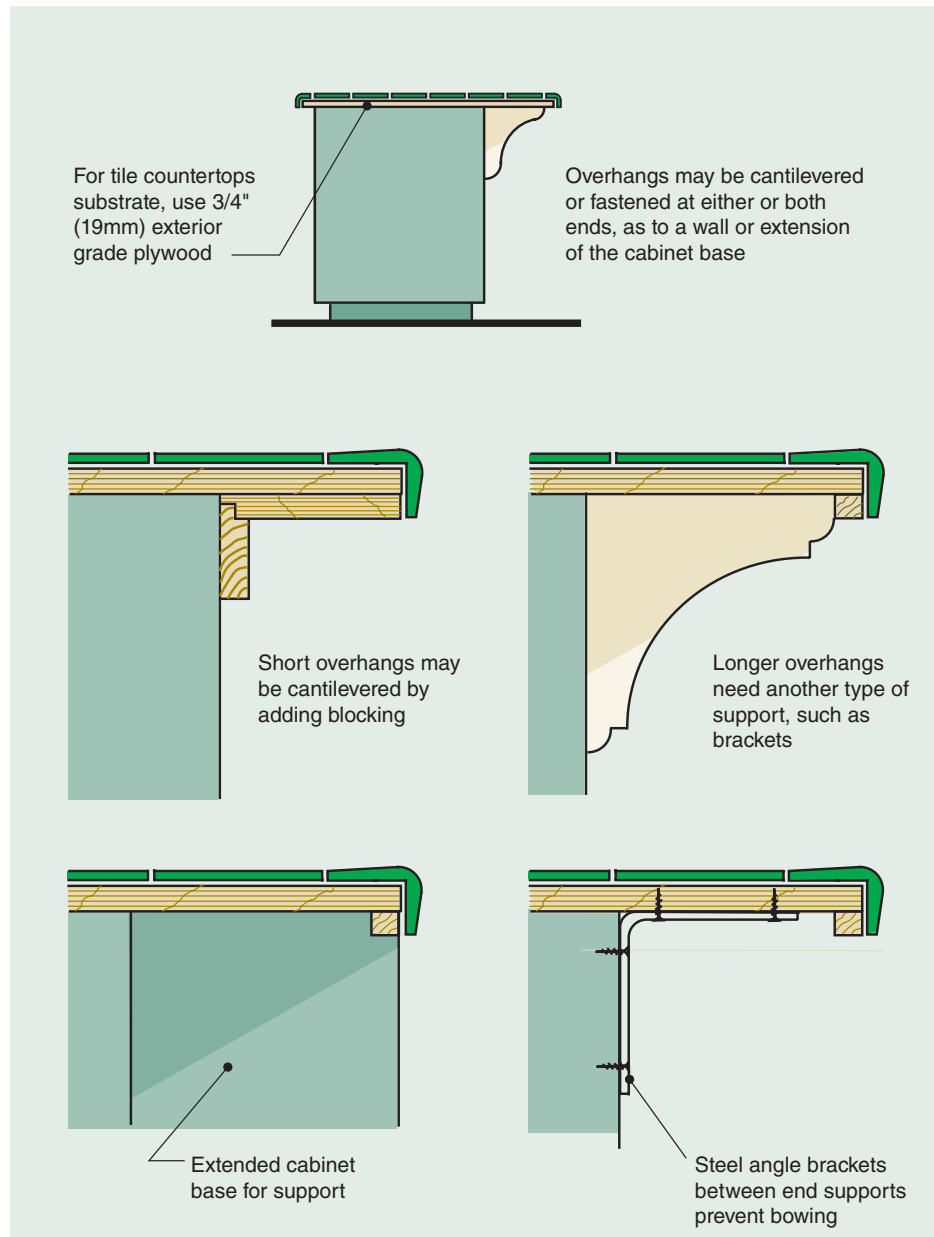
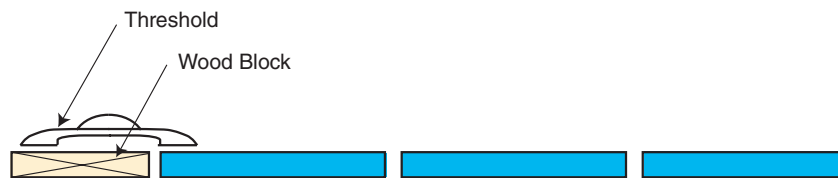

FIGURE 7.22 Surfacing materials: Support tile overhangs: The tile overhang must be supported so the surface does not flex, causing tile or grout to crack.



PREFERRED INSTALLATION



LESS ACCEPTABLE INSTALLATION

FIGURE 7.23 A tile floor must be carefully planned so it meets the threshold or weatherstripping at an exterior door.

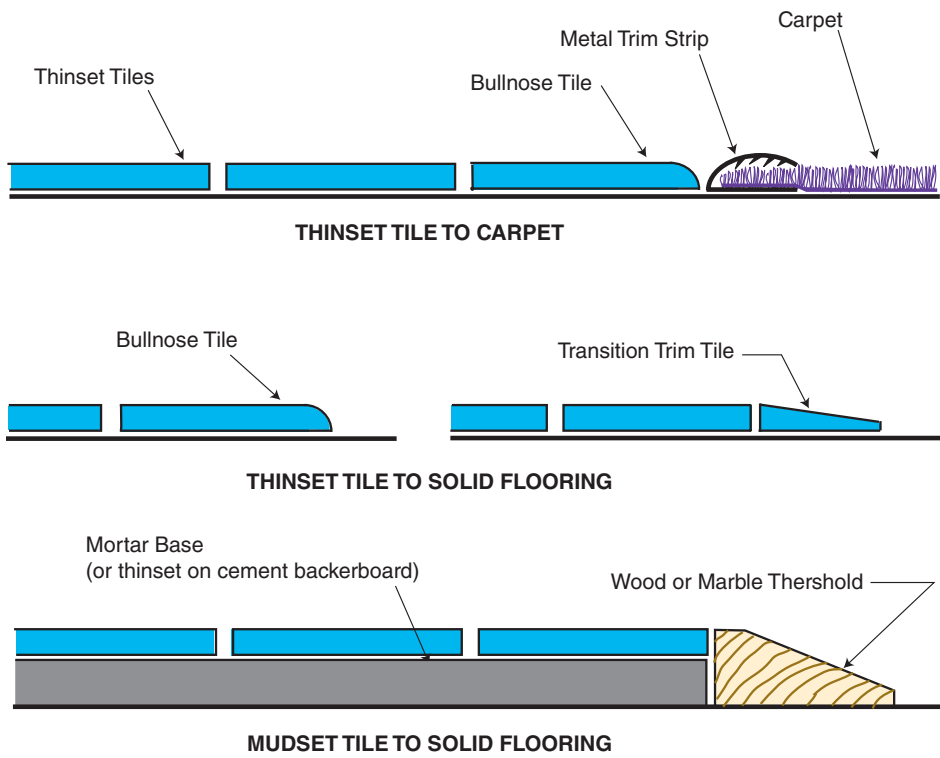

FIGURE 7.24 Transition methods from a tile floor to other interior floor surfaces



FIGURE 7.25 Bathroom that features an accent pattern on the floor and in the shower
 Design by Pietro A. Giorgi, Sr., CMKBD and Ellen Cheever, CMKBD, ASID, CAPS

FIGURE 7.25 (Continued)



a minimum clearance between your drywall of 33 to 35 inches to make sure the job meets the code requirement of 30 inches between the finished side walls. Another typical error occurs when a tile wainscoting finish is applied to the wall behind the toilet, which then reduces the actual finished floor distance from the wall to the toilet's floor outlet. That 12-inch rough-in dimension must be from the center of the floor outlet to the finished surface on the wall, not the drywall behind the tile.

Plan the grout lines. If you are planning to tile all four walls in a room, plus the ceiling, decide where it is most important to have grout lines on the wall line up with the grout lines on the ceiling. Generally, as you stand at the doorway, the wall at the far end of the room, or the most important wall, will be the focal point. Therefore, this wall should be where the tile setters start running the tile up the wall and then across the ceiling. If the room is square, the grout lines will run down the wall on the opposite side. However, in renovation situations, this rarely occurs.

Specify the accessory placement. If you are tiling a wall surface, remember to decide where you are going to install the accessories (the toilet paper holder, towel bars, and robe hooks), and make sure you determine how you are going to install the accessories on the new tile surface.

Determine the overlap ratio in running bond tile installations. A *running bond* pattern can be created in one of two ways:

1. Tiles are laid end to end, with joints that land in the middle of the tiles in adjacent rows. This pattern is appropriate for smaller-size tiles.
2. Tiles are laid end to end, with joints that land at a one-third or two-thirds point in each adjacent row. This is appropriate for larger tiles because of the natural camber bow that will occur in the manufacturing process of large tiles. While large tiles are perfectly square, they will not be perfectly flat. They are flat at each end with a slight bow in the center; therefore, the running bond pattern should intersect the tile by one-third, not by one-half.

CONCRETE

Concrete is a specialized countertop surfacing material (see Figure 7.26). Molded into shape, it is seamless. Concrete can be dyed just about any color. Concrete countertops can be fabricated at the manufacturing facility or poured in place. Because it begins in the form of a



FIGURE 7.26 A kitchen with a concrete countertop. Concrete is used along the oversized backwall counter surface, as well as a support for the island.

Courtesy of Fu-Tung Cheng, Cheng Design. Photo by Mathew Millman Photography

slurry, concrete can be transformed into virtually any shape that becomes a solid mass. It can be polished, stamped, or stained. Objects can be embedded in it.

While it has a rougher appearance than granite or solid surfacing, with hairline cracks (called crazing) and surface imperfections, these qualities make it appealing to many. Like granite and other natural stone materials, upkeep is minimal, but it must be sealed to prevent stains.

Initially considered an artisan's product, concrete countertops are widely available throughout North America today. An excellent resource for information about custom concrete countertops is *Concrete Countertops: Design, Form and Finishes for the New Kitchen and Bath* by Fu-Tung Cheng with Eric Olsen (Taunton Press, 2002) as well as the Web site www.concreteexchange.com.

CORK FLOORING

Cork comes from the bark of special oak trees primarily grown in Spain and Portugal. The wood product comes from a renewable process where 6 to 9 inches of bark is cut from the trunk. It takes five to seven years to grow back after harvesting.

Cork is a soft-hard surface. It is soft, warm, and quiet. It also may be helpful to homeowners with allergies. A variety of patterns is available, which are achieved by different peeling techniques: Some look like a cork stopper, some like a bulletin board or burl wood. The most popular finish is natural—similar to natural oak (see Figure 7.27). Cork is also available in different stains, including brown, deep reds, and a white washed tint.



FIGURE 7.27 Cork flooring
Design by Joseph Giorgi, Jr., CKD

Quality levels do vary in cork products—the thicker the top veneer, the more cushioning and the better wear and performance. Therefore, price varies on the density and thickness of the cork veneer as well as the padding underlayment. The number of urethane coats on the veneer (between two to five) determines the wear.

Similar to laminate, floating floor planks snap together and can be installed over concrete or wood. Cork can be installed anywhere wood flooring can be placed; however, most experts caution against using it in high-moisture areas, such as bathrooms.

GLASS SURFACES

Glass Block

Glass block is enjoying rekindled interest among designers. Popular in the 1930s and 1940s, the use of glass block came to a standstill in the 1970s. These translucent hollow blocks of glass are ideal for kitchen and bathroom use. They transmit light yet provide privacy. When used in exterior wall installations, they deaden outside noise and offer insulating qualities similar to thermal-pane windows. Available in a variety of shapes, sizes, textures, and colors, glass block offers great design flexibility.

However, installation is not easy and should not be attempted by anyone other than a skilled mason. The blocks are nonporous, slick, and heavy, and require a footing because of their weight. During installation, they are slippery and difficult to align.

Alternatives to glass block are decorative glass-looking products that are made out of plastic materials. These substitutes are very strong and lightweight, and do not need a footing. Assembly is generally quicker with these types of acrylic and proprietary polymer blocks because they have an engineered inner locking system that fastens them together. Therefore, traditional mortar joints are not required. Some manufacturers have available a pre-formed, weather-resistant sealant that looks like a mortar joint to complete the finished product.

Glass Surfaces for Countertops or Backsplashes

At first glance, designers might consider a glass countertop only for the most dramatic of areas. Manufacturers of glass countertops present the surface as a maintenance-free, nonporous, hygienic countertop appropriate for actively used kitchens. The glass countertop manufacturing process will affect its heat resistance and durability against cracking from thermal shock if it is exposed to extreme temperature changes in a short time.

Recycled Glass

Several manufacturers offer counter surfacing materials manufactured with tempered glass, post-consumer recycled glass, and semiprecious man-made stones (see Figures 7.28, 7.29, and 7.30). Some companies make counter surfaces out of recycled glass bottles. These tops are very specialized and warrant careful review of the source manufacturing information as well as job site preparation guidelines and installation recommendations.

Tempered Glass

Tempered glass countertops come in a variety of textured finishes and thicknesses, ranging from 1½ to 4 inches. Colors and patterns can be included in the glass. Edge treatments can be polished, brushed, or textured. If the glass top is clear, a finished substrate must be below it. Wood, aluminum, or stainless steel can be used. Glass tops can also be back-painted, as seen in Figure 7.31, as well as accented with LED lighting.



FIGURE 7.28 A countertop made with recycled glass
Courtesy of IceStone®, LLC



FIGURE 7.29 Added pigments provide a variety of color options.
Courtesy of IceStone®, LLC



FIGURE 7.30 Another example of a countertop made with recycled glass
Courtesy of IceStone®, LLC



FIGURE 7.31 A kitchen combines a stainless steel countertop, a quartz island top, and a back-painted glass backsplash in the cooking area.
Design by Martha Kerr, CMKBD

HARDWOOD FLOORING

Throughout the house, wood floors are in great demand today, and wood is a viable flooring material for kitchen and bathroom projects. Hardwoods, renewable woods such as bamboo, and laminated wood floors are all possible choices.

Natural Wood Floors

Woods used for floors are mostly cold-weather hardwoods. The slow growth in cold temperatures provides the most durable wood possible. Pine flooring is the exception; it is a softwood that is sometimes used for flooring.

Oak is the most popular wood flooring in residential use because of its beautiful grain and durability. Walnut and cherry flooring also are often specified. Antique reclaimed pine, oak, hickory, and cherry woods are available for rustic interiors.

Awaiting the homeowner seeking broader horizons are exotic woods in either manufactured or custom floors, starting at roughly twice the price of oak. These woods range from the unusually beautiful rosewood to the exceptionally rugged ironwood, to pecan, teak, and the darkest ebony.

Wood floors are graded according to standards that measure color, grain, and imperfections. Clear or Select grades are generally specified for a formal look and for lighter finishes. Select and #1 Common grade are used for traditional and light-to-medium stained floors. For rustic and specialty areas, specify #2 Common, which features wide color variations and character marks like knots, streaks, and worm holes.

Laminated Wood Flooring

Prefinished laminated hardwood-looking floors are very functional for a kitchen or bathroom application. Available in tile and plank patterns, the durable laminated finish wears well in a high-traffic or high-use area. In the past, these floors were often very noisy. Manufacturers have gone to great lengths to sound-deaden the surfaces of these floors.

Laminate wood floors are available in highly textured finishes to echo the rustic nature of reclaimed floors. Laminate flooring is detailed under “Laminates” in this chapter.

Renewable Bamboo Flooring

Bamboo is a renewable grass product. The product used to make floors is up to 12 inches in diameter and 30 feet high. After harvesting, a 4-foot stump remains, which regenerates in five years.

The product comes in tongue-and-groove boards that can be glued or nailed. While comparable in price to $\frac{3}{4}$ -inch solid wood flooring, it is 30 percent harder than oak. The natural color of bamboo is light, resembling maple, and offers a clean, contemporary look. It is also available in a darker brown finish as well. Darker woods, because the color goes all the way through, can be sanded and refinished.

Bamboo can be installed anywhere an engineered wood product can be used, provided there is not too much moisture from the slab. A key ingredient to a successful bamboo installation is acclimation: The product should be delivered at least 48 hours before installation and allowed to sit in the environment where it will be installed, adjusting to the humidity level in the room so it will not shift after installation. This means bamboo floors should be installed only in conditioned spaces—not before the heating/air conditioning is turned on.

Floor Styles

There are several styles of flooring currently in use.

Parquet Flooring

Simulated 12- by 12-inch tiles or actual individual pieces of wood, parquet flooring is interlocking and blind-nailed. Parquet is sold by square footage. Allow for waste and cutting.

Plank Flooring

Plank flooring is interlocking flooring that is blind-nailed. Generally, random lengths of 9 to 96 inches are used as well as random widths. The width combinations are:

- 3 and 4 inches
- 3, 4, and 6 inches
- 3, 5, and 7 inches
- 4, 6, and 8 inches

Plank flooring is generally sold in bundles. In this case, random lengths and widths cannot be varied. Allow for waste and cutting.

Strip Flooring

Strip flooring is butt flooring that is top-nailed. All boards are the same width (2 inches and $2\frac{1}{4}$ inches) and random lengths. Both plank and strip flooring are sold by board feet. Provide allowance for waste and cutting.

Finishing

To job site finish or to spec prefinish—to wax or not—the great debate between finishing techniques and materials rages on.

Finish for Dye-Stained or Natural Floors

Tung oil and wax are nearly forgotten but are beautiful ways to protect new or resurfaced floors. The surface can be renewed indefinitely by waxing as required. Two coats of name-brand polyurethane is a great way to protect floors too, but eventually it will wear and need to be recoated. This requires resanding since cured urethanes are so hard that a new coat does not adhere well to the old one. Patching worn areas that had been protected by polyurethane is rarely successful.

Wax Maintenance

Waxing the surface remains a time-honored finishing option. Many people think maintaining the finish requires that they continually be on their knees with a polishing rag. Actually, a waxed floor might need rewaxing only once a year—and it can be done with a small buffing machine that homeowners can buy or rent. New finishing innovations offer the consumer a waxed finish that eliminates rewaxing. It is really a choice between periodic maintenance or sanding and recoating your floors with polyurethane every five or six years. Penetrating oil and wax is the way it was done for years. Its soft look is incomparable.

Whitewash Flooring

The white-gray stain of whitewash is called a pigmented stain. It creates color by causing finely ground particles to adhere to the floor's surface. Unlike a dye-based stain that penetrates the wood, a pigmented stain floats mostly on the floor's surface like paint. The particles and resins of the pigmented stain limit penetration by tung oil and hence make good adhesion difficult. Tung oil or polyurethane also would give whitewashed floors an amber tone. A clear, nonyellowing varnish with an alcohol, toluene, or aliphatic-resin base is best; they are available through suppliers to professional floor finishers.

Prefinished Wood Floors

Modern prefinished floors have a durable penetrating sealer finish applied at the factory. It is a lovely finish that increases in beauty as one walks on it; if it is waxed, there are three major disadvantages.

1. The wax will be affected by water. The factory finish will not accept an additional protective coat of urethane. The installer must completely sand the floor, remove the factory finish, and start from scratch if the water-resistant properties of a urethane are required.
2. The prefinished floor does not allow the installer the opportunity to sand the entire surface after installation to insure a perfectly even surface.
3. The prefinished tiles or planks do not provide a completely sealed top surface. Therefore, moisture from kitchen or bathroom spills can get down between and under the wood floor.

Unfinished Wood Floors

Another approach in a kitchen or bathroom is to install an unfinished floor. A urethane finish that is impervious to stains and moisture can then be installed after the unfinished wood has been sanded smooth. The multiple coats of urethane provide a sealed top surface for a kitchen or bathroom environment.

Once finished, the floors should be inspected from a standing position. Flooring is not furniture; a finish similar to the one on a grand piano should not be expected. However, small particles of debris in the finish, a wavy look or feel along the strips, deep swirls or sander marks, and splotchy areas are indications of inadequate finishing or cleaning. A quality finish may include some of these problems, but they should not appear over the entire floor.

Hardwood floors come in either random-width or single-width (see Figure 7.32) planks. They can be combined with other flooring surfaces, such as tile, as seen in Figure 7.33. Hardwood floor planks can be installed vertically, horizontally, or on the diagonal, as seen in Figure 7.34.

LAMINATES

Laminate surfaces are found on countertops as well as cabinet interiors and exteriors, bathroom wall areas, and bathtub platforms. The following information describes the different types of laminates available.



FIGURE 7.32 This example demonstrates the design continuity of a single-width hardwood plank floor.

Design by Joseph Giorgi, Jr., CKD, codesigners Erin Paige Pitts and Dru Hinterleiter. Photo by Peter Leach



FIGURE 7.33 In this kitchen, the hardwood floor is reserved for the working center and is then connected with a tile surface at the end.

Design by Chris Novak Berry, codesigner Emily Castle. Photo by Alise O'Brien Photography



FIGURE 7.34 A wood floor installed on the diagonal and finished with a natural top coating provides an attractive contrast to the dark wood cabinetry.

Courtesy of Quality Custom Cabinetry Inc.

Laminate Flooring

Laminate flooring is available that simulates hardwood flooring. It consists of several layers of material bonded together under high pressure, similar to the laminate products used for countertops. A clear melamine top layer protects the design layer. Then follows a plastic resin-impregnated paper layer with wood grain pattern printed on. These are bonded to a structural fiberboard core, backed by a layer of melamine. The clear topmost wear layer is smooth and can be slippery when wet, making laminate flooring a questionable option for baths.

Installing laminate flooring entails applying glue to the tongue-and-groove edges of each piece and pressing it into the abutting piece on the floor, without actually attaching it to the floor. The finish floor then “floats” above the substrate. There are currently two choices of underlayments, a $\frac{1}{4}$ -inch-thick, low-density fiber panel, 24 by 30 inches, or closed-cell foam cushion, which is shipped in rolls. Laminate flooring installs over concrete slab floors in much the same way as over wood-framed floors, except that a poly vapor barrier is placed over the slab before the underlayment material.

Composite Panels

A composite panel is composed of a layer of decorative paper impregnated with either melamine resin or polyester resin that is thermal set or thermal fused (fused with heat and pressure) to a substrate of particleboard, fiberboard, or some other material. It is sold as laminate board. This differs from high-pressure laminate, which is sold in sheets to fabricators who apply it to boards themselves. It is sometimes known as thermally fused melamine, low-pressure laminate, short-cycle laminate, melamine, or MCP.

Composite panels generally have just one print sheet on the surface, although some suppliers offer an overlay sheet. Both front and back of the panels are laminated to avoid warping. Generally, these panels are offered in a limited range of colors and patterns.

Composite panels are used in vertical or light-use horizontal applications, such as shelving. They should not be used for countertops.

Generally, the layer of decorative paper is thermal-fused to the substrate; therefore, there is a stronger bond than high-pressure laminate, paper, or other surfaces, which are mechanically

fused to their substrate. The decorative paper will not delaminate because it becomes part of the substrate surface .

Composite panels have a lower weight than high-pressure laminates and offer some cost savings. However, composite panels typically offer less impact and abrasion resistance than high-pressure laminates.

High-Pressure Decorative Laminates

High-pressure decorative laminates typically are composed of three types of paper fused under heat and pressure into a single surface. The top coat is a melamine resin-saturated overlay. The second sheet is the decorative paper, consisting of a melamine resin-saturated paper carrying either a surface color or a gravure print. Under these two levels is a core or body made up of three to nine sheets of phenolic resin-saturated Kraft paper.

The entire assembly is pressed at between 1,000 to 1,200 pounds (454 kg– 544.8 kg) per square inch for about one hour at temperatures exceeding 280° F (137.78° C).

High-pressure decorative laminates are divided into forming and nonforming grades. Non-forming laminate is rigid, while forming laminate has been engineered to be more flexible so it can be bent under heat. This process is called *post-forming*.

The cabinet industry uses vertical-grade high-pressure decorative laminate that is 0.030 inch thick and may be formable. Countertop fabricators use a horizontal grade of high-pressure decorative laminate that is .050 inch thick and is typically not formable. The post-forming countertop grade is .042 inch thick.

High-pressure decorative laminates are used most frequently on countertop surfaces (see Figure 7.35). They are also used by many cabinet manufacturers for door styles. High-pressure decorative laminates are generally applied to a particleboard substrate. *Green* manufacturing processes now produce environmentally friendly substrates.

Of all the laminates available, high-pressure decorative laminates offer the greatest impact resistance. They are available in a wide range of colors, patterns, textures, and finishes, as seen in Figure 7.36 and Figure 7.37. Improved printing methods have created realistic



FIGURE 7.35 Laminate countertops have been engineered to allow for a flush sink installation.

Courtesy of Wilsonart



FIGURE 7.36 High-pressure laminate surfaces are available in high-definition pattern finishes featuring edge treatments that eliminate a black line between edge and surface.

Courtesy of Wilsonart

stonelike patterns in laminate products. These surfaces can be textured to make their visual appearance even closer to natural stone. Some manufacturers offer special fire-resistant, abrasion-resistant, and chemical-resistant surfaces.

Generally, all high-pressure decorative laminates have excellent stain, abrasion, scuff, and wear resistance. However, because the laminate is applied on a substrate, if a chip occurs, it is not repairable. Smooth glossy finishes show scratches more easily than matte and textured. Solid colors typically show scratches more readily than pattern surfaces.



FIGURE 7.37 High-pressure laminates offer realistic natural wood and stone patterns and are available in a textured finish that further replicates the natural product's beauty.

Courtesy of Formica Corporation

PAINT

Painting is one of the finishing steps in a kitchen or bathroom project. Often the designer is not responsible for this activity but is expected to understand the craft and make recommendations to the client. Therefore, a basic understanding of paints will aid the designer.

Paint Coverage

Paint is designed to bond itself to either a fresh, new surface or an old, uneven one. It should cover and help to protect the surface against the assaults of weather, airborne chemicals, and dirt. It should remain flexible enough to stay intact for years while the walls settle, vibrate, expand, and contract.

Paint Gloss Choices

The two major types of finishing coats—latex and alkyd paints—are available in different finish textures and sheen options. They are labeled eggshell, flat, semigloss/satin and high gloss.

- **Eggshell** denotes a sheen that has a simulated textured finish. This is a very good choice if the wall surface is not perfectly smooth.
- **Flat paints** provide a desirable low-glare surface for walls and ceilings that do not need frequent washing.
- **Semigloss or satin paints** afford moderate durability with a less obtrusive shine for most woodwork.
- **High-gloss paints** are the most wear-resistant and moisture-resistant because of their relatively high proportion of resin. The more resin, the heavier and tougher the film. The high-resin film of the glossy paints makes them ideal for areas subject to heavy use and frequent washing. However, the high sheen also makes any wall surface or finish imperfections very noticeable.

Paint Classification

Alkyd Paint

Alkyd paint has replaced oil-based paints in most cases. It is considered the best type of paint to use in rooms that will receive a great deal of use. Any painted or wallpapered surface or bare wood can be covered with paint made from a synthetic resin called alkyd (often combined with other resins). This type of paint will adhere to bare masonry or plaster but should not be used on bare wallboard because it will raise a nap on the wallboard's paper covering.

Alkyd is the most durable of the common finishing paints. Most alkyds are sufficiently dry for a second coat in four to six hours. Although some latex paints will not bond well to alkyd, most other paints can be applied over it.

Latex Paint

Latex paint provides simplified cleanup, is practically odor-free, and is quick drying. Water is the solvent for latex paint, which is made of plastic resin and either acrylics or tough polyvinyl. Its water solvency gives latex advantages that have made it the most widely used paint for walls and ceilings in living areas, other than kitchens and bathrooms. Tools, spills, and hands can be cleaned with soap and water while the latex is wet. Latex paint is almost free of odor and harmful fumes, and a coat is usually dry in little more than an hour.

Latex adheres to most surfaces painted with flat oil or latex paint; it does not adhere to some alkyds and tends to peel away from any high-gloss finish. Latex can be used over unprimed wallboard, bare masonry, and fresh plaster patches that have set but are not quite dry.

Its water solvency imposes certain limitations on latex paint. Although it can be applied directly over wallpaper, the water in the paint may soak the paper away from the wall. If latex is applied to raw wood, the water swells the fibers and roughens the surface—a disadvantage where a smooth finish is desirable. Used on bare steel, it rusts the metal.

Flat latex is less resistant to abrasion and washing than either oil or alkyd paint, and the high-gloss latex is less shiny and less durable than comparable alkyds or oils.

Faux Finishes

Faux finishing is the fine art of creating illusions with paint. With combinations of colors, finishes, tools, and techniques, painters—or talented homeowners—create unique effects for wall and ceiling surfaces.

Faux techniques can be used to showcase a client's individuality, create dramatic focal points, bring out the strengths of a room, or beautifully hide imperfections.

Trompe l'oeil. The term “trompe l'oeil” is French and means to “fool the eye.” It is often used to describe a three-dimensional mural created on a residential flat wall surface. It typically refers to a painted scene that fools the eye into looking like something with depth and distance.

Most major paint companies have faux finish systems and tools designed with well-written instructions for their application for the do-it-yourselfer. Many talented painting professionals are master faux finishers and will provide samples of their more creative techniques, upon request, for review by the designer and client.

The basic techniques typically seen are discussed next.

Color washing. This decorative paint technique creates visual texture by layering paint colors, bringing the room to life. Sometimes referred to as a modern-day fresco technique.

Crackling. Crackling is reflective of the aging process of wood finishes as well as deterioration of porcelain finishes. Porcelain crackle glazes are very small in pattern; weathered crackle glazes have a much larger overall effect. Many crackle techniques are created with color on color and may be best reserved for accent pieces. Some cabinet manufacturers offer crackle on their cabinetry.

Distressed wood finishes. Re-creating the antique appearance of furniture, paneling, trim, and accent pieces, this rustic finish softens the look of new wood, creating a vintage finish.

Distressing effects may include physical distressing, which is created with a variety of tools and techniques to age the wood. Additionally, distressed finishes may include wear-through (wearing through the top layer of the finish to the raw wood or base coat) as well as glazing techniques. Glazing techniques typically are defined as burnished, antique, or striate.

Dragging, combing, and striate. These brushing techniques create a directional pattern with layered colors.

Sponging and rag rolling. In this process, a multicolored/layered faux finish is created by dabbing color on with a rag, roller, or sponge.

Stippling. The stippling technique transforms a flat surface into a finely grained finish, adding dimension to the wall surface.

Other special effects. Patterns, stripes, fabric reproductions, basket weaves, and metallic finishes and glazing are other special finishes possible.

QUARTZ COMPOSITE

Quartz composite captures the hard durability of stone in a man-made surfacing material. Manufacturers claim it is more resilient than granite and more stain-resistant than solid surfacing. However, the feature that is attracting designers and homeowners is the polished, elegant look that is attainable with color and pattern consistency (see Figures 7.38 and 7.39). In addition to consistency in pattern, new quartz materials have been introduced that have more movement in their pattern, reflecting granite or marble veining, as seen in Figure 7.40.

Quartz composite (also known as engineered stone) is comprised of 93 percent quartz and 7 percent polymers, pigments, and binder. Since the composites are man-made, they do not have



FIGURE 7.38 A quartz countertop is attractively combined with a mosaic-styled mesh-back tile.
Design by Kathleen Donohue, CMKBD



FIGURE 7.39 A quartz countertop in a polished finish works well with glass tiles.
Courtesy of American Standard



FIGURE 7.40 Quartz countertops work well with decorative tile backsplashes.
Courtesy of DuPont Surfaces, Design by Ellen Cheever, CMKBD, ASID, CAPS



FIGURE 7.41 A quartz countertop is combined with a second quartz color that coordinates with the raised eating area. The monolithic nature of quartz counter surfaces makes it easy to combine various patterns.

Design by Ellen Cheever, CMKBD, ASID, CAPS, and Pietro A. Giorgi, Sr., CMKBD

the variations in color and texture of granite or marble. And because they are nonporous, they do not have to be sealed. The composites also are more stain-resistant than natural stone, and resins add a flexibility that prevents chipping. The composites also have a color consistency (see Figure 7.41) that saves homeowners from having to carefully choose slabs to ensure they match.

SOLID SURFACING

Designers have a broad range of solid surface manufacturers to choose from. The designer should compare these materials against the guidelines detailed in this review of the major products to ascertain their level of quality and durability. Although the major product offerings vary in material composition and breadth of product line, following are some common features.

- All solid surfacing material is stain resistant because it is nonporous and repairable because the color runs through the material.
- All manufacturers recommend cleaning with a damp cloth or sponge and ordinary household soap or mild cleanser.
- The color-through feature of these materials means severe stains (including cigarette burns) can be removed with a Scotchbrite™ pad and cleanser. Deeper scratches can be removed with 320- to 400-grit sandpaper, steel wool, and/or a buffing pad. A certified fabricator should repair deeper scratches or damage.
- While most products have excellent resistance to household chemicals, paint removers and oven cleaners can sometimes cause damage.
- All manufacturers offer solid surfaces with a factory finish that may be sanded to a matte finish or can be buffed or polished to a high gloss. No manufacturer recommends high-gloss finish on dark colors in heavy-use areas, such as countertop surfaces.
- When properly fabricated, the seam between two pieces of all the solid surfacing materials is almost imperceptible. However, you should never promise an invisible seam.
- Solid surfacing is often associated with traditional kitchen designs, as seen in Figure 7.42, but can also be shaped into unique designs, as seen in Figure 7.43. Solid surface materials can be combined into dramatic designs, as in the kitchen pictured in Figure 7.44. It is quite fabricator sensitive, and all manufacturers stress the importance of retaining only qualified and/or certified fabricators.
- Manufacturers recommend that unsupported overhangs should not exceed 12 inches with $\frac{1}{2}$ -inch sheets and 6 inches with $\frac{3}{4}$ -inch sheets.



FIGURE 7.42 Solid surface materials are often associated with more traditional kitchens.

Design by Pietro A. Giorgi, Sr., CMKBD, and Ellen Cheever, CMKBD, ASID, CAPS



FIGURE 7.43 Solid surfacing offers the designer an opportunity to creatively combine shapes because of the unique fabrication attributes of the product.

Courtesy of DuPont Surfaces, design by Ellen Cheever, CMKBD, ASID, CAPS

METAL COUNTERTOPS

Stainless Steel

Long a mainstay of the commercial kitchen, stainless steel is increasingly finding its way into the home as a countertop material, as seen in Figure 7.45. While it is heat- and stain-proof as well as noncorrosive, its main attraction to homeowners might be that it looks great next to popular upscale stainless steel kitchen appliances and in contemporary rooms. Designers are also incorporating stainless steel into bathroom designs, as seen in Figure 7.46.

Stainless steel is susceptible to dents and scratches; since it shows fingerprints, water marks, and smudges, it needs to be cleaned frequently.



FIGURE 7.44 Solid surfacing materials can be combined dramatically because of their stable expansion and contraction properties.

Courtesy of Wood-Mode Fine Custom Cabinetry

Specialty Metals

Regional manufacturers produce pewter and copper countertops and other interesting metal surfacing. They are typically used as accent surfaces. Sourcing such products should be based on availability, installation expertise, and anticipated care requirements.

STONE

Flagstone

Flagging is a process whereby stone is split into thin slabs suitable for paving. Although generally identified as flagstone, bluestone and slate are the most common types of flagging stones used.



FIGURE 7.45 A section of the countertop features a stainless steel surface.

Courtesy of Wood-Mode Fine Custom Cabinetry



FIGURE 7.46 Stainless steel can also be used in the bathroom, as we see here in the bathtub surround.

Courtesy of Kohler Design Center

Bluestone is a rough sandstone paver, usually buff, blue, green, or gray in color. Slate is a smooth, gray, sedimentary stone. The thicker the stones, the less likely cracks will occur over the lifetime of the floor. The weight of the floor must be carefully computed when used over wood foundations.

Both bluestone and slate absorb heat rather than reflect it, and can get quite hot. Irregularly cut stones are the least expensive pre-cut patterned stone.



FIGURE 7.47 A kitchen featuring granite countertops combined with a decorative tile backsplash.

Design by Pietro A. Giorgi, CMKBD, Joseph Giorgi, Jr., CKD, and Ellen Cheever, CMKBD, ASID, CAPS. Photo by Peter Leach

Granite

Polished and honed granite countertops are a popular element of upscale kitchens and bathrooms. A natural stone countertop conveys a sense of beauty and warmth that is combined with a durable work surface that can withstand the expected high use of the new space. Figures 7.47, 7.48, 7.49, and 7.50 are examples of granite used in a variety of kitchen designs.

Granite begins as the liquid magma (hot molten stone) in the center of the earth. It is a type of stone called igneous. Due to extreme pressure within the earth and the absence of atmosphere, granite is formed very dense with no pores. Granite is really a host of ingredients including common minerals like feldspar, quartz, and mica. Feldspar is the major mineral component of granite, comprising 60 to 80 percent of the stone.

Granite is not as subject to staining as marble is because of an extremely low absorption rate. It also is less prone to scratching than marble. Its coarse grain also makes it more slip-resistant than marble.

Although granite is more appropriate than marble in a residential kitchen, it will be more serviceable if it is sealed. Many natural characteristics of the granite itself impact how porous the stone is, which determines if it should be sealed or not. However, most experts suggest initially sealing the granite when it is installed and resealing it every year or every two years.

Coloration

Granites vary widely in shade, clarity, and movement of pattern. There will be variations from slab to slab because of mineral content and veining, which adds to the character of the natural stone. Therefore, most granite selections are made at the stone yard, allowing clients to reserve their stone slabs.



FIGURE 7.48 A kitchen featuring granite countertops. The backsplash at the island is a thinner slab of the material used on the deck and eating counter.

Design by Joseph Giorgi, Jr., CKD, codesigners Erin Paige Pitts and Dru Hinterleiter. Photo by Peter Leach



FIGURE 7.49 A kitchen featuring a granite countertop that blends with the cabinet finish.

Design by Pietro A. Giorgi, Sr., CMKBD



FIGURE 7.50 Granite is used as an accent on the island top. Note how the surface is supported by wood legs to the floor.

Courtesy of Sub-Zero Wolf

Granite is available in three different finishes: a highly polished surface, which is appropriate for most countertop applications; a flamed finish, which has a rough-textured touch; and a honed finish, which provides a matte surface ideal for kitchen and bathroom floor applications.

Fabrication

Granite countertops are templated at the job site and fabricated at the yard (stone fabrication facility) before final installation at the job site. For some projects, measuring the countertop for installation can be completed when the cabinets are ordered. Working from the design layout and using newly developed measuring techniques to calculate exact dimensions, fabricators can prefabricate and deliver granite tops to the job site ready for installation.

Sizing

For most countertops, the optimum thickness is $1\frac{1}{4}$ inches. The difference in cost over more fragile $\frac{3}{4}$ -inch slabs is minimal, and the added thickness gives more strength for extensions and cutouts while reducing the risk of breakage during transport and installation. This thickness also eliminates the need for a built-up edge. For example, a $1\frac{1}{4}$ -inch granite slab can support 12 inches of overhang. Keep in mind the weight of these tops as you schedule the installation crews.

Granite slabs for countertops are available in a variety of sizes. Should more than one piece be necessary, the slabs can be matched to another in the sequence for color and grain consistency and then cut to butt squarely against each other. For this type of installation, locate seams in the most inconspicuous area possible, around cutouts or back corners.

Limestone

Limestone is popular for its earthy tones and its variety of colors and characteristics. Even more easily stained and etched than marble, limestone is not a typical kitchen countertop choice, but it does wear well enough to be used on floors, backsplash areas, and bathroom surfaces. To decrease the material's susceptibility to staining, it must be regularly sealed.

Limestone is the result of millions of years of seashells and bones of sea creatures settling as the sediment on an ocean floor. The calcium in the bones and shells combines with the carbon dioxide in the water to form calcium carbonate, which is the basic mineral structure of all limestone and marble. Less than 3 percent of the stone is the color, which are simply other natural elements present when the stone is formed. Given enough heat and pressure, limestone will crystallize, resulting in marble. Limestone that has not been crystallized will not be able to be polished and will be honed.



FIGURE 7.51 A rustic kitchen features a tiled cooking alcove and a limestone tile floor.

*Design by Pietro A. Giorgi, Sr.,
CMKBD*



Marble

Marble and limestone begin as the same material. Given enough heat and pressure, limestone will crystallize, resulting in marble. The crystal structure allows marble to take a polish that brings out the color of the other trace elements. Italian marble is world renowned. Belgium, Spain, Greece, and France are also known for their marble quarries. Many U.S. quarries also produce beautiful marble slabs.

The patterns and color of marble are more varied than those of granite, and they create a softer appearance overall. Like granite, marble fits well in either contemporary or traditional settings (see Figure 7.52). However, because marble is not as hard as granite, it is more subject to surface damage. Therefore, some experts rule out unsealed marble for use on kitchen countertops. If properly sealed, a marble surface can be used in an actively planned kitchen. It is important to note that different marbles vary in their hardness factor. Generally, the lighter the color of the marble, the more delicate it is. Others suggest using very hard marble to resist wear and honed marble to hide scratches. Unless the finish is etched, honed, or pummeled, marble is slippery when wet. Therefore, make sure your clients understand a polished marble floor will be slippery.

Coloration and Durability

Numerous minerals are present that account for the markings and color range associated with marble. Marble is available in a wide color palette. Some marbles feature fluid directional patterns; others offer a general, overall design.

The more colorful and decorative the marble, the more fragile it is. Each vein in a stone is the result of natural discoloration from water. It is like a tiny fracture that, under pressure, can lead to breakage. Marble is rated according to an A-B-C-D classification based on the fragility of the stones. A and B marbles are solid and sound. C and D marbles are the most fragile but also the most colorful and decorative.

FIGURE 7.52 Marble counter surfaces are popular in kitchens. In this example, a beautifully detailed marble backsplash is featured along the back wall, coordinating with the deck.

Courtesy of Plain & Fancy Custom Cabinetry

The grade of marble, rarity of the specific type of stone, and demand for the type of material affects pricing. Before specifying marble, advise the client about durability.

Marble is soft and porous. This means it stains easily if not initially sealed with at least two coats of a penetrating seal. In addition, it must be resealed frequently. White marble is softer and less dense than colored marble, so it is more easily stained. Dark marble shows scratches more easily.

Slate

Durable, elegant, and acid- and stain-resistant, slate has a natural cleft, a split face, and a texture similar to split-cedar shingles. New England slate is stronger than granite and marble because it is made of laminated stone. The wide range of colors includes hues that range from earth tones to reds (see Figure 7.53). With its satiny, nonshiny surface, a slate countertop would blend well with matte finish cabinets in Shaker- and Victorian-style houses, where high-gloss granite might be overwhelming. But beware: Tables and chairs may rock on the irregular cleft face of a slate floor.

Slate is a metamorphic rock formed from the low-grade metamorphism of the sedimentary rock shale. Slate, like shale (mudstone), is a very fine-grained rock of mostly microscopic quartz and calcite. Slate can also contain some of the same minerals found in granite, which makes some slate iridescent and/or hard. The alteration of shale by heat and pressure produces the pronounced partings that give slate its layered characteristics. Like limestone and marble, the colors come from trace metals. The vivid colors on most Chinese and Indian slate are the result of splitting the slate along natural layers, which exposes the metals to the atmosphere and causes them to rust.



FIGURE 7.53 A tile slate floor is combined nicely in this rusticated kitchen.

Courtesy of Showplace Wood Products, Inc.

Unlike granite and marble, slate—because it is nonporous—does not require a penetrating sealer, but a clear surface wax gives slate a wet look and enhances its color. Although slate scratches easily, marks that do not come off with normal cleaning usually can be removed with steel wool.

Soapstone

Soapstone earns kudos as a countertop for its resistance to chemicals and its appealing matte, smooth finish. One disadvantage: The maximum length of a slab of soapstone is 4 to 6 feet (1.2192 m to 1.8288 m), whereas granite slabs measure from 8 to 12 feet (2.4384 m to 3.6576 m) long. As for flooring, a low supply of soapstone has kept prices too high for widespread use.

Unlike granite and marble, soapstone—because it is nonporous— does not require a penetrating sealer. Treat soapstone with mineral oil monthly during the first year to speed the natural oxidation from light gray to a rich dark gray. After a year, clean with a standard household solution. Dents in soapstone can be feathered out with a block and sandpaper.

Terrazzo

An alternative to marble is terrazzo—a combination of marble, concrete, and cement that can be formed into a variety of configurations, such as a countertop with an integral sink.

Terrazzo is a slurry mixture of stone chips consisting of marble and cement. This marble aggregate concrete produces a hard and durable flooring surface. It is also used as a wall treatment.

It is available in field tiles of a more solid nature and decorative border tiles in various patterns and colors to match or contrast with the field tiles. Such a combination can provide a dramatic old-world look.

Travertine

Travertine begins as limestone, which, over time through geological shifting, has found its way deep in the earth. The porous nature of limestone makes it a great reservoir for liquids. Aquifers, which are enormous underground pools of water that feed our wells, were formed when the ice that covered much of the Earth melted. The water was absorbed by limestone. Heated by the earth's inner core, the water rises as steam and hot pressurized water to form geysers. This rising hot water dissolves the limestone and brings with it granules from below, forming mud beds on the surface. If enough time transpires and the mud beds cool, they will crystallize into solid stone called travertine.

Stone Installation Guidelines

To determine the exact measurements necessary for a countertop, once the base cabinets are in place, installers first create a template on site that adjusts for dimensional inconsistencies resulting from the settling of cabinetry and walls. Once the template is complete, a stone fabricator uses it to create the slabs, including the necessary cutouts, such as those for a sink. While most of the cutting and finishing is done at the fabricator's workshop, installers make minor cuts on site for a custom fit. The installers then place slabs together as tightly as possible, pack the joints with epoxy and adhesive, allow it to harden, and sand and buff the joints until they are almost invisible.

For flooring, a qualified installer cuts the tile to precise measurements on the job site, makes sure the slippage—the difference in face plane between tiles—falls within 1/12th of an inch of “true” (perfectly flat), and shuffles similar colors together to create a uniform appearance.

Although stone is many times heavier than man-made materials, it usually requires no special reinforcement of cabinetry or subflooring. Substrates between the joints and the stone floor, in order of preference according to rigidity, are a mortar or sand cement bed; a backer board of concrete and ash; and wood.

Slab versus Tile

Traditionally, stones are used in large slabs. Suppliers differ on the size and thickness of countertops they stock. Many slabs are available $1\frac{1}{4}$ inches thick. Other suppliers, however, stock $\frac{3}{4}$ -inch-thick countertops; some carry $1\frac{1}{2}$ -inch-thick slabs. The appearance of a $1\frac{1}{2}$ -inch-thick counter can be achieved by joining the $\frac{3}{4}$ -inch counter to a $\frac{3}{4}$ -inch edge treatment. If pieces are glued together, the seam will be noticeable. It is better to offset one $\frac{3}{4}$ -inch slab from the second $\frac{3}{4}$ -inch slab of stone to minimize the joint seam.

Alternatives are 6- by 6-inch, 12- by 12-inch, and 24- by 24-inch tiles that are installed by a tile setter following specifications developed by the Ceramic Tile Institute.

VINYL RESILIENT FLOORING

Better materials and the manufacturers' ability to improve photographic realism have improved the ability of vinyl to mimic natural materials, such as wood, marble, slate, granite and ceramic tile. However, the trend today in vinyl floor patterns is toward graphic simplicity that highlights simple, geometric patterns. Vinyl remains one of the easiest floors to maintain.

Vinyl Sheet

Vinyl sheet flooring is available as *inlaid* (the pattern going throughout the wear layer of vinyl) and as *rotogravure* (the pattern is printed on a sheet). Both are then covered with a layer of wearing surface. The thickness of the wear layer does not affect the durability of the floor or the price. Thick vinyl wear layers resist scuff and stains well but lose their gloss more quickly than a thinner urethane wear layer, which maintains a high-gloss surface better and provides a more scuff-resistant surface.

Vinyl sheet floor coverings range from having no cushion at all to a thick cushion beneath the wear layer. Although the thick cushion increases comfort, heavy objects can dent the vinyl.

Vinyl Tile

Solid or pure vinyl tiles are homogeneous vinyl that is unbacked and usually has uniform composition throughout. By far, the biggest seller is vinyl composition tile called vinyl tile.

Both solid (pure) and composition tile can be installed on suspended wood subfloors or over on-grade and below-grade concrete. They are durable and easily cleaned. Solid vinyl tiles do not have a wear layer topcoat. Composition vinyl tiles do have a wear layer top-coat and, therefore, are easier to maintain than pure vinyl tiles.

WALLPAPER

Within the kitchen and bathroom industry, a perplexing dilemma continually faces the designer—how to combine style with function. Wall coverings (see Figure 7.54) are often the planner's salvation.

Manufacturing Methods

The patterns in wall coverings are achieved by using two methods: machine prints and hand prints. In machine printing, all the wallpaper rolls are printed in a continuous run and are identical in color. Hand prints are printed by a process called silk screening and cannot be matched for color as closely as machine prints because each roll is individually hand-screened with slight color or variations occurring from roll to roll. To protect the hand print edges, the rolls are normally manufactured with selvages (untrimmed edges). A color variation will also occur in grass cloths and similar materials. The fibers from which they are made do not respond evenly to dyes; color gradually lightens or darkens from one edge of a strip to the other, and varies along the length of the roll.



FIGURE 7.54 Wallpaper is appropriate in both kitchens and bathrooms. In this bathroom, a Traditional pattern highlights the detailing of the iron pedestal lavatory.
Courtesy of Kohler Co.

Determining Quantities

The following procedure is suggested to determine wallpaper quantities for papers from American sources, which are based on Imperial sizes and generally have 60 square feet of product on each double roll.

- Measure the width of each wall to be prepared. Round the figure up to the next full foot measurement.
- Add the wall dimensions together.
- Multiply this figure by the ceiling height plus 4". Again, round up the figure to the next full foot measurement.
- Do not subtract the wall space covered by windows, doors, and appliances from the total square footage to be covered because the fall-off material must be discarded to maintain the match.
- Depending on the pattern match, divide the actual wall space to be covered as follows:
18" Repeat = Divide by 30
19" to 24" Repeat = Divide by 27
25" Repeat = Divide by 24
- Always round up to the next full number of rolls.

For papers, which are sized metrically, you can assume 28 to 30 square feet per roll. Therefore, you generally need to order twice the amount of product.

Job Site Considerations

The finished appearance of the wall covering can be only as good as the wall surface under it. The walls must be clean and smooth. Although foils are notorious for allowing imperfections to telescope through the covering, all wall coverings will reveal the surface below them to some extent. Walls must be properly sealed. The correct adhesive for the wall covering must be used.

Always open all rolls and inspect them for color match or defects before any installation begins. Because dye lots vary, it is important to check the material before installation begins. This same concern prohibits the installation of part of the wall covering before all the material ordered arrives.

SUMMARY

The variety of equipment and materials available for the kitchen and bathroom is extensive. Designers must have a broad base of knowledge to help them differentiate between the major categories. The information in this volume of the NKBA Professional Resource Library will help the designer reach this first plateau of product knowledge.

Once you have mastered this information, concentrate your efforts on learning everything you can about the specific surfacing products you represent. Visit the manufacturing facility, if possible. Spend time with your distributor's representative learning about individual materials. Review possible products with your fabricator and installation experts as well.

Next, commit yourself to faithfully reading trade journals and attending local, regional, and product exhibitions so your surface material knowledge will be expanded each year of your professional practice. Regularly visiting reputable Web sites and attending webinars presented by respected manufacturers is an excellent way to continue your education.

Knowing all that is available is still not enough. You must challenge yourself to creatively combine the products available to you.

REVIEW QUESTIONS

1. Explain the difference between a prefinished wood countertop and a polyurethane-finished wood countertop. (See "Wood Sealed with Polyurethane" page 235)
2. What does the term "crazing" mean as it relates to cast polymer bathroom fixtures? (See "Gel Coat Application" page 237)
3. What is the base material of a glazed tile versus a quarry tile? (See "Types of Tile" pages 240 and 246)
4. Can you use nonsanded grout in a tile installation with grout lines $\frac{1}{2}$ -inch thick? (See "Grouts" page 250)
5. Concrete countertops can only be installed in place. [True or False] (See "Concrete" page 257)
6. Describe the difference between a laminate wood floor and a renewable bamboo floor. (See "Renewable Bamboo Flooring" page 262)
7. Describe the difference among flat paint, semigloss paint, and high-gloss paint. (See "Paint Gloss Choices" page 268)
8. What is the difference between a quartz countertop and a granite countertop from a core material standpoint? (See "Quartz Composite" page 269)
9. List three advantages of solid surfacing material relating to durability of product. (See "Solid Surfacing" page 271)
10. Explain what the marble classifications of A, B, C, and D are based on. (See "Coloration and Durability" page 279)
11. What is the difference between vinyl flooring that are inlaid as opposed to rotogravure? (See "Vinyl Sheet" page 282)

APPENDIX

Generic Cabinet Nomenclature



FRAMED CABINETS—IMPERIAL MEASUREMENTS

(Courtesy of David Newton Associates)

Base Cabinet Nomenclature

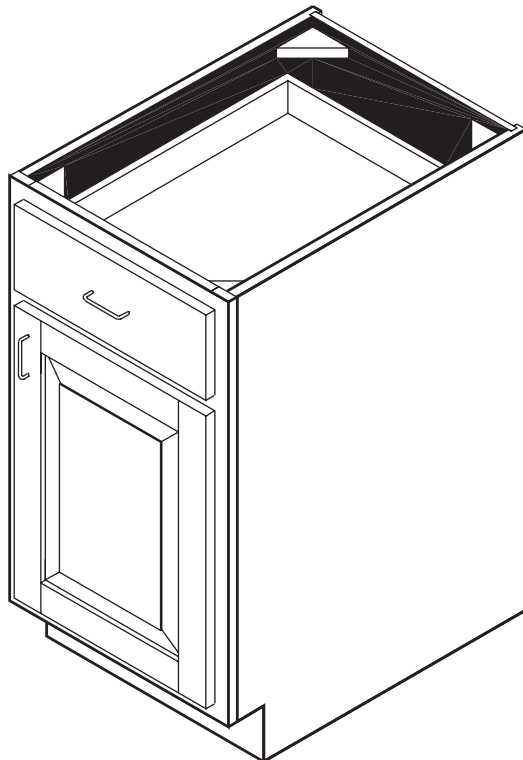

FIGURE A.1 9 3 BASE CABINET
(B12R • B15R • B18R • B21R • B24R)
Base cabinet with one door and one
drawer. Specify hinging L or R. Right
shown.

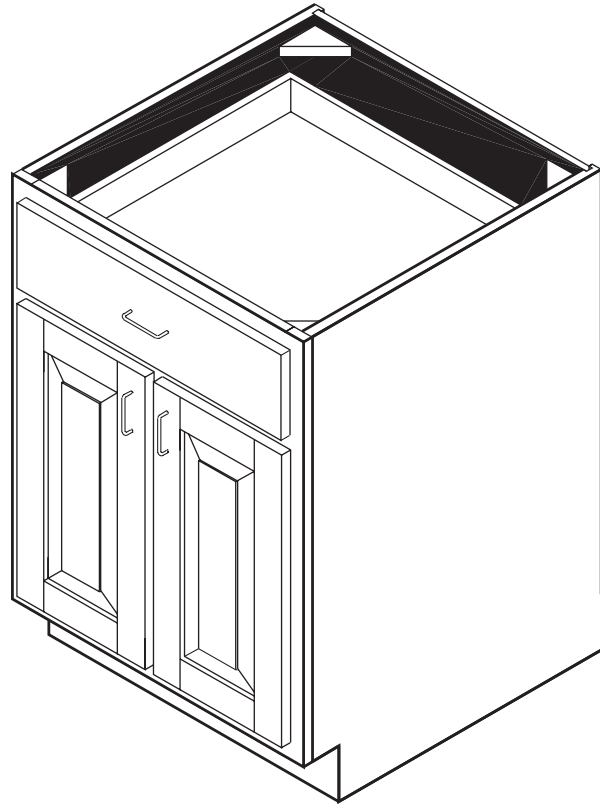

FIGURE A.2 BASE CABINET (BUTT DOORS) (B24) Base cabinet with two doors and one drawer. Doors butt together at center of cabinet opening. No center stile.

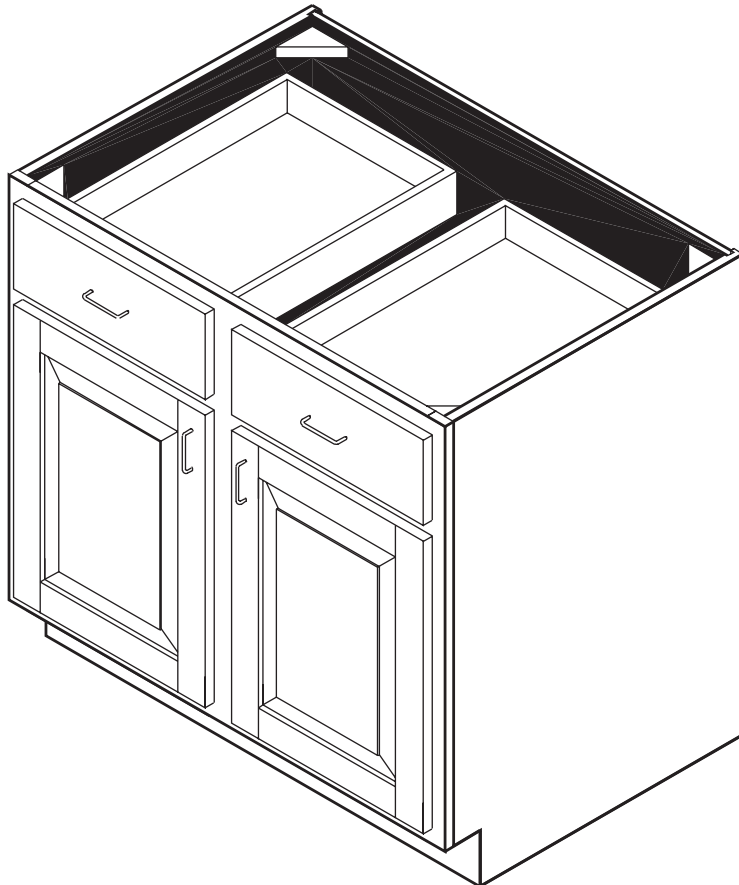

FIGURE A.3 BASE CABINET (B27 • B30 • B33 • B36 • B39 • B42 • B45 • B48) Base cabinet with two doors and two drawers.

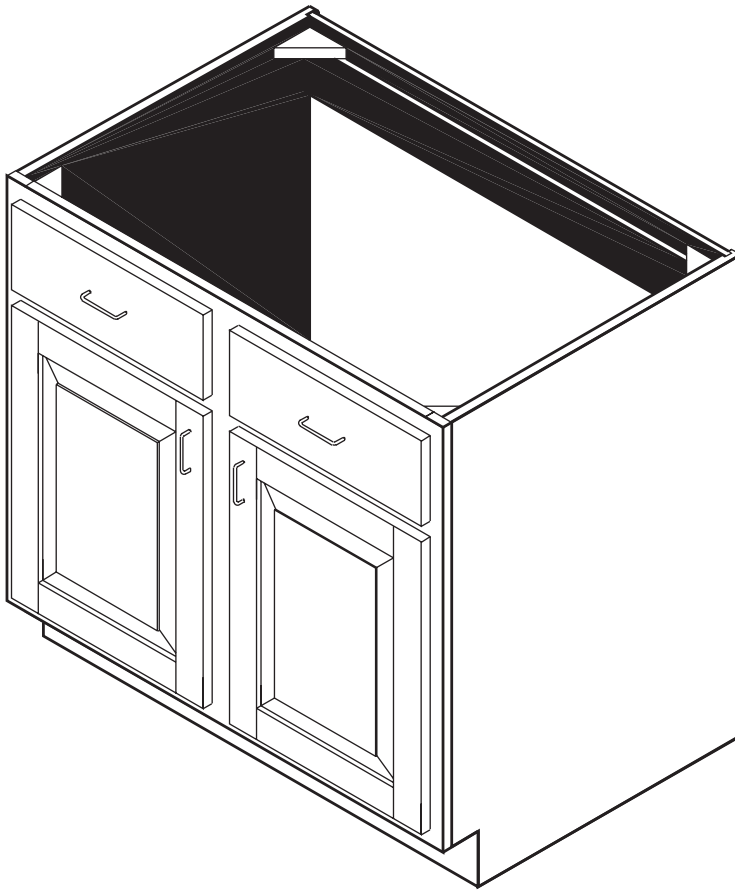

FIGURE A.4 SINK BASE CABINET
9SB24 • SB27 • SB30 • SB33 • SB36
• SB39 • SB42 • SB45 • SB48) Base
cabinet with a shelf but without
drawers.



FIGURE A.5 9 5 THREE DRAWER BASE
CABINET (3DB12 • 3DB15 • 3DB18
• 3DB21 • 3DB24 • 3DB30 • 3DB36.
Base cabinet with three drawers.
3DB36 shown.



FIGURE A.6 FOUR DRAWER BASE CABINET (4DB12 • 4DB15 • 4DB18 • 4DB21) Base cabinet with four drawers.

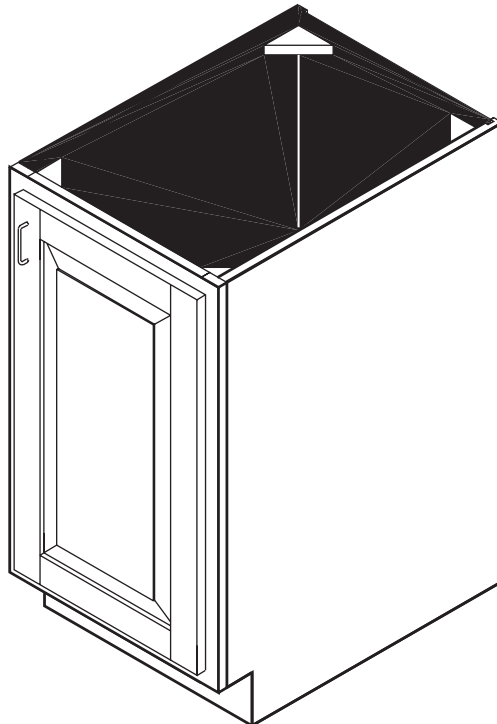

FIGURE A.7 FULL-HEIGHT BASE CABINET (FHB9R • FHB12R • FHB15R • FHB18R • FHB21R • FHB24R) Base cabinet with full-height door, no drawer. Specify hinging L or R. Right shown.

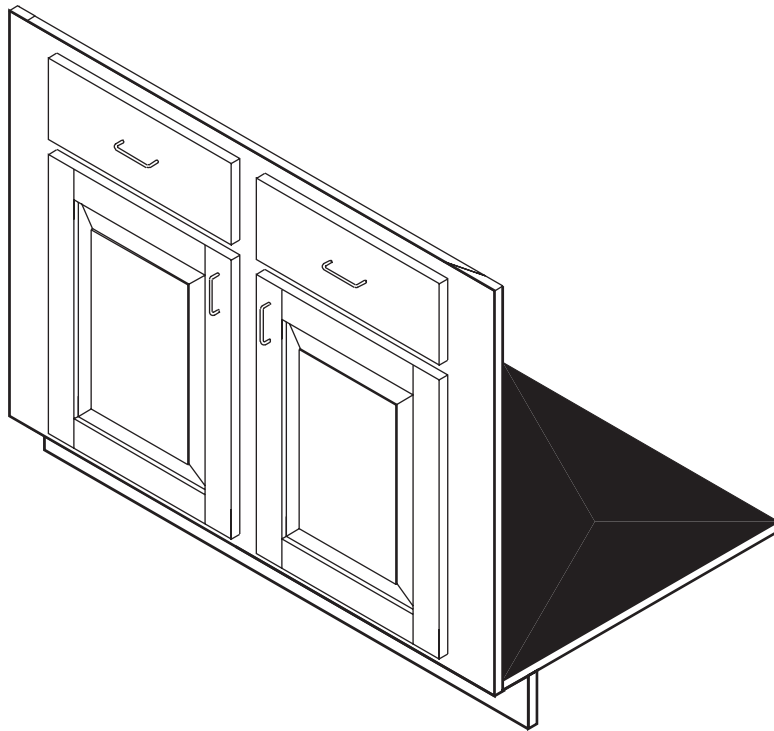

FIGURE A.8 SINK OR RANGE FRONT (FRAME ONLY) (SF24 • SF30 • SF36 • SF42 • SF48) Front of cabinet only, with floor. Wide stiles allow 6" adjustment in width.

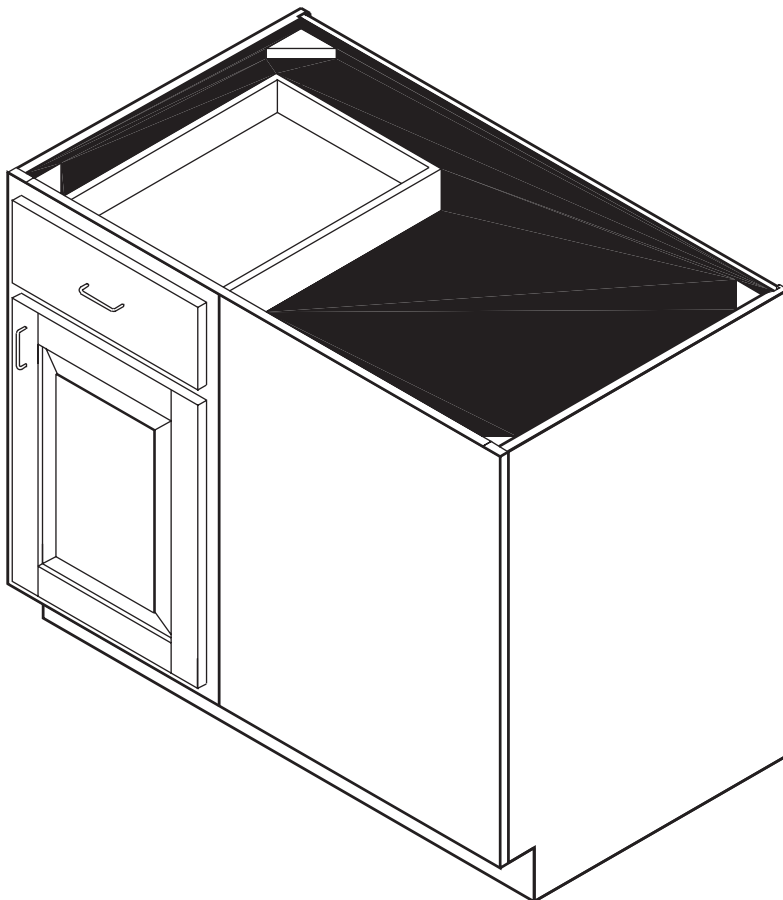

FIGURE A.9 BLIND BASE CORNER CABINET (BBC36 • BBC39 • BBC42 • BBC45 • BBC48) Reversible blind base corner cabinet. Can be pulled up to 5 1/2". A BF3 filler must be ordered for proper installation. Door and drawer may be moved to opposite side to reverse blind. Blind right shown.

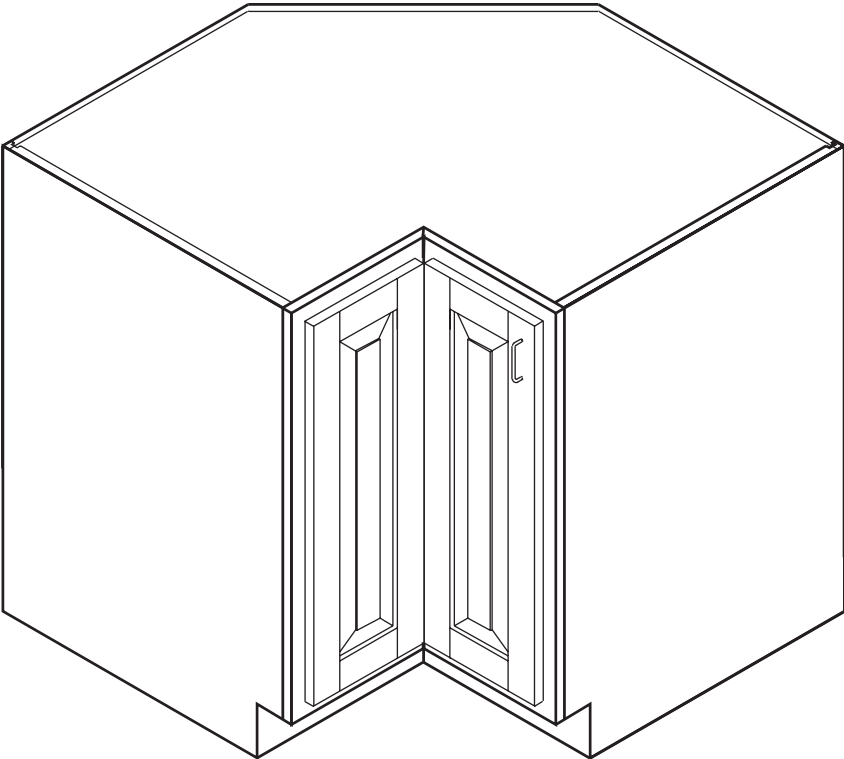

FIGURE A.10 L-CORNER BASE CABINET (LCB36L) "L" shaped base corner cabinet. Specify hinging L or R. Left shown.

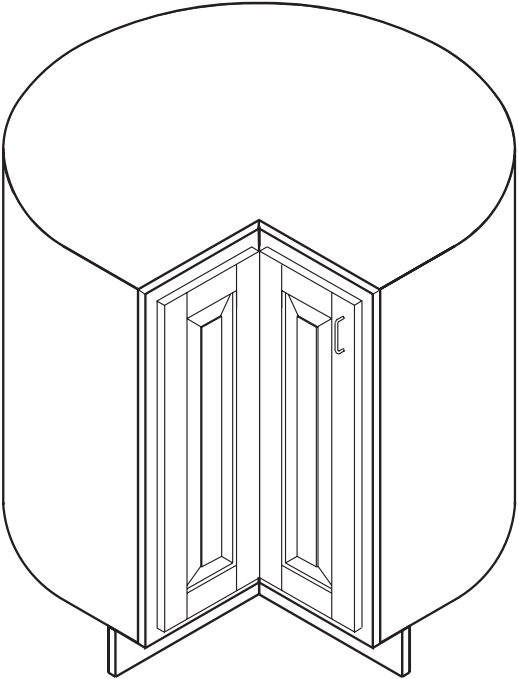

FIGURE A.11 LAZY SUSAN BASE CORNER CABINET (LSB33L • LSB36L) Revolving shelf Lazy Susan corner base cabinet. Specify hinging L or R. Left shown.

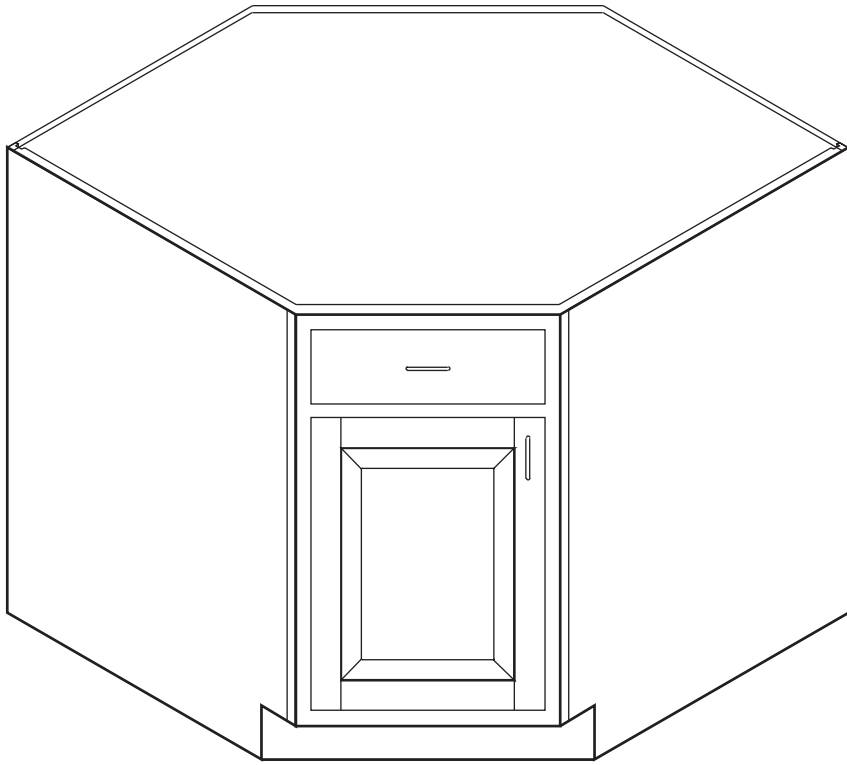

FIGURE A.12 DIAGONAL CORNER BASE CABINET (DCB36L) Diagonal base cabinet for corner application. Specify hinging L or R. Left shown.

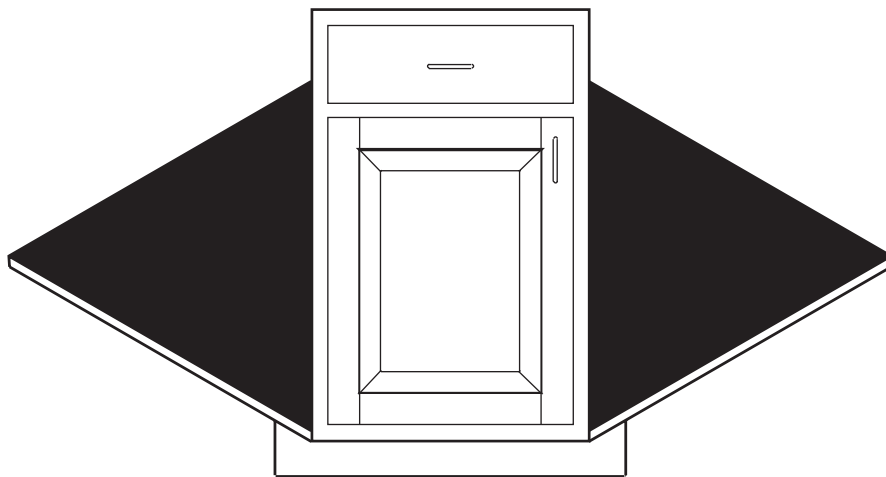

FIGURE A.13 DIAGONAL CORNER FRONT (DCF36L • DCF39L • DCF42L) Diagonal base front with floor, for corner application. Specify hinging L or R. Left shown.

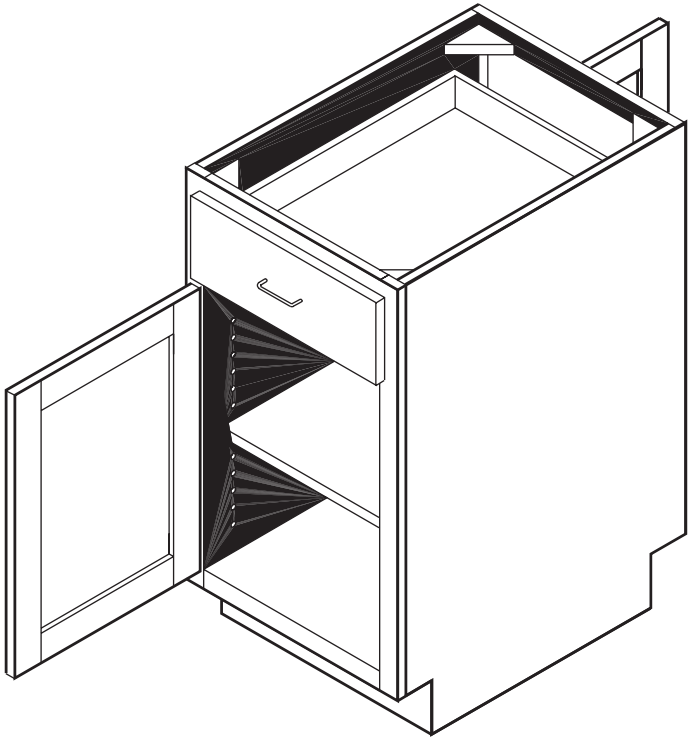

FIGURE A.14 BASE PENINSULA CABINET (BP12L • BP18L • BP24L) Base cabinet with two doors and one drawer. Specify hinging L or R. Left shown.

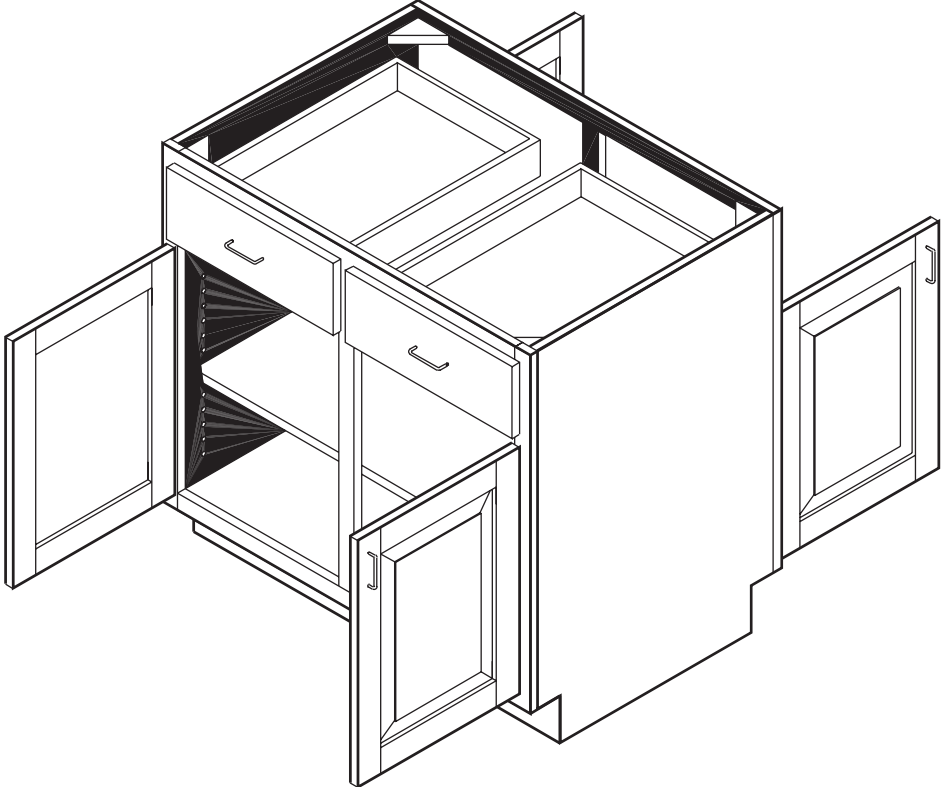

FIGURE A.15 BASE PENINSULA CABINET (BP24 • BP30 • BP36 • BP42 • BP48) Base cabinet with four doors and two drawers

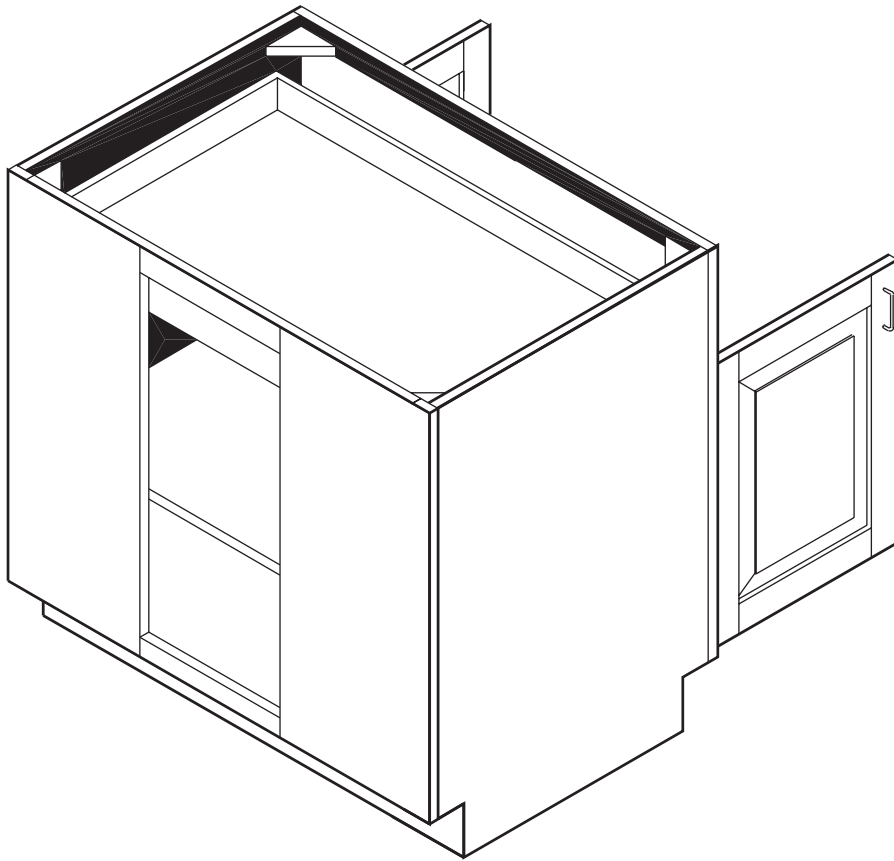

FIGURE A.16 BASE CORNER PENINSULA CABINET (BCP27) Base corner cabinet with two doors and one drawer. Used as a blind corner base cabinet when planning peninsula cabinets. This 27" wide cabinet eliminates the need for a filler on the inside corner of the kitchen layout. A filler must be planned for any item placed at 90° to the BCP27. Blinded view shown.

Wall Cabinet Nomenclature

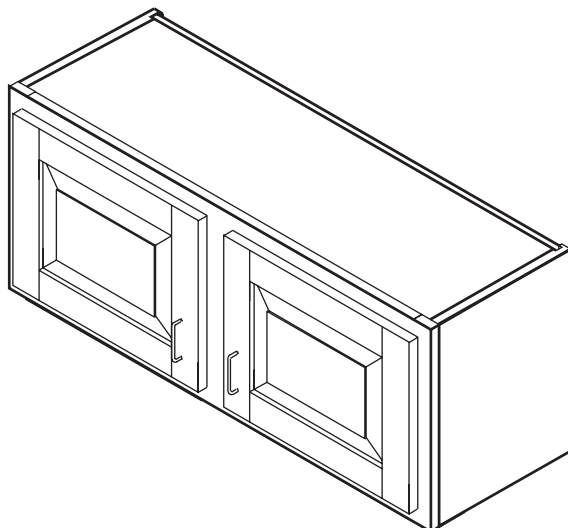

FIGURE A.17 12" AND 15" HIGH WALL CABINETS (W3012 • W3312 • W3612 • W3912 • W4212) 12" high wall cabinets.
W3015 • W3315 • W3615 • W3915 • W4215
15" high wall cabinets.

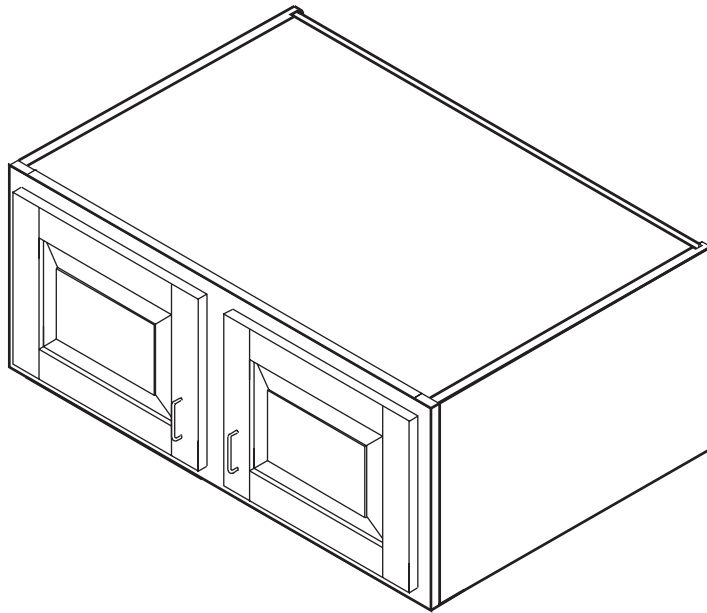

FIGURE A.18 12" AND 15" HIGH WALL CABINETS 24" DEEP
W301224 • W331224 • W361224
• W391224 • W421224 • W481224
12" high wall cabinets, 24" deep.
W301524 • W331524 • W361524
• W391524 • W421524 • W481524
15" high wall cabinets, 24" deep.

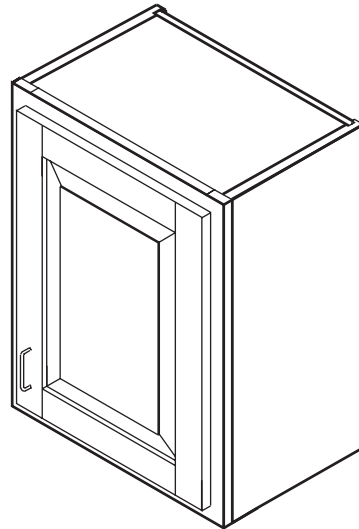

FIGURE A.19 18" AND 24" HIGH WALL CABINETS W1818R • W2118R • W2418R 18" high wall cabinet, single door. Specify hinging L or R. Right shown.
W1824R • W2124R • W2424R
24" high wall cabinet, single door. Specify hinging L or R. Right shown.

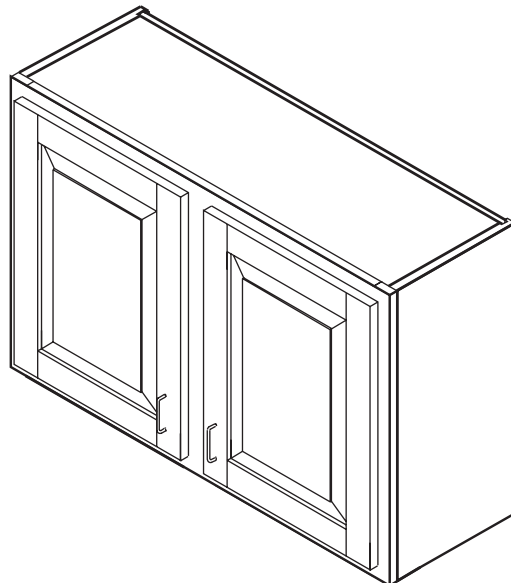

FIGURE A.20 18" AND 24" HIGH WALL CABINETS
W2718 • W3018 • W3318 • W3618
• W3918 • W4218
18" high wall cabinets.
W2724 • W3024 • W3324 • W3624
• W3924 • W4224
24" high wall cabinets.

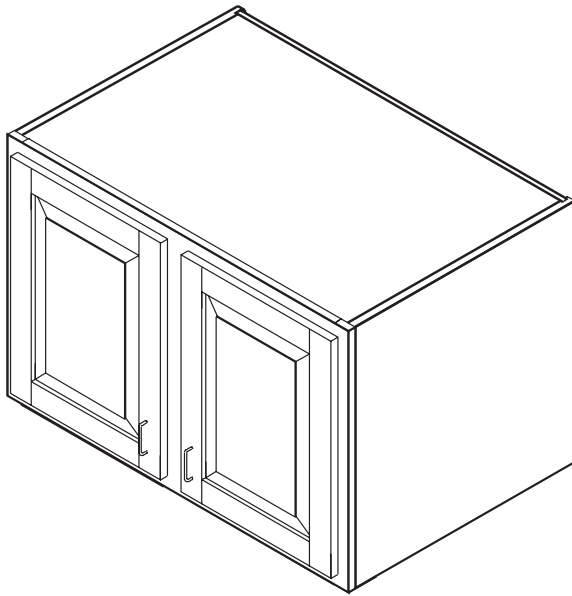

FIGURE A.21 18" AND 24" HIGH WALL CABINETS 24" DEEP
 W301824 • W331824 • W361824
 • W391824 • W421824
 18" high wall cabinets, 24" deep.
 W302424 • W332424 • W362424
 • W392424 • W422424
 24" high wall cabinets, 24" deep.

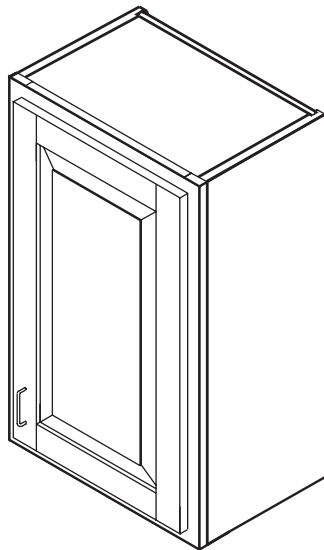

FIGURE A.22 30" HIGH WALL CABINETS
 W930R • W1230R • W1530R
 • W1830R • W2130R • W2430R
 30" high wall cabinets, single door.
 Specify hinging L or R. Right shown.

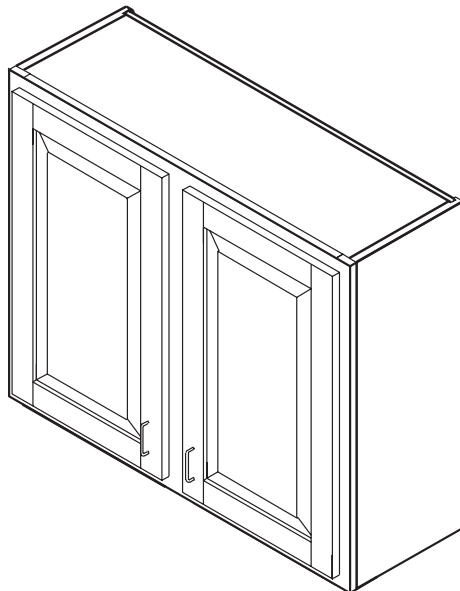

FIGURE A.23 30" HIGH WALL CABINETS
 W2430 • W2730 • W3030 • W3330
 W3630 • W3930 • W4230
 • W4530 • W4830
 30" high wall cabinets.

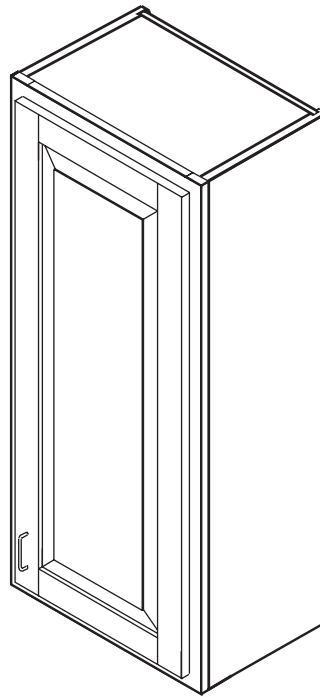

FIGURE A.24 36" AND 42" HIGH WALL CABINETS

W936R • W1236R • W1536R
• W1836R • W2136R • W2436R
36" high wall cabinets, single door.
Specify hinging L or R. Right shown.
W942R • W1242R • W1542R
• W1842R • W2142R • W2442R
42" high wall cabinets, single door.
Specify hinging L or R. Right shown.

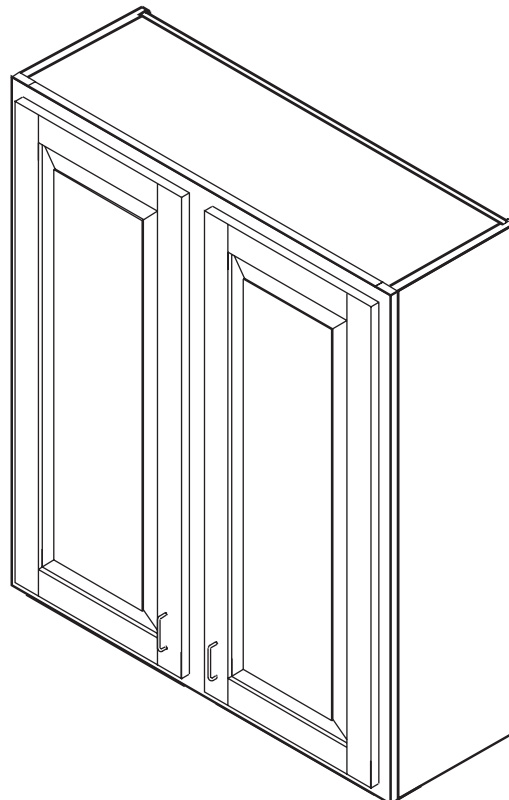

FIGURE A.25 36" AND 42" HIGH WALL CABINETS

W2436 • W2736 • W3036 • W3336
• W3636 • W3936 • W4236
36" high wall cabinets.
W2442 • W2742 • W3042 • W3342
• W3642 • W3942 • W4242
42" high wall cabinets.

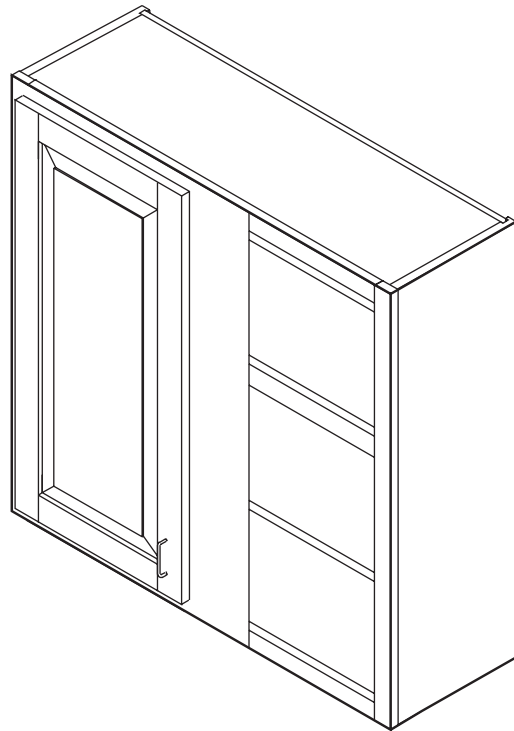

FIGURE A.26 BLIND CORNER WALL CABINET

Must order a WF3 filler for proper installation.

- BCW2430R • BCW3030R
- BCW3630R • BCW4230R
- BCW4830R

30" high wall corner cabinet for corner application. Specify blind L or R. Right shown.

- BCW2436R • BCW3036R
- BCW3636R • BCW4236R
- BCW4836R

36" high wall corner cabinet for corner application. Specify blind L or R. Right shown.

- BCW2442R • BCW3042R
- BCW3642R

42" high wall corner cabinet for corner application. Specify blind L or R. Right shown.

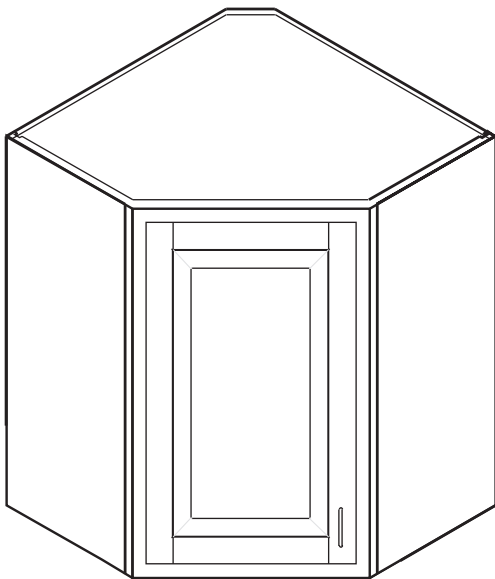

FIGURE A.27 DIAGONAL CORNER WALL CABINET

- DCW2430L • DCW2436L • DWC2442L

Diagonal corner wall cabinet for corner applications. Specify hinging L or R. Left shown. Three heights: 30", 36", 42".

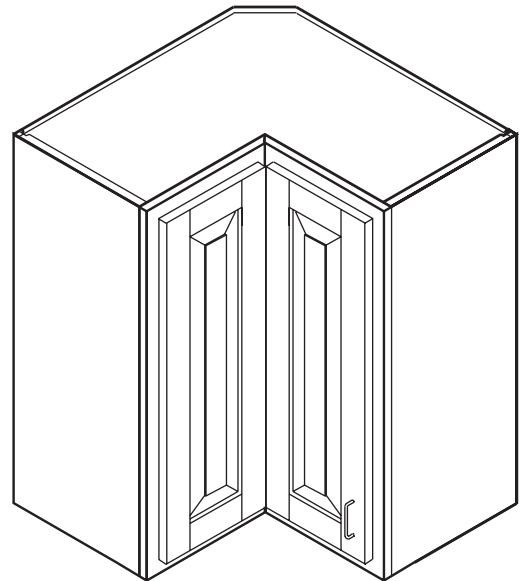

FIGURE A.28 "L" CORNER WALL CABINET

- LCW2430L • LCW2436L • LCW2442L

"L" corner wall cabinet for corner applications. Specify hinging L or R. Left shown. Three heights: 30", 36", 42".

FIGURE A.29 DIAGONAL CORNER WALL CABINET WITH APPLIANCE PANTRY
DCWAP2430L • DCWAP2436L
• DCWAP2442L
Diagonal corner wall cabinet with appliance storage for open corner applications.
Specify hinging L or R. Left shown.
Three heights: 30", 36", 42".

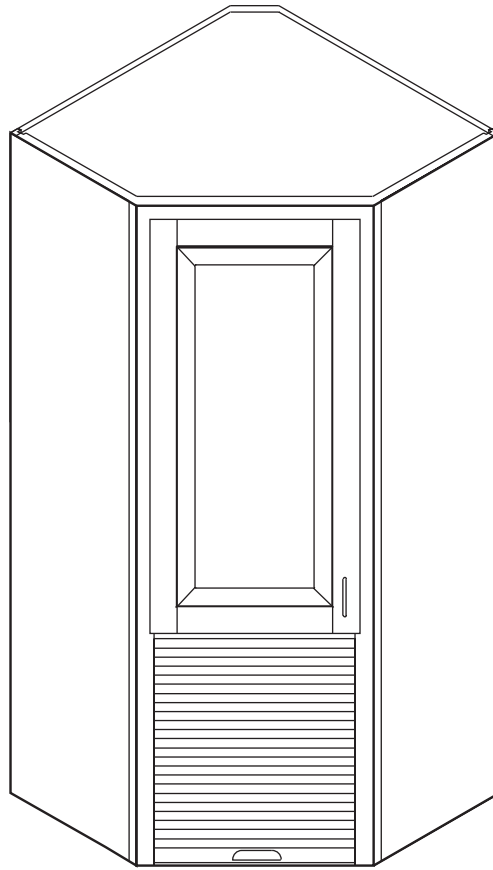
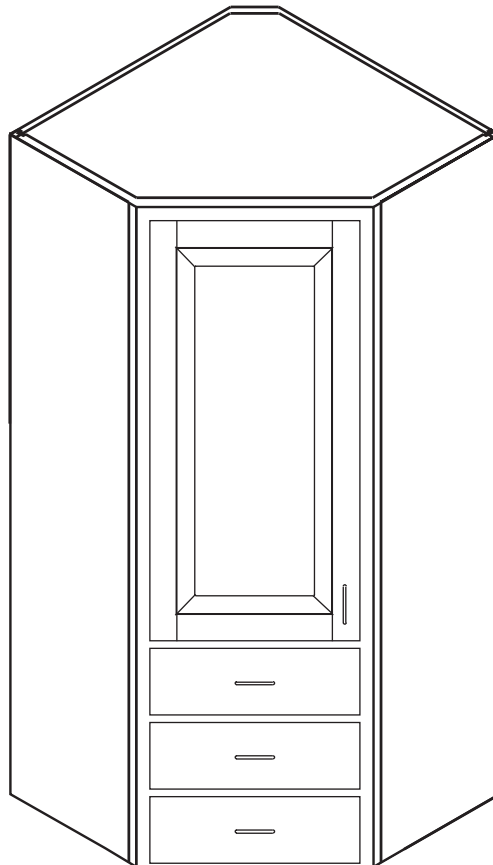

FIGURE A.30 DIAGONAL CORNER WALL CABINET WITH THREE DRAWERS
DCW3D2430L • DCW3D2436L
• DCW3D2442L
Diagonal corner wall cabinet with drawer storage for corner applications.
Specify hinging L or R. Left shown.
Three heights: 30", 36", 42".



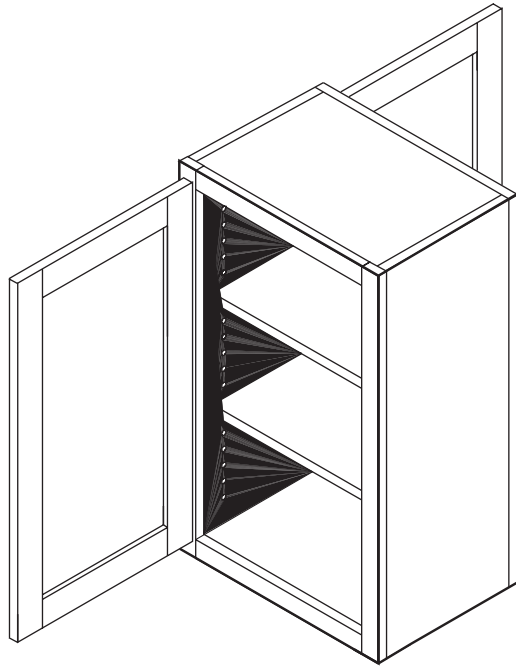

FIGURE A.31 WALL PENINSULA CABINETS

WP1224L • WP1524L • WP1824L
 • WP2124L • WP2424L

24" high wall cabinets, two doors.
 Specify hinging L or R. Left shown.

WP1230L • WP1530L • WP1830L
 • WP2130L • WP2430L

30" high wall cabinets, two doors.
 Specify hinging L or R. Left shown.

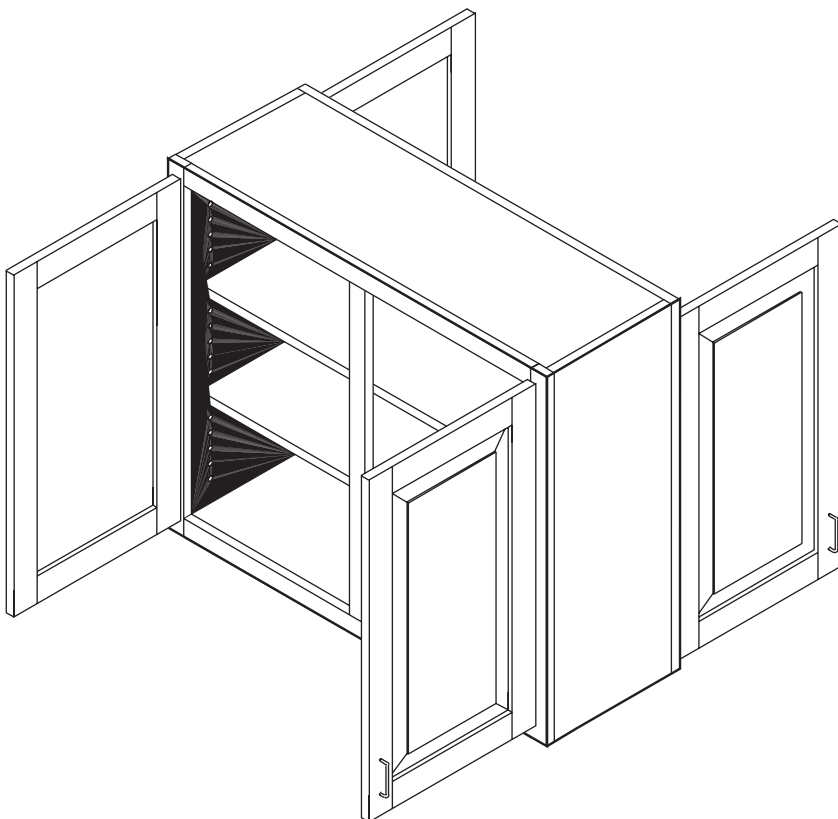

FIGURE A.32 WALL PENINSULA CABINETS

WP2424 • WP3024 • WP3624
 • WP4224 • WP4824

24" high wall cabinets, four doors.
 WP2430 • WP3030 • WP3630

• WP4230 • WP4830

30" high wall cabinets, four doors.

Tall Cabinet Nomenclature

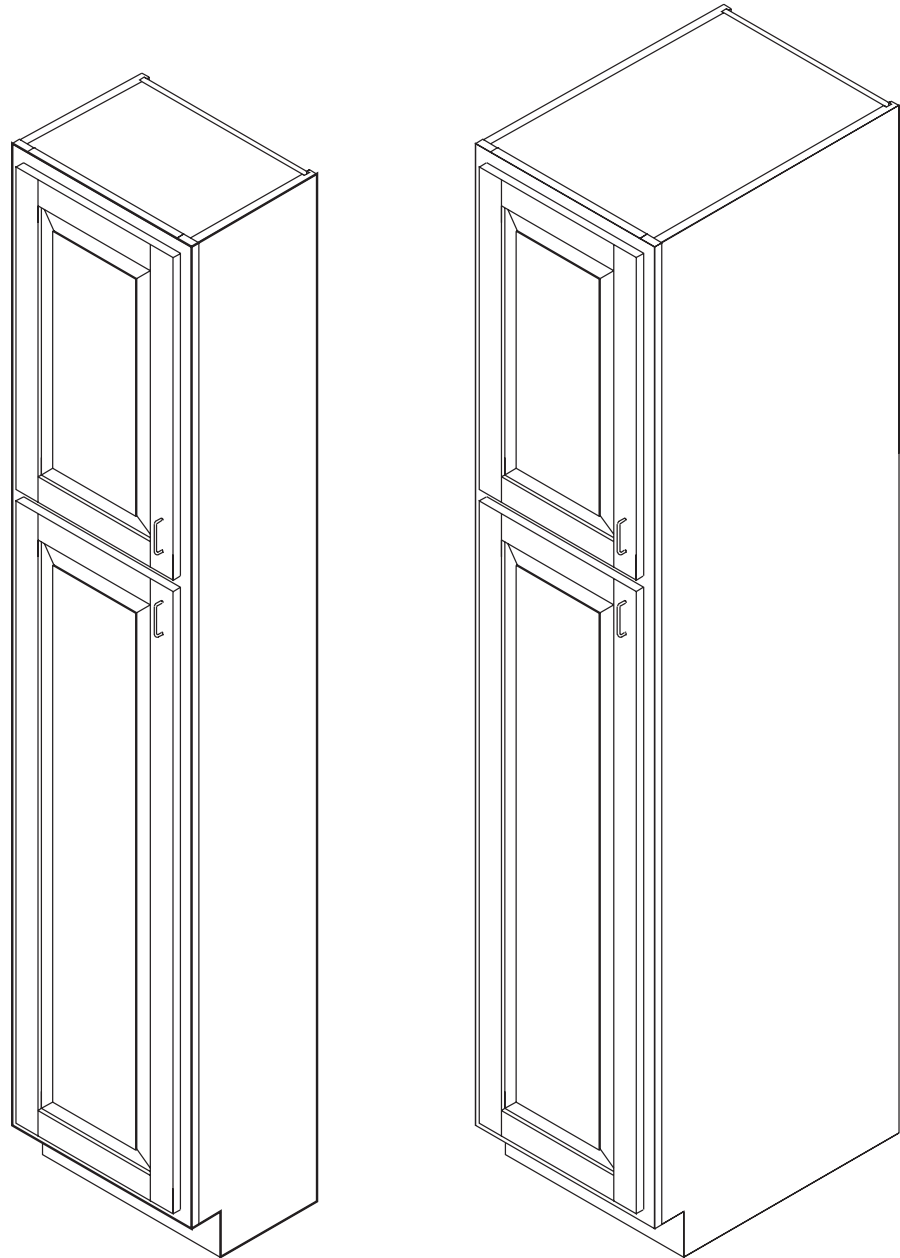

FIGURE A.33 12" DEEP UTILITY CABINETS

U151284L • U181284L • U241284L

Single door, 12" deep, 84" high utility cabinets. Specify hinging L or R. Left shown.

U151290L • U181290L • U241290L

Single door, 12" deep, 90" high utility cabinets. Specify hinging L or R. Left shown.

U151296L • U181296L • U241296L

Single door, 12" deep, 96" high utility cabinets. Specify hinging L or R. Left shown.

24" DEEP UTILITY CABINETS

U152484L • U182484L • U242484L

Single door, 24" deep, 84" high utility cabinets. Specify hinging L or R. Left shown.

U152490L • U182490L • U242490L

Single door, 24" deep, 90" high utility cabinets. Specify hinging L or R. Left shown.

U152496L • U182496L • U242496L

Single door, 24" deep, 96" high utility cabinets. Specify hinging L or R. Left shown.

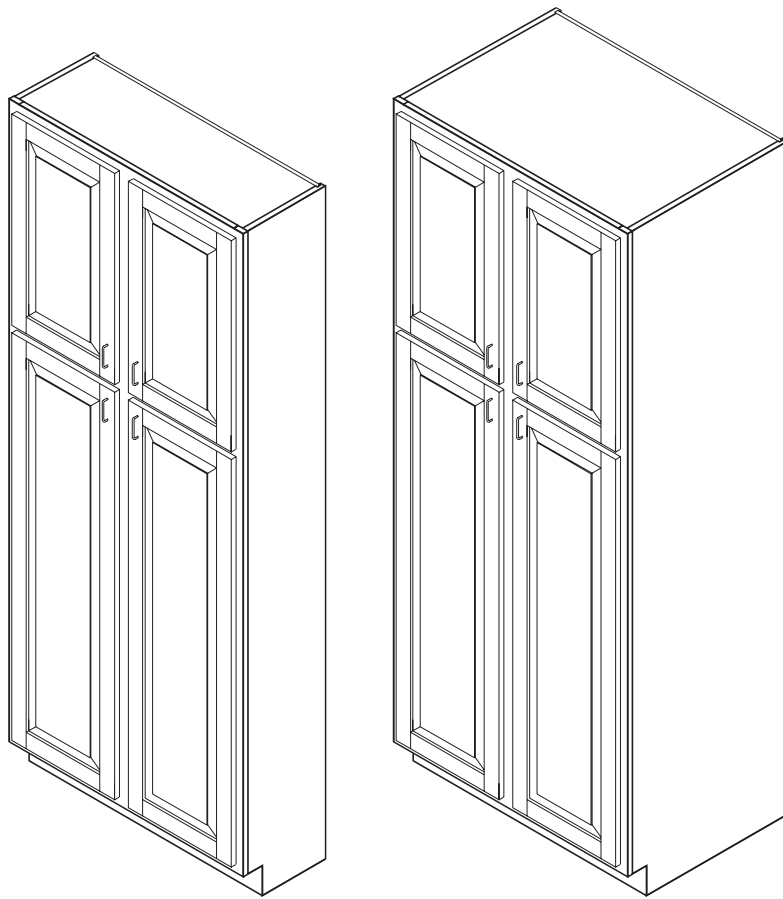

FIGURE A.34 12" DEEP UTILITY CABINETS

U241284 • U301284 • U361284
Double door, 12" deep, 84" high utility cabinets.

U241290 • U301290 • U361290
Double door, 12" deep, 90" high utility cabinets.

U241296 • U301296 • U361296
Double door, 12" deep, 96" high utility cabinets.

24" DEEP UTILITY CABINETS

U242484 • U302484 • U362484
Double door, 24" deep, 84" high utility cabinets.

U242490 • U302490 • U362490
Double door, 24" deep, 90" high utility cabinets.

U242496 • U302496 • U362496
Double door, 24" deep, 96" high utility cabinets.

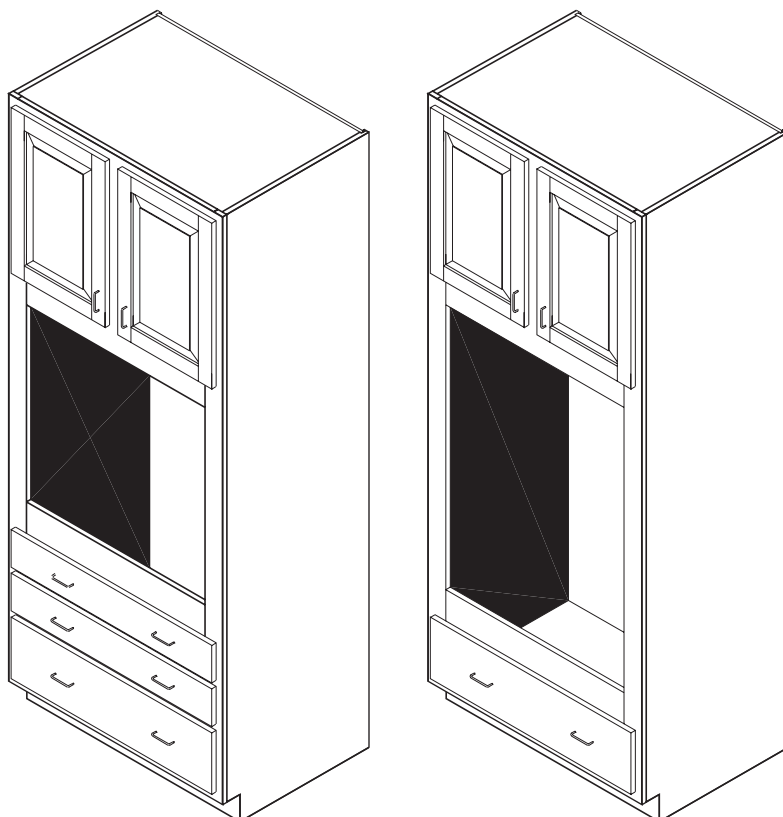

FIGURE A.35 SINGLE OVEN CABINET

S02784 • S03084 • S03384

• S03684

Universal single oven cabinet, 84" high.

S02790 • S03090 • S03390

• S03690

Universal single oven cabinet, 90" high.

S02796 • S03096 • S03396

• S03696

Universal single oven cabinet, 96" high.

DOUBLE OVEN CABINET

DO2784 • DO3084 • DO3384

• DO3684

Universal double oven cabinet, 84" high.

DO2790 • DO3090 • DO3390

• DO3690

Universal double oven cabinet, 90" high.

DO2796 • DO3096 • DO3396

• DO3696

Universal double oven cabinet, 96" high.

Filler Nomenclature

FIGURE A.36 TALL FILLERS (TF3 • TF6)

96" high in two widths (3" and 6")
 Fillers can be cut in height and width for correct fit.

BASE FILLERS (BF3 • BF6) 34½" high in two widths (3" and 6")
 Fillers can be cut in height and width for correct fit.

WALL FILLERS (WF3 • WF6) 30" high in two widths (3" and 6")
 Fillers can be cut in height and width for correct fit.

For taller wall fillers, order TF3 or TF6.
 CORNER FILLERS (CBF3 • CWF3)
 Corner wall fillers can be cut in height.

Both base and wall fillers can be cut in width.
 FULL OVERLAYS (TF03 • TF06 • BF03 • BF06 • WF03 • WF06)
 Overlays are available for all standard fillers.

Designed for use with full-overlay door styles. Specify door style to match door material, finish and edging profile.

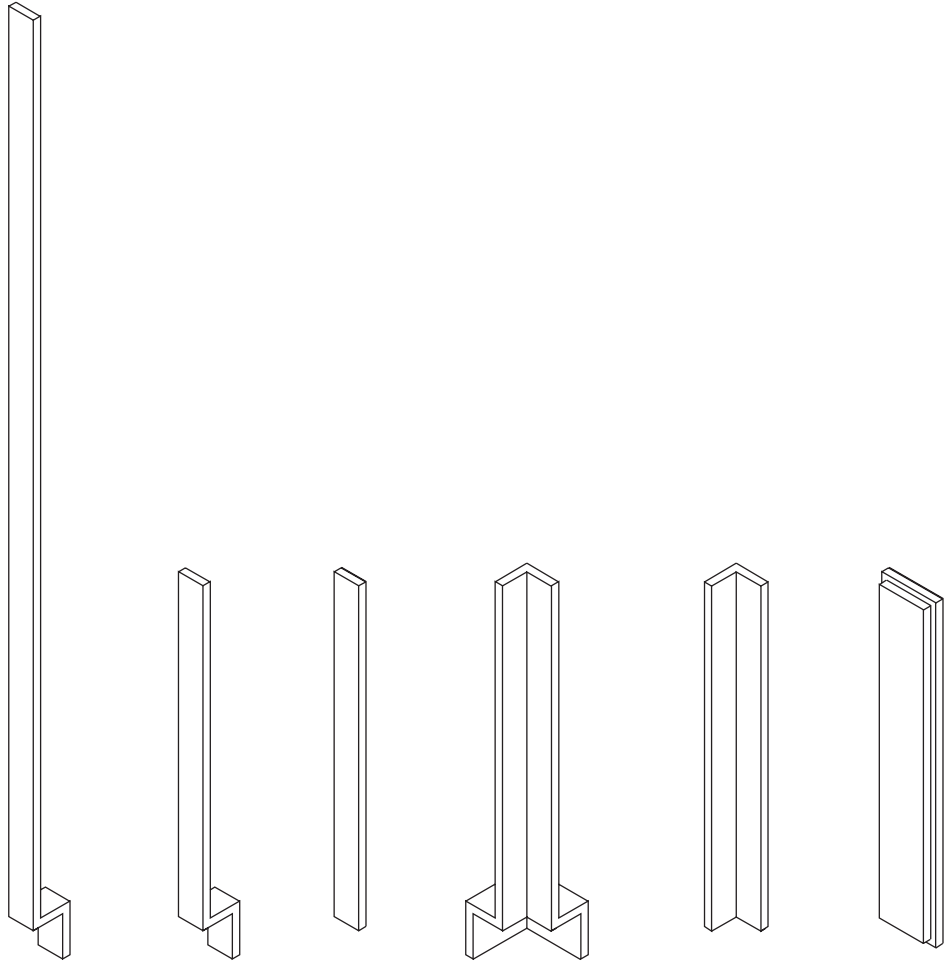

Specialty Base Cabinet Nomenclature

FIGURE A.37 12" BASE END CABINETS (BEC12R) 12" wide base end cabinet. Specify L or R. Right shown.

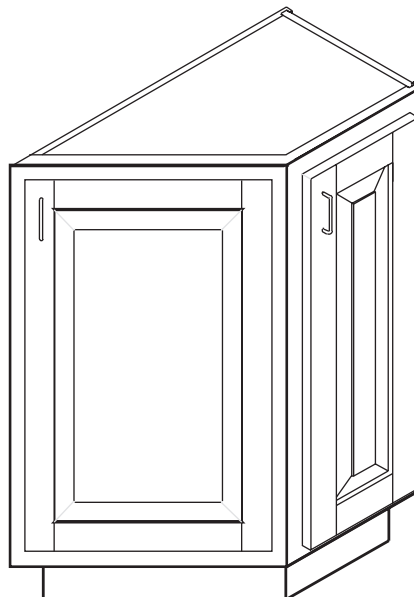

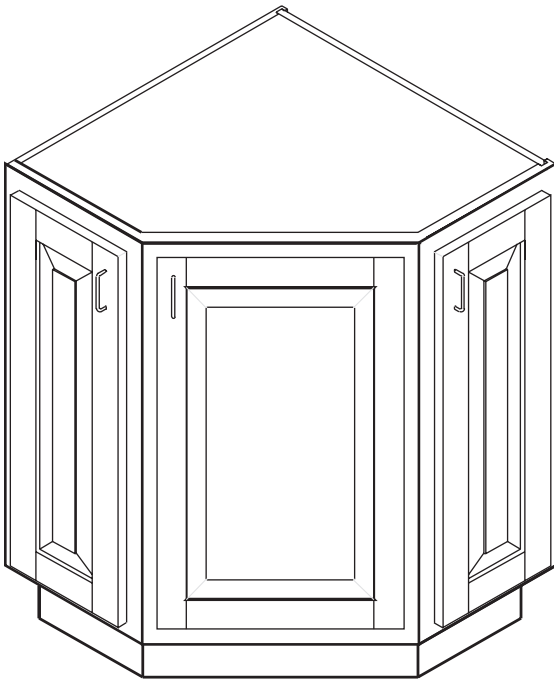

FIGURE A.38 24" BASE END CABINETS (BEC24R) 24" wide base end cabinet. Specify L or R. Right shown.

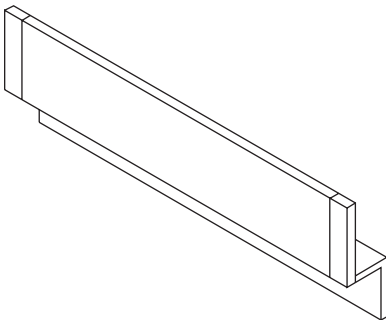

FIGURE A.39 30" DROP-IN RANGE PANEL (RP30) A 30" wide panel placed below a drop-in range. Height is adjusted to fit a drop-in range. Toekick is attached.

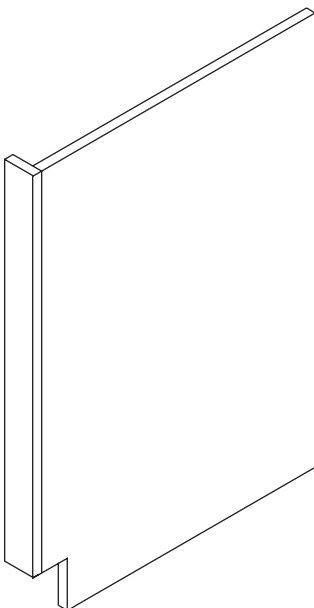

FIGURE A.40 END PANEL (BEP-3R SHOWN) (WEP • WEP1 $\frac{1}{2}$ • WEP 3) Wall end panels 12" deep and 30" high without toekick notch shown above. Reverse for R or L. (BEP • BEP1 $\frac{1}{2}$ • BEP 3) A base panel usually placed beside a dishwasher at the end of a base cabinet run. Stile widths of $\frac{3}{4}$ ", 1 $\frac{1}{2}$ " and 3". Larger sizes can be reduced in width. Specify L or R. Right shown. (TEP • TEP1 $\frac{1}{2}$ • TEP 3) A tall panel usually placed beside a refrigerator. Widths of $\frac{3}{4}$ ", 1 $\frac{1}{2}$ " and 3". The two larger sizes can be trimmed to a smaller dimension. No toekick. Reverse R or L.

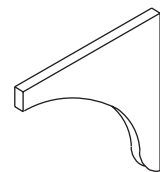

FIGURE A.41 COUNTERTOP BRACKET (CORBEL) (CB) 12" x 12" bracket to support countertop.

Specialty Wall Cabinet Nomenclature

FIGURE A.42 MICROWAVE WALL CABINET (MWC2434 • MWC2734 • MWC3034) Microwave shelf with storage above. Use with 30" high wall cabinets. (MWC2440 • MWC2740 • MWC3040) Microwave shelf with storage above. Use with 36" high wall cabinets. (MWC2446 • MWC2746 • MWC3046) Microwave shelf with storage above. Use with 42" high wall cabinets.

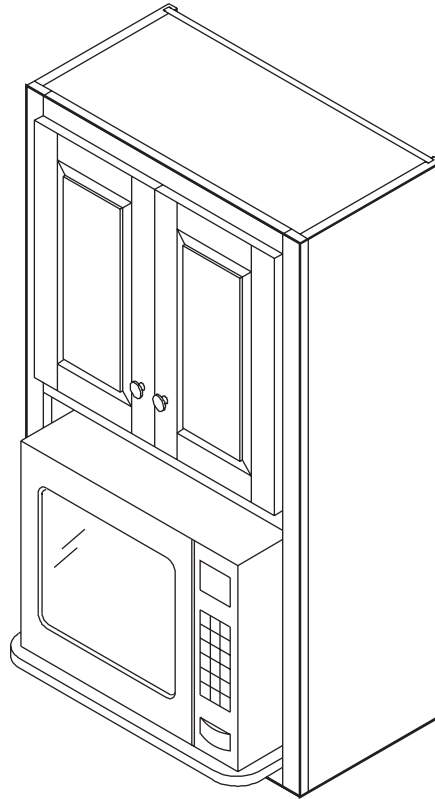
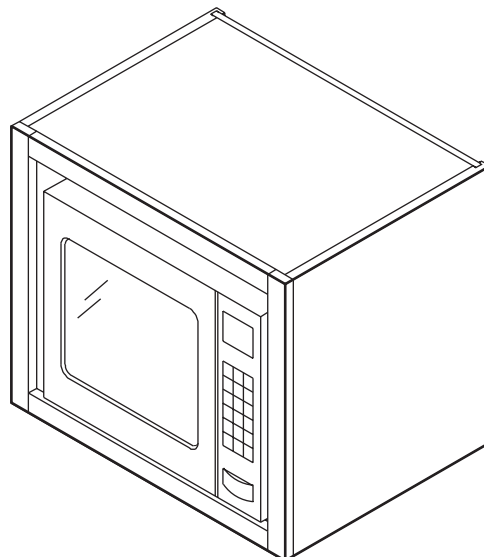

FIGURE A.43 MICROWAVE WALL SHELF (MWS242118 • MWS302118) 18" deep microwave box with shelf. Placed below varied height wall cabinets to position microwave bottom for user's height. Two widths: 24" and 30".



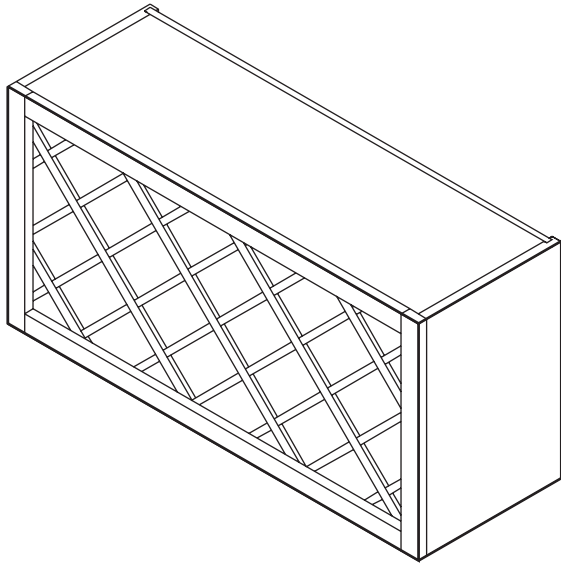

FIGURE A.44 WINE RACK WALL CABINET (WR3018 • WR3618) 18" high wall cabinet for bottle storage. Can be mounted vertically. (WR3024 • WR3624) 24" high wall cabinet for bottle storage. Can be mounted vertically. (WR3030 • WR3630) 30" high wall cabinet for bottle storage.

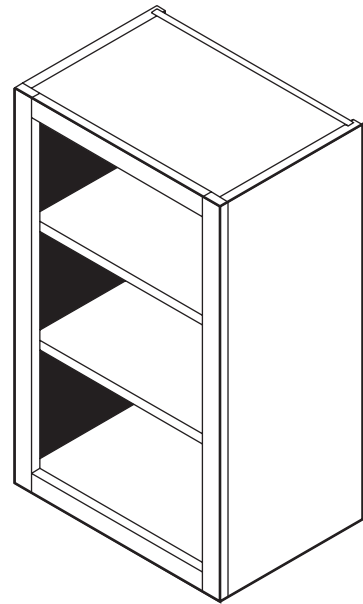

FIGURE A.45 30" HIGH WALL OPEN CABINET (WO930 • WO1230 • WO1530 • WO1830 • WO2130 • WO2430) 30" high wall cabinets without a door.

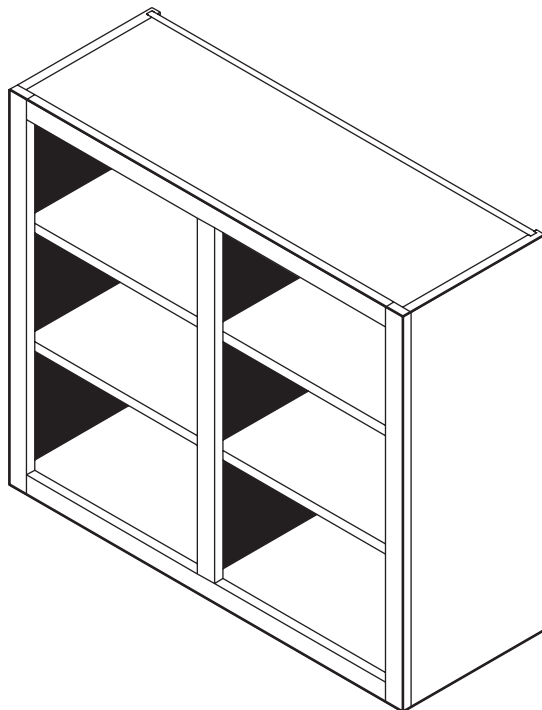

FIGURE A.46 30" HIGH WALL OPEN CABINET (WO2430 • WO2730 • WO3030 • WO3330 • WO3630 • WO3930 • WO4230 • WO4530 • WO4830) 30" high wall cabinets without doors.

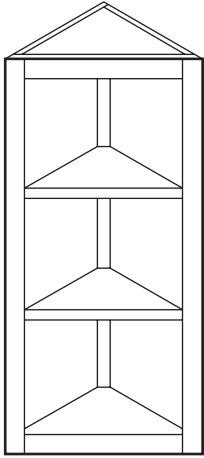

FIGURE A.47 WALL END CABINETS (WEC1230R) 30" high wall end cabinets. Order with or without door. Specify L or R. (WEC1236R) 36" high wall end cabinets. Order with or without door. Specify L or R. (WEC1242R) 42" high wall end cabinets. Order with or without door. Specify L or R.

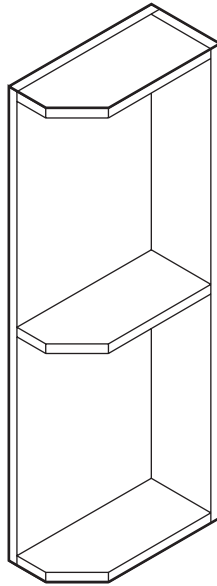

FIGURE A.48 6" WIDE WALL "WHATNOT" SHELF (WNS630R) 30" high, 6" wide whatnot shelf. Specify L or R. Right shown. (WNS636R) 36" high, 6" wide whatnot shelf. Specify L or R. Right shown. (WNS642R) 42" high, 6" wide whatnot shelf. Specify L or R. Right shown.

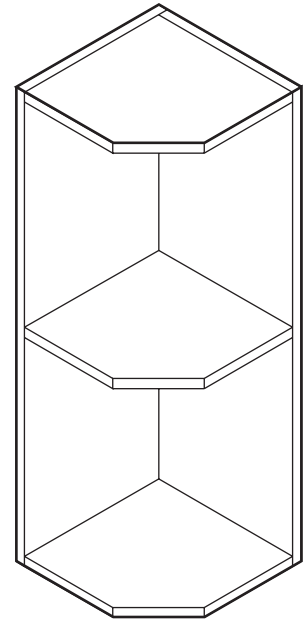

FIGURE A.49 12" WIDE WALL "WHATNOT" SHELF (WNS1230R) 30" high, 12" wide whatnot shelf. Specify L or R. Right shown. (WNS1236R) 36" high, 12" wide whatnot shelf. Specify L or R. Right shown. (WNS1242R) 42" high, 12" wide whatnot shelf. Specify L or R. Right shown.

FIGURE A.50 APPLIANCE GARAGE (CAP24) 18" high appliance storage cabinet placed below diagonal corner wall cabinets. (AP24 • AP30 • AP36) 18" high appliance storage cabinet placed below standard wall cabinets.

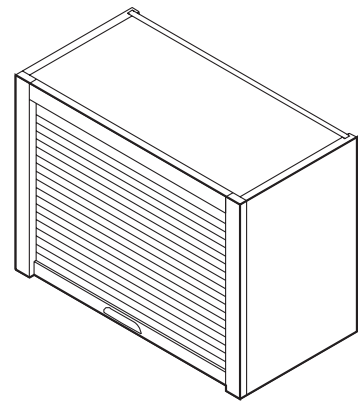
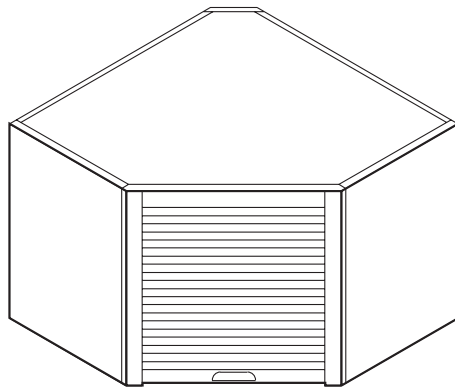
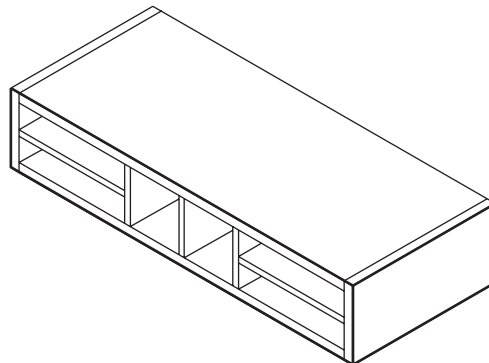

FIGURE A.51 PIGEONHOLE STORAGE (PH30 • PH36 • PH42) 6" high miscellaneous storage accessory suspended below wall cabinets.



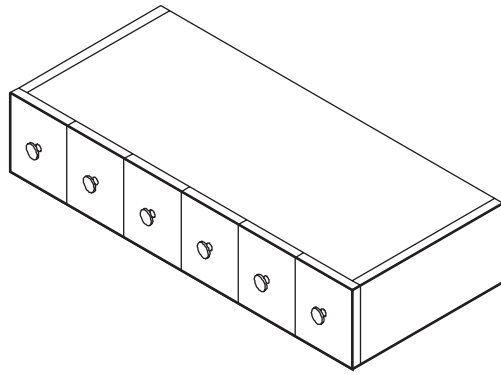

FIGURE A.52 SPICE DRAWERS (SD18 • SD24 • SD30 • SD36 • SD42) 6" high drawer storage accessory suspended below wall cabinets. Can be mounted vertically.

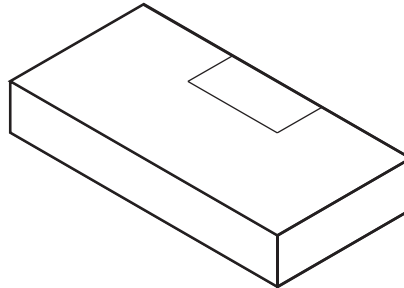
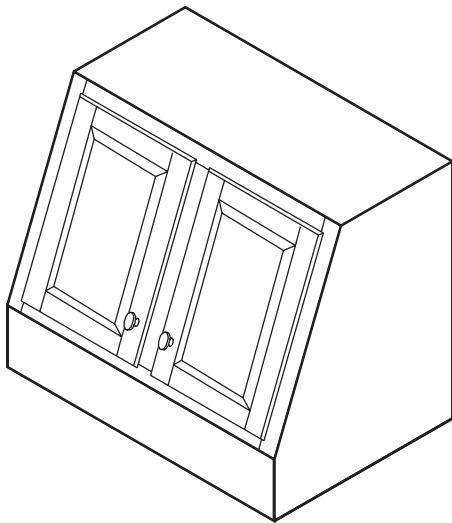

FIGURE A.53 RANGE HOOD (RH30 • RH36) 24" high wood cover for metal liner and hood assembly. Can also be combined with a light kit for a decorative, non-venting installation over a downdraft-cooking surface. Metal liner included. Order duct or ductless vent kits or light unit separately.

VALANCE BOARDS

Valance boards are placed between or under cabinets to hide light fixtures. These 4½" high boards are available in 6" increments from 24" to 96" and can be reduced in width for exact fit as needed.



FIGURE A.54 VAL-T. Traditional style shown. Reduce width at both ends equally.



FIGURE A.55 VAL-C. Contemporary style shown.

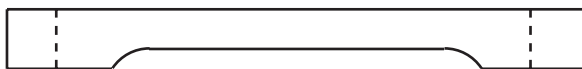

FIGURE A.56 VAL-A. Arched style shown. Reduce width at both ends equally.



FIGURE A.57 VAL-EC. English Country style shown. Reduce width at both ends equally.

GENERIC BATHROOM NOMENCLATURE

Vanity Base Cabinet Nomenclature

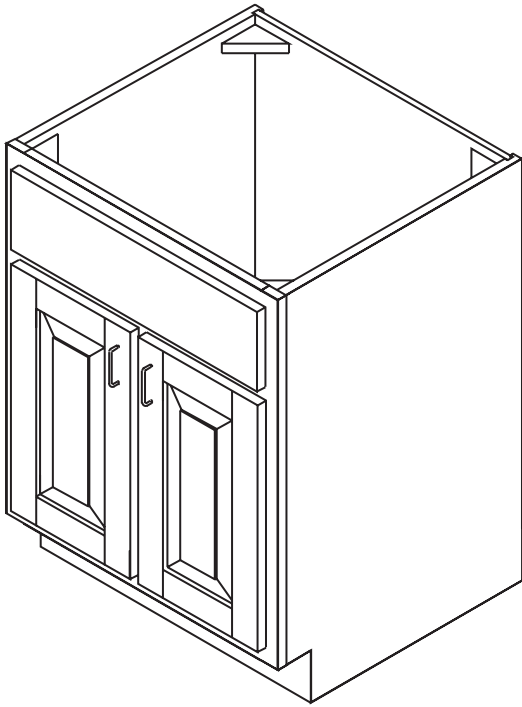

FIGURE A.58 VANITY SINK BASE (VSB24 • VSB27 • VSB30) 21" deep, 32½" high. Vanity sink base cabinet with butt-doors and ½ shelf.

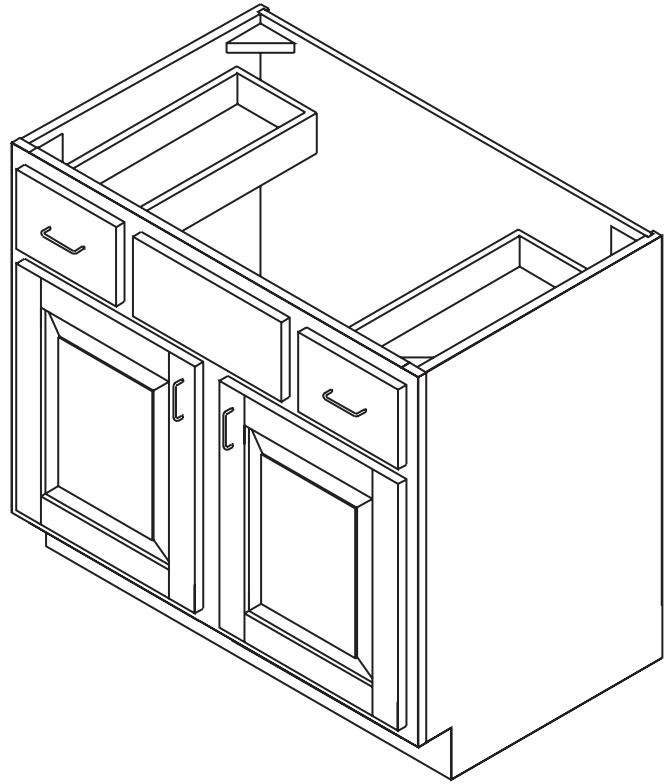

FIGURE A.59 VANITY SINK BASE (VSB36 • VSB39 • VSB42 • VSB45 • VSB48) 21" deep, 32½" high. Vanity sink base cabinet with two drawers and ½ shelf.

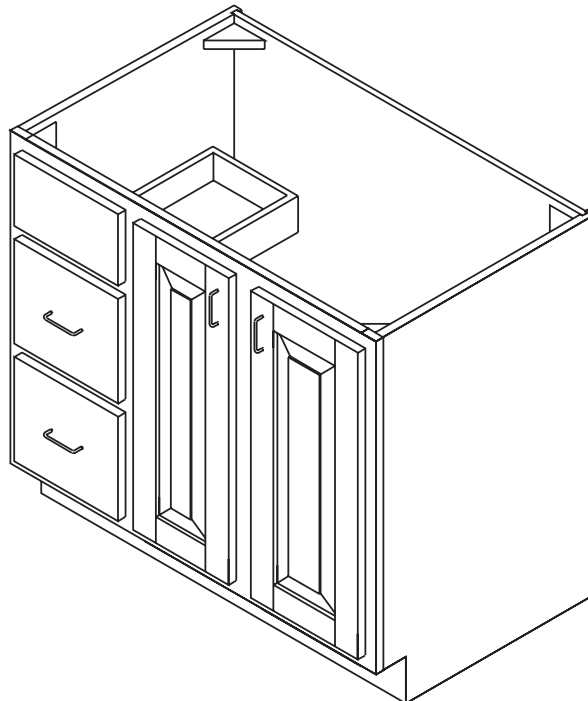

FIGURE A.60 VANITY SINK DRAWER BASE (VSDB24* • VSDB30 • VSDB36 • VSDB42 • VSDB48) 21" deep, 32½" high. Vanity sink drawer base cabinet with two drawers on one side only. Specify drawer location right or left (left shown). Full height doors.

*Butt doors.

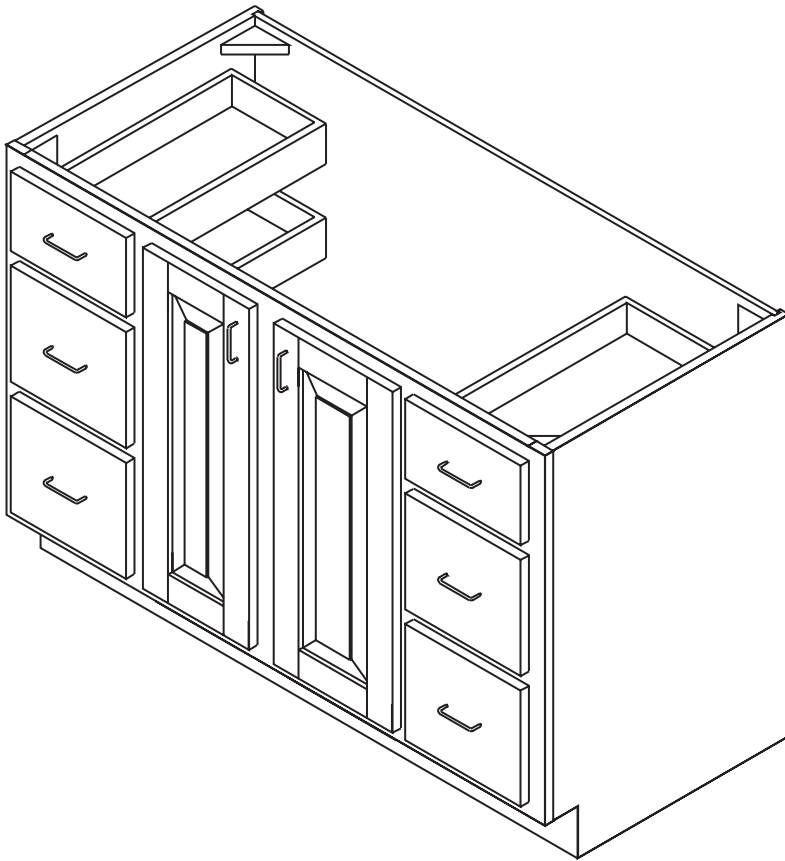

FIGURE A.61 VANITY SINK DOUBLE DRAWER BASE (VSDDB48 • VSDDB54 • VSDDB60*) 21" deep, 32½" high. Vanity sink double drawer base cabinet with three drawers on each side. *VSDDB60 is trimmable to 59" wide.

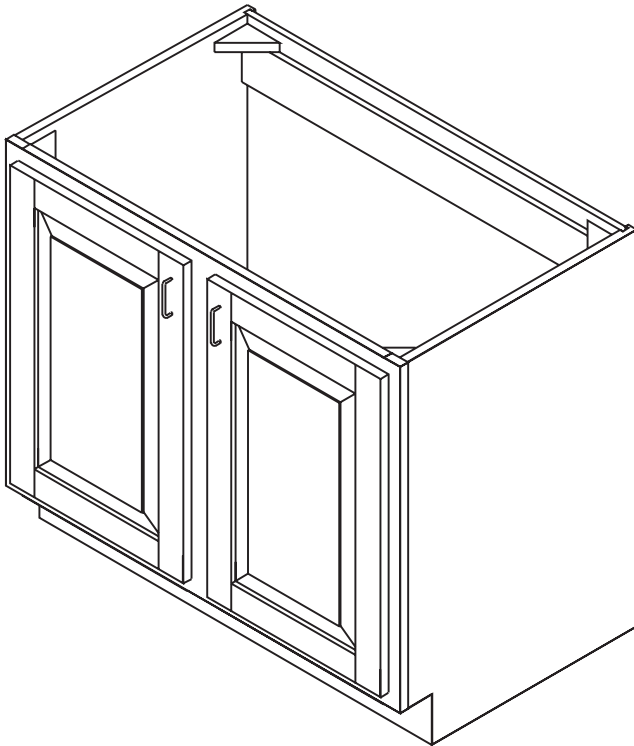

FIGURE A.62 VANITY FULL HEIGHT SINK BASE (VFHSB24* • VFHSB30* • VFHSB36 • VFHS42 • VFHS48) 21" deep, 32½" high. Vanity sink base cabinet with full height doors and ½ shelf. *Butt doors.

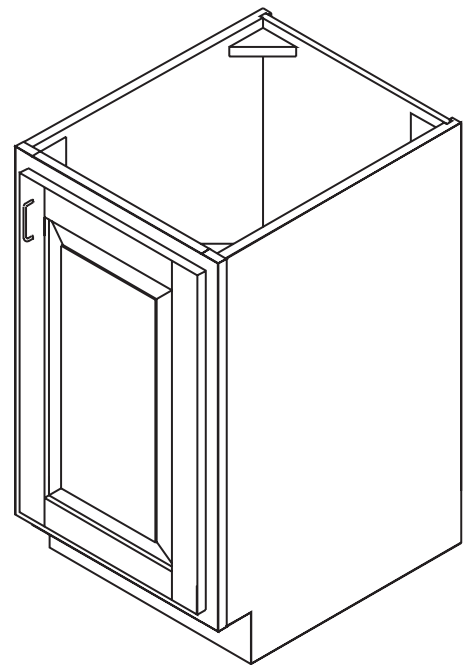

FIGURE A.63 VANITY MINI-SINK BASE (VMSB1618R) 16" deep, 32½" high. Vanity sink base cabinet with full height door. Minimal use for tight spaces. Specify hinging R or L (right shown).

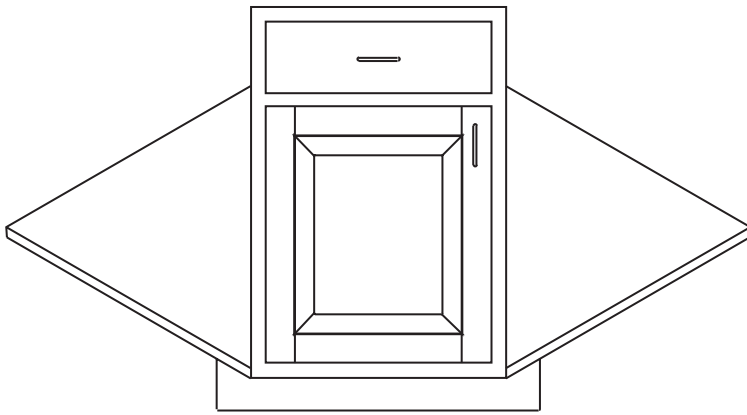

FIGURE A.64 VANITY CORNER SINK FRONT (VCSF33L) 21" deep, 32½" high. Requires 33" of wall space in each direction. Vanity Sink Front with floor. Specify hinging R or L (left shown).

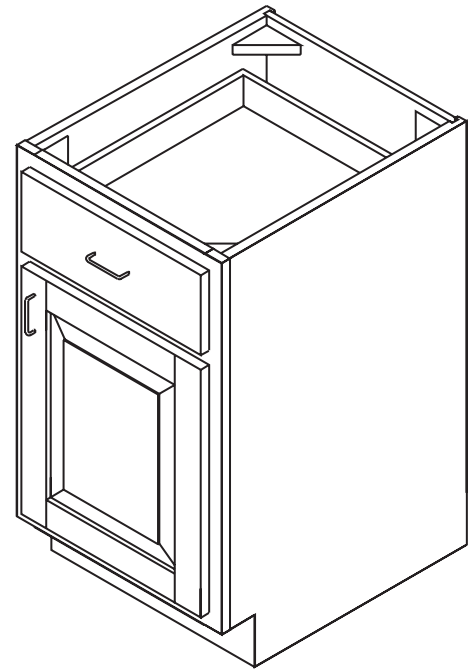

FIGURE A.65 VANITY BASE (VB12R • VB15R • VB18R • VB21R • VB24R) 21" deep, 32½" high. Base cabinet with drawer and ½ shelf. Specify hinging R or L (right shown).

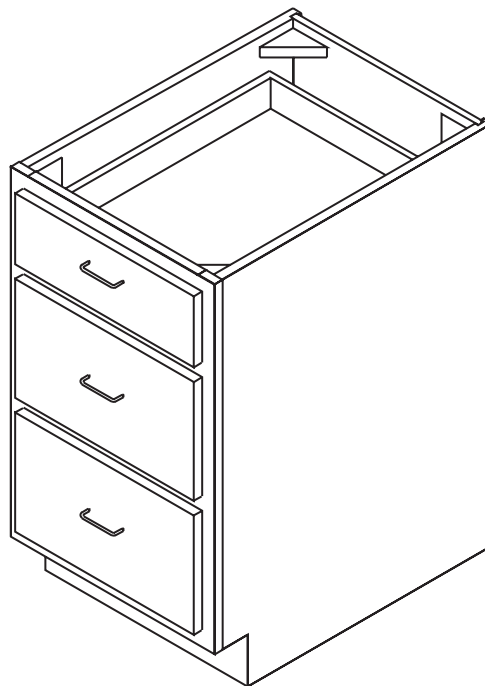

FIGURE A.66 VANITY DRAWER BASE (VDB12 • VDB15 • VDB18 • VDB21 • VDB24) 21" deep, 32½" high. Base cabinet with three drawers.

Vanity Tall Cabinet Nomenclature

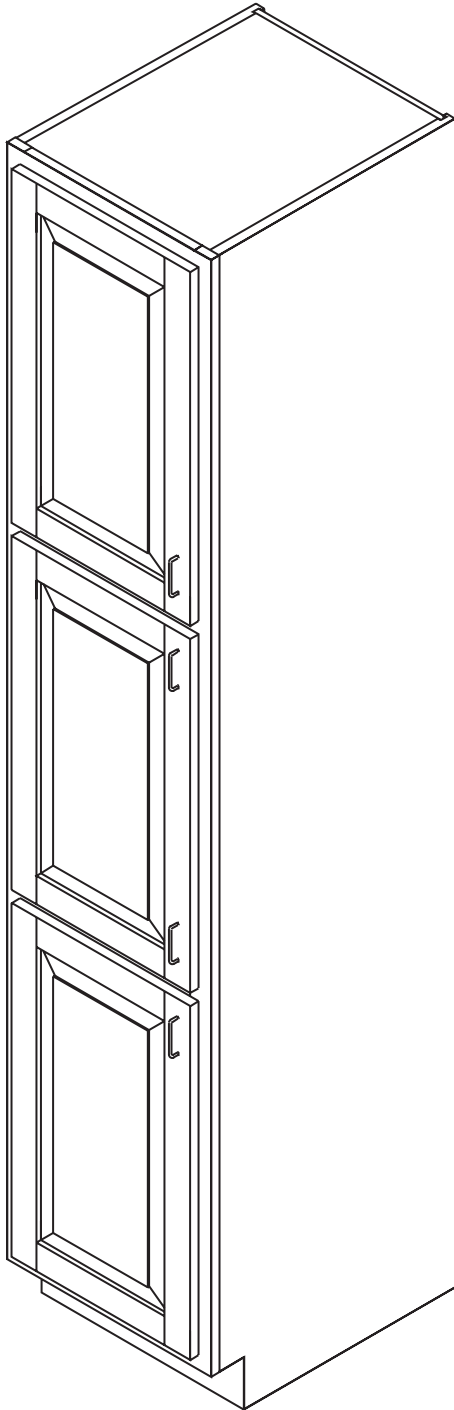

FIGURE A.67 VANITY LINEN CABINET
(VLC182184L • VLC182190L • VLC182196L)
21" deep, 84", 90" and 96" high. Tall cabinet
with three doors. Specify hinging R or L (left
shown).

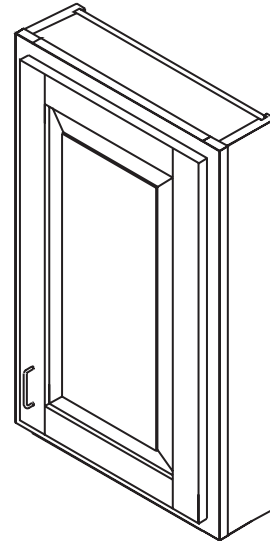

FIGURE A.68 VANITY WALL
CABINET (VWC12R
• VWC15R • VWC18R
• VWC21R • VWC24R)
5" deep, 30" high. Specify
hinging R or L (right shown).

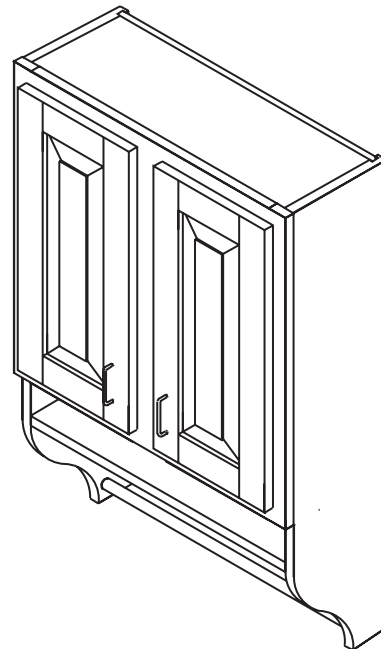

FIGURE A.69 VANITY TOILET WALL
CABINET (VTWC24) 9" deep, 30" high.

Miscellaneous Vanity Cabinet Nomenclature

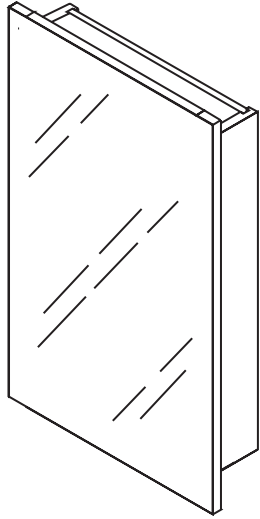

FIGURE A.70 VANITY MEDICINE CABINET (VMC16) Reversible. Can be flush mounted or installed between studs 16" on center.

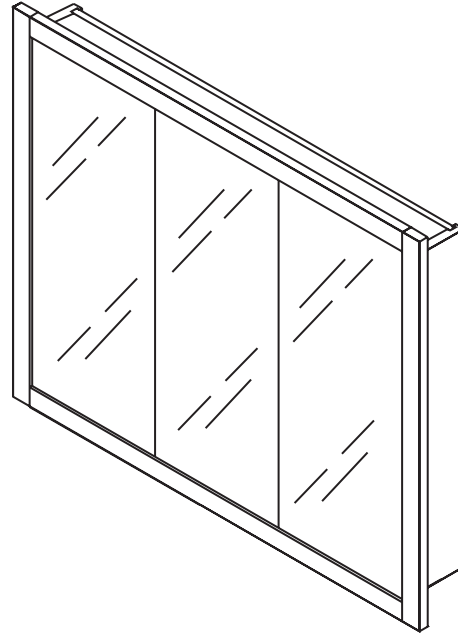

FIGURE A.71 VANITY TRI-VIEW MIRROR (VTVM24 • VTVM30 • VTVM36 • VTVM42 • VTVM48) 4" deep, 30" high. Can be flush mounted or recessed.

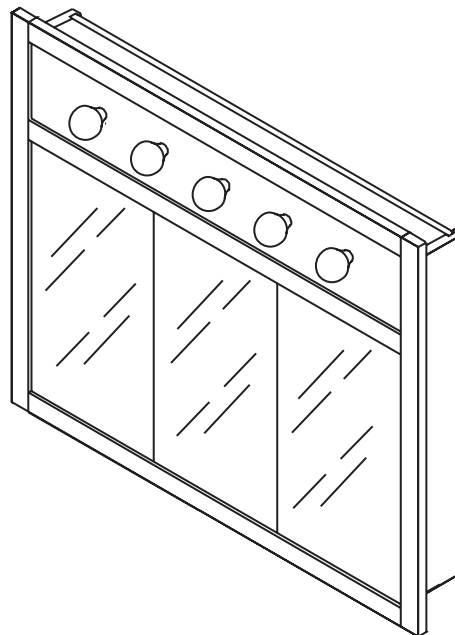

FIGURE A.72 VANITY TRI-VIEW MIRROR/LIGHT BAR (VTVMLBC24 • VTVMLBC30 • VTVMLBC36 • VTVMLBC42 • VTVMLBC48). Contemporary lighting (shown). Can be flush mounted or recessed. 4" deep, 30" high. (VTVMLBT24 • VTVMLBT30 • VTVMLBT36 • VTVMLBT42 • VTVMLBT48). Traditional lighting. Can be flush mounted or recessed. 4" deep, 30" high.

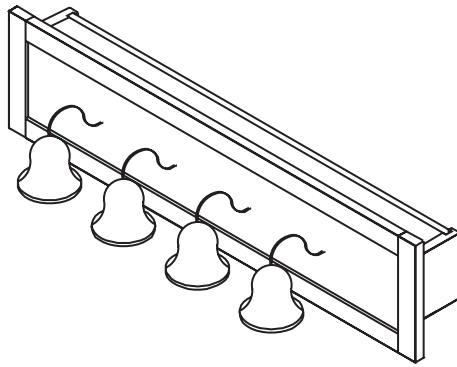

FIGURE A.73 VANITY TRADITIONAL LIGHT BAR (VLBT24 • VLBT30 • VLBT36 • VLBT42 • VLBT48). Traditional lighting. Can be flush mounted or recessed. 4" deep, 7 $\frac{3}{4}$ " high.

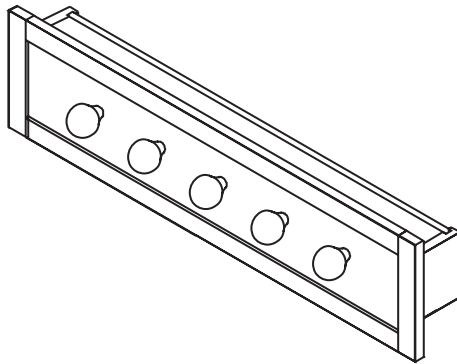

FIGURE A.74 VANITY CONTEMPORARY LIGHT BAR (VLBC24 • VLBC30 • VLBC36 • VLBC42 • VLBC48). Contemporary lighting. Can be flush mounted or recessed. 4" deep, 7 $\frac{3}{4}$ " high.

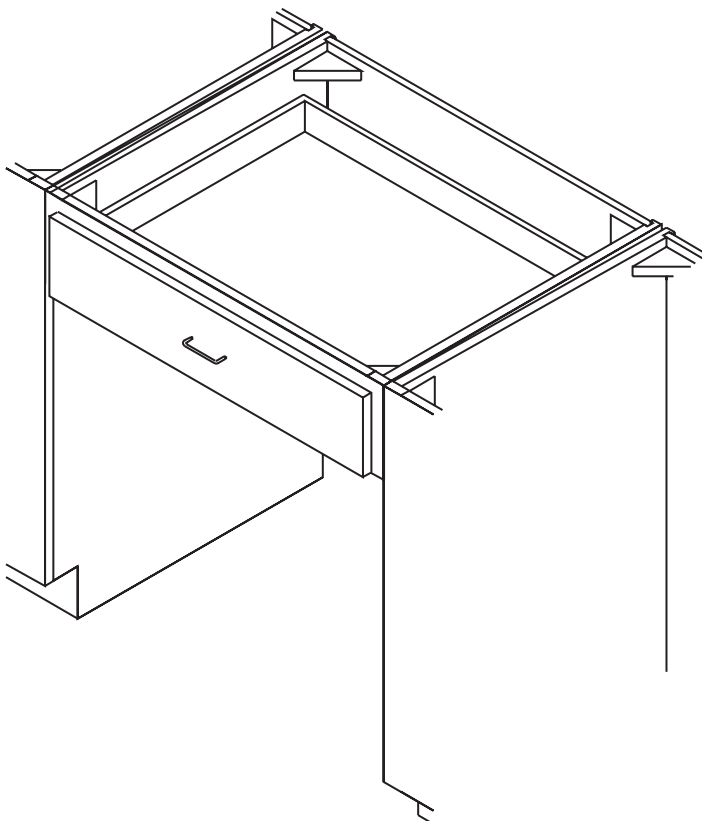

FIGURE A.75 VANITY KNEE DRAWER (VKD27 • VKD30 • VKD33) 21" deep, 6" high. All drawers are 3" trimmable in width.

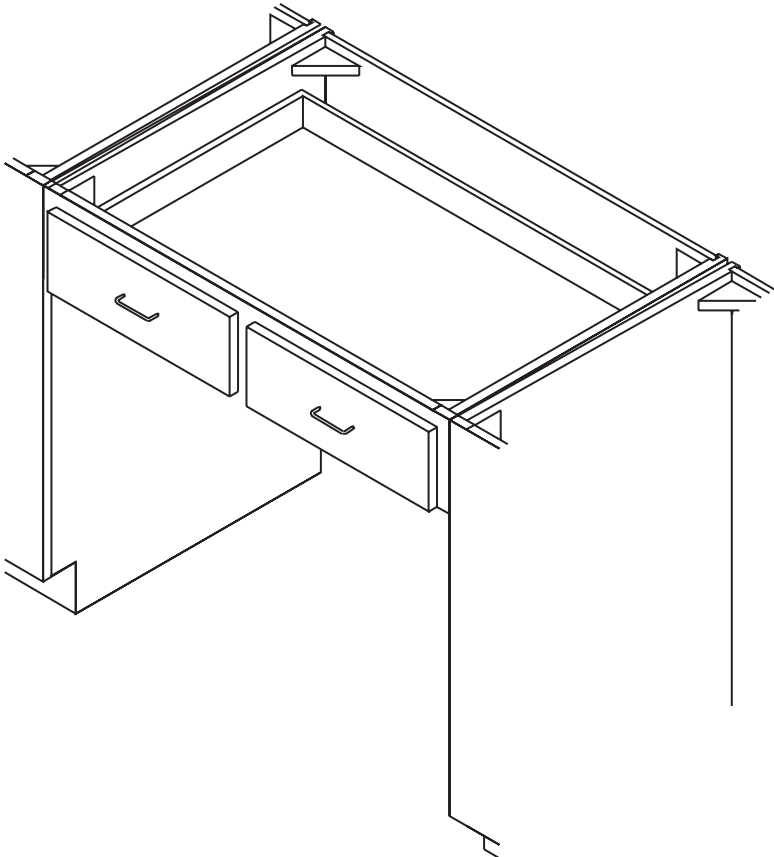

FIGURE A.76 VANITY KNEE DRAWER (VKD36) 21" deep, 6" high • Two drawers. 3" trimmable in width.

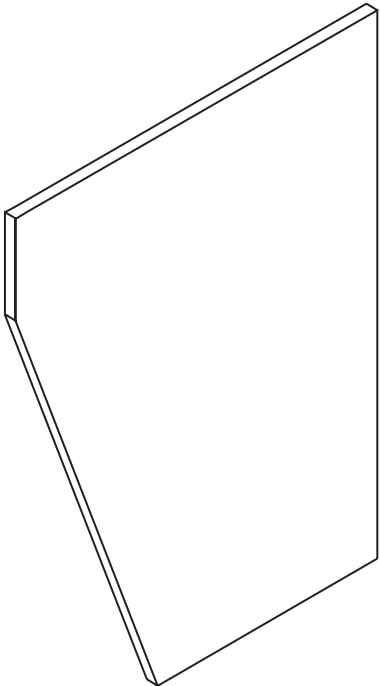

FIGURE A.77 VANITY TAPERED END PANEL (VTEP) 21" deep, (13½" at base), 32½" high.

Filler Nomenclature

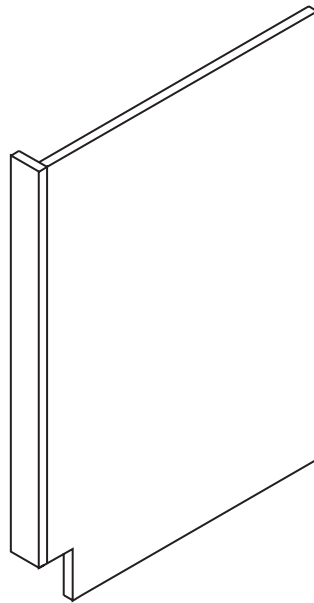

FIGURE A.78 VANITY END PANEL (VEP)
 • VEP1½ • VEP3) 21" deep,
 32½" high. Cut toe-kick on site as
 required.

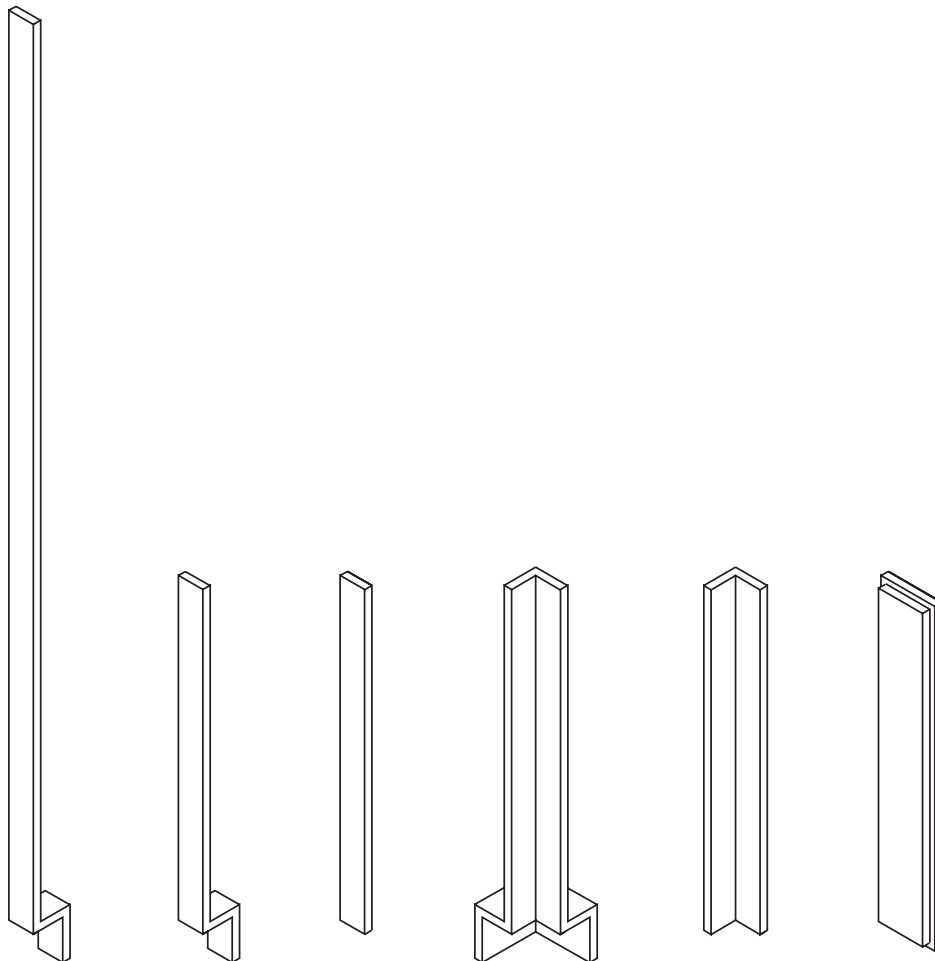

FIGURE A.79 TALL FILLERS (TF3 • TF6)
 96" high in two widths (3" and 6").
 Fillers can be cut in height and width
 for correct fit.
 VANITY BASE FILLERS (VBF3 • VBF6)
 32½" high in two widths (3" and 6").
 Fillers can be cut in height and width
 for correct fit.
 WALL FILLERS (WF3 • WF6) 30" high in
 two widths (3" and 6"). Fillers can be
 cut in height and width for correct fit.
 For taller wall fillers order TF3 or TF6.
 CORNER FILLERS (CBF3 • CWF3)
 Corner wall fillers can be cut in height.
 Both base and wall fillers can be cut in
 width.
 FILLER OVERLAYS (TFO3 • TFO6 • F03
 • BF06 • WFO3 • WFO3) Overlays are
 available for all standard fillers.
 Designed for use with full-overlay door
 styles. Specify door style to match door
 material, finish and edging profile.

FRAMELESS CABINET NOMENCLATURE—METRIC
(Courtesy of Poggenpohl)



FIGURE A.80 1 DRAWER 1 FRONT PULL-OUT WITH 1 INTERNAL DEEP DRAWER (U35 • U45 • U50 • U60 • U90)



FIGURE A.81 FRONT PULL-OUT WITH 1 INTERNAL SHALLOW DRAWER AND 1 INTERNAL DEEP DRAWER (U35 • U45 • U50 • U60 • U90)



FIGURE A.82 3 DRAWER UNIT WITH FRONT HEIGHTS: 13 cm + 26 cm + 39 cm (U35 • U45 • U50 • U60 • U80 • U90 • U100 • U120)



FIGURE A.83 4 DRAWER UNIT WITH FRONT HEIGHTS: 13 cm + 13 cm + 26 cm + 26 cm (U35 • U45 • U50 • U60 • U80 • U90 • U100 • U120)



FIGURE A.84 BASE UNIT FOR COOKTOP (UK60 • UK90 • UK100 • UK120)



FIGURE A.85 SINK BASE UNIT WITH 2 DOORS (US70 • US80 • US90 • US100 • US120)



FIGURE A.86 SINK BASE UNIT WITH 1 DEEP DRAWER AND 1 "U" SHAPE DRAWER (US60 • US90 • US100 • US120)

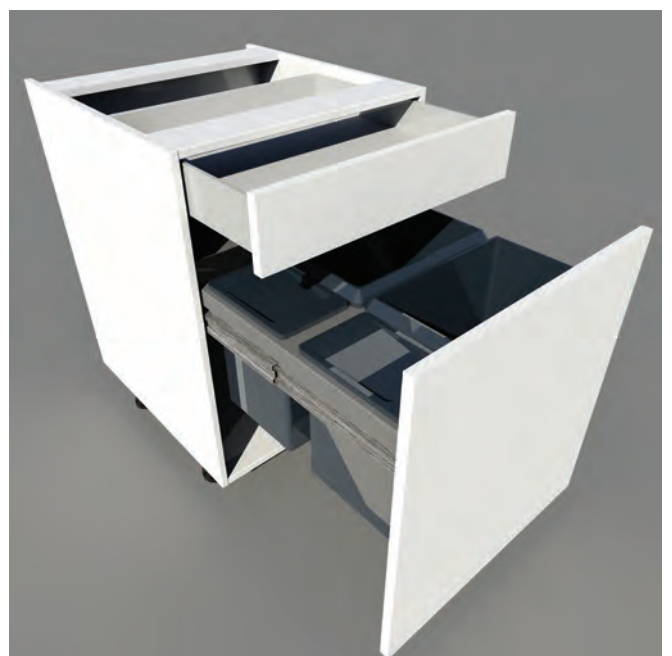

FIGURE A.87 WASTE UNIT WITH DRAWER ON TOP (U45 • U60)

Additional Frameless Cabinets



FIGURE A.88 FOLDING FLAP



FIGURE A.89 FULLY LOADED PANTRY



FIGURE A.90 HINGED 1 DOOR



FIGURE A.91 HINGED 2 DOOR



FIGURE A.92 L SHAPE CORNER



FIGURE A.93 LE MANS CORNER



FIGURE A.94 MAGIC CORNER



FIGURE A.95 PULL OUT PANTRY



FIGURE A.96 SINK 1 HINGED DOOR



FIGURE A.97 TALL APPLIANCE HOUSING



Appliance Checklist

Refrigerator Installation Considerations

- Required door swing/drawer opening dimension verified.
- Overall appliance depth (including air space and handles) listed on plans.
- Overall width, including air space and countertop overhang dimension, determined before overhead cabinet width size and height specified.
- Appliance doors drawn in an open position on the plan to verify walk-way clearances.
- Ice maker copper water lines/water filter specified.
- Trim kits and/or panels have been ordered. Labor to install has been included in estimate.
- Special handles ordered for integrated units.
- Overall height of integrated appliances with extended design cabinetry face panels engineered and appliance accessory concealment cover panels specified.

Sink Installation Considerations

- Number of sink faucet holes and fitting placement has been specified on the plans.
- Dishwasher air gap requirements have been met in design.
- Method of securing sink to counter surface has been determined:
 - Flat rim with stainless steel rim and clip installation.
 - Under-mounted sink
 - Self-rimming sink, color of caulking to be used between sink and countertop specified
 - Integral sink
- Storage planned for appliance accessories.

Dishwasher Installation Considerations

- Trim kits and/or panels have been ordered. Labor to install has been included in estimate.
- Existing water lines and drain location to be reused. New water line to be installed.
- Existing dishwasher circuit to be reused. New dishwasher circuit to be added.
- Appliance door drawn in an open position on the plan to verify walkway clearances.
- Method of securing dishwasher to underside of countertop has been determined and specified.

Trash Compactor Installation Considerations

- Trim kits and/or panels have been ordered. Labor to install has been included in estimate.
- Existing compactor wiring to be reused. New compactor wiring to be added.
- Appliance door drawn in an open position on the plan to verify walkway clearances.

Food Waste Disposer Installation Considerations

- Unit to be batch fed or switch operated .
- Switch location determined after considering primary user's handedness.
- Switch to be located on wall or countertop .
- Waste line no higher than 17 inches on center off the floor.

Drop-in or Free-standing Range Installation Considerations

- Gas or electrical requirements:
 - Gas Size of existing gas line: _____
 - Existing gas line to be reused in its existing location.
 - Existing gas line to be relocated.
 - Diameter of new gas line required: _____
 - Electric Electrical amperage of existing line: 30 amp 40 amp 50 amp
 - Electrical amperage requirement of new appliance: 30 amp 40 amp 50 amp
 - Existing electrical line to be reused in its existing location.
 - Existing electrical line to be relocated.
 - New electrical line to be added.
- Drop-in range method of support and distance from floor to bottom of range specified on plans.
- Countertop cut-out for drop-in units specified on plans.
- Side clearance for drop-in units that have a flange overlapping adjacent cabinetry has been considered in the planning process.
- Appliance overall depth, including handles, listed on the plans.
- Appliance door drawn in an open position to verify walkway clearances.

Built-in Oven Installation Considerations

- Gas or electrical requirements:
Gas: Size of existing gas line: _____
 - Existing gas line to be reused in its existing location.
 - Existing gas line to be relocated.
Diameter of new gas line required: _____
Electric: Electrical amperage of existing line: 30 amp 40 amp 50 amp
Electrical amperage requirement of new appliance: 30 amp 40 amp 50 amp
 - Existing electrical line to be reused in its existing location.
 - Existing electrical line to be relocated.
 - New electrical line to be added.
- Countertop overhang treatment against oven cabinet side to: Extend past oven case. Dies into side of special depth oven cabinet.
Case depth to be: _____
Toe kick to be: _____
- All dimensions are included in specifications and plans.
Overall appliance depth (including handles): _____
Appliance height placement in relationship to primary cook's height: _____
Cut-out and overall dimensions: _____
- For under-counter installation, manufacturer's specifications have been verified for minimum cut-out height from the floor.

Cooktop/Rangetop Installation Considerations

- Gas or electrical glass top requirements:
Gas: Size of existing gas line: _____
 - Existing gas line to be reused in its existing location.
 - Existing gas line to be relocated.
Diameter of new gas line required: _____
Electric
Electrical amperage of existing line: 30 amp 40 amp 50 amp
Electrical amperage requirement of new appliance: 30 amp 40 amp 50 amp
 - Existing electrical line to be reused in its existing location.
 - Existing electrical line to be relocated.
 - New electrical line to be added.
- Induction glass top requirements:
Electric
Electrical amperage of existing line: 30 amp 40 amp 50 amp
Electrical amperage requirement of new appliance: 40 amp 50 amp
 - Existing electrical line to be reused in its existing location.
 - Existing electrical line to be relocated.

- New electrical line to be added.
- Are there any special air flow clearance requirements for an induction top? Yes No
- Can cabinet drawers be ordered below the oven? Yes No
- Can roll-outs be installed below the cooktop? Yes No
- All dimensions (cut-out and overall) are listed on the plan. Yes No

Microwave Oven Installation Considerations

- Dedicated electrical circuit specified.
- Trim kit ordered with appliance. Labor to install trim kit included in estimate.
- Microwave oven placement is away from other heat-generating appliances.
- Appliance height has been determined in relation to the height of the primary cook for both safety and convenience.
- Cut-out and overall dimensions are listed on the plan.

Overhead Hood Ventilation Considerations (Disregard if duct-free ventilation system specified)

- Ducting goes through the wall to the exterior, and the vent cap terminates on the exterior wall.
 - Ductwork location lands between the studs or requires reframing of the exterior load-bearing wall
 - Can the exterior finish material be matched/repaired/replaced? Yes No
 - Will the cooking residue being vented to the exterior affect the exterior finish material? Yes No
 - Are there any covenants or restrictions that may restrict or eliminate venting through an exterior wall? Yes No
- Ducting is on the interior of the kitchen and goes through the ceiling to terminate on the roof.
 - Ductwork will land between the floor/ceiling joists or requires reframing of the floor or roof structure
 - Will the ductwork be enclosed by a vent cover that matches the hood vent, cabinetry, or drywall? Yes No
 - Does the ductwork go through an upper cabinet? Yes No
 - Can the cabinet be modified for a duct chase? Yes No
 - Will additional cabinet material for a duct cover be ordered and the cabinet modified on site? Yes No
- Is there an option for an in-line vent motor? Yes No
 - Where can it be accessed? _____
 - Is there enough space for it to be accessed? Yes No
 - Can power be brought to that location? Yes No
- Is there an option for a roof-mount vent motor? Yes No
 - What is the roofing material? _____
 - Will it accommodate/allow for installation? Yes No

- Hood depth in relation to adjacent cabinetry: _____
- Hood distance from cooking surface: _____
- Hood width in relationship to cooktop width below: _____

Downdraft/Proximity Ventilation Considerations (Disregard if duct-free ventilation system specified)

- Ducting goes directly through the back of the cabinet to the exterior wall, and the vent cap terminates on the exterior wall.
 - Ductwork location lands between the studs or requires reframing of the exterior load-bearing wall .
 - Can the exterior finish material be matched/repaired/replaced? Yes No
 - Will the cooking residue being vented to the exterior affect the exterior finish material? Yes No
 - Are there any covenants or restrictions that may restrict or eliminate venting through an exterior wall? Yes No
- Ducting goes directly through the floor to the exterior wall, and the vent cap terminates on the exterior wall.
 - Ductwork will run between the floor joists to the exterior wall or requires reframing of the floor structure .
 - Is there access below the floor joists (crawl space) for the ductwork to run with minimal turns to the exterior wall? Yes No
 - Is there finished living space below the kitchen? Yes No
 - Will the ceiling need to be repaired to accommodate the downdraft system? Yes No

Cabinet Modification Considerations for Downdraft Ventilation

- Design solution requires a deeper cabinet (26–27 inches for the downdraft unit installation? (Include additional cabinet material and labor to trim the interior of the cabinet after the downdraft unit has been installed.)
- Floor is concrete slab construction.
 - Vent the downdraft out the back of the cabinet and through an exterior side wall.
 - If code permits, consider a duct-free appliance.

Duct Path Installation Considerations

- Size of duct piping required: _____
- Length of duct path from ventilation system to exterior termination point: _____
- Number of elbow turns along duct path: _____ Space between the elbow turns: _____
- Ventilating unit's (free air pressure) CFM rating: _____
- Is a make-up air system required by your building/HVAC codes? Yes No

Glossary

A

Acrylic finish

A protective coating that is sprayed on a smooth substrate, then sanded and buffed to create either a flat matte or high-gloss finish.

Accessible bathtub

A bathtub having either a hinged door or a door that raises and lowers, allowing the bather to enter the bathtub, close the door, and then fill the bathtub with water.

Actuator

A mechanical device for moving or controlling something, such as a toilet tank lever or push button.

Aerator

A device attached to the end of a faucet that mixes air into flowing water.

Air gap

Device mounted at the back of a kitchen sink, connecting to the drain line between a dishwasher and disposer to allow the dishwasher to discharge freely into the disposer while preventing contaminated water from siphoning back into the dishwasher.

Alkyd

A type of synthetic resin used in paint.

ANSI

Abbreviation for American National Standards Institute, a private nonprofit organization that oversees the development of voluntary consensus standards for products, services, processes, systems, and personnel in the United States.

Apron panel sink

Specially designed sink featuring an exposed or decorative front apron.

Architectural grade

A grade of wood veneer. Utilizes top quality veneer and generally has special requirements for balancing, sequencing, component width, etc.

Aromatherapy

A form of alternative medicine that uses volatile liquid plant materials, known as essential oils (EOs), and other scented compounds from plants for the purpose of affecting a person's mood or health.

B

Backsplash

A vertical waterproof surface that protects the area above a cooking surface, sink or bath from splashes.

Bamboo flooring

Bamboo is a renewable grass product. The product used to make floors is up to 12" in diameter and 30' high. After harvesting, a 4' stump remains which regenerates in 5 years. The product comes in tongue-and-groove boards that can be glued or nailed.

Baseboard

A narrow board, attached to the base of an interior wall, that covers the joint between the wall and the floor.

Bathtub, accessible

Bathtubs having either a hinged door, or a door that raises and lowers, allowing the bather to enter the bathtub, close the

door behind them, and then fill the bathtub with water.

Bathtub, apron

A decorating portion of a bathtub that covers the rough-in area from the floor to the top rim of the tub.

Bathtub, free-standing

Fixtures that can be placed along a wall, at right angles with a wall, or placed in the center of a room.

Bathtub, platform

A bathtub with no finished panels. Designed to drop into a platform made of another material.

Bathtub, recessed (alcove)

A bathtub without finished ends and with one finished side, typically called the apron. Designed to slip between two end walls and against a back wall.

Bespoke kitchen

A set of cabinets made specifically for one client or one project.

Bidet

A personal hygiene plumbing fixture similar in appearance to a toilet bowl used for washing genitals and posterior areas of the body. Mounted on the floor, it consists of a washing basin, a hot and cold faucet, and sprayer/jets.

Bio-based architectural panels

Nonstructural panels made of recycled wheat stalks milled into fine particles, sorted and dried, and then bound together with a formaldehyde-free resin. Also referred to as wheatboard or agri board.

Bird's-eye

The term given to the small to large eye-shape markings found randomly throughout select sheets of maple.

Blind cabinet

A cabinet that has a shelf, pull-out, or swing-out apparatus to provide accessibility into the corner.

Blowout (compression)

A toilet flushing action that relies entirely on the driving force of a jet action. Because of the water capacity required to accomplish this, blowout designs are used in tankless installations only, in combination with a flush valve.

Bracket (corbel)

A support projecting from a wall to support a shelf or some ornamental feature, such as mantel hoods, countertop overhangs, and decorative shelves.

Btu

Abbreviation for British thermal unit. A Btu is the amount of heat energy needed to raise the temperature of 1 pound of water by 1° F. This is the standard measurement used to state the amount of energy that a fuel has as well as the amount of output of any heat-generating device.

Bulkhead

See "Soffit."

Bump-out

See "Soffit."

Burl

A type of wood veneer. A swirling grain around clusters of dormant buds, rings, or eyes. Available in white ash, olive ash, Carpathian elm, maple, mappa, myrtle, and walnut.

Burner

A circular ring or plate on a gas or electric range that produces heat or a flame.

Burnished glazing

A type of wood glaze in which color is applied over all surfaces and wiped off, leaving residue in all crevices and shaped elements. Also called a penetrating glaze, referring to the way color penetrates into the pores of the wood, allowing it to contribute to the finished color of the wood.

Butt joint

The junction between two ends of timber/members that meet in a square-cut joint.

Butt joint drawer system

A system securing the individual pieces of component parts together without an interlocking joint.

C**Cable drain**

A drain system in which a cable runs outside the system and connects the handle of the overflow to a plug-lift mechanism just below the outlet's flange.

Canopy ventilation

A type of ventilation in which airborne vapors rise naturally into a capture area of the canopy. The internal blower then pulls the vapors from the capture area and exhausts the air to the outside.

Cast iron

A manufacturing process used to produce bathtubs and kitchen sinks; molten iron is cast in a sand mold. Sand is used to shape the cavity of the mold.

Cast polymer

Surfaces created by pouring a mixture of ground minerals and polyester resin into a treated mold, where the curing process takes place at room temperature or in a curing oven. Used for bathtub fixtures, one-piece shower enclosures, three- to four-piece shower enclosures, and vanity surfaces, often with an integrated lavatory.

Catalytic (continuous cleaning) system

An oven-cleaning system in which a catalytic material is mixed into the porcelain enamel coating on the oven liner panels. This material causes a chemical reaction at normal cooking temperatures that oxidizes food soils continuously as they occur during the cooking operation. This method does not require a separate cleaning cycle at high temperatures because the cleaning takes place simultaneously as the food is cooked. Compare to **Pyrolytic (self-cleaning) system**.

Ceramic tile

A natural material composed of clays, shales, porcelain, or baked earth. These raw products are pressed or extruded into

shapes and then fired in a kiln, baked in an oven, or cured in the sun.

CFM

Abbreviation for cubic feet per minute. This is a measurement of air volume velocity and is often used in measuring air flow from heating or cooling diffusers. It is a rating based on fan size.

Chatoyance

A term used to describe the iridescence of some veneer finishes. Created by the finishing process, which enhances the shimmer resulting when light reflects off of the wood fibers at different angles. Also called *moire* or *vibrance*.

Chromatherapy

Sometimes called color therapy or colorology, it is an alternative medicine method. Chromatherapy uses the visible color spectrum. These colors, with their unique wavelength and oscillations, are selectively applied to impaired organs or body systems with a light source to provide the healing energy.

Cleanup center

Area of the kitchen primarily housing the food waste disposal and dishwasher.

Color washing

A decorative paint technique that creates visual texture by layering paint colors. Sometimes referred to as a modern-day fresco technique.

Column

A pillar, usually round, that acts as a support or decorative feature for a structure above.

Combination valve

Combination pressure balancing and thermostatic valve control. This system compensates for both temperature and pressure fluctuations of supply inlets.

Combing

A decorative painting technique that involves applying a base-coat paint, covering it with a glaze of a complementary or contrasting color, and then pulling the teeth of the rubber combing tool through the glaze to reveal the base coat.

Composite panel

A layer of decorative paper impregnated with either melamine resin or polyester resin, which is thermal-set or thermal-fused

(fused with heat and pressure) to a substrate of particleboard, fiberboard, or some other material. It is sold as laminate board. Composite panels are used in vertical or light-use horizontal applications, such as shelving. They should not be used for countertops.

Composite wood

A range of derivative wood products manufactured by binding or fixing the strands, particles, fibers, or veneers or boards of wood, together with adhesives, or other methods of fixation to form composite materials.

Compression valve

A type of valve often used for water faucets. It is opened or closed by raising or lowering a horizontal disk by a threaded stem.

Compressor

A motor and pump sealed inside a steel case concealed within the refrigerator structure. The pump compresses refrigerant vapor that concentrates the heat and sends it to the condenser.

Concrete countertop

Concrete is a specialized countertop surfacing material. Molded into shape, it is seamless. Concrete can also be dyed just about any color. Concrete countertops can be fabricated at the manufacturing facility or poured in place. Because it begins in the form of a slurry, concrete can be transformed into virtually any shape that becomes a solid mass. It can be polished, stamped, or stained. Objects can be embedded in it.

Condenser

A long folded tube that receives hot, high-pressure refrigerant vapor pumped by the refrigerator compressor. As the heat leaves, the vapor inside the tube cools and condenses back to liquid.

Conduction

A process by which heat is transferred through a substance or from one substance to another that is in direct contact with it by molecular activity.

Console table lavatory

A separate or integral fixture that is installed above, below, or integrated into a countertop material that is supported by decorative legs, resembling a console

piece of furniture. Plumbing lines are partially concealed by the front edge of the console furniture piece.

Continuous cleaning system

See **Catalytic (continuous cleaning) system**

Convection

A process of heat transfer involving the motion of heated matter itself from one place to another. This transference of heat appears in both liquid currents and in air currents.

Conventional mortar bed (mud)

An installation method where tile is installed on a bed of mortar, either while the mortar bed is still soft or after the tile is set on a cured mortar bed.

Cooking center

The area in the kitchen which includes all equipment used to transfer heat for the preparation of foodstuff (the oven, cooktop, range, etc.).

Cooktop

A self-contained surface cooking unit that drops into a cut-out in a countertop.

Core material

The primary material from which an object, such as a cabinet door, is made.

Cork

A product made from the bark of special oak trees grown primarily in Spain and Portugal. Produced by a renewable process whereby 6 to 9 inches of bark is cut from the trunk, leaving the tree alive and intact. It takes five to seven years for the bark to grow back after harvesting.

Countertop lavatory

A separate fixture installed above or below the level of the countertop material. Plumbing lines are concealed in the cabinetry.

Crackle (crackling)

A type of finish reminiscent of common finish deterioration seen in porcelain (a very small crackle application) or weather deterioration of a furniture finish caused when the finish dries and cracks due to exposure to heat.

Crazing

Tiny fractures or hairline cracks within a surfacing material (e.g., gel coat or concrete).

Crotch

Veneer cut from the juncture of a tree's main branches and trunk where the tree has forked in two directions. Crotch figures are often subcategorized as flame, plume, rooster tail, feather, or burning bush.

Curb shower

A shower with a raised edge or border separating the shower base from the balance of the shower floor.

Curbless shower

A shower with no curb. The shower pan must be lower than the bathroom floor, allowing it to slope to the center or to a rear or side wall of the enclosure.

Curly maple

A grade of maple veneer with a distinctive wide band or curl figure throughout. Also known as flame veneer. Curly maple veneer with a tight figure is sometimes referred to as a fiddleback.

Custom cabinetry

Totally custom *built-to-order* cabinets. Considered furniture-grade systems. Not produced until a space has been designed and all details are finalized.

Custom-made kitchen

A set of cabinets made specifically for one client or one project.

D

Dado

A rectangular groove along the width of a board.

Distressed wood finishes

Wood finishes that simulate an antique appearance in furniture, paneling, trim, and accent pieces. This rustic finish softens the look of new wood, creating a finish with a vintage appearance.

Distressing

The deliberate damaging of a wood finish to create the appearance of aged furniture.

Dovetail joint

A joinery technique commonly used to join pieces where high tensile strength is called for. The joint is created by cutting a triangular-shape tenon in one piece and the corresponding mortise in the other.

Dowel

A short, round wooden stick with ends cut flat. In cabinet construction, dowels are used primarily to reinforce the corners.

Dragging

A technique that creates a directional pattern by dragging or coasting a dry brush through wet paint or glaze.

Drawer cabinet

A cabinet featuring two, three, four, or five drawers.

Drop-in range

An appliance installed between base cabinets and supported by the countertop deck and by adjacent cabinetry. There is a rim to provide the transition from range to countertop.

Dry glazing

Glazing technique in which material with an almost chalk-like consistency is applied after burnishing with a glancing stroke; appears on lead raised edges. Identified as defining glazing, which means the wood grooves are highlighted by the glaze.

Drywall

Also known as plasterboard, wallboard, or gypsum board, or by the brand names Sheetrock or Gyprock. A panel made of gypsum plaster pressed between two thick sheets of paper. It is used to make interior walls and ceilings.

Duct-free downdraft ventilation

A HAPA (high-airflow particulate air) filter captures smoke, grease, and moisture while allowing air to travel through the filter without loss of efficiency. The clean air is vented through the cabinet toe-kick space back into the room. The filter has an indicator light alerting the user when it needs to be replaced.

E**Edgebanding**

Used in carpentry and furniture making to cover the exposed sides of materials such as plywood, particleboard, or MDF. Edgebanding can also be used instead of features such as face frames and molding.

Electric conventional coil elements

With conventional coils, electrical resistance is used to create heat for cooking. Wire is encased in a metallic tube filled

with an insulation material. The tube is shaped into a coil and flattened for maximum contact with cooking utensils. Heat travels from the hot coils to the cookware both by conduction (where there is contact) and radiation.

Electric glass ceramic cooktop

A cooktop with electric resistance coils located under a smooth glass ceramic top. The heat radiates to the glass surface, where it is transferred to the pot by conduction and some radiation.

Electronic mixing valve

A valve that acts as an electronic thermostatic valve, maintaining the temperature that has been programmed in by the user.

Enameled steel

Used for bathtubs and lavatories, this material is fabricated by forming steel in a cold state, then applying coating of enamel, and finally firing the finished piece in an oven.

End panel

The exposed side of a cabinet, vanity, or furniture piece.

Ethylene gas

A colorless, flammable gas that occurs naturally in certain plants and can be obtained from petroleum and natural gas. As a plant hormone, it ripens and colors fruit, and it is manufactured for use in agriculture to speed these processes.

Evaporator

A long tube that receives liquid refrigerant from the refrigerator condenser. The liquid boils and vaporizes as it picks up heat from inside the cabinet.

F**Face**

1. Leaves of veneer that have been spliced together but have not yet been applied to a panel or backer sheet. 2. The better side of any plywood panel in which the outer piles are of different veneer grades.

Face frame

In cabinet making, a frame fixed to the front of a cabinet carcass. The face frame obscures the edges of the carcass and provides the fixing point for doors and other external hardware. A face frame provides strength to the front of a cabinet.

Faucet

A fixture for drawing or regulating the flow of liquid, especially from a pipe. See also individual faucet types.

Faux finish

The art of creating illusions with paint. With combinations of colors, finishes, tools, and techniques, painters—or talented homeowners—create unique effects for wall and ceiling surfaces.

Fiberboard

A building material made of wood or other plant fibers compressed and cemented into rigid sheets.

Fiberglass

Fixtures that are generally referred to as fiberglass refer to the backing material used to reinforce a polyester gel coat finishing surface. A mold receives a layer of gel coat, and then fiberglass strands immersed in a polyester resin is sprayed on or placed on top of the mold in mat form.

Fiddleback

Narrow bands of figure that run uninterrupted from edge to edge across the width of the veneer leaf. When book matched, a chevron pattern is formed. Most commonly available in anigre, maple, makore, and English sycamore.

Figure

The pattern produced in a wood surface by annual growth rings, rays, knots, deviations from natural grain such as interlocked and wavy grain, and irregular coloration.

Finial

A decoration or embellishment at the top of something, such as the top of a hinge.

Fire clay

A compound ceramic material that includes prefired clay particles mixed with ball and china clays. The prefired clay particles (called grog) are ground into small grains and added to the liquid casting slip, giving it a distinct appearance.

Fitted kitchen

A set of cabinets sized and scribed to the room, allowing the cabinetry to become part of the woodwork of the house.

Fitting

A faucet, bathtub filler spout, showerhead, body spray, body mist or other

finished piece through which water passes and then enters a fixture.

Fixture

A kitchen sink, bathtub, shower, lavatory (bathroom sink), toilet (water closet), bidet, or urinal that receives water.

Flagstone

Flagging is a process whereby stone is split into thin slabs suitable for paving. Although generally identified as flagstone, bluestone and slate are the most common types of flagging stones used.

Flake

Figures created when the pithrays are cut across at an angle when slicing. Vary in size from dash marks to stretch marks. Very common in quartered red and white oak.

Flange

Extending rim or edge at one end of a pipe shaft that gives support or a finished appearance.

Flares

Markings across the grain of the face of the wood. In book-matched material, the markings seem to extend across the width of the face.

Flat cut (plain slicing)

A type of veneer cut. A log is cut in half lengthwise, then placed on the slicer where the knife cuts individual leaves of veneer parallel to the original cut. Flat cutting produces a cathedral or loop grain effect in the center of the leaf and straighter grain along the edges.

Flat veneer and laminate door

A door style using flat shaped pieces of lumber, plywood, or engineered board substrate. Edges may be finished in PVC edge tape to blend with the doors, a finger-joined wood veneer edge tape, or a solid wood edging.

Flitch

The complete bundle of thin sheets of veneer after cutting, laid together in sequence as they were sliced or sawn. A log cut lengthwise from a tree, ready for further processing.

Fluorescent lamp

A gas-filled glass tube with a phosphor coating on the inside. Gas inside the tube

is ionized by electricity, which causes the phosphor coating to glow. Normally two pins extend from each end of the lamp.

Flush-mounted sink

A sink that is recessed into the countertop substrate material so it is even with the counter material.

Food preservation center

Area of the kitchen housing the refrigerator, freezer, and other types of chilling appliances.

Food waste disposer

A device that shreds food waste products into pieces small enough to pass through plumbing. Eliminates concerns with odors and rodent/insect problems associated with garbage placed in regular trash receptacles.

Formaldehyde

A colorless, pungent-smelling, irritating gas used chiefly in aqueous solution as a disinfectant and preservative and in chemical synthesis.

Frame cabinet construction

A type of cabinet construction in which component parts make up the sides, back, top, and bottom of a cabinet. These parts are joined together and attached to the face frame, which is the primary support for the cabinet. Doors and drawers are fit in one of three ways: flush with the frame, partially overlaying the frame, or completely overlaying the frame.

Frameless cabinet construction

In this type of cabinet construction, the case parts form a box that does not need a front frame for stability or squareness. Doors and drawers cover the entire face of the cabinet.

Freestanding

General term for any fixture, cabinet, or appliance that can be placed along a wall, at right angles with a wall, or placed in the center of a room; compare to "built-in."

G

Garage cabinet

A cabinet with a roll-up door (called tambour) that extends to the countertop. Most commonly used to store small appliances.

Gel coat

A surfacing process that begins by spraying a gel coat onto a mold. Because most residential fixtures are sprayed by hand, the gel coat thickness ranges from 12 to 20 mil (1 mil = 1/1000th of an inch). Thicker gel coats that are applied unevenly lead to a common problem associated with cast polymer fixtures called crazing.

Glass blocks

Translucent hollow blocks that transmit light yet provide privacy. When used in exterior wall installations, they deaden outside noise and offer insulating qualities similar to thermal-pane windows. Available in a variety of shapes, sizes, textures, and colors.

Glass tile

Tiles made from glass. Available in textures from mirror-slick to rough, and in a variety of colors from deep and muted to multicolored with iridescent options. Glass tiles are available in clear glass or with a backing finish designed to camouflage the rough wall surface.

Glazed tile

A type of tile with a coating of glass-forming minerals and ceramic stains (the glaze). The glaze is sprayed onto the body of the tile (known as the bisque) before firing. The type of glaze used often determines the recommended end use of the tile (i.e., walls, floors, and counters).

Glazing

The application of a colored material after the base coat of stain or paint has been applied.

GPF

Abbreviation for gallons per flush. Refers to the amount of water a toilet uses for the flushing of waste in a single flush.

GPM

Abbreviation for gallons per minute. The rate of flow by which faucets and showerheads are measured and regulated.

Grain

The direction, size, arrangement, and appearance of the fibers in wood or veneer.

Granite

A very hard natural igneous rock. Granite begins as the liquid magma (hot molten stone) in the center of the earth. Due to extreme pressure within the earth and the absence of atmosphere, granite is formed very dense. It is really a host of ingredients, including common minerals like feldspar, quartz, and mica. Feldspar is the major mineral component of granite, comprising 60 to 80 percent of the stone.

Granite composite sink

A sink fabricated with up to 85 percent natural granite particulates. Available only in matte finishes.

Graywater

A term used to describe the waste water from sinks, showers, and baths, that is used for a variety of purposes, including landscape irrigation and toilet flushing.

Green

A generic term used to describe any product or action meant to help the environment.

Grout

A thin mortar used to fill gaps, especially between tiles. There are different types of grout for different types of tiles, with different properties and characteristics.

H**Halogen burner**

A halogen burner works like an incandescent light bulb. Electricity passes through a tungsten filament inside a quartz-glass tube. Resistance causes the filament to heat up, and in the process, tungsten particles boil off. Therefore, conventional electric energy is converted into light and heat beneath the glass ceramic surface.

Halogen lamp

A gas-filled tungsten filament incandescent lamp with a lamp envelope made of quartz to withstand the high temperature. This lamp contains some halogens (namely iodine, chlorine, bromine, and fluorine), which slow the evaporation of the tungsten. Also called a quartz lamp.

HAPA filter

Abbreviation for high-airflow particulate air filter. Not to be confused with a HEPA (high-efficiency particulate absorption) filter.

HAPs

Abbreviation for hazardous air pollutants.

Hardwood

General term used to designate lumber or veneer produced from deciduous or leaf-bearing trees, such as oak or maple.

Heartwood

The nonactive center of a tree generally distinguishable from the outer portion (sapwood) by its darker color.

Hot-stamped transfer foils

Hot-stamped transfer foils (HSTF) are laminated by the continuous hot-roll method. HSTF is basically paint or ink reverse printed on a Mylar carrier foil, with an adhesive top coat. Heat and pressure activate the top coat and deposit the ink or paint, and the Mylar is peeled away. Most often used on the edges and profiles of cabinetry.

Hybrid frame/face frame cabinet construction

A system of construction allowing the manufacturer to utilize the engineering method of frameless construction for the case while creating the look of handcrafted joinery by adding a nonfunctional face frame to the front exterior of the cabinet. In this method of construction, the width of the face frame (less the thickness of the side material) extends beyond the case side, resulting in a void space between each cabinet.

Hydrotherapy

Hydrotherapy, or water therapy, is the use of water (hot, cold, steam, or ice) to relieve discomfort and promote physical well-being.

I**Imperial sizing**

Units of measure based on inches. Used by U.S. manufacturing companies.

Incandescent lamp

A lamp employing an electrically charged metal filament that glows when heated by the electric current.

Induction

An electronic cooktop heating system. An induction system has powerful, high-frequency electromagnetic elements under the unit's ceramic surface. When cook-

ware made of magnetic material—such as a cast iron skillet or stainless steel pot—is placed on the element's magnetic field, the field transfers (induces) energy into the metal. The magnetic current causes the molecules of the metal cookware to vibrate at high frequencies, creating friction that heats the cooking vessel.

Injection molding

A method of manufacturing plastic fixtures. The plastic material is heated until it reaches a liquid state, at which time it is injected into the cavity of a mold. With this process, the color you see on the surface goes all the way through the material.

Integral sink

A type of sink in which sink and countertop are all made out of one piece of the same material.

J**Joint**

Any meeting of two surfaces. In veneer, the line between the edges of two adjacent leaves of veneer.

K**Knot**

Cross section of a tree branch or limb with the grain usually running at right angles to that of the piece of wood in which it occurs. Knots may be *open*, produced when a portion of the wood substance of a knot has dropped out, or *tight*, solid across their face and fixed by growth to retain their place.

L**Lacquer**

A finish that has generally replaced varnish and shellac. Lacquer offers a hard, durable, water-resistant surface. For proper application, it is sprayed on a smooth substrate, then sanded and buffed to create either a flat matte or high-gloss finish. Lacquer is mirror smooth and transparent, enhances the colors over which it is laid, and brings out the beauty of the wood grain.

Laminate

The technique of manufacturing a material in multiple layers, so that the composite

material achieves improved strength, stability, sound insulation, appearance, or other properties from the use of differing materials. A laminate is usually permanently assembled by heat, pressure, welding, or adhesives.

Laminate flooring

Laminate flooring consists of several layers of material bonded together under high pressure, similar to the laminate products used for countertops. A clear melamine top layer protects the design layer. Next is a plastic resin-impregnated paper layer with a wood grain pattern. These are bonded to a structural fiberboard core, backed by a layer of melamine. The clear topmost wear layer is smooth and can be slippery when wet, making laminate flooring a questionable option for baths.

Lap joint

A joint made by overlapping two ends or edges and fastening them together.

Lavatory

A fixed bowl or basin in the bathroom with running water and drainage for washing.

Lazy Susan cabinet

A cabinet containing a round shelf that swings out into the room and past the door opening.

Leaf (Leaves)

Sliced sheet of a veneer flitch.

LCD

Abbreviation for liquid-crystal display. A flat-panel display, electronic visual display, or video display that uses the light-modulating properties of liquid crystals.

LED

Abbreviation for light-emitting diode. An LED produces light when electrons move from a positive force to a negative force within its semiconductor structure.

Limestone

A sedimentary rock, created by millions of years of seashells and bones of sea creatures settling as the sediment on an ocean floor. The calcium in the bones and shells combines with the carbon dioxide in the water to form calcium carbonate, which is the basic mineral structure of all limestone and marble. Used

for floors, backsplash areas, and bathroom surfaces.

Log

The section of a tree that can be sawn or used for veneer.

Louver

An opening with a series of horizontal slats arranged to permit ventilation but to exclude rain, sunlight, or viewing into.

M

Make-up air

The volume of air required to replace air exhausted from a given space.

Marble

Metamorphosed limestone. Marble and limestone begin as the same material. Given enough heat and pressure, limestone will crystallize, resulting in marble. The crystal structure allows marble to take a polish that brings out the color of the other trace elements.

Mastic (organic) adhesive

An installation method wherein tile is directly applied to the countertop, decking, or cement surface with troweled-on mastic, a pasty cement that is used as an adhesive.

Medium-density fiberboard (MDF)

An engineered wood product formed by breaking down hardwood or softwood residuals into wood fibers, often in a defibrator, combining it with wax and a resin binder, and forming panels by applying high temperature and pressure.

Metal drawer system

Totally integrated drawer system featuring a stainless steel, aluminum extruded, or other metal-type three-side drawer system. The drawer bottom repeats the material selected for the case interior. These three-sided drawer component systems then connect directly to the drawer head.

Metric sizing

Units of measure based on millimeters or centimeters. Used by international manufacturing companies.

Microwave

Microwave energy is a form of nonionizing radiation. Nonionizing radiation

(infrared, microwaves, broadcasting waves) in sufficient intensity will cause a rise in temperature but will not cause cell changes. Microwaves vibrate millions of times per second and are very short waves, hence the term "microwave." Microwave-powered ovens cook food by activating the dipolar (water) molecules so they rotate in a rapidly alternating electrical field.

Millwork

Wood architectural elements (such as doors, sashes, trim, or molding) manufactured at a woodworking mill.

Millwork cabinetry

Produced just as custom cabinets are by a millwork company. Sometimes used as an identifier for the most custom of cabinet manufacturing processes.

Miter-framed drawer system

A four-sided miter-framed low-pressure melamine drawer system, or a boxed melamine drawer system. Miter-framed drawer systems score the core material of the drawer, then the sections of the drawer are folded together to form the box.

Mixing valve

A type of plumbing valve that mixes hot and cold water to achieve a specified delivery temperature.

Molding (Moulding)

A decorative strip of wood or another material used to decorate or finish a surface of a wall or a piece of furniture. Molding may be *curved*, with classical shapes, such as a crown molding, or with carved details in form of flowers, leaves, or stylized patterns. Sometimes spelled *moulding*.

Mortar

A mixture of sand, water, and cement or lime that becomes hard like stone.

Mortise-and-tenon

A type of joint used in woodworking; a slot (the mortise) is cut into a board, plank, or timber, usually edgewise. The mortise receives a projecting part, or tenon, of another board, plank, or timber to form a joint. Many years ago mortise-and-tenon joints were used in house building. Today they are mainly used in assembling cabinets.

Mosaic tile

Mosaic tiles are distinguished from other kinds of tile by their small size, which must not exceed 6 square inches (2.45 by 2.45 inches if square shaped). The most common types are natural clay and porcelain in which the color is throughout the tile rather than being applied on the surface like a glaze. However, glazes may be applied as well.

Mottle

A term used to describe a variegated or block pattern figure. The grain lines are broken and irregular, which differentiates the figure from curly.

Mullion/Muntin

A vertical post or other upright that divides a window or other opening into two or more panes. Sometimes only ornamental.

N**Nomenclature**

A term used to identify an alphabetical and numerical proprietary system used to label pre-engineered cabinet sizes.

O**Oil finish**

A type of wood finish, most satisfactory on hard or close-grained woods. When this finish is properly applied, the wood is impervious to water, heat, scratches, and most stains.

Old growth

A term referring to large trees that have grown in natural forests.

One-off kitchen

A set of cabinets made specifically for one client or one project.

P**Penetrating wood sealer and penetrating resin-oil**

Types of wood finishes; they withstand stains, water marks, minor burns, and scratches. They are of two general types, one containing wax and the other varnish. The finish coating wax will give a soft sheen rather than a high gloss. Thin, medium, and heavy consistencies are available.

Paint-dragging

A decorative painting technique. White or off-white paint is left in cabinet joints and within distressed sections.

Paint, eggshell

Provides a low-luster sheen. This is a very good choice if the wall surface is not perfectly smooth.

Paint, flat

Provides a desirable low-glare surface for walls and ceilings that do not need frequent washing.

Paint, high gloss

The most wear-resistant and moisture-resistant finish because of its relatively high proportion of resin. The more resin, the heavier and tougher the film. The high-resin film of the glossy paints makes them ideal for areas subject to heavy use and frequent washing. However, the high sheen also makes any wall surface or finish imperfections very noticeable.

Paint, semigloss or satin

Affords moderate durability with a less obtrusive shine. Popular choice for most woodwork.

Patting glazing

Glazing applied on white wood edging after wear, before finish, with pat-pat-pat-sponge rhythm.

Particleboard

An engineered wood product manufactured from wood chips, sawmill shavings, or even sawdust, and a synthetic resin or other suitable binder, which is pressed and extruded. Particleboard is a composite material.

Parquet flooring

Simulated 12- by 12-inch tiles or actual individual pieces of wood, it is interlocking and blind-nailed.

Pedestal lavatory

A one-piece unit that stands on its own. It has little or no countertop surface. The water supply lines are visible.

Peninsula cabinet

A wall cabinet that is accessible from two sides and is installed above a cabinet that juts out into the center of the room.

Perimetric ventilation

A ventilation system that pulls airborne particulates through narrow slots along the edge (the perimeter) of a center panel into an enclosed space. An internal blower then exhausts them to the outside.

Pickling

A type of wood finish in which white pigment is rubbed into wood to enhance the grain. Pie-cut cabinet

A corner cabinet that features stationary shelving, as opposed to a rotating shelf.

Plank flooring

Interlocking flooring that is blind-nailed. Generally, random lengths of 9 to 96 inches are used as well as random widths.

Platform bathtub

A bathtub with no finished panels. Designed to drop into a platform made of another material.

Plinth

The lowest member of a base of an object.

Plywood

A board made by gluing and compressing thin layers of wood together with the grain of each layer at right angles to the layer next to it

Polyester finish

Polyester is sprayed on a smooth substrate, then sanded and buffed to create either a flat matte or high-gloss finish.

Polyurethane (Urethane)

A polymer composed of a chain of organic units joined by carbamate (urethane) links. Polyurethane is used as a surface coating and a surface sealant as well as in high-performance adhesives. It can be applied over bare wood, sealer, or a varnish finish.

Point-of-use appliance

Smaller versions of typical appliances or custom-designed units for specific food/drink products. The majority of these appliances, such as a refrigerated drawer, are designed to slip underneath a normal countertop.

Pommel  (Pom-el-ay)

A dense pattern in wood consisting of small rings enveloping one another. Often described as looking like the surface of a

puddle during a light rain or resembling suede or fur. Most commonly available as sapele.

Pop-up drain

A type of drain assembly for lavatory and bath. When a lavatory lift rod or bath overflow plate lever is lifted, the pop-up drain closes so the lavatory or tub retains water.

Pressure-balancing valve

A shower mixing valve that automatically maintains balance between incoming hot and cold water supplies by immediately regulating fluctuations in pressure. As a result, temperature remains constant, though the outlet pressure may drop. Also called an anti-scald valve.

Proximity ventilation

A ventilation system located near the cooking surface. It can be integral to the cooking surface or a separate appliance placed behind the cooking surface. Proximity ventilation captures the vapors in the zone around the cooking surface and vents them to the exterior of the house or through a filtered system and then back into the room.

PSI

Abbreviation for pounds per square inch. Refers to a unit of pressure from the imperial system.

Pyrolytic (self-cleaning) system

An oven cleaning system. In this system, the oven is heated at temperatures ranging from 850° F (454.44° C) to 1000° F (537.78° C). (*Pyrolysis* is a chemical change brought about by the action of heat.) At the end of the completed cycle, after the cool-down period, all that remains of the food soil is a powdery ash that is easily removed with a damp cloth. Compare to **Catalytic (continuous-cleaning) system**.

Q

Quarter cut

A type of lumber; a quartered section of log is placed on the slicer, and the knife cuts individual leaves of veneer at a 90-degree angle to the growth rings. Quarter cutting produces a striped effect, straight in some species and varied in others.

Quartz composite

Quartz composite (also known as engineered stone) is comprised of 93 percent quartz and 7 percent polymers, pigments, and binder. Since composites are man-made, they do not have the variations in color and texture of granite or marble. Because they are nonporous, they do not have to be sealed.

Quarry tile

Tile made from shale, clays, or earth extruded to produce an unglazed product that has color throughout the tile body. There are a variety of quality levels within the broad term "quarry tile."

R

Rabbit cut

A recess or groove cut into the edge of a piece of machineable material, usually wood. When viewed in cross section, a rabbit is two-sided and open to the edge or end of the surface into which it is cut.

Recessed (alcove) bathtub

A bathtub without finished ends and with one finished side, typically called the apron. Designed to slip between two end walls and against a back wall.

Radiation (heating method)

Heat transfers by conduction and convection in cookery on top of the range. Radiation of heat takes place at the speed of light (186,300 miles per second) in electromagnetic waves. No material medium is required for its transmission.

Rail

A cross member of a panel door or a frame cabinet face.

Range top

A front-controlled cooking unit, which requires a lowered cabinet height to accommodate the front panel controls.

Reconstituted wood

Real woods that have been reglued, resliced, and dyed to mimic more valuable woods. They are created by gluing together natural veneers in special presses and reslicing to get certain predetermined effects.

Recycled glass

Manufactured from waste glass. Used as a surfacing material, this is glass manufactured with tempered glass, post-consumer

waste glass, and semiprecious man-made stones.

Refrigerator enclosure

The appliance box, made of various materials designed to create an inner and outer shell with insulation between.

Recycling cabinet

Specialized cabinet designed to hold bins to facilitate the separation of refuse for recycling.

Resin-impregnated foil

An alpha-cellulose paper impregnated with urea, acrylic, or melamine resins. Sometimes called paper or melamine paper. In Europe, it is called foil.

Rift cut

A method of sawing lumber. To avoid the bold flake effect of cutting oak on the true quarter, a quartered section of log is placed on a rotary slicer and veneer is cut at an angle, about 15% off the quartered position. Rift cutting produces a rift or comb grain effect. Typically, oak is rift cut.

Rimmed sink

A sink that sits slightly above the countertop with the joint between the sink and the countertop concealed by a metal rim.

Rotary cut

Another method of sawing lumber, in a rotary cut a full log is placed in the lathe and turned against a razor-sharp blade that peels a continuous sheet of veneer along the annular growth rings. Rotary-cut veneer is exceptionally wide and produces bold, variegated grain markings.

Rough-in

To lay out the basic plumbing lines without making the final connections.

Running bond pattern

A pattern of laying tile. Tiles are laid end to end, with joints that land in the middle of the tiles in adjacent rows; or tiles are laid end to end, with joints that land at a one-third or two-third point in each adjacent row.

S

Sauna

An invigorating bath originating in Finland in which steam is provided by water thrown on hot stones. The bather sits on

wooden benches in a room typically lined with wood.

Scribing

A technique for cutting and fitting woodwork/cabinetry to an irregular surface.

Self-cleaning system

See **Pyrolytic (self-cleaning) system**.

Selective harvesting

A practice of periodically removing mature trees in order to allow young trees to grow.

Self-rimming sink

Sink sits on top of the countertop. A hole is cut in the surface and the fixture is dropped in by the installers. A bead of caulking is applied between the sink and countertop, forming a seal.

Semi-custom cabinetry

Cabinetry produced on an assembly-line basis but offering more interior fittings in the form of accessories and some custom cabinet size possibilities.

Sensing technology

A type of faucet technology that allows the faucet to be activated when the user's hands are placed underneath the spout or as the individual approaches the fixture, delivering water at a certain temperature and volume. Also called "touchless" technology.

Shower pan

In a shower compartment or stall, a waterproof pan with sides above the finish floor level, in which the floor drain is located.

Shower tower

A preengineered, predesigned unit that includes several showerheads.

Single-hole faucet

A faucet with a single-handle control requiring only one hole in the countertop for mounting. The water filler and the control mechanism are designed to function within this configuration.

Siphon jet

A toilet flushing action where the jets deliver flow with such a volume as to begin the siphoning action instantly, without any rise in the level of water in the bowl before the contents are drawn through the outlet.

Siphon vortex

A toilet flushing action based on diagonal rim outlets that cause a swirling or whirlpool action. The resulting rapid filling of the trap triggers the siphoning of the bowl contents.

Siphon wash

A toilet flushing action that relies entirely on the incoming rush of water from the rim. The resulting rapid filling of the trap triggers the siphoning of the bowl contents.

Slate

A metamorphic rock, with layered characteristics, formed from the low-grade metamorphism of the sedimentary rock shale. Fine-grained of mostly microscopic quartz and calcite. Can also contain some of the same minerals found in granite, which makes some slate iridescent and/or hard. Like limestone and marble, the colors come from trace metals. Slate is durable and acid and stain resistant.

Soapstone

Also known as steatite or soaprock, soapstone is a talc-schist, which is a type of metamorphic rock. Largely composed of mineral talc and rich in magnesium. It is used for both interior and exterior design elements.

Soffit (Bump-out, bulkhead)

An industry word identifying a boxed-in area above the cabinets. The proper construction term would be "bulkhead," made up of fascia (the front panel) and the soffit (the underside). However, it is typical in the industry to call the entire structure a soffit.

Softwood

Wood from trees classified as gymnosperm, primarily coniferous trees, such as pine, fir, or cedar.

Solid surfacing

A material manufactured from acrylic, polyester, or a combination of acrylic and polyester base materials. These homogeneous (color all the way through) materials can be machined by a skilled fabricator and are repairable if damaged. The hard, nonporous surfaces are stain and burn resistant.

Sone

An internationally recognized unit of loudness, which simplifies reporting of

sound output. The sones translate laboratory decimal readings into numbers that correspond to the way people sense loudness.

Sous-vide

French term meaning "under vacuum." Sous-vide is a method of cooking food sealed in airtight plastic bags in a water bath for longer than normal cooking times—72 hours in some cases.

Spatter/cowtailing

A type of decorative wood finish in which lacquer is sprayed across the finish in a random fine pattern to add depth to the finish. Spatter can be large and watery, small pinpoint black, or light/dark brown. Small wisps of accent paints may also be applied.

Special-purpose sink

Specially designed sinks in a variety of shapes and sizes appropriate for second or third sink centers such as next to a stove with pot filler faucet feature.

Specifications (Specs)

A narrative list of materials, methods, model numbers, colors, allowances, and other details that supplements the information contained in the blueprints. Specs provide written elaboration in specific detail about construction materials and methods. They are written to supplement working drawings.

Sponging and rag rolling

A multicolored/layered faux finish is created by dabbing color on with a rag, roller, or sponge.

Spot ventilation

A ventilation system in which an exhaust appliance is placed above a cooking appliance, behind it, or as an integral part of the cooking surface. The system's internal (or externally located) fan must effectively capture a column of air containing vapors, steam, and smoke directly over or around the cooking surface and exhaust them to the outside of the home or scrub them through a filter system.

Stain. See Wood stain

Stainless steel

Generally formed following the same process described for enameled steel fixtures. However, no surface coating is applied to a stainless steel fixture.

Steam shower

An enclosure that is usually equipped with special plumbing to create steam. The enclosure itself either runs from the floor to the ceiling or has a top (transom panel) to contain the steam.

Stile

Vertical flanking members on a panel door or a frame cabinet face to which the horizontal top and bottom rails are secured.

Stippling

A painting technique that transforms a flat surface into a finely grained finish, adding dimension to the wall surface.

Stock cabinetry

A full range of cabinets in specified sizes, door styles, finishes, and accessories with limited modifications.

Storage zone(s)

Separate storage areas in the kitchen divided by function. A kitchen may have storage zones for cooking, cleaning, food preparation, consumables, such as food, and nonconsumables, such as dishes, cutlery, glassware, and the like.

Striated glazing

A faux finish technique. The consistency of the glazing is such that brushstrokes leave a striped pattern in both a horizontal and vertical direction.

Strip flooring

Butt flooring that is top-nailed. All boards are the same width (2 and 2¼ inches) and random lengths.

Subbase

Underlying support placed below what is normally construed as a base.

Substrate

The base material on top of which other material is installed.

Surfacing material

Materials specified for the floors, walls and wall surrounds, countertop areas, and backsplash verticals of a space.

Sustainable forestry

Practices that ensure the resources removed from the forest are at a level the forest is capable of renewing without damaging its future prosperity.

T**Telescoping downdraft ventilation**

A type of proximity ventilation system located behind the cooking surface that extends up when in use.

Temperature-limiting valve

A valve with a high-temperature limit stop that is adjustable. The high-temperature limit stop prevents scalding by limiting the temperature of the water that can pass through the valve.

Tempered glass

A type of safety glass. The tempering process strengthens the glass and changes the way in which it breaks. The resulting properties make the glass safer upon breaking and ideal for any glass object that needs to break in a safe manner. Glass can be tempered in different ways and to varying strengths.

Terrazzo

A combination of marble, concrete, and cement that can be formed into a variety of configurations, such as a countertop with an integral sink. This marble aggregate concrete produces a hard and durable flooring surface. It is also used as a wall treatment.

Thermally fused melamine (TFM)

Melamine-impregnated papers that can be fused to a substrate by heat and pressure. Also known as low-pressure laminate (LPL), low-pressure melamine, melamine component panels (MCP), or just melamine.

Thermostatic valve

Pressure-balancing shower mixing valve with automatic temperature control. When temperature or pressure fluctuations occur at the water inlets, a thermal actuator adjusts the hot and cold ratio to maintain the original temperature setting.

Thermotherapy

The use of heat to alleviate pain and stiffness, especially in joints and muscles, and to increase circulation.

Thinset over backerboard

A tile installation method where mesh concrete backerboard may take the place of a conventional mortar board.

Three-hole faucet

A faucet with hot and cold handles separate from the spout. It requires three holes for mounting. A variation is called a bridge faucet, which has a horizontal connector (bridge) joining hot and cold water sources. The bridge is a prominent design feature above the countertop or the deck.

Threshold

The material placed at a doorway when the finished flooring of an adjacent room is higher. Generally made of marble or wood.

Toe kick

An indentation designed into the bottom of a cabinet to provide room to allow the user to stand closer to the countertop.

Touch control faucet

A touch-control faucet is activated when the human body comes in contact with any part of the spout or handle of the faucet when it is in an open position. The contact creates an electromagnetic pulse that sends a signal to the solenoid-activated valve installed underneath the sink along the faucet piping.

Trapway

The channel in a toilet that connects the bowl to the waste outlet. The trapway is where siphonic action occurs, and its size is measured in terms of the largest ball that can pass through it.

Trash compactor

A waste disposal system that compacts mixed refuse. The compactor plugs into a standard household circuit and is operated by a motor. The motor drives a single ram down that compacts the trash.

Travertine

Travertine is a form of limestone formed from geothermal springs and is characterized by pitted holes and troughs. It is one of the most frequently used stones in modern architecture.

Trim

The material used to finish off and cover joints of a surface installation (e.g., flooring, window and door openings, countertops).

Trip-lever drain

A drain with a lever that opens and closes the drain on the bathtub waste and overflow.

Trompe l'oeil

A French term that means “fool the eye.” Often used to describe a mural with a three-dimensional appearance on a residential flat wall surface. It typically refers to a painted scene that fools the eye into looking like something with depth and distance.

Two-hole faucet

A faucet requiring two holes in the countertop for mounting; the water spout occupies one hole, the single water volume/temperature control occupies the second hole.

U**Underlayment**

A material placed under a decorative surface (e.g., hardware flooring) to provide a suitable installation surface.

Under-mounted sink

A sink installed underneath the countertop.

Unfitted kitchen

A set of cabinets that are not scribed to the walls, ceiling, or floor of the room. Although they are secured to the wall for stability, they appear more like furniture than casework.

Urinal

A receptacle that is attached to a wall and plumbed in, used by men.

V**Vanity**

Bathroom storage cabinet located under the sink.

Varnish

A type of wood finish. Available in all gloss finishes. Provides a finish that is resistant to water, alcohol, and other liquids. Most varnishes today are made of synthetic resins, which dry fairly rapidly to form a hard surface coating that is exceptionally resistant to rough wear.

Veneer

(1) Thin layer as surface: A thin layer of a material bonded to the surface of a less attractive or inferior material; (2) layer of plywood: A thin layer of wood that is glued together with others to make plywood; (3) outer layer: An outer layer applied to a surface for decoration or protection.

Ventilation, mantel or chimney hood

A ventilator housed in a custom enclosure, which acts as a focal point in the space.

Venturi effect

A phenomenon that occurs when a fluid that is flowing through a pipe is forced through a narrow section, resulting in a pressure decrease and a velocity increase. Named after Italian physicist Giovanni Battista Venturi (1746–1822).

Vinyl film

Heat-laminated adhesive backed films that simulate a variety of finishes such as wood, granite, marble, and so on. .

Vinyl sheet flooring

Flooring available as inlaid (the pattern going throughout the wear layer of vinyl) and as rotogravure (the pattern is printed on a sheet). Both are then covered with a layer of wearing surface.

Vinyl tile flooring

Solid or pure vinyl tiles that are homogeneous vinyl and are unbacked and usually of uniform composition throughout. Can be installed on suspended wood subfloors or over on-grade and below-grade concrete.

Vitreous china

A type of china used in the manufacture of lavatories, toilets, bidets, and urinals. It is composed of ceramic materials fired to form a nonporous body, having exposed surfaces coated with a ceramic glaze fused to the body. Vitreous china has less than ½ of 1 percent moisture absorption compared to other types of ceramics, such as wall tile, which may have as much as 10 percent moisture absorption.

Volatile organic compounds (VOCs)

Organic chemicals that have a high vapor pressure at ordinary room temperature. Their high vapor pressure results from a low boiling point, which causes large numbers of molecules to evaporate or sublime from the liquid or solid form of the compound and enter the surrounding air.

W**Wainscoting**

General term for the material applied to the lower 3 to 4 feet of an interior wall. It can be both functional and decorative.

Wall-hung lavatory

A lavatory hung on the wall, secured to wall studs.

Waste water and overflow drain

An assembly for a bathtub. The outlet at the top removes the overflow water during tub filling, and the drain at the bottom removes wastewater when the tub is drained.

Water closet

Another name for a toilet. The term “water closet” comes from a European home design that featured the toilet and a small lavatory in one room separated from a larger room housing the bathtub.

Wax finish

A simple, effective way of finishing wood. Generally, the wax is applied over a dried and sanded sealer coat of shellac, varnish, or oil.

Wear-thru

Wear that appears on the edge of doors, the raise of moldings, and other areas where a finish would naturally have been worn off through the continual opening and closing of doors over years of use. Wear also appears on door, drawer, and cabinet face frames.

Wheatboard

See “Bio-based architectural panels.”

Whitewash

A type of floor stain. The white-gray stain is a pigmented stain that creates color by causing finely ground particles to adhere to the floor's surface. Unlike a dye-based stain that penetrates the wood, a pigmented stain floats mostly on the floor's surface like paint.

Whole-house ventilation

A system designed to exhaust stale air and/or supply fresh air to an entire dwelling.

Wood grain

Grain is the alternating regions of relatively darker and lighter wood resulting from the differing growth parameters occurring in different seasons (i.e., growth rings).

Wood stain

Pigment or dye used to color wood, usually suspended in liquid or gel; stains may be water- or alcohol-based, or the pigment may be contained in the actual finishing agent (varnish, polyurethane, etc.).

Resources

Beyond the Basics . . . Advanced Kitchen Design

Author: Ellen Cheever, CMKBD, ASID, CAPS
National Kitchen & Bath Association (NKBA)
687 Willow Grove Street
Hackettstown, NJ 07840
www.nkba.org

The Basics of Bathroom Design . . . and Beyond

Author: Ellen Cheever, CMKBD, ASID, CAPS
National Kitchen & Bath Association (NKBA)
687 Willow Grove Street
Hackettstown, NJ 07840
www.nkba.org

Ellen Cheever, CMKBD, ASID, CAPS
Ellen Cheever & Associates
1904 Field Road
Wilmington, DE 19806
www.ellencheever.com
KBDN articles: www.forresidentialpros.com/contact/10373872/ellen-cheever

National Kitchen & Bath Association (NKBA)
687 Willow Grove Street
Hackettstown, NJ 07840
www.nkba.org

Kitchen & Bath Design News Magazine
www.forresidentialpros.com

Chapter 1

American Hardwood Information Center
Hardwood Manufacturers Association
665 Rodi Road, Suite 305
Pittsburgh, PA 15235
<http://hardwood.org/>

American National Standards Institute (ANSI)
1899 L Street, NW, 11th Floor
Washington, DC 20036
www.ansi.org

Architectural Graphic Standards (11th ed.),

John Wiley & Sons, Inc.
111 River Street
Hoboken, NJ 07030-5774
www.wiley.com

Artcraft Kitchens
4417 Kent Avenue
Niagara Falls, ON, L2H 1J1
Canada
www.artcraftkitchens.com

Blum Inc.
7733 Old Plank Road
Stanley, NC 28164
www.blum.com/us/en/

Builders Hardware Manufacturing Association (BHMA)
355 Lexington Avenue, 15th floor
New York, NY 10017
www.buildershardware.com

California Air Resources Compwood ATCM
California Air Resources Board
1001 "I" Street
Sacramento, CA 95814
www.arb.ca.gov

Composite Panel Association (CPA)
19465 Deerfield Avenue, Suite 306
Leesburg, VA 20176
www.decorativesurfaces.org

Columbia Forest Products
7900 Triad Center Drive, Suite 200
Greensboro, NC 27409
<http://columbiaforestproducts.com>

Enkeboll Designs
16506 Avalon Boulevard
Carson, CA 90746-1096
www.enkeboll.com

Forest Stewardship Council (FSC)
212 Third Avenue North, Suite 445
Minneapolis, MN 55401
<https://us.fsc.org/>

Formica Corporation
10155 Reading Road
Cincinnati, OH 45241
www.formica.com

Form Wood Industries, Inc.
1601 Production Drive
Jeffersonville, IN 47130
www.formwood.com

GreenCabinetSource.org
Kitchen Cabinet Manufacturers Association (KCMA)
1899 Preston White Drive
Reston, VA 20191-5435
www.GreenCabinetSource.org

Häfele America Co.
3901 Cheyenne Drive
Archdale, NC 27263
www.hafele.com/us/

International Code Council (ICC)
500 New Jersey Avenue, NW, 6th Floor
Washington, DC 20001
<http://www.iccsafe.org>

Kitchen Cabinet Manufacturers Association (KCMA)
1899 Preston White Drive
Reston, VA 20191-5435
www.kcma.org

National Association of Home Builders (NAHB)
1201 15th Street NW
Washington, DC 20005
www.nahb.org

David Newton, CMKBD
David Newton and Associates
P.O. Box 51706
Knoxville, TN 37919

Plain & Fancy Custom Cabinetry
2550 Stiegel Pike
Schaefferstown, PA 17088
www.plainfancycabinetry.com

Poggenpohl Möbelwerke GmbH
Poggenpohlstr. 1
32051 Herford
Germany
www.poggenpohl.com

Premier Custom-Built, Inc.
110 Short Street
New Holland, PA 17557-1515
www.premiercb.com

Rev-A-Shelf
2409 Plantside Drive
Jeffersontown, KY 40299
www.rev-a-shelf.com

Rutt HandCrafted Cabinetry
215 Diller Avenue
New Holland, PA 17557
www.ruttcabinetry.biz

USDA Forest Service
Mailstop: 1111
1400 Independence Avenue, SW
Washington, DC 20250-1111
www.fs.fed.us/

U.S. Department of Housing and Urban Development (HUD)
HUD Minimum Property Standards—Housing
451 7th Street S.W.
Washington, DC 20410
www.hud.gov
http://portal.hud.gov/hudportal/HUD?src=/program_offices/housing/rmra/mps/mpshome

Wellborn Cabinet, Inc.
38669 Highway 77 South
Ashland, AL 36251
www.wellborn.com

Wood-Mode Fine Custom Cabinetry
1 Second Street
Creamer, PA 17833
www.wood-mode.com

Chapter 2

Architectural Graphic Standards (11th ed.)
John Wiley & Sons, Inc.
111 River Street
Hoboken, NJ 07030-5774
www.wiley.com

Association of Home Appliance Manufacturers (AHAM)
1111 19th Street NW, Suite 402
Washington DC 20036
www.aham.org

BEST by Broan Range Hoods
926 W. State Street
Hartford, WI 53027
www.bestrangehoods.com

Cheng Design
2808 San Pablo Avenue
Berkeley, CA 94702
www.chengdesign.com

Cookware Manufacturers Association (CMA)
Hugh J. Rushing, Executive Vice President
P.O. Box 531335
Birmingham, AL 35253-1335
www.cookware.org

Corning Incorporated
One Riverfront Plaza
Corning, NY 14831 USA
www.corning.com

EnergyGuide Program
Federal Trade Commission
600 Pennsylvania Avenue, NW
Washington, DC 20580
www.consumer.ftc.gov/articles/0072-shopping-home-appliances-use-energyguide-label

Energy Star Program
US EPA—OAR
ENERGY STAR Hotline (6202J)
1200 Pennsylvania Avenue, NW
Washington, DC 20460
www.energystar.gov

Federal Trade Commission
600 Pennsylvania Avenue, NW
Washington, DC 20580
www.ftc.gov

Home Ventilating Institute (HVI)
3317 East Bell Road, Suite 101122
Phoenix, AZ 85032
www.hvi.org

International Code Council (ICC)
500 New Jersey Avenue, NW, 6th Floor
Washington, DC 20001
www.iccsafe.org

Jenn-Air® Appliances
553 Benson Road
Benton Harbor, MI 49022-2692
www.jennair.com

Meyer Corporation, U.S.
One Meyer Plaza
Vallejo, CA 94590
www.meyer.com

Miele, Inc.
9 Independence Way
Princeton, NJ 08540
www.mieleusa.com

Sub-Zero-Wolf
4717 Hammersley Road
Madison, WI 53744-4130
www.subzero-wolf.com

U.S. Department of Energy
1000 Independence Avenue, SW
Washington, DC 20585
www.energy.gov

U.S. Environmental Protection Agency
633 3rd Street NW
Washington, DC 20001
www.epa.gov

Chapter 3

American Standard
1 Centennial Plaza
Piscataway, NJ 08855-6820
www.americanstandard-us.com

American Supply Association (ASA)
1200 North Arlington Heights Road, Suite 150
Itasca, IL 60143
www.asa.net

DuPont Surfaces
Wilmington, DE
www.dupont.com

Elkay Manufacturing Company
2222 Camden Court
Oak Brook, IL 60523
www.elkayusa.com

Kohler Co.
444 Highland Drive
Kohler, WI 53044
www.kohler.com

MAAX Bath Inc.
160 St. Joseph Boulevard
Lachine, QC, H8S 2L3
Canada
www.maax.com

ROHL LLC
3 Parker
Irvine, CA 92618-1605
www.rohlhome.com

Chapter 4

American Supply Association (ASA)
1200 North Arlington Heights Road, Suite 150
Itasca, IL 60143
www.asa.net

American Standard
1 Centennial Plaza
Piscataway, NJ 08855-6820
www.americanstandard-us.com

Canyon Ranch
8600 E. Rockcliff Road
Tucson, AZ 85750
www.canyonranch.com

Geberit North America
2100 S. Clearwater Drive
Des Plaines, IL 60018-5999
www.geberitnorthamerica.com

International Code Council (ICC)
500 New Jersey Avenue NW, 6th Floor
Washington, DC 20001
www.iccsafe.org

Kohler Co.
444 Highland Drive
Kohler, WI 53044
www.kohler.com

Plumbing Manufacturers International (PMI)
1921 Rohlwing Road, Unit G
Rolling Meadows, IL 60008
www.pmihome.org

TOTO USA, INC.
1155 Southern Road
Morrow, GA 30260
www.totousa.com

U.S. Environmental Protection Agency
633 3rd Street NW
Washington, DC 20001
www.epa.gov

U.S. Department of Energy
1000 Independence Avenue SW
Washington, DC 20585
www.energy.gov

WaterSense
U.S. Environmental Protection Agency (EPA)
Office of Wastewater Management (4204M)
1200 Pennsylvania Avenue NW
Washington, DC 20460
www.epa.gov/watersense

Chapter 5

American Supply Association (ASA)
1200 North Arlington Heights Road, Suite 150
Itasca, IL 60143
www.asa.net

BRIZO
55 East 111th Street
Indianapolis, IN 46280
www.brizo.com

Decorative Plumbing & Hardware Association (DPHA)
7508 Wisconsin Avenue, 4th Floor
Bethesda, MD 20814
www.dpha.net

Delta Faucet Company
55 East 111th Street
Indianapolis, IN 46280
www.deltafaucet.com

Dornbracht Americas Inc.
1700 Executive Drive South, Suite 600
Duluth, GA 30096
www.dornbracht.com/en

Plumbing Manufacturers International (PMI)
1921 Rohlwing Road, Unit G
Rolling Meadows, IL 60008
www.pmihome.org

U.S. Environmental Protection Agency
633 3rd Street NW
Washington, DC 20001
www.epa.gov

U.S. Department of Energy
1000 Independence Avenue SW
Washington, DC 20585
www.energy.gov

WaterSense
U.S. Environmental Protection Agency (EPA)
Office of Wastewater Management (4204M)
1200 Pennsylvania Avenue NW
Washington, DC 20460
www.epa.gov/watersense

Chapter 6

American Association of Retired Persons (AARP)
601 E Street NW
Washington, DC 20049
www.aarp.org

American Supply Association (ASA)
1200 North Arlington Heights Road, Suite 150
Itasca, IL 60143
www.asa.net

Bathroom Manufacturers Association (BMA)
Innovation Centre 1
Keele University Science & Business Park
Newcastle-under-Lyme, ST5 5NB
U.K.
www.bathroom-association.org

Centers for Disease Control and Prevention (CDC)
1600 Clifton Road
Atlanta, GA 30333
www.cdc.gov

Certified Aging-in-Place Specialist (CAPS) Program
National Association of Home Builders (NAHB)
1201 15th Street NW
Washington, DC 20005
www.nahb.org

Mr. Steam®
Sussman-Automatic Corp®
43-20 34th Street
Long Island City, NY 11101
www.mrsteam.com

National Association of the Remodeling Industry (NARI)
P.O. Box 4250
Des Plaines, IL 60016
www.nari.org

Nationwide Children's Hospital
Center for Injury Research and Policy
700 Children's Drive
Columbus, OH 43205
www.nationwidechildrens.org/injury-research-and-policy

Plumbing Manufacturers International (PMI)
1921 Rohlwing Road, Unit G
Rolling Meadows, IL 60008
www.pmihome.org

U.S. Environmental Protection Agency (EPA)
633 3rd Street, N.W.
Washington, DC 20001
www.epa.gov

U.S. Department of Energy
1000 Independence Avenue SW
Washington, DC 20585
www.energy.gov

WaterSense
U.S. Environmental Protection Agency (EPA)
Office of Wastewater Management (4204M)
1200 Pennsylvania Avenue, N.W.
Washington, D.C. 20460
www.epa.gov/watersense

Chapter 7

Ceramic Association
www.ceramicassociation.com

Composite Panel Association (CPA)
19465 Deerfield Avenue, Suite 306
Leesburg, VA 20176
www.decorativesurfaces.org

Concrete Countertops: Design, Form and Finishes for the New Kitchen and Bath

Author: Fu-Tung Cheng with Eric Olsen
Taunton Press, 2002
63 South Main Street
Newton, CT 06470-5506

The Concrete Network
www.concretenetwork.com

ISSFA
Solid Surface Fabrication and More
www.issfa.net

National Association of Home Builders (NAHB)
1201 15th Street NW
Washington, D.C. 20005
www.nahb.org

National Association of the Remodeling Industry (NARI)
P.O. Box 4250
Des Plaines, IL 60016
www.nari.org

National Wood Flooring Association (NWFA)
111 Chesterfield Industrial Boulevard, Suite B
Chesterfield, MO 63005
www.nwfa.org

Natural Stone Council
P. O. Box 539
Hollis, NH 03049
www.naturalstonecouncil.org

North American Laminate Flooring Association (NALFA)
1747 Pennsylvania Avenue NW, Suite 1000
Washington, DC 20006
www.nalfa.org

344 RESOURCES

SEN Design Group
151 East Rosemary Street, Suite 202
Chapel Hill, NC 27514
www.sendesigngroup.com

Tile Council of North America (TCNA)
100 Clemson Research Boulevard
Anderson, SC 29625
www.tcnatile.com

Tiles of Spain
Tile of Spain Center
Trade Commission of Spain
2655 Le Jeune Road, Suite 1114
Coral Gables, FL 33134
www.tileofspainusa.com

World Floor Covering Association (WFCA)
2211 East Howell Avenue
Anaheim, CA 92806
www.wfca-pro.org

Index

- above-counter lavatory, 153, 154, 157, 158, 159, 161
- ABS, 62, 142, 186, 194
- accessories, bathroom, 4, 137, 164, 189, 195, 199, 208, 257
- accessory definition, 137, 155, 180, 189
- acetal, 194
- acrylic, 61, 63, 64, 139, 151, 195, 259, 268, 269
- fixtures, 139, 141, 142, 143, 174, 186, 227
- finishes, 139, 143, 144, 174, 195, 268
- adjustability (interior shelves), 39, 41, 42, 49
- aerator, 209, 210
- agri, 60, 90
- air-gap
 - dishwasher, energy saving, 107, 157
- alder, 65, 66, 67, 234
- alkyd paint, 268, 269
- American inches (cabinet sizes), 15, 16, 20, 25, 26, 39, 43, 44, 45, 48, 49, 51, 52, 90
- American inches (bathtubs), 139, 174, 176, 181, 182, 206, 207, 229
- anigre, 72, 74, 78
- appliances, 15, 23, 25, 31, 49, 91, 92, 95, 96, 97, 98, 100, 101, 102, 103, 104, 105, 106, 108, 115, 116, 117, 119, 120, 121, 122, 125, 127, 135
- appliance dimensions, 96
- appliance garage, 49, 51, 75
- appliance planning, 91, 92, 95, 96, 102, 106, 107, 111, 121, 125, 131, 133, 134, 155, 183, 245, 252, 272, 283
- apron sinks, 154, 155, 165
- ash, 65, 66, 78, 79, 80, 81, 281
- auto conversion feature, 119
- bamboo, 90, 261, 262, 284
- base cabinet, 250, 254, 281
- base unit(s), 2, 43, 49, 51, 120, 121, 125
- bath designer, 2, 6, 8, 9, 10, 13, 25, 52, 55, 72, 80, 90, 92, 141, 147, 151, 153, 164, 167, 184, 186, 191, 193, 195, 199, 200, 210, 212, 215, 222, 224, 230, 233, 239, 240, 246, 249, 251, 259, 268, 269, 271, 272, 282, 284
- bath sink planning guidelines, 132, 138, 139, 140, 142, 147, 158, 161, 183, 195, 209, 210, 216, 243, 259, 266, 281, 281
- bathroom accessories, 137, 138, 189, 195, 199, 208, 211, 216, 257
- bathroom cabinetry, 29, 51, 85, 142, 147, 157, 161, 209, 233, 234, 250, 252, 253, 254, 263, 265, 266, 269, 274, 281
- bathroom faucets, 138, 150, 158, 162, 163, 164, 173, 193, 194, 195, 196, 197, 198, 199, 200, 201, 205, 206, 207, 208, 209, 210, 211, 212, 217
- bathroom fitting design, 138, 173, 193, 194, 201, 209, 211, 215, 239
- bathroom floor plans, 142, 187, 195
- bathroom lavatory configurations, 137, 138, 139, 147, 147, 150, 151, 153, 154, 155, 156, 157, 158, 163, 164, 173, 192, 193, 281
- bathroom lavatory types (sinks), 138, 140, 147, 151, 147, 192, 201, 205, 210, 211, 217, 236, 237, 266, 283
- bathtub fixtures, 137, 138, 140, 141, 149, 151, 173, 174, 180, 189, 190, 194, 195, 196, 199, 211, 221, 236, 237, 284
- bath finishes, 193, 195, 196, 197, 198, 199, 209, 211, 218, 240, 243, 246, 249, 251, 252, 253, 257, 259, 261, 262, 263, 265, 266, 267, 268, 269, 271,, 279, 281, 284
- bathtub and whirlpool planning tips, 138, 139, 167, 173, 178, 181-183, 195, 211-213, 226, 231, 230, 253,
- bathtub and whirlpool types, 137, 139, 142, 147, 149, 150, 173, 174, 176, 178, 180, 181, 182, 183, 194, 195, 212, 213, 214, 219, 226
- bathtub fittings, 137, 138, 182, 193, 194, 195, 196, 199, 211, 215, 216, 239
- bathtub/shower combination fittings, 186, 187, 189, 195, 196, 199, 212, 216, 217, 231
- bathtub/shower combination units, 139, 186, 189, 190, 191, 192, 220
- bespoke kitchen, 5
- bidet fixtures, fittings, 137, 138, 153, 171, 172, 192
- bidet planning tips, 153, 171, 172, 173, 153
- bidet seat, 146, 153, 171, 172, 192
- birch, 65, 68, 80
- blind cabinet, 44, 49, 90
- bowl arrangement (lavatory)
 - bathroom lavatory types (sinks), 149, 153, 154, 155, 156, 158, 161, 163, 163, 164, 192, 199, 210, 211
- brass fittings, 154, 193, 194, 195, 196, 198, 209, 210
- Brazilian rosewood, 65
- bridge faucet, 202, 210
- bubinga, 65, 72, 74
- built-in equipment (kitchen), 51, 195, 252
- bulkhead, 48
- bump-out, 48
- butcher block, 235
- butt-join, 234, 278
- butt flooring, 262, 265
- butt joint drawer system, 20, 23

- c-channel pull, 83
- cabinet component, 1, 21, 22, 58, 75
 - Sinks (lavatory), 155, 157, 159, 161, 163, 164, 209, 211, 217, 230
- cabinet core materials, 58
- cabinet sizes, 3, 4, 31, 43, 155, 157
 - bath, 155, 157, 159, 161, 163, 164, 182, 209
 - kitchen, 155, 157, 209
- cabinet types, 2
- cabinetry (kitchen), 96, 98, 99, 100, 102, 103, 106, 107, 121, 123, 124, 125, 131, 155, 157, 209
- cabinetry dimensions, 16, 96
- cable drain, 215
- cast glass (fixtures), 138, 150, 164, 189, 227
- cast iron (fixtures), 138-141, 151, 154, 156, 157, 163, 174, 176, 194, 283
- cast polymer, 142, 187, 236, 237, 238, 239, 250, 259, 269, 284
- catalytic system (ovens), 120, 136
- center set faucet, 162, 202, 206, 207, 210, 217
- ceramic tile, 146, 151, 164, 171, 187, 195, 217, 227, 228, 239, 240, 242, 246, 249, 250, 251, 282
- cherry, 65, 68, 69, 80, 90, 234, 261
- chrome finishes, 31, 195, 196, 209
- coffeemakers, 115, 125
- coil elements, 95, 112, 113, 117, 119, 136
- color washing, 269
- colored coatings (fittings), 194, 195, 196, 198
- coloring woods, 81, 269
- combination valve, 170, 193, 194, 200, 201, 217
- combing, 81, 269
- commercial-type cooking equipment, 2
- components (framed cabinet), 21, 38, 89, 102
- components (frameless cabinet), 2, 11, 22, 23, 38, 39, 42, 89, 90
- composite panels, 61, 265, 266
- composite sinks, 139, 140, 154, 164
- conduction, 108, 109, 110, 112, 117, 136
- console table, 157, 158
- continuous cleaning system (ovens), 117, 118, 119, 120, 136
- continuous high-performance laminates, 62
- convection, 108, 109, 114, 115, 118, 119, 120, 121, 123, 136
- convection ovens, 109, 115, 116, 119, 120, 123
- conversions,
 - inches, 13, 106, 132, 155, 156, 157, 158, 161, 163, 171, 174, 176, 181, 182
 - mm, 13, 96, 132, 187
 - cm, 15
- cooking center, 91, 108, 121, 203, 205
- cooktop/sink cabinet, 48, 87, 155, 157
- cooktops/range tops. *See* Range hoods
- copper fixtures, 154, 194, 198, 199, 273
- cork flooring, 258-259
- corner cabinet (base), (wall), 44, 45, 46, 49, 90, 155, 163
- corner sinks, 155, 156, 208
- corner shower, 238
- corner tub, 174, 183
- countertop lavatory, 157, 159, 160, 161, 163, 164, 194, 195, 208, 210, 233, 248, 272, 273
- cowtailing, 83
- CPVC, 194
- crackle, 83, 269
- crazing, 237, 258, 284
- cultured marble, 24, 142, 151, 166, 186, 228, 237
- cultured onyx, 237
- custom cabinet, 2, 3, 4, 58, 63, 90, 123, 155, 157, 182, 208
- custom cabinetry, 4, 84, 123, 157, 161, 265, 273, 274, 279
- decorative tile, 171, 187, 240, 270
- demountable hinges, 38
- diagonal wall cabinet, 49
- dimensions (cabinetry), 12, 13, 15, 16, 38, 90, 96, 157, 159
- dishwasher
 - air-gap, 91, 94, 104, 105, 106, 107, 108, 136, 156, 157, 209, 252
 - energy saving, 94
- distressing, , 83, 90, 269
- diverter valve, 172, 211, 215, 224
- door styles, 2, 3, 44, 64, 83, 99, 103, 125, 251, 257, 266, 283
- bath, 178, 189, 190, 251
- door swing (refrigerator), 103
- double sinks (kitchen), 155, 156, 210
- dovetail drawer system, 18, 20, 23, 24
- downdraft ventilation system, 91, 123, 124, 125, 126, 128, 129, 131
- drain, 94, 104, 106, 157, 158, 159, 164, 167, 170, 171, 172, 176, 178, 181, 182, 183, 187, 188, 189, 190, 193, 203, 209, 215, 217, 218, 213, 237
- drainboard, 155, 164
- drawer cabinets, 44
- drawer guide (slide) systems, 41
- drawer/roll-out systems, 23
- dressing area, 229
- drinking fountain, 208,
- dyed veneers, 61, 259
- edge-banding choices, 62
- electric fryer cooktop, 125
- electric grills, 125
- electric ovens, 119
- electricity, 91, 92, 108, 117, 118, 119, 133, 166, 172, 181, 183, 184, 230, 250
- elm, 65, 78, 80
- energy consumption, 92, 217, 219, 227, 234
- Energy Guide, 93
- energy savings, 93, 94, 119
- Energy Star, 92, 93, 94, 135, 219
- engineered board, 20, 60, 64, 83, 262
- engineered stone
 - quartz composite, 269, 271
- English imperial system, 12, 15, 96, 224, 283
- fan jet, 106
- faucet attachments, 157, 193, 194, 201, 203, 208, 210, 217
- faucet electronic controls, 193, 200, 201, 208, 217
- faucet finish, 194, 195, 196, 197, 198, 199, 210
- faucet fitting, 196, 199, 205, 206
- faucet location, 138, 201, 209, 210
- faucet planning tips, 138, 157, 158, 161, 162, 163, 164, 173, 193, 200, 201, 205, 209, 210, 212
- faucet types, 155, 164, 172, 193, 194, 200, 201, 202, 204, 205, 206, 207, 210, 217
 - bath, 158, 161, 162, 163, 164, 173, 182, 200, 201, 202, 205, 207, 208, 209
 - kitchen, 194, 200, 201, 202, 203, 204, 205, 207, 208, 210
- faucet temperature control, 201, 210, 217
- faucet volume control, 170, 172, 172, 182, 189, 193, 201, 209, 217, 224, 225
- faux finish, 82, 196, 197, 198, 199, 269
- fiberglass (fixtures), 141, 142, 149, 151, 174, 186, 251
 - bath, 174, 182, 183, 202
 - kitchen, 202

- finishes, 234, 240, 246, 258, 259, 261, 266, 267, 269, 277
- finishing systems (wood), 80, 90, 142, 147, 149, 195, 234, 251, 261, 262, 263, 281
- fire clay (fixtures), 116, 140, 141, 147, 151
- fitted furniture cabinetry, 52, 102, 157
- fitted kitchen, 5
- fitting(s), 2, 12, 21, 137, 138, 158, 182, 199, 211, 215, 216, 222, 230, 231, 233
 - definition, 138, 158, 199, 210, 211, 215, 216, 230
 - finishes, 140, 150, 173, 182, 196, 210
 - materials, 137, 141, 144, 173, 195, 209
 - types, 2, 12, 21, 138, 172, 193, 194, 195, 199, 209, 210, 213, 214, 215, 216, 222, 230
- fitting design (bathroom), 138, 172, 173, 182, 183, 184, 201, 209, 211, 214, 215, 216, 220
- fixture construction, 138, 151, 162, 191, 193, 201, 215
- fixture definition, 138, 154, 165, 166, 173, 212
- fixture design, 139, 140, 153, 158, 167, 169, 216, 221, 222, 226
- fixture materials, 137, 139, 140, 142, 144, 146, 148, 149, 150, 151, 193, 195, 196
- fixture planning tips, 137, 138, 157, 153, 157, 161, 164, 167, 170, 171, 172, 173, 180, 182, 183, 184, 185, 190, 191, 212, 215, 229, 230
- fixture types, 167, 172, 174, 176, 178, 180, 185, 186, 192, 212, 216, 222, 229, 230
- flagstone, 273
- flat doors, 63, 83, 84
- floor tile installation, 195, 250, 251, 252, 257
- flush mounted sink, 154, 161, 164, 192, 266
- flushing methods, devices, 153, 169, 170, 171, 173, 182, 192, 227
- flushometer, 173
- food waste disposer, 91, 94, 104, 157, 209
 - energy saving, 91, 92
- four-inch center faucet set, 206
- frame construction, 18, 20, 23, 58, 102, 126, 187, 189
- frame panel door, 189, 190
- frameless construction, 2, 11, 18, 22, 23, 38, 39, 42, 58, 89, 90
- free-standing tubs, 142, 157, 174, 175, 190, 212, 214, 219, 239
- freezer, 97, 98, 99, 100, 103
- freezer location, 103
- gas, 91, 183, 230
- gas (cooking), 108, 109, 112, 113, 116, 117, 124, 132, 133
- gas and electric ranges, energy saving, 95, 119, 132, 133, 135, 136
- gasket (fitting), 194
- gas ovens, 117, 118, 119
- gas (refrigeration), 100, 101
- glass, 142, 149, 151, 190, 192, 196, 212, 219, 227, 240
- glass block, 227, 259
- glass ceramic cooktops, 95, 117, 118, 136, 164
- glass cookware, 113, 114, 115, 116
- glass door wall cabinet, 49, 50, 58, 86, 87, 99
- glass doors (refrigerator), 100, 101
- glass fixtures, 142, 149, 150, 189
- glass doors, 187, 189, 190, 212, 219, 227
- glass surfaces, 259, 260, 261
- glass tile, 240, 243, 244, 245, 246, 250, 251, 270
- glazed tile, 240, 242, 246, 284
- glazing (paint), 82, 269
- gold plate finishes (fittings), 195, 196, 197
- gooseneck faucet, 204, 208, 210
- granite, 235, 236, 237, 240, 241, 242, 245, 258, 267, 269, 271, 275, 276, 277, 278, 279, 280, 281, 282, 284
- greenhouse gas, 93
- griddle, 125, 133
- grout, 240, 246, 250, 251, 254, 257, 284
- halogen, 50, 112, 113, 117, 118
- hand-held shower, 138, 185, 211, 213, 215, 220, 221, 222, 224, 231
- hand-painted (fixtures),
- hard conversion, 13, 90, 96
- hardwood, 6, 7, 20, 22, 59, 63, 64, 65, 66, 70, 71, 79, 234, 261, 263, 264, 265
- heat sources, 108, 112, 116, 136, 172, 180, 208, 217, 230
- heat transference methods, 31, 91, 115, 185, 217, 228, 229, 230
- heating methods, 118, 181, 183, 217, 230
- heat protection, 234, 259, 262, 272, 274
- hickory, 69, 261
- high-pressure laminates, 61, 62, 63, 77, 265, 266, 267
- hinging, 38, 39, 90, 102, 111, 178, 189
 - Solid disk elements, 118
- hot-stamped transfer foils (HSTF), 61, 63, 284
- hot water dispenser, 157, 208
- hybrid construction (cabinet), 23
- ice dispenser, 100, 101
- induction, 108, 111, 112, 113, 114, 135, 136
- integral lavatory, 137, 156, 157, 158, 161, 208, 217
- integral mounting, 157, 164, 176, 208
- interior accessories, 50, 155, 156, 161, 164, 176, 195, 199, 208
- international cabinet makers, 96
- jet accessibility, 226
- jet placement, 170, 179, 182
- jetted bathtubs, 142, 153, 170, 180, 181, 185, 192, 226
- kitchen designer, 193, 195, 199, 200, 203, 210
- kitchen cabinets, sizes, 2, 3, 4, 31, 43, 44, 49, 52, 89, 90
- kitchen faucet, 196, 198, 200, 201, 203, 205, 210
- kitchen sink, 10, 33, 94, 104, 105, 106, 139, 140, 151, 153, 154, 155, 164, 192, 194, 199, 202, 204, 208
- kitchen waste management, 94, 104, 157
- lacewood, 65, 72
- lacquer, 63, 80, 81, 82, 83
- lacquer finish, 81
- lamine surfaces, 62
- laminated vinyl, 62
- Lazy Susan base cabinet, 44, 45
- living finishes, 150, 195, 198, 199
- lotion dispenser, 208
- low-profile hinges, 38
- lyptus, 70, 90
- mahogany, 65, 69, 70, 78, 80, 90
- make-up air, 133
- mantel/chimney hood, 125, 126
- maple, 65, 70, 78, 80
- marble, cultured, 24, 142, 151, 166, 186, 228

- massage experience, 178, 181, 182, 184, 185, 192, 222
 MDF carved doors, 85
 melamine, 61, 63, 85
 melamine/vinyl surfaces, 61, 62
 metal drawer system, 24
 metal finishes on fixtures, 140, 142, 147, 150, 164, 189, 194, 195, 196, 206
 method of cooling (refrigerator), 96, 97,
 metric cabinet sizes, 12, 14, 15, 18
 metric conversion (appliances), 13, 116
 metric system, 12, 13, 14, 15, 16, 18, 44, 77, 90, 224
 microwave cooking, 31, 49, 110, 115
 microwave ovens, 38, 49, 109, 110, 115, 120, 208
 microwave placement, 31, 49, 115, 120
 microwave planning tips, 49, 120, 115, 125
 microwave/TV cabinet, 49, 110, 111
 millwork design details, 87
 miscellaneous vanity cabinet
 nomenclature, 10, 51, 52, 53, 55, 56
 miter framed doors, 83, 86, 90
 miter framed drawer system, 24
 molding, 237, 253
 mortise-and-tenon doors, 85, 86, 90
 mosaic tile, 243, 246, 250, 270
 mounting methods, 140, 143, 145, 154, 164, 165, 166, 182, 209, 212, 213, 214, 215, 220, 221, 222, 223, 231, 239, 240, 243, 246, 283
 multiple-head shower design, 183, 185, 189, 211, 215, 222, 224, 225

 natural gas, 91, 116, 117
 natural stone, 228, 267, 271, 275, 278, 279, 280, 281, 282
 new wood, 233, 269
 NGR stain (non-grain-raising), 81

 oak, 8, 65, 70, 71, 75, 79, 80, 81, 258, 261, 262
 oil finish, 81, 82, 198, 234, 246, 262, 263, 268, 269, 281
 1.6 gpf toilets, 166, 169, 170, 171, 192
 one-piece toilet, 138, 141, 146, 147, 153, 168, 171, 253, 257
 open shelf unit, 49
 oven cleaning systems, 120, 136, 271
 oven types, 95, 109, 110, 111, 113, 114, 115, 116, 117, 119, 120, 121, 122, 123, 124, 125, 237
 ovens, 95, 113, 118, 119, 120, 123, 125, 136
 overhead vent system, 125, 126, 131, 132, 136

 paint (special effects), 60, 61, 63, 66, 81, 82, 83, 149, 269
 paint dragging, 81
 paint gloss, 63, 81, 82, 268
 painting, 81, 227, 268, 269, 271, 284
 particleboard, 7, 22, 59, 60, 62, 63, 65, 90, 265, 266
 pearwood, 65, 72
 pecan, 69, 261
 pedestal lavatory (sink), 147, 149, 157, 158, 159, 161, 162, 209, 211, 217, 237, 283
 penetrating resin-oil finish, 81, 82, 263, 280, 237, 263, 268
 penetrating wood sealer finish, 81, 234, 246, 263, 280, 281
 peninsula cabinet, 50, 248
 pewter finish (fittings), 199, 273
 pickled finishes, 81
 pie-cut cabinet, 45, 47, 49, 90
 pigmented wiping stain, 81, 263
 pine, 65, 71, 79, 80, 261
 pipe access
 bath, 158, 167, 170, 171, 182, 183, 200, 209, 215
 kitchen, 155, 200, 209, 228
 plastics (fixtures, fittings), 168, 174, 186, 187, 194, 195, 208, 209, 210, 217, 246, 259
 platform tubs, 143, 176, 178, 212, 214, 263
 plywood, 7, 20, 22, 59, 60, 65, 78, 79, 83, 90, 251, 254
 polyester laminate, 63, 195
 polyurethane finish, 81, 82, 235, 262, 263, 284
 polyurethane sealed wood counters, 81, 235, 284
 ponderosa pine, 65, 71
 pop-up and trip lever drain, 209, 215
 pot filler, 202, 203, 210
 prefinished wood counters, 234, 236, 278
 pressure balancing valve, 180, 216, 217, 225, 231
 primary cooking center, 31, 121, 261, 278
 pro Style faucet, 204, 209
 profile (shaped) edge, 24, 38, 60, 63, 78, 248
 pull-down faucet, 203, 204, 210
 pull-out faucet, 203, 209
 PVC, PVD finishes (fittings), 62, 63, 78, 83, 180, 196,
 pyrolytic systems, 117, 118, 119, 120, 136

 quarry tile, 246, 250, 284
 quartz composition (composite)
 Engineered stone, 139, 140, 165, 269, 271, 269

 radiation, 108, 109, 110, 117, 118, 136
 range hoods, 31, 89, 95, 109, 112-114, 117-119, 121, 123, 124, 125, 127, 131-133, 135
 recessed tubs, 157, 174, 176, 190
 reconstruction wood strips, 63, 234
 recycling center, 31, 33, 45, 47, 94, 157
 refrigeration center planning, 31, 101, 95, 96, 98, 155,
 refrigerator, 10, 49, 51, 95, 97
 refrigerator types, 51, 98, 99
 refrigerator workings, 31, 96, 100, 101
 refrigerator/freezer, 100
 energy saving, 93, 97
 resin-impregnated foil, 61, 85, 266, 284
 rimmed mounting, 164, 212
 round sinks (kitchen), 153, 155, 157,
 rubber, 155, 182, 194, 200, 250

 safety (shower), 174, 183, 216, 217, 229
 saunas, 185, 211, 226, 228, 229, 230
 scald protection devices, 181, 201, 211, 216, 217
 sealing woods, 81, 235, 262, 263, 284
 selecting appliances, 95
 selecting fixtures or fittings, 153, 158, 161, 164, 165, 168, 171, 172, 173, 178, 180, 184, 185, 190, 191, 193, 224, 230, 233
 self-rimming sink, 154, 156, 164
 self-rimming lavatory, 161, 164
 semi-custom cabinet, 2, 3, 4, 39, 90
 separate refrigerator and freezer, 96, 97, 99, 101, 103
 separate shower/bathtub, 176, 190, 186, 189, 190, 191, 192, 195, 211, 212, 215, 219, 222, 236, 237, 238, 248
 shower components, 138, 176, 187, 188, 189, 212, 219, 236, 237, 238

- shower fittings, 138, 183, 185, 193, 194, 196, 199, 201, 209, 210, 211, 219
- shower head flow rate, 186, 189
- shower heads, 138, 183, 185, 189, 201, 211, 222
- shower pans (with drain), 142, 143, 186, 187, 188
- shower fixtures, 176, 183, 186, 187, 190, 195, 211, 215, 222
- shower stall planning tips, 167, 174, 176, 183, 184, 185, 186, 189, 190, 195, 215, 219, 222, 248
- shower water patterns, 167, 186, 193
- shower/bathtub combination fittings, 176, 183, 189, 211, 212, 215, 217, 236, 238, 240
- shower/bathtub combination units, 176, 189, 190, 191, 212, 213, 215, 217, 248
- shut-off valve, 158, 161, 167, 209, 215, 216
- single-handle faucet, 161, 162, 193, 199, 201, 202, 205, 207, 210, 212, 215, 217
- single sinks (kitchen), 154, 155, 199, 266
- sink accessories (kitchen), 155, 156, 195, 199, 208, 210
- sink bowl (bath), 149, 153, 155, 199, 210, 217, 243
- sink configuration choices, 154, 156, 157, 163, 192, 194, 201, 202, 205, 217, 281
- sink/cooktop cabinet, 203
- sink/counter-section, combinations (kitchen), 233, 234, 235, 236, 241, 252, 257, 263, 270, 272, 274, 277, 278, 279, 281, 282, 284
- sink finishes, 198, 243, 263, 266, 281
- sink Fittings, 199, 202, 207, 208, 211, 212
- sink fixtures, 154, 200, 203, 205
- sink mounting methods, 145, 157, 164, 165
- sink planning tips (kitchen), 154, 156, 202, 203, 208, 209, 210, 252, 258, 259, 260, 271, 272, 274, 275, 277, 278, 279, 281, 282, 284
- sink types, 139, 155, 156, 164, 208, 243
 - lavatory (bath), 147, 154, 166, 207, 208, 209, 243, 281
 - kitchen, 138, 140, 142, 151, 154, 204, 207, 208
 - weight, 139, 161, 184
 - composites, 139, 140, 154, 161, 164, 281
 - slate, 228, 246, 273, 274, 280, 281, 282
 - slide-in ranges, 124, 125
 - sinks, 138, 139, 153, 154, 155, 156, 157, 163, 164, 193, 205, 208, 209, 210, 243, 266, 281
 - soap dispenser, 208
 - soapstone, 281
 - softwood, 7, 63, 64, 79, 261
 - solid disk elements
 - hobs, 118
 - solid surfacing (fixtures or finishes), 142, 144, 195, 217, 234, 252, 258, 269, 271, 272, 273, 284
 - slide-in range, 125, 202, 203, 208
 - spa bath, 153, 174, 181, 185, 227
 - spa experience, 178, 179, 180, 184, 229
 - splatter, 83
 - special purpose hinges, 4, 38, 39
 - special purpose hardware, 39, 189, 196, 202, 212
 - special purpose wire systems,
 - specialty appliances, 103, 125
 - specialty center panels, 86, 90
 - specialty doors, 4, 85, 86, 251
 - specialty glass doors, 86, 87, 103
 - specialty materials (in fixtures or finishes), 86, 137, 149, 150, 151, 154, 169, 194, 195, 199, 233, 234, 246, 257, 258, 263, 267, 269, 273
 - specialty veneers, 68, 72
 - spirit stain, 81
 - spout shapes (faucets), 138, 157, 158, 183, 200, 202, 203, 205, 206, 207, 208, 209, 210, 211, 212, 213, 215, 231, 212, 217
 - spray attachments, 138, 157, 185, 201, 204, 208, 210, 215, 219, 220, 221, 222, 224, 225, 231
 - square edge, 38, 164, 246, 257, 278
 - special purpose wall units, 39, 48, 49
 - staining woods, 80, 234, 235, 236, 258, 261, 263, 268, 269, 284
 - stainless steel, 24, 31, 100, 106, 107, 111, 113, 118, 140, 144, 145, 150, 151, 154, 155, 156, 157, 164, 165, 192, 195, 196, 210
 - stainless steel doors, 85, 86, 107, 272
 - steam showers, 186, 211, 226, 227, 228, 230, 231
 - steamer cooktop, 125
 - stippling, 269
 - Stock cabinets, 2, 3
 - stone fixtures, 150, 151, 154, 163, 165, 229, 274, 275, 277, 279, 280
 - stone installation, 25, 274, 281, 282
 - storage above refrigerator, 49, 98, 104
 - storage systems (cabinets), 1, 23, 24, 27, 31, 32, 35, 38, 90
 - storage tank toilets, 147, 167, 168, 181
 - strainer (kitchen sink), 157
 - striate, 82, 269
 - super natural woods, 76, 261
 - surfacing materials, 2, 61, 62, 70, 164, 187, 195, 217, 227, 239-284
 - tall units, 51, 52, 53
 - teak, 65, 80, 261
 - temperature limiting valve, 116, 117, 118, 119, 181, 183, 193, 210, 217, 231
 - terrazzo, 281
 - thermally fused melamine (TFM), 61, 62, 63, 85, 265, 266
 - thermostatic valve, 95, 106, 118, 119, 193, 217, 224, 225
 - thermostatically controlled surface units, 118, 228, 229
 - tile, 164, 171, 176, 187, 190, 195, 217, 227, 234-255, 257, 261, 262-264, 270, 275, 278, 280-282, 284
 - tile detailing, 151, 171, 176, 252, 250, 252, 253
 - tile grouts, 251
 - tile installation methods (floors), 151, 187, 190, 217, 251, 255, 269
 - tile planning tips, 146, 164, 171, 195, 217, 227, 248, 250, 253, 269, 271
 - tile overhangs, 254, 271
 - tile trim shapes, 171, 240, 246, 248, 249, 252
 - tiling around windows, 252-253
 - tinted varnish, 81, 263
 - toilet construction, 141, 146, 147, 167, 167, 168
 - toilet dimensions, 168, 170, 171, 183
 - toilet fixtures, 137, 138, 147, 162, 165, 167, 253, 257
 - toilet planning, 137, 147, 153, 165, 167, 168, 170, 171, 172, 173, 230, 253, 257
 - toilet seats, 167, 168
 - toilet types, 168-170
 - toilet water usage, 153, 166, 167, 168, 169, 170
 - top coating wood, 234, 235, 236, 259, 263, 265, 269, 284
 - top-mounted sink, 209
 - trash compactor, 105
 - travertine, 228, 281
 - trompe l'oeil, 269

- tub and whirlpool types, 137, 138, 139, 140, 141, 142, 143, 147, 149, 153, 173, 174, 175, 176, 177, 178, 179, 180, 181, 182, 183, 184, 185, 186, 190, 191, 192, 195, 212, 213, 214, 215, 217, 219, 226, 236, 237, 239, 248
- TV/microwave cabinet, 49, 110, 111, 120
- two-handle faucet, 199, 202, 206, 210, 217
- two-piece toilet, 147, 168, 171, 252, 253
- under-mount sinks, 209
 bath, 161, 164, 166, 192
 kitchen, 154, 157, 164, 192
- unfinished wood counters, 234, 235
- unfinished wood floors, 263
- unfitted kitchen, 5
- urinal fixtures, 138, 141, 146, 153, 167, 193
- vanity base cabinet nomenclature, 159, 163
- vanity base units, 10, 51, 52, 53, 55, 56, 159, 163, 164, 182, 251
- varnish stain, 81, 82, 234, 263
- veneer cutting, 74
- veneer doors, 75, 76
- veneer matching, 77
- veneer specifications, 75
- veneers, 6, 60, 62, 63, 64, 65, 69, 70, 72, 74, 76, 77, 78, 80, 83, 86, 259
- vent hood/microwave combination, 49
- ventilation, 9, 91, 108, 112, 120, 123, 124, 125, 126, 127, 129, 130, 131, 132, 133, 136, 183, 229
- vessel/above-counter lavatory, 149, 157, 163, 164, 192, 205, 207, 209
- vintage finishes, 81, 82, 90, 269
- vinyl resilient flooring, 251, 282, 284
- vinyl sheet, 251, 284
- vinyl tile, 251, 282
- vitreous china (fixtures), 141, 146, 147, 148, 149, 151, 167, 173
- wall-hung lavatory, 164
- wall-mounted faucet, 138, 202, 204, 207, 208, 210, 212, 215, 216, 221, 222, 223
- wall tile installation (bathroom), 171, 227, 246
- wallpaper, 268, 282, 283
- walnut, 234, 261
- warming drawers, 122, 123, 125
- water, 153, 155, 157, 164, 166, 167, 169, 170, 183, 185, 193, 193, 199, 201, 208, 209, 211, 212, 215, 216, 217, 219, 220, 221, 222, 223, 224, 226, 229, 230, 234, 237, 250, 263, 268, 278, 281
- water bath (cooking), 114, 115
- water patterns, 157, 161, 165, 166, 185, 204, 207, 221, 222, 223, 237
- water stain, 268, 272
- water temperature, 106, 136, 157, 179, 181, 183, 185, 201, 202, 205, 208, 216, 217, 219, 230, 234
- water treatment system, 157, 166, 167, 200, 209, 215
- wax finish, 262-263, 281
- wear through, 196, 234, 269, 278, 282
- whirlpool planning tips, 181, 182, 184
- whirlpool bathtub types, 142, 174, 180, 181, 182, 183
- widespread faucet, 161, 162, 207, 210
- wok cooking, 125
- wood (in fixtures), 154, 174, 176, 233, 234
- wood flooring (styles, finishing), 259, 261, 262, 265
- wood frame doors, 251, 283
- wood species, 234, 258, 261, 262, 268.
 See also individual wood species by name.
- wood veneers, 259
- zinc, 194-195

If you enjoyed this book, you may also like these:



Kitchen Planning 2e
by Kathleen Parrott, Julia Beamish, JoAnn Emmel,
and Mary Jo Peterson
ISBN: 9781118367629

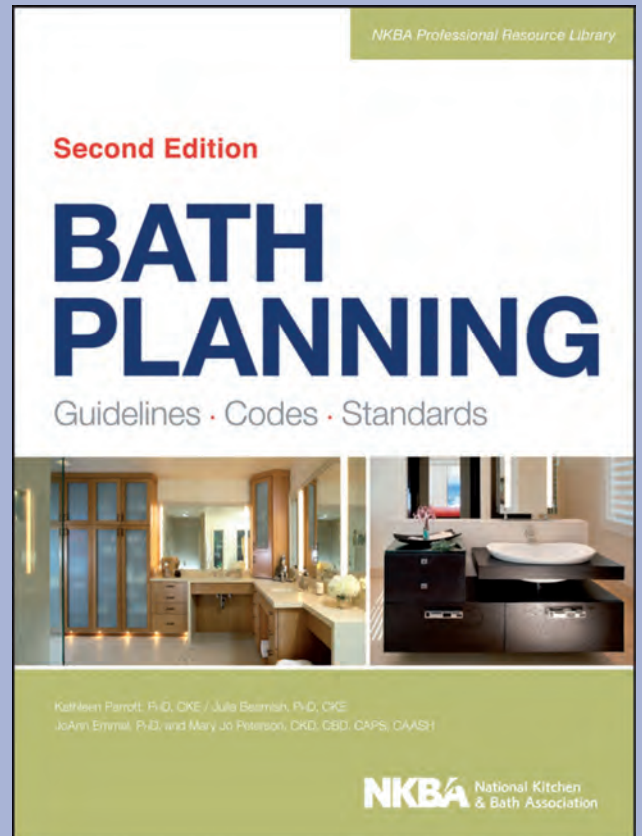

Bath Planning 2e
by Kathleen Parrott, Julia Beamish, JoAnn Emmel,
and Mary Jo Peterson
ISBN: 9781118362488

WILEY

WILEY END USER LICENSE AGREEMENT

Go to www.wiley.com/go/eula to access Wiley's ebook
EULA.