

Lighting Guide 7: Office lighting



The Society of
Light and Lighting



222 Balham High Road, London SW12 9BS, UK

Tel: 020 8675 5211. Fax: 020 8673 3302. e-mail: sll@cibse.org. www.sll.org.uk

The Society of Light and Lighting is part of the

Chartered Institution of Building Services Engineers

This document is based on the best knowledge available at the time of publication. However, no responsibility of any kind for any injury, death, loss, damage or delay however caused resulting from the use of these recommendations can be accepted by the Chartered Institution of Building Services Engineers, The Society of Light and Lighting, the authors or others involved in its publication. In adopting these recommendations for use each adopter by doing so agrees to accept full responsibility for any personal injury, death, loss, damage or delay arising out of or in connection with their use by or on behalf of such adopter irrespective of the cause or reason therefore and agrees to defend, indemnify and hold harmless the Chartered Institution of Building Services Engineers, The Society of Light and Lighting, the authors and others involved in their publication from any and all liability arising out of or in connection with such use as aforesaid and irrespective of any negligence on the part of those indemnified.

Note from the publisher

This publication is primarily intended to give guidance. It is not intended to be exhaustive or definitive, and it will be necessary for users of the guidance given to exercise their own professional judgement when deciding whether to abide by or depart from it.

The rights of publication or translation are reserved.

No part of this publication may be reproduced, stored in a retrieval system or transmitted in any form or by any means without the prior permission of the publisher.

© May 2005 The Society of Light and Lighting

Photographs kindly provided by: Artemide UK, Designed Architectural Lighting, Erco Lighting, Fielden Clegg Bradley Architects, Luxo (UK), Philips Lighting, Paul Ruffles, Thorn Lighting, R G Venning, Zumtobel Staff Lighting

The Society is part of CIBSE which is a registered charity, number 278104.

ISBN 1 903287 52 9

Typeset by the Society of Light and Lighting.

Printed in England by Page Bros. (Norwich) Ltd., Norwich, Norfolk NR6 6SA.

Foreword

This new edition of the Lighting Guide: *Office lighting* replaces the previous 1993 version. This new edition has been produced to ensure that our guidance is up to date with modern office lighting practice and to illustrate varying ways of lighting the modern office environment. The opportunity has been taken to give expanded advice on lighting many types of specialist spaces that occur in modern offices. Illumination recommendations have been aligned where appropriate with the new European Standards on lighting and the Society of Light & Lighting's *Code for Lighting*.

This edition supersedes the 1993 version and also incorporates the guidance on lighting office areas where display screen equipment is in use. This used to be contained in the separate publication, Lighting Guide 3: *The visual environment for display screen use*.

Author

Paul Ruffles (Lighting Design & Technology)

Support team

Mark Ayers (Lightform Special Products Ltd)

Jonathan David (The Society of Light & Lighting)

Peter LeManquais (Wila Lighting Ltd)

Peter Raynham (Bartlett School of Graduate Studies, UCL)

Bob Venning (Arup Lighting)

Barrie Wilde (BDP Lighting)

Glossary

Accommodation

Adjustment of the power of the lens of the eye for the purpose of focusing an image of an object on the retina.

Technically defined: Adjustment of the dioptric power of the crystalline lens by which the image of an object, at a given distance, is focused on the retina.

Adaptation

Process which takes place as the visual system adjusts to the luminance and colour of the visual field or the final state of this process.

Technically defined: The process by which the state of the visual system is modified by previous and present exposure to stimuli that may have various luminances, spectral distributions and angular subtenses.

Note 1: The terms light adaptation and dark adaptation are also used, the former when the luminances of the stimuli are of at least several candelas per square metre, and the latter when the luminances are of less than some hundredths of a candela per square metre.

Note 2: Adaptation to specific spatial frequencies, orientations, sizes etc. are recognised as being included in this definition.

Average illuminance

Illuminance averaged over the specified area.

Note: In practice this may be derived either from the total luminous flux falling on the surface divided by the total area of the surface, or alternatively from an average of the illuminances at a representative number of points on the surface.

Unit: lux (lx)

Average luminance (L_{av})

Luminance averaged over the specified area or solid angle.

Unit: candela per square metre (cd/m^2)

Ballast

A device connected between the supply and one or more discharge lamps which serves mainly to limit the current of the lamp(s) to the required value.

Note: A ballast may also include means of transforming the supply voltage, correcting the power factor and, either alone or in combination with a starting device, provide the necessary conditions for starting the lamp(s).

Brightness contrast

Subjective assessment of the difference in brightness between two or more surfaces seen simultaneously or successively.

Brightness

Attribute of the visual sensation associated with the amount of light emitted from a given area. It is the subjective correlate of luminance.

Technically defined: brightness, luminosity (obsolete): Attribute of a visual sensation according to which an area appears to emit more or less light.

Chromaticity

Property of a colour stimulus defined by its chromaticity coordinates, or by its dominant or complementary wavelength and purity taken together.

Colour contrast

Subjective assessment of the difference in colour between two or more surfaces seen simultaneously or successively.

Colour rendering (of a light source)

Effect of a light source on the colour appearance of objects compared with their colour appearance under a reference light source.

The definition is more formally expressed as: Effect of an illuminant on the colour appearance of objects by conscious or subconscious comparison with their colour appearance under a reference illuminant.

Colour rendering index (of a light source) (R_a)

Value intended to specify the degree to which objects illuminated by a light source have an expected colour relative to their colour under a reference light source.

Note: R_a is derived from the colour rendering indices for a specified set of 8 test colour samples. R_a has a maximum of 100, which generally occurs when the spectral distributions of the light source and the reference light source are substantially identical.

Colour stimulus

Visible radiation entering the eye and producing a sensation of colour, either chromatic or achromatic.

Colour temperature (T_C)

The temperature of a Planckian (black body) radiator whose radiation has the same chromaticity as that of a given stimulus. Used to describe how “warm” or “cool” the light from a lamp appears.

Unit: kelvin (K)

Note: The reciprocal colour temperature is also used, unit K^{-1} .

Contrast

In the perceptual sense: Assessment of the difference in appearance of two or more parts of a field seen simultaneously or successively (hence: brightness contrast, lightness contrast, colour contrast, simultaneous contrast, successive contrast etc.)

In the physical sense: Quantity intended to correlate with the perceived brightness contrast, usually defined by one of a number of formulae which involve the luminances of the stimuli considered, for example: ΔUL near the luminance threshold, or L_1/L_2 for much higher luminances.

Daylight

Visible part of global solar radiation.

Note: When dealing with actinic effects of optical radiations, this term is commonly used for radiations extending beyond the visible region of the spectrum.

Daylight factor (*D*)

Ratio of the illuminance at a point on a given plane due to the light received directly or indirectly from a sky of assumed or known luminance distribution, to the illuminance on a horizontal plane due to an unobstructed hemisphere of this sky. The contribution of direct sunlight to both illuminances is excluded.

Note 1: Glazing, dirt effects etc are included.

Note 2: When calculating the lighting of interiors, the contribution of direct sunlight must be considered separately.

Diffuse sky radiation

That part of solar radiation which reaches the Earth as a result of being scattered by the air molecules, aerosol particles, cloud particles or other particles.

Direct lighting

Lighting by means of luminaires having a distribution of luminous intensity such that the fraction of the emitted luminous flux directly reaching the working plane, assumed to be unbounded, is 90% to 100

Direct solar radiation

That part of the extraterrestrial solar radiation which as a collimated beam reaches the Earth's surface after selective attenuation by the atmosphere.

Directional lighting

Lighting in which the light on the working plane or on an object is incident predominantly from a particular direction.

Disability glare

Glare that impairs the vision of objects without necessarily causing discomfort.

Note: Disability glare may be produced directly or by reflection.

Discomfort glare

Glare that causes discomfort without necessarily impairing the vision of objects.

Note: Discomfort glare may be produced directly or by reflection.

Emergency lighting

Lighting provided for use when the supply to the normal lighting fails.

Escape lighting

That part of the emergency lighting which is provided to ensure that the escape route is illuminated at all material times

Floodlighting

Lighting of a scene or object, usually by projectors, in order to increase considerably its illuminance relative to its surroundings.

General lighting

Substantially uniform lighting of an area without provision for special local requirements.

Glare

Condition of vision in which there is discomfort or a reduction in the ability to see details or objects, caused by an unsuitable distribution or range of luminance, or to extreme contrasts.

See also: Disability glare and Discomfort glare

Global solar radiation

Combined direct solar radiation and diffuse sky radiation.

Illuminance (at a point of a surface) (E)

Quotient of the luminous flux dF_V , incident on an element of the surface containing the point, by the area dA of that element.

Equivalent definition. Integral, taken over the hemisphere visible from the given point, of the expression

$$L \cos q \, dW$$

where L is the luminance at the given point in the various directions of the incident elementary beams of solid angle dW , and q is the angle between any of these beams and the normal to the surface at the given point.

Unit: lux (lx) = lumens per square metre

Note: The orientation of the surface may be defined, e.g. horizontal, vertical hence horizontal illuminance, vertical illuminance.

Indirect lighting

Lighting by means of luminaires having a distribution of luminous intensity such that the fraction of the emitted luminous flux directly reaching the working plane, assumed to be unbounded, is 0 to 10%.

Lamp

Source made in order to produce an optical radiation, usually visible.

Note: This term is also sometimes used for certain types of luminaires.

Light output ratio (of a luminaire)

Ratio of the total flux of the luminaire, measured under specified practical conditions with its own lamps and equipment, to the sum of the individual luminous fluxes of the same lamps when operated outside the luminaire with the same equipment, under specified conditions.

Note: For luminaires using incandescent lamps only, the optical light output ratio and the light output ratio are the same in practice.

Localised lighting

Lighting designed to illuminate an area with a higher illuminance at certain specified positions, for instance those at which work is carried out.

Local lighting

Lighting for a specific visual task, additional to and controlled separately from the general lighting.

Luminaire

Apparatus which distributes, filters or transforms the light transmitted from one

or more lamps and which includes, except the lamps themselves, all the parts necessary for fixing and protecting the lamps and, where necessary, circuit auxiliaries together with the means for connecting them to the electric supply.

Note: The term lighting fitting is deprecated.

Luminance (L)

Luminous flux per unit solid angle transmitted by an elementary beam passing through the given point and propagating in the given direction, divided by the area of a section of that beam normal to the direction of the beam and containing the given.

It can also be defined as: The luminous intensity of the light emitted or reflected in a given direction from an element of the surface, divided by the area of the element projected in the same direction.

The illuminance produced by the beam of light on a surface normal to its direction, divided by the solid angle of the source as seen from the illuminated surface. It is the physical measurement of the stimulus which produces the sensation of brightness.

Unit: candela per square metre (cd/m^2)

Luminance contrast

Physical quantity intended to correlate with brightness contrast, usually defined by one of a number of formulae which involve the luminances of the stimuli considered (see also Contrast)

Note: Luminance contrast may be defined as luminance ratio

$$C_1 = L_2/L_1 \text{ (usually for successive contrasts),}$$

or by the following formula:

$$C_2 = (L_2 - L_1) / L_1 \text{ (usually for surfaces viewed simultaneously),}$$

when the areas of different luminance are comparable in size and it is desired to take an average, the following formula may be used instead:

$$C_3 = (L_2 - L_1) / 0.5(L_2 + L_1)$$

where: L_1 is the luminance of the background, or largest part of the visual field; L_2 is the luminance of the object.

Luminous efficacy of a source (h)

Quotient of the luminous flux emitted by the power consumed by the source.

Unit: lumens per watt (lm/W)

Note 1: It must be specified whether or not the power dissipated by auxiliary equipment such as ballasts etc, if any, is included in the power consumed by the source.

Note 2: If not otherwise specified, the measurement conditions should be the reference conditions specified in relevant IEC standard; see Rated Luminous Flux.

Luminous environment

Lighting considered in relation to its physiological and psychological effects.

Luminous flux

Quantity derived from radiant flux (radiant power) by evaluating the radiation

according to the spectral sensitivity of the human eye (as defined by the CIE standard photometric observer). It is the light power emitted by a source or received by a surface.

Unit: lumen (lm)

Note 1: In this definition, the values used for the spectral sensitivity of the CIE standard photometric observer are those of the spectral luminous efficiency function $V(\lambda)$

Note 2: See IEC 50 (845) (CIE 17.4); 845-01-22 for the definition of spectral luminous efficiency, 845-01-23 for the definition of the CIE standard photometric observer and 845-01-56 for the definition of luminous efficacy of radiation. See also ISO/CIE 10527.

Luminous intensity (of a point source in a given direction) (I)

Luminous flux per unit solid angle in the direction in question, i.e. the luminous flux on a small surface, divided by the solid angle that the surface subtends at the source.

Unit: candela = lumen per steradian (lm/sr)

Maintained illuminance

Value below which the average illuminance on the specified area should not fall. It is the average illuminance at the time maintenance should be carried out.

Unit: lux (lx)

Maintenance cycle

Repetition of lamp replacement, lamp/ luminaire cleaning and room surface cleaning intervals.

Maximum luminance (L_{\max})

Highest luminance of any relevant point on the specified surface.

Note: The relevant points at which the luminances are determined shall be specified in the appropriate application standard.

Unit: candela per square metre.

Rated luminous flux (of a type of lamp)

The value of the initial luminous flux of a given type of lamp declared by the manufacturer or the responsible vendor, the lamp being operated under specified conditions.

Unit: lumens

Note 1: For most lamps, in reference conditions the lamps is usually operating at an ambient temperature of 25°C in air, freely suspended in a defined burning position and with a reference ballast, but see the relevant IEC standard for the particular lamp.

Note 2: The initial luminous flux is the luminous flux of a lamp after a short ageing period as specified in the relevant lamp standard.

Note 3: The rated luminous flux is sometimes marked on the lamp.

Reference lamp

A discharge lamp selected for the purpose of testing ballasts and which, when

associated with a reference ballast under specified conditions, has electrical values which are close to the objective values given in a relevant specification.

Reference surface

Surface on which illuminance is measured or specified.

Reflectance (r)

Ratio of luminous flux reflected from a surface to the luminous flux incident on it.

Note: The reflectance generally depends on the spectral distribution and polarization of the incident light, the surface finish and the geometry of the incident and reflected light relative to the surface.

Room index

An index related to the dimensions of a room and used when calculating the utilisation factor and other characteristics of the lighting installations:

$$\text{Room index} = L - W / [h_m(L + W)]$$

where L is the length of the room, W the width and h_m the height of the luminaires above the working plane.

Safety lighting

That part of emergency escape lighting that provides illumination for the safety of people involved in a potentially dangerous process or situation and to enable proper shut down procedures for the safety of the operator and other occupants of the premises (known as 'high risk task area lighting' in BS 5266-7/EN 1838).

Solar radiation

Electromagnetic radiation from the Sun.

Spacing (in an installation)

Distance between the light centres of adjacent luminaires of the installation.

(Spatial) distribution of luminous intensity (of a lamp or luminaire)

Display, by means of curves or tables, of the value of the luminous intensity of the source as a function of direction in space.

Standby lighting

That part of the emergency lighting which may be provided to enable normal activities to continue.

Stroboscopic effect

Apparent change of motion and/or appearance of a moving object when the object is illuminated by a light of varying intensity.

Note. To obtain apparent immobilisation or constant change of movement, it is necessary that both the object movement and the light intensity variation are periodic, and some specific relation between the object movement and light variation frequencies exists. The effect is only observable if the amplitude of the light variation is above certain limits. The motion of the object may be rotational or translational.

Sunlight

Visible part of direct solar radiation

Note: When dealing with actinic effects of optical radiations, this term is commonly used for radiations extending beyond the visible region of the spectrum.

Transmittance (t)

Ratio of the luminous flux transmitted through a body to the luminous flux incident on it.

Note: The transmittance generally depends on the direction, polarization and spectral distribution of the incident light and on the surface finish.

Utilisation factor

Ratio of the luminous flux received by the reference surface to the sum of the rated lamp luminous fluxes of the lamps in the installation.

Veiling reflections

Specular reflections that appear on the object viewed and partially or wholly obscure details by reducing contrast.

Visual comfort

Subjective condition of visual well being induced by the visual environment.

Visual field

Area or extent of physical space visible to an eye at a given position and direction of view.

Note: The visual field may be either monocular or binocular

Working plane

The horizontal, vertical or inclined plane in which the visual task lies. If no information is available, the working plane may be considered to be horizontal and at 0.8 m above the floor.

Bibliography

- Code for Lighting* (London: The Society of Light and Lighting) (2004)
- Lighting Guide 1: *Industrial lighting* (London: Society of Light and Lighting) (2002, 2004) (as part of Code for Lighting CD-ROM)
- Lighting Guide 5: *Lecture, teaching and conference rooms* (London: CIBSE) (1991)
- Lighting Guide 6: *The outdoor environment* (London: CIBSE) (1992)
- Lighting Guide 8: *Museums and art galleries* (London: CIBSE) (1994)
- Lighting Guide 9: *Lighting for communal residential buildings* (London: CIBSE) (1997)
- Lighting Guide 10: *Daylighting and window design* (London: CIBSE) (1999)
- Lighting Guide 11: *Surface reflectance and colour* (London: The Society of Light and Lighting) (2001)
- Lighting Guide 12: *Emergency lighting design guide* (London: The Society of Light and Lighting) (2004)
- Guide to fibre optic and remote source lighting* (London/Rugby: The Society of Light and Lighting/Institution of Lighting Engineers) (2001)
- Commissioning Code L: *Lighting* (London: CIBSE) (2003)
- Technical Memoranda 14: *Standard file format for transfer of luminaire photometric data* (London: CIBSE) (1988)
- Technical Memoranda 28: *Benchmarking lighting design software* (London: CIBSE) (2000)
- Technical Memoranda 35: *Environmental performance toolkit for glazed façades* (London: CIBSE) (2004)
- Bell, J, and Burt W: BR288 *Designing buildings for daylight* (Garston: Construction Research Communications) (1995)
- Boyce, P R: *Human factors in lighting* (Abingdon: Taylor & Francis) (2003)
- Cuttle, C: *Lighting by design* (London: Architectural Press) (2003)
- Littlefair, P J, and Aizlewood, M E: *Calculating access to skylight, sunlight and solar radiation on obstructed sites in Europe* (Garston: Building Research Establishment) (1999)
- Littlefair, P J: BR305 *Designing with innovative daylight* (Garston: Building Research Establishment) (London: Construction Research Communications) (1996)
- Littlefair, P J: BR209 *Site layout planning for daylight and sunlight: a guide to good practice* (Garston: Building Research Establishment) (London: Construction Research Communications) (1991)
- Littlefair, P J: *Solar shading of buildings* (Garston: Building Research Establishment) (1999)
- Loe, D, and Mansfield, K P: *Daylighting design in architecture. Making the most of a natural resource* (Garston: Building Research Establishment) (1998)
- Phillips, D R H: *Daylighting: natural light in architecture* (London: Elsevier) (2004)
- Steffy, G R: *Architectural lighting design* (Chichester: Wiley) (2001)
- Tregenza, P R, and Loe, D L: *The design of lighting* (London: E & F Spon) (1998)
- Marsden, A M, and Coaton, J R: *Lamps and lighting* (Chichester: Wiley) (1996)
- The Building Regulations 2000 Approved Document L2 *Conservation of fuel and power in buildings other than dwellings* (Norwich: The Stationery Office) (2002)
- Health and Safety Executive: *The Construction (Design and Management) Regulations 1995* (Norwich: The Stationery Office) (1995)

- The Workplace (Health, Safety and Welfare) Regulations 1992*. SI 1992 No 3004 (Norwich: The Stationery Office) (1992)
- BS 4800 *Schedule of paint colours for building purposes* (London: British Standards Institution) (1989)
- BS 5266 *Emergency lighting* (London: British Standards Institution) (seven parts, various dates)
- BS 6941 *Specification for electrical apparatus for explosive atmospheres with type of protection 'n'* (London: British Standards Institution) (1988) (being replaced by BSEN 50021)
- BS 8206-2 *Lighting for buildings. Code of practice for daylighting* (London: British Standards Institution) (1992)
- BSEN 12464-1 *Light and Lighting. Lighting of indoor work places* (London: British Standards Institution) (2002)
- BS EN ISO 29241, *Ergonomic requirements for office work with visual display terminals* (London: British Standards Institution) (many parts, various dates)
- BSEN 50021 *Electrical apparatus for potentially explosive atmospheres. Type of protection 'n'* (London: British Standards Institution) (1999) (replaced by BSEN 60079-15: 2003 but remains current)
- BSEN 60079-0 *Electrical apparatus for explosive gas atmospheres. General requirements* (London: British Standards Institution) (2004)
- BSEN 60079-14 *Electrical apparatus for explosive gas atmospheres. Electrical installations in hazardous areas (other than mines)* (London: British Standards Institution) (2003)
- BSEN 60079-15 *Electrical apparatus for explosive gas atmospheres. Type of protection 'n'* (London: British Standards Institution) (2003)
- CIE 117 *Discomfort glare in interior lighting* (Vienna: International Commission on Illumination) (1995)
- Guide for the application of Directive 2000/55/EC on energy efficiency requirements for ballasts for fluorescent lighting* (Brussels: Federation of National Manufacturers Associations for Luminaires and Electrotechnical Components for Luminaires in the European Union) (2003)
- Health and Safety Executive HSG(38) *Lighting at work* (Sudbury: HSE Books) (1998)
- Health and Safety Executive L26 *Display screen equipment work. Guidance on regulations* (Sudbury: HSE Books) (1992)
- Health and Safety Executive INDG(173) *Officewise* (Bootle: HSE) (free to download from <http://www.hse.gov.uk/hthdir/noframes/dse.htm>)
- Health and Safety Executive INDG(36) *Working with VDUs* (Bootle: HSE) (free to download from <http://www.hse.gov.uk/hthdir/noframes/dse.htm>)
- Health and Safety Executive HSG(90) *VDUs - an easy guide to the regulations* (Sudbury: HSE Books) (2003)
- Dubois, M-C: Shading devices and daylight quality: an evaluation based on simple performance indicators, *Ltg Res. Technol.*, 35 (1), pp 61-76 (2003)

References

- 1 Lighting Guide 12: *Emergency lighting design guide* (London: The Society of Light and Lighting) (2004)
- 2 Lighting Guide 11: *Surface reflectance and colour* (London: The Society of Light and Lighting) (2001)
- 3 The Building Regulations 2000 Approved Document L2 *Conservation of fuel and power in buildings other than dwellings* (Norwich: The Stationery Office) (2002)
- 4 *Code for Lighting* (London: The Society of Light and Lighting) (2004)
- 5 Health and Safety Executive HSG(38) *Lighting at work* (Sudbury: HSE Books) (1998)
- 6 BS 4800 *Schedule of paint colours for building purposes* (London: British Standards Institution) (1989)
- 7 *Guide for the application of Directive 2000/55/EC on energy efficiency requirements for ballasts for fluorescent lighting* (Brussels: Federation of National Manufacturers Associations for Luminaires and Electrotechnical Components for Luminaires in the European Union – CELMA) (2003)
- 8 *Photoelectric control of lighting: design, set-up and installation issues*, BRE Information Paper IP 2/99 (Garston: Building Research Establishment) (1999)
- 9 Littlefair, P: *Daylight linked lighting control in the Building Regulations* (Garston: Building Research Establishment) (1999)
- 10 Health and Safety Executive: *The Construction (Design and Management) Regulations 1995* (Norwich: The Stationery Office) (1995)
- 11 BSEN 12464-1 *Light and Lighting. Lighting of indoor work places* (London: British Standards Institution) (2002)
- 12 Loe, D, and Mansfield, K P: *Daylighting design in architecture. Making the most of a natural resource* (Garston: Building Research Establishment) (1998)
- 13 BS 8206-2 *Lighting for buildings. Code of practice for daylighting* (London: British Standards Institution) (1992)
- 14 *The Workplace (Health, Safety and Welfare) Regulations 1992*. SI 1992 No 3004 (Norwich: The Stationery Office) (1992)
- 15 Lighting Guide 10: *Daylighting and window design* (London: CIBSE) (1999)
- 16 Technical Memoranda 35: *Environmental performance toolkit for glazed façades* (London: CIBSE) (2004)
- 17 CIE 117 *Discomfort glare in interior lighting* (Vienna: International Commission on Illumination) (1995)
- 18 Lighting Guide 5: *Lecture, teaching and conference rooms* (London: CIBSE) (1991)
- 19 Lighting Guide 8: *Museums and art galleries* (London: CIBSE) (1994)
- 20 Lighting Guide 1: *Industrial lighting* (London: The Society of Light and Lighting) (2002, 2004) (as part of Code for Lighting CD-ROM)
- 21 BSEN 60079 *Electrical apparatus for explosive gas atmospheres. Several Parts* (London: British Standards Institution) (see also further references in the Bibliography)
- 22 Hunt, D R G: *Availability of daylight* (Garston: Building Research Establishment) (1979)
- 23 *Sunlight availability protractor* (Garston: Construction Research Communications) (2000)

Contents

	Foreword	3
1	Introduction	7
2	Design process	7
3	Design brief and information	8
	3.1 Client/user types	8
	3.1.1 New installations for a known user	8
	3.1.2 Speculative space for an unknown user	10
	3.2 Building types	11
	3.2.1 Self-contained office buildings	11
	3.2.2 Smaller offices	11
	3.2.3 Shared office space	12
	3.2.4 Areas where office work is carried out within other building types	13
	3.2.5 Refurbished buildings	13
	3.3 Design criteria	15
	3.3.1 Selection of illuminance	15
	3.3.2 Room décor and surface reflectance	16
	3.3.3 The effect of re-locatable walls on lighting levels	18
4	Design options for electric lighting	20
	4.1 Preliminary decisions	20
	4.1.1 The physical restrictions of the space	20
	4.1.2 Lighting styles	21
	4.1.3 Services options	22
	4.1.4 Lighting techniques	22
	4.2 Designing with localised lighting	22
	4.3 Designing with supplementary task lighting	24
	4.4 Energy Usage	25
	4.5 Controls	25
	4.6 Designing with direct lighting	27
	4.6.1 Luminaire layout with direct lighting	29
	4.6.2 Direct lighting and display screens	30
	4.7 Designing with indirect lighting	33
	4.7.1 Surface reflectance and decor	33
	4.7.2 Design criteria for indirect lighting	34
	4.7.3 Luminaire selection for indirect lighting	34
	4.8 Designing with direct/indirect Lighting	36
	4.8.1 Luminaire selection for direct/indirect lighting	37
	4.9 Designing with a combination of direct light and indirect light	38
5	Design options for daylighting	39
	5.1 Interaction between daylight and electric light	40
	5.2 Daylight and display screens	41
	5.3 Window and glazing design	42
	5.3.1 Glazing options	43
	5.3.2 Internal window shading options	43
	5.3.3 External window shading options	44

Contents

(continued)

6	Detailed room design information	45
6.1	Primary office space	46
6.1.1	Open-plan offices	46
6.1.2	Deep-plan areas	47
6.1.3	Cellular offices	47
6.1.4	Graphics work stations	47
6.1.5	Dealing rooms	48
6.1.6	Executive offices	49
6.2	Secondary office space	49
6.2.1	Meeting rooms	49
6.2.2	Training rooms	50
6.2.3	Conference rooms	50
6.2.4	Board rooms	51
6.2.5	Reprographics rooms	51
6.2.6	Libraries/information centres	51
6.2.7	Archives/document stores	51
6.2.8	Tea points/rest rooms	52
6.2.9	Sick bays/medical rooms	52
6.2.10	Canteens/restaurants	52
6.3	Circulation areas	53
6.3.1	Entrance halls/reception	53
6.3.2	Atria	53
6.3.3	Stairs/escalators	56
6.3.4	Lift lobbies	56
6.3.5	Corridors	56
6.4	Back-of-house areas	57
6.4.1	Security/building control rooms	57
6.4.2	Cleaners' cupboards	57
6.4.3	Plant rooms	57
6.4.4	Workshops	58
6.4.5	Lift motor rooms	58
6.4.6	Generator/UPS rooms	59
6.4.7	Storerooms	59
	Appendix 1 – Lighting for planting	60
	Glossary	63
	References	71
	Bibliography	72
	Index	74

1 Introduction

It is a great misconception to think that most offices are in large modern self-contained blocks or even 'sky-scrapers'. In fact, most offices occur in parts of other buildings such as factories, hospitals or libraries or are small collections of rooms above shops. Wherever the office and whatever its size, it deserves to be lit well. Whether a lawyer's office is on the 20th floor of Canary Wharf, central London, or above the local butcher's shop, it needs to have the best lighting for the tasks that the lawyer needs to perform.

The other misconception is that office lighting is all about creating a uniform lighting level across the whole space. What is needed is uniform lighting across each task area, which normally consists of relatively small areas on each desk. The lighting in the wider office space can, and indeed should, vary somewhat to create visual interest. Even the most dedicated office worker looks up from his or her work from time to time, and when they do they need to see an interestingly lit office space and, ideally, a more distant view out of a window.

If the building and the visual requirements of the users of an office space are understood, and all possible lighting options are considered, a lit environment can be created for each office space that not only provides the required levels of lighting for each task but also provides an interesting and stimulating lit environment for people to work in.

2 Design process

There are many ways to light an office space: with direct light down from above, from indirect light bounced from the ceiling, or from a combination of both. Many factors will dictate or influence the choice of which technique to use. Low ceiling heights or exposed building structure may rule out certain methods or dictate certain layouts. Other building services, such as chilled beams or exposed ductwork, may prevent indirect lighting or provide ideal mounting locations for certain types of lighting. The client, interior designer or architect may have strong views on the style of lighting or lit effect that needs to be created.

For most sizes of office building, the design may be for a known user or a speculative developer and may be a refurbishment or new-build. Section 3 on the 'Design brief and information' outlines the design process for each to ensure that one has defined the brief, compiled information and considered the needs of the users in relation to the physical restraints of each building type and the needs of the owner or developer.

Once the building and its constraints on the design are understood, it is necessary to select the correct task illuminances for the tasks in each area and to consider the effects of room décor on the lighting and the visual appearance of each space. It is then necessary to review the sections dealing with 'Designing with electric lighting' (section 4) and on 'Designing with daylight' (section 5) in order to provide the required illuminances for each task.

The office accommodation being dealt with may not be in a large self-contained office building but rather in a smaller office that may be above shops or part of industrial buildings. It could even be a series of office modules in shared office accommodation or some of the numerous areas where office work is carried out in many other types of building, such as the administrative departments in a hospital, a quality control office on a factory floor or a process control room. The section on building types (section 6) outlines some of the special considerations for each of these office accommodation types.

The need for emergency lighting has to be assessed for any office building. This means standby lighting, safety lighting and escape lighting (for definitions of terms used, see the Glossary). The client should be asked if there is any requirement for standby lighting so that all or part of the office building can continue to function, if only at a reduced level, during power failures. If so, the circuitry or control system for the lighting will need to be arranged so that all or part of it can be supplied from a standby generator or an uninterruptible power supply (UPS) system. If only part of the lighting is to be supplied, then careful thought has to be given as to how the circuitry is arranged. If, say, half of the lighting is to be sup-

1 Introduction

It is a great misconception to think that most offices are in large modern self-contained blocks or even 'sky-scrapers'. In fact, most offices occur in parts of other buildings such as factories, hospitals or libraries or are small collections of rooms above shops. Wherever the office and whatever its size, it deserves to be lit well. Whether a lawyer's office is on the 20th floor of Canary Wharf, central London, or above the local butcher's shop, it needs to have the best lighting for the tasks that the lawyer needs to perform.

The other misconception is that office lighting is all about creating a uniform lighting level across the whole space. What is needed is uniform lighting across each task area, which normally consists of relatively small areas on each desk. The lighting in the wider office space can, and indeed should, vary somewhat to create visual interest. Even the most dedicated office worker looks up from his or her work from time to time, and when they do they need to see an interestingly lit office space and, ideally, a more distant view out of a window.

If the building and the visual requirements of the users of an office space are understood, and all possible lighting options are considered, a lit environment can be created for each office space that not only provides the required levels of lighting for each task but also provides an interesting and stimulating lit environment for people to work in.

2 Design process

There are many ways to light an office space: with direct light down from above, from indirect light bounced from the ceiling, or from a combination of both. Many factors will dictate or influence the choice of which technique to use. Low ceiling heights or exposed building structure may rule out certain methods or dictate certain layouts. Other building services, such as chilled beams or exposed ductwork, may prevent indirect lighting or provide ideal mounting locations for certain types of lighting. The client, interior designer or architect may have strong views on the style of lighting or lit effect that needs to be created.

For most sizes of office building, the design may be for a known user or a speculative developer and may be a refurbishment or new-build. Section 3 on the 'Design brief and information' outlines the design process for each to ensure that one has defined the brief, compiled information and considered the needs of the users in relation to the physical restraints of each building type and the needs of the owner or developer.

Once the building and its constraints on the design are understood, it is necessary to select the correct task illuminances for the tasks in each area and to consider the effects of room décor on the lighting and the visual appearance of each space. It is then necessary to review the sections dealing with 'Designing with electric lighting' (section 4) and on 'Designing with daylight' (section 5) in order to provide the required illuminances for each task.

The office accommodation being dealt with may not be in a large self-contained office building but rather in a smaller office that may be above shops or part of industrial buildings. It could even be a series of office modules in shared office accommodation or some of the numerous areas where office work is carried out in many other types of building, such as the administrative departments in a hospital, a quality control office on a factory floor or a process control room. The section on building types (section 6) outlines some of the special considerations for each of these office accommodation types.

The need for emergency lighting has to be assessed for any office building. This means standby lighting, safety lighting and escape lighting (for definitions of terms used, see the Glossary). The client should be asked if there is any requirement for standby lighting so that all or part of the office building can continue to function, if only at a reduced level, during power failures. If so, the circuitry or control system for the lighting will need to be arranged so that all or part of it can be supplied from a standby generator or an uninterruptible power supply (UPS) system. If only part of the lighting is to be supplied, then careful thought has to be given as to how the circuitry is arranged. If, say, half of the lighting is to be sup-

plied via a generator, then either half the lamps in the luminaires or half the luminaires need to come on. Luminaires can be supplied with twin terminal blocks so that the lamps inside can be supplied half and half or one-third/two-thirds depending on the number of lamps inside. This is more expensive and requires provision of two sets of wiring to all luminaires. It does, however, ensure that the uniformity of the lighting is maintained across the space. The alternative is to arrange the wiring to the luminaires in a chequer-board arrangement so that every other luminaire comes on, like the white squares on a chessboard. This is less costly but leads to poorer uniformity across the space. Where there is an automatic lighting control system, this can usually be configured to turn off some lamps in each luminaire, where the appropriate ballasts have been provided, or to turn off some of the luminaires, during a power failure. This approach gives maximum flexibility as the ratio of standby lighting provided can be varied from department to department depending on the criticality of their function.

Safety lighting needs to be provided where processes have to be shut down or made safe in the event of a power failure or where there is moving machinery. In most office buildings, this is likely only to apply to a print room and some of the kitchen areas. Escape lighting will need to be provided throughout the office space to allow the orderly evacuation of the building in the event of an emergency or power failure. Medium to large buildings usually warrant the installation of a central battery system. This means that one or more secure, ventilated rooms have to be provided in the building to house the battery/inverter units. Refer to Lighting Guide 12: *Emergency lighting design guide*⁽¹⁾ for more advice on safety and escape lighting.

For those seeking advice on a specific room type, Section 6 of this Guide gives detailed design notes on individual room types which one is likely to find in an office building. These are grouped under two main headings: primary office spaces, which include areas such as open-plan, deep-plan and cellular offices; and secondary spaces, which include archives, tea points and meeting rooms. There are also two sections that cover the vital circulations spaces, such as corridors, stairs and lift lobbies and back-of-house areas, such as plant rooms and storerooms.

3 Design brief and information

This section looks at the client types that a designer is likely to be working for and outlines, for each, the process necessary to establish the brief and collect design information so that a high-quality visual environment can be created for the intended users of the areas where office-work will be carried out.

In addition to determining the various office tasks that need lighting, the designer needs to consider what additional feature lighting is required for each building. This can be as simple as an extra spot light on each floor to highlight notice boards or art work or as complex as programmed colour light displays in the atrium. The external lighting of the building can be most important in establishing the client's building's presence on the high street or community. Signage, security, pedestrian access and car park lighting must all be considered in the light of the building's usage and periods of operation.

3.1 Client/user types

The number of combinations of actual client and eventual end user is large, and all affect the design process in different ways. A client wanting a new office block built with the specific needs of his/her existing workforce in mind will have a slightly different perspective to an entrepreneur wanting an office block created for a new venture where the workforce and indeed the whole company structure is yet to be formed. A speculative developer may not have a clear idea of the sort of tenant that will eventually occupy the office building.

3.1.1 New installations for a known user

Where designers are involved with new office space for a specific client, then it is important that they liaise with the client to determine the types of tasks that will be carried out in each area of the building. The needs of a publisher, where many people have to carry out varied and sustained reading tasks, are very dif-

plied via a generator, then either half the lamps in the luminaires or half the luminaires need to come on. Luminaires can be supplied with twin terminal blocks so that the lamps inside can be supplied half and half or one-third/two-thirds depending on the number of lamps inside. This is more expensive and requires provision of two sets of wiring to all luminaires. It does, however, ensure that the uniformity of the lighting is maintained across the space. The alternative is to arrange the wiring to the luminaires in a chequer-board arrangement so that every other luminaire comes on, like the white squares on a chessboard. This is less costly but leads to poorer uniformity across the space. Where there is an automatic lighting control system, this can usually be configured to turn off some lamps in each luminaire, where the appropriate ballasts have been provided, or to turn off some of the luminaires, during a power failure. This approach gives maximum flexibility as the ratio of standby lighting provided can be varied from department to department depending on the criticality of their function.

Safety lighting needs to be provided where processes have to be shut down or made safe in the event of a power failure or where there is moving machinery. In most office buildings, this is likely only to apply to a print room and some of the kitchen areas. Escape lighting will need to be provided throughout the office space to allow the orderly evacuation of the building in the event of an emergency or power failure. Medium to large buildings usually warrant the installation of a central battery system. This means that one or more secure, ventilated rooms have to be provided in the building to house the battery/inverter units. Refer to Lighting Guide 12: *Emergency lighting design guide*⁽¹⁾ for more advice on safety and escape lighting.

For those seeking advice on a specific room type, Section 6 of this Guide gives detailed design notes on individual room types which one is likely to find in an office building. These are grouped under two main headings: primary office spaces, which include areas such as open-plan, deep-plan and cellular offices; and secondary spaces, which include archives, tea points and meeting rooms. There are also two sections that cover the vital circulations spaces, such as corridors, stairs and lift lobbies and back-of-house areas, such as plant rooms and storerooms.

3 Design brief and information

This section looks at the client types that a designer is likely to be working for and outlines, for each, the process necessary to establish the brief and collect design information so that a high-quality visual environment can be created for the intended users of the areas where office-work will be carried out.

In addition to determining the various office tasks that need lighting, the designer needs to consider what additional feature lighting is required for each building. This can be as simple as an extra spot light on each floor to highlight notice boards or art work or as complex as programmed colour light displays in the atrium. The external lighting of the building can be most important in establishing the client's building's presence on the high street or community. Signage, security, pedestrian access and car park lighting must all be considered in the light of the building's usage and periods of operation.

3.1 Client/user types

The number of combinations of actual client and eventual end user is large, and all affect the design process in different ways. A client wanting a new office block built with the specific needs of his/her existing workforce in mind will have a slightly different perspective to an entrepreneur wanting an office block created for a new venture where the workforce and indeed the whole company structure is yet to be formed. A speculative developer may not have a clear idea of the sort of tenant that will eventually occupy the office building.

3.1.1 New installations for a known user

Where designers are involved with new office space for a specific client, then it is important that they liaise with the client to determine the types of tasks that will be carried out in each area of the building. The needs of a publisher, where many people have to carry out varied and sustained reading tasks, are very dif-

Figure 1 Hot desking area within a modern office building



ferent from those of a recruitment agency where there may be a lot of face-to-face interviewing and little paperwork. It is also important to establish what display screen equipment is to be used, where it is to be installed and the way the users intend working with the equipment.

The best way to get a feel for the tasks and the way a company operates is often to visit the user's existing premises. This usually provides valuable insights into the tasks, equipment and working practices of the departments and the staff in them. If, however, the user is a new start-up company or is moving into a new area of operations, it may not have similar existing office space. In this case, it may be possible to find premises where similar tasks, equipment or operating methods are used.

It is also important to establish with the user the type of interior décor that they prefer or are likely to choose. This will ensure that likely surface reflectances can be taken into account in preliminary lighting calculations. It is often easier with a known user to confirm what window-screening techniques are to be used and to confirm that office layouts are compatible with the intended lighting solution. With a specific end user of an office building, it is usually easier to define any non-task or decorative lighting required. This can be lighting for artworks, feature lighting or external lighting of the building.

Some companies have very static furniture layouts over time, and fairly fixed patterns of employment. This means that a fixed layout of lighting, either general or localised, can be effective. Others companies have a need for rapidly changing work teams or even areas for hot-desking, where staff do not have a permanent desk but claim a desk only when in the office. Here reduced background lighting with re-locatable task lighting may be more effective. Also, local control of lighting is likely to be more important in such areas (see Figure 1). For areas where there will be re-locatable walls, the lighting levels need to be

3.1.2 Speculative space for an unknown user



Figure 2 Unoccupied open-plan office space

related to the likely sizes of the partitioned offices, since, for a fixed layout of luminaires, the smaller the office module the lower the resulting lighting levels will be. See section 3.3.3 'The effect of re-locatable walls on lighting levels' for more information.

The lighting design may be for a known user intending to fit-out a space within a speculative office building. The building may have been left with just central power supplies up to distribution boards in risers on each floor, or have been partly fitted out with 'landlord's' lighting of lift lobbies and even primary circulation space on each floor. The designer of the lighting for the fit-out will need to liaise with the designers of the landlord's services and lighting to establish what provision has been left for the fit-out.

For designers of speculative office space where the working spaces are usually flexible and not designed for specific users or tasks, a more general lighting approach is needed. The end-users could be carrying out almost any type of task or bring in any old type of display screen. For this reason, the exact nature of the lighting and decor to be provided must be established with the building's owner or developer.

For almost all speculative buildings, the owner is likely to require the design of all shared building lighting such as that in reception, stairs, lobbies etc. In some buildings the landlord's lighting may be extended to primary circulation space on each floor. The tenants are often just provided with central power supplies up to distribution boards in risers on each floor for their future lighting. The designer needs to consider how far to go in allowing flexibility for future tenants' lighting. To provide too much flexibility in the way of distribution board size or control provision may incur unnecessary costs for the landlord. To provide too little flexibility may make the building less desirable to potential tenants (see Figure 2).

There are a number of standard terms for the degree of provision within a speculative building. A 'shell & core' office includes finishes and fit out to landlord areas only, with services capped off within the riser at each floor and office areas left as a structural shell. 'Category A fit out' extends finishes and services into office areas to create usable open plan space. 'Category B fit out' provides all services to the tenant's requirements.

Before starting the design process for any tenanted floor space, it is important to establish with the building owners, and possibly the letting agent, the types of user to which the space will be marketed. Designing the lighting for moderate use of basic applications on general display screens when the developer is trying to sell the space as suitable for high-intensity dealing activity can lead to serious problems for all concerned.

The letting options will affect the choice of lighting strategy. Perhaps it would be judged acceptable to just put in a general background lighting system giving, say, 300 lux with any higher task lighting levels being provided by the future tenant by means of task lighting. It is also important to agree whether controls are to be included, the required degree of adaptability of the lighting and the lighting levels that are to be achieved.

The space planning flexibility also needs to be established. This will help to determine the likely effect of partitioning options on both the illuminances and cut-off given by the partitions to long views of luminaires across the space. Most speculative space is marketed as totally open-plan with likely partitioning options indicated. The lighting design will need to take into account these possible partition arrangements and allow for suitable task lighting levels and uniformities in a range of cellular office modules from a fixed lighting grid (see 3.3.3 'The effect of re-locatable walls on lighting levels' for more information).

It is important to liaise with the architect or interior designer on finishes and window types and their screening. Once these points and the possible partition layouts are established, lighting design philosophies can be established that will allow the correct degree of flexibility in letting options. However, not all possi-

bilities can be catered for. For example, it is possible that what was intended as small factory start-up units may end up being let to a high-tech computer-based user. Putting in lighting that can cope with too wide a range of possible users may be very expensive or be a poor compromise for all users. Adaptable design options, and their costs, should be explored with the building owner.

3.2 Building types

Buildings that contain office space vary in size and complexity from large corporate headquarters through smaller, local office buildings. These self-contained office buildings are likely to have a distinct image and contain most types of office space and related support facilities. Far more common are smaller offices that may be in a small building or above shops or part of industrial buildings. These contain most of the typical types of office space but some support functions may be missing. There are also office modules in shared office accommodation which vary in complexity from spare space rented out in an office building to purpose designed office 'villages' or shared resource space in old converted industrial buildings. There are many areas where office work is carried out in other sorts of building such as the quality control office on a factory floor or in a process control room.

Whatever type of building is being designed, it is necessary for the designer to gain an understanding of the range of tasks that will be carried out and the types of spaces that are needed in the building so that appropriate lighting can be designed. Once the style of building and the degree of flexibility required of it have been established, the designer needs to consider the illuminance required for each task and the effects that the room décor will have on the lighting. Where there are moveable or re-locatable walls or partitions, the effect of these on the lighting also needs to be considered (see 3.3.3 'The effect of re-locatable walls on lighting levels' for more information).

3.2.1 Self-contained office buildings

The larger purpose built office building is normally designed with the full range of secondary office spaces as well as the main working office spaces. These secondary areas may be adapted parts of the offices space or specially created rooms. These spaces, such as meeting rooms, reprographics, resources areas and atria spaces, play an important role in the efficient running of the office and should be well lit.

Often the self-contained office building is built to impress, with high-quality entrance, reception and lift areas. The lighting design and the resulting visual environment need to help this goal to be achieved. The quality of the luminaires themselves, in terms of build quality and surface finish, needs to be considered. Feature luminaires may be required in entrance halls and lobbies. Special lighting effects such as colour washes, fixed or moving logos and framing or highlighting of artwork or special features may be required.

3.2.2 Smaller offices

The majority of offices are small units above shops, converted houses or in small units on business or industrial estates. These buildings tend to have more cellular office space and are generally less adaptable. Owing to the lack of scale in the building, many of the usual office functions are combined in single rooms. Thus the photocopying may be carried out in the corner of the reception area or the meeting room may be a part-time office. Often the lighting designer has to take account of such problems in deciding the type and style of lighting for each space.

Many historic buildings are used as offices. In a city such as Bath, many Georgian houses in the city centre have been converted for use as offices. This includes grade I listed properties in prominent positions as well as the more run-of-the-mill old properties. For most of these, where the interiors have been fitted out to modern standards, the lighting can also be fairly straightforward modern styles. Sometimes there will be the need to take into account unusual ceiling heights or make allowances for careful routing of wiring through the building (see Figure 5).

With many listed properties, not only has the interior lighting got to fit in with the interior style of the house but it must also not spoil the view into the property from the outside. Looking up at a grand Victorian façade and seeing fluorescent lights on chain suspensions or brightly coloured luminaires inside may be somewhat disconcerting.

In some circumstances, it would be appropriate to specify chandeliers with incandescent lamps for, say, the principal first floor rooms of a listed Georgian house. These will be visible from the street and would appear correct for such grand rooms. It is likely that task lighting would be needed to provide necessary lighting on desks. The use of potentially bright chandeliers in rooms where display screens are in use needs particular care, although the relatively small rooms give a user–screen–light geometry that means that reflections in screens are unlikely.

3.2.3 Shared office space

Many small organisations share office facilities in a single building. Each company has its own office space in one or more rooms and then draws on the common centrally owned facilities as and when required. Such serviced office accommodation has the advantage for small companies that they have to pay only for central services such as copying, reception, meeting rooms and sometimes restaurant facilities without the initial investment in space, furniture and staff. These building can vary from the ‘posh’ Mayfair serviced offices, where users can impress their clients by renting an office space or meeting room for a day, to thriving communities of designers and artists in converted factories with simple finishes and services. The lighting design needs to reflect these differences (see Figure 3).

Figure 3 Partitioned areas in serviced office space



For the lighting designer there is the need to provide adaptable lighting in the office modules so that an individual company can adapt the lighting in a changing number of rooms or spaces to their specific needs. Often, a start-up company will have one large office room and then, if the business takes off, will rent extra rooms. Some companies with specific lighting needs may need to adapt the lighting of each room as they take it over. As the new rented rooms are often scattered over the building, because neighbouring rooms have been rented to other companies, at some point the company may agree with the landlord

to move all its operations to one suit of adjoining rooms if they become available as other companies fail and move out. This constant flux within the building means that the lighting has to be adaptable.

For the common areas, the lighting can be fairly standard for such spaces – with the observation that these spaces cater for a constantly changing work force with many different needs. Within many of the larger office buildings one is likely to find most of the primary types of office space, such as open-plan and cellular offices, typical secondary spaces, such as tea points and meeting rooms, circulations spaces and the back-of-house areas, such as plant rooms and store rooms.

3.2.4 Areas where office work is carried out within other building types

Almost all buildings have small spaces where office work is carried out. The small local garage will have an office in the corner where the books will be done and often tea will be drunk and newspapers read. Factories have production and quality control offices on the shop floor and, perhaps, accounts, finance and personnel offices alongside the production areas. Someone using a display screen in a small production office in the midst of some assembly lines deserves the same quality of lighting as the chairman's secretary. Realising this ideal is not always easy.

Small offices on the factory floor are often self-contained boxes to provide some degree of privacy and sound insulation (Figure 4). In these cases, lighting can usually be provided in the normal way in or on the ceiling, boosted by local task lighting as appropriate. Where the office tasks are provided in partitioned-off areas it may be necessary to provide just extra task lighting on or by desks to supplement the overall lighting of the factory floor.

Figure 4 Office within an industrial production area



3.2.5 Refurbished buildings

Many offices are created from refurbished buildings. They may have been offices already and are merely being upgraded or they may have been barns, shops, stately homes or factories. Each old building normally has a set of physical restrictions that, although a challenge, offer great scope for innovative and interesting lighting. Often an old building, especially one with large or unusual architectural features, can be very visually interesting when well lit.



Figure 5 Converted church interior

The first type of refurbished building to be considered is where an existing building is converted from some other purpose to create an office. There are many examples of old warehouses, factories and breweries being converted to form new office accommodation. In such conversions there are likely to be more physical restraints on the design than with a new building. It is necessary to check whether the building, its internal features or even the area surrounding it are listed. If it is, Listed Building Consent may be needed for any material changes or additions to the building. If it is in a Conservation Area there may also be constraints. There are also likely to be unusual problems in terms of room shapes or heights and unusual wall surfaces or physical obstructions to the light that need to be considered carefully (see Figure 5). At least fairly accurate assessments of existing surface reflectances can be made for use within the calculations for the new lighting. See the SLL Lighting Guide 11: *Surface Reflectance And Colour* which contains useful colour panels for assessing the reflectance of existing wall surfaces.⁽²⁾

Figure 6 Offices in refurbished building using different lighting styles leads to a poor external appearance



The other form of refurbishment is where an existing office building is in need of an update or where there is a change of use of the area or building or because of a new tenant or department moving into the space. These refurbishments can vary from a simple replacement of old or inefficient lighting to the complete strip-outs of existing servicing right back to the structure. Whatever the reason for the changes, the new lighting should create an appropriate visual environment and provide the necessary task illuminance in an efficient manner (see Figure 6).

The refurbishment may be purely of the lighting itself or may be a more extensive refurbishment of the ceiling system and related services. Where only the lighting is to be refurbished, there is always the temptation to retain the cabling to existing lighting points. Where it suits the new lighting arrangement, of course, existing wiring that is still safe to re-use should be used. However, it is important that the existing wiring points do not drive the designers to compromise the lighting arrangement. It should be remembered that if the luminaires are changed or the wiring altered then the lighting in the refurbished area will need to comply with the energy limits set out in the Building Regulations (*Approved Document L2*, due to be updated in 2005).⁽³⁾

With a proposed refurbishment of an existing office space there is often a chance to assess the needs of existing display screen users. Sometimes the refurbishment of the lighting has arisen after a detailed assessment of the lighting needs of these display screen users. Such an assessment will have amassed a great deal of information on the screens in use and the ways the users are operating them, which can be used in the preparation of the design.

There may be a suggestion that the existing luminaires should be converted, perhaps to become more 'suitable' for display screen use. While this may be

thought to be cheaper than purchasing new luminaires, there are possible pitfalls to be considered, including electrical or mechanical dangers inherent in a poor conversion, change of thermal characteristics of the luminaires leading to changes in light output of the lamps and changes to the uniformity of the resultant illumination on the working plane.

With an existing space there is also the opportunity to examine the existing windows and their screening systems. If they are sufficient to provide attenuation of bright sky areas; are opaque enough not to be over bright in sunlight; and are easily adjustable by the users of that space, then they may well be suitable for retention. If not, new window shading is likely to be required.

3.3 Design criteria

Once the designer understands what limitations the building puts on the design, he/she will need to consider what recommended task illuminances to use for each task area. Then the effects of the décor and surface reflectance in each area will need to be taken into account. Unless these are defined in a brief, the designer should confirm to the client the lighting levels being used for the design and any assumptions being made about surface reflectances or maintenance cycles.

3.3.1 Selection of illuminance

The recommended design maintained illuminance over the task area in any room where office work is carried out is generally in the range 300 to 500 lux. This range allows some scope for tailoring for the exact type of work being carried out in the space. Where the tasks are mainly screen based, such as data retrieval or telephone sales, then illuminances at the lower end of this range should be used. Where the tasks are mainly document based, such as writing or copy typing, then 500 lux will be required. Where there are visually more onerous tasks, such as proof reading or technical drawing, even higher levels should be considered. Where the task is of short duration or is unusually large or of high contrast, a reduction in illumination level may be possible (see section 2.3.2 of the *Code for Lighting*).⁽⁴⁾ The minimum level set by the Health and Safety Executive for any permanently occupied area is 200 lux.⁽⁵⁾ Areas that are not continuously occupied, such as circulation spaces, do not need to have this level.

The amount of light available from any lighting system is affected by the room décor and surface reflectances. If details of the room surface colours and reflectances are available from the architect or interior designer, then these should be used; otherwise, the assumptions used in the design should be confirmed to the client. To maintain colour fidelity in any office interior, the lamps used should all have a colour rendering index of Ra80 or above.

The ways of achieving the desired lighting levels are discussed in section 4 'Design options for electric lighting'. Note that, in open spaces that are to be partitioned, the lighting level would be lower in the partitioned spaces compared with that in the open space. See section 3.3.3 'The effect of re-locatable walls on lighting levels' for more information. Section 6 'Detailed room design information' describes various room types and areas likely to be found in offices. The *Code for Lighting's* full 'Schedule of recommended illuminances' gives details of many other room and task types that may be found in some specialist offices.⁽⁴⁾

With indirect lighting, direct lighting or direct/indirect lighting, it is possible either to provide all the required illumination or to provide just background lighting of, say, 200 lux, supplemented with good task lighting. This task lighting may be desk-, furniture- or partition-mounted. Local task lighting can present problems in terms of electrical supply, safety and positioning but does allow for local switching or dimming and perhaps adjustment of light direction. This gives users greater control over their environment, which usually leads to increased user satisfaction. It is also possible in some spaces to provide localised lighting just over or around clusters of desks. Either of these techniques generally leads to significant energy saving.

The use of area or individual dimming of the luminaires should be considered. This will allow users to reduce the lighting level if they prefer to do so. It can also allow for reductions in electric lighting at times and in areas where

there is sufficient natural light. It should be checked that one user's reduction in his/her lighting level does not adversely affect the lighting level in adjacent workspaces where users may prefer a higher lighting level. See section 4.5 'Controls' for more information.

There are other recommendations in the *Code for Lighting* on limiting glare index, colour rendering, uniformity and energy limits for the lighting of many of the environments where office work may be carried out such as factories, libraries, hospitals etc.⁽⁴⁾

3.3.2 Room décor and surface reflectance

The recommended ranges for room surface reflectance and illuminance are shown in Figure 7. Depending on the type of lighting system (direct, indirect etc), each surface reflectance and relative wall illuminance should be chosen to provide the best overall visual environment for the space. Although the lighting cannot always override other considerations in the choice of room décor, the needs of the lighting and visual environment must be brought to the attention of the architect or interior designer.

Figure 7 Relative illuminances from a ceiling-mounted direct general lighting scheme for the main surfaces in a commercial working interior with suggested reflectances

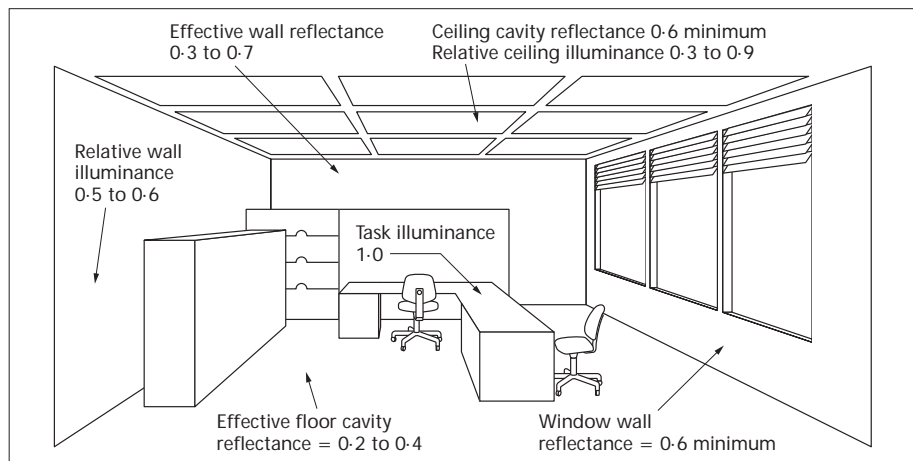

When assessing the average surface reflectance of a space, all areas need to be taken into account. For instance, large windows without blinds or loaded bookcases will lower the wall reflectance. Even a door of a different colour can affect the average in a small room. As a guide, see Table 1. However, the diffuse reflectance of building materials covers a very wide range and the designer is advised to seek out as accurate a value as is possible. For example, bricks can vary anywhere between 0.2 and 0.7, while timber is likely to fall between 0.1 and 0.4. Textured surfaces such as carpets will generally have a relatively low reflectance unless they are very light in colour. Painted surfaces will also vary widely. For example, a white emulsion painted plaster surface could have a reflectance as high as 0.8 while a dark painted surface could be as low as 0.1. The diffuse reflectance of some materials, such as paints, can often be obtained from the manufacturer. However, if manufacturers' data are not available, one of the methods described in Lighting Guide 11: *Surface reflectance and colour*⁽²⁾ should be used. For major surfaces on important projects, actual samples could be assessed; this should be under the illuminant to be used on the project.

The wall illuminances need to be considered to ensure that the walls do not appear dark in relation to the working plane. With direct lighting, there is a danger of the upper walls appearing dark. In certain spaces, wall washing may be needed. To achieve a good luminance balance in a space, the average wall illuminance above the working plane, from both the direct and reflected components, should be at least 50% of the average horizontal illuminance on the working plane. (No one wall should be less than about 30%.) Where these walls may be seen reflected in any display screens, care must be taken to avoid bright scallops or patches (luminance greater than 1500 cd/m²) appearing on the walls, i.e. gradual changes in illuminance will be necessary on these walls.

Table 1 Reflectances of common building finishes

Materials used internally	Reflectance	Paint colours (with BS 4800 colour code) ⁽⁶⁾	Reflectance
White paper	0.8	White 00E55	0.85
Stainless steel	0.4	Pale cream 10C31	0.81
Cement screed	0.4	Light grey 00A01	0.68
Carpet (cream)	0.35	Strong yellow 10E53	0.64
Wood (light veneers)	0.4	Mid-grey 00A05	0.45
Wood (medium colours)	0.2	Strong green 14E53	0.22
Wood (dark oak)	0.1	Strong red 04E53	0.18
Quarry tiles	0.1	Strong blue 18E53	0.15
Window glass	0.1	Dark grey 10A11	0.14
Carpet (deep colours)	0.1	Dark brown 08C39	0.10
		Dark red-purple 02C39	0.10
		Black 00E53	0.05



Figure 8 Colour patches on the ceiling caused by reflections from strongly coloured floor and furniture surfaces

With direct lighting schemes, most of the light flows downwards to light the floor and working surfaces and leaves the ceiling and sometimes the walls looking relatively dark. In such schemes, a relatively high floor cavity reflectance and to a lesser degree, wall reflectance will ensure that light is reflected back up onto the ceiling to avoid an oppressive atmosphere. However, note that it is difficult to achieve and maintain an effective floor cavity reflectance of more than 20% due to light absorption under desks and between furniture and the steady degrading of light floor finishes.

For the ceiling not to appear dark, the average illuminance on the ceiling, from both the direct and reflected components, should be at least 30% of the average horizontal illuminance across the working plane.

In large spaces with ceilings less than 2.4 m high this may be hard to achieve. If there is no alternative to using recessed luminaires, the ceiling illuminance ratio should still be as close to 30% as possible.

It is likely that where ceiling illuminance ratios are lower than 30% a poor visual environment will result.

Where reflected light is not sufficient to achieve these levels, additional light from the sides of surface-mounted downlights; from uplighting elements of suspended luminaires; from dropped elements of recessed downlights or from supplementary uplights may be needed.

A variety of light colour finishes in the interior can be beneficial, as it helps to avoid a gloomy appearance due to the relatively low vertical illumination on walls. Highly coloured desk or carpet finishes will result in colour patches being reflected back up onto the ceiling; this can be good or bad depending on the colours and type of interior (see Figures 8 and 9).

Figure 9 Comparison between direct and combined lighting – note darker ceiling on left with green tinge from reflected light from carpet



For indirect lighting schemes the emphasis should be placed on achieving a high ceiling cavity reflectance and, to a lesser degree, upper-wall reflectance. This is to ensure greater indirect lighting from this plane as it is the only one directly lit. The intent must be to allow as much inter-reflected light as possible back from the ceiling to maintain efficiency. To avoid any colour casts in the room, the ceiling cavity surfaces should not be coloured. A variety of colour finishes in the rest of the interior is to be encouraged as it helps to counteract indirect lighting's tendency to be bland and monotonous.

With combined direct/indirect systems, there is again a need to have a relatively high ceiling-cavity reflectance to ensure that a reasonable amount of soft indirect light arrives back down from the ceiling. There is less reason to aim for a high floor-cavity reflectance as the ceiling is already directly lit.

3.3.3 The effect of re-locatable walls on lighting levels

The lighting level provided by a given grid of luminaires varies depending on the size of the room they are lighting. In a completely open-plan space, a point in the room receives light from many luminaires. If a wall is put up, light from some luminaires is cut out and replaced by a small amount of light reflected back from the wall. With a fairly narrow light distribution from the luminaires, this effect will be minimised but with a wide distribution the effect of partitions will be greater. The amount of light reflected back from the partitions also depends on the reflectance of the partitions. With glass partitions this effect is less noticeable, although the lights in the adjoining office could be off and therefore not contributing any light through the partition (see Figure 10).

Figure 10 Glass screens allow light into office space and views out



Figure 11 shows an open plan office with three cellular offices. The proportion of luminaires to office area is the same but, as the spaces gets smaller from A to D, the Room Index decreases and so the utilisation factor decreases. In this example, the lighting level in the large open-plan space A is 400 lux, in the large office B it is 380 lux, in the medium office C it is 350 lux and in the small office D it is just 310 lux.

Obviously, if the designer is to meet the required task lighting level in any possible office space he/she needs to know the size of the smallest practicable office. If the required lighting level can be met in the smallest module then,

Figure 11 Open plan office with three cellular offices showing influence of luminaire layout

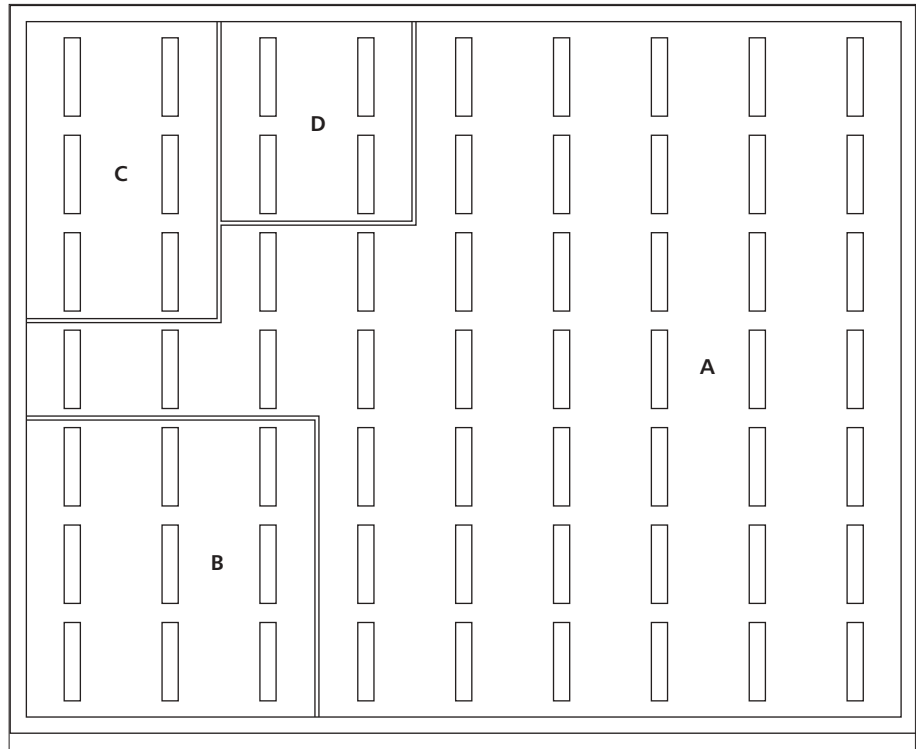
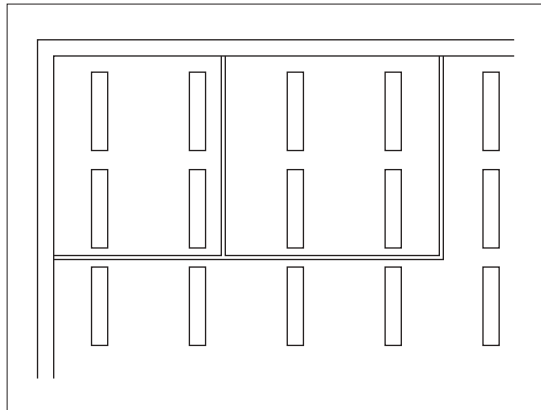

Figure 12 Wall too close to a row of luminaires, adversely affecting light distribution



assuming that the ratio of lights to floor area remains the same, the lighting level in the larger spaces will exceed this amount.

Care needs to be taken if the architect or letting agent asks for partitions to be freely located without regard to luminaire spacing. If the wall is too close to a row of luminaires then not only will there be a bright patch of light on one side of the wall but the lighting level on the other side of the wall will be lower as there will be a greater floor area per luminaire (Figure 12). If there is also the possibility of a partition actually being positioned under a luminaire, there is also the risk of not being able to maintain, clean or re-lamp the luminaire. There will also be sound path over the partition if the luminaire is of the coffer or open louvre style.

Although the above example uses direct lighting, a similar effect is evident when using direct/indirect or indirect lighting. With direct/indirect lighting, the effect of decreasing office size is the same, with a decrease of resulting average illumination in the office. With indirect lighting, the effect is moderated by the method used for indirect lighting. If the indirect lights are designed to be next to desks to provide localised lighting, then the office module size has less effect. If the indirect luminaires are partition mounted, the resulting lighting

level in the office relates roughly to the number of luminaires compared with the office floor area.

With re-locatable walls, the method of controlling the lighting needs careful thought. If each possible cellular office space needs to have its own control over the lights in that office, then a flexible switching system is needed. Such flexibility can be provided by changing the electrical connections from luminaires to switch points in the ceiling, as shown in Figure 13. The limitations of such a system, in terms of the possible configurations, should be apparent. It is also possible to provide a programmable system where each luminaire can be separately addressed and controlled from a central system. Electronic switches or hand-held controllers can then be programmed to control whichever luminaires are required. See the section 4.5 'Controls' for more details.

Figure 13 Flexible lighting controls for a partitioned office space

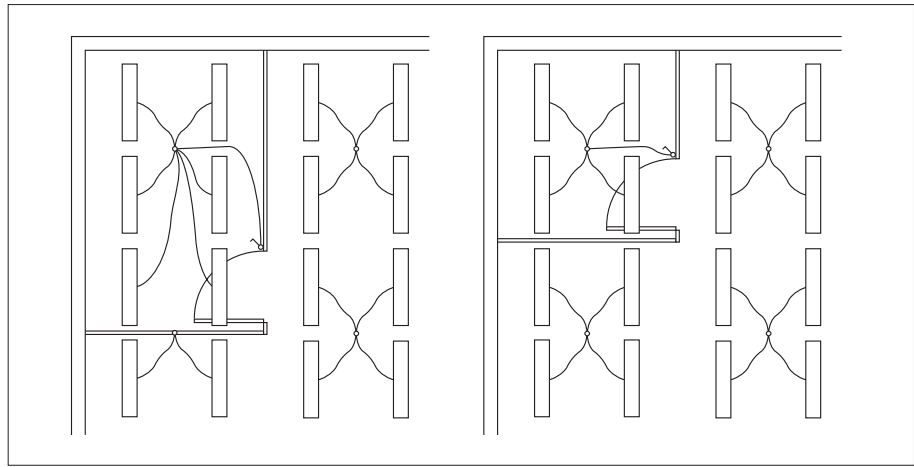

4 Design options for electric lighting

This section looks in detail at the various lighting techniques available to the designer to provide a suitable visual environment for office work. These techniques include:

- lighting directly onto the working plane from luminaires on, or suspended from, the ceiling;
- indirect lighting via the lighting of the ceiling and upper walls by free-standing, furniture-mounted, wall-mounted or suspended indirect lights;
- lighting from combined indirect/direct lights suspended from the ceiling; and
- lighting the task area with local lights combined with one of the above luminaire types providing the general lighting of the space.

The selection of the type of lighting most suitable for the space depends on the physical constraints of the space, the proposed decor, user and designer preferences and capital, energy and maintenance costs. Electric lighting needs to provide the appropriate lighting level for all tasks carried out in the space without causing glare or leading to wide variance in luminance between the various surfaces of the space.

4.1 Preliminary decisions

4.1.1 The physical restrictions of the space

One of the most obvious restrictions when it comes to selecting lighting types is room height. This can vary from as low as 2.1 m to lofty heights of 4–6 m in banking halls or double-height spaces. If the proposed space has a floor-to-ceiling height less than 2.5 m, it is difficult to use indirect lighting successfully without causing bright patches on the ceiling over the luminaires which may appear as images on any display screens in the area. For ceilings below 2.3 m, direct lighting is likely to be the only viable option although even then it is unlikely that a good luminous environment can be provided.

In spaces higher than 2.5 m, floor- or wall-mounted indirect lighting can be considered, as there is sufficient height above the luminaires to allow a wide dis-

level in the office relates roughly to the number of luminaires compared with the office floor area.

With re-locatable walls, the method of controlling the lighting needs careful thought. If each possible cellular office space needs to have its own control over the lights in that office, then a flexible switching system is needed. Such flexibility can be provided by changing the electrical connections from luminaires to switch points in the ceiling, as shown in Figure 13. The limitations of such a system, in terms of the possible configurations, should be apparent. It is also possible to provide a programmable system where each luminaire can be separately addressed and controlled from a central system. Electronic switches or hand-held controllers can then be programmed to control whichever luminaires are required. See the section 4.5 'Controls' for more details.

Figure 13 Flexible lighting controls for a partitioned office space

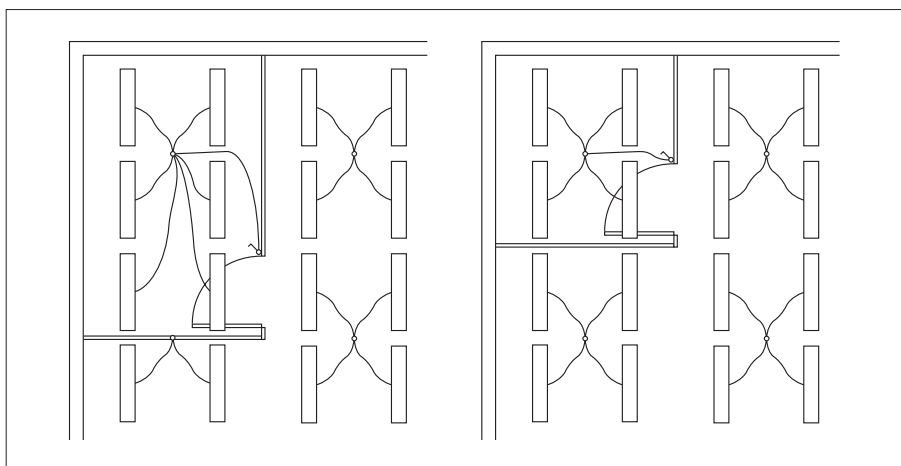

4 Design options for electric lighting

This section looks in detail at the various lighting techniques available to the designer to provide a suitable visual environment for office work. These techniques include:

- lighting directly onto the working plane from luminaires on, or suspended from, the ceiling;
- indirect lighting via the lighting of the ceiling and upper walls by free-standing, furniture-mounted, wall-mounted or suspended indirect lights;
- lighting from combined indirect/direct lights suspended from the ceiling; and
- lighting the task area with local lights combined with one of the above luminaire types providing the general lighting of the space.

The selection of the type of lighting most suitable for the space depends on the physical constraints of the space, the proposed decor, user and designer preferences and capital, energy and maintenance costs. Electric lighting needs to provide the appropriate lighting level for all tasks carried out in the space without causing glare or leading to wide variance in luminance between the various surfaces of the space.

4.1 Preliminary decisions

4.1.1 The physical restrictions of the space

One of the most obvious restrictions when it comes to selecting lighting types is room height. This can vary from as low as 2.1 m to lofty heights of 4–6 m in banking halls or double-height spaces. If the proposed space has a floor-to-ceiling height less than 2.5 m, it is difficult to use indirect lighting successfully without causing bright patches on the ceiling over the luminaires which may appear as images on any display screens in the area. For ceilings below 2.3 m, direct lighting is likely to be the only viable option although even then it is unlikely that a good luminous environment can be provided.

In spaces higher than 2.5 m, floor- or wall-mounted indirect lighting can be considered, as there is sufficient height above the luminaires to allow a wide dis-

tribution of light without over-lighting the area of ceiling directly over them. Suspended indirect lights or indirect/direct luminaires generally need a greater floor-to-ceiling height as the units need to be suspended far enough below the ceiling to provide a good distribution of light across it but be high enough above the floor to avoid being a physical danger or a visual intrusion to those walking or working below.

In all high spaces, the problems of access for re-lamping and maintenance must be considered before using ceiling mounted or suspended luminaires. If adequate maintenance access cannot be provided to high-level lighting, then wall- or column-mounted indirect lights may be more suited although the efficacy will not be high.

4.1.2 Lighting styles

There are many ways of lighting an office space, each with its own advantages and disadvantages. Each also strongly affects the lit appearance of the space and the balance of surface luminances within the space.

Figure 14 shows the main styles of lighting. It progresses from pure direct light down from the ceiling, through various intermediate styles to pure indirect lighting. With purely direct light, the floor and lower walls are well lit but the ceiling and upper walls are not so well lit. This can create a rather gloomy feel to the space. If light is allowed to flow from the direct luminaire onto the ceiling adjacent to it, the ceiling brightness increases. If one installs suspended direct luminaires with some uplight the upper part of the room will be even better lit. Purpose-designed direct/indirect luminaires allow the designer to tailor the flow of light down and up to suit the room and occupants. The combination of direct lights and separate indirect lights is sometimes needed and can provide the same quality of lit environment but usually with a higher capital cost. Using purely indirect light means that the ceiling and upper walls are lit to a higher level than the working plane; this can be distracting in some circumstances and can lead to a rather bland environment.

Figure 14 Six main lighting styles for offices

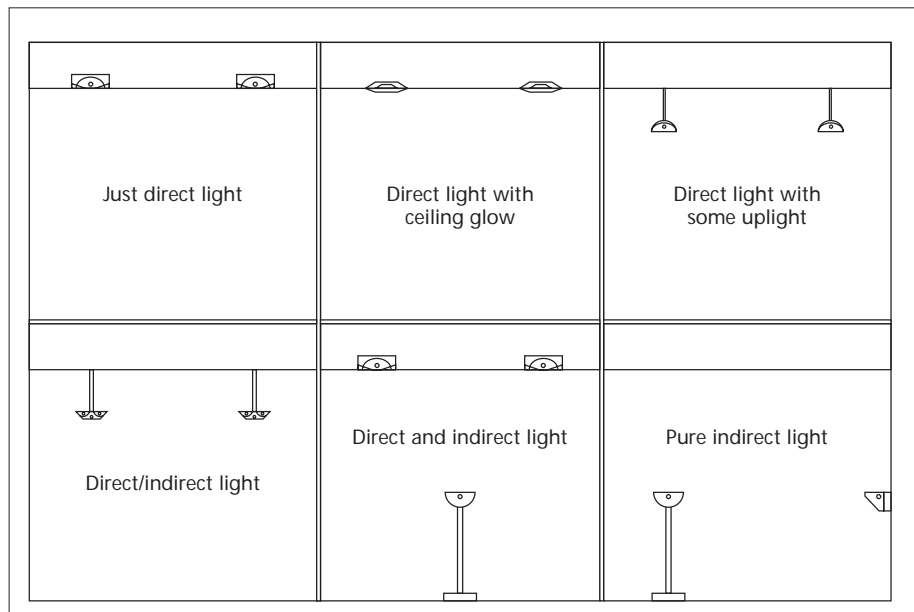

With any style of lighting, the overall visual appearance of a space and the amount of light available from inter-reflection is strongly affected by the room décor and surface reflectance. Figure 9 shows how the direct lights on the left give a low ceiling luminance as the only light reaching the ceiling is the green tinged light reflected back up from the carpet. The right part of the photograph has indirect lighting up onto the ceiling. With every design, the energy usage and the use of controls must be considered so as to minimise running costs and to comply with the Building Regulations.⁽³⁾ There follow more detailed sec-

tions on direct lighting, direct/indirect lighting, a combination of direct and indirect luminaires and indirect lighting that go into far more detail on the design implications for each of these styles.

4.1.3 Services options

Within most interiors, there are aspects of the electrical services, switching and other services that have implications for the lighting options selected. Also, the type of lighting method chosen affects the amount of flexibility available for future changes to the lighting layout and hence the lighting of altered work-space layout.

With freestanding indirect lights, the electrical supply comes from floor level. This means that there are a number of aspects of the electrical system that need to be considered. Because of the relatively high power load, and even higher starting load with discharge lamps, it is recommended that the number of indirect lights that can be plugged into a single circuit be checked. Where personal computers are using the same circuit, data errors may occur when starting the indirect lighting, due to voltage spikes appearing on the circuit. This means that a separate floor power system may be preferred for supplying floor-mounted indirect lights. To avoid other equipment being plugged into these circuits, non-standard plugs and sockets can be used. This arrangement permits central control and switching of the indirect lights but also results in another set of floor services in addition to the normal power, data and telecom services. Where false floors are in use, this may not be a problem but where floor trunking is in use then difficulties may arise due to overcrowding. Floor-supplied indirect lights can, however, be an advantage where they remove the need for lighting supply trunking and conduit in an otherwise congested ceiling void.

The use of ceiling-mounted or suspended luminaires does free the floor, not only of space occupied by additional power supply distribution but also the area occupied by the indirect lighting. The major disadvantage is that, in general, the lighting array is fixed. This tends to make the use of the space less adaptable where full-height partitioning is required unless individual luminaire regulation is used. Where direct lighting luminaires are recessed, they need to be physically co-ordinated with other services in the ceiling. Surface-mounted luminaires can be considered unsightly in certain spaces and may interfere with air distribution across the ceiling from supply air grilles in mechanically ventilated buildings.

Unless a system of track mounting or similar is proposed, then indirect/direct luminaires are as fixed as pure direct lights. There is, however, the possibility of exchanging the luminaire or altering the number of lamps or the ratio of indirect to direct lighting. This can provide a range of task illuminances and introduce some visual variety across large spaces. Freestanding indirect lights, on the other hand, can provide a flexible lighting source, as they can be moved around to suit new office layouts or re-spaced to provide varying illumination levels.

4.1.4 Lighting techniques

With any of the lighting styles it is possible to provide the required task illumination at desk height across the whole space, to provide it locally to groups of desks or to provide just background lighting levels across the space boosted to the required task levels purely where and when needed on the desks. General lighting is perhaps the most flexible, allowing the user to place a desk wherever needed and achieve the required task levels, but it consumes unnecessary amounts of energy in over-lighting circulation routes and ancillary areas of the office. Localised and task lighting techniques are described in detail in the next two sections while sections 4.4 to 4.9 discuss energy, controls and the various general lighting techniques using each of the lighting styles available.

4.2 Designing with localised lighting

Localised lighting is where one or more luminaires are positioned in the vicinity of the task area. This might be by luminaires in, or suspended from, the ceiling above desks, or by freestanding lighting that may be a direct/indirect luminaire placed by a desk or an indirect light placed within a cluster of desks (see Figure 15).

Localised lighting is generally used to provide all the required task lighting on the desk, although it is possible to use local luminaires to provide the top-up

Figure 15 Suspending lights over a desk delivers light just where it is needed



Figure 16 Floor standing dual-component system with soft uplight for background lighting and direct light for task lighting

lighting from a lower ambient level up to the selected task illuminance. This can be an energy efficient way of lighting a space but usually at the cost of additional equipment cost.

Localised lights that are within or fixed to the ceiling are normally part of a re-locatable ceiling-tile system where the individual tile with the luminaire can be exchanged for an adjacent blank tile. Such a system relies on the above-ceiling mechanical services being sparse enough and the wiring system being flexible enough to allow some flexibility in positioning the luminaires.

Suspended local luminaires can also be suspended from a track system. This track can be powered track, as used for spotlighting, or mainly mechanical track with the electrical connections being taken up by 'curly lead' to fixed electrical connection points or sections of powered track. Obviously, the more extensive the track system the more flexible the lighting can be, but at a greater capital cost.

Free-standing localised lights that have a direct component should ideally be positioned so as to throw light from the side of the task area. Ideally, it should be possible to have the light coming from either the left- or right-hand side of the desk, to suit the user. The spread of light should cover, as evenly as possible, the area of desk used for reading written text. Uniformity over the task area should be 0.8 or better (see Figure 16). With some types of free-standing indirect luminaire, the base or central column can provide a position for power and data sockets, allowing easier cable management and flexibility for some desk-system arrangements.

Indirect luminaires can be used as localised lighting by positioning them within a cluster of desks. Then the highest levels of light are across the desks with the light falling off between the clusters. This approach obviously requires integration with the intended furniture plans and the working practices of the office. Figure 17 shows the illuminance contours from a single uplight. Light from neighbouring uplights would boost the levels above those shown.

Figure 17 Illuminance contours for a single uplight

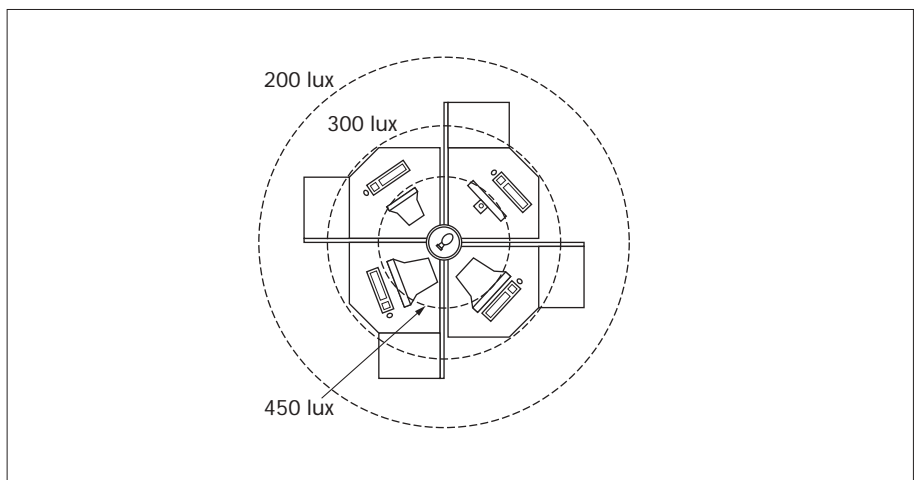

4.3 Designing with supplementary task lighting

Supplementary task lighting is used to provide the top-up lighting, from a lower ambient level up to the selected task illuminance. This allows a low general level of light to be provided across a large space with only the actual task areas being used lit to the higher task illuminance. This can be a very energy-efficient way of lighting a space.

Generally a 2:1 ratio of task-lighting level to general-lighting level gives a reasonable balance between energy saving and visual comfort. 300 lux general lighting plus 200 lux task lighting to give a resultant 500 lux on the task is a good balance. With a smaller proportion of task lighting, say 400 lux plus 100 lux, results in a much smaller energy saving for a similar investment in the task lights. A bigger difference, say 200 lux plus 300 lux, may mean that some users feel that they are working in a bright pool of light in a gloomy space.

Task lights should be positioned so as to throw light from the side of the task area. Ideally, it should be possible to have the light coming from either the left- or right-hand side of the desk, to suit the user. The spread of light should cover, as evenly as possible, the area of desk used for reading written text. Uniformity over the task area of 0.8 should be achieved. It is important that the luminaire be provided with a local switch or ideally a dimmer control.

Positioning local lights in front of the user can result in low contrast between the text and background of any paper on the desk in front of the user, and can even provide a source of reflected glare if the paper is glossy.

The luminaire should have a limited range of adjustment, to allow the user some control over its position, but not so much that it can become a source of glare to other office users. The luminaire should not be positioned so low that deep shadows are formed by light being cast across the desk at too shallow an angle. It is recommended that the height should not be less than 0.5 times the width of the area being lit, i.e. to light across 1 m of desk the height should be at least 0.5 m.

The light source in both the above types of desk light system should be of a good colour quality and have a low heat output. Suitable lamps would be linear fluorescent lamps or compact fluorescent lamps with high-frequency control gear. In certain installations, it may be possible to use very low-wattage discharge lamps, but the difficulty in dimming and slowness to re-strike after switching off reduces the user's control of the lighting.

If the task light is accessible to the user, it is vital to ensure that it is mechanically and electrically safe and is both cool to the touch and cool enough to work beside. This is especially important in areas, such as libraries, where the users may not be familiar with the operation of the lights.

Figure 18 Adjustable low-energy task lights combined with ceiling luminaires providing general lighting



4.4 Energy usage

As with all building types, energy usage is a combination of the energy consumption of the individual luminaires and the time that they are in use. The time for which any particular group of luminaires is on depends on whether there is work being carried out in that area or if there is sufficient daylight to allow the lights to be turned off. Of course, this assumes that people or automatic systems will turn off those lights on such occasions. This issue are covered in section 4.5 'Controls'.

The first step in minimising energy use is to avoid over specifying. A competent designer should aim to provide as closely as possible the maintained illuminances for each task as specified in the schedule of task illuminances contained in the *Code for Lighting*. If the actual maintained illuminance is below the requirement, then the task may well be performed below normal expectations, leading to low output or increased mistakes. If the level is too high, then unnecessary amounts of energy will be consumed by the installation throughout its life. There are methods whereby over-specified levels can be reduced by the use of controls, and this is covered in the 'Controls' section (section 4.5).

In areas where there are tasks being carried out with varying task lighting levels or where there are users with varying lighting needs (age or performance related), it is normally most efficient to provide general background lighting that provides the minimum required and have task lighting or localised lighting available to boost the lighting levels for those specific users who need it. Task lighting under the control of a user also improves that user's sense of being in control of their environment.

The next step in avoiding unnecessary energy use is to specify the most efficient luminaires that will provide the illumination levels and lighting quality required for any given area. This means looking for luminaires with high utilisation factors and low energy consumption. The use of high-frequency ballasts or transformers rather than wire-wound versions helps in reducing energy consumption.⁽⁷⁾ See section 2.4.2 'Energy efficient equipment' in the *Code for Lighting*.⁽⁴⁾

The lighting contained in any new or refurbished office building has to produce more than 40 Luminaire Lumens per Circuit Watt on average to meet the requirements of the Building Regulations, *Approved Document L2, 2000*.⁽³⁾ 'Luminaire Lumens' are defined as the product of the number of lamps in the luminaire, their initial lamp lumens and the light output ratio (LOR) of the luminaire, all divided by the circuit wattage of the lamps and control gear in the luminaire. Therefore, to obtain a high figure one needs some combination of efficient lamps, with high initial lumen output, efficient luminaire optics, giving a high LOR, and low energy consumption by the control gear. Note that the Building Regulations requirements are likely to become more stringent during the next revision in 2005.

4.5 Controls

Good practice dictates that all lighting should be simply and easily controlled without the user having to traverse long distances, hunt out switches in cupboards or be faced with large numbers of un-labelled switches on a central switch-plate. The Building Regulations, *Approved Document L2, 2000*⁽³⁾ states the following about lighting controls:

1.55 Where it is practical, the aim of lighting controls should be to encourage the maximum use of daylight and to avoid unnecessary lighting during the times when spaces are unoccupied. However, the operation of automatically switched lighting systems should not endanger the passage of building occupants. Guidance on the appropriate use of lighting controls is given in BRE IP 2/99.⁽⁸⁾

Controls in offices and storage buildings

1.56 A way of meeting the requirement would be the provision of local switches in easily accessible positions within each working area or at bound-

aries between working areas and general circulation routes. For the purposes of *Approved Document L2*, reference to switch includes dimmer switches and switching includes dimming. As a general rule, dimming should be effected by reducing rather than diverting the energy supply.

1.57 The distance on plan from any local switch to the luminaire it controls should generally be not more than eight metres, or three times the height of the light fitting above the floor if this is greater. Local switching can be supplemented by other controls such as time switching and photo-electric switches where appropriate. Local switches could include:

- a) switches that are operated by the deliberate action of the occupants either manually or by remote control. Manual switches include rocker switches, push buttons and pull cords. Remote control switches include infra red transmitter, sonic, ultrasonic and telephone handset controls.
- b) automatic switching systems which switch the lighting off when they sense the absence of occupants.

Automatic controls in offices fall into one of three types: daylight linked, occupancy linked or time of day. Each type of control can be used most effectively in differing circumstances.

For spaces where there is a significant amount of daylight available for significant periods of the year, daylight-linked systems can be used to switch off or dim individual lights or rows of lights by the windows.⁽⁹⁾ Care is needed in setting up such systems to ensure that the switching or dimming is not too obvious or frequent and does not leave the users with too little light at any time. Otherwise user resistance may lead to the system being turned off (see Figure 19). See also section 5.1 'Interaction between daylight and electric light'.

Figure 19 Row of luminaires nearest the window switched off as there is sufficient daylight



In spaces that are used intermittently, such as some stores or toilets, an occupancy system can be used. This turns off most of the lighting after a set delay from the last detected movement. Such detectors can sense movement or sound and need to be carefully selected and sited to ensure good coverage of the space. For instance, a single movement detector in the main body of a toilet may fail to detect someone sitting in one of the cubicles. A sound-sensing system may not be able to detect a single person sitting studying data on a screen or in a book.

It is not advisable automatically to turn off all the lighting in an area with no daylight or borrowed light from an adjoining area, in case someone is still present but had not been moving sufficiently to keep the system activated. In larger spaces, the lighting can be arranged to go off in two stages, so that the first stage acts as a warning to anyone present, or one or two lights can be left on as safety lighting.

Simple time-control systems are normally used for decorative lighting elements such as external floodlighting or feature lighting in an entrance hall. For internal areas, these can be simple time clocks that turn off the lighting say one hour after close of normal business. For external lighting, a solar-dial time clock is normally used as this switches the lighting on at a fixed period before or after dusk each evening and off at some set time when it is judged that there are few passers by to view the lighting. The solar dial adjusts automatically as the days grow longer or shorter through the year.

Time control can also be programmed into internal control systems to turn off some of the lighting at lunchtime, leaving users to turn their lights back on again if required when they return from lunch. The system can also turn some or most of the lighting off in one or more stages after normal working hours. See the *Code for Lighting*⁽⁴⁾ section on 'Controls' (section 4.5) for more details. In open-plan office areas, lighting of circulation routes must be kept on when people are working anywhere on the floor, and some lighting should remain on across the office to provide a good visual environment when a worker looks up from his/her task.

4.6 Designing with direct lighting

Direct lighting uses luminaires that are designed to emit the majority of their light output directly down onto the working plane. Any upward light emitted plays an insignificant part in lighting the task. Direct luminaires can be surface mounted, recessed into the ceiling or suspended. They are generally viewed as separate lit objects in the space and for this reason can appear bright if viewed against a dark ceiling, or as a distinct and possibly distracting object when reflected in a display screen.

The downward flow of light from direct luminaires means that the lower surfaces of the room are lit in preference to the upper walls and ceiling. The extent of this varies from one luminaire type to another. Those that emit some light sideways or upwards provide some direct light to the walls and ceiling. Downlights with a restricted distribution to the side, perhaps intended to reduce direct and reflected glare for display screen users, provide little light directly onto the walls. This can lead to rather dark walls unless the floor and working plane surfaces are light so as to reflect light onto the walls and ceiling. As described below, it is possible deliberately to wash light over the walls so as to offset their dark appearance. The walls and ceilings themselves should be light coloured so as to appear brighter. See section 4.7.1 on room décor for more on the effects of surface reflectance on the visual environment (see Figure 20).

Figure 20 Dark ceiling due to low working plane and carpet reflectance



Figure 21 Industrial style luminaires used in high office space



Direct lights can be completely recessed into the ceiling, partially recessed, surface mounted or suspended. The completely recessed type gives just down-light with no light onto the surrounding ceiling. These are therefore likely to appear bright when compared with the surrounding ceiling and can, in extreme cases, cause problems with glare and reflections in display screens. As they are also likely to have the least sideways flow of light across the space, they may make the room appear gloomy, since the vertical room surfaces will not be well lit. It is normally better to choose luminaires that have some diffusing or reflecting element below the ceiling level that can direct a small proportion of the light across the ceiling.

Direct luminaires in offices do not always need to be fluorescent. In tall spaces luminaires using discharge lamps can often be used. This can mean greater efficiency although the same minimum colour rendering index of $Ra80$ should be met and the same glare limitation needs to be achieved. With all high-level lighting, a means of safe access for maintenance and re-lamping must be considered as part of the design process (see Figure 21).⁽¹⁰⁾

Surface-mounted and suspended luminaires can easily be selected to throw a varying proportion of light onto the ceiling around or above them. This improves the lit appearance of the space and reduces the apparent contrast between the luminaire and its background. One possible problem with these types of luminaire is that they can interfere with airflow from supply grilles and cause localised dumping of cold air. It is always necessary to liaise with the mechanical engineers involved in the design of any air-supply systems on the interrelationship of grilles and luminaires.

Direct luminaires can be arranged in a uniform grid to give a uniform level of illumination across the whole space, or can be arranged in co-ordination with desk locations to give a localised boost to the lighting level on the desks, with lower levels between. The former is the simplest when there is no knowledge of likely desk positions or where the locations will vary. Even with uniform grids of luminaires across a space, with additional investment in individual dimming luminaires it is possible to have higher levels over desk locations and lower levels between. Section 3.3.1 on selection of illuminance gives more information on selecting lighting levels.

4.6.1 Luminaire layout with direct lighting

The luminaire layout adopted will depend on the type of installation, the illumination level selected, and the constraints of the space. A uniform layout across the space can be designed to give a uniform lighting level across the space. This allows desks to be placed in almost any position and still receive the designed maintained illuminance. Unfortunately, it can be rather uninteresting visually unless supplementary feature lighting of artwork, notice boards or vertical surfaces is provided.

Non-uniform layouts of luminaires can provide more visual interest in the space and concentrate lighting just where it is most needed. Desks only occupy 25–30% of a typical office space. Therefore, where the working practices of the office mean that there are fairly fixed layouts of desks, the luminaires can be positioned local to the desks giving more light where it is needed and less over non-task areas, leading to energy saving. See section 4.2 ‘Designing with localised lighting’ for more details.

4.6.1.1 Partitions

Part-height partitions around desks may block some light to the desks in varying degrees depending on their relationship with the luminaires above. The higher the partitions or the further apart the luminaires, the worse this problem becomes. Over-desk storage furniture makes the problem much worse. By using more, lower-output luminaires spaced closer together, the shadowing can be reduced. Conversely, designing a scheme with the fewest luminaires spaced at their maximum will usually lead to shadowing whenever partitions are used. Where it is known that high partitions and/or over-desk storage are to be used, then task lighting, either freestanding or built into the furniture, must be included in the design.

4.6.1.2 Cellularisation

Where there are open-plan areas that may be divided into cellular offices, the selection and layout of luminaires need careful thought. The layout of luminaires will need to relate to possible partition positions such that, when an office is created, it has the correct number of luminaires within it to provide the required illuminance (see Figure 22). The lighting design will need to take into account these possible partition arrangements and allow for suitable task-lighting levels and uniformities in a range of cellular office modules from a fixed lighting grid. See section 3.3.3 ‘The effect of re-locatable walls on lighting levels’ for more information.

Figure 22 Wide spacing of luminaires leads to deeper shadows from partitions and furniture

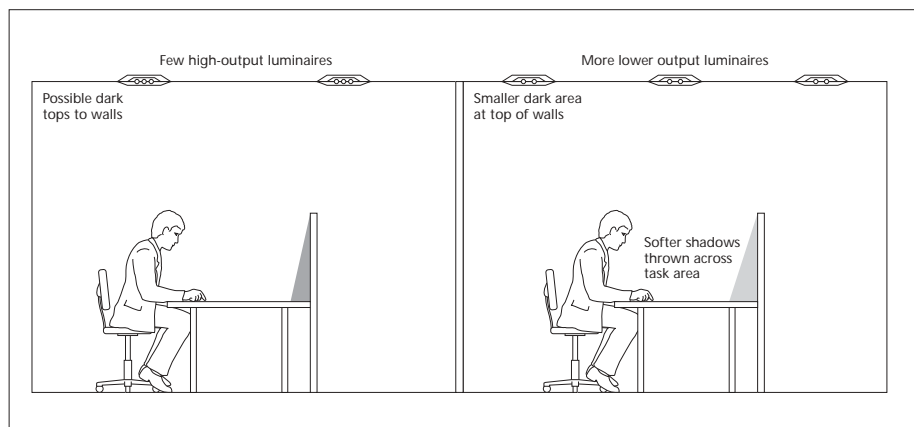

4.6.1.3 Perimeters

It is important to consider the perimeter spacing of luminaires and their proximity to walls and columns (see Figure 23). This is because some luminaires can produce bright scallops on surfaces close by. This is especially likely at the ends of a linear luminaire. A gentle wash of light onto walls is to be encouraged, but sharp transitions from light to dark can be distracting and can show-up as distinct images in display screens. In general, the peak luminance of the scallop should not exceed 1500 cd/m². If this cannot readily be calculated, it may be

Figure 23 Wall washers can be installed to evenly light dark end walls and to reduce the impact of scallops from the ends of fluorescent rows

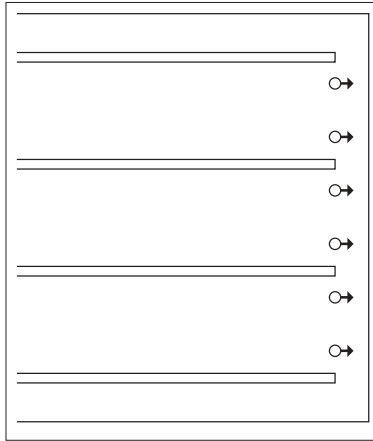

Figure 24 Circular direct luminaires following the curve of the wall



4.6.1.4 Irregular room shapes

preferable to keep luminaires set back from walls. This may, however, lead to a reduced task illuminance on desks placed near to the walls and to dark walls. Perhaps better would be to use asymmetric luminaires to serve as wall washers since an even wash of light with a slow rate of change is preferable to uncontrolled scalloping. Dimming control can be provided to alter the brightness of the wall in relation to the body of the room

In non-rectangular shaped offices, the size and layout of the luminaires need not be uniform. Sometimes tailoring the number and size of the luminaires to match unusual room geometry can add additional visual interest to a space. For odd corners or recesses, circular fluorescent lights can be used or, if the area is not a main task area, perhaps a recessed spotlight can be used to highlight the recess. Figure 25 gives examples where it may not be necessary to light small parts of an office and where changes to a standard type of luminaire are justified (see also Figure 24).

4.6.2 Direct lighting and display screens

With nearly all-modern offices the lighting designer will have to take into account the use of display screens on most desks. The brief is unlikely to indicate the type of display screens or give any guidance on their locations. In such cases, the designer must consider the type of luminaires to be used and design the layout of the luminaires to suit the likely use of display screens in each area.

With luminaires on or near the ceiling directing their light downwards, there is an obvious danger of them being visible in display screens below. Whether they can be seen or not will depend on the tilt of the screens and their relationship to the screen user and the luminaires. If luminaires are likely to be seen, then it needs to be established whether they are bright enough to be a distraction to the user. This partially depends on the clarity, or sharpness, of the reflected image on the screen and partly on its luminance compared with the luminance of the information on the screen. The sharper the image then the more likely the eye is to notice it; the higher the luminance of the reflected image the more difficult it is to read the screen information behind and around it.

Figure 25 Avoiding poorly lit room areas by varying luminaire length

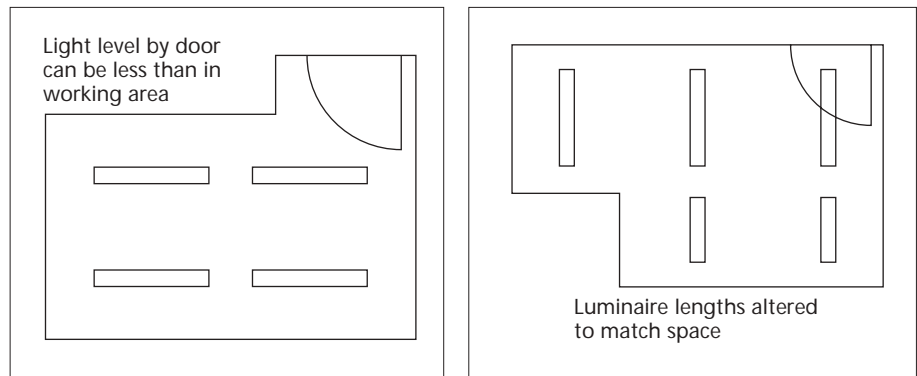

Figure 26 Severe reflections of a rooflight on a screen with no anti-reflection treatment



If the screen has a smooth, specular front glass, then the luminaire image will appear as a sharply defined object, which the user can see clearly. If the screen has some anti-reflective treatment then the reflected object is less well defined and is less likely to distract the user (see Figure 26).

If the software running on the screen uses light characters on a dark screen background, such as white text on a blue background, then the reflected image is going to be seen against this dark background. If, on the other hand, the information is presented with dark characters on a light background, then the reflections will be less visible against the lighter background.

Thus if a luminance value for a luminaire is to be set such that it is unlikely to distract the majority of users running typical applications on standard screens, it needs to be established whether the screens in the area have surface treatment and whether the information displayed on the screen is dark characters on a light background (positive polarity), or light characters on a dark background (negative polarity).

In some cases, it cannot be established with any certainty that the screens in an area will be modern screens with an anti-reflective surface treatment, or that all software being run in an area is set to display dark characters on a light background. In these cases, if the luminaires' luminance limit is set for the worst case of dark background display on clear-fronted display screens, the flow of light across the space will be low and the room is likely to look less well lit than if a higher luminance limit had been used. It is generally better for the designer to establish with a client or user group that the screens in an area are likely to have screen treatment, or that all software is running with light backgrounds, as a higher luminance limit can then be used.

4.6.2.1 Luminance limits

The luminance limits recommended for luminaires with various types of screens are set out in Table 2. Where only screens using positive polarity software will be affected by the lighting, then the specifier can increase the luminaire's luminance limit to the figures indicated below Table 2.

Table 2 Luminance limits for various screen types

Screen type	Maximum luminance (cd/m ²) where some negative polarity software used
Type I and II	
Good or moderate screen treatment	1000 cd/m ²
Type III	
No screen treatment	200 cd/m ²

Where positive polarity software only is being used on Type I and II screens the luminance limit can be increased to 1500 cd/m².

Where positive polarity software only is being used on Type III screens the luminance limit can be increased to 500 cd/m².

Note: This table is adapted from Table 4 in BSEN 12464-1.(11)

It is recommended that the luminance limits normally be applied at and above a 65° angle of elevation where the screens in the area are not tilted back beyond 15° from the vertical. In special circumstances, where screens may be unusually sensitive to reflections, a 55° luminance limit angle is recommended.

Direct lights within smaller cellular offices are unlikely to cause glare or screen reflections, since the geometry of small rooms means that luminaires are unlikely to be seen in the screens. In open-plan areas, however, luminance limitation is needed due to the long views to the luminaires. See Figures 27 and 28. In areas where there are re-locatable walls forming the cellular offices, care still needs to be taken

Figure 27 For typical screen arrangements reflections of luminaires and windows far back in the office are possible

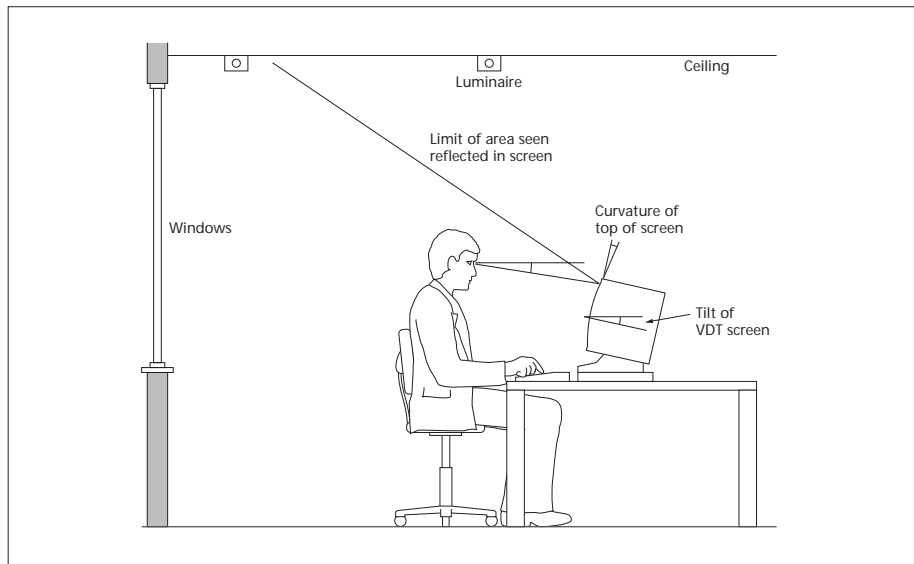

Figure 28 With smaller office spaces there is far less chance of seeing luminaires reflected in the screen

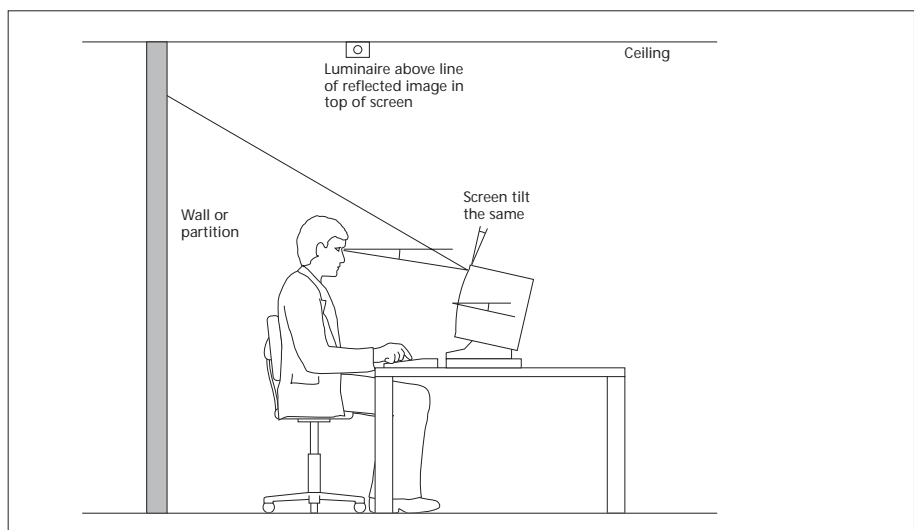



Figure 29 Reflections on keyboard function panel

4.7 Designing with indirect lighting

in selecting the luminance limits for the luminaires in them, as the offices may later be opened up to become part of the open plan area and their luminaires may then be visible across the space. See also section 5.2 'Daylight and display screens'.

Note that, in some dealer's rooms, there may be horizontally mounted information or keying screens and large numbers of screens per station and many workstations in different orientations. Such specialised installations need very careful consideration of the geometry and relative positions of the luminaires and screens. Proving the design by use of a full-scale mock-up is invaluable in such cases (see Figure 29).

Indirect lighting uses luminaires where all, or almost all, of the light produced by the luminaire is reflected off some surface, usually the ceiling, before reaching the working plane. Therefore it is important to ensure that this surface has a high reflectance. The lighting produced by an indirect lighting installation is typically diffuse, without strong modelling effects or strong shadows. To avoid the space appearing bland, it is important to use the interior décor to create some variety and interest in the interior.

Indirect lighting can be used to provide the general lighting to an entire area or be used to provide localised lighting in the centre of groups of workstations. The indirect luminaires can take several different forms, depending on the means of mounting the indirect light. The most widely used mounting positions are free-standing, floor-mounted units, units mounted on furniture, wall- or column-mounted units, and units suspended from the ceiling. All these forms directly light the ceiling and upper parts of the walls and so indirectly light the working plane. To ensure maximum efficiency, the ceiling surfaces must be of a high-reflectance, matt finish.

Indirect lighting can be used successfully to light rooms containing display screens, as the surfaces being lit by the indirect light act as large-area, low-luminance luminaires. As long as the luminance of these surfaces is not excessive, any reflections seen on the screen are of a gradually changing low luminance.

As well as the standard types of indirect lighting, there are other forms that are less common but can generally meet the requirements of using the ceiling as a large-area, low-luminance luminaire. They are where asymmetric luminaires are mounted on high-level shelves or on a cove along the sides of ceiling bays or coffers. These then throw light out as evenly as possible across the ceiling. Another type of lighting that produces a similar effect to soft, even indirect lighting is the creation of a luminous ceiling.

4.7.1 Surface reflectance and décor

In order to ensure a reasonably efficient installation, the ceiling and upper walls should have a high reflectance. A minimum reflectance of 0.7 is recommended. To allow for dirt build-up and degrading of the surface, an initial surface reflectance of 0.8 should be aimed for. Ceilings of lower reflectance can be used, but at the cost of additional installed load. If these surfaces are highly coloured, the light reflected back down onto the working plane will be highly coloured. White, or at least very pale colours, should be used for the major areas of the reflecting surfaces in indirect lighting installations (see Figure 30). The surfaces should be matt, as a specular finish will produce high-luminance images of the lamp when viewed from particular directions. Rough surfaces have a lower effective reflectance than a smooth surface of the same colour due to all the crevices in the surface. Also, be careful with old buildings as indirect light may highlight any defects in wall or ceiling surfaces.



Figure 30 Alternating wall and column mounted indirect lights give a fairly even ceiling luminance

It is important in uplit spaces to use the interior décor to create some variety and interest in the space. This could involve small areas of strong colour, picking out salient architectural features, for example, but care should be taken to avoid abrupt changes in reflectance. It is also possible to add variety to the space by introducing some feature lighting via gentle spot lighting of features such as notice boards or art works. This should not be so bright that the objects become possible sources of reflection on any display screens in the area.

In addition, the colour scheme should be matched to the colour properties of the light source used. For example, an interior filled with blues and greens would look very subdued under high-pressure sodium discharge lamps but one filled with orange and yellow would be very vibrant. In this area, there is no substitute for seeing the proposed colours under the light source of interest.

It is sometimes assumed that a completely flat surface is necessary for a successful indirect lighting installation. This is incorrect. In fact a degree of shape or structure in the main reflecting surface can go a long way to provide some variety in the appearance of the space. However, the structure should have as smooth a profile as possible to minimise sharp changes in luminance. Similarly, inclined ceilings, although requiring more thought in the calculation of light levels and the distribution of the lights, can provide very interesting spaces. For ceilings with exposed structures, care should be taken to avoid sharp contrasts between directly lit and unlit areas as these may start to appear as distinct objects when reflected in display screens.

4.7.2 Design criteria for indirect lighting

For indirect lighting to be successful, it is essential that the luminances of the reflecting surfaces be limited. It is recommended that:

- (a) The average luminance on the major surfaces used for reflecting light, such as the ceiling, should be less than 500 cd/m².
- (b) The maximum luminance of any point on the major surfaces reflecting light should not exceed 1500 cd/m².
- (c) The value of luminance should change gradually across the surfaces, i.e. there are no sudden changes in luminance across or between surfaces.

The calculation for maximum ceiling luminance over a single indirect light will give a guide to the expected maximum in the final installation. However, it should not be forgotten that the adjacent indirect lights in a real installation would add perhaps an additional 25% to the calculated maximum value from a single indirect light. Where mobile, free-standing units are being recommended, the client/user should be reminded that standard symmetric units should not be moved close to walls or columns because this will reduce the efficiency of the indirect light and produce a high-luminance patch on the wall or column. Such a patch is likely to be a source of complaint to display screen users both in terms of direct glare and by being reflected in their screen.

4.7.3 Luminaire selection for indirect lighting

The desirable photometric properties of free-standing, furniture-mounted and suspended indirect lights are that they should have as high an upward-light-output ratio as possible and should spread the light emitted over as wide an area as possible without allowing a view of the lamp or luminaire interior. Unless the luminaire has a widespread luminous-intensity distribution, there is a risk of creating a high-luminance spot immediately above the indirect light and hence of exceeding the maximum-luminance criterion. For wall-mounted indirect luminaires, the luminous-intensity distribution should be asymmetric such that there are no high-luminance spots above 1500 cd/m² immediately above the unit on the wall or ceiling.

A related aspect of using indirect luminaires is that there should not be a very sharp cut-off in the luminous-intensity distribution at any angle because this may produce a step-like change in luminance on the ceiling or wall of the interior. One other feature of the indirect luminaires that needs care is the reflectance of the underside of the luminaire when suspended indirect lights are used. Such indirect luminaires are seen in silhouette against the ceiling, which means that, unless they have fairly light undersides, a sharp change in luminance will be evident.

Because most indirect luminaires rely on upward-facing reflectors, it is essential that ease of maintenance be considered carefully when selecting the indirect luminaire and designing the installation. Easy access is essential if good

light output is to be maintained. Floor-mounted indirect luminaires may offer the possibility of replacing units for ease of maintenance. Maintenance, and safety, may be enhanced by ensuring that the indirect luminaire is fitted with a removable glass cover but, to ensure full lamp life and aid the self-cleaning of the lamp and reflector, the cover should not be sealed. This is to allow a convective air stream to pass through the indirect luminaire when the lamp is lit. Free-standing indirect luminaires should incorporate tilt switches to ensure that the unit switches off if it is knocked over.

4.7.3.1 Mounting height and locations

Indirect luminaires rely on height to shield a direct view of the lamp and interior from the occupants. This is the reason why the vast majority of floor-mounted indirect luminaires are at least 1.8 m high. Similarly, wall-mounted and furniture-mounted indirect luminaires should have their top surface located at about 1.8 m above the floor. This minimum height imposes a limit on the ceiling height that is acceptable for indirect lighting. As a rule of thumb, most commercial floor-mounted indirect luminaires should be used with ceiling heights of between 2.5 and 3.5 m above floor level. Indirect luminaires can only be used successfully with ceiling heights below 2.5 m if particular attention is paid to the luminous-intensity distribution and means are taken to avoid the creation of a high-luminance spot immediately above the indirect luminaire. Ceiling heights greater than 3.5 m can be used, but at extra cost in terms of installed power. If indirect lighting is required in a space with a ceiling height above 3.5 m, wall-mounted or suspended indirect luminaires should be considered as long as safe maintenance access can be ensured.

Care should be taken when positioning large indirect luminaires over, or close to, a desk or work surface. The effect of direct radiant heat from the body of the indirect luminaire to the users nearby should be considered when selecting indirect luminaires. Large indirect luminaires can themselves act as an obstruction to the lit ceiling above. Although any shadow thrown by the indirect luminaire will be very soft – due to the large lit area of ceiling – it may locally reduce the total illumination.

4.7.3.2 Suspended indirect luminaires

Here the major requirement is to ensure that the units are suspended far enough below the ceiling to provide a wide, soft spread of light onto the ceiling. There is often a temptation in very large spaces to install a few high-wattage units to save money. This may well result in separate high-luminance spots appearing on the ceiling.

In all cases, the luminaires need to be suspended well above normal head height to prevent users of the space feeling that they may strike their heads on the units. A minimum height of 2.3 m is recommended. A light coloured body is recommended so that the luminaire does not appear as a dark object against a light ceiling.

4.7.3.3 Cove lighting

Cove lighting again aims to throw light evenly onto the ceiling from a ledge or recess high up on the wall. Unless luminaires with purpose-designed reflectors are used, there is a danger of the back wall of the cove and the ceiling adjacent to it becoming very bright (see Figure 31). Great care has to be taken to ensure

Figure 31 Cross-section of a typical cove lighting system

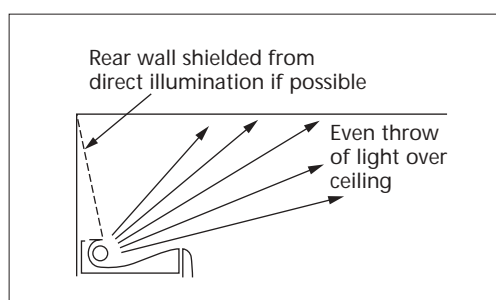

that the luminances of the surfaces in the cove do not exceed 1500 cd/m^2 . Depending on the cove's distance below the ceiling, it may be difficult to light the ceiling evenly beyond the first two to three metres from the cove, due to light fall-off on the ceiling. If the ceiling is curved up gently from the cove, the ceiling illuminance is likely to be more even. The average illuminance on the working plane can be calculated using the lumen method once the utilisation factor has been calculated by the methods given in the calculation section of the *Code for Lighting*⁽⁴⁾ (see Figure 32).

4.7.3.4 Luminous ceilings



Figure 32 Cove lighting

While a luminous ceiling is not an indirect system of lighting, it creates a similar effect of soft, even ceiling luminance, although often too even and perhaps bland. Luminous ceilings were popular 30 years ago but appear only rarely today. They generally pose major problems of access for re-lamping and cleaning. The cavity above the luminous ceiling should be painted white and has to be high enough to conceal the light sources from view through the diffusing material below.

Luminous ceilings can vary widely in efficiency, depending on the form and transmission of the ceiling material and the light source used. They can have lights flooding up into the cavity or have closely spaced arrays of fluorescent lamps across the top of the cavity. The average illuminance on the working plane can be estimated using the lumen method or calculated using many computer programs. The average luminance of the ceiling needs to be below 500 cd/m^2 .

Frosted or opal lay-lights below roof lights can have some of the characteristics of a luminous ceiling, although their luminance is variable and depends on prevailing daylight conditions. They are often smaller and hence suffer from contrast problems with the relatively darker ceiling alongside.

4.8 Designing with direct/indirect lighting

This section looks at the designs where the intention is to provide the illumination for the working area by using luminaires designed to provide both indirect and direct light.

The combination of direct lighting and indirect lighting can be very effective, as the two types of lighting are in many ways complementary. By using a combination of indirect and direct lighting, a lit environment can be produced

Figure 33 Luminaires hung over desks to provide localised light and avoid obstruction of space and avoid obstruction over circulation space



which has well lit walls and ceilings while also having some directional element to provide modelling. The horizontal illumination is good without either creating a gloomy interior or having over-bright ceilings and walls. The exact proportion of indirect light to direct light is not critical in most circumstances, although the room's visual characteristics will be markedly different as the proportions change. At one extreme are indirect lights that provide direct light through translucent elements on the bottom of the luminaire or from reflectors to their side. At the other extreme are suspended direct lights that allow a reasonable proportion of soft indirect light through slots or diffusers in the top of the luminaire (see Figure 33).

The switching and control of the luminaires needs to be carefully considered. With many luminaires, the option exists to switch or dim the direct and indirect elements of the luminaire independently. This can be useful as it allows the users another degree of freedom in selecting their preferred visual environment. It can, however, lead to some problems. The indirect light from one unit may affect a number of users and any reduction of the luminance of the ceiling may make the direct element of the luminaires more prominent to some users.

To ensure a reasonably efficient installation, the ceiling and upper walls should have a high reflectance. A minimum reflectance of 0.7 for the ceiling is recommended. To allow for dirt build-up and degrading of the surface, an initial surface reflectance of 0.8 should be aimed for. If these surfaces are highly coloured, the light on the working plane will have some tint of this colour. White, or at least very pale colours, should be used for the major areas of the reflecting surfaces. The surfaces should be matt as a specular finish may produce high-luminance images of the lamp when viewed from particular directions.

When using direct/indirect luminaires, it is important to ensure that each component meets the luminance criteria laid down in the criteria sections for direct lighting and for indirect lighting. The direct lighting elements still need to have luminance limits suitable for the intended display screens and their use, and the indirect component still needs to provide an even wash of light over the ceiling. However, if the ceiling is uniformly lit then it is acceptable to allow the luminance of the direct component to increase to match the average luminance of the ceiling.

4.8.1 Luminaire selection for direct/indirect lighting

The luminaires can provide the indirect and direct light either from separate lamps and reflectors, or from the same lamp or array of lamps (see Figure 34).

This latter type of luminaire can be highly efficient, especially where one set of lamps can be utilised to provide both indirect and direct light. The lamp type used can vary widely. The more typical are high-efficiency fluorescent lamps in linear luminaires, but discharge lamps and compact fluorescent lamps can be used.

One type of combined luminaire comes complete with its own indirect light 'canopy'. This may take the form of large white wings that catch and redirect the indirect light. These are usually suspended so that light spreads up onto the ceiling above. However, it is possible for the wings to be integrated into the ceiling in place of one or more ceiling tiles (see Figure 35). In these cases, it is important that some light from a dropped 'basket' provides some light onto the ceiling surrounding the luminaire to reduce the contrast between the lit wings and

Figure 34 Luminaire with direct and indirect components

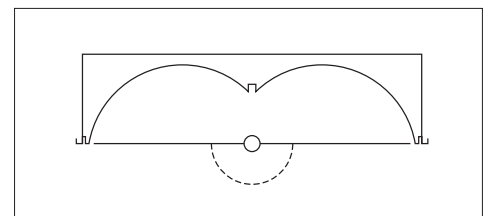
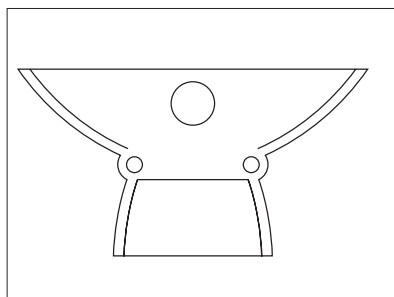

Figure 35 Recessed luminaire with indirect light into a canopy as well as direct light

Figure 36 Reflectors suspended below direct luminaire reflect light back up onto ceiling



the unlit ceiling beyond. Luminaires can also be positioned within larger coffers that are part of either the ceiling or the structural soffit. This coffer forms a large upper reflector that utilises the indirect light from the luminaire.

Suspended direct/indirect luminaires should be suspended far enough below the ceiling to provide a wide soft spread of light onto the ceiling. In all cases the luminaires need to be suspended well above normal head height to prevent users of the space feeling that they may strike their heads on the units. A minimum height of 2.3 m is recommended (see Figure 36).

Where a luminaire has a separate lamp for the direct light and another one for the indirect light, it can usually be arranged to have a single ballast controlling both lamps or a separate ballast for each lamp. With separate ballasts, the indirect and direct lighting components can be controlled separately if required. This can provide permanent background lighting across the office space from the indirect component with user control of the direct component over their work stations. It can also be used to provide a reduced level of lighting for cleaning or when operating from a standby power supply.

For suspended indirect/direct lights, it is important to realise that the luminaire body will be viewed against a relatively bright ceiling. This means that the body should be light to avoid the contrast of a dark body against a light background, as this effect may be noticeable on a display screen. Another way to avoid this problem is for the sides to be made of a translucent or light mesh material. It is important that the luminance of the sides does not exceed the design luminance of the ceiling against which they are to be viewed.

4.9 Designing with a combination of direct light and indirect light

The combination of fixed direct luminaires and separate indirect luminaires can be effective, as the two types of lighting are in many ways complementary. By combining indirect and direct lighting, it is possible to create a lit environment which has well lit walls and ceilings while having some directional element to provide modelling. The horizontal illumination is good without either creating a gloomy interior or having over-bright ceilings and walls. The exact proportion of indirect light to direct light is not crucial in most circumstances, although the room's visual characteristics will be markedly different as the proportions change (see Figures 9 and 37).

Such lighting usually takes the form of direct high-efficiency luminaires within the ceiling combined with free-standing or wall-mounted indirect luminaires to provide well-lit ceiling and upper wall surfaces. Sometimes the indirect lights need to be added to a direct lighting scheme to relieve a potentially dark and gloomy ceiling.

Sometimes, indirect lights are added to an area to soften or alter the effect of an existing direct lighting installation. When this is done it may be necessary to reduce the light output of the direct lights so as not to provide an excessive horizontal illuminance. This can sometimes be achieved by the removal of one lamp in a twin-lamp luminaire, although often the diffuser or louvre will need changing to improve the light control – this may well reduce the light output and affect the luminaire's light distribution. Where the two systems will be used together, care is needed to ensure that high-luminance images of the indirect luminaire do not appear on the flanges or louvre elements of the direct luminaires.

When using separate systems of floor-standing indirect lights and ceiling-mounted direct lights, it is important to ensure that each system meets the general criteria laid down in the criteria sections for direct lighting and for indirect

Figure 37 Left: Scheme with combination of direct/indirect and indirect luminaires
Below: Scheme with downlighting supplemented by suspended uplighters



lighting. The direct lights still need to have luminance limits suitable for any intended display screens and their use and the indirect lights still need to provide an even wash of light over the ceiling. However, if the ceiling is uniformly lit, it is acceptable to allow the luminance of the direct light to increase to match the average luminance of the ceiling. Indeed, if the direct-light luminance is much lower than that of the ceiling it is possible for the direct light to appear on a display screen as a dark object against the brighter ceiling.

5 Design options for daylighting

Daylight is an almost universal worker requirement. When given a choice, most people prefer a working environment with daylight to one without. They also like having a view through a window even if the view is not particularly pleasant. A view provides contact with the outside world and also allows the eyes to relax, particularly if the work involves looking at detail at close distances. The admission of daylight also tends to make the space feel brighter and more pleasant.

There is a range of documented evidence that confirms the intuition that excluding daylight can lead to increases in the number of complaints about the working environment, and may have potential adverse effects on productivity.⁽¹²⁾ BS 8206 Pt 2 1992⁽¹³⁾ states that:

‘an interior which looks gloomy, or does not have a view of the outside where this can reasonably be expected, will be considered unsatisfactory by the users.’

Regulation 8(2) of the Workplace Regulations⁽¹⁴⁾ states that

‘The lighting in [every workplace] shall, as far as is reasonably practicable, be by natural light.’

Sometimes, indirect lights are added to an area to soften or alter the effect of an existing direct lighting installation. When this is done it may be necessary to reduce the light output of the direct lights so as not to provide an excessive horizontal illuminance. This can sometimes be achieved by the removal of one lamp in a twin-lamp luminaire, although often the diffuser or louvre will need changing to improve the light control – this may well reduce the light output and affect the luminaire's light distribution. Where the two systems will be used together, care is needed to ensure that high-luminance images of the indirect luminaire do not appear on the flanges or louvre elements of the direct luminaires.

When using separate systems of floor-standing indirect lights and ceiling-mounted direct lights, it is important to ensure that each system meets the general criteria laid down in the criteria sections for direct lighting and for indirect

Figure 37 Left: Scheme with combination of direct/indirect and indirect luminaires
Below: Scheme with downlighting supplemented by suspended uplighters

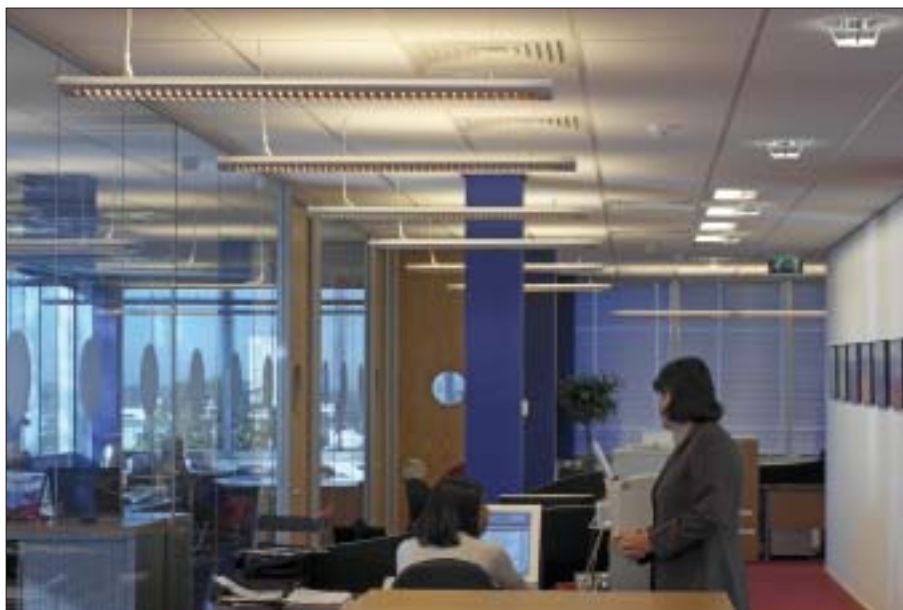

lighting. The direct lights still need to have luminance limits suitable for any intended display screens and their use and the indirect lights still need to provide an even wash of light over the ceiling. However, if the ceiling is uniformly lit, it is acceptable to allow the luminance of the direct light to increase to match the average luminance of the ceiling. Indeed, if the direct-light luminance is much lower than that of the ceiling it is possible for the direct light to appear on a display screen as a dark object against the brighter ceiling.

5 Design options for daylighting

Daylight is an almost universal worker requirement. When given a choice, most people prefer a working environment with daylight to one without. They also like having a view through a window even if the view is not particularly pleasant. A view provides contact with the outside world and also allows the eyes to relax, particularly if the work involves looking at detail at close distances. The admission of daylight also tends to make the space feel brighter and more pleasant.

There is a range of documented evidence that confirms the intuition that excluding daylight can lead to increases in the number of complaints about the working environment, and may have potential adverse effects on productivity.⁽¹²⁾ BS 8206 Pt 2 1992⁽¹³⁾ states that:

‘an interior which looks gloomy, or does not have a view of the outside where this can reasonably be expected, will be considered unsatisfactory by the users.’

Regulation 8(2) of the Workplace Regulations⁽¹⁴⁾ states that

‘The lighting in [every workplace] shall, as far as is reasonably practicable, be by natural light.’

There are, of course, working environments where daylight has to be excluded, such as photographic dark rooms, or where the amount or availability of daylight has to be controlled, such as presentation rooms or archives.

When the lighting designer is involved at an early stage of a building design, it may be possible for them to affect the overall window design. The aim should be to maximise available daylight across the working space while controlling unwanted sunlight or excessively bright sky areas. There is always going to be a degree of interaction between the daylight and the electric lighting. This can be exploited to reduce electricity usage by turning off or dimming down some or all of the lights in areas and at times when there is sufficient daylight.

It is said that daylighting office areas where display screen are used can be problematic. In the past, the policy was to divorce, as far as possible, display screens from daylight. This is clearly not an ideal policy in the modern office, given the popularity of daylight with the work force and the requirements of the health and safety regulations. Additionally, using electric lighting, without utilising daylight, can be wasteful of energy whilst leaving the designers with the problem of providing a suitable visual environment in the workplace by electric lighting alone. See section 5.2 'Daylight and display screens' for more guidance on this issue.

For a comprehensive guide to window and daylight design please consult CIBSE Lighting Guide 10 *Daylighting and window design*.⁽¹⁵⁾

5.1 Interaction between daylight and electric light

Most office spaces are lit to a varying degree by both daylight and electric lighting. The amount and distribution of daylight varies during the day and from day to day. The electric lighting tends to be more fixed and be controllable in steps or by area. It is always sensible to explore the feasibility of using the daylight as a source of useful illumination for the office, reducing the amount of electric lighting that needs to be employed (see Figures 38 and 39).

Section 4.5 'Controls' gives more guidance on the successful use of daylight in an office environment to save energy. Whatever type of lighting controls are installed, manual or automatic, the control zones within the overall space should be localised to groups of workstations. The individual zones should have switches close to the user to allow easy and convenient control of the lights in a local zone.

Figure 38 Daylight blends well with soft light from ceiling luminaires



Generally, the field of view of most office users includes areas of the interior with varying brightness and views through a window to brighter surfaces beyond and possibly to bright areas of sky. In such cases, the range of luminances in the field of view can be very large, possibly even greater than the simultaneous luminance adaptation range of the eye, so causing visual discomfort and potential visibility problems. By deliberately lighting the wall surfaces by the windows one can use the electric lighting to reduce the contrast. The use of some form of adjustable window screening is also recommended.

The appearance and luminance balance of the space need to be considered for all lighting conditions. The appearance during bright sunny days, when the

Figure 39 Rooflights with adjustable blinds on sloping windows and louvres on top windows



electric lighting may be off, is considerably different from the late winter afternoons or evenings where the daylight contribution may have faded completely.

5.2 Daylight and display screens



Figure 40 Soft daylight blends well with soft light from electric lights

In common with electric lighting the general design principle for daylighting display screen areas is to maximise the visibility of the screen display, while ensuring the best possible visual environment for the screen users and the other users of the space. There are the same problems with daylighting as there are with electric lighting, namely glare and veiling reflections. The difference is that with daylighting the source of light, the window, is generally much larger, it is more likely to be reflected in a screen and its luminance varies widely throughout the day and year. The very bright sun within the bright window is effectively a luminaire within a luminaire.

One of the simplest and most effective methods of achieving a satisfactory luminance range within the user's field of view is to arrange the correct viewing geometry for the workstation. This should avoid users looking directly out onto potentially bright patches of sky or having windows behind them reflecting on their screens. This generally requires that the display screens be placed as near perpendicular to the plane of the window as is practicable, so that the user's viewing axis runs nearly parallel to the windows.

Glare from windows can be caused both by diffuse skylight and, more seriously, by direct sunlight or sunlight on light window coverings (see Figure 40). Reducing the contrast between the sources and the internal wall surface can reduce glare from these sources. This can be achieved by reducing the brightness of the sky seen through the window, by covering the window, or by increasing the apparent brightness of the window surround. Note that susceptibility to disability glare increases markedly with age. See section 5.3 'Window and glazing design' below for more guidance (see also Figures 41 and 42).

However, these measures will not be sufficient to reduce glare from direct sunlight in rooms that receive it. In these circumstances, some form of nearly



Figure 41 Screen user in front of window with blinds up showing bright sky and sun



Figure 42 Screen user in front of window with blinds down maintaining view but avoiding glare

opaque shading device, such as roller blinds, will be required. Blackout blinds are not appropriate in most situations, and should be used only where there is a specific requirement. Whatever form of shading device is installed, the control of the device should be immediately adjacent to the window, and be easy to use. If this is not the case, and glare from sunlight is a problem, then users may tend to keep the blinds down and the lights on rather than constantly struggle with the blinds. This leads not only to a poor visual environment but also to excessive and unnecessary energy consumption for electric lighting. See sections 5.3.2 and 5.3.3 on internal or external shading devices for more advice.

It is also possible to add free standing part-height partitions between the screens and any problem windows. While this allows some adjustability in positioning and permits some daylight to pass over the partition, some obstruction to useful daylight flow across the space is inevitable. If the space has a large number of windows and screens, this technique will prove difficult to achieve satisfactorily and an extensive loss of a view for many users will result. Partitions can also cause shadowing of the electric lighting and reduce task illuminances and uniformity.

5.3 Window and glazing design

The shape of the windows has a dramatic effect on the availability and distribution of daylight across the space. Tall, narrow windows allow daylight deep into the space but also allow high bright sky to be visible to those working in the space. This can be dazzling and can cause distracting reflections on display screens. Making the windows shorter but wider minimises the area of high, bright sky visible through the window whilst still allowing a good view out and a reasonable distribution of daylight.

As well as glare, the direct sunlight provides high thermal gain, which can be a cause of considerable discomfort for users near to windows. Although beyond the scope of this Lighting Guide, consideration should be given to minimising adverse thermal effects when selecting shading devices.⁽¹⁶⁾ Where the windows provide means of ventilation, then the screening system must be selected to allow users safe and easy access to the window's opening devices. The movement of air through a window can cause annoying flapping or vibration of some screening systems.

Whatever the size of the window, there is a danger of the bright view and sky being seen against dark surrounding walls. The contrast with dark walls makes the sky and view appear even brighter than they are. To help reduce this sharp transition from bright windows to dark walls, the window reveals should be splayed and be of a light colour. They will then act as an intermediate step in brightness and reduce the apparent contrast between the bright window and the surrounding wall surfaces.

Where it is not possible to reduce the magnitude of the luminance step in this way, it may be helpful to place a row of luminaires close to the window wall. This will increase the illuminance of the window surrounds and may also

improve the night-time appearance of the space. Care needs to be taken to avoid over-lighting the wall or giving bright scallops on the wall that may appear as images on display screens.

There are a number of ways of reducing sky brightness by using various special glazing techniques. These techniques, if not handled well, may reduce the availability of daylight in the interior of the space which can adversely effect the energy efficiency of an installation as well as depriving users of the benefits of daylight. Even with these treatments, there is normally a need for window screening measures to reduce high sky brightness and sunlight penetration. For a fuller discussion of window design, refer to CIBSE Lighting Guide 10 *Daylighting and window design*.⁽¹⁵⁾

5.3.1 Glazing options

5.3.1.1 Prismatic glass

This is a panel of prismatic refractors installed in the upper part of the window. Its effect is to bend the light from the upper sky up onto the ceiling. This can be effective in throwing daylight deep into the space and reducing the brightness of the upper window. When purpose designed for the room, the refractor panel appears relatively dark and the ceiling wash is uniform. If the prismatic refractors are poorly designed, the ceiling close to the window may be too bright. If low-quality refractor systems are used, there is a danger of light and dark banding occurring within the prisms; this can be distracting when reflected in display screens.

5.3.1.2 Tinted or reflective glass

Whether these treatments are incorporated in the glass or are a stick-on surface film, the result is the same – they both provide a uniform reduction in transmission. This means that, although the high sky luminance is reduced by a given percentage, it also reduces the brightness of the general view.

This can result in a dull view, especially on an overcast day and with the bright parts of the sky and the sun only partially diminished. If tinting is required for solar control, it is recommended that the tint of the glass be close to neutral, to avoid adaptive colour shift between the external view and the room interior.

5.3.1.3 Fritted glass

This type of glass has small coloured dots, or frits, fixed to its surface. These are used to reduce the transmission of light and, where the outer surface of the dots is white, to reflect the sun's rays. Where the inner face of the dots is also white, the window restricts the view out. Where the inner face of the dots is black, a view out is possible.

If uniformly applied to a window, fritting could lead to a dull view out. This technique could be extended to allow a gradation of dots from the top to the mid part of the window. This would allow maximum attenuation of the bright upper part of the window, progressively reducing until the bottom where a clear view out was provided.

5.3.1.4 Screening

There are also ways of reducing sky brightness by internal or external shading devices. These techniques have to be handled well because they reduce the availability of daylight in the interior of the space, which can adversely affect the energy efficiency of an installation, as well as depriving users of the benefits of daylight.

5.3.2 Internal window shading options

Many forms of internal window screening are available, from straightforward curtains to vertical louvre drapes. Whatever method is chosen, simple local control and adjustability of the screening are important. This allows the users to feel more in control of their environment and allows them to determine the exact degree of shading or admission of daylight.

5.3.2.1 Curtains

Full-length curtains have the major drawback that, once drawn, they cover the entire window thus cutting out not only the bright sky but also the view. With changing sunlight conditions, the curtains will normally need to be drawn forwards and backwards across the entire window. To avoid the curtains obscuring part of the window when open, over-runs of track should be provided to store the curtains away from the window opening.

To keep some contact with the outside environment, curtains should not be totally opaque, but rather be of dense, translucent fabric. The colour of curtains should be light, with a material reflectance greater than 0.5, so that they do not present too great a luminance contrast with the surrounding walls once daylight has faded. Where the curtains are likely to be lit directly by sunlight, there is a danger of the material becoming too bright and appearing as a bright image in display screens. Here the material should have a close weave and have a transmittance less than 0.1.

5.3.2.2 Vertical louvre drapes

These are similar to curtains in that they generally need to be drawn across the entire window to be effective, but have the advantage that the louvres may be part opened. This can help vary the lightness of the louvres by allowing some daylight to inter-reflect through them, but may cause striped reflections on display screens facing the windows. If no display screens are positioned to one side of the window, then office users on that side can open the louvres in that direction to allow daylight in and a view out. On the other side, the display screens and their users, are still screened from the bright sky by the angle of the louvres. The louvre angle may need to be altered during the day as the sun moves across the sky.

The material of the louvres should conform to the reflectance and transmission characteristics given above for curtains.

5.3.2.3 Horizontal (Venetian) blinds

These, unlike curtains or vertical louvres, can be useful when part lowered. When part way down the window, they can cut off the bright sky whilst allowing a view out. The major drawback is that, if they are made of a glossy material, they may transmit bright highlights into the interior by inter-reflection and may cause a striped reflection on display screens facing the windows (Figure 42).

Horizontal blinds should have a matt surface finish and be of a light colour with a surface reflectance of greater than 0.5. The type of blade with small perforations can allow more of a feeling of contact with the outside world when the blind is fully lowered. Figure 42 shows a special type of Venetian blind where the bright blades are being used to bounce daylight and sunlight up onto the ceiling.

5.3.2.4 Roller blinds

These can be an inexpensive and effective solution to existing problems with window glare. They have the advantage of being able to be part drawn to shield the bright sky. The material of the roller blinds should conform to the same reflectance and transmission characteristics as for curtains. Figure 43 shows how bright the blinds can get with sunlight hitting them.

5.3.2.5 Internal light shelves

The internal light shelf is a specialised form of overhang. It consists of a light-reflective shelf part way down the window. Such shelves can also be external or partly internal and external. They are designed to shade the areas of the office space by the windows while reflecting daylight and sunlight from the reflective upper surface up onto the ceiling deeper in the space. This helps to redistribute the daylight away from the generally over-lit periphery deeper into the space, thus reducing the contrast in the space. To maintain the effectiveness of the system, regular cleaning is needed. Some additional form of screening is likely to be needed above the shelf to restrict the bright sky and high sun angles.

In order to avoid areas of ceiling near the window becoming too bright (greater than 1500 cd/m^2) or sunlight penetrating directly into the building through the gap above the shelf, it is vital to study the geometry of the shelf in relation to the yearly sun paths. Reference to CIBSE Lighting Guide 10 *Daylighting and window design*⁽¹⁵⁾ should be made. The relative benefits and problems of internal and external shelves need to be assessed.



Figure 43 Sun hitting blinds can be reflected on screen

5.3.3 External window shading options

Although a number of external window screening systems are available, they tend to be rather expensive and cause a significant change in the external appearance of the building. These rarely offer any internal control and adjustability, and this can leave the users feeling less able to control their own environment.

External systems of screening include awnings, structural overhangs or light shelves. The advantages and drawbacks of each method are looked at below.

- 5.3.3.1 Structural overhangs For obvious reasons, this is a method that must be considered at the outset of a project. Overhangs act to shield the window from high bright-sky areas. Overhangs cannot, on their own, shield the users inside the room from low winter sun. To help lower the contrast between the underside of these devices and the sky beyond, they should have as light a surface finish as possible.
- 5.3.3.2 Fixed louvres or grilles These are solutions that need to be considered early on in a building's design. Each device acts in the same way: to shield the window from high bright sky areas. They are generally fixed and are unable to shield the users inside the room from low winter sun. Mechanised louvres need regular maintenance if they are to operate successfully over the long term, but have the advantage of being able to maximise the amount of daylight available while restricting lower sun angles.
- 5.3.3.3 Awnings These can be fixed or moveable. Where fixed, they have similar effects to structural overhangs although are more easily altered or replaced. Automated awnings can be used, but careful setting up and regular maintenance are needed. The awnings can be totally opaque or have some translucency to allow a broken image of the high sky. This would make users of the spaces being shaded aware of the sun's movement during the day but remove the worst of its heat and glare. To help to reduce the contrast between the underside of the awnings and the sky, they should be of as light a colour as possible. In areas with potentially high wind speeds, automatic sensing of wind speed and retraction of the awnings will be needed.
- 5.3.3.4 External light shelves An external light shelf consists of a light-reflective shelf part way down the window. Such shelves are designed to shade the areas by the windows while reflecting daylight and sunlight from the reflective upper surface up onto the ceiling within the space. This helps to redistribute the daylight away from the generally over-lit periphery deeper into the space, thus reducing the contrast in the space. To maintain the effectiveness of the system, regular cleaning is needed. Some additional form of screening is likely to be needed for the window area above the shelf to restrict direct sun penetration.
- To avoid areas of ceiling near the window becoming too bright (greater than 1500 cd/m²) or sunlight penetrating directly into the building through the gap above the shelf, it is vital to study the geometry of the shelf in relation to the yearly sun paths. Reference to CIBSE Lighting Guide 10: *Daylighting and window design*⁽¹⁵⁾ should be made. The relative benefits and problems of internal and external shelves need to be assessed.

6 Detailed room design information

The following sub-sections provide detailed design notes on individual room types that you are likely to find in an office building. Individual information is given on the types of tasks that are likely to be carried out in these spaces and the types of lighting that are normally suitable.

Obviously, each specific type of building influences the exact form of lighting in a particular room and each client may have a house style that will influence design. In other words a meeting room in a merchant bank is likely to need a different style of lighting from that for an identical room in an advertising agency. The first may be conservative and restrained; the latter brash and exciting. However, both rooms still need lighting for the participants to be able to see each other, to judge reactions of others and to read paperwork and perhaps view small-scale presentations.

These room types are grouped under two main headings: primary office spaces, which includes areas such as open-plan, deep-plan and cellular offices, and secondary spaces, which includes archives, tea points and meeting rooms. There are also two sections that cover the vital circulation spaces, such as corridors, stairs and lift lobbies and back-of-house areas, such as plant rooms and storerooms.

External systems of screening include awnings, structural overhangs or light shelves. The advantages and drawbacks of each method are looked at below.

- 5.3.3.1 Structural overhangs For obvious reasons, this is a method that must be considered at the outset of a project. Overhangs act to shield the window from high bright-sky areas. Overhangs cannot, on their own, shield the users inside the room from low winter sun. To help lower the contrast between the underside of these devices and the sky beyond, they should have as light a surface finish as possible.
- 5.3.3.2 Fixed louvres or grilles These are solutions that need to be considered early on in a building's design. Each device acts in the same way: to shield the window from high bright sky areas. They are generally fixed and are unable to shield the users inside the room from low winter sun. Mechanised louvres need regular maintenance if they are to operate successfully over the long term, but have the advantage of being able to maximise the amount of daylight available while restricting lower sun angles.
- 5.3.3.3 Awnings These can be fixed or moveable. Where fixed, they have similar effects to structural overhangs although are more easily altered or replaced. Automated awnings can be used, but careful setting up and regular maintenance are needed. The awnings can be totally opaque or have some translucency to allow a broken image of the high sky. This would make users of the spaces being shaded aware of the sun's movement during the day but remove the worst of its heat and glare. To help to reduce the contrast between the underside of the awnings and the sky, they should be of as light a colour as possible. In areas with potentially high wind speeds, automatic sensing of wind speed and retraction of the awnings will be needed.
- 5.3.3.4 External light shelves An external light shelf consists of a light-reflective shelf part way down the window. Such shelves are designed to shade the areas by the windows while reflecting daylight and sunlight from the reflective upper surface up onto the ceiling within the space. This helps to redistribute the daylight away from the generally over-lit periphery deeper into the space, thus reducing the contrast in the space. To maintain the effectiveness of the system, regular cleaning is needed. Some additional form of screening is likely to be needed for the window area above the shelf to restrict direct sun penetration.
- To avoid areas of ceiling near the window becoming too bright (greater than 1500 cd/m²) or sunlight penetrating directly into the building through the gap above the shelf, it is vital to study the geometry of the shelf in relation to the yearly sun paths. Reference to CIBSE Lighting Guide 10: *Daylighting and window design*⁽¹⁵⁾ should be made. The relative benefits and problems of internal and external shelves need to be assessed.

6 Detailed room design information

The following sub-sections provide detailed design notes on individual room types that you are likely to find in an office building. Individual information is given on the types of tasks that are likely to be carried out in these spaces and the types of lighting that are normally suitable.

Obviously, each specific type of building influences the exact form of lighting in a particular room and each client may have a house style that will influence design. In other words a meeting room in a merchant bank is likely to need a different style of lighting from that for an identical room in an advertising agency. The first may be conservative and restrained; the latter brash and exciting. However, both rooms still need lighting for the participants to be able to see each other, to judge reactions of others and to read paperwork and perhaps view small-scale presentations.

These room types are grouped under two main headings: primary office spaces, which includes areas such as open-plan, deep-plan and cellular offices, and secondary spaces, which includes archives, tea points and meeting rooms. There are also two sections that cover the vital circulation spaces, such as corridors, stairs and lift lobbies and back-of-house areas, such as plant rooms and storerooms.

The lighting levels given are for standard tasks carried out in that area by people with normal eyesight up to about 40 years of age. If the task is more complex than normal, has a lower contrast, is safety critical or is carried out by older people, then higher lighting levels may be required. If the tasks are less onerous than normal, are simpler, have a high contrast or are carried out by young people, then lower lighting levels may be justified.

The limiting glare rating shown is the maximum discomfort glare, expressed as a Unified Glare Rating (UGR), permitted for that operation.⁽¹⁷⁾ See the *Code for Lighting*⁽⁴⁾ (CD version only) for definitions and application of UGR.

6.1 Primary office space

The primary office space is that used for the normal office work of the company. It usually consists of a mixture of cellular offices and open-plan space. The cellular space will vary from small, single-person cellular offices to larger executive or multi-person cellular offices where groups work together.

Open-plan space will vary in size but may be categorised as normal open-plan space where all the working area is near enough to windows to be regarded as being day-lit. Where the space becomes remote from the windows, it is referred to as 'deep-plan' space and needs special care if the users positioned away from the windows are not to be left feeling deprived of daylight.

A very wide range of tasks may be carried out in an office. It is possible that material of poor contrast will be read, drawings may be examined, prepared or amended, references researched and consulted etc. as well as less onerous visual tasks being carried out. It is very likely that most workstations in any general office will or might be equipped with display screens for word processing, data manipulation, multimedia or financial use. The lighting must be suitable for these screens.

Most general office work can be lit by a well-diffused overall coverage from the lighting installation, but additional lighting for visual interest may be needed. For some offices or tasks, the vertical plane illuminance should be considered as well as the more customary illuminance on the horizontal plane; for instance wall charts and notice boards.

6.1.1 Open-plan offices

Recommended maintained illuminance (lux):	300 for purely screen based work or 500 for mixed or mainly paper-based tasks.
Limiting glare rating	19

Such space can be used for a wide variety of purposes and can be laid out with fixed desk and partition systems or have desks that are constantly being re-configured for new projects or changing work patterns. The space planning flexibility needs to be established with the client, developer or user group. This will help determine any special lighting needs and the likely effect of any partitions on both the illuminances and shadowing. The degree of flexibility may also influence the decision to use a flexible lighting system and whether a control system is justifiable or preferred.

Most speculative office space is designed as totally open-plan with likely partitioning plans for cellular offices indicated. Where there is a known user, partitioning layouts may be available but future flexibility may still be required. The lighting design will need to take into account these possible partition arrangements and allow for suitable task lighting levels and uniformities in a range of cellular office modules from any fixed lighting grid. See section 3.3.3 'The effect of re-locatable walls on lighting levels' for more information.

The lighting needs to be controlled in such a way that distinct areas of the office can be lit only when needed, and designated 'corridor' routes can be left lit when the space is occupied. Such controls can vary from sophisticated automatic control systems with local hand-held controllers to local groups of wall switches. Whatever the form of control, it must be of a form that relates to the layout of the luminaires and can be readily understood by the users of the space. It will also need to comply with the requirements of Part L of the Building Regulations.⁽³⁾

6.1.2 Deep-plan areas

Recommended maintained illuminance (lux):	500 or 750 (see below)
Limiting glare rating	19

'Deep plan' areas of an office can be defined as those more than 6 m away from the window walls. It will probably be necessary for these central core areas of deep-plan offices to be lit continuously by electric lighting, since natural light does not penetrate sufficiently.

Those working in the central core areas – where the daylight factor will be significantly less than 2% – will have a lower overall lighting level as they will have little benefit from daylight. To offset this and to reduce the contrast with surfaces illuminated by natural daylight nearer the perimeter, an increased level of illumination should be provided from the electric lighting. Generally this should be one step higher in the normal illumination scale. Thus for a general lighting level of 300 lux in the area by the windows the core area should be lit to 500 lux; for a 500 lux general lighting level 750 lux should be provided in the core area.

Where there is a control system, this higher light level should be reduced as daylight levels by the perimeter reduce. When daylight has faded, there is no reason to provide more light in the core area than near to the windows.

Particular attention should be paid to lighting walls and other vertical surfaces adequately to minimise contrasts between them and brightly lit surfaces adjacent to windows. Variation in colour and texture in the general decor can also help here, provided that dark surfaces and high contrasts are avoided.

Control of daylight by blinds or curtains is also helpful in reducing glare from windows. Deep-plan spaces benefit from lighting controls acting on rows of luminaires parallel to the window by improving the uniformity of light across the space. See section 5.3.2 'Internal window shading options' for more advice.

6.1.3 Cellular offices

Recommended maintained illuminance (lux):	300 for purely screen based work or 500 for mainly paper-based tasks.
Limiting glare rating	19

These can be fixed office spaces or partitioned spaces. They may be for a single user or for a group of users. Where there are re-locatable partition walls, the lighting within the room is usually the same as that outside to allow the walls to be moved without having to change the luminaires. Where there are fixed walls, especially in older buildings and in senior managers' offices, there is more scope to vary or tailor the lighting to suit the specific types of task being carried out in the room, its character or the needs of the room occupant.

With the smaller office sizes there is less of a problem with potential reflections of the room lighting in any display screens, as the room is unlikely to be long enough for there to be luminaires visible in any normally orientated screen. Where there are plain glass partitions this may not be so. See section 4.6.2 'Direct lighting and display screens' for more advice.

Most speculative office space is marketed as totally open-plan with likely partitioning plans for cellular offices indicated. The lighting design will need to take into account these possible partition arrangements and allow for suitable task lighting levels and uniformities in a range of office modules from any fixed lighting grid. See section 3.3.3 'The effect of re-locatable walls on lighting levels' for more information.

Each enclosed office needs its own means of controlling the lighting in that space. This can be by a separate controller, as part of a central automatic programmable lighting system, or as a simple local light switch.

6.1.4 Graphics work stations

Recommended maintained illuminance:	300 Lux
Limiting glare rating	19

A graphics workstation can take many forms, but normally consists of a digitiser platen or drawing board and a large high-definition colour monitor. Occasionally there will be two screens – one screen to display the graphics image and the other to display text for menus and control. The digitiser and the graphics screen present the main problem for the lighting designer.

If small, the digitiser board is usually located to one side of the keyboard. If large, it is often positioned at right angles to the desk containing the screens and is used almost vertically by some operators. As drawing work itself is rarely carried out on such boards, high levels of task lighting are not normally required. The task normally performed here is to move a digitiser ‘mouse’ across the sketch or drawing to strategic points where a button on the ‘mouse’ is pressed. This informs the drawing program where on the digitiser the point is. For a drawing of normal clarity, 300 lux on the digitiser surface is sufficient for this task. Supplementary lighting should be provided for viewing any poor-quality copy drawings. If normal drafting work is to be carried out at the same position, supplementary lighting to increase the level to 750 lux should normally be made available. However, care must be taken in the selection and positioning of any such task lights to avoid direct or indirect glare to adjacent workers.

The operator will normally be looking from the digitiser to the graphics screen to ensure that the graphic image being built up is correct. Reference to the keyboard and possibly to a control screen or a flat keyboard at the side of the digitiser board will also need to be made. As can be seen, the range of visual tasks is quite wide and can involve the user in some movement and in frequent changes of view. For this reason it is advisable to keep the luminance range within the workstation and in the immediate surroundings within a range of 1 to 10.

With the digitiser board illuminance at about 300 lux, the luminance will be approximately 70 cd/m². The luminance range from background walls, to desk, to screen to keyboard should then, ideally, all lie in the range 20–200 cd/m². This can be achieved by aiming for a fairly constant level of illuminance on the desk and vertically on surrounding walls. The average reflectance of these major surfaces should be kept within a 5:1 range. To achieve a constant illumination over an area both horizontally and vertically, lighting with a significant indirect lighting component is recommended. The soft, even illumination from indirect lighting also helps to avoid distracting shadows on the digitiser board.

6.1.5 Dealing rooms

Recommended maintained illuminance:	300-500 lux
Limiting glare rating	19

By dealing rooms we are referring to large open-plan or deep-plan areas where a large number of dealers work at multi-screen workstations. The visual task includes the recognition of data displayed on visual display terminals, input via keyboards and keypads, processing of hand- and machine-written documents and, most importantly, communication between staff. A dealer normally needs to be able to see the others in his/her group so that they can co-ordinate deals and trades, and sometimes respond rapidly to hand and facial signals to close or delay a deal.

Thus the lighting problem is worse than for normal workstations because the multi-screen arrangements mean that some of the screens may be mounted at unfavourable angles with respect to the lighting and the need to light faces means that light has to flow across the space. The opportunity for specular reflections in some of the screens is therefore greater.

It is difficult to provide satisfactory lighting using direct light alone in most dealing rooms. To minimise possible reflections in the many screens, the luminance needs to be limited at high angles from the luminaires. Unfortunately, this will then restrict the flow of light across the space that would light the faces of other dealers. Using some indirect light adds back some soft general light to the space without generally adding to the risk of undue screen reflections.

Great care must be taken when positioning luminaires to prevent bright

images being reflected towards the viewer from display screens, keyboards, key-pads etc. The greater are the angles at which screens are inclined away from the viewer, the more onerous this restriction becomes.

Unrestricted daylight in dealing rooms can upset the controlled environment. Patches of high luminance may result from reflected light or, worse, there may be direct views of high-brightness cloud.

Windows should therefore be considered for their visual aspect rather than as a contribution towards lighting the space. The luminances of windows and adjacent walls should be similar to those of the remaining walls. See section 5.2 'Daylight and display screens' for more guidance.

6.1.6 Executive offices

Recommended maintained illuminance:	300-500 lux
Limiting glare rating	19

In office buildings, what constitutes an executive office will vary as much as the roles of workers with the term 'executive' in their job titles. In such rooms there would usually be additional space for meetings, entertaining or for informal discussions as well as space for standard office tasks. The lighting needs to be adaptable to suit the various functions and may need to reflect a higher level of quality in the finishes to the room. This can be achieved by simple upgrading in finishes to trims on the lights or by the addition of extra lighting to artwork or furniture. See section 6.1.3 'Cellular offices' and 6.2.1 'Meeting rooms' for general lighting advice. See Figure 44.

Figure 44 A number of different lights are used to produce a relaxed atmosphere



6.2 Secondary office space

Secondary office spaces are those areas used to back-up the normal office work of the company. These occur in most office buildings but in smaller ones the functions may be combined, such as having a small library of reference books in a meeting room.

6.2.1 Meeting rooms

Recommended maintained illuminance (lux):	300 for normal meetings, 500 where more intensive reading and writing is carried out.
Limiting glare rating	19

These are small- to medium-sized rooms generally used for short or informal meetings. For larger spaces see section 6.2.3 'Conference rooms'. The lighting needs to provide a flow of light across the space to light people's faces so that their reactions can be better judged and to aid those who may need to lip-read. However, this flow must not be so great as to cause glare. Combined direct/indirect luminaires often prove ideal, since they provide good working light over any table and soft general lighting to improve modelling. Dimming is usually invaluable, as various visual presentation systems may be in use in the room.

Wall washing, on a separate dimmed circuit, can be useful to highlight any wall displays or presentation stands (see Figure 45).

Figure 45 Meeting room showing use of downlights. The bright flash of the downlights close to the end wall may be distracting



6.2.2 Training rooms



Figure 46 Teaching/training room

Recommended maintained illuminance (lux):	300 for mainly presentation and note-taking type training or 500 for more detailed study and writing-based training.
Limiting glare rating	19

These rooms normally fall between meeting rooms and conference rooms in size, although they may be used for one of these other purposes as well. In training rooms there is usually a need to provide lighting onto areas where trainers make presentations to the audience. The lighting should also provide controllable light down onto the audience area to allow note taking and to light the audience's faces. However, this light must not cause glare. Some training rooms are set up as miniature versions of a main office space and as such should be lit in a similar way.

Dimming is usually invaluable as various visual presentation systems may be in use in the room. Wall washing, on a separate dimmed circuit, can be useful to highlight any wall displays or presentation stands. Lighting controls should be simple to understand and be well labelled (see Figure 46).

6.2.3 Conference rooms

Recommended maintained illuminance (lux):	300 for normal meetings, 500 where more intensive reading and writing is carried out.
Limiting glare rating	19

These rooms often have fixed seating and are larger than those dealt with in the sections on meeting rooms and training rooms, although they may be used for one of these other purposes as well. In conference rooms, there is a need to provide adjustable lighting onto areas where lecturers or speakers make presentations to the audience. Lighting over the audience area is needed to allow for note taking and reference to notes or speakers' materials. Dimming is usually essential, since various visual presentation systems may be in use in the room. Wall washing, on a separate dimmed circuit, can be useful to highlight any wall displays or presentation stands.

Lighting controls should be simple to understand, well labelled and be duplicated by the speaker's position, at the back of the room and in any projection room.

See also the CIBSE Lighting Guide 5: *The visual environment in lecture, teaching and conference rooms*⁽¹⁸⁾ for more details.

6.2.4 Board rooms



Figure 47 Board room

Recommended maintained illuminance (lux):	300 for normal meetings, 500 where more intensive reading and writing is carried out.
Limiting glare rating	19

These rooms may also be used as meeting rooms or training rooms. In most board rooms the tasks are similar to those carried out in meeting rooms but there is a need to provide higher quality and more adaptable lighting, as the space needs to have a more 'exclusive' feel about it. See section 6.1.6 'Executive offices' for more information on this aspect. Some board rooms may also be used as executive dining rooms either daily or just when there are formal board meetings (see Figure 47)

Dimming is usually invaluable as various visual presentation systems may be in use in the room. Wall washing, on a separate dimmed circuit, can be useful to highlight any wall displays or presentation stands. See also the CIBSE Lighting Guide 5 *The visual environment in lecture, teaching and conference rooms*⁽¹⁸⁾ for more details on lighting for presentation.

6.2.5 Reprographics rooms

Recommended maintained illuminance (lux):	300 vertical on reprographics equipment, 300 horizontal on all collating, binding and dispatch tables.
Limiting glare rating	22

In the modern office, a reprographics room is where large-scale copying and collation of documents takes place. Sometimes, specialists work in these rooms and documents and files needing processing are passed to them. Tasks carried out may include copying of papers and drawings, collating, trimming and binding of documents and possibly labelling and dispatch back to the originating departments. The lighting therefore needs to provide good vertical illumination around printing and copying machines and good even illumination across workbenches where detailed binding may be taking place. In some areas task lighting may be needed.

6.2.6 Libraries/information centres

Recommended maintained illuminance (lux):	200 vertical on bookcase right down to bottom shelf, 300 general, 500 on reading desks and counters.
Limiting glare rating	19

The lighting needs to provide a pleasant environment in which to select books and periodicals, refer to screen-based data sources and to sit and read and make notes. These spaces in office buildings are often rearranged over time so that the lighting needs to be flexible enough to cope with lighting vertical book stacks as well as horizontal desks, display screens, microfiches and seating areas.

6.2.7 Archives/document stores

Recommended maintained illuminance (lux):	300 for storage and selection of small items, 200 vertical on fronts of shelving.
Limiting glare rating	25

These spaces can vary in size and sophistication, from simple rooms holding local department documents to central archives where documents come in from a widely dispersed set of departments or buildings and where detailed labelling, storage and retrieval system can operate. Such rooms are often full of shelving with boxes or spaces for documents, data or samples. It is essential to ascertain from the client the type and complexity of the items being stored in each space

designated as an archive, and details of the heights and locations of any shelving or wall storage units.

Where the room is to have shelving or wall storage units, the room effectively shrinks in lighting terms. If a 3 m by 4 m room is to have 0.5 m shelving around the walls then, in lighting terms, the room becomes a 2 m by 3 m space as the light needs to be within the central volume so that the light illuminates the fronts of the shelving. There is rarely any point having lights positioned above the storage system. Where mobile storage shelves are in use, the lighting needs to be arranged so that whichever aisle is open the shelves on both sides are well lit down right to the bottom. In large areas a control system is recommended so that the lighting is only on above the open aisles as well as the access space in front of the mobile racking.

If the archive is used to house historic documents conservation issues may arise. See CIBSE Lighting Guide 8: *Museums and art galleries*.⁽¹⁹⁾

6.2.8 Tea points/ rest rooms

Recommended maintained illuminance (lux):	200 general, 300 for serving and preparation areas.
Limiting glare rating	22

These minor but essential spaces in offices need lighting for two purposes. The lighting around the tea-making areas and any related sink or food-preparation areas needs to provide the right quality and quantity of light. However, the lighting also needs to mark out the area as a social area rather than just part of the office space. Studies have shown that such informal areas are where a lot of office networking and information exchange takes place. Indeed, some companies, where information or ideas exchange between working groups or departments is particularly valuable, provide comfortable seating and even social recreational games to facilitate such exchange.

6.2.9 Sick bays/medical rooms

Recommended maintained illuminance (lux):	300 general, 500 where medical examination may be needed.
Limiting glare rating	19 (16 towards practitioner for medical examination)

These rooms may vary from just a quiet space for staff to go and sit if feeling unwell to full medical rooms with beds, examination facilities and a resident nurse. The lighting generally needs to provide a quiet attractive ambience, since occupants may be shocked or distressed. Adjustable wall or table lights may be needed for examination. Consult with company medical or personal staff for an exact brief on the extent of medical facilities needed.

6.2.10 Canteens/ restaurants

Recommended maintained illuminance (lux):	200 general, 300 over serveries, 500 in kitchens.
Limiting glare rating	22

The lighting needs to provide an attractive ambience while providing sufficient light to eat by and to light the faces of those around each table. Lighting therefore needs to provide a good flow of light across the space from luminaires that are both functional and attractive. Dimmable lighting may be needed if the area is to be used in the evening for corporate functions or dining.

The servery area needs increased lighting to ensure safety and to allow easy identification of food. Some servery counter units have integral lighting. Check with the client/catering suppliers/concession about what is being provided.

Kitchens and areas where food is prepared should have sealed luminaires for easy wiping down (even possibly hosing down) and to ensure that any glass from broken lamps or dust/dead flies from diffusers do not fall into food below.

6.3 Circulation areas

These areas are the routes that link the various parts of the building together. They often provide the first impression for visitors and need to be safe and pleasant to walk through.

6.3.1 Entrance halls/reception

Recommended maintained illuminance (lux):	200 general, 300 over reception desks and seating areas.
Limiting glare rating	22

This area is normally the first to be seen by visitors to the building and as such should create the appropriate impression. It is likely that a leading advertising agency would require a different lighting approach from that sought by a firm of city lawyers. The lighting impression needs to work during the day, when there may be a high level of daylight flowing into and across the space, and at night when the lighting needs to stand on its own. Where there are large street front windows, the lighting may need to provide effectively a 'shop window' effect to project the right impression to passers by or just to display the company's products (see Figure 48).

Figure 48 Reception area showing a range of lighting effects



Where there are large areas of windows around the entrance hall, the lighting level inside follows the fluctuating levels outside. However, where there is little daylight in the space, a higher level electric lighting may be needed to provide a transition zone for those entering from the brightly lit exterior; otherwise the space will appear dark.

Lighting over any reception or security desk needs to provide functional lighting behind the desk for handling paperwork and good multi-directional vertical illumination to provide good modelling of the face of the receptionists and the visitors. This helps those who may need to lip-read or who need to assess visitors for security reasons. A higher level of local illumination should be provided in areas where security cards or passes are to be checked. Local lighting may be appropriate around seating areas.

6.3.2 Atria

Recommended maintained illuminance (lux):	50 – 500
Limiting glare index:	Not applicable

Atria fulfil many functions – arrival points, meeting spaces, connecting spaces, work spaces, circulation, promenading, social and dining. They also provide a high-quality visual outlook to occupants of the abutting offices and can contribute to the environmental conditions within these offices. By providing access to daylight for those office workers on the 'inside' of the building, atrium buildings can offer greater efficiency in office layout and space requirements.

Planting, art works, water features, seating and reception areas are often provided within the atrium, enhancing its social function. Similarly, they are often

central to the grand circulation statement with escalators, feature observation lifts and staircases forming major elements. Dining facilities, retail and work space may also be incorporated into the atrium design

The atrium is therefore an extremely important area in a commercial development and will require lighting that is appropriate to these multi-functional provisions. It is essential that the designer be fully aware of all the functions that the atrium is to provide and their intended locations.

6.3.2.1 Natural lighting

Natural lighting is one of the primary objectives in providing an atrium space within a building. The penetration and distribution of both daylight and sunlight at all times throughout the 'natural lighting' year should be analysed and understood. This exercise will help to determine the built form, fenestration, orientation, shading devices and fabric used in the atrium and should be undertaken jointly with the architect.

These natural lighting studies should include the way that daylight and sunlight penetrate into the abutting office spaces and workplace around the atrium. Understanding this will allow the designer to maximise utilisation of daylight in these workspaces while providing screening to those spaces that will direct receive solar glare and gain. A knowledge of the amount and distribution of daylight from the atrium will also allow the designer to incorporate daylight linking to electric lighting where appropriate. These studies are particularly important in open-plan and deep-plan offices with fenestration both on an atrium-facing space and on an external façade.

Daylight factors within atria will depend on individual buildings, their location and the architectural intent. A daylight factor of 5% is suggested as the minimum required in atrium spaces where an impression of being reasonably well daylit is required. A norm of probably 10% is more usual. However, higher daylight factors are feasible but will require much greater care with the control and distribution.

6.3.2.2 Planting

Where plants species are to be installed which have a height expectancy greater than 6.0 m or enjoy high illuminances in their natural habitat, increased daylight and sunlight penetration will be required into the atrium space. In these situations, as well as preparing natural lighting profiles at the various atrium levels and within the abutting office and workplace areas, it will also be necessary to prepare a natural and electric lighting profile at the canopy location for each plant or tree. See appendix 1 'Lighting for planting' for information on how to assess and calculate the light levels required on various types of plant.

Profiling of natural lighting can be carried out using computer software at a relatively low cost if the plans and sections of the atrium are not too complex. Physical modelling under an artificial sky and sun is also appropriate, and can be used for atria having complex shapes, provided that access to these facilities is available. Manual calculation techniques of daylight modelling are not generally appropriate, except for the simplest of atrium shapes.

Physical modelling has several advantages over other techniques:

- The atrium and office interiors can be viewed from all angles;
- Different fenestration and shading devices can be easily introduced onto the model and the effects noted and measured; and
- Architectural details and varying landscape features can be easily changed

See CIBSE Lighting Guide 10: *Daylight and Window Design*.⁽¹⁵⁾

6.3.2.3 Electric lighting

Required lighting levels will vary markedly depending on the uses for which the atrium spaces are intended and their architectural design.

Those spaces used entirely as circulation and for casual social meetings may have low illuminances associated with internal 'streets' i.e. 50–100 lux. Such lighting levels will create low-brightness spaces emphasising the abutting and overlooking office and workspace interiors. Enhanced lighting to building fea-

tures, artwork and landscape in these low-brightness atria will create focal points for the users of these spaces and for occupants of overlooking offices and workspaces.

For atria used more for reception, cafes and for informal meetings, the visual appearance of the space should be of mid brightness with illuminances in the 150–300 lux range. To illuminate large atrium spaces to these values will have higher energy demands and maintenance costs, particularly if high uniformity ratios are also intended. It is usually better to light just the areas that require the higher levels, i.e. where dining facilities ‘break-out’ into the atrium or at reception and information desks etc. Outside of these localised increased-illuminance areas, ambient illuminances of 50 lux may persist.

General illuminances of 300–500 lux may be required where offices and workspaces are to be carried into the atrium. In these circumstances, great care must be taken to eliminate glare from both the natural lighting of the atrium and the electric lighting systems by the use of shading devices (static or dynamic) and luminaire design and location. Lighting to these areas could also be considered utilising ambient background levels with local lighting at the workspace.

6.3.2.4 Appearance of the atrium

The type, style and location of luminaires within an atrium space will depend greatly upon the architecture, usage and features intended and the visual brightness patterns to be achieved in the varying operational and management modes. Liaison and co-ordination between all design disciplines are therefore essential to achieve these intended brightness patterns. Decisions will be needed on which surfaces are to be illuminated, e.g. horizontal, vertical or other inclined planes; and on the colours, reflectances, specularities and degrees of mattness of these surfaces.

Manual lighting calculations will be of limited use in the prediction of brightness patterns in complex atrium spaces, and it is recommended that advanced computer lighting program software be used that also has ‘visualisation’ capabilities. The lighting designer’s attention is drawn to the brightness patterns that will exist within the overlooking offices and workspaces, as these will form part of the overall patterns exhibited by the atrium.

The location and style of luminaires to achieve the intended brightness patterns and workspace illuminance will be dependent on the nature and design of the atrium. They may be floor-mounted ‘post-top’ types, wall sconces, ceiling- or soffit-mounted or local, affixed to workspace surfaces. Direct, indirect or combination techniques are all used in the lighting of atria. The criterion which will determine both the lighting technique and the type and location of luminaire will often be maintainability, i.e. safe access facilities to luminaires to ensure constancy of the lit effect.

Many atria have overhead travelling maintenance gantries. The locations of such gantries and the manner in which they traverse the space may provide guidance as to where luminaires may be sited.

6.3.2.5 Emergency lighting

An atrium is an open space that may have escape routes crossing it, and normally needs to be lit for escape purposes across its whole length and width. This can be difficult to achieve in spaces with complex structures or unusual layouts. The lighting designer is advised to consult with Building Control and Fire Prevention Officers at an early stage to agree exit routes and lighting needs.

Emergency lighting should be considered as part of the overall lighting design and luminaire-selection process. The location of the escape lighting must be considered in the light of any smoke studies to avoid their being located where smoke will collect.

Illuminated exit signage must be considered as part of the total fire and escape strategy and the planning and location of such signage must be cognisant of:

- legibility (signs must be large enough to be read at the likely viewing distances),

- location (signs must not be above natural sight lines or be hidden by columns, down-stand beams or smoke reservoir screens), and
- architectural sensitivity.

See SLL Lighting Guide No 12: *Emergency lighting design guide*.⁽¹⁾

6.3.3 Stairs/escalators

Recommended maintained illuminance (lux):	150 on all treads.
Limiting glare rating	25

Stairs should be lit so that there is some contrast between the horizontal treads and the vertical risers. Lights can be wall mounted as long as they are above head height. Lights at tread level, either in the wall above each step or along the nosing, can be used to increase visibility. Increased levels of lighting should be provided at the entrances and exits to escalators and passenger conveyors, although many have built-in lighting below the handrail. If escalators have low-level lighting, care is needed to avoid glare from bright luminaires.

Emergency lighting needs to be well thought out so that all stair treads are lit on failure of the main lighting. Emergency lighting is also needed in any refuge areas where disabled staff or visitors wait for evacuation, as they often need to be transferred into special stair trolleys to allow them to be taken down the stairs. See SLL Lighting Guide 12: *Emergency lighting design guide*.⁽¹⁾

6.3.4 Lift lobbies

Recommended maintained illuminance (lux):	200
Limiting glare rating	22

Lift lobbies are unusual spaces in a building, as they are one of the few spaces where people wait with nothing to do but look around them. For this reason, the lighting needs to create a pleasant feel to the space as well as providing lighting to the lift controls and doorways. Note also the comments above on safe refuges.

6.3.5 Corridors

Recommended maintained illuminance (lux):	100 at floor level with good flow of light along corridor to light faces.
Limiting glare rating	25

Corridors form the arteries of most buildings they help get staff speedily from space to space but are rarely lingered in. The lighting needs to reflect the quality and feel of the rest of the office building without incurring unnecessary energy usage or glare. Where there is a fixed rhythm of doors, then the lighting can be designed to match or complement the rhythm. The luminaires along the corridor do not need to be centrally located or light it completely uniformly as long as the diversity between the minimum and maximum level on the floor is not greater than 1 to 4.

Emergency lighting and clear exit signage are needed along all corridors, especially at junctions, to aid rapid movement towards escape stairs and exits. Ensure that there is exit signage in front of all fire doors if the exit route passes through them. Those normally held open by magnetic holders release on loss of power or in the event of a fire alarm, closing off any view to exits further along the corridor. Ensure that there is emergency lighting in each compartment between such doors. See SLL Lighting Guide 12: *Emergency lighting design guide*.⁽¹⁾

6.4 Back-of-house areas

These areas are the areas that make the building function but may be unseen or unused by the office workers themselves.

6.4.1 Security/building control rooms

Recommended maintained illuminance (lux):	200 general around CCTV monitors, 300 where there is limited use of written materials.
Limiting glare rating	22

The lighting needs to be positioned to light the desks, the fronts of any control or alarm panels and any emergency equipment kept in the room. However, panels incorporating display screens need careful lighting to avoid any disabling reflections on them.

Where the room has a viewing window out into another space, so that the space or the people passing through it are monitored, then the lighting within the control room should be less than that in the space beyond the window. This will improve visibility of the space by reducing reflections back from the window. It will also reduce visibility into the control room from the space.

A high level of emergency lighting and, where available, standby lighting is required to allow easy command and control of the building during any emergencies involving mains power failure to the building. See SLL Lighting Guide: 12: *Emergency lighting design guide*.⁽¹⁾

6.4.2 Cleaners' cupboards

Recommended maintained illuminance (lux):	200
Limiting glare rating	25

These generally small spaces can have tricky tasks carried out in them such as mixing cleaning solutions and pouring them into containers or cleaning machines. There is normally a sink where the rinsing out and minor maintenance of the various types of cleaning utensil and machine is carried out. Lighting should illuminate the walls where shelving may be placed, and any sink.

While there is a temptation to put just a single light in the centre of the room, in small spaces it is often better to move a single light away from the door where few tasks are carried out. In longer rooms, two lights may be better to provide better uniformity and avoid people working in their own shadows at sinks or benches. Switch the lights at the door.

6.4.3 Plant rooms

Recommended maintained illuminance (lux):	200 general for most open plant spaces, 200 vertically on front of control panels, valve sets and instruments etc.
Limiting glare rating	25

These spaces can vary enormously in size and complexity; from simple air-handling-plant spaces with a few access hatches in the sides of large pieces of air-handling equipment, to complex boiler rooms full of pumps, control panels and valves at various heights.

Many plant rooms have trip or impact hazards and need access for maintenance or supervision of plant at different heights and locations around plant. A larger number of lower-output luminaires is usually better than trying to light the space 'economically' with a few high-output luminaires. It is often better to wall mount lighting where there is a lot of trunking, pipework or ducting criss-crossing the ceiling. Lighting is often required to the backs of certain large items of plant.

It is essential to ascertain from the mechanical and electrical engineers the types and location of plant in each space designated as a 'plant room'. There is rarely any point designing lighting for an empty plant room on an architect's layout. Many lighting positions will be obscured or even be inaccessible once the plant is installed. Sometimes, if no details are known, it is better to provide

a notional layout of lights on a plan for tendering purposes with the note that the final positions will be determined on site once the plant layouts have been confirmed.

In very large and complex spaces, the locations of light switches need careful thought. If the switches are located near to the access door, there may be a danger of personnel working in remote parts of the space being left in darkness when someone leaves without realising they are there. As locating switches throughout the space may result in them being overlooked or not used, it may be better to make the emergency lighting in the space maintained such that there will always be safety lighting on in the space.

Alternatively, a few safety lights could be distributed through the space controlled by a key switch.

Emergency lighting is required to allow safe egress from all complex plant spaces. Particular attention should be paid to obstructions, areas with low headroom and any access ladders.

6.4.4 Workshops

Recommended maintained illuminance (lux):	300 general for most open areas, 300 vertically on machines such as drills, lathes etc., 500 on workbenches where component assembly or repair is carried out.
Limiting glare rating	22/19
See <i>Code for Lighting</i> schedule sections 'Electrical industry' and 'Metal working' for more details for specialist tasks.	

These spaces can vary enormously in size and usage: from simple spaces for minor cleaning and maintenance at the end of a plant room to fully equipped facilities where process plant or machines can be serviced, repaired or even constructed from scratch. The lighting needs to provide a good quality of light over each workbench and for each machine position. Task lighting is likely to be needed along each workbench and for each machine. Note that such lighting may be an integral part of some larger machines. See also SLL Lighting Guide 1 *The industrial environment*⁽²⁰⁾ for the larger workshops.

High-frequency control gear for the lighting is recommended in all areas where people work with machines with rotating parts. This is to avoid possible stroboscopic effects where the rotating parts spin at a frequency that is a multiple of the 50 Hz mains frequency, as this can then appear stationary.

Where paint spraying is carried out, flammable liquids are used or potentially explosive dusts can collect, remote lighting or special flameproof luminaires may be needed to avoid the risk of explosion.⁽²¹⁾

A high level of emergency lighting will be needed where moving plant is in use. On power failure, the operators need to be able to move safely away from the machines and possibly to disengage or remove materials from them to render them safe. See SLL Lighting Guide 12 *Emergency lighting design guide*.⁽¹⁾

6.4.5 Lift motor rooms

Recommended maintained illuminance (lux):	200 general, 200 vertically on sides of winding machine and front of control panels etc.
Limiting glare rating	25

The lighting needs to be positioned to light the control panels and all sides of the motors, winches, winding sheaves and emergency winding equipment.

Emergency lighting is required to allow easy and safe access for manual winding to bring lift cars to a floor level in the event of mains power failure to the building.

6.4.6 Generator/ UPS rooms

Recommended maintained illuminance (lux):	200 general, 200 vertically on sides of generator, front of control panels and instruments etc.
Limiting glare rating	25

This room or plant space will house a standby generator to provide power during mains power failure or a continuously running machine as part of an uninterruptible power supply for computers or process plant, or be part of a continuously running combined-heat-and-power system that provides services to the building or site.

The visual tasks are generally to monitor running plant and to carry out routine servicing and maintenance. The lighting therefore needs to be located to light all control panels and instrumentation, as well as all sides of the machine(s) and associated fuel pumps, cooling pumps and starter system.

If the generator is used to supply the emergency lighting for a building, then it is essential that a number of emergency lights with self-contained batteries be provided within the room. Then if the generator fails to start there is light in the room to carry out a manual start or for rapid repairs.

6.4.7 Storerooms

Recommended maintained illuminance (lux):	200 for simple bulk storage, 300 for storage and selection of small items, 200 vertically for fronts of shelving.
Limiting glare rating	25

These spaces can vary enormously in size and sophistication, from simple rooms to in which keep empty packing cases to rooms full of shelving with carefully labelled bins and spaces for components or materials. It is essential to ascertain from the client the type and complexity of the articles being stored in each space designated as a 'storeroom' and to obtain details of the heights and locations of any shelving or wall storage units.

Where the room is to have shelving or wall storage units, the room effectively shrinks in lighting terms. If a 3 m by 4 m room is to have 0.5 m shelving around the walls then, in lighting terms, the room becomes a 2 m by 3 m space as the light needs to be within the central volume so that the light illuminates the fronts of the shelving. There is rarely any point having lights positioned above the storage system.

Where mobile storage shelves are in use, the lighting needs to be arranged so that, whichever aisle is open, the shelves on both sides are well lit down right to the bottom. In large areas, a control system is recommended so that the lighting is only on above the open aisles as well as the access space in front of the mobile racking.

A1 Appendix: Lighting for planting

A1.1 General

Offices and atria are 'people' spaces; they exist primarily for the benefit of users of these spaces. They are not greenhouses within which the primary purpose is to grow and sustain planting. For the office spaces themselves, it is normal to select plants which can survive under normal office lighting levels. For atria and larger entrance halls, and reception areas where special planting may be required, it is reasonable to provide special lighting to ensure the health and vitality of that planting. Selection of planting for large atrium spaces is something of a two-way process. Ideally, the plants should be selected to live within the prevailing daylight and electric lighting conditions of the space. However, to allow for special plants it is reasonable that some supplementary 'first-aid' lighting be provided to make-up any deficit between the lighting provided by the prevailing conditions and that which is required for the sustained healthy growth of the species selected.

Where such lighting would appear unnatural to the users of the space, then it should be provided outside of 'people' time. If this cannot be achieved without introducing obtrusive and glaring lighting in 'people' time, then the wrong species of plant are being proposed and they should be changed to plants with lesser requirements. Most plants also need a rest period of relative darkness for the conversion of the light stimulated photosynthesis process into carbohydrates – essential for growth and metabolic processes.

A lighting profile for each plant is therefore required, particularly for major species. This profile should indicate the total annual irradiance of luminous flux incident at the plant canopy and the composition of such luminous flux.

Therefore the profile should estimate:

- natural light – daylight and sunlight,
- ambient electric light,
- display lighting incident upon the plant for enhancement purposes,
- rest period light, and
- supplementary 'first-aid' lighting.

The total daylight component should be assessed by predicting the daylight factor occurring at the canopy of the plant in question and estimating the total luminous flux incident using BRE *Availability of daylight curves*.⁽²²⁾ Mean daily diffuse illuminance curves for each month, i.e. a set of 12 curves, are recommended, some days in the month producing less and some more.

Onto these 24-hour monthly curves can be introduced ambient electric light for the periods of ON-OFF that it is required; similarly for any display lighting that is directed at the plants for their enhancement.

The total luminous flux contained in the area under the curve can be re-distributed for a twelve-hour period and compared against horticulturists' plant requirement (horticulturists tend to specify the luminous flux irradiance requirement in kilolux for 12 hours). These monthly re-distributed 12-hour mean values can be indicated on a histogram plotted against that specified by horticulturists for the plant in question, and periods of deficit and surfeit identified.

For high daylight factor values, e.g. greater than 15%, most summer months will indicate a surfeit of luminous flux whereas in the winter, spring and autumn months a deficit will occur. It is during these deficit periods that supplementary 'first-aid' lighting will be required – supplied in the periods available that are outside of normal occupancy periods and rest periods of low illuminance. For daylight factors less than 10%, it is unlikely that major species could be grown without obtrusive lighting to occupants and users of atria.

It is impracticable to assess the total luminous flux incident upon species from direct sunlight. However, it is possible to plot on a stereographic BRE *Sunlight Availability Protractor*⁽²³⁾ the atrium glazing and fenestration taken from the plant canopy point-of-view (this will need to be carried out for each major plant). This plot illustrates:

- whether the plant is in the optimum position to receive direct sunlight;
- and
- the approximate average hours throughout the year that the plant will receive direct sunlight.

A1.2 Composition of light suitable for plant growth

Most light sources encourage plant growth, but it is necessary to consider the composition of the light. For example, 'red' light encourages spindly growth with small leaves, and a small amount of 'blue' light is needed to redress the balance. Plants do not respond to light in the same way as the human eye, as can be seen by comparing the sensitivity curve for the eye with that for plant photosynthesis (Figure 49).

The sensitivity curve of the human eye peaks at 555 nm (yellow-green) and decreases towards both the blue and the red (400 and 750 nm) ends of the spectrum. Plant sensitivity (*b* in Figure 49) peaks at 675 nm (red).

The spectral distribution of a lamp is specific to its type. This should be allowed for in selecting and quantifying the lighting to meet the needs of planting. Applying a scaling factor to the luminous flux value and then determining the amount of radiant energy available, is the best way of achieving this.

The irradiance requirements for particular plants should be obtained from horticultural suppliers. The required duration of irradiance is determined, and the lighting installation controlled to provide this daily period of exposure and the appropriate dark or 'rest' period needed by most plants.

The visual appearance of planting under variable light sources is very important in realising the overall effect of an atrium. The desired ambience in the interior and the colour rendering should be considered carefully.

Figure 49 Spectral sensitivities of the human eye and plants
a Human eye
b Typical plant

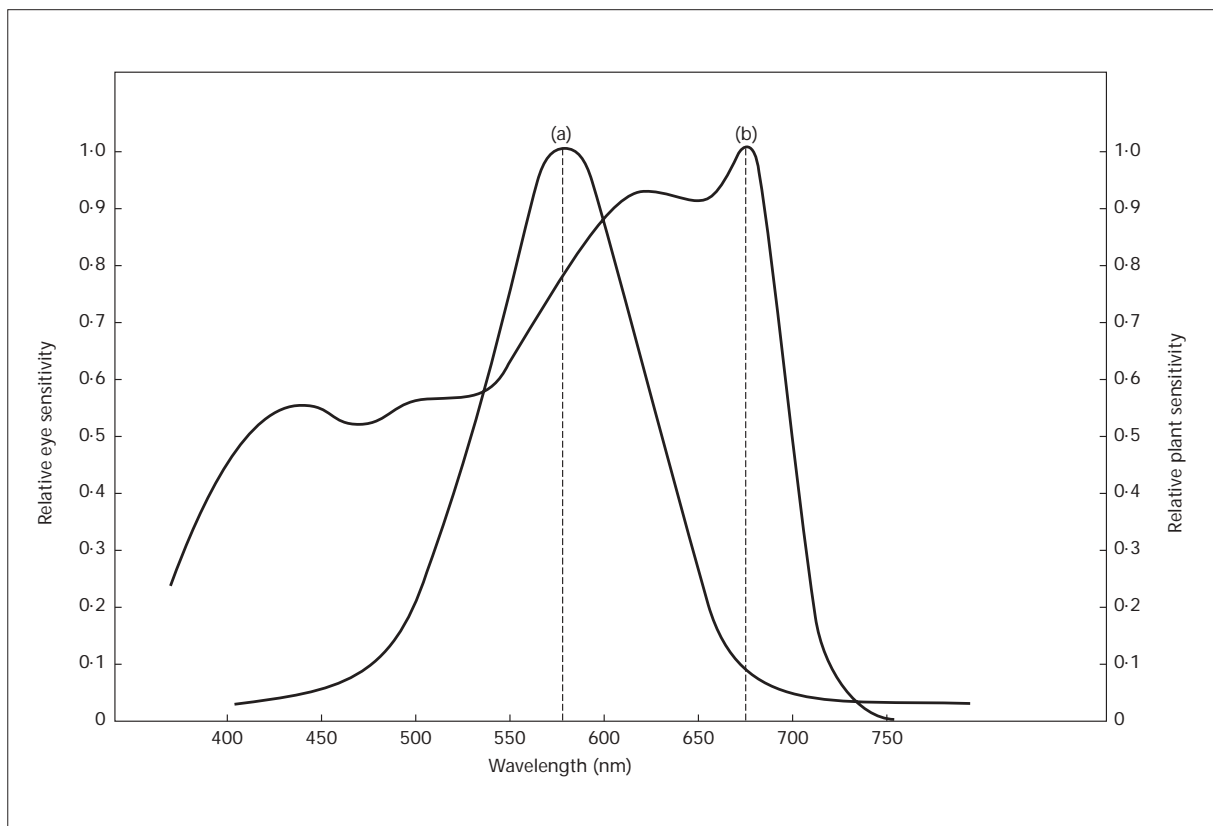

A1.3 Suitable lamp types

Incandescent lamps are unlikely to be used as the main illuminant for planting because of their relatively low efficacy, short life and high red content. An excess of red can cause spindly growth. Nevertheless, incandescent lamps can be used with care for day lengthening or to accent specific features, supplementing the main lighting installation.

Blended-light lamps are suitable for plant lighting. Their colour-rendering spectrum is very appropriate, but their application is usually limited to the local (for example, over an individual plant) due to power limitations and only a moderate efficacy.

Tubular fluorescent lamps are very suitable for fairly close work but not appropriate for long throws. Their use is mainly confined to commercial applications, where their length is an asset.

High-intensity discharge lamps are usually employed in major atria, the commonest type being metal halide. Their radiant efficiency is good, lamp life is long, and colour rendering and ambience are both satisfactory. A range of lamps is available with widely varying colour properties, and care will be needed during selection and to ensure through provision of clear maintenance instructions that replacement lamps are of the same type.

High-pressure sodium lamps are not very satisfactory for use on their own in lighting plants in atria. Colour appearance and rendering are unsuitable unless 'de luxe' or 'white' versions are used; these have power limitations and a shorter life than standard versions.

INDEX

Index Terms

Links

A

access for maintenance	21			
accommodation	63			
adaptation	63			
air distribution, need for liaison	28			
appearance of the atrium	55			
Approved Document L2	14	25	46	
archives	51			
areas where office work is carried out within other building types	13			
art works	53	55		
asymmetric distribution luminaires	33			
atria	53	60		
automatic controls	26			
average illuminance	17	36	63	
average luminance	34	36	37	39
	63			
awnings	45			

B

background lighting	15			
back-of-house areas	57			
ballast	8	25	38	63
blended-light lamps	61			
blinds	41	42	44	
board rooms	51			
book stacks	51			
brightness	21	30	40	41
	42	43	49	55
	63			
brightness contrast	63			
brightness patterns in atria	55			
BS 4800	17			
BS 8206-2	39			
BSEN 12464-1	32			

Index Terms

Links

building control rooms	57			
building finishes, reflectances of	17			
Building Regulations	14	21	25	46
building types	11			
C				
cafés in atria	55			
calculations, computerised, for atria	55			
canteens	52			
carpets, reflectance of	16			
category A and B fit out	10			
ceiling cavity reflectance	16			
ceiling colour	33			
ceiling, colour cast from carpet colour	17			
ceiling height	20			
ceiling illuminance	16			
ceiling illuminance ratio	17			
ceiling reflectance	33			
cellular office space	11	19	32	47
cellularisation	29			
central control	22			
central core areas of deep plan offices	47			
chromaticity	64			
circulation areas/spaces	15	53		
cleaners' cupboards	57			
cleaning of external light shelves	45			
client, consulting	46			
client types	8			
colour contrast	64			
colour rendering (of a light source)	16	61	63	
colour rendering index <i>Ra</i>	15	28	64	
colour stimulus	64			
colour, surface, effect on lighting	16			
colour temperature	64			
combined direct/indirect lighting	49			
complaints about working environment	39			
composition of light suitable for plant growth	61			
contrast	15	24	28	34
	36	37	38	40
	41	42	44	45
	46	47	56	64

Index Terms

Links

control panels	59			
control rooms	57			
controls, lighting	20	25	37	46
	47	50	52	
conversions from other building types	14			
conversions of existing luminaires, disadvantages	14			
copy typing	15			
corridors	56			
cove lighting	35			
curtains	43			
D				
data retrieval	15			
daylight	25	26	36	39 <i>et seq</i>
	46	47	48	53
	54	60	64	
daylight and display screens	40	41		
daylight and electric light, interaction between	40			
daylight availability curves	60			
daylight factor	47	54	60	65
daylight linking	26	54		
daylight, seasonal differences	41			
daylighting	39	54		
dealing rooms	33	48		
décor	9	11	16	21
	33			
deep-plan offices	47			
design criteria	15	34		
design brief	8			
design maintained illuminance	15			
design options for daylighting	39			
design options for electric lighting	20			
design process	7			
designing with a combination of direct light and indirect light	38			
designing with direct lighting	26			
designing with direct/indirect lighting	36			
designing with indirect lighting	33			
designing with localised lighting	22			
designing with supplementary task lighting	24			
detailed room design information	45			

Index Terms

Links

diffuse sky radiation	65			
digitiser platens	48			
dimming	15	26	30	49
	50	51		
direct lighting	15	17	19	20
	22	27	29	30
	36	37	38	39
	55	65		
direct lighting and display screens	30			
direct solar radiation	65			
direct/indirect lighting	15	18	55	
directional lighting	65			
disability glare	41	65		
discharge lamps	22	28		
discomfort glare	46	65		
display screen equipment	9	14	30	41
	42	46	57	
distribution, spatial, of luminous intensity (of a lamp or luminaire)	68			
diversity in corridors	56			
document stores	51			
drapes, vertical louvre	44			
drawing boards	48			
E				
effective floor cavity reflectance	16			
effective wall reflectance	16			
electric light and daylight interaction between	40			
electric lighting in atria	54			
emergency lighting	7	55	56 et seq	65
energy issues	15	21	25	40
entrance halls	11	53		
escalators	54	56		
escape lighting	7	8	55	65
examination lights	52			
executive offices	49			
exit signs	56			
external light shelves	45			
external lighting, control of	26			
external window shading options	44			
eye, luminance adaptation range	40			

Index Terms

Links

F

factories, office space within	13			
feature lighting	11	33		
fenestration in atria	54			
'first aid' lighting for plants	60			
fixed louvres/grilles	45			
floodlighting	26	65		
floor cavity reflectance, effective	16			
floor standing luminaires	22			
food-preparation areas	52			
free-standing luminaires	34			
fritted glass	43			

G

gantries, maintenance	55			
general background lighting	10			
general lighting	16	20	22	24
	33	47	49	65
generator rooms	59			
generator, standby	8			
glare	20	24	27	28
	32	34	41	42
	44	45	47	48
	49	50	54	55
	56	66		
glass, fritted	43			
glass, prismatic	43			
glass, reflective	43			
glass, tinted	43			
glazing options	43			
global solar radiation	66			
glossary	63			
graphics work stations	47			
grilles, fixed	45			

H

Health & Safety Executive	15			
high-definition colour monitors	48			
high frequency control gear	25	58		

Index Terms

Links

historic buildings

11

hot-desking area

9

I

illuminance (at a point of a surface)

7

10

11

14

15

16

17

21

23

24

25

29

30

36

39

42

46

48

54

55

60

66

illuminance, design maintained

15

illuminance, selection of

15

indirect lighting

15

18

19

20

21

22

33 *et seq*

36 *et seq*

48

55

66

information centres

51

interaction between daylight and electric light

40

internal light shelves

44

internal window shading options

43

irregular room shapes

30

K

keyboard, reflections of luminaires in

33

kitchens

52

known users

8

L

lamp

7

12

15

22

24

25

28

33

34

35

36

37

38

39

52

61

66

lamp types suitable for plant growth

61

landlord spaces

10

laylights

36

letting agents

10

libraries

51

lift lobbies

56

lift motor rooms

58

Index Terms

Links

light output ratio	25	34	66	
light shelves, external	45			
light shelves, internal	44			
lighting for planting	60			
lighting levels, effect of relocatable walls on	17			
lighting styles, six main	21			
lighting techniques	22			
limiting glare index/rating	16	46 <i>et seq</i>		
lip reading, need for	49	53		
Listed Building Consent	14			
lobbies	11			
local control of lighting	9			
local lighting	15	53	55	66
localised lighting	15	19	22 <i>et seq</i>	25
	33	66		
locations of indirect lighting	35			
louvre drapes, vertical	44			
louvres, fixed	45			
lumen method of calculation	36			
luminaire	8	10–12	14	15
	17	18	20–32	33–39
	41	42	46–50	52
	55–58	66		
luminaire layout with direct lighting	28			
luminaire lumens per circuit watt	25			
luminaire positions relative to partitions	19			
luminaire selection	34	37	55	
luminaire switching	37			
luminaires, thermal characteristics	15			
luminance	7	16	20–23	29
	30–43	48	49	67
luminance balance	16	40		
luminance contrast	44	66		
luminance limits, ceiling	34	37		
luminance limits, luminaire	30	37		
luminance range of daylit spaces	40			
luminance, rate of change of	30	34		
luminous ceiling	33	35		
luminous efficacy (of a source)	67			
luminous environment	20	67		

Index Terms

Links

luminous flux	60	61	67
luminous flux irradiation requirements for plants	60		
luminous intensity (of a point source in a given direction)	68		
luminous intensity distribution, luminaire	34		
M			
maintenance	29	34	45 55
maintained illuminance	15	25	29 46 <i>et seq</i>
	68		
maintenance cycle	15	68	
maximum luminance	32	34	68
mean daily diffuse illuminance	60		
medical rooms	52		
meeting rooms	49		
mobile storage shelves	52	59	
mounting height of indirect lighting	35	38	
multi-screen workstations	48		
N			
natural lighting in atria	54		
negative-polarity software	31		
new installations	8		
non-standard plugs and sockets	22		
note taking, lighting suitable for	50		
O			
observation lifts	54		
occupancy linked controls	26		
open-plan offices	46		
overhangs, structural	45		
P			
paint, reflectance	16		
paper based office tasks	15		
partitioned offices	10	46	
partitions	29		
partitions, glass	18	47	
passenger conveyors	56		
perimeters, luminaire spacing	29		

Index Terms

Links

photometric properties of luminaires for indirect lighting	34			
physical restrictions of space, effect on design	20			
plant growth, composition of light suitable for	61			
plant photosynthesis, spectral distribution needed for	61			
plant rooms	57			
planting, lighting for	53	54	60	
positive polarity software	31			
primary office space	46			
prismatic glass	43			
productivity, windows and	39			
proof reading	15			
R				
<i>Ra</i> , colour rendering index	15			
rated luminous flux (of a type of lamp)	68			
reception areas/desks	53			
reference lamp	68			
reference surface	69			
reflectance	9	14–18	21	27
	33	34	37	44
	48	55	69	
reflectances, typical, of building finishes	17			
reflections in display screens	30			
reflective glass	43			
refurbished buildings	13			
relative ceiling illuminance	16			
relative wall illuminance	16			
relocatable task lighting	9			
relocatable walls/partitions	9	10	18	20
	29	31	47	
reprographics rooms	51			
rest period lighting for plants	60	61		
rest rooms	52			
restaurants	52			
reveals, window	42			
roller blinds	44			
rooflights	41			
room décor	16			
room height	20			
room index	18	69		

Index Terms

Links

S

safety	24			
safety lighting	7	8	26	57
	69			
scallops, bright, on walls, avoiding	16	29		
screen based office tasks	15			
screening systems	15	43		
seating areas	53			
secondary office space	49			
security desks	53			
security rooms	57			
selection of illuminance	15			
self contained office buildings	11			
serveries	52			
serviced offices	12			
services options	22			
shading devices	42	54	55	
shadows, avoiding	29			
shared office accommodation	11	12		
shell and core offices	10			
sick bays	52			
small offices	11			
software running on display screen equipment	30			
solar dial time clock	26			
solar radiation	69			
sound transmission over partitions	19			
space planning flexibility	10			
spacing, luminaire	19	29	69	
spatial distribution of luminous intensity (of a lamp or luminaire)	69			
speculative developer	8			
speculative office space	10	46	47	
staircases in atria	54			
stairs	56			
standby lighting	7	8	57	69
storage furniture, over desk	29			
storerooms	59			
stores	26			
stroboscopic effect	58	69		
structural overhangs	45			

Index Terms

Links

sunlight	15	40–45	54	60
	70			
sunlight availability	60			
sunlight, direct glare from	41	42		
sunlight in atria	54			
supplementary task lighting	24			
surface reflectance	16	33		
suspended indirect luminaires	35	38		
switches in plant rooms, location of	58			
switching, luminaire	37			

T

task area	15			
task illuminance	25			
task lighting	10	15	24	46
tasks, office	15			
tea points	52			
teaching rooms	50			
technical drawing	15			
telephone sales	15			
tenants	10			
thermal gain	42			
time of day controls	26			
tinted glass	43			
track mounting	22	23		
travolators	56			
training rooms	50			
transmittance	44	70		

U

Unified Glare Rating	46			
uniformity	24	47		
uninterruptible power supply	7			
uninterruptible power supply rooms	59			
unknown user	10			
uplight, illuminance contours	23			
uplighting	33			
user types	8			
utilisation factor	18	25	36	70

Index Terms

Links

V

variety	33		
veiling reflections	41	70	
Venetian blinds	44		
ventilation, role of windows in	41		
vertical louvre drapes	44		
vertical plane illuminance	46		
view through window	39	43	
viewing windows (in control rooms)	57		
visual comfort	70		
visual field	70		
visual interest	46		
voltage spikes	22		

W

wall illuminances	16		
wall mounted indirect luminaires	34		
wall storage units, lighting for	52	59	
wall washing	30	50	51
walls in deep-plan areas	47		
water features	53		
window design	40		
window, view through	39		
window wall reflectance	16		
windows, screening	15		
windows, shape of	42		
wiring, lighting system	8		
wiring, re-using existing	14		
working plane	70		
Workplace Regulations	39		
workshops	58		