

**Guide for the Analysis, Design, and
Construction of Elevated Concrete
and Composite Steel-Concrete
Water Storage Tanks**

Reported by ACI Committee 371



American Concrete Institute®



First Printing
August 2008

American Concrete Institute®
Advancing concrete knowledge

Guide for the Analysis, Design, and Construction of Elevated Concrete and Composite Steel-Concrete Water Storage Tanks

Copyright by the American Concrete Institute, Farmington Hills, MI. All rights reserved. This material may not be reproduced or copied, in whole or part, in any printed, mechanical, electronic, film, or other distribution and storage media, without the written consent of ACI.

The technical committees responsible for ACI committee reports and standards strive to avoid ambiguities, omissions, and errors in these documents. In spite of these efforts, the users of ACI documents occasionally find information or requirements that may be subject to more than one interpretation or may be incomplete or incorrect. Users who have suggestions for the improvement of ACI documents are requested to contact ACI. Proper use of this document includes periodically checking for errata at www.concrete.org/committees/errata.asp for the most up-to-date revisions.

ACI committee documents are intended for the use of individuals who are competent to evaluate the significance and limitations of its content and recommendations and who will accept responsibility for the application of the material it contains. Individuals who use this publication in any way assume all risk and accept total responsibility for the application and use of this information.

All information in this publication is provided "as is" without warranty of any kind, either express or implied, including but not limited to, the implied warranties of merchantability, fitness for a particular purpose or non-infringement.

ACI and its members disclaim liability for damages of any kind, including any special, indirect, incidental, or consequential damages, including without limitation, lost revenues or lost profits, which may result from the use of this publication.

It is the responsibility of the user of this document to establish health and safety practices appropriate to the specific circumstances involved with its use. ACI does not make any representations with regard to health and safety issues and the use of this document. The user must determine the applicability of all regulatory limitations before applying the document and must comply with all applicable laws and regulations, including but not limited to, United States Occupational Safety and Health Administration (OSHA) health and safety standards.

Order information: ACI documents are available in print, by download, on CD-ROM, through electronic subscription, or reprint and may be obtained by contacting ACI.

Most ACI standards and committee reports are gathered together in the annually revised *ACI Manual of Concrete Practice* (MCP).

American Concrete Institute
38800 Country Club Drive
Farmington Hills, MI 48331
U.S.A.

Phone: 248-848-3700
Fax: 248-848-3701

www.concrete.org

ISBN 978-0-87031-292-2

Guide for the Analysis, Design, and Construction of Elevated Concrete and Composite Steel-Concrete Water Storage Tanks

Reported by ACI Committee 371

Atis A. Liepins
Chair

Jeffrey S. Ward*
Secretary

Kevin A. Binder
Noel J. Everard

Anthony J. Galterio
Charles S. Hanskat

Stephen Meier
Rolf P. Pawski*

Wes Pogorzelski

*Major contributors to the preparation of this report.

This guide presents recommendations for materials, analysis, design, and construction of concrete-pedestal elevated water storage tanks. Both the all-concrete tank and the composite tank, consisting of a steel water storage vessel supported on a cylindrical reinforced concrete pedestal, are included.

Concrete-pedestal elevated water storage tanks are structures that present special problems not encountered in typical environmental engineering concrete structures. This guide refers extensively to ACI 350 for design and construction of those components of the pedestal tank in contact with the stored water, and to ACI 318 for design and construction of components not in contact with the stored water. Determination of snow, wind, and seismic loads based on ASCE/SEI 7 is included. These loads will conform to the requirements of national building codes that use ASCE/SEI 7 as the basis for environmental loads or conform to the requirements of local building codes. Special requirements, based on successful experience, for the unique aspects of loads, analysis, design, and construction of concrete-pedestal tanks are presented.

Keywords: analysis; composite tanks; concrete-pedestal tanks; construction; design; earthquake-resistant structures; elevated water tanks; formwork (construction); load, dead; load, earthquake; load, live; load, snow; load, water; load, wind; load combinations; loads (forces); shear; shear strength; structural analysis; structural design; walls.

ACI Committee Reports, Guides, Manuals, Standard Practices, and Commentaries are intended for guidance in planning, designing, executing, and inspecting construction. This document is intended for the use of individuals who are competent to evaluate the significance and limitations of its content and recommendations and who will accept responsibility for the application of the material it contains. The American Concrete Institute disclaims any and all responsibility for the stated principles. The Institute shall not be liable for any loss or damage arising therefrom.

Reference to this document shall not be made in contract documents. If items found in this document are desired by the Architect/Engineer to be a part of the contract documents, they shall be restated in mandatory language for incorporation by the Architect/Engineer.

CONTENTS

Chapter 1—General, p. 371R-2

- 1.1—Introduction
- 1.2—Scope
- 1.3—Drawings, specifications, and calculations

Chapter 2—Notation and definitions, p. 371R-3

- 2.1—Notation
- 2.2—Definitions

Chapter 3—Materials, p. 371R-5

- 3.1—Materials common to both composite and concrete tank types
- 3.2—Materials specific to composite tanks
- 3.3—Materials specific to concrete tanks

Chapter 4—Construction, p. 371R-5

- 4.1—Construction common to both composite and concrete tank types
- 4.2—Construction specific to composite tanks
- 4.3—Construction specific to concrete tanks

Chapter 5—Design, p. 371R-11

- 5.1—Design recommendations common to both composite and concrete tank types
- 5.2—Design of components common to both composite and concrete tank types

ACI 371R-08 supersedes ACI 371R-98 (Reapproved 2003) and was adopted and published August 2008.

Copyright © 2008, American Concrete Institute.

All rights reserved including rights of reproduction and use in any form or by any means, including the making of copies by any photo process, or by electronic or mechanical device, printed, written, or oral, or recording for sound or visual reproduction or for use in any knowledge or retrieval system or device, unless permission in writing is obtained from the copyright proprietors.

- 5.3—Design of components specific to composite tanks
- 5.4—Design of components specific to all-concrete tanks

Chapter 6—Geotechnical recommendations, p. 371R-23

- 6.1—General
- 6.2—Foundation depth
- 6.3—Settlement limits
- 6.4—Shallow foundations
- 6.5—Deep foundations
- 6.6—Seismic recommendations
- 6.7—Special considerations

Chapter 7—Appurtenances and accessories, p. 371R-25

- 7.1—General
- 7.2—Pedestal access
- 7.3—Ventilation
- 7.4—Tank access
- 7.5—Rigging devices for steel vessel
- 7.6—Above-ground piping
- 7.7—Below-ground piping
- 7.8—Interior floors within pedestal
- 7.9—Electrical and lighting

Chapter 8—References, p. 371R-31

- 8.1—Referenced standards and reports
- 8.2—Cited references

Appendix A—Supplementary information, p. 371R-32

CHAPTER 1—GENERAL

1.1—Introduction

This document provides guidance for specifying, designing, and constructing elevated concrete and composite steel-concrete water storage tanks. Elevated tanks are used by municipalities and industry for potable water supply and fire protection. Commonly built sizes of elevated concrete and composite steel-concrete water storage tanks range from 500,000 to 3,000,000 gal. (1900 to 11,000 m³). Concrete pedestal heights range from 25 to 200 ft (8 to 60 m), depending on water system requirements and site elevation. The interior of the concrete pedestal may be used for material and equipment storage, office space, and other applications.

1.2—Scope

This document covers the design and construction of elevated concrete and composite steel-concrete water storage tanks. Topics include materials, construction requirements, determination of structural loads, design of concrete elements including foundations, design of concrete or steel tank components, geotechnical requirements, appurtenances, and accessories. Materials, design, fabrication, and construction of the steel vessel of composite steel-concrete tanks are addressed by applicable sections of AWWA D100.

Designs, details, and methods of construction are presented for the types of elevated concrete and composite steel-concrete water storage tanks shown in Fig. 1.1 and 1.2.

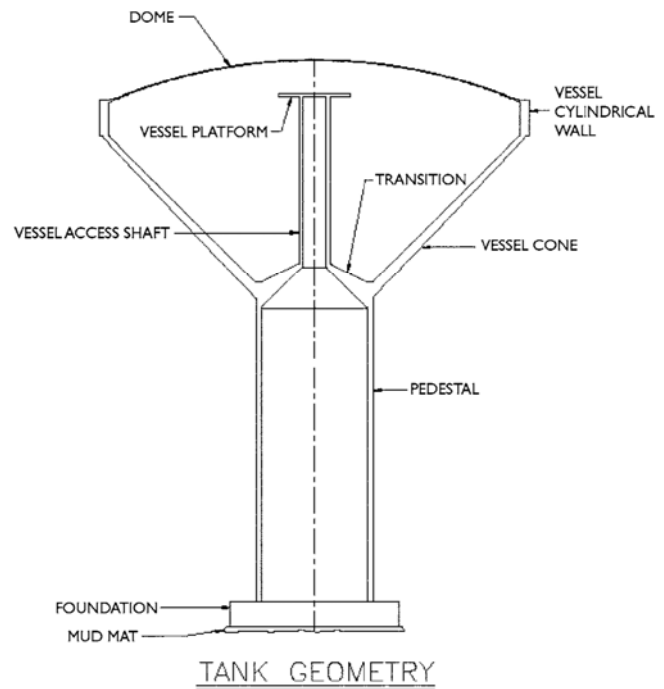

Fig. 1.1—Common configuration of elevated concrete tanks.

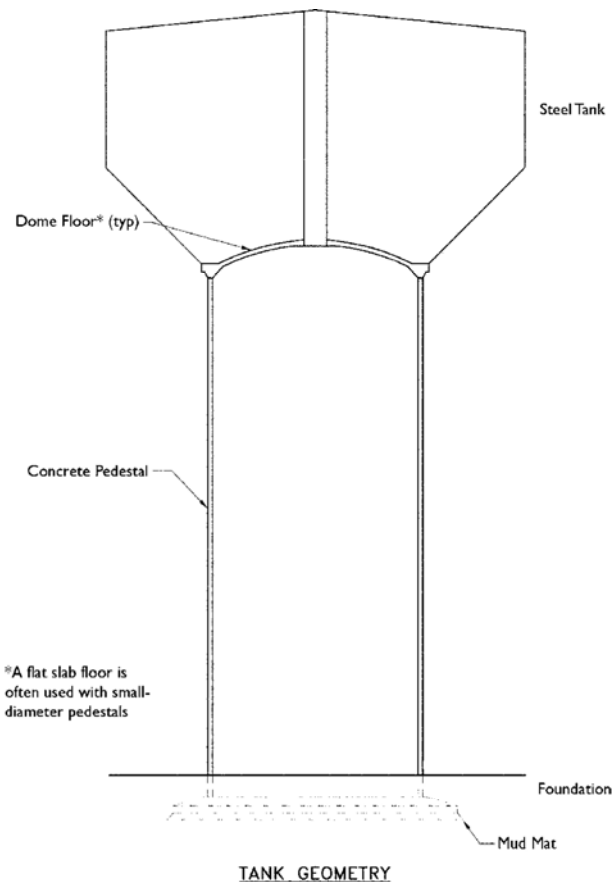

Fig. 1.2—Common configuration of elevated composite steel-concrete tanks.

This document may be used in whole or in part for other tank configurations; however, the designer should determine the suitability of such use for other configurations and details.

1.3—Drawings, specifications, and calculations

1.3.1 Drawings and specifications—Construction documents should show all features of the work, including the size and position of structural components and reinforcement, structural details, specified concrete compressive strength, and the strength or grade of reinforcement and structural steel. The codes and standards to which the design conforms, the tank capacity, and the design basis or loads used in design should also be shown.

1.3.2 Design basis documentation—The design coefficients and resultant loads for snow, wind, and seismic forces and methods of analysis should be documented.

CHAPTER 2—NOTATION AND DEFINITIONS

2.1—Notation

A_{cv} = concrete shear area of a section, in.² (mm²); [Section 5.2.2.7](#)

A_f = horizontal projected area of a portion of the structure where the wind force coefficient C_f and the wind pressure p_z are constant, in.² (mm²); [Section 5.1.2.6.2](#)

A_g = gross concrete area of a section, in.² (mm²); [Section 5.2.2.3.3](#)

A_s = area of nonprestressed tension reinforcement, in.² (mm²); [Section 5.2.2.3.3](#)

A_w = gross horizontal cross-sectional concrete area of wall, in.² (mm²), per unit length of circumference, ft (m); [Section 5.2.2.3.3](#)

b = width of compression face in a member, in. (mm)

b_d = width of a doorway or other opening, in. (mm); [Section 5.2.2.5](#)

b_v = equivalent shear wall length not to exceed $0.78d_w$, in. (mm); [Section 5.2.2.7.4](#)

b_x = cumulative opening width in a distance of b_v , in. (mm); [Section 5.2.2.7.4](#)

C_c = spectral acceleration of sloshing liquid; [Section 5.1.2.8.3](#)

C_e = eccentricity coefficient that accounts for the resultant of factored axial load being eccentric to the centroid of the pedestal thickness; [Section 5.2.2.3.3](#)

C_{es} = snow load exposure factor; [Section 5.1.2.7](#)

C_f = wind force coefficient; [Section 5.1.2.6](#)

C_s = seismic response coefficient; [Section 5.1.2.8](#)

C_{sm} = modal seismic design coefficient for mode m ; [Section 5.1.2.8.2.2.4](#)

C_{vx} = seismic distribution factor; [Section 5.1.2.8.2.1.6](#)

C_{vxm} = seismic distribution factor of the m -th mode; [Section 5.1.2.8.2.2.5](#)

c_c = clear cover from the nearest surface in tension to the surface of the flexural torsion reinforcement, in. (mm); [Section 5.1.4.2](#)

D = dead load

D_t = tank diameter at the water surface, ft (m); [Section 5.1.2.8.3](#)

d = distance from extreme compression fiber to centroid of tension reinforcement, in. (mm)

d_w = mean diameter of concrete pedestal, ft (m); [Sections 5.1.2.6.2](#) and [5.2.2.7.4](#)

E = combined effect of horizontal and vertical earthquake forces

e = eccentricity of the axial wall load, in. (mm); [Section 5.2.2.3.3](#)

e_g = vertical load eccentricity, in. (mm); [Section 5.1.2.9](#)

e_o = minimum vertical load eccentricity, in. (mm); [Section 5.1.2.9](#)

F = stored water load

F_a = seismic acceleration-based site coefficient; [Section 5.1.2.8](#)

F_i = portion of the total seismic shear V acting at level i , kip (kN); [Section 5.1.2.8.2.1.7](#)

F_v = seismic velocity-based site coefficient; [Section 5.1.2.8](#)

F_x = portion of the seismic shear V acting at level x , kip (kN); [Section 5.1.2.8.2.1.6](#)

F_{xm} = modal force at each level, kip (kN); [Section 5.1.2.8.2.2.5](#)

F_z = wind force acting on tributary area A_f , kip (kN); [Section 5.1.2.6](#)

f'_c = specified compressive strength of concrete, psi (MPa)

$\sqrt{f'_c}$ = square root of specified compressive strength, psi (MPa)

f_s = calculated stress in reinforcement at service loads for control of cracking, ksi (MPa); [Sections 5.1.4.2](#) and [5.2.1.6.3](#)

f_y = specified yield strength of reinforcing steel, psi (MPa)

G = eccentric load effects due to dead load and water

G_w = wind gust factor; [Section 5.1.2.6.2](#)

g = acceleration due to gravity, 32.2 ft/s² (9.8 m/s²)

h = height from grade to the top of the vessel shell, ft (m); [Section 5.1.2.6.2](#)

h_d = height of a doorway opening, ft (m); [Section 5.2.2.5](#)

h_f = foundation depth measured from original ground line, ft (m); [Section 6.4.4](#)

h_i = height from the base to level i for seismic force distribution, ft (m); [Sections 5.1.2.8.2.1.6](#) and [5.1.2.8.2.1.8](#)

h_r = wall thickness exclusive of any rustications or architectural relief, in. (mm); [Section 5.2.2.2.1](#)

h_s = steel vessel dome tank floor thickness, in. (mm); [Section 5.3.1.3.2](#)

h_x = height from the base to level x for seismic force distribution, ft (m); [Sections 5.1.2.8.2.1.6](#) and [5.1.2.8.2.1.8](#)

I = importance factor; [Section 5.1.2.8](#)

K_z = wind exposure coefficient; [Section A5.1.2.6](#)

k = structure exponent; [Section 5.1.2.8.2.1.6](#)

k = effective unsupported column length, ft (m); [Section 5.2.2.5.3](#)

L = interior floor live loads

g	= distance from bottom of foundation to centroid of stored water, in. (mm); Section 5.1.2.9	V_m	= portion of the seismic base shear contributed by the m -th mode, kip (kN); Sections 5.1.2.8.2.2.4 and 5.1.2.8.2.2.5
M_h	= wind overlying moment per unit of height at horizontal sections, kip-ft/ft (kN-m/m); Section 5.2.2.4	V_n	= nominal shear strength, kip (kN); Section 5.2.2.7
M_u	= factored moment, kip-ft/ft (kN-m/m); Section 5.2.2.7	V_u	= factored shear force, kip (kN); Section 5.2.2.7
M_x	= seismic overturning moment at height h_x above base, kip-ft (kN-m); Section 5.1.2.8.2.1.8	V_x	= lateral seismic shear acting at any level of the structure, kip (kN); Section 5.1.2.8.2.1.8
P	= foundation load above grade, kip (kN); Section 6.4.4	W	= wind load effect
P_{mw}	= nominal axial load strength of wall, lb (N) per unit of circumference, ft (m); Section 5.2.2.3	W_c	= weight of concrete below grade, lb (N)
P_s	= gravity service load, kip (kN); Section 5.2.1.3	W_e	= seismic effective weight, kip (kN); Section 5.1.2.8.2
P_{uw}	= factored axial wall load, lb (N) per unit of circumference, ft (m); Sections 5.2.2.3 and 5.2.2.5.5	W_i	= portion of the total mass whose centroid is at level i ; Sections 5.1.2.8.2.1.6 , 5.1.2.8.2.2.4 , and 5.1.2.8.2.2.5
p_g	= ground snow load, lb/ft ² (N/m ²); Section 5.1.2.7	W_m	= effective modal load; Section 5.1.2.8.2.2.4
p_r	= rain on snow surcharge, lb/ft ² (N/m ²); Section 5.1.2.7.2.3	W_r	= horizontal distance from eaves to center of cone, conical, or curved roof, ft (m); Section 5.1.2.7.2.3
p_s	= snow load on roof, lb/ft ² (N/m ²); Section 5.1.2.7	W_s	= weight of soil below grade, lb/ft ² (N/m ²); Section 6.4.4
p_z	= wind pressure at height z , lb/ft ² (N/m ²); Sections 5.1.2.6 and 5.2.2.4.2	W_x	= portion of the total mass whose centroid is at level x ; Sections 5.1.2.8.2.1.6 and 5.1.2.8.2.2.5
Q_a	= allowable service load capacity of a pile or pier, kip (kN); Section 6.5	w_u	= factored distributed load, lb/ft ² (N/m ²); Section 5.3.1.3.2
Q_r	= ultimate capacity of a pile or pier, kip (kN); Sections 5.2.1.3 and 6.5	z	= height above ground level, lb/ft ² (N/m ²); Section 5.1.2.6
q_a	= allowable bearing capacity of a shallow foundation, lb/ft ² (N/m ²); Section 6.4	α_c	= constant used to compute in-plane nominal shear strength; Section 5.2.2.7
q_r	= ultimate bearing capacity of a shallow foundation, lb/ft ² (N/m ²); Sections 5.2.1.3 and 6.4	δ_s	= height of sloshing wave, ft (m); Section 5.1.2.8.3
R	= response modification coefficient; Section 5.1.2.8.2.1.3	γ_s	= unit weight of soil, lb/ft ³ (N/m ³); Section 6.4.4
R_d	= mean meridional radius of dome tank floor, ft (m); Section 5.3.1.3.2	θ_g	= foundation tilt, degrees; Section 5.1.2.9
S	= larger of snow load or minimum roof live load	θ_r	= slope of a straight line from the eaves, or the 70-degree point if present, to the crown of a curved, conical, or cone roof, degrees; Section 5.1.2.7.2
S_1	= maximum considered earthquake spectral response acceleration at 1 second; Section 5.1.2.8	ρ	= A_s/bd , ratio of nonprestressed tension reinforcement
S_{am}	= seismic design spectral response acceleration at period T_m ; Section 5.1.2.8.2.2.4	ρ_g	= A_s/A_g , ratio of total nonprestressed reinforcement
S_{D1}	= seismic design spectral response acceleration for a period of 1 second; Section 5.1.2.8	ρ_h	= ratio of horizontal distributed shear reinforcement on a horizontal plane; Section 5.2.2.7.8
S_{DS}	= seismic design spectral response acceleration for short period; Section 5.1.2.8	ρ_v	= ratio of vertical distributed shear reinforcement on a vertical plane perpendicular to A_{cv} ; Section 5.2.2.7
S_s	= maximum considered earthquake spectral response acceleration at short periods; Section 5.1.2.8	Φ	= modal shape factor used for seismic analysis; Section 5.1.2.8.2.2.2
T	= force due to restrained thermal movement, creep, shrinkage, or differential settlement	Φ_{im}	= displacement amplitude at the level i of the structure when vibrating in its m -th mode; Sections 5.1.2.8.2.2.4 and 5.1.2.8.2.2.5
T_f	= fundamental period of vibration of structure, seconds; Section 5.1.2.8.2.1.3	Φ_{xm}	= displacement amplitude at the level x of the structure when vibrating in its m -th mode; Section 5.1.2.8.2.2.5
T_L	= lower bound of the period at which the long period response spectrum starts, seconds; Section 5.1.2.8.2.2.4	ϕ	= strength reduction factor
T_m	= modal period of vibration of the m -th mode, seconds; Section 5.1.2.8.2.2.4	ψ	= wall opening ratio; Section 5.2.2.7
V	= total design lateral force or shear at base of structure, kip (kN); Section 5.1.2.8.2.1		
V_b	= basic wind speed, mph (m/s); Section 5.1.2.6		

2.2—Definitions

documents, contract—a set of documents supplied by the Owner to the Contractor as the basis for construction; these documents contain contract forms, contract conditions, specifications, drawings, addenda, and contract changes.

crown—highest point of the roof at centerline of tank.

eave—highest level at which the tank diameter is a maximum or the roof slope of curved or conical roof is 70 degrees from horizontal.

foundation—a system of structural elements that transmits loads from the structure above to the earth.

foundation, deep—a foundation with a bottom elevation typically far below the soil surface that obtains its load-carrying capacity through a combination of direct bearing on soil or rock at its base and friction or adhesion on its vertical sides.

foundation, raft—a shallow foundation consisting of a continuous concrete slab, usually reinforced, placed over native soil, engineered subgrade, or to support heavy loads, and where loads are globally distributed through flexural resistance of the foundation are transmitted to the ground. Also referred to as a mat foundation.

foundation, shallow—a foundation with a bottom elevation typically near the soil surface that obtains its load-carrying capacity primarily by direct bearing on soil or rock rather than friction or adhesion on its vertical sides.

pedestal—the portion of an elevated water storage tank between the top of the foundation and the base of the water-containing portion.

pier—a slender isolated foundation member of either plain or reinforced concrete that is cast on end in the ground.

pier cap—a concrete element that transfers load from a column or pedestal to the top of one or more supporting piers.

pile—a slender structural element that is driven, jetted, or otherwise embedded on end in the ground to support a load or compact the soil. (See also **pile, composite** in ACI *Cement and Concrete Terminology* [American Concrete Institute 2008])

pile cap—a concrete element that transfers load from a column or pedestal to the top of one or more supporting piles.

ringbeam—continuous tension and flexural element tied to the top or bottom perimeter of a cylindrical structure.

roof, cone—a roof with a constant slope from the crown to the eaves.

roof, conical—a cone roof combined with a steeply sloped edge cone or a doubly curved edge segment.

roof, curved—a roof with a continuously increasing slope from crown to eaves; or the doubly curved portion of a spherical roof.

roof slope θ_r —slope of a straight line from the eaves (or the 70-degree point if present) to the crown of a curved roof, a conical roof, or a cone roof.

rustication—a shallow groove on a concrete surface formed by strips of wood or other material attached to the form to provide architectural effect.

slab-on-ground—a shallow foundation consisting of a continuous concrete slab, placed over native soil or engineered subgrade, where loads are locally distributed and transmitted to the ground. Also referred to as slab-on-grade; preferred term is slab-on-ground.

tank vessel—water-containing portion of the structure.

vessel floor—a structural concrete cone, dome, or flat slab that supports the vessel contents inside the pedestal.

CHAPTER 3—MATERIALS

3.1—Materials common to both composite and concrete tank types

3.1.1 General—Tank components not in contact with stored water should be designed in accordance with ACI 318, and as recommended in this guide.

3.2—Materials specific to composite tanks

Materials for steel vessels of composite water tanks should comply with the standards specified for design and construction in [Section 5.3.3](#).

3.3—Materials specific to concrete tanks

3.3.1 General—Materials for concrete tank components in contact with stored water should be in accordance with ACI 350, and as recommended in this guide. Concrete and related prestressed materials, waterstops, sealing materials, and coatings for outer surfaces for concrete tanks should be in accordance with ACI 373R, and as recommended in this guide.

3.3.2 Permeable grout tubes—Grout tubes should be composed of a reinforcing spiral, inner fiber membrane, and an outer protective synthetic membrane. The tube should be completely permeable for the injected sealing materials and impermeable for cement particles.

3.3.3 Polyurethane grout and accelerator—The polyurethane grout should have the ability to react with water and expand up to three times in volume.

3.3.4 Epoxy adhesives—Epoxy used for increasing the bond between hardened concrete and fresh concrete should be a two-component, 100%-solids, moisture-insensitive epoxy adhesive meeting ASTM C881/C881M, Type II, Grade 2. ACI 503.2 also contains information on this subject. The bonding agent should produce a bond strength (ASTM C882) not less than 1500 psi (10.3 MPa) 14 days after the fresh concrete is placed.

3.3.5 Shotcrete—Shotcrete in elevated concrete tanks should be in accordance with ACI 372R and 506R.

CHAPTER 4—CONSTRUCTION

4.1—Construction common to both composite and concrete tank types

4.1.1 General

4.1.1.1 Reference standards—Concrete, formwork, reinforcement, and details of the components of the concrete tank not in contact with stored water, all concrete components of the composite steel-concrete tank, and foundations should conform to ACI 318, and as recommended in this guide. Concrete, formwork, reinforcement, and details of the components of the concrete tank in contact with stored water should conform to ACI 350, and as recommended in this guide.

4.1.1.2 Quality assurance—A quality assurance plan to verify that the construction conforms to the design requirements should be prepared. It should include:

(a) Inspection and testing required, forms for recording inspections and testing, and the certifications required for the personnel performing such work. At a minimum, field testing personnel should be ACI certified as Concrete Field Technicians, and inspectors as Concrete Construction Special Inspectors; or have equivalent certification;

(b) Procedures for exercising control of the construction work and the personnel exercising such control;

(c) Methods and frequency of reporting and the distribution of reports; and

(d) The qualifications and accreditations required for the laboratory or agency providing the testing.

4.1.2 Concrete

4.1.2.1 General—Concrete mixtures should be suitable for the placement methods, forming systems, and the weather conditions during concrete construction, and should satisfy the required structural, durability, and architectural parameters.

4.1.2.2 Concrete quality

4.1.2.2.1 Water-cementitious material ratio—The water-cementitious material ratio (w/cm) should be in accordance with Table 4.2.2 of either ACI 318-05 or 350-06, as applicable.

4.1.2.2.2 Specified compressive strength—The minimum specified compressive strength of concrete should conform to the following:

Tank vessel prestressed elements.....	5000 psi (35 MPa)
Tank vessel floor, dome, access shaft and platform	4000 psi (28 MPa)
Pedestal	4000 psi (28 MPa)
Foundations and intermediate floors.....	3500 psi (24 MPa)
Slabs-on-ground	see Table 7.1

4.1.2.2.3 Air entrainment—Concrete should be air-entrained in accordance with ACI 318 or 350 as applicable.

4.1.2.3 Proportioning—Proportioning of concrete mixtures should conform to the requirements of ACI 318 or 350, as applicable, and the procedure of ACI 211.1.

4.1.2.3.1 Workability—The proportions of materials for concrete should be established to provide adequate workability and proper consistency to permit concrete to be worked readily into the forms and around reinforcement without excessive segregation or bleeding for the methods of placement and consolidation used.

4.1.2.3.2 Slump—The slump of concrete provided should be based on consideration of the conveying, placing, and vibration methods as well as the geometry of the component, and should conform to the following:

(a) Concrete without high-range water-reducing admixtures (HRWRAs) should be proportioned to produce a slump of 4 in. (100 mm) at the point of placement;

(b) Slump should not exceed 8 in. (200 mm) after addition of HRWRA and 4 in. (100 mm) before, unless the mixture has been proportioned to prevent segregation at higher slump; and

(c) The slump of concrete to be placed on an inclined surface should be controlled such that the concrete does not sag or deform after placement and consolidation.

4.1.2.3.3 Admixtures—Admixtures may be used to achieve the required properties. Admixtures should be compatible such that their combined effects produce the required results in hardened concrete as well as during placement and curing.

4.1.2.4 Concrete production—Measuring, mixing, and transporting of concrete should conform to the requirements of ACI 318 or 350, as applicable to the construction, and the recommendations of ACI 304R.

4.1.2.4.1 Slump adjustment—Concrete that arrives at the project site with slump below that suitable for placing may have water added within limits of the slump and permissible w/cm of the concrete mixture. Addition of water should be in accordance with ASTM C94/C94M. No water should be added to the concrete after plasticizing admixtures or HRWRAs have been added. Slump adjustments can be made by adding additional admixtures.

4.1.2.5 Placement—Placing and consolidation of concrete should conform to ACI 318 or 350, as applicable to the construction, and the recommendations of ACI 304R and 309R.

4.1.2.5.1 Depositing and consolidation—Placement should be at such a rate that the concrete that is being integrated with fresh concrete is still plastic. Concrete that has partially hardened or has been contaminated by foreign materials should not be deposited. Consolidation of concrete should be with internal vibrators.

4.1.2.5.2 Pedestal—Drop chutes or tremies should be used in walls and columns to avoid segregation of the concrete and to allow it to be placed through the reinforcing steel cage. These chutes or tremies should be moved at short intervals to prevent stacking of concrete. Vibrators should not be used to move the mass of concrete through the forms.

4.1.2.6 Curing—Curing methods should conform to ACI 318 or 350 as applicable and the requirements of ACI 308.1. Curing methods should be continued or effective until concrete has reached 70% of its specified compressive strength f'_c unless a higher strength is required for applied loads. Curing should begin as soon as practicable after placing and finishing. Curing compounds should be membrane forming or combination curing/surface hardening types conforming to ASTM C309.

4.1.2.7 Weather

4.1.2.7.1 Protection—Concrete should not be placed in rain, sleet, snow, or extreme temperatures unless protection is provided. Rainwater should not be allowed to increase mixing water or to damage surface finish.

4.1.2.7.2 Cold weather—During cold weather, the requirements of ACI 306.1 should be followed.

4.1.2.7.3 Hot weather—During hot weather, the requirements of ACI 305.1 should be followed.

4.1.2.8 Testing, evaluation, and acceptance—Material testing, type and frequency of field tests, and evaluation and acceptance of testing should conform to ACI 318 or 350, as applicable.

4.1.2.8.1 Concrete strength tests—At least four cylinders should be molded for each acceptance test required. Two cylinders should be tested at 28 days for the strength test. One cylinder should be tested at 7 days to supplement the 28-day tests. The fourth cylinder is a spare to replace or supplement other cylinders. Concrete temperature, slump, and air content measurements should be made for each set of cylinders. Unless otherwise specified in the project documents, sampling of concrete should be at the point of delivery.

4.1.2.8.2 Early-age concrete strength—Where knowledge of early-age concrete strength is required for construction loading, cylinders should be molded, field

cured, and tested on the appropriate day, or one of the following nondestructive test methods should be used after strength correlation data are obtained. These data are normally obtained during the mixture proportioning process:

(a) Penetration resistance in accordance with ASTM C803/C803M;

(b) Pullout strength in accordance with ASTM C900; and

(c) Maturity-factor method in accordance with ASTM C1074.

4.1.2.8.3 Reporting—A report of tests and inspection results should be provided. Location on the structure represented by the tests, weather conditions, and details of storage and curing should be included.

4.1.2.9 Joints and embedments

4.1.2.9.1 Construction joints—The location of construction joints and their details should be shown on construction drawings. Horizontal construction joints in the pedestal should be located at approximately equal spaces. The surface of concrete construction joints should be cleaned, and laitance removed.

4.1.2.9.2 Expansion joints—Slabs-on-ground and intermediate floor slabs not structurally connected to the pedestal wall should be isolated from the pedestal wall by premolded expansion joint filler.

4.1.2.9.3 Contraction joints—Contraction joints are only used with slabs-on-ground (**Section 7.8.2.3**).

4.1.2.9.4 Embedments—Sleeves, inserts, and embedded items should be installed before concrete placement, and should be accurately positioned and secured against displacement. Post-installed anchors should be installed per ACI 318-05, Appendix D.

4.1.3 Formwork

4.1.3.1 General—Formwork design, installation, and removal should conform to the requirements of ACI 318 and the recommendations of ACI 347. Formwork should ensure that concrete components of the structure will conform to the correct dimensions, shape, alignments, elevation, and position within the established tolerances. Formwork systems should be designed to safely support construction and expected environmental loads, and should be provided with ties and bracing as required to prevent the leakage of mortar and excessive deflection.

4.1.3.1.1 Facing material—Facing material of forms used above finished grade should be metal, or plywood faced with plastic or coated with fiberglass.

4.1.3.1.2 Chamfers—Exposed corners should be formed with chamfers 3/4 in. (20 mm) or larger.

4.1.3.1.3 Concrete strength—The minimum concrete compressive strength required for safe removal of any supports for shored construction, or the safe use of construction embedments or attachments should be shown on construction drawings and written instructions used by field personnel.

4.1.3.1.4 Cleaning and coating—Form surfaces should be cleaned of foreign materials and coated with a nonstaining release agent before reinforcement is placed.

4.1.3.1.5 Inspection—Before placing concrete, forms should be inspected for surface condition, accuracy of alignment, grade and compliance with tolerance, reinforcing steel

clearances, and location of embedments. Shoring and bracing should be checked for conformance to design.

4.1.3.2 Foundations

4.1.3.2.1 Side forms—Straight form panels that circumscribe the design radius may be used to form circular foundation shapes. Circular surfaces below final ground level may have straight segments that do not exceed 30 degrees of arc, and surfaces exposed to view may have straight segments that do not exceed 15 degrees of arc.

4.1.3.2.2 Top forms—Forms should be provided on top sloping surfaces steeper than 1 vertical to 2.5 horizontal, unless it can be demonstrated that the shape can be adequately maintained during concrete placement and consolidation.

4.1.3.2.3 Removal—Top forms on sloping surfaces may be removed when the concrete has attained sufficient strength to prevent plastic movement or deflection. Side forms may be removed when the concrete has attained sufficient strength such that it will not be damaged by removal operations or subsequent load.

4.1.3.3 Pedestal

4.1.3.3.1 Wall form—The pedestal should be constructed using a form system having curved, prefabricated form segments of the largest practical size to minimize form panel joints. Formwork should be designed for lateral pressures associated with full height fresh concrete head. Bracing should be provided for stability, construction-related impact loading, and wind loads. Working platforms that allow access for inspection and concrete placement should be provided.

4.1.3.3.2 Deflection—Deflection of facing material between studs as well as studs and walers should not exceed 1/400 times the span during concrete placement.

4.1.3.3.3 Rustications—A uniform pattern of vertical and horizontal rustications to provide architectural relief may be used for exterior wall surfaces exposed to view. Construction joints should be located in rustications.

4.1.3.3.4 Form ties—Metal form ties that remain within the wall should be set back no less than 1-1/2 in. (40 mm) from the concrete surface.

4.1.3.3.5 Removal—Vertical formwork not supporting the weight of the component may be removed when the concrete has reached sufficient strength such that it will not be damaged by the removal operation and subsequent loads.

4.1.4 Reinforcement

4.1.4.1 General—Reinforcement should be clearly indicated on construction drawings. Location, spacing, reinforcement lap splice lengths, and concrete cover should be shown. Symbols and notations should be provided to indicate or clarify placement requirements.

4.1.4.2 Fabrication—The details of fabrication, including hooks and minimum diameter of bends, should conform to the requirements of ACI 318 and 315.

4.1.4.3 Placement—Reinforcement should be accurately positioned, supported, and securely tied to prevent displacement of the steel during concrete placement. Bar spacing limits and surface condition of reinforcement should conform to the requirements of ACI 318.

4.1.4.3.1 Concrete cover—The following minimum concrete cover should be provided for reinforcement in cast-in-place concrete. Cover is measured at the thinnest part of the wall, at the bottom of rustication grooves, or between the raised surfaces of architectural feature panels.

Concrete foundations permanently exposed to earth	Minimum cover, in. (mm)
Cast against earth	3 (75)
Cast against forms or mud slabs, or top reinforcement: No. 6 (19) bar, and larger	2 (50)
No. 5 (16) bar, W31 (MW200) or D31 (MD200) wire, and smaller	1-1/2 (40)
Pedestal	
Exterior surfaces: No. 6 (19) bar, and larger	2 (50)
No. 5 (16) bar, W31 (MW200) or D31 (MD200) wire, and smaller	1-1/2 (40)
Interior surfaces: All bars, wire larger than W11 (MW70) or D11 (MD70)	1-1/2 (40)
Wire smaller than W11 (MW70) or D11 (MD70)	1 (25)
Sections designed as beams or columns	1-1/2 (40)

4.1.4.3.2 Supports for reinforcement should conform to the following:

(a) The number of supports should be sufficient to prevent out-of-tolerance deflection of reinforcement in accordance with ACI 117, and to prevent overloading any individual support;

(b) Shallow foundation reinforcement placed adjacent to the ground or working slab should be supported by precast concrete masonry units or metal or plastic bar supports;

(c) Reinforcement adjacent to formwork should be supported by metal or plastic bar supports. The portions of bar supports within 1 in. (25 mm) of the concrete surface should be noncorrosive or protected against corrosion; and

(d) Pedestal reinforcement should be supported by metal or plastic bar supports. Maximum spacing of supports for welded wire reinforcement should be on 4 ft (1.2 m) centers, horizontally and vertically.

4.1.4.4 Development of splices

4.1.4.4.1 Development and splice lengths—Development and splices of reinforcement should be in accordance with ACI 318. The location and details of reinforcement development and lap splices should be shown on construction drawings.

4.1.4.4.2 Welding—Welding of reinforcement should conform to AWS D1.4. Welding should only be performed by certified welders in accordance with Weld Procedure Specifications specific to the reinforcement being welded. A full welded splice should develop 125% of the specified yield strength of the bar. Reinforcement should not be tack welded.

4.1.4.4.3 Mechanical connections—The type, size, and location of any mechanical connections should be shown on construction drawings. A full mechanical connection should develop in tension or compression, as required, 125% of the specified yield strength of the bar. Tests to confirm the minimum 125% may be required.

4.1.5 Concrete finishes

4.1.5.1 Surface repair

4.1.5.1.1 Patching materials—Concrete should be patched with a proprietary patching material or site-mixed

portland cement mortar. Patching material for exterior surfaces should match the surrounding concrete in color and texture.

4.1.5.1.2 Repair of defects—Concrete should be repaired as soon as practicable after form removal. Honeycomb and other defective concrete should be removed to sound concrete and patched.

4.1.5.1.3 Tie holes—Tie holes should be patched, except that manufactured plastic plugs may be used for exterior surfaces.

4.1.5.2 Formed surfaces—Finishing of formed surfaces should conform to the following:

(a) Exterior exposed surfaces of the pedestal and foundations should have a smooth as-cast finish, unless a special form finish is specified;

(b) Interior exposed surfaces of the pedestal should have a rough as-cast finish unless otherwise specified; and

(c) Concrete not exposed to view may have a rough as-cast finish.

4.1.5.2.1 Rough as-cast finish—Any form-facing material can be used, provided the forms are substantial and sufficiently tight to prevent mortar leakage. The surface is left with the texture imprinted by the form. Defects and tie holes should be patched, and fins exceeding 1/4 in. (6 mm) in height should be removed.

4.1.5.2.2 Smooth as-cast finish—Form facing material and construction should conform to Section 4.1.3. The surface is left with the texture imprinted by the form. Defects and tie holes should be patched and fins should be removed by chipping or rubbing.

4.1.5.2.3 Special form finish—A smooth as-cast finish is produced, after which additional finishing is performed. The type of additional finishing required should be specified.

4.1.5.3 Trowel finishes—Unformed concrete surfaces should be finished in accordance with the following:

Slabs-on-ground and intermediate floor slabs	Steel trowel
Concrete tank vessel dome, vessel floor and platform	Floated
Composite steel-concrete tank dome	
and flat slab tank floors.....	Floated
Foundations.....	Floated
Surfaces receiving grout	Floated

4.1.6 Tolerances

4.1.6.1 Concrete tolerances—Tolerances for concrete should conform to ACI 117 and the following recommendations:

Dimensional tolerances for the pedestal:	
Variation in wall thickness:	−3%, +5.0%
Variation from plumb: in any 5 ft (1.6 m) of height (1/160)	3/8 in. (10 mm)
in any 50 ft (16 m) of height (1/400) maximum in total height	1-1/2 in. (40 mm) 3 in. (75 mm)
Diameter variation not to exceed	0.4% 3 in. (75 mm)
Level alignment variation: from specified elevation from horizontal plane	1 in. (25 mm) 1/2 in. (13 mm)
The offset between adjacent pieces of formwork facing material should not exceed the following:	
Exterior exposed surfaces	1/8 in. (3 mm)
Interior exposed surfaces	1/4 in. (6 mm)
Unexposed surfaces	1/2 in. (13 mm)

4.1.6.2 Out-of-tolerance construction—The effect on the structural capacity of the element should be determined by the responsible design professional if construction does not conform to **Section 4.1.6.1**. When structural capacity is not compromised, repair or replacement of the element is not required unless other governing factors, such as lack of fit and aesthetics, require remedial action.

4.1.7 Foundations

4.1.7.1 Reinforced concrete—Concrete, formwork, and reinforcement should follow the applicable recommendations of **Sections 4.1.2, 4.1.3, and 4.1.4**, respectively.

4.1.7.2 Earthwork

4.1.7.2.1 Excavations—Foundation excavations should be dry and have stable side slopes. Applicable safety standards and regulations should be followed in constructing excavations.

4.1.7.2.2 Inspection—Excavations should be inspected by a licensed geotechnical engineer before concrete construction to ensure that the material encountered reflects the findings of the geotechnical report.

4.1.7.2.3 Mud mats—A lean concrete mud mat is recommended to protect the bearing stratum and to provide a working surface for placing reinforcement.

4.1.7.2.4 Backfill—Backfill should be placed and compacted in the specified uniform horizontal lifts. Fill inside the pedestal should conform to **Section 7.8.2.5**. The suitability of in-place and fill soils outside the pedestal for supporting paving subject to traffic should be determined by the geotechnical design professional. Fill material outside the pedestal may be unclassified soils free of organic matter and debris. Compaction of backfill material should comply with **Table 4.1**.

4.1.7.2.5 Grading—Site grading around the tank should provide positive drainage away from the tank to prevent ponding of water in the foundation area.

4.1.7.3 Field inspection of deep foundations—Field inspection, under the direction of a licensed professional engineer, of foundations and concrete work should conform to the following:

- (a) Continuous inspection during pile driving and placement of concrete in deep foundations; and
- (b) Periodic inspection during construction of drilled piers or piles, placement of reinforcement, and placement of concrete.

4.1.8 Pedestal

4.1.8.1 General—The tank pedestal should be a reinforced concrete cylindrical shell structure and should be constructed using an approved jump, slip, or conventional formwork.

4.1.8.2 Reinforced concrete—Concrete, formwork, and reinforcement should follow the applicable recommendations of **Sections 4.1.2, 4.1.3, and 4.1.4**, respectively.

4.1.8.3 Inspection—Concrete formwork and steel reinforcement should be inspected by an ACI certified Concrete Construction Special Inspector or an inspector with equivalent qualifications before concrete placement to ensure that the tolerances of construction are satisfied.

4.2—Construction specific to composite tanks

4.2.1 Formwork for tank floor

4.2.1.1 Design—Formwork for the flat slab or dome tank floor for the steel vessel should be designed to support

Table 4.1—Minimum compaction requirements for backfill

Description	Standard Proctor* compaction—ASTM D698 (2.4 m)	Modified Proctor* compaction—ASTM D1557 (2.4 m)
Pedestal interior: slabs-on-ground† -door opening width <8 ft (2.4 m) -door opening width >8ft (2.4 m)	— —	90% 95%
Pedestal exterior* -paved areas subject to traffic -sidewalks -landscaped or unpaved areas	— 95% 90%	95% — —

*The larger compaction energy of modified Proctor testing is considered appropriate for paved areas subject to traffic loading. Standard Proctor density is considered appropriate for pedestal exterior backfill under sidewalks and exterior unpaved areas where minimizing potential settlement is a consideration.

†Pedestal door opening width is used to distinguish between light-duty and heavy-duty floor loads. Floors inside pedestals with door openings 8 ft (2.4 m) or less in width are considered subject to light-duty vehicle loading, such as pickup trucks. HS20 truck wheel loads should be considered where pedestal door opening width exceeds 8 ft (2.4 m).

construction loads including weight of forms, fresh concrete, personnel, equipment, temporary storage, and impact forces. Unsymmetrical placement of concrete should be considered in the design. Camber to offset concrete weight should be provided where deflection would result in out-of-tolerance construction.

4.2.1.2 Removal—Forms should remain in place until the concrete has gained sufficient strength, as defined by the engineer in compliance with ACI 350, Section 6.2, not to be damaged by removal operations and subsequent loads. The minimum required concrete strength for form removal should be shown on construction drawings or instructions issued to the field.

4.2.2 Grout for steel liner—Unformed steel liner plates that do not match the shape of the concrete floor may be used provided the liner plate is grouted after welding. The steel liner should be constructed with a 1 in. (25 mm) or larger grout space between the liner plate and the concrete member. The space should be completely filled with a flowable grout using a procedure that removes entrapped air. Anchorage should be provided in areas where the grout pressure is sufficient to lift the plate.

4.2.3 Steel tank vessel—Fabrication and erection of steel tank vessels should comply with the standards specified for design and construction in **Section 5.3.3**.

4.2.4 Concrete cover—Tank floors covered by steel liners and intermediate floors should have concrete reinforcement cover of 1-1/2 in. (40 mm).

4.2.5 Concrete tolerances—Tolerances for concrete and reinforcement should conform to ACI 117 and the following for steel vessel tank floor concrete:

- Dome tank floor radius variation 1.0%
- Dome tank floor thickness variation -6.0%, +10.0%
- Dome tank floor level alignment variation:

- From specified elevation 1 in. (25 mm)
- From horizontal plane 1/2 in. (13 mm)

The finish tolerance of troweled surfaces should not exceed the following when measured with a 10 ft (3 m) straightedge or sweep board:

- Exposed floor slab 3/8 in. (6 mm)
- Tank floors 3/4 in. (20 mm)

4.3—Construction specific to concrete tanks

4.3.1 Formwork

4.3.1.1 Tank floor

4.3.1.1.1 Design—Formwork for the transition section for the concrete vessel should be designed to support construction loads including weight of forms, fresh concrete, personnel, equipment, temporary storage, and impact forces. Unsymmetrical placement of concrete should be considered in the design. Camber to offset concrete weight should be provided where deflection would result in out-of-tolerance construction.

4.3.1.1.2 Removal—Forms should remain in place until the concrete has gained sufficient strength, as defined by the engineer in compliance with ACI 350, Section 6.2, not to be damaged by removal operations and subsequent loads. The minimum required concrete strength for form removal should be shown on construction drawings or instructions issued to the field.

4.3.1.2 Tank vessel cone and cylindrical wall

4.3.1.2.1 Wall form—Inside and outside formwork for casting of the concrete vessel cone and cylindrical wall elements should be designed to be self-supporting. The formwork should be designed to minimize the number of construction joints. The formwork system should be configured in such a way that the maximum concrete drop will be 4 ft (1.2 m) at any point during casting. To accommodate the aforementioned requirement, the formwork should use a shutter board panel system, which allows visual inspection of all surfaces where panels are placed immediately before casting concrete. Facing material of forms used for the concrete tank vessel cone and cylindrical wall should be high quality, 1 in. (25 mm) minimum thick, plywood shutter boards.

4.3.1.2.2 Deflection—Deflection of facing material between studs as well as studs and walers should not exceed 1/400 times the span during concrete placement.

4.3.1.2.3 Form ties—No form ties should be used within water-retaining elements.

4.3.1.2.4 Removal—Vertical formwork not supporting the weight of the component may be removed when the concrete has reached sufficient strength, as defined by the engineer in compliance with ACI 350, Section 6.2, such that it will not be damaged by the removal operation and subsequent loads.

4.3.1.3 Tank vessel access shaft

4.3.1.3.1 Wall form—Inside and outside formwork for casting of the concrete tank vessel access shaft should be designed to be self-supporting. The formwork should be designed to minimize the number of construction joints. The formwork system should be configured in such a way that the maximum concrete drop will be 8 ft (2.4 m) at any point during casting. Any form material may be used for the vessel access shaft.

4.3.1.3.2 Deflection—Deflection of facing material between studs as well as studs and walers should not exceed 1/360 times the span during concrete placement.

4.3.1.3.3 Form ties—No form ties should be used in the tank vessel access shaft.

4.3.1.3.4 Removal—Vertical formwork not supporting the weight of the component can be removed when the concrete has reached sufficient strength, as defined by the engineer in compliance with ACI 350, Section 6.2, such that it will not be damaged by the removal operation and subsequent loads.

4.3.2 Prestressed reinforcement

4.3.2.1 General—Post-tensioned tendons should be clearly indicated on construction drawings. Location, spacing, and concrete cover should be shown. Symbols and notations should be provided to indicate or clarify placement requirements.

4.3.2.2 Fabrication—The details of fabrication should conform to the requirements of ACI 350.

4.3.2.3 Placement—Tendons should be accurately positioned, securely tied, and supported to prevent displacement of the steel during concrete placement in accordance with ACI 117.

4.3.2.3.1 Concrete cover—The minimum concrete cover over post-tensioning ducts or sheathing should be 2 in. (50 mm).

4.3.2.3.2 Supports—The number of supports should be sufficient to prevent out-of-tolerance deflection of post-tensioning tendons and to prevent overloading any individual support.

4.3.3 Concrete tank vessel

4.3.3.1 General—The concrete tank vessel consists of the following elements:

- (a) Transition that joins the pedestal, vessel cone, and vessel access shaft;
- (b) Vessel cone that forms the majority of the exterior water-containment structure;
- (c) Vessel cylindrical wall that completes the water-containment structure and acts as the support ring for the dome;
- (d) Free-span dome, that is, having no interior supports, that acts as the roof of the tank vessel;
- (e) Vessel access shaft that provides access to the vessel dome and interior platform, if provided; and
- (f) Vessel platform, if provided, that provides access to the interior of the vessel and a ladder to the dome.

The vessel cone and vessel cylindrical wall are post-tensioned concrete. The remaining elements of the tank vessel are nonprestressed concrete.

4.3.3.2 Reinforced concrete—Concrete, formwork, and reinforcement should follow the applicable recommendations of [Sections 4.1.2](#), [4.1.3](#), and [4.1.4](#) respectively.

4.3.3.2.1 Concrete cover—Tank vessel elements, both prestressed and nonprestressed, should have covers in accordance with ACI 350.

4.3.3.3 Inspection—Concrete formwork, steel reinforcement, and post-tensioning ducts and tendons should be inspected by an ACI certified Concrete Construction Special Inspector or an inspector with equivalent qualifications before concrete placement to ensure that the tolerances of construction are satisfied.

4.3.3.4 Concrete tolerances—Tolerances for concrete and reinforcement should conform to ACI 117 and the following:

Dimensional tolerances for concrete tank vessel cone, cylindrical wall, and access shaft:	
Variation in wall thickness: Variation from meridian plumb: in any 5 ft (1.6 m) of height (1/160) in any 50 ft (16 m) of height (1/400) maximum in total height	−3%, +5.0% 3/8 in. (10 mm) 1-1/2 in. (40 mm) 3 in. (75 mm)
Diameter variation: not to exceed Thickness tolerance:	0.4% 3 in. (75 mm) −5%, +5%
Flatness limit for the concrete tank dome should be in conformance to ACI 373R-97, Section 4.6.6.	

4.3.4 Construction joints—Location of construction joints and their details should be shown on construction drawings. Horizontal construction joints in the vessel cone and access shaft should be approximately evenly spaced. All construction joints in components exposed to stored water should have a positive waterstop.

CHAPTER 5—DESIGN

5.1—Design recommendations common to both composite and concrete tank types

5.1.1 Scope—This chapter recommends design and analysis procedures of elevated concrete and composite steel-concrete storage water tanks.

5.1.1.1 Design recommendations for foundation—The foundation should be designed to provide sufficient strength to support the tank vessel and pedestal. The foundation and its connection to the pedestal should be designed to resist the axial loads, shears, and moments determined from an analysis of the loadings in Section 5.1.2.2. In areas of high seismicity, the foundation should provide capacity to resist the seismic forces defined in Section 5.1.2.8 against sliding and overturning, and details in Section 5.2.1.6 that promote ductility and energy dissipation. The methods of allowable stress design may be used to determine the stresses at the foundation/earth interface due to bearing, sliding, and overturning.

5.1.1.2 Design recommendations for pedestal—The pedestal should be designed to provide sufficient strength to support the tank vessel. The pedestal and its connection to the tank vessel should be designed to resist the axial forces, shears, and moments determined from an analysis of the loadings in Section 5.1.2.2. In areas of high seismicity, the pedestal should provide capacity to resist the seismic forces defined in Section 5.1.2.8, and details in Section 5.2.2.2 that promote ductility and energy dissipation. The design of the pedestal should conform to ACI 318, except as modified herein. The pedestal design should also accommodate access to the tank vessel.

5.1.1.3 Design recommendations for tank vessel—The tank vessel should be designed to provide watertight containment of water within the vessel as well as protection of the contained water from environmental contamination from without. The tank vessel should be designed to resist the axial forces, shears, and moments determined from analysis based on loading combinations in Section 5.1.2.2.

5.1.1.4 Design recommendations for other elements

5.1.1.4.1 Concrete members—Design of concrete members such as floor slabs and similar structural members should conform to ACI 318 and the recommendations of Section 7.8.

5.1.1.4.2 Nonconcrete members—Design of non-concrete-related elements, such as appurtenances, accessories, and structural steel framing members, should conform to recognized national standards for the type of construction.

5.1.1.4.3 Industrial safety-related components—Handrails, ladders, platforms, and similar safety-related components should conform to the applicable building code, and to Occupational Safety and Health Administration (OSHA) standards.

5.1.2 Loads

5.1.2.1 General—The elevated water storage tank, and its elements and connections, should be designed for load combinations in Section 5.1.2.2 or by the applicable building code.

5.1.2.2 Load combinations

5.1.2.2.1 Factored load combinations—Load factors and load combinations for the Strength Design Method should conform to Section 5.1.2.2.1.1 or 5.1.2.2.1.2. The load terms are as defined in Section 2.1.

5.1.2.2.1.1 Factored load combinations for structural components not in contact with stored water

5.1.2.2.1.1.1 Group 1 load combinations—where structural effects of applied loads are cumulative

Load Combination

$$U1.1 \quad U = 1.4(D + F)$$

$$U1.2 \quad U = 1.2(D + F + G) + 1.6L + 0.5S + 1.2T$$

$$U1.3 \quad U = 1.2(D + F + G) + 1.3W + 0.5L + 0.5S + 1.2T$$

$$U1.4 \quad U = 1.2(D + F + G) + 1.6S + 0.5L + 1.2T$$

$$U1.5 \quad U = 1.2(D + F + G) + 1.0E + 0.5L + 0.2S + 1.2T$$

5.1.2.2.1.1.2 Group 2 load combinations—where D or F reduce the effect of W or E

Load Combination

$$U2.1 \quad U = 0.9D + 1.0F + 1.0E$$

$$U2.2 \quad U = 0.9D + 1.0E$$

$$U2.3 \quad U = 0.9D + 1.3W$$

Load Combination U2.1 does not conform to ACI 318 because the entire weight of the acting fluid participates in the development of the seismic load. Unlike the dead load, which is not precisely known, the fluid weight is well defined.

5.1.2.2.1.2 Factored load combinations for structure components in contact with stored water—Load combinations for structure components in contact with stored water should conform to ACI 350.

5.1.2.2.2 Nominal load combinations—Nominal service load combinations should conform to Section 5.1.2.2.2.1 or 5.1.2.2.2.2. The load terms are as defined in Section 2.1.

5.1.2.2.2.1 Nominal load combinations for structure components not in contact with stored water

5.1.2.2.2.1.1 Group 1 load combinations—where structural effects of applied loads are cumulative

Load Combination

$$S1.1 \quad D + F$$

$$S1.2 \quad D + F + G + S + L + T$$

$$S1.3 \quad D + G + W + L + S$$

$$S1.4 \quad D + F + G + 0.7E + L + S$$

5.1.2.2.2.1.2 Group 2 load combinations—where

D or F reduce effect of W or E

Load Combination

- S2.1 0.6D + W
- S2.2 0.6D + 0.7E
- S2.3 0.6(D + F) + 0.7E

5.1.2.2.2.2 Nominal load combinations for structure components in contact with stored water—Load combinations for structure components in contact with stored water should conform to ACI 350.

5.1.2.3 Dead loads—The dead loads include the weight of structure elements, access ladders and platforms, and all structure-supported appurtenances. The unit weight of materials used to determine dead loads should be as follows:
 Reinforced concrete 150 lb/ft³ (2400 kg/m³)
 Steel..... 490 lb/ft³ (7850 kg/m³)
 Aluminum 165 lb/ft³ (2650 kg/m³)

5.1.2.4 Water load—The water load is the weight of the water in the tank vessel, at levels varying from empty to the overflow level, calculated at 62.4 lb/ft³ (1000 kg/m³), and the lateral pressure on the walls of the container.

5.1.2.4.1 Equivalent weights of accelerated water—For use in seismic analyses in Sections 5.1.2.8.2.1 and 5.1.2.8.2.2, the equivalent weights of the convective (sloshing) component and the impulsive component of the water in circular cylindrical elevated tank vessels should be computed in accordance with ACI 350.3-06, Chapter 9.

For geometries of tank vessels other than circular cylindrical, fluid-structure interaction analysis of the stored water maybe conducted to determine the equivalent weights of the impulsive and convective components of the stored water, or the fluid-structure interaction analysis may be integrated with the modal analysis of Section 5.1.2.8.2.2.

A close approximation for impulsive and convective masses of axisymmetric, other than cylindrical, tanks may be

obtained from an equivalent cylindrical tank that has the same free surface diameter as the axisymmetric tank and a depth that results in the same volume as the axisymmetric tank.

5.1.2.5 Live loads—Live loads include a uniformly distributed load specified in the local building code with a minimum of an industry standard 12 lb/ft² (0.58 kPa) over the horizontal projected area of the tank vessel roof extending to the eave line, and the live loads on the access stairs and platforms of 60 lb/ft² (2.87 kPa). Where equipment is supported on platforms, an additional live load of 40 lb/ft² (1.92 kPa) should be included. A concentrated load of 1000 lb (4.45 kN), not in combination with the distributed live load, should be included on stairs and platforms.

5.1.2.6 Wind load

5.1.2.6.1 Scope—This section covers determination of minimum wind forces, based on ASCE/SEI 7 for Category IV structures with Exposure Categories C and D, for use in load combinations in Section 5.1.2.2. Larger wind loads should be used where required by the applicable building code.

5.1.2.6.2 Wind force—The wind force *W* acting on the structure is the sum of wind forces *F_z* acting on any portion of the structure defined by

$$F_z = p_z A_f \tag{5-1}$$

where *A_f* = vertical projected area of the portion of the structure considered; and *p_z* = lateral wind pressure acting on projected area *A_f* at height *z*.

Lateral pressure *p_z* at height *z* above grade is given in Table 5.1.

5.1.2.6.3 Wind pressure distribution—ASCE/SEI 7-05 Fig. 6-7 may be used to define wind pressure distribution on spherical dome roofs of elevated tanks. Other pressure distributions may be used if adequately verified, such as by wind tunnel test studies.

Table 5.1—Design wind pressure *p_z* (lb/ft²) (kPa) for *V_b* = 90 mph (40 m/s) *†‡

Height zone, ft (m)	<i>C_f</i> = 0.50		<i>C_f</i> = 0.55		<i>C_f</i> = 0.60	
	Exposure C, lb/ft ² (kPa)	Exposure D, lb/ft ² (kPa)	Exposure C, lb/ft ² (kPa)	Exposure D, lb/ft ² (kPa)	Exposure C, lb/ft ² (kPa)	Exposure D, lb/ft ² (kPa)
0 to 25 (0 to 7.6)	12.0 (0.575)	13.4 (0.642)	12.4 (0.594)	14.8 (0.709)	13.5 (0.647)	16.1 (0.771)
25 to 50 (7.6 to 15.2)	13.0 (0.623)	15.1 (0.723)	14.4 (0.690)	16.7 (0.800)	15.7 (0.752)	18.2 (0.872)
50 to 75 (15.2 to 22.9)	14.2 (0.680)	16.3 (0.781)	15.6 (0.747)	17.9 (0.857)	17.0 (0.814)	19.5 (0.934)
75 to 100 (22.9 to 30.5)	15.1 (0.723)	17.1 (0.819)	16.6 (0.795)	18.8 (0.900)	18.1 (0.867)	20.5 (0.982)
100 to 125 (30.5 to 38.1)	15.8 (0.757)	17.8 (0.852)	17.4 (0.833)	19.5 (0.934)	19.0 (0.910)	21.3 (1.020)
125 to 150 (38.1 to 45.7)	16.4 (0.785)	18.3 (0.876)	18.1 (0.867)	20.2 (0.967)	19.7 (0.943)	22.0 (1.054)
150 to 175 (45.7 to 53.4)	17.0 (0.814)	18.8 (0.900)	18.7 (0.896)	20.7 (0.991)	20.4 (0.977)	22.6 (1.082)
175 to 200 (53.4 to 61.0)	17.5 (0.838)	19.3 (0.924)	19.2 (0.920)	21.2 (1.015)	21.0 (1.006)	23.1 (1.106)
200 to 225 (61.0 to 68.6)	17.9 (0.857)	19.7 (0.943)	19.7 (0.943)	21.6 (1.034)	21.5 (1.030)	23.6 (1.130)
225 to 250 (68.6 to 76.2)	18.3 (0.876)	20.0 (0.958)	20.1 (0.963)	22.0 (1.054)	22.0 (1.054)	24.0 (1.149)
250 to 275 (76.2 to 83.8)	18.7 (0.896)	20.4 (0.977)	20.5 (0.982)	22.4 (1.073)	22.4 (1.073)	24.5 (1.173)
275 to 300 (83.8 to 91.5)	19.0 (0.910)	20.7 (0.991)	20.9 (1.001)	22.8 (1.092)	22.8 (1.092)	24.8 (1.188)

*Tabulated for gust factor *G_w* = 1.0. Where structure period *T* is less than 1.0 second, tabulated values may be multiplied by 0.85.

†For basic wind speeds greater than 90 mph (40 m/s), the design wind pressure *p_z* can be determined by multiplying tabulated values by *V_b*²/8100 (*V_b*²/1600).

‡*C_f* = 0.5 + (*h/d_w* - 1)/60 0.5 ≤ *C_f* ≤ 0.6

where *h/d_w* is the height-diameter ratio. Height *h* should not be less than height from grade to the top of vessel shell. Diameter should be taken as the maximum vessel diameter or, more precisely, as weighted average of the vessel and shaft diameters with height.

5.1.2.7 Snow load

5.1.2.7.1 General

5.1.2.7.1.1 Scope—This section covers determination of snow load, based on ASCE/SEI 7 for Category IV unheated structures, for use in load combinations in [Section 5.1.2.2](#). Larger snow loads should be used where required by the applicable building code.

5.1.2.7.1.2 Limitations—The provisions of Section 5.1.2.7 are applicable to cone, conical, and curved roofs concave downward without steps or abrupt changes in elevation.

5.1.2.7.2 Roof snow load—The unfactored balanced snow load acting on the structure is the uniformly distributed snow load p_s acting on any portion of a roof times the horizontal projected area on which p_s acts. The uniformly distributed snow load p_s is the larger value determined in Sections 5.1.2.7.2.1 and 5.1.2.7.2.2.

5.1.2.7.2.1 Balanced roof snow load—The balanced snow load on roofs with a roof slope less than or equal to 45 degrees should be calculated from

$$p_s = C_{es}p_g \quad (5-2a)$$

where p_g = ground snow load, ASCE/SEI 7-05 Fig. 7-1 or [Table 7.1](#); and C_{es} = exposure factor, ASCE/SEI 7-05 Table 7.2 and the exposure category from ASCE/SEI 7-05, Section 6.5.6.3.

The balanced snow load on roofs with a roof slope greater than 45 degrees, but not exceeding 70 degrees, should be calculated from

$$p_s = C_{es}p_g(70 - \theta_r)/25 \quad (5-2b)$$

Roofs with $\theta_r > 70$ degrees should be considered snow free.

5.1.2.7.2.2 Minimum snow load—The minimum snow load acting on cone roofs with roof slope θ_r less than 15 degrees and curved and conical roofs with roof slope θ_r less than 10 degrees should be calculated from Eq. (5-2c) or (5-2d)

$$p_s = 1.2p_g \text{ for } p_g \leq 20 \text{ lb/ft}^2 \text{ (0.96 kPa)} \quad (5-2c)$$

$$p_s = 24(1.15 \text{ kPa}) \text{ for } p_g > 20 \text{ lb/ft}^2 \text{ (0.96 kPa)} \quad (5-2d)$$

5.1.2.7.2.3 Rain-on-snow surcharge—At locations where $p_g \leq 20 \text{ lb/ft}^2$ (0.96 kPa), the rain-on-snow surcharge p_r is 5 lb/ft^2 (0.24 kPa) for roof slopes less than $W_r/50$ (in degrees), where W_r is the horizontal distance in ft from eaves to center of cone, conical, or curved roofs.

5.1.2.8 Earthquake load—Earthquake load should be in accordance with ASCE/SEI 7-05 Chapters 11, 14, 15, 19, 20, and 22.

5.1.2.8.1 Procedure for determining design earthquake ground acceleration and response spectra

1. The site should be classified in accordance with site class definitions of ASCE/SEI 7-05, Section 11.4.2;

2. The maximum considered earthquake spectral response acceleration at short periods, S_s , and at 1 second, S_1 , should be determined from ASCE/SEI 7-05, Fig. 22-1 through Fig. 22-14;

3. The acceleration-based site coefficient F_a and the velocity-based site coefficient F_v should be determined from ASCE/SEI 7-05, Table 11.4-1 and Table 11.4-2, respectively;

4. The design spectral response accelerations for short periods, S_{DS} , and for 1-second period, S_{D1} , should be calculated from

$$S_{DS} = (2/3)F_aS_s \quad (5-3a)$$

$$S_{D1} = (2/3)F_vS_1 \quad (5-3b)$$

5. The design response spectrum for lateral acceleration should be constructed in accordance with ASCE/SEI 7-05, Section 11.4.5; and

6. For the vertical acceleration design spectrum, 2/3 of the design spectrum for lateral loads should be used. Refer to Section 5.1.2.8.2 for combining effects due to lateral and vertical accelerations.

5.1.2.8.2 Structural analysis procedures—The seismic base shear, seismic overturning moment at the base, and the seismic shear and overturning moment induced at any level in the elevated tank above its base may be computed using the equivalent lateral force procedure in accordance with Section 5.1.2.8.2.1 or the modal analysis procedure in accordance with [Section 5.1.2.8.2.2](#). ASCE/SEI 7-05 Chapter 19 permits the reduction due to soil-structure interaction.

The modal analysis procedure may also be used to compute the response of the elevated tank to vertical seismic accelerations. The combined vertical and lateral seismic response effects in Load Combinations U1.5, U2.1, and U2.2 in [Section 5.1.2.2.1](#) and Load Combinations S1.4, S2.2, and S2.3 in [Section 5.1.2.2.2](#) should be as follows:

(a) $E = 1.0 \times$ (response to lateral acceleration) $+ 0.3 \times$ (response to vertical acceleration); and

(b) $E = 0.3 \times$ (response to lateral acceleration) $+ 1.0 \times$ (response to vertical acceleration).

The first combination of lateral and vertical seismic acceleration effects can be expected to result in maximum base shear and overturning moment, and maximum shear in the mid-surface of the wall of all elevated tank components. The second combination can be expected to result in maximum hoop stress in the tank vessel, compression in domed floors, and bending in flat slab floors of composite steel-concrete tanks. The meridional compression stress in the tank vessel, the meridional compression stress in the transition of concrete tanks, and the vertical stress in the pedestal should be evaluated with both combinations.

5.1.2.8.2.1 Equivalent lateral force procedure

5.1.2.8.2.1.1 Base level—Base is the level at which horizontal ground motions are considered to be imparted to the structure. Base level is bottom of foundation, except it may be considered to be midheight of the pile cap where piles are rigidly connected to the pile cap.

5.1.2.8.2.1.2 Seismic base shear—The seismic base shear V in a given direction should be determined from

$$V = C_sW_e \quad (5-4)$$

where C_s = seismic response coefficient in accordance with Section 5.1.2.8.2.1.3; and W_e = effective weight in accordance with Section 5.1.2.8.2.1.4.

5.1.2.8.2.1.3 Seismic response coefficient—The seismic response coefficient should be computed from

$$C_s = S_{DS}I/R \quad (5-5a)$$

Alternatively, the seismic response coefficient C_s need not be greater than

$$C_s = S_{DI}/T_f R \quad (5-5b)$$

but should not be taken less than

$$C_s = 0.044S_{DS}I \quad (5-5c)$$

where T_f = fundamental period of the structure determined in Section 5.1.2.8.2.1.5, and R and I are in accordance with ASCE/SEI 7 or as required by the applicable building code.

5.1.2.8.2.1.4 Effective weight—The effective weight W_e should include the total dead weight of the elevated tank in accordance with Section 5.1.2.3, the effective weight of the water in accordance with Section 5.1.2.4.1, 25% of live load, and 20% of roof snow load where flat roof snow load exceeds 30 lb/ft² (1.4 kPa).

5.1.2.8.2.1.5 Period determination—The fundamental period T should be established using the effective weight in Section 5.1.2.8.2.1.4 and stiffness characteristics of the resisting elements in a properly substantiated analysis.

5.1.2.8.2.1.6 Vertical distribution of seismic forces—The lateral seismic force F_x induced at any level should be determined from

$$F_x = C_{vx}V \quad (5-6a)$$

and

$$C_{vx} = \frac{W_x h_x^k}{\sum_{i=1}^n W_i h_i^k} \quad (5-6b)$$

where C_{vx} = vertical distribution factor; V = total design lateral force or shear at the base of the structure from Eq. (5-4); W_i and W_x = portion of the total effective load of the structure W_e located or assigned to level i or x ; h_i and h_x = height from the base to level i or x ; and k = exponent related to the structure period as follows: for structures having a period of 0.5 seconds or less, $k = 1$; for structures having a period of 2.5 seconds or more, $k = 2$; and for structures having a period between 0.5 and 2.5 seconds, k should be 2 or should be determined by linear interpolation between 1 and 2.

When the dead load is less than 25% of the total load, the total lateral seismic force can be distributed over the height of the structure in proportion to the structure weight. The vertical distribution factor is then

$$C_{vx} = \frac{W_x}{\sum_{i=1}^n W_i} \quad (5-6c)$$

5.1.2.8.2.1.7 Lateral seismic shear—The lateral seismic shear V_x acting at any level of the structure is determined by

$$V_x = \sum_{i=1}^x F_i \quad (5-7)$$

where F_i is from the top of the structure to the level under consideration.

5.1.2.8.2.1.8 Overturning—The structure should be designed to resist overturning effects caused by the seismic forces determined in Section 5.1.2.8.2.1.6. At any level, the increment of overturning moment in the level under consideration should be distributed to the various vertical force-resisting elements in the same proportion as the distribution of the horizontal shears to those elements.

The overturning moment at level x , M_x , should be determined from

$$M_x = \sum_{i=1}^x F_i(h_i - h_x) \quad (5-8)$$

where F_i = portion of the seismic base shear V induced at level i ; and h_i and h_x = height from the base to level i or x .

5.1.2.8.2.1.9 Accidental torsion—The design should include an accidental torsional moment caused by an assumed displacement of the mass from its actual location by a distance equal to 5% of the diameter of the elevated tank component. Torsional effects may be ignored when the torsional shear is less than 5% of the shear strength determined in Section 5.2.2.7.6.

5.1.2.8.2.2 Modal analysis procedure

5.1.2.8.2.2.1 Modeling—A mathematical model of the elevated tank, including the tank vessel, pedestal, and foundation, should be created that represents its spatial distribution of mass and stiffness. Stiffness properties of concrete elements should be based on uncracked sections. The equivalent weights of the impulsive and convective (sloshing) components of stored water may be determined from a fluid-structure interaction analysis performed with a suitable general purpose finite element computer program. The response of the mathematical model to the seismic response spectrum, including the calculation of modes and periods of natural vibration, and the calculation of thrusts, shears, and moments at desired levels in all structural components of the elevated tank, may be computed with a suitable computer program. Alternatively, such computations may be performed as described in Sections 5.1.2.8.2.2.2 through 5.1.2.8.2.2.5.

5.1.2.8.2.2.2 Modes—An analysis should be conducted to determine the natural modes of vibration for the

structure including the period of each mode, the modal shape vector Φ , the modal participation factor, and modal mass. The analysis should include a sufficient number of modes to obtain a combined modal mass participation of at least 90% of the actual mass in each of two orthogonal directions.

5.1.2.8.2.2.3 Periods—The required periods, mode shapes, and participation factors of the structure should be calculated by established methods of structural analysis for the fixed base condition using the masses and elastic stiffnesses of the seismic-force-resisting system.

5.1.2.8.2.2.4 Modal base shear—The portion of the base shear contributed by the m -th mode, V_m , should be determined from

$$V_m = C_{sm}W_m \quad (5-9a)$$

$$W_m = \frac{\left(\sum_{i=1}^n W_i \Phi_{im} \right)^2}{\sum_{i=1}^n W_i \Phi_{im}^2} \quad (5-9b)$$

where C_{sm} = modal seismic design coefficient determined by Eq. (5-10a); W_m = effective modal load; W_i = portion of the total effective load of the structure at level i ; and Φ_{im} = displacement amplitude at the i -th level of the structure when vibrating in its m -th mode.

The modal seismic design coefficient C_{sm} should be determined as follows:

For T_m less than or equal to T_s

$$C_{sm} = S_{DS} I / R \quad (5-10a)$$

For T_m greater than T_s but less than T_L

$$C_{sm} = S_{D1} I / T_m \quad (5-10b)$$

For T_m greater than T_L

$$C_{sm} = S_{D1} T_L I / R \quad (5-10c)$$

The total base shear V_t , determined by superposition of the modal shears computed with Eq. (5-9a), should not be less than 85% of the base shear computed with Eq. (5-4).

5.1.2.8.2.2.5 Modal forces—The modal force F_{xm} at each level should be determined by

$$F_{xm} = C_{vxm} V_m \quad (5-11a)$$

and

$$C_{vxm} = \frac{W_x \Phi_{xm}}{\sum_{i=1}^n W_i \Phi_{im}} \quad (5-11b)$$

where C_{vxm} = vertical distribution factor in the m -th mode; V_m = total design lateral force or shear at the base in the m -th mode; W_i and W_x = portion of the total effective load of the structure W_e located or assigned to level i or x ; Φ_{xm} = displacement amplitude at the x -th level of the structure when vibrating in its m -th mode; and Φ_{im} = displacement amplitude at the i -th level of the structure when vibrating in its m -th mode.

5.1.2.8.3 Freeboard—Freeboard may be provided for a sloshing wave height of

$$\delta_s = 0.5 D_t C_c I \quad (5-12)$$

where δ_s = height of the sloshing wave; D_t = tank diameter at the water surface; C_c = spectral acceleration of sloshing liquid in accordance with ACI 350.3-06, Chapter 9; and I is in accordance with ASCE/SEI 7-05 or as required by the applicable building code.

The roof-to-shell connection should be designed for the sloshing wave pressure when freeboard is less than calculated height of the sloshing wave.

5.1.2.9 Vertical load eccentricity—Eccentricity of dead and water loads that cause additional overturning moments to the structure as a whole should be accounted for in the design. The additional overturning moment is the dead and water load times the eccentricity e_g , which should not be taken as less than

$$e_g = e_o + \frac{g}{400} \quad (5-13a)$$

The minimum vertical load eccentricity e_o is 1 in. (25 mm).

Where tilting of the structure due to nonuniform settlement is estimated to exceed 1/800, the eccentricity e_g should not be taken as less than

$$e_g = e_o + g \left(\frac{1}{800} + \tan \theta_g \right) \quad (5-13b)$$

5.1.2.10 Construction loads—Temporary loads resulting from construction activity should be considered in the design of structural components required to support construction loads.

5.1.2.11 Creep, shrinkage, and temperature—The effects of creep, shrinkage, and temperature effects should be considered. ACI 209R provides guidance for these conditions.

5.1.3 Strength recommendations—concrete structure

5.1.3.1 General—Concrete portions of the structure should be designed to resist the applied loads that may act on the structure and should conform to this document.

5.1.3.1.1 Specified concrete strength—Specified compressive strength f'_c of concrete components should conform to Section 4.1.2.2.2 and applicable sections of Chapter 5.

5.1.3.1.2 Specified strength for reinforcement—The specified yield strength of reinforcement f_y should not exceed 60,000 psi (412 MPa).

5.1.3.2 Design methods

5.1.3.2.1 Strength design method—Structural concrete members not in contact with the stored water should be

proportioned for adequate strength in accordance with the strength design provisions of ACI 318 and this document. Structural concrete members in contact with the stored water should be proportioned for adequate strength in accordance with strength design provisions of ACI 350. Loads should not be less than the factored loads and forces in [Section 5.1.2.2.1](#). Strength reduction factors ϕ should conform to ACI 318 and to applicable sections of [Chapter 5](#).

5.1.3.2.2 Alternate design method—The alternate design method of ACI 318-02 or ACI 350 for concrete members not in contact with the stored water and ACI 350 for concrete members in contact with the stored water are acceptable methods for design. Unfactored load combinations should conform to [Section 5.1.2.2.2](#).

5.1.3.3 Minimum reinforcement

5.1.3.3.1 Flexural members—Where flexural reinforcement is required by analysis, the minimum reinforcement ratio ρ should not be less than $3\sqrt{f'_c}/f_y$ nor $200/f_y$ in inch-pound units ($0.25\sqrt{f'_c}/f_y$ nor $1.4/f_y$ in SI units). A smaller amount of reinforcement may be used if at every section the area of tensile reinforcement provided is at least one-third greater than that required by analysis.

5.1.3.3.2 Direct tension members—For nonprestressed structural elements in regions of direct tension exceeding 100 psi (0.7 MPa), the minimum reinforcement ratio ρ_g should not be less than $5\sqrt{f'_c}/f_y$ ($0.42\sqrt{f'_c}/f_y$). A smaller amount of reinforcement may be used if the area of tensile reinforcement provided is at least one-third greater than that required by analysis.

5.1.4 Serviceability recommendations—concrete structure

5.1.4.1 General—Concrete portions of the elevated tank should conform to this document to ensure adequate performance at service loads. The following should be considered:

- (a) Deflection of flexural beam or slab elements should conform to ACI 318 or 350, as applicable;
- (b) Control of cracking should conform to [Section 5.1.4.2](#) and applicable sections of [Chapter 5](#); and
- (c) Settlement of foundations should conform to [Sections 6.3](#) and [6.5](#).

5.1.4.2 Distribution of flexural and tension reinforcement—Distribution of flexural and tension reinforcement to control cracking should be considered at locations where analysis indicates flexural tension or direct tension stresses occur.

The spacing s of reinforcement closest to a surface in tension should not exceed that given by

$$s = 540/f_s - 2.5c_c \quad [94.6/f_s - 2.5c_c \text{ in SI units}] \quad (5-14)$$

but not greater than $12(36/f_s)$ [$12(6.3/f_s)$ in SI units], where c_c is clear cover from the nearest surface in tension to the surface of the flexural tension reinforcement (in. [mm]).

Calculated stress in reinforcement, f_s , is for Load Combination S1.1 in [Section 5.1.2.2.2.1.1](#). Alternatively, f_s may be taken as 60% of the specified yield strength f_y .

5.2—Design of components common to both composite and concrete tank types

5.2.1 Foundations

5.2.1.1 General

5.2.1.1.1 Scope—This section covers structural recommendations for foundations used for elevated concrete and composite steel-concrete tanks. Geotechnical recommendations are described in [Chapter 6](#).

5.2.1.1.2 Foundation types—Shallow and deep foundations used for support of elevated concrete and composite steel-concrete tanks are shown in [Fig. 5.1](#).

5.2.1.2 Design

5.2.1.2.1 Design code—Foundations should be designed in accordance with ACI 318, except as modified herein.

5.2.1.2.2 Loads—The loads and load combinations should conform to [Section 5.1.2](#).

5.2.1.3 Overturning—The foundation should be of sufficient size and strength to resist overturning forces resulting from wind, seismic, and differential settlement loads. Where high groundwater occurs, the effects of buoyancy should be included. The stability ratio (ratio of the resisting moment to overturning moment) should be greater than 1.5 for unfactored service load forces.

5.2.1.3.1 Resisting gravity load—The gravity service load P_s that resists overturning is the dead load D for wind loading, dead plus water loads $D + F$ for full tank seismic loading, and dead load D for empty tank seismic loading.

5.2.1.3.2 Shallow foundations—The resisting moment is the product of the gravity service loads P_s and the distance from the foundation centerline to the centroid of the resisting contact pressure. The resisting contact pressure should not exceed the ultimate bearing capacity q_r defined in [Section 6.4.1](#) or as specified in a project-specific geotechnical report as an allowable edge pressure.

5.2.1.3.3 Deep foundations—The resisting moment is the product of the gravity service loads P_s and the distance from the foundation centerline to the centroid of the resisting group of piles or drilled piers. The maximum load acting on a deep foundation unit should not exceed the ultimate capacity Q_r defined in [Section 6.5.1](#) or as specified in a project-specific geotechnical report for allowable capacity in piles for short-term overturning loading. Where piles or piers are capable of resisting tension loads and are adequately connected to the superstructure, the tension capacity may be considered in assessing the stability ratio.

5.2.1.4 Shallow foundations

5.2.1.4.1 Annular ring foundations—Torsional effects and biaxial bending should be considered when the centroid of the footing and the centerline of the pedestal wall do not coincide. The footing may be designed as a one-way beam element that is a sector of an annulus when the centroids coincide, and the circumferential biaxial effects may be excluded.

5.2.1.4.2 Raft foundations—The portion inside the concrete pedestal is designed as a two-way slab, and the cantilever portion may be designed as a one-way strip or as a continuation of the two-way interior slab.

5.2.1.5 Deep foundations

5.2.1.5.1 Structural design—The structural design of piles or piers should be in accordance with building codes adopted in the jurisdiction of the work. Recommendations

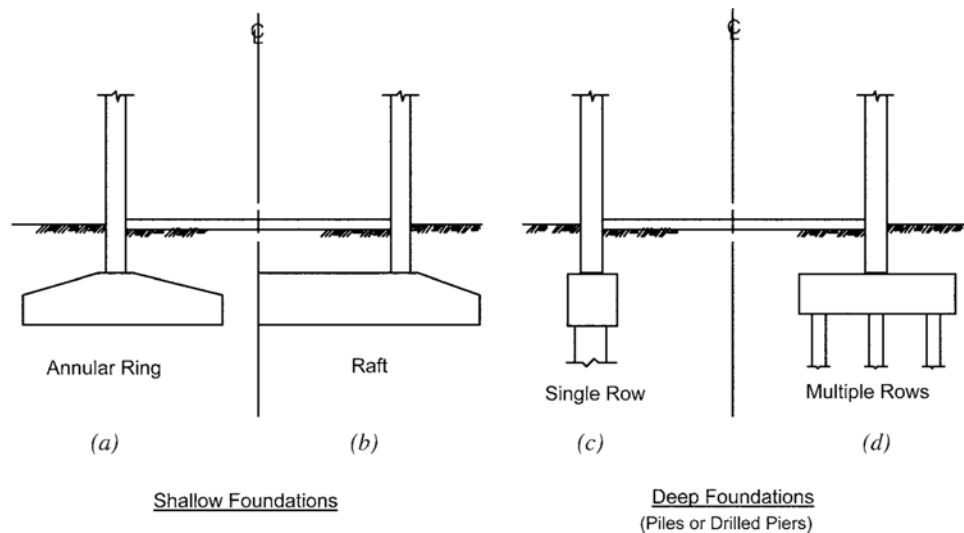

Fig. 5.1—Foundation types.

for design and construction of drilled piers are found in ACI 336.3R.

5.2.1.5.2 Lateral load effects on piles or piers—The effect of lateral loads should be considered in the structural design of piles or piers. Battered piles are not recommended to resist seismic lateral forces due to their detrimental effect from seismic accelerations which result in increased overall structural stiffness and potentially local shear failure.

5.2.1.5.3 Lateral load effects on pile or pier caps—The pile or pier cap should be designed for the shear, torsion, and bending moments that occur when piles or drilled piers are subject to lateral loads.

5.2.1.5.4 Lateral seismic loads—Piling should be designed to withstand deformations from earthquake ground motions and structure response in accordance with Sections 12.13.6.3 and 12.13.6.7 of ASCE/SEI 7-05.

5.2.1.6 Design details

5.2.1.6.1 Load transfer—Forces and moments at the base of the concrete pedestal wall should be transferred to the foundation by bearing on concrete, by reinforcement and dowels, or both. The connection between the pile or pier cap and piles or piers should be designed for bearing, shear, and uplift forces that occur at this location.

5.2.1.6.2 Development of reinforcement—Flexural steel should be checked for proper development at all sections. Hooks may be used to develop footing reinforcement where the footing extension is not long enough to fully develop straight bars.

5.2.1.6.3 Serviceability—The service load tension reinforcement steel stress f_s at sections of maximum moment should not exceed 30,000 psi (205 MPa) for load case S1.1, dead and water loads only. Alternatively, sections of maximum moment should follow the recommendations of Section 5.1.4.2.

5.2.1.6.4 Sloped foundations—When tapered top surfaces are used, footing shape should be used to determine shear and moment capacities.

5.2.1.6.5 Concrete cover—The actual clear distance between the edge of foundation and edge of a pile or pier should not be less than 3 in. (75 mm) after installation.

5.2.1.6.6 Pedestal wall openings—The local effects at large openings in the concrete pedestal wall below grade should be considered when the distance from the top of the foundation to the bottom of the opening is less than one-half the opening width. The foundation should be designed for the redistribution of loads across the unsupported opening width.

5.2.1.6.7 Seismic design details—Where design for seismic loads is required, details of concrete piles and concrete-filled piles should conform to the requirements of Section 14.2.3 of ASCE/SEI 7-05.

5.2.2 Pedestal

5.2.2.1 General—Design of the pedestal should be in accordance with ACI 318 except as modified in this document. Other methods of design and analysis may be used. The minimum wall reinforcement should not be less than required by Table 5.2. Portions of the wall subjected to significant flexure or direct tension loads should conform to Sections 5.1.3.3 and 5.1.4.2.

5.2.2.2 Details of wall and reinforcement

5.2.2.2.1 Minimum wall thickness—Wall thickness h_r should not be less than 8 in. (200 mm). The wall thickness h_r is exclusive of any rustications, fluting, or other architectural relief.

5.2.2.2.2 Specified compressive strength—The specified compressive strength of concrete f'_c should not be less than required in Section 4.1.2.2.2 nor greater than 5000 psi (35 MPa).

5.2.2.2.3 Minimum reinforcement—Wall reinforcement should conform to Table 5.2. Not more than 60% nor less than 50% of the minimum reinforcement in each direction specified in Table 5.2 should be distributed to the exterior face, and the remainder to the interior face.

5.2.2.2.4 Concrete cover—Concrete cover to reinforcement should conform to Section 4.1.4.3.1.

5.2.2.2.5 Transverse reinforcement—Crossties are required in walls at locations where:

Table 5.2—Minimum wall reinforcement recommendations

Reinforcement parameter	Seismic coefficient $S_{D1} < 0.20$		Seismic coefficient $S_{D1} \geq 0.20$
	$f_c < 1$ ksi (7 MPa) [†]	$f_c \geq 1$ ksi (7 MPa) [†]	
Minimum reinforcement ratio: [*]			
Vertically: No. 11 (No. 36) bar and smaller	0.0015	0.005	0.005
Horizontally: No. 5 (No. 16) bar and smaller No. 6 (No. 19) bar and larger	0.0020 0.0025	0.0025 0.0025	0.0025 0.0030
Type of deformed bars permitted:			
Deformed bars	ASTM A615/A615M or A706/A706M		ASTM A615/A615M or A706/A706M
Plain or deformed welded wire reinforcement	ASTM A185/A185M or A497/497M		‡
Maximum specified yield strength f_y permitted	60,000 psi (420 MPa)		60,000 psi (420 MPa)

^{*}Minimum reinforcement ratio applies to gross concrete area.

[†]Minimum reinforcement ratio for $S_{D1} < 0.20$ depends on f_c , the maximum compressive fiber stress based on actual axial plus flexure stress resulting on gross concrete section.

[‡]Mill tests demonstrating conformance to ACI 318 are required when ASTM A615/A615M bars are used for reinforcement resisting earthquake-induced flexural and axial forces. ASTM A615/615M, ASTM A185/A185M, and ASTM A497/A497M are permitted for reinforcement resisting other forces, and for shrinkage and temperature steel.

Note: When pedestal is used with accommodations for other occupancy requirements, that is, floors for lab or office space, these values may need to be increased, especially if the Seismic Design Categories of D, E, or F result from these occupancies.

(a) Vertical reinforcement is required by design calculations as compression reinforcement and the resulting reinforcement design ratio ρ_g is 0.005 or more; and

(b) Concentrated plastic hinging or inelastic behavior is expected during seismic loading.

Where cross-ties are required, the size and spacing should conform to ACI 318-05, Section 7.10, and Section 21.4.4 in seismic areas.

5.2.2.3 Vertical load capacity

5.2.2.3.1 Design load—The factored axial wall load per unit of circumference P_{uw} should conform to [Section 5.1.2.2.1](#).

5.2.2.3.2 Axial load strength—Design for vertical load capacity per unit length of circumference should be based on

$$P_{uw} \leq \phi P_{mw} \quad (5-15)$$

where $\phi = 0.65$.

5.2.2.3.3 Nominal axial strength—Without compression reinforcement, the nominal axial load strength per unit length of circumference of pedestal, P_{mw} , should not exceed

$$P_{mw} = C_e [0.85f'_c] A_w \quad (5-16)$$

Where compression reinforcement is provided, the nominal axial load strength per unit length of circumference of pedestal, P_{mw} , should not exceed

$$P_{mw} = C_e [0.85f'_c (A_w - A_s) + f_y A_s] \quad (5-17)$$

C_e is an eccentricity coefficient that accounts for the resultant of factored axial load P_{uw} to be eccentric to the centroid of the pedestal thickness

$$C_e = 1 - \frac{2e}{h} \quad \text{with } 0.65 \leq C_e \leq 0.80 \quad (5-18)$$

where e is the eccentricity of P_{uw} .

In Eq. (5-16) and (5-17), the eccentricity coefficient C_e is 0.65. When the eccentricity of P_{uw} is determined by

rational analysis including through wall thickness moment, C_e in Eq. (5-17) may be increased accordingly to the maximum value of 0.80. When the effects of vertical load and bending caused by the presence of slabs, diaphragms, or domes and other discontinuities are determined by rational analysis, the pedestal wall should be designed as a column of unit circumferential width according to ACI 318-05, Section 14.4, and the applicable sections of ACI 318-05, Chapter 10. The vertical wall reinforcement should be equal to or greater than $0.005A_g$ and need not be enclosed by lateral ties when the conditions of ACI 318-05, Section 14.3.6, are satisfied.

5.2.2.3.4 Foundation rotation—Bending in the pedestal wall due to radial rotation of the foundation should be included in the pedestal design, if applicable.

5.2.2.4 Circumferential bending

5.2.2.4.1 General—Horizontal reinforcement should be provided in each face for circumferential moments arising from ovaling of the wall due to variations in wind pressures around the wall circumference and discontinuities. The factored design wind ovaling moment should be determined by multiplying M_h by the wind load factor defined in [Section 5.1.2.2.1](#).

5.2.2.4.2 Design moment M_h —At horizontal sections through the wall that are remote from a level of effective restraint where circularity is maintained, the service load wind ovaling moment per unit of height, M_h , may be determined from

$$M_h = 0.052p_z d_w^2 \quad (5-19)$$

where p_z is calculated in accordance with [Section 5.1.2.6.2](#). The quantity $p_z d_w^2$ is expressed in units of force. Other rational analyses may be used.

5.2.2.4.3 Vertical distribution—The wind ovaling moment M_h may be considered to vary linearly from zero at a diaphragm elevation to the full value at a distance $0.5d_w$ from the diaphragm.

5.2.2.5 Openings in walls

5.2.2.5.1 General—The effects of openings in the wall should be considered in the design. Wall penetrations having

a horizontal dimension of 3 ft (0.9 m) or less and a height of $12h_r$ or less may be designed in accordance with Section 5.2.2.5.2. Otherwise, the design should conform to Sections 5.2.2.5.3 through 5.2.2.5.5.

5.2.2.5.2 Simplified method—Where detailed analysis is not required, minimum reinforcement around the opening is the larger amount determined by:

(a) Vertical and horizontal reinforcement interrupted by the opening should be replaced by reinforcement having an area not less than 120% of the interrupted reinforcement, half placed each side of the opening, and extending past the opening a distance not less than half the transverse opening dimension; and

(b) An area each side of the opening equal to $0.75b_d$ should be evaluated for vertical load capacity and reinforced as required. The load acting on this area should be half the vertical force interrupted by the opening plus the average vertical load in the wall at midheight of the opening.

5.2.2.5.3 Effective column—The wall adjacent to an opening should be designed as a braced column in accordance with ACI 318 and the following:

(a) Each side of the opening should be designed as a reinforced concrete column having an effective width equal to the smaller of $5h$, 6 ft (1.8 m), or $0.5b_d$;

(b) The effective column should be designed to carry half the vertical force interrupted by the opening plus the average vertical load in the wall at midheight of the opening;

(c) The effective unsupported column length k should not be less than $0.85h_d$;

(d) The effective columns should be analyzed by the slender column procedures of ACI 318 and reinforced accordingly with bars on the inside and outside faces of the wall. Transverse reinforcement should conform to ACI 318-05, Section 7.10, and Section 21.4.4 in seismic areas; and

(e) The effective column should be checked for the effects of vehicle impact if the opening is to be used as a vehicle entrance through the pedestal wall.

5.2.2.5.4 Pilasters—Monolithic pilasters may be used adjacent to openings. Such pilasters should extend above and below the opening $0.5h_d$ to affect a smooth transition of forces into the wall without creating excessive local stress concentrations. The transition zone where pilasters are terminated should be thoroughly analyzed and additional reinforcement added if required for local stresses. The reinforcement ratio ρ_g should not be less than 0.01.

5.2.2.5.5 Horizontal reinforcement—Additional horizontal reinforcement should be provided above and below openings in accordance with Eq. (5-20) and should be distributed over a height not exceeding $3h$

$$A_s = \frac{0.14P_{uw}b_d}{\phi f_y} \quad (5-20)$$

where $\phi = 0.9$. P_{uw} applies at the level of the reinforcement being designed. The quantity $P_{uw}b_d$ is expressed in pounds (N). The reinforcement yield strength f_y used in Eq. (5-17) should not exceed 60,000 psi (420 MPa).

5.2.2.5.6 Development of reinforcement—Additional reinforcement at openings is to be fully developed beyond the opening in accordance with ACI 318. Additional horizontal reinforcement should project at least half a development length beyond the effective column or pilaster width of Sections 5.2.2.5.3 or 5.2.2.5.4.

5.2.2.5.7 Local effects below openings—Where the combined height of wall and foundation below the opening is less than one-half the opening width, the design should conform to Section 5.2.1.6.6.

5.2.2.6 Radial shear design—Design of the concrete pedestal wall for radial shear forces should conform to Chapter 11 of ACI 318-05.

5.2.2.7 In-plane shear design

5.2.2.7.1 General—Design of the concrete pedestal wall for in-plane shear forces caused by wind or seismic forces should follow the recommendations of Sections 5.2.2.7.2 through 5.2.2.7.8.

5.2.2.7.2 Design forces—The factored shear force V_u and simultaneous factored moment M_u should be obtained from the lateral load analysis for wind and seismic forces.

5.2.2.7.3 Shear force distribution—In-plane shear force distribution in the concrete pedestal wall should be determined by a method of analysis that accounts for the applied loads and structure geometry. Lateral loads should be distributed to the lateral-load-resisting elements in proportion to their relative stiffness. The effective shear area A_{cv} determined in Section 5.2.2.7.4 may be used when the ratio of openings to effective shear wall width ψ does not exceed 0.5.

5.2.2.7.4 Effective shear area—The effective horizontal concrete wall area A_{cv} resisting in-plane shear force V_u may be considered to be resisted by two equivalent shear walls parallel to the direction of the applied load, with total area not greater than

$$A_{cv} = (2 - \psi)b_v h_r \quad (5-21)$$

where

$$\psi = \frac{b_x}{b_v} \quad (5-22)$$

The length b_v of each equivalent shear wall should not exceed $0.78d_w$. Dimensions b_v , b_x , d_w , and h_r are expressed in inch (mm) units.

5.2.2.7.5 Maximum shear—In-plane shear V_u should not exceed $8\sqrt{f'_c} A_{cv}$ (inch-pound units) [$(2/3)\sqrt{f'_c} A_{cv}$ (SI units)].

5.2.2.7.6 Shear strength—Design for in-plane shear should be based on

$$V_u \leq \phi V_n \quad (5-23)$$

where $\phi = 0.75$.

The nominal shear strength V_n should not exceed the shear force calculated from

$$V_n = (\alpha_c \sqrt{f'_c} + \rho_h f_y) A_{cv} \quad (5-24)$$

where

$$\alpha_c = 6 - \frac{2.5 M_u}{V_u d_w}$$

but not less than 2.0 nor greater than 3.0 (inch-pound units).

$$\alpha_c = 0.5 - \frac{0.21 M_u}{V_u d_w}$$

but not less than 1/6 nor greater than 1/4 (SI units).

The variables M_u and V_u are the total factored moment and shear occurring simultaneously at the section under consideration, and ρ_h is the ratio of horizontal distributed shear reinforcement on an area perpendicular to A_{cv} .

5.2.2.7.7 Design location—The nominal shear strength V_n should be determined at a distance above the foundation equal to the smaller of $0.39d_w$ or the distance from the foundation to midheight of the largest opening, or set of openings with the largest combined ψ .

5.2.2.7.8 Reinforcement—Minimum reinforcement should conform to [Table 5.2](#). In regions of high seismic risk, reinforcement should also conform to the following:

(a) When V_u exceeds $\sqrt{f'_c} A_{cv}$ ($\sqrt{f'_c} A_{cv}/12$), the minimum horizontal and vertical reinforcement ratios should match [Table 5.2](#) for seismic coefficient $S_{D1} \geq 0.20$;

(b) When V_u exceeds $2\sqrt{f'_c} A_{cv}$ ($\sqrt{f'_c} A_{cv}/6$), two layers of reinforcement should be provided; and

(c) Where shear reinforcement is required for strength, the vertical reinforcement ratio ρ_v should not be less than the horizontal reinforcement ratio ρ_h .

5.3—Design of components specific to composite tanks

5.3.1 Tank floors

5.3.1.1 General

5.3.1.1.1 Scope—This section covers design of concrete flat slab and dome floors of uniform thickness used as steel vessel floors. Section 5.3.2 discusses the interaction effects of the concrete support elements and the steel vessel that should be considered in the design.

5.3.1.1.2 Loads—The loads and load combinations should conform to [Section 5.1.2.2](#). Loads acting on the vessel floor are distributed dead and water loads, and concentrated loads from the access tube, piping, and other supports.

5.3.1.2 Flat slab floors

5.3.1.2.1 Design—Concrete slab floors covered by a steel liner should be designed in accordance with ACI 318, except as modified herein. Specified compressive strength of concrete, f'_c , should not be less than required in [Section 4.1.2.2.2](#).

5.3.1.2.2 Slab stiffness—The stiffness of the slab should be sufficient to prevent rotation under dead and water loads that could cause excessive deformation of the attached

wall and steel vessel elements. The stiffness of the slab should be calculated using the gross concrete area and one-half the modulus of elasticity of concrete.

5.3.1.2.3 Minimum reinforcement—Where tensile reinforcement is required by analysis, the minimum reinforcement should conform to [Table 5.2](#).

5.3.1.2.4 Crack control—Distribution of tension reinforcement required by analysis should conform to [Section 5.1.4.2](#).

5.3.1.3 Dome floors

5.3.1.3.1 Design—Concrete dome floors should be designed on the basis of elastic shell analysis. Consideration of edge effects that cause shear and moment should be included in the analysis and design. Specified compressive strength of concrete, f'_c , should not be less than required in [Section 4.1.2.2.2](#) nor greater than 5000 psi (35 MPa).

5.3.1.3.2 Thickness—The minimum thickness h_s of a uniform thickness dome should be computed by Eq. (5-25) using any consistent set of units. Buckling effects should be considered when the radius-to-thickness ratio exceeds 100.

$$h_s = 1.5R_d \frac{w_u}{\phi f'_c} \quad \text{and not less than 8 in. (200 mm)} \quad (5-25)$$

where w_u and f'_c are expressed in the same units, and h_s and R_d are expressed in inches (mm).

The factored distributed w_u is the mean dead and water load (Load Combination U1.1). The strength reduction factor ϕ is 0.65.

5.3.1.3.3 Minimum reinforcement—Where tensile reinforcement is required by analysis, the minimum reinforcement should conform to [Table 5.2](#).

5.3.1.3.4 Crack control—Distribution of tension reinforcement required by analysis should conform to [Section 5.1.4.2](#).

5.3.2 Concrete-to-steel vessel interface

5.3.2.1 General

5.3.2.1.1 Scope—This section covers design of the interface region of elevated composite steel-concrete tanks.

5.3.2.1.2 Interface region—The interface region includes those portions of the concrete pedestal, vessel floor, ringbeam, and steel vessel affected by the transfer of forces from the vessel floor and steel vessel to the concrete support elements.

5.3.2.1.3 Details of wall and reinforcement—The details at the top of the concrete pedestal and support elements are generally proprietary and differ from one steel vessel manufacturer to another. The loads and forces acting at the interface, and specific recommendations are covered in [Sections 5.3.2.3](#) through [5.3.2.5](#).

5.3.2.2 Design considerations

5.3.2.2.1 Load effects—The following load effects in combination with dead and live loads should be considered in design of the interface region:

- Loading caused by varying water level;
- Seismic and wind forces that cause unsymmetrical reactions at the interface region;

(c) Construction loads and attachments that cause concentrated loads or forces significantly different than the dead and water loads;

(d) Short- and long-term translation and rotation of the concrete at the interface region, and the effect on the membrane action of the steel tank;

(e) Eccentricity of loads, where the point of application of load does not coincide with the centroid of the resisting elements;

(f) Effect of restrained shrinkage and temperature differentials;

(g) Transfer of steel vessel loads to the concrete pedestal and support elements; and

(h) Anchorage attachments when required for uplift loads.

5.3.2.2.2 Analysis—Analysis should be by finite difference, finite element, or similar analysis programs that accurately model the interaction of the intersecting elements. The analysis should recognize:

(a) The three-dimensional nature of the problem;

(b) The nonlinear response and change in stiffness associated with tension and concrete cracking, and the redistribution of forces that occur with stiffness changes;

(c) The effect of concrete creep and shrinkage on deformations at the interface; and

(d) The sensitivity of the design to initial assumptions, imperfections, and construction tolerances. Appropriate allowance for variations arising from these effects should be included in the analysis.

5.3.2.3 Dome floors

5.3.2.3.1 Design considerations—The interface region should be analyzed for in-plane axial forces, radial and tangential shear, and moment for all loading conditions. Eccentricity arising from geometry and accidental imperfections in the construction process should be included in the analysis. Various stages of filling, wind and seismic shear, and overturning effects should be considered when determining the design loads. Particular attention should be given to the radial shear and moment in shell elements caused by edge restraint effects.

5.3.2.3.2 Ringbeam compression—The maximum service load compression stress in the ringbeam due to direct horizontal thrust forces should not exceed $0.30f'_c$.

5.3.2.3.3 Fill concrete—Concrete used to connect the steel tank to the concrete pedestal and support elements should have a specified compressive strength not less than the concrete to which it connects or its own design compressive strength, whichever is greater.

5.3.2.3.4 Slab floors—The pedestal, vessel floor, and steel vessel should be analyzed for in-plane axial forces, radial shear, and moment for all loading conditions. The degree of fixity of the steel vessel to the tank floor should be considered.

5.3.2.5 Reinforcement details—Reinforcement in concrete elements in the interface region should be sufficient to resist the calculated loads, but should not be less than the following:

(a) The minimum reinforcement ratio ρ_g should not be less than 0.0025 in regions of compression and in regions of tension stress not exceeding $3\sqrt{f'_c}$;

(b) Where tension reinforcement is required by analysis, the minimum reinforcement should conform to [Section 5.1.3.3](#); and

(c) Distribution of tension reinforcement required by analysis should conform to [Section 5.1.4.2](#).

5.3.3 Tank vessel—Materials, design, fabrication, and construction of steel tank vessels should comply with recognized standards. Applicable sections of AWWA D100 can be used.

5.3.3.1 Design—Analysis of steel shells is usually based on membrane theory of thin elastic shells. It is applicable where bending stiffness is sufficiently small that the shells are physically incapable of resisting bending, or the shells are flexurally stiff but loaded and supported in a manner that avoids the introduction of significant bending strains. Membrane analysis includes analysis of boundary elements such as tension or compression rings that resist unbalanced edge forces at shell discontinuity junctures. Procedures based on strain compatibility are used for analysis at shell discontinuities where bending stresses may be significant. Classical shell theory, simplified mathematical models, or numerical solutions using the finite element method, finite differences, or numerical integration techniques can be used to determine in-plane membrane forces, shear, and flexure. An equivalent stress formulation, such as the von Mises stress intensity, should be used to evaluate calculated working stresses based on these procedures. Maximum equivalent stress should be less than 60% of the yield strength for gravity loads, and 80% for load combinations including wind and seismic loads. Higher stresses, including localized yielding near the discontinuity, are acceptable when it can be demonstrated that higher stresses do not lead to progressive collapse of the overall structure, and that general stability is maintained. Weldments located near highly stressed discontinuity junctures that are subjected to significant stress should be designed for cyclic loading.

5.4—Design of components specific to all-concrete tanks

5.4.1 Concrete tank vessel

5.4.1.1 General—The tank vessel may consist of the elements shown in [Fig. 1.1](#), including the transition, vessel cone, vessel cylinder, dome roof, interior access shaft, and interior platform. Design of the vessel elements should be in accordance with ACI 350 and 373R, except as modified in [Sections 5.4.1.2 through 5.4.1.7](#).

The structural elements of the vessel can be separated into three categories: elements that are directly post-tensioned; elements influenced by post-tensioning; and elements that are completely nonprestressed. Most of the meridional extent of the vessel cone and vessel cylinder is directly post-tensioned and should meet the requirements of an ACI 350 post-tensioned water-retaining structure. The lowest portion of the vessel cone and uppermost portion of the vessel cylinder, transition, and dome roof are indirectly affected by post-tensioning and thus act as a hybrid between full post-tensioned components and nonprestressed components. This special type of component requires judgment in the application

of ACI 350 requirements in that these elements should meet the ACI 350 nonprestressed requirements, but not all of ACI 350 post-tensioned requirements, such as residual compression. The interior vessel access shaft and vessel platform (Fig. 1.1) are strictly nonprestressed components and should meet ACI 350 cast-in-place nonprestressed requirements. Due to the resulting large thicknesses involved in these components, it is important to abide by the ACI 350 maximum of 12 in. (300 mm) spacing for nonprestressed principal reinforcement. Also, to provide confinement and reinforcement to resist peak stresses around blockouts and openings, spacing of reinforcement in these areas should not exceed 6 in. (150 mm).

5.4.1.2 Transition—A reinforced concrete transition section should be provided to adequately and smoothly distribute stresses between the pedestal, vessel access shaft, and cone. Sufficient thickness and steel reinforcement should be provided to accommodate stresses within this area. Ties should continue within the transition section from both the pedestal and the vessel cone. Such ties should match the adjoining structural element tie area and spacing so as to provide a smooth transfer of axial stresses and shears. This component should meet all the nonprestressed requirements of ACI 350, such as those for cover and minimum area of reinforcement.

This element is usually conical in shape; thus, it will resist the internal vessel pressure loads in compression both meridionally and radially. The thrust from the vessel cone from the internal vessel pressure, the vessel cone post-tensioning, and the relative stiffness of each of the joined components will influence the design of this component. Flexure and shear should also be checked at the interface with the pedestal below and with the access shaft above. Due to the thickness of the component at the pedestal interface required to ensure a smooth transition in stresses, minimum steel requirements will usually control the design. Reinforcement required at the top of this component may be controlled by flexure at the access shaft intersection, though it also is often controlled by minimum reinforcement requirements.

5.4.1.3 Vessel cone—The vessel cone may be the main containment element of the tank. It should be a post-tensioned concrete structural element when it acts as the main containment element.

The minimum thickness of the cone at the intersection with the transition should meet the requirements of ACI 350 for flexure and shear. Current designs of these components indicate that the minimum thickness at the intersection with the transition should be 18 in. (450 mm), tapering to a minimum of 16 in. (400 mm) at the top of the cone where it intersects with the cylindrical wall.

The cone should be post-tensioned both circumferentially and meridionally to maintain at least 125 psi (0.86 MPa) residual compression in accordance with ACI 350 with the tank filled with water except that, within the vicinity of the transition, circumferential residual compression may not be required due to the resistance to movement by the stiff intersection of the cone with the transition. Also, due to the large thickness required in this region, the 125 psi (0.86 MPa) residual compression requirement should be evaluated to ensure that post-tensioning is not causing any undue detrimental

effects, such as high flexure resulting in meridional tension on the inside face at the base of the cone. If the latter situation occurs, then the residual compression and the meridional bending in the lower region of the cone should be balanced to produce a design in which compression from post-tensioning is helpful in resisting hydrostatic load, but not so large as to produce excessive flexure at the base of the cone.

The minimum area of meridional reinforcement in all locations of the cone should meet ACI 350 requirements, but should not be less than 0.005 times the concrete area due to the high compressive stresses in this area that result from the cone's response to the internal vessel pressure. The minimum area of circumferential reinforcement in all locations of the cone should also meet ACI 350 requirements, but not be less than 0.0025 times the concrete area, again due to high compressive stresses in this component. The reinforcement next to the concrete faces in both the circumferential and meridional directions should be not less than one-half the aforementioned requirements.

Ties within the cone in the vicinity of the transition section should be provided for both shear and compression steel confinement. Such ties should extend from the transition section to the location where reinforcement required by design calculations is not larger than 0.005 times the gross concrete area and where vertical compression reinforcement is not required. In addition, ties should extend for 2 ft (0.6 m) into the region where minimum steel is required. Area and spacing of ties should be as required by design, and they should be placed to meet the requirements of ACI 350-06, Sections 7.10.5, 11.5.4.1, and 11.5.5.3, as a minimum.

Blockouts for circumferential post-tensioning may be placed on the inside or outside of the cone section.

All circumferential reinforcement interrupted by the circumferential post-tensioning blockouts should be displaced to each side of the blockout. Meridional reinforcement interrupted by the circumferential post-tensioning blockouts should be replaced with an equivalent amount of reinforcement. One-half of the displaced reinforcement should be located near each end of the blockout and extend past each side of the blockout a distance equal to a Class B splice.

All construction joints in the cone should incorporate a minimum 6 in. (150 mm) PVC waterstop plus a permeable grout tube, which should be grouted as a final construction activity.

5.4.1.4 Vessel cylindrical wall—The cylindrical wall above the vessel cone may be the topmost containment element. Its upper part may serve as the circumferentially post-tensioned concrete dome ring to support the dome roof thrust. Its lower part may serve as the cylindrically post-tensioned concrete upper cone ring to support thrust at the top of the cone.

The cylindrical wall should be sufficiently thick to contain the post-tensioning strands required to resist the dome and upper cone thrusts as well as the pressure of the stored water. The typical minimum thickness of this structural element is 24 in. (600 mm).

The cylindrical wall should be post-tensioned circumferentially to maintain at least 125 psi (0.86 MPa) residual

compression in accordance with ACI 350 with the vessel filled with water as defined in Section 5.1.2.4 of this document.

Minimum meridional and circumferential reinforcement of this prestressed element should meet ACI 350 requirements, but not be less than 0.0025 times the concrete area, with at least one-half of this amount near each face.

Blockouts for circumferential post-tensioning may be placed on either the outside or inside of the cylindrical wall. Pilasters for circumferential post-tensioning may also be used on the exterior of the cylindrical wall.

All meridional and circumferential reinforcement interrupted by the circumferential post-tensioning blockouts should be displaced to each side of the blockout and should extend past the blockout so as to be fully developed beyond the closest face of the blockout in each direction. In addition, a minimum of six No. 3 (10M) closed ties should enclose the area of displaced circumferential reinforcement in between blockouts (Fig. 5.2 and 5.3).

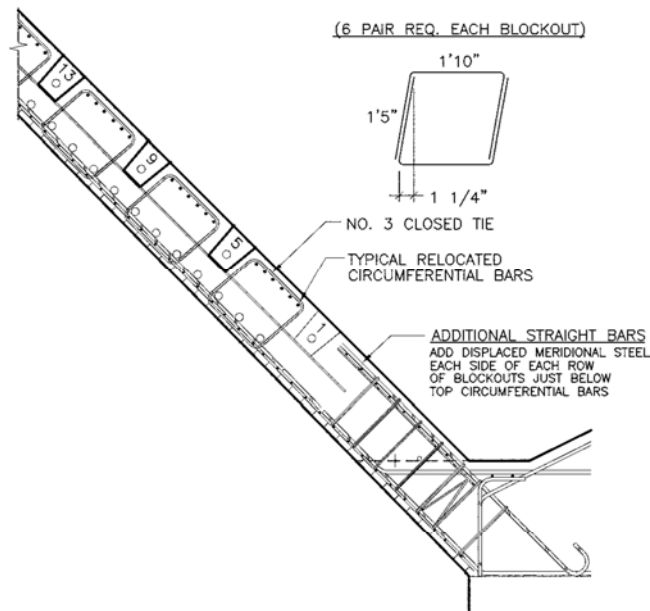

Fig. 5.2—Section at blockouts.

5.4.1.5 Dome roof—The dome roof may be of reinforced cast-in-place concrete. The entire dome thrust should be resisted by post-tensioning located in the dome ring portion of the cylindrical wall component. The thickness of the tank dome should be determined in accordance with ACI 350, and should not be less than 4 in. (100 mm) thick. The minimum area of reinforcement should be in accordance with ACI 350, but not less than 0.0025 times the cross-sectional area in both directions.

5.4.1.6 Vessel access shaft (Fig. 1.1)—Access to a platform within the vessel or to a hatch in the dome may be by way of a minimum 3 ft 6 in. (1 m) inside-diameter reinforced cast-in-place concrete circular shell shaft extending above the transition to the platform. Vessel access shaft minimum wall thickness should be 12 in. (300 mm) and should be in conformance with ACI 350 requirements for nonprestressed concrete.

The minimum area of vertical reinforcement should be in accordance with ACI 350, but not less than 0.005 times the cross-sectional area. The minimum area of circumferential reinforcement should be in accordance with ACI 350, but not less than 0.0025 times the cross-sectional area. The reinforcement near each face should be not less than one-half the aforementioned requirement, regardless of how much reinforcement is in an opposite face due to design requirements.

5.4.1.7 Vessel access platform (Fig. 1.1)—A reinforced concrete platform within the vessel just above the high water line, if it is supplied, should be supported by the vessel access shaft. The minimum slab thickness should be 6 in. (150 mm) with plan dimension as required for functionality. This component should meet all nonprestressed requirements of ACI 350, even though it is not a water-retaining element, because it is in a potentially high-corrosion environment. The minimum reinforcement in each direction should be 0.006 times the cross-sectional area in accordance with ACI 350 requirements.

CHAPTER 6—GEOTECHNICAL RECOMMENDATIONS

6.1—General

6.1.1 Scope—This section identifies the recommendations related to foundation capacity and settlement limits.

6.1.2 Geotechnical investigation—A subsurface investigation should be made to the depth and extent to which the tank foundation will significantly change the stress in the soil or

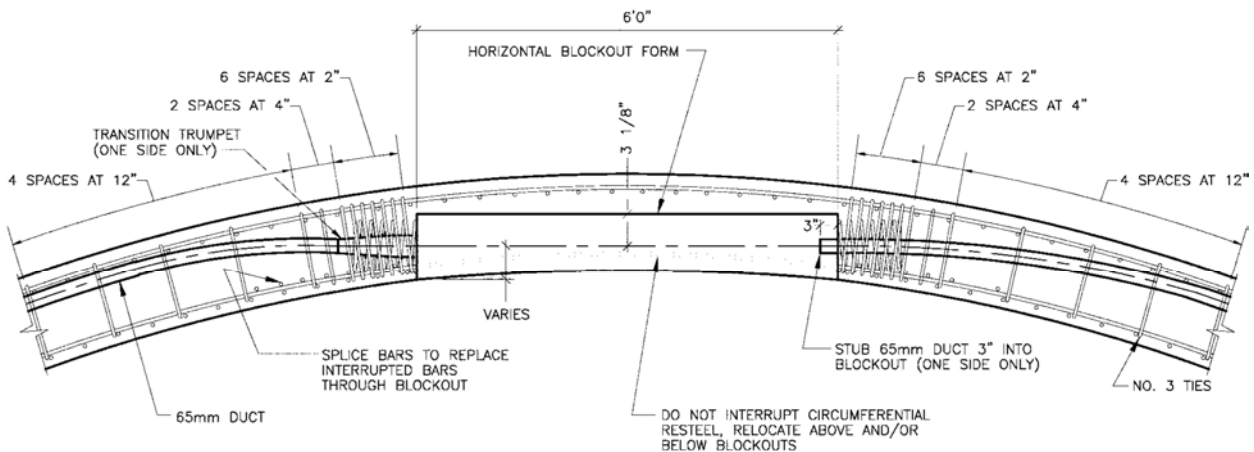

Fig. 5.3—Blockout detail.

rock, or to a depth and extent that provides information to design the foundation. The investigation should be by a licensed design professional. The results of the geotechnical investigation should be detailed in a geotechnical report.

The following information should be provided to the design professional responsible for conducting the geotechnical investigation:

- (a) Tank configuration, including pedestal diameter;
- (b) Gravity loads acting on the foundation: dead, water, and live loads;
- (c) Wind and estimated range of seismic overturning moments and horizontal shear forces acting at the top of foundation;
- (d) Minimum foundation depth for frost penetration or to accommodate piping details; and
- (e) Whether deep foundation units are required to resist tension uplift forces.

6.1.3 Foundation recommendations—The design of foundations should be based on the results of the geotechnical investigation. The foundation should be configured to follow the recommendations of Sections 6.2 through 6.5. Structural components should conform to [Section 5.2.1](#).

6.2—Foundation depth

Foundation depth should be below the extreme frost penetration depth, or as required by the applicable building code. A smaller foundation depth may be used if the foundation overlies material not susceptible to frost action. The minimum depth should be 12 in. (300 mm).

6.3—Settlement limits

The combined foundation and concrete pedestal provide a rigid construction that will experience little or no out-of-plane settlement. The subsurface deformations that require consideration are total settlement, and differential settlement that causes tilting of the structure. Typical long-term limits for settlement under Load Combination S1.1, dead and full water load, are:

- (a) Total settlement for shallow foundations 3 in. (75 mm)
- (b) Total settlement for deep foundations 1 in. (25 mm)
- (c) Tilting of the structure due to nonuniform settlement 1/800

Larger differential tilt is permitted when included in [Eq. \(5-13b\)](#). Maximum tilt should not exceed 1/300.

Elevations for slabs-on-ground, driveways, and sidewalks should be selected to have positive drainage away from the structure after long-term settlements have occurred.

6.4—Shallow foundations

6.4.1 Ultimate bearing capacity—The ultimate bearing capacity q_r is the limiting pressure that may be applied to the soil/rock surface by the foundation without causing a shear failure in the material below the foundation. It should be determined by the application of generally accepted geotechnical and civil engineering principles in conjunction with a geotechnical investigation.

6.4.2 Allowable bearing capacity—The allowable uniform bearing capacity q_a is the limiting service load pressure that may be applied to the soil/rock surface by the foundation. It should be the smaller value determined from:

- (a) Permissible total and differential settlements; and
- (b) Ultimate bearing capacity divided by a safety factor of not less than 3.

The geotechnical report should also define a maximum allowable edge pressure for short-term overturning moment load cases.

6.4.3 Net bearing capacity—Ultimate or allowable bearing pressure should be reported as the net bearing pressure defined in [Fig. 6.1](#).

6.4.4 Foundation size—The size of shallow foundations should be the larger size determined for settlements in accordance with Section 6.3 or the bearing capacity of the soil using the unfactored loads in [Section 5.1.2.2.2](#).

6.5—Deep foundations

6.5.1 Ultimate capacity—The ultimate capacity of piles or piers, Q_r , should be based on a subsurface investigation by a qualified geotechnical design professional, and one of the following:

- (a) Application of generally accepted geotechnical and civil engineering principles to determine the ultimate capacity of the tip in end bearing, and the side friction or adhesion;
- (b) Static load testing in accordance with ASTM D1143/D1143M of actual foundation units;
- (c) Other in-place load tests that measure end bearing and side resistance separately or both; or
- (d) Dynamic testing of driven piles with a pile-driving analyzer.

6.5.2 Allowable capacity—The allowable service load capacity Q_a is the ultimate capacity Q_r divided by a safety factor not less than shown in [Table 6.1](#). It should not be greater than the load causing the maximum permissible settlement. The geotechnical report should also define a maximum allowable pile capacity for short-term overturning moment load cases.

6.5.3 Settlement and group effects—An estimate of the settlement of individual piles or piers, and of the group, should be made by the geotechnical design professional.

6.5.4 Lateral load capacity—The allowable lateral load capacity of piles and drilled piers and corresponding deformation at the top of the pile or pier should be determined by the geotechnical design professional. The subgrade modulus or other soil parameters suitable for structural design of the pile or pier element should be reported.

6.5.5 Number of piles or drilled piers—The number of piles or drilled piers should be the larger number determined for settlement in accordance with Section 6.5.3 or for the resistance of the soil or rock using the unfactored loads in [Section 5.1.2.2.2](#).

6.5.6 Spacing of piles or drilled piers—The minimum spacing between centers of driven piles should not be less than 2.0 times the butt diameter. The following should be considered when determining the spacing and arrangement of piles and drilled piers:

- (a) The overlap of stress between pile or drilled pier units influencing total load capacity and settlement; and
- (b) Installation difficulties, particularly the effects on adjacent piles or drilled piers.

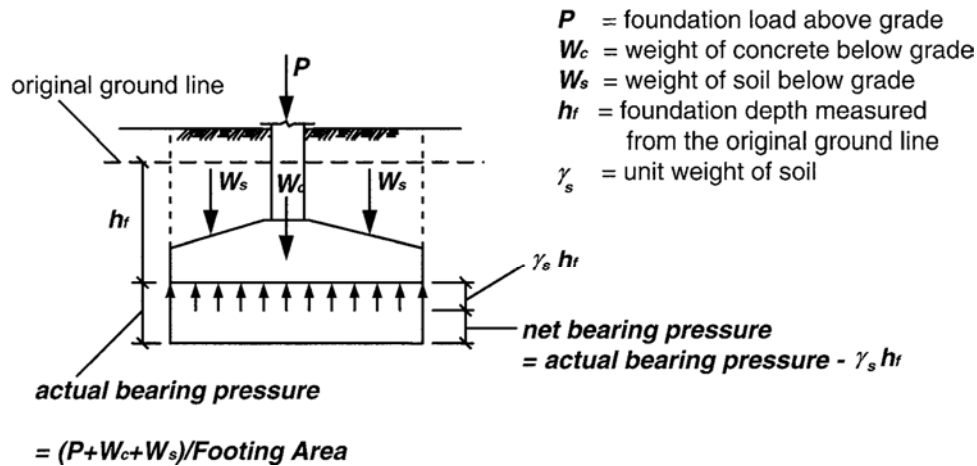

Fig. 6.1—Net bearing pressure.

Table 6.1—Factor of safety for deep foundations

Ultimate capacity in accordance with Section	Recommended minimum safety factor
6.5.1(a)	3.0
6.5.1(b)	2.0
6.5.1(c)	2.0
6.5.1(d)	2.25

6.5.7 Number and arrangement of piles or drilled piers—The numbers and arrangement of piles or piers should be such that the allowable capacity Q_a is not exceeded when the foundation is subjected to the combined service loads defined in Section 5.1.2.2.2.

6.6—Seismic recommendations

Design and detailing of foundations should be in accordance with ASCE/SEI 7-05 Sections 12.13, 14.1.8, and 14.2.3.

6.7—Special considerations

6.7.1 Sloping ground—Where the foundation is on or near sloping ground, the effect on bearing capacity and slope stability should be considered in determining bearing capacity and foundation movements.

6.7.2 Geological conditions—Geological conditions such as karst (sinkhole) topography, faults, or geologic anomalies should be identified and provided for in the design.

6.7.3 Swelling and shrinkage of soils—Where swelling or shrinkage movements from changes in soil moisture content are encountered or known to exist, such movement should be considered.

6.7.4 Expanding or deteriorating rock—Where rock is known to expand or deteriorate when exposed to unfavorable environmental conditions or stress release, the condition should be provided for in the design such as constructing a mud mat directly after the rock has been excavated.

6.7.5 Construction on fill—Acceptable soil types and compaction and inspection requirements should be investigated and specified when foundations are placed on fill.

6.7.6 Groundwater level changes—The effect of temporary or permanent changes in groundwater levels on adjacent property should be investigated and provided for in the design.

CHAPTER 7—APPURTENANCES AND ACCESSORIES

7.1—General

7.1.1 Scope—This chapter describes the appurtenances required for operation and maintenance, and accessories commonly furnished with elevated concrete and composite steel-concrete water storage tanks, as shown in Fig. 7.1 and 7.2. Items furnished at any given installation will depend on the project documents and the applicable building code.

7.1.2 Design—Design and detailing of accessories and appurtenances should conform to the applicable building code, and state and federal requirements where applicable. Loads should not be less than those required by ASCE/SEI 7 or OSHA, as applicable. Dimensions and sizes, where shown, are intended to indicate what is commonly used, and may not conform to codes and regulations in all cases because of differences between codes and regulations, and revision of these documents.

7.1.3 Personnel safety—The design and details of ladders, stairways, platforms, and other climbing devices should conform to OSHA and applicable building code requirements for industrial structures. The design and use of anti-fall devices (cages and safe climb devices) should be compatible with the climbing system to which they attach. Attachment of ladders, stairways, platforms, and anti-fall devices to the structure should be designed to mechanically fasten securely to the structure during the anticipated service life, considering the exposure of the attachment to the environment.

7.1.4 Galvanic corrosion—Dissimilar metals should be electrically isolated to prevent galvanic corrosion.

7.2—Pedestal access

7.2.1 Exterior doors—One or more exterior doors are recommended for access to the pedestal interior and should conform to the following:

- (a) At least one personnel or vehicle door of sufficient size to permit moving the largest equipment or mechanical item through the pedestal wall;
- (b) Steel pipe bollards should be provided at the sides of vehicle door openings for impact protection; and

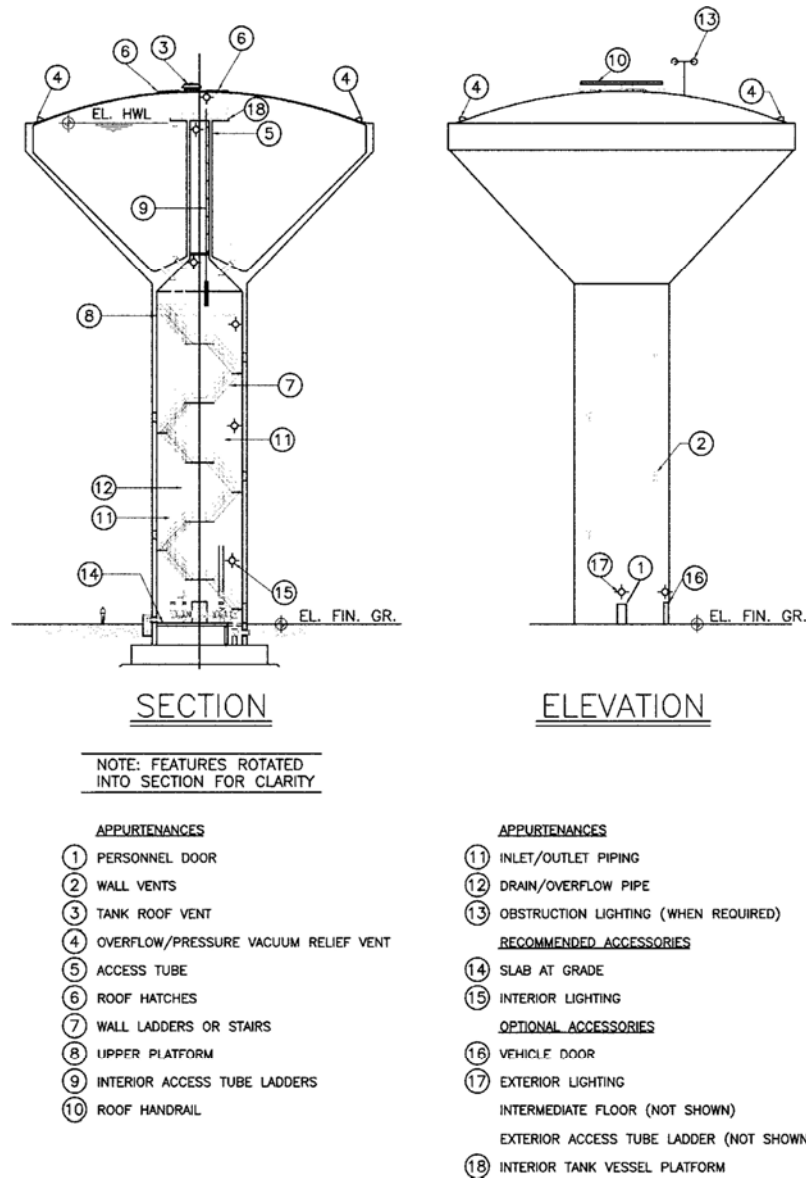

Fig. 7.1—Typical accessories and appurtenances for elevated concrete tanks.

(c) Doors at grade should have locking devices to prevent unauthorized access to ladders and equipment located inside the pedestal.

7.2.2 Exterior access—A hinged or removable door at the top of the pedestal is recommended for access to the outside, for example, for painters rigging from the upper platform on composite tanks. The opening should have a least dimension of 24 in. (600 mm). It may be screened and louvered to satisfy all or part of the vent area requirements.

7.3—Ventilation

7.3.1 Pedestal vents

7.3.1.1 Location and number—The location and number of vents for ventilation of the concrete pedestal interior should conform to state and local building code requirements based on occupancy classification. A removable vent at the top of the pedestal may be used for access to the exterior rigging rails located at the steel vessel/concrete pedestal intersection for elevated composite steel-concrete tanks only.

7.3.1.2 Description—Vents should be stainless steel, aluminum, fiberglass, or brass, and should have removable insect screens.

7.3.1.3 Access—Vents should generally be accessible from the interior ladders, platforms, or floors.

7.3.2 Tank vessel vent

7.3.2.1 Location—The tank vessel vent should be centrally located on the tank roof above the maximum weir crest elevation.

7.3.2.2 Description—The vent consists of a support frame, screened area, and cap. The support should be fastened to an opening in the tank vessel roof. The vent cap should be provided with sufficient overhang to prevent the entrance of wind-driven debris and precipitation. A minimum of 4 in. (100 mm) should be provided between the roof surface and the vent cap. The vent should be provided with an insect screen as required by applicable building codes, health regulations, or project documents.

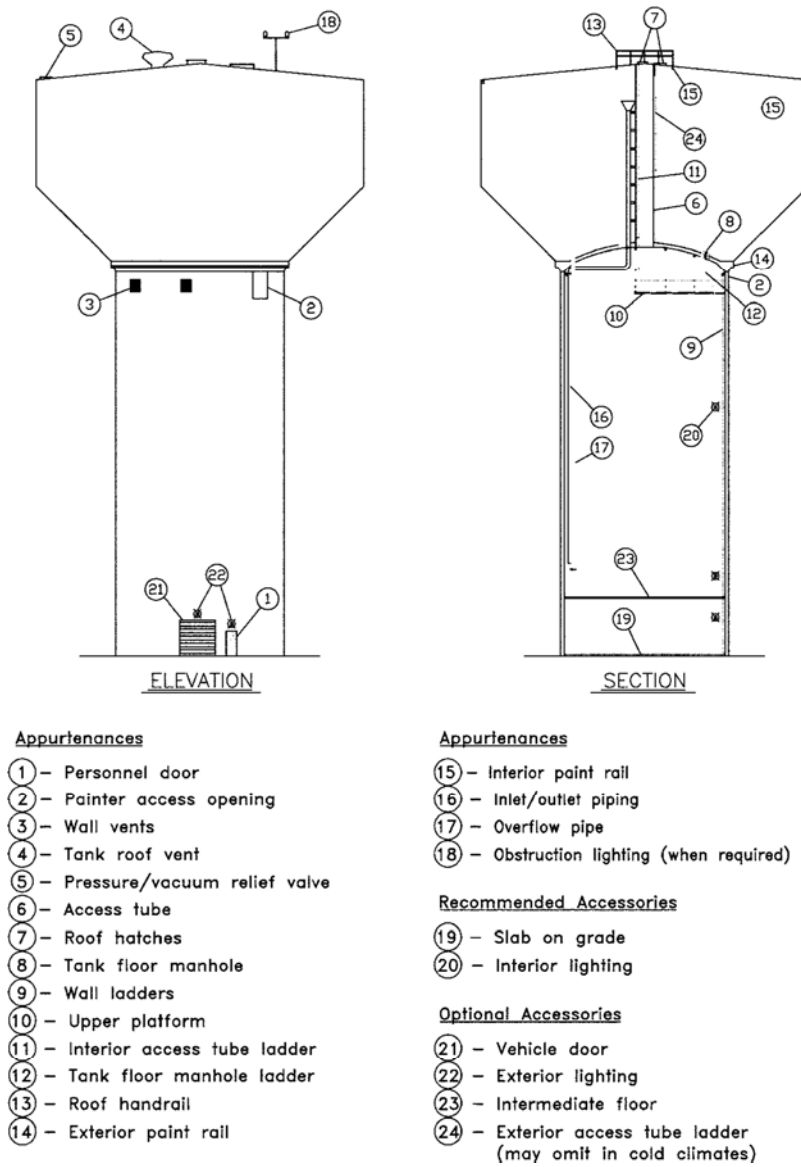

- Appurtenances**
- ① - Personnel door
 - ② - Painter access opening
 - ③ - Wall vents
 - ④ - Tank roof vent
 - ⑤ - Pressure/vacuum relief valve
 - ⑥ - Access tube
 - ⑦ - Roof hatches
 - ⑧ - Tank floor manhole
 - ⑨ - Wall ladders
 - ⑩ - Upper platform
 - ⑪ - Interior access tube ladder
 - ⑫ - Tank floor manhole ladder
 - ⑬ - Roof handrail
 - ⑭ - Exterior paint rail

- Appurtenances**
- ⑮ - Interior paint rail
 - ⑯ - Inlet/outlet piping
 - ⑰ - Overflow pipe
 - ⑱ - Obstruction lighting (when required)
- Recommended Accessories**
- ⑲ - Slab on grade
 - ⑳ - Interior lighting
- Optional Accessories**
- ㉑ - Vehicle door
 - ㉒ - Exterior lighting
 - ㉓ - Intermediate floor
 - ㉔ - Exterior access tube ladder (may omit in cold climates)

Fig. 7.2—Typical accessories and appurtenances for elevated composite steel-concrete tanks.

7.3.2.3 Capacity—The tank vent should have an intake and relief capacity sufficiently large that excessive pressure or vacuum will not develop when filling or emptying the tank at maximum flow rate of water. The maximum flow rate of water exiting the tank should be based on an assumed break in the inlet/outlet at grade when the tank is full. The overflow pipe should not be considered as a vent. Vent capacity should be based on open area of screening used. Vents should be designed to operate when frosted over or otherwise clogged, or adequate pressure/vacuum relief should be provided. These recommendations will be met on elevated concrete tank domes when the open area for a combination vent/external overflows is greater than three times the area of the largest pipe.

7.3.3 Pressure/vacuum relief for elevated composite steel-concrete tanks—A pressure/vacuum relief mechanism should be provided that will operate in the event of tank vent failure for steel vessels only. It should be located on the tank

roof above the maximum weir crest elevation, and may be part of the vent. Design of the pressure/vacuum relief mechanism should be such that it is not damaged during operation, and that it returns to the normal position after relieving the pressure differential.

7.4—Tank access

7.4.1 General—Access from interior of the pedestal to the tank vessel roof and interior is provided by the appurtenances described as follows.

7.4.1.1 Materials—Materials typically used for appurtenances:

- For composite tanks:
- (a) Ladders, stairs, and platforms..... painted or galvanized steel
 - (b) Access tube..... painted steel plate or pipe
 - (c) Roof hatches and covers painted or galvanized steel or aluminum
 - (d) Manholes painted or galvanized steel or stainless steel

(e) Embedments painted or galvanized steel or stainless steel
For concrete tanks:

- (a) Ladders, stairs, and platforms aluminum or concrete
- (b) Access tube concrete or fiberglass
- (c) Roof hatches and covers fiberglass or aluminum
- (d) Manholes ASTM A666-03, Type 316L stainless steel
- (e) Embedments ASTM A666-03, Type 316L stainless steel

7.4.1.2 Attachment to steel vessel—Attachment of ladders and other accessories to the steel vessel should be with brackets welded to the steel vessel. Attachment of the accessory to the brackets may be by welding or bolting. The access tube exterior should be reinforced where ladder brackets are attached so that potential ice damage is confined to the ladder and bracket, and not the access tube shell.

7.4.1.3 Attachment to concrete—The following methods are commonly used for attachment of accessories and appurtenances to concrete:

- (a) Embedded anchor bolts and threaded anchorages;
- (b) Welding or bolting to embedment plates anchored with headed studs; and
- (c) Drilled anchors: expansion type and grouted type using chemical adhesives. Only drilled anchors that can be inspected or tested for proper installation should be used.

7.4.2 Ladders

7.4.2.1 Location—Interior vertical access ladders or stairs should be provided at the following locations:

- (a) Ladders or stairs from the at-grade floor to the upper pedestal platform;
- (b) Upper pedestal platform to a tank floor manhole, if used;
- (c) Ladder mounted on the vessel access shaft or tube interior running from the upper pedestal platform to the tank vessel roof or to the optional platform above the access shaft inside the concrete tank vessel; and

(d) Ladder from the concrete tank vessel interior platform, if used, to the concrete tank vessel dome roof. Otherwise, a ladder from the tank vessel floor to the tank vessel roof mounted on the access shaft or tube exterior. In cold climates, this ladder may be omitted to prevent damage from ice.

7.4.2.2 Ladder details—Configuration, clearances, design, and details of ladders and related safety devices should comply with applicable OSHA requirements.

7.4.3 Platforms and handrails

7.4.3.1 Loads—Platforms and handrails should be designed for the minimum loads defined in Sections 4.2 through 4.4 of ASCE/SEI 7-05, and the requirements of OSHA and the applicable building code.

7.4.3.2 Platforms—Platforms should be provided at the following locations, complete with handrails and toe boards:

(a) An upper platform located below the tank floor that provides access from the pedestal wall ladder or stairs to the access shaft or tube interior ladder. This platform may also provide access to an optional tank vessel floor manhole and the pedestal access opening for painters on elevated composite steel-concrete tanks. A least platform dimension of 3 ft (0.9 m) should be used;

(b) Intermediate platforms are used for access to piping or equipment, as rest or stair platforms, and with offset ladders. A least platform dimension of 3 ft (0.9 m) should be used; and

(c) Inside tank vessel platform above the high water line (optional). A least platform dimension of 5 ft (1.5 m) is recommended.

7.4.3.3 Roof handrail—A handrail surrounding the roof hatches or manholes, vents, and other roof equipment should be provided. Where a handrail is not used or where equipment is located outside the handrail, anchorage devices for the attachment of safety lines should be provided.

7.4.4 Access shaft or tube—The access shaft or tube provides interior access to the tank vessel roof or optional inside tank vessel platform, if used, from the upper pedestal platform, through the water-containing portion of the tank. The access shaft should be not less than 42 in. (1.07 m) inside-diameter, equipped with a hinged hatch cover with inside handle and interior locking device. The hatch opening size should have a least dimension of 24 in. (600 mm).

7.4.5 Concrete tank vessel access openings—Hatch opening(s) should be located in the concrete vessel dome for access to the dome and for operations. Hatch covers should be fiberglass equipped with a hasp to permit locking and should provide a minimum 2 ft 11 in. x 3 ft 8 in. (0.9 x 1.1 m) clear access opening.

7.4.6 Steel vessel roof openings—Steel vessel roof openings should be located above the overflow level at ladder locations. Safety grating, barricades, warning signs, or other protection should be provided at roof openings to prevent entry at locations where ladders are omitted. Hatches should be weatherproof and equipped with a hasp to permit locking. Roof hatch openings should have a least dimension of 24 in. (600 mm).

7.4.7 Steel vessel floor manhole—A manhole in the steel vessel floor should be provided that is accessible from the upper pedestal platform or from a ladder that extends from the upper pedestal platform to the opening. It should have a least dimension of 24 to 30 in. (600 to 750 mm).

7.5—Rigging devices for steel vessel

Bar, tee rails, or other rigging anchorage devices should be provided for painting and maintenance of the steel vessel (OSHA 2008). The safe load capacity for rigging devices should be shown on construction drawings. Access to rigging attachments should be provided.

7.5.1 Exterior rails—A continuous bar or tee rail near the top of the exterior of the concrete pedestal should be provided. The rail may be attached to the concrete pedestal or steel vessel. Access to the rail is from the upper pedestal platform through a painter's opening (Section 7.2.2).

7.5.2 Steel vessel interior—Provision for painting the interior of the steel tank vessel should be provided. Painter's rails attached to the steel vessel roof or pipe couplings with plugs in the steel vessel roof are commonly used for rigging attachments.

7.5.3 Pedestal interior—Rigging attachments should be provided near the top of the pedestal wall for inspection and maintenance of piping and equipment not accessible from platforms or floors.

7.6—Above-ground piping

7.6.1 Materials—Ductile iron, steel, and stainless steel pipe and fittings may be used for above-ground piping.

7.6.1.1 Minimum thickness—For composite tanks:

Steel pipe with a minimum thickness of 1/4 in. (6.4 mm) or Class 53 ductile iron pipe should be used where pipe is exposed to stored water inside the tank. Minimum thickness of pipe or pipe specification located outside the stored water area should be:

- (a) Steel pipe without interior lining or coating1/4 in. (6.4 mm)
- (b) Steel pipe with interior lining or coating3/16 in. (4.8 mm)
- (c) Stainless steel pipe
for overflow piping..... Schedule 5 or 1/8 in. (3 mm) minimum
- (d) Stainless steel
pressurized piping..... Schedule 5 or 3/16 in. (5 mm) minimum
- (e) Ductile iron pipe..... Class 53

For concrete tanks:

Stainless steel pipe with a minimum thickness of 1/4 in. (6.4 mm) or Class 53 ductile iron pipe should be used where pipe is exposed to stored water inside the tank. The minimum thickness of pipe or pipe specification located outside the stored water area should be:

- (a) Stainless steel pipe Schedule 5
- (b) Ductile iron pipe Class 53

7.6.1.2 Interior linings or coatings—Where interior linings or coatings are required, pipe components should be detailed and field assembled so as not to damage the interior lining or coating.

7.6.2 Inlet/outlet pipe

7.6.2.1 Configuration—Usually a single inlet/outlet pipe is used to connect the tank to the system water main. The pipe extends through the vessel floor and runs vertically downward to an expansion joint connected to a base elbow or other piping. Various configurations for piping outside the pedestal to the water system are used that depend on foundation details and climate considerations.

7.6.2.2 Sizing—The minimum diameter of the inlet/outlet pipe is based on acceptable losses due to system flows and consideration of freezing potential.

7.6.2.3 Support—Vertical pipe loads, including axial expansion joint forces, are supported at the tank vessel floor. The weight of water in the pipe is supported by the base elbow or piping below the expansion joint. Pipe guides for horizontal support are attached to the pedestal wall at intervals that should not exceed 20 ft (6 m) without a detailed design.

7.6.2.4 Expansion joints—The expansion joint in the inlet/outlet pipe should be designed and constructed to accommodate any differential movement caused by settlement and thermal expansion and contraction. The required flexibility should be provided by an expansion joint located near grade in the vertical section of pipe.

7.6.2.5 Differential movement—Potential movement between the water main system and tank piping due to settlement or seismic loads should be considered in the design. A mechanical joint or coupling should be provided at the point of connection to the water main system unless no movement is expected. Additional couplings or special fittings may be used if differential movement is expected to be large.

7.6.2.6 Entrance details—A flush-mounted inlet/outlet pipe should have a removable silt stop at or below the design low water level that projects a minimum of 6 in. (150 mm) above the tank vessel floor. Separate inlet and outlet pipes, or some other configuration, may be provided to maximize water circulation. Inlet safety protection should be provided in accordance with applicable safety regulations. Where no permanent protection is required, a safety grate or plate should be provided during construction.

7.6.3 Overflow

7.6.3.1 Configuration—The top of the overflow should be located within the tank vessel at the level required by the project documents and should run approximately as shown in Fig. 7.1 and 7.2. The discharge should be designed such that it will not be obstructed by snow or other objects. The horizontal run of pipe below the tank vessel floor should be sloped for positive drainage.

7.6.3.2 Sizing—The overflow pipe should be sized to carry the maximum design flow rate of the inlet pipe. Head losses from pipe, fittings, and exit velocity should be considered in determining pipe diameter. The overflow pipe should not be less than 4 in. (100 mm) diameter.

7.6.3.3 Entrance—The entrance to the overflow pipe should be designed for the maximum inlet pipe flow rate. Typical design is based on the water level cresting above the overflow level no more than 3 in. (75 mm) for concrete tanks, and 6 in. (150 mm) for steel tanks. A suitable weir should be provided when the entrance capacity of the overflow pipe is not adequate.

7.6.3.4 Support—Supports for the overflow pipe should be designed for static, dynamic, and thermal loads. Support brackets, guides, and hangers should be provided at intervals that do not exceed 20 ft (6 m) without a detailed design. The overflow and weir section within the steel vessel may be attached to the access shaft or tube for support.

7.6.3.5 Discharge—The overflow pipe should discharge onto a splash block at grade, or into a sump or a drain line, that effectively removes water away from the foundation. The end of the overflow pipe should be covered with a coarse, corrosion-resistant mesh or a flap valve.

7.6.4 Tank drain—An inlet/outlet pipe or a separate drain line that is near the low point of the tank vessel should be provided to drain the tank vessel.

7.7—Below-ground piping

7.7.1 Pipe cover—Pipe cover should be greater than the extreme frost penetration, or as required by the applicable building code. The minimum cover should be 24 in. (600 mm).

7.7.2 Differential movement—Connecting piping and utilities should have sufficient flexibility to accommodate twice the predicted settlement or movement due to seismic loads without damage.

7.8—Interior floors within pedestal

7.8.1 General—A concrete slab-on-ground should be provided inside the concrete pedestal. One or more intermediate floors above grade may be furnished when provided for in the original design.

Table 7.1—Minimum recommendations for slabs-on-ground

Description	Door opening width less than 8 ft (2.4 m)	Door opening width greater than 8 ft (2.4 m)
Concrete strength f'_c	3500 psi (24 MPa)	4000 psi (28 MPa)
Thickness	5 in. (125 mm)	6 in. (150 mm)
Reinforcement ratio	0.0018	0.0018

Note: Floor intended to be used for parking of heavy vehicles or similar loads should be designed for the specific loading anticipated.

7.8.1.1 Occupancy classifications—Each portion of the interior space should be classified according to its use or the character of its occupancy and the requirements of the applicable building code for the type of occupancy should be met.

7.8.1.2 Posted live loads—The safe floor live loads should be displayed on a permanent placard in a conspicuous location at each floor level.

7.8.2 Slabs-on-ground—Refer to ACI 302.1R for guidance on floor slab construction, and ACI 360R for recommended design requirements.

7.8.2.1 Minimum recommendations—Slabs-on-ground are usually designed as plain concrete slabs where reinforcement and joint spacing are used to control cracking and to prevent cracks from opening. Where project documents do not indicate how the slab-on-ground will be used, the values in Table 7.1 are recommended.

7.8.2.2 Details of reinforcement—Reinforcement should be located approximately 2 in. (50 mm) below the top surface of the slab. Slabs greater than 8 in. (200 mm) thick should have two layers of reinforcement. Either welded wire reinforcement or deformed bar reinforcement may be used. Maximum spacing of wires or bars should not be greater than 18 in. (450 mm). Reinforcement should be maintained in correct position by support chairs or concrete masonry units. Additional reinforcement should be provided at floor edges and other discontinuities, as required by the design.

7.8.2.3 Joints—The following joint types are commonly used and should conform to ACI 504R:

(a) *Isolation joints*. The floor slab should be separated structurally from the concrete pedestal to accommodate differential horizontal and vertical movements. The floor slab may also be structurally isolated from other elements of the structure, such as sumps, unless a monolithic design is performed. Isolation joints should be provided at junctions with pedestal walls and possibly other points of restraint. Isolation joints should be formed by setting expansion joint material before concrete placement. The joint filler should extend the full depth of the joint and not protrude above the surface; and

(b) *Contraction joints*. Joint spacing should be at 20 ft (6 m) maximum centers unless a higher percentage of steel reinforcement than recommended by Table 7.1 is used. All joint spacing should meet the recommendations of ACI 302.1R.

7.8.2.4 Drainage—The surface of slabs-on-ground should have a minimum slope of 1% sloping to drains. Where drains are not provided, slabs-on-ground should be sloped to doorways.

7.8.2.5 Subgrade—The suitability of in-place and fill soils for supporting the slab-on-ground should be determined

by the geotechnical design professional. Unsuitable soils should be improved or replaced. Compaction of fill and backfill material should comply with Table 4.1. Where expansive soils are encountered, the recommendations of the geotechnical design professional should be followed.

7.8.2.6 Structural floors—An isolated structural floor slab near grade may be required where compressible or expansive soils are encountered. Design of structural floors should conform to ACI 318.

7.8.3 Intermediate floors—One or more floors above grade may be constructed for storage or other uses. Typically the structural system is a concrete flat slab, or a beam and slab system attached to the concrete pedestal, and may include intermediate columns.

7.8.3.1 Loads—Loads should conform to the applicable building code, based on occupancy classification. Floors used for storage should be designed for a minimum uniform live load of 125 lb/ft² (6 kPa). The minimum design live load should be 50 lb/ft² (2.4 kPa).

7.8.3.2 Design and construction—Dead and live loads from any intermediate floors should be accounted for in the design of the concrete pedestal and foundation. Localized axial loads, moments, and shears due to beam end reactions should be considered in the design of the pedestal.

7.9—Electrical and lighting

7.9.1 General—Electrical work should conform to the governing applicable building code and other applicable regulations.

7.9.2 Lighting and receptacles

7.9.2.1 Exterior—A single light should be provided above each personnel and vehicle door. These lights should be controlled by a single switch located on the interior of the pedestal, adjacent to the open side of the personnel door.

7.9.2.2 Interior—Interior lighting and receptacles should be provided at the following locations:

(a) *Base*. Lights should be provided 8 ft (2.4 m) above the slab-on-ground at equal intervals not exceeding 30 ft (9 m) along the pedestal wall. These lights should be controlled by a single switch located adjacent to the open side of the access door. One convenience outlet should be provided adjacent to the power distribution panel; and

(b) *Ladder/landing*. Lights should be provided adjacent to the pedestal access ladder or stairs at intervals not exceeding 25 ft (8 m). The lower light should be at 8 ft (2.4 m) above the slab and the top ladder or stair light should be placed above the upper platform. A light should be provided 8 ft (2.4 m) above each intermediate platform. Lights should be provided at the top and bottom of the interior access shaft or tube. These lights should be controlled by a single switch located at the base of the pedestal access ladder or stairs.

7.9.2.3 Obstruction lighting—Obstruction lighting and marking requirements depend on structure height and proximity to air traffic. The Federal Aviation Agency (FAA) should be contacted to determine if obstruction lighting is required. Obstruction lighting should be of weather-tight, corrosion-resistant construction, conforming to FAA standards.

CHAPTER 8—REFERENCES**8.1—Referenced standards and reports**

Unless a specific version is indicated in the document, the standards and reports listed below were the latest editions at the time this document was prepared. Because these documents are revised frequently, the reader is advised to contact the proper sponsoring group if it is desired to refer to the latest version.

American Concrete Institute

- 117 Specifications for Tolerances for Concrete Construction and Materials
- 201.2R Guide to Durable Concrete
- 209R Prediction of Creep, Shrinkage, and Temperature Effects in Concrete Structures
- 211.1 Standard Practice for Selecting Proportions for Normal, Heavyweight, and Mass Concrete
- 212.3R Chemical Admixtures for Concrete
- 212.4R Guide for the Use of High-Range Water-Reducing Admixtures (Superplasticizers) in Concrete
- 224.2R Cracking of Concrete Members in Direct Tension
- 301 Specifications for Structural Concrete
- 302.1R Guide for Concrete Floor and Slab Construction
- 303R Guide to Cast-in-Place Architectural Concrete Practice
- 304R Guide for Measuring, Mixing, Transporting, and Placing Concrete
- 305.1 Specification for Hot Weather Concreting
- 306.1 Standard Specification for Cold Weather Concreting
- 307 Design and Construction of Reinforced Concrete Chimneys
- 308.1 Standard Specification for Curing Concrete
- 309R Guide for Consolidation of Concrete
- 315 Details and Detailing of Concrete Reinforcement
- 318 Building Code Requirements for Structural Concrete
- 334.2R Reinforced Concrete Cooling Tower Shells—Practice and Commentary
- 336.3R Design and Construction of Drilled Piers
- 347 Guide to Formwork for Concrete
- 350 Code Requirements for Environmental Engineering Concrete Structures
- 350.3 Seismic Design of Liquid-Containing Concrete Structures
- 360R Design of Slabs-on-Ground
- 372R Design and Construction of Circular Wire- and Strand-Wrapped Prestressed Concrete Structures
- 373R Design and Construction of Circular Prestressed Concrete Structures with Circumferential Tendons
- 503.2 Standard Specification for Bonding Plastic Concrete to Hardened Concrete with a Multi-Component Epoxy Adhesive
- 504R Guide to Sealing Joints in Concrete Structures
- 506R Guide to Shotcrete

American Society of Civil Engineers (ASCE)

- ASCE/SEI 7 Minimum Design Loads for Buildings and Other Structures

ASTM International

- A185/A185M Specification for Steel Welded Wire Reinforcement, Plain, for Concrete
- A497/A497M Specification for Steel Welded Wire Reinforcement, Deformed, for Concrete
- A615/A615M Specification for Deformed and Plain Carbon-Steel Bars for Concrete Reinforcement
- A666 Specification for Annealed or Cold-Worked Austenitic Stainless Steel Sheet, Strip, Plate, and Flat Bar
- A706/A706M Specification for Low-Alloy Steel Deformed and Plain Bars for Concrete Reinforcement
- C94/C94M Specification for Ready-Mixed Concrete
- C309 Specification for Liquid Membrane-Forming Compounds for Curing Concrete
- C803/C803M Test Method for Penetration Resistance of Hardened Concrete
- C881/C881M Specification for Epoxy-Resin-Base Bonding Systems for Concrete
- C882 Test Method for Bond Strength of Epoxy-Resin Systems Used with Concrete by Slant Shear
- C900 Test Method for Pullout Strength of Hardened Concrete
- C1074 Practice for Estimating Concrete Strength by the Maturity Method
- D698 Test Methods for Laboratory Compaction Characteristics of Soil Using Standard Effort (12,400 ft-lbf/ft³ (600 kN-m/m³))
- D1143/D1143M Test Methods for Deep Foundations Under Static Axial Compressive Load
- D1557 Test Methods for Laboratory Compaction Characteristics of Soil Using Modified Effort (56,000 ft-lbf/ft³ (2,700 kN-m/m³))

American Water Works Association (AWWA)

- D100 Welded Steel Tanks for Water Storage

American Welding Society (AWS)

- D1.4 Structural Welding Code—Reinforcing Steel

International Code Council

- 1997 UBC Uniform Building Code

The above publications may be obtained from the following organizations:

American Concrete Institute
P.O. Box 9094
Farmington Hills, MI 48333-9094
www.concrete.org

American Society of Civil Engineers
1801 Alexander Bell Dr.
Reston, VA 20191-4400
www.asce.org

ASTM International
100 Barr Harbor Dr.
West Conshohocken, PA 19428-2959
www.astm.org

American Water Works Association
6666 West Quincy Ave.
Denver, CO 80235
www.awwa.org

American Welding Society
550 N.W. LeJeune Rd.
Miami, FL 33126
www.aws.org

International Code Council
500 New Jersey Ave., NW, 6th Floor
Washington, DC 20001-2070
www.iccsafe.org

8.2—Cited references

American Association of State Highway and Transportation Officials (AASHTO), 2002, “Standard Specifications for Highway Bridges,” AASHTO, Washington, DC, 1028 pp.

American Concrete Institute, 2008, “ACI Concrete Terminology,” American Concrete Institute, Farmington Hills, MI, <http://terminology.concrete.org> (accessed June 23, 2008).

Building Seismic Safety Council, 1994, “NEHRP Recommended Provisions for Seismic Regulations for New Buildings: Part 2—Commentary,” Building Seismic Safety Council, Washington, DC.

Meller, E., and Bushnell, D., 1982, “Buckling of Steel Containment Shells. Task 2: Elastic-Plastic Collapse of Nonuniformly Axially Compressed Ring-Stiffened Cylindrical Shells with Reinforced Openings,” *Report LMSC-D812950-VOL-2*, Nuclear Regulatory Commission, Office of Nuclear Reactor Regulation, Washington, DC, Dec., 125 pp.

OSHA, 2008, “Regulations for General Industry: Fixed Ladders,” 29 CFR, Part 1910.27, Occupational Safety and Health Administration, Washington, DC, http://edocket.access.gpo.gov/cfr_2007/julqtr/pdf/29cfr1910.27.pdf (accessed June 23, 2008).

Post-Tensioning Institute, 2006, *Post-Tensioning Manual*, 6th Edition, PTI, Phoenix, AZ, 368 pp.

APPENDIX A—SUPPLEMENTARY INFORMATION

PREFACE TO APPENDIX A

Appendix A is included with ACI 371R for the following reasons. Appendix A contains lengthy derivations of equations for shear distribution and the stability of the pedestal that, if included in the body of the report, would disrupt its flow. These derivations, however, may be of interest to the first-time user of ACI 371R. Also included in Appendix A are explanations and background for many of the recommendations in ACI 371R. Finally, the current practice of design and construction of elevated tanks supported on concrete pedestals supplements several sections of the report.

The “A” designations of sections of Appendix A correspond to section numbers in ACI 371R.

CHAPTER A1—GENERAL

A1.1—Introduction

Since the 1970s, concrete-pedestal elevated water storage tanks have been constructed in North America with a steel water-containing element and an all-concrete support structure. The generic term “composite elevated tank” is often used to describe tanks of this configuration. A few all-concrete elevated tanks have been built in the United States throughout the last century as well as a couple of elevated prestressed tanks jacked into place. Elevated post-tensioned tanks as detailed in this report have a long history in Europe, and were introduced into the United States market in the 1990s.

All-concrete and composite steel-concrete elevated tanks are competitively marketed as complete entities including design, and are constructed under design-build contracts using proprietary designs, details, and methods of construction. The designs, however, are frequently reviewed by owners and their consulting engineers, or by city or county officials.

Elevated tanks designed and constructed in accordance with the recommendations of this guide can be expected to be durable structures that require only routine maintenance. Details of concrete surfaces that promote good drainage and avoid low areas conducive to ponding essentially eliminate the problems associated with cyclic freezing and thawing of wet concrete in cold climates. The quality of concrete for elevated tanks in this document meets the requirements for durable concrete as defined in ACI 201.2R. It has adequate strength, a low water-cementitious material ratio (w/cm), and air entrainment for frost exposure. The concrete support structure loads are primarily compression with little or no cyclic loading with stress reversal.

A1.2—Scope

This document considers elevated water storage tanks of the types shown in Fig. 1.1 and 1.2 of ACI 371R. It addresses specific design and construction issues unique to these tank configurations.

CHAPTER A2—NOTATION AND DEFINITIONS

A2.2—Definitions

Terminology in this document is consistent with the definitions in “ACI Concrete Terminology” (American Concrete Institute 2008). Because the term used in the industry for the concrete cylindrical support wall supporting the tank vessel is a concrete-pedestal, the term “pedestal,” as used in this document, may deviate somewhat from the strict definition of “ACI Concrete Terminology.”

CHAPTER A3—MATERIALS

A3.1—Materials common to both composite and concrete tank types

The provisions of this section are intended to address requirements specific to the elevated tanks that may limit or supplement ACI 318 and 350.

CHAPTER A4—CONSTRUCTION

A4.1—Construction common to both composite and concrete tank types

A4.1.1 General

A4.1.1.1 Reference standards—The structural concrete construction provisions of this guide emphasize the construction requirements unique to elevated tanks, and should conform to ACI 318 and 350 except as modified. ACI 301 is recommended for use in preparing project specifications.

A4.1.1.2 Quality assurance—Quality assurance requirements are defined, and are considered good practice. The requirements conform to ASCE/SEI 7-05, Appendix 11A. The design professional is also responsible for the quality assurance plan necessary to verify that design requirements have been met. The use of certified personnel and accredited laboratories is considered good practice. The contractor is responsible for establishing procedures for controlling the work.

A4.1.2 Concrete

A4.1.2.2 Concrete quality—The quality of concrete is intended to provide durable concrete in all climates.

A4.1.2.3 Proportioning—Concrete should be proportioned only on the basis of field experience or trial mixtures. For concrete exposed to view, the same brand and type of materials should be used to maintain uniformity of color.

A4.1.2.3.2 Slump—A 4 in. (100 mm) slump concrete has a tolerance range of 3 to 5 in. (75 to 125 mm). A minimum 4 in. (100 mm) slump or the use of a high-range water-reducing admixture (HRWRA) is recommended for the pedestal and any concrete with closely spaced reinforcement. Concrete with HRWRAs is typically proportioned to produce a slump of 4 in. (100 mm) before addition of the HRWRA. Concrete with a slump of less than 3 in. (75 mm) may be required for the inclined surfaces.

A4.1.2.3.3 Admixtures—Admixtures are important components of a concrete mixture that may provide beneficial modifications to concrete properties. Admixtures may affect more than one property of concrete, sometimes adversely affecting desirable properties. Manufacturer's instructions and limitations should be followed, and it is recommended that the effects of admixtures be evaluated through testing with representative materials and placement conditions before use in the structure. ACI 212.3R and 212.4R provide guidance for using chemical admixtures and HRWRAs.

A4.1.2.4 Concrete production

A4.1.2.4.1 Slump adjustment—HRWRAs can be added at the batch plant or the site. Short transit times and the ability to produce concrete with a consistent slump lend themselves to batch-plant dispensing of HRWRAs. Long transit times and site personnel experienced in using HRWRAs lend themselves to site dispensing of the admixture.

A4.1.2.5 Placement—Contingency plans should be prepared to handle breakdown of equipment during concrete placement. At least one spare vibrator should be kept on the site during concrete placement operations. Concrete should be placed in such a manner as to avoid cold joints in the structural element being placed. Retarders should be used when required to prevent cold joints.

A4.1.2.6 Curing—Curing compounds are almost always used for this type of structure. Where subsequent coatings are to be applied to the concrete, the curing compound should be compatible with the coatings or the material should be removed before application of the coatings.

A4.1.2.7 Weather

A4.1.2.7.2 Cold weather—Insulated formwork is commonly used for protection of the pedestal concrete during cold weather.

A4.1.2.8 Testing, evaluation, and acceptance—When concrete fails to meet the acceptance criteria of ACI 318 or 350, structural analysis, additional testing, or both, should be performed to determine if the component is structurally adequate.

A4.1.2.8.1 Concrete strength tests—Concrete placement can occur as often as once a day; at 28 days, most concrete is under subsequent placements that would have to be demolished if the lower concrete was found to be deficient and had to be replaced. To gain some assurance that the 28-day tests will meet the strength requirements, extra cylinders are usually made to provide an early-age strength that can be used to estimate 28-day strength.

A4.1.2.9 Joints and embedments

A4.1.2.9.1 Construction joints—Construction joints are typically limited to horizontal joints in the pedestal. Bonding agents and formed keyways are not normally used for horizontal construction joints in the pedestal. Vertical construction joints are not normally used because of the relatively small form area required to form a lift.

A4.1.3 Formwork

A4.1.3.1 General—ACI 347 provides detailed information on formwork design, construction, and materials. The design of the formwork system for the concrete of elevated tanks must incorporate safety features required by state and federal safety standards.

A4.1.3.1.1 Facing material—The forms for elevated tanks are typically re-used many times, and a durable facing material is required to maintain uniformity of the surface.

A4.1.3.2 Foundations

A4.1.3.2.3 Removal—Side forms are typically removed the day following concrete placement. Where adequate protection from cold weather is provided, an elapsed time of 12 hours will generally provide concrete strength significantly in excess of that required for safe form removal.

A4.1.3.3 Pedestal

A4.1.3.3.1 Wall form—The pedestal is subjected to large compressive forces and generally requires a high degree of accuracy with regard to shell tolerance. Properly designed jump forms with through-ties can routinely achieve the required tolerances. Vertical alignment should be controlled with laser equipment. Wall forms should be designed for the full concrete head to avoid overloading and excessive deflection that can occur when forms designed for less than the full head are accidentally overfilled.

A4.1.3.3.2 Deflection—The form deflection limits are specified in ACI 303R for concrete exposed to view.

A4.1.3.3.3 Rustications—A uniform pattern of horizontal and vertical rustications visually breaks up the surface of

the pedestal and makes variations in surface color and texture less noticeable. Horizontal rustications provide shadow lines that make construction joint offsets less noticeable.

A4.1.3.3.5 Removal—Forms are typically removed the following day, provided that the concrete has sufficient strength to permit form removal without damage to the concrete. A minimum concrete compressive strength of 800 psi (5.5 MPa) is generally adequate to prevent damage to concrete surfaces during wall form removal. Where supports or embedments are attached to the concrete for moving forms or other construction activities, the supports or embedments should not be used until the concrete has gained sufficient strength for their safe use.

A4.1.4 Reinforcement—ACI 315 provides guidance for detailing reinforcement.

A4.1.5 Concrete finishes

A4.1.5.2 Formed surfaces—A smooth as-cast finish combined with a uniform rustication pattern results in a pleasing concrete surface and is used for the majority of installations. Special form finishes should be limited to light sandblasting to enhance color uniformity. Rubbed and floated finishes are labor-intensive, and are normally not used.

A4.1.5.3 Trowel finishes—Troweled finishes are defined in ACI 301.

A4.1.6 Tolerances—Tolerances for components of elevated tanks are based on the combined requirements of strength, construction technique, economic feasibility, and aesthetics.

A4.1.7 Foundations

A4.1.7.2 Earthwork

A4.1.7.2.1 Excavations—Excavations for shallow foundations should be inspected to ensure that the proper bearing stratum has been reached, and that conditions are consistent with the findings of the geotechnical investigation. The inspection should be by a qualified design professional familiar with the geotechnical report and the design requirements.

A4.1.7.3 Field inspection of deep foundations—Field inspection requirements are defined, and are considered good practice. These requirements conform to ASCE/SEI 7.

CHAPTER A5—DESIGN

A5.1—Design requirements common to both composite and concrete tank types

A5.1.2 Loads

A5.1.2.1 General—ASCE/SEI 7 minimum design loads are adapted to elevated water storage tanks. The loads are for Structure Classification Category IV defined in Table 1-1 of ASCE/SEI 7-05. The Category IV classification includes structures designated as essential facilities required in emergencies. The structure is considered an essential facility where the stored water is required for fire protection or in an emergency.

A5.1.2.2.1 Factored load combinations—Load combinations are divided into two groups based on whether they add to the effect of dead and water loads (Group 1), or whether they counteract the dead and water loads (Group 2). Load combinations are further divided into those required by ACI 350 for structure components in contact with stored water and those required by ACI 318 for structure components not in contact with the stored water.

Water has the characteristics of a dead load as well as a live load. It is like a dead load in that its magnitude is well defined, and like a live load in that the load is not necessarily permanent and may be applied repeatedly during the life of the structure. To account for the latter effect, ACI 350 requires the load factor for water to be 1.6. This factor results in stresses at service load levels that have given good performance of structures for storing water. The load factor on water for structure components not in contact with stored water is 1.4 in accordance with ACI 318.

A5.1.2.2.1.1.2 Group 2 load combinations—where *D* or *F* reduce effect of *W* or *E*—The load factor on water in U2.1 is 1.0 rather than 0.9, because if the entire mass of the water is accelerated laterally in an earthquake, then the entire mass of the water also resists the seismic overturning moment.

A5.1.2.2.2 Nominal load combinations—Unfactored service load combinations are presented in a form comparable to factored loads. Load Combination S1.1 is the basic long-term load combination used to check serviceability requirements such as concrete cracking and foundation settlement. The structural effects *T* of differential settlement, creep, shrinkage, or temperature effects are usually not significant and are not included in the load combinations.

A5.1.2.6 Wind load—The wind forces considered herein are for rigid structures. The potential for across-wind excitation or flutter should be investigated for tall slender tanks with fundamental periods of 1 second or greater.

A5.1.2.6.2 Wind force—The values of lateral pressure p_z given in Table 5.1 are based on

$$p_z = 0.00256GK_zC_fV_b^2 \text{ (lb/ft}^2\text{)}$$

where

- G = gust factor based on ASCE/SEI 7-05, Section 6.5.8;
 - = 0.85 for structure period T_f of 1.0 second or less;
 - = 1.0 for structure period T_f greater than 1.0 second;
- I = 1.15, importance factor; based on ASCE/SEI 7-05, Table 6-1;
- K_z = exposure coefficient; ASCE/SEI 7-05, Table 6-3, Case 2, for exposure categories defined in ASCE/SEI 7-05, Section 6.5.6.3; and
- V_b = basic wind speed, ASCE/SEI 7-05, Section 6.5.4, Fig. 6-1;
 - = 90 mph (40 m/s).

Force coefficient C_f is

$$C_f = 0.5 + (h/d_w - 1)60 \quad 0.5 \leq C_f \leq 0.6$$

where

- h/d_w = height-diameter ratio. Height h should not be less than height from grade to the top of vessel shell. Diameter d_w should be taken as the maximum vessel diameter or, more precisely, as weighted average of the vessel and shaft diameters with height.

The equation for wind force drag coefficient herein and in Footnote ‡ of Table 5.1 is derived from ASCE/SEI 7-05 Fig. 6-21 for moderately smooth, round cross sections with

$D\sqrt{q_z} > 2.5$, and having height-maximum-diameter ratios in the range of 1 to 7. The value of C_f will vary between 0.5 and 0.6. These are similar to the discrete wind drag coefficient values of 0.5 and 0.6 found in AWWA D100 for doubly curved and cylindrical surfaces, respectively.

The equation form of exposure coefficient K_z is

$$K_z = 2.01(z/z_g)^{2/\alpha} \quad \text{for } z_{15} \leq z \leq z_g$$

$$K_z = 2.01(z_{15}/z_g)^{2/\alpha} \quad \text{for } z < z_{15}$$

where $z_{15} = 15$ ft (4.6 m), and values of α and z_g are as listed in Table A5.1 (ASCE/SEI 7-05 Table 6-2).

A5.1.2.7.2.1 Balanced roof snow load—Equation (5-2a) for roofs with roof slope less than or equal to 45 degrees is based on an importance factor, $I = 1.2$, for Category IV structures in accordance with ASCE/SEI 7-05, Table 7-4, a thermal factor $C_t = 1.2$ for cold roofs in accordance with ASCE/SEI 7-05, Table 7-3, and a roof slope factor $C_{es} = 1.0$ from ASCE/SEI 7-05, Fig. 7-2. Equation (5-2b) for roofs with a roof slope greater than 45 degrees, but not exceeding 70 degrees, is derived from Eq. (5-2a), and ASCE/SEI 7-05, Fig. 7-2, for cold roofs with $C_t = 1.2$.

A5.1.2.8 Earthquake load—The minimum seismic forces prescribed in this document are factored loads intended to be used with the strength design load combinations of Section 5.1.2.2.1.

Elevated tanks covered by this document behave basically as single-degree-of-freedom systems that respond primarily to the fundamental frequency of vibration, and may not need sophisticated analysis techniques for determining seismic forces.

Alternative procedures that may be used for analysis include:

- Modal analysis using solution to the equations of motion;
- Modal analysis using the response spectrum technique; and
- Finite element analysis using modal analysis or the direct integration method.

A5.1.2.8.1 Procedure for determining design earthquake ground acceleration and response spectra—The procedure for determining design earthquake ground acceleration and response spectra follows ASCE/SEI 7 except for the last item in the procedure. The recommendation of Item 6 of the procedure to include consideration of vertical acceleration in the design follows the “Uniform Building Code (UBC).” The UBC requires that the vertical response spectrum be taken as 2/3 of the horizontal acceleration spectrum. The 2/3 provision for vertical acceleration has also been included in some job specifications.

A5.1.2.8.2.1.3 Seismic response coefficient—The response modification coefficient R is in accordance with ASCE/SEI 7-05, Table 15.4-2, for nonbuilding structures not similar to buildings.

A5.1.2.8.2.1.5 Period determination—The fundamental period of vibration T_f should be determined using established methods of mechanics, assuming the pedestal remains elastic during vibration. The following formula

Table A5.1—Values of α and z_g

Exposure category	α	z_g , ft (m)
B	7.0	1200 (370)
C	9.5	900 (270)
D	11.5	700 (210)

based on Rayleigh’s method (Building Seismic Safety Council 1994) is commonly used

$$T_f = 2\pi \sqrt{\frac{\sum(w_i \delta_i^2)}{g \sum(F_i \delta_i)}} \quad (\text{A5-1a})$$

where δ_i = static elastic deflection of the structure at level i due to forces F_i .

Alternatively, a single mass approximation assuming a cantilever of uniform stiffness and the effective structure mass located at the centroid of the stored water may be used to approximate the period of vibration. The structure lateral stiffness k_c is determined from the deflection of the pedestal acting as a cantilever beam of length c_g subjected to a concentrated end load. The flexural stiffness for this condition is

$$k_c = \frac{3E_c I_c}{c_g} \quad (\text{A5-1b})$$

The modulus of elasticity of concrete, E_c , is determined in accordance with ACI 318, and I_c is the moment of inertia of the gross concrete section about the centroidal axis, neglecting reinforcement. The use of uncracked section properties to determine stiffness is consistent with ASCE/SEI 7 where nonlinear seismic coefficients are used with the elastic structure response.

The fundamental period of vibration, T_f , in Eq. (A5-1a) may be approximated by the following equation when a single lumped mass W_l is used to represent the mass of the water and the participating dead load. This is a reasonable approximation for an elevated water tank where the water weight is concentrated near the top of the structure and accounts for the largest portion of the total load.

$$T_f = 2\pi \sqrt{\frac{W_l}{g k_c}} \quad (\text{A5-1c})$$

The cross-sectional area of a thin cylinder of thickness, h_r , is $A_c = \pi d_w h_r$, and its moment of inertia is $I_c = 0.125\pi(d_w)^3 h_r = 0.125A_c(d_w)^2$. Substituting for I_c in Eq. (A5-1b) and then into Eq. (A5-1c) results in the following approximation for fundamental period T_f

$$T_f = 2\pi \sqrt{\frac{8W_l L_g^3}{3A_c E_c d_w^2 g}} \quad (\text{A5-1d})$$

A simple formula to approximate the fundamental period is useful for preliminary design, and provides a means of checking that unrealistically large values of the fundamental period T_f are not used for final design. Substituting the average concrete compression stress f_{ca} for the term (W_1/A_c) in Eq. (A5-1d) and rearranging gives Eq. (A5-1e) for the approximate fundamental period T_a . The average concrete compression stress f_{ca} can be considered the average concrete stress under dead-plus-water loads at the base of the pedestal

$$T_a = \frac{10.26L_g}{d_w} \sqrt{\frac{f_{ca}L_g}{E_c g}} \quad (\text{A5-1e})$$

A further simplification for composite tanks with average compressive stress in the pedestal between 800 and 1000 psi (5.5 to 6.9 MPa) is

$$T_a = \frac{0.16L_{ga}}{d_w} \sqrt{\frac{L_{ga}}{g}} \quad (\text{A5-1f})$$

Terms d_w , E_c , f_{ca} , g , L_g , and L_{ga} are in consistent units.

The term (f_{ca}/E_c) in Eq. (A5-1e) represents the concrete compressive strain that will be in the range of 200 to 300 microstrain for composite tanks. Substituting 250×10^{-6} for (f_{ca}/E_c) , and L_{ga} for L_g results in the simplified Eq. (A5-1f). Height L_{ga} is the approximate height from base to centroid of the stored water. It can be considered as the distance from the base to TCL minus one-half the operating head range.

A5.1.2.8.2.1.6 Vertical distribution of seismic forces—Equation (5-6b) is the seismic force distribution prescribed in ASCE/SEI 7. Equation (5-6c) is a simplification that considers the seismic force distribution to be proportional to the vertical distribution of the structure's weight. The results differ only slightly when most of the structure mass is contained in the stored water, which is the case for most elevated tanks. Where the dead load exceeds approximately 25% of the total weight, Eq. (5-6b) should be used. The simplest and most conservative approach is to consider the entire structure mass located at a single level, the centroid of the stored water. An analysis that considers the individual mass of stored water, vessel structure, and pedestal is usually sufficient for evaluating lateral seismic forces.

A5.1.2.8.2.1.9 Accidental torsion—ASCE/SEI 7 requires the inclusion of torsional moment caused by an assumed displacement of the mass from its actual location by a distance equal to 5% of the structure's dimension perpendicular to the direction of the applied forces. This requirement is equivalent to increasing the shear stress in the pedestal wall by 5% at sections where there are no openings. Design of the pedestal wall is rarely controlled by horizontal shear stress, and to simplify calculations, the torsional moment may be neglected when it results in in-plane shear less than 5% of the shear strength of the pedestal wall per unit length of circumference. In structures with large openings that are subjected to high seismic loads, the torsional effects may be significant and should be included.

A5.1.2.9 Vertical load eccentricity—Eccentricity of dead and water loads causes additional overturning moments that should be accounted for in the design. Eccentricity occurs when:

- The tank is not concentric with the pedestal;
- The pedestal is out-of-plumb; or
- The foundation tilts because of differential settlement.

The total eccentricity included in Eq. (5-13a) consists of a 1 in. (25 mm) allowance for tank eccentricity with respect to the pedestal, plus an eccentricity of 0.25% times the height from bottom of foundation to top of pedestal measured at the wall. The latter term is intended to account for out-of-plumb construction and foundation tilt. The combination of these effects is random, and the deviations implied by Eq. (5-13a) should not be used as construction tolerances.

It is assumed that half the minimum eccentricity in Eq. (5-13a) is due to tilting of the foundation (foundation tilt of 1/800). When a geotechnical investigation indicates that differential settlement across the foundation width is expected to be higher than that amount, the additional tilt is to be included in determination of the vertical load eccentricity in Eq. (5-13b).

A5.1.2.11 Creep, shrinkage, and temperature—Generally, concrete creep decreases the forces associated with restrained deformations at the boundaries of shell elements and at discontinuities.

Shrinkage generally causes cracking of components of elevated tanks at restrained boundaries, such as the top of foundation, intermediate floor slabs, corners of openings, or locations where there are significant differences in concrete age of adjacent elements. Reinforcement is needed at these locations to control this cracking.

The detrimental effect of through-thickness and in-plane temperature differences is tension in the concrete that may cause cracking. Where minimum reinforcement is provided and where temperature differences are not excessive, thermal effects may be disregarded.

A5.1.3 Strength recommendations—concrete structure

A5.1.3.2 Design methods—The strength design method of ACI 318 is the preferred method for design of concrete elements not in contact with stored water, and ACI 350 is the preferred method for design of concrete members in contact with stored water.

A5.1.3.3 Minimum reinforcement

A5.1.3.3.1 Flexural members—The minimum flexural reinforcement ratio of $3\sqrt{f'_c}/f_y$ in inch-pound units ($0.25\sqrt{f'_c}/f_y$ in SI units) in the tension face is the same as required by ACI 318. This requirement is intended to prevent abrupt strength changes at the onset of cracking.

A5.1.3.3.2 Direct tension members—The minimum reinforcement ratio of $5\sqrt{f'_c}/f_y$ in inch-pound units ($0.42\sqrt{f'_c}/f_y$ in SI units) for regions of significant tension stress is based on equating the cracking strength of plain concrete to f_y . The direct tension cracking strength is taken equal to two-thirds the modulus of rupture, $7.5\sqrt{f'_c}$ in inch-pound units ($(5/8)\sqrt{f'_c}$ in SI units). This requirement is intended to prevent abrupt strength changes when cracking occurs.

A5.1.4 Serviceability recommendations—concrete structure

A5.1.4.2 Distribution of flexural and tension reinforcement—Section 5.1.4.2 is a crack control serviceability check that limits crack widths at service loads for flexure and direct tension.

Control of cracking in slabs and shell elements takes place at locations where maximum tension steel stress occurs at points of maximum moment, and at points where reinforcement is terminated.

Equation (5-14) provides a distribution of reinforcement that will reasonably control flexural cracking, and is also recommended for controlling cracking due to direct tension. It follows the approach of ACI 318 of emphasizing reinforcing details rather than actual crack width calculations.

Equation (5-14) is not specifically intended for members subject to direct tension; for these members, it is recommended to limit calculated crack width w to 0.013 in. (0.33 mm) using Eq. (A5-2a). Equation (A5-2a) is the Gergly-Lutz expression that was developed for flexural members and was the basis for distribution of flexural reinforcement in earlier editions of ACI 318 using the z factor. Numerically, z is equal to $w/(k_w\beta)$

$$w = k_w\beta f_s^3 \sqrt[3]{d_c A} \quad (\text{A5-2a})$$

where

- k_w = crack width constant;
 - = 76×10^{-6} in.²/kip (11×10^{-6} mm²/N) for members subject to flexure;
 - = 100×10^{-6} in.²/kip (14.5×10^{-6} mm²/N) for members subject to direct tension;
- β = ratio of distances to the neutral axis from the extreme tension fiber and from the centroid of the main reinforcement;
 - = 1.2 for members subject to flexure;
 - = 1.0 for members subject to direct tension; and
- A = area defined in Fig. A5.1.

The direct tension limit is based on the following crack width equation for direct tension given in ACI 224.2R

$$w = 0.138 f_s d_c \sqrt{1 + \left(\frac{s}{4d_c}\right)^2} \approx 0.10 f_s^3 \sqrt[3]{d_c A} \quad (\text{A5-2b})$$

for s/d_c between 1 and 2.

A5.2—Design of components common to both composite and concrete tank types

A5.2.2 Pedestal

A5.2.2.1 General—The provisions of Chapter 19 of ACI 318-05 are the basis for analysis and design of shell elements of the pedestal. Applicable sections of Chapters 10, 11, 12, and 21 of ACI 318-05 are also incorporated into the design. Methods of analysis can include classical theory, simplified mathematical models, or numerical solutions using the finite element method, finite differences, or numerical integration techniques. The general analysis should consider the effects of restraint at the boundaries of shell elements. The intent of this section is to not restrict analysis and design methods.

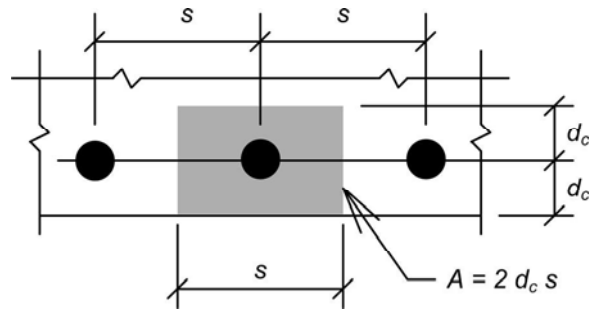

Fig. A5.1—Effective tension area of concrete.

Designs based on analysis using finite element or finite difference solutions are permitted.

Experience with pedestals of elevated water storage tanks is generally in regions where the peak effective ground acceleration is 0.20g or less, and elastic response is expected. This document provides design procedures for sites to 0.40g peak effective ground acceleration. Designers are cautioned to carefully evaluate structural response, strength, and requirements for inelastic behavior in higher seismic regions.

A5.2.2.2 Details of wall and reinforcement

A5.2.2.2.2 Specified compressive strength—The specified compressive strength of concrete is limited to 5000 psi (35 MPa). This restriction is based on current design methods and construction procedures, and is not intended to exclude the use of higher-strength concrete. The design and construction problems associated with thin concrete elements should be addressed by the user when higher-strength concrete results in thin sections.

A5.2.2.2.3 Vertical load capacity—The eccentricity coefficient C_e accounts for the reduction in the load-carrying capacity of the wall at locations where through-thickness flexure occurs. The coefficient C_e is 0.65 for e/h of 0.167 (where the centroid of the vertical load is within the kern of the cross section), and 0.80 for minimum e/h of 0.10. C_e may be considered to vary linearly for intermediate values of e/h .

Self-straining (discontinuity) forces occur in the cylindrical pedestal at connections with slabs, diaphragms, or domes and other discontinuities that cause through-thickness flexure and shear. As-built deviation from the theoretical shape causes additional flexure and shear. The combined flexure from these effects is used in determining the eccentricity ratio calculated as $e/h = M_{uw}/(P_{uw}h)$.

Specifications for composite steel-concrete tanks typically limit the eccentricity coefficient C_e to 0.647 with the centroid of the load assumed to be within the kern or middle-third of the cross section. This assumed eccentricity is sufficiently large to include the calculated eccentricity in most cases, and little, if any, further analysis is generally required.

All-concrete tanks have a smaller diameter but thicker pedestals than composite tanks, and the effect of self-straining (discontinuity) forces will be greater. Accepted current practice for all-concrete tanks is to perform a detailed analysis to determine through-thickness flexure and the global loads acting on the unit width cross section. The cross

section is then designed as a beam-column with an eccentricity coefficient C_e of 0.80, and with compression reinforcement when required for strength.

The concrete pedestals of composite concrete-steel and all-concrete elevated tanks are cylindrical (shell-type) structures with relatively thin walls. Such structures, when subjected to end compression that results from the weight of the tank filled with water that it supports, buckle in different buckle patterns depending on their length, diameter, and wall thickness. The regions of these patterns are delineated by the parameter Z defined as

$$Z = 1.9(L_g/d_w)^2(d_w/h)$$

Relatively short cylinders of thin wall construction for which $Z < 2.85$ buckle as elastic plates. Relatively long cylinders for which $Z > (d_w/h)^2$ buckle as Euler columns. Cylinders that are in between the short and long categories buckle in a diamond-shaped pattern. Pedestals of elevated tanks generally do not fall in the short category. Pedestals of composite concrete-steel elevated tanks can be expected to buckle in the diamond-shaped pattern. Pedestals of sufficiently tall concrete elevated tanks can be expected to buckle as columns.

For column buckling of pedestals

$$P_{cr} = \pi^2 EI / (kL_g)^2$$

$$P_{mw} = 0.85f'_c A_w \{ C_e [1 - A_{st}/A_w + f_y A_{st} / 0.85f'_c A_w] \} \approx 0.85f'_c A_w$$

The factor of safety against buckling is

$$F_s = [\pi^2 EI / (kL_g)^2] / 0.85f'_c A_w$$

with

$$\begin{aligned} f'_c &= 4000 \text{ psi (28 MPa);} \\ E &= 1,800,000 \text{ psi (12 GPa) to allow for microcracking} \\ &\text{and creep of concrete;} \\ k &= 2.1; \\ I/A_w &= d_w^2/8; \end{aligned}$$

Leads to $F_s = 47.1(d_w/L_g)^2$, with $F_s = 1.4/0.65$, $L_g/d_w = 4.7$.

Cylindrical shells that buckle in a diamond-shaped pattern are sensitive to imperfections. The critical buckling load obtained from tests on thin metal cylinders that buckle with the diamond-shaped pattern is

$$P_{cr} = 2CEhA_w/d_w$$

$$C = 0.6[1.0 - 0.9(1.0 - e - \theta)]$$

$$\theta = 0.0442(d_w/h)^{1/2}$$

then

$$F_s = 2CEA_w(h/d_w) / C0.85f'_c A_w$$

The practice of designing pedestals for composite concrete-steel elevated tanks limits d_w/h to 80.

With

$$\begin{aligned} d_w/h &= 80; \\ f'_c &= 4000 \text{ psi (28 MPa);} \\ E &= 1,800,000 \text{ psi (12 GPa) to allow for microcracking} \\ &\text{and creep of concrete;} \\ C_e &= 0.647; \text{ and} \\ F_s &= 7.7. \end{aligned}$$

Pedestals with d_w/h greater than 80 result in a factor of safety that is less than 7.7. For $d_w/h \approx 230$, the factor of safety is $1.4/0.65 = 2.15$.

The aforementioned practice, applicable to pedestals without openings, shows that buckling will not control the design of such pedestals of composite concrete-steel and all-concrete elevated tanks until taller and thinner-walled pedestals are considered. Support pedestals of elevated tanks are typically specified with large truck door openings. Sometimes two such openings are specified on the opposite sides of a pedestal. Research (Meller and Bushnell 1982) shows that openings with widths that are large relative to the circumference of a cylindrical shell, such as the pedestal, significantly reduce the buckling strength of the shell. The designer should evaluate each case individually and, if required, perform an analysis including detrimental effects of large openings on the buckling capacity.

A5.2.2.3.4 Foundation rotation—Radial rotation of the foundation is that rotation whose vector is perpendicular to a radial vertical plane that cuts the pedestal wall and foundation and includes the vertical centerline of the pedestal. The bending in the pedestal wall resulting from radial rotation of flexible raft or eccentrically loaded annular ring foundations can be significant, and may control the design at the base of the wall in these situations.

A5.2.2.4 Circumferential bending—Circumferential bending of the pedestal wall causes bending stresses in the wall that vary linearly through its thickness and may vary with the height of the wall. Circumferential bending of annular ring foundation, caused by radial rotation of the pedestal wall, causes bending stress that is constant across the width and varies linearly with the depth of the foundation ring.

A5.2.2.4.1 General—It is not necessary to add circumferential wind effects to any other loads or effects in determining the requirements for horizontal reinforcement.

A5.2.2.4.2 Design moment M_h —The equation for circumferential bending moment uses a moment coefficient of 0.052 that was determined from an analysis of a ring subjected to the wind pressure distribution defined in Table 4.4.1(b) of ACI 334.2R-91. The comparable moment coefficient in Eq. (4-21) of ACI 307-98 is 0.078, and is based on a somewhat different pressure distribution. The pressure distribution for cooling tower shells is considered more appropriate for the proportions of concrete-pedestal water storage tanks where circumferential bending is significant. The wind pressure for calculating circumferential bending includes a gust response factor.

A5.2.2.4.3 Vertical distribution—Examples of effective diaphragms include: foundations, intermediate storage floors that are connected to the wall, floor domes and slabs, and concrete vessel structural elements supporting the contained

water. Effective restraint is conservatively assumed to act only within a vertical distance of $0.5d_w$ above and below the effective diaphragm; longer effective lengths may be used when an analysis using the shell characteristic is made.

A5.2.2.5 Openings in walls

A5.2.2.5.2 Simplified method—The simplified method is a name for dealing with small openings less than 36 in. (900 mm) in width. When these provisions were originally developed in the mid-1990s, ACI 307 (chimneys) and ACI 313 (silos) were used in part as source material. This and the effective column approach in the following section have been used for routine design for the last 15 to 20 years without any known problems. Where finite element analysis has been performed, the result is typically that these methods are conservative.

A5.2.2.5.3 Effective column—Vehicle impact loads can be determined from AASHTO specifications (AASHTO 2002). Concrete-filled pipe bollards are recommended for impact protection at doors for vehicular access.

A5.2.2.5.4 Pilasters—Pilasters may be used at large openings such as truck doors where congestion of reinforcement occurs. Pilasters need not be symmetrical about the vertical centerline of the wall. Nonsymmetrical arrangements, however, have out-of-plane forces and deformations near the end of the pilaster that should be considered in the design. The forces and deformations in this area are best evaluated with finite element analysis of the opening.

A5.2.2.5.5 Horizontal reinforcement—The purpose of the additional horizontal reinforcement is to permit pedestal stresses to flow around the opening without producing vertical cracking above and below the opening. Equation (5-20) is based on deep beam theory and was developed around the use of reinforcement with a 60,000 psi (420 MPa) yield strength. The 0.14 moment coefficient includes an increase in the average load factor from 1.5 to 1.7.

A5.2.2.6 Radial shear design—Radial shear forces occur at radial concentrated loads, and adjacent to restrained boundaries such as the top of foundation and the tank floor.

A5.2.2.7 In-plane shear design

A5.2.2.7.3 Shear force distribution—In-plane shear force per unit length of circumference in a cylindrical section without openings has a sine distribution with maximum tangential shear of $2V_u/\pi d_w$ at 90 degrees to the direction of the load. This leads to the concept of dividing the cylindrical section into four quadrants, a tension and compression flange to resist moment, and two parallel walls to resist shear forces. All four segments are of length $0.78d_w$, with centroid at distance $0.45d_w$ from the center. The average force in the assumed shear walls is the same as the maximum tangential shear of $2V_u/\pi d_w$ at 90 degrees to the direction of the load.

A5.2.2.7.4 Effective shear area—The effective shear area defined in this section is based on the concept of in-plane shear being resisted by two parallel shear walls of length $0.78d_w$ as shown in Fig. A5.2. Torsional effects are assumed resisted by shear in the transverse quadrants such that there is no significant deviation from the distortion of the cylindrical section without openings. The effect of openings is to decrease total shear area A_{cv} and results in a concomitant

increase in unit shear that is considered to reflect the redistribution of unit shear force around openings in the parallel shear walls. When the cumulative width of openings, b_x , is greater than half the effective shear wall length, a more comprehensive analysis method should be used for design.

A5.2.2.7.5 Maximum shear—The maximum design shear limits are based on Chapter 21 of ACI 318-05. Generally, walls should be proportioned such that factored shear force is not greater than $2\sqrt{f'_c} A_{cv} (\sqrt{f'_c} A_{cv}/6)$. This proportioning eliminates the need for shear reinforcement greater than minimum requirements.

The equations in Fig. A5.2 are valid for openings without significant pilasters. Monolithic pilasters tend to change force distribution by attracting a larger portion of the shear force. If such pilasters are present and the structure is located in a region of moderate or high seismic risk, shear distribution should be determined by more accurate methods.

A5.2.2.7.6 Shear strength—The equation for nominal shear strength V_n is based on Eq. (21-7) from Chapter 21 of ACI 318-05 for shear walls and diaphragms. High in-plane shear forces usually only occur with seismic forces, and the use of this equation results in a design compatible with ACI 318 seismic requirements.

The coefficient α_c in Eq. (5-24) is from Section 21.7.4.1 of ACI 318-05. In inch-pound units, the linear portion having values between 2.0 and 3.0 can be written in equation form as $\alpha_c = 6 - 2(h_r/d_w)$. Substituting M_u/V_u for h_r , and $0.78d_w$ for d_w gives $\alpha_c = 6 - 2.56M_u/(V_u d_w)$. In Eq. (5-24), the 2.56 coefficient is rounded to 2.5. In the SI system, the linear portion varies between 1/6 and 1/4, and results in $\alpha_c = 0.5 - 0.21M_u/(V_u d_w)$.

A5.2.2.7.7 Design location—The location for determining nominal shear strength is the lower of the midheight of the largest opening or a distance equal to one-half the effective shear wall width above the base. The second criterion is consistent with ACI 318, and the first ensures that shear across openings is checked.

A5.2.2.7.8 Reinforcement—The minimum reinforcement requirements in Table 5.2 conform to the requirements of Chapter 21 of ACI 318-05 for shear walls. The additional requirements of Section 5.2.2.7.8 apply only to regions of high seismicity. Areas of high seismicity risk regions are generally defined as regions where S_{D1} is greater than or equal to 0.20, or Seismic Zones 3 and 4 where zone maps are used in earlier editions of model building codes.

A5.3.2.2.1 Load effects—Anchorage between the steel tank and the concrete support is checked for seismic loads assuming elastic behavior (design seismic load multiplied by seismic response factor $R = 1$). This requirement precludes a possible connection failure during a seismic event.

A5.3.3 Tank vessel—American Water Works Association standard AWWA D100 has been used for design of the steel portion of elevated composite tanks. AWWA Committee D170 is writing a standard for design and construction of elevated composite tanks that covers the entire structure.

Membrane theory of thin elastic shells of revolution is the basis for design of shell elements of composite tanks. Membrane theory only considers the membrane forces in the shell, and ignores the restrained deformations that occur at

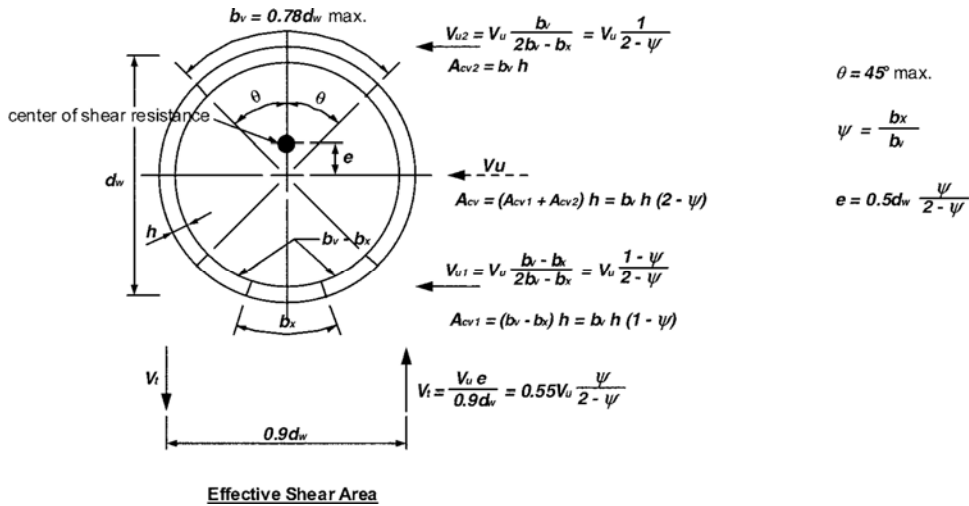

Fig. A5.2—Effective shear area.

shell intersections and supported edges. This is adequate for design where bending stiffness is sufficiently small that the resulting flexural strain is not significant, or the shells are flexurally stiff but loaded and supported in a manner that avoids the introduction of significant flexural strain. Membrane analysis includes analysis of boundary elements, such as tension or compression rings that resist unbalanced edge forces at shell discontinuity junctures.

Procedures based on strain compatibility are used for analysis of shell discontinuity junctures where bending stresses may be significant. Classical shell theory, simplified mathematical models, or numerical solutions using the finite element method, finite differences, or numerical integration techniques can be used to determine in-plane membrane forces, shear, and flexure.

CHAPTER A6—GEOTECHNICAL RECOMMENDATIONS

A6.2—Foundation depth

Maps of frost penetration depth are available from the U.S. Weather Bureau, or can be found in model building codes or their commentaries.

A6.3—Settlement limits

Elevated tanks and their foundations are relatively rigid structures that can undergo significant total settlement without distress. Settlement of deep foundations is usually smaller than that of shallow foundations, and the smaller settlement limit reflects the expected behavior. The effects of foundation movement relative to slabs and piping should be considered and provided for by properly designed connection details.

Tilting of the structure caused by differential settlement across the foundation width causes secondary overturning moments, and the structural effects of this are accounted for in the design of the superstructure and foundation by the eccentricity load term *G*. A minimum assumed tilt of 1/800 is included in the design through Eq. (5-13a). Larger differential tilt is permitted when included in Eq. (5-13b).

Table A6.1—Deep foundations performance factor

Ultimate capacity in accordance with Section	Ultimate strength performance factor
6.5.1(a)	0.5
6.5.1(b)	0.75
6.5.1(c)	0.75
6.5.1(d)	0.6

A6.4—Shallow foundations

A global factor of safety of 3.0 is used for sizing shallow foundations using allowable stress design. Where settlement controls the design, the factor of safety is even larger. Analytical methods for determining the maximum bearing pressure can be found in references on foundation design.

A6.5—Deep foundations

A variable global factor of safety that depends on the method of determining the ultimate capacity is used with deep foundations. Where settlement controls the design, the factor of safety will be even larger. Deep foundation elements such as drilled piers, which have capacity based on calculations, use a minimum factor of safety of 3.0, which is the same as for shallow foundations. Where static load testing is used, the safety factor is reduced to 2.0. Analytical methods for determining the maximum pile or pier load can be found in references on foundation design.

Ultimate strength design may also be used to determine the required number of drilled piers or piles using the following equation

$$Q_u = \phi_p Q_r$$

The factored pile or pier load Q_u is calculated from loads in Section 5.1.2.2.1.1. The deep foundation performance factor ϕ_p is from Table A6.1.

The deep foundation performance factor ϕ_p used with ultimate strength design provides the same global factor of safety as listed in Table 6.1 when used with the factored load combinations of Section 5.1.2.2.1.1, where the average load factor is approximately 1.4.

A6.6—Seismic recommendations

Relatively fine-grained soils in a relatively loose state of compaction, and in a saturated or submerged condition, are subject to liquefaction during earthquake excitation. Where these soils occur, the suitability of a site for a concrete-pedestal elevated water storage tank should be carefully evaluated. Any special precautions that are required in the design should be identified before design.

CHAPTER A7—APPURTENANCES AND ACCESSORIES

A7.4—Tank access

A7.4.1.3 Attachment to concrete—Headed stud patterns need to be such that studs penetrate the reinforcing steel pattern and not interfere with post-tensioning blockouts, if applicable.

A7.4.2 Ladders—The following details are commonly used for ladders:

(a) Side rails are a minimum 3/8 in. (10 mm) by 2 in. (50 mm) with a 16 in. (410 mm) clear spacing. Rungs are a minimum 3/4 in. (20 mm) round or square, spaced at 12 in. (300 mm) centers. The surface should be knurled, dimpled, coated with skid-resistant material, or otherwise treated to minimize slipping; and

(b) At platforms or landings, the ladder extends a minimum of 48 in. (1.2 m) above the platform. Ladders are secured to the adjacent structure by brackets located at intervals not exceeding 10 ft (3 m). Brackets have sufficient length to provide a minimum distance of 7 in. (180 mm) from the center of rung to the nearest permanent object behind the ladder.

(c) Where cages are provided, ladders should be offset at landing platforms. The maximum interval between platforms should not exceed 30 ft (9 m). Cages should start between 7 and 8 ft (2.1 and 2.4 m) above the base of the ladder and should extend a minimum of 48 in. (1.2 m) above the offset landing platform.

A7.4.5 Concrete tank vessel access openings—If the access tube penetrates the concrete tank roof dome, two access hatches are required. Openings may be protected by a handrail or safety net.

A7.4.6 and A7.4.7 Steel vessel roof openings and floor manhole—Commonly used opening sizes for access to the tank interior are given. Openings used only for personnel access should have a least dimension of 24 in. (610 mm) or larger. Larger openings may be required for painter's equipment or other interior maintenance items. At least one opening should be of sufficient size to accommodate the largest anticipated equipment. A tank floor manhole is not required for operation and maintenance of the tank, but is considered an appurtenance for safety reasons in that it provides a means of egress other than the roof manholes. Furthermore, it is a practical access opening during construction and out-of-service maintenance.

A7.6—Above-ground piping

A7.6.2.6 Entrance details—Typically, inlet safety protection is provided for pipes of 18 in. (460 mm) diameter and greater, but some jurisdictions may require inlet protection for pipes as small as 8 in. (200 mm) in diameter.

A7.6.3 Overflow—An overflow is a protection device intended to prevent overfilling and possible overloading of the tank. An overflowing tank should be considered an emergency condition. The condition causing the tank to overflow should be promptly determined and rectified by the operator.

A7.8—Interior floors within pedestal

A7.8.2 Slabs-on-ground

A7.8.2.1 Minimum recommendations—It is assumed that if door openings are less than 8 ft (2.4 m) wide, the floor slab will only be subjected to foot traffic and occasional light vehicle traffic. Truck loading should be expected for wider doors.

The optimum concrete mixture has the maximum flexural strength with the least mixing water to minimize shrinkage. Concrete with a specified compressive strength in the range of 3500 to 4000 psi (24 to 28 MPa) and a w/cm less than 0.45 can be expected to provide reasonable performance.

The 5 in. (125 mm) minimum thickness is recommended when only light vehicle traffic is expected, and a 4 in. (100 mm) thickness may be used when only foot traffic is expected. The 6 in. (150 mm) minimum thickness recommended where truck doors are furnished is adequate for 15 ton (13.6 tonne) axle loads for most subgrade soils.

The minimum reinforcement requirements in [Table 7.1](#) are shrinkage and temperature steel requirements in accordance with ACI 318.

A7.8.2.3 Joints—The inside diameter of most concrete pedestals is less than 70 ft (21 m), and the minimum reinforcement in [Table 7.1](#) is adequate for controlling cracking for slab widths to this width. This criterion is based on the subgrade drag equation in ACI 360R using a friction coefficient of 2.0 and an allowable stress in reinforcement of 40,000 psi (276 MPa). Continuous reinforcement with contraction joints is commonly used.

A7.8.2.5 Subgrade—A minimum compaction of 95% modified Proctor density is recommended for backfill supporting a slab-on-ground subject to vehicle traffic. Otherwise, backfill should be compacted to a minimum of 90% or more modified Proctor density.

A7.8.3 Intermediate floors—Various structural configurations are used for above-grade floors. The simplest is a flat slab supported by the pedestal wall, which may be used for small-diameter pedestals. For larger spans, flat slabs with intermediate columns, and concrete or steel beams supporting a concrete slab are generally used. Care should be taken that the loads from the beam end reactions are adequately transferred to the pedestal wall, and are accounted for in the design.



American Concrete Institute®
Advancing concrete knowledge

As ACI begins its second century of advancing concrete knowledge, its original chartered purpose remains "to provide a comradeship in finding the best ways to do concrete work of all kinds and in spreading knowledge." In keeping with this purpose, ACI supports the following activities:

- Technical committees that produce consensus reports, guides, specifications, and codes.
- Spring and fall conventions to facilitate the work of its committees.
- Educational seminars that disseminate reliable information on concrete.
- Certification programs for personnel employed within the concrete industry.
- Student programs such as scholarships, internships, and competitions.
- Sponsoring and co-sponsoring international conferences and symposia.
- Formal coordination with several international concrete related societies.
- Periodicals: the *ACI Structural Journal* and the *ACI Materials Journal*, and *Concrete International*.

Benefits of membership include a subscription to *Concrete International* and to an ACI Journal. ACI members receive discounts of up to 40% on all ACI products and services, including documents, seminars and convention registration fees.

As a member of ACI, you join thousands of practitioners and professionals worldwide who share a commitment to maintain the highest industry standards for concrete technology, construction, and practices. In addition, ACI chapters provide opportunities for interaction of professionals and practitioners at a local level.

American Concrete Institute
38800 Country Club Drive
Farmington Hills, MI 48331
U.S.A.

Phone: 248-848-3700

Fax: 248-848-3701

www.concrete.org

Guide for the Analysis, Design, and Construction of Elevated Concrete and Composite Steel-Concrete Water Storage Tanks

The AMERICAN CONCRETE INSTITUTE

was founded in 1904 as a nonprofit membership organization dedicated to public service and representing the user interest in the field of concrete. ACI gathers and distributes information on the improvement of design, construction and maintenance of concrete products and structures. The work of ACI is conducted by individual ACI members and through volunteer committees composed of both members and non-members.

The committees, as well as ACI as a whole, operate under a consensus format, which assures all participants the right to have their views considered. Committee activities include the development of building codes and specifications; analysis of research and development results; presentation of construction and repair techniques; and education.

Individuals interested in the activities of ACI are encouraged to become a member. There are no educational or employment requirements. ACI's membership is composed of engineers, architects, scientists, contractors, educators, and representatives from a variety of companies and organizations.

Members are encouraged to participate in committee activities that relate to their specific areas of interest. For more information, contact ACI.

www.concrete.org



American Concrete Institute®
Advancing concrete knowledge