

SOE in France

*An Account of the Work of the
British Special Operations Executive
in France*

1940–1944

M. R. D. FOOT

Une guerre obscure et méritoire

Louis Gros

WHITEHALL HISTORY PUBLISHING



in association with

FRANK CASS

LONDON • PORTLAND, OR



**Also available as a printed book
see title verso for ISBN details**

SOE IN FRANCE

WHITEHALL HISTORIES: GOVERNMENT OFFICIAL HISTORY SERIES
ISSN: 1474-8398

The Government Official History series began in 1919 with wartime histories, and the peacetime series was inaugurated in 1966 by Harold Wilson. The aim of the series is to produce major histories in their own right, compiled by historians eminent in the field, who are afforded free access to all relevant material in the official archives. The Histories also provide a trusted secondary source for other historians and researchers while the official records are still closed under the 30-year rule laid down in the Public Records Act (PRA). The main criteria for selection of topics are that the histories should record important episodes or themes of British history while the official records can still be supplemented by the recollections of key players; and that they should be of general interest, and, preferably, involve the records of more than one government department.

The United Kingdom and the European Community:
Vol. I: The Rise and Fall of a National Strategy, 1945–1963
Alan S. Milward

Secret Flotillas
Vol. I: Clandestine Sea Operations to Brittany, 1940–1944
Vol. II: Clandestine Sea Operations in the Mediterranean, North Africa and the Adriatic, 1940–1944
Sir Brooks Richards

SOE in France
M. R. D. Foot

The Official History of the Falklands Campaign:
Vol. I: The Origins of the Falklands Conflict
Vol. II: The 1982 Falklands War and Its Aftermath
Lawrence Freedman

Defence Organisation since the War
D. C. Watt

SOE in France

*An Account of the Work of the
British Special Operations Executive
in France*

1940–1944

M. R. D. FOOT

Une guerre obscure et méritoire

Louis Gros

WHITEHALL HISTORY PUBLISHING

in association with

FRANK CASS

LONDON • PORTLAND, OR



This edition first published in 2004 in Great Britain by
FRANK CASS PUBLISHERS
Crown House, 47 Chase Side, Southgate
London N14 5BP

and in the United States of America by
FRANK CASS PUBLISHERS
c/o ISBS, 5824 N.E. Hassalo Street
Portland, Oregon, 97213-3644

Website: www.frankcass.com

This edition published in the Taylor & Francis e-Library, 2004.

© Crown Copyright 1966

Copyright revised edition © MRD Foot 2004

Crown Copyright material from the first edition is reproduced with the permission of the
Controller of HMSO

First published in 1966 by HMSO, London.
Second impression with amendments 1968.

British Library Cataloguing in Publication Data

Foot, M.R.D. (Michael Richard Daniell), 1919–
SOE in France: an account of the work of the British
Special Operations Executive in France: 1940–1944. – 3rd
ed. – (Whitehall histories. Government official history
series)
1. Great Britain. Army. Special Operations Executive –
History 2. World War, 1939–1945 – Secret Service – Great
Britain 3. World War, 1939–1945 – Underground movements –
France
I. Title
940.5'48641

ISBN 0-7146-5528-7 (cloth)

ISSN 1474-8398

Library of Congress Cataloging-in-Publication Data

Foot, M.R.D. (Michael Richard Daniell), 1919–
SOE in France: an account of the work of the British Special Operations Executive in
France: 1940–1944 / by M.R.D. Foot.–Rev. ed.
p. cm
Includes bibliographical references and index.

ISBN 0-203-49613-2 Master e-book ISBN

ISBN 0-203-58238-1 (Adobe eReader Format)

ISBN 0-7146-5528-7 (Print Edition)

1. World War, 1939–1945 – Underground movements – France. 2. World War,
1939–1945 – Secret service – Great Britain. 3. Great Britain. Special Operations
Executive – History. I. Title: Special Operations in France. II. Title
D802.F8F6 2003
940.54'8641'0944–dc22

2003055603

*Published on behalf of the Whitehall History Publishing Consortium. Applications to reproduce
Crown copyright protected material in this publication should be submitted in writing to:
HMSO, Copyright Unit, St Clements House, 2-16 Colegate, Norwich NR3 1BQ. Fax: 01603 723000. E-
mail: copyright@hmso.gov.uk*

Contents

List of Illustrations	vii
Preface	ix
Abbreviations	xv
Introduction	xx
Analytical Table of Contents	xxvi
Maps	xxxii
 Part I: Structure	
I The Origins of SOE	3
II What SOE Was	13
III Recruiting and Training	41
IV Communications	59
by sea	60
by air	71
by land	87
by signal	94
in the field	103
V Security in France	106

Part II: Narrative

VI	Politics and the Great Game	119
VII	Opening Gambits: 1940–1941	136
VIII	Development: 1942	163
IX	Middle Game: 1943	209
X	A Run of Errors: 1943–1944	258
XI	Pressure Mounting: January to May 1944	309
XII	A Run of Successes: June to September 1944	339
XIII	Aftermath	368
XIV	Strategic Balance Sheet	380
	Appendices:	
A	Sources	395
B	Women Agents	414
C	Supply	419
D	Notes for Pilots on Lysander and Hudson Pick-up Operations	427
E	Report by Jean Moulin, October 1941	437
F	Typical F Section Operation Orders	447
G	Industrial Sabotage	453
H	F Section Activity Diagram	466
I	Tables of Dates	468
	Notes	472
	Index	507

Illustrations

Between pages 248 and 249

Note on the illustrations: Only two of the photographs below are professional studio portraits. The rest are either action snapshots, or photographs taken during the war under a hard light for purposes of identification. They are not intended to flatter, but they may reveal.

Some Baker Street personalities

Gubbins, Buckmaster, Bodington

Charles de Gaulle

Jean Moulin

Early agents

Pierre de Vomécourt, Ben Cowburn, Virginia Hall, Christopher Burney

1942 vintage

Charles Grover-Williams, Robert Benoist, Michael Trotobas, Gustave Biéler, Brian Rafferty

The *Prosper* circle

Francis Suttill, Gilbert Norman, Jack Agazarian, France Antelme, Noor Inayat Khan

F's three colonels

Starr, Heslop, Cammaerts

Henri Déricourt

Four who came back

Claude de Baissac, Harry Rée, Harry Peulevé, Yvonne Baseden

Ratier workshop at Figeac after treatment

Some figures in RF section

Paul Rivière, Michel Brault, Yeo-Thomas, Raymond Basset, André Jarrot

More RF agents

Pierre Fourcaud, Yvon Morandat, Pierre Rosenthal, Paul Schmidt

Daylight mass drop in Corrèze, 14 July 1944

Daylight mass drop to the Vercors, 14 July 1944

Worm's-eye view: removing stores from reception

ACOLYTE tackles some points

'Wizard prang': a PIMENTO derailment

Place de l'Opéra, 25 August 1944

Preface

It was long British government policy that the archives of SOE, the wartime Special Operations Executive, must remain secret, like the archives of any other secret service. The reason for this is not, as followers of Commander Bond's adventures might imagine, that SOE carried on its work after the end of the war, for it was wound up early in 1946. Nor is it true that irresponsible staff officers made such fearful errors that there is a whole discreditable story to be hushed up. There were certainly hair-raising mistakes of several kinds; so there always are, in any service and in any war. A number of writers have fastened on one or two of these mistakes, which bore on less than five per cent of SOE's effort in France, and inflated them – for lack of balancing evidence – into phantasmagorical sketches of SOE as a kind of Moloch that devoured innocent children for evil motives. On the other side of the account, many of the substantial triumphs have remained quite unknown except to the people who were concerned in them; while some of the success stories published, with fact and fiction closely interwoven, have done the force's reputation quite as much harm as good. An effort that German as well as allied generals believe shortened the European war by about six months cannot have been quite devoid of strategic value; readers must make up their own minds about whether the price paid for SOE's undoubted successes was too high. I have taken as my working motto Othello's 'nothing extenuate, Nor set down aught in malice', and have tried simply to explain what happened, without conscious bias in any direction.

In the turmoil of under-informed publicity that surrounded what appeared in English about secret operations in France, historians have been overlooked. They have a duty to discover what they can; and a right to be told why so far, as a matter of policy, they have been told so little officially from London. The policy was adopted because much of SOE's work overlapped with the work of other secret services, whose contacts, methods, and devices no one in authority wished to reveal. I have done what I can to respect this wish, without compromising with the needs of history or of common sense. While the world is divided between sovereign states, these

states need intelligence and security; this is simply a fact of current international life, which radicals and idealists can rail against but cannot alter. Little significant difference to the balance of the work has been made by such omissions as discretion has compelled me to make.

This book has had a history; in no way comparable for excitement, interest, or danger to the adventures in France that it describes, but one nevertheless which may be worth recording. The project derives from the continuing concern expressed, both in parliament and outside it, that there should be an accurate and dispassionate account of SOE's activities in the war of 1939–45. This concern led Harold Macmillan, while Prime Minister, to authorise some research. In the Foreign Office, it was determined to find out whether a study could be written of what SOE did in France. I was invited to write it, simply because I knew a little already about French resistance and the history of the war, was a trained historian, and was prepared to devote most of my time to the task. In fact, it absorbed almost all my attention from the autumn of 1960 to the end of 1962, when I completed the original draft, and has taken up a good deal of my own time, and much of that of other people, since.

Various authorities read the draft, and decided that it might be published, and an official announcement to this effect was made in parliament.¹ The draft was thereupon set up in galley proof, and circulated to a number of people who had a claim to be heard on what it said: some of them persons of great eminence, and some of them exceptionally well informed about its subject. Their comments led in turn to some further research and to some changes and amplifications in the text.

My object has been to explain the part played by SOE in the battle for France's liberation from the nazis that began with the collapse of June 1940. To do this I have had to make a preliminary sketch of SOE's origins and nature; I have taken the political history of England and France for granted, for much is known about both. Inevitably, I have looked at the operations I have described primarily from the London end. For political reasons, the archives in Paris were long virtually unavailable to me; good agents kept few papers when at work; and SOE's relevant north African files were long ago destroyed. The resultant book will probably appear unduly jumpy and episodic; yet such a character reflects the events it describes, as they were perceived by SOE's guiding staff. All that London knew about many parts of the world for much of the war might well be confined to a handful of harrowing anecdotes, each one apparently pointless, unless seen in the light of the others. Interpreting these adventures was difficult enough even at the time. Until my research in the London archives, such as they are, was far advanced, I could not confidently place agents or their work in a strategic context; and many books show how dangerous it is to accept participants' stories without having some idea of the general picture. A single lifetime would not suffice to collect and collate all the stories of the survivors, let

alone the dead. Other historians need quickly such working material as this book contains; they can use it to help their own investigations.

I trust any surviving participants who read this history will not be put out at finding themselves treated as historical figures, usually mentioned by their surnames unadorned. This has been done for the sake of brevity and simplicity. The reader will have trouble enough below with field names for agents, in *italics*, and with the names of operations and circuits, in SMALL CAPITALS; and deserves not to be muddled further by a succession of such phrases as ‘Flight Lieutenant (subsequently Wing Commander)’. Rank in any case meant little in an organisation where a lieutenant-general served contentedly under a brigadier, and indeed a rear-admiral under a squadron-leader. Of course no sort of disrespect, to living or dead, is meant. I have ventured to make trifling changes, for simplicity’s sake, in a few quotations; confined to bringing their layout into line with the text’s, or correcting obvious and unimportant typists’ errors. Personal names are spelt, I hope, as their owners spell them; place names follow Didot-Bottin, except for such common English usages as Lyons and Marseilles. Unattributed translations are my own.

Naturally, I have tried to produce as complete, as accurate, and as fairly balanced an account as time permitted. No one will be less surprised than myself if inaccuracies remain; for the whole published literature on the subject is pitted with them, and the unpublished archives are often contradictory as well as confusing and confused. I have simply done my best to follow the professional rules for assessing historical evidence – preferring earlier to later and direct to indirect reports, and so on. Caxton begged the readers of his edition of Malory ‘that they take the good and honest acts in their remembrance, and to follow the same’. There were many more good and honest than despicable acts in the story that is to follow, which includes numerous acts of extraordinary bravery, beyond the act – brave enough in any case – of precipitating oneself, usually by parachute, in the dark, under a false name, into territory controlled by a hostile secret police: an act that many thousands of SOE’s agents carried through unflinching, in France or elsewhere, with a courage to which the nations allied against Hitler owe a large debt. I offer Caxton’s advice to any readers who may find themselves in comparable dangers. I hope there is no need to add his caution, ‘to give faith and believe that all is true that is contained herein, ye be at your liberty’; for I have taken trouble to put nothing in these pages which I have not reasonable grounds for believing true. The remaining minor errors of fact may have drawn with them slight errors in perspective, but I believe the main outlines of the tale are sound. It contradicts, directly or by implication, much that has already been printed, or circulated as gossip.

Many facilities have been afforded me in preparing this book, and I am greatly indebted to many people, not least the distinguished authorities who looked at it in proof. I have had access to all the relevant surviving files of

SOE, and to any other papers I have requested; with a few minor exceptions, noted in the appendix on sources. I need hardly say how grateful I am to those who have put their time, their memories, and other working material at my disposal; as a number of the most helpful of them wish to remain anonymous, it would be invidious to name many names. I must however name two of them: Major-General Sir Colin Gubbins, who enabled me to call on his unrivalled recollections of what went on, and Lieutenant-Colonel E. G. Boxshall, whose unfailing patience and courtesy I must often have sorely tried.

I record also my warm gratitude to four exceptionally competent foreign service secretaries, who undertook the tedious task of typing out various parts of the text; and to the following for leave to reprint copyright material: Messrs Cassell, for extracts from Sir Winston Churchill's *The Second World War*; Colonel A. Dewavrin; the Society of Authors, as the literary representative of the estate of the late A. E. Housman, and Messrs Jonathan Cape, publishers of A. E. Housman's *Collected Poems*; Mrs Josephine Dormer and the same publishers, for a passage from *Hugh Dormer's Diaries*; Messrs Putnam, for an extract from Robert Aron's *De Gaulle before Paris*; Messrs Macmillan, for quotations from Sir John Wheeler-Bennett's *Nemesis of Power* and from Anne-Marie Walters' *Moondrop to Gascony*; the Hutchinson publishing group, for extracts from George Langelaan's *Knights of the Floating Silk* and Philippe de Vomécourt's *Who Lived To See the Day*, and for the photograph of Jean Moulin from Eric Picquet-Wicks's *Four in the Shadows*; the Librairie A. Fayard for a long passage from Adrien Dansette's *Histoire de la libération de Paris*; the Office de Publicité Générale for a snapshot from Jacques Kim's *La Libération de Paris*; *Libération* for the photograph of Déricourt; and Sir Edward Spears for that of General de Gaulle.

Since this book first appeared in April 1966 I have had further help, for which I am much indebted, from various former members of SOE and of the forces of French resistance; particularly from Colonel Dewavrin. Their aid has enabled me, in the little time I have had available for work on the book, to improve it in several minor respects and to revise the account of the arrangements made in London for calling resistance into activity at the time of the invasion of Normandy. I have also taken this opportunity to modify a number of passages which gave some quite unintended personal offence, and to make explicit a few points misunderstood by reviewers.

Lastly, it must be made quite clear that though the book has been prepared under official auspices and with official help, it in no way reflects official doctrine: I am an historian, not an official, and the views given below are my own. No responsibility for any statement or opinion in these pages attaches to any organization or person but myself.

So far, lightly amended more recently, I had written thirty-five years ago. The late Charles Orenge of Fayard in Paris took to the book, and had a superb translation of it made by Mademoiselle Denise Mounier (who has recently died) which I was allowed to see for two days, but not to copy. It never appeared, presumably for political reasons – the author was fobbed off with a tale about a quarrel between clerks at Fayard and at HMSO, the original publishers. A translation of this new edition has now been sanctioned.

HMSO sold the rights on, in the early 1970s, to Thomas F. Troy's University Presses of America; which published it at Frederick, Maryland, in 1974 in his unhappily named Foreign Intelligence Book Series (no English historian likes a history book to appear with FIBS at the base of the spine). Troy in turn sold out to Greenwood Books, who kept the volume in print until a year or two ago, at a much enhanced price of £60 (\$100); it first came out at forty-two shillings (£2.10).

This version follows quite closely along the lines of the earlier ones, but there are some additions, on the strength of reliable publications and released archives; a few knotty signals problems have been cleared up; and a little more can now be said about the work of other secret services. My Foreign Office bear-leaders laid down, at our very first interview, that I was to write – so far as I could – on the understanding that there had never been such a body as SIS (Secret Intelligence Service); though I knew, and they knew that I knew, that there had. In the more relaxed era of the present century, when the continuing existence of SIS has been officially admitted, and the USSR that was long its main enemy has collapsed, I have been able to be more straightforward about a service from part of which part of SOE derived. I have also been able to say a little about the decipher and deception services, of whose major triumphs I had not heard in the 1960s.

One or two general points are worth making early. Some dons and journalists to whom risk and duty seem abhorrent nowadays seek to argue – perversely, it seems to surviving ex-resisters – that the whole resistance effort was a waste of time, and may even have retarded Europe's social development. Others know better. Perhaps the hardest point to put across is that life in the field for SOE's agents was likely to be a life of perpetual strain; as Maurice Buckmaster once put it, 'No holidays, no home leave, no local leave, no Sundays or bank holidays.'² Relaxed societies like ours forget the strains attendant on living in a world war, which were even worse for secret agents than for the rest of us.

This book has always seemed quixotic to the French historians who have read it; the new edition makes no attempt to correct this tone. SOE's ventures into France did have a quixotic element in them; yet, unlike the Don's battle with the windmill, they did exert useful impact on the real world; as the concluding chapter will show.

Legends continue to proliferate about SOE and its doings. Shakespeare warned us centuries ago against 'old men of less truth than tongue';³ such

old men's interpreters to the modern age are even less reliable. This book may help to counteract some of the more fanciful outbursts.

Moreover, the bulk of the papers on which it is based are now going public in the Public Record Office in Kew. Back in the 1960s., there was a clash between scholarship and security; security, as usual, won. I was not allowed to keep any of my notes about where my material came from, nor to make any specific references to Chiefs of Staff or Foreign Office or SOE files. I have not always been able to remedy this; hence some unavoidable lacunae in the notes.

There are several more people to whom I need to extend warm thanks for their advice, even if I have not taken all of it. I alone, of course, remain responsible for mistakes. Three successive SOE advisers to the Foreign Office, Christopher Woods, the late Gervase Cowell, and Duncan Stuart, and Valerie Collins, Cowell's and Stuart's PA, have all been prodigal of their time and help; so has an anonymous body of official archivists who kept me plied with files. At the Cabinet Office, Sir Richard Wilson, Tessa Stirling and Richard Ponman have all been supportive; and Mrs Stirling's staff undertook without complaint the tiresome task of transforming a marked book and a wodge of typescript into a fresh volume. Sybil Beaton has lent me her father Maurice Buckmaster's interleaved copy of the first edition; and Jacqueline Biéler has taught me how to spell her father's surname. A galaxy of friends and acquaintances at the Special Forces Club and in the Study Group on Intelligence have widened my horizons. I am especially grateful to the late Sir Brooks Richards, and to the Holdsworth Trust for an invaluable research grant. I am also grateful to three fellow historians for advice: Christopher Andrew, Philip Bell and Roderick Kedward. The staffs of the British Library, Cambridge University Library, Churchill College Cambridge archives, and the London Library have been uniformly helpful. Michael Sissons and James Gill at my agents, Peters Fraser & Dunlop, have been useful and patient; so has Frank Cass the publisher and his staff. My debt to my wife, for her continuing encouragement and care, is the greatest of all.

Nuthampstead
M.R.D.F.

Abbreviations

ACNS	Assistant Chief of the Naval Staff
AD/B	symbol, see page 19
ADE	Aleanza Democrática Española
AD/E	symbol, see page 20
ADMR	Assistant Délégué Militaire Régional
AD/S	symbol, see page 20
AFHQ	Allied Force Headquarters (Mediterranean)
AIIO	symbol, see page 13
AL	SOE Air Liaison
AMF	symbol, see page 32
AS	Armée Secrète
BCRA (M)	Bureau Central de Renseignements et d'Action (Militaire)
Bde	Brigade
BdS	Befehlshaber der Sicherheitspolizei
BIP	Bureau d'Information et de Presse
BOA	Bureau d'Opérations Aériennes
BRAL	Bureau de Recherches et d'Action à Londres
CAF	Corps Auxiliaire Féminin
CAS	Chief of the Air Staff
CCO	Chief of Combined Operations
CCS	Combined Chiefs of Staff
cct	circuit
CD	symbol, see page 18
CEO	Chief Executive Officer
CFLN	Comité Français de Libération Nationale
CFR	Committee on Foreign Resistance

CFTC	Confédération Française de Travailleurs Chrétiens
CGE	Comité Général d'Études
CGT	Confédération Générale du Travail
CGTU	Confédération Générale du Travail Unifiée
ch	chapter
CND	Confrérie de Notre-Dame
CNR	Conseil National de la Résistance
COHQ	Combined Operations Headquarters
COMAC	Comité d'Action
COS	Chiefs of Staff
COSSAC	Chief of Staff to the Supreme Allied Commander
cp	compare
CS	symbol, see page 4
D	symbol, see page 4
D/CD	symbol, see page 19
D/CD(O)	symbol, see page 20
DDOD(I)	Deputy Director, Operations Division (Irregular)
DF	SOE escape section
D/F	direction-finding
DGSS	Directeur-général des Services Spéciaux
DMI	Director of Military Intelligence
DMO	Director of Military Operations
DMR	Délégué Militaire Régional
DNI	Director of Naval Intelligence
D/R	symbol, see pages 20–1
DST	Direction de Surveillance du Territoire
duplic	duplicated copy
ed	edited (by), edition
EH	symbol, see page 4
EMFFI	Etat-major des Forces Françaises de l'Intérieur
ETO	European Theater of Operations
EU/P	symbol, see pages 24–5
F	SOE independent French section
FF1	Forces Françaises de l'Intérieur
FFL	Forces Françaises Libres
FN	Front National
FOPS	Future Operations Planning Staff
FTP (F)	Francs-tireurs et Partisans (Français)
Gestapo	Geheime Staatspolizei
GFP	Geheime Feldpolizei

GM	Gardes Mobiles
GMR	Groupes Mobiles de Réserve
GSO	general staff officer
GS (R)	General Staff (Research)
H	SOE Iberian section
IHTP	Institut d'Histoire du Temps Présent
III F	symbol, see page 108
IO	intelligence officer
ISRB	Inter-services Research Bureau
ISSU	Inter-service signals unit
IV F	symbol, see pages 109–10
JIC	Joint Intelligence Committee
JPS	Joint Planning Staff
KG	Kampfgeschwader
LLL	LIBERTÉ, LIBÉRATION, ET LIBÉRATION NATIONALE
LMG	light machine-gun
M	symbol, see page 20
MEW	Ministry of Economic Warfare
MGB	motor gunboat
MI5	security service
MI6	synonym for SIS
MIR	Military Intelligence, Research
MLN	Mouvement de Libération Nationale
MMLA	Missions Militaires de Liaison Administrative
MO, MO/D	symbols, see pages 20, 22
MO ₁ (SP)	symbol, see page 13
MTB	motor torpedo-boat
MUR	Mouvements Unifiés de la Résistance
N	SOE Netherlands section
NAP	Noyautage de l'Administration Publique
NID (Q)	symbol, see page 13
OCM	Organisation Civile et Militaire
OG	Operational Group
ORA	Organisation de Résistance de l'Armée
ORB	Operational Record Book
OSS	Office of Strategic Services

OT	Organisation Todt
PCF	Parti Communiste Français
PE	plastic explosive
PF	personal file
PLM	Paris–Lyons–Méditerranée
PTT	Postes, Télégraphes, Téléphones
PWE	Political Warfare Executive
RF	SOE gaullist section
RSHA	Reichssicherheitshauptamt
SAP	Service d’atterrisages et parachutages
SAS	Special Air Service
SCAEF	Supreme Commander, Allied Expeditionary Force
Sd	Sicherheitsdienst
SD	Special Duties
SFHQ	Special Force Headquarters
SFIO	Section Française de l’Internationale Ouvrière
SHAEF	Supreme Headquarters, Allied Expeditionary Force
SHAT	Service d’Histoire des Armées de Terre
Sipo	Sicherheitspolizei
SIS	Secret or Special Intelligence Service
SMG	sub-machine-gun
SNCF	Société Nationale des Chemins-de-fer Français
SO	symbol, see page 17
SOE	Special Operations Executive
SOE/SO	symbol, see page 31
SO 1, 2, 3,	symbols, see pages 11, 19–20
SPOC	Special Projects Operations Centre
SSRF	Small Scale Raiding Force
SR	Service Renseignements
SS	Schutzstaffel
STO	Service du Travail Obligatoire
STS	Special Training Schools
T	SOE Belgian section
tr	translated (by)
V/CD	symbol, see page 19
WAAF	Women’s Auxiliary Air Force
W/T	wireless telegraphy

X	SOE German section
ZL	zone libre
ZNO	zone non-occupée
ZO	zone occupée

Note. Many other abbreviations will be found in the footnotes: AD/P, D/CE.G, FM, etc. All are the personal symbols of SOE staff officers, which the reader need not trouble to unravel. HS8/905–9 covers the rest.

Introduction

The full tale of French resistance is an epic, a Homeric study that still awaits its Homer. This book makes no attempt to go over it all. It is written in warm admiration for the achievement of the French people, whose own efforts in the struggle to set France free will remain, so long as men read the history of Europe, among its most splendid pages. Nor is the book meant to make invidious comparisons between different bodies of brave men and women. It seeks simply to record the contribution to French resistance of a single important organisation, SOE, and especially of a single section of it, F section. SOE has suffered from too little publicity of the right sort, and from too much of the wrong; these pages are meant to restore the balance. As this is a long and in places a complicated book, this introduction essays to place its subject-matter in historical context.

SOE, the Special Operations Executive, was an independent British secret service, set up in July 1940 and disbanded in January 1946.¹ Its main business was the ancient one of conducting subversive warfare. The middle 1930s had found the British with no machinery for running this at all. Section D of SIS, a small sub-department of the Foreign Office, called EH, and one of the War Office – originally called GS(R) – were set up in 1938 to investigate it. Their staffs expanded when the war began; the effects of their work were yet to come. The forming of Churchill's coalition government in mid-May 1940, the evacuation of most of the British expeditionary force from Dunkirk in the first days of June, and the French surrender on the 22nd brought on a complete rebuilding of British strategy and the British war machine; early in the rebuilding, the three sub-departments were fused to form SOE. (One of them was soon detached again, as the Political Warfare Executive, or PWE.)

SOE's task was to co-ordinate subversive and sabotage activity against the enemy; even if necessary to initiate it. In every German-occupied country

there were spontaneous outbursts of national fury at nazi rule. SOE's objects included discovering where these outbursts were, encouraging them when they were feeble, arming their members as they grew, and coaxing them when they were strong into the channels of greatest common advantage to the allies. Its scope extended the world over. We are concerned in this book only with what it did in France.

France was radically re-organised by the June 1940 armistice. All of it north and west of the demarcation line (marked on Map I) was occupied by German forces. The *Etat Français*, which Marshal Pétain set up to replace the third republic, was run from Vichy; Paris, in the occupied zone, was reduced to a provincial administrative centre. Four days before the armistice was signed, more than four weeks before SOE was formed, one junior French general had the courage to proclaim over the BBC that he did not accept the surrender, and to invite those of his compatriots who agreed with him to join him in fighting on. Charles de Gaulle's eventual stature recalls another Charles the Great who once ruled Gaul; but it took him many years to reach it. With truly heroic integrity, he stood out on the path that seemed to him the only path of honour. Four years after this first, tremendous gesture, millions of Frenchmen and Frenchwomen were ready to welcome him as their political saviour, but he began alone. Moreover, once he had collected some helpers he met a disaster which long dogged him. In September 1940 he took a force to Dakar, with a British fleet to back him; but the secret of the expedition was supposed to have leaked out to Vichy, and the resulting humiliation was held in Whitehall to indicate that the discretion of the Free French was not to be relied on. An inner circle was already aware that the French insisted on using readily penetrable ciphers; this gave graver grounds for caution.

Nevertheless, de Gaulle persevered. Only he could foresee the impending polarisation of French opinion between Pétain and himself, and his eventual victory. While he was still hardly known, while Pétain's policies were still uncertain, the British government felt able to do no more than recognise de Gaulle as the leader of those Frenchmen who would continue to fight; and SOE was originally instructed to operate in France without him. Hence the 'independent French', or F section, one of the six sections of SOE actively engaged on working into France.

Four of these six need only passing introductory mention: DF, which ran escape routes; EU/P, which worked among Polish speakers; AMF, which operated for 20 months from Algiers in 1943–44; and the JEDBURGH teams (JEDBURGHS, unlike the rest, wore uniform) who were never meant to reach France till OVERLORD – the main invasion – began in June 1944. The remaining sections, F and RF, deserve more notice at once.

All F section's initial efforts to get men into France failed, though de Gaulle early sent some officers over on reconnaissance. In March 1941 half a dozen gaullist parachutists borrowed by SOE dropped to attack a target

in Brittany (operation SAVANNA); they missed it, but brought back so many indications of de Gaulle's popularity that SOE formed RF as a second main country section to work into France, specifically in co-operation with the gaullist headquarters. The rival, F section, remained apart; not anti-gaullist, simply independent. While de Gaulle's supremacy among leaders of resistance was still in doubt, F section had to have agents available to work with any others who might emerge. In the long run, many of F's agents became as strongly gaullist as anybody else. Of course there were jealousies between F and RF sections, just as there were between SOE as a whole and other secret services. These jealousies were gradually resolved, as each came to accept the accomplished fact of the other's existence; in any case, they were always far worse in London than 'in the field'.

For in France, the two sections pursued different aims. RF's agents were nearly all French, and though they did some sabotage work – part of it highly distinguished – their principal concern was to trigger off an explosion of French opinion that would with allied help dispose at once of the Germans and of Vichy. Their orders were prepared for them jointly by de Gaulle's staff and by SOE's. SOE had a power of veto over these orders, though it was hardly ever used; and until 1944 the British had a virtual monopoly over all de Gaulle's means of communication with France except by wireless. F section's objectives, more limited than RF's, were laid down by SOE's higher command to suit outline directives from the British chiefs of staff. Most F agents were not French citizens. Most of them were sent to France to assist the eventual advance of the allied armies by specific demolitions. Some went to perform particular tasks of industrial sabotage; a field in which F section's record compares favourably with that of the much less economical RAF bomber command. Inevitably, some of F's best men ranged far outside a narrow saboteur's brief. For they found on the spot that they could best secure their set tasks by making themselves the generally accepted resistance leaders in whatever part of France their work lay. Many of F's circuit organizers were in fact spokesmen lodged in German-held territory for the allied governments, and specifically for the British. By force of character and example they imposed their will on the resistance activities of many thousands of the French.

There are various questions any reader of their adventures is likely to ask. Who did the agents think they were? What did they think they were doing? What part did they intend to play in the remaking of France? By what right did they attack property that was not theirs? Though the answers to all these questions are implicit in this book, it is worth setting some of them down explicitly now. All SOE's agents were enemies of the one enemy, Hitler. All had volunteered for tasks they knew to be dangerous, and to lie outside the boundaries of conduct set by international law for normal times and normal wars. All came, ultimately, under the direction of the British – or, later, the allied – chiefs of staff. All agreed with the chiefs of staff that

the times were not normal, and that special operations were essential to combat the iniquity of the one enemy and his system. Their motives were as diverse as their origins; but with few exceptions they were patriots – British, French, Polish, Canadian, or American – rather than adventurers or knaves. A few, again, had specific French political objectives, ranging from the far right to the far left. Yet most of the non-French agents knew little of French politics and cared less; and when they had a political aim at all, beyond helping in the overthrow of Hitler and Pétain, it was simply that of the British War Cabinet: to give the French every chance of a quite unfettered choice of their own system of government once the war was won.

The gaullists were well informed, through their own intelligence channels – which by arrangement the British read, but did not control – about some of the more dominating F agents, and could hardly help being suspicious. To the gaullists, the question of who was to be in power in France after the Germans had been driven out² was always *the* question; and they necessarily mistrusted bodies of armed men at large in France of whose allegiance they were uncertain. How little foundation there was for their suspicion the narrative will show. F section did get in touch with two sizeable groups of resisters whose tone was decidedly anti-gaullist, the followers of Girard and of Giraud – two characters as different as their names are alike; neither group proved fit to lie in the line of battle, and F dropped both.

Nor did F ever get far in its dealings with the French communists. That party's position for the first year of German occupation was equivocal, viewing the Russo-German pact that was then in force. The German attack on the Soviet Union on 22 June 1941 brought equivocation to an end, and thereafter the communists did their best to dominate resistance. Several important F agents were in touch with them, and they took such arms through F's channels as they could get. But it suited their political book best to come to terms with de Gaulle, and they did so; no doubt with many private reservations on each side. This was a passage in French politics that SOE could do little more than observe.

A less narrowly political consequence of the German aggression on Russia was that France's situation did not seem quite as hopeless as before to the French. And when within six months Germany had declared war on the USA as well, an eventual allied victory could be relied upon. The early part of 1942 was almost as gloomy for the enemies of nazism as the summer of 1940; but at last the tide of the war turned at Midway, Alamein, and Stalingrad.

America's weight on the allied side was decisive; but it was not at first thrown behind de Gaulle, because of the personal accidents that Roosevelt did not like him at all, and that many high authorities in the state department detested him.³ The Americans maintained friendly relations with Vichy as long as they could, and tried at the end of 1942 to govern French Morocco and Algeria – overrun by TORCH – through Pétain's deputy

Darlan, who happened to be there at the time. Darlan's assassination soon brought this scheme to nothing, and the Americans fell back on the recently escaped General Giraud as their favourite French leader. These attempts made de Gaulle more determined than ever to assert his independence and supremacy. He moved his headquarters from London and set up the French committee of national liberation at Algiers, with Giraud among its members. In fifteen months' austere and astute political manoeuvre, watched with fascination by Harold Macmillan the British Minister-Resident in Algeria, de Gaulle not merely outwitted but outclassed Giraud, who retired in the spring of 1944; this left de Gaulle in control of the Free French movement.

Events within France had justified him by then. In reply to TORCH the Germans occupied the hitherto 'free' two-fifths of Vichy France; this brought the war right home to the whole French population. So did the scheme for forced labour in Germany by all Frenchmen of military age, introduced in the second half of 1942. This *Service du travail obligatoire* triggered off the maquis, the groups of young men who fled to the hills to escape the horrors of the labour camps. For many of these maquis RF section was eventually able to organise important supplies, mainly of parachuted arms; and from some of them F section was able to mount important little expeditions to harass enemy movements in the summer of 1944. By this time the great bulk of the French adult and adolescent population had accepted de Gaulle as the man in whose name they wanted the Germans thrown out, and readiness to follow his directives was common ground among F and RF agents in France. None of the intriguers and backbiters had stayed the course; nor had the merely honourable men, the old men without fire. De Gaulle, first in the lists of resistance, was still there.

But distrust of him still prevailed in the highest reaches of the western allied command: a distrust that stemmed from Dakar and from doubts about cipher security and had been fed by many more or less trifling incidents since. Consequently, the Free French were shut out from the planning of OVERLORD. They could not believe their exclusion stemmed from fears of their security, and imputed worse motives, such as a sinister scheme to keep Pétain in power. RF's staff was almost equally shut out from what was being prepared, as indeed were all the country sections of SOE. The gaullists beavered away at their own plans, irrespective of the prospects of putting them into action. As de Gaulle's price for extruding Giraud had included taking numerous giraudist regular officers on to his own staff, some of these plans were far out of touch with the realities of life in occupied France.

De Gaulle proclaimed in March 1944 the existence of the FFI, and created a staff for them (EMFFI) under Koenig, one of his best fighting generals. When OVERLORD did begin, the allies decided to entrust to EMFFI full authority over French resistance, F section's circuits and the JEDBURGH teams included. Koenig assumed this new command on 1 July. Formed at the height of a battle by an amalgam of the staffs of RF and F sections and of

the London gaullists, EMFFI had no chance to perform prodigies of staff work; about it there hung an inescapable flavour of that motto of amateur theatricals, 'It'll be all right on the night'. So it proved: the resistance groups that SOE nurtured had secured over a thousand interruptions of rail traffic in a single June week. They then rendered the Germans' rear areas insufferably perilous to the enemy, and kept eight divisions permanently away from the battlefields of OVERLORD and DRAGOON, engaged in unsuccessful attempts to hunt them down. De Gaulle's administrators had no trouble in picking up the reins of government Pétain's men laid down as town after town was liberated; though they continued to look askance at the surviving F agents and sub-agents who had helped them into power.

By the time they lost France, the Germans had bundled into their concentration camps some scores of thousands of French resistance workers, including about two hundred agents trained by SOE for work in France. Of these last, fewer than forty returned to recount what they had been through. The best justification for the war and all its losses is that it destroyed the regime which let these camps exist.

Analytical Table of Contents

Part I: Structure

I	The Origins of SOE	3
	Sections EH, D, and GS(R) founded, 1938; inter-departmental rivalries, overshadowed by French disaster; sections fused to form SOE, July 1940. EH separated to form PWE, 1941.	
II	What SOE Was	13
	Cover; daring; range; strength. Constitutional status. MEW; CD. Country sections: DF, F, RF. Gaullist arrangements: BCRA. Council. Staff diagrams.	
	Relations with Foreign Office; chiefs of staff; Americans; Russians; French – EMFFI; other secret services. Location.	
III	Recruiting and Training	41
	Recruiting haphazard – army cover – casualties – decorations – pay – man- and woman-power. Staff homogeneous; agents miscellaneous.	
	Training by subjects: preliminary, para-military, and security – special schools – ‘amateurs’ and ‘professionals’ – weaponry – holding schools.	
IV	Communications	59
	Cardinal importance	
	(a) Sea	60
	Beaches – craft – competitors – Mediterranean problems – VAR escape line.	

(b) Air	71
Strategic focus, Parachute air lift – techniques and casualties – stores packing – reception committees – radio aids – aircraft casualties. Clandestine pick-ups – Lysanders – some 700 passengers carried, 550 of them for RF section – reception drill.	
(c) Land	87
Dullness – safety rules – smugglers and quacks – frontier crossings.	
(d) Signal	94
Wireless indispensable – attracted enemy direction-finders – codes and ciphers – other security precautions – transmission errors. Code messages also passed by BBC.	
(e) In the field.	103
V Security in France	106
Abwehr and SD, overlapping rivals – French police less uniformly hostile, except for <i>milice</i> . Best SOE agents taciturn – and lucky. Language difficulties – weak prisoners – but no ‘traitor in Baker Street’.	

Part II: Narrative

VI Politics and the Great Game	119
SOE a revolutionary force. 1940 offer of Anglo-French union refused. French right backed Pétain; left was discredited. De Gaulle emerged as the one serious alternative, but slowly; French only gradually accepted need to resist. Germans their own worst enemies. De Gaulle’s character. Role of British officers in France on SOE’s business – their popularity – their isolation from French politics. Official British aim simply to re-establish a free French state, fully independent. Till de Gaulle’s eventual predominance was sure, F section’s roles included watching out for alternatives – EMFFI in the end incorporated F and RF alike, and many F agents were strongly gaullist in sympathy.	

SOE's tasks its own, yet much overlapping with other services. French support vital; nearly half France thought, with some truth, that it freed itself. Value of SOE's efforts to assist, particularly through 93 F circuits and through RF's articulation of resistance on a national scale.

VII Opening Gambits: 1940–41

136

Slow start. Distinction between coups de main and preparation of secret armies. Early F failures in Brittany. SHAMROCK raid on Lorient November 1940.

Importance of gaullist failure at Dakar. Gaullists wanted circuits to snowball, SOE did not.

SAVANNA (March 1941) and JOSEPHINE (early June) showed possibilities; German attack on USSR widened them.

Bégué dropped for F, 5/6 May 1941. De Vomécourt brothers founded AUTOGIRO. COS agreed to form special duties RAF squadron. Minor RF operations.

De Guéllis' liaison mission – Virginia Hall at Lyons – Cowburn reconnoitred oil – most of a dozen fresh agents arrested, including all wireless operators – AUTOGIRO imbrangled, unknowingly, with Abwehr.

Jouhaux incident – Buckmaster replaced Marriott, November.

VIII Development: 1942

163

Jean Moulin, de Gaulle's delegate-general in France.

SOE and COHQ – Small Scale Raiding Force – no contact with resistance – Hitler's reprisal orders. Other small sections' work: EU/P's ADJUDICATE, DF's VIC.

AUTOGIRO and *La Chatte* – Pierre de Vomécourt arrested – Burney and Grover-Williams.

COS directive: co-ordinate patriot action.

New F circuit in Loire valley – Suttill (*Prosper*) – de Baissac at Bordeaux.

Philippe de Vomécourt active in ZNO – Mauzac escape. Girard's CARTE – more promise than performance – split asunder at end of year. Confusion round Lyons, resolved by Boiteaux; and in Marseilles. Brooks founded PIMENTO among southern railwaymen.

TORCH – Darlan incident – Germans occupied ZNO – missions of Biéler, Trotobas, and Antelme in ZO began.

RF less successful. OVERCLOUD broken up. BOA and SAP started up. Some sabotage missions. De Gaulle in touch with PCF; Moulin and Morandat co-ordinated resistance

nationally. Still many doubts about de Gaulle in London – staff wrangles.

IX Middle Game: 1943

209

COS directive: organize resistance groups. Tide of resistance began to rise – crises about air lift – COSSAC's role.

CNR set up by Moulin, Dewavrin, and Brossolette – Caluire arrests, June – British insisted on decentralisation, gaullists resisted it – Anglo-French coding dispute – MARIE-CLAIRE mission (Brossolette and Yeo-Thomas) kept gaullist command system in being.

ARMADA, brilliant team of RF canal saboteurs.

F's work. Frager's DONKEYMAN entangled with Abwehr – Cammaerts' JOCKEY securely set up in Rhône valley – Skepper's sketchier MONK on Riviera. Suttill's PROSPER flourished round Paris and down Loire, with many sub-circuits, till June. Three failures in Brittany. Liewer's SALESMAN active on lower Seine. Trotobas (*Michel*): success and defeat at Lille. Cowburn effective at Troyes (TINKER). SPINDLE (Peter Churchill) and PRUNUS (Pertschuk) broken reeds; PIMENTO (Brooks), because more cautious, flourishing. SCIENTIST (de Baissac) disrupted by Grandclément, leaving AUTHOR (Peulevé) as a healthy offshoot.

Maquis grew in remote areas. Southgate's STATIONER and George Starr's WHEELWRIGHT strong in central France and Gascony respectively; other good groups near Lyons. Rée's STOCKBROKER introduced 'blackmail sabotage'; Helsop's MARKSMAN developed Jura.

X A Run of Errors: 1943–4

258

(1) FARRIER, Déricourt's Lysander circuit – details of operations – Germans shadowed many arrivals – organizer's loyalties dubious – his post-war trial and acquittal – *Toinot* incident.

(2) PROSPER circuit snowballed – agents too careless – circuit correspondence read by enemy. Lines crossed with NORTH POLE the Abwehr coup in Holland. Double indiscretions, in London and Paris, brought disaster; an important agent defected; several hundred arrests. Contrast the heroism of Agazarian or Grover-Williams, or of Gerson's vic line which survived a NORTH POLE penetration.

(3) Consequential 'radio games' – Germans failed to work back PROSPER'S wireless, but cunningly exploited ARCHDEACON,

a wholly fictitious Canadian circuit and BUTLER (Garel and Rousset); and PHONO (Garry and Noor Inayat Khan). Captured operators' gallantry ineffective owing to errors in London – money, arms, and men dropped to penetrated circuits. In April 1944 British detected deception and turned tables – some powerful circuits set up unknown to Gestapo. Almost all captured agents liquidated; yet risk had to be taken.

XI Pressure Mounting: January–May 1944 309

Sabotage effort needed to coincide with invasion. Aircraft availability crisis. Less than 100,000 French armed by midwinter.

French preparing conservative plans – leadership crises – Brossolette's death – RF's network of DMRs – FFI set up (March).

F's network of 40 current circuits equally dense. Northeastern France (Biéler, Dumont-Guillemet); MARKSMAN survived Glières fighting; Lyons circuits and JOCKEY survived German offensive. WHEELWRIGHT and others busy in south-west. Maingard, Pearl Witherington, de Baissac, and Philippe de Vomécourt active in Limousin, Berry, and south Normandy. Disputes about eventual French treatment of F agents.

XII A Run of Successes: June–September 1944 339

EMFFI set up – Churchill quarrelled with de Gaulle. French national uprising, moving far faster than SOE's plans under stimulus of invasion. 950 SOE rail cuts on 5/6 June.

Vercors disaster, due to faulty guerilla tactics. Savoyard and Auvergnat maquis did far better, imposing important delays on German columns – several circuits held up an SS Panzer division on way to Normandy for a fortnight.

Polish BARDSEA plan – JEDBURGH teams busy – OGs – *missions interalliées* – SAS brigade – conquest of Brittany – tactical intelligence parties.

Casualties to F agents, women especially – DRAGOON's success hinged on resistance help. Liberation of Paris.

Prise de pouvoir by gaullists.

XIII Aftermath 368

Gaullist *commissaires de la république* – quarrels with Starr and others – end of clandestine operations. Anglo-French amity, fostered by SOE, let drop by Governments.

Most arrested agents butchered in concentration camps.

XIV Strategic Balance Sheet

380

SOE's strategic economies not fully exploited.

Moderate direct successes with sabotage; large indirect gains through diversion of enemy forces. Preliminary comparisons with RAF bomber command suggest SOE a more efficient as well as a cheaper means of destroying both material and morale.

OVERLORD and DRAGOON substantially aided by SOE's incessant interference with German lines of communication – Eisenhower and Maitland Wilson concurred – French popular support the indispensable base.

US policy much more anti-gaullist than British – USSR ordered French communists to co-operate with de Gaulle, for party advantage. SOE's role in securing continued French freedom of choice.

OR 6088
FRANCE
AND LOW COUNTRIES

SCALE 1:233,000 OR 46.5 MILES TO 1 INCH
MILES 50 40 30 20 10 0 50 MILES

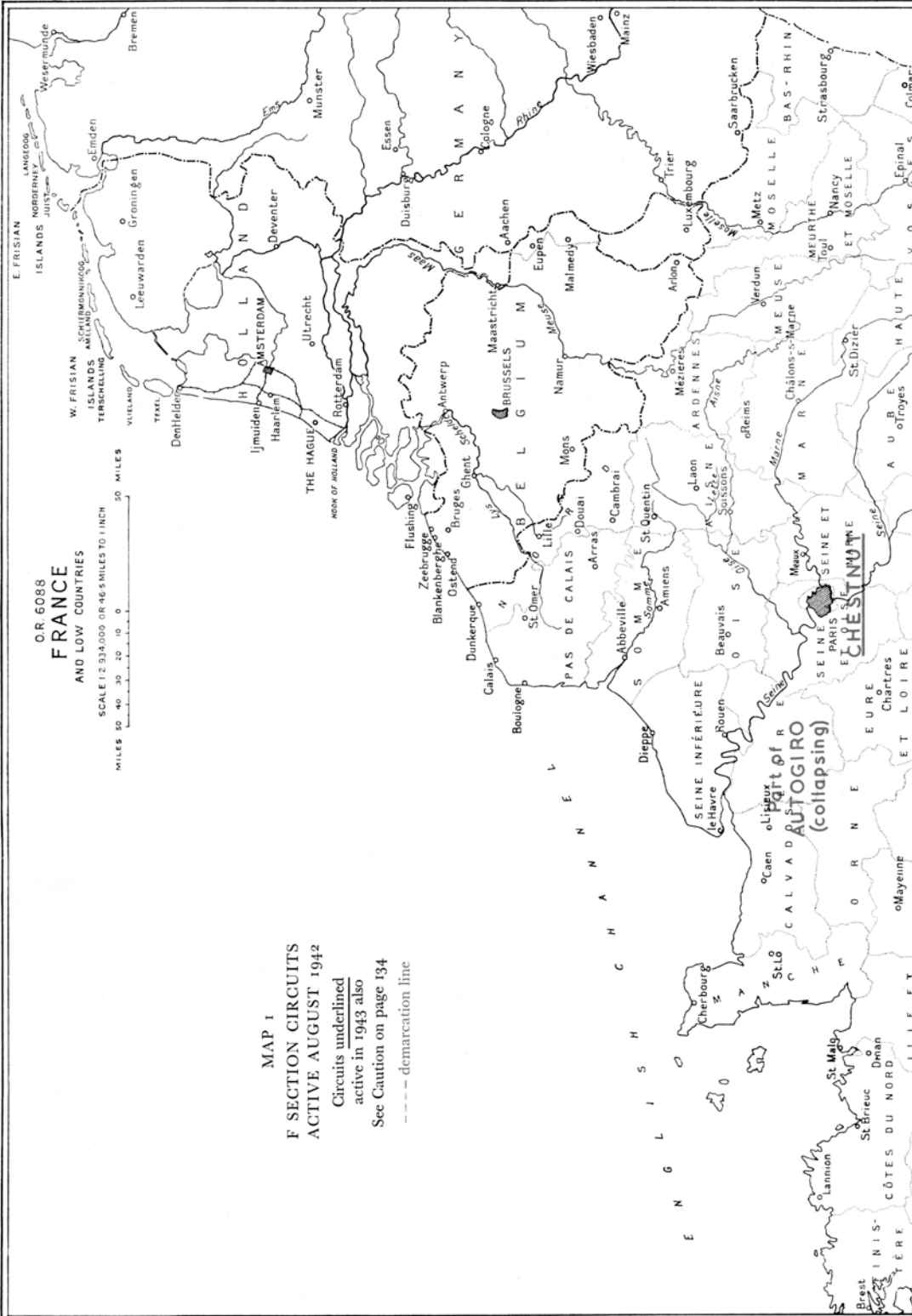

MAP 1
F SECTION CIRCUITS
ACTIVE AUGUST 1942
Circuits underlined
active in 1943 also
See Caution on page 134
---- demarcation line

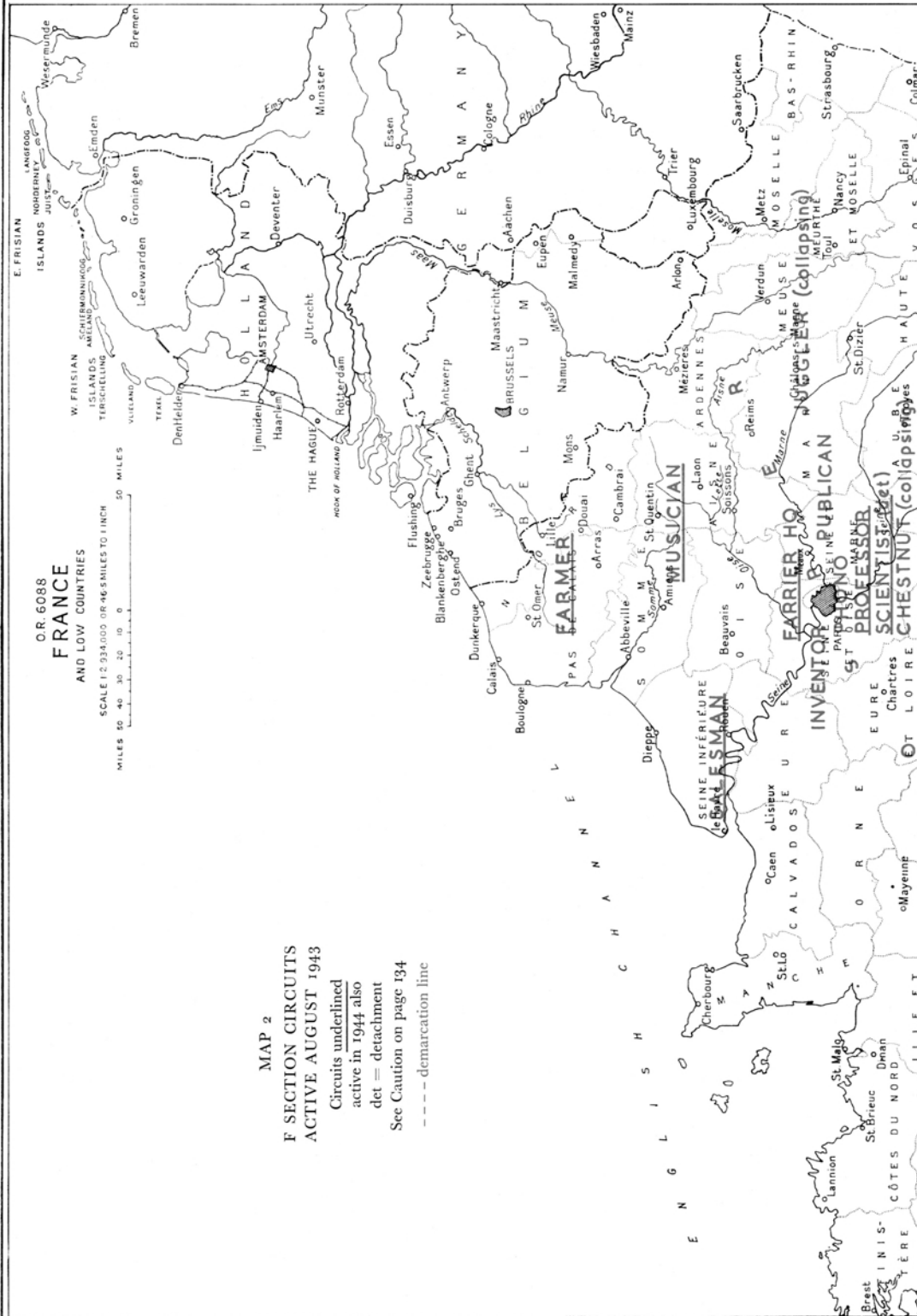

MAP 2
 F SECTION CIRCUITS
 ACTIVE AUGUST 1943
 Circuits underlined
 active in 1944 also
 det = detachment
 See Caution on page 134
 --- demarcation line

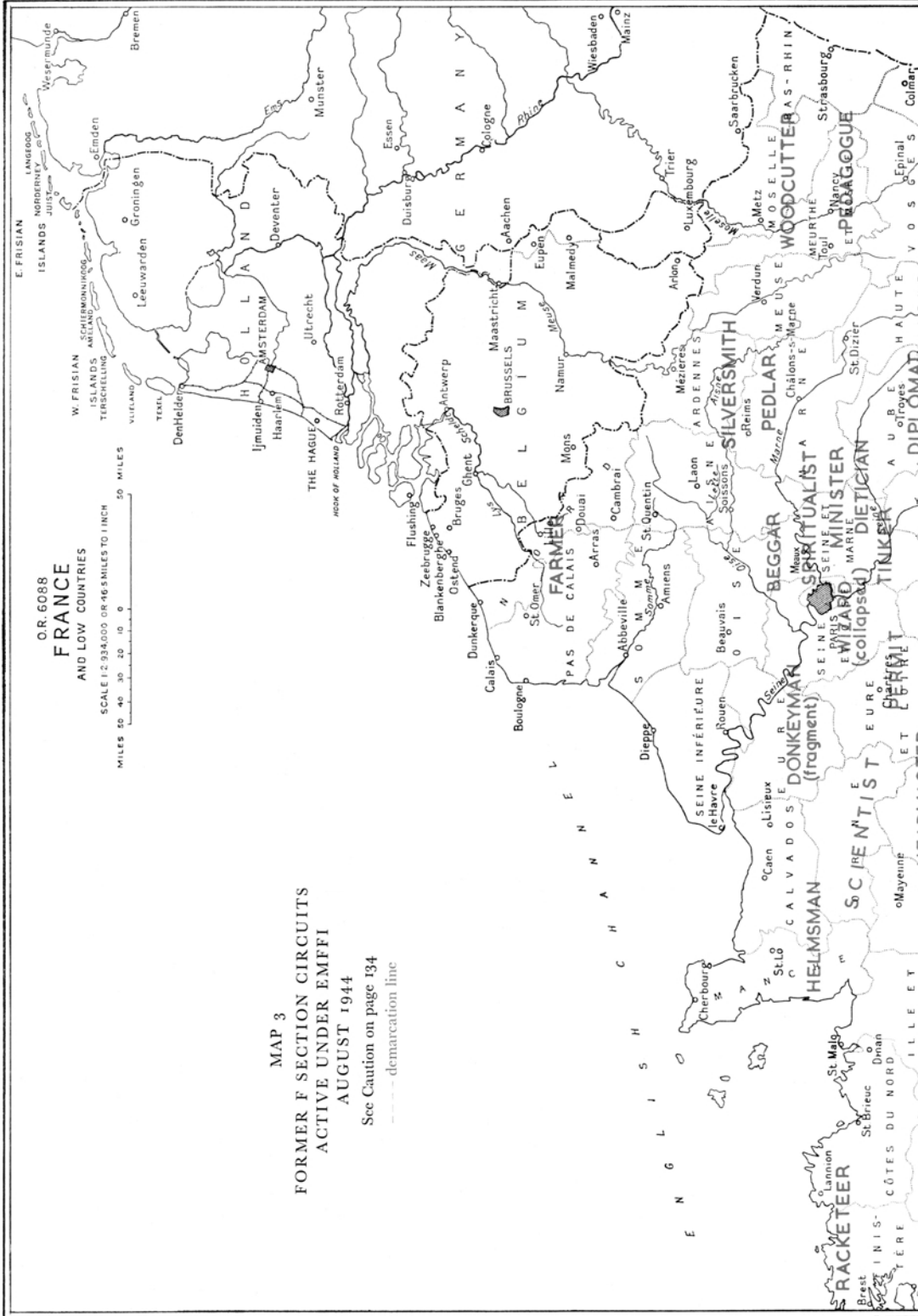

MAP 3
 FORMER F SECTION CIRCUITS
 ACTIVE UNDER EMFFI
 AUGUST 1944
 See Caution on page 134
 --- demarcation line

OR. 6088
FRANCE
AND LOW COUNTRIES

SCALE 1:2,934,000 OR 1/46.5 MILES TO 1 INCH

MILES 50 40 30 20 10 0

MAP 4
UNIFORMED PARTIES BEHIND
THE LINES, JUNE-SEPTEMBER 1944

- J = JEDBURGH team
- M = interallied mission
- O = operational group
- S = SAS party
- Arrowed line = SAS operation WALLACE

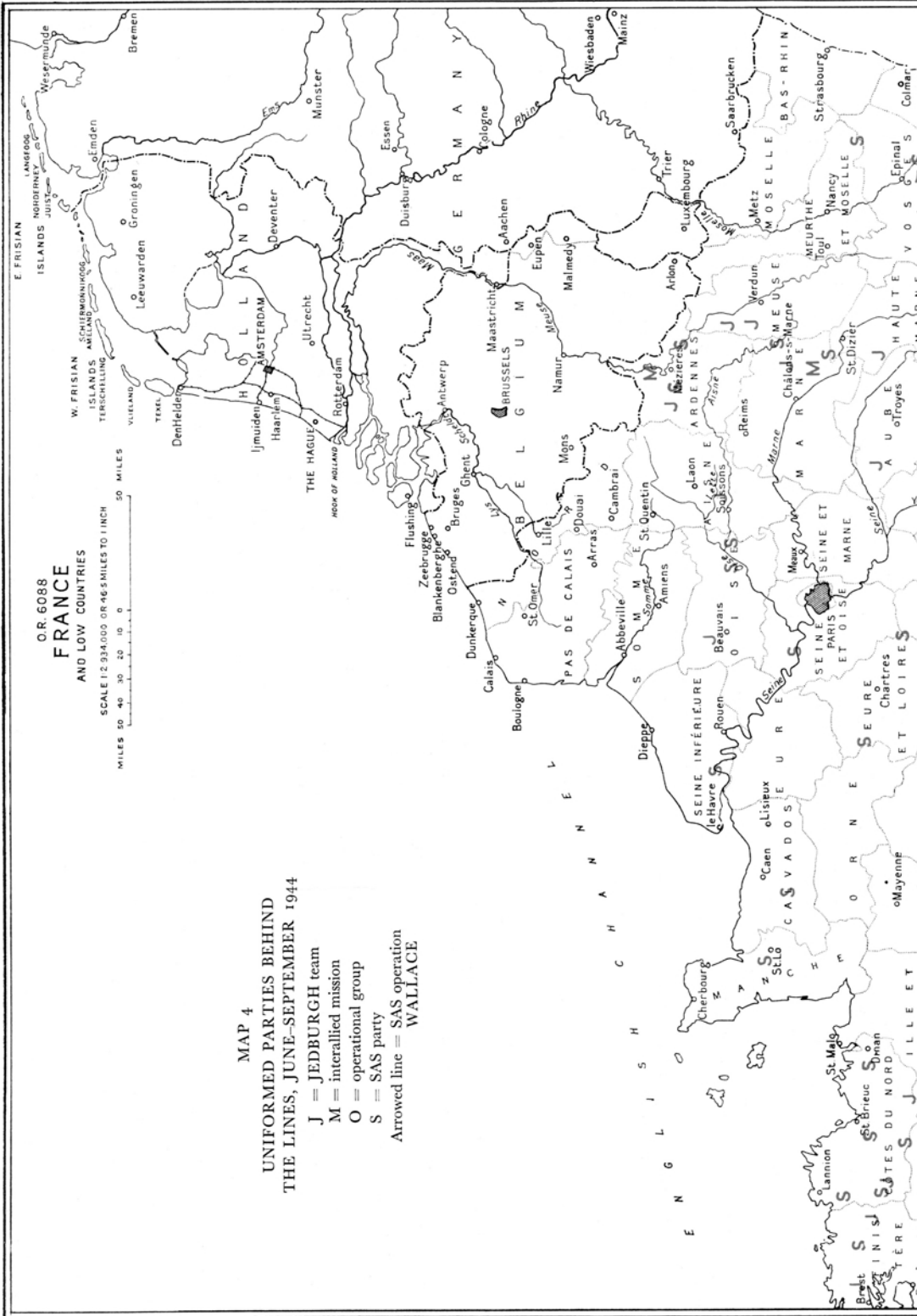

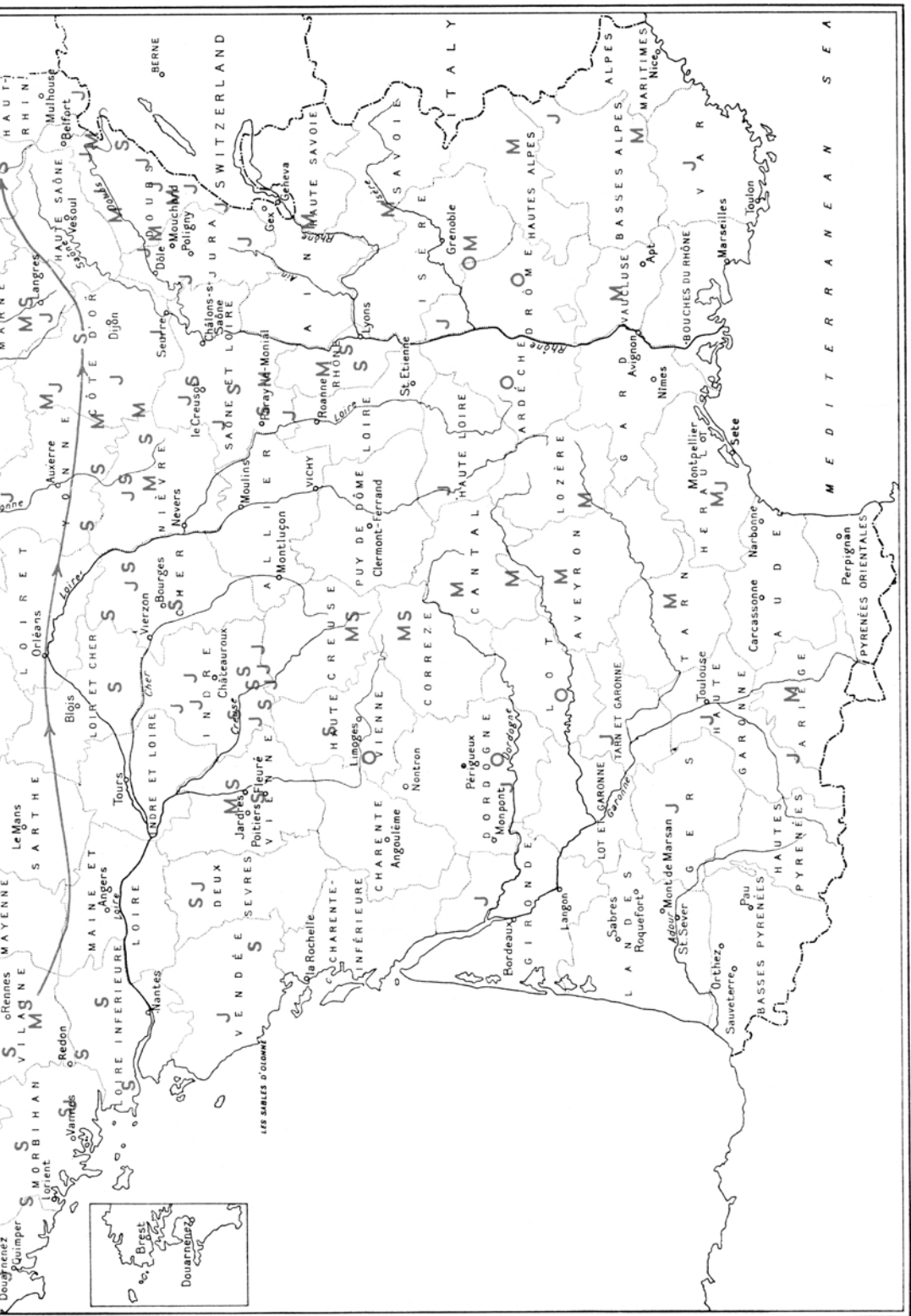

MEDITERRANEEAN SEA

Part I
Structure

I

The Origins of SOE

The great war of 1939–45 was fought to decide whether national socialist Germany was to dominate the world or not. The nature of the nazi dictatorship gave Germany's neighbours some warning of their impending doom, though most of them took little notice. The nazis, resembling in this the communists, made no secret of their belief in force as the ultimate political solvent; they set a fashion for subversive activities in countries they proposed to conquer which defied the Queensberry rules of international conduct that staid powers had recently observed. This again debased the standards of how countries ought to behave to each other; however reluctant, these powers had to join in the new fashion or succumb.

In March 1938, when Hitler's annexation of his Austrian homeland made imminent danger plain, the British began afresh to turn some official attention towards irregular and clandestine warfare. Clandestine operations are probably quite as old as war, if not quite as respectable; the Trojan horse provides the classic example. The English and Scots had frequently been involved in them as victims and as stimulators: corrupting the allegiance of French feudal lords in the fifteenth century, resisting the encroachments of Catholics inspired from Spain in the sixteenth, holding down Ireland against French infiltration in the seventeenth and eighteenth; flooding revolutionary France with forged assignats in the 1790s; subverting the loyalty of Indian, Afghan, and Egyptian princelings to build the first and second British empires; enduring German-inspired sabotage of munition ships and the German-aided Irish rising in 1916. But by 1938 the days of irregular warfare as a normal tactic of imperial expansion and defence were past, and half forgotten; no organization for conducting it survived, and there was no readily available corpus of lessons learned or of trained operators in this field. T. E. Lawrence's exploits in Arabia, one of the last irregular British armed offensives, had become a romantic legend even before his accidental

death in 1935. Several of his colleagues survived, all over forty-five; but the body that had directed them – MO4, GHQ Cairo – was in abeyance. In any case, it had been part of a subordinate headquarters; what was needed was study at the centre.

The need was partly met by three bodies, set up by different authorities in 1938 and overlapping with each other. Late in March the Foreign Office launched a new internal department, sometimes called 'EH' and sometimes 'CS' after Electra House on the Thames embankment where its head Sir Campbell Stuart had his office. Stuart had been prominent under Northcliffe in propaganda to the enemy in the previous war; his new organisation was to look into methods of influencing German opinion, and formed the nucleus of the eventual Political Warfare Executive.

The second body looking into the subject was somewhat less cramped in by the departmental machine. It was set up simultaneously with E H; it was a new branch of SIS, at first called section IX, then renamed Section D (presumably for Destruction). Its purpose was defined thus: 'To investigate every possibility of attacking potential enemies by means other than the operations of military forces.'¹ 'Examining such an enormous task', its head said years afterwards, 'one felt as if one had been told to move the Pyramids with a pin'.² His charter meant in practice that the section was to consider – not, in peace-time, to employ – means of injuring targets vulnerable to sabotage in Germany; to look into the sort of people who might be persuaded to attack them, such as communists or Jews; and to consider 'moral sabotage', a term shortly extended to cover propaganda. Work on propaganda overlapped of course with the tasks of Electra House; as work on sabotage devices overlapped with the work of the third body looking into subversion.

This was the research section of the general staff at the War Office, originally known as GS (R). To call it a section overstates its early strength, for it began with a single GSO 2 who reported direct to the VCIGS, and a typist. The first incumbent worked on army education. By a lucky accident, he was succeeded late in 1938 by J. C. F. Holland, an engineer major whose war service had included some flying in the near east in 1917–18 and some time in Ireland during the Troubles, in which he was badly wounded. His health never fully recovered, and a friend in high quarters secured him this sedentary work which would let him follow his own bent. Impressed by recent events in China and Spain, he chose for his subject of research the possible uses of guerilla in future wars; this led him to study light equipment, evasive tactics, and high mobility.³ His subject's importance should have been obvious to the British, for in 1899–1902 it had taken a quarter of a million men to put down an informal Boer army less than a tenth as large; and twenty years later an Irish irregular force with arms for fewer than three thousand men had baffled the efforts of some eighty thousand troops and armed police to counter it. Holland soon became a strong contender for preparations for irregular operations of all kinds. Equal support for them,

equally imaginative, came from the deputy director of military intelligence, Beaumont Nesbitt. Neither could make much headway against the traditionally hidebound directorate of military operations, which ran between the blinkers of King's Regulations and Army Council Instructions; even while Pownall held jointly the posts of DMO and DM1.⁴

To anticipate for a moment, a technical sub-section under Holland headed by (Sir) M. R. Jefferis later did a good deal of productive research, including the invention of two weapons familiar in England in the summer crisis of 1940: the 'sticky bomb' or ST grenade, a hand anti-tank weapon usable by brave men,⁵ and the 'Blacker Bombard', a light anti-tank mortar named after its ingenious and assertive inventor. Blacker and Holland were much taken with the possibilities of helicopters or very light aircraft, as vehicles for a new kind of light cavalry; but these possibilities then remained on paper.⁶ Section D's technical experts were mainly busied in devising time fuses for incendiary and other explosives; their work on these was valuable, and over 12 million pencil fuses of their design were manufactured during the war.⁷ These were based partly on a German design of 1917, partly on models provided by the Poles in 1938 and 1939.

Holland and Grand, the head of section D, kept in close touch, and worked out an informal division of labour; GS (R) would concentrate on the whole on actions for which the government could if pressed accept responsibility, while section D handled the unavowable. Between them they prepared a paper which D put up to Gort, the CIGS, on 20 March 1939; and a meeting to discuss it was held in the Foreign Office three days later. Halifax and Cadogan, the Foreign Secretary and Permanent Under-Secretary, were present; so were the CIGS, Grand, and Grand's official superior, C. They agreed that, subject to the Prime Minister's approval, a few active preparatory steps could now be taken in deadly secrecy by section D, to counter nazi predominance in small countries Germany had just conquered or was plainly threatening.⁸ There is no trace of Chamberlain's opinion, though his approval can be assumed. By this decision SOE was begotten; but the child was long in the womb.

Holland followed in securing Gort's approval for an extension of his work, and for another GSO II to join him. On 13 April 1939 GS (R) was authorised 'To study guerilla methods and produce a guerilla "F[ield] S[ervicel R[egulations]"' – the contradiction in ideas is eloquent; 'To evolve destructive devices ... suitable for use by guerillas'; and 'To evolve procedure and machinery for operating guerilla activities, if it should be decided to do so subsequently'.⁹ Brisk study brought the conclusion on 1 June 1939 that if 'guerilla warfare is co-ordinated and also related to main operations, it should, in favourable circumstances, cause such a diversion of enemy strength as eventually to present decisive opportunities to the main forces'.¹⁰ By that time, a brief substitute for a guerilla FSR had been written, in three short pamphlets, two of them by the new GSO II, (Sir) Colin Gubbins. Like

Holland, he had fought on the losing side in the Anglo-Irish war of 1919–21; he had also seen a few months' service in Russia in 1919. He had been impressed by the weakness of formed bodies of troops faced by a hostile population that was stiffened by a few resolute gunmen, and determined to exploit these impressions against the next enemy. His first pamphlet, *The Art of Guerilla Warfare*, was a commonsensical treatise on theory; it stressed, for instance, the needs for a friendly population and for daring leadership. Even at this primitive stage, it is worth noting that research into recent Russian, Irish, and Arab history led Gubbins to conclude that 'Guerilla actions will usually take place at point blank range as the result of an ambush or raid ... Undoubtedly, therefore, the most effective weapon for the guerilla is the sub-machine gun'; an armament policy eventually pursued by SOE, not always with happy results.¹¹ *Partisan Leader's Handbook*, a companion booklet, was written for a more popular readership to cover such practical points as how to organise a road ambush, how to immobilise a railway engine, and what to do with informers (kill them quickly).¹² In the third work, also very short, Jefferis gave a clear sketch of *How to Use High Explosives* to any intelligent and nimble-fingered layman in the arts of small-scale demolition. Much use was made of this later; it was kept up to date, translated into several languages, and widely distributed by air. Anyone interested in these practical details can see an amply illustrated French version of its contents published not long after the war.¹³

In the spring of 1939 GS (R) was renamed MIR, and became nominally part of the military intelligence directorate. For a few months Holland set up his still minute staff alongside section D's; but he seems to have believed D's head to be too visionary and impractical to suit the exigencies of the war that both he and Gubbins regarded as imminent. During the summer they and D held a few discreet training courses on the elementary theory of guerilla for selected civilians – explorers, linguists, mountaineers, men with extensive foreign business contacts – some of whom later had distinguished careers in SOE. Gubbins also made two secret journeys by air, one down the Danube valley and one to Poland and the Baltic states, to study the possibilities of guerilla action among Germany's eastern neighbours. On 25 August he left for Warsaw as chief of staff to the British military mission to Poland. A week later Holland broke away from proximity to D and returned to the War Office main building; for he had no faith that what he regarded as D's wildcat schemes would ever produce specific achievements.

Holland was both brilliant and practical; he was also quite unselfish. He saw MIR as a factory for ideas: when the ideas had been worked up to the stage of practicality, his aim was to hive off a new branch to handle them, not to keep them in an empire of his own. Early in the war he and his lively and enterprising staff launched several interesting and secret organizations, including the sizeable escape and deception industries and the commandos.

MIR was also one of the bodies from which SOE sprang. But for all its good men and good ideas, it had only slight actual achievements to display by the late spring of 1940: a useful small flanking action against German troops in Norway, and the destruction of several million pounds' worth of bearer bonds in Holland, just before the Germans arrived. Section D equally was so far able to show more promise than performance, save for the rescue of £1¼ million worth of industrial diamonds from under the Germans' noses in Amsterdam, in spite of multifarious activities and expansion to an officer strength of over seventy (Grand claimed twice as many) by July;¹⁴ and even more than MIR it had managed to antagonise a considerable number of established authorities, British and allied, whose help might have been of value had they been more tactfully approached.

Yet section D had already secured one achievement of weight, without which SOE could probably never have been brought to birth. Its head had managed to accustom a few very senior civil servants to the concept, until that time unheard-of to them, that there should be in London a highly secret government department that dealt in sabotage and subversion overseas.¹⁵ This was so vitally important for SOE's future that much could be forgiven the section that had managed to achieve it. Its leader, moreover, was a real inspiration to the people who worked under him. He gave them unbounded confidence, and just that élan which was indispensable for their work, particularly in its early stages – disagreeable and uncomfortable though such ardour was to many of the bureaucrats whose paths his officers crossed.¹⁶ Some of these officers later held positions of importance and influence in the clandestine war, and their wide-ranging inquisitive spirit infused and inspired many parts of SOE.

Each section had a few contacts in France, official and less official, and a small mission in Paris, where the deuxième bureau's attitude was later described as 'friendly but sceptical' to section D;¹⁷ scepticism, in retrospect, seems a reasonable attitude to a body that was deep in proposals to destroy the telecommunications of the southern Siegfried line through the agency of two left-wing German expatriates, one stone deaf and the other going blind.¹⁸ The MIR mission was to the Czechs and Poles, not to the French. It was headed by Gubbins till Holland withdrew him in April 1940 to take over the independent companies; his successor was Peter Wilkinson, a discovery from the first training course, who spent much of the rest of the war in responsible positions on Gubbins's staff and in enemy-held territory.¹⁹ No one in the French government or high command would so much as admit the possibility of the French collapse, until it came; hardly anyone on the British side was better informed. Someone in section D must have had some insight, for that body did manage to leave behind in northern France ten small dumps of sabotage stores, with two Frenchmen in charge of each, scattered over 150 miles between Rouen and Chalons-sur-Marne, with an eastern outlier at Strasbourg. But the prescience that posted them did not

extend to providing these 20 men with adequate orders or with a base of supply; for sabotage purposes they were therefore useless – no base, no achievement – and the survivors of them were eventually absorbed into escape lines.²⁰ MIR's Paris mission was not empowered to do anything at all; but the section, helped by an informal contact with the Admiralty, did carry out the first seaborne raid on France. This was a reconnaissance by three officers who landed from a trawler between Boulogne and Etaples on the night of 2/3 June, and returned – rowing for thirteen hours – on the 10th. One straggler picked up was the sole tangible benefit of what Churchill called a 'silly fiasco'; but this minute expedition did show that 'the idea of "mosquito" raids into enemy territory by small bands of picked men was possible'.²¹ While they were in France, on the 9th, an MIR subaltern carried out an important demolition at Gonfreville, by Harfleur; with the reluctant consent of the manager, and the help of a Very pistol, some improvised petrol torches, and half a dozen British soldiers, he ignited 200,000 tons of oil. The fire was still burning merrily four days later.²²

The crumbling of the land front in Europe precipitated a revolution in British strategic thinking. As early as 25 May 1940 the chiefs of staff submitted to the War Cabinet that if France did collapse 'Germany might still be defeated by economic pressure, by a combination of air attack on economic objectives in Germany and on German morale and the creation of widespread revolt in her conquered territories'. To stimulate this revolt, they added, was 'of the very highest importance. A special organization will be required, and plans ... should be prepared, and all the necessary preparations and training should be proceeded with as a matter of urgency': otherwise, 'we should have no chance of contributing to Europe's reconstruction'. On 3 and 5 June Beaumont-Nesbitt, now DMI, put forward papers from MIR that proposed a War Office directorate of irregular activities, with 'a measure of control' over EH and the more secret services, and liaison with the Admiralty, Foreign Office, and Air Ministry.²³ Eden, then in charge of the War Office, forwarded the scheme to the Prime Minister a week or so later;²⁴ but the scope available to such a single-service directorate was too small. Churchill by now was on fire with enthusiasm for irregular warfare, as for much else; with his weight in its favour, the scales began to tilt decisively towards establishing a single body to run it. He called in Hankey, the veteran co-ordinator of an earlier war, who in the sinecure office of Chancellor of the Duchy of Lancaster was acting as interpreter for each others' needs between the War Cabinet and the various clandestine organizations. On the evening of 13 June Hankey held a meeting with the heads of MIR and section D 'to discuss certain questions arising out of a possible collapse of France'.²⁵ They all agreed that something should be done to co-ordinate raiding and subversive activities under a single minister; and that Hankey should sound out the chiefs of staff informally. Two days later the directorate of combined operations was set up, under the Admiralty; the

Marine general who was its first head also pressed for some coordinating body, from a different angle.

But in that desperate summer the inter-departmental struggle for power that might have raged for years in peacetime was brought to a compromise in days. Nothing is recorded of Hankey's conversations, for no one was better at keeping a secret.²⁶ Common agreement on what to do emerged promptly enough in the service stratosphere; the last word remained with the politicians. Halifax called the decisive meeting in his room in the Foreign Office on 1 July. The others present were Hankey; Lloyd, the Colonial Secretary, an old friend of Lawrence's; Hugh Dalton, the Minister of Economic Warfare, who had for some days been pressing for a start on political warfare as well; Cadogan, with Gladwyn Jebb his private secretary; C, the head of the intelligence service; the DMI; and (Sir) Desmond Morton from Churchill's private office. A three-day-old paper of Cadogan's which leaned towards the DMI's plan provided the agenda. 'After some discussion of the multiplicity of bodies dealing with sabotage and subversive activities, there was a general feeling, voiced by Lord Lloyd, that what was required was a Controller armed with almost dictatorial powers'.²⁷ As Dalton wrote to Halifax next day,

We have got to organize movements in enemy-occupied territory comparable to the Sinn Fein movement in Ireland, to the Chinese Guerillas now operating against Japan, to the Spanish Irregulars who played a notable part in Wellington's campaign or – one might as well admit it – to the organizations which the nazis themselves have developed so remarkably in almost every country in the world. This 'democratic international' must use many different methods, including industrial and military sabotage, labour agitation and strikes, continuous propaganda, terrorist acts against traitors and German leaders, boycotts and riots.

It is quite clear to me that an organization on this scale and of this character is not something which can be handled by the ordinary departmental machinery of either the British Civil Service or the British military machine. What is needed is a new organization to co-ordinate, inspire, control and assist the nationals of the oppressed countries who must themselves be the direct participants. We need absolute secrecy, a certain fanatical enthusiasm, willingness to work with people of different nationalities, complete political reliability. Some of these qualities are certainly to be found in some military officers and, if such men are available, they should undoubtedly be used. But the organization should, in my view, be entirely independent of the War Office machine.²⁸

Halifax saw the Prime Minister, and Churchill agreed to go ahead; but there was some delay, due perhaps to an intrigue by Brendan Bracken.²⁹ Restive staff officers outside the inner circle continued to protest: MIR for instance put forward another paper on 4 July, in which it was laid down that 'irregular operations do not mean uncoordinated activity. Everything that is done must

be done in accordance with a clearly conceived strategical plan ... unless action on these lines is taken on a large scale, it is demonstrably impossible to win the war'.³⁰

The delay lasted little over a fortnight: on 16 July 1940 Churchill invited Dalton to take charge of subversion,³¹ and with this invitation SOE was born.

Neville Chamberlain arranged the details, as the last important act of his life; he went into hospital a few days later. On the 19th he signed a most secret paper which had been circulated in draft to the people most concerned nearly a week earlier. In this document, treasured by SOE as its founding charter, Chamberlain explained that on the Prime Minister's authority 'a new organization shall be established forthwith to co-ordinate all action, by way of subversion and sabotage, against the enemy overseas ... This organization will be known as the Special Operations Executive.' The paper also laid down that SOE was to be under Dalton's chairmanship; that Sir Robert Vansittart was to assist him; and that it 'will be provided with such additional staff as [they] may find necessary', a powerful lever for extracting officers from other services. Various arrangements for consultation and liaison between departments were made; all subversive proposals were at least to be approved by the chairman of SOE, even if other departments were to carry them out; in return, he was to secure the agreement of the Foreign Secretary and other interested ministers when relevant. 'It will be important', the paper says mildly, 'that the general plan for irregular offensive operations should be in step with the general strategic conduct of the war'; so Dalton was to keep the chiefs of staff 'informed in general terms of his plans, and, in turn, receiv[e] from them the broad strategic picture'. On the 22nd the document was given the War Cabinet's approval, after a minor amendment. There was some discussion, limited in the minutes to the observation that 'It would be very undesirable that any Questions in regard to the Special Operations Executive should appear on the Order Paper' of the House of Commons. If any did slip through, Dingle Foot the Parliamentary Under-Secretary to the Ministry of Economic Warfare, whose task it was to field them, would say blandly that he had never visited the spot to which the honourable member referred, and had no idea what he or she was talking about.³²

SOE's godfathers, Chamberlain and Dalton, came one from each side in politics; each was specially unpopular with the other side, but in the summer of 1940 this did not count for much. The elder was in any case straightway removed from the scene by illness and death; but the younger had energy and enthusiasm enough for two. Dalton ardently believed in the power and importance of political and subversive warfare, and welcomed the clandestine addition to his public responsibilities, which were hardly up to his weight in his party's team. In a secret paper of 19 August, entitled 'The Fourth Arm', he pointed out the overlaps between section D, which was now under his control, and MIR which remained for the moment under the War Office;

pleaded for co-operation from the navy, army, and air force alike; and maintained that 'Subversion should be clearly recognised by all three Fighting Services as another and independent Service'.³³ Indeed, at that time the British strategic situation was so desperate that the highest hopes were placed in the new executive. Sabotage and subversion were for a moment expected to take their place alongside sea blockade and air bombardment as the main devices for bringing Germany down. More modest counsels began to apply almost at once. Dalton naively confessed, in this same paper, that 'I have no views on strategy as such, and I shall certainly not attempt to formulate any'; his masters formed them for him. By the end of September, 'the stimulation of the subversive tendencies already latent in most countries' was accepted by the War Cabinet as 'likely to prove a valuable contributory factor towards the defeat of Germany', but subversive operations had already been deposed from a primary to 'a strictly supplementary course of action' which 'must conform with regular operations undertaken as a part of our strategic plans'.

For over a year, in any case, much of the energy of the high command of SOE was sapped away from the body's proper object, inflicting harm on the enemy, by bureaucrats' squabbles and intrigues about the future of political warfare. This dismal story can quickly be put on one side; it is of administrative and personal rather than military interest. The prickly personalities of ministers were faithfully reflected among some of their subordinates; and as Bruce Lockhart put it in a minute to Halifax's successor Eden, 'It is the plain truth which will be denied by no honest person inside our various propaganda organizations that most of the energy which should have been directed against the enemy has been dissipated in inter-departmental strife and jealousies'.³⁴ A year-long series of pitched paper battles between the Foreign Office and Ministries of Information and of Economic Warfare resulted in August 1941 in a treaty. Under this, the old EH department, known as S[pecial] O[perations] 1 while it formed the political part of Dalton's executive, hived off as another new secret department, the Political Warfare Executive. SO2, the more actively operational part of Dalton's organization, formed from a fusion of section D and MIR, then took over the title of the whole: SOE.³⁵

The setting up of an independent PWE marked of course the death of the 'fourth arm' concept, the idea of an integrated politico-military striking force that could work alongside the conventional fighting forces as an equal or even as *primus inter pares*, and bring the enemy down by blows directed at him from within his own regime. A commentator on PWE remarks:

The original plan for a single department of subversion and special operations was sound. It is difficult to believe that had its constituents been fused on its formation and regional directors appointed responsible for all forms of political warfare and subversion and special operations within their areas, the work of both of what became PWE and what remained SOE might have been carried out more efficiently on a larger

scale. Certainly there would have been none of the jealousies and disputes in the field, and in the council chamber.³⁶

It would have been interesting to see how a democratic government could run such a scheme; but in the political and administrative circumstances of SOE's birth in London, it was just unworkable. At least the separation of PWE from SOE did enable the more strictly military part of the body to get on more easily with its duties.

II

What SOE was

This brief sketch of the nature, purposes, and organization of SOE must begin with a blinding glimpse of the obvious: special operations have to be wrapped in secrecy. A dense veil of secrecy was indispensable for SOE, a body for mounting surprise attacks in unexpected places: no secrecy, no surprise. The fact that the body existed at all was for long a closely guarded secret. Even within the other armed services, numerous people who dealt with the Inter-Services Research Bureau, or the Joint Technical Board, or Special Training Schools Headquarters, or the Admiralty's NID (Q), or MO I (SP) at the War Office, or AI IO at the Air Ministry – some of SOE's cover descriptions – had no inkling of the real name and nature of their correspondents. Some people in high places in other departments knew a lot about SOE; most of them were more or less co-operative, though a few were determined to wreck it. Less dangerous than these, but equally tiresome, were the officials who knew a little about SOE, neither liked nor trusted what they knew, and so were jealous. For example, as late as the winter of 1943–44 administrators at the War Office sought to hinder travel abroad – even on operations into France – by army officers employed by SOE, on the ground that the security of the impending invasion would be compromised unless the director of staff duties could first be personally satisfied that every journey was necessary.¹ Petty obstructionists of this kind lay about SOE's path all its life, and some have pursued it since its winding-up; they were intrigued by the cloak of secrecy, did not understand its importance, and wanted to pry beneath it. Most were simply self-important busybodies; all were a nuisance.

Below the cloak, the dagger: the next most obvious thing about SOE is the atmosphere of adventure and daring, often with a touch of light opera thrown in to join the tragedy and romance. Churchill's directive to Dalton was brief and simple: 'And now set Europe ablaze.'² Dalton and his staff did what they

could to comply. In a fuller conversation with Hambro, SOE's first head of operations into north-west Europe, Churchill elaborated his directive a little: SOE, he laid down, was to be an unavowable secret organization to carry out two tasks. Firstly, it was to create and foster the spirit of resistance in nazi-occupied countries; this became next year the principal role of PWE. Secondly, once a suitable climate of opinion had been set up, SOE was to establish a nucleus of trained men who would be able to assist 'as a fifth column' in the liberation of the country concerned whenever the British were able to invade it. This second task could probably best be promoted by committing, or at least instigating, acts of sabotage; small ones to start with. Churchill and SOE were both aware from the beginning of the danger that sabotage might trigger off savage reprisals, if too much of it was done too soon: SOE's approach to armed activity in France was consequently tentative and slow. Yet although agents tiptoed into the pool of sabotage from the shallow end, some of them were soon swimming strongly. In the resulting records, tales of derring-do fit for the reading of a schoolboy are entangled with tales of intrigue and treachery of a Proustian complexity; high strategy and low tactics are frequently hand in hand. The truth is that SOE was an essentially unorthodox formation, created to wage war by unorthodox means in unorthodox places. Nothing quite like it had been seen before; probably nothing quite like it will be seen again, for the circumstances of Hitler's war were unique, and called out this among other unique responses.

SOE's work was true to the tradition of English eccentricity; the sort of thing that Captain Hornblower or Mycroft Holmes in fiction, or Admiral Cochrane or Chinese Gordon in fact, would have gone in for had they been faced with a similar challenge; the sort of thing that looks odd at the time, and eminently sensible later. The bravery of many of SOE's concepts is plain; their eccentricity is less obvious now that irregular operations in revolutionary situations have again become familiar (Malaya, Kenya, Algeria, Cyprus, Cuba, Congo, Vietnam, Nicaragua, Bolivia, Aden, Chechnya, Afghanistan). To think up schemes of piratical daring in a war that opened with ceremonial dress and sword drill; to wage in the early forties a kind of warfare that did not become common till the late fifties; such feats argue some imaginative capacity. The key characteristics of SOE operations were suddenness, subterfuge and flexibility; stabbing attacks were planted between the chinks of the enemy's military and economic armour. These were meant to induce in him a feeling of insecurity, and to weaken him strategically; both directly by material loss, and obliquely by dispersing his forces on to police tasks. SOE might have likened itself to the gadfly Hera sent to madden Io, for unsettling the minds of enemy commanders could be of critical importance. If they were unsettled enough, commanders would lose their grip on the main battle, lose the campaign, even lose the war; SOE's task was to promote this desirable unease.

That SOE was set up at all was a victory for the ‘strategy of indirect approach’ that Liddell Hart and others had preached so earnestly in the years between the wars as an alternative to the frontal slogging matches that had drained away the best men of Europe in the great war of 1914. Liddell Hart himself, ironically enough, did not accept this extension of his own doctrine. He held to a more conventional view of resistance forces, as adjuncts unable to exercise more than a secondary influence on a campaign; charged moreover with dangerous political implications for the aftermath.³ The principle of applying leverage to topple a large object is as old as the pyramids. In this respect at least SOE was an orthodox instrument, for all its radical air; it was a lever for toppling the power of dictatorships, and one which operated in accordance with the principles of military mechanics. It would be absurd to describe SOE as the only lever that overturned the axis powers; it was not even the only body engaged in clandestine war. It was one of nine wartime secret services (the others were the Auxiliary Units, that were to have disrupted the invasion Hitler cancelled; the security, intelligence, decipher and escape services; the Radio Security Service; the Political Warfare Executive, that grew out of SOE; and, smallest and most important, the deception service). It provided one lever among many, open and secret; its leverage was powerful, but not all-powerful. Naturally it was in competition with the rest for scarce resources, aircraft in particular. Harris, with his belief – proved true in an unexpected sense at Hiroshima – that bombing operations alone could wind up the war, was not readily persuaded to part with even a few of his precious aeroplanes to carry apparent ragamuffins to distant spots, in pursuit of objects no one seemed anxious to explain. Portal used to say to Sporborg, a principal figure in SOE, ‘your work is a gamble which may give us a valuable dividend or may produce nothing. It is anybody’s guess. My bombing offensive is not a gamble. Its dividend is certain; it is a gilt-edged investment. I cannot divert aircraft from a certainty to a gamble which may be a gold-mine or may be completely worthless.’⁴ Suitable men and women were hardly more easily come by than suitable aircraft; suitable stores were often almost, sometimes quite unobtainable. And throughout the pursuit of scarce weapons, agents, and vehicles – indeed, at every end and turn of its organization and working, at home or abroad, SOE was dogged and hampered by the paramount need for secrecy. Security will be more fully covered below; but as it permeated all the organization’s work, it has had to be brought in from the start.

Politics also will be more fully covered later; all that needs to be said at this stage can be put in a few lines. The body’s task was to help break nazi power, and its politics were simply anti-nazi; they did not favour or disfavour any other political creed at all. Notoriously, SOE supported right-wingers against left-wingers in Greece, and communists against monarchists in Yugoslavia, because that seemed to be the best way to defeat Hitler. On the French political front, SOE only took sides to the extent that it was always

against Pétain, and came, more and more as time went on, to support de Gaulle; people planning and taking part in its operations in France ranged from outside-right cagouleurs to outside-left communists, through all the centre ranges of opinion. SOE was ready to work with any man, woman or institution, Roman Catholic or masonic, trotskyist or liberal, syndicalist or capitalist, rationalist or chauvinist, radical or conservative, stalinist or anarchist, gentile or Jew, that would help it beat the nazis down.

One other general comment needs to be made early. Though this book deals almost exclusively with France, the range of SOE was much wider, indeed world-wide. Though several large sections of it worked mainly into France and what they did was important, they were not unique; and the attention of such high command as SOE had was seldom wholly available for French problems, because there were many other responsibilities to distract it. Naturally it would be interesting to know how extensive these responsibilities were. But there was no strong central personnel branch till well on in 1943, recruiting was never centralised, and many of the financial papers have vanished, so it would not be easy to establish an exact figure even for SOE's total strength, were it possible – as it is not – to define who did and who did not belong to SOE. The available figures suggest a peak, in mid-summer 1944, about equal to that of a weak division; just under 10,000 men and some 3,200 women. But the brute statistic does not signify much. No single division in any army exercised a tenth of SOE's influence on the course of the war, not even Student's airborne force in Crete or Gale's in Normandy. Moreover, one in eight of SOE's women and about one in four of the men were of officer status, either as agents in the field – who were nearly all commissioned – or as staff at bases, or at work in neutral countries under diplomatic, journalistic, or business cover: again, a disproportionate arrangement, suitable to SOE's disproportionate importance in the war. A brilliant historian, W.J.M. Mackenzie, then of Magdalen College, Oxford, who had risen during the war to be secretary of the Air Council and therefore knew something about strategy, was invited to write SOE's in-house history, though he had never been in SOE himself. He wrote the book in the late 1940s; it was graded secret for over half a century, and published at last in December 2000 by St Ermin's Press. It is the starting-point for every serious study of SOE; most of the rest of this chapter relies on it heavily, and the present writer's general debt to it will become clear below.

Fortunately, it is not necessary to examine here in detail the intricate and ever-changing pattern of SOE's higher organization; but some outline is needed, both of what it was and of how it fitted into the rest of the machine for making war. It will also be convenient to introduce some of the symbols by which various officers and branches of the organization were known; they were many, and also varied often. An American president who wanted to create a body of this kind would have made it a federal agency directly under himself as Roosevelt did when he set up the OSS two years later.

While Chamberlain was still leader of the principal party in the government, this was too much; SOE was put under a comparatively junior politician outside the War Cabinet, the Minister of Economic Warfare. SOE might have done better if it had come directly under the Minister of Defence, Churchill himself; but it might also have done worse, through being tied in too closely to the machinery of conventional warfare. And such an arrangement at that early stage might have done Churchill's own still shaky standing as much harm as good.

The minister in charge, known in the office as SO, bore the burden of responsibility for his subordinates' decisions, while unable to take much share in how they were arrived at; playing Hindenburg in fact to the Ludendorff of his operational chief with whom – for the second half of the war, at any rate – he used to have a regular daily meeting to discuss current policy. The normal channels of ministerial accountability to parliament did not apply. Some of SOE's often heavy expenses – particularly for weapons and military stores – were borne by other ministries, which acted as carriers or suppliers; in wartime the rigid Gladstonian rules for inter-departmental accounting were relaxed, and SOE did not have to pay for many services rendered to it, particularly by the RAF. Its other costs were covered out of secret funds over which parliament had no real control, in so far as SOE was unable to cover them itself out of various adventures, more or less colourful, that do not concern this story. In the end, when SOE was wound up, it was in the unique position of having made a profit. The War Cabinet had laid down at the start that its activities were not to be disclosed at question time; as its existence was an official secret, its affairs could not be debated. In practice SO answered to the defence committee of the War Cabinet; and the Prime Minister, though continuously busy, could usually find time to provide guidance and advice, and once or twice sustained SOE loyally when it was hard beset by enemies at home.

Dalton, ill fitted by character for the role of Hindenburg, was more a King Stork than a King Log; but four years' battle area service in the war of 1914 and twenty years of economics and politics had hardly equipped him technically to interfere in detail in sabotage or similar operations. Aided by a trio of much younger and less experienced personal assistants – Hugh Gaitskell, Christopher Mayhew, and Robin Brook – he made frequent incursions into the routine work of the office, but seldom with effects noticeable in the field. Naturally combatant, he was primarily a politician. He felt that his role as one of the initiators of SOE entitled, indeed obliged him to fight for it in the political jungles that he moved in, and he did much hard work that guarded it against a number of attempts to nibble away its independent status. But his manner in controversy could not be described as endearing; and though he made SOE respected, he did not make it liked. On the contrary, his doctrinaire tone made enemies – it was no secret that he got on badly both with Eden as Foreign Secretary and with the successive

Ministers of Information, Duff Cooper and Bracken – and did not commend him to the service departments, always nervously suspicious of theory. In February 1942, at a dark period in SOE's fortunes, Dalton was moved on and up, to be President of the Board of Trade. His successor Lord Selborne, an independent conservative and a personal friend of Churchill's, was no less resolute a minister, indeed a man of great political courage, but a much more conventional one in his dealings with his staff. He was also a more successful conciliator, and he had what Dalton conspicuously lacked: the knack of making people like and trust him. His appointment made SOE's relations with many other departments at home a good deal smoother. It is just worth noting that the change of minister effected no change at all in SOE's general policy abroad, which lay outside British party disputes.⁵

The dominant figure in the organisation; so far as there was one, was the executive director, known by the symbol CD. There were seldom if ever more operations of first-class importance going on at once than one active man could run; CD's task was to impress his personality on all his subordinates, providing them with leadership and strategic control through the veil of anonymity that was held indispensable for the head of a secret service. He also had to do his best to keep SOE's end up in Whitehall, and for this purpose the veil was sometimes more a hindrance than a help. Dalton thought better of his original choice of Spears,⁶ and late in August 1940 appointed Sir Frank Nelson. The change of mind was certainly significant for France.⁷ Nelson had spent many years in India on business, had served in the Bombay Light Horse, had been a conservative MP for Stroud from 1924 to 1931, and had served as British consul at Basle for the first winter of the war. He bore the brunt of the work of getting SO2 on to its feet, and laid down the main lines it was to work on; the effort burnt him out, and ill health forced him to resign in May 1942.⁸ His second in command and successor Sir Charles Hambro, half a generation younger, was a former Coldstreamer and a prominent merchant banker.⁹ He had already done SOE good service. In September 1943 a difference of opinion with Selborne on a point of policy – not affecting France – compelled him to resign. By this stage in the war, when SOE's work had become executive rather than preparatory, a soldier was felt to be a better head than a civilian; the last CD was Hambro's deputy, Gubbins, lately promoted from brigadier to major-general. He was a regular gunner, much concerned in MI R's guerrilla projects as we have seen; had won a DSO in Norway, where he commanded the independent companies, an inspiration of Holland's which later evolved into the commandos; had been secured by Dalton for SOE in November 1940 'after much battling with other claimants for his body',¹⁰ and had been eminent on its staff since.

There was never any equivalent in SOE to the permanent under-secretary in an established department; indeed for years there was no settled office system. At the beginning, Dalton brought in Gladwyn Jebb, who had been

his private secretary when he was Parliamentary Under-Secretary at the Foreign Office in 1929, as 'Chief Executive Officer' (CEO). Dalton has recorded that

in my judgment, no man of his generation in the Foreign Service, or of the older generation whom I knew, has a more exceptional combination of high qualities – a handsome presence, brains, initiative, ingenuity, charm (when he cares to use it), humour, courage, energy, physical and mental endurance, and unswerving loyalty to those from time to time set in political authority over him.¹¹

Cover for Jebb's appointment was good: the rumour was put out that Halifax had set him to keep an eye on the wild Dalton.¹² In fact, the duties of Jebb's high-sounding title resolved themselves into control of SO2 and liaison with the Foreign Office and the intelligence service; CEO's authority over SO1 was slight and dwindled. Over SO2 it is most clearly illustrated by the fact that it was he who took the chair, over CD, at the daily early-morning policy meeting held for the body's first year or so in being.¹³ Vansittart, who had also got on well with Dalton ten years earlier, was available in the background as an adviser, but does not seem to have affected day-to-day policy at all, and gradually dropped out of the picture. 'After events had vindicated my premonitions', he wrote resignedly, 'I hoped that I might be occasionally consulted, but that also was not to be.'¹⁴ Jebb returned to diplomacy in May 1942, not long after Dalton left; so far as he had a successor, it was H. N. Sporborg, a city solicitor who became the minister's principal private secretary for SOE's affairs. Sporborg previously had supervised SOE's business in northern and north-western Europe, and when Gubbins took command he became vice-chief below him (V/CD).¹⁵ Cannon Brookes, Sporborg's successor in the private office, was also a solicitor; and the organization was by now well established on a 'country' basis. In November 1943 M. P. Murray, an assistant secretary at the Air Ministry of great tact and ingenuity, was brought in to take another post, D/CD, as deputy for CD on administrative matters: this reform was overdue, and Murray spent two years reducing chaos to order. Among administrative problems, personnel had so far been handled *ad hoc*, or rather *ad hominem*, by each section or sub-section for itself under the distant supervision of Air Commodore Boyle (AD/B), a contemporary of Nelson's, who had worked on air intelligence for over twenty years and became SOE's director of intelligence and security in June 1941. This directorate succeeded to the transient and embarrassed SO3, a body planted at the end of July 1940 by Hugh Gaitskell that wilted instead of taking root. SO3, organized in research 'bureaux' on a regional and country basis, was to have formed the planning and intelligence staff for SO2. The idea was borrowed from MIR, which had launched a group of bureaux of junior staff officers, loosely

co-ordinated by Quintin Hogg, to study particular countries – one of the bureaux was for France;¹⁶ but shortly afterwards MI R closed down. Within two months SO3 was moribund, for lack of forceful personalities to sustain it; its more promising officers were absorbed into the country sections of SO2, and it was finally abolished on 17 January 1941.¹⁷

Country sections were the organizational bricks on which SOE's staff pyramid rested. Each normally worked into a single territory, and was staffed by officers who knew its language well. Their tasks included the finding and briefing and operational control of agents, as well as intelligence and planning work and – inevitably – a certain amount of administration. They were as a rule grouped, by theatres of war, in three or four directorates, each of which might also have some particular subject such as liaison with other departments under its wing. There were separate 'subject' directorates of finance, signals, and supply; and Gubbins, with the symbol successively of M and of D/CD (O), was director of operations and training from November 1940, controlling a few country sections as well. His influence soon percolated all round the SOE pyramid, affecting colleagues, staff subordinates, and agents alike. Through the months of worst disaster, through the fog of battle, through all the complexities of a large, confused, impromptu organization, he pursued steadily the course that he and Holland had dreamed of long ago in Dublin, and had worked out together months before the war. He combined a Scottish highlander's insight with a regular officer's tenacity, a keen brain, and much diplomatic and intelligence experience; and before SOE was two years old an incomparably well placed observer described him as its linchpin.

Immediately under his eye was the operations section, MO under R. H. Barry, a regular light infantryman fresh from the staff college,¹⁸ who handed it over to an airman in May 1942¹⁹ and left SOE for a while. When Gubbins became CD in September 1943 he recalled Barry, who took the titles of chief of staff and of director of plans, and handled most of SOE's relations with the central planning staffs of the regular services, which worked under the Minister of Defence.

By mid-1942 country sections were well experienced in running their own operations, with the help of sea and air liaison sections; the old MO staff were absorbed into other sections, and training was put under the North European directorate, known as the London Group. This had at first been commanded by Sporborg (as AD/S), who handed it over in November 1941 to Gubbins's already swollen directorate. In March 1943 the London Group hived off again under another regular gunner, E. E. Mockler-Ferryman (AD/E), who had also been in Ireland during the Troubles.²⁰

France always held a prominent place in SOE's effort, and often rivalled Yugoslavia for the leading one; geography, strategy, and politics combined to make it necessary for France to be worked by several country sections instead of the usual one. From November 1941 a 'regional controller' known

as D/R was inserted in the pyramid, below M (or, later, AD/E), to command three of the sections working into France as well as N and T sections which dealt with Holland and Belgium respectively. The post of D/R was held in succession by two amateur staff officers, one of whom, Robin Brook, had previously worked at Dalton's elbow. Brook's predecessor, D. R. Keswick (brother of Sir John), had his name removed from the first edition, lest his career in the City should be harmed by news that he had been in SOE. A brief introduction of these three sections follows.

One of them, known as DF section, was just as much a 'facilities' section as the one that supplied clothes or the one that forged documents. The principal difference between them was that the tailors and forgers could live in such comfort as the south-east of wartime England allowed, while most of DF's operators lived in hourly peril of their lives. Their task was to provide clandestine communications to and from western Europe by sea and land; principally, to run escape lines across France into the Iberian and Breton peninsulas. The section head, Leslie Humphreys, a strong administrator who harped on secrecy, kept his people entirely inconspicuous – as unnoticed in London as in the field; this was the main reason for DF's steady run of success. Several hundred passengers were carried; none of them was lost, and the carriers' casualty rate of 2 per cent was far the lowest of the sections we are concerned with, though of course DF's agents did much less to draw enemy attention than did others.

The original F section, the main British body organizing French subversion, was launched by Humphreys in the summer of 1940 when he returned from France; he had been section D's Paris representative, and came out by warship from the Gironde, in circumstances of some turmoil, on 20 June.²¹ In December he moved over to work on clandestine lines, and F passed to a civilian head, H. R. Marriott, long Courtauld's representative in Paris.²² A year later, in circumstances discussed below,²³ Marriott handed over to Major Maurice Buckmaster, formerly a Ford manager in Asnières, who remained in charge till the end; he became a familiar figure to the Gestapo on paper, and to the French and English press after the war.²⁴ In spite of a number of false starts, F section built up almost a hundred independent circuits – networks of subversive agents – on French soil; it armed several scores of thousands of resisters, who fought well. A quarter of the four hundred and fifty odd agents it sent to France did not return. (These four hundred and fifty were, in turn, about a quarter of the total number of SOE's agents who went there.)

This rate of casualty will seem fiercely high to many civilian readers; less so to those who have served in truly combatant units, or who remember those stories in so many regimental histories of battalions led into action by a colonel and six majors that had only an ensign or two left to command them after a single day's pitched battle. The generation that fought in SOE was brought up to remember that an infantry subaltern's expectation of life on the western front in 1917 was three weeks. By the contemporary standards

of the RAF, F section's casualties could even be called light: only ten in every hundred bomber aircrew could expect to survive a single tour of operational duty in the first half of 1942.²⁵ The truth is that wars are dangerous, and people who fight in them are liable to be killed. Would-be agents were told, before they were accepted into F section, that the chances of their safe return if they went over to France were no better than evens: that is, the staff expected to lose half their men and women instead of their actual loss of a quarter. And every one who went, went forewarned.

At first SOE's staff were ingenuous enough to imagine that all anti-German Frenchmen would work happily together; this was at once discovered to be wrong. Strong anti-nazi elements in Vichy France refused to have any dealings with General de Gaulle, who in turn rejected anything and anybody that savoured of co-operation with Pétain's regime. So, on Foreign Office insistence, F section was called the 'independent French' section and was kept out of all contact with the Free French authorities in London, who were at first led to believe it did not exist; of course they soon found out that it did, and were exceedingly angry. A separate country section had to work with the Free French. F section in any case got under weigh slowly, and pressure of operational necessity compelled SOE to make direct contact with the gaullists, who provided the men for the earliest work that was actually done.²⁶ Reports from these men when they returned impressed SOE with the strength of support for de Gaulle in France; and RF section, mooted late in 1940,²⁷ was the result. It began in the spring of 1941 as MO/D, an extra sub-section in M's directorate; and was established in May in a house leased from Bertram Mills's circus at Dorset Square, a short walk from Baker Street or from the Free French offices at the corner of Duke and Wigmore Streets.²⁸ Its first head was one of M's junior staff officers, Eric Piquet-Wicks, a young Inniskilling Fusilier captain who did not turn out to carry the guns needed to deal with his French opposite numbers. J. R. H. Hutchison, a Glasgow ship-owner who had fought at Gallipoli, was put in over him in August 1942; a brave and likeable officer rather than a paragon of efficiency, who found it as hard as Piquet-Wicks or Buckmaster to delegate. All three suffered from over-work. Hutchison left in the autumn of 1943 to train (at the age of fifty) as an agent. For a short while the section was in the charge of Bickham Sweet-Escott, in transit between two other senior staff posts in SOE; Hutchison's proper replacement was L. H. Dismore, once a sub-editor on the Paris *Daily Mail*.²⁹ RF organized several successful coups de main; but its principal task was to stimulate, guide, and service the creation of a unified resistance movement and a secret army inside France. Its role was thus comparable in many ways to the role of a country section working into, say, Greece or Norway, with the complication that the political authority it supported in France was as devoid of constitutional standing as the authority at Vichy it sought to replace. RF circuits' security, and hence their durability, was sometimes poor, and the casualty rate was also high.

Inter-section jealousies within SOE were endemic; between F and RF sections they often raged with virulence. Each of these two sections was sure that its own men and methods were sound, while its rival's were not; each thought the other was unfairly favoured, either by the rest of the SOE machine or by politicians outside it. By a curious chance, an important figure in each section, privately comparing the contribution of the two in retrospect, went so far as to use the analogy of the Belgian butcher who sold horse and lark pie: one horse, one lark. Most of this jealous feeling was froth; though occasionally it had some impact, usually harmful, on operations.

It is necessary to interject at this point some account of the diverse forms taken by the gaullist staff directing resistance, who co-operated closely with RF. Dewavrin (*Passy*) has recounted how, right at the start, on 1 July 1940, at his first meeting with General de Gaulle, he was subjected to a few moments' glacial interrogation and at once appointed head of the second and third bureaux of the Free French staff: that is, to take charge of intelligence and of operations.³⁰ Very shortly he moved on to head the *service renseignements* (SR), the secret intelligence branch, of which the main concern was news of enemy activities. The *service action* under Lagier (*Bienvenue*) looked after clandestine operations, and was soon in incessant contact both with the SR and with RF. In January 1942 the SR and the *service action* were thrown together to form the *Bureau Central de Renseignements et d'Action militaire* under Dewavrin; its offices settled in March at 10 Duke Street, just south of Manchester Square. A little-known fragment of the political geography of wartime London is worth interjecting here. Buckmaster often saw agents at a safe flat in Orchard Court, Portman Square, behind Selfridge's. From that block of flats a mews runs eastwards to a dead end, with a door in it: the back door of 10 Duke Street. Buckmaster and Dewavrin formed the habit of settling any differences that arose by talking them over as they walked up and down the mews.³¹ The 'militaire' was to indicate the new body's separation from another department of de Gaulle's staff, the *service d'action politique en France*, which came under the gaullist department of the interior, of which Diethelm, André Philip, and Emmanuel D'Astier successively were in charge. The French, in fact, like the British, suffered from a multiplicity of secret services working into the same area, and it was not till the late summer of 1942 that Dewavrin was able to dislodge the commissariat of the interior from a brief spell of direct contact with active operations: the BCRAM then dropped its final letter and became the BCRA.³²

Further complications ensued when de Gaulle moved to Algiers in the spring of 1943, as co-president with Giraud of the new French committee of national liberation. SOE could do nothing but observe the struggle for power in north Africa between the giraudist and the gaullist factions; it lasted about a year. In the end Giraud was extruded. Cochet at first headed de Gaulle's secret service in Algiers; but in September 1943 the thirty-one-year-old Soustelle became DGSS, with Dewavrin as his *directeur technique*. A

rear link in London under Manuel, the *Bureau de recherches et d'action à Londres* (BRAL), continued to co-operate with RF in supplying gaullist circuits in France.

This co-operation was among the many anomalies in SOE. RF section staff, mostly British, were fully incorporated in SOE's structure. This meant that they were left a good deal to themselves by their superiors. But they never doubted who their superiors were, or to whom they should look for orders: up the staff hierarchy, through M – or through D/R and M – or through D/R and AD/E – to CD; beyond CD to the British, or later to the joint, chiefs of staff; beyond them to the Prime Minister, the President, and the British and American electorates. On the other hand, the staffs of BCRA and BRAL looked to de Gaulle as their commander-in-chief; secondly to the committee that backed him. If they needed to look beyond, they looked to France, France gagged by nazi power; and to the idea of France of which de Gaulle was the spokesman. Equally, the officers, NCOs, and occasional civilians whom RF arranged to pass into France as agents looked, first and above all, to de Gaulle their leader; but most of them had a secondary loyalty as well, to SOE. They were not enclosed in SOE's structure, as were the RF section staff; yet almost all of them had some SOE training at least, and at any rate on technical points – wireless procedure, say, or sabotage techniques – would normally follow SOE's rules and instructions without question. Gaullist agents' operational orders were usually drafted by the BCRA and then sent to RF for agreement, but might be handled the other way round. In either case both staffs, de Gaulle's and SOE's, had to agree the wording, down to the last detail. Dewavrin nevertheless sometimes gave extra orders to his agents, which he did not feel he needed to reveal to the British.³³ Normally the agreement was settled at a junior staff level; the constant need for it imposed obligations higher up. For both RF section and the BCRA had to keep the other reasonably friendly to itself if it was to make an effective impact on special operations and, through them, on the course of the war.

Joint responsibility for agents' orders carried with it, of course, joint responsibility for their failures and successes. If readers – French readers in particular – feel that in passages below too much credit is being claimed for RF section, they should remember that RF could effect nothing without the BCRA. The converse held true as well: without RF, the BCRA would have had no weapons, and no means of sending its fighting men into the field. Had it tried to send men – as it did sometimes safely send messages – in any quantity through the intelligence channels open to it, SOE would no doubt have found out, and the end result would have been a sharp quarrel between secret services in London, unlikely to be of any long term benefit to the BCRA.

But this excursus has taken us too far from Baker Street. There was a fourth section working into France which came separately under the London Group; both because many of its responsibilities lay outside D/R's territory

and because of the intricate political problems that its existence raised. This section, known as EU/P, did not directly control agents as did the sections under D/R; it was a liaison staff between the Polish government in London and SOE rather than a body that originated policies of its own, and it dealt with Polish minorities outside Poland. One of the largest of these minorities, some half a million strong, was concentrated in the two French industrial areas round Lille and St Etienne. Late in 1940 the Polish minister of the interior, Professor Kot, was prompted by SOE to suggest to General Sikorski that some use should be made of these people to help the allied cause; EU/P was set up in December, by informal treaty between SOE and the Poles, and went to work at once.³⁴ But visionary Polish perfectibilitarians, and incessant Polish office intrigues, prevented the section from doing much work useful from the point of view of general allied strategy. Relations between the Polish ministries of the interior and of national defence were so bad that 'During a long period, ... this SOE section was the sole liaison linking these two Polish departments, an impossible but typical Polish situation.'³⁵ The section head for most of the war – from July 1941 to September 1944 – was Ronald Hazell, an English shipbroker from the Baltic, fluent in German and Polish though he spoke no French at all.³⁶ Twenty-eight EU/P agents went to France before D-Day, of whom seven were lost. One of the section's principal efforts was devoted to preparing a rising in north-east France just before the allied armies arrived; in the end all this effort was wasted, as the armies got there first. In the field the Poles may have done well, but were not inclined to say; they were fond of teasing the French by remarking that they had about 150 years' start in clandestine experience.³⁷ Little information about them survives.

Of these four sections, and of the JEDBURGH teams sent into France after D-day which practically amounted to a fifth, much the most attention will be given below to E, the independent French section. DF, EU/P, and the JEDBURGHs played more limited and less cardinal roles. RF's size was never as great as F's, in terms of trained agents actually deployed, till well after OVERLORD D-day; though its importance was sometimes as great and came to be greater, as France approached the sparking-point of a national uprising in 1944. By then the uprising could only have one leader, Charles de Gaulle; this naturally enhanced the standing of SOE's most gaullist section, and depressed that of a body founded in distrust of the general and in marked distrust of some of his subordinates. In the closing stages the two sections were fused under the combined staff of EMFFI. But the affairs of RF section are comparatively widely known; through the memoirs of de Gaulle himself and of Dewavrin, both of them writing as what lawyers would call witnesses of truth; through the scholarly collection *Esprit de la Résistance* and through its editor Henri Michel's studies on resistance, and through the numerous local publications consecrated in France to local heroes. Besides, the bulk of the archive material on RF agents was never in British hands.

F section's business on the other hand has been for years the sport of sensationalists and ghost-writers of varying quality, and the subject of speculations as over-written as they are under-informed.

There is one point common to the lengthy French surveys of resistance by Dewavrin, *Rémy*; his best intelligence agent, Michel and Hostache the scholars, Tillon the communist, and de Gaulle himself: they tend to refer to F section, if at all, in a glancing and contemptuous tone, as if it were a body of little size and less account, pursuing aims set it by the British secret service that could be neither of interest nor of importance to the French. The Germans viewed it differently. The rest of French resistance they were too inclined to disregard; but F section they feared, and it received their close attention. Readers may indeed feel the emphasis on the independent French section has been overdone below, and has resulted in a lop-sided book. But before an analytical historian can be found who can consider all the evidence dispassionately, correcting exaggerations and overstatements in every direction, it is necessary to have the case for F section fairly and fully stated. Buckmaster's own accounts of it are in no sense official and in few ways reliable, and several of the most widely read books about its agents are in diverse fashions less reliable still.³⁸ The section's real tasks, in helping to evict the Germans from France, and to remove any obstacles to the free development of an independent French republic after the war, need placing in their proper contexts of strategy and politics, and are worth setting out in as much detail as the surviving archives allow and the reader's patience will stand. For the effect of SOE's operations was cumulative; over the months, over the years, groups that began where two or three frightened people gathered together in lonely fields or cafés or on deserted beaches were welded into disciplined and powerful clandestine organizations. Many of these came out in the end, arms in hand, in daylight, to shoot out with the Wehrmacht the question of supremacy. Most of the Wehrmacht's attention was necessarily devoted to the more regular allied forces on the more formal battle fronts; and so much of France liberated itself.

To show how this could come about will involve a lengthy narrative, that fills most of the second part of this book; yet to make the narrative intelligible at all, it is necessary to map out first the staff and the bases from which the fighting agents were nourished. The London headquarters was not a place where fools were suffered gladly, or where the idle could *embasquer* themselves in comfort; many of the staff were uncomfortable companions, dead keen on their work but proud and petulant as a prima donna. Each of the various sections of SOE, necessarily working in partial isolation from the others, thought itself alone indispensable, and complained at first like the component parts of Kipling's 'Ship that found herself' of how it was treated by the other sections to which it was bound.³⁹ Sometimes there was duplication of effort: not only within SOE. On one notorious occasion an SOE-controlled group reconnoitring the dockside at Bordeaux for an attack

that night saw its targets sink under the impact of limpet mines – provided, ironically enough, by SOE⁴⁰ – planted by canoe-borne marines. (This commando operation, FRANKTON, has been the subject of a film and a popular book.⁴¹) Facilities might be duplicated, as well as operations; witness this anonymous lament from one of the technical sub-sections:

The duplication was disgraceful. Station XV put in a letterpress plant to print labels for camouflage purposes. These should, of course, have been printed by lithography. At Station XIV the necessary plant was already installed, but we can only assume that the officers at Headquarters were unaware that such a place as Station XIV existed or what its capabilities were.

It has been driven home to me on many occasions that officers are not aware what does exist in SOE ... every new officer should go on a course and have explained to him what SOE is, what it does and what it has got to do it with.

I can say from my own experience that, if I had had this instruction in the first place, I could have got down to my job of work very much more quickly, instead of being told not to even ask my neighbour what he was doing. I am perfectly ready to admit secrecy is essential, but there are limits to it.⁴²

Some of this crossing of lines was imposed by the need for secrecy, and some by the policies of the chiefs of staff that charged several agencies with operations into the same area. One useful result of FRANKTON was that a clearing office was set up under ACNS (H) in the Admiralty to get notice of all operations, however secret, planned in England; this eliminated most direct clashes. Within SOE, some safeguards were provided at a high level by the council, which was formed in the winter of 1941–42 so that the burden of responsibility resting on some individuals might be more broadly shared. It consisted of CD and a dozen or so of his immediate subordinates – all the directors, and senior advisers on air, naval, and political matters. (The political adviser, Houston-Boswall,⁴³ was unfortunately not appointed by the Foreign Office until August 1943.) Council met every Wednesday morning, as a routine, and more often when necessary, to discuss problems of policy. A comment by an exceptionally well qualified observer on this body in its final form is worth quoting at some length:

Members of Council represented a great variety of experience: out of sixteen there were five regular soldiers (one of them a signaller), two airmen (one ‘wingless’), a sailor, a professional civil servant, a Foreign Office man, a solicitor, an accountant, and [four] business men of various types ... All alike believed passionately in the purpose and possibilities of SOE; the fact that they had heavy administrative duties did not prevent them from speculating and debating on the nature and power of ‘subversion’. There was no agreed and analysed ‘staff college’ doctrine:

but there was none the less an immensely strong 'public opinion' within the organization which expressed itself forcibly on Council level and was felt much lower down. The administration of SOE had many failings which can be defended only by explaining the stress under which the organization grew: but much had been put right by the summer of 1944, and there was a spirit of excitement and personal concern which atoned for much. The distribution of duties was sometimes obscure or overlapping; but the entire staff was looking for duties, not seeking to evade them. This was not an unmixed blessing, but it meant that things somehow got done, fairly speedily and fairly correctly, though not with perfect economy. Luckily the staff as a whole were relatively young even at the top, at least by Whitehall standards, and many of those physically fit for it had intervals of operational experience: if security prevented them from going to the field, at least they took part in training and in many cases visited missions and stations overseas. This had two advantages: the organization was in spirit pretty close to the fighting line, and it suffered less than many departments from sheer physical collapse under the strain of overwork. Few of the 'old SOE hands' were absent from duty through sickness for any long period during the war.⁴⁴

Devoted though SOE's office staff were to their duties, there are traces of the usual disagreements between the staff in London and the fighting men and women in the field. The staff did not find the way they had to 'speed glum heroes up the line to death' altogether comfortable. Security weighed on them, though without the immediacy of its weight abroad; and their work was made harder by their unavoidably limited knowledge of what was possible and impossible on the spot. Reasons of security were held to prevent the senior staff; down to heads of sections, from taking part in active operations: it was taken for granted that, what with persuasion and what with torture, enemy secret police could extract from an identified prisoner anything that he knew, however tough the prisoner was, so no risk was run of exposing them to capture and its consequences. This was why Buckmaster had no opportunity to serve in the field.⁴⁵ The gaullists, a good deal less obsessed by security than the British, did send over Dewavrin, while he was the head of the whole of their secret services; he came back.⁴⁶ Several less eminent British SOE staff were able to visit the field; only two, Yeo-Thomas and Hubble, in fact fell into enemy hands in France, and the enemy got nothing but trouble out of them.⁴⁷ As a rule the London staff had to rely on common sense and imagination, backed by returned agents' reports. These agents could be particularly helpful if the circuits they had worked in survived their departure. For instance, the second in command of the VIC escape line reported that whenever his chief 'was back in the UK he could feel through all messages received how helpful it was to have a person in London who knew the circuit, the work, the personalities and difficulties of the missions in the field'.⁴⁸ But this was not a common arrangement.

There are also, again of course, traces of tensions between SOE headquarters and other organisations prosecuting the war. A few aspects of these disputes call for notice here.

The Foreign Office took little useful interest in SOE in France; much less than SOE's importance as a force that helped to set the bounds for future foreign policy warranted. In the early days the Foreign Office's negative influence was often felt; one or two promising schemes put up by MI R, and several from SO2, were banned by a flat declaration that reasons of state rendered them undesirable. For present purposes only one of these bans was important: SOE's agents were long forbidden to make much stir in the unoccupied zone of France, nor in principle allowed to conduct any operations there without prior Foreign Office approval; even in occupied France they were at first expected to be 'discreet'. Positive influence, in the way of suggestions for SOE activity, there was none; at least so far as France was concerned. Plenty of trouble was caused for the Foreign Office by SOE activities in various parts of the world; and junior diplomats as a rule regarded the organization with disdain, as an ungentlemanly body it was better to keep clear of. Most of them were nurtured in the old-fashioned fallacy that diplomacy and strategy can be conducted on separate lines, and pursued the mirage of a clear distinction between 'subversive' and 'political' activity; SOE knew there was no such thing; constant disputes resulted. After Selborne became SO, the disputes raged less furiously on the lower levels where most of the actual work got done, and there was a fortnightly liaison meeting between CD and Cadogan, the permanent under-secretary for foreign affairs. Sporborg used to see Cadogan almost daily on SOE's behalf, and always found him helpful as well as courteous; not all Cadogan's subordinates went so far in the same direction. His secretary of state while often the pink of courtesy was indifferent to the fate of a body set up against his advice, and lived to recommend its suppression.⁴⁹

Relations between SOE and the chiefs of staff were closer and more cordial; they were somewhat disturbed in the early days by SOE's reiterated claim that CD should sit with the other chiefs of staff automatically and as of right, a claim that was never admitted and that Gubbins, who did not agree with it, eventually dropped. From 1943, CD or his representative was often summoned to attend particularly important chiefs of staff discussions on SOE affairs; CD could also ask that he might be summoned to particular meetings. This arrangement was not quite adequate. SOE's staff may have felt some jealousy of Mountbatten who did sit with the other chiefs of staff as an equal while he was CCO,⁵⁰ and even some ignoble anxiety to get one up on the head of the intelligence service, who for political and security reasons normally did not. A more substantial grievance of SOE's was that almost any subject the other service chiefs discussed was liable to have collateral or incidental bearing on something that SOE did, or to be likely to be illuminated by SOE's experience; so that a permanent SOE representative might

have been useful to the committee as well as SOE. This was never achieved, but CD was able to call regularly at the Ministry of Defence, from the summer of 1943 onwards, and read all the agenda and minutes of the chiefs of staff meetings; Ismay, secretary of the COS committee, went out of his way to be helpful, and this as a rule enabled SOE to declare an interest when necessary. Morton also was always available as a channel for laying points of real gravity before the Prime Minister. At a rather lower level there was close and friendly liaison between Barry and the joint planners, who felt they could call on him for information, advice, or opinion whenever they wanted. They were not quite so forthcoming in return; but there was reasonable co-ordination between SOE's main enterprises and other major operations of war. Selborne's senior staff were prepared to describe him as 'an agent of the Chiefs of Staff' when discussing a major point of policy.⁵¹ Yet it remains a valid criticism of British war planning machinery that subversion never was fully integrated, as the 'fourth arm' Dalton had sketched out, into the general strategy of the war.⁵² This may be regretted in retrospect; it certainly could not be helped at the time. Politicians and uniformed commanders alike were too set in their ways; and the tradition of treating secret services as too secret to be involved in everyday planning activity was too strong. Besides, the security and political dangers were greater than anyone cared to face; and SOE rather prided itself as well on not working in accordance with accepted military ethos and procedure.⁵³

Of SOE's relations with French authorities much will be said below. Less detail is needed about co-operation with the two greater allies. The Russian and, to a lesser extent, the American publics each cherish the myth that their own country alone was the real inspirer and organiser of European resistance; a myth the ascertainable facts do little to support. Figures speak loudly here. Readers will be able to see for themselves below that only some eighty of the subversive agents dispatched to France by SOE – there were well over a thousand of them all told – were American; and nearly all the Americans went in after D-day, because so few of them had any chance of passing themselves off as French.⁵⁴ Some seven hundred British, French and Poles had gone before. Gaullists and giraudists alike were dependent on the British for wireless communications between France and allied territory; and for all their boasts that their communications were overloaded,⁵⁵ the communists were probably in little better case – they certainly gave no impression of being in close touch with Moscow.⁵⁶ SOE had a large say in what the main methods and objects of resistance activity were from time to time to be. Any historian interested in the truth must agree that SOE's influence on resistance in France was sizeable; sometimes indeed it was of cardinal importance. All the thousands of tons of arms and explosives sent in to help resisters came through SOE; without them, resistance could not have exerted a tenth of its actual effort.⁵⁷ And without SOE's RF and AL (air liaison) sections, the unified national control of resistance that was eventually set up under de

Gaulle could never have been got onto its feet at all. To say this is not to deny importance either to the communist or to the American contributions, which were real; it is only to say that neither of them was unique, nor entitled to claim predominance.

No evidence suggests that the Russians made any attempt to influence the French resistance policies of SOE headquarters; though of course communist groups in the field were always happy to secure SOE's weapons when they could, and to use them for purposes London might not approve. The Russians offered their allies no advice or assistance that derived from their own successful exploitation of partisans in the fighting of 1917–20 or in the current war against the Germans; nor even any useful intelligence of German subversive measures used against themselves. In the political context the war was fought in, this was hardly to be wondered at. While the western allies dreaded a revival of the Ribbentrop–Molotov pact of 1939, the Russians expected with equal dread a revival of the anti-bolshevik capitalist combinations of the 1920s; neither party looked forward to the victory of the other, save as a means of securing its own. This mood did not favour useful intelligence exchanges.

Naturally, relations with Stalin's NKVD were formal and distant; they were more amicable with the Americans. Till June 1942 there was no American equivalent to SOE; but the Office of Strategic Services then set up was under 'Wild Bill' Donovan, who had many friends in SOE's high command. (He had been taken round some of SOE's training establishments as early as March 1941,⁵⁸ and Americans began attending them soon after Pearl Harbour.) By an agreement made in September 1942 between the British and American chiefs of staff the London Group of SOE and the relevant section of the special operations branch of OSS were practically fused, in north-western Europe, under the formal title of SOE/SO. (It was bad luck that the initials 'SO' were already in use in SOE's London office;⁵⁹ context prevented misunderstandings.) In practice, this fusion meant that American officers were introduced into many sections of SOE; their intelligence, enthusiasm, and originality made up for their lack of equipment, training or experience.⁶⁰ They kept what remained an essentially British organization lively; but on strictly French subjects – as opposed to French North African ones – their influence on policy was small till the summer of 1944. Dual control and equal responsibility were the principles; but in practice the British kept in the lead. The United States air forces made a decisive contribution in 1944 to SOE's effort in France, but none before it; and, as in the RAF, their special duty squadrons remained outside the command of the special forces they served.⁶¹

One practical instance of Anglo-American co-operation may be interjected here. When TORCH secured Algeria for the allies in November 1942, a base for SOE work was set up at Guyotville just west of Algiers; MASSINGHAM was its internal codename, and its cover name was Inter-Service Signals

Unit (ISSU) 6. Its first commander, J. W. Munn, had previously been in charge of training; he was soon replaced by Douglas Dodds-Parker in January 1943. MASSINGHAM was necessarily a good deal involved in the intricate local politics of Algiers, in circumstances which will need to be glanced at later. It was quite separate from, but worked smoothly with, the OSS mission in Algiers. Within it, there were miniature country sections like the ones in London; only one, AMF, dealt with France. Originally, under de Guéllis, it was a copy of F section, and dealt largely with giraudists; but when Brooks Richards took over from de Guéllis in October 1943, it became an RF-type or purely gaullist organization. This switch marked a stage in de Gaulle's growing ascendancy over Giraud. MASSINGHAM's other chief importance for this story was that the air range into southern France from the Algerian coast was shorter than the range from England, so that some operations could be better mounted and supplied from MASSINGHAM than from the main base. Omitting several barely relevant staff complications, it may be added that in May 1944 MASSINGHAM's British and OSS's local American components were formed into a Special Projects Operation Centre (SPOC), to which the French were admitted also from 20 June; conformably with what was being done in London.

There, SOE/SO was renamed Special Force Headquarters (SFHQ) from May 1944. This was a convenient cover name, to make relations between the directing body and the more regular formations engaged in the coming invasion of France more secure. Numerous security scares had suggested that it was unsafe to involve de Gaulle's London headquarters directly in allied planning; but once OVERLORD the invasion of north-west Europe had been launched, many barriers came down. The separation between F and RF sections vanished, and the fighting troops of both alike accepted orders from the international body into which the staffs of both were absorbed on 1 July. This body, the *Etat-major des Forces Françaises de l'Interieur* (EMFFI), was under the French General Koenig, a personal friend and adherent of de Gaulle. (DF, not directly engaged in resistance operations, remained outside it; so for a time did EU/P.) The setting up of EMFFI will be treated more fully in chapter xii; only an outline note is needed here. Buckmaster and Passy were both placed in supervisory roles directly under Koenig; Passy soon found his way back to the field, on the ALOES mission into Brittany. The bulk of F section's staff manned the 'deuxième bureau' (intelligence) and part of the 'troisième' (operations), which was headed by Barry and also included officers from the air liaison section. F section's intelligence officer remained in Baker Street, in charge of the affairs of those agents who were most firmly anti-gaullist; feeling that particulars of their identities and activities ought not to be handed over at so critical a moment to a partly French staff that included their political opponents and might include their personal enemies. RF's staff looked after the 'sixième bureau' (special missions). The rest of the staff came for the most part from BRAL. 'At length' Thackthwaite

wrote 'it had been recognised that de Gaulle was the only head France would accept, and F, RF and the BCRAL were integrated into one organization. Had this been done two years before, a lasting cause of friction between ourselves and the French would have been avoided. The wisdom of doing this in the middle of a battle needs no comment'.⁶² EMFFI's position was indeed theoretically indefensible: it was subordinated simultaneously to SHAEF and to SFHQ; it could not introduce a single agent or a single store by air without the help of RAF or USAAF squadrons that were subordinate to neither; and anything it planned with marked political implications was liable to be vetoed by any of the three major western allies. That it worked at all was a triumph for *système D*, the capacity for muddling through; and it worked exceptionally badly.

It did include a training section, which eventually came to rest under Dismore's sixième bureau; but it had to operate with such troops as previous training policies had made available. These included another section working into France: the JEDBURGH teams. Each of these consisted of an Englishman, an American, and a Frenchman, of whom two were officers and the third a sergeant wireless operator; all were trained in guerilla tactics and leadership and in demolition work. Their objects were to provide a general staff for the local resistance wherever they landed, to co-ordinate the local efforts in the best interests of allied strategy, and where possible to arrange further supplies of arms. Thirteen teams were dropped into France in June 1944, and eighty more followed; total casualties were only twenty-one dead, low by F section's standards. But JEDBURGHs dropped in uniform, not in plain clothes; just as F and RF agents' work was nearer open warfare than the work of DF's or of more traditional secret service agents, the work of the JEDBURGHs was farther from clandestine warfare still – almost as far as the work of the British Special Air Service, no part of SOE, and the American Operational Groups, which will also need some attention below.⁶³

It may assist the reader to glance at diagrams of the SOE chain of command, so far as it affected France (see Figures 1–3). The references to 'others' are simply to parts of the war machine that did not bear closely on subversive operations in France.

The question of relations between SOE and more, rather than less, clandestine bodies remains delicate. Various secret services were trying to do different things, but sometimes had to do them in the same places; rivalry was the inevitable result. As a rule it was no worse than the rivalry between different ships in the same squadron, or different regiments in the same brigade; but there were exceptions, due perhaps to the intense and savage frame of mind that secret work entails.

With the security service SOE's relations were on the whole amicable, thanks to some judicious early cross-postings which ensured sympathetic treatment of each others' needs; in fact the responsible officer said they 'developed into one of SOE's basic and most harmonious relationships'.⁶⁴

No one will be surprised to hear that SOE's work gave rise to numerous security headaches, some of which will be recounted; but in principle neither SOE nor MI5 found the other an obstacle to its own work.⁶⁵ Again, the regular escape service and SOE were able to co-operate with little difficulty; SOE ran its own routes, some of which are also described below, without any serious crossing of lines – service passengers were quite often transferred from DF routes which they had stumbled on by accident to the more normal service lines, leaving DF's ones free for SOE's own parties and for the eminences of various kinds consigned to SOE as a travel agent. There was reasonable co-operation between the relevant headquarter staffs in London in most cases; though naturally there were some difficulties, both in London and in the field. The conditions of civil turmoil that SOE's agents were intended to promote were often as bad as could be for agents of other secret services, who needed as quiet a life as they could find to get on with their inconspicuous work.

Ronald Lewin reminded us a generation ago that the whole strategic history of the war needed to be rewritten in the light of the hitherto unknown ultra secret – that is, what Allied commanders and a very few of their staffs knew from intercepts about enemy intentions.⁶⁶ Yet few of the detailed studies of ultra that have so far appeared make much mention of SOE; for good reason. SOE's police enemies worked against it with the help of teleprinter, telegraph, telephone and courier connexions between occupied countries and the Nazi high command; none of which the British were able to intercept. Neither the Abwehr nor the SD made much use of Enigma; and even when they did, Bletchley never during the war broke the main Gestapo Enigma key.⁶⁷

SOE could thus function efficiently as a fighting service in France without being brought into the ultra loop. In a conversation with Gubbins in 1974 I discovered the arrangements made. Ismay, Churchill's military assistant, kept a folder on his desk into which he put any ultra signals that he judged would affect SOE; once a week Gubbins or Sporborg or Barry would call on him and read the folder, but take no notes on it; and that was all. It was enough.

The ease of co-operation between departments in wartime London depended partly on where they were. SO worked, naturally, in the main Ministry of Economic Warfare building in Berkeley Square; only a small private office there had any direct connexion with SOE, and the ministry's routine activities provided SO with adequate cover for his secret work. Professor Boltin is in error when he writes that 'The subordination of this organization [SOE] to the Ministry of Economic Warfare clearly showed all-important links with the English monopolies',⁶⁸ for SOE's 'subordination' was nominal only – leaving apart the question whether 'English monopolies' exercised any influence at MEW at all. Selborne found that in practice '80 per cent of my time is devoted to SOE, compared to which the problems of MEW

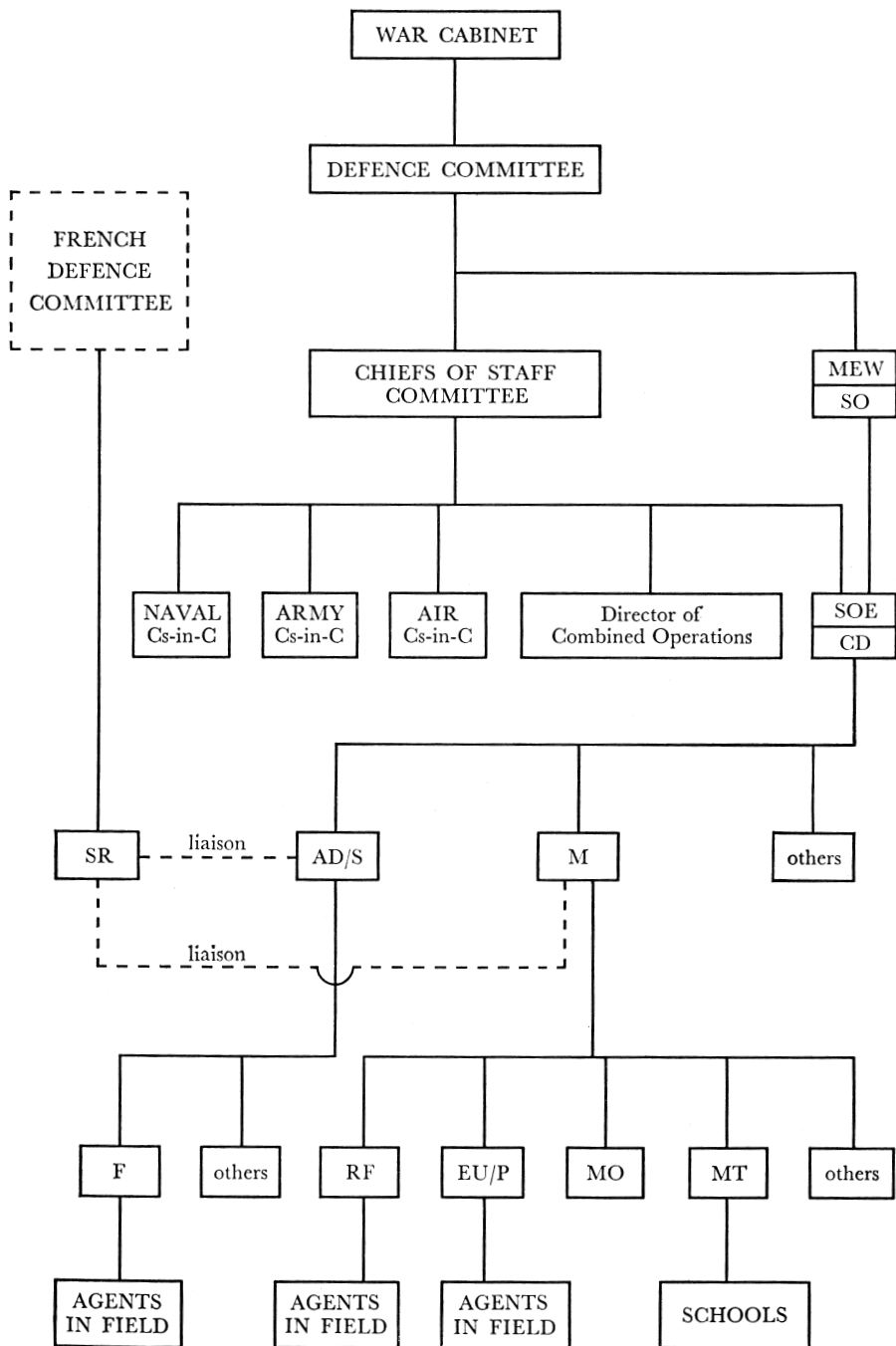

Fig. 1. Outline of SOE chain of command, May 1941¹

From SOE files

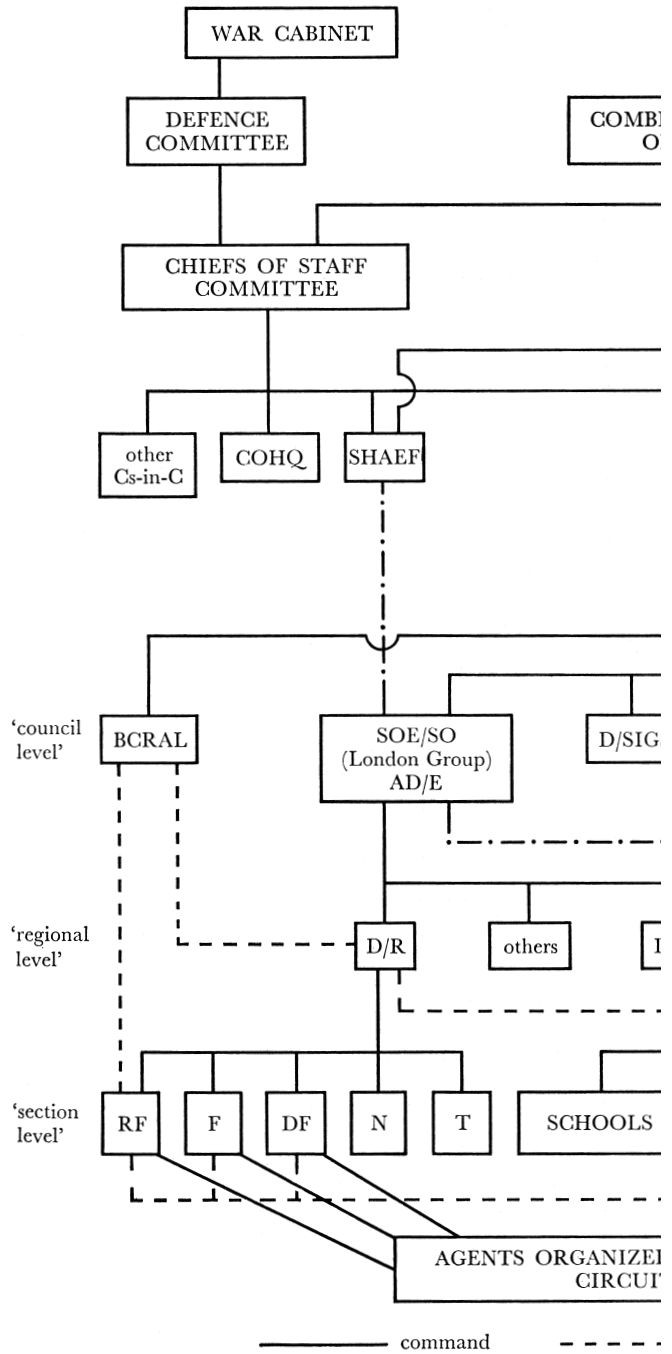

Fig. 2. Outline SOE chain of command, January 1944

FRENCH NATIONAL COMMITTEE

DEPUTY CHIEFS OF STAFF

SOE
CD
CHIEF OF STAFF

AFHQ

D/AIR MASSINGHAM BCRA

D/TRG EU/P

JEDBURGHES AL others AMF others

IN MANY INDEPENDENT STATES IN FRANCE

--- liaison -.-.-.-.- operational control

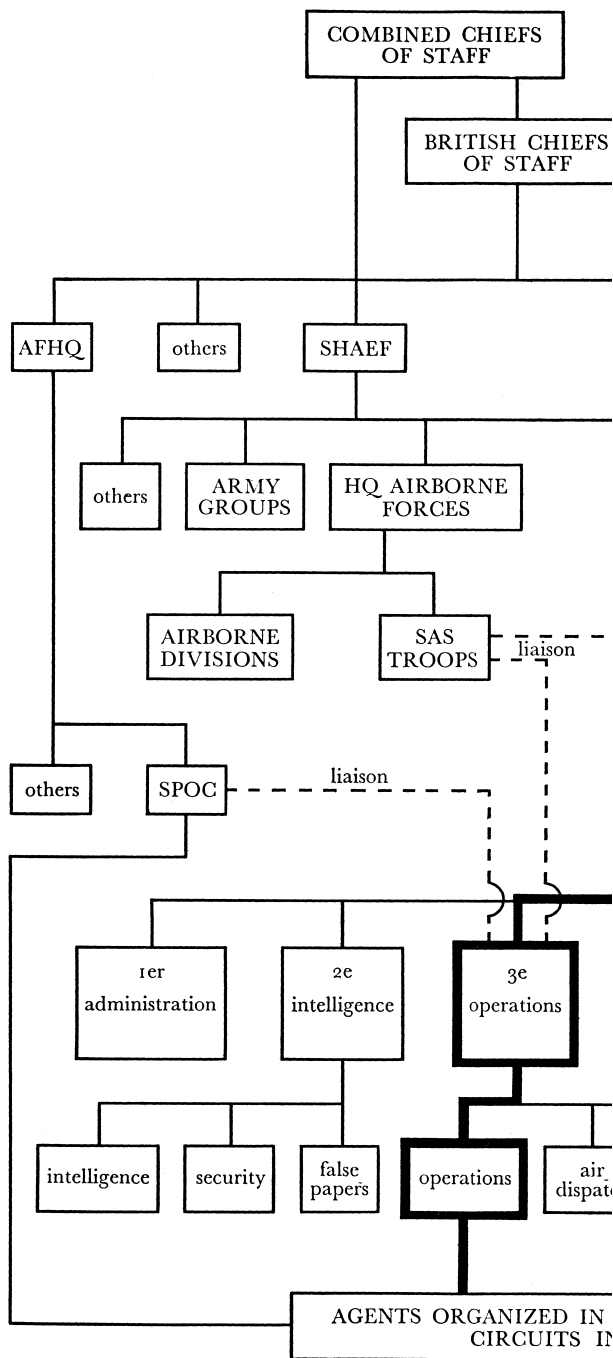
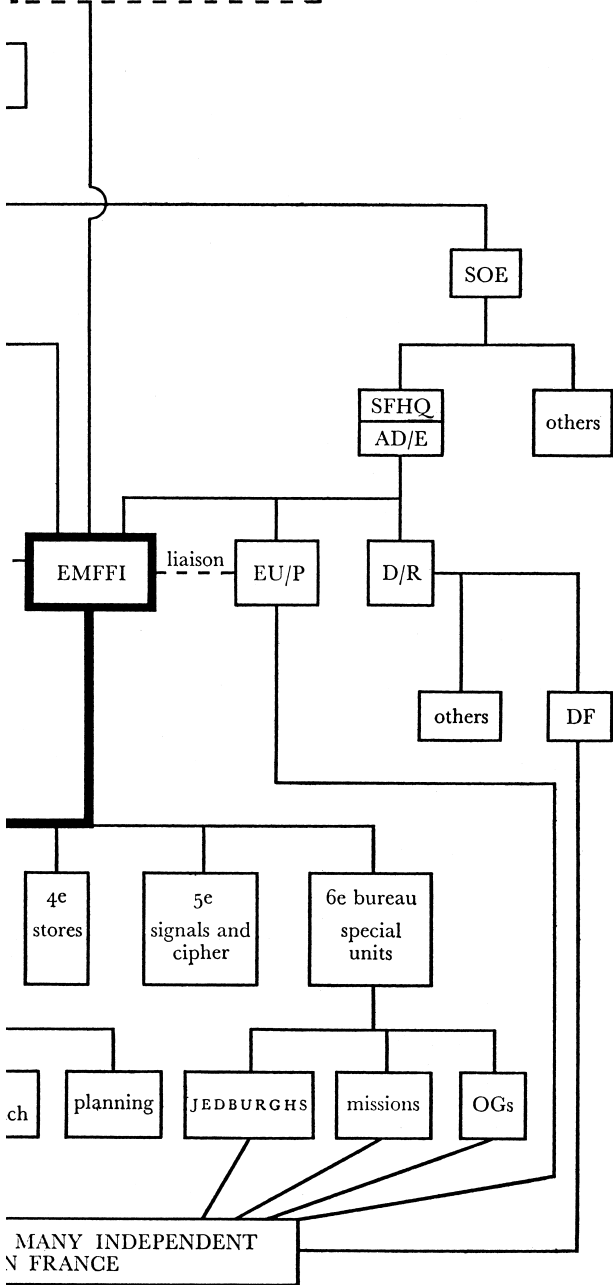

Fig. 3. Outline chain of command, July 1944

FRENCH PROVISIONAL GOVERNMENT



are few and simple'.⁶⁹ SO1 and SO2 were never housed together; most of SO1's work could in any case be comfortably done in the country. SO2's first premises consisted of three gloomy rooms in St Ermin's Hotel, next door to the Caxton Hall in Westminster. After a good deal of searching, a larger and more isolated office was found: 64 Baker Street, just vacated by the prison commissioners. The core of the organization moved in on 31 October 1940.⁷⁰ There was 'great difficulty in persuading the M[inistry] O[f] W[orks] that we had sufficient staff to justify the taking of the whole building'; but 'Within a month 64 Baker Street was full', and five other large neighbouring buildings – Michael House, Norgeby House, and parts of Montagu Mansions and Berkeley Court – were soon occupied as well, though it was not until mid-July 1941 that the Treasury finally gave its sanction to the move.⁷¹ To help maintain the cover, the main telephone switchboard had lines on the ABBey, AMBassador and WELbeck exchanges ostensibly for MO1 (SP), STS, and ISRB respectively; and it may give some indication of SOE's scale to mention that the switchboard began with twelve lines and grew to have two hundred.⁷²

The headquarters offices were thus set up close to each other, but a trifle remote from most other government departments. Constant care was taken to keep their location secret. People from other offices did not normally go there – SOE's officers went out instead. Prospective agents were interviewed in a room provided at the Horse Guards or the dingy Northumberland Hotel, and even if recruited were not supposed to discover where the headquarters was unless their work lay in it. Country sections kept flats in Marylebone or Bayswater or South Kensington, at which agents who were to go on operations could be briefed without finding out where their employers worked. This simple system was effective enough for London taxi-drivers and German security services⁷³ alike to believe that a clandestine organisation working into France was based at the F section flat with the famous black-tiled bathroom in Orchard Court, Portman Square.

III

Recruiting and Training

All the fundamental mistakes that were made in the field in France arose from three causes: wireless direction-finding, faulty original choice of a very few agents who turned out careless or worse, and – especially in RF section – over-centralization. The second cause created much the most trouble; so it would be useful to take a close look at what the recruiting system was. Unfortunately – and this was a radical error – the arrangements for testing and accepting agents were not systematic at all.

A summary of achievements, or the lack of them, at the end of 1940 recorded the difficulties ruefully:

In fact, in the belligerent, occupied and so-called neutral countries of Central and Western Europe no field staff existed. SO2's problem is to get the horse in after the stable door has been shut; and first of all the horse must be found. Recruitment of agents is far from a simple affair. Enemy subjects present problems of security and official procedure: the recruitment of the nationals of the occupied countries tends to bring the organisation into collision with the exiled Governments who are inclined to be alarmed at possible repercussions on their countrymen, or to be just frankly obstructive out of principle.¹

In one way at least SOE was like a club, for membership was by invitation only: 'It's not what you know but whom you know that matters'. Entry was so largely a matter of accident that there was nothing which deserved the name of a recruiting system; though there was system enough to prevent people from inviting themselves to join, and simply walking in. At home, every potential member of the body got careful prior scrutiny; cases of deliberate penetration by the enemy were rare indeed.² George Millar, who did in the end get accepted, gives a vivid picture of the impossibility of talking

himself into SOE, even in the field; Heslop whom he met accidentally in Savoy refused to contemplate employing him locally, though he did reluctantly agree to notify London that Millar might be worth inspection should he manage the journey home across the Pyrenees.³ The men who came forward after the almost routine inquiries that the other service departments put out from time to time, calling for volunteers for tasks of particular danger, most of them went into assault or airborne forces, though SOE was able to take its pick from them. A fair proportion of them sought danger because they were neurotic, or crossed in love; these SOE tried not to take, because a level head and steady nerves were the first of all requirements for its work, but it was not always able to keep clear of them.

The principal recruiting difficulty, security apart, was the need for so wide a variety of characters and skills. Some enterprising officers, both staff and saboteurs, were collected by Gubbins from MIR's pre-war courses, and from among the people who had served under him in Poland, in the independent companies in Norway, and in the 'auxiliary units' he had formed under GHQ Home Forces in the summer of 1940, which were to have acted as the nuclei of a British secret army had the Germans occupied any part of the island. Others came from later batches of volunteers. Yet the swift, intelligent, brutal types who made good saboteurs were seldom patient, careful, or methodical enough to undertake the grinding task of organizing or training an underground resistance circuit, and were not suited at all for the dull and dangerous work of a wireless operator in the field. The technical sections at home needed to be staffed by people of a different type again, experts of real skill: people who could produce, between a Friday and a Monday morning, a virtually indistinguishable copy of a document part printed and part written, first manufacturing and water-marking the paper to do it on and cutting the type to do it with;⁴ people who could design and manufacture portable explosive charges capable of destroying any given piece of industrial equipment; or invent ciphers that were for practical purposes unbreakable, and elucidate messages from frightened agents who had done their ciphering exceedingly badly, without endangering the agents further by calling for their messages to be repeated.⁵ Specialists of such kinds could hardly be found by advertisement; and the same sort of personal inquiry in quarters likely to be well informed that produced the specialists was employed also to collect staff and agents.

In this as in other matters a coherent body of opinion gradually emerged in London: directors and heads of country sections added to their other responsibilities that of looking out for new members, and came to agree on the sorts of people they were looking for; but the tasks involved were so various that no particular 'SOE type' emerged. F section employed a recruiting officer, once described as 'far ahead of anyone [else] as talent spotter';⁶ this was Selwyn Jepson the author, who had a particular flair for this work and exercised it through 1942 and 1943.⁷ The unconventional character of the

force extended from its tactics to its members. Agents' best qualities were frequently not those of conventional serving officers and men; and they normally worked in plain clothes. A few of SOE's most successful agents came from outside the armed forces of any country, and if they were recruited in the field might do valuable work without ever putting on a uniform at all.

All the same, for cover purposes people in SOE were normally given a rank and number in one of the three more regular services if they had none already; usually in the army, and on the General List. Most staff officers held army ranks, most agents were given commissions as lieutenants or captains; a long established and highly successful agent might be promoted as high as lieutenant-colonel, to match – but not to overmatch – the GSO I in charge of his controlling section.⁸ (Three of F section's organizers, Cammaerts, Heslop, and G. R. Starr, reached this rank.) Yet SOE as a body set little store by rank. The mainspring of F section had the captain's grade of GSO III, though long retaining civilian status; and Hambro as the second-in-command of the whole organization had the rank of squadron-leader, though like Nelson he was made an honorary air commodore on becoming CD. For form's sake, to suit the para-byzantine exigencies of War Office administration, when people nominally in the army received or gave up their commissions, were promoted or decorated, became casualties, or were posted to some new theatre of war, the facts had to be recorded in Part II Orders. SOE secured at least that these orders were kept secret for those under its command. The Air Ministry was less convoluted in red tape; the three hundred-odd airmen and airwomen on SOE's books⁹ produced few office difficulties, and the still fewer sailors produced less. The main bone of administrative contention with the Air Ministry was this: how could AI 10, nominally part of the intelligence directorate, account for the expenditure of several million pounds' worth of RAF operational stores?¹⁰

The necessary passion for secrecy involved SOE in administrative complications about notifying casualties. Agents were not allowed, or at any rate not supposed, to tell their families what they were doing. When they went on operations into Europe, their next of kin got a short note once a month or so from MO 1 (SP) or AI 10, according to the agents' service, which usually said 'we continue to receive excellent news' of them. If, as often happened, the agent disappeared the formula was varied slightly, to 'so-and-so was very well when last we heard'; a change so slight that it made no impact on the recipient. Frequently these 'good news letters' went on being sent to close relatives long after SOE knew the agent they referred to was a prisoner; sometimes after the agent was known to be dead. An exceptionally bad case occurred in another country. The distinguished parents of Frank Thompson the poet, a young agent killed in circumstances reflecting a good deal more credit on him than on his captors, received in successive weeks the official notification of his death and a telegram purporting to have just been signed by him thanking his mother for her last letter and sending his love.¹¹ Quite

often such messages were sent at the agent's own request, to spare the feelings of an aged mother or a wife in delicate health; but their wisdom was doubtful. Even after the war, in some cases no proper steps were taken to let close relatives know what had happened: when, or even whether, people most dear to them had died. Philippe de Vomécourt gives a solitary instance of the contrary case: failure to pass on during the war agreed messages truly saying he was still alive. His wife, he claims, thought he had been killed.¹² Yet the actual next of kin of agents known to be dead were always informed at least of the bare circumstance of death, when this could be established; and there are many dignified and pathetic letters of thanks from such people as Diana Rowden's mother for what information time and security and staff shortage made it possible to send them. The trouble was that time pressure and staff shortage were always severe, and the security blanket thick; so many ends were left loose. This is not easy to understand or to excuse; and it has caused justified bitterness, of which Elizabeth Nicholas's *Death Be Not Proud* is an example. Any infantry battalion or air force squadron commander worth his salt made a point of writing to the next of kin of his officers, at least, within hours of their becoming casualties. But in SOE this was much more difficult. RF section, for instance, dared not try to communicate with relatives of dead or missing agents, when the relatives themselves lived in occupied territory; for to do so would have put them into worse peril still. In F section, Buckmaster wrote many letters in his own hand, to relatives on allied soil, when he was quite sure it was safe to do so, but in many other cases he felt he had to keep silent till the war was over, and then demobilisation put him out of touch with detailed inquiries. Moreover, he caused some unintended offence by communicating with some other relatives in a warm, but duplicated, letter signed for him by one of his staff, telling them how to collect dead agents' effects.

One or two points can be urged in favour of silence. Certain news about the arrest or death of agents was usually difficult, frequently impossible to obtain; and it was thought less cruel to let families dally with false surmise than to inflict on them rumours of suffering that might prove untrue. There were obvious security objections in wartime to letting anybody outside the umbrella of the official secrets act know about the fate of a secret agent; it might be fatal to an agent under arrest if a hint of his true identity leaked back to the Germans, and thus destroyed a cover story. (The press was not always reliable on this point; F section thought a short *Evening Standard* article on 11 December 1944 about a DSO for one of its leading agents, Southgate, might well endanger his life by revealing to the Germans, who then held him, how important he had been.¹³) It was also important not to let the Germans know how closely the British were following the activities of the Gestapo. With the end of the war, only the first of these reasons – uncertainty – applied; and devoted efforts were made, by Thackthwaite and Yeo-Thomas for RF and by Vera Atkins for F section, to clear up as many mysteries as

possible. (Buckmaster's tour of France in the autumn of 1944, JUDEX, was devoted to speech-making rather than elucidation of casualty problems; nominally an intelligence and stores inquiry, actually a political demonstration, its administrative value was low.¹⁴) In the end, SOE's administrative winding-up was bungled; and many inquiries that ought to have been pursued were let drop, or never taken up. It is fair to the organization to remember that when it was disbanded in January 1946 by a Cabinet decision, the tiny winding-up staff that was left had other things to do besides following up casualties; and thought it more important to resettle the thousands of survivors from all over the world than to investigate the affairs of the hundreds of dead. Nevertheless, disproportionate suffering has been caused to many people, left long years in ignorance by secret authorities unwilling to admit they had made mistakes or too busy with other affairs to rectify them.

Decorations form another subject that has caused some anguish, though of a lesser kind, and a good deal of gossip, most of it ill-considered or even ill-natured. Secret agents cannot expect public applause; in fiction at least we are brought up to believe that their exploits, however brilliant, remain undecorated.¹⁵ It would serve no useful purpose to rake over the embers of old quarrels in public; let us instead look at a few illustrative cases and figures. The exigencies of the rules for granting honours, which no foreigners and few Englishmen understand, dictated for example that Buckmaster's OBE had to be in the civil division of the order. (He received the legion of honour and the *croix de guerre* from the French, and a high American decoration as well.) These same rules prevented many daring exploits from being noticed at all by awards made under warrants that insisted on gallantry 'under fire' and 'in the face of the enemy'; on top of all the usual difficulties about witnesses, that have kept so many brave men undecorated. Nor is it surprising that many agents killed in enemy hands received no decoration, even for resisting torture; how could satisfactory evidence about what they had done be secured? One of the RAF's few special duty squadrons – 161 Squadron, which originated from the King's Flight – received no fewer than 142 awards for gallantry; these awards of course were arranged under Air Ministry auspices, not by SOE. No one would dispute that 161 Squadron's tasks were dangerous and intricate; but so were the tasks of the agents the special duties crews delivered to the field. But the decorations received by those agents who bore the burden and the heat of the day depended on their fate as well as on their bravery: few of the dead could be given anything. F section's agents received three George Crosses – all for women, and two of these posthumous; twenty-seven DSOs; thirty-two Military Crosses; two George Medals and numerous MBES. DF's much less conspicuous agents were less lavishly provided for; the head of DF's best line was awarded a DSO and a few of his other leading-agents had MCS or MBES; one of his staff had a DSO as well; himself, DF had a civil OBE. As most of RF's agents were foreign citizens, they were a good deal less amply provided for than F's; though

special mention deserves to be made of Hutchison's DSO and of Yeo-Thomas's MC and GC which were earned by exceptional gallantry.

This subject needs to be set in perspective. People who have not faced the perils that clandestine agents live among are not well placed to pronounce on the agents' merits. Like any other body of irregulars, the survivors of SOE's agents face the world with private knowledge, that the world cannot share, of what they went through. They know which of themselves were any good, who should and who should not be wearing which medals; they know, but they cannot be expected to say: as Longfellow said of the sea, 'Only those who brave its dangers comprehend its mystery'. People who have served themselves may remember the SAS saying that only the person who holds an award knows what it is really worth, and only the people who fought in the same battle can guess.¹⁶

Two other administrative points need to be touched on: pay and man-power.

It has often been suggested that SOE's agents were paid on a lavish scale that bore no relation to the increments their abilities would have earned in other services. There is nothing in this: they received the pay of their rank, usually paid quarterly in advance into their bank accounts at home. One F agent has claimed in public that his not over-generous pay was tax-free.¹⁷ As a matter of routine, Buckmaster liked to present his agents just before they left for the field with some expensive object – plain gold cuff-links for the men, gold powder compacts for the women – if this could be done without endangering their cover; this gave each of them a harmless reminder of Orchard Court and a pawnable object that might be useful in emergency, and SOE could afford it.¹⁸ On many occasions agents also took with them to the field, or received there by parachute, very large sums in cash; these were needed for sustaining resistance groups. A few of the worst agents tried to spend a lot of operational money on their private enjoyment: none lasted long. Circumstances in the field were such that only the most conscientious agents could render detailed accounts of how their operational money was laid out; this was generally accepted as part of the extraordinary war that SOE had to fight.

Yet in some respects SOE had to conform to ordinary wartime existence. Even in its proudest moments, its headquarter staff could not forget the national shortage of man-power. A running fight with the war establishment authorities went on all through the war;¹⁹ neither side was ever wholly satisfied with the result, but on the French front at least it was hardly possible to complain that there would have been openings to use many more agents, had they been available, for transport and organisation both presented too many difficulties. In fact the security staff maintained in retrospect that in France at any rate 'It would have been more effective to use fewer and better agents', since under the pressure of operational needs 'the class of agent deteriorated'.²⁰

It has long been known that SOE was interested in woman-power as well as man-power. In accordance with the body's usual principle – go straight for the objective, across any social or military conventions that may get in the way – ample military use was made of women, both on the staff and in the field. The bulk of the base cipher operators were girls in their late teens, who proved quick, keen, accurate and secure. Most of the clerks, drivers and telephonists, and many of the base wireless operators, were also women; and particularly charming, intelligent, and sensitive women, usually speaking the relevant languages, staffed the holding schools and flats where agents were held in the last nervous hours or days or weeks that intervened between the end of their training and their actual departure on operations.²¹ Less usual work was found for them as well. The present writer argued elsewhere, just before starting on the present subject, that 'there are plenty of women with marked talents for organization and operational command, for whom a distinguished future on the staff could be predicted if only the staff could be found broadminded enough to let them join it'.²² SOE was such a broadminded staff. There were women operations officers in AL, F, and RF sections, and F section's intelligence officer, the outstanding GSO III mentioned just now, was a woman; to take only the nearest examples. (A head of the training section is even said to have called her – Vera Atkins – 'really the most powerful personality in SOE'.²³) Moreover women were freely used on operations in the field, when there were tasks they could do; in some cases with much success, as will appear, though in others also with tragic failure. Some of the blackest passages in the black record of the nazis' crimes cover their dealings with SOE's women agents, who could say like Marie Hamilton in the ballad

O little did my mother ken,
The day she cradled me,
The lands I was to travel in
Or the death I was to die!

Rumours at least of what might be in store for them circulated in England; and Jepson made sure the women he saw had a full understanding of the sort of risks they were taking on. It would be interesting to know how many were deterred by what he had to say; but no indication survives of how many potential agents left his grimy office without accepting work for the organization, or without being accepted by it. Not many women who seemed promising enough from SOE's point of view to be worth interview would be likely to quail at the thought of a singularly nasty death, perhaps preceded by outrageous torture, if caught; and fighting enthusiasm can be quite as strong in one sex as in the other. There was plenty of field work women could do; for two obvious instances, they made excellent wireless operators, and far less obtrusive couriers than men, and in a resistance organization

courier work was essential. Women did not normally organize sabotage; but Pearl Witherington, a trained British courier, took over and ran an active maquis of some three thousand men in Berry with gallantry and distinction when the Gestapo arrested her organizer. She was strongly recommended for an MC, for which women were held ineligible; and received instead a civil MBE, which she returned, observing she had done nothing civil.²⁴

Thanks to an almost accidental contact between Gubbins and a Scottish neighbour, most of these women were made members of the Women's Transport Service (First Aid Nursing Yeomanry), or FANY; over half of FANY's strength in fact was devoted to the work of SOE. They were mostly – in an old-fashioned phrase – of good family, and were recruited like the men by invitation. Fourteen of SOE's fifty women agents sent into France – all but eleven by F section – held honorary WAAF commissions, secured with some difficulty. Three went in twice; thirteen did not come back. All of course operated in plain clothes, though one at least dressed up to greet the liberating American army in FANY uniform.²⁵ At the end of the war Sir Archibald Sinclair revealed in parliament that some young women had been parachuted into France to assist resistance operations.²⁶ This precipitated a flurry of excited newspaper comment. History and journalism, like nature, abhor a vacuum; and in the vacuum of official silence no end of speculation about what might have happened to these girls has grown. The current state of the French and English press is such that some of these women have received a great deal of attention, much of it ill-informed and some of it ill-intentioned, while many others have been ignored. They will receive no special treatment below; as they would have wished, they will be dealt with like any other agents in their circuits, according to the work they did. A list of all of them who were sent to France on SOE's business will be found below, with an indication of their fates.²⁷

This part of SOE was not the only one that was more or less homogeneous socially. Not unexpectedly, the senior staff came from the English ruling class; though not on the whole from the highest quarters. Apart from some work in the early days by one of the King's brothers-in-law and by officers in the royal household,²⁸ the services of a Sandringham keeper for fieldcraft training,²⁹ a Scottish guardee baronet who was an F section conducting officer³⁰ and one young peer of ancient lineage who was wounded on the coast of Normandy in 1942,³¹ SOE relied rather on business and professional circles than on the landed aristocracy or gentry. This arose from the initial accident that the heads of section D and MIR were both regular sappers whose contacts outside their own service were mainly in the City. A few instances from that then reliable guide to English class, where people were educated, may help to show the sort of people the senior staff were. Dalton was at Eton and King's College, Cambridge; Selborne, grandson of Gladstone's Lord Chancellor and of the great Lord Salisbury, at Winchester and University College, Oxford. Grand was at Rugby and Cambridge as

well as Woolwich, Nelson was at Bedford Grammar School and Heidelberg, Hambro captained Eton XI in 1915 and went to Sandhurst, and Gubbins was at Cheltenham and Woolwich. Mockler-Ferryman was at Wellington and Woolwich; Barry at Winchester and Sandhurst. Hutchison was at Harrow; Sporborg at Rugby and Emmanuel, Cambridge; Boyle at Bradfield and Sandhurst; Humphreys at Stonyhurst, Dijon, and Magdalene, Cambridge; Brook at Eton and King's; Buckmaster at Eton and elected to an exhibition at Magdalen, Oxford, he never took up; Bodington,³² a Reuters man in Paris, long GSO II in F section, at Cheltenham and (for a year) at Lincoln College, Oxford; Bourne-Paterson, an accountant, another of F's GSO II's, at Fettes and Caius, Cambridge; Thackthwaite, a schoolmaster, their opposite number in RE, at St Paul's and Corpus Christi, Oxford. Of the senior staff officers we are concerned with, only Dismore from Ealing County School, Piquet-Wicks, who described his education as 'private and Barcelona university' and belonged to an impeccable regiment, and Hazell, whose schooling was slight but worldly wisdom immense, came from outside the closed social circle of the prewar public schools.³³ Such a social structure had obvious advantages. It provided widely accepted common doctrines of thought and behaviour for the staff. It carried compensating limitations; there were some sorts of project such a staff might be expected to tackle reluctantly, if at all. Hence numerous complaints by communist commentators on SOE that its real objects were reactionary; complaints seldom if ever borne out by the facts.

The comparative social uniformity of the staff, regulars or lawyers or journalists or business men who had been to 'decent' schools, was not matched by any uniformity among the agents. Their diversity was marked: it ranged from pimps to princesses. Nearly all of them, like nearly all the staff, were amateurs at the business of war when they entered SOE. By the time they left, they had normally received as arduous a professional training as the emergency of war allowed. The ideal agent would have Superman's strength, bravery, intelligence, loyalty, skill, and drive; but Superman is the invention of Nietzsche and the comic-strip artists. SOE employed neither supermen nor simpletons. Many agents were remarkably good; a few were remarkably bad. Some were foolhardy, some were fusspots, some, not unexpectedly, were odd, like the English captain with several daring operations to his credit, who was brave as a lion in action and drunk as a lord in between; or the Gascon major, also fearless, of whom a staff officer wrote plaintively, 'I wish he would not use so much scent'; or the man whose small arms training report read 'Dislikes the noise of the Tommy Gun', and yet steeled himself to nine months in France in 1942 and an unruffled walk across the battlefields of Auvergne in midsummer 1944. He had aristocratic connexions; ARMADA, the most successful team of saboteurs, was led by a road engineer and a garage hand. Some agents came from the intelligentsia, the children of dons or poets; many from business houses engaged before the war in Anglo-French trade; some from artisan families in France, railway

workers especially; a few, in another old-fashioned phrase, from the gutter.³⁴ One circuit in urgent need of a courier picked up an excellent one off a barstool in Montmartre; she was later captured, not by her own fault, and when eventually she came back from Germany her only request from SOE was for a decent pair of evening shoes.³⁵

Character and courage varied as much as social origin. Bravery was quite as desirable in an agent as common sense; and as the agents were after all human beings, some were braver than others. When faced by the severest test, knowledgeable interrogation by the German secret police, a few broke down at once: none so fast as the second-in-command of the flourishing FARMER circuit at Lille, a boaster nicknamed 'the human arsenal' by his colleagues, whose docile arrest in November 1943 was followed that same night by the betrayal of his leader the celebrated Michael Trotobas.³⁶ The understood rule was to hold out, saying nothing, for 48 hours; during that time all the people who had been in contact with the arrested agent were supposed to move house and cover their tracks, and when the two days were past the agent was at liberty to say what he liked if the pressures were no longer bearable. The best died silent; or if they had to talk, said nothing the enemy wanted to hear.

The will to hold on under torture depended on motive as well as plain bravery; and what inspired so many of SOE's agents to dare so much was usually patriotism. Sometimes their patriotism was purely British; Heslop for instance, one of the principal stars, once remarked to Millar that no other country was worth anything at all.³⁷ Sometimes as in the de Vomécourts' case it was purely French; 'We could not admit the idea that France had lost a war against the Germans; we had lost a battle, but not a war. The war was still going on, and we must help to win it.'³⁸ For many of the Anglo-French agents the patriotism too was Anglo-French; they loved both countries, and hated the thought of either under Hitler's Germany; so they fought hard to make both of them free.

Nationality was much more important than class; in the field, it could be almost as important as courage. The general rule about staff appointments was only to employ British subjects by birth; or, after the amalgamation with OSS, only British or United States subjects. This rule was in accordance with an ancient principle of British security planning; even then it was of uncertain validity, and its usefulness must diminish in a time when wars of ideas are replacing wars of national interest. But it would be unreasonable to suggest that SOE could have received any sort of confidence from other British services, particularly the secret ones, if the rule had not been fairly strictly adhered to. The nature of SOE was such that the rule could not be followed exactly. Some of SOE's enemies have taken malicious pleasure in the knowledge that a few of its staff and agents were of enemy nationality. Most of these few had some Jewish blood; this made them thoroughly anti-nazi, and their efficiency was beyond question in every case.

In the field, nationality was critical in a different way. As a reflective SOE historian put it at the end of the war,

there is really only one satisfactory method, namely, to be in contact with the widest possible circle of acquaintance in the country *before* the trouble starts. This takes one straight to the point which cannot be too strongly emphasised or too often reiterated – the absolute necessity for local knowledge based on long experience of the country and the people, which can only be gained by residence over a period of many years, living and working with – and speaking the language of – the people. In this connection it should be noted that life in a predominantly British or cosmopolitan colony – such as the diplomatic – is not, in general, very suitable for acquiring the desired knowledge.³⁹

It was normally indispensable for agents in France to be accepted by everybody round them as Frenchmen and Frenchwomen; particularly when passing through the controls that were a regular feature of nazi-dominated Europe. A saboteur who came, did or failed to do his task, and went away again at once could take a chance; he could hope he would meet only cursory controls that would skim through his papers and let him by if they were plausible. But an agent residing in France for any length of time was almost bound to run sooner or later into strict controls that could not be passed unscathed without an accent and vocabulary precisely fitted to the cover story shown on the agent's false papers. A few lonely wireless operators kept themselves so much to themselves that they evaded control altogether; so did a few organizers and instructors in comparatively remote and rural areas. Otherwise, an impeccable command of French was thought to be almost as indispensable as ammunition for success, and agents went without it at their peril. Several of the agents in the ill-fated PROSPER circuit had voices that were detectably not French; they died as a result. Millar's trace of Scottish accent endangered CHANCELLOR, his much safer organization in the Franche-Comté; Longe and Houseman, with little or no French, were lucky indeed to escape from the Vercors, whither they should never have been sent.⁴⁰ After the war the security section observed that 'The evidence on this is not conclusive ... complete fluency is the ideal, but lack of it can be overcome by a high-class agent'.⁴¹ This was not clearly appreciated during the war; with more knowledge of field conditions, staff officers might have realised how common foreign accents became all over Hitler's Europe.

Remarkably few people born English speakers can manage impeccable French: this put the severest brake on recruiting for work into France. It was the language difficulty that forced SOE to use so high a proportion of agents who had one French parent at least, or who had spent so many years in France that they had acquired the necessary entire command over what they said in French. This in turn accounts for the substantial proportion of agents who came from the Anglo-French business community; they had more cause

than most other Englishmen to speak the vital language like a native-born Frenchman. They were found either through acquaintances in SOE, or through the War Office's catalogue of foreign contacts. Naturally, native-born Frenchmen and Frenchwomen were used as well – when they were accessible. But SOE often had trouble getting hold of them in the United Kingdom. At midsummer 1940, the time of the initial rush of refugees from France, SOE was not yet born; and neither section D nor MIR was in a position to secure foreign agents, for MIR had not yet faced the problems that would attend their use, while D thought in April that to do so would be 'an extremely dangerous proceeding, and one which we have not adopted hitherto nor dare adopt'.⁴² By the time SOE was in working order, de Gaulle's London headquarters was in working order too. Most later refugees worth having had come to England specifically to join de Gaulle, and unless F section could catch them before they joined him they might well be unavailable to SOE. De Gaulle sharply resented SOE's attempts to intercept potential gaullist agents at the Wandsworth interrogation centre all new arrivals from France had to pass through, and kept up a steady stream of complaints.⁴³ There remained a certain number of gallant Frenchmen who were anxious to fight the Germans, and almost equally anxious to keep away from French politicians of all kinds. Several of the best of SOE's agents came from this group, but it was not large.

One more large source of recruits remained: the actual population of France, living directly under nazi oppression, without whose aid nearly all the agents sent in from London would have been helpless. 'Taken by and large', Gubbins wrote in an early survey of the field, 'the best men for our purposes are undoubtedly to be found in their homelands, and one of our first tasks must be to find them.'⁴⁴ Time and time again, agents were overwhelmed with offers of co-operation, active or inactive – more and more frequently as the time of liberation drew near. Even at the start, offers of help were more common than attempts to betray; but the danger of betrayal was always present, and they had to remember it always. They were supposed in strict security theory to refer every offer of help to London for vetting before they took advantage of it; but pressure of work in the field was far too severe for this counsel of perfection to be followed, and they simply had to use their common sense and flair. It was the circuit organizers who bore the final responsibility for recruiting people into SOE on the spot, and their fitness to carry this load was among the many points of character considered while they were under training.

What, in fact, was the SOE training system?

To set it up at all, without funds of recent experience to draw on, was not easy. As Buckmaster said in retrospect – thinking as much of operations as of training – 'it was no use trying to do things by the book. There was no book.'⁴⁵ A choice had to be made at the start: whether to train agents by subject or by nationality. Training by nationality had obvious linguistic

advantages, counterbalanced by the undesirability of allowing many agents working into one area to know each other; but on grounds of economy training had to be carried on by subject, different nationalities (except for the Poles) succeeding each other in batches at subject schools. Even more than the French, the Poles maintained their separate national identity in the common struggle, and the only SOE schools their agents normally used were for parachute training; they did the rest of their training in their own establishments. It was out of the question to train every foreign agent in every subject in his own tongue; students often had to learn by eye, watching what their teachers did, as well as by ear through interpreters. To help them, the potential agents on every course had a conducting officer with them, a subaltern or captain sent by their controlling country section. These inconspicuous men and women were important. The best of them were resting or retired agents, as they could offer advice from their own practical experiences. Conducting officers would accompany a party all through their training, would make a point of sharing in such dangers and discomforts as there were on parachute or explosive or field-work courses, and took as their principal task the sustaining of morale; in F and RF sections at least they provided invaluable weekly progress reports on their charges. They were also useful as judges of character, for their longer spells with individual agents gave them better chances to assess them than were open to instructors at the schools.

Up to June 1943, agents intended for France began by being put through a stiff preliminary course of basic military and physical training; this lasted from two to four weeks, and was conducted under commando cover. That is, inquisitive locals were told that commando training was going on; and potential agents sometimes believed the same themselves. This course was held at various training schools in southern England, such as F section's Wanborough Manor near Guildford or RF's, at Inchmery near Southampton, later handed over to the Poles.⁴⁶ It provided a convenient chance to get rid of unpromising candidates. Later, as service interview and selection techniques developed, the preliminary course was replaced by a Students' Assessment Board. The board, consisting largely of psychologists, made a thorough scientific sounding of each potential agent, lasting several days. The new method conformed with the general development of the allied war effort: the slow assembly of a mass of carefully designed war material bound to crush the Axis forces. By this method SOE certainly secured competent and even formidable agents; but some of the panache, some of the splendid absurdity of the early volunteers was missing.

After passing either the preliminary course or the board, agents went through a stiffer para-military course lasting from three to five weeks, held in Group A of the special training schools, country houses round Arisaig on the western coast of Inverness – an area chosen by Gubbins, who knew it well. That country is among the wildest as well as the most beautiful in the island; well suited to the continuing commando cover, and secure from

inquisitive eyes – both for lack of roads, and because naval bases in the neighbourhood had caused the Admiralty to make it a restricted area, (Its beauty varied with the weather: a Dutch agent there in the autumn found it ‘a wretched, barren countryside, thinly populated; rain fell from a heavy sky that never cleared completely ... a most depressing place’.⁴⁷) Here physical training continued, and was extended to include ‘silent killing’ – the most savage form of unarmed combat;⁴⁸ knife work, rope work, boat work, pistol and sub-machine gun training in British and enemy weapons, field-craft, the necessary minimum of map and paper work, elementary morse, and advanced raiding tactics might all be crammed into the course, which included all-night schemes, practical railway demolitions, and a great deal of hard work across country. The most resilient agents coupled this with hard play as well, poaching salmon or raiding each others’ messes for drink. By this time most people on a course would have got to know their companions thoroughly well, have begun to call them *tu* – an almost universal practice among sub-agents in the field – and have started to get the hang of what they might call on themselves to do when they got out to France. Others were occasionally less sure of themselves; some time might pass before they knew what they were doing. One quiet, self-contained young woman, who had given up escape line work in Marseilles in order to train for something more combative, was asked by a less well informed girl on the second day of their para-military course ‘What *are* we being trained for? I answered an advertisement for a bilingual secretary.’ Both in the end went to France, where one did exceptionally well. There were several other cases of prospective agents who realised late, or even too late, what the object of their training was; they could usually be extracted from the SOE machine in time.

Those who had been more fully aware of what was going on gained enormously both in physical fitness and in self-respect. A journalist found that the silent killing instructor

gave us more and more self-confidence which gradually grew into a sense of physical power and superiority that few men ever acquire. By the time we finished our training, I would have willingly enough tackled any man, whatever his strength, size or ability. He taught us to face the possibility of a fight without the slightest tremor of apprehension, a state of mind which very few professional boxers ever enjoy and which so often means more than half the battle. Strange as this may seem, it is understandable when a man knows for certain that he can hurt, maul, injure, or even kill with the greatest of ease, and that during every split second of a fight he has not one but a dozen different openings, different possibilities, to choose from. One fear has, since then, however, haunted me: that of getting entangled in a sudden row and of seriously injuring, or even killing, another man before even realising what is happening.⁴⁹

Demolition training in Scotland included plenty of practice with explosives. The principal one used was a Woolwich invention, long hard to come by, plastic explosive (PE). This, according to a man well qualified to know, 'consists of cyclonite mixed with a plasticising medium; it is considered to be one of the safest explosives and will not detonate if struck by a rifle bullet or when subject to the ordinary shocks of transit; it requires a detonator well embedded in the mass of the explosive. It is particularly useful to us as in addition to its insensitivity, it is plastic and can be moulded into shape like dough.⁵⁰ Agents got to know and handle it as familiarly as if it was butter; which the best types resembled in colour and consistency. They were quite odourless; but other types had a distinct almondy smell, and could also cause headaches. Like any other safe explosive, it would burn quietly; an agent in the Pyrenees foothills is said to have used it for fuel,⁵¹ and an SAS subaltern ate some, mistaking it for chocolate in the dark.⁵²

One other subject the Inverness schools taught, with a skilled poacher's help, was how to live off the country; this was vital knowledge for agents who might have to subsist in mountain areas on little but stinging-nettles. Parachute training at Ringway airfield, Manchester, followed; each agent made four or five jumps, including one by night, and, from 1943, one with a leg bag. (A parachutist can easily jump with many pounds of equipment in a bag strapped to his leg, and tied to his ankle by a cord; he pays out the cord during the ecstatic moments after the parachute has opened, and can feel when it slackens that he is about to reach the ground – a useful thing to know at night.⁵³)

Agents then moved to the Group B schools in the southern New Forest, a set of large country houses near Beaulieu, also in lovely and lonely country, but less inaccessible. Here all pretence of commando training was dropped as far as they were concerned, though the local cover was maintained. They were taught the elements of clandestine techniques and of security; above all, the importance of looking natural and ordinary while they did unnatural and extraordinary things, following the proverbial advice – 'He that has a secret should not only hide it, but hide that he has it to hide'. Many who came back were loud in their praise of Beaulieu's training in what to do and what not to do, how to spot a follower, when to change an address, how to conceal a personality. A scoffer on one Beaulieu course derided the staff's attempt to interrogate him, dressed in SS uniforms, in the middle of the night; he did not last long in France, and got to know SS uniforms uncomfortably well during a two-year tour of concentration camps in Germany. A younger man on the same course long remembered his mock interrogation, and reckoned it had pulled him through a real one some years later, helping him to escape from a net spread expressly to catch himself.⁵⁴

Other intelligence training was given, on coding and ciphering and on the German armed forces, particularly the counter-espionage services; and there was a propaganda school which some agents attended, though the bulk

of propaganda work was left to PWE. At the end of their Group B course, agents were put through a four-day scheme; the scheme included reconnaissance of a target, contact by pre-arranged password with other agents, and in the hardest cases the securing of dummy explosives and their conveyance to and laying on such targets as the Manchester ship canal. During these schemes agents would be carefully watched, often by people quite unknown to them – the security section maintained a small squad of professional seducers, who did their best to try out the talkativeness and susceptibility of the younger men among the agents⁵⁵ – and might well be taken up by the civil or service police and grilled; so that they had to have a cover story pat. WT operators of course had also to have much technical training in their craft, which could not be hurried. It was probably a mistake not to train all the agents as WT operators as well; a great many of the early troubles in France, and many later ones also, could have been smoothed away if the shortage of trained operators had not been as acute as it was, right through to 1944. There were also short courses on how to run a reception committee. There were some other specialist schools as well; the tall, dour Rheam's three-week course on industrial sabotage was justly famous, for Rheam was the real inventor of modern scientific methods of attack on machinery. He was an outstandingly efficient teacher, with strong imaginative capacity allied to exacting standards. He worked his pupils hard; and taught them precisely where to apply a few pounds, or even a few ounces of explosive to secure maximum effect, instead of slapping a lump of plastic on haphazard and running away. Factories in France from Caen to Toulon, from Lille to Bordeaux, from Belfort to Nantes, were put out of action as a result.⁵⁶ With the help of an ex-burglar it was also possible to take a course in lock-forcing and safe-breaking.

Incessantly during these courses agents had it drilled into them that their task was aggressive, that they must make aggression part of their characters, eat with it, sleep with it, live with it, absorb it into themselves entirely; equally, that they must be wholly self-reliant, always inured to disappointment, patient in waiting for an opening, always ready to pounce on any chance however fleeting of harming the enemy.

The trouble about this training system was that it was too short. Some magnificent fighting men and women were brought by it to a fine pitch of combat readiness; these were the people with a marked natural aptitude for subversion, who made an intensive response to the intensive training they received. The objection often urged against SOE that 'amateurs' were sent into the field to combat the 'professionals' of the German counter-espionage services who were bound to outwit them, is based on a faulty appreciation. An 'amateur' in wartime conditions could frequently do as well as a 'professional'; Giskes who devastated SOE's Dutch circuits was a tobacco merchant between the wars, did not join the German Abwehr till 1938,⁵⁷ and seems to have had little but common sense and luck to guide him in his struggle

against Gubbins, a regular soldier who took up clandestine interests at about the same time. Gubbins in turn, also a clandestine 'amateur', was able to score heavily off the German counter-intelligence services in France, among other countries; they contained hardly any 'professionals' at all. Most of the senior Gestapo officers SOE's agents had to contend with were youngish nazi devotees, with plenty of experience of the criminal world many of them had grown up in; few if any of them were highly trained for their work.⁵⁸ Modern Russian agents spent ten years under training; but they were being prepared in nominal peacetime for a plan on a far longer term than SOE ever envisaged. Given the realities of political and military life of the late 1930s and early 1940s, SOE could not reasonably have been expected to do much better than it did; in fact the point where its training can most seriously be faulted is that agents the training staff could clearly recognise to be unsuitable nevertheless in some cases slipped through into the field. This was hardly the training staff's mistake; yet even they were not infallible. They reported adversely on some of the best as well as some of the worst agents who all the same got through to France: this did not encourage trust in them. If at any stage in the training process an agent's nerve did fail, or it became clear to the staff that it would fail in the field, or any other strong reason against his dispatch appeared, a nice problem in security was posed; for the agent was bound to know by sight at least the people on the course with him (their names, with this eventuality in mind, might well be false ones), and if he had reached Group B he might know dangerously much about clandestine techniques. ISRB maintained some workshops in the remotest Scottish highlands, at Inverlair; and to this 'cooler' refractory or unsuitable agents were sent, till the other agents they had known were out of harm's way and it was safe to return them to the general man-power pool.

Much public interest has lately been devoted to SOE's weaponry; much of which was normal army issue. But it did also include oddities: such as the welrod, a one-shot silent pistol, readily concealed in a man's sleeve, or a small dagger that either sex could hide in the lapel of a jacket, and whip out when apparently reaching for a wallet. There is an excellent illustrated guide, by a French scholar-soldier who trained an architect, to all the weapons that SOE sent to France, from which readers can inform themselves; as they can from SOE's own stores list, which is now in the record office and has been edited by Mark Seaman.⁵⁹ Seaman arranged them for visitors to inspect in the secret warfare gallery of the Imperial War Museum, provided by the generosity of Sir Paul Getty, Jr.

Lastly, at the end of the training courses agents went to operational holding schools, one or more for each country section; these had to be reasonably close to the airfields in east Anglia from which most parties left. They might remain at these schools for a few hours or a few months. This set an almost impossible task for the commandants; who nevertheless managed as a rule, with the conducting officers' help, to keep the agents from brooding

and to keep the keen edge of their training from going blunt. (A perhaps unintended aid to continued alertness was provided, at the country house used by F agents, by the plumbing. There was only one bathroom; either sex might use it; it had two doors, and no lock or bolt on either.) If the country section felt sure that an agent would, weather permitting, leave shortly after he had finished training, he could be taken at once to a flat in London, and be given a chance to enjoy himself till it came to briefing time;⁶⁰ but it often happened that the changes and chances of life in the field, so far as London knew of them, would upset the best-laid plans; nor could the Channel weather ever be predicted.⁶¹ The north African arrangements for holding agents who were due to go to the field soon were much less agreeable, and many agents left for France after weeks of discomfort and, they felt, neglect in camps on the outskirts of Algiers.⁶²

IV

Communications

A lengthy most secret survey of 'Considerations affecting SO2's operations', signed by Gubbins in midsummer 1941, concluded that

SO2 operations are dependent to a very large extent on the creation of subversive organizations in enemy-occupied territories ...

The establishment of communications is the pre-requisite for forming these organizations or employing existing ones. Operations are best undertaken from within the territory concerned, but may in special circumstances be staged from this country. Targets must be specific and limited; only in this way will definite results be achieved.

We have in all the occupied territories a host of sympathisers who only await organization, guidance and materials, in order to undertake active operations. Our activities for the time being must be concentrated, with the help of our Allies, on organization and communications; that task completed, we can direct all our energies towards operations.¹

His view of communications was borne out from the other side. One of the most iniquitous of the Gestapo's Paris staff commented later on the account of the liaison system of an intelligence circuit (CND), given him by an agent under pressure: 'That interested me enormously, for my object was always to break up the liaisons, even more than arresting the chaps; what could they do without communications? I left plenty of [his] colleagues free; they were of no interest to me.'²

From mid-1940 to mid-1944, the English liked to think they lived in splendid isolation from continental Europe, connected with it only by occasional commandos and by air raids in both directions. This was far from the case in fact, and farthest where France was concerned. It was not exactly easy to get from England into France; getting back from France to England was difficult; but both journeys could certainly be made. France was not

as shut off as Germany itself; after all, Pétain's two-fifths of it remained unoccupied till November 1942. Till then, the Americans kept a diplomatic mission at Vichy, and the Vichy government kept a representative at Pretoria. The Canadians also, viewing their large French minority, kept in official contact with Vichy, and Dupuy their chargé there was also accredited to the Belgian and Netherlands governments-in-exile in London, so that he had occasion to travel between the two cities.³

South-eastern France had been full of nazi agents even before November 1942, when the last allied diplomats left. The German occupation of all France exposed overt travellers into the old unoccupied zone to overt nazi scrutiny; covert means of entry were little affected by the change, except for one or two courier lines for parcels that had run to and from Vichy. The weather was a far more severe brake on clandestine working into France than were German activities of any kind, outside the heavily defended areas. Weather's effect varied of course with the element involved: cloud or rain might make air operations impossible and sea ones difficult on a night when it made a land frontier crossing easy. Above all, there was the moon. The whole of SOE's early life was geared to its phases. Clandestine aircraft could not land without it; clandestine boating parties could not land with it. Techniques grew more sophisticated with time; but it was always desirable, and in the early days it was essential, for parachute operations to take place while a moon, more than half full, was well up in the sky. As a senior officer put it much later, in SOE 'for at least two years the moon was as much of a goddess as she ever was in a near eastern religion'.⁴ Each element needs separate treatment; and something must also be said about signals and about communications in the field.

(A) SEA

There is now an admirable, highly detailed, micro-history of SOE's and SIS's efforts to send agents into both northern and southern France by sea; prepared by Sir Brooks Richards who had himself, as a young naval officer, been a leading participant at the time and had access to all the papers on this subject that I was forbidden forty years ago to see.⁵ A brief summary of the problems may suffice here. Much of the long French coastline is suited to secret landings. The Breton peninsula, though swept by strong tides, has plenty of small deserted beaches; parts of the almost tideless Mediterranean shore are lonelier still. Naturally the Germans guarded well anywhere of the least military importance; and they formed along the whole northern and western coasts of France a forbidden zone some 25 kilometres deep which visitors were not supposed to enter. The London staff took this seriously; as late as the spring of 1944 the organization of 'counter-scorch' parties to preserve French port facilities was being discouraged because 'It is extremely

difficult to insinuate agents into Maritime Areas as the Germans keep a very strict and careful watch on all the inhabitants.⁶ Agents were less disturbed – they seldom had much trouble in penetrating the comparable closed areas in England, a training task they were frequently set; the *zone interdite* with its special passes and regulations just provided one more set of hazards to overcome. Within it, there were scores of beaches isolated enough to be usable by the most timid; the daring did not insist on loneliness. ‘Generally speaking’, said DF’s sea landings organizer, ‘the best landing points are near a German pill-box, as the garrison of these, knowing as they do that their opponents have photographed the coast, do not expect anyone to be such a fool as to attempt to land under their very noses. My best beach was within 40 feet of an occupied German pill-box, this beach was used on six occasions.’⁷ Only two things were indispensable – calm seas and suitable craft. Some organization at the landward end was useful, but resourceful men could do without it. Hopes were placed on sea operations at the start, for lack of any visible alternative. Right back in August 1940 a paper put up to CEO envisaged one of SO2’s principal tasks as recruiting ‘a carefully selected body of saboteurs ... operating exclusively against objectives on or near the coasts ... and at short notice, at widely separated points’.⁸ On 18 March 1941 Gubbins minuted that ‘all the various parties of men whom we are now training ... may well have to be landed by sea as no other means exist’.⁹ Most of these hopes were unfulfilled; but it is worth glancing at what could have been done, as well as what was done.

The naval requirements for a landing point were not severe. Darkness and fairly calm water, like freedom from offshore reefs or shoals, were essential; and obviously a beach close under the guns of a coast defence battery, or just behind a naval minefield, would not do. The sailors’ only other stipulation was some nearby object, visible from low down off shore, which they could use to steer by: a headland, a church tower, or even an isolated building would do, but ‘some outstanding landmark’ was needed for accurate pin-pointing. The more steep-to the beach, the simpler and safer it would be to use at any state of tide; the more sheltered it was from the prevailing winds, the more often it would be free of surf.¹⁰

Suitable craft were harder to find than suitable beaches. Submarines were ideally discreet for the carriage of passengers, and had some capacity for stores, but were seldom available. The Admiralty was intelligibly reluctant either to risk them close inshore, or to divert them from their more normal tasks; so indeed was SOE. For there was always a fearful risk that accident, indiscretion, or treachery might betray a prearranged rendezvous to the enemy; in that case a powerful warship and its crew might be lost in an attempt to bring out a single and not necessarily a valuable agent. The use of submarines was envisaged from an early stage;¹¹ but as a rule they were only available for purposes thought to be of first-class importance, such as the extraction of General Giraud from the Riviera in the autumn of 1942.

It so happens that one of the half-dozen F section agents put into France during the most active submarining spell, which fell in the spring of that year, was Peter Churchill, whose activities have attracted some general notice; but little that he did was run-of-the-mill work.¹² For obvious naval reasons, the ordinary ways that people took in and out of France by sea were on the surface and not under it.

The risk of naval loss was much less, and in those early days of radar the conspicuousness of the operation was not much more, if a fast small surface craft could be used; and the risk was lower still if a fishing boat could be employed, local in appearance and apparently peaceful in function. De Gaulle's staff made their first attempt to put an agent into France – by borrowed fast craft – as early as 17 July 1940, while SOE was still in its birth pangs, and succeeded in landing him by fishing boat a few days later.¹³

The nascent service did not hesitate to launch its own private navy; this was not a success, though not for lack of effort by SOE. A sizeable staff, headed successively by a commander, a rear-admiral, a captain RN, and another rear-admiral, wrestled constantly with the problem of sea communications, particularly into France; but seldom with useful effect. In the end most of the barriers to seaborne activities by SOE were worn away; but by then the rest of the staff and the parties in the field alike had got used to the still more intricate and expensive processes of operating by air, and the war in western Europe was drawing to a close. When for instance DF was offered, early in 1944, a chance to expand his previous activities by sea, he had to reply it was by now too late to get competent parties trained in time.¹⁴

The principal barriers were three, closely interrelated: shortage of craft, jealous competition, and Admiralty policy.

Not even SOE's finances would run to buying, crewing, and maintaining a destroyer, or any other really fast craft with room inside it for an appreciable quantity of stores. Nothing at all could be got out of the Admiralty in the early stages; though a 41 ft. 6 in. (12.65m) seaplane tender numbered 360 was secured from the RAF. One who knew her well wrote:

This vessel was really both too small and too slow for the work required of her. While handy for quick manoeuvring in rock strewn waters, her small size was a handicap in that it allowed no room on deck for a rigid boat, and the control cabin forward lacked space for reasonable navigational facilities. Her top speed in smooth water was a bare 20 knots and, when laden down with additional fuel and stores for an operation, her cruising speed under the most favourable weather conditions was no better than 15 knots. This meant, of course, that she could not operate during the short summer nights. Bearing these drawbacks in mind, it speaks volumes for the keenness, enthusiasm, and skill of Holdsworth and his Officers and Men that they carried out four successful operations in this boat during midwinter 1941/2 ... In view of subsequent difficulties

over weather with much larger craft, it is worthy of record that two of these operations were carried out in one week at the end of December.¹⁵

360 could carry some stores; but only a ton of them. Roomier fishing craft were sought at once; the original 'intention was to use French fishing craft, manned by picked crews including Breton pilots and fishermen, to contact the Breton fishing fleets working on the Banks off the north-west coast of Brittany with a view to obtaining information and eventually landing stores and arms to the resistance groups' that SOE felt sure from the start were going to be formed.¹⁶ Holdsworth, already in the west country, was told in October 1940 'to get on and fix [SO2] up a transport outfit to operate to Brittany', because other people 'kept on letting them down'.¹⁷ He was able to secure a tunnyman, a long-liner, and a motor-trawler, all French, and each capable of holding five tons of stores or more – the trawler could hold ten; but they cruised at only 7 knots and their utmost speed was 8. Five more motor fishing vessels, two of them rather smaller and a knot slower, were eventually obtained.¹⁸ They were all based in the Helford River, just west of Falmouth on the south Cornish coast.¹⁹ By mid-winter 1943/44 SOE had also got some faster craft out of the Admiralty, three 28-knot MTBs, and two 117-ft (35.66m). MGBs originally intended for the Turkish navy; an air-sea rescue high speed launch was also tried, but not found suitable. These MGBs were small but serious vessels of war; their armament amounted to one six- and one two-pounder, a twin 20 mm. anti-aircraft cannon, two twin .5-in. and two .303-in. machine guns; they had three silenced 1,000 h.p. Diesel engines, could cruise at 21 knots for nearly a thousand miles, could go 6 knots faster for ten-minute spells, and carried a mass of radar and other navigational equipment.²⁰ They needed it: for even these craft were barely a match for the German 35-knot E-boats that frequently patrolled the Channel coast of France. They also each carried a newly designed 14-ft (4.27m) surf boat, 'almost invisible at a very short distance' in special paint,²¹ which agents learned to get in and out of promptly and silently during their courses on the coast of Inverness.²² These five comparatively fast craft could barely carry ten tons of stores between them.²³ A graver disadvantage was that they were not wholly under SOE's operational control. This brings us to the second barrier: jealous rivalry with the intelligence service.

The truth was that the intelligence service needed to make use of Breton beaches, both for its own purposes and for the escape service, to which it acted as carrier; these two services alike were absolutely unprepared to discuss, except with each other or the clearing office, where or when they would operate; and were alike determined to keep Brittany as quiet as possible, in the interests of their own operations. SOE's work would be, they thought, bound to run counter to this; so, in pursuit of their own interests, they did their best to check it. The Admiralty had a high opinion of the intelligence service, for good reason; and imposed for a time a complete ban on activities

by SOE or the CCO between the Channel Islands and St Nazaire. This ban undoubtedly exercised an effect on both British and German strategy; for it made unavailable the part of the continent most suited to small combined operations, and thus hampered raiding development, while on the other hand it gave the Germans a false sense of security. Whether its imposition was worth while, or justified by the results achieved by the services that secured it, are interesting questions which cannot be answered here.

The Admiralty was the third obstacle athwart SOE's naval course. With all the weight of a fully established department of state, long the Prime Minister's favourite, and of a great tradition reaching back through Nelson and Drake to Edward III and even Alfred, their lordships maintained that no operations could take place by sea without their authoritative assent. The Admiralty eventually decreed in the spring of 1943 that all clandestine cross-channel operations would come under a newly appointed co-ordinator, to be entitled Deputy Director, Operations Division (Irregular); adding that 'In home waters clandestine operations are controlled by the Admiralty.'²⁴ This, with the MTBs and MGBs which arrived that summer, seemed to offer SOE a new chance. But the DDOD (I), Captain F H Slocum, RN,²⁵ was regarded – perhaps wrongly – by SOE as an enemy. Hardly anything, except for the MANGO and VAR operations to be discussed shortly, evaded his virtual ban on SOE operations on the Breton coast, except for one occasion when a large party of another service's got accidentally left behind in France – twenty-eight people had to be rescued in a hurry by two SOE crews in the small hours of Boxing Day 1943.²⁶

It was precisely because SOE was anxious to stir up trouble for the enemy that DDOD (I) had a sound point to make. As far back as 16 December 1940, at a meeting held to co-ordinate the activities of SO2, the director of combined operations, and the intelligence service, the last-named body's representative 'expressed the attitude ... that [they] were against Raiding Parties as they might interfere with their organization for getting agents into enemy-occupied territory'.²⁷ Active SOE coastal operations, in fact, might imperil other work of different and perhaps greater strategic importance; and in any case, Combined Operations Headquarters had been set up specifically to undertake coastal raids, so that there was no need for SOE to duplicate its work. But moving agents in and out of France by sea was an entirely different project from landing a party of agents, or indeed of ordinary troops, to conduct operations hard by on the shore; and it would seem as if the sound excuse for preventing raiding – that raids would stir up the Germans – was extended, beyond what it would reasonably cover, to prevent the infiltration of agents from a rival firm. Warington-Smyth, Holdsworth's one-legged successor in command of the Helford base, may be quoted again here; on the effect of the move of DDOD (I)'s fishing flotilla from Falmouth to amalgamate with SOE's fishing flotilla at Helford, in June 1943.²⁸

It enabled everyone to get to know each other, and it came as a source of great surprise to more than one Officer (and to some of the more intelligent Ratings) to discover that – contrary to what they had been educated to believe – the principal enemy was Hitler and not their opposite number in the sister organization. Nothing but good came of this amalgamation at the same Base, and the personnel of the two Organizations at Helford worked thereafter in the closest co-operation, with the discomfiture of the Hun as their sole objective.²⁹

His tone may be excused, for he had had an exasperating war. Yet all the right was not on SOE's side in this prolonged and often heated controversy. If SOE had simply demanded passages into northern France, these could probably have been got without much trouble; but SOE was seldom contented to let well alone, or to be satisfied with an inch when an ell seemed to be there for the taking. F, RF, EU/P, and the naval section alike could hardly ever envisage a seaborne operation without wanting to carry arms, explosives, and wireless sets on it as well as men. The constant references to stowage capacity, in the survey of craft made a few pages back, reflect a continuing staff preoccupation. The staff's anxiety to land stores practically ruined its attempts to open up cross-channel seaborne traffic in agents; the anxiety only stemmed from a restless determination to hit the Germans hard.³⁰ RF's one circuit operating by sea, OVERCLOUD, early fell into German hands; this did nothing to lessen opposition by other secret services to operations of this kind.

No sea operations were ever attempted on the north French coast, east of the Channel Islands, under SOE's operational control; such possibilities as that much-occupied area afforded for clandestine landings were left to combined operations headquarters to explore. The irrepressible Harratt, of whom more shortly, was wounded as an observer at Dieppe;³¹ but that unfortunate operation was not SOE's.

In the Mediterranean, operations by sea were less difficult. SOE was able to share with other services, without any serious trouble, in clandestine operations from Gibraltar to the south coast of France; either by submarine, or by that curious craft HMS *Fidelity*, a heavily armed 1,500-ton merchant vessel, or more usually by felucca. A pair of twenty-ton feluccas crewed by some of EU/P's Poles, a gang of seamen described by Sikorski to Gubbins as 'too rough even for the Polish navy',³² did this kind of work in the western Mediterranean for two years with impunity, under two recklessly brave lieutenants called Buchowski and Kadulski (known to SOE as Krajewski), who both earned their DSOs. These boats were small and slow, and often exceedingly uncomfortable as well. Passengers had to be kept below, to maintain a face of innocence, whenever other craft were in sight; and there might be very little room – a journey with as many as eighty-nine passengers is recorded.³³ The round voyage to the Riviera hardly ever took less than

twelve days and in bad weather might take eighteen; this made feluccas unsuitable for urgent work, but they were more reliable than the state of their engines would suggest (one of them was powered by an engine out of an old SOE motor car).³⁴ They were too small to carry large quantities of stores, though they were used – as were submarines – to put arms and agents into Corsica in the summer of 1943.³⁵

A much more grandiose project, LAFITTE, for the landing of 500 tons of stores or more on the south coast of France, intended to produce one formidably armed resistance movement and evacuate a large number of Poles, did not get beyond the initial planning-stage: it provides an instance of the *folies de grandeur* that can assail senior staff officers who do not know enough about the details of what can and what can not in fact be done.³⁶

The German occupation of the Mediterranean coast of France in November 1942 made sea operations there much harder than they had been; for the occasions that might prompt a French gendarme to look the other way might impel a German sentry to open fire. Feluccas were taken off working to the French mainland, but a certain amount could still be done. French submarines made regular monthly landings south of St Tropez through most of 1943 and 1944; usually carrying agents for the various French intelligence and security services, but sometimes carrying people for SOE. The craft most used was the *Casabianca*, a submarine which escaped from Toulon the morning the fleet there sank.³⁷ She was useless for normal naval purposes (some obscure fault in her torpedo tubes always made her torpedoes travel in circles), but her carrying capacity was large – she displaced 1,700 tons, and once took an entire French infantry company of the *Bataillon de Choc*, packed cheek by jowl, from Algeria into Corsica overnight. Her captain, L'Herminier,³⁸ was ready to take risks, with his French crew, that the British submarine service would officially have shuddered at; and she played an important part in preparing as well as completing the liberation of Corsica. These submarines provided the one means open to the French authorities of 'external resistance' of communicating direct with France, with no more British or American co-operation or supervision than was involved in clearing them in and out of the north African ports in allied hands.

Normally, though, by submarine as by other carriers, transport of agents in and out of France was handled for the French by SOE; and after the clearing of Corsica MASSINGHAM threw out an advanced base onto the island, called BALACLAVA. Several successful sea operations were carried out from here by a commander who had had, even for SOE, a diverse career, Andrew Croft. Born in 1906, he had been at Lancing, as was fit for a clergyman's son; he was the first head boy of Stowe; he was three years at Christ Church; he was awarded the Polar medal in Greenland in one arctic expedition, wintered as ADC to a maharajah, and was back in the far north next summer on another; he had learned to fly and learned to ski, had more than a smattering

of ten languages, and was secretary to the director of the Fitzwilliam Museum when the war began. He had served in Norway as Gubbins's brigade IO, and reached BALACLAVA after some years' work in Scandinavia.³⁹ He once put a party of agents ashore on the landward side of a quay in Genoa harbour; so he did not lack nerve. But for work into France he frequently lacked opportunity, there are no indications that many agents were sent there from BALACLAVA by sea.

The catalogue of watery failures and near-failures in the Channel can be set off with an account of one undoubted success; a DF operation known as VAR, which ran an escape line of considerable efficiency across beaches on the north Breton coast in the winter and spring of 1943–44.⁴⁰ That VAR could begin at all was due to a piece of dexterous bypassing of the proper channels by Harratt, DF's GSO III in charge of seaborne projects; to the annoyance of the naval section, he went straight to DDOD (I) and sold his project successfully there. 'This crossing of wires is most aggravating', his opposite number minuted; but Harratt by then had scored his point.⁴¹ (It is a good illustration of SOE's divorce from normal service routines that this wrangle on a purely nautical matter was between a hussar captain and a flight lieutenant in the RAFVR.)

Up to six passengers could normally travel in each direction on a VAR sea crossing, if all went smoothly; and once in an emergency ten were crammed in for the journey back to England. Some seventy people were conveyed in all on the sixteen successful attempts. Another sixteen sorties were made without success – sometimes because of bad weather, sometimes because the beach was empty when the boat arrived, only once because of enemy interference. In that one case, on Christmas Eve 1943 – the same night as FELICITATE – the boat was seen close inshore on a particularly clear night, was fired on, and escaped unscathed; a German patrol was on the beach in a matter of minutes, but the score of people who had been waiting there had by then vanished without trace. The Germans on reflexion believed that the gunboat's voyage had been intended to divert attention from a FORFAR commando raid made, much farther east, on the same night. No passengers were lost on any VAR operation. The total casualties in fact amounted to one naval rating killed at the tail end of the last operation of all in mid-April 1944, which was fired on in a chance encounter with slow German patrol craft; two London-trained and six local agents arrested and deported, half of whom returned alive; and two men whose minds were unhinged by the strain of keeping the whole project secret.⁴²

Nearly one hundred and fifty people were concerned directly in VAR's activities on the French side, and about twice as many on the British; but the whole system was conceived, designed, and worked out by two men, one English and one central European. The Englishman, P.J. Harratt (*Peter*), had been a regular soldier in the twenties; had spent most of the thirties farming in south-west France; described his politics as 'anti-nazi'; and had fought

briefly on the republican side in Spain. Youngish as Harratt was – he had been born in 1904 – Erwin Deman (*Paul*)⁴³ was seventeen years younger still, a cosmopolitan Jew born in Vienna in 1921, in Lisbon on business as early as 1936, trilingual in English, French and German, and a great hater of the nazis whom he had fought with distinction, as a corporal in the French Army, in 1940. He had escaped to France from a prisoner-of-war camp in Germany, and reached England by joining the foreign legion and then deserting from it. SOE took him on at once; and after he had completed his routine training Harratt took him over. The pair of them shut themselves away for two months' intensive work in a small boat on the Dart; when they emerged they were both expert in chart work, compass work, beach recognition, and the technique of silent landings, and had mastered the use of the S-phone.⁴⁴

Some strokes of luck gave Harratt a start for Deman's first venture into France (MANGO). A staff officer's sister had an old nurse, Mme Jestin, who lived in Rennes; and Deman was equipped with half a sheet from a letter of the nurse's to England, to serve as an introduction. He was sent to France by Hudson on 19 August 1943, and made his contact at once. Mme Jestin's two unmarried daughters, energetic women in their early forties, entered with ardent enthusiasm into his plans. They organized safe houses, suggested further contacts, and arranged reliable guides and couriers; while he went off to reconnoitre the two beaches the rest of Harratt's luck had prompted. One of these, at Beg an Fry near Morlaix, Harratt heard of from the French proprietor of a west end restaurant; he had been told of the other by an F section agent, the Irish yachtswoman Cecily Lefort (*Alice*). Mrs Lefort's principal contribution to SOE was to suggest the use of the little beach below her villa at St Cast, west of Dinard⁴⁵ (her own career in the field, as courier to Cammaerts, came to an abrupt end after three months when a suspicious German asked her a question to which she had no answer ready; she did not return from Ravensbrück). As in the best fairy stories, she confided to Harratt, who passed it on to Deman, an ancient Irish ring, which would establish the bearer's bona fides if shown to the maid at her villa. Within eight weeks Deman had his organization ready, and himself established as an insurance agent in Rennes. Harratt flew over for a brief coded S-phone conversation with him, and the next stage began. Deman told his acquaintances he was taking a fortnight's holiday; took the VIC line back to England, via the Pyrenees and Gibraltar, in the record time of seven days; settled some outstanding-details with Harratt; returned to Brittany by sea (MANGO 4); and was in Rennes again on 29 October 1943, just two weeks after he had left.⁴⁶ His VAR escape route then began to work.

The actual conduct of a sea operation was straightforward. Passengers for it were assembled in France in the same unobtrusive way as for any other escape;⁴⁷ and brought just after nightfall to a convenient cottage near the beach. Passengers from the English side were briefed in London, and driven

down to stay with a conducting officer in one of several hotels near Torquay; generally under the cover of commandos on leave. When DDOD(I) and the naval Commander-in-Chief, Plymouth, had agreed that they could depart, they embarked, in uniform, during the normal naval visiting hours (noon to two) on the depot ship of the 15th MGB Flotilla at Falmouth and went straight below; five minutes before sailing time they and their water-proofed luggage were trans-shipped unobtrusively into the vessel that was to carry them to France. Before leaving, everybody was 'checked to make sure he neither rattles nor shines'.⁴⁸ The BBC warned the field in the usual way that the gunboat was coming – or was not, if the weather turned bad.⁴⁹ Plymouth command cancelled its nightly anti-E-boat sweeps whenever a VAR operation sailed; and the RAF provided continuous fighter cover during the hours of daylight. The air cover could not help being visible, and raised a security problem; as did the festoons of navigational and S-phone aerials on the MGBs. Both problems were solved by letting the tale leak out, locally, that the MGB flotilla was engaged in specially hush-hush wireless research: this seems to have been effective. Harratt even reported that the wife of one of the gunboat officers 'told her husband it was time he went and did something dangerous like other boys'. Moonless nights were always chosen; and sailings were so timed that the craft would not be within thirty miles of any enemy-held coast till two hours after sunset. When this distance was reached, said Harratt, 'the silencers were turned on to the engines and the speed consequently reduced. At a point fifteen miles from the enemy coast, main engines were cut and we went forward on auxiliaries in complete silence, at a maximum speed of approximately 6 knots. This reduced the wash and consequent phosphorescence.'⁵⁰

Close inshore, an exact drill had been prepared. No lights were shown at sea; nor was there any talking or smoking at all on deck (it required a stern effort of discipline to hold the French to this). S-phone contact was usually made; failing that, the beach party would flash an agreed morse letter from a hand torch, or signal with a luminous plastic ball held in the closed fist.⁵¹ The MGB anchored off-shore, by a grass rope – a rating standing by with a hatchet to cut it in case of alarm; the landing party were rowed in with muffled oars in a surf-boat, and carried the last yard or two ashore by sailors after Harratt had gone ahead to verify the reception committee's *bona fides*. Agents wore gas capes (taken back by the sailors) over their clothes to prevent spray stains. On the beach, agents 'should be briefed to behave as much like luggage as possible. While waiting they should always sit down except on first disembarkation when they stand by the boats. ... They should never contact the [outgoing party] and on no account may talk.'⁵² No one ever wore any headgear, lest it should fall off and so leave a trace of what had passed. Usually the MGB was at anchor for about an hour-and-a-half; Harratt reported 35 minutes as the shortest and three-and-a-half hours as the longest times at anchor he had known – in the latter case, the rowing

party's return was hampered by a sudden fog. The actual time spent by the seamen on the beach was only supposed to be three or four minutes.⁵³ Landings were made on a rising tide, to minimise footprint traces; and somebody from the shore party made a point of visiting the beach again at first light, to ensure that there was nothing suspicious to be seen.

By that time the incoming agents would be feeding or resting in the cottage where any departing agents had been collected; by mid-day they would be gone on their various ways. Aline the elder Jestin sister (*Jean*) worked in Rennes prefecture and had no trouble in producing as many blank safe conducts for the coastal zone as were needed. Felix Jouan, the miller of Bédée west of Rennes, provided a van in which the journeys to and from the coast could be made. In January 1944 Jouan was pulled up by a German policeman for having dirty number-plates; and the sharp-eyed constable, idly shining his torch into the back of the van, recognised suitcases in it as of SOE type. Jouan was arrested on the spot – his companion, Deman's beach lieutenant at St Cast, slipped away – but spun so plausible a story about an unknown man who had asked him to carry the suitcases for a favour that his own connexion with SOE was never divined. VAR had by then acquired so much momentum that Deman had no trouble in finding another driver; the circuit equally survived an indiscretion by a Quimper contact; but the alarm of Jouan's arrest forced the Jestin sisters to remove to Paris.

VAR did not long survive their transfer; for in the end, as happened often in RF and seldom in DF section, the circuit snowballed. Its activities grew wider, more people were involved, it ceased to be secure; and it had to be recast entirely. During the recasting, Deman fell by the wayside. He came back to England – using his own route – on 27 February 1944, taking with him Langard his excellent wireless operator (*Dimu*) and his beach lieutenant Sicot (*Jeanette*) a St Cast fisherman's son.⁵⁴ Langard and Deman returned to France, again by sea, on 18 March. VAR by now was getting out of hand; the Jestin sisters were spreading the network far and wide from Paris, with contacts in Brussels and contacts far down the Rhône valley; Langard had moved from Redon to Quimper near the south-west Breton coast, where local possibilities seemed excellent, and no one in the circuit could understand why operations to beaches in the Quimper neighbourhood were not feasible. As the short summer nights were bound to impose a check on sea crossings, Deman was again summoned to England for consultation: he returned once more on the last and most crowded VAR sea operation, arriving on 16 April. He was instructed in some detail on the need to keep his circuit from expanding too fast, and was sent back through Spain to take it over again from Louis Lecorvaisier (*Yves*), the discreet Rennes insurance agent who was in charge in his absence, and turn it into a land line across the western Pyrenees.⁵⁵ By now Deman's nerves were becoming severely frayed, and his equanimity did not survive a series of exasperating hitches in his journey across Iberia. Fortunately for everybody, his false papers were

lost by one of the guides early in his attempt on the Pyrenees, and he was recalled. Lecorvaisier, Langard, and Emile Minerault of OSS (*Raymond*) turned the VAR line into an efficient ordinary SOE land escape route during the summer; and OVERLORD overran it. Langard, it may be added in conclusion, was arrested while transmitting, on 26 June 1944; he kept silent under torture, thus saving his companions' lives at the cost of his own. He died in Buchenwald eight months later.

(B) AIR

Parachuting began in prehistoric Greece,⁵⁶ and in China in the fourteenth century. The Russians first demonstrated its offensive possibilities in their manoeuvres of 1930, by an airborne attack on a corps headquarters;⁵⁷ the clandestine implications were obvious. (Gubbins, then serving in the War Office, was shown a film of this attack by the Soviet military attache in London in 1931.) By the beginning of the war all the principal powers, and a number of the lesser ones, had the elementary equipment for dispatching secret agents by this means. Obviously it was a means SOE would use.

The cyclostyled form that many potential agents filled in when first being investigated included an inquiry about ability to fly an aircraft; but SOE never tried to form a private air force as well as a private navy. Throughout its life it depended, equally with other secret services and with the army's airborne troops, on the RAF and the USAAF for air lift. The inter-secret-service wrangles so prominent in SOE's naval affairs scarcely troubled its air policy. This was partly a matter of personalities: DDOD (I) had no air equivalent. In the very early days there were no air operations to ban, because no potential agents had done the short but practically indispensable training; once SOE had found its feet, it had the strength to override most bans except the Foreign Office's.

The Air Ministry was no more ready to have SOE operating independently by air than the Admiralty was ready to envisage it operating independently by sea; but Portal, chief of the air staff from October 1940, was happy to countenance activities under his own operational control that would assist SOE, and to provide at least a bare minimum of air facilities, provided this could be done without endangering grand strategy.⁵⁸ Up in the service stratosphere, there was often keen debate about how large a diversion from the rest of the war effort could usefully be made to help SOE. One passage from that debate may be quoted to illustrate the problems involved: a most secret note of Portal's laid before the other chiefs of staff on 25 July 1943, during one of the recurrent aircraft availability crises.

Desirable as it may be to maintain and foster SOE activities, we must bring the problem into focus with the whole strategic picture.

The issue is a plain one. As we cannot provide aircraft for the transport of arms and materials to Resistance Groups except at the direct cost of the bomber offensive, what is the exact price which we are prepared to pay? I suggest that the answer should turn ... on an impartial consideration of the present strategical situation.

We are unquestionably obtaining great and immediate value from the bomber offensive. For all that, the weight of our attack falls far short of what it should be ...

I have no doubt about the value of what is being done by SOE in the Balkans, or about the need to do as much more there as is possible. These activities accord with our general strategic plan, they exploit our present successes and should give us good and immediate results.

The same, however, cannot be said about the rest of Europe, where the efforts of Resistance Groups cannot be really profitable until next year. The real value which we shall obtain from these Groups will be an uprising. If such an uprising is to be successful – and it can only succeed once – it will demand conditions in which German resistance in the West is reaching the point of disintegration. We are not in a position to begin to apply the necessary pressure for another nine or twelve months unless the German war machine cracks seriously in the meantime. The most likely cause of this accelerated collapse is the bomber offensive which must not be handicapped by diversions to an operation whose value is obviously secondary.

Thus on strategic grounds, while I feel that there is a very good case for providing aircraft to back SOE activities in the Balkans, even at the cost, as it must be, of some small detraction from the direct attack on Germany, I feel that it would be a serious mistake to divert any more aircraft to supply Resistance Groups in Western Europe, which will only be of *potential* value next year, when these aircraft could be of *immediate and actual* value in accelerating the defeat of Germany by direct attack.

To pursue such lines of argument further would lead us too far from our subject of special operations in France; but mention of them may serve as a reminder of the place of SOE's French activities in the general context of the war.

What aircraft in fact were available for special duties? The RAF aircraft based in England for SOE's operations in north-west Europe are set out in the table on page 73, It will be seen that not till August 1941 were there more than five of them, a number raised to 27 by November 1942 and to a minimum of 37 by the spring of 1944.

When 419 Flight moved to Stradishall, administrative control over it shifted from 11 (Fighter) to 3 (Bomber) Group, which retained it till after France was freed; and an unobtrusive advanced base for the Lysanders was set up in a corner of the large fighter station at Tangmere near Chichester. This secured deeper penetration into France than was possible from the carefully camouflaged special duties airfield at Tempsford west of Cambridge.

TABLE I: RAF AIRCRAFT AVAILABLE FOR SOE IN ENGLAND¹

<i>Date</i>	<i>Unit</i>	<i>Aircraft Establishment</i>	<i>Airfield</i>
21 August 1940	419 Flight	2 + 2 Lysanders*	North Weald
September 1940	419 Flight	2 + 2 Lysanders, 2 Whitleys	Stapleford Abbots
9 October 1940	419 Flight	2 + 2 Lysanders, 2 + 1 Whitleys	Stradishall
February 1941	1419 Flight †	1 + 1 Lysanders, 3 + 1 Whitleys 1 experimental Maryland	Newmarket racecourse
25 August 1941	138 Squadron †	1 + 1 Lysanders, 8 + 2 Whitleys 2 + 1 Halifaxes, 1 Maryland	Newmarket racecourse
October 1941	138 Squadron	As above, but 1 experimental Wellington in place of the Maryland	Newmarket racecourse
February 1942	138 Squadron	10 + 2 Whitleys, 5 + 1 Halifaxes, 1 Wellington	Newmarket racecourse
February 1942	161 Squadron ‡	6 + 1 Lysanders, 4 + 1 Whitleys, 2 Wellingtons, 1 Hudson	Newmarket racecourse
1 March 1942	161 Squadron	As above	Gravley
11 March 1942	138 and 161 Squadrons	As above	Tempsford
June 1942	138 Squadron	4 + 1 Whitleys, 10 + 2 Halifaxes	Tempsford
June 1942	161 Squadron	6 + 1 Lysanders, 4 + 1 Whitleys, 2 Wellingtons, 1 Hudson	Tempsford
November 1942	138 Squadron	13 + 2 Halifaxes §	Tempsford
November 1942	161 Squadron	5 Halifaxes, 6 + 1 Lysanders, 2 Wellingtons, 1 Hudson	Tempsford
8 May 1943	138 Squadron	18 + 2 Halifaxes	Tempsford
1 January 1944	161 Squadron	5 Halifaxes, 9 + 1 Lysanders, 2 Wellingtons, 4 + 1 Hudsons	Tempsford
May 1944	138 Squadron	20 + 2 Stirlings	Tempsford
May 1944	161 Squadron	12 + 1 Lysanders, 5 + 1 Hudsons	Tempsford

Notes: 1 This table is based on *History, IXE*; on an undated twenty-page typescript history in Air Ministry file AHB II HI/86, top secret; and on 138 and 161 Squadron ORB's.

* i.e. two operational plus two in forward reserve.

† The same unit as before, re-numbered and expanded.

‡ New unit, formed from the king's flight; as there was too much work for 138 Squadron to do by itself.

§ Whitleys were no longer used for SOE's operations, though agents still trained from them.

By an informal arrangement 138 Squadron concentrated on dropping operations for SOE; while 161 handled the comparatively few other clandestine drops⁵⁹ and all landing operations, dropping for SOE also when it had aircraft to spare. Both squadrons took part also from time to time in ordinary bomber raids, or in other tasks that required their special navigational skills. In return, in the autumn of 1943 they were joined occasionally at Tempsford by Stirling squadrons of Bomber Command, seconded from bombing to special duty operations; Harris was ready to part for a time with his least effective

four-engined aircraft, less effective even than the Halifax as a bomber.⁶⁰ Lancasters were unavailable for SOE. At the end of the year two American special duty squadrons with Liberators and Dakotas came to stay at Tempsford for a short final polishing up of their techniques. These Americans moved early in 1944 to Alconbury, and later in the spring to Harrington, continuing their special work; and by a particular effort several score 3 Group and 38 (Transport) Group Stirlings and Albemarles were employed for supply dropping in February, March, and April 1944.⁶¹ Meanwhile a few of 624 Squadron's Halifaxes, occasionally assisted by American Liberators, had been dropping agents and supplies into southern France from Blida near Algiers. Lastly, in the summer of 1944, while major operations were in progress in France some mass drops of supplies were made to French maquis by large formations of the 8th USAAF, flying B-17 Fortresses.⁶²

For such abnormal, detailed, secret, and individual work as the transport of agents and clandestine stores, the ordinary air force procedures for operational control of masses of aircraft were manifestly unsuitable; special operations called for special devices. Originally the Air Ministry dealt with MO section of SOE; and in the earliest days MO might run the whole project, on the SOE side. More often, MO was prompted by a country section; and MO's successor AL never operated independently. This AL (Air Liaison) section dealt with a sub-section of the Air Ministry's intelligence directorate, AI 2(c). AL never dealt direct, officially, with Tempsford, Tangmere, or other airfields used by agents: this satisfied the air force's sense of the proprieties. AL did lay down, to AI 2(c), the relative priority of SOE operations when several were due to leave the same night. In working to France at least, there seem to have been no occasions when SOE was deprived of dropping aircraft to make room for flights for another secret service, though the early history of pick-ups was less smooth,⁶³ and occasionally SOE's requirements exceeded the available dropping sorties by as many as a hundred a month, nearly all of them for France.

Procedure for mounting and conducting an air operation was clearly shown in the film *School for danger*, made by SOE with RAF help at the end of the war, in which Jean Wollaston acted – as in real life – as controller in the Baker Street air operations room, which depended jointly on AL section and on D/R's office. The work of preparing these operations was shared between the country sections and AL, the former dealing with agents and the latter with the air force. Once AL had persuaded AI 2(c) to accept the ground, and the country section had arranged a BBC message⁶⁴ with the field, the packing station produced the stores; and stores, agent (if involved), and conducting officer all met on the airfield. Whenever an agent was to fly to the field, he or she inevitably felt that the occasion was, to put it mildly, exciting; but by the summer of 1943 everybody else concerned in England had got a smooth swift drill worked out. Some of the earlier efforts were not quite so smooth.

By 1940 the RAF had a handful of twin-engined Whitley bombers – unwieldy and ponderous aircraft, but with a range extending up to 850 miles – that had been modified to drop people by fitting a hole in the floor.⁶⁵ All a parachutist has to do is to jump through the hole; his parachute is opened automatically by a thin wire called a ‘static line’ which his own weight breaks. If he has been dropped from a judicious height – five or six hundred feet – and the parachute has been properly packed, the canopy has opened fully a few seconds before he reaches the ground. The landing shock is about the same as jumping from the top of a 14 foot (4.27m) wall; the trick of meeting it by a relaxed roll is quickly learnt. On a still night when all goes smoothly less than a quarter of a minute elapses between sitting in the aircraft poised for the jump, and standing on the ground beside the collapsing folds of silk.⁶⁶ The interval, though short, can hardly fail to be terrifying – till the parachute has opened; the next few moments contain one of the most exhilarating experiences open to mankind. Numerous agents’ memoirs bear witness to its delights;⁶⁷ but people did not join SOE for fun. As Piquet-Wicks wrote, ‘To be dropped in Occupied France was not a great adventure, nor was it an exciting pastime – it was a deadly struggle against a ruthless and savage enemy, most often with death as a reward.’⁶⁸ The details that follow must be read against this sombre background. Parachutists could jump through the fuselage floor of several kinds of aircraft – Whitleys, Albemarles, Halifaxes, Stirlings, and American Liberators and Fortresses; the Dakota, simpler still, had a door in the side of the fuselage from which it was comparatively easy to step out into space. (Agents only drop from Lysanders in fiction: in the teeth of the long-standing myth to the contrary.) Though the technique of dropping altered little during the war, safety standards do seem to have improved. Dewavrin found at Ringway early in 1941 that

the percentage of accidents, at that time about five in a thousand, seemed to us relatively disquieting ... Hardly had we arrived when we were taken out to the airfield ‘to give us confidence’. We watched sandbags being parachuted; a good half of the parachutes did not open, and the bags thudded onto the ground with a dull, flat noise that brought us no confidence at all. We looked at each other, rather pale – still, after all, some parachutes had managed to open; so we might be lucky.⁶⁹

Three years later Ringway students were given to understand that the rate of fatal casualties was about one in a hundred thousand, and were treated to no such uncomfortable demonstration; but this was only a more efficient way of inspiring confidence.

SOE’s French sections had a total of six fatal parachute casualties; none of them during training. Orabona, an RF wireless operator, was mortally wounded by a bad landing at night in July 1942;⁷⁰ and Escoute of the same section, on a liaison mission to some French trade unionists, was fatally

injured in January 1944 by being dropped too low.⁷¹ One Pole was killed on a drop a few weeks later; no details survive. Three other sergeant wireless operators were killed in the summer of 1944: two in JEDBURGH teams, Gardner of VEGANIN, whose static line had not been hooked up, and Goddard of IVOR whose parachute was faulty;⁷² and Perry of the second UNION mission, an American like Goddard, whose parachute never opened.⁷³ As the total number of SOE agents dropped into France was about 1,350,⁷⁴ who had done an average of say four jumps each, the organization's six fatal parachute casualties there turned out to be at the rate of about one in 900 descents; an improvement on what they showed Dewavrin. F section had none, nor did DF. Only five agents were lost on their way to a dropping zone in France. Jumeau on his second mission, and Lee Graham on his first, escaped from the wreck of their aircraft in April 1943, but were arrested soon after; and Jumeau died in prison. The other three were all killed in a Liberator shot down by anti-aircraft fire (also probably American) on 15 September 1944, when the fighting in France was nearly done, on a mission to the Vosges with the disagreeable codename of CUT-THROAT.⁷⁵

Lesser parachute accidents were much more common. The most serious happened to Mynatt of JEDBURGH team ARTHUR, who broke his spine, as his parachute did not open properly – presumably by the packer's fault. Agents normally went to the field fit enough to recover promptly from landing sprains; not all of them had the fighting stamina that carried Harry Peulevé over the Pyrenees on crutches after he had shattered a leg through being dropped too low in July 1942,⁷⁶ or took Mynatt with his broken vertebrae into a brisk infantry skirmish, during which he fell off a wall and broke some more.⁷⁷ Most low drops can fairly be blamed on the pilots; and pilot and weather officer between them were to blame for Sheppard (*Patrice*)'s landing on a police station roof in Burgundy in June of 1942. He was taken straight inside – the handcuffs were on him before ever he trod French soil. Eventually, after escaping from the Gestapo and being recaptured again near the Pyrenees, he found his way to Dachau; whence, his luck changing, he came back,⁷⁸ A more ludicrous accident is said to have overtaken another agent whose parachute entangled him in a tree: the wood was dark, the moon went in, and he could not climb down, nor judge his height – he heard nothing when he dropped things; so he waited for dawn. Dawn revealed a thick carpet of moss a few inches beneath his toes.⁷⁹

Stores also were liable to damage when dropped. They were packed either in rubber or fibre packages or panniers, or in metal containers. Packages travelled inside the aircraft, and were looked after by the dispatcher, who bundled them out into space just before or just after the agents who were his prime responsibility; or if no agents were jumping, immediately a light signal from the pilot told him that the run-in to the dropping zone was complete. Packages seldom weighed over a hundredweight. Something over twenty thousand packages and panniers were dropped into France for SOE

during the war, and nearly one hundred thousand containers were dropped as well.⁸⁰ There were two sorts of container; the C type, a single cylinder nearly six feet long containing three cylindrical canisters, and the H type, five separate cylindrical cells held together by a pair of metal rods while they dropped, (The H type was the invention of an ingenious Pole who thought it inconvenient and dangerous to cart an object the size of a man, weighing over a tenth of a ton, round enemy territory.⁸¹)

A wide variety of weapons, explosives, clothing, and comforts could thus be dispatched by parachute. SOE's sections working into France never tried to drop anything except skis that was larger than a container would hold. SAS several times succeeded in 1944 in parachuting both jeeps and six-pounder anti-tank guns, but these were held not to be suitable equipment for the comparatively amateur guerilla forces SOE was trying to get into action; SOE used nothing heavier than mortars and bazookas, and not many of them. Some details of the dispatch of stores will be found in Appendix C, together with some examples of the standard loads of aircraft that were prepared, in the light of experience, before the invasion of France and used extensively during the guerilla that was waged behind the lines of the main OVERLORD battles.

The packing of parachutes, containers, and packages for SOE became one of the numerous secret minor war industries. On the whole the work in England was well done. It has even been claimed that 'it was never possible to repack into a cell all the articles that had come out of it, so expertly had the packing been done'.⁸² The field complained now and again that the wrong stores had been sent, or none at all; such errors as were made were more often made in Baker Street than by the packing section or the air force, and only one bad blunder is reported; one circuit in trouble is said to have received a package of lampshades. And sometimes there were accidents, which derived from the nature of the stores that were dropped; containers loaded with hand grenades were occasionally known to burst on impact.⁸³ The packing staff developed marked *esprit de corps* and pride in their job, rejoicing over such successful coups as the parachuting of two hundred glass bottles of printers' ink for an underground newspaper in which not a bottle was cracked, or the preparing of ninety containers and sixty packages, all through one night, for an emergency delivery to Savoy on the night that followed. As it happened, in this particular case none of the six aircraft that took off on 14/15 March 1943 succeeded in dropping its load; half of what had been so hastily prepared was eventually delivered a week later.⁸⁴ This sort of accidental delay, maddening to field and aircrew alike, was common.

In North Africa the packing arrangements were far less satisfactory and the delays and disruptions of the dropping, programme were more frequent. Francis Cammaerts (*Roger*),⁸⁵ head of the highly successful JOCKEY circuit in south-eastern France, described MASSINGHAM'S packing on which he depended as 'shocking', and reckoned that more than a fifth of the supplies

dropped to him were lost, either because the parachutes did not open or because the containers burst, in the air or on impact.⁸⁶ Once he reported furiously to London that ‘at last delivery parachutes failed to open as usual containers fell on house and crushed the back of mother of one of reception committee this bloody carelessness absolutely inexcusable you might as well drop bombs stop relatives didn’t even complain but my God I do’, and London passing this on to Algiers observed ‘consider this situation very serious stop investigate and report’;⁸⁷ but there was no noticeable improvement. The comparative incompetence of North Africa’s packing station was presumably due to a poorer grade of staff than was available in England.⁸⁸ It can hardly have been the fault of the officer in charge, Wooler, an admirable Canadian ex-motor-car-salesman and former independent company subaltern, who went out to Algiers to organise parachuting arrangements after eighteen months as chief instructor at SOE’s Manchester parachute school. He made nearly three hundred jumps himself, many of them testing new equipment, and dozens of his pupils remembered gratefully how he had accompanied them as dispatcher when they went into action.⁸⁹

It was through air dropping that SOE ran into a supply crisis so grave that it threatened to bring operations to a temporary standstill: a shortage of parachutes.⁹⁰ SOE had to indent for them on the Air Ministry, and had difficulty in getting the air supply staff to appreciate the decisive importance of an adequate supply. In the summer of 1943 a sudden expansion of immediate demand from Yugoslavia, backed by prospective large demands from airborne troops that autumn, precipitated trouble; at the end of June parachutes were so scarce that SOE envisaged having to restrict drops. Efforts to use fine cotton instead of silk for parachute-making only raised further troubles of priority, as the same material was needed for balloons and for dinghies. The corner was – just – safely turned; no drops were cancelled for lack of parachutes. In November 1943 an inter-service Maintenance by Air committee was set up, on which SOE had voice and vote, and the organization succeeded in building up a reserve of parachutes at SHAEF large enough to sustain it through the heavy demands of OVERLORD.

Occasionally, early in 1944, it was possible to send parcels of vitally needed objects to the field in a hurry – bribes to release important agents from prison, drugs, wireless crystals to establish a new frequency for a critically placed set, and so on – packed in a single small container delivered by daylight by one of 418 Squadron’s Mosquitoes. But 418 was an ordinary Canadian intruder squadron, stationed at Ford near Tangmere; the system was less secure than the Tempsford one and was little used.⁹¹

Agents were quite often dropped blind – that is, dropped in open and, it was hoped, deserted country, and left to melt into the landscape as unobtrusively as they could. However, blind drops were frequently made some way away from the point previously agreed on between the country section, the agent, and the air force. Viewing the difficulties of low level navigation over

hostile territory by night this was not surprising; it could make large demands on the agent's versatility, for which he could get no previous training – security usually forbade the practice blind dropping of agents before they left Great Britain. The aircrew's and the agent's problems about finding out where they were might both be solved if the drop was made to a reception committee; stores were hardly ever dropped altogether blind, though early in 1944 numerous supply sorties were flown to areas known to be under maquis control by pilots borrowed from bomber command who did not hunt for precise pin-points.

The task of these committees bristled with difficulties before hand, and might develop even more after the drop. They had to light and to guard the dropping zone, to guide any agents who were parachuted, and to dispose of parachutes and stores without trace. Guarding and lighting were comparatively simple. Three men held torches or bicycle lamps out in a row, along the direction of the wind, in the middle of a flat space of open ground about half a mile across. The commander of the party stood with a fourth torch so that the lit torches looked from the air like a reversed capital L. When a distant rumble in the sky announced that an aircraft was near, all the torches were pointed towards it; the leader's torch flashing a previously agreed morse letter. Provided the aircraft did see the lights and the letter was correct, it released its load above them and was gone as soon as it could, so as to attract as little local attention as possible.⁹² It might carry an extra package of leaflets to be distributed over some nearby town to provide some cover for the low flight. Only disposal remained; this might take minutes or days. One agent claimed to have received seventeen containers, hidden that night, with only three helpers; they must have been titans.⁹³

The proviso about seeing the lights was important. If the torches were too bright they might attract French or still less welcome German police attention; if they were too dim, they would not attract the attention of the aircraft. In remote mountain areas, towards the end of the German occupation, it might be safe to use bonfires instead of torches, in spite of the scar a bonfire leaves on the ground; rash agents used them earlier.⁹⁴ S-phones, when available, were of some use in guiding aircraft towards committees, though not of much; they could be heard much farther than a hand torch could be seen, but not very much farther than a four-engined bomber could be heard; few pilots spoke French and by no means all agents spoke good terse English. The S-phone, first tested in October 1940 and improved by over two years' more research in a sub-section of SOE's signals directorate, was an early micro-wave wireless set for two-way voice communication between a moving ship or aircraft, bearing the master set with a 25-foot aerial, and a stationary agent on land. Ranges up to fifty miles by air and fifteen by sea were occasionally claimed for it; it was reliable within about half those distances, and conversations as clear as a local telephone call could be held with it when it was at its best. Moreover, it was difficult to intercept; and the agent's

end of it could be packed into a suitcase.⁹⁵ S-phones were normally connected up at the master set's end to the aircraft's intercom; sometimes with unexpected results. Once when an aircraft was hunting near Bordeaux for one of de Baissac (*David*)'s receptions, the tail gunner cried out that he had caught sight of the lights, and bloody awful they were; the reply came promptly from the hitherto silent ground, 'So would yours be, if the Gestapo were only a mile away from you!'⁹⁶ But the purpose of the airborne S-phone was not navigational. It provided a good and reasonably secure opportunity for coded conversations between staff officers based in London and important agents in the field; orders and valuable information could be exchanged in this way. The security of a circuit could sometimes be checked by flying across a staff officer who would recognise whether the voice he heard was that of the agent who purported to be speaking to him. (Drouilh, an invaluable officer on the French staff in London, was killed on such an operation in December 1943; thus disorganizing for some months liaison between RF and the field.⁹⁷) Late in the war an improved version of the S-phone was developed, which enabled quite lengthy conversations with an agent on the ground to take place at rather longer range, if technical conditions happened to be suitable; SOE did not use this system, at any rate in France.⁹⁸ Risk of attracting unwelcome attention on the ground grew with every minute the aircraft stayed in the neighbourhood, and in the second half of the war the Germans had the radar equipment to detect the aircraft and might always intercept it.

Needless to say, a heavy bomber in the act of dropping supplies, flying just above stalling speed with its flaps down, with almost all the crew's attention concentrated on the ground, was from a night fighter's point of view a sitting duck; particularly if the dropping zone was shut in between lines of hills, thus further reducing the pilot's chances of successful evasive action. Curiously enough there seems to have been no occasion in France when a clandestine dropping aircraft was thus caught in the act from the air; and dropping zones were always well out of the way of flak. The aircraft casualty rate in special duty dropping operations over France was what bomber command's historians call 'pleasantly low'; it varied between 1.5 and 3 per cent a year.⁹⁹

Nevertheless this special work called for special aptitude from the aircrew who did it: for concentration, endurance, and patience above all. And as the Air Minister put it at the end of the war, 'In difficult country the navigation risks were almost as formidable as the risks from the enemy.'¹⁰⁰ Their history remarks that

the difficulties of navigation were especially acute for the S.D. crew, the success of whose work necessitated pin-point accuracy on a small, often, ill-defined target after hours of flying across enemy country. The navigation, both on the journey and on the approach to the target, must obviously be of a very high order. Reception Committees were instructed

to choose sites for their dropping grounds which could easily be seen from the air; but for many reasons this was often not possible for them, and the aircraft, after having found its target area, might have to search for some time before discovering lights half hidden by a wood, or obscured in a valley ... the navigator nearly always had to rely on map-reading and D[ead] R[eckoning] and in order to enable him to do this, the pilot would take his aircraft across enemy-occupied Europe at a low altitude.¹⁰¹

In the middle of the war an improved radar device for locating landing grounds became available, called *Eureka*; it worked in two halves. One half was a beacon transmitter, which emitted an individual call sign as well as a constant (or intermittent) signal; this weighed nearly a hundredweight, but was just portable in a large suitcase and if well enough packed could be parachuted to the field and set up on a dropping zone. *Rebecca*, the receiving half, also an elaborate piece of wireless equipment, could be fitted in the navigator's cabin of a bomber; in the best conditions it could pick up the beacon from 70 miles away, and a skilled navigator could get within a few yards of the beacon with its assistance. *Eureka* and *S-phone* combined appeared able to do away with one of the principal obstacles to successful dropping – low cloud or ground mist.

This was too good to be true: the results in the field were disappointing. The main reason for the disappointment was undoubtedly that SOE's agents took too little interest in such delicate and complicated toys. Few of them were either navigators or theoreticians of wireless. They were anxious to get on with sabotage and secret army work, and their exuberant *je-m'en-fiche-isme* rendered nearly useless an expensive course of policy: 'a large proportion of the *Eurekas* despatched were never heard of again',¹⁰² and there do not seem to have been any instances in France of an SOE drop through cloud or haze using *Eureka* and *S-phone* in combination. The efforts made by SOE's staff, at the RAF's request, to establish a navigators' grid of particularly powerful *Eurekas* on French soil were equally ineffective. Earnest requests and peremptory orders to the field were alike disregarded: agents simply did not understand the importance of these intricate boxes of valves, and regarded them as tiresomely bulky liabilities, impossible to explain away to a snap control.¹⁰³ Equally, they did not appreciate the tactical advantages that would have followed the establishment of a *Eureka* grid, in the shape of far more reliable and more extensive supplies for themselves. Only a few of the desirable stations were manned; these at least were invaluable.¹⁰⁴

One other useful move was made on this front late in 1943. A number of suitable dropping zones called 'depot grounds' were equipped with *Eurekas*, and manned every night of every moon period (supply drops were normally only made between first and last quarter of the moon). Any aircraft which

could not find its proper reception committee could go to the nearest convenient depot ground instead, guided by Eureka, and drop whatever stores it was carrying there instead of carrying them back to base.¹⁰⁵ Even with a Eureka set at work, all the business of lights and loading parties had to be gone through as usual; and there were still a thousand and one chances of trouble.

The most probable source of trouble was the interception of members of the committee on their way to or from the reception; hence the care taken by some agents to forge themselves a gamekeeper's or doctor's travel permit, which allowed them to move about after curfew.¹⁰⁶ What with navigation difficulties in the air, and police difficulties on the ground, and the unpredictable weather that might cloud a dropping zone over in a few minutes, it is not surprising that some two-fifths of the sorties flown to France by special duties dropping aircraft were abortive. The proportion of successes for night operations rose as the war went on, from about 45 per cent at first, to 65 per cent, or two successes to one failure, in the first nine months of 1944. The daylight dropping operations of the USAAF after D-day, flown in large formations, had the high proportion of 562 attempted and 556 successful sorties; three aircraft were lost and three had to turn back.¹⁰⁷ About a tenth of the night failures were due, on the pilots' own admission, to inaccurate navigating; they could not find their dropping zones. Under 5 per cent were due to mechanical defects in the aircraft, for Tempsford's maintenance was good. Between a quarter and a third of the failures were due to bad weather, according to the time of year; so bad that either the aircraft had to turn back before it had reached the target area, or when it got there the dropping zone was obscured. The rest – half or two-thirds – were due to failure by the reception committee to put in an appearance at the same time as the aircraft; normally, as the airmen fully understood, for reasons outside the committee's control.¹⁰⁸

Even if aircraft and committee did both reach the ground, there might be troubles in the actual drop. Only the most practised pilots could gauge the height of their run-in exactly. If they dropped from too low, containers might be stove in on impact and agents might well be injured; and if the drop was made from even a trifle high, and there was any wind at all, stores and agents would probably be scattered. Wise reception organizers did their best to place one man at least as a long-stop well up wind of the dropping zone, to mark down where each parachute fell; with drops by moonlight, this was not difficult. A perfectionist would have two separate long-stops with luminous prismatic compasses, to take cross-bearings; but reception committees were seldom run by perfectionists. It was often a shock for newly landed agents, who had practised reception drill during their training in rigorous conditions of silence and security, to find themselves in a patch of countryside covered by men smoking, shouting, laughing and shining torches instead of creeping decorously from dark hedgerow to hedgerow; a

few drew their pistols quickly, and were only with difficulty prevented from shooting the friends they mistook for enemies.¹⁰⁹

Occasionally, when things had gone wrong enough in the field, agents were received instead by enemies they took for friends; this happened for example to France Antelme, Lionel Lee, and Madeleine Damerment east of Chartres in the early spring of 1944. They were dropped – a parachutist's nightmare – to an enemy reception committee, and were taken prisoner after a brief struggle; none of them returned. Even this rare sort of disaster – it happened to a total of eighteen F agents, on five occasions in all in France – was not necessarily fatal. Blondet (*Valerian*) shot his way out of a Gestapo reception, also near Paris, next June; killing one at least of the committee as he did so.¹¹⁰ Agents and stores could thus be put into enemy territory, given luck and skill, by parachute; getting agents out again by air was harder, but still possible.

One of SOE's air staff, tracing 'clandestine pick-up operations' back to Joshua's agents' visit to Rahab on the walls of Jericho, observed that 'aircraft were used fairly extensively for taking agents across the lines and back during the War of 1914–18'.¹¹¹ The far higher wing loadings and landing speeds of the forties put old precedents quite out of court; but SOE was good at working without precedents. As it happened an aircraft was available, to which Voltaire's remark about God has been applied; had it not existed, it would have had to be invented. This was the Westland Lysander, a small sturdy single-engined high-wing monoplane with a cruising speed of 165 m.p.h., and a radius of action, if stripped of arms and armour and fitted with an extra tank, of 450 miles.¹¹² It was useless for the purpose of army co-operation it had been designed to fulfil;¹¹³ but for secret pick-ups it was invaluable. It could carry two passengers easily, three at a pinch, or four in a crisis, besides the pilot; its all-up weight was about four-and-a-half tons; and it could land and take off over three or four hundred yards of firm grass or clover.¹¹⁴

After experience with Lysanders in 1941–42 had shown the feasibility of moonlit landings in open fields, in France, larger and more capacious twin-engined aircraft were also used; armed Lockheed Hudsons in 1943–44 and unarmed American Douglas Dakotas after D-day. In all, over a hundred successful pick-up sorties to France were made for SOE, delivering over 250 passengers and bringing nearly 450 out, for a total loss of two Lysanders, one pilot, and two agents. The successful sorties and landings may be shown in tabular form, with the numbers put into and brought out from France (see page 84).

Everyone who figures in the 'in' column of this table was a secret agent, and almost all of them belonged to SOE; on a few occasions advantage was taken of an SOE landing operation to infiltrate people from some other secret service. Most but not all of those who figure in the 'out' column were SOE agents also. But sometimes circuits hard pressed by the Gestapo did

TABLE II: SOE PICK-UP OPERATIONS IN FRANCE MOUNTED FROM BASES IN ENGLAND¹

Year	By Lysander (RAF)					By Hudson (RAF)					By Dakota (US)					Totals				
	Ops.	Sorties	People		Ops.	Sorties	People		Ops.	Sorties	People		Ops.	Sorties	People		Ops.	Sorties	People	
			In	Out			In	Out			In	Out			In	Out				
1941	1	1	1	1													1	1	1	1
1942	9*	10*	15*	19													9	10	15	19
1943	24	38	60	81	15	16	42	119								39	54	102	200	
1944†	9	14‡	26	28	10	13	52	77	13	20§	62	108	32	47	140	81	112	258	433	
Totals	43	63	102	129	25	29	94	196	13	20	62	108	81	112	258	433				

The table is derived from *History*, IXA, Appendix 5(i), amended from SOE file ANDY.

Notes: * Excluding one aircraft, carrying two passengers, shot down.

† To 9 September.

‡ Including one aircraft destroyed on ground after landing passengers.

§ Including one aircraft damaged in landing, hidden overnight, and repaired with stores flown out by later sortie.

not resist the temptation to send their womenfolk to safety in England, if room in a landing-operation happened to be available; and occasionally French politicians were carried who were needed promptly outside France, or whose age and health kept them from attempting the walk over the Pyrenees. It was never known for certain in London exactly who would arrive from a pick-up until the operation was over and the passengers had been identified. Pains were taken, at some cost in trouble and embarrassment, to make sure that new arrivals were who they purported to be, and not enemy agents. (The familiar allegation that one SOE circuit organizing these landings was directly involved with the Gestapo, which supervised its work, is handled in Chapter X.) The largest pick-up operation of all, when two score people were brought back to England from Limoges airfield by a pair of Dakotas on 2/3 September 1944, was designed to relieve the remnants of an SAS squadron that had been in difficulties; advantage was taken of this late opportunity to put in eight agents and over four tons of stores.

One difficulty about these figures must be confessed; they do not marry in easily with the figures of gaullist pick-ups published in Paris some forty years ago.¹¹⁵ These claimed that a total of 589 passengers had moved in and out of France by pick-ups under one form or another of BCRA auspices; 383 from RAF bases in England, 30 from Italy or Corsica, and 176 either from England or from north Africa, either in British or in American aircraft. Ignoring the 30 travellers between Italy, Corsica, and France, this would only leave 132 passengers from the total of 691 in Table II to travel by F's pick-ups; one F pick-up organizer alone, Déricourt (*Gilbert*), supervised 110 passengers, and F's actual total of passengers using F pick-up channels other than Dakotas seems, on the best available evidence,¹¹⁶ to be 147. A gap as small as 15 in some 700 travellers would alarm a travel agency, but need not seriously worry Clio; the BCRA claim may be slightly inflated, or the real F section figures may have been slightly misestimated. Roughly the proportion of passengers is clear: RF handled for the gaullists about four times as many as F.

Aircrew who baled out on ordinary operations were not normally handled by SOE's pick-ups; if they did not connect with one of the air escape services, they were expected to find their own way back through Spain. Among other accidental exceptions, one fortunate and bewildered young airman presented himself at the first French farm he came to after being shot down; by pure luck, it happened to be the safe house for an SOE landing operation that week, and the pilot breakfasted three mornings later in England where he set SOE's security officers a nice problem.¹¹⁷

Pick-ups were arranged and conducted in much the same way as drops; though the Air Ministry, intelligibly, insisted on stricter reconnaissance of the ground proposed, including a recent air photograph. The history of air operations goes so far as to say that 'A very high proportion of successful landing operations in Western Europe can be directly attributed to the work

done at Medmenham', the air force photographic interpretation station.¹¹⁸ The RAF insisted also, after one or two unfortunate experiences, that every agent in charge of a pick-up reception committee should have received specific training for the task, at a week's course instructed by 161 Squadron's pilots themselves. On this course agents learned the vital characteristics of a landing strip: a firm surface, a slope of not more than one in a hundred, and an absolutely clear space at least six hundred yards long.¹¹⁹ They and the pilots also learned to know each other. As stores larger than a suitcase were not handled, Lysander committees could be much smaller than dropping ones. In fact at a pinch a nimble outgoing agent could see the aircraft down on to the ground by himself; putting torches out beforehand, running round to light them after he had exchanged morse recognition signals with the aircraft, and collecting them before he emplaned. This 'operator-passenger' arrangement was highly secure, but took a minute or two longer than a normal landing and take-off; that is, the aircraft might be grounded for as long as five or six minutes.

For Lysander pick-ups, torches were arranged in an inverted L-shape; only three of them, with the crossbar at the upwind end, and the ground commander at the downwind light with the passengers and their luggage waiting hard by. The aircraft touched down just past this light, and as soon as it had landed taxied in a right-hand turn, round the other two, back to the first; there it turned upwind again and halted.¹²⁰ Luggage was handed out, or fetched out by the ground commander, if no passengers were coming in; passengers then disembarked and embarked, swiftly and silently, luggage followed into the plane; the ground commander cried 'OK', and the aircraft took off again within two or three minutes of landing.

With a light bomber the drill was much the same, though a kilometre of landing strip, more torches, and more time were needed; surprisingly few minutes sufficed. However, in quiet country areas, with the normal human carelessness of security, it was only too easy for word to get round that a pick-up was going to take place; quite a crowd might come to watch. Late in 1942 Peter Churchill found himself among a score of people who set out by car to see a Hudson down 'in the usual gay, carefree, noisy style of a charabanc load of football supporters returning after the victory of their side in the Cup Final'.¹²¹ Needless to say, the British did what they could to discourage such effervescence. The concluding paragraphs of the instructions given to agents conducting pick-ups are firm:

You are in charge of a military operation. Whatever the rank or importance of your passengers they must be under your orders.

There must be no family parties on the field. If the pilot sees a crowd he may not land. Ensure that at the moment of landing you and your passengers and NOBODY ELSE are on the left of Light A. and your Assistant on the left of Light B. Anybody anywhere else, especially

anybody approaching the aircraft from the right, is liable to be shot by the pilot.¹²²

Not even this ferocious warning always had effect. One of a pair of Hudsons landing near Toulouse on 5 September 1944 overran a couple of mere spectators and killed them: one, who deserved better fortune, was Colonel Parisot who had entered Toulouse a few days earlier at the head of George Starr (*Hilaire*)'s victorious Armagnac battalion.¹²³

Though 161 Squadron was stationed at Tempsford, its Lysanders usually went forward to Tangmere near Selsey Bill for operations, to save fuel and extend their range. One Lysander pilot had earlier served in a Spifire squadron at Tangmere, and was well known to the WAAF waitresses in mess; who clearly looked down on him, as they supposed he was no longer on operations (cover laid down that the Lysanders were for searching training). He could only grit his teeth in silence.¹²⁴

The interested reader will find in Appendix D (page 427) a clear account of how landing operations should be conducted, written for the guidance of other clandestine pilots by Hugh Verity, who landed nearly thirty times himself in France in 1943. Cowburn has published an equally lucid description of a pick-up from an agent's point of view.¹²⁵ Verity's secret account bears out all that is said in Tickell's published one about the care taken by the air force to do their job properly, and the amicable relations between pilots and 'Joes', as they called the agents. Again, as Verity points out, if the drill laid down was followed strictly there was practically no risk to anyone; nearly all the dramatic incidents derived from breaking the rules. As a cross-channel communications system, pick-ups did not run with quite the smoothness of the Golden Arrow; but in the peculiar circumstances of the day, they served their turn well. The speed and convenience of the service they could provide may be illustrated from an incident in October 1943: Heslop (*Xavier*) and Rosenthal were picked up by Hudson near Mâcon on the night of the 16th, made their report on the state of the maquis near the Swiss frontier, received fresh orders, and were returned to a field near Lons-le-Saunier two nights later by another Hudson, to carry on their organizing work; taking two Americans with them to strengthen their team, Devereaux Rochester as courier¹²⁶ and Denis Johnson as wireless operator.¹²⁷ As many as eighteen people were waiting to cross that night to England; a pair of Hudsons collected them all.

(C) LAND

Confusion and duplication marked the start of British attempts to organize land links with France and across it. Numerous informal and *ad hoc* escape lines sprang into existence in the autumn of 1940; some run by Poles, some run by Belgians, some in the charge of members of the British forces shot

down, or separated from their units at Dunkirk or St Valéry, some run and all supported by those of the French who were least prepared to accept the fact of German victory. Most of these lines ran either to Marseilles or to the Pyrenees. Over the Pyrenees there was a long-established smuggling industry, onto which the defeated Spanish republicans had recently grafted channels of their own, for people and correspondence, that ran to and from Bilbao and Barcelona. Franco did not sit easy in his new saddle at Madrid, and Spain was as much a police state as occupied France, Though the Spanish police forces had not the occasional efficiency of the German, they still presented formidable obstacles to the clandestine traveller. Moreover, according to the newly appointed British ambassador Spain was 'honey-combed with German agents' and the Germans and Italians were 'deeply entrenched in every department of the Government and in every walk of life'.¹²⁸ Portugal's regime was not much softer; but at least it was longer established, and did not owe its existence to recent German and Italian armed support.

Several SOE sections took an active interest in all this, and their activities overlapped both with each other, and with other British, French and Polish clandestine bodies jostling for position as well. Eventually the opening muddle was shaken out into some sort of order. Regular escape lines were established, and those that concerned SOE were all brought under the supervision of DF – originally a branch of F section – by the spring of 1942, At their busiest, some two years later, they were handling traffic at a rate of about an agent a day.¹²⁹

These lines worked with the usual appurtenances of secret service in fiction, except for the excitement, the gunplay, and the easy women; most of the time most of the agents led an extremely dull life, existing as calmly and discreetly as they could, busied with their cover employment as commercial travellers, booksellers, doctors, laundresses, or whatever it might be. Often neighbours were encouraged to think they were in a delicate state of health – gradual convalescence was one of the best of covers for someone like a wireless operator, though it would suit less well an organizer or a courier who had to be prepared to make long journeys at no notice at all.

The moral foundations of all escape lines are the same: steady nerves and complete discretion. The physical foundations lie in two things familiar to all who have worked underground: 'safe houses' and 'cut-outs'. Safe houses explain themselves; in them escapers could be hidden by twos and threes between the stages of their journey. Their essentials were thickly curtained spare rooms, no inquisitive neighbours, and access to extra ration cards. (The false papers section got so good at forging French ration cards that a revised version was once put into circulation by the Vichy authorities and by SOE on the same day.¹³⁰) A secluded garden was a luxury; but more than one exit was advisable, and a telephone was a necessity, for the working of the cut-out.

A cut-out is the nearest thing to a safe device in underground warfare: it is a means of establishing contact between two agents which, if it works

properly, affords the minimum for the enemy security services to bite on. One agent passes a message in a simple code to the cut-out; it might be to a bookseller, saying 'I have two volumes of Anatole France that need binding; can you arrange it for me?' The cut-out holds the message until approached by the next agent down the line, who rings up to ask, 'Have you any Anatole France in stock?', and will infer from the answer 'Yes, two volumes have just come in' that there are two escapers to be collected from the circuit's safe house in the Boulevard Anatole France; while the reply, 'Sorry, Mademoiselle, we're right out of stock' means there are no passengers that day.¹³¹ DF added a device of its own to make this fairly common message-passing system still more safe: a series of cut-out rendezvous, which divided each line into watertight compartments. Passengers would be taken from one section of the line by a guide who would leave them at a prearranged spot, usually a park bench, and go away. A quarter of an hour later a guide from the next section would arrive and collect them; never meeting her predecessor, whom the passengers would take care not to describe. This exposed nervous passengers to a series of *mauvais quarts d'heure* and depended on strict timing and discipline; but it worked well.

The safety of an escape line varied with the number of its cut-outs; ideally, they would intervene at every stage. An adequate cut-out system ensured that most individual members of the line knew at most only two telephone numbers or rendezvous, one at each end of their stretch of it; and even if the enemy raided these, they could get little out of them unless they happened to have the luck to arrive when passengers were present. Telephone subscribers might give away under pressure what form the next code message took, but could not say – because they did not know – from whom it came. Competent agents calling up a cut-out took care always to use café call-box telephones (not ones in post offices, for there one had to show one's papers), and to get away from the instrument promptly after making the call. Rendezvous were unlikely to be dangerous to a watchful guide.

A rather slower cut-out system could be worked through a poste restante with the help of a post office accomplice. For example, agents who wanted to return to England from the Swiss border would make their way to a safe house at Lyons; its owner would put them up for the night, and send a note with a friendly message on it, including a figure to represent the number of travellers, to Mlle Marie Labaloue, poste restante at a Lyons sub-post office. Mlle Labaloue was a polite fiction; the sub-postmaster and his wife, who sorted the post, put her note on one side. One of them slipped round the corner to a cobbler's or a cleaner's, and left the note there. The cobbler put a particular shoe, or the cleaner put a pair of stockings, in one corner of the shop window. A courier walked past both shops towards mid-day; if either were showing the signal she called in for the letter, and removed the escapers – with due precaution – to the next safe house. The system was reasonably watertight; and could be extended in several directions.¹³²

The VAR line for instance could get in touch with VIC by writing to the equally fictitious M. Jean Denier at the same address; if in a hurry, they could use a telephone cut-out who worked in either direction, a doctor at Issy-les-Moulineaux just outside Paris. The doctor had a busy suburban practice; no one else noticed that someone from VIC and someone from VAR rang him up daily for months on end, in case either line wanted to pass a message or a passenger to the other.¹³³ The cut-out system proved its worth on the one occasion when a DF line in France was dangerously penetrated. A German agent was recommended to the line in all good faith through a section from another country, and travelled down it from Brussels through Paris to Lyons; everybody he stayed with, and the courier he saw most of, were eventually arrested, but none of the cut-outs were touched; the line beyond Lyons remained intact; and indeed its working up to Lyons remained intact also, because a duplicate and a triplicate network of safe houses and cut-outs, both independent of each other and of the first network, had been established already.¹³⁴ All that was necessary was to warn London (and through London, agents already in the field) which of the alternative networks was now to be brought into use.

The initial contact was the dangerous point for an escape line, There might be a score of agents in the field at once, all carrying in their heads the same address and the same password. If one of them capitulated fast and entirely to the enemy, and a particularly brisk enemy intelligence officer saw and seized his chance, an enemy agent might be fed onto the line, and might travel along it for some way before an identity check caught up with him. This risk had to be taken, and was justified in the event: German intelligence never found out enough about DF's lines to exploit its knowledge far.

Passwords were always very simple, so that they could easily be memorised; at the simplest, dropping a couple of words – 'black stone', for instance – into a conversation.¹³⁵ More often, there was a short catch-sentence to be used as an introduction, to which the contact would make a prearranged reply: 'I come from – Victor'. 'You mean – Hugo?'¹³⁶ This guaranteed to each side the good faith of the other, and was usually all the introduction that was needed; though as an extra precaution wireless contact with London was normally maintained, and if the least breath of suspicion rested on someone who purported to be an agent London could provide a catch question that should establish whether he really was.

Agents travelling on DF's lines were expected to put up with fierce rules designed to secure their safety, and the working members of the lines had fiercer rules still. VIC's Paris sub-organizer listed them thus:

Members were only known and referred to by their pseudos.

Domiciles of the regular staff of the Circuit always remained secret.

New members of the Organization had to drop all previous clandestine activities.

All regular members had to sever contact with their families, and live at a domicile different to that where they had lived before being in the Circuit.

It was strictly forbidden to carry any papers or notes giving names of contacts, or addresses.

Verbal messages between Informant and Organizer through couriers were always given in veiled language which couriers could not understand.

When messages could not be put in veiled language or could not be remembered by the courier, it would be written on thin tissue paper, inserted into a cigarette, or carried in such a way that it could easily be eaten or dropped.

Passwords had to be given, word perfect, otherwise they would not be accepted.

Bodies in safe houses were not allowed to go out at any time under any circumstance.

Members were warned never to call on any safe house, without first checking the security of the house by telephone.

The following meeting places were out of bounds to all members of the Organization. Certain metro stations, public places such as Black Market restaurants, or bars and cinemas.¹³⁷

The second-in-command of the line added two more: “‘Safe houses’ will not be accepted if there are any children’, and ‘When carrying incriminating documents – accomplish the clandestine mission forthwith before any personal and innocent work.’¹³⁸ A simple inversion covered the telephone inquiry about whether it was safe to call; if the coast was clear, the safe house keeper said it would not be convenient to be called on, and the phrase ‘By all means do come’ meant ‘The Germans are here’.¹³⁹ With all these precautions, the VIC line was well enough protected; though Humphreys once wrote that ‘I am the last person to maintain that the security of my representatives in France is anything like perfect.’¹⁴⁰

He said in the same letter ‘As 99 per cent of the agents that I have to bring out of France are unknown to me until they get into trouble and have to be rescued, and as it is my sad experience that 99 per cent of all agents get into trouble through their own silly fault, I could never ask you to assume anything about their discretion except that it is of a low standard.’ He probably wrote under the irritation of bringing out some of the coup de main parties, more swashbuckling types than the general run of agents and a worry to all who had charge of them: they only grudgingly accepted the need to stay indoors lest they risk the lives of their hosts, and sometimes were undisciplined enough to insist on going out – with consequential arrests.¹⁴¹

All escapes contain a dramatic element; some were plain melodrama. George Starr, F section’s chief organizer in Gascony, was once waiting for

an appointment near the till of a busy café in Toulouse, full among others of Gestapo officers in plain clothes – SOE rather favoured this kind of rendezvous for agents; it was unlikely to excite suspicion. Just as a waiter appeared from the back with a tray of drinks, two weary men in blue battledress came in from the street and walked up to the cashier; one said with a loud and strong English accent ‘Nous – officers RAF – pouvez-vous nous aider?’ The waiter promptly dropped his tray; by the time the ensuing brouhaha was over the air force officers had been spirited out of sight. Starr was not surprised to be asked later that night to do something about them; and not sorry to pass them out of France promptly through a nearby contact with a sub-agent of VIC’s, for men with so little idea of security were a menace. Unluckily, the pilots’ rapid return to England caused the café to be reported round the RAF as a ‘safe’ address, and several more aircrew turned up there later to test the proprietor’s ingenuity in keeping them away from his German customers.¹⁴²

The actual frontier crossings, over the Flanders plain or through the Ardennes, the Jura, the Alps, or most often the Pyrenees, were usually undertaken with a guide. The normal guides were smugglers, who had no use for established authority either side of the border, knew the ropes thoroughly, and – if paid promptly and in full – were quite secure. VIC, the biggest line, worked with them through *Martin*, a former general in the Spanish republican army. Hugh Dormer, who twice used VIC without ever meeting its leader or knowing its name, wrote a powerfully evocative account of what a Pyrenees crossing in smugglers’ hands could be like – ‘Hell on earth.’¹⁴³ But round the fringes of their organizations hovered shadier and less competent characters. Some of these people, the flotsam who drift to the edge of every questionable situation, were out for money under false pretence of local knowledge, and ready to betray impecunious travellers to the wrong side’s police.

Sensible agents kept clear of these quacks.¹⁴⁴ But even a contact provided by a reliable SOE source might break down, as Millar discovered during his escape from a German prisoner-of-war camp;¹⁴⁵ and a determined agent might have to find his own way across the Pyrenees, as Sevenet (*Rodolphe*) managed to do in April 1943. He got into Andorra over the Col de Siguer, walking for eighteen hours, sometimes through waist-deep snow; once there, a non-SOE escape organization quickly took charge of him and passed him on.¹⁴⁶

However, the usual form was simpler; an account of an actual crossing by the VIC organizer may be worth quoting at some length:

On the night of the departure, the party is grouped in one of our safe houses, where they receive the final briefing on behaviour en route, what they have to say if caught, where and when they will change over couriers or guides, etc., etc. They leave Lyons by the night train. They arrive at Narbonne early in the morning, about 7 o’clock. The courier who accompanies the party is met at Narbonne by one or two of *Martin’s*

people. The decision is then made, whether they are to go straight through to Perpignan or round the Carcassonne-Quillan route. When they arrive in Perpignan, according to circumstances, they are either taken to safe houses or to the park. In the evening, when they are to leave Perpignan, they are taken out of the town by one of *Martin's* men, who meets the guides outside the town. They then put on their sand shoes and start on their night's walk. The following morning, having gone through the Zone Interdite, at a pre-arranged meeting place somewhere south of Ceret they meet two other guides, to whom they are handed over. They then continue during the day walking and resting. The guides carry food and wine for the party. The actual crossing of the frontier is made in daylight, but the guides are very careful, one of them remaining with the party, the other acting as a scout. The same evening, that is the evening of the first day, they meet the Spanish guide, who takes them through the Frontier Zone on the Spanish side. About 11–12 o'clock they arrive at a farm, where they rest and feed for the rest of the night and the following day, and then set off for Figueras. The car is usually brought to the party a few kilometres outside Figueras, and then they are taken into Barcelona ...

When the parties come through on the auxiliary line it usually takes them longer, but the going is not so difficult. As I came through on the line myself this time, I was able to note with satisfaction that the guides are very thorough. The food question has improved considerably and I do not think any of the men can complain that they go hungry. A safe house is provided on the Spanish side. What we will require, and I am confident we shall have before the nights get shorter, is a safe house between Perpignan and Ceret, as during the shorter nights it will be impossible to do that journey in one stretch. The actual time, within a few hours, from Perpignan to Figueras, where the car is taken, is about 30 to 35 hours; actually walking – 22 to 24 hours. The longest stretch is from Perpignan to Ceret – about 12 hours. The most dangerous part is between Ceret and the time when you are handed over to the Spanish side of the frontier; and the most difficult part is the walk through the Spanish Frontier Zone.¹⁴⁷

The best of DF's lines did not involve much arduous walking. Gerson took care to run most of VIC's crossings from Perpignan, where the mountains are reasonably low.¹⁴⁸ There was one way across, in the early days, which was almost absurdly easy, given the right guide, local clothes, and a relaxed temperament. The escaper took the train, with his guide, on Sunday afternoon to the mountain station of Latour-de-Carol, five miles short of Bourg-Madame. They left the station and strolled a few hundred yards up to the frontier, where by village custom several score French and Spanish people gossiped for a couple of hours every Sunday afternoon. When people began to drift away, the escaper walked quietly off with the man his guide had been chatting to – a Spaniard who was his guide for the next stage of his journey,

through Puigcerda to Barcelona.¹⁴⁹ This was too good to last; it ended when the Germans took all southern France, spread their *zone interdite* along the Pyrenees from sea to sea, and patrolled all the likely crossing-places. DF continued to pass people through by unlikely ones.

Once in Spain, agents were still far from base; if they fell foul of Franco's police they might spend many months in the noisome great camp at Miranda de Ebro¹⁵⁰ or elsewhere before they could get a false identity established to the satisfaction of the British consular and Spanish police and diplomatic authorities. Chalmers Wright, for example, was pinned in various prisons from early March to late June 1943, with a mass of deteriorating information he was unable to transmit.¹⁵¹ But if they were in the hands of a competent line, such as VIC, a guide would see agents right through to the doorway of the British consulate in Barcelona, whence steps could be taken to move them through the embassy at Madrid to Gibraltar, travelling openly (with forged identity papers) in diplomatic cars as 'escaped allied prisoners of war'. An energetic walker who could get to the small mountain terminus of San Juan de las Abadesas, south-east of Puigcerda, in time to catch the 4.10 to Barcelona was also likely to reach the consulate unhindered, as the police were too lazy to control a train so early in the day; though one agent who just missed it was arrested there at 4.30 a.m.¹⁵²

For some agents travel on consular facilities might be undesirably public; there were several clandestine lines across Iberia, of varying efficiency, that could be taken instead. And an exceptionally resourceful agent might be able to make his own way right across Spain to Gibraltar: this was apparently done in 1942 by EU/P's Dzieřgowski.¹⁵³ The ease of open transit across Spain varied of course with Spain's foreign policy.¹⁵⁴

Switzerland, the other neutral country bordering France, followed a policy of genuine neutrality, and its government was not corrupted by infiltrated agents of either side. If the Swiss authorities discovered an illegal entrant he was quarantined for three weeks, and then set free – within Switzerland – unless he had committed some offence more heinous than illegal entry. If he was an SOE agent, it was DF's job to move him back to England so that he could get on with the war; agents were established under various covers at Berne, and soon set up lines which ran through Lyons and Toulouse into Iberia. Some of these were 'body-lines' – that is, people travelled by them; others, which played a significant part in the war effort, carried Swiss machine tools needed by the British armaments industry. But to study the delicate task of their transport would lead us too far from subversive operations in France.

(D) BY SIGNAL

An ingenious biographer of a secret agent once suggested that clandestine circuits are better off without signals apparatus, which only draws the

enemy's attention.¹⁵⁵ This may be all very well for an intelligence network handling material which is not of day-to-day importance; but for SOE's main purposes to be cut off from frequent wireless touch with base was normally to be emasculated. Raiding parties could do without wireless; but no long-term circuit work was feasible without prompt means of keeping in contact with London, and few circuits could arrange this by courier. A good deal of time and effort was expended at Beaulieu in teaching agents how to send coded messages in apparently innocent letters or postcards to a memorised neutral address, and some dabbled in secret inks; but wartime posts were neither fast nor secure. Coded postcards were expected to be useful as a means agents in hiding could use to let base know where they awaited collection by a DF courier; but for operational purposes the post was demonstrably futile.

Wireless was not. What Gubbins once described as 'the most valuable link in the whole of our chain of operations' consisted of single agents with short-wave morse WT transmitters, communicating from the field to stations in the home counties in cipher. 'Without these links', Gubbins added 'we would have been groping in the dark',¹⁵⁶ but with them – and SOE had over 150 of them in France by June 1944 – plenty could be done.

This is not the place, and this writer has not the knowledge, to discuss the techniques of clandestine wireless communication. A brief attempt will be made in the next few pages to indicate the tactical elements of wireless contact between France and England, from a layman's rather than an operator's point of view. It is important to remember that in SOE's day in France the modern techniques of communication by microdot and by high-speed transmitter were unavailable. Nor could voiced exchanges take place except over short ranges by S-phone.¹⁵⁷

The tool of the ordinary SOE wireless operator was a short-wave morse transmitter, or rather a transceiver – that is, a transmitter and receiver combined. The type generally used by operators in France was called the B mark II; it weighed thirty pounds, and fitted into an ordinary smallish suitcase some two feet long.¹⁵⁸ Its frequency range was quite wide – 3.5 to 16 megacycles a second; but its signal was weak, for a set so small could not produce more than 20 watts at the best.¹⁵⁹ It needed moreover seventy feet of aerial, well spread out, and likely to catch the eye of a policeman looking for it. Exactly what frequency the set worked on was determined by removable crystals; every operator needed two crystals at least, one for day and one for night work, and might have several more. Crystals are delicate, and can easily be broken, in transit or if they are dropped; and they share with transceivers another disadvantage: they are practically impossible to disguise as anything else. They are at least small enough to lie on the palm of the hand, which makes them comparatively easy to conceal, by wrapping them up in something like a pair of pyjamas. But even the smallest transceiver ever available to SOE in France, the A mark III, which measured about ten

inches by seven by five, was too bulky to be so simply hidden;¹⁶⁰ and if a transceiver was discovered in a search, only luck would enable the holder to bluff his way out of imminent trouble. A few fortunate operators were able to persuade stupid policemen that they were carrying dictaphones or some kind of cinema apparatus; one correctly judged the characters of the two types who had made him open his suitcase and bought their silence for a thousand francs each.¹⁶¹ Another, more flamboyant, is said to have looked the German who stopped him straight in the eye: 'Je suis un officier britannique, voici mon poste de radio'; he received a cheerful 'Va t'en donc' in reply.¹⁶² A woman operator, stopped by a couple of Feldgendarmes at a snap road control in the country on the only occasion she ever had to travel with her set – it was on the carrier of her bicycle – laid herself out to be charming to both of them; each made an assignation with her; neither remembered to look at her suitcase; and she never saw them again.¹⁶³ But an expert could spot a normal transmitting set the moment the case it was in was opened. To meet this difficulty, the camouflage section produced a few sets disguised as ordinary household receivers;¹⁶⁴ but this disguise would hardly deceive for a moment anyone who took the back off the set and knew what he was about.

Security troubles for the operator might arise also if he ran his set off the mains. The German intelligence service's wireless direction-finding (D/F) teams were numerous and efficient, probably better than the British, for whom Langelaan claimed that if ever an unidentified transmitter was heard 'in a matter of minutes a first, rough direction-finding operation had been accomplished. If the transmitter was anywhere in the United Kingdom, in less than an hour experts equipped with mobile listening and measuring instruments were converging on the region where it had been located.'¹⁶⁵ French operators in the field early discovered that a long transmission in a large town would probably bring a detection van to the door within thirty minutes.¹⁶⁶ The Germans soon worked out a technique for establishing what part of a town a clandestine operator was working in, by cutting off the current sub-district by sub-district and noting when the clandestine transmission was interrupted; then they could concentrate their efforts on the sub-district affected, and hope to track down quickly at least the block, if not the apartment, the set was working from. There were several counters to this: posting a protection team, who would warn the operator to hide at the approach of a D/F van, or even of a man sauntering down the street with his collar turned up, in case he was a Gestapo agent with a miniature listening set held to his ear; transmitting from an isolated spot in the country, instead of in a town; or using an accumulator instead of the mains, though this raised a problem of its own: how to keep the accumulator charged. The best protection of all, better even than constant changes of crystal during a transmission to confuse the enemy, or constant changes of the place of working, was constant attention to brevity by the writers of messages. The less a

set was used the less chance there was that D/F teams would pick it up. In the heroic early days an operator might spend several hours a day at his set: almost all the early operators, as a direct result, were caught. People grew more wily later. Yet as they had to spend less time hammering away at their morse keys, operators began to take more interest in the other affairs of their circuits, this brought different dangers. In retrospect, the security section laid down that 'The ideal is for the W/T operator to do nothing but W/T work, to see his organizer as little as possible, if at all, and to have contact with the fewest possible number of the circuit.'¹⁶⁷ But this was bound to lead anybody who was not exceptionally self-reliant to the verge of distraction from boredom; which in turn might drive him to do things that would expose him unnecessarily to the enemy.

This was a lasting difficulty. Another, graver one was only temporary: it was that wireless communications with the field were not at first under SOE's own control. Of course SOE like any other user, however secret, had to secure through an interservice frequency board a wavelength allotment; a merely technical point. Much worse trouble arose from what various high authorities supposed to be the case when SOE's work began: that the obstacles in the way of clandestine wireless communication with the continent were so complex that they all needed to be handled through a single group of staff officers who were outside SOE altogether, in SIS, the body whose task it was to secure intelligence from enemy and enemy-occupied countries. Relations between these officers and their superiors on the one hand, and the staff of SOE on the other, were notoriously strained, particularly during SOE's first two years. A lucid sketch of the dangers and difficulties that arose for another secret service in a comparable situation has been published by Dewavrin; who brings out also the deadly combination of inertia with incompetence that he found he had to fight.¹⁶⁸ In the end, it was agreed in the light of experience that SOE could and should run its own wireless affairs; work, indeed make, its own sets, train its own operators, invent its own ciphers, and do its own deciphering. A signals directorate assumed full powers from 1 June 1942.

Having secured full control of wireless on the home front, SOE's high command was disinclined to part with it to agents in the field. The visionary scheme for creating a French secret army over a quarter of a million strong that André Girard (*Carte*) dangled before F section in 1942 included a proposal to equip that army with wireless sets for internal communication. Like many of his ideas, this was a grandiose conception insufficiently worked out in detail; and though he engaged Bodington's enthusiasm for the plan¹⁶⁹ nothing came of it. For it ran clean against every principle of sound clandestine organization; and it raised special complications about cipher of its own. F did send a number of sets out to the Riviera by felucca that autumn, to be used in this scheme if it ripened; Cammaerts, the only man to get much work out of any part of Girard's following, later found himself with thirty

of them to look after, but they were already almost useless with damp and neglect, and he left them severely alone.

The whole business of encoding and enciphering wireless traffic with the field was naturally both complicated and highly secret and I have made no attempt to pursue it in detail. Instead I refer interested readers to Leo Marks's *Between Silk and Cyanide*,¹⁷⁰ subtitled 'The Story of SOE's Code War', in which they can read the coding officer's only too precise descriptions of the faults that attended the poem code system SOE had taken over from SIS, and how Marks arrived at his great professional triumph: he reinvented one-time pad, an unbreakable coding system first invented by the Germans in the 1920s.¹⁷¹ The Foreign Office had been using it all through the war, without of course mentioning it to SOE.¹⁷²

Mark's account of Baker Street is a good deal less comfortable than others in print; perhaps because he felt so out of place there. He was conscious that he was unusually bright, in circles in which brightness by juniors was rather frowned on. Moreover, he was a young Jewish civilian, who felt himself despised by the army officers who were his seniors in the signals section, and in the country sections on which he found he could exert little influence. It must be admitted that there were plenty of mild anti-semites in the British middle and upper classes of the early nineteen-forties; though their anti-semitism was a long way away from the Judaeophobia that impelled so many nazi and Arab atrocities.

From the late summer of 1943 the bulk of SOE's W/T operators in the field had one-time pads, and were therefore safer than their predecessors had been; but the French continued to use, for political traffic into France, codes which on one celebrated occasion the British were able to break practically at sight;¹⁷³ Marks even thought that 'every message' the French sent in their own codes 'can be read by the Germans' as late as the end of March 1944.¹⁷⁴ As one-time pad is now public knowledge,¹⁷⁵ a summary account of it can turn no one's hair grey; the agent held a pad of silk slips, each printed with columns of random letters or figures from which any message could be enciphered or deciphered; he used the slips in the order he found them on the pad, and was supposed to tear each slip off and burn it after use. Home station held the only duplicate. The only snags SOE's operators found in this arrangement were that the silk was hard to burn and that home station sometimes referred to messages a fortnight old.¹⁷⁶

But how did the Paris SD come to know anything about SOE's cipher arrangements, and try to play back captured sets? Details will be found in the narrative below;¹⁷⁷ but a few more words of preface about wireless security may be useful. The best way to keep clear of the efficient German direction-finders was to transmit seldom, briefly, at irregular intervals, at various wavelengths and from various places. This was common sense; but SOE agents were not always able to work commonsensically. For instance, according to a French friend and neighbour who survived, as late as midwinter

1943–44 Yolande Beekman was committed to the imprudence of transmitting from the same spot at the same hour on the same three days of the week for months on end,¹⁷⁸ it is not surprising that her journey to Dachau began with the detection of her set. Why did she do something that must have run counter to her training? Presumably because she and her organizer agreed it was safer to use a well-hidden transmitter in a reliable house than to risk the dangers involved in finding other transmitting stations and other sets to work from them. The mistake was fatal. Yet not all the blame for it was theirs; London might have introduced earlier the more flexible operators' timetables (known as schedules or 'skeds') that were common form by next summer. These revised programmes made direction finding much harder, at the price of further complicating the operators' already intricate tasks. One of the security staff, who maintained that 'more casualties are caused by detection of wireless operators than by penetration by agents provocateurs', minuted in September 1943 that 'one of the main causes of our casualties is being removed by the new Signals Plan';¹⁷⁹ but it took a long time to set up, and valuable agents were forfeit meanwhile.

Once an operator did fall into enemy hands, he should have been able to warn home station that he had done so, through a system of security checks. These again were individual to each operator, and usually consisted of a deliberate spelling mistake or series of mistakes: the seventh letter of the text wrong, or every twelfth letter replaced by the letter preceding it in the alphabet, for example. The Germans soon knew, and SOE soon knew that they knew, about this arrangement; thereafter every operator took a double security check with him, a bluff check that he could confess to the enemy if pressed hard enough and a true check to keep to himself. The deciphering staff knew which checks each operator was supposed to use, and indicated whether their use was correct; so that a country section staff officer faced with a message marked 'bluff check present, true check omitted' might well conclude that the agent who sent it was under duress.

Unfortunately, things did not work out anything like so smoothly. To start with, wireless reception from the field was often so bad, or so badly jammed, or the operators' morse so unsteady, that not even an expert decoder could always tell which of the myriad mistakes were intended and which were accidental; and not all the decoders were expert. It is important to remember how many steps a message had to traverse before it reached the responsible officer's desk in London: encoding, transmission, reception, decoding, teleprinting – each of them steps that might bring errors with them. Country section staffs always sought to receive each message exactly as decoded, and to prevent the signals and cipher staff from altering the sense of what they handled by any sort of guesswork, however inspired. Where the sense was immediately plain, the decoders broke messages up into words; otherwise they left a jumble of letters and figures. Here is a simple example of the sort of thing that confronted the staff: a deciphered

telegram from *Mackintosh Red*, Peulevé's set in the Corrèze, about events over 250 miles away.

TOR 1028

12TH MARCH 1944

BLUFF CHECK OMITTED

TRUE CHECK OMITTED

73 SEVEN THREE STOP

FOLLOWING NEWS FROM ROUEN STOP XLAUDEMALRAUX DISAPPEARED BELGIVED ARRESTED BY GESTAPO STOP RADIO OPERATOR PIERRE ARRESTES STOP IF CLETENT STILL WITH YOU DO NOT SEND HEM STOP DOFTOR ARRESTES STOP EIGHTEEN TONS ARMS REMOVED BS POLIFE STOP BELEIVE THIS DUE ARRESTATION OF A SEFTION FHEIF WHO GAVE ASRESSES ADIEU¹⁸⁰

Buckmaster, Vera Atkins or Morel could take this in at a glance, hardly noticing the transmission errors, and move at once to hold up *Clement* (Liewer)'s departure if it was in train; an inexperienced codist at home station might have had much more trouble with it. Signals provided two copies of each teleprint for the country section. In a large and busy section, such as F or RF, these two copies would probably first be looked at – simultaneously, but in different rooms – by a section signals expert and by a very junior staff officer. The rate of turnover among these juniors was high, as good ones got promoted, or turned into conducting officers, and bad ones were moved elsewhere. Their tasks were to indicate by pencil strokes how they thought any remaining scramble of letters broke up into words, to assemble maps or any other necessary papers, and to ensure that some one of their seniors decided on action if it was needed. The GSO II or section head who eventually got the message for action came to take for granted that all the people intervening between him and the originating agent had done their work properly, and simply read the main text that lay before him; ignoring the signals paraphernalia at the top of the teleprint, except for taking in the source and the date.

In the field, the difficulties of coding in clandestine conditions were such that any addition to them only made things more complicated than ever; in seeking to introduce a mistake or a run of mistakes on purpose, an operator might easily introduce several more by accident and thus render what he was trying to say unintelligible to London. Besides, the checks were useless as a safeguard in the most dangerous case, the case of an operator who changed sides, and went over altogether to the enemy; for of course he would betray his true checks as well as everything else. The Germans in any case soon did find out the double nature of the security check; and on many captured wireless operators they put such stern pressure to reveal what the true check was that only the most stoical and heroic could remain quite silent. Yet one recourse remained for the operator under moral or

physical torture; say what the true checks were, but mis-state how they were to be used.

This threw the responsibility for noticing that something was amiss back across the English Channel; and here the security check system ran into its worst difficulty of all – F section thought it unreliable. In some other country sections, especially in the small ones, elaborate pains were taken to check over messages; the slightest slip was cautiously examined, and an operator whose choice of words or frequency of error was at all eccentric became suspect at once: not so with F. The reasons for this were personal. Temperamentally, Buckmaster and many of his assistants were adventurous rather than methodical. They always inclined to resent suggestions bearing on their work that came from others. And the section signals officer for the last two years of operations in France, Georges Bégué, had worked a transmitter from the ZNO for six months with distinction without bothering about his security check at all.¹⁸¹ This was not a safe line to take, and trouble arose from it. F was not alone in doubting the efficacy of the checks; ‘Many members of the security directorate’, Boyle was told late in the war, ‘have never been happy about the bland way Country Sections and Signals dismissed the identity checks and certain mutilations.’¹⁸²

Yet another and rather more reliable method existed by which the identity of operators could be controlled; and they were encouraged to rely on it while under training. Before they left England, they each made a dummy transmission which was graphically recorded on a special machine that illustrated each agent’s personal style of sending; these styles or ‘fists’ vary as widely as handwritings do, and are as readily recognisable – both by ear, and by this recording system loosely known as ‘fingerprinting’. Unfortunately it turned out that the styles are also as readily imitable: this was the undoing of many of SOE’s agents in Holland and of several in France. Fourteen SOE transmitters in Holland were successfully worked back to England by half-a-dozen German operators;¹⁸³ the figures for France were not as large, but the imitations were almost as effective.¹⁸⁴ In one important case the signals staff reported a ‘hesitant’ transmission to the country section, which was in fact a German operator’s first attempt to imitate an English one. Otherwise the files show numerous occasions when home station spotted that a new operator, an agent’s local trainee, had taken over the set; but few when it was noticed at once that the set was in wrong hands.¹⁸⁵ Moreover Buckmaster himself had doubts about fingerprinting for an intelligible reason: ‘we knew that agents often had to send their messages in the most difficult conditions – it might be a central-heating plant in a loft or in the freezing cold of an outbuilding – and cramp or other afflictions could radically alter their methods of keying’. He added at once that ‘we at home had to be flexible and one cannot hide the fact that at times this flexibility led us to give the benefit of the doubt, at least for a while, to an operator who later turned out to be false. That was the fortune of war.’¹⁸⁶

In any case fingerprinting, like security checks, did not provide protection against the worst case, the agent who went over to the enemy heart and soul; for he would naturally work his own set back in his own style. No section working into France seems to have used operators ready to go that far.

Some arrangements for checking operators' reliability form an inevitable part of the running of any clandestine organisation; it is a fair criticism of SOE – which its security section made for itself, just after the war – that its arrangements were sometimes dangerously faulty. The signals directorate did include, from 1942, a section of its own devoted to signals security. But this body was staffed by signals and not by security officers, and it was out of touch with country sections at the day-to-day working levels. Its time proved to be so much taken up with technical points that it did not provide an adequate safeguard, for some circuits in France at least. An operational security section whose principal task would be to conduct a daily review of the whole of the incoming wireless traffic from the field was perceived, too late, as a main requirement.¹⁸⁷ But SOE introduced also a startling innovation: wireless communication to the field through the ordinary transmissions of the BBC.

In SOE's earliest days, Nelson had contemplated using broadcast Slav folk tunes as signals to warn agents in eastern Europe about forthcoming operations; there was a good precedent, the tune that Masaryk arranged for Czech troops in the Habsburg army to whistle in 1914 as they approached the Russian lines to desert.¹⁸⁸ But it was Georges Bégué who originally proposed¹⁸⁹ in the summer of 1941 what became the most conspicuous thing SOE ever did: the nightly broadcasting on the BBC's foreign programme, through some of the most powerful transmitters in the world, of scores of sentences which sounded either like family greetings or like Carrollian nonsense. 'Romeo embrasse Juliette', 'la chienne de Barbara aura trois chiots', just might mean what they purported to mean to somebody; but 'Esculape n'aime pas le mouton' or 'La voix du doryphore est lointaine' were clearly enough codes. Only the staff and agents concerned knew that such messages announced respectively the safe arrival of a PIMENTO courier in Switzerland from Toulouse, the impending arrival in Barcelona of three passengers on VIC's best line, a drop that night on a GLOVER ground near Chaumont, or a call for immediate telephone sabotage in RF's region R3, which ran from near Le Puy to Perpignan and the Spanish border. The Germans wasted a lot of time and emotional energy in trying to unravel this sort of undecipherable coding. This in itself was some gain to the allied effort. A greater gain was that agents in close touch with London could use BBC messages to demonstrate their own *bona fides* to people in the field who were doubtful about them, by getting London to transmit a message of the doubter's choice. And of course it was an enormous convenience to reception committees to get definite information that the RAF were going to attempt a drop on a particular field; in fine moonlit weather scores of messages announcing drops that night would go out each evening in the summer of 1944.

As a method of passing messages the BBC could not have been more public; but with one fearful exception its security was sound. The rate of traffic passing was kept fairly constant; dummy messages were passed if not enough real ones were available. However, there was one disaster: the Germans claim that some code 'action' messages calling sabotage groups out to work were known to them, and thus enabled them to discover on the evening of 5 June 1944 that a main allied landing was to take place overnight.¹⁹⁰

(E) IN THE FIELD

The basic system SOE ran on kept the whole central control of operations in England; this seemed to the authorities, as it always does seem to those responsible for secret services, an elementary rule of safety. The communists' simultaneous arrangements in France worked on a rigid set of similar rules: 'There should be no liaison whatever among the base units. There should be no liaison whatever among the cells. There should be no horizontal communications of any kind.'¹⁹¹ In the same way, neighbouring SOE circuits in France nominally knew nothing of each other, even if their working areas overlapped; they should have no good reason to intercommunicate at all, and if the need to pass a message from one to another did arise, the proper way to pass it was through home station. An exception needs to be made at once for DF; an escape line was clearly no use if escapers had no means of joining it, and little use if it could not shed excess traffic on to neighbour lines that were free. Our present concern is with the more directly operational circuits.

Though these were, in principle, forbidden to communicate with each other, their practice was much more haphazard. There was a strong though dangerous tendency for people who had taken to each other during training to try to see more of each other in the field. Agents, particularly those who were not French born, were often lonely; many of them had not had enough professional training to be able to endure their loneliness. They usually had security sense enough not to pick up a passing woman for company, but could not resist the temptation to relax in the presence of some other member of the brotherhood, with whom they did not need to continue to live their cover stories. More security sense would have warned them that such easygoing habits endangered their cover, which had to be borne in mind incessantly to be any use at all. One great circuit was ruined by this tendency of old school friends to hang together, which was fatal to most of its agents.¹⁹² Only foolish agents would make rendezvous with others in the field before ever they left England; but only strong-minded ones would have the resolution to ignore a former training companion they ran into by chance. Yvonne Cormeau, George Starr's wireless operator, met Francis Cammaerts in a

crowded train near Toulouse, a few days after she had reached France in August 1943; she tried to catch his eye, but he simply looked through her; she remembered to be discreet; and both of them lived to tell. In less public circumstances, agents might less easily resist the temptation to have a drink and a chat when they accidentally ran into old acquaintances in this way: through this natural failing several of the earliest agents sent to France came to be arrested, one being marked down as the visible friend of the other, who was already being watched without realising it.

But sometimes circuits did really need to get into touch with other circuits, to forward their own operations: how could they do it? If they had no wireless set, it might take months to pass a message through London. If they were fortunate, they had already been briefed with an address and a password that could be used, in specific conditions, to effect a junction. Otherwise, there was nothing to be done but send an agent to picket a town, a railway station, a restaurant, where there was some reason to believe he might meet an agent from the other circuit. If both had trained together, no introduction would be needed; though the least surly of agents might make a few inquiries to discover which side the one who had accosted him was working on. Accidental meetings in the street did occasionally enable agents to make important contacts in this way.¹⁹³

A good deal of ingenuity might have to be expended in finding a watertight system of establishing *bona fides*, on both sides, if previous contact between the principals had been more oblique. The four-day schemes at the end of the Beaulieu course ensured that agents had had a certain amount of training in this kind of intricate contact-making, which might well hinge on the unobtrusive dropping and picking up of some catch phrase inserted into a general conversation in a bar or a waiting-room. Once the two agents had recognised each other, it only remained to pass whatever message was involved.

This was where the basic training in message-writing on the Scottish courses was useful; like the Beaulieu training in unobtrusive message-carrying. The well-worn trick of inscribing the message on a thin, tight roll of paper, inserted into a cigarette with a needle, usually worked well; one agent said he had the pleasure of smoking a week's messages for London under the noses of his German captors.¹⁹⁴ Another habitually took the trouble to smoke a few puffs of the vital cigarette, stub it out, and then carry the stub in his hand while walking to a clandestine rendezvous, so that he could drop it in the gutter if surprised by a *rafle*.¹⁹⁵ There were innumerable ways in which agents could code their messages; here again Beaulieu training helped. Playfair provided an obvious though not a particularly safe system; oddly enough, there is only one recorded instance of its use for inter-circuit purposes, the romantic case of the imprisoned Defendini.¹⁹⁶

The amount of contact between neighbouring circuits naturally varied, both with tactical necessity and with the sense of discipline and security-mindedness of circuit commanders. In RF section there was much more of

it than in F; in DF section it was carefully limited and controlled, though the best of DF's organizers in France was not above poaching occasional agents from F; one of his best wireless operators was a local F trainee. The Poles of EU/P circulated as their orders laid down within their closed community.

Within circuits, it was seldom necessary to make arrangements that were at all elaborate for contact between members who did not know each other. 'Look out for a dark man with curly hair and tell him you come from Pierre' was the sort of plain instruction that would usually do; agents had little but common sense to guard them against German penetration in this perfectly simple way. Sometimes there was a circuit password; PROSPER members authenticated themselves to each other by inquiring 'Où peut-on trouver de l'essence à briquet?' and getting the reply 'Du carburant, vous voulez dire?'¹⁹⁷ With so large a circuit, this was probably convenient. But it had its dangers also, since the password's existence would make it more easy for an enemy counter-agent to get himself accepted as genuine if he could use it; with a circuit as insecure as PROSPER, it was only too likely that the Germans would get to know of it. But security deserves a chapter to itself.

Meanwhile, one point needs to be added; operational agents' opinion about it was almost unanimous. Though escape lines regularly used coded post or telephone messages, hardly any fighting circuits trusted either, however safe the codes. Telegrams were used even less, for the French bureaucracy insisted in wartime that telegram-senders produce evidence of identity; which clandestine agents were naturally reluctant to do. Beaulieu training had rightly insisted that postal services were likely to be carefully watched by enemy security authorities; and in a few cases careless use of them led agents straight to prison.¹⁹⁸ Of course this necessary distrust of the PTT did not stem from any lack of loyal helpers among the French post office staffs. On a number of occasions indeed these staffs went out of their way to help SOE's teams in preparing the sabotage of telephone and telegraph networks; and sometimes in France, as in Holland, an entire telephone network was available to resistance.¹⁹⁹

V

Security in France

‘The nature of the work undertaken by SOE made penetration inevitable and considering the number of factors in their favour the Germans cannot be said to have achieved their objects.’¹

SOE agents in France needed to keep themselves safe from several overlapping police jurisdictions, some German and some French. We live in a comparatively free society, removed by some distance in time and space from the immediate urgencies of war, hunger, occupation and repression. It is easy for us to forget what life was actually like for SOE’s agents in occupied territory, or even for the ordinary inhabitants of France. Every step in their everyday existence might be reported, considered, commented on by one secret police force or another. Unless wealthy, they were often short and sometimes very short of food; if they were men of anywhere near military age, they were in constant danger of being sent off east in a forced labour convoy. Moreover they were contending with enemies of exceptional savagery.

The nazis secured their hold on power in Germany by a carefully thought-out series of manoeuvres based on three premises: that maximum power is the most desirable of objects, that Adolf Hitler’s orders for securing it are always to be obeyed, and that absolutely no regard is to be paid to any other code or precept. Hitler had done the thinking out, and had his gangs trained already to obey him. On this foundation of limitless bad faith the ‘new order’ arose. The German security services’ performance was erratic, and did not always bear out the sedulously fostered myths that they knew everything and would stick at nothing. Once in their hands, many millions of people died in agony, and no one could feel safe; least of all an agent of a hostile power. Yet their senior staffs were obsessed by service intrigues, and their junior staffs were often as incompetent as they were cruel. Several SOE agents who were over-enthusiastic, or under-trained, or both, for their work in France were able to elude arrest and returned to recount their adventures; more thanks to the Germans’ inefficiency than to their own discretion. The nature of the nazi state machine ensured that many German counter-espionage

agents were more interested in promoting the status of their own organization as compared with its rivals at home than in actually coping with the activities of allied agents in the field. The term 'counter-espionage' is here used loosely to cover all security work; SOE's agents were not *espions* of the traditional kind. Counter-measures against them, or any other allied agents, were not organized to suit their role, but to fit in with the exigencies of the struggle for power at Hitler's court. As the complex subject of this struggle for power only touches SOE's affairs at a tangent we can put it on one side at once, only pausing to notice the basic divisions in the security forces SOE had to grapple with.

In France, they were usually run from Paris, whence the *Oberbefehlshaber West* – commander-in-chief, western front – ran his administrative services; both before and after the German occupation of Vichy territory. There were two minor exceptions to this: the Nord and Pas-de-Calais departments were put under the security authorities in Brussels instead; and half a dozen departments on the Italian border were supposed to be supervised from November 1942 to September 1943 by the Italians instead of the Germans, though in fact the Germans were active there as well.

There were two distinct overlapping German counter-espionage organizations, one military and one party; they were at daggers drawn with each other for most of the war, and in the end the party organization swallowed the military one up. 'It is difficult with these evil folk to know when they are in league, and when they are cheating one another', the good wizard says of the bad ones in Tolkien's epic;² and the remark can be applied to the German security services that perhaps inspired it. Interdepartmental warfare is endemic in bureaucracies. In London in the early forties it was not unknown; but its proliferations, harmful as they occasionally were, were of trifling import compared to the battles that raged on this front in Berlin. In these pointless though not always indecisive engagements the armed forces and the SS were two of the main contenders. Each had a security service – the Abwehr under Admiral Canaris,³ and Himmler's SS *Sicherheitsdienst* under his personal control from the *Reichssicherheitshauptamt* (RSHA; literally, 'imperial security headquarters'). Either might be described from the worm's eye or occupied countries' view as 'the Gestapo'; and the chapters below follow popular rather than pedantic usage. But in fact they were distinct, and up to the end of 1943 a captured agent's fate might well hinge on which of them kept charge of him. All through the first four years of the war Canaris and Himmler were at odds with each other, each striving for exclusive control of security and so of the state. The run of German defeats in the field in the winter of 1943–44 finally enabled Himmler to discredit Canaris, who was dismissed in February; later that spring Canaris's entire staff was gradually absorbed under the RSHA, and the Abwehr formally expired on 1 June. The admiral's equivocal position on the fringe of the plot against Hitler that exploded on 20 July cost him his liberty and eventually his life; he was sent

to Flossenbürg, where he was executed in April 1945, surviving some of F section's best agents for about ten days.

In France his Abwehr had had two main branches, both independent of the uniformed army *Feldgendarmarie* who were as conspicuous, with their brass breastplates, as their British equivalents in red caps. One Abwehr branch, the *Geheime Feldpolizei* (GFP) or secret field police, was indeed as much under army as under Abwehr control; its principal task was to arrest suspects. These were pointed out to it by the other branch, especially its section III F which handled the repression of allied agents. III F in France contained some competent intelligence officers; but like the rest of the Abwehr it suffered not only from rivalry with the SS, but from overlapping and competing jurisdictions within its own sphere. Its main Paris headquarters lay in the Hotel Lutetia, on the Boulevard Raspail on the left bank; it had important outstations at Le Havre, Angers, Nantes, Bordeaux, Dijon, and Lyons. There was also an outstation at Lille which depended on Brussels. Only one Abwehr personality who had much to do with SOE's agents needs introduction now: Hugo Bleicher. The oddest of the many odd things about Bleicher is his rank: he never rose above sergeant – perhaps because he was too officious, too earnest, too zealous for his superior officers to contemplate treating him as anything like an equal.⁴ In any case, Bleicher's importance in the affairs of SOE has been considerably exaggerated, not least by himself; as will become clear.

The exact nature of the Nazi party organization that was fighting SOE was complicated enough to baffle a theologian. One thing was clear about it; its chief, Heinrich Himmler. But Himmler as well as being head of the whole of the SS was Hitler's minister of the interior; as such he controlled both the *Ordnungspolizei* (Orpo) or civil police which kept order and the *Sicherheitspolizei* (Sipo), the security police which also operated wherever the Germans were in control. The Sipo was divided in turn into the *Kriminalpolizei* (Kripo) and the *geheime Staatspolizei* (Gestapo), extended by the Nazis from the secret political police of Prussia. The Gestapo, under Section IV of the RSHA, was responsible for arresting agents. It overlapped with the *Sicherheitsdienst* (SD) under Section III, the party security service. Between them these two sections came to run the private and public lives of several scores of millions of people, and the principal gain from the victory of 1945 is that they no longer do so.

Arguments about the distinctions and resemblances between the Gestapo and the SD are as valueless as the old disputes about how many angels can dance on the point of a pin. The practical point is that they worked, from an allied agent's point of view, as one.⁵ Their officers and NCOs were all members of the SS, originally Hitler's elite party bodyguard, which came over the dozen years Hitler spent in power to incorporate the scum that rose to the top of the cauldron of national socialism. The two bodies were indicted jointly at the great Nuremberg trial. All the administrative and

executive officers of them both who staffed Amt IV, the counter-espionage section, of the RSHA, as well as all such officers who served outside Germany during the war (unless they served only in the GFP), were collectively found guilty of war crimes and of crimes against humanity.⁶ The same charges were found to be proved against the officers of the SS,⁷ largely on the strength of its activities in the concentration camps. The very worst of its members were to be found in those unspeakable hutments where many scores of SOE's agents, two hundred thousand French deportees, and many million Jews were killed in circumstances of barbarity that would have been inconceivable before 1933 and must still send a shudder down the spine of any sensitive man or woman.⁸ The SS staff in France were comparatively, but only comparatively, human. Many of them were inexpert and brutal interrogators, and Jean Moulin, the most important man SOE and the BCRA sent to France they ever captured, was interrogated by them so brutally and so stupidly that he died in their hands without saying a word (not that he would have said anything had he lived).

Under the SD there also worked a certain number of civilians of various nationalities, including a lot of French collaborators who thought they could serve themselves best by staying on the winning side and did not realize which the winning side was going to be. Rémy, in *Une Affaire de Trahison*, sketches the iniquitous Georges Delfanne, better known as *Masuy*, the inventor of a favourite torture: plunging the naked victim into a bath of ice cold water, holding him or her down almost to drowning point, and then offering to stop in return for the answers to questions. A fair number – by no means all – of SOE's captured agents had to put up with brutal treatment, though seldom as bad as this. On the whole, Frenchmen in German hands were more likely to be knocked about than were Englishmen – this was an accident of the nazi racial myth; but there is nothing in the theory that separate Gestapo sub-sections handled RF and F agents, and that RF agents were tortured as a matter of routine while F agents were never tortured. At the main SD counter-espionage headquarters, 82–86 Avenue Foch, just west of the Arc de Triomphe, separate houses were used to interrogate agents from the two sections, but torture might be applied in any of them:⁹ as it might be applied in the Gestapo headquarters at 11 rue de Saussaies, at the back of the French ministry of the interior.

There were SD offices not only in Paris but in all the large cities of France.¹⁰ Among personalities in the SD three or four are worth mentioning here: Knochen, who was the *Befehlshaber der Sicherheitspolizei* (BdS, head of the Sipö) in Paris for most of the war;¹¹ Boemelburg, the head of his counter-espionage section IV, a tall elderly heavy-drinking homosexual; his subordinate, the curly-headed Josef Kieffer, the only man connected with the repression of SOE in France who had had much relevant pre-war experience – he had been a police inspector at Karlsruhe; and Josef Goetz, a former teacher who handled IVF, Kieffer's wireless sub-section, with a considerable degree

of skill.¹² As far as SOE's agents in France were concerned, the absorption of the Abwehr into the Gestapo was only a formal change. The kind of security officer they were struggling against was usually, as before, a rather wayward nazi devotee who was more likely to have had experience in the criminal underworld than to have had a professional training in the tasks of counter-espionage. This was not the sort of man a skilled and resolute agent would have much trouble in outwitting; though others, Goetz included, were brighter.

Parallel with these German organizations there existed of course the routine machinery of the French civilian police, to which the Vichy regime added a substantial number of special inquisitorial bodies – so many that by the end of 1941 there were said to be fifteen different French police forces. There is no need for this complex skein to be disentangled here. The point worth noting about the French police is this: that the senior officers' loyalty was usually to the ministry of the interior from which they received their orders; though the bulk of the lower police ranks inclined rather to favour than to disapprove resisters of all kinds. As with the mass of the French civilian population, the proportion who were prepared to support anti-German activities rose as the war went on and the chances of beating Germany improved. Some of SOE's earliest efforts in France depended on clandestine French police cooperation; in some cases the police officers concerned had to be brought out by air. Two inspectors cooperated so warmly that the F circuits in their neighbourhoods put them, when their own stations got too hot to hold them, onto lines over the Pyrenees; they later went back to lead circuits of their own.¹³

In dozens of cases ordinary policemen, particularly in the country, carefully looked the other way while SOE's business was done, or even advised agents in a friendly way to get themselves better forged identity cards or to carry their pistols less conspicuously. Some of the French police services were a good deal less cooperative than others: the concentration camp guards, though far less sadistic than the SS, were despicable enough, and such bodies as the GMR varied a good deal in their attitude according to the personal loyalties of their local commanders. On the whole SOE had much less trouble from the French police after the occupation of the Vichy zone by the Germans in November 1942; and while no agent could ever rely on the cooperation of a chance-met French policeman, many secured it.

One French security force deserves especial mention, for it was especially detested. This was Darnand's *milice*. It originated as a semi-chivalrous body of gentlemen anxious to restore the damaged military honour of France;¹⁴ it came to draw its recruits from much less exalted circles – 'Scum of the jails, brutalised of the most brutal, cream of the offal', as Millar called them,¹⁵ the same sort of would-be gangsters as the dyspeptic young thugs Mussolini and Hitler had built their movements on. Miliciens were Frenchmen who lived and worked in their home towns and villages, and used their local

knowledge expertly; this was what made them so dangerous to agents whose paths they might cross. For while the ordinary police might be friendly or at least neutral, and the Germans were strangers and might be bluffed, the miliciens were sharp, suspicious characters wholeheartedly devoted to the bad cause and only too fully informed. They were often sadists as well, who enjoyed making nuisances of themselves by tiresome inquiries, were fond of threatening language, and enjoyed carrying out their threats. They might be found at work in any part of France, and their presence always served to put agents on their guard – if it was realised in time.

The British have always held sound security to be indispensable for clandestine work of any kind. The French undoubtedly suffered from plain ignorance in this important field; as one of them put it years later, ‘The French have no experience of clandestine life; they do not even know how to be silent or how to hide.’¹⁶ The weight of evidence made available in France during the war told heavily in the British sense; the longest lasting of the British-run circuits were almost always the most secure ones, and some of the French-run organizations – those most closely guarded by the communists and a few of the French intelligence circuits – were also long-lived and successful. But total security means total inactivity, which is useless: ‘Caution axiomatic, but over-caution results in nothing done.’¹⁷ Every agent had to combine discretion and daring in a formula he had to work out for himself, in the light of his training and personality, and of the actual circumstances facing him in the field. ‘Security is really only a question of care and common sense’, said one of the section histories, ‘and if agents are well-trained security will become second-nature to them. The danger lies, not in themselves, but in the people they have to contact in the field.’¹⁸ As Cowburn put it in an exasperated moment, ‘Security in France was nil, and 95 per cent of the people arrested, were caught simply because their friends had been incapable of keeping their mouths shut.’¹⁹

Here lay the key to security: picking colleagues trustworthy enough not to gossip. Anyone who has had secrets to handle knows how strong the temptation is to impart them to somebody; sophisticated but undisciplined people who had to know secrets of SOEs in France were often careless in their choice of people to confide in, and so word got round too fast and too far. The only guard against this was constant caution: never make a rash approach, never enrol chatterers, never tell anybody anything bearing on secret work unless the telling will directly help the work forward. The extent to which an agent could follow these precepts varied with his role; people preparing or conducting sabotage or guerilla had to take more risks, and expose themselves more often, than escape line staffs or traditional clandestine intelligence agents. DF’s agents for instance could afford the luxury of never taking the metro in Paris;²⁰ F’s and RF’s were usually in too much of a hurry to spare the time to walk, and had to risk the controls at the main metro interchange stations. This might lead to awkward encounters, involving at

best inconveniently conspicuous escapes and at worst arrest or even death on the spot: French and German police alike were armed, and quick to shoot if crossed.

How each agent worked out his private formula for security was, of course, an individual matter; it would depend on the nature and completeness of his cover, and on his orders, which depended in turn on the tactical and strategic objects of his mission; naturally it would also depend on his character. Happy-go-lucky people did not bother much about all this; a few of them survived. Others, more suspicious-minded, thought of little else; most of these extra-cautious ones lived to tell, and a few of the most energetic of them could put beside a record of complete discretion a distinguished subversive record. Yet not even the most meticulous and devoted of agents could always save themselves from howlers, in which by a moment's carelessness they might endanger their own and their companions' lives. Maurice Southgate (*Hector*), seasoned by many long months in command of a large circuit in the Limousin, once forgot when calling at his assistant wireless operator's to look out for the prearranged danger signal; and that once the Gestapo were waiting for him inside.²¹ France Antelme (*Renaud*), steeped in his cover story as M. Antoine Ratier, had not been a week in France when he recalled as he was shown to his room that he had signed a reception slip at a Poitiers hotel 'France Antelme'; he was able to retrieve the incriminating piece of paper in time, murmuring he had put a wrong address on it. Even Cowburn, briefing his team for his model attack on the Troyes locomotive roundhouse, used a school classroom blackboard for the purpose, and forgot when he had done to wipe it clean; it carried 'the unmistakable outline of the target and the plan of the attack'. Luckily the schoolmaster's wife saw and cleaned it in time; her husband was one of the saboteurs, and she had no wish to put him in more danger.²²

These illustrations bring out the most important element in agents' safety: luck. Only luck kept Southgate's principal wireless operator and his courier from hurrying with him to call on the second wireless operator on that dangerous May Day 1944. The courier assured the operator that he looked worn out, and must have the afternoon off work; they went for a picnic and a bathe, and survived to reconstruct two highly successful circuits, WRESTLER and SHIPWRIGHT, from the wreck of Southgate's STATIONER. Dozens of other instances will be found below. Here as in other ways SOE's operations only conformed to the usual rules of war and of human behaviour, as they have long been known and commented on.

The importance of luck in clandestine war can be taken for granted. But what happened to the agent whose luck ran out? If arrested, he did his best to tell his cover story; but seldom with success. Arrest usually meant discovery; discovery usually meant torture, followed by deportation; deportation in turn usually meant death. There were exceptions: a very few absolutely first-class operators stuck to their cover stories firmly and lucidly, and outwitted

their interrogators. Zembsch-Schreve (*Pierre*), the organizer of DF's PIERRE-JACQUES line, vanished in April 1944 in Paris; his friends got to his flat before the Germans did, and removed the only compromising thing in it – a list of all the circuit's contact addresses and telephone numbers, in an easily broken Playfair code; at first they thought he had been picked up in a street *raffle* collecting men for forced labour, and when they discovered no one of his cover name had been arrested, they assumed he had disappeared for private reasons, with a girl he was fond of. In fact his security precautions had been so elaborate that he concealed even from his own second-in-command another cover name he was using; he had been caught passing a wireless transmitter to an agent of another section, in accordance with 'decipher yourself' orders from London in his personal code, but managed to convince the Germans that he knew nothing of the contents of a case he had handed over, at an unknown third party's request, to a business acquaintance. The Germans took him away, on suspicion, to Dora, though they could pin nothing on him; and even from Dora he managed, in the closing weeks of the war, to escape.²³ Again, F section's Tony Brooks (*Alphonse*) was picked up in what he took for a routine street control in Lyons on the last Saturday of July 1944; unarmed, and carrying nothing compromising but 72,000 francs of SOE's money, he remained as unruffled as he could while successive screenings reduced to 250, to two dozen, and to five the number of men the Germans were holding – all about his own age and size and all wearing toothbrush moustaches like his own. He spent the week-end in solitary confinement, with nothing to wear but his underclothes and nothing to eat at all; he was then – still unfed – put through a whole day's cross-questioning about his cover life history. By good fortune the enemy probed his cover most deeply where it was watertight and left it alone where it was leaky; accepted his explanation that the money was to buy a suit on the black market; returned every centime of it to him next morning with an apology, and let him go.²⁴

Good luck in fact might supplement good security. What was always dangerous and often fatal was to rely on good luck to outweigh bad security; and an agent who failed to take incessant trouble to keep his cover intact, his relations with his subordinates tenuous, and his sub-agents inconspicuous and silent, was rendering no good service to the allied cause. A perfectionist kept even his private address and his usual cover identity to himself, so that if a sub-agent was caught no harm to himself and little to the circuit was likely to follow; not many agents were so careful.

Almost insuperable difficulties were of course confronted by agents who could not speak even reasonable French, and had no cover which could explain their lack of it. Hugh Dormer, whose own French was accurate, but slow and spoken with a marked English accent, once found himself travelling away from a coup de main by train with a sergeant who could speak no French at all:

I kept my eyes always on the corridor to make certain B was alright and no one was speaking to him ... I had arranged ... to say that he had had a bad accident and a paralytic shock and was struck dumb ... Suddenly, while the train was still running, a German Gestapo official in uniform entered the carriage, turned on the lights and demanded to see all our papers. He wore glasses and had a square torch clipped to his tunic, and imparted a great atmosphere of fear and malevolence. I showed him my card, and, after one look at me, he handed it back. But to my horror, when he reached B in the corridor, he examined the back of his card closely for several seconds (it was of course forged) and then I heard him ask B something in French. As he could not speak a single word, my heart nearly stopped beating, and I was on the point of getting up out of my seat and intervening, as I had promised. Meanwhile B, like the farmer's son, he was, just shrugged his shoulders and continued to stare at the floor. The German gave him a contemptuous glance, as though he could not waste time talking to such an illiterate oaf when he still had the whole train to examine, and passed on down the corridor.²⁵

Dormer and Birch were fortunate to get away. But many scores of agents did not; and they were not always treated at once with the brutality that killed Jean Moulin and almost killed Yeo-Thomas. Some of the interrogators who dealt with captured agents in Paris were intelligent and sensitive men who had mastered the basic rules of interrogation: never admit to ignorance, and frighten your victim but not too much. They made a little information which had come into their hands about SOE go a long way, and with its help secured some damaging admissions. What motives induced so many captive agents to unburden themselves as fully as they did under interrogation? The shock of arrest seems in many cases to have induced a sort of relief; having treasured for months the secret of their clandestine activity, some people seemed to have been unable to resist the comfort of admitting and discussing it. This was, of course, a cumulative process, for the more agents talked, the more material the Germans had available to exploit this natural if unfortunate tendency and make agents captured later talk as well. Another element besides relief might encourage some captured agents to talk; this was conceit. Some people could not bear to have it suggested to them that their position had been at all a subordinate one; and in order to explain to their captors how important they had been, they revealed a great deal that would have been better left unsaid.

Nevertheless, a really good agent continued to fight while unarmed and in enemy hands as fiercely as he had fought while he was still at large. Harry Peulevé, for example, was told by the Avenue Foch staff. "Of course you realise we have in Orchard Court an agent working for us, and we know the real identity of all your agents". It seemed to [me] to be a "try-out", for an enemy agent working in Orchard Court would not probably know the real identity of all the agents sent out by SOE.²⁶ Peulevé continued to provide

the Germans with no information at all, and successfully maintained that he was only a wireless operator who had lived in strict isolation, and could not tell them anything of importance; they never discovered he had been an organizer with over 3,000 armed men under his command.

The allegation that there was a traitor somewhere in SOE's headquarters was often used by interrogating Germans, and many credulous agents were unnerved by it at once. No twelve apostles, it has been said, without an Iscariot: this seems a general rule of behaviour. Trotsky, with Lenin the main architect of the bolshevik revolution, has long been depicted as a traitor by bolsheviks disappointed that the revolution did not at once bring a new heaven and a new earth. The principal nazi leaders, defeated and put on trial at Nuremberg, credited treachery somewhere in their own high places as the only possible explanation of their defeat. On a much lower level a captured agent in the hands of the SD might be ready to believe anything of his superiors; hardly anybody remembered the obvious counter to such claims to knowledge, 'if you know so much already, why ask me anything?' In fact no evidence of a German connexion in Baker Street has ever come to light, though an earnest French security officer tried to manufacture some in February 1945; and a clinching argument against any such thing came from two French agents of the SD, speaking in the shadow of the guillotine at about the same time. Asked if they had heard of a leakage direct from London, 'they were both emphatic that, not only [had] they never heard such a thing, but [they] had frequently heard Goetz and [his assistant] Placke say: "What a pity we haven't got somebody in the London Headquarters. We must try and get somebody over there."'²⁷

Part II
Narrative

VI

Politics and the Great Game

There was a paradox at the centre of SOE's existence. Winston Churchill, the body's first weighty promoter, was a duke's grandson, best known till that time as a resolute opponent of what he once called 'the foul baboonery of bolshevism'. Though his government was a coalition, its main political base lay in a conservative majority in the commons more than twice as large as any that party has since enjoyed. Yet SOE's subversive purpose was revolutionary: it was dedicated to the forcible overthrow of nazi dominion in Germany, and of the puppet rulers who depended on the nazis for power, Pétain above all. SOE's task in France was to provoke, under conservative sponsorship, another French revolution.

In the German-occupied countries, SOE's revolutionary purpose necessarily varied with the previous type of government. In the democratic monarchies the object was simply to re-establish them. In Czechoslovakia the object was to reinstate Benes, and reinvigorate the republic he and Seton-Watson had founded under the great Masaryk in 1918. Elsewhere, where prewar regimes had been farther to the right, political objects were correspondingly uncertain. In Poland for instance, for whose sake Chamberlain's Britain had originally gone to war, the original aim was presumably to restore the colonels' republic divided between Germany and Russia at the fourth partition; or at least that aspect of it represented by the 'London Poles'. This led eventually to a bitter and tangled dispute with the USSR in which the 'Lublin Poles' gained the day and British diplomacy received a decisive check. In Italy policy varied with the waxing and waning of Mussolini; SOE had a voice, though not a loud one, in his fall. In Greece and in Yugoslavia SOE sought to back any anti-German bodies of resisters, and thus accidentally came to pursue opposite policies simultaneously; supporting the exiled king and all that he stood for in one case, and Tito's partisans with their communist aims in the other. Now

France was and had been for centuries a country of much sophistication in politics, as in many other fields; and the French case was in a class by itself. For while Pétain turned out to provide an equivalent to the Quisling regime in Norway, the question of who the French equivalent of King Haakon was remained open – legally, at least – till after France had been freed, and was indeed the subject of a first-class political dispute between Churchill and Roosevelt.

Who is to govern France? has been a question of secular interest to Great Britain, quite as important as the question Who is to govern Germany? has been to France. Hence the interest and the importance attached to French problems by British governing authorities all through the war – a war which centred on the problem of who was to control French territory. In that apocalyptic June of 1940 Churchill's newly formed War Cabinet offered the third French republic union: a complete fusion of the two states into one. The offer, conceived in a moment of impassioned generosity, had never been worked out in any detail. It was swiftly drawn up in London by Vansittart and a few other people who happened to be on the spot,¹ and telephoned across to Reynaud the French prime minister on 16 June by one of them, a forty-nine-year-old French brigadier-general who had recently fought with distinction, his under-secretary for war: Charles de Gaulle.² The offer elated Reynaud for a moment, and de Gaulle flew to Bordeaux at once with the text; but the French prime minister, sickened by the defeatism in his political and personal entourages, resigned that night. The general was smuggled out of the country next morning in Sir Edward Spears's aircraft; bearing with him, as Churchill remarked, 'the honour of France'.³

On the night of 16/17 June the aged Marshal Pétain, Paul Reynaud's successor, put out feelers for an armistice. On the 18th, de Gaulle made his celebrated broadcast calling on those Frenchmen who agreed with him to continue the fight for freedom and proclaimed on a poster that France had lost a battle but not a war; the British Cabinet only reluctantly approved this step, fearing it would too much antagonise Pétain,⁴ whom little in fact could antagonise further. On the 22nd an armistice between France and Germany was signed. Next evening de Gaulle announced, in another broadcast from London, that he was setting up a French National Committee which would account for its actions to whatever legal representatives of the French people could be found after the Germans had been driven out of France; and on the 28th the British government recognised him as 'the leader of all Free Frenchmen, wherever they may be, who rally to him in support of the Allied cause':⁵ not, it will be noted, as the head of any sort of government. Churchill had minuted to Halifax on 24 June that 'We shall, of course, recognise the de Gaulle Committee as the the responsible Constitutional representative of France';⁶ the Foreign Office succeeded in suspending action on this minute for over four years. On 3 July the British attacked the French fleet in the harbour of Mers-el-Kebir; on 5 July Pétain's government

broke off diplomatic relations with Great Britain; and on 10 July the third French republic that had originated amid the disasters of 1870 was wound up.

Thus two authorities were established to compete for the loyalty of Frenchmen. One, under an eighty-five-year-old Marshal of France, 'an excessively garrulous and vain old man',⁷ settled down at the inland spa of Vichy under the name of the *Etat Français* – the French State: no truck with republicanism, nor with royalism either – and proceeded to multiply decrees and regulations, administer rationing systems, and receive accredited representatives of friendly powers. The town of Vichy had plenty of accommodation for ministries in its dreary hotels, but no other trappings of a capital. The other authority, under the most junior general in the French army, had no more legal authority than the Vichy regime had; indeed it had even less, for Pétain had at least had his powers entrusted to him, however unconstitutionally, by the rump of a constitutional parliament, while de Gaulle had appointed himself. What else could an honourable man have done, who wanted to keep the battle going? From the earliest days, he offered to serve under any other French general who would take the lead: as early as 20 June he said to Cadogan 'that if General Weygand were shewn to be organizing resistance in French overseas territory, he would at once offer his own services to him'.⁸ None of them would. So he set up his much more sketchy offices in such places as he could find in Westminster and Kensington; his headquarters settled at 4 Carlton Gardens, on the site of a town house of Lord Palmerston's and opposite one of Mr Gladstone's. The Englishness of his surroundings, at the office or at his private houses in Hampstead or Buckinghamshire, left him as it left his staff, quite unaffected; French visitors to Carlton Gardens at once felt themselves in France.⁹

Each of these two military regimes needs to be examined in a little more detail to illustrate SOE's role in the wartime politics of France.

In spite of his great age, Pétain was more than an imposing figurehead at Vichy. He formed his government under the impression that 'The country has been rotted by politics. The people can no longer discern the face of France through the veil politicians have thrown over it.'¹⁰ He employed a few politicians, headed by 'that sinister and uneasy spirit ... able, ruthless and wholly unscrupulous',¹¹ the much detested Pierre Laval, but he disapproved of politics as an occupation; his ministers governed by decree, and normal party and electoral life came to a standstill. Ministers received firm support from most of the great banking and business houses, the *deux cent familles* who were alleged by the left before the war to be the real rulers of France, the only people who counted. Most of the rest of the 'party of order', the informal grouping of many parties which is the secular representative of French conservatism,¹² supported Vichy too: princes of the church, eminent intellectuals, leading members of the bar, most people of consequence were for it; above all, the civil servants toed whatever line was drawn before their feet.

The French cherish a great tradition of administrative continuity. It reaches back from the republic of today through the intervening regimes to Gambetta's newly made republic of the seventies; back through the second empire that Gambetta overthrew to the first; back even behind Napoleon to Turgot and Colbert, behind Turgot and Colbert to Mazarin and Richelieu. The tradition did not fail them in defeat. The army might be reduced by the armistice to 100,000 men to suit a whim of Hitler's, because the treaty of Versailles had imposed just that limitation on the German army that had rescued him from the slums of Vienna and Munich and made something of him; the national territory might be truncated; foreign flags and foreign sentries might sprout in the streets of the capital; worse, the ministries themselves might have to transfer their most valuable accumulated files to the new seat of government; but government must go on. *Fiches* and *fichiers* must continue to be filled in, *ruat coelum*, though the heavens fall. Pétain was there: he had the external apparatus of power. Many political theorists, from Hobbes through Humpty Dumpty to Lenin, agree that someone must be master: as Pétain had the trappings of mastery, the bulk of the French population, led by their bureaucrats, at first agreed to obey him.

Given this background, clearly one of the most effective means of undermining confidence in Vichy would have been the debasing of its currency by a flood of false notes; but this was a type of operation that a strict Treasury ruling forbade SOE to attempt in Europe.¹³ More directly political and military methods had to be tried, and they needed a focus. Now two things were necessary before a free French government in exile could be formed, to be that focus: a substantial body of agreement among the occupied French that both the nazi occupiers and the regime of Vichy were detestable and had got to go; and an adequate body of agreement among the available French men of war and politics about who should turn them out and how. SOE had much to do with all this. We can set aside EU/P's role, which was primarily Polish, and DF's which was technical; AMF and the JEDBURGHs exerted their might fairly late on; but the duties of both F and RF sections were cardinal. When in the autumn of 1944 de Gaulle denounced F's organizers as British mercenaries, he misconceived their role: they had become, in the end, as anxious as anyone else to put him in power, and but for RF his own organizers could never have found their way into the field at all. Yet it was not till well on in the war that he became generally accepted as the one man who could head a successful resistance movement; even then, a substantial part of the support that was offered him – especially from the far left – was offered with the barely concealed intention of deserting him the moment he had served his purpose and got the Germans out of France. Meanwhile, it was an allied necessity to co-operate with all the anti-German French, not only with those who would fall in behind the oriflamme of Charles of Lorraine: this was what F section was for.

What was there in fact in France in the way of political resistance? At first, as serious French historians admit, there was very little indeed,¹⁴ but plenty came with time. Time brought many controversies. Was it best to accept the fact of German domination and collaborate, or to follow the aged marshal in an attempt at an independent policy, or to resist? If to resist, with what object – to restore the third republic, or one of the monarchies; or to build a new kind of France, and if so with marxist or Christian or agnostic inspiration? And under American or British or Russian or purely French sponsorship? And under which French military leader? Differences about which side to take in these numerous disputes split French society asunder, from top to bottom;¹⁵ not since the Dreyfus affair at the turn of the century had such cleavages opened between teachers and students, priests and congregations, parents and children, brothers and sisters, husbands and wives.¹⁶

Although the Vichy regime had much support from the old French right, so did the resistance. Many royalists were at first too much tempted by the prospect of a restoration engineered under Pétainist guidance to help it much, but the aristocracy, royalist and Bonapartist alike, had other views. It was only to be expected that families conscious of great feudal or military origins would be sensitive about being governed by foreigners, and anxious to do the honourable thing. Let one example stand alone for many: a prince of the house of Murat, descendant of the greatest of cavalry generals by Napoleon's sister Caroline, was killed in action in 1944 alongside a JEDBURGH team near his home in the Dordogne.¹⁷ The regular army also continued to smart under the disgrace of defeat in 1940 and under the humiliations imposed by the armistice. But nothing serious came of 'the armistice army' as a combatant resistance force until the very end. This was partly due to reverence for the Marshal personally; partly because a good deal of army and air force activity went into intelligence work, which inhibited *service action*; partly because some lines of contact – some of F section's particularly – were bad; and de Gaulle as a very junior general and a formal rebel, condemned to death in his absence by the Vichy regime, could not easily command support in the starchiest circles of the French regular officer class. The navy, smarting from Mers-el-Kebir, was lashed by Darlan to the mast of Pétain's ship of state.

On the left, the forces of 'the party of movement', the other great branch of the French political tree, were even more discredited by the fall of the third republic than the forces of 'the party of order'. Though the defeated army was officered by the right, it had got its orders from the left, on which it blamed its lack of armament and even its lack of will. The whole sorry story of the appeasement negotiations of 1936–39 looked sorrier still with every month that passed; all through that time governments of the left had been in power in France, and they could not help being discredited by it. The radical party which had been the mainstay of almost every government of the third republic¹⁸ foundered with it. The socialist party split, a few of

its deputies voting full powers for Pétain, many of the rest leaving France for North Africa in the mistaken impression that their colleagues would follow. The trade union movement was still in disarray after the strikes which had accompanied the Popular Front of 1936 and various communist attempts to penetrate non-communist unions. The French communist party, proscribed by Daladier's government at the beginning of the war, was quite as discredited as the radicals though for different reasons. The communists had to live down, before they could play any useful part in resistance, both memories of the Ribbentrop-Molotov pact that had precipitated the war and the still more recent recollection of their advocacy of collaboration with the nazis in the early months of the German occupation. A clandestine number of *Humanité* dismissed de Gaulle as a hireling of the City of London, unworthy of the attention, let alone the support, of patriotic and intelligent Frenchmen.¹⁹ Communist collaboration with the Germans went indeed so far that arrangements had been completed with the occupation authorities for the legal reappearance of *Humanité* when two party trustees carrying the text to the printer were intercepted by Pétain's police and imprisoned for breaking the restrictions imposed by Daladier: a neat example at once of marxist opportunism and of French administrative continuity.²⁰ By the spring of 1941 even the most dyed-in-the-wool French communists were getting restive at this collaborationist policy, and on 22 June 1941 in France, as in other western European countries, the party's attitude to the war turned a complete and immediate somersault. Thereafter the French communists began seriously to organize the work of resistance for which in any case the core of their party was well suited: it had had plenty of training and some experience in clandestinity already.

The other influential body in France which had a tradition of resistance to oppression behind it – though a distant one – was the Roman Catholic church. Although the Vichy regime was supported by the bulk of the popish hierarchy, and had a strongly popish flavour, a large majority of the country priests of France put their duty as compassionate human beings before their duty of obedience to their bishops. Allied aircrew shot down over France, or allied commandos left behind on raids, were recommended to apply for advice on how to escape to any village priest; and there can hardly have been an instance when this trust was misplaced. The political forces so far reviewed continued to pull in divergent directions; yet it is a mark of the kind of national unity, transcending party and prejudice, which developed in France during the war that, next to the priest, the most reliable man to call on for help in a country village was either the station porter or the schoolmaster. De Gaulle and SOE had this task at least in common: to encourage this unity by canalising the energies of as many resisters as could be against the nazis instead of each other.

The nazis in any case were their own worst enemies, and the real though unintended founders of all French resistance. Their propaganda was even

more inept than Vichy's. Vichy tried for a time to spread the idea of *France seule*, that is, the idea that France could get on perfectly well by herself without any truck with the British or the Americans or the Italians or the Russians, and with as little truck with the Germans as the iron fact of defeat allowed. Goebbels put out a few leaflets and newspaper articles encouraging the French to believe that they had a useful part to play in Hitler's new order in Europe; but it was early clear to the French that the part reserved for them under the Reich was that of menial service. Not only did the Germans keep over a million French prisoners of war captured in 1940 at work in Germany; they also, through Laval, set up the STO which compelled or was meant to compel many millions of young men to travel to Germany for forced labour also. It was the STO that created the *réfractaires*. No amount of good manners by the German occupying troops, whose record in France for drinking and wenching was by twentieth-century standards a fair one, could compensate for the removal from the factories and fields of the labour without which France's economy was bound to wither. The combination of STO, censorship, severe food shortage in the towns, and the reprisals that often attended early attempts at resistance created in the mass of the population of France – peasants, clerks, workers, professional men alike – a determination to get rid of the occupying regime at any cost.

The Germans thus decided for themselves that French opinion would reject them; but they still had an army of occupation, less and less willingly backed by the Pétainist police forces, to help them hold the population down. Who was to be the leader who would throw them out? For some years this remained uncertain; but the first candidate in the field remained there. Churchill had hailed him as 'the man of destiny' before ever the fall of France was complete.²¹ Everyone, or everyone outside the PCF, agreed that the leader of resistance would have to be a general. Weygand would not leave Pétain, Catroux and Noguès for different reasons would not come forward; Catroux indeed, like de Larminat, de Lattre de Tassigny, Legentilhomme, Cochet, *Leclerc*, preferred to serve under de Gaulle. Giraud came forward readily enough, delighted with himself for having escaped from German custody in both great wars, and was highly thought of by the Americans, who leant on him; he proved a broken reed. There was nothing left for the French but to rally behind de Gaulle.

General de Gaulle was already a proud, a sensitive and an honourable man before the spinning wheel of fortune brought him suddenly upward, in the summer of 1940, to a pinnacle where he could only remain if he could be great as well. The kind of greatness of which his character made him capable compelled him to preserve and maintain his pride and honour; and political circumstances joined to personal to compel him to adopt a fiercely independent attitude towards all other governments. He had a little Irish blood in him – his mother's mother was a MacCartan, descendant of one of the 'wild geese' who had fought for Louis XIV against Marlborough,²²

and once or twice, in the early days, he allowed himself an outburst of temper, discussing with some senior emissary of SOE some activity he chose to regard as outrageous. But he always took care afterwards to make it clear that he bore no personal animosity; and in the exceedingly difficult pass he had to fight his way through, his own conduct was always honourable and sincere. 'He had to be rude to the British', as Churchill said, 'to prove to French eyes that he was not a British puppet. He certainly carried out this policy with perseverance',²³ Attlee, in retrospect, went further: 'He was damned awkward. He always had to assert himself.'²⁴ It was an obvious move for Vichy and Berlin to proclaim that de Gaulle was a British tool, and in fact though pursuing purely French policies he was dependent on the British to an uncomfortably large extent. They provided him with most of the money without which all the resistance movements in France were bound to languish; they provided the wireless sets without which he could have no rapid communication with the field; they provided all the aircraft and almost all the ships that carried his agents to and fro. This made him the more determined to have policies of his own.

Not only was he dependent on the British for facilities; he could only use such staff as happened to be available. For all his notorious hauteur and alleged lack of diplomatic finesse he nevertheless managed his clandestine followers through four men completely unlike each other – Emmanuel d'Astier the lean, mercurial left-wing poet, Soustelle the young radical archaeologist, Koenig the hero of Bir Hakeim, and the inimitable Dewavrin. This was a feat in itself; but many of their subordinates lacked their competence, and painfully often lacked discretion as well. Dewavrin, the staff officer with whom SOE had most to do, had phenomenal capacities in political manoeuvre, and did not hesitate to use them throughout the war. We have his own word for it that he was not a *cagoulard* – that is, did not belong to an extreme right-wing body of Fascist and anti-democratic inspiration.²⁵ He was, in fact, a patriot and a good radical – in the English sense, not the French; though he was thought at the time to lean a long way to the right. After the war he was involved under his cover name of *Passy* in a series of furious newspaper quarrels, some arising from the contention that he tried to slant resistance in an anti-communist direction, some from an absurd tale that a Frenchman working with F section was enticed to *Passy's* headquarters in Duke Street and murdered in the basement; and in a controversy about funds.

But what were the British doing in all this? This question needs answers at two levels, day-to-day work in the field and high policy in Whitehall.

The vital political fact about SOE's British officers in the field was that they were British: therefore they were not going to be in any sort of power in France after the war, and could never be suspected of feathering their own or their friends' political nests. The same could seldom be said of the French agents who were men of any standing; in their highly political nation, everybody was expected to play some part in any political upheaval

that was in progress, a part dictated by his upbringing, his religion, and his party. And among the French, the communists felt themselves in party duty bound to do what they could to create a communist France. The narrative will make clear that SOE's agents, British or French, did not all take the same line about communism; why should they, in the days when 'our gallant soviet ally' was a platform catch-phrase, and only a few people as far-sighted as they were narrow-minded predicted a serious eventual menace from 'world communism'? Among the best F agents, some armed and supported communists – Pierre de Vomécourt in *AUTOGIRO*, Suttill in *PROSPER*, Peulevé and Poirier in *AUTHOR/DIGGER*, Southgate in *STATIONER*, Cammaerts in *JOCKEY*, for example; some worked with conscious or unconscious fellow-travellers; some tried to keep out of politics altogether like Cowburn of *TINKER* or Heslop of *MARKSMAN* or Brooks of *PIMENTO*. If any of these agents were operating in an area where there was sharp local disagreement between the FTP and the other armed resistance forces, they were practically bound to be drawn into this controversy themselves; this happened to Heslop, who narrowly escaped being imprisoned at the liberation as his principal local helper was. Only a few of the strongest agents – George Starr of *WHEELWRIGHT* is the outstanding example – managed to weld communist and anti-communist registers into a single effective fighting force.

It did not follow from the fact that an agent was a British officer that his integrity could not be impugned; this the narrative will establish. But not many British officers did turn out to be no good; and a large number behaved with exemplary courage, stamina, and discretion. Like most Englishmen, the English among them tended to think well of each other; an almost ludicrous example of this can be found in some notes on SOE tactics prepared in London in January 1945 by a staff officer considering work done in France: 'Where the object is strategic sabotage, only a small number [of men] are as a rule required for the actual operation. If the numbers are few, correct timing is easy; and as the most essential parts of the operation will be performed by British officers, the question of morale does not arise.'²⁶ They did make, as a body, a really marked impression on those parts of the French countryside they worked in. Almost all of them left behind them after the liberation scores of reliable helpers who had known them well and liked them much. The inherently fissiparous tendencies of the French divided them over and over again from each other, but did not keep them from uniting behind these trusted foreigners. Enormous stocks of pro-British enthusiasm were built up in France during the war by SOE's British agents and by the RAF crews who dropped supplies to resisters of all kinds.

To see what happened to this large credit balance we must turn to Whitehall. It is of course widely believed outside England that the British were in resistance for what they could get out of it: this is the view that other powers have always taken of them, and indeed is the view powers usually take of each other. Hostache may be taken as putting it in as hard a light as

a British reader can well stand; he suggests that the main object of British policy towards France, as soon as France was defeated in 1940, was to maintain her in a state of permanent subjection to Great Britain;²⁷ she was to be freed from Germany solely in order that the Norman conquest might be reversed and the writ of the English crown run again from Calais to Aquitaine. Unfortunately this is the sort of thing suspicious-minded historians like to believe. It may be worth mentioning that there is not a tittle of evidence to support this view in the archives, while there is massive evidence there of British sympathy for France and desire to see her great again. The British like to believe that in fact they were drawn into the whirlygigs of political activity in France by a succession of accidents, and did their best to sit outside the game, on the touchline. Looking back with the advantages of hindsight, and without the hindrances of groping through the fog of war and responsibility to find the correct decision that would deal with a mass of imponderables, people find it hard to believe that the British did not care who governed France after the war, nor attend to it. Of course they did care, and cared a lot; but who had time to think or to do anything about afterwards while the war was still raging? A few officials and staff officers, of particularly keen political sense coupled with unbounded energy, might try to play politics; Dewavrin and Jacques de Guélis provide examples. But anyone who tried to play politics while everyone else was trying to get on with the war would become suspect, as Dewavrin in London on the French side and de Guélis in Algiers on the British did. The sole conscious British political aim in France was to remove the nazis so that the French could govern themselves as they wished. This in practice meant being anti-Pétainist, and this political attitude all SOE's staff were ready to accept. But – an individual freak or two apart – there was never any positive alignment between any branch of SOE and any French political party, war or pre-war. This is what is meant by the often repeated, often doubted assertion that SOE was 'apolitical' in France. Curiously enough, it was widely believed in France during the war that the British government wanted to bring back the third republic, although the British ruling class had mistrusted it ever since the mutinies of 1917 and were delighted to see it go. To think this is as absurd as to suppose that Churchill and Eden wanted to set up a communist France.

What the British wanted above all to do was to re-establish in France an open society in which free men could govern themselves as they chose. It is to some extent fair to say that British policy was anti-communist; a majority of British conservative and official opinion doubted – even then – whether a communist society could also be an open one; in 1944 this was a point open to argument. Unless free men could be provided with arms they could not resist the Germans, or help to evict them; but unless the men were there to pick the arms up, it would be useless to drop them. SOE's main task was to provide reliable receptions and so make the parachuting of arms into France worth while.

All British government departments did not see eye to eye about the way to treat French resistance in general or de Gaulle in particular. There are some traces of a departmental difference of opinion between the Foreign Office on one side, and SOE and the chiefs of staff on the other. General de Gaulle had no legal standing intelligible to accredited diplomats till late indeed in the day. And in any case the Foreign Office, pursuing its secular policy of remaining on good terms with the powers that be, entered early into negotiations with the Vichy government: 'not' as Churchill put it 'because I or my colleagues had any respect for Marshal Pétain, but only because no road that led to France should be incontinently barred'.²⁸ In spite of many rumours to the contrary, these negotiations never came to any tangible conclusion; that is, there was never any written Anglo-French accord. On the other hand, each government in fact did a little to let the other be: up to 1942, the British allowed a certain number of American food ships into southern France, and in return for this sustenance the Vichy regime clamped down on the nastiest excesses of its anti-British propaganda. A mild *modus vivendi* of this kind was not of course readily compatible with full support for de Gaulle; and when Vichy territory was entirely overrun by the Germans, it went by the board.²⁹ Thereafter, Foreign Office policy and SOE's could take much more nearly parallel courses; though Baker Street generally displayed more gaullist leanings than Whitehall.

The Ministry, or rather the Minister, of Defence was at first a strong supporter of de Gaulle. As he was also Prime Minister, and a Prime Minister of Lincoln-like power over his Cabinet, he had his own way as a rule. Spears has recorded that at the very beginning, on 17 June 1940, he 'took de Gaulle to Downing Street, Winston was sitting in the garden enjoying the sunshine. He got up to greet his guest and his smile of welcome was very warm and friendly'.³⁰ However, Churchill's temper was as strong and as hasty as the general's own, and their relation during the war was one of amity punctuated by intermittent rows, some of them of substantial size.³¹ But they always healed their quarrels; for without Churchill's support de Gaulle could do nothing at all, and without de Gaulle's support as Churchill came to realise he could not mobilise the French against the enemy.

SOE at first was neutral, as between possible leaders of French resistance. Dalton indeed, as a strong theoretical socialist, shared the ideological dislike of generals in politics that had been a marked feature of the French left since the days of General Boulanger – or General Bonaparte. But when the earliest raiders came back in the spring of 1941 and reported how widespread was the support that they had found for de Gaulle in northern France, the staff began to incline towards him. Gubbins particularly became a firm gaullist from that time: he felt that this was someone with whom serious business could be done. The celebrated practical common sense of the British thus came to be enlisted on the side of a man whom they had at first inclined to shrug off as an impracticable visionary.

As will become clear, in the early days de Gaulle's predominance in France remained uncertain. Great Britain simply dared not risk the emergence in France of some quite unknown and incalculable resisting force; to this extent, and to this extent only, F section agents were tools of an independent British policy. They were sent into France to organise 'independent' resistance groups among such supporters as they could find. So far as the two are ever distinguishable, their role was military and not political; and in 1941–42 they often found supporters who were passionate in their opposition to de Gaulle. Yet most non-gaullist resisters fell by the wayside in one way or another; either they were arrested and deported, or the fabrics of their movements turned out insubstantial. By 1943, the cause of anti-gaullist resistance, though not yet buried, was dying. In 1944, all SOE's agents working in France – the Poles and the escape lines apart – were amalgamated under the amorphous staffs of EMFFI and SPOC. Many of the French members of EMFFI were regular army officers who had recently changed sides and arrived from north Africa, and some of their British senior colleagues found the headquarters nauseatingly full of intrigue. But at the level at which the work of supply and resupply of circuits and agents actually got done, too deep under the pressure of work to be affected by surface turbulence, everybody tried to get on with the business of war without bothering about politics or personalities.

In sketching SOE's structure for work into France, and the political background, it has sometimes been necessary to refer to particular operations; an attempt must now be made to summarise them all. To disentangle a myriad of individual and collective exploits into intelligible patterns has been a task of some complexity; but reader and writer alike would be bored by a mere catalogue of names and dates, masquerading as a text.

De Gaulle himself could never be persuaded to distinguish the British security, intelligence, interception, escape, and sabotage organizations;³² and most Frenchmen have followed him, then and since, in attributing all British clandestine work to the machinations of a single 'Intelligence Service' of indefinite range and legendary power. Cowburn refers ironically to this 'vast esoteric, omniscient organization commanding unlimited means of action', directed by 'the long-term cunning of anonymous super-schemers, who worked somewhere in the Foreign Office and concealed their activities by appearing at fashionable Mayfair tea-parties wearing the most stupid expression on their faces and talking only about horse-riding, grouse shooting and memories of their days at Oxford or Cambridge';³³ the reality was far from the myth. SOE's purpose was subversive, not informative. Naturally a great deal of useful intelligence came its way; a few of its coups in this respect will be noticed below. But its main functions were different; they were two, sabotage and the raising of secret armies. Either nicely calculated risks were taken by clandestine agents to destroy particular targets – perhaps

in themselves quite small ones – of strategic value to the enemy; or else the agents devoted themselves to building up hidden guerilla forces which would come out into the open when London gave the signal and help to throw out the Germans. It will be clear that an agent's contribution to either task might well be indirect: it is time to get down to details. Reading the files in which some of these exploits are recorded has sometimes seemed like reading a series of plots for improbable thrillers. Out here on the lonely margins of military life, heroes seem more heroic and blackguards more blackguardly than they do in the ordinary line of battle, where companionship keeps men steady and women were not then expected to fight at all. Many of the bald and halting accounts of unimagined achievement call to mind John Buchan's remark prefixed to *Greenmantle*, that SOE-style struggle of an earlier war: 'Some day, when the full history is written – sober history with ample documents – the poor romancer will give up business and fall to reading Miss Austen in a hermitage.' A number of these tales may have occurred to Churchill when he spoke of the achievements of SAS and other voluntary special forces: 'we may feel sure that nothing of which we have any knowledge or record has ever been done by mortal men which surpasses the splendour and daring of their feats of arms.'³⁴ Not all the tales were splendid; not all the agents were daring; this the narrative will make clear enough. And I have tried to say, with Kipling, 'So far from doctoring or heightening any of the incidents, I have rather understated them.'³⁵

Nevertheless some of the incidents and coincidences were decidedly odd; and many of them show that in a way the French are right to regard the effort to resist the Germans as a single one. One or two examples may be given here. In spite of all the care taken in London to keep services and circuits apart, AUTOGIRO the first big F section circuit in northern France was betrayed to the Germans by a Frenchwoman who belonged to INTERALLIE, a Polish intelligence network; this same woman's activities led to the downfall of OVERCLOUD, a promising RF section venture in Brittany. Her lawyer, Brault, through whom the F organizer made contact with her, escaped from the double disasters of INTERALLIE and AUTOGIRO; retired to the south of France; appeared in London early in 1944 as the emissary to RF from the main Rhone valley resistance movements; and succeeded, even more than Yeo-Thomas or d'Astier, in persuading Gubbins, Selborne, and Churchill himself that a special effort to arm the largest maquis was worth while. Again, Yeo-Thomas's principal assistant when he went to Paris on RF business normally worked as cipher clerk to an escape line that had no connexion with SOE.³⁶ Yet again, when the PHYSICIAN organizer, *Prosper*, got to work on the replacement for AUTOGIRO that came to be named after him, its tentacles soon reached from the Ardennes to the Atlantic; many other F organizers in France at the same time had close contact with him; and so when his circuit fell, it fell hard. Most of the R.F organizers in the ZO knew of him as well, if they kept clear of him. FARRIER, Déricourt's F Lysander

circuit, an organization overlapping PROSPER, was eventually suspended on hints that it was unreliable that came from RF as well as F agents and also from outside SOE, and was then wound up because of crossed wires, at home and in the field, between three of SOE's sections. SAS and OG parties in France after D-day cared not at all for SOE's careful compartment system, and armed anyone who seemed ready to fight. Other instances will appear below. It needs to be made clear that only SOE operations inside mainland France are covered; and not quite all of these. France being where it is, naturally a sizeable number of agents heading for other countries wanted from time to time to cross it; but little account is taken of them,³⁷ for there is more than enough to discuss as it is.

One or two other general points need to be made by way of preface to the following chapters.

The first and most important of them is that the French saved themselves; the British and, later, the Americans gave them the means to do so, but could not give them the will. All over France, from the moment of German conquest onward, individual Frenchmen and Frenchwomen determined to resist; gradually, spasmodically, they coagulated into more or less well organized groups. Highly educated and articulate people, fond of organization for its own sake, they tended to arrange themselves in grades and categories, and to squabble about who was to do what before they had the weapons to do anything. Outside France, the exiles in London and later also in Algiers – the leaders of 'external resistance' – occupied themselves incessantly with devising unstable hierarchies of command and control for the forces of 'internal resistance', many of which long refused to acknowledge any external authority. The external groups could do nothing without communications, which were at first wholly in British hands, and never – some submarines apart – in French ones; the internal groups could do nothing without arms. This was where SOE came in.

Gradually, and after many false starts, SOE's agents were inserted into France, and brought with them the promise of arms to come. It was not till the spring of 1941 that any of the agents arrived at all; not till the summer of 1942 were they in appreciable numbers. By then they had attracted Hitler's personal attention, but not till the beginning of 1944 did they seriously worry the Berlin or the Paris SD. Yet in the end they swamped the German security forces who imagined they were under control. Nearly half France lies south of a line from the Loire's mouth to Dijon, and west of a line from Dijon to Nîmes. A few coastal pockets apart, this area was controlled by the end of August 1944 by its own inhabitants, bearing SOE's arms in their hands. Only a few score SOE, SAS, and OG parachutists and some armoured car patrols from the main allied expeditionary forces were there to help them; though obviously if the allied expeditionary forces had not advanced as they did, the resisters' opportunity would never have arisen. The bulk of the area they freed was thinly held, and what freed it was rather

the Germans' withdrawal than their own activities. The Germans had to pull out, lest the invasions of Normandy and Provence link up behind them and cut them off. Yet they did not withdraw unhampered; sniping was almost universal, ambushes were frequent, set-piece attacks and large German surrenders were not unknown; and most of this substantial area believed it had liberated itself. Near the main battlefields, again, armed resisters were to be found, astride the enemy's communications at every nodal point: cutting telephone cables, immobilising breakdown cranes, laying ambushes, sniping generals, demolishing bridges or preserving them from demolition, performing these or any other indispensable tasks with SOE material according to orders passing by SOE wireless, or, by arrangement with a BCRA or an SOE organizer, by the BBC.

In the end, in fact, the resources devoted to SOE's effort in France produced an invaluable dividend; and there had been numerous interim payments already. No clear line could as a rule be drawn between agents who were in France for specific purposes of sabotage and those who were there for general purposes of subversion; let alone the impossibility of distinguishing who were and who were not agents of SOE at all. Circuits often overlapped, as we saw just now; also, obviously enough, they varied enormously in size. The smallest, F's TUTOR, hardly deserves the name; it consisted of one single man who spent less than a week *en mission* in France. The largest, the native OCM or FN or COMBAT which worked with RF, or F's AUTOGIRO, PROSPER, WHEELWRIGHT, MARKSMAN, reckoned their available forces in tens of thousands, and the latter two achieved the victories AUTOGIRO and PROSPER could only dream of: WHEELWRIGHT took Toulouse, and MARKSMAN liberated the better part of three departments on the Swiss border. It is important that readers should keep these reservations in mind when looking at the time-chart of F's deployment at Appendix H,³⁸ and remember that though the circuits all look alike on the diagram, they looked and felt very different on the spot. Otherwise, they will compare incomparables and mislead themselves. The diagram's main use is to show which circuits were working when, and how long or how short a time each of them lasted. The index will show where each is discussed in the text.

It can be seen at a glance that as many as fifty F section circuits were present in good fighting trim when their areas were liberated – either directly overrun by the invading armies of OVERLORD and DRAGOON or abandoned by the Germans the resisters drove out. While it is true that half of these fifty circuits had not begun till 1944 – seven of them in fact, not till after OVERLORD D-day – it is also true that seven of them, including one of the latest comers, were commanded by stalwarts who had been in the field in 1941.³⁹ Another dozen had organizers who had started their F section clandestine experiences in 1942; one of these people, Tony Brooks, had been operating PIMENTO continuously since July 1942, except for ten weeks in England and three nights in prison. These figures go to show that in SOE

as in other combatant units – fighter squadrons are a good example – if you could survive your earliest dangers you grew wily, and might last long.

Of F's 43 circuits extinct by the time France was liberated, ten had withdrawn from the field on London's orders, thirty-one had been destroyed by enemy action – six of them before they had got going at all – and two had broken up from internal stresses: LACKEY, a small circuit in Burgundy, and the much more widespread if little more effective CARTE, which a purist might maintain was never an F section circuit at all.⁴⁰ The time-chart also shows how several circuits could be withdrawn, and then re-inserted in the field; and how well some could survive the death or imprisonment of their leaders.⁴¹ A similar time-chart cannot usefully be provided for the other sections working into France; one for the JEDBURGHs' three months' activity would hardly be significant, and the evidence available for DF's, AMF's, and EU/P's work is too scanty. RF's important work was – in spite of the love of order that is a proverbial French characteristic – never as orderly even as F's often untidy arrangements, and does not so readily lend itself to presentation in visual form.

Reservations must also accompany the maps. A very rough attempt has been made to show the zones of influence of the more important F circuits in August of 1942, 1943, and 1944; so long as the reader remembers that they provide the merest outline guide to the circuits' whereabouts, they will not be too misleading. These maps are not of the same kind as geographical, political, or military maps; they are diagrams of spheres of influence, not precise indicators, and no one should feel that they indicate the sort of territorial influence that feudal barons wielded.⁴²

The division of the narrative into chapters by the calendar will also seem artificial; but the artifice does represent some reality. For many circuits there were two seasons in France, as there had been in Caesar's day: a campaigning season, and a time to go into winter quarters, making plans and preparing equipment for the spring. Weather often hindered winter supply; and while no one would pretend that winter weather was as severe in France as it was on the Leningrad front or off the coasts of Iceland or north Norway, it was often bad enough to hamper severely the night activities of agents and sub-agents who had to maintain some ordinary civil employment as cover.

One other feature of what follows will seem odd, particularly to people used to reading military history. They may already, unconsciously perhaps, have equated F and RF sections with battalions, and DF and EU/P with independent companies; but these analogies with ordinary army life do not hold at all. Companies and battalions operate as units; SOE's agents operated as individuals, or in very small squads. The largest groupings of British-trained agents in France hardly came up to the strength of an infantry platoon – Suttill (*Prosper*) was more or less in charge of nearly thirty agents, and George Starr of WHEELWRIGHT had at one time over twenty under his command; but not even in the PROSPER circuit did so many agents assemble together in one

place. Individual squad activity was an essential feature of SOE operations, till open guerilla broke out after D-day; right at the end, in August and September 1944, two missions each two dozen strong went into western France, but these were special cases.

The clearest example of the value of small squads comes from outside France. Knut Haukelid and eight companions put paid to the whole German heavy water plant in Norway;⁴³ an action which by itself might have sufficed to justify the existence of SOE, for it helped to keep the Germans' plans for building nuclear weapons in confusion. Had Germany solved the problems of nuclear fission before the allies, recent history would be different indeed.⁴⁴ None of SOE's activities in France was of comparable import; but several had a noticeable effect on the course of the war, ARMADA might be singled out: a quartet of RF's saboteurs between them closed all the canals by which the Germans were sending torpedo-boats and midget submarines to disrupt the allied landings in Italy, which thus just succeeded instead of just failing.

Over and over again SOE's operators provided instances of the lever-principle at work in war: small impulses applied at carefully chosen points had large results. Hence what must at first glance seem to be a number of mere adventure stories below. They had some pattern; and if the reader has the patience to read through to Chapter XIV there will be a summing-up.

VII

Opening Gambits: 1940–1941

During the disasters of the battle of France in May and June 1940 SOE did not even exist. It was only set up in mid-July, and was still puling in its cradle in August and September, while the Germans were fighting the battle of Britain and providing sabotage targets of high priority in the ports and aerodromes where they were getting ready their invasion, which they had to cancel because they could not command the sky. Their preparations in France were disturbed only by such aircraft as bomber and coastal commands could muster, and by a few uncoordinated acts of despairing heroism by Frenchmen who could not bring themselves to accept the fact of defeat. As early as 7 August 1940 German main headquarters in Paris was receiving complaints of French sabotage activities, and a circular on repressive measures against them, including curfew and the seizure of hostages, was issued by it on 12 September.¹ We have seen already the attempts made by MIR at active operations into France during the collapse: the achievement, one splendid fire, was minimal, considering the size and variety of targets that would have been available had any organization been ready to attack them, MIR's own appreciation of what was going on, completed on 4 July – the day after the naval disaster at Mers-el-Kebir – still laid down that the first object of British defensive strategy must be to capture or destroy the French fleet;² but no one in MIR could do anything towards achieving this, and in any case that branch was soon broken up. Most of its remaining staff were absorbed into SO 2, and the department ceased to exist in October.

The fact that no organization was ready provides one more instance of the Chamberlain government's unreadiness for war. But to be unready for subversive war is part of the price that free societies sometimes have to pay for their freedom. It is really less easy to excuse the continuing indecision about what SOE's role ought to be, after it had been set up. As has been indicated already, most of its first year was wasted in arid and intricate disputes about

what it ought to do. Its roles in relation to military intelligence, political warfare, propaganda, coastal raiding operations, and indeed grand strategy were all unclear, all open to dispute, and all for a time the prey of contending parties of officials outside it who felt their vested interests were threatened, or who simply enjoyed intrigue. Wrangling held up development through the autumn and winter. It looked for a time as if SOE would be trapped for good in a vicious circle, as MIR had almost been; because it had no positive achievements to show, it could make no progress against its enemies at home; and because it could make no progress against its enemies at home, it could prepare no positive achievements.³

Nelson's initial difficulty was that the existing methods and staff of section D required a radical overhaul, including a change of chief. In general, Nelson saw 'no possibility of any quick results of a major type'.⁴ As Gubbins put it in retrospect, 'There was no contact between Britain and any of the occupied countries: nothing was known of the conditions inside those countries except from occasional reports from the few who still managed from time to time to escape'. Everybody connected with SOE was displaying 'tremendous enthusiasm'; but it was not yet channelled in any useful direction.⁵ It was not till 25 November 1940 that Nelson received his first directive from the chiefs of staff. This document derived from a conversation they had with him and Jebb a fortnight earlier.⁶ It consisted largely of blinding glimpses of the obvious – the need for subversion to fit in with the rest of strategic policy, the importance of not disclosing future intentions to the enemy by injudicious concentration on particular areas, and so on. Its authors hoped that Germany would be so weakened by subversion that eventually a land striking force could be sent across to defeat her; but meanwhile it was hardly possible to indicate particular targets for sabotage. Subversive activity needed, they thought, to be prepared over wide areas, to be implemented later as occasion arose. They specified service communication targets as important; and directed, though not at high priority, the setting up of some organization that could co-operate with an eventual expeditionary force in Brittany, the Cherbourg peninsula, and south-western France.⁷

Behind the level tone and commonplace phrasing of this paper there lay implicit a main guiding concept in SOE's strategy all through the rest of the war. This was, as we have just seen, that operations should be of two distinct types; each called for different qualities in the agents who carried them out. They might be coups de main – acts of straightforward sabotage, the destruction of key objects in the enemy's military or economic system, such as a telephone switchboard serving a group of headquarters or a transformer providing power for a group of factories. Or, on a larger scale and on a longer term, they might consist in the organizing and arming of secret forces of local inhabitants, who could come out and harass the enemy by guerilla operations whenever such activity would most benefit the allied strategic plan. In practice it was seldom feasible to maintain such a secret army in a

state of prolonged inaction – its members either found some fighting to do, or dropped away. So SOE's organizers of clandestine groups kept their followers' hands in by conducting occasional coups de main, often as much for training purposes as for the effect these acts of sabotage would have on the enemy. The strategic usefulness of such efforts varied of course with the closeness of the organizers' touch with London, the armament available, and the extent to which present activity might imperil future possibilities by attracting too much attention from the other side.

All this will be illustrated in the pages that follow; in the autumn of 1940 everything was doubtful. But by the time the chiefs of staff's paper of 25 November was issued, to its strictly limited circulation of ministers and senior staff officers, SOE's first successful French operation was already on the way to its target. It had been preceded by a few failures, which are worth passing mention. Just before the fall of France, section D sent a flying-boat to collect de Gaulle's family from Carantec, on the north Breton coast near Morlaix; it disappeared. Early on 20 June a D staff officer reached Carantec by MTB, only to find that the Germans had arrived, after Mme de Gaulle had left; she reached England by more orthodox means.⁸ A few weeks later, on 1 August, the section managed to embark three Frenchmen, Victor Bernard, Clech, and Tilly, on a slow and noisy motor launch; it was to land them just across the estuary from the same spot. But the launch ran accidentally into a German coastal convoy in the small hours, and withdrew under fire.⁹ On 11 October a further unsuccessful attempt was made to land two agents by MTB.¹⁰ And on 14 November, the night Coventry was burned, an agent went over again, to the Morlaix neighbourhood, this time by air; but he refused to jump. (In accordance with standard practice, he was at once 'returned to unit' – in his case to de Gaulle's headquarters; where he did well.¹¹) It was in a way unfortunate that this, the only recorded refusal among all these air operations till August 1944,¹² should have been at this critical opening stage; but a timid agent would hardly have made a good opening organizer.

SO2's run of ill luck did not last; operation SHAMROCK, though small, was undoubtedly as the war diary put it 'colourful and extremely successful':

Five agents under the direction of Lt. Minshull, RN, were conveyed by submarine to the Gironde. In the Estuary, they seized a French tunny fishing smack, impressed half the crew, and placed the remainder on the submarine. After a successful reconnaissance to observe the procedure followed by U-boats in entering and leaving the river, they sailed the fishing boat back to Falmouth without incident. The information procured by personal observation and by the interrogation of the French fishermen proved of great value to the Navy and the RAF, and it is understood that successful operations based on this information were shortly afterwards undertaken.¹³

Even a war diary can be in error: this one was, as was Minshall in his own war story. The coup was not in the Gironde estuary at all, but off Lorient, near the Ile de Groix.¹⁴ It will be noticed that SHAMROCK was primarily an intelligence operation, rather than the sort of subversive activity that SOE had been intended to perform; its commander belonged to the navy and not to SOE, and his crew were borrowed from the nascent Free French organization in London. That it took place at all was cheering for SOE's staff, but the organization was not asked to repeat this type of coup: the Admiralty preferred less violent means of getting intelligence.

The gaullists meanwhile were hard at work building up their quite distinct organization in France. Within a month of the armistice they had sent their first agent back; by the turn of the year they had the Catholic Renault-Roulier (*Rémy*)'s intelligence circuit called CND well organized, and others starting up,¹⁵ and were recovering from the humiliation of their failure at Dakar (*MENACE*) in late September – a knock-down, but not a knock-out, blow to their prestige. As far as these pages are concerned only one aspect of *MENACE* mattered; but that mattered a great deal. The secret of the enterprise seemed to have been exceptionally badly kept. Dozens of ludicrous stories about indiscretions in shops and bars went round London as soon as the operation was over, and some may well have gone to Vichy before it began: from that dismal autumn to the end, British staffs remained reluctant to pass secrets to the Free French if they could help it.¹⁶ There is indeed a rumour that the Germans had a more than competent intelligence agent, ensconced in some quite senior post close to de Gaulle, who provided them with information right up to the winter of 1944–45. If this is true, it justifies many British suspicions, but I have discovered no hard evidence for or against it.¹⁷

SOE had an individual reason for distrusting the Free French on top of the general fear that they were insecure. Like most other powers, the gaullists aimed at employing a single secret service; and the arrangements they proposed for Lagier (*Bienvenue*)'s nascent *Service Action* within it horrified the cautious men who dominated SOE's early days. The leading French concept was that a secret army could be made to grow out of the intelligence *réseaux* that Dewavrin was already busy forming; and to grow, moreover, in a way that seemed especially designed to assist the counter-espionage services of the enemy and provoke disaster rather than success. 'We don't want observers', Dewavrin explained in describing the type of agent he proposed to send to France; 'we want men who can find us as many informants as possible; informants who can tell us exactly, without going out of their way, what they see, what they know, and what interests us. So our agents will have nothing to do but collect these fragments of information, assemble them by subject, and pass them across to us with the minimum of delay. Their functions will be confined to administering their circuit and organising their communications.'

'I saw a second advantage in this system', he added in a later retrospect, unknown to the British at the time; '... it would re-establish communications,

up and down the country, between groups whose very existence was bound to lead them to snowball, and so to favour the flowering of a larger resistance movement. This movement would persuade our allies, through its breadth and size, that all France would come back into the battle, bit by bit.¹⁸ The very thought of a circuit snowballing made every officer in Baker Street shudder: the process, never in the British view desirable, was only admissible at all in the very last stages before the area concerned was overrun by a victorious allied army; and then only if ample hidden arms could be produced for the outer flakes of the snowball by the clandestine organizer at its core. Moreover, as Humphreys observed in this connection, it was easy to 'visualise times when British military policy would be opposed to French political opinion'.¹⁹

Nevertheless, the Free French had to be accepted as a fact of politico-military life; and they were as anxious as anyone else to make a start on active operations into France. They provided the seamen for SHAMROCK, and they formed an independent parachute company trained by SOE²⁰ to carry out airborne coups de main; but for methods of getting any part of it across to France they had to rely on the British – specifically, on SOE. 'In fact', said Dewavrin, 'we had practically no means, while the English had everything available.'²¹ De Gaulle accepted this with an ill grace, but no alternative was open. SOE accepted the Free French with rather less reluctance for the next operation; they also had no alternative. This was SAVANNA, a formal failure but a virtual success.

At the end of 1940 the Air Ministry asked SOE to disrupt Kampfgeschwader 100, a German bomber formation stationed at Meucon airfield near Vannes in south Brittany which specialised in raising target marker fires by beam navigation; it was the German pathfinder force, the spear-head of the nightly battering of the British Isles. All its pilots were reported to go out from Vannes to Meucon every evening in a couple of buses; would SOE kindly arrange an ambush? Time pressed. F section had no one ready. Gubbins and Barry took the operation over, and asked for some French parachutists; de Gaulle and Dewavrin quickly agreed. But de Gaulle was having a bad spring, and more than once later forbade his men to take part in an operation of which full details were not disclosed to him or his staff; viewing Dakar, full details could not possibly be disclosed,²² and he was only talked round with difficulty. Portal and Harris²³ also introduced a last minute hitch, by trying to insist that the party dropped in uniform: as Portal put it to Jebb, 'I think that the dropping of men dressed in civilian clothes for the purpose of attempting to kill members of the opposing forces is not an operation with which the Royal Air Force should be associated. I think you will agree that there is a vast difference, in ethics, between the time honoured operation of the dropping of a spy from the air and this entirely new scheme for dropping what one can only call assassins.'²⁴ By the time these obstacles had been overcome, the February moon had waned; weather early in March

was bad. At last, on the evening of 15 March 1941, five French soldiers emplaned in a Whitley; they took with them two containers of small arms and a ‘road trap’ designed particularly for them.²⁵

They dropped blind at midnight, some eight miles east of Vannes and five miles from the intended spot, under cover of a light bombing raid on the airfield. At dawn they buried their gear and set out to reconnoitre.²⁶ They soon found out that KG 100’s pilots no longer travelled by bus, but in twos and threes by car; their task therefore could not be fulfilled. But Bergé, the thirty-year-old regular captain in command, saw no reason to waste his time in France, and dispersed his party on further reconnaissance. One stayed near Vannes; one, Letac, went to Brest; one was already missing; Bergé himself and the fifth, Forman, went to Paris, Nevers,²⁷ and Bordeaux. They were all to meet again at Sables d’Olonne on the Biscay coast at the end of the month.

Another one went missing meanwhile; but Bergé, Forman, and Letac reached the rendezvous. After several nights’ fruitless vigil in the dunes some miles north-west of the town, eventually on the night of 4/5 April they met Geoffrey Appleyard who had come by canoe from a submarine to take them off. The sea was so rough that two other canoes had been stove in; and Letac had to be left on the beach. Bergé found himself with ten days’ leisure in *Tigris* while she finished her patrol, which he spent compiling a report on his party’s instructive failure.²⁸

SAVANNA, like MIR’s abortive landing near Boulogne, achieved nothing directly, but proved that a method was viable. It showed that subversive agents could drop into occupied France quite unobtrusively, move about inside it with reasonable ease, be welcomed by a decent proportion of the French, and – given time, bravery, trouble, and luck – be extracted. And its leader brought back to England a mass of intelligence about living conditions – curfew rules, bicycle regulations, cigarette prices, identity papers, ration cards – which SOE had vainly sought for months to discover. It is a melancholy comment on the lack of confidence between SOE and the normal sources of service intelligence, or on those sources’ inadequacy at the time, that it was not till Bergé’s return that SOE discovered such simple if transitory facts as the continued suspension of the Paris taxi service since the occupation, or that railway travel in general was ‘very easy and entirely uncontrolled’.²⁹

Many things hitherto hazy now came into focus, and continental operations could be confidently launched.

It was not till the smallest hours of Anzac Day, 25 April, that the next successful landing took place, without a moon, as it was by sea. The carrying craft was HMS *Fidelity*; the beach was by the Etang du Canet, just north of the eastern end of the Pyrenees.³⁰ The passengers were sent by different sections for different purposes. One was a Polish travel agent called Bitner,

using the alias of Kijakowski; his task was to reconnoitre the Polish community in north-eastern France, and report on its resistance possibilities – to the Poles direct, of course, not to SOE. SOE's contributions to his expedition, made through EU/P section, were two; they suggested the idea, and persuaded the Treasury to provide the money. Bitner made contact with Kawalkowski, formerly Polish consul-general in Lille, the leading figure there, and they soon began to ask for money, wireless sets, and propaganda material; not, it will be noticed, for arms. (Kawalkowski was known to the Poles as *Bernard*, in SOE as *Hubert*, and in France as *Justin*.) Bitner, who became one of his main helpers, spending most of the rest of the war in France, fell into German hands in the summer of 1944, resisted torture, and escaped from a train heading for Germany.³¹

The other passenger, Rizzo, was working for clandestine communications, in a typically unostentatious way. Humphreys had twice visited Lisbon during the winter, investigating several of the lines for passing letters, parcels, and people into and out of France that were said to exist; most of them he found either non-existent, or unsuited to SOE's purposes.³² He established in Lisbon L. H. Mortimore who remained the sheet-anchor of his effective lines for the rest of the war. Through Mortimore, he was in touch with Brochu of the French general staff, whom he had known in Paris; Brochu talked of forming sabotage groups, but nothing came of this.³³ Humphreys doubted the efficiency and the security of many of the people he looked into, and decided to start sending in men of his own. E. V. H. Rizzo (*Aromatic*) was the first of these. An elderly Maltese civil engineer, working as a science master in a Paris school till June 1940, he had bicycled over 1,500 kilometres to get away from the Germans he detested.³⁴ He knew the neighbourhood where he was put ashore, and went to ground at once in a quiet suburban house in Perpignan suitable to his timid manner and odd appearance. No one in France could take him for a Frenchman, but in the eighteen months he stayed there this donnish figure made some highly unacademic contacts with the Pyrenean smugglers, and 'created a remarkably good line which worked successfully for four years and was never blown to the enemy', for he was keenly security-conscious.³⁵ In the course of time this line, variously known as EDOUARD or TROY, grew to be the second largest of DF's French circuits. Much of the courier work for it was done by Rizzo's wife, an excellent woman, who stayed on after he left, eventually fell into German hands, and was gassed at Ravensbrück on Good Friday 1945.³⁶

Unknown either to Bitner or to Rizzo, the man in command of the skiff that had taken them ashore from *Fidelity* was himself captured a few hours later, and thus launched accidentally on one of the most celebrated clandestine careers of the war. He was a Belgian army doctor called Albert Guérisse, disguised already under the rank and name of Lieutenant-Commander Patrick O'Leary, RN. He soon got away from his French captors, and established the PAT escape line in which three of F section's best

couriers served their clandestine apprenticeship – Andrée Borrel, Madeleine Damerment, and Nancy Wake. This line eventually carried over six hundred members of the allied forces – most of them shot-down aircrew – back from hostile territory to fight again. His ‘sustained courage and devotion to duty beyond all normal praise’³⁷ not only kept the line in being, but preserved his own integrity in the face of torture and concentration camps after his betrayal to the Germans in March 1943; eventually he was liberated from Dachau.

To avoid incessant chopping and changing between sections, we may dispose here of four other early agents of the DF, or clandestine communications, branch of F section. (As was said on page 94, DF hived off as a quite autonomous section in the spring of 1942. Humphreys was using the symbol DF in correspondence with Marriott as early as April 1941.³⁸) One calls for special notice. The title of ‘first woman agent sent into France’ was popularly awarded to Yvonne Rudellat, who did not arrive there till July 1942. She was preceded by fourteen months by Giliانا Balmaceda, a young actress whose husband Victor Gerson (*Vic*) will play an important part below: he made as many as six separate clandestine visits to France, where he built SOE’s best and biggest escape line. His wife happened to be Chilean by birth, and to have a Chilean passport bearing an unexpired visa for Vichy France; and she paid a three-week visit there at the end of May and beginning of June 1941, staying at Vichy and Lyons, and returning with pedestrian but invaluable information about timetables, curfews, the papers civilians had to carry, and the extent of bus and railway controls.³⁹

Two other early DF agents shared another unusual feature: they refused to accept any salary, and could only occasionally and with difficulty be persuaded to accept even their travel expenses, which were high. Both went in and out of France from neutral countries as couriers; one from Portugal and one from Switzerland. One was Daniel Deligant (*Defoe*), a French Jew who lived in Lisbon and often visited France on business. He several times took messages and wireless sets for SOE, from June 1941 onwards, and would deliver them wherever he was asked, on either side of the demarcation line, over which he organized an efficient crossing service.⁴⁰ The other was a Swiss social democrat, René Bertholet (*Robert*), who made numerous journeys between Berne and Lyons in 1941 and 1942, carrying messages and making inquiries. Neither ever came under any suspicion.

The fourth DF contact, also a business man, was a Norwegian quaker shipbroker called Holst (*Billet*) who had an English wife and a head office in Marseilles. He was recruited into SOE by a fellow Norwegian in the spring of 1941; behind his ponderous appearance he kept a swift intellect, a painstaking character, and a strong dislike of the nazis. He was able to put together several useful lines for passing messages and parcels round south-west Europe. These lines, like EDOUARD, remained intact throughout the war.⁴¹

Other sections were less inclined to be unobtrusive; a brisk search for coup de main targets went on that spring. Attacks of the SAVANNA type were planned against U-boat crews at Brest and Lorient and against Condor Atlantic raiding aircraft at Mérignac by Bordeaux;⁴² none of these reached the starting gate at first, but one aimed at the next-door suburb to Mérignac did. The target here was the Pessac power station, which Cadett of F section was 'particularly keen on' attacking at the turn of the year.⁴³ But his section again proved unready. MO section took it over, and Barry prepared a team of half a dozen Poles to tackle it. They set off on 10 April from Tangmere; but an electrical fault released their two containers over the lower Loire, and they had to turn back. The aircraft crashed on landing, killing some of the crew, bursting into flames, and wounding all the Poles; and it was the only one fitted to drop containers.⁴⁴

Gubbins next turned to RF section, which he established in the process of preparing this operation hurriedly. Another Whitley was soon modified by the RAF; and Barry, Piquet-Wicks, and Lagier jointly briefed a trio of French parachutists: Forman, lately back from SAVANNA, Varnier, and Cabard. They dropped blind near Bordeaux on 11/12 May, buried their container, and reconnoitred their target; they were dismayed to find a high-tension wire just inside the top of its nine-foot boundary wall, heard people moving round inside, did not manage to get hold of bicycles for a silent get-away, lost heart, and gave up. Fortunately, as it turned out, they missed the submarine they were to have met near Mimizan, and went off to Paris; where Forman managed to meet Letac (he had been given a possible contact address before he left England).⁴⁵ Joel Letac had made two more reconnaissances of KG 100's pilots and their transport, with the help of his brother Yves; neither had any useful result, and he had abandoned SAVANNA. But he would not hear of abandoning JOSEPHINE B, the attack on Pessac. Inspired and accompanied by him, the JOSEPHINE party returned to Bordeaux; and Cabard walked out boldly to have a chat with the gate-keeper, from whom he discovered that the night patrols Forman had feared did not exist.⁴⁶ They 'obtained' a small lorry, in which the four of them set out late on 6 June; it broke down. Next night they tried again, on bicycles secured by Letac. They found their explosives where they had left them, hidden in bracken about a furlong from the target; and Varnier, in the dark, re-cut the detonators, which had been affected by damp. Forman managed to escalate the wall and to jump clear of the high tension wire; he then simply opened the main gates from inside. This was noisy, but provoked no reaction. The rest of the team joined him; within half an hour a three-and-a-half-pound plastic charge in a magnetic case, with an incendiary bomb attached, had been fitted to each of the eight main transformers, and the party left. Just as they got to their bicycles, all their charges went off; and they rode back to their digs by the light of burning oil and of searchlights hunting for the bomber the Germans supposed to have passed.

Six of the eight transformers were destroyed by these small but exactly sited charges; the charges must have slipped off the other two – all eight were very wet – before they exploded. All the spare special transformer oil in France was needed to effect repairs, which were not completed till early next year. Meanwhile, attempts to run the all-electric railways of south-western France from Dax power station alone had simply blown a lot of fuses, and steam trains had to be reintroduced to keep the lines going; while work in the Bordeaux submarine base and in numerous electrically-powered factories was held up for some weeks. The commune of Pessac was fined a million francs, and had a new curfew, from 9.30 to 5; on the other hand – an unexpected bonus – a dozen Germans were reported shot for having failed to patrol the power station efficiently.

The saboteurs missed a Lysander that called for them,⁴⁷ and set out for Spain at their leisure; they got through a quarter of a million francs (about £1,400) in two months,⁴⁸ and left a trail of broken glass if not of broken hearts behind them. Cabard was arrested just before they crossed the Pyrenees; he later escaped, and was working for SOE again by November.⁴⁹ The other three returned to England during August.⁵⁰ They had good reason to be pleased with themselves; they had provided an excellent example of the disproportionate value of a small force attacking a vital point. The effect of JOSEPHINE was even more marked in London than in south-west France; for it provided proof of SOE's capacity to inflict substantial damage on the enemy's economy, and the force's hitherto shaky reputation was enhanced accordingly.

F, RF, and EU/P sections and de Gaulle's *Service Action* each tried during the summer and autumn of 1941 to build up something fit to be called an organization in France. SAVANNA and JOSEPHINE between them were held to show that it was feasible to install agents in France, and build up semi-permanent groups of them on French soil round which reliable local elements could crystallise.

This basic and essential work was, of course, helped forward by the German invasion of Russia on 22 June 1941. Up to that day the British had stood almost alone – not quite alone, as they like to believe, for they had several exiled European governments beside them in England ready to encourage resistance, Greece as an active ally from October 1940, and the willing support overseas of the 'old dominions' as well as the acquiescence of India and the colonies; but the position had been far too lonely to be comfortable, or to inspire any hope of a swift British victory. Swift victory was still not in sight after, as the Marxists put it, 'the character of the war changed'; but at least the scales were more evenly balanced. Indeed, note needs to be taken of Boltin's claim: 'Without the heroic struggle, and without the victories, of the soviet people, Resistance could never have reached its final goal; for the Allied military victory over fascist Germany would itself certainly have been impossible without the contribution of the USSR.'⁵¹ Inside France, Russian

participation in the war had one important effect that derived from the strength of the French communist party. The small core of disciplined stalinists who ran this heterogeneous body had hitherto welcomed the German occupation forces, as allies of the Soviet Union, and now changed their attitude abruptly. In May 1941 *Humanité* had begun to call for a 'Front National' to embrace all French parties and assert a neutral position between Germany and England.⁵² After the German attack on the USSR drove them off neutrality, the communists turned this nascent organization onto an anti-German course. The Front National became a widespread and effective resistance movement; most of its supporters, who reached as far to the right as Louis Marin, were unaware of its inner leadership. All its guiding spirits were communists, who had control over parts of the French proletariat, clandestine experience, discipline, and gallantry enough to ensure that it rapidly began to make life difficult for German forces in the main industrial areas of Paris, Lyons, and the north-east through its military wing, the *Franco-tireurs et partisans* (FTP), named after the guerilla heroes of 1870–71.⁵³ The FTP later became formidable with the help of contacts in the countryside, in areas where the traditions of 1789 still favoured voting on the extreme left. The movement grew, indeed, so vigorously that its leaders sometimes reminded one well-informed observer of the sorcerer's apprentice, who unleashed forces far too strong for his own control.⁵⁴ But town and country groups alike were short of arms and explosives: this drove the communists into contact with SOE.

F, EU/P and DF sections had a very few agents already established in France, and RF – not counting the JOSEPHINE evaders – had several ready to leave, before ever the USSR was forced into the war; months before the FTP was born, and indeed while official French communist policy was still to denounce the British attempt to keep up the war against nazism as a capitalist plot motivated by imperialist ambition and greed for profit. Communists currently maintain that the character of a war changes from 'unjust' to 'just' when 'the masses participate whole-heartedly in it'; ill though it fits into the rest of their system of thinking, they cannot easily ignore the mass participation of the British from midsummer 1940. Mass participation by the French came later; inspired about equally by de Gaulle, by the communists, and by the British.

As this last opinion has been sharply contested, it is worth a few words' defence. Communists, as a matter of party duty, have claimed for years – evidence or no evidence – that French resistance was practically speaking a phenomenon of purely communist inspiration; a view which no sensible man outside a communist party can entertain. Gaullists, from party duty and from loyalty to their leader, incline to make claims for the general that are exaggerated almost as far. And a few important British authorities have stated their private conviction that without SOE, the RAF, and the BBC – above all, without SOE – though French resistance might have eked out a

hole-and-corner existence for years, it could never have grown and flourished as it did. In this historian's view, there is something approaching equal weight for each of the three claims.

What, in fact, had the operational branch of F section so far been doing? In its first tentative and groping efforts to come to grips with the enemy, it dispatched two dozen agents to France – all but two of them starting in the unoccupied zone, though several worked north of the demarcation line. Some worked alone, as far as they could; others in company with each other, or with sub-agents recruited in the field. As only four of them had wireless transmitters, and two of these four were only at large for a few days, most of them were handicapped by lack of rapid communication with their home base. The one woman agent among them set up an advanced F base at Lyons, but she had no wireless operator herself, and with the cover of a neutral journalist she could not easily pass round France anything more bulky than money or messages. By the end of the year a third of the agents were behind bars, most of the rest were in hiding, much reconnaissance had led to very little actual sabotage, and the section office at home had been convulsed by a dispute severe enough to shift the senior staff out of it. Still, 'time spent in reconnaissance is seldom wasted', and the effort had not been quite in vain. In this initial phase it seems worth specifying, man by man, just what was done and undone.

The section's staff and agents had fretted during the spring of 1941, anxious to start work but unable actually to get going; sea transport was frequently promised, but practically never in fact available. Twenty agents were ready by the late spring; they had all gone through Wanborough on the same course⁵⁵ – an injudicious arrangement at this early stage, since if one of them was captured and broke down he might endanger the rest. Even this score of men was lessened by a quarter when three agents about to leave were killed, and two more wounded, in an air raid early in May.⁵⁶ By then things had at last begun to happen.

Who was the first agent from the operations branch of F section to reach French soil? The question is straightforward; the answer is not. The war diary for March 1941 includes a laconic remark under a 'French section' heading: 'After a second failure to land the Brittany Agent, the operation was successfully carried out on the night of the 27th'.⁵⁷ (A previous failure to land 'agents' by sea for the same section on the 19th had been noted.⁵⁸) An undated postwar note of Thackthwaite's in an honours and awards file mentions that this agent was a gaullist one. Nothing else whatever seems to be recorded about him, not even his name or field name; and for lack of evidence about him we must assume either that he fell straight into enemy hands or that he joined some other service on arrival. This leaves us with the usually accepted character as the first man in – certainly he was the first man to be parachuted: Georges Bégué, alias *George Noble*, who was dropped blind on the night of 5/6 May 1941 into unoccupied central France, some

twenty miles north of Châteauroux, between the small towns of Valençay and Vatan.⁵⁹ On the fiftieth anniversary of this event, a memorial to 104 SOE dead, mainly from F section, was unveiled in Valençay; in the presence not only of the local prefect, but also of a minister from Paris, as well as Her Majesty Queen Elizabeth the Queen Mother – thus providing the first official French recognition of F section, against which de Gaulle had so often protested. The air force claimed Bégulé was dropped within a furlong of the chosen spot, but to his annoyance he found he was several miles beyond it.⁶⁰ He had a tiresomely long walk, for the rest of the night, carrying his transmitter in a suitcase with his clothes, and came at dawn to the country house of Max Hymans (*Frédéric*), a retired politician who was a friend of a French friend of Cadett's. Hymans had not been warned of Bégulé's coming, and was away; but they quickly met, and Hymans was happy to cooperate. He introduced Bégulé to a Châteauroux chemist called Renan and then to a local garage-keeper, Fleuret, who had the doubtful honour of being F section's first 'live letterboxes'; doubtful because in these early days SOE's agents had yet to learn the value of cut-outs and the overriding importance of security, and Fleuret's garage became a general rendezvous and bicycle park where they met to gossip.⁶¹

Bégulé reported Renan's address back to London promptly, on 9 May. Three more agents were dropped nearby at once, and equally briskly made contact with him: Pierre de Vomécourt (*Lucas*) and *Bernard* arrived on the night of the 10/11th and Roger Cottin (*Albert*) two nights after. *Bernard*'s contribution consisted solely of depositing some money for Bégulé at Renan's shop. He was denounced to the Vichy police by peasants who had seen him land, did not manage to make further contact with Bégulé or anyone else while under house arrest, and having a wife and child to look after contented himself with talking his way into the regime's good graces. In the end he became a civil servant under Vichy, going as slow as he dared in directing labour to Germany, though never in touch with the large civil servants' resistance movements. When eventually he returned to England after the liberation, he protested that he had never received any further orders.

Pierre de Vomécourt, his companion, was more combative. He was one of three brothers, barons of Lorrainer origin, landed gentry of the Limousin with strong views on the necessity of keeping up the fight against the Hun; a vigorous, talkative, good-looking man in his middle thirties, a good shot, a fast thinker, full of energy and enthusiasm. Indeed according to his brother Philippe (*Gauthier*), whom he promptly recruited, but for him F section would never have been founded at all.⁶² Such a Vomécourt-centred account of the section's origins is wide of the mark; but there is no doubt that Pierre de Vomécourt's early role was of essential importance. He did for F section's work in France what Gladstone once said Cobden did for free trade, and Parnell for home rule; 'set the argument on its legs', so that people could see what the real issues were and make up their minds how they should be tackled.

Encouraged by Pierre's news that they could have influential backing from London, the brothers divided France up informally into three sections. Pierre based himself on Paris, and toured widely round northern and north-western France, seeking out wherever he went the people who were already declaring in private their hostility to the nazis, and assessing their probable future worth to SOE. The best of them he proposed to incorporate in his stillborn circuit, AUTOGIRO. Jean the eldest, who had been badly wounded in the RFC in the previous war,⁶³ was living at Pontarlier; so he took charge of eastern France and set up several small effective circuits of resisters in place of the escape line he had been running into Switzerland. His organizing ability was marked, and his energies as unflagging as Pierre's; he was soon being trailed by the Gestapo. They caught up with him eventually, in August 1942, and sent him to a concentration camp where, in the end, he was murdered within sound of the Russian guns.⁶⁴ Philippe was to concentrate on France south of the Loire, and as an outward and visible sign of London's support Pierre arranged for him, through Bégue's wireless, the very first supply drop of warlike stores to be made to France. Two containers, the forerunners of nearly three score thousand, were dropped (at the fourth attempt) by a Whitley early on 13 June⁶⁵ close to Philippe de Vomécourt's château of Bas Soleil, ten miles east of Limoges. He and his gardener's son-in-law managed the reception between them, hid the stores in the shrubbery near the house, fended off the suspicions of the local police – one of the containers had hung up under the Whitley's wing, and the plane had been circling for an hour, attracting inevitable attention – and found themselves equipped with tommy guns, fighting knives, plastic explosive, and limpet mines with delay fuses for use against ships.⁶⁶ They were over a hundred miles from the sea; but to get stores of any kind from London, however inappropriate for the day's needs, was a further stiffener to the de Vomécourts' excellent morale. The Admiralty and the Ministry of Economic Warfare were already a good deal put out by the German blockade runners in Bordeaux, and someone would have to attend to them one day. Meanwhile, the home staff looked on the drop as a substantial achievement.

Bégue had had a lot of trouble arranging it with London, and the trouble brought danger; for the German wireless interception service had detected his transmissions almost at once, had begun to jam them within half a week, and had stirred the Vichy police into keeping a keen look-out for strangers all round Châteauroux. Direction-finding vans soon joined in the search. To keep down his transmission times was therefore indispensable for Bégue; and he proposed the use of the BBC to indicate whether and even when operations were to take place. From this proposal, derived the whole elaborate system of 'personal messages', already described,⁶⁷ that formed so conspicuous a part of resistance movements all over western Europe.

SOE's high command had next to decide, on the substantial evidence provided by these earliest moves, what its long-term policy towards French

resistance was to be; this decision formed part of a general survey of the European scene initiated, from outside SOE, by a FOPS paper of 12 June 1941.⁶⁸ This paper envisaged uprisings, 'attack[s] from within', in the distant future by 'a potential patriot mass' that needed 'organization and much propaganda preparation' before it was ready to rise; for France, like some other occupied countries, was still 'spiritually unready for revolt'. The joint planning staff was dubious, and passed the paper to SOE for comment; the result, six weeks later (21 July), was a long minute from Dalton to Churchill in which MEW claimed that SO 2 'can now, if so directed, set in motion large-scale and long-term schemes for revolution in Europe'.

Dalton envisaged a threefold aim: subversive propaganda, by SO2 agents with SO1's material; serious sabotage; and the building of secret armies. He proposed to assemble 3,000 Frenchmen in small sabotage groups by the autumn of 1942, and to have armed and ready by the same date a French secret army of 24,000; but to do this no less than 1,200 aircraft sorties would be required, at a comparatively mild scale of armament – each sabotage group of seven men was to have one tommy-gun; six pistols; a knife and two grenades a man; and 100 pounds of plastic, to last them for a year. No doubt a lot of careful work was done by Gubbins's staff in the M directorate while this document was being prepared; but there was really so little evidence on just this point to go on that they might as well simply have thought of a number, doubled it, and taken away the number they first thought of. At all events the paper provided a basis for argument. Naturally, Dalton stressed in it the need for a careful plan; the damaging explosions proposed must not degenerate into 'a succession of feeble reports, or a flicker and a splutter'. His paper was at once referred by the Prime Minister to the chiefs of staff, and by them to the joint planning staff; who reported on it, without enthusiasm, on 9 August. Sabotage, they agreed, was valuable against targets the air force could not reach, and local patriot forces would be essential in the closing stage of the war; but that was a long way ahead, and SOE should have more progress to report before it could receive much more assistance. At present it would be unsound to sacrifice bomber effort, or even sorties for intelligence purposes, to meet the claims of SO 2, which the joint planners clearly thought excessive.

The chiefs of staff considered this on the 14th, and expressed doubts whether arms and ammunition dropped into Europe would fall into the right hands; this might involve the RAF in a still more extensive flying programme. 'Some doubt was also expressed on the utility of secret armies held down by the ruthless German methods, backed by well equipped troops.' They put off the question of secret armies till next day, when the same team – Portal, Phillips, Pownall, and Ismay – discussed them, at the tail end of a meeting, with Jebb and Gubbins, Jebb hedged adroitly on the extent to which secret armies could be organized efficiently, and pressed the point that it was important to start right away with organizing them at all. Gubbins

backed him up with practical details about how the security of supply drops could be arranged. SOE got one immediate advantage out of these discussions: Portal promised at this chiefs of staff meeting to expand the special duties flight into a squadron, and this was done within a fortnight.⁶⁹

Meanwhile, at a much less exalted level, RF and F sections were going on with such work as they could. Late on 5 July 1941 RF's TORTURE dropped; this was meant simply to be a reconnaissance for another coup de main of the SAVANNA type. Two young Frenchmen, Labit and Cartigny – Labit the leader was only twenty – were dropped blind in western Normandy to investigate the chances of sabotage at the large German air base of Carpiquet by Caen. But they ran into difficulties soon after landing, initially over a very minor point: Bergé had forgotten to mention that trains no longer ran on Sundays in the occupied zone. Cartigny was arrested (he was later presumed shot), and Labit had to hide for some hours in a stream to avoid the same fate. Undismayed, he made his way to Toulouse, in the unoccupied zone, where contacts with Professor Bertaux in the university enabled him to get the beginnings of a circuit called FABULOUS under weigh.⁷⁰ A wireless operator dropped to FABULOUS, with a few stores, in September, and Forman (*Dok*) and another operator arrived in mid-October on an operation called MAINMAST.

This had a too portentous flavour. On the brave but politically inexperienced Forman there rested the responsibility of getting into contact with LIBERTÉ, an early resistance movement of catholic tendencies, and forming it into fourteen separate regional organizations covering the ZNO, each one divided into separate branches for secret armies, information, sabotage and propaganda; of making further contact with six resistance organizations in Paris and one in the Ardennes; of dividing these up in the same way; and of returning to London. This was expected to take about three months.⁷¹ Needless to say, he could carry hardly any of this over-ambitious programme through. He left Labit running training schools in underground warfare in the suburbs of Toulouse, with a wireless transmitter in the municipal baths, and moved to Montpellier where he saw Teitgen and de Menthon, LIBERTÉ's leading spirits. They were already in touch with another British service, and did not miss the chance to play one off against the other; and the whole movement smacked to Forman of the dry and narrow jostling for position that had been so dreary a feature of party life under the third republic.⁷² Forman in any case was far less qualified to impose a settlement between de Gaulle and the leaders of LIBERTÉ than was the emissary whom LIBERTÉ, LIBÉRATION and VÉRITÉ had jointly sent to London by a private channel through Lisbon; the formidable Jean Moulin, who reached London a week after Forman left it.⁷³ The Vichy police were hard on Forman's trail and on Labit's, and caught both their wireless operators late in the year; the two organizers fled to Paris for Christmas, and found it prudent to request return to England by the OVERCLOUD line.

OVERCLOUD was the achievement of Joel Letac, whom we met a few pages back on SAVANNA and JOSEPHINE. Barry and Piquet-Wicks were able to secure provisional agreement to an SOE circuit in Brittany nourished from the sea; and in the small hours of 15 October 1941 Letac (*Joe*) and his even younger wireless operator the Comte de Kergorlay (*Joew*) rowed ashore in weather that Holdsworth called 'the reasonable limit of MV 360's operational endurance'.⁷⁴ They landed near where Letac spent his holidays, on a wild strip of coast at the north-westernmost tip of France, between the Aberwrac'h and the Aber Benoit. He again enlisted the help of his brother Yves, and of his mother. He made contact with a Breton railwaymen's organization called LA BÊTE NOIRE and with a sizeable group of university students at Rennes, but otherwise his achievements were small; partly because de Kergorlay had little competence in cipher and less in operating his set.⁷⁵ The nearness of the circuit to England made it almost inevitable that some use should be made of it for bringing agents out from France. Piquet-Wicks has described in life-like detail the sea operation that sent the Corsican Scamaroni northward across the Channel on the last night of 1941; though for sentimental reasons he dates it a week early.⁷⁶ Forman, Labit, and both the Letac brothers, with several others, came across to England in the same MGB. There we must leave them for the moment, in better heart than most of the gaullists' other *action* expeditions of the year.

These had included one other coup de main party, BARTER, mounted at last against the Mérignac airfield on 11 September. Two officers were dropped near Mimizan to reconnoitre the target, prepare a detailed plan for the attack, and wireless back particulars for the sending in of an assault party; but their transmitter was damaged in landing and for the time being they vanished. Another project, to launch resistance in Vichy itself, also came to an abrupt end. An electrical engineer called Lencement made his own way to England through Spain in the first half of a month's holiday, arriving on 12 August; he was dropped back near Vichy, without a moon to help him, on the night of the 29/30th (TROMBONE) with instructions to form three circuits among his neighbours for sabotage, propaganda, and intelligence. But of course there had been no time to brief him properly; the police closed in on him, and he was in prison before the year was out. (He was released in 1942, re-arrested in 1943, and sent through Fresnes to Buchenwald and Dora; from which he had the good fortune to return.)

Two other early gaullist attempts to gain contact with the resistance that undoubtedly did exist in France were more successful. DASTARD went in, fifty miles south-east of Paris, on the night of 7/8 September; this consisted of a Parisian left-winger, Laverdet, and a wireless operator. They made contact with a sizeable resistance group named the 'Armée Gaulliste Volontaire' which claimed as many as 60,000 members, most of them civil servants; but the Gestapo promptly detected the transmitter, and DASTARD spent Christmas on the run at Auxerre.⁷⁷

OUTCLASS was more fortunate; perhaps because he worked alone. He was the young Yvon Morandat, one of the least conspicuous and most effective Frenchmen engaged in resistance work. He was dropped near Lyons on 6/7 November, with the civil mission of making contact with the Christian trade unionists there; this he soon accomplished. Looking round him, he saw plenty of resistance work he might do, and stayed in France to do it: we shall meet him again, for Piquet-Wicks has justly described him as one of de Gaulle's finest political agents.⁷⁸ He was sent, in fact, by de Gaulle's commissariat of the interior, and Dewavrin for a time regarded him as a rival; he turned out as sound a patriot as he was a gaullist.⁷⁹

Another party, called COD, was less formidable; it consisted of a subaltern and a corporal-major, Thomé and Piet, who parachuted into central France two nights after Pearl Harbour (8/9 December). They were to take over part of an existing French intelligence *réseau*⁸⁰ which arranged their reception. They set up a small, discreet sabotage circuit at St Etienne: so discreet that for the time being it effected no sabotage. But at least it existed; Piet's wireless worked; and RF at the turn of the year was in a mood to count small blessings.

So was F. F's late summer and autumn were dogged by troubles over wireless. It was some months before Bégue's BBC message system was running smoothly,⁸¹ and such agents as there were in France had to make do with communications so inadequate that they endangered themselves and each other by over-using the few channels they had. Cottin for example, a director of Roger et Gallet the French scent-makers, bombarded Renan's shop with postcards for 'M. Georges' in which he gave Playfair-coded reports of his efforts to set himself up as a commercial traveller in soap in south Brittany. Arrangements for him to communicate through a courier in Paris broke down; but in Paris he met Pierre de Vomécourt, whose more powerful personality attracted him away from the creation of his own circuit and swept him into AUTOGIRO as de Vomécourt's second-in-command.

Much the same happened eventually to N. F. R. Burdeyron (*Gaston*), who was paired with a more rugged Frenchman, *Xavier*, as his wireless operator.⁸² Several fruitless attempts were made to put them into France by sea; in the end they were parachuted east of Avranches on 9 July 1941, to set up a circuit in western Normandy. Unluckily for *Xavier*, he was recognised a day or two after he landed by a local constable and put back in jail to serve out a long sentence for rape from which he had escaped when the Germans overran his prison a year before. Burdeyron was thus cut off from his military base; so he retired on his personal one, and rejoined his wife at Deauville. From there he did some quiet and useful work.

More successful than Labit, he made a two-day reconnaissance of the Carpiquet air base by the classic device of changing clothes with a friendly labourer there – an unexpected role for the second head waiter at the Dorchester, his previous post. He could do nothing against the airfield by

himself; but through Pierre de Vomécourt, whom he had known at Wanborough and ran into by accident in Caen, he told London what he had found out. His other success this autumn was to persuade some friends at Lisieux to indulge in minor sabotage in the factory they worked in, which made breech-blocks for naval guns. This was small beer, but it was something, and de Vomécourt made a note of his address.

Two more agents went into Vichy France with the August moon, on the 6th; both were influential, though in opposite directions. G. C. G. Turck (*Christophe*), a French architect who had been the French deuxième bureau's liaison officer with section D,⁸³ left the aircraft late and clumsily, dropped into a quarry, and was knocked out; the police picked him up next morning, still unconscious. When he came round, he spun a thin cover story about having bribed an RAF pilot to drop him over France, as he disliked the English and wanted to get back; whatever the police believed, they let him go, and he soon regained contact with his companion, Jacques Vaillant de Guélis.

Turck, like Cassius, had 'a lean and hungry look'; Philippe de Vomécourt mistrusted him at sight, and was not the only one to do so; a woman neighbour near Marseilles 'had no confidence whatsoever in him'.⁸⁴ De Guélis on the other hand was a charmer: a thirty-four-year-old advertising agent, whose father was French and mother English, with an expressive, mobile face that was inconspicuous unless he happened to be wearing his handlebar moustache. He had been Gort's interpreter with the BEF in 1940, had been taken prisoner, and had made an adventurous escape to England with André Simon the younger; General Brooke, who had known them both in France, offered them to Gubbins direct. F section took de Guélis on originally as a briefing officer, and he made the first staff reconnaissance in France. Sporborg had minuted to Nelson 'that as a general principle it was right to refuse to allow members of headquarters staff to go into the field on any pretext, but he felt that de Guélis's special qualifications and the unusual circumstances of the present case made it a suitable instance for an exception'.⁸⁵ Keenly interested in French politics, brave, adroit, and energetic, de Guélis did a great deal of useful work during his month's stay. Besides numerous minor missions, such as the collection of specimen ration cards and demobilisation papers, he carried out three main tasks.⁸⁶ Of one, reconnaissance round the mouths of the Rhône for suitable spots for clandestine landings, nothing came; the others were more fruitful. The original main object had been for him to bring half-a-dozen particularly promising recruits back with him by submarine; this had to be given up while he was still in England.⁸⁷ As it turned out he recruited several remarkable agents on the spot, and gave them addresses through which they might communicate with London: among others, Dr Lévy of Antibes, Philippe Liewer⁸⁸ (better known as Staunton), Francis Garel, and Robert Lyon, all of whom will appear later. Thirdly, and as it turned out most useful of all, he prepared the way for the first resident woman agent SOE put into France, the indomitable Virginia Hall (*Marie*).

She was a thirty-five-year-old journalist from Baltimore, conspicuous by reddish hair, a strong American accent, an artificial foot, and an imper-turbable temper; she took risks often but intelligently, and in her first spell of fourteen months' activity in France was never once arrested nor more than superficially questioned.⁸⁹ True, this was partly because she began her residence in Vichy and Lyons by establishing reliable contacts with the local gendarmerie, with whom she registered when she arrived – quite openly, from Iberia, as an accredited correspondent of the *New York Post* – at the end of August. She soon established herself in a flat in Lyons which became a base for F section's agents in unoccupied France; nearly all of them who were in southern France before the Germans came passed through it sooner or later. She did not herself have the relief and the excitement of indulging in sabotage; she undertook instead the more exacting tasks of being available, arranging contacts, recommending whom to bribe or where to hide, soothing the jagged nerves of agents on the run, and supervising the distribution of wireless sets. This was quite as dangerous as actual sabotage, and much duller; but without her indispensable work about half of F section's early operations in France could never have been carried out at all.

De Guélis had arranged Virginia Hall's original contacts in Lyons for her; then he passed his Camargue fisherman acquaintances on to Turck, and hurried back to Châteauroux to catch his aeroplane home – bearing in his head, unluckily, the addresses of some points of contact Turck had made at Marseilles, including the Villa des Bois. Bégué was already feeling the breath of the police hot on his neck, but managed to make all the necessary arrangements with London for SOE's first Lysander pick-up. De Guélis had to conduct the reception by himself; and nearly failed to turn up at all. Just as he was getting ready to leave his hotel after dinner on 4 September to cycle out at leisure to the chosen field,⁹⁰ the local gendarmerie chose to arrive for a routine but maddeningly slow check of everybody's identity papers. By the time this was over de Guélis, who had concealed his impatience as best he could, had to put in some furious pedalling; as it was, he could already hear the aircraft when he got near the ground. Jumping off his bicycle and through the nearest gate, he laid the lights out quickly – on the wrong field. Nesbitt-Dufort, commander of the newly formed Lysander flight of 138 Squadron, put his aircraft down without trouble, but fouled an electric cable on taking off, and returned to Tangmere with several feet of copper wire wound round his undercarriage.

The Lysander had brought over Jerry Morel, an insurance broker trilingual in English, French and Portuguese, who had time to collect two bottles of champagne and one of scent forgotten on the ground by the hurried de Guélis,⁹¹ before discreetly fading into the countryside as a gendarme cycled up to find out what the noise had been about. Morel's mission may be disposed of parenthetically: it was less of a success than had been hoped. His task was to contact numerous friends and encourage them to form groups that

would carry out sabotage later if the British armed them, or at least to finance other people's groups working for the same end. He made a fair start; but after six weeks one of his contacts betrayed him, and the French police arrested him.⁹² He found himself sharing a cell in Périgueux jail with Langelaan, of whom more shortly; before his case came to trial he made himself fall seriously ill.⁹³ He was moved to Limoges prison hospital, where in mid-January 1942 he had a major abdominal operation. The night after they took his stitches out, while the policeman at his bedside dozed he slipped out of doors on the arm of a nurse, who helped him over the wall; a friend of Philippe de Vomécourt's was waiting for him outside with some clothes, and Morel staggered through a snowstorm for the rest of the night, until he got to Bas Soleil in daylight. The de Vomécourts passed him on to Virginia Hall, who saw him on to a line across the Pyrenees;⁹⁴ and by the end of March 1943 he was working as F's operations officer, a post he held until midsummer 1944.

Let us return to the main stream of F agents; which was swollen, two nights after Morel's arrival, by the largest drop of men SOE made into France for eighteen months. Six agents went down south of Châteauroux on 6/7 September: Ben Cowburn, a tough Lancashire oil technician; Michael Trotobas, later the hero of resistance at Lille; Victor Gerson, an inconspicuous merchant; George Langelaan, formerly of the *New York Times*: the Comte du Puy; and, for the moment most important, Georges Bloch (*Draftsman*), a wireless operator with his set. Bégué, Hymans, and the nearest farmer, Octave Chantraine, received them.⁹⁵ Bloch, like Cottin, was promptly annexed by Pierre de Vomécourt, settled in the occupied zone – first in the suburbs of Paris, then at Le Mans – and kept busy transmitting his organizer's far too lengthy messages, and any others that his colleagues managed to place in his hands. Cowburn set off on a circuit of oil targets all over France, finding out which were working for the Germans and planning future attacks; this indicated a fairly prompt response by SOE to an important strategic requirement. Hankey and Lloyd had long been pressing on the British high command the vulnerability of Germany through her oil supplies; but the RAF had discovered during this summer that oil plants were targets too small for its bomber crews to hit. SOE had to take over where bomber command left off.⁹⁶ SOE's response, though prompt, was equally ineffective; Cowburn produced plenty of useful information, and oil targets were prominent for years in agents' briefings, but few important ones were even damaged; they were too well guarded. According to Brooks Richards, he did destroy one at least on his first mission, as he had helped to build it before the war and therefore knew his way about the site thoroughly. However, he said in his own book, 'I had been unable to blow up any of my targets.'⁹⁷

The rest of the party re-acclimatised themselves slowly; du Puy at his own home. Langelaan, engaged in a propaganda mission, did manage to

see the aged Herriot, in whom he found ‘no desire to get away and come to us’;⁹⁸ he was the first of a swarm of visitors who descended on the old man, each claiming to be the only authentic allied representative and none knowing anything of the others – none, consequently, was warmly received.⁹⁹ While waiting to meet Bégué in a restaurant at Châteauroux and report this meeting home, Langelaan was picked up by the French police exactly a month after landing (5 October). He thus paid with his freedom for his categorical refusal during training to learn to work a transmitter himself. His arrest marked the beginning of the dark age for F section; but before other arrests can be described, eight more arrivals need to be noticed.

They came in two parties of four. Basin (*Olive*), Leroy,¹⁰⁰ Roche, and Duboudin were landed from *Fidelity* on 19 September on the beach at Barcarès, north-cast of Perpignan. Bodington flew out to Gibraltar to give them some last minute instructions; he found them ‘on the top of their form’¹⁰¹ after a harrowing seventeen-day voyage through U-boats and equinoctial gales, and they went their various ways ashore at once: Basin to the Riviera, Leroy to Bordeaux, Duboudin to Lyons, and Roche to Marseilles and prison.¹⁰² The CORSICAN mission – J. B. Haycs, Jumeau, Le Harivel, and Turberville – arrived by parachute on 10/11 October to a reception near Bergerac arranged by Pierre Bloch (*Gabriel*),¹⁰³ a former socialist senator recruited by de Guélis. They were all four trained sabotage instructors (Le Harivel was also a wireless operator); and they were all in prison before ten days were out. Turberville dropped wide of the others, but with all their containers; he was arrested by the gendarmerie next morning, and the others fell successively into a Vichy police trap when trying to make contact with Turck at the Villa des Bois, or at other compromising addresses in Marseilles. The same trap, manned by someone who resembled Turck closely enough in voice and figure to deceive several agents, also caught Robert Lyon, Roche, Pierre Bloch, and – last and worst of all, on 24 October – Georges Bégué. On one of these captured agents Fleuret’s name was found, and Fleuret was arrested too; Garel was caught at his garage, and Trotobas also was pulled in at Châteauroux; Liewer was arrested soon after at Antibes on account of an indiscretion of Langelaan’s. The result in fact of giving those Marseilles addresses to so many incoming agents had been that five of them had been arrested at them; these arrests had led the police to a sixth newcomer, to several of SOE’s new French friends, and to the almost indispensable Bégué. Turberville escaped some weeks later, by jumping off a train while being transferred from one prison to another; lay low in an Auvergnat village; and finally got back to England in 1943. The rest were longer behind bars, though most of them managed a faster return journey.

This run of arrests might well be called unfortunate. F section had good reason to trust de Guélis, who after all was on its own staff, and there was really nothing but his unfortunate face against Turck; moreover Virginia Hall’s contact address – a bar she often visited in Lyons¹⁰⁴ – was also widely

known, without any resulting harm. But there is no satisfactory excuse for a failure of this kind: it was simply defeat. Long afterwards, when he came back from Germany, Turck explained that he had heard from a Vichy army friend in Lyons that the police were after him; he disappeared immediately, leaving no address. He went to ground at his fiancée's in Paris; as the hunt did not seem to be up, he emerged from hiding into clandestine activity, and the two of them organized an ostensibly innocent road transport service between Paris and Marseilles, which Pierre de Vomécourt financed with money dropped from London, without bothering to report the fact. Turck survived de Vomécourt's disaster; but a too casual meeting at St Germain des Prés led him in the end, in July 1942, into the arms of the Gestapo. There he showed heroism, eventually rewarded with an MC. He said nothing under torture in Paris; tried to protect a Senegalese soldier from a beating-up at the Compiègne transit camp, for which he was beaten up again himself and kept stark naked and starving for three days in an empty cattle-truck in several degrees of frost; and ended up at Buchenwald and Dora, which he endured for over fifteen months.

The arrests at the Villa des Bois and elsewhere only left at work for F in Vichy France Virginia Hall; Basin and Lévy who were cooperating at Antibes in an embryo circuit called URCHIN; Jean Bardanne a well-known Marseilles journalist, who tried to negotiate the release of agents caught at the Villa till sheer weight of numbers ran him out of money and he was arrested himself; Duboudin, struggling to form sabotage teams around Lyons; and the ever-active de Vomécourts. Gerson, who had arrived with Cowburn on 6 September, was prudent enough to escape the Marseilles *souricière*¹⁰⁵ though invited like the rest by telephone to enter it. More by flair than by reasoning, he decided he did not like the Villa; discreet inquiries in circles likely to be well informed did not reassure him; so he simply faded out of sight. By the end of the year he was in Spain. He will reappear later.

In the occupied zone meanwhile there were fewer arrests; fewer agents were there to be arrested, Leroy was alone in Bordeaux. He took his task of reconnaissance seriously, and was working as a dock labourer in order to learn his way about. Cowburn discovered a convenient way of crossing the demarcation line, under the tender of a railway engine with a friendly crew;¹⁰⁶ he spent more time than he felt safe in Paris with the other F agents in the north,¹⁰⁷ and was gradually drawn into the whirling vortex of AUTO-GIRO. He helped Bloch arrange a small supply drop in the Sarthe in October,¹⁰⁸ which provided Pierre de Vomécourt with the beginnings of a collection of sabotage stores; but Bloch's days were numbered. The Gestapo's direction-finders were closing in on him; he transmitted too long at a time and too often from the same place in Le Mans. The last message was received from him on 12 November; he is believed to have been arrested next day by the Germans, and to have been shot by them – without trial – in Paris three months later.

This left AUTOGIRO, and everybody else, with no quick means of passing messages to London at all; the quickest remaining, through a neutral legation at Vichy, took several days at least, and Vichy was the last town where any agent wanted to hang about waiting for a message. Pierre de Vomécourt was too impetuous a man to wait, in failing weather, for another operator to be dropped – there were in any case no drops either of agents or of stores for F section by the November or December moons: the hard early winter that was chilling the Wehrmacht's heart in Russia was severe in the west as well. By now he could call on the services of something like 10,000 resisters, if only he could get prompt contact with SOE and so get arms and orders for them.¹⁰⁹ He knew there must be other wireless operators in touch with London, though not with SOE; and he set out to find one.

French security being what it was, he succeeded after about a month. At a little café on the Champs Elysées, on Boxing Day, through her lawyer Michel Brault (*Miklos*), he met a vivacious Frenchwoman of about his own age, Mathilde Carré, who proclaimed herself already an ardent résistante and claimed to be the mistress of the head of a Polish intelligence *réseau* called INTERALLIE.¹¹⁰ Could she pass a message to London for him? Certainly, she could. So he encoded one containing pre-arranged catchwords that would assure SOE it genuinely came from him; and shortly received a reply containing catchwords that assured him it really came from SOE. Several more messages passed at once by the same channel. He did not then know that *Victoire*, as Mme Carré was called in SOE, had been living for some six weeks with a sergeant in the Abwehr who read and reported all the messages that passed through her hands, and on information supplied by her had arrested most of her colleagues.

For the time we must leave him, poised on the brink of that treacherous abyss,¹¹¹ while to complete the tale for 1941 we glance at the affairs of some relevant Spaniards and Poles. The Spaniards can soon be put aside. There was a potentially formidable body of republican refugees organized by an English left-winger caller G. N. Marshall, scattered over most of western France on both sides of the demarcation line, already running some useful lines from Perpignan to Barcelona, and preparing elaborate plans to blow up railways in the ZO. But nothing whatever came of the plans, since negotiations with so many republican Spaniards were held by the Madrid embassy to imperil British relations with Franco; Marshall and his family were discredited; and the Spaniards were thrown back on their own devices.¹¹² A few of them eventually found their way to north Africa, and were used by SOE on various menial tasks. Individually, some of them who stayed in France did extremely well; so well that the loss of their services as an organized body must be marked down as an early failure, imposed on SOE by the Foreign Office.

Lastly, the Poles. In the summer there were plans to put half a dozen agents in during July, two or three of them by sea (MOUNTEBANK),¹¹³ only one in fact got to France, in an operation called ADJUDICATE that was thoroughly

Polish in flavour. Count Dzieżgowski, the single agent involved, took his own transmitter with him; but had such bad luck getting away from England that he had put in twenty-eight hours' flying over occupied territory before he managed to drop, blind in south-west France, on 2/3 September. He fell into trees and was so badly hurt that he had to spend some days in hospital before he could begin his mission.¹¹⁴ This was to hunt up as many as he could of the 4,000 Polish troops in the ZNO, 'to lay among them the foundations of an active sabotage organization and to investigate the possibility of later forming a secret military force'.¹¹⁵ His instructions had been carefully framed by the Polish ministry of the interior to hedge his activities in as tightly as possible; and for much of the six months he spent in France he was engaged in simultaneous disputes by wireless with them and with the Polish general staff's deuxième bureau, which had selected him for the job. From a welter of conflicting evidence a few points emerge about him: he was brave and energetic as well as garrulous and headstrong; he did manage to recruit eighty-seven Polish soldiers into small sabotage teams; and he did receive a few stores for them by air. There is no indication that they did much sabotage.¹¹⁶

Yet in those early days, who did? The Foreign Office still wished to be consulted before coups of any size were even planned, and was not quick to give leave for them.¹¹⁷ The utmost that F section could claim consisted of Burdeyron's go-slow friends at Lisieux; a couple of trains wrecked and some turntables broken at Le Mans through Pierre de Vomécourt; one whole Somua machine tool factory in Paris working at two-thirds speed through the same agency, a definite gain; some coal mines under-producing by the influence of his brother Jean; and a substantial number of trains carrying German goods delayed through the mis-directions of his brother Philippe.¹¹⁸ (Philippe de Vomécourt happened to have taken a post as a railway inspector, and enjoyed causing a substantial degree of dislocation in enemy traffic.¹¹⁹) RF could claim even less, Pessac apart; bodies like LA BÊTE NOIRE worked practically independently of it, and the few gaullist organizers in the field were so far training for future operations, not making present bangs. EU/P's small parties were more cautious still. Beyond SOE's range of contact there was already much talk, but little action, except by the communists. Their early efforts in France seem to have been devoted mainly to assassinating uniformed members of the Wehrmacht; presumably as a demonstration of combativeness intended to rouse the population to a frenzy of anti-German revolutionary fervour, thus precipitating a communist seizure of power. This was an expensive and impractical policy, and its most palpable result was to expose the French people to severe reprisals.

Yet reprisals could help resistance even more than hinder it. Many people date the origin of proper, nation-wide resistance in France to October 1941, when forty-eight citizens of Nantes were shot in revenge for one assassinated German colonel. For every Frenchman or Frenchwoman that reprisal executions of this kind frightened into acquiescence, a score were shocked into

opposition – in their hearts at least – and so became ripe for recruiting. This opposition transcended class barriers of every kind. To take a few random examples from within the SOE sphere, Mme de Caraman Chimay, enthusiastic when Morel sounded her out on her estate in the Dordogne, was a princess of the ancient aristocracy; de Gaulle himself was of an impeccable upper-middle-class family, a don's son and a regular soldier; Dewavrin, also a regular, after the war became a merchant (unlike his namesakes, he did not belong to the *deux cent familles*, though most files about him in London began by saying that he did); Gerson was a textile manufacturer, Deligant a merchant, Bégué a salesman, Bergé another regular, Teitgen a professor; Letac and de Kergorlay, students working with railwaymen; the de Vomécourts were gentlemen, Burdeyron was a gentleman's gentleman, Bloch was a left-wing politician, Leroy was a seaman. Every class in France in fact was represented in *la résistance*, which the French still like – in the teeth of the evidence – to regard as a single movement; just as every class in France contained its proportion of *collaborateurs*. There is nothing in the theory that only the communists and the priests 'really' resisted, any more than there is in the theory that all business men 'really' collaborated.¹²⁰

Still, the best hopes lay with the biggest battalions; and it is a fair criticism of SOE – as of de Gaulle's organization – that each was slow to get in touch with French organized labour. SOE's first formal attempt to make contact with a French working class leader, an opening move that came to nothing, deserves notice here; for this also belongs, in time, to the autumn of 1941. The leader was Léon Jouhaux, a great name on the French left since 1909 when he had become secretary of the CGT; holding that post ever since, he had played a central part in the international labour movement as well. Dalton insisted that an approach be made to him: this was the solitary point at which the minister's personal creed made any impression on SOE, in which few of the staff could have distinguished a revolutionary syndicalist from a company union boss, let alone the CGT from the CGTU or the CFTC. In the event, the impression was slight; for before arrangements for getting into direct touch with Jouhaux had been completed – this took months¹²¹ – Vichy had arrested him, and he spent most of the rest of the war in confinement.

This Jouhaux incident brought to boiling point, late in the autumn, an office row: a quarrel that had been simmering for some weeks between F section staff and the newly appointed D/R, for whose existence the section staff saw no need. Marriott had been cool towards the Jouhaux project, which the Minister was red-hot on pushing through; he may have been one of the targets of an angry minute of Dalton's about 'underlings playing reactionary politics'. A good deal of manoeuvring resulted in a resignation, made by Marriott in the false belief that he was indispensable; Sporborg had to tell him he was not. Nelson laid down that a successor had to be found within SOE. Humphreys found himself disqualified by his previous

supersession. Buckmaster was chosen, over the head of Cadett – who also shortly resigned¹²² – and set about communicating his boundless enthusiasm to as many colleagues and agents as he could. He had useful and extensive contacts in France, and knew the country well. He was a colourful and in many ways a controversial figure; he had considerable gifts of leadership, and some of his most successful agents long admired him. Others did not; he was by no means universally popular, but no better head for the section was ever in sight.¹²³

An important decision was made by Gubbins about this time; in future, F section would try to send their agents to France in parties of three, an organizer to command, a whole-time wireless operator who would do nothing but work his set and maintain his cover, and an assistant who ‘would be responsible for the material side (e.g., ensuring the arrival of the proper utensils at the right spot and time)’ and would be the circuit sabotage expert and instructor.¹²⁴ In retrospect, this seems sensible; for lack of experience, it had not been done from the start.

The opening pawn moves had now been completed; some powerful pieces were already in play – Morandat, Miss Hall, the pinned Pierre de Vomécourt – and so were two pawns that would be promoted later, Gerson and Trotobas. With the new year, development began of a piece as powerful as the queen at chess: Jean Moulin.

VIII

Development: 1942

Jean Moulin's importance was threefold: it derived from who he was, who he had been, and who he was going to be. He was a man of fearless integrity, physically stocky and inconspicuous, yet with so commanding a presence and such gifts of drive and leadership that men would follow him far. Moreover he was a man on whom authority sat easily; for at forty-one he had been the youngest prefect in France at the time of the collapse. When it came, he stayed in Chartres to guide the fortunes of his department till Vichy dismissed him late in 1940 for not being pliant enough. He had no reason to love the Germans: they had thrashed him without mercy in June for refusing to sign an allegation of French atrocities he knew to be false. He had earned their grudging respect by trying to kill himself, sooner than be beaten up again;¹ they had done nothing to earn his. He had retired after his dismissal to a hamlet near Avignon, and had systematically built up two false personalities for himself while he sounded out such resistance leaders as he could find in the Rhône valley. As early as April 1941 he was in indirect touch with SO2, through the United States consul in Marseilles;² he left France on 9 September for Lisbon and London under his own steam, using one of his own false names, as the accredited representative of three new French movements, LIBERTÉ, LIBÉRATION NATIONALE, and LIBÉRATION. He described these bodies as 'the main organizations of resistance to the invader', and brought a message from them to the British and the Free French: that the French will to resist had already reached a point at which arms and cohesion could be usefully applied; to assist the nazis' downfall when the time came, and to preserve civilised society – this was clearly a prefect's point – at the stage of transition from a German-dominated regime to a free one. Only the communists could hope to benefit, he said, if the modest demands he brought with him, for money, communications, arms, and above all moral support, were not met.³

He made an excellent impression on his first direct SOE contact, in Lisbon; and continued to make it on everyone he met. He saw both Buckmaster and Dewavrin, as well as de Gaulle, and decided – he was the sort of man to decide such questions for himself – that he would work with RF section and the general;⁴ this brings us to the third important thing about him, who he was to be. De Gaulle also was deeply impressed by him, and he was the first figure of any political standing to come out of France and join the Free French. The hasty reader might conclude from the knowledge that de Gaulle and Moulin was each the son of a professor that they were brought up with similar academic backgrounds; but would be wrong. De Gaulle's father, though not himself in orders, had a chair of philosophy and literature in a Jesuit college in Paris; Moulin's was headmaster of a secondary school – therefore called *professeur* – at Béziers near the Mediterranean coast. De Gaulle's upbringing was strict, Moulin's was relaxed. Moreover Moulin's father brought him up on the firm if unspoken rule of French radicals and socialists, 'never have an enemy to your left'. This is quite enough to account for the comparatively friendly eye that Moulin cast, in the course of the underground struggle, on the communist-dominated Front National and its military wing, the FTP. When Moulin went back on the first night of 1942 he bore with him a warm personal message from de Gaulle to the resistance leaders he was to see, and some microphotographed instructions from Dewavrin.⁵ He bore also the title of delegate-general: delegated by the Free French committee in London, to control and coordinate all of their supporters in France. This appointment was held essential by the Free French. From it, in the end, there stemmed directly the tragedy of Caluire.⁶

According to his *ordre de mission*, which was signed by de Gaulle himself on 4 November 1941, his principal task was to extricate the serious workers from the mere talkers in the sound resistance movements and get them sequestered into wholly separate cells (*cellules*), each numbering about seven men. Each cell should have a leader and a deputy leader; no cell should know its neighbour; only the leader should know the next higher contact up the chain of command; the highest direction and the general problems of coordination would all be handled in London. The cells' primary duty was to *exist*: to be the nucleus of a secret army that should rise when the allies came. Meanwhile, liaison agents were to be sent to London to discuss the command structure – and presumably also to discuss arming the cells, though this point was only vaguely covered in the orders. Pending an allied invasion, sabotage and assassination were envisaged as probable future tasks; so, ultimately, was 'the use of military forces to take over the civil power', on 'the personal order of General de Gaulle'.⁷

That the general signed these orders at all represented a substantial triumph for Moulin, and shows how persuasively he could argue down high opposition; for less than a week before Dewavrin had told Piquet-Wicks 'that even General de G. was inclined to favour propaganda to the exclusion of

action, and in fact that the General appeared to have little faith in the possibilities either of a secret army or of effective work by para-military forces'.⁸ That the orders were signed nearly two months before anything could be done to implement them was just another example of how intricate the arrangements for clandestine operations were, and how much they depended on the weather. Moulin was to have dropped by the November moon to one of Forman's receptions; then by the December moon to the same; bad weather, lack of aircraft, and weak liaison washed both schemes out. In the end he went down blind, with two companions, on 1/2 January; the pilot claimed 'exact pin-point located without difficulty', but they found themselves ten miles from it, in a marsh east of Arles.⁹

Moulin, known in France as *Max*, carried in SOE the appropriate field name of *Rex* for it was he more than any other man – even than de Gaulle himself – who welded the antagonistic fragments of resistance in France into one more or less coherent and disciplined body: the unifying of resistance has been described by the leading authority as Jean Moulin's work above all.¹⁰ There will be more to say later about his adventures and achievements; the tour of duty we have just seen him embarked on lasted for nearly fourteen months before a Lysander brought him over to England for a few weeks' rest. His steady, relentless pursuit of the serious organization of resistance went on all through those perilous months and brought its reward. As early as 30 March he was able to report to London the completely gaullist allegiance of all the resistance movements he had so far encountered.¹¹

While this tunnelling work was going forward far under ground, sapping at the inner foundations of German occupation of France by crumbling away French acquiescence in defeat, skirmishing parties were at work as well against the outer battlements of *Festung Europa*. SOE had at first proposed mounting many of these parties;¹² and Dalton had expressed himself as 'all for them, when we are ready – and I hope this may be soon –' late in 1940.¹³ An informal arrangement made then between SOE and Combined Operations Headquarters proposed that SOE would handle small raids, say up to thirty men, and all raids far behind the coastline (using nationals of the country concerned, as far as possible, to make escape more easy), while COHQ would handle the rest.¹⁴ As it turned out, coastal raids of all sizes were much more readily mounted by COHQ and SOE mounted none of its own in France at all. However, much of COHQ's work needed SOE's help. Cooperation between the two bodies was close, and in 1942 was fruitful; stemming from an unexpectedly friendly hour's interview on 9 January between Mountbatten and Dalton, who found themselves agreeing 'that it was the French industrial working class on whom we must count'.¹⁵

There was inevitably some jealousy and tension between the two staffs, whose strategic roles were sometimes close together, whose needs and methods overlapped, who competed with each other for staff, for fighting men, and for fields of operation; but each soon learned to respect and even (rather

against the grain) to admire the other's capacity; and each was dependent on the other for a few facilities it could not secure itself. Much of such friction as was generated stemmed from an insistence on security precautions by SOE that sometimes appeared schoolboyish to CCO's officers, who did not see why (for example) CD's officers found it necessary to use one surname in Baker Street and another in Whitehall. But these were trumpery details: the basis for cooperation was sound.

SOE's main contribution to combined operations was technical. It provided for instance notes on 'the kind of minor damage which might be wrought by forces who have time on their hands', to be used in the training of commandos.¹⁶ Its research and devices sections were far ahead of anyone else's, for the special purposes of raiding techniques, and commando parties were often equipped with snowshoes, silenced weapons, delay fuses, and so on of SOE's design. Commanders of such bodies as the Special Service Brigade, the Small Boat Squadron, the early Royal Marine Commandos, and the first parachute units often visited SOE's research stations to be shown what was being done there, and placed large orders for special equipment and stores.¹⁷ For some important raids on France SOE provided the explosives and helped to train the men who were going to lay them. One of these, FRANKTON, has been noticed already;¹⁸ an attack on shipping at Bordeaux docks by a dozen marines in canoes, armed with SOE's limpet mines (12 December 1942). BITING, the parachute raid on the Bruneval radar station on 27/28 February 1942, was equipped by SOE with 'a number of special stores and tools which were essential for the unusual type of operation', and accompanied by a Sudeten German on SOE's strength who was prepared to confuse the enemy by shouting orders and counter-orders in the dark.¹⁹ As it turned out, his services were not needed. By one of those accidents that baffle the necessitarians, the only sentry awake at the moment of the drop was a newcomer who did not know where the alarm telephone was; by the time he had run across and woken up the sergeant of the guard, the leading parachutists were already at the perimeter.²⁰ The whole operation was over in less than three hours, and achieved its object with light casualties – six killed, five wounded, and six missing.²¹

CHARIOT, the great raid on the St Nazaire dock gates on 28/29 March 1942, dealt with a target on which SOE's planners had long cast covetous eyes;²² but it was not accessible to agents, who had no hope of introducing the thirty hundredweight of explosive that were needed for the main charge. (Letac had offered to tackle it; but only proposed to dislocate it for a week.²³) This charge was made up at SOE's station XII, where all the demolition parties were given special training; with effective results, for SOE had accumulated a formidable quantity of technical intelligence, both on the dock gates and on other installations in the dock area, which helped the commandos to make a thorough shambles of the main dockyard besides destroying the only dry-dock in France big enough to hold the *Tirpitz*.

For RUTTER, the assault on Dieppe (19 August), SOE also provided many stores and much advice; this time to little purpose, as hardly any of the demolition targets were reached by the landing force. (That is another story.) SOE sent also several of the observers who accompanied the doomed expedition; among them de Guélis who never got ashore, Harratt who was wounded, and Wyatt the liaison officer to COHQ, who was left behind and later killed while trying to establish contact with local resisters. His death precipitated a new liaison system in London, by which a dozen GSO Is and IIs made contact direct with their opposite numbers on CCO's staff; Tracy the new liaison officer and his decorative secretary and successor Vera Stratton confining most of their attention to technical points. There was not much that combined operations could do to help SOE, apart from providing a few prisoners for interrogation; nothing came of various proposals to slip agents into France under cover of commando raids. (This was probably as well; no agent wanted to start work in a fully alerted area in the forbidden zone, and few commando raids went off quite unnoticed.) Conversely, there was a good deal that SOE could do to help CCO's various organizations, not only on technicalities. The nature of the clandestine weapon was ill understood by most of Mountbatten's staff, who sometimes asked SOE to do the impossible. Once one of CCO's planners – a novelist by profession – invited SOE to arrange for a hundred and fifty parachuted engineers to be received by agents who would supply them with fire engines and firemen's uniforms, in which they could travel to demolish a nearby U-boat base the RAF was to attack with incendiaries;²⁴ but such romanticism was extreme. On a more humdrum and day-to-day level, SOE's staff willingly shared such knowledge as they had with people from COHQ who had good reasons for inquiring, and SOE was kept informed of CCO's main intentions and achievements. No one expected that such information should be reciprocated.

There was one SOE invention the reader will naturally expect to hear more of, in the context of combined operations and U-boat bases: that is the welman or one-man submarine. There were many long debates and discussions about where and how it could be used;²⁵ for our purposes the result can be summed up in eight words – the welman was not used in French waters – and the subject laid aside.

On another and less vital naval front CD and the CCO were more easily able to work together. The CCO had little difficulty in mounting operations when and where he wanted, and by a series of personal accidents SOE could provide a small force of highly skilled and intelligent toughs of several nationalities, many of them yachtsmen, who were looking for targets. This body, the Small Scale Raiding Force, had been assembled within M section by a regular gunner, Gus March-Phillipps, who had had plenty of small boat experience in the Channel and early felt a vocation for small operations; his fiery, disdainful, self-assured manner left an unforgettable impression of

force, and men who worked under him came near to worshipping him. His second-in-command was Geoffrey Appleyard, a handsome Cambridge graduate with a first in engineering and a half blue for skiing. The two of them had sailed out to tropical waters in the summer of 1941 in a sixty-five-ton Brixham trawler, the *Maid Honor*, with a small crew that included Andy Lassen the Dane who died winning the vc in Italy, at the end of the war; in her they scored a number of piratical successes for SOE.²⁶ Early in 1942 the SSRF was settled at Anderson Manor near Blandford, with the cover description of 62 Commando. While SOE continued to administer it, CCO took over its operational control; undertaking to mount no raids with it without CD's prior consent. March-Phillipps proposed to use his men to get in contact with patriot forces near the coast; but he made no contact with the gaullists, whom he regarded as hopelessly insecure, and was not in touch with F section either. The CCO secured a couple of naval motor launches for him – *Maid Honor* had to be left in the tropics, and was in any case far too slow for Channel raiding work – and with these his party made several crossings to the French coast and its offshore islands, for the preliminary purposes of gaining intelligence about the German coastal garrisons and inspiring them with alarm.

Appleyard's family claim he took part in as many as seventeen raids in which a landing was made in enemy-held territory.²⁷ About half of these seem to have been on north French or Channel Island soil, though 'soil' is a euphemism for the uninhabited, granite-studded islet of Burhou, west of Alderney, to which his navigation skill guided a small party on 7/8 September 1942 (BRANFORD). The net gains from the raids were not large: some useful details about lights and tides; three Germans killed near St Vaast, east of Cherbourg (BARRICADE, 14/15 August), and three more near Paimpol (FAHRENHEIT, 11/12 November); seven prisoners from the Casquets lighthouse (DRYAD, 2/3 September – an operation so often postponed that the force talked of 'DRYAD weather' when it blew hard), and one from Sark (BASALT, 3/4 October).²⁸ March-Phillipps himself was killed, with most of his ten companions, in a raid near Port-en-Bessin (AQUATINT, 12/13 September);²⁹ this little fishing port was later the scene of an ample act of revenge, for it lay in the middle of the main NEPTUNE beaches when France was re-entered in 1944. SSRF never recovered from his death and from the aftermath of the Sark raid – five prisoners had been taken; four had tried to escape, and were dispatched at once; and one of them was found next day stabbed to the heart with his hands tied behind his back. Several thousand Canadians captured at Dieppe were manacled for some months in reprisal; the long-term results were more disagreeable still. For it is a reasonable surmise that it was news of BASALT that inspired Hitler to issue his murderous 'commando order' of 18 October. BASALT provided him with just the sort of one-tenth-genuine excuse for illegality his evil soul delighted in.

At the time he was taking so much interest in raids and sabotage, and

their repression, that he spent thirty to forty minutes on these subjects every day with his chiefs of staff.³⁰ One of these men, Jodl, later testified when on trial for his life that Hitler had been simmering about commandos and parachutists for some time, and that ‘the turning-point with the Führer’ was reached when he saw some captured Canadian instructions for unarmed combat at the same time as the raid on Sark;³¹ the coincidence of dates between the raid and the order is strong. On 7 October, three days after the raid, the order was foreshadowed in a sentence from Hitler’s own hand in the daily Wehrmacht communiqué: ‘In future, all terror and sabotage troops of the British and their accomplices, who do not act like soldiers but rather like bandits, will be treated as such by the German troops and will be ruthlessly eliminated in battle, wherever they appear.’³² Ten days passed in discussions among lawyers and staff and security officers in the German high command;³³ the order was then issued, in strict secrecy – unlike the communiqué, which had been broadcast. It laid down that all sabotage parties, in uniform or out of it, armed or unarmed, who fell into German hands were to be ‘slaughtered to the last man’ by the first troops that encountered them; save that any who had already been arrested by local police forces were to be handed over at once to the SD.³⁴ Everyone knew what that meant. A lot of German senior officers protested afterwards that they had disliked this order; as Jodl put it at Nuremberg, ‘it was one of the few – or the only – order I received from the Führer which I, in my own mind, completely rejected’. Cross-examining counsel rejoined, ‘You rejected it, but these young men went on being shot, did they not?’³⁵

SOE’s losses as a direct result of this order were not especially heavy in France; in any case, agents in plain clothes were aware that international law did not extend to them the sort of cover that the Hague conventions gave to people in uniform. But several uniformed parties of SAS prisoners got short shrift from SS troops who captured them; others, less fortunate still; were handed over in accordance with the same order to the SD, and were executed – later. And let no one think that because the ‘commando order’ derived, in part, from BASALT it was in any sense SOE’s or CCO’s ‘fault’: the fault lay with Hitler, and with the subordinates who having sworn allegiance to him felt themselves bound to go down with him into the pit.

Appleyard the new commander of SSRF felt uncomfortably responsible for what happened to the Canadians, which was public knowledge; though he did not see what else, in the time-trouble induced by strong tides, could have been done to force a reluctant prisoner through the moonlit gorse but tie him up, and held it excusable that he was stabbed quickly when sudden tumult broke out round him.³⁶ He took the remains of SSRF out to north Africa to work under CCO in the spring of 1943, raided Pantellaria with them; and vanished on an SAS operation in Sicily next July.

Contact achieved with French resistance by these raids had been nil. This was hardly unexpected: the forbidden zone was fullest of German troops,

most strictly controlled, and of all resistance areas the least developed. In the hinterland resistance could and did develop far more easily.

Again it will be convenient to survey the field by SOE's sections, and to dispose of the smaller ones first. EU/P's contribution was practically confined to a long and bitter quarrel about the nature of Dzieřgowski's mission ADJUDICATE. The evidence about this, like all the available evidence about these Poles, is tenuous; moreover in this case it was recorded thirteen years later, to help in some litigation then pending. In a paper of July 1955³⁷ Hazell specified that Dzieřgowski's tasks were 'to investigate what was going on and to see whether an independent Polish sabotage organization could be set up under direct British SOE control'; SOE covered his costs and paid his sub-agents. His role was more one of reconnaissance than of execution: SOE were frankly puzzled about what was going on, and he was sent to find out. There was no long-term plan to set up a new section as independent of the London Poles as F section was independent of the Free French.³⁸ However, when he got back to London in May 1942 after a particularly hazardous journey across Spain 'the Polish Prime Minister was incensed to hear that SOE had, as he put it, attempted to set up an independent organization in France behind his back', and SOE had to disavow the mission.³⁹ The only other EU/P event of importance in 1942 was the brief extraction from France by the September felucca of General Kleberg, who headed such secret Polish forces as existed there; he discussed their possible uses at a meeting with Sikorski, Selborne, and Gubbins on 14 September,⁴⁰ but their conclusions are not recorded, and felucca operations apart the net results of EU/P's work this year were nil.

DF's effort was also small, but the net results were striking. Gerson returned to France on 21 April, guided to the Riviera shore by Peter Churchill from a submarine, and set about organizing his VIC escape line. He recruited George Levin as his second-in-command in Lyons, the hub of his circuit; Levin like himself was a Jew, and they recruited several Jewish friends, notably the two Racheline brothers. As Jews, they all ran bigger risks than gentiles in working against the Germans, but were even more determined anti-nazis; and as Jews they had had some experience of keeping themselves to themselves, a substantial advantage for escape line workers in an extrovert open society. Jacques Mitterrand, an old friend of Levin's (and brother of the future President), was persuaded by him to give up editing an underground newspaper, the *Courrier du Peuple*, and to become VIC's chief lieutenant in Paris instead. While Levin and Mitterrand were organizing reliable friends in courier and safe-house lines, and getting an adequate team of forgers together to keep escapers supplied with the documents they would need, Gerson himself engaged in the trickiest negotiations, with *Martin* the Spanish republican general who looked after the actual crossing of the Pyrenees between Perpignan and Barcelona. An advance base at Perpignan, not overlapping with the EDOUARD line at all, took a little while to set up securely; it

was here that VIC's escapers had to be passed over to the Spanish frontier guides, as obscurely as could be (one or two early travellers by this line complained that its agents looked too conspiratorial). After four months' hard work Gerson was able to revisit London – by his own route, naturally – to report his success; he returned to France late in the year to resume his merchanting cover and to keep an eye on a set of arrangements that were running smoothly and well.

F's activities during this year were much more complicated, but less effective. Problems of communications remained severe, though by the year's end wireless interchange with the field had become commonplace, there had been one more successful Lysander pick-up, and a few more stores drops had been made to reception committees. The Foreign Office's ban on serious activity without prior consultation continued; but as the section's opportunities for serious activity remained small, the ban's importance was slight.

All through the year F section staff toyed with coups de main; several were proposed, but only three men actually left the country, and they all failed. Norman Hinton, a wild and unpunctual Australian art student of 28 with a good deal of skill in fieldcraft, parachuted into France late in November on a lone wolf mission of which no trace remains in his file but a note that 'he did quite well';⁴¹ what he did was to extricate himself from a too well guarded area into a safe house. The other BOOKMAKER party, J. A. P. Lodwick,⁴² a youthful novelist who had fought in the foreign legion in 1940, and Oscar Heimann, a Czech Jewish dentist of forty, were dropped blind on 29 December near La Rochelle to attack a factory that was working for the Germans. Heimann hesitated before he left the aircraft, and consequently fell rather wide of his companion; neither could find the other in the dark. As Heimann had all the explosives and Lodwick had all the information about the target, neither could attack it alone. They made, separately, for a safe house in Paris, where they quarrelled sharply; returned through Spain, having accomplished nothing, with Hinton; and were all posted out of SOE. That concluded F's coup de main record for 1942.

But before we consider the rest of F's operations this year, we must rescue Pierre de Vomécourt (*Lucas*) from the predicament we left him in. Early in 1942 he discovered that Mathilde Carré (*Victoire* or *La Chatte*), his only channel for communication with London, was in fact acting for the Abwehr, to which his messages had been betrayed. The correct course for him to take was to vanish at once, not even pausing to assassinate her if her death was going to complicate his escape. But he had the hardihood, or foolhardiness, to remain in close touch with her; and his temerity brought the reward that waits on boldness. He managed to secure so strong, if temporary, a hold on her that she agreed to turn coat again. She had been an allied agent; had become a double agent, maintaining touch with the allies while really working for the Germans; and now became a treble agent, maintaining touch with

the Germans while retransferring her loyalty to the allies. This, essentially, was the feat that earned her in so many newspaper articles the title of ‘Mata Hari of World War II’; it called for a degree of skill and nerve on her part and on his that may not have been appreciated by their many detractors. Among de Vomécourt’s achievements, this successful turning round again of Mme Carré stands second only to his indispensable contribution towards getting organized resistance going at all.

With a good deal of dexterity, they managed to sell to the Germans – through Bleicher, the NCO who was her Abwehr contact and her lover – the idea that de Vomécourt should be taken back to England by any channel London cared to offer, and that she should go too. A triple bait was held out: the enemy could observe in every detail how the pick-up was conducted; they would no doubt hear through the INTERALLIÉ wireless, to which London continued to work, when de Vomécourt returned, and by trailing him could uncover the full range of his activities, perhaps even capturing a general who was to be sent specially from England; and from Mme Carré who would return with him they were to find out how London organized clandestine war. In retrospect the bait looks too conditional to be really enticing, except for the first tidbid about watching an air or sea pick-up; but the Germans rose to it.

Negotiations lasted some weeks. At length a Lysander was arranged; Bleicher, disguised as a Belgian, went with them to the landing ground; no aircraft came. In the end, Pierre de Vomécourt, Mathilde Carré, and Ben Cowburn found their way to a remote Breton cove near Locquirec at midnight of 12/13 February 1942 – almost in the wash of the *Scharnhorst*, whose voyage up channel a few hours earlier had been much helped by false reports planted on the Admiralty through INTERALLIÉ. An MTB presented herself punctually also, and came so close to the shore that someone’s white coat could clearly be seen on her bridge (Bodington was wearing it). Unluckily ‘the sea suddenly began to get rough, a sort of heavy swell began to develop with the rising tide’,⁴³ and the light dinghy which landed two F agents overturned when Mme Carré tried to board it. De Vomécourt dragged her ashore, where she stood, furious and dripping, in a fur coat, lamenting her lost suitcase which had gone overboard with herself and the new agents’ luggage. Two sailors eventually righted the dinghy, but failed in repeated efforts to get close enough inshore to take off either the waiting agents or an Australian sub-lieutenant who had gone ashore first of all to make contact. A second dinghy could do no better – Cowburn described them as ‘absurd little things ... about as seaworthy as an inverted umbrella’;⁴⁴ nor could a larger rowing-boat. The MTB, tied to a rigid timetable by impending daylight, withdrew at half-past three. Bodington’s report on his return was a masterpiece of unconscious irony:

I think this operation tends to prove that the *Victoire* line of communication is not working under enemy duress. It is surely unreasonable to believe,

had the enemy been in full possession of the details of this operation, that he would not have taken advantage of capturing all the people collected on the shore in addition to a fully equipped MTB with outside personnel on board, and which could not escape from the somewhat perilous neighbourhood except at most at half-speed.⁴⁵

Several Germans had been lurking in the cove; and Black the Australian, who was in uniform, soon gave himself up. The two newly landed agents, G. W. Abbott and his wireless operator G. C. B. Redding,⁴⁶ cleared off quickly, as they were warned in a whisper by de Vomécourt that there were Germans all round them; but by bad staff work no one had told Abbott where they were going to land, or given Redding more than a glance at a Michelin road map of the neighbourhood. They stumbled through the darkness till they found an isolated farm, hid in the barn, introduced themselves to the farmer next day; and were sold by him to the Germans the day after. Thus ended their mission, which had been to probe and report on the reliability of the AUTOGIRO circuit.

De Vomécourt and Mme Carré returned discomfited to Paris, and arranged a fresh sea pick-up; this only involved them in another cold night by the sea (19/20 February), signalling fruitlessly from the wrong beach. Cowburn got away that night over the Pyrenees, having slipped his German shadow without difficulty. He reached London next month; but his companions were there before him. For at last, on 26/27 February (the night before the Bruneval raid), this time by nearly full moonlight, the wandering couple, the German spectators, the MTB, and calm water all foregathered at the right beach, and the collection went off without a hitch.

De Vomécourt was at once swept up into the staff stratosphere – Gubbins took him on 28 February to call on the CIGS, who cross-questioned him about the morale, strength, and habits of the German army in France,⁴⁷ and he saw Eden not long afterwards. The agent's buoyancy seemed unimpaired by strain, and he was anxious to leave again for France immediately – taking Mathilde Carré with him of course – both to rescue his imperilled circuit and to conduct a number of coups de main, starting with the assassination of Bleicher. Gubbins had to slap these extraneous projects down firmly, at a long and unbusinesslike meeting on 7 March with him, D/R, and Bodington; 'it was lunacy to risk [him] being caught for the sake of these special operational coups'.⁴⁸ He had to break it to de Vomécourt also that the agent would have to return alone; it took nearly a fortnight for this to sink in.⁴⁹ Meanwhile there was plenty of staff work to be done, choosing the nodal points in enemy communications most suitable as targets for the sabotage teams he was to organize on his return. The main point of having any SOE forces in France, as Gubbins envisaged it at this time, was that 'when invasion came we would have men there to attack and cut communications and generally hinder German action. This would be of real

benefit at the critical moment, even if the Germans were only held up for 48 hours'.⁵⁰ And as de Vomécourt had got off to a flying start in collecting and organizing these shock troops, it would have been absurd not to support him.

No wireless operator was ready to leave with him; he jumped back alone into France on 1 April, landing on his brother Philippe's estate near Limoges,⁵¹ and was soon back in Paris picking up the threads of AUTOGIRO. He took a new field name with him, *Sylvain* instead of *Lucas*, and the INTERALLIÉ wireless was told *Lucas* would be returning to France by the following moon. Cottin had kept charge of the circuit deftly enough, during the leader's absence in England; but with no explosives, few arms, no circuit wireless and no directive there had been little anybody could do but talk. Burdeyron in central Normandy had found one way round the lack of explosives; he derailed a couple of German leave trains by removing a rail – a slow, noisy, and cumbersome expedient, which desperate agents could turn to as a last resort – and caused some casualties, but not many.⁵² Everyone else was waiting on London for orders; the orders Pierre de Vomécourt brought with him could not be implemented without arms; and the arms could not readily be supplied without wireless. As it was, *Georges 35* who should have been operating for him had gone to ground. So de Vomécourt's best means of communication was by courier through Virginia Hall at Lyons; and his messenger was picked up in the third week of April by a routine army control on the demarcation line. The papers the messenger was carrying found their way to Bleicher's desk; Bleicher recognised de Vomécourt (*Lucas*)'s handwriting on a report signed *Sylvain*, and moved in to collect everybody he knew of. He started by arresting Cottin, who kept an exemplary silence under interrogation. His second arrest was more fruitful: he caught on 24 April a Belgian sub-agent, Leon Wolters, in whose flat de Vomécourt was living; and Wolters, more or less unwillingly, enabled Bleicher to arrest Pierre de Vomécourt at a café rendezvous next day. Jack Fincken, who had been parachuted in to help him in January, by the aircraft that carried *Georges 35*, was taken with him. Burdeyron, du Puy, and several of their French friends followed them into the net, and AUTOGIRO as a working circuit was snuffed out before ever it had got properly alight.

Its arrested agents were all put on trial before a court martial in Paris, at the end of the year⁵³ (this treatment was altogether exceptional). At the trial, by a final effort of personality, Pierre de Vomécourt persuaded the Germans to treat him and all his captured companions – Abbott, Redding, and Black included – as officer prisoners of war,⁵⁴ and they came back in the end from Colditz. (Wolters was excepted; the Germans released him, believing he had been frightened into acquiescence with their regime. They never knew that his brother Laurent was a leading figure in the Belgian secret army, or that his flat was often used as a safe house by Belgian resistance leaders passing through Paris.⁵⁵ Bloch the wireless operator was also of course excepted: for

he had already been shot.) As it turned out, this AUTOGIRO party accounted for nearly a quarter of the F agents who fell into German hands and survived.

Mathilde Carré also spent the rest of the war in confinement, in more comfortable but more lonely conditions. As soon as it was clear to London that the bulk of the AUTOGIRO agents were under arrest, SOE relinquished any remaining interest in her to the security authorities; who had much to talk to her about. As a result of her own frank admissions of co-operation with the enemy, she was detained under defence regulations for the rest of the war in Holloway and Aylesbury gaols, and then deported as an undesirable alien to Paris, where she was met by the French police. In France, she was tried; sentenced to death; reprieved; and ultimately released. She is still at the time of writing alive, though nearly blind; living in strict privacy varied by occasional forays into journalism.

The final defeat of AUTOGIRO left F section without any organized circuits in occupied France at all; indeed with hardly a single useful agent, apart from inspector Philippe de Vomécourt re-routeing railway trains when he had time to spare from other work (Leroy had by now left Bordeaux and found his slow way back to England through Spain). Nor of course could London know promptly what had happened: Virginia Hall, always well informed, sent word through by the end of May. But AUTOGIRO, like a headless chicken, did not die instantly; an agent left to join it, when there was nothing left to join. This was Christopher Burney, a young and thoughtful former commando subaltern, who was dropped blind near Le Mans on the last night of May. His orders were to find Burdeyron, by way of a contact house in Caen, and act as his assistant. He was observant enough to notice the contact house was being watched, discovered in time that his organizer was in prison, and had the enterprise to try to set up a circuit on his own account instead of leaving at once for Spain; it was eleven weeks before the Germans caught up with him. They arrested him, in bed, early one mid-August morning; he gave them a good deal of trouble. When several brutal interrogations had disposed of all his cover stories and the Germans found out his true name, he told them nothing else useful but his rank and number; they never discovered by any admission of his such little progress as he had managed to make. Their retort was to leave him in a cell by himself. This can be exhilarating enough – for a few days; in his case it was prolonged for eighteen months, which would reduce most people to apathy or madness. It left Burney lively enough to organize a resistance movement inside the concentration camp of Buchenwald, where he spent the last fifteen months of the war planning how to seize control of the camp; he survived to tell the tale.⁵⁶

Burney had worked alone, but a companion had accompanied him to France:⁵⁷ a companion intended by London as a hedging bet against the probability that Pierre de Vomécourt's circuit was already in trouble. This was Charles Grover-Williams (*Sebastien*), a thoroughly English racing driver

who spoke excellent French. During the previous struggle he had been chauffeur to Sir William Orpen the war artist, and had married one of Orpen's most delectable models, Yvonne Aubicq. He had no trouble steering clear of AUTOGIRO, for it had vanished before he arrived. He collected some reliable friends in the Paris motor racing world, headed by Robert Benoist a former world champion. They settled down on the Benoist estates south-west of Paris, and put together a small secure group of close acquaintances and retainers, to which London dropped half-a-dozen loads of arms during the following twelve months. This was a sound organization in being, and small enough to come to no harm by lying low for a while; though its eventual achievements were not large.⁵⁸

It had been sensible to send CHESTNUT'S organizer to supplement the more energetic though more volatile organizer of AUTOGIRO; but Grover-Williams's instructions had pinned him down to minimal activity. Did this really meet the strategic needs of that summer?

As a matter of fact, it was not until 13 May 1942 that SOE received its directive for the year from the chiefs of staff. They envisaged substantial air and coastal raiding for the rest of the year, culminating in the seizure of the Cotentin, and 'A large scale descent on Western Europe in the spring of 1943.' They laid down that 'SOE is required to conform with the general plan by organizing and co-ordinating action by patriots in the occupied countries at all stages. Particular care is to be taken to avoid premature large scale risings of patriots ... SOE should endeavour to build up and equip paramilitary organizations in the area of the projected operations. The actions of such organizations will in particular be directed towards the following tasks ...

- (a) Prevention of the arrival of enemy reinforcements by the interruption of road, rail and air transport.
- (b) The interruption of enemy signal communications in and behind the battle area generally.
- (c) Prevention of demolitions by the enemy.
- (d) Attacks on enemy aircraft and air personnel.
- (e) Disorganization of enemy movements and rear services by the spreading of rumours.

(These five particular tasks were put under an original heading of 'Co-operation during the initial assault'; but four further 'tasks after landing' – the provision of guards, guides, labour, and raiding parties – were later deleted.) In an attenuated form, these instructions percolated down SOE's chain of command to country sections concerned; and they inspired the attention lavished on SSRF by SOE and CCO alike. But with SSRF Buckmaster's section had nothing to do; staff and agents were both still feeling their way, trying out various methods to see which would work.

Yet one more agent had been on his way to join AUTOGIRO before it collapsed – Marcel Clech, the Breton taxi-driver who had been on that first abortive motor-launch party more than eighteen months before. He had been trained since then as a wireless operator; and was to have joined AUTOGIRO direct, by boat to Brittany in February. His departure was one of the many things that went awry that month. Eventually, with Gerson, and bearing the field name of *Georges*, he had been delivered to the Riviera coast in April from one of Peter Churchill's submarine parties. He visited Virginia Hall on his way north, and she diverted him on an errand to collect an old transmitter of Bégue's hidden near Châteauroux. So news of the troubles in Paris caught up with him in time; and he moved aside to join a small circuit starting up in the Loire valley round Tours. This was MONKEY-PUZZLE, under Raymond Flower (*Caspar*). Flower, a thirty-year-old British subject born in Paris and brought up in the French hotel business, was brave and cheerful enough, but undistinguished for security sense or forethought. Parachuted blind on 27 June, he made a few useful contacts; but Clech's wireless was under constant search by direction-finders, and the circuit never got going properly. It was wound up next spring; Flower was flown back to England in mid-March 1943, and spent the rest of the war on training and on liaison between F and RF sections. Clech was also brought out next spring, by air; complaining a good deal of the tendency of French groups he had worked with to tread on each others' toes.

The other parties working the middle Loire were potentially more formidable, though for the time being they were little more effective. Cowburn on his second mission parachuted into the Limousin – forty miles wide of the intended spot – on 1/2 June. He took with him E. M. Wilkinson, an RAF officer of forty who though born in Missouri spoke better French than English; and they started by looking for a wireless operator. With Miss Hall's help, they met Denis Rake at Lyons; though he had not got a set with him. Rake (*Justin*)⁵⁹ had reached France by felucca on 14 May and had so far been transmitting for another operator, Zeff, when he had time to spare from avoiding the French police. The police were on his trail because a careless companion, who had landed from the same felucca and gone to stay with an aunt, had told her what he was doing without reminding her to be discreet or discovering she was a Pétainist; on being arrested he had promptly talked. Cowburn and Wilkinson set off, by a circuitous route, for Paris – a risky place for Cowburn to visit, as the Germans had hardly had time to forget him. But it was Rake who was arrested, from a description given by his captured colleague, as he was crossing the demarcation line at Montceau-les-Mines on his way to join them. He soon managed to charm his French guards into letting him jump off the train as it was taking him to gaol. To get a transmitter he returned to Lyons with Wilkinson, travelling this time – improving on a suggestion of Cowburn's – in the fuse box of an electric train.⁶⁰ Rake and Wilkinson got their set at last; and they got a valuable

companion, Richard Heslop a recent felucca arrival who was heading for Angers.⁶¹ The three of them set off together on a cross country journey to their working area; they paused overnight at Limoges, where Rake made a slight slip at a routine French police control as a result of which all three of them were arrested – the other two not over-pleased with him – on 15 August. A pair of trivial points turned the scale against them. Rake and Wilkinson, who purported to have only just met, were each carrying plenty of brand new unpinned thousand-franc notes, numbered in a single consecutive series; and their identity cards, ostensibly issued in different towns, were made out in the same handwriting.⁶²

Cowburn, calling on Virginia Hall again with a message dropped from London, heard from her they were in prison, and resigned himself to working alone. He received two drops of sabotage stores, already arranged for through Rake's wireless, on Chantraine's farm near Châteauroux; persuaded some friends to introduce abrasives into the local aircraft engine factory's machinery; and supervised a multiple attack on the high tension lines round Eguzon power station on 10 October, which cut them all for a few hours. But he could not work indefinitely single-handed, and came back to London a fortnight later by Lysander.

One other agent headed for the middle Loire from the Riviera coast in August 1942: Yvonne Rudellat (*Jacqueline*), the third woman to be sent to work in France for F section, and the first of a short but distinguished line of couriers. French-born, fortyish, and separated from her Italian husband, she had been a receptionist at a small west end hotel; her cheerful, fluffy manner concealed steady nerves and sound sense.⁶³ She settled down unobtrusively at Tours to establish herself a cover and await orders from Suttill her organizer, whose arrival was held up for some time.

He was in fact preceded by a week by another woman courier, half Mme Rudellat's age: Andrée Borrel (*Denise* or *Monique*), who was parachuted quite close to Paris on 24/25 September – the first woman to land in this way – to prepare the way for him. On 1/2 October Francis Suttill (*Prosper*) dropped himself, near Vendôme, with J. F. Amps (*Tomas*) as his assistant. Amps had been a Chantilly stable hand; a tough, cheerful little man, keen to fight Germans and inconspicuous in a crowd, he turned out not to be much use in the field, for he handled written messages with difficulty and was no good at codes: in the end he was left to live quietly with his French wife, and did not escape the downfall of the rest of the circuit.

Suttill's task was to re-create an active circuit in and round Paris. His mission provides a good example of Dansette's image: 'the persevering efforts put into clandestine recruiting, grouping, organization of future insurgents, were a sort of Penelope's web, continually unpicked by the Gestapo, of which the bloody threads were obstinately re-knotted night by night'.⁶⁴ Born in 1910 near Lille of an English father and a French mother, he spoke good French, though not with a French accent; he could easily pass

for a Belgian. Suttill was a brave, ambitious man of strong character, with marked gifts of leadership and charm; he had also the nimble wits common in his profession of barrister, and rapidly got to work. He was not particular about where he made his contacts; Armel Guerne, who became his friend and his second-in-command, first met him in December at a night club in Montmartre where Suttill and Andrée Borrel were demonstrating sten guns to an interested mixed audience.⁶⁵ Others of his working acquaintance were in the Paris FTP. A wireless operator, Gilbert Norman (*Archambaud*), dropped a month after himself, to a reception arranged by Yvonne Rudellat near Tours; and work expanded so fast that a second operator, Jack Agazarian (*Marcel*), was sent in at the end of the year – dropping in the Seine valley near Les Andelys, upstream of Rouen – to help with the volume of traffic.

But though Suttill, like Pierre de Vomécourt, was an active and wide-ranging organizer, PROSPER was not quite AUTOGIRO rebuilt. For one thing, Pierre de Vomécourt though largely English-educated was wholly a Frenchman, while the half-English Suttill could not easily present himself as one; he was also much less familiar with the current details of daily life in France, and Andrée Borrel had to travel with him almost everywhere at first, lest his lack of knowledge led to some awkwardness. This was a slight but significant difference between them; the other was more substantial. Suttill's principal contacts had been provided by CARTE, the organization that deluded F section throughout 1942 with the belief that it was an excellent and wide-ranging body capable of doing great things, whereas de Vomécourt had ferreted out his own; the CARTE contacts helped in PROSPER'S downfall. As CARTE'S headquarters lay in the unoccupied zone, it will be discussed at length in a few pages' time; one more area of the ZO remains to be mentioned meanwhile, as it was seriously penetrated this year.

This was Bordeaux, where a thirty-five-year-old Mauritian agent of exceptional character, Claude de Baissac (*David*), eventually produced results of exceptional merit. He was once described by Buckmaster as 'the most difficult of all my officers without any exception', but he was also particularly good at his job, and suffered no fool gladly. His route to his target area was circuitous. He and Peulevé his wireless operator were dropped blind on 30 July near Nimes, from far too low; he broke an ankle and Peulevé had a severe multiple fracture of the leg. They had the good fortune to stumble straight away on Frenchmen who could arrange treatment for them both in secret, and de Baissac was soon in circulation again himself, leaving Peulevé to the heroic task of a Pyrenees crossing as a cripple.⁶⁶ De Baissac had been given CARTE contacts, but thought so badly of them that he cut himself off from them at once, and went his own way. Leroy had been parachuted back into France a month before him and had gone back to Bordeaux to pick up the threads he had left behind, but an obscure muddle about a contact address seems to have kept Leroy and de Baissac apart in the field for months; and de Baissac pressed on by himself with a preliminary reconnaissance of his

SCIENTIST circuit's future area of work. Possibilities seemed good, and by the slow channel of messages through Lyons he asked for reinforcements. His sister Lise (*Odile*) parachuted into France on the same night as Andrée Borrel – 24/25 September; she dropped near Poitiers, where her official task was to create a circuit called ARTIST, 'a new centre to which members of the Organization can go for material help and information on local conditions';⁶⁷ this did not suit her, and in fact she ranged far outside Poitou. She acted as liaison officer between the SCIENTIST, PROSPER, and BRICKLAYER circuits; and though all three of these were severely shaken by the Gestapo during the following year – by no fault of hers – she was brave, intelligent, and calm enough to extricate herself unscathed. The wireless operator SCIENTIST needed badly was parachuted in on the last day of October, in the courageous person of Roger Landes (*Aristide*), who later became one of the principal figures in this much disputed area. Meanwhile he was a more than competent operator, and supply drops to SCIENTIST could – weather permitting – begin. Within a night or two of Landes' arrival in France, Mary Herbert a FANY courier reached the Riviera by felucca – by the boat in fact that George Starr and Odette Sansom, among others, travelled in – and was soon on her way to join de Baissac, with whom she got on so amicably that they were subsequently married. She bore de Baissac a daughter, and retired with the baby to a flat in Poitiers. There she was arrested, on suspicion, by the local police, but stuck to a plausible cover story (brought up in Alexandria, deserted by husband, and so on) which carried conviction. She was released, rejoined the baby – which had been well cared for in the city hospital – and lay low till the liberation.⁶⁸ SCIENTIST, though quiet, progressed so rapidly that Charles Hayes was dropped on 26 November to relieve the intense pressure of work on the organizer, as he prepared a complicated series of limpet attacks on blockade runners in the Gironde. The first of these was almost ready to start when FRANKTON rendered it abortive; this naturally discouraged his sabotage teams, but did not make them give up work altogether. There will be more to tell of their activities in 1943.

But in following through the section's activities in occupied France before turning to the Vichy Zone, we have run ahead of time; Hayes has been introduced on his second mission instead of his first. It will be convenient to start a survey of F's work in the ZNO by seeing how his operational career began, in Philippe de Vomécourt's VENTRILOQUIST.

He was first landed in France on 14 May 1942, from a felucca (Rake landed with him); and was put in touch with de Vomécourt (*Gauthier*) by Virginia Hall. Philippe, the surviving de Vomécourt brother, received several supply drops this year, on various grounds in his home territory of the Limousin; but his interests became wider and wider. Bodington, visiting France in August, found that he claimed to control a hundred dockers and railwaymen, grouped in ten *dizaines*, in Marseilles, as well as seven groups of factory workers in Lyons and a few more in Agen and Limoges; all already

trained in elementary sabotage, and in course of receiving arms. And he had lines out as well to survivors of AUTOGIRO in Paris; particularly, to a large university group.⁶⁹ Even this extensive territory did not prevent him from ranging farther when chances offered. Hayes was supposed to be an electrical expert – his expertise was slight, as he had been a dental mechanic by trade; but it was enough for him to claim that as a technical adviser he was above employment as an ordinary saboteur. So he was ordered by de Vomécourt to reconnoitre the possibilities of sabotage at several points in the ZNO, including a power station right away on the edge of the Alps, at St Jean de Maurienne, and another in Toulon; both of them, he found, too closely guarded to be vulnerable. He thought the whole Rhône valley insecure, and the SOE set-up at Lyons uncomfortable; and when Miss Hall told him the Gestapo had a full description of him, he decided it was time to leave. She found him a line across the Pyrenees, and he was back in England in August.⁷⁰

André Simon, son and successor of the wine expert, was parachuted in April with the delicate task of extracting Daladier by Lysander, a task he was quite unable to fulfil, because his prospective passenger had no desire to make the journey. Simon collected instead a young Lyons business man who was a family friend of the de Vomécourts', Henri Sevenet (*Rodolphe*); but the day before they were to have left Simon fell, through over-confidence, into the hands of the Vichy police at Châteauroux. They suspected him, because of his strong English accent, of being a German agent. Luckily for him, he was travelling under his own identity, with perfectly genuine papers (he had dual French and British nationality). These included a *livret militaire* in which a general on Vichy's security staff recognised his own signature, twelve years old, when he had been Simon's company commander. The general remembered his former recruit, and ordered the agent's release, as undoubtedly a friend and not an enemy of France.

Moreover he entrusted Simon with a new mission: to get back to London with a message from the Vichy general staff, that they only awaited instructions about how to get rid of the Germans. Simon promised he would bring back a reply. But his return was slow – he caught a felucca,⁷¹ and was not in London till late August. He went straight to Gubbins and gave him the message. Gubbins replied that Simon need do no more about it, and would certainly not be allowed to return to France with an answer; for relations with the Vichy general staff had just been put on a thoroughly satisfactory basis by a big circuit Bodington had discovered on the Riviera, CARTE. Simon's protests that he had given his personal pledge to return were overruled, and he went back to being a conducting officer. How little substance there was in CARTE's claims the narrative will shortly show. A few incidents less portentous, if quite as complicated, need to be explained first, to round off the story of VENTRILOQUIST.

London made one earnest attempt to get de Vomécourt to come over to England, partly for a rest and partly for some training. Sevenet was dropped

near Loches on 27 August⁷² to try to get him out; but de Vomécourt insisted that he did not need a rest, and asked what good training would do for a man so much more experienced than the training staff could be? Sevenet tried to turn therefore to his second task, preparing a circuit to attack the Tours-Poitiers railway line (DETECTIVE); but Philippe de Vomécourt, like Pierre, had magnetic qualities of character, and Sevenet was soon ranging all over southern France. He was in some danger in early November, when de Vomécourt's assistant J. M. Aron (*Joseph*) was arrested at Lyons station; he was right beside him at the time, and his photograph was on a railway voucher in Aron's pocket. Sevenet promptly fled southward, to find more arrests there, and retired to Gascony for the storm to blow over.

For Philippe de Vomécourt attracted storms. One of his main interests still lay in the possibilities opened up by his status in the French railway service; this had large resistance possibilities, and enabled him to carry a Gestapo pass, but in the end it landed him in a scrape. He was travelling home by train from Paris when another branch of the Gestapo took him off the train at Vierzon station; after a brief encounter with them, he was held for further investigation in a waiting-room with a score or more of miscellaneous travellers, who were called out for disposal in turn. His own description of what followed is too good to miss:

The door opened again. A soldier called out some dozen or more names. In the middle of his recital, I called out 'yes', got up, joined the queue with the others, and followed the soldier through the door. Outside the room he led the line to the left. I turned right, I walked to the end of a long passage. At the door was a German sentry. Thank heaven they had given me back my papers. I showed the sentry the Gestapo pass. He saluted. I walked past him and called to a porter.

'Is there a train leaving soon?'

'One pulling out now', he said.

'That's mine.' I rushed onto the platform. The train was just moving. I grabbed a handle, pulled open a door, swung on to the train, and blessed my luck.

The train headed northwards, back towards Paris. Some fifteen miles from the check-point, it slowed down a little. I hopped off the train, bruising myself as I flung myself clear. (At the next station, as I heard later, the train was stopped and searched – for me.)⁷³

He got away this time; but he was becoming far too well known as an ardent resister. The Vichy police arrested him at Bas Soleil at the end of October – lest the Germans did so first, they assured him; and charged and held him in prison under his other surname, de Crevoisier, a thoughtful attention that probably protected him from later removal to Germany.⁷⁴ Even in the fortress-like civil prison of St Paul at Lyons, where he was incarcerated for a nominal ten-year term, he was able to keep up some degree of communication

with London, and to organize an elaborate escape for de Lattre de Tassigny, a fellow-prisoner; of which, however, the general declined to take advantage.⁷⁵

Philippe de Vomécourt's arrest made F's activities in the ZNO a good deal duller; but they still went on. Before being pulled in, he had been concerned in another escape story, a model of its kind. All the agents taken in the Villa des Bois mousetrap at Marseilles in the previous autumn were in the noisome Béleyme prison at Périgueux, described by Jumeau as 'degrading and humiliating to the last degree. We were all thrown in amongst deserters, thieves, murderers and traitors. ... hygiene and sanitation ... were non-existent. Food was unspeakably bad. In addition to that we were plagued with vermin and disease.'⁷⁶ Only the devotion of Pierre Bloch's wife, who lived not far away at Villamblard and kept bringing them food parcels, kept the party from despair through the winter. In the spring, thanks to intervention by the American military attaché, they were moved to a nearby vichyste concentration camp at Mauzac on the Dordogne, some fifteen miles upstream of Bergerac. Bégué took charge of escape planning; got each agent to observe and describe the vital key, and manufactured a duplicate; got into touch through Mme Bloch with Miss Hall and so with Philippe de Vomécourt and VIC; and suborned a guard. Jumeau was his principal assistant; they had some difficulty in making up a team for their getaway. In the end, at three in the morning of 16 July, they unlocked the door of their hut with their duplicate key. Trotobas saw Bégué, Jumeau, Bloch, Garel, J. B. Hayes, Le Harivel, Langelaan, Liewer, Robert Lyon and Roche through the wire, and the guard came with them. The curly-haired Albert Rigoulet, who had received *CORSICAN* the previous October, was waiting for them with a lorry. He drove them twenty miles to a forest hide-out where they camped for a week; they then went in twos and threes to Lyons; where the Racheline brothers took them over and saw them through to Spain.⁷⁷ This escape released, among others, Bégué to be F section's future signals officer and four distinguished circuit heads in the persons of Hayes, Liewer, Lyon, and Trotobas: it must rank as one of the war's most useful operations of the kind.

But the uses of the Mauzac escape lay in the future; the present of 1942 had other activities deserving record. In mid-January 1942 Peter Morland Churchill (*Michel*) arrived at Miramar by submarine, bearing new orders for Duboudin (*Alain*) and Basin (*Olive*) and instructions to find out what *CARTE* was. Churchill – no relation of the Prime Minister – had been at Malvern and read modern languages at Cambridge, and at the beginning of the war was working for a Home Office advisory committee; Buckmaster took to him, and sent him on this short reconnaissance. Churchill's published account of it⁷⁸ is not contradicted by the files; intelligibly enough, it displays more interest in his own adventures than in the movement he was to explore. He spent some nights with the Lévy⁷⁹; like Basin, he found that Lévy's excellent table assorted ill with professions of communist sympathies. His host's political tendencies were indeed catholic – he seemed to belong to three or four

mutually antagonistic groups at once – and the household was not noticeably secure. Nearby Churchill met Emmanuel d’Astier de la Vigerie (*Bernard of LIBÉRATION*),⁸⁰ who travelled up to Lyons with him when he went to give Duboudin his orders; and at Antibes he found himself in touch with CARTE. André Simon, Basin, and de Guéllis had already brushed shoulders with this body; we must leave individual agents’ activities for a time, and soar with it into the empyrean.

Carte himself, after whom it was named – this was as far as its security precautions went – was André Girard, a patriot by choice and a painter by profession, who lived a few doors away from Lévy at Antibes. He was a passionate opponent of Hitler, Pétain, and de Gaulle alike, and a marvelously persuasive talker; unluckily for the causes he wished to serve, he combined an ingenious administrative talent with a total ignorance of security: – at least on the subversive front. He also ran an extensive intelligence circuit, of which one antenna reached as far as the Baltic; its results were highly regarded by the American diplomats at Vichy to which he passed them.⁸¹ He had begun to collect like-minded disciples quite soon after the collapse. By the winter of 1941–42 his contacts in the French armistice army were widespread over Vichy France and reaching into the occupied zone as well. It seemed – it could hardly help seeming – to F section that in CARTE they had found exactly what they had been hunting for; a ready-made secret army which only needed arms and orders before it was ready to co-operate in throwing the Germans out of France. Girard persuaded both Peter Churchill and Bodington, who visited him by the August felucca, that his organization had methodical plans in hand for preparing first sabotage teams, then larger guerilla groups, and finally a private army some 300,000 strong that would join the Vichy armistice army at the right moment and help to liberate France.⁸² He also insistently, and quite truthfully, proclaimed that he was not interested in politics at all and distrusted all French politicians. In fact he and his numerous talkative friends never got, on the action front, beyond the initial stage of *recensement des adhérents*. This meant drawing up lists of their members on forms devised by Girard that contained sixty-one paragraphs of personal description – name, address, appearance, telephone number, experience, specialities, capabilities, discretion, everything.⁸³ These forms – in clear – were as a rule kept in Girard’s study; sometimes his supporters carried them about with them. Over two hundred of the most important of them were being taken from Marseilles to Paris by train by a courier, André Marsac (*End*), in November 1942; he fell asleep during the long journey, and when he woke up his briefcase with the forms in it had disappeared. An Abwehr agent had taken it; CARTE’S downfall was thereafter only a matter of time.

In fact the Germans waited till after the turn of the year before they made much use of this haul; and by that time the movement’s inner contradictions had asserted themselves far enough to split it. One of the worst of these was

plain self-centredness on the leader's part. Basin once recorded that Girard intervened, alleging orders from an unspecified higher authority, to forbid an impending coup by Basin's circuit that would have put a score of railway engines out of action near Marseilles. There can have been no reason for this intervention but a jealous determination that nothing should be done that Girard had not arranged himself; and Girard himself turned out unable to arrange anything.⁸⁴

Yet before it broke up CARTE's existence had exercised a dominating influence over F's work for 1942, and had had repercussions in London far above country section level. Even to equip CARTE's projected sabotage teams with explosives and a few small arms would absorb nearly 4,000 tons of stores.⁸⁵ SOE's available air lift could not carry a tenth of that amount, and no other adequate means of transport was in sight (the abortive LAFITTE scheme was one effort to turn this awkward corner⁸⁶). Though the quantity of stores actually dispatched to CARTE was derisory, it did at least do good rather than harm to various air supply authorities in London to get an appreciation of the size of effort that was going to be needed if a general popular uprising against nazi domination of the continent was later to be stimulated with success.

When Bodington got back to London in mid-September he wrote a long, strong, and enthusiastic report on CARTE;⁸⁷ Girard had impressed him as knowledgeable and workmanlike, and what little he had been able to see of the organization had also seemed good. His character disposed him to favour the body, for he was bold to the point of foolhardiness, brilliantly clever, a superb translator from and into French, yet lacking in authoritative weight. Reading between the lines of this report it is clear that his own ideas on security were still very shaky; this is a sign that F section was not yet working at full blast. Buckmaster at once launched a proposal for an increase in staff to cover the new work that CARTE was going to make for his section;⁸⁸ more senior officers had a weightier difficulty in mind – what attitude was SOE to take towards CARTE?

The chiefs of staff were soon seized of this problem, and on 16 October they discussed it at some length, in the presence of Hambro and Gubbins. The discussion was overshadowed by the imminence of TORCH, the Anglo-American landing in Algeria on 8 November; it was agreed that 'token deliveries of supplies and equipment' and exchanges of liaison officers should go on at the same rate as before, and that was almost all.⁸⁹ But at least serious interest had been aroused.

What made people in London take CARTE so seriously was its military flavour. Though Girard himself was far from being a distinctively military character – he had only too much proverbial 'artistic temperament' – he could talk the language that was familiar to soldiers, and behind a veil of well-intended but ineffective secretiveness he let his visitors sense the presence in the background of his movement of some of the most senior

officers of Vichy's army. Whether there was anything more in these claims than in Girard's other pretensions the surviving evidence does not show. But certainly some judicious name-dropping, and the appearance of concord between CARTE and a real professional general staff, ensured a much more favourable reception for this movement in British professional staff circles than more obviously scatter-brained, boyish, or ragamuffin bodies such as OVERCLOUD or the Armée Gaulliste Volontaire could obtain. The most useful service Girard performed for the allied cause was to get senior British staff officers accustomed to the idea that they might one day co-operate usefully with large resistance movements. But meanwhile as Bourne-Paterson put it 'his head was firmly anchored in the clouds, and it was impossible to persuade him to relate his plans and dreams to such materialistic considerations of supply, finance and security as of necessity governed the conduct of operations at the time'.⁹⁰

One other aspect of London's attitude to CARTE deserves mention; for it worsened British relations with de Gaulle through the winter of 1942–43. SOE's high command had been so much struck by what it heard of CARTE, and by Girard's requests for propaganda by wireless, that PWE's interest was invited also. Girard's staff officer Henri Frager (*Paul, Louba*)⁹¹ who was in London in July 1942 and returned to France next month with Bodington (travelling each way by felucca), discussed broadcasting needs in some detail; and when Bodington left again for England he took with him two broadcasters designated by Girard. These men ran one of PWE's short-wave transmitters, called *Radio Patrie*, broadcasting regularly into France from 11 October. As soon as the gaullists discovered that these transmissions, which were many of them markedly hostile to themselves, originated in London, they gave justified warnings that it was no service to the allies to divide French resisters from each other; and *Radio Patrie* was closed down – or rather renamed *Honneur et Patrie*, and run with a different team – from 17 May 1943.⁹²

The amount of direct effort lavished on CARTE by SOE was not as it turned out extensive, though that largely abortive circuit did take up the bulk of F section's attention for most of the year, and provided many contacts for agents going out to open up new areas; most of the contacts by the bye quite useless. Peter Churchill's main role in France was to act as principal liaison officer between CARTE and Baker Street; this may in part explain what so much annoyed his colleagues on the Riviera at the time, why he did no actual sabotage work at all. To do it was only a minor part of his task, for which other preoccupations never left him time. (That it was part of his task indeed can only be inferred from a couple of indications that microphotographed notes of targets were sent to him in October; and even these may have been for transmission to somebody else.)

By the time Churchill landed in France on 27/28 August, by parachute near Montpellier as *Raoul* of SPINDLE, he had demonstrated that he was a skilled navigator who could keep his head in moments of danger; besides

putting himself ashore in January, he had conducted a number of other parties to and from submarines off the Riviera coast in April, on one occasion setting foot ashore himself for a few minutes near Antibes and collecting d'Astier who happened to be staying with the Lévys. But the kinds of nerve and skill that were needed for canoeing in the dark among unfriendly sentries were quite unlike the qualifications he needed in his new task. He specialised in lone operations. His skill as an ice hockey international and his previous clandestine gallantry more fitted him for these than for liaison work.⁹³ One of his first tasks seems to have been to attempt to rescue Basin, who had been arrested on 18 August; this attempt was called off, apparently at the request of Basin⁹⁴; so he had nothing but his common sense, a few words with the departing Bodington,⁹⁵ and a vaguely worded operation instruction⁹⁶ to guide him in his dealings with Girard, Girard's subordinates and contacts in CARTE, and his own SPINDLE team which took over from the URCHIN one. The team was diverse; it included Adolphe Rabinovitch (*Arnaud*), a young Russo-Egyptian Jew, a wireless operator with a lurid vocabulary,⁹⁷ as likeable as he was efficient, who dropped on the same night; Marie-Lou Blanc (*Suzanne*), who ran a beauty parlour and a beach reception committee at Cannes; and the Baron de Malval (*Antoine*), who had long worked with Basin – his luxurious Villa Isabelle was for months SPINDLE's headquarters. A friend of de Malval's, Colonel Vautrin, was head of the local French counter-espionage service; this friendship several times saved URCHIN and SPINDLE from disaster.

F section staff was delighted with Churchill's efficiency as a liaison officer; a view not always shared on the spot. He had taken over Basin's wireless operator Newman (*Julien*), whom he had himself brought ashore in April. Newman quarrelled with Girard, who had no appreciation of the dangers Newman ran, and insisted – to Churchill's as well as the operator's horror – on having his verbose messages transmitted exactly as written. This was more than Newman's professional integrity could stand. Churchill thought it of overriding importance to keep on good terms with Girard, so he sent Newman home on the November felucca. Newman expressed himself forcibly, on reaching London, at Churchill's treatment of him; but appears later to have relented.⁹⁸

John Goldsmith (*Valentin*) ran into similar difficulties. He arrived at Cannes by felucca at the beginning of October with Chalmers Wright of PWE; they were received by Frager and Marsac in an atmosphere of conscious melodrama. Chalmers Wright was put up for a few days with the more relaxed Audouards – Audouard belonged to a spontaneous resistance group of croupiers, with which Churchill had forbidden Newman to have any contact – and then retired to Grenoble, where he spent the winter writing reports PWE provided him with no means of transmitting.⁹⁹ Goldsmith's orders were to send a message through General Chambe to General Giraud, bearing on Giraud's impending escape, which he promptly did; and then to 'acclimatise

himself' with CARTE before going right across France to set up a small railway sabotage circuit (ATTORNEY) between Amiens and Boulogne. As it turned out, Girard would not let him get on with his work in the north, saying he was just the man to go to Corsica and get a CARTE sub-organization set up there; weeks passed while Girard and Churchill chatted over how this might be done, Goldsmith in the meantime holding classes in explosives at Nice and Juan-les-Pins. As it became clear to him that nothing was to be expected from CARTE but endless talk, he decided to leave at the end of the year, taking Chambe with him. Some Vichy intelligence officers in Toulouse helped them onto an escape line over the western Pyrenees. Near the village of Licq, some fifty miles south-east of Bayonne, they were held by the local police as suspects. Goldsmith, a racehorse trainer, was not used to such treatment; haughtily appealed over the gendarmes' heads to the patriotism of the mayor of Licq; and was safe over the mountains, with Chambe, within forty-eight hours.

Girard was enchanted by this feat, and later gave Goldsmith a *croix de guerre* to celebrate it. Girard was not amused; the internal stresses in CARTE were severe enough already, without the complications brought by ATTORNEY and SPINDLE. The leading characters in SPINDLE were Peter Churchill and his courier Odette Sansom (*Lise*). She was a Frenchwoman so combative that she had sacrificed the company of her three small daughters in England to go back to war by the early November felucca.¹⁰⁰ SPINDLE continued to please London by maintaining touch with Girard; but Churchill was too careful about security to explain his task to his subordinates and this led to some misunderstandings. Had Headquarters known then what they later learned from Churchill about the CARTE organisation they might well have pulled SPINDLE out and let it start again elsewhere. But they did not know, and thus the predicament continued. For CARTE was breaking up.

About the time that Marsac lost his brief-case, in November, the harder-headed characters in that organization began to ask awkward questions, to be less easily put down by Girard's outbursts of pique and less readily swayed by his eloquence. The much-talked-of connexions with the staff of Vichy's army became of minimal importance when the Germans dissolved it altogether at the end of the month, and the scales fell from thousands of eyes at once. Girard and Peter Churchill between them had organized one single arms drop, and collected from feluccas several tons of arms which they had not managed to store properly;¹⁰¹ CARTE and SPINDLE had no other positive success at all to show and between them had mismanaged a proposed Hudson pick-up in circumstances that reflected small credit on either.¹⁰² Frager, quite as highly strung as Girard, led against Girard's 'mysticism' a party of 'activists': the quarrel was raging furiously as the year ended, and – this we really cannot leave till next chapter – on 3 January 1943 there was a final split. Peter Churchill sided with Frager – sensibly from SOE's point of view: Frager held out more hopes of conducting some actual operations

eventually. Felucca trips had closed down with the arrival of axis guards on the Mediterranean coast; feelings at the Villa Isabelle were becoming daily more glacial; and in February 1943 Churchill took Mrs Sansom and Rabinovitch away to Annecy near Geneva, where they will reappear in Chapter IX.

Though CARTE took up the greater part of F's attention this year, it did not take it all; several other more or less disconnected projects remain to be surveyed. Though none of the rest of the section's work for the year was altogether haphazard, there was no discernible overall plan.

Three appendages of Bodington's short visit need to be noticed. He called on Jouhau at last, at Cahors; under a false identity, which Jouhau who had known him before quickly penetrated. Their long conversation convinced Bodington of the extreme delicacy of negotiations with the French trade unions up at this level. Jouhau was perfectly ready to receive assistance, in money or in kind, provided that it came from trade unions and not from governments; he assured Bodington that railway and port workers would co-operate with any allied army that landed, but clearly was unready to receive orders from any allied strategic authority; and he hedged when a transfer to England by air was mentioned. Moreover, said Bodington 'he would I think be somewhat difficult to handle politically': this put it mildly. The net results of this visit were a letter and a message from Jouhau to Citrine.¹⁰³

The next appendage can be briefly dismissed: it was the first mission of J. A. R. Starr (*Emile*, later *Bob*, of ACROBAT). Girard's parade of staff acquaintances led naturally to some discussion between him and Bodington about supply; and at Bodington's suggestion Starr was suddenly sent on a mission to find out how much help CARTE could provide in the feeding of a mobilised secret army. The new agent knew practically nothing about the subject; but when he parachuted into France on 27/28 August (not by the aircraft that carried Peter Churchill or Rabinovitch), he soon found that he knew more than anybody Girard could put him in touch with. London did not provide him with the money, nor Girard with the authority, to clinch any of several provisional deals he was able to arrange with merchants. His tact and ingenuity were admired; but some ten weeks' experience of the frustrations and fearful insecurity of clandestine group life on the Riviera convinced him that he was wasting his time. Peter Churchill sent him, with sheaves of reports on CARTE, on the November felucca, where he had the odd experience of helping ashore a passenger arriving by it who turned out to be his own brother George, the celebrated *Hilaire*.¹⁰⁴ George Starr's orders were to join an organizer at Lyons; but he arrived just as SPRUCE the Lyons circuit reached its point of maximum disintegration, with the arrest or flight of most of the agents concerned, and decided Lyons was no place for him. He retired to think things over to Gascony; which in due course he came to control.

Lyons was the other neighbourhood Bodington's journey had affected. He had seen several agents there, and tried to impose order on a set-up that had never been tidy and seemed to grow monthly more confused. Nearly a dozen people had been sent to Lyons before him to join the two who were there at the turn of the year, Virginia Hall and Duboudin, the organizer of SPRUCE, and two more couriers joined them in the autumn; the roles of all of them need explanation.

Miss Hall continued to work as *commère* and travel agent to the section; as Cowburn once put it, 'if you sit in [her] kitchen long enough you will see most people pass through with one sort of trouble or another which [she] promptly deals with.'¹⁰⁵ In Baker Street she was down as the organizer of a circuit called HECKLER, but she never in practice took on arrangements for the actual conduct of operations: she was far too busy keeping her colleagues out of trouble and in touch with London. This role of liaison involved a lot of travelling, which may have tired but never seriously troubled her; her cover remained intact, mainly because friends at Lyons police station took care not to inquire too closely into her doings. But not even her energy and finesse could get satisfactory work out of Georges Duboudin (*Alain*), then F's principal Lyons organizer. A Frenchman of thirty-four who had spent many years in London and married an English wife, he had made a promising impression on the training staff; once in the field, his achievements did not come up to their hopes of him. He had no trouble in making contact with the Lyons FTP, and was able to secure four or five drops of arms in the early summer; the details of these were arranged for him by Edward Zeff (*Georges* 53), a half-Jewish wireless operator who joined Miss Hall in April from a submarine and was passed on by her to work with Duboudin. Zeff was a man of nerve and resource, and arranged a protection team so efficient that he was always able to transmit from the same suburban house, though he said he sometimes spent as long as six hours a day at his set.

Duboudin's other contacts were with the COMBAT group, which was an RF rather than an F responsibility, and with a clandestine newspaper called *Le Coq Enchaîné*; to the *Coq Enchaîné* group he gave most of the arms that he received, but they were ill kept and he made no arrangements for training. The newspaper was run for him by another F agent, J. F. G. Menesson, a young French lecturer from the Institut Français in London who took his propagandist work seriously and did it well; but nothing much came of the contacts Duboudin early promised between this group and Herriot and Paul Reynaud, nor was their security good.

Menesson had reached France by the April felucca in company with two other primarily PWE agents; the twenty-year-old Pertschuk, headed for Toulouse, and the fifty-year-old H. P. Le Chêne (*Paul*), an hotel manager, who was also directed on Lyons. In fact after a few weeks there Le Chêne set up his circuit (PLANE) in a less congested area, round Clermont-Ferrand,

with a branch in Perigord. His wife arrived by felucca in November to act as his courier. His brother P. L. Le Chêne (*Grégoire*), nine years younger, arrived shortly after him by parachute, and reported to Duboudin as a wireless operator. *Grégoire* had seven busy months' transmitting – unlike Zeff, he found himself having to keep constantly on the move to keep ahead of the direction-finders; right at the end of the year they caught up with him at last, at his set. Le Chêne's steadfastness did not desert him when he lost his freedom; he betrayed no one at all, and survived the war after more than two years in nazi concentration camps.

On the same night, indeed by the same aircraft, as *Grégoire* – 1/2 May – an officer was sent out to resolve all this chaos: V. H. Hazan (*Gervais*). He was a young linguist, a research student at Manchester University, and quite unfitted for a labour Hercules himself might have hesitated to take on. He was to meet in turn all the principal organizers in Vichy France, and to impose on them such orders as he saw fit to keep them from overlapping. His agreeable manners unfitted him for this titanic task: voluble agents like Philippe de Vomécourt or Basin shouted him down, and secretive ones like Duboudin kept out of his way. He could not do what he was sent to do; but he found another task that he could do, and do well, ready to his hand, and did it instead. This was training the recruits, who were now numerous, in the use of British weapons and explosives. The advantage that SOE got from working in a country with a long-established conscription system was that most grown men knew something of the use and care of small arms and had a smattering of infantry tactics; but no stocks of the weapons familiar to the French were held in England, and hardly anybody who had not done an SOE course in Scotland or under Rheam understood exactly how to prepare demolitions by plastic explosive. Writing in 1962 when *les plastiqueurs* had just been busy in Paris, it was hard to remember how new were the tools of their trade; Hazan was the first man to explain to any substantial number of Frenchmen what the uses of plastic are. He called one of Girard's bluffs, and secured useful introductions to CARTE sub-agents who were unaffected by the canker at that organization's core; and during the autumn and winter of 1942–43 he trained over ninety other instructors in elementary sten, pistol, and demolition drill. Many of his teams later went into action with arms provided by other circuits, after CARTE had vanished into limbo; and his work represented a solid, valuable investment.

Two other operational agents went to Lyons at the beginning of June. One, Alan Jickell (*Gustave*), a half-French Cardiff-born shipping clerk of twenty-six who arrived by felucca, was a sturdy saboteur rather than a born clandestine. Under Duboudin's orders, he received a stores drop near St Etienne and made himself useful in teaching eight groups of local workmen how to use the stores; but his senior colleagues found him unsuited to long term serious work, and he was outpaced by their intrigues among themselves. He was sent home next spring through Spain.¹⁰⁶ The other arrival,

Robert Boiteux (*Nicholas*), was more important – so important indeed that some other agents must be disposed of before we deal with him.

Among these were the Newton brothers, known in Baker Street as ‘the twins’ though nine years apart in age. On the continent they were well known as the Boom brothers, travelling acrobats in a variety troupe.¹⁰⁷ Their parents, wives, and children had all been drowned in a torpedoed ship, so they had good reason already to loathe the nazis; time brought more. After a number of false starts, the Newtons were eventually dropped at the end of June, near Tours, to act as sabotage instructors wherever Philippe de Vomécourt (*Gauthier*) chose to send them. Brian Stonehouse (*Celestin*), a young *Vogue* fashion artist, dropped with them; he was a wireless operator, intended to work for Sevenet’s DETECTIVE as well as the Newtons.

They all had some trouble in making contact with de Vomécourt; who lost no time in explaining he hated the sight of them – arms and money, not more of London’s incompetents, were what he wanted, he said, and he packed them off to Lyons. This reception was neither tactful nor what they had been led to expect; ‘Oh, *Gauthier* will tell you all about that over there’ had been Morel’s invariable answer to the brothers’ many questions at their briefing – a ceremony at which by the bye Bodington forgot to explain to them the essential component of their personal codes.¹⁰⁸ The brothers later reported that they thought Philippe de Vomécourt and Aron ‘were bluffing ... Organization was practically non-existent at the time. Their method was to contact somebody, ask how many people they could depend on, let the [man they met] into a few minor secrets, and that was all. The figures in their reports grew gradually, but still everything remained to be done.’¹⁰⁹ One brother, Alfred, had direct experience of these exaggerated figures: he was sent down to Marseilles to take charge of a nascent group said to number ‘2,000 men impatiently waiting to be instructed and armed’, and found that they amounted to five or six dockers who could be bothered to turn up to a class and just one man who was any real use.¹¹⁰ The Newtons were tough, but they were not stupid. They could see that a lot of what their colleagues were pretending to do was sham; but they were steadily out-manoeuvred by some of the shamblers, who could outrun them in intrigue, did not hesitate to invent and spread infuriating rumours to their discredit, and managed to isolate them from Stonehouse when they eventually settled down at Le Puy. They did a sound job of work organizing and training a couple of hundred reliable men in the Haute Loire (*GREENHEART*); but had no luck with such arms receptions as they tried to arrange through Virginia Hall, as the aircraft never turned up.¹¹¹

Stonehouse meanwhile was having difficulties of his own. The container his set was carried in hung up in a tree, and it was a week before he could get it into his hands – he lived in the woods for his first five nights, hoping each day to get it down. Then, having met *Gauthier* and been rudely directed to Lyons, he had a lot of technical trouble before he could make contact

with England; then his set broke down altogether and he caught dysentery. It was not till late August that he got into proper working touch with home station; soon afterwards he was joined by a courier, Blanche Charlet. She landed by felucca at the beginning of September, and at once made herself useful finding safe houses he could transmit from, as well as carrying messages round SOE's principal figures in the south. Unluckily for them both, direction-finders picked out Stonehouse when he was engaged in a prolonged transmission, at a château just south of Lyons, on 24 October; and she was arrested when she arrived there, bearing written messages for him, a few minutes after he had been captured at his set. She remained in various French prisons, from one of which she managed to escape eleven months later, getting back to England in the end. He had more rigorous treatment, at German hands; obstinately refused to say anything of much importance to his captors, whatever they did to him; and had the fortitude and fortune to survive Mauthausen, Natzweiler, and Dachau.

But we must return to the most important man to go to Lyons this year; Boiteux. He only narrowly escaped arrest at the moment of landing, for Sheppard who jumped just behind him actually landed on the roof of a village gendarmerie near the Saône, and the hunt was up at once. But Boiteux, typically enough, got away; he seemed to thrive on narrow escapes. A London-born Frenchman of 35, he had been a Bond Street hairdresser, a gold prospector, and a colonial boxing champion; and he had a real flair for clandestine warfare as well as courage and pertinacity and the gift for learning from mistakes and doing things better next time. He was ordered to act as Duboudin's assistant, but found his organizer practically impossible to get on with. He made firm friends with two Lyonnais business men, Joseph Marchand a fifty-year-old scent manufacturer and Jean Regnier, one of Marchand's salesmen, a thirty-year-old activist of a year's standing in the FTP; both these men were later brought out to London, and headed successful circuits of their own, NEWSAGENT and MASON. Marchand soon became Boiteux' chief local assistant. When Bodington visited Lyons in August, in a further attempt to resolve the confusion there, Boiteux asked to be separated from Duboudin; but the latter was confirmed in command. This was recognised as a mistake before long; too many other agents shared Boiteux' low opinion of him, and in October he was ordered to hand his circuit over and come to England. Duboudin came back by Cowburn's Lysander, on the 26th; but his handing over consisted simply in saying to Boiteux 'Well I'm leaving now; you are in command'. This forced his successor to start practically from scratch, with hardly any arms or contacts; in any case most of the arms that Duboudin's acquaintances had got they threw into the river in November, when the Germans came, and many half-hearted resisters retired from the struggle. The tougher ones hung on.

One more visitor to Lyons deserves mention in passing. A ship owner of thirty-five, long resident in Paris, J. T. Hamilton was parachuted into the

Rhône valley on 29 December, to reconnoitre SPRUCE and one or two other circuits and report back; he was picked up by the Germans when they raided Marchand's flat a day or two later, on the hunt for a VIC line agent, and SOE lost all trace of him – he was executed twenty months later at Gross Rosen. The Marchands moved house immediately after the raid, that morning, and survived.

With so much enemy activity, the truth seemed to Boiteux to be that the prospects of successful sabotage work in the Birmingham of France were slight, except among the railwaymen; and as we shall see in a moment the railwaymen were being well enough cared for by another circuit, PIMENTO. He saw more possibilities in the country to the north and west of Lyons, where SPRUCE flourished in 1943. Already in the autumn of 1942 F had tried to open this area up a little: the HEADMASTER team were parachuted into the Puy-de-Dôme on 24 September. But C. S. Hudson their organizer was arrested a fortnight later at the house of his reception committee's chairman; and G. D. Jones the wireless operator was severely injured in a bicycle accident a few weeks after that, losing the sight of one eye for good. He nevertheless continued to transmit, even from his hospital bed, with the help of complaisant staff and fellow-patients: a technically efficient if absurdly insecure arrangement. Only Brian Rafferty (*Dominique*), a Christ Church undergraduate of Irish descent, with all the charm, vivacity, and fighting ability of his race, was left in circulation; there will be more to report of him also in 1943.

Two other considerable towns in the ZNO remained for attention by F, Marseilles and Toulouse. The Marseilles neighbourhood was an obvious one for the section to exploit. Strong revolutionary tradition, an unruly population of over half a million, some continuing economic importance, and an extensive underworld all held out inducements; but F's early activities there had been marred by the misadventures at the Villa des Bois. Only Jean Bardanne (*Hubert*), one of de Guélis's local recruits, was left on the spot, after his release from prison early in 1942; and he fell ill and faded out of the picture. Philippe de Vomécourt claimed he was doing great things, here as in other places; but the claim always took the form that men were being assembled, and awaited training. London encouraged both URCHIN and SPINDLE to work in Marseilles on some of this training, as well as working along the coast further east; the Riviera generally proved a powerful counter-attraction. Besides, the immediate neighbourhood of the great port was too heavily defended for landings by sea or air to take place there, while the Riviera coast was full of landing spots (de Guélis's Camargue contacts on the other side of Marseilles seem never to have been taken up, presumably because Turck was wrongly believed to have betrayed them). Three agents were sent specifically to Marseilles by F this year, all by felucca: Ted Coppin, a sabotage instructor, who arrived at the end of May; the handsome Despaigne in early August; and Sidney Jones late in September. Coppin performed one noteworthy feat, for he was the first agent to pass through Marseilles who got

any sabotage done there. He collected a small but efficient team of cheminots, secured a satisfactory rise in the accident rate in the marshalling yards, and made good use of abrasive grease. Despaigne was less fortunate: his orders placed him under Peter Churchill, as an extra wireless operator, and this in turn involved him in the turmoils of CARTE'S breakup. In the end, feeling he was getting nowhere, he found his own way back to England through Spain.

Sidney Jones (*Felix*, later *Elie*) got more done, during a shorter stay. Before the war he had been Elizabeth Arden's representative in France; he was just rising forty when he reached the Riviera by felucca late in September, with the mission of establishing INVENTOR as a sabotage circuit in Marseilles. By the time the Germans arrived he had several teams in working order, and had the satisfaction of burning fifty goods wagons earmarked for Germany and of doing some damage to port installations. He also sounded out de Vomécourt's and Coppin's acquaintances or contacts; he found few of these dependable, and got more help out of a pre-war friend of his own, René Dumont-Guillemet, who will reappear below. But at that time INVENTOR was too remote from base to be adequately armed; and Jones came back to England, by the Hudson that carried Girard and Vautrin, after five months in the field.

Next, Toulouse; where Labit and Forman of RF had done a little work in the previous autumn. F got involved here almost accidentally, through one of the few PWE agents used early in the field. Maurice Pertschuk (*Eugene*) was very young – only twenty – when he arrived in southern France by sea in mid-April, trained and instructed to carry out various tasks of political warfare in and round Toulouse. For the time being he was to communicate through such channels as Virginia Hall could arrange for him. When he started work, he found many more opportunities for sabotage than for propaganda, and many more people than he had expected were ready to work as saboteurs; to everyone's surprise, this mild-mannered and likeable young man turned out to have qualities of imaginative audacity that made him a remarkable clandestine organizer. He was brave and quick-witted as well as diplomatic; yet he lacked prudence and luck. SOE arranged with PWE to take him over, and called his circuit PRUNUS; and he quickly settled down to reconnoitre targets.

His acquaintances overlapped with those of an even younger and even more distinguished agent, Tony Brooks (*Alphonse*, no relation of his namesake the racing driver), the youngest agent F ever sent to the field. Brooks was an Englishman brought up in Switzerland; at the outbreak of war he was living on the French side of the Jura. By accident he happened on a private escaping from Dunkirk who was walking from the North Sea to the Pyrenees on a French vocabulary limited to *oui* and *non*, guiding himself by kilometre stones and maps stolen from telephone callboxes. Brooks could not help admiring him; got in touch with an escape organization, for which

he did a little work in Marseilles; and reached England in October 1941. SOE took him on, put him through the usual training courses, and waited for a chance to use him. Suddenly, at the end of June 1942 when he had just turned twenty, he was sent on three days' cramming on continental trade unionism, and incontinently parachuted into France near Philippe de Vomécourt's château on 1/2 July. He was dropped blind, some miles from the spot intended; with a faulty parachute which nearly killed him, as he reached ground horizontal. He landed in a tree, injuring his leg, instead of on the meadow, breaking his back; the first example of the luck that attended his mission.

His instructions were simply to explore the possibilities of anti-German action among CGT railway workers in southern France, particularly along the main lines from Marseilles to Lyons and Toulouse; and to exploit them as opportunity offered, in a circuit to be called PIMENTO. He only took a single working contact arrangement with him, apart from the address of the safe farm near Bas Soleil where he was to go on arrival; Philippe de Vomécourt soon saw him off to Toulouse, where this arrangement was to work. As he arrived at the café rendezvous he saw to his dismay an old family friend, René Bertholet whom the reader may remember as one of DF's best and earliest agents. While Brooks was wondering how to explain his presence to his friend, Bertholet came up to him and gave the password: this was his working contact. They at once arranged a courier line into Switzerland; and decided that one other family friend and only one, a Montauban garage-owner, should be let into the secret of Brooks's identity and work. Brooks went over to Montauban to see him, took a cover employment as his assistant in collecting gearboxes from the wrecked vehicles that still littered the southwest countryside from the catastrophe of 1940, and set off on his travels. Bilingual French, good manners, strong natural gifts of diplomacy; and above all the ability to summon warlike stores from the sky enabled Brooks to co-operate with a small and skilful group of cheminots to an extraordinarily successful degree, in a circuit which in the teeth of the usual rules was both far-ranging and effective. He spent all but ten weeks of the next three years in France; his circuit was occasionally penetrated by the Gestapo, but he had it so carefully organized that none of the penetrations spread outside a small group of sub-agents, none of whom were able to betray their superiors; and it crowned its continuous existence with some outstanding successes. Main line rail traffic in southern France was brought to a standstill from D-day onwards, quite as much by PIMENTO's efforts as by anybody else's.

There will be more to say of PIMENTO later; its communications need a note at once. Thanks to his courier line to Switzerland, which worked with the connivance of the staff on the trains between Lyons and Geneva, he could keep in easy touch with London: it took him about two days, when he was in Lyons, to get an answer to a message. Bertholet introduced him to Yvon Morandat of OUTCLASS, whose brother Roger ran PIMENTO's early supply

drops; to Raymond Bizot (*Lucien*), a Lyons customs policeman who was his main working contact there; and to several leading trade unionists, Jouhau included. The London staff nevertheless thought he needed prompt contact with themselves, and sent him a wireless operator, Marcus Bloom (*Urbain*, better known in London as *Bishop*), by the November felucca. Bloom was a burly south London cinema director in his middle thirties, of cheerful disposition and Anglo-Jewish appearance; he arrived in Toulouse in a loud check coat, smoking a pipe, looking as if he had just stepped off a train from Victoria. He made contact correctly with a subordinate of Brooks's at a Toulouse warehouse, and on being shown into Brooks's office held out his hand with a broad grin and a cry of 'Ow are yer, mate?' As Brooks had been at great pains to conceal his nationality from the warehouse staff, he was not pleased; and became angrier still when he found that Bloom had been in Toulouse for twenty-four hours already, having spent the previous night at Pertschuk's flat. Bloom and Pertschuk had also done some training together, and contrary to every rule had made a private rendezvous in Toulouse before either of them had left England. This was absurdly insecure, though as the next chapter will show it was not the least secure thing they did. Brooks parted from him at once, and Bloom became wireless operator to Pertschuk instead.

He took five months, owing to technical hitches, to make contact with home station; Rabinovitch had to come hundreds of miles, from Annecy, to mend his set. Meanwhile he made useful friends in Toulouse post office, and helped Pertschuk to reconnoitre industrial targets: particularly the great Toulouse powder factory, which after the French army was dissolved worked in the German interest. This was an area that held plenty of promise.

Whether any promise could be fulfilled was momentarily in doubt late in 1942; the cause of organized liberal resistance received a severe though temporary check in the last two months of the year. For when early on 8 November the Anglo-American invasion of north-west Africa, TORCH, began, it at once became clear to Eisenhower its commander that he could not achieve his object by force alone; or at any rate that he could not achieve it without incurring casualties he thought unreasonably heavy. The political key to his plan had been to spring General Giraud on French north Africa; the general had escaped from Germany in April, and a French intelligence circuit called ALLIANCE got him onto a British submarine.¹¹² But the key would not turn in the lock. TORCH's D-day found Giraud still bemused at Gibraltar, where he had arrived the night before;¹¹³ unable to comprehend the major operation of war going on round him, and complaining that he ought to have been commanding it. The first use of his name by Radio-Alger was made by an enterprising local resister who imitated his voice, broadcasting a general appeal to help the Americans;¹¹⁴ when Giraud did get round to making a broadcast of his own, nobody took any notice. Eisenhower's difficulty was acute. He felt that he could only establish his hold immediately if he could

get out of the French local authorities on the spot orders to the army and the inhabitants to do what he wanted. By pure accident, Pétain's second-in-command Admiral Darlan happened to be in Algiers at the time visiting his sick son.¹¹⁵ He was briefly imprisoned on the night of the landing by some French civilians, mostly in their late teens, who seized the city; but there were less than four hundred of them, and their hold on Algiers was precarious. Darlan had already talked his way out of custody and overawed their commander – Henri d'Astier, Emmanuel's brother, a senior administrator – before the American troops arrived. He expressed his willingness to issue the orders that Eisenhower wanted. This rescued the allied expeditionary force from various troubles in dealing with the forces and civil populations of Morocco and Algeria, who readily enough obeyed the authorities to which they were used; though it did not suffice, as Eisenhower hoped it would, to secure Tunisia too – the Germans got there first. He telegraphed to Washington on 14 November 'Can well understand some bewilderment ... Without a strong French government of some kind here we would be forced to undertake complete military occupation. The cost in time and resources would be tremendous.'¹¹⁶ But co-operation with Darlan did more than bewilder, it horrified every liberal and every socialist in Europe: all over England and France particularly there was widespread dismay. It seemed only too likely, if a vichyste regime was set up under American tutelage in north Africa, that resistance inside France would turn to communism as the only possible way of salvation from the detested 'national revolution' of Pétain.¹¹⁷ This perhaps was why Stalin, whom no one would call a liberal, thought well of the arrangements. He wrote to Roosevelt on 13 December: 'In view of all sorts of rumours about the attitude of the Union of Soviet Socialist Republics towards the use made of Darlan or other men like him, it may not be unnecessary for me to tell you that, in my opinion, as well as that of my colleagues, Eisenhower's policy with regard to Darlan, Boisson, Giraud and others is perfectly correct. I think it is a great achievement that you succeeded in bringing Darlan and others into the orbit of the Allies fighting Hitler.'¹¹⁸ Things looked different down at working level. Selborne, spurred by Gubbins, reported to Eden that the deal with Darlan 'has produced violent reactions on all our subterranean organizations in enemy occupied countries, particularly in France where it has had a blasting and withering effect.'¹¹⁹ Shoals of shocked and furious telegrams reached SOE from the field; all SOE's country section staffs dealing with France were appalled; the staff dealing with France in PWE and the BBC resigned almost to a man.¹²⁰

All these embarrassed and infuriated agents, sub-agents, and staff officers were rapidly removed from their embarrassment, for a young man walked up to Darlan on Christmas Eve in Algiers and shot him dead. The assassin, Fernand Bonnier de la Chapelle, was one of a group of five twenty-year-old Frenchmen of anti-nazi royalist inclination, members of d'Astier's Algiers group, who had drawn lots for which of them should have the honour of

killing the admiral.¹²¹ He was also, to SOE's embarrassment, a subaltern on MASSINGHAM's training staff who had been issued with an SOE pistol (whether he used it or not to kill Darlan is still in dispute). Nothing has ever surfaced to indicate that he was acting under SOE's orders, and it is reasonable to suppose that he was not. One or two of his superiors in SOE may have turned a Nelsonian blind eye; Algiers, as Darlan had just said, was teeming with plotters against himself. This one tiny group was up to action, beyond café chat.

The effect of Darlan's removal was even more encouraging than the effect of co-operation with him had been dampening to the allied cause – in France, that is; the Americans remained disturbed that so recent a protégé of theirs had been removed. His death was, from SOE's point of view, as much an accident as his presence in Algeria; it did undoubtedly help forward the task of creating a national anti-nazi revolutionary resistance movement in France to dissociate the allies from a character who had been as widely detested among French resisters as Darlan had been.¹²²

'The character of the war changed fundamentally', if we may borrow a phrase from the Marxists, three times in France: in midsummer 1940 when the Germans conquered and divided it; in November 1942 when they occupied it all; and late in the summer of 1944 when they were thrown back to their own frontiers. The importance of the change in 1942 was that ATTILA the German riposte to TORCH – that is, the overrunning of Pétain's hitherto unoccupied third of France – put the whole population under the same iron heel of direct occupation. It was no longer possible for ordinary people in the old ZNO to delude themselves into thinking the war was not their direct concern and resistance could henceforward be conducted on a national basis. The direct effect of dealings with Darlan in Algiers was fortunately slight; his death marked a check for the Americans and for the communists, but not for the mass of the French. And whatever people felt about Darlan's politics, he did hold true to the naval promise he had given in 1940: following his orders, the powerful French squadron at Toulon was sunk at its moorings by its own crews on 27 November as the Germans appeared on the quays to take it over.¹²³ This removed a possible target from SOE's reach; but a target so tricky that no plans had yet been made to deal with it. Far more important, it removed some formidable weapons out of the Germans' reach and simplified the conduct of the war; leaving only for regret that the weapons were on the harbour bottom, not in allied hands. From SOE's point of view the most important result of ATTILA was that the Foreign Office's long-standing ban on bangs in the formerly unoccupied zone of France was at last removed;¹²⁴ it was no longer necessary for sabotage there to be *insaisissable*, intangible and discreet. And in one or two places the Germans' arrival positively did agents good. Heslop, Wilkinson, and Rake were all released by a pro-allied prison governor; the first two turned their backs on Rake as they left gaol, for they still suspected him of having

landed them in it, and went on with their interrupted journey to Angers. Rake tried to make contact with Virginia Hall, who had already left, moving out in a great hurry¹²⁵ over the Pyrenees with *Cuthbert*, as F section named her artificial foot; she was held for a short time by the Spanish police, who caught her in the small hours at San Juan de las Abadesas, but was released by diplomatic intervention. Rake was less lucky; he joined a party of escaping aircrew whom he met in Perpignan, and they were all held for some months in Spain.

F section celebrated ATTLA'S widening of the scope for French resistance by injecting three of its best organizers by the November moon. On the 18th Gustave Biéler (*Guy*), the formidable Canadian organizer of MUSICIAN, dropped into northern France. (Yolande Beekman his wireless operator did not follow him for a long time yet.) With him landed Michael Trotobas – on his second tour – and Trotobas' operator Staggs. These two were to set up FARMER, a sabotage circuit based on Lille; already by the end of the year Trotobas had established himself in this promising area, where most grown men and women remembered how disagreeable German occupation had been twenty-five years before. Thousands of evaders and early escapers from Dunkirk had passed through FARMER'S neighbourhood; there were plenty of people there with clandestine experience, and plenty more with strong pro-British and anti-German feelings. What had kept SOE from earlier attempts to work up the area was the difficulty of getting close to it by low-flying aircraft: there was a big German bomber base at Merville airfield west of Lille, and the concentration of fighter and AA defences was severe. Still, the importance of the district outweighed the awkwardness of the approach; Trotobas was sent to find out how much he could do. We shall shortly see him doing rather a lot.

He could not be dropped right in his working area; the party was parachuted south-west of Paris, ten miles wide of the intended spot. Biéler had the misfortune to land hard on rocky ground and injured his spine severely. A man of less rugged determination might have asked at once for a Lysander to take him back home, or at least have lurked in a friendly hospital until he was quite fit again; but he was determined to press on, and got out of hospital as soon as he could stand. He had a bad limp for the rest of his life, as a result; he thought it more important to get on with his work than to get himself patched up properly. It may have been unprofessional to engage in subversive work with so conspicuous an attribute; it was certainly brave. And he had such a gift of leadership that years after his death men who worked with him would point out reverently the chair he used to sit in.¹²⁶ But he was bedridden till February; for the time we must simply note down MUSICIAN as a circuit *in posse* in eastern Picardy.

The third important man to go to France this month was J. F. A. Antelme (*Renaud*), a Mauritian business man in his middle forties who had already made a name for himself in SOE by some daring activities in Madagascar,

and was described by the Arisaig commandant as 'Highly intelligent ... one of the best types I have met.'¹²⁷ He was dropped near Poitiers, to a MONKEY-PUZZLE reception, on the night after Biéler and Trotobas; with several political missions. He was to get in touch with Herriot, if he could; and with the heads of several non- or anti-gaullist resistance groups that F believed could be found in occupied France, to find out whether they were of any importance. Moreover he was to make use of his extensive acquaintance in banking and business circles to arrange eventual supplies of currency and food for the allied expeditionary force, whenever it should arrive. Though he began his career in France with an appalling howler,¹²⁸ he retrieved it deftly enough, and was hard at work in Paris by the end of the year.

All told in fact F had had twelve months' industrious working which had implanted in French society several good agents likely to do well; the delusions about CARTE would vanish with the new year. CARTE apart, F's and indeed RF's work so far had looked promising, but had not yet performed much. Von Rundstedt, the German supreme commander in the west, noted after the war that 'During the year 1942 the underground movement in France was still confined to bearable limits. Murders and attacks on members of the Wehrmacht, as well as sabotage, were common and trains were frequently derailed. A real danger for the German troops and a real obstruction of troop movements did not, however, exist.'¹²⁹

The tone of RF's and the BCRA's work in 1942 was still amateurish, even by F's hardly professional standards. Several careless agents precipitated local troubles. It took nearly all the year to set up even a sketchily effective system of overall military command, and this was practically confined to the ZNO. And in London, de Gaulle himself continually raised doubts and difficulties about his secret services' relations with SOE.

One or two examples of carelessness first. The Letac brothers returned to Brittany, quite unobtrusively as they thought, by sea on 3/4 February, rejoined de Kergorlay, and proposed to reinvigorate OVERCLOUD with the new equipment and new ideas they had picked up during their short stay in England.¹³⁰ However, within a week the whole party was under arrest: for the Germans had found a sketch plan of OVERCLOUD in the pocket of a student denounced by *La Chatte* as a member of INTERALLIÉ, had penetrated the Breton organization, and were watching out for the Letacs' return. Of course the young man should never have belonged to both OVERCLOUD and INTERALLIÉ at once: still less should he have committed to paper details of OVERCLOUD he should never have had a chance to find out. But 'these things happen'; particularly when undergraduates essay the tasks of secret service.

These arrests had an interesting sequel. De Kergorlay came back, or appeared to come back, on the air, using another circuit's set, and continued to transmit until early in 1943. It was clear from the start in London that this set was under German control; but it took the Germans several months to realise that the 'radio game' they thought they were playing had in fact

been undermined from the beginning by the British, who were playing a game of their own. However, the handling of this traffic (SEALING-WAX) passed from the hands of SOE into those of other descendants of MIR, where we must leave it, pausing only to notice that Joel and Yves Letac and de Kergorlay did come back from their concentration camp. After the war, de Kergorlay was tried by the French, convicted on clear evidence of having cooperated with the Germans and worked his own set back, and sentenced to lifelong penal servitude and the forfeiture of his whole estate. Yeo-Thomas, hearing of this, was enabled to convince the ministry of justice that de Kergorlay had in fact rendered a valuable service to the allies; for he had said nothing to the Germans about security checks, London had at once spotted that he was under German control, and SEALING-WAX resulted. De Kergorlay's sentence was accordingly much reduced.¹³¹

Another, an even more obvious, indiscretion was committed by Labit, whose FABULOUS we left afloat in Toulouse municipal baths. He came to England by the OVERCLOUD line in January; parachuted back in April; and was soon asked for his identity card in a routine check-up at a zonal frontier crossing at a wayside station south of Bordeaux. He produced two identity cards at once from the same pocket, each bearing his photograph but made out for two different people; this inanity promptly cost him his life. He shot his way out of immediate danger, by pulling an unexpected pistol on his captors; but faced by the tumult of troops assembling to hunt him down, he swallowed a lethal tablet lest he should talk under torture.¹³² Older agents or would-be agents did not make either kind of impetuous mistake. Jean Moulin for example, twice Labit's age and many times the wiser, habitually went on clandestine expeditions accompanied at a discreet distance by a courier who carried his second set of false papers for him, and was ready to hand them over at any awkward turn;¹³³ he had already displayed stoicism in danger, and was yet to display more.

But before glancing at the most important feature of the BCRA's work this year, the welding into an intelligible whole of diverse fragments of internal French resistance, it is necessary to dispose briefly of the other work it did in co-operation with RF section.

Forman of MAINMAST was replaced by Fassin (*Perch, Sif*), who landed with Moulin on the first night of the year. He gave up any attempt to pursue Forman's elaborate directive, and concentrated on establishing a close liaison between London and Henri Frenay's large organization COMBAT, formed late in the previous year by the fusion of LIBERTÉ and LIBÉRATION NATIONALE. Fassin and his wireless operator Monjaret spent all the year in work with COMBAT and in an even more important task: the setting up of a body to direct air operations into the whole of the ZNO. This body, at first known as COPA, soon renamed SAP (*service d'atterrissages et parachutages*), became the principal channel for the delivery of arms to the numerous resistance organizations in contact with RF in southern France, and arranged for many

pick-up operations by which French agents and politicians could travel to and fro between France and England. Fassin was lucky enough to have two first-class pick-up organisers to work under him; Paul Schmidt (*Kim*), who was dropped to him on 3/4 June and worked for sixteen months on end in perilous conditions, and Paul Rivière (*Marquis*), a personal friend who distinguished himself later for his particularly co-operative attitudes towards the inter-allied missions he met. In the ZO a separate body to run the same sort of work, BOA (*bureau d'opérations aériennes*), was set up in the second half of the year by Jean Ayrat (*Roach* or *Harrow*), dropped to one of Schmidt's receptions in July. Without these two staffs, BOA and SAP, the gaullist resistance forces could only have got such few arms as they could smuggle out of Vichy depots or steal from the Germans.

Neither BOA nor SAP could of course do any useful work without an exceptionally elaborate communications system, consisting partly of 'letter-boxes' through which agents and organizations could send them messages, and partly of wireless operators to transmit them. This naturally led, given the apparently inevitable conditions of clandestine work by the French, to difficulties of various kinds with various police authorities. One example may illustrate the sort of trouble people could run into, and the sort of help they could get to find their way out of it. In mid-October Schmidt's wireless operator, G. E. Brault,¹³⁴ was in the middle of a long transmission to London in his digs in Lyons when his landlady put her head round the door and told him that five cars had just pulled up outside. He sent to London in clear the one word '*attendez*'; set fire to all the messages he had not yet destroyed; and when the door next opened, sent '*police*' in clear. He was at once taken off to prison – fortunately for him a French prison, although the Gestapo had illegally taken part in his arrest. One of his guards, a member of LIBÉRATION, had been warned to go to Germany on forced labour. The guard got in touch with Schmidt's girl courier, and at a suitable moment let Brault out of his cell, provided him with a rope which they both used to climb the prison wall, and got away with him.

Pro-allied figures in the French police forces were in fact so numerous that neither the Vichy nor the German authorities could ever rely on what might happen to arrested agents. A lurid example of this was provided about this time in Toulon. One of RF's less successful agents, *Crayfish*, had been parachuted west of Lyons in July with a wireless operator to work the Provençal coast. The operator was arrested in Avignon in September; escaping later, he rashly returned to his lodgings to pick up a large sum of money he had hidden there, to be told by the landlady that the organizer had collected it a few days after his arrest. *Crayfish* himself had then been arrested, on the civil charge of obtaining money by false pretences, by a pro-allied magistrate who had heard that he was spending on his own enjoyment money that there was reason to believe had been given him for resistance purposes. *Crayfish* tried to change sides, and wrote a letter to the Vichy ministry of justice

denouncing various named members of the Toulon police as sympathisers with the resistance. A clerk in the police office through whose hands the letter passed disliked Vichy still more than he disliked any authority in London, and suppressed it.

One other piece of Fassin's work in 1942 deserves mention: it was he who discovered General Delestraint (*Vidal*), a recently retired commander who had the military standing and the presence to make him a suitable candidate for the post for which Moulin at once began to groom him, commander-in-chief of the secret army in France.¹³⁵ One of the BOA'S earliest tasks was to dispatch Delestraint on a short visit to London, where de Gaulle welcomed him and ratified his appointment.

RF's sabotage record this year, though not remarkable, was more impressive than F's. Three strong-arm men called de Clay, Gauden and Bodhaine were dropped not far from Paris on 5/6 May to attack the main Radio Paris transmitter at Allouis near Melun, the French equivalent of Daventry; it was being used to jam RAF signals traffic. They covered thirty miles in three nights, reconnoitred their target, and planted on the night of 9/10 May ten charges on the main pylons. Their previous record had given no indication that they were likely to be successful clandestines; and they moved about the wireless station noisily enough to attract the sentries. They had intended to press the six-hour time pencils on their charges before they cut their way into the station; they forgot to do this, but remembered in time – while under fire – to press them before they left. The time pencils as it turned out were defective and went off after ninety minutes. As they remarked in their report, 'if we had adhered to [our] plan – it would have been: Failure of a Mission and the PILCHARD team in Paradise!'¹³⁶ Some of the DF agents who were in charge of getting the PILCHARDS away through Spain later expressed doubts about whether it was paradise that was their ultimate destination; but at any rate they did the job SOE had sent them to do well enough. They only put Radio Paris out of action for a fortnight; but it was a fortnight when Radio Paris would particularly dearly have loved to make broadcasts, because it coincided with the British landing in Madagascar that so infuriated de Gaulle: Madagascar after all was French, and he had received no advance warning of the operation at all. He expressed himself so violently on the subject that his relations with Churchill, seldom wholly cordial, underwent a further strain, and BCRAM operations suffered accordingly for a while.¹³⁷

The other sabotage missions were less colourful. *Hagfish* was sent to observe the Paris SD, and when last heard of was understood to be co-operating with it. *Garterfish* shared an aircraft at the end of October with two celebrated F agents, Gilbert Norman and Roger Landes; his task was to blow up some transformers near Saumur. RF heard nothing more of him till Yeo-Thomas ran into him in the street in Paris after the war and had his assurance that he had in fact done his work before going home. Two or three other sabotage missions had even less to show.

Some other parties had done badly too. DASTARD, in trouble at the end of 1941, was patched up by Bourdat who arrived by parachute in January; but Allainmat the wireless operator disappeared in March, and Bourdat was killed in action in mid-July. Laverdet escaped from the same scuffle with the Gestapo, with the remaining supplies of money; these he exhausted in buying himself a new identity, and he was unavailable to work again with SOE till the spring of 1944.¹³⁸ The BARTER mission, sent in the previous autumn to attack Mérignac, which had sunk without a trace on arrival, surfaced again for a moment in the spring, only to disappear again. An important mission, GOLDFISH, with two agents called Georges and Montaut, was sent to France by parachute on 28/29 May, to supply FN with the wireless communications that it was urgently demanding; but this GOLDFISH was eaten within a week by the cat of the Gestapo, and it was not until October that Paimblanc (*Carp*) arrived by Lysander to take up GOLDFISH's mission, and establish firm contact between de Gaulle and the PCF. Even so, the communists' security was so tight that any message usually took a month to get an answer.

Two other small RF parties deserve record. Chartier and Rapin (COCKLE) were dropped into the Vendée on 20/21 December; their adventures must be held over to next year. The other party, COD, we last saw digging itself in quietly in central France. It ran into trouble in the spring, and Thomé sent a hectic telegram demanding a Lysander. The RAF sent one, in spite of bad weather, and were furious when they found they had brought back not Thomé at all, but a sub-agent of his called Collin who had no really urgent need to get out of France and no proper training in landing a Lysander. After this incident (JELLYFISH, 26/27 April) the RAF everywhere insisted on much tighter control of pick-up operations, which they refused to conduct except to agents 161 Squadron's own pilots had trained themselves. Collin went back to France by Lysander on 29/30 May to conduct the SHRIMP mission, an attempt to run a gaullist organization in Corsica, which he visited for a couple of weeks himself; he was withdrawn by one of his own Lysander operations – he had been trained while in England – on 22/23 November.

Jacques de Soulas (*Salmon*) was parachuted on 1/2 April to carry out several intelligence tasks for Dewavrin, and to get into touch with a number of formerly eminent politicians to discover what part they would play in resistance; he took three million francs with him and was soon sent a wireless operator. But the weight of the tasks laid on him was too great; by August it was clear he was getting into a muddle. He was told to drop his remaining intelligence work and refer for political orders to Jean Moulin. Lardy (*Skate*), sent in by Lysander with a wireless operator in November, was also told to place himself under Moulin's command.

Moulin and Morandat spent the year reducing the early chaos of internal resistance into some sort of order. Their personal security remained impeccable; and though they co-operated steadily they seldom met.¹³⁹ Morandat's work lay mainly among trade unionists; Moulin's, among intellectuals,

administrators and business men who had turned politician or soldier, or both, under stress of war. They organized widespread demonstrations on May Day, which annoyed the Germans, encouraged the French, and showed goodwill towards the communists. The rest of their work was less spectacular; there was plenty of it, and obstacles to doing it cropped up among resisters and allies as well as from Vichy or Berlin. Frenay for instance looked for a time to the possibility of co-operating with Vichy to throw out the Germans.¹⁴⁰ The Americans meanwhile, through agents in Switzerland, seemed to be trying to buy the adhesion of any resistance movements whose heads were not too ardently gaullist. Moulin, stressing the dangers of 'dissidence among the dissidents' from the existing regime in France, had to talk Frenay round, and then to persuade the three big ZL movements – COMBAT, LIBÉRATION, and FRANC-TIREUR – to testify to the Americans their devotion to General de Gaulle.¹⁴¹

By the autumn the concept of co-ordinated resistance had been pushed forward almost to the point where a national organization could be set up. In October de Gaulle persuaded d'Astier and Frenay, who were then in London, that a military co-ordinating committee should be set up under Moulin's presidency in southern France, to direct the work of the secret army-to-be; and the general then accepted Delestraint, under whom he had once served, as that army's commander-in-chief. Morandat was withdrawn by air for a rest in mid-November; Moulin was to have come with him, but stayed in France to launch the co-ordinating committee; bad weather kept him there another three months. The committee at last met for the first time on 27 November: after ATTLA had proved the uselessness of Pétain's army as a tool against the Germans. (De Lattre alone of that army's senior commanders had lifted a finger against them; and he was quietly arrested.¹⁴²) At this meeting, Frenay secured for himself the post of administrative adviser to the senior but inexperienced Delestraint: hence many future quarrels.¹⁴³

But meanwhile, wherever Moulin and his friends preached de Gaulle, they found believers; from inside France, they could clearly see that he was the only serious leader resistance could put up. In London this was still unclear. Back at the turn of 1941–42 the general, dissatisfied with the independent activities of F section and smarting under various delays – the long hold-up weather imposed on Moulin's return to France will be remembered – threatened in a gloomy moment to wind up his own secret services altogether, and then proposed to take F section over. This brought a reply from the Foreign Secretary with an unexpectedly sharp sting in its tail:

Your letter suggests that you would like to see the British organizations conduct their activities in France exclusively through Free French channels. This, I fear, is a proposal which we could not accept in present circumstances. His Majesty's Government consider it essential for the proper functioning of the British Intelligence Service and Mr. Dalton's

organization that they should continue to maintain contact with any French elements inside or outside French territory through which they find it useful to operate, irrespective of the political allegiance of the persons in question. It would not, we fear, be prudent to rely, for the purposes now in question, on the assumption that the National Committee enjoys the adherence, open or secret, of a very large majority of French citizens.¹⁴⁴

Even Gubbins remarked, a couple of days later, 'It is clear that we cannot build up a proper secret army in France under the aegis or flag of de Gaulle; that we must do through our independent French [i.e. F] Section, until such time as a combination is practical politics'.¹⁴⁵

Much more strongly anti-gaullist views were held elsewhere in the British high command; Thackthwaite recorded that on 10 January the head of the intelligence service wrote to CD 'that Giraud would be more popular than de Gaulle, and that de Gaulle had not a great following but only a symbolic value'; this in reply to an assertion by F section, 'which rightly insisted that de Gaulle was the only possible head'.¹⁴⁶ A run of dinner parties at various levels did little to make things more easy; such trivia as d'Astier's escape from France on an F operation instead of an RF one made them more difficult, and Madagascar made things worse still. The CIGS recorded on 12 May that 'I do not ... consider that General de Gaulle is in a position to bring in the French army in Unoccupied France on our side. On the contrary, I consider that any attempt to link up the Free French with action by the French General Staff ... would be disastrous'.¹⁴⁷ A co-ordinating committee, jointly staffed by de Gaulle's headquarters and by F and RF sections, was projected by d'Astier, but shot down by de Gaulle;¹⁴⁸ for de Gaulle consistently refused to admit the right of F section to operate without his leave on his country's soil, and would not acknowledge its existence by having his staff sit with its staff round one table. This was the basic disagreement between him and SOE; and his personal standing as an outlaw made him more insistent on the point, not less. Resolute intransigence was the only attitude his keen sense of honour allowed him to adopt; but it did not make for any sort of smooth working. André Philip's appointment to his embryo ministry of the interior, on the other hand, did some solid good, by relieving the strain on Dewavrin and simplifying the structure of the Free French secret services;¹⁴⁹ Dewavrin also may have been glad enough that a project to send him to France to do Moulin's work for him was cancelled. He went later, with better effect. Philip only just arrived in time, early in August. For at the beginning of that month Hambro told Morton that his patience with Free French chopping and changing was running out,¹⁵⁰ and Gubbins was minuting to him that 'de Gaulle is busy furthering his political ends ... [his] agents do not appear to be making any attempt to fulfil their primary role of executing an active sabotage and subversion policy'.¹⁵¹ *Per contra*, Billotte on 7 August

and Dewavrin on the 12th presented SOE with long indictments, in which they alleged that bad faith and sharp practice had hindered various RF operations.¹⁵²

These protests were known in SOE to have no solid foundation in fact; the hindrances had come from bad weather and bad luck, SOE took the protests to indicate a further attempt by the gaullists to secure the independence of their secret service activities from any sort of British control, and the matter was promptly referred to the War Cabinet. The Cabinet reaffirmed on the 20th its previous decisions that SOE was to remain 'the co-ordinating authority of all secret preparatory action in France', but recommended 'closer collaboration' with de Gaulle. This led to a further round of dinner parties; and to a fresh proposal for a co-ordinating committee, which succeeded. The new body contained only Grierson the head of AL and Hutchison the head of RF, on the SOE side, so the gaullists could send a representative to it without loss of face, for it included no member of the abhorred independent French section.¹⁵³ All these formal points of staff duty detail will seem trumpery to someone who reads them sixty years on; but to proud and gallant Frenchmen still smarting under the disaster of 1940 they involved points of honour of supreme significance. It was as well that they were in the end amicably settled, before ATILA and TORCH set all the work of French resistance in a new context.

IX

Middle Game: 1943

The year 1943 was altogether more successful. The tide of the European war had just turned, at Stalingrad and Alamein; conformably, the tide of SOE's affairs in France also began to rise. During these twelve months F, RF, and DF sections were all in difficulties with the Gestapo, which were survived easily enough by DF but which left F's and RF's principal field organizations alike leaderless. However, repairs were prompt; by the year's end both offensive sections had teams that covered the country effectively and knew what to do; moreover, the year's record in actual sabotage was striking. For the first time SOE could claim that it was making the sort of impression on the enemy high command in France it had been set up to achieve: nevertheless, it was during this year that the most important attempt was made by other services to break up SOE altogether and subordinate it to them. Von Rundstedt recorded 1943 as 'a serious turning point in the interior situation of France ... The organized supply of arms from England to France became greater every month', and his headquarters was given 'an impressive picture of the increasing danger to the German troops in the territories of the West. ... Not only the murders and acts of sabotage against members of the Wehrmacht, against Wehrmacht installations, railways, and supply lines were on the increase, but in certain districts organized raids of gangs in uniform and civilian clothes on transports and military units multiplied.' And by the end of the year 'It was already impossible to dispatch single members of the Wehrmacht, ambulances, couriers or supply columns without armed protection to the 1st or 19th Army in the South of France.'¹

The executive received its main directive from the chiefs of staff on 20 March:² a directive that was one of the milestones in SOE's history and at last established its position firmly in Whitehall, for its purport was circulated round the exiled authorities in London, and settled many squabbles between them and various British departments. The vital sentence read; 'you are the

authority responsible for co-ordinating sabotage and other subversive activities including the organization of Resistance Groups, and for providing advice and liaison on all matters in connection with Patriot Forces up to the time of their embodiment into the regular forces'. Resistance groups were defined as 'organized bodies operating within enemy occupied territory or behind enemy lines', and patriot forces as 'any forces which may be embodied in areas liberated by our armies'. SOE's activities were to be 'concentrated to the maximum extent' in support 'of the general Allied strategy for the war', laid down by the joint chiefs of staff on 19 January. This was to concentrate on defeating Germany in 1943, through the Sicilian invasion, 'the heaviest possible bomber offensive against the German war effort' and 'such limited offensive operations as may be practicable with the amphibious forces available'; efforts in the Pacific were to be played down accordingly. 'The sabotage of industrial objectives should be pursued with the utmost vigour', SOE's directive from the British chiefs of staff went on; 'sabotage of communications and other targets must be carefully regulated and integrated with our operational plans'. Guerilla activities were not at this stage much encouraged by the chiefs of staff, and the section of their directive that bore specifically on France was frankly woolly. Their advice to SO boiled down to keeping in touch with CCO and hammering submarines as best he could. Six areas were picked out by the chiefs of staff for particular attention by SOE this year, and placed in an order of priority in which France came third, after Mediterranean islands and the Balkans.

Although the chiefs of staff were not enthusiastic about guerilla work in France this year, they had appointed on 14 December 1942 an *ad hoc* committee on equipment for patriot forces, to review and report on the quantities of equipment required and the methods of its distribution. The committee produced a final report at the end of March in which they observed that 'sabotage material and weapons in the hands of Resistance Groups within the enemy's lines are likely to pay a relatively big dividend and could make a large contribution to the enemy's military defeat'; but emphasised strongly that 'unless present delivery facilities are considerably increased, full value will not be obtained from Resistance Groups at the crucial moment'. The paper included an SOE estimate that the ultimate strength of French resistance groups would be 225,000 and that they had already reached 175,000 by the end of 1942. These figures can have been based on nothing but inspired guesswork. But it was becoming clear that, as Selborne reported to the chiefs of staff on 24 April, 'the tide of resistance is mounting steadily in France. Sabotage is widespread and, to a large extent, under SOE control; there is no doubt that it is already causing grave embarrassment and difficulties for the Germans and for the Vichy Government, and is helping to rally the people against the enemy ... There is no doubt that, provided adequate supplies can be furnished, support of a very effective kind can be given to regular military operations'. This of course precipitated

a brisk discussion about the availability of aircraft to keep SOE's resisters supplied. As the joint planning staff remarked on 10 June, 'although it may be possible to defer a full-scale revolt to the right moment SOE cannot ... restrict their support. It is the very nature of the organizations they establish that they should multiply themselves and it is in every way desirable that SOE support should keep pace with this growth'. SOE and bomber command collided head on in this dispute, Harris maintaining that the joint chiefs of staff's directive of January must give him priority over SOE, and Selborne maintaining in effect that Harris and his bombers could not win the war by themselves, and that a diversion of resources to SOE which from bomber command's point of view was comparatively trivial, might well produce a decisive turn to the military situation when the time came to invade Europe. This already complicated discussion was complicated further by competing demands within SOE for aircraft to supply resistance forces in the open guerilla fighting in Yugoslavia as well as in the more clandestine conditions of western Europe. We have seen already³ part of the high-level discussion on this subject. In the end, there was a slight immediate increase in the special duties aircraft available in western Europe, which from SOE's point of view was inadequate to supply the continuing demands from France. In the course of this debate, on 26 July, Hambro drew the chiefs of staff's attention to the number of requests for air resupply from the field left unfulfilled at the end of each moon period: in March, April, May and June of 1943 these amounted to as many as 102, 120, 55 and 54 sorties respectively, about nine-tenths of them for France. Next day the chiefs of staff agreed 'that we should support SOE activities in the Balkans as far as possible and at the expense, if necessary, of supply to the resistance groups in Western Europe'.⁴ Selborne persisted, and took the matter to the defence committee. He told them late on 2 August that resistance was booming and needed to be fed with arms; if they were not 'continuously stimulated by the supply of arms, and ammunition these movements would die' and much good work would go for nothing. Portal in reply made it clear that it would be hard to give SOE more than twenty-two aircraft in western Europe as a rule, and recommended that the subversive organizations should be brought more directly under the control of the chiefs of staff: this indeed had been recommended by the joint intelligence committee the previous day.⁵ Selborne reiterated that with only twenty-two aircraft he could not carry out his tasks in western Europe. The Prime Minister 'emphasised the immense value to the war effort of stimulating resistance amongst the people of Europe' and in discussing reprisals used the significant text that 'the blood of the martyrs was the seed of the church'. The upshot of all these discussions was that bomber command was to do supply work for SOE 'subject to the direction on priorities as decided by the Chiefs of Staff'. Selborne's right of appeal to the defence committee if the chiefs of staff directed against him was specifically provided for. In fact Harris fended off for several months more

any extensive participation by his squadrons in SOE's work. A more useful long term result of this dispute was closer co-operation between SOE and the chiefs of staff, and more frequent attendance by CD at chiefs of staff meetings.

The QUADRANT conference at Quebec in August did not carry SOE's affairs much further forward. Portal urged with a vehemence that Harris would strongly have approved the importance of POINTBLANK, the current Anglo-American strategic air offensive plan. The Americans took note that the supply of resistance groups in France was a British and not an American commitment; and the final report included a proposal for a diversionary landing in southern France as part of the OVERLORD plan, supported if possible by air-nourished guerilla operations. Roosevelt, taking a momentary detailed interest in this subject, indicated that he felt that guerilla operations could be initiated in south central France as well as in the Maritime Alps; otherwise QUADRANT'S affairs lie outside our scope.

On 5 October the chiefs of staff decreed that COSSAC, the chief of staff to the as yet unknown supreme allied commander for the invasion of north-west Europe, was to 'exercise operational control over SOE/SO's activities' in his area; but General Morgan's control was not to extend beyond broad general directions.⁶ For the time being this change was purely formal; but it will hardly be necessary to refer to the chiefs of staffs' directives again, as COSSAC and then SHAEF acted as their intermediary where France was concerned. And by the time the change had been made, the main controversy about SOE's autonomy had been settled, at a meeting of ministers held by Churchill on 30 September. They agreed that '(i) SOE organization will preserve its integrity ... (ii) the main policy for SOE will be settled in London between the Foreign Secretary and the Ministry of Economic Warfare, reference being made, if necessary, to the Prime Minister or War Office ... (vi) the chiefs of staff will be kept in close touch with SOE operations on all levels and will have a right to express their views to the Minister of Defence on SOE matters if at any time they consider this to be necessary'.

On the French side, the efforts of internal and external resistance alike – SOE's included – were naturally hampered by the quarrel between Giraud and de Gaulle that raged all through the year. Though both generals were professional soldiers, they stood for opposite objects: Giraud for the sober continuation of established order, with a due reverence for Pétain; de Gaulle for a revolutionary shift away from the old system and the old regime. Giraud seemed to hold the stronger hand, with three aces in it: American support, the actual command of much larger formed bodies of troops – the vichyste army in north Africa – than the gaullists could yet aspire to; and the allegiance of ORA, the apparently powerful resistance organization founded in France by the Vichy general staff on the structure of the dissolved 'armistice army' 100,000 strong. But de Gaulle, a much more skilful player, was able to call trumps, and to trump all Giraud's aces; for the mass of

resisters in France loathed Pétain almost as much as they loathed Hitler, and sought a genuine social revolution as the prize for evicting their occupiers.⁷ And the high command of SOE thought little of Giraud, while de Gaulle was clearly a man of force, whom SOE could respect and admire, in spite of the difficulties that sometimes attended on working with him; so SOE as a rule assisted him in winning. For a few hours in May, disaster seemed to impend for de Gaulle: Churchill, on a visit to Washington, was persuaded by his hosts that the best thing to do with the general was to drop him, and cabled to the Cabinet in London accordingly. They replied at once, urging him to reconsider;⁸ and Anglo-gaullist co-operation survived.

Let us now come down from the staff stratosphere and consider at a country section and circuit level what SOE's staff and agents managed to do in France this year to implement their directives. RF may conveniently be dealt with first. It spent much of the year working with the BCRA on the task of co-ordination; but their incessant attempts to centralise resistance had an unintended effect: they only made it simpler for the Germans to break it up, and the standards of security of some of RF's senior agents made the German's work more simple still. Delestraint for example, the retired general who commanded the gaullist secret army, was so little skilled in the ways of clandestinity that when he reached a safe house in Paris but could not enter it, because he could not recall the password, he went off to a nearby hotel and took a room there in his own real name: an incident that led directly to his arrest.

More wily clandestines entered the gaullist sphere this spring, for the paradoxical effect of the Darlan affair was to drive de Gaulle and the communists closer together; both stood to lose more from Anglo-American co-operation with Vichy ministers than they stood to lose from co-operating with each other. On this unstable base, Fernand Grenier came to London as the accredited representative of the PCF in early January, and settled down to work for his party.

Jean Moulin was brought out of France in February for a short rest. He alone of the men who joined de Gaulle had the capacity to supplant him; but he was a loyal gaullist and worked under him instead, to his own destruction. He parachuted back into France at the end of March, still as de Gaulle's delegate general, to implement an important decision: the setting up, under his own presidency, of the Conseil National de la Résistance, the senior body inside France representing the strategic and political desires of external resistance.⁹ The principal creators of the CNR, besides himself, were Dewavrin the head of the BCRA and Pierre Brossolette, a strong libertarian socialist with a scintillating intellect, a sarcastic tongue, a ready pen, and a bold heart.¹⁰ Brossolette had resisted fascism stoutly since the time of Munich; he reached London in the summer of 1942, after two dangerous years of work at underground propaganda, and became Dewavrin's deputy. Late in January he returned to France, where he was joined a month later by Dewavrin

(mission ARQUEBUSE). Dewavrin was accompanied by Yeo-Thomas of RF staff as a demonstration to the French that there was no great gulf fixed between the BCRA and the British. Yeo-Thomas was as strongly gaullist as either of his companions; he had lived most of his life in France – latterly, working in Molyneux, one of the great fashion houses – and was perfectly bilingual.¹¹ Nobody thought the presence of an Englishman on a French political mission odd; indeed he soon reported that ‘The people I have met all expressed great satisfaction that a British officer should have been sent to see them and I think the moral effect is excellent’.¹²

The three friends’ main aim was to get the big movements in the northern zone to accept central direction for their military activity, as the big movements in the south did already through the gaullist committee of co-ordination. Pursuing this object, they saw the heads of the OCM, CEUX DE LA RÉSISTANCE, CEUX DE LA LIBÉRATION, the nascent LIBÉRATION-NORD and FN; ‘all of which’, as Yeo-Thomas put it, ‘have a para-military character, but no arms’.¹³ The chief difficulty the visitors had expected to encounter was political; to their delighted surprise, they discovered that ‘Political parties ... are a thing of the past, they are considered as being responsible for the collapse of France, and will never be revived’, while ‘General de Gaulle is the undisputed and indisputable head, both moral and material, of French resistance. The ZO is 95 per cent gaullist’.¹⁴ Dewavrin proposed the formation of a strictly military secret staff, which would receive its directives from de Gaulle in London in accordance with current allied strategy; the movements all agreed that they would accept this staff’s orders, and would pool such resources as they could assemble to carry these directives through.

Moulin and Delestraint then came on the scene, and at a risky but necessary general meeting on 12 April saw, round one table, the ARQUEBUSE mission and spokesmen for the five main ZO movements.¹⁵ The agreement made with Dewavrin was on the whole confirmed, but FN’s representative Villon raised a difficulty. The other movements were happy to wait for an allied invasion before they started fighting, though they all insisted strongly that there must be an invasion in 1943; otherwise, the STO would have sucked France dry of fighting men. Yet FN regarded itself as already in action, claiming to kill about 550 Germans a month.¹⁶ This policy of activism brought in many more recruits – ‘no more real communists than I am a Chinaman’, as Yeo-Thomas put it¹⁷ – than it lost in casualties, and was not one that FN was ready to drop.

Faced with this resolute opposition, Moulin hedged; the meeting broke up without arriving at a decision.¹⁸ Nor was one reached in his lifetime. He was not yet fully attuned to work in the former ZO, where resisters had long been tougher, more militaristic, and more ready to take orders as orders and not as a basis for argument than were their more politically-minded fellows in the south. Moulin acquiesced for the time being in FN’s continued tip-and-run raiding, and concentrated on a grander project, the fusion of the

northern and southern military co-ordinating committees into a single CNR. This he shortly achieved.

There is no need to record here more than the bare fact of the CNR's constitution at the end of May, and the tragedy of its collapse a few weeks later; for some gaullists seemed unable to understand what security meant. Dewavrin and Yeo-Thomas were once the horrified witnesses of a shouting-match between Brossolette and Moulin, usually so meticulous, yet each overwrought by too long a spell underground, and each accusing the other – reckless of the Germans who might be in earshot in the neighbouring flats – of trying to build up his personal resistance following instead of pursuing the cause of France.¹⁹ A few weeks later, in the second week of June, the Gestapo collected Delestraint when he was changing trains in the metro; and on the 21st, at a doctor's house at Caluire a northern suburb of Lyons,²⁰ a dozen leading gaullists, Moulin included, were caught as they were assembling for a meeting.²¹ One man, René Hardy, escaped immediately, and was subsequently acquitted of having betrayed the rest, who were taken to Paris. Jean Moulin was so barbarously treated by his original captors that he was dead within a fortnight, taking all his secrets with him. One young committee member was left behind in Lyons, Raymond Aubrac; his wife, over six months gone with child, personally took part in his rescue from a Gestapo lorry in the heart of Lyons, a brilliant cutting-out operation of her own design; they were soon brought out by air.²² But this left all the pro-gaullist movements leaderless.

Moulin, like other great men, had taken no care to train on a successor to himself; moreover, he had refused to delegate much of the work he had done. He had preferred to keep all the threads in his own hands; partly for security's sake, partly because he knew he at least could manipulate them properly. This sometimes hampered his cause, for there were bickerings and resentments among his junior colleagues before his arrest. When he was captured, he imposed on himself the appalling burden of dying silent: a burden his patriotism enabled him to sustain, in spite of all the tortures Barbie's thugs inflicted on him.²³ But his death left chaos behind, where order was most necessary; at the centre.

The Caluire arrests had been of leading men; men of courage and weight, none of whom lightly betrayed anything he knew. The gaullist delegation's wireless, secretarial, and liaison apparatus remained – though headless – intact, and in working order. One of the secretaries tried to keep things running, and at once informed London of the disaster. In mid-July, Dewavrin proposed that Brossolette and Yeo-Thomas should return to France to discover just how much damage had been done, and to rebuild as much of the fabric of command as they could (mission MARIE-CLAIRE).²⁴

For various reasons, the mission, took over two more months to mount. Among these reasons was certainly one of the worst quarrels between SOE and the gaullists, which raged in August. All SOE's high command from

Hambro down to Brook and Hutchison were insistent that the gaullists must decentralise, must prevent any more Caluire catastrophes by keeping the general direction of their movement right away from any possibility of Gestapo interference, outside France altogether. The French nevertheless handed in for transmission a telegram to the field, accompanied as usual by a copy in clear, in which Brook noticed that Morinaud and Mangin (General Mangin's son) were designated as *chefs de zone*, each to control half France. He objected to this; the French resubmitted the telegram, differently encoded, assuring him the offending sentence was now missing. A suspicious-minded staff officer noticed both coded telegrams had the same number of groups. SOE's deciphering section was called in, and in an afternoon's intensive study cracked the French code; the content of the two telegrams turned out identical.

This put everyone's back up. The French believed Brook had simply referred to the copy of the French codes which he kept sealed up in his safe in case of emergency. Brook was barely aware that he had taken this document over, with much else, when he became D/R; certainly it slipped his mind at the crisis, and in any case he could hardly admit that he had got it to the deciphering staff he had just been working so hard.²⁵ The philosophically minded Mr Marks, head of the code section, had the disagreeable task of proving to the French that Brook had not cheated by going round to Duke Street, getting them to encode a message on any subject they chose, and then breaking the code under their astonished noses.²⁶ This did not endear the British to the French, any more than the original French appearance of duplicity endeared the French to the British; and for some weeks of strained relations, as Thackthwaite recorded ruefully, the junior officers who were trying to look after the men in the field while their superiors squabbled had to do their indispensable business in bars and at street corners, because they were officially forbidden each others' offices.²⁷

Common sense won through before long; but the delay imposed on the MARIE-CLAIRE mission brought serious results. While the London staffs disputed, the gaullist delegation in France was in the hands of the young Serreules (*Sophie* or *Scapin*), a former ADC of de Gaulle's, who had arrived by parachute in mid-June. Neither he nor his close companion Jacques Bingen (*Meeker* or *Cléante*) was equal to Moulin's role. Bingen had joined the Free French in London in July 1940, the only shipowner to do so; for over a year, he looked after the Free French mercantile marine's interests in the ministry of shipping, but fell out with Admiral Muselier and joined de Gaulle's headquarters.²⁸ Both were comparative innocents in the secret world. Yeo-Thomas and Brossolette had a first meeting with Serreules on 21 September, two days after their own arrival by Lysander, at a flat in a fashionable part of Paris; they were at once alarmed by his over-confidence and lack of security. Before the end of the week the Germans had arrested him.

By sheer plausibility, he talked his way straight out of their hands; but left his identity card behind, so they raided his flat. There they found four months' W/T traffic with London in clear, and a list of fourteen proposed members of a reconstituted CNR. Many more arrests followed.²⁹

This incident made confusion a good deal worse confounded; and the SD pursued the gaullist high command in Paris as hard as they could for some weeks. In the last three weeks of October 'neither Brossolette nor I', wrote Yeo-Thomas, 'thought we would get away with it. In spite of all our efforts and the energetic tightening up of security all through our organization the tempo of arrests seemed to accelerate, it was like a land-slide',³⁰ Once or twice agents were arrested from whom they had barely parted an hour before. Yeo-Thomas had strong reason to suspect that some prisoner's indiscretion had betrayed his own real identity. Once on rising in the morning he noticed a curtain twitching across the street from the house he was staying in and inspected the street more closely. 'In addition a gentleman wearing a greenish-beige raincoat was half hiding round the corner with his eyes glued on my house. I therefore promptly vacated the premises by a back door having to leave some of my kit behind, I advised *Sophie* of this and warned him that I had left my house because it was dangerous – in spite of this, about forty-eight hours later he held an important meeting there!'³¹ In another house, also believed quite safe, Yeo-Thomas dined with Brossolette – they did their best to avoid restaurants, as too dangerous;³² after dinner they felt uneasy, and decided to leave at about eleven. The Germans arrived in the small hours of the next day, and arrested their hostess.³³ 'A point illustrating Gestapo thoroughness was made apparent as [she] had a little white dog that barked at strangers and made a fuss of friends. This dog was taken out by Gestapo men and promenaded through adjacent streets in an effort to identify possible friends of the owner.'³⁴

A further extract from the same report carries the authentic tone of clandestine excitement:

On. four occasions I was trailed but threw off my followers. The first time was on the occasion of an appointment with *Oyster* [Pichard] in front of the Madeleine. Neither of us was followed prior to meeting and we walked off together and noticed a man who had been standing nearby, seemingly with nothing to do, fall in about 20 yards behind us. We ascertained that he was really following us by making a few detours, and having made sure that he was definitely interested we made tracks back to the Madeleine Metro Station arranging to part very suddenly; *Oyster* was to dive into the Metro and I was to cross rapidly over to the Rue Royale, thus forcing our follower to choose between us. Our manoeuvre was carried out and the follower tacked on to me. As I had an hour to kill I took him for a fast, long walk – he was wearing a heavy grey overcoat and I am sure he must have lost some weight. Having given him a good run for his money I dashed in the Printemps and I

went down to the basement whilst he was being slightly held up by a group of shoppers and having gained a lead took one of the service passages reserved for employees thus getting rid of my persistent follower. On two other occasions I was picked up after contacts, but both times threw off my men very quickly, one by using the old trick of taking the Underground, getting out at a station, walking along the platform and suddenly jumping back into the train at the last minute. On another occasion Brossolette and I had an appointment on the Boulevard Haussmann with *Necker*. We met him and noticed that he was being trailed by no less than three men. He had not realised it and would not believe us so we proved it by walking fast, turning down Rue d'Argenson and again into Rue de la Boetie and waiting just round the corner in a big arched doorway; one by one our three followers came tearing round the corner and left us in no doubt as to their intentions. We then doubled on our tracks and made rapid plans to dodge our unwelcome friends. We sent *Necker* off on his own into the Rue Laborde before the three sleuths could come back on us – Brossolette and I then walked briskly towards Place St Augustin and agreed to separate and meet an hour later at the corner of Avenue de Villiers and Boulevard de Courcelles. As we arrived at Place St Augustin we saw two velo-taxis and each jumped into one thus leaving our followers with no means of catching us up.³⁵

Yet amid the excitements MARIE-CLAIRE did manage to do some real work. Its two members considered whether they should cease all their activities and lie low; or, 'on the contrary knowing the risks involved, intensify our actions and get as much as we could tied up before being ourselves probably caught.' They chose the more dangerous course; because it was their duty to do so, because a refusal to be disturbed by the Gestapo's probings would hearten their companions, and because 'the margin of safety was such that we might as well face the additional danger resulting from increased activity'.³⁶ Their first achievement was to settle a conflict that had been raging when they arrived between the BOA and the main ZO resistance movements, a conflict that arose from the confusion that had followed the Caluire arrests. The BOA was receiving and stocking arms; the movements wanted them distributed; but no effective liaison between these two sides of gaullist resistance existed any longer, and each felt themselves outcasts. Yeo-Thomas and Brossolette, short-circuiting the delegation staff, brought the two sides together and sorted the difficulty out.³⁷ Secondly, they succeeded in checking Serreules' tendency to try to follow Moulin's example and hold all the reins of the resistance chariot at once. At an angry meeting on 27 October, Yeo-Thomas was able to convince the ZO military co-ordinating committee that it could not exercise command, as Serreules wished, over the various local gaullist leaders of resistance (DMRs); in future the DMRs were to be left to receive their orders direct from the BCRA. This could easily be shown

to be necessary on grounds of safety. Morinaud (*Hussar*), the coordinating committee's nominee as head of the secret army in the northern zone, had been arrested – and had gallantly swallowed his lethal tablet – just after MARIE-CLAIRE'S arrival. Had he been the channel of communication between London and the DMRs that many senior gaullists desired, his arrest might have had even direr consequences, and would have left the regions powerless. Moreover, with arrests going on at the current rate, London was obviously not going to inform anyone in France of more than a necessary local minimum about strategic policy.

Yeo-Thomas carried this main point with the help of Lenormand, of CDLL, and of *Joseph* of FN, both of whom impressed him as thoroughly able and competent clandestine leaders; he tried indeed, though without success, to arrange for *Joseph* to pay a short visit to London. As happened at about the same time among F's PROSPER contacts, the communist organizations who were in touch with the threatened gaullist groups seemed to be much the most immune from trouble; because they took incessant, unrelenting, care about security. Their greater fitness for survival in times of storm naturally increased their proportionate share in the surviving ranks of the secret army.

Communist policy was helped also by a political consequence of the Caluire arrests; a disjunction of the gaullist delegation from the CNR. Jean Moulin had headed both; Serreules his successor *ad interim* seemed unfit to head either; and to de Gaulle's annoyance the two bodies were separated. The chairman of the reconstituted CNR was Georges Bidault, a young catholic member of COMBAT whom Moulin had placed in charge of the *Bureau d'information et de presse* (BIP) he had set up in April 1942. The BIP was a clandestine press agency, charged both with circulating allied propaganda in France, and with keeping the allies informed of resistance activities.³⁸ Bidault had conducted its affairs with discretion and success, without antagonizing any of the resistance movements; among their leading members he was well known and well liked. Aron's opinion of him is worth quoting:

Bidault, indeed, had peculiar qualifications and equally peculiar qualities. He would appear to have been precisely the man required to keep the rivalries in the internal Resistance alive by the double process of, on the one hand, preventing an open row and, on the other, ensuring that the rivalries were never resolved. His singular qualities enabled him to play the delicate part of an umpire who never made a decision; while even his faults contributed to his being tolerated by both sides at once.

The fact was that Bidault, a writer, an intellectual, an orator, a party leader and an honest man, could never wittingly play the Communist game; he was too loyal and sincere for that. And, indeed, he frequently opposed it. Nevertheless, he was subject to the sudden intoxication of some plan, some bright idea, which blinded him to the precise significance of impending events and to the real characters of the men who embodied them. He combined in his nature the attributes of both the glow-worm

and the moth. He glowed and was dazzled by his own light; his thought buzzed and fluttered about itself till he was unable to see the issues. Here clearly was the man the [PCF] required to turn the majority of the committee if not red, at least pink . . .

With Bidault's election to the presidency of the CNR, the organization, without being actually under Communist control, nevertheless seemed no longer able to oppose the [PCF] openly.³⁹

In fact, only one more full meeting of the CNR was ever held, till after the liberation. This meeting, in Paris early in December, confirmed the composition of the council: one member each from the eight principal resistance movements (FN and the FTP managing each to count as one); one from each of the communist, socialist, radical, Christian democrat, democratic alliance, and federated republican parties; and one each from the CGT and the CFTC.⁴⁰ Though it met so seldom the council nevertheless got through a great deal of business in its fifteen months in clandestinity: much of it conducted purely on paper; some of it in meetings of sub-committees; and some in separate bodies, set up to act for it on special subjects, such as the comité général d'études which examined the existing and future structure of French civil administration.⁴¹

Properly alarmed, for the most part, by the disaster at Caluire, the council's necessarily quite numerous staff of couriers and secretaries learned to take special care to keep out of the Germans' way. The presence of communists on the council ensured that the secretariat could get sound advice on this sort of technical point. The communists' main immediate interests lay in promoting military action; on a longer term, they favoured building up the CNR into a body which could eventually supplant de Gaulle's committee, and seize power itself when the moment of liberation came. A pliant chairman of the CNR, who did not add to his office the authority of being the gaullist delegate-general, suited their book. But these manoeuvrings, though matters of central interest to French politicians, lie on the margin of our subject, of SOE in France; for SOE, a British government organ, necessarily operated as a part of external, not internal, resistance. From SOE's angle of sight, the delegation sometimes bulked quite as large as the CNR. In one respect, it could occasionally bulk as large in France also; for the delegate had the power of the purse, and only through him could the main resistance movements receive the large sums of money they needed to keep going.

Bingen acted for a few weeks, from his arrival in mid-August, as delegate *ad interim*; but from 15 September the delegation's affairs were entrusted to Emile Bollaert (*Géronte* or *Baudoin*). He had been a prefect, who had refused to serve Vichy; he was a firm and respected administrator; but he knew little of the gaullists and nothing of the ways of underground life and warfare.⁴²

Brossolette spent some weeks guiding and advising him; while Yeo-Thomas made some inquiries into the nascent maquis, under the experienced eye of

Michel Brault. Yeo-Thomas had a macabre journey back to Paris from Lyons, for over tea in the restaurant car he found himself having to sustain a conversation about the black market with Barbie; knowing that Barbie was head of the Lyons Gestapo and a dangerously intelligent officer, though fortunately ignorant that this was the man who had had Jean Moulin battered to death.

Yeo-Thomas was then recalled to London; Dismore had just taken over RF section, and could not yet get on without him. The journey back, by Lysander from a field not far from Arras, was as full of incident as MARIE-CLAIRE'S early days in France had been. Just before Yeo-Thomas left Paris, a personal friend entrusted him with a suitcase to take back to London; it contained a six weeks' accumulation of reports, of equal urgency and secrecy, from the PARSIFAL intelligence circuit which had just lost to the Germans all its wireless operators, and hence all its means of getting a Lysander quickly. Yeo-Thomas disposed of this dubious burden on the train – he travelled first class by express – by befriending and bribing a batman, who put it at the bottom of a pile of German officers' luggage which the customs officials did not bother to search. Bad weather held him up for three days; part of which he had to spend in a return journey to Paris – by slower trains, clutching his suitcase and hoping no one would ask to look inside it – to warn Brossolette that an SOE contact Brossolette was about to meet had been arrested. Brossolette stayed in Paris to work with Bollaert, and to pursue MARIE-CLAIRE'S still incomplete inquiries into the workings of the secret army. Yeo-Thomas was back in Arras on 15 November, and heard at lunch-time over the BBC that he was to leave that night.

The ground was twenty miles from Arras; during his journey to Paris, a German division had arrived in the neighbourhood and encamped on most of the area in between. Even Deshayes (*Mussel* or *Rod*), the BOA organizer of the pick-up, one of the most effective men in that effective body, was dismayed; the difficulty was surmounted by Berthe Fraser. She was one of the great resistance heroines, a middle-aged Frenchwoman with a British husband; she had been helping escapers and saboteurs since 1940. She worked impartially for any French or British organization that needed her; arranging safe houses, storing explosives, noting German troop movements, escorting escapers, all tasks that came her way and were promptly handled. As she was a 'natural clandestine', not a Beaulieu product, she cared nothing for London's careful compartment systems; as she was enormously brave, she took risks without number. She recalled that there was a graveyard not far from the landing-ground, and secured a posse of undertakers' mutes – tall hats, black scarves, and all; a closed motor hearse; enough petrol; and a coffin. The PARSIFAL mail was stowed in the coffin; Yeo-Thomas and another passenger, armed with stens, were concealed beside it in the hearse, which was well laden, with flowers. The undertakers drove to the graveyard undisturbed, for no one sought to search a funeral procession. By nightfall the

passengers and the mail were under heavily armed resistance escort in a safe farm near the landing-ground. There was no hitch.⁴³ But flying weather then closed down, leaving Brossolette marooned.

Compared to these excitements in the sphere of command, little of the work of ordinary agents, such as the COCKLE party enjoying themselves in the Vendée, or Ayrat, Schmidt, and Rivière engaged in the deadly dangerous routine of Lysander and Hudson operations, can command notice; though among several eminent air passengers General de Lattre de Tassigny is worth particular mention. He was collected by Verity on 21/22 September from Burgundy.⁴⁴

But one party does deserve special notice; ARMADA. The most remarkable instance in France of sabotage directed to serve a strategic end was provided by this mission; two pairs of formidably bold and able men disrupted water transport through north-eastern France at just the period when the Germans had most need of it. They needed it to move small craft – E-boats and miniature submarines – from North Sea to Italian ports, to counter the successive allied landings at Reggio, Taranto, Salerno, and Anzio. ARMADA'S activities produced a brief but total stoppage in this traffic; the Salerno and Anzio landings might either or both of them have been costly failures instead of marginal successes, had the Germans had in time the equipment that ARMADA delayed. As a useful bonus, these RF canal demolition parties also sank some scores and stranded some hundreds of barges carrying goods for the German war machine, and attacked the cannon factory at Le Creusot in passing. The damage to Le Creusot was incidental; it arose from a sub-operation called SLING, an onslaught on a score of electric power and pumping stations conducted with equal verve and success in August and September by the marseillais Basset and his Burgundian mate, Jarrot, the almost legendary *Marie* and *Goujon*. Accident threw them together: they were childhood friends, and found themselves living on either side of the demarcation line near Lons-le-Saulnier, across which they began by organizing a safe passage.⁴⁵ Neither wire nor sentries ever seemed to keep them out of places they wanted to enter; their bombs always went off, when and where they wanted; and they moved so fast that neither the French nor the German police ever quite caught them, though once at least the saboteurs had to rely on a well-thrown hand grenade to extricate themselves from their pursuers.

The first canal attack was made on the Gigny *barrage*, a complicated dam and lock on the Mediterranean side of Chalon-sur-Saône, where the Germans had an E-boat factory. Marcel Pellay (*Paquebot*), specially briefed and equipped, for this task, was dropped on 22/23 July. He made contact at once with Boutoule (*Sif B*), a London-trained saboteur who worked with the COMBAT organization in Lyons, and with Henri Guillermin (*Pacha*) the sabotage leader⁴⁶ for the Saône-et-Loire. The three of them made a completely successful onslaught on the dam on the night of the 26/27th and blew a large hole in

it; air photographs shortly revealed many stranded barges where the canal had run dry, and the damage took four months to repair.

Another saboteur, whose identity is hidden behind the pseudonym of *Arrosoir*, tackled a fortnight later some locks on the important Briare canal. On 12/13 August he blew them up; they also were closed to traffic for four months, and over 3,000 lighters trying to evade the Gigny obstacle had their journeys blocked for that time. The same agent then went across to the Marne-Rhine canal and blew up a pair of locks at Mauvages, west of Toul; this left two sections of the canal bone dry for six weeks, and he took the incidental opportunity to burn 36 barges loaded with goods on their way to Germany.

The most useful of these attacks, so useful that they drew a letter of thanks and congratulation from the British Admiralty, were made in early November. Pella tackled another *barrage* on the Seine-Rhône canal, at Port Bernalin, fifty miles nearer the Mediterranean than Gigny, on 8/9 November, he destroyed ten sluices and cracked the central pillar of the dam. On the night before this success, the main ARMADA team of Basset and Jarrot had returned to France after a brief rest in England from the exertions of SLING. They undertook at once the re-destruction of Pella's Gigny target, which had just been repaired. What followed is best told from Basset's report:

On the 10th I decide to attack the barrage, for the guard that night consists only of fourteen French gendarmes. I get two bombs ready in 25-litre oil drums. At three o'clock I make a reconnaissance, and at nine p.m. we set off: two vehicles, eight men. Hour of attack: two a.m. At ten we stop, at four km from the barrage. I post *Goujon* and an electrician, to cut off the electric current and the telephone at five minutes to two. Then, with four men, I cross the Saône at Thorey bridge, and we begin the approach march. The moon is full, it's as bright as day, we have three km to cover to the barrage. We creep along the hedges and through the bushes on the river bank. At midnight we still have over 500 yards to go, under the eyes of the gendarmes.

Off I go, on my stomach, with one comrade, while my other companions follow slowly, pushing the charges in front of them. Fifty yards short of the barrage, a bush blocks the only way forward, and the gendarmes have reinforced the block by covering it with dead branches, which I have to shift to make a passage for my chaps, I suppose I'm making the devil of a noise, and I keep thinking I see gendarmes looking straight at me. I'm only 25 yards from them, and any moment I expect to be in a hailstorm of bullets.

Quarter to two – all my men are there except for the ones carrying the charges, who are fifty yards behind. I get the whole party together, and we wait for two o'clock.

Ten to two – the gendarmes go back into their hut, after a last flash round with their searchlight. In fact two big searchlights have been sweeping the barrage every five minutes since the attack that failed a fortnight ago.

At that moment it's quite absurd – there we are, the five of us on the slope twenty yards from the police post; we feel as if we're on the parapet of a trench.

Two o'clock. Out goes the light: forward! I get into the hut, point my tommy-gun at the gendarmes. All but one are frightened, him I have to threaten to shoot. I cut off their revolver holsters and make a pile of their rifles, which we shall take away for the maquis.

I order two of my men to bring up the charges while we bind the gendarmes with parachute cord, we lay them in the grass a hundred yards away, and I go down onto the barrage to lay my two charges. The drums are not watertight, and in spite of our precautions only one will go off; it will make a breach in the foundations fifty feet wide.

Return by the same route at 2.35. Explosion and return journey without incident.

Comic detail: next morning the gendarmes explain that the coup had been made by parachutists, for they had heard aircraft all night; and they produce the parachute cord as conclusive evidence.⁴⁷

No more traffic passed through the barrage till February.

Compared with these brilliancies, F section's special sabotage parties in 1943 do not look distinguished. Six officers were dropped – SCULLION I – on 18 April to attack a synthetic petrol plant near Autun, found it too heavily guarded, and came away; they were no good at hiding, and VIC had a lot of trouble extricating them, losing several agents compromised by their indiscretions. Hugh Dormer the party's earnest commander begged to be allowed to try again. A project to send him to the St Quentin canal (HOUSEKEEPER) was scrapped when Connerade the one-man advance party reported against it. Finally on 16 August in SCULLION II Dormer took another party of six, this time with one subaltern from the previous party to guide it in, to attack their original target; they managed to plant their bombs, but did hardly any damage, and only Dormer and a sergeant escaped.⁴⁸ The others were sent to Flossenbürg. And on 18 August G. L. Larcher who had been on SCULLION I took DRESSMAKER, a party of four, to attack the tanneries at Mazamet in the Tarn. They found that their targets were already disused, fell ill, and came home.

SCULLION troubles apart, the year was a quiet one for DF except for opening up VAR.⁴⁹ Two new lines were established between Paris and Belgium: GREYHOUND/WOODCHUCK, run by George Lovinfosse a Belgian business man from a country house near Châteauroux, and PIERRE/JACQUES the creation of the Dutch Zembsch-Schreve and the Anglo-French J. M. G. Planel, rudely described by an STS instructor as 'a public danger with any kind of firearm' but a good morse operator.

On the more regular, working circuit front, F's first problem of the year was posed by the Girard-Frager quarrel that disrupted CARTE.⁵⁰ Both men demanded a hearing in London; Girard arrived late in February, and Frager

– accompanied by Peter Churchill, who organized both pick-ups – in mid-March. The CARTE organization, it was clear by now, had no practical value: it was too large, too idealistic, too madly insecure.⁵¹ Girard did not make a good impression in London even at the beginning of his stay; and he was almost unhinged by the news that shortly reached him, that his wife and two of his daughters had fallen into German hands. After a false start in May, he was eventually able to leave for the USA in August; his standards of security are shown by a series of talks he gave to interested New England matrons about the precise methods of running clandestine land and air operations.⁵²

London decided that the only sensible thing to do with what was left of CARTE was to split it up into smaller circuits which would accept orders from Baker Street and try to do some actual sabotage. Frager undertook to run the largest of these circuits, DONKEYMAN, and to centre its activities round Auxerre, midway between Paris and Dijon; but its territory was still far too wide, for he was authorised also to operate in Normandy and in Nancy, and Dubois the wireless operator he took back with him by Lysander in April preferred to work near his own home at Tours. (Dubois – *Hercule* – was so highly thought of by F that he was allowed to choose his own place of work; he was a freelance operator, not tied to Frager's circuit.) An even worse defect in DONKEYMAN than wide range was a long-drawn-out entanglement with the Abwehr. For while Frager was in England (24 March–14 April) the Abwehr, unconsciously echoing the thoughts of Baker Street, decided it was time to close CARTE down, and moved in on the five-month-old addresses they had found in Marsac's stolen briefcase.⁵³

Marsac himself was the first man they arrested – within forty-eight hours of Frager's departure for London; and this earnest, impecunious scholar was no sort of match for the dexterous Sergeant Bleicher. Bleicher passed himself off as a colonel in the German intelligence services whose sympathies lay with the allies and against the nazis; could Marsac arrange for him to go over to London to discuss with the allied high command suitable arrangements for getting the nazis out of the way? Marsac was indiscreet enough to give Bleicher a note or two to some members of his circuit near Annecy; and with this help the German approached Roger Bardet and Odette Sansom, the latter of whom suspected him from the start. They told Jacques Latour, who looked after their air arrangements, to find a Lysander ground; this he did, though warning them strongly against using it. Through Rabinovitch, London was promptly informed of Bleicher's plan; and promptly turned it down, ordering all contact with Bleicher to be cut at once.

When Peter Churchill returned to the field by parachute on 14/15 April⁵⁴ he had of course received the same order to keep clear of *Colonel Henri*. Humphreys and Buckmaster both instructed him to avoid Odette Sansom as well, till she had broken with Bleicher. As it turned out she was on his reception committee; greeted him affectionately; and persuaded him to spend a few nights at the hotel she was using at St Jorioz.⁵⁵ After dark next

evening Bleicher and some Italian troops called there; arrested Mrs Sansom in the hall; and a quarter of an hour later, going upstairs, found Churchill – always a heavy sleeper – fast asleep in bed and arrested him as well.

A number of unfortunate consequences followed this arrest; there would have been more if Bleicher had done his job efficiently. A few messages received that day were successfully concealed by Mrs Sansom. Churchill was long worried by the belief that he had jotted down in a pocket-book the telephone numbers of three principal Riviera helpers; but either the Germans never found it, or the numbers were safely encoded. Rabinovitch, reconnoitring the scene of the trouble some weeks later, was able to spirit away a suitcase – hidden by the innkeeper on Churchill's orders, and missed by Bleicher – which contained a pistol, parachuting gear, nearly half a million francs, and (unknown to Churchill) the texts of over thirty messages exchanged with London during his absence.⁵⁶ De Malval, when arrested some months later in Paris, was confronted with what purported to be a copy of a message from London to SPINDLE he had seen before, which read: 'On reaching the coast of France, the agents who have come by felucca will proceed straight to the Baron de Malval, Villa Isabelle, Route de Fréjus'.⁵⁷

SPINDLE thus went out of action as a working circuit; but Rabinovitch remained at liberty. He and Hazan (*Gervais*) supervised the winding up of the circuit's remaining contacts, round Annecy and on the Riviera, before making their way safely back to England through Spain. One of the London-trained agents in touch with CARTE, Ted Coppin who had been working in Marseilles, was arrested there with *Giselle* his courier on 23 April, for reasons that remain obscure; he disappeared altogether for a time, and was eventually thought to have died while in German hands in September. No more arrests followed on theirs, a tribute to their stoicism.

Girard's withdrawal and Peter Churchill's arrest left the lower Rhône valley and the south-eastern coastline open; three different circuits, JOCKEY, MONK, and DIRECTOR took them up. The man who eventually became JOCKEY's organizer, Francis Cammaerts (*Roger*), had reached France in March by the Lysander that took Churchill and Frager back to England. He was a son of Emile Cammaerts the Belgian poet, and like many intellectuals of his generation – he was born in 1916 – had been a pacifist in the thirties while he was up at Cambridge, where he played hockey and got a second in history. His brother's death in the RAF altered his views on war; and in August 1942 he gave up farming to work in SOE. He was physically conspicuous, for he was well over six feet tall, with feet huge in proportion; luckily for him, he was also fairly nordic in appearance. Beaulieu reported he was 'rather lacking in dash' and 'not suitable as a leader'.⁵⁸ But he had extraordinary gifts as a clandestine operator, which enabled him to overcome his bodily handicap for secret work by flair and daring. Above all, he had those intuitions of danger which seem to preserve natural clandestines from traps the less wary fall into.⁵⁹

As soon as he set foot on French soil, with orders to act as Frager's lieutenant and liaison officer with London, he sensed that all was not well with the DONKEYMAN circuit he was to join. The reception committee, seven strong, drove him straight to Paris in one crowded car; long after curfew, but *ça ne risque rien* – the motto of careless agents – as one of them had a doctor's permit to drive at any hour. Their conversation suggested even to such a newcomer that their security was at best sketchy; 'but I felt', he wrote when it was all over, 'that they knew all about the job and thought that my fears were groundless. If I had known then as much as I know now about clandestine work, my hair would certainly have gone grey during that drive'.⁶⁰ He stayed up late talking to Marsac, to whom he confided two million francs and his pistol, and lunched with him next day; and then 'spent part of the afternoon wandering around Paris, buying a few books and looking in shop windows, trying to get the feel of the life, until I was asked for my identity card and had to submit to a superficial body search outside a Metro Station. This unsettled me a bit and I preferred to go back to my lodgings and spent the rest of the evening doing nothing. This was my first taste of boredom and lesson in patience'.⁶¹ Next day Marsac did not turn up to lunch; and Cammaerts heard that afternoon of his arrest. Duboudin, who had come out to France on that same Lysander, also disappeared almost immediately, and presumably was swept up by the Germans as part of the same hunt; unlike Marsac, he never returned. Cammaerts left at six for Annecy, where 'a number of suspicious looking boys and girls with bicycles posted at various places on the square in front of the station', who turned out to be DONKEYMAN sub-sub-agents, thoroughly alarmed him: 'I must have stood there looking for the first time really like an English traveller in a foreign country'.⁶² He shortly met Odette Sansom and Rabinovitch. They looked after him well, and gave him a breathing-space he could use to get accustomed to life in occupied France; they also introduced him to Roger Bardet, whom Frager had left in charge of DONKEYMAN. Cammaerts' invisible antennae twitched again; he distrusted Bardet even more than he trusted Rabinovitch, and again he moved, this time to a safe address in Cannes Rabinovitch provided. He lay low there for a month in safety, while he built up his cover as a schoolmaster recovering from jaundice.⁶³

This was the last occasion, during two tours of duty extending over nearly fifteen months in all, when Cammaerts spent more than three or four nights in the same house. He had been so thoroughly alarmed by his opening experiences that he cut himself off completely, for the moment, from CARTE and all its descendants, and settled down to create a new circuit that should, before anything else, be properly secure. So 'he never went to a strange address without checking up, or being personally recommended by a reliable member of his organization';⁶⁴ and to ensure that as many as possible of the members of his organization were reliable, he watched the leaders with great care himself for some weeks before he approached them, and persuaded

them to agree with him that no one else should even be approached till they had been watched for a while in their turn. In the end he built up a circuit security squad of seven or eight men, two of them invaluable French retired policemen, who spent their time in shadowing prospective recruits – and indeed people who had already entered the circuit; Cammaerts himself included.⁶⁵

At this stage in the war there was no severe pressure of time, so JOCKEY could accumulate its forces gradually; and thanks to its organizer's continual insistence on security, it accumulated large and competent ones. The care Cammaerts took over recruiting provided the basic reason for his success; and he followed it through with constant reminders about the rules of safety. 'He insisted that the men should automatically work out for themselves a perfectly good reason for all their actions, in case of snap controls or surprise arrests. He did not allow any material to be transported uncamouflaged. ... He advised his men not to spend more money than they had done previously, and to keep as un-noticed as possible.' Moreover, 'His groups were never more than fifteen men, and should this number be exceeded he advised the group chiefs to divide into sub-groups.'⁶⁶ Group leaders all knew him; but on his urgent advice kept his identity, even his nationality, a secret. And while he knew how to reach them, none of them knew how to reach him or where he lived. The system in fact worked almost too well: 'on one or two occasions when [he] arrived by car in a farmhouse where his W/T operator was working, he could find no trace of him at all. He later discovered him hiding as he had not recognised the car.'⁶⁷

His first operator, introduced to him by Rabinovitch, was Auguste Floiras (*Albert*), a resister from the start, who had distributed clandestine newspapers from the prefecture at Marseilles before taking the July felucca to Gibraltar in 1942. Trained in England as a wireless operator, he had returned to France on the *Lysander* that collected Cowburn, with instructions to work for CARTE; he survived the arrest of his own family at the end of the year, and sided with the activists in the disruption. But neither Frager nor Peter Churchill had provided him with much to do; the Annecy neighbourhood seemed unhealthy to him; and he went into hiding at Montélimar. There Cammaerts found and approved him in May, and they joined forces; on 27 May Floiras sent the first of the messages for JOCKEY that he transmitted to London during fifteen months' flawless activity. These messages totalled 416, a remarkable achievement that made a section record.

F at once agreed to Cammaerts' proposal that JOCKEY should be entirely separated from DONKEYMAN, and trusted his judgment to make his own contacts and arrangements. Two assistants were sent to him from London in mid-June. One was a courier, Mrs Lefort, whose arrival by *Lysander* and departure to Ravensbrück are noticed elsewhere;⁶⁸ she was arrested in mid-September at Montélimar, staying in a house her organizer had warned her not to visit. The other, half her age, was P. J. L. Raynaud (*Alain*), a young

French subaltern who was used by Cammaerts as a sabotage instructor. He was dropped on 17/18 June to a reception by Culioli and Mme Rudellat, and spent the next two days with them and two Canadians;⁶⁹ his hosts impressed him as having a first-class organization, and he passed on without a hitch through Paris to Montélimar where he met Cammaerts on the 22nd, the day after Culioli's arrest.⁷⁰ There he had a narrow squeak when some Italians made a routine check on the house he was staying in; he moved eastward into the country, and settled down to organize and instruct sabotage groups in the southern part of the Drôme.

The JOCKEY circuit had been set up extempore by an organizer who had not gone to the field expecting to do anything of the kind; but in the course of the second half of 1943, travelling to and fro by motorcycle, he established small independent groups of reliable and intelligent men all up and down the left bank of the Rhône valley between Vienne and Arles, and inland between the Isère valley and the Riviera hinterland. Cammaerts in fact did much better than the older and staidier Skepper (*Bernard*) who had been intended by F section to run MONK, another part of the CARTE organization that seemed worth salvaging. Skepper arrived by Lysander with Mrs Lefort, on 16 June, and travelled south with her. He went on to Marseilles, where Arthur Steele (*Laurent*), who was parachuted three nights after his own arrival, joined him as his wireless operator. They made one particularly useful local contact, with Pierre Massenet, who after the liberation became the first gaullist prefect of the Bouches-du-Rhône. Plenty of MONK'S adventures can be found in Elizabeth Nicholas' *Death be not proud*, for Skepper and Steele were joined in the autumn by Eliane Plewman (*Gaby*), their conspicuously attractive courier. She was parachuted into the Jura on 13/14 August, and took some time to make contact with her circuit. As all three of them were later arrested and none of them returned little can be said of what they managed to do; in 1943 it consisted of getting themselves ensconced, ready to start sabotage later.⁷¹

One other fragment was saved from the wreck of CARTE: a group round Arles under Jean Meunier (*Mesnard*), who had occasionally acted as Girard's deputy when the latter was away, and sided with the activists when CARTE broke asunder. SOE called Meunier's circuit DIRECTOR, and communicated with it, by courier through Switzerland – Meunier had a sub-circuit at Annemasse, practically an eastern suburb of Geneva, which could easily pass messages to and fro. None of the members of DIRECTOR were London-trained – a unique feature among F's circuits; but Baker Street thought well enough of their possibilities to send them numerous supply drops, and in the course of the year the circuit received nearly two million francs. It was probably a DIRECTOR sub-circuit near Annecy that looked after Squadron-leader Griffiths who crashed on 14/15 August on a supply operation to PIMENTO from Tempsford, spirited him away wounded into the hills under the noses of the Italians, and saw him over the Swiss frontier within a week.

Griffiths wrote a vivid account of his adventures in the maquis which Selborne circulated round the War Cabinet, on whom it must have made an impression; for the pilot found himself in the hands of a body of alert, well-armed, well-disciplined, uniformed young men, who evidently had the run of the side roads at least in their neighbourhood and were passionately pro-British. Unfortunately DIRECTOR was snuffed out early in 1944, and its achievements if any are unrecorded. As it had no British-trained member, it has been left out of the time chart in appendix H.

Although, again, almost all the main agents concerned fell into German hands and disappeared, it is possible to give a more connected account of PROSPER, which replaced CARTE as F's leading circuit. By the new year Suttill had got his headquarters thoroughly organized and had work enough in hand to keep busy both his wireless operators and his courier Andrée Borrel, of whom he wrote in March 'Everyone who has come into contact with her in her work agrees with myself that she is the best of us all.'⁷² In the first five months of the year they received as many as 240 containers full of arms and explosives from England. A substantial proportion of the arms was passed on by Suttill to acquaintances in the French communist organizations in the 'red belt' round Paris; but at their insistence Suttill kept all the liaison arrangements with them strictly to himself, and no surviving evidence indicates exactly where the arms went or how many of them there were. 'Germans are killed daily in the streets of Paris', said a report by one of Suttill's friends in the spring, and '90 per cent of these attacks are made with arms provided by us, e.g. to the Communists';⁷³ but no details survive. Of Suttill's non-communist friends a good deal more is known. Guerne ran a group for instance among the Paris intelligentsia, which included a nascent medical section staffed by Professor Alfred Balachowsky (*Serge*) and Geneviève Rouault the painter's daughter, among others. Some of them were organized in semi-independent circuits in the country; SATIRIST for example, the organization of a 29-year-old sculptor, Octave Simon. Simon had been in resistance of one sort or another since 1940, and had done some work in 1942 for Philippe de Vomécourt and Aron; after de Vomécourt's arrest he managed to get into touch with Suttill, who asked him to organize a circuit in the Sarthe. He had many friends among the country gentlemen of south Normandy; the country was reasonably free of German troops and full of suitable caches for arms; and a good many of the weapons dropped to Suttill were put in through Simon.

Another sub-circuit of Suttill's was JUGGLER whose leader had also been in resistance early on; this was Jean Worms (*Robin*), who had been making himself useful to various intelligence réseaux in Paris as early as September 1940. In 1942 he had met Virginia Hall, Basin and Peter Churchill; and had left France for England by the October felucca. Suttill and Andrée Borrel received him when he parachuted back into France not far from Chartres on 22 January 1943; they were accompanied by Jacques Weil, an old friend

of Worms, who became the second-in-command of JUGGLER.⁷⁴ Worms' task was to organize sabotage groups on the upper Marne round Chalons, and they had a few early successes with derailments and are said to have had ten ten-strong sabotage groups in and around the town; but both Worms and Weil were Parisian businessmen and they spent a good deal of their time in the west end of Paris.

BUTLER, another of Suttill's sub-circuits, overlapped territorially with SATIRIST in the Sarthe, but did not overlap socially with the PROSPER groups at all. BUTLER's organizer was François Garel (*Max*) who had been one of F section's earliest contacts in southern France and had escaped with Bégué from Mauzac. He was dropped blind on 23 March with Marcel Rousset (*Leopold*) and Marcel Fox (*Ernest*); but the drop was a bad one and they lost all their baggage including Rousset's wireless set. Rousset went to Paris, got into touch with Suttill through Lise de Baissac, and had fresh sets and crystals dropped to him. By the middle of May BUTLER was a fairly effective working organization, concentrating on railway targets between Sablé-sur-Sarthe and Angers. South of BUTLER another old hand, E. M. Wilkinson, was at work round Angers with PRIVET, a small group of his personal friends. Further up the Loire, between Tours and Orleans, PROSPER had several much more amateur groups of local resisters;⁷⁵ and on 25 April Suttill himself, Norman, and the local group round Meung-sur-Loire attacked the power station at Chaingy near Orleans. They cut off the supply of power from it altogether, and the coup was hailed both locally and in London as a great success; but the cut had been made by the over-simple expedient of cutting the surrounding pylons, and full output was restored by cable eleven hours later.

Other groups of Suttill's that attracted containers from London were centred round Falaise under the leadership of J. M. Cauchi (*Paul*) who was later often though wrongly accused of betraying the circuit to the enemy, and on the other side of the Seine round Gisors, under a Frenchman of English descent, George Darling. During the mid-June moon period PROSPER received 190 further containers; it was now getting dangerously widespread, and its disruption was imminent. The whole disastrous business of the downfall of PROSPER is so complicated that it has had to be treated in a separate chapter, which follows this one.

Parallel with PROSPER was Antelme's much smaller circuit BRICKLAYER. Antelme's main purpose was to discuss those various points about supply and finance at the time of an eventual invasion that seem to have concerned F section in 1942 and 1943 almost as much as they concerned the SHAEF supply staff when it came to the point in 1944. Through a friend who knew a governor of the Bank of France, he made provisional arrangements to provide currency, in any necessary quantity, for an invading allied force; other acquaintances offered him over a million tins – tins, not tons – of food. Besides his financial and commercial inquiries, which were interesting and

provided some possibly useful contacts of which in the end no use was ever made, Antelme had various political missions of which the most important was to Herriot. He saw Herriot in March and found him benevolent towards the allies but reluctant to play any active part, and moreover in a particularly bad state of health.⁷⁶ In mid-March Antelme returned to London by Lysander; he parachuted back early in May, with a further mission to bring Herriot out by air which he could not carry through because the old man had been placed under much stricter surveillance and was for the time being inaccessible, Antelme continued to move round in business circles in Paris; and collected a good deal of economic intelligence, which though useful to the allied war effort was of course not really the business of SOE. He made one useful personal contact, with a thirty-five-year-old lawyer, Maître W. J. Savy (*Wizard*) whom he brought back with him when he escaped by the skin of his teeth from the disasters that overtook his friends in PROSPER during the summer.

Three other overlapping circuits were at work in the second half of 1943 to the west of the PROSPER area, which for much of that time had to be left lying fallow. These circuits, PARSON, CLERGYMAN and SACRISTAN, were all in eastern Brittany and the Vendée. SACRISTAN was run by E. F. Floege (*Alfred*), born in Chicago in 1898 but so long resident in Angers, where before the war he ran a bus company, that his French was perfect and his English had a French intonation. As he 'lived in Angers before the war he had contacts in the district and was easily able to form the nucleus of his organization. He contacted friends of whose loyalty he was absolutely certain and appointed them as leaders in various centres. They in turn recruited a small number of men to form a group'.⁷⁷ He was parachuted not far from Tours on 13/14 June with Trotobas' assistant *Olivier* and received by Dubois, who acted for a short time for Floege as well as for many other people as a wireless operator. On 19 August Floege received an operator of his own, André Bouchardon (*Narcisse*), a young civil servant. Floege had his headquarters tucked away in the country at Mée, a village about twenty miles north-west of Angers; he did all his business with his groups of saboteurs through two couriers, one of whom was his own son and both of whom he thought reliable; the circuit received seven drops of arms during the autumn and was just ready to start serious work when, immediately before Christmas, it collapsed. Young Floege was caught in a routine *raffe* in Angers, and broke down under interrogation: most of the sub-agents whose addresses he knew were shortly afterwards arrested. Bouchardon was caught in a little restaurant at Mée on 23 December by a large party of Germans, with whom he struggled violently: he was shot in the chest after being felled to the ground. The Germans bundled his body in the back of a car without bothering to search it; during the journey into Angers the supposed corpse drew his revolver, shot the three men in the car, and escaped from the wreck. Floege and he managed to hide in Paris until the VIC line took them over at the end

of February 1944; they both came out over the Pyrenees, Bouchardon still with a bullet lodged in his thorax.⁷⁸

CLERGYMAN also deserves brief record. Robert Benoist, whose narrow escape from CHESTNUT'S fall is described elsewhere,⁷⁹ went back to France by Hudson on 20/21 October on a short mission. He was to establish CLERGYMAN round Nantes; avoiding all contact with PRIVET, Wilkinson's exploded circuit just upstream, and using his own friends instead. His immediate task was to blow up the pylons just east of Nantes that carried into Brittany electricity generated in the Pyrenees; secondly, he was to prepare cuts on all the railways round the town, to be made on D-day; thirdly, he was to do what he could to secure the port of Nantes against sabotage by the Germans when they came to retreat. Dubois, as brave and as rash as himself, was to be his wireless operator.

But a fortnight after Benoist reached France the German direction-finders at last caught up with Dubois; put onto his neighbourhood, it is said, by a courier of his stupid enough to take a transmitter on a bicycle carrier to a football match, and to boast of it loudly while watching the game. German police broke into his room while he was transmitting. One he killed, another he wounded, but he was immediately taken prisoner with nine bullets in him. (The incident is depicted in *School for Danger*, with Rousset in the wireless operator's part.) Dubois was wise to have a pistol beside him; he would have been wiser to have a protection team. He recovered enough to be sent to Germany; unlike his wife, he did not survive his concentration camp. Benoist was thus deprived of the channel through which he could readily have ordered stores; in any case he found the country-side round Nantes too crowded with refugees to be much use for clandestine drops. He was *débrouillard* enough to revisit his father's estate south-west of Paris and collect some of CHESTNUT'S arms from there; but he could find no explosive for his pylon attack, nor any contacts useful for his counter-scorching task; so he left the newborn CLERGYMAN in its cradle and asked Déricourt to send him back to England at the next opportunity.

PARSON, the other Breton circuit, worked to the north-west of SACRISTAN, round Rennes. Its organizer, François Vallée (*Oscar*), who had already won an MC working with SOE in Tunisia, was dropped on 17 June, and joined five weeks later by the Belgian Gaillot (*Ignace*), affectionately known in Baker Street as 'grandpere', Gaillot was an interior decorator by profession; 'extraordinarily careful in every little detail of security ... a very attractive person with an original independent and orderly mind',⁸⁰ a shrewd kindly face, and plenty of self-confidence; he was nearly fifty years old. Georges Clement (*Edonard*) the wireless operator who came with him was much younger; he was born in Petrograd a week before Lenin seized power, and had been an undergraduate at Brasenose College Oxford before the army claimed him. By the middle of August Vallée had organised several clandestine sabotage groups of a dozen men each in the triangle St Brieuc–Rennes–Nantes; they

were not yet conducting any sabotage lest they attract reprisals. He reported also that he had guerilla groups at his disposal which could harass enemy movement on orders from London. The circuit received four drops of arms; and made several useful local friends, one of whom, André Hue, later took on HILLBILLY, a circuit of his own. But another local recruit, René Bichelot, a dental student at Rennes on the run from the relève, got involved with the rescue of a party of American airmen shot down in a raid on Nantes in September. The peasants with whom the Americans sheltered took them to the nearest active resister they knew, who happened to be Bichelot; this sort of embarrassment often overtook SOE's circuits when they were trying to lie low. In this particular case the Americans were safely placed on an escape line and got away; but the German police began to take an unhealthy interest in PARSON'S activities. Clement was caught while transmitting on 28 November, and thereafter the circuit had to go to ground.

Clement, confusingly, was the field name of the organizer of the next circuit that needs to be considered, SALESMAN. Most of inland Normandy was looked after, more or less efficiently, by PROSPER'S sub-circuits round Falaise and east of Rouen. SALESMAN worked downstream from Rouen to Le Havre, independently of PROSPER, and with a good deal more success. The organizer was another old hand from 1941, an escaper from Mauzac, Philippe Liewer, a thirty-two-year-old French journalist, who was a pre-war friend of Langelaan's. He went into France by one of Déricourt's Lysanders in mid-April, taking with him a French-Canadian assistant called Chartrand (*Dieudonné*). They spent a few weeks establishing themselves in Rouen; an accidental meeting with Garel, the BUTLER leader, led to Chartrand's transfer from SALESMAN to BUTLER. Isidore Newman (*Pepe*) on his second mission, arrived by Lysander in July as a wireless operator to Liewer, who also received late in August an assistant, Robert Maloubier, to act as his sabotage instructor.

Liewer found most enthusiasm for working with the English right in the prohibited coastal zone in the port of Le Havre. He could easily have formed groups thousands of men strong; but had the common sense and the sense of security to keep his effective forces down to a few score who were thoroughly trained, well armed, reliable and competent. During the summer and autumn, he received enough arms drops to provide personal weapons for all his men – he claimed a total strength of 350 almost all of whom 'have been tried and tested on either a real or fake operation'.⁸¹ Only Liewer himself and Claude Malraux (*Cicero*), the novelist's half-brother, who acted as his second-in-command, knew how to get into touch with Newman; and he could reasonably claim that 'Generally speaking, the security of the circuit is excellent'.⁸² They did manage to do quite a lot of useful sabotage, including an attack on the electricity sub-station at Dieppedalle just outside Rouen, which was brought to a standstill for six months by fifteen pounds of well-placed plastic on 31 October 1943. A month later, Liewer was able to report, 'the official case file was put away marked "no result of enquiry", and [he

thinks] the circuit's security was so good that the officials were completely beaten', although the prefecture offered rewards and amnesties to anybody who would give them information about the local saboteurs.⁸³ His circuit's principal achievement may be worth reporting in his own words; it was the destruction of a small warship:

... The minesweeper was of some 850–900 tons, equipped with three pom-poms, two four-barrelled machine guns and a bigger gun for action at sea. It had been attacked, probably by Typhoons, earlier in the year and had been brought up to the yards of the Ateliers et Chantiers de Normandie, near Rouen, for repairs. It had undergone a complete overhaul and was finally ready for trials early in September, 1943.

At about 11 a.m. on the morning of the trials, the [German] Admiralty representatives came aboard and with them the Manager of the Shipyard, the Chief Engineer and other notables. The ship then left for her trials down the Seine as far as Caudebec, returned upstream and docked at about 3 p.m.

The trials had been satisfactory, champagne flowed, the Manager and Engineers were warmly congratulated, the quality of French workmanship received glowing tributes and a cheque for Frs. 5,000,000 was handed over for the work so successfully accomplished.

The Admiralty representatives then departed in a haze of enthusiasm and at 5 p.m. the crew of 45 men arrived to get on board the supplies which were already at the quay-side. They loaded Frs. 12,000,000 worth of Asdic equipment, 20 tons of ammunition and supplies for a three months' cruise. At about 9 p.m. they returned to the barracks to fetch their kit.

Sailing time was to be 4 a.m. next morning and the steam pressure was maintained at 5 kgs.

Meanwhile SALESMAN'S representative had not been idle. At about 5 p.m. he managed to get aboard with two others on the pretext of a last minute adjustment and planted a 3 lb. plastic charge as low as he could on the inside of the hull. SALESMAN had made up this charge himself and it was fitted with two six-hour time pencils; he had handed it over three days before with instructions to place it in position at the most propitious moment.

In due course, at 11 p.m. the charge exploded, making a very satisfactory hole, later ascertained to be 5 feet by 3 feet, and the ship sank in six minutes. It could be seen next morning with just the tip of the funnel showing above water.

The Gestapo arrived at 7 o'clock in the morning and very quickly decided that the charge had been placed internally. They found out that thirteen men had access to the ship and asked that each of these men be pointed out to them on arrival.

Their method of questioning was ingenious. As each man arrived, they took him kindly but firmly by the arm and said, 'My poor friend, you forgot to press the pencils'. Achieving nothing by this method,

however, they assembled the thirteen and told them they would all be shot unless the man responsible confessed.

In the meantime, the German Admiralty had acted. Hating the Gestapo quite as much as the Army does, they brought in their own experts, two of whom entered the water at 2 p.m. and pronounced that, by the size and characteristics of the hole, the charge could only have been an external one!

Baffled, the Gestapo was forced to release the thirteen workmen who departed, honour vindicated, to their homes. On the other hand, the hole in the ship was on the side next the quay, and there had been a sentry on duty on the quay. The sentry was arrested.

Furthermore, the crew, arriving at what should have been the ship's side at 2 o'clock in the morning and finding no ship, had given vent in no uncertain manner to their pleasure and gratification at the prospect of remaining on shore. The crew also was arrested. After a brief court-martial, the delinquent sentry and the member of the crew whose joy had been the most unbounded, were shot, and the remainder, forced to don the despised field green of the Wehrmacht, were sent to the Russian front.

Justice having been so satisfactorily assured, the Gestapo and the Admiralty – and also the workmen – returned to their respective businesses.⁸⁴

The trouble of course, about SALESMAN was that with a constant run of electricity, railway and factory sabotage, it was bound to attract German attention, and however careful Liewer and all his subordinates were about security, bad luck was practically bound sooner or later to get them into trouble. Even Liewer's contacts in the Rouen police who provided reliable warnings of impending round-ups could not be wholly relied on for safety, and late in 1943 Liewer himself was ordered to withdraw. He came out of France after some weeks' delay by Déricourt's last Hudson, bringing with him a good deal of useful intelligence about German preparations between the Seine and the Somme for launching V1 flying bombs.

As has been remarked already, it was not any part of SOE's purpose to provide intelligence; and yet a great deal of operationally useful information such as Liewer's was bound to come SOE's way, and was of course passed on. Except for tactical purposes after D-day,⁸⁵ little use was made of SOE's parties in France for intelligence purposes: their character did not fit them for such work. As Marshall, the organizer of ADE, once put it.

Our field operatives were for the most part temperamentally unable to regard Intelligence as anything but the essential prelude to action. To whet their appetites for action, by directing them to locate enemy activities or resources, and at the same time to forbid action, is akin to giving a lion a raw sirloin to play with but not to eat.⁸⁶

East of SALESMAN, three circuits did important work in this year in north-eastern France, and each deserves a short review. Two of them, FARMER and MUSICIAN, whose organizers had jumped together in November 1942, were at work among the battlefields of the BEF of the previous war. Their zone of activity reached from Armentières, on the Belgian border near Ypres, southward to Soissons and Senlis. It lay astride main railway lines that would be important to German supply whenever an invasion of north-west Europe took place, and quite vital if ROUNDUP were ever mounted – the main seaborne assault on the beaches between Boulogne and the mouth of the Somme that the British contemplated in 1943 and the Germans expected in 1944; and railways were to be FARMER'S and MUSICIAN'S principal targets.

Michael Trotobas (*Sylvestre*), FARMER'S Brighton-born leader, settled in Lille and dived straight into the atmosphere of Graham Greene's *Brighton Rock*.⁸⁷ Biéler, visiting him in the spring, found him having a bath in the scullery of the working-man's house he was living in, arguing vociferously through the steam with some members of a gang of bookies' touts; others of his close acquaintance seemed even less savoury. But Trotobas knew what he was up to. For a man in his late twenties, he was unusually worldly-wise; he deliberately chose to work in circles that understood already the importance of keeping their mouths shut, weighed up the people he met, and soon assembled a strong and secure body of saboteurs, devoted to himself and supported by the least pro-German members of the local French police. Many of his best helpers were Poles, who were not in touch with MONICA or found it too cautious.

At the end of February 1943, FARMER had its first successful derailment; forty railway trucks were destroyed and the Lens-Béthune line was closed for two days while the track was cleared. By midsummer FARMER'S railway gangs were scoring fifteen or twenty derailments a week, and imposing appreciable delays on goods traffic. But explosives could only reach them by roundabout routes from farther south; and their communications were maddeningly weak. The wireless operator, Staggs, turned out unable to make effective contact with base, and was only otherwise useful on occasional odd jobs. In December 1943 Staggs was arrested by the Germans, who never established his connexion with SOE and released him within two months; he stayed quietly in the neighborhood till the allies overran it, secretly training his neighbours in the techniques of sabotage he knew. Trotobas had to communicate with F through one of PROSPER'S operators in Paris, who seemed to him insecure, or from April through Dubois, away on the Loire; and to get most of his parachuted stores by goods train through his SNCF sub-agents who were in touch with MUSICIAN or PROSPER. Dubois received an assistant for him on 13 June, *Olivier*, a tough young Anglo-French steel-worker, who got to Lille ten days later and introduced himself to Trotobas. (It will soon be clear why his real name is not given.) The meeting was cool; for *Olivier* was a sabotage instructor, not the wireless operator Trotobas hoped for, and

the organizer was busy in the closing stages of mounting a remarkable coup. He had to waste the 25th on a fruitless journey to Paris, where he narrowly escaped from the PROSPER imbroglio.⁸⁸ On the night of the 27/28th he took a party of some twenty men, *Olivier* among them, to deal with the locomotive works at Fives in the eastern suburbs of Lille, one of the largest and most important in France.

They went up to the gate quite openly, wearing gendarmerie uniforms supplied from a friendly police station at Wattrelos, ten miles away on the other side of Roubaix; Trotobas himself carried the simpler disguise of a decent suit and a Gestapo pass. He explained to the night watchmen that they had come to inspect the factory's security arrangements; and under pretext of searching in every corner his men loaded up the transformer house with explosives, placed – on Rheam's principles – on the most sensitive spots. Just as they were withdrawing through the main gate, one of the charges went up prematurely. Trotobas urged on the watchmen the importance of doing nothing whatever till he came back in a few moments with teams of firemen and investigators; and vanished into the night. Four million litres of oil were destroyed and twenty-two transformers damaged, some of them irreparably; and the works were reported out of action for two months. This was far too optimistic an estimate; a postwar investigation showed that production was never completely stopped, and that after four days it was almost back to normal.⁸⁹ Nevertheless the coup provided an example of the kind of demolition that SOE could effect more precisely and more cheaply than could air bombing attacks; the factory was in a heavily built-up area, and to bomb it would probably have cost many scores of French lives.⁹⁰

Trotobas worked the Hazebrouck–Roubaix–Arras triangle hard that summer and autumn, so hard that he fell ill; he had a steady run of successful rail and factory sabotage to report, including the stopping of another big factory at Lille in October. 'On the Amiens–Arras line', according to an informed spectator a month later, 'there were four derailments in five days which caused considerable perturbation in the railroad timetables. Both sides of the track are absolutely littered with damaged trucks, carriages, and material.'⁹¹ *Olivier* meanwhile did not hit it off with Trotobas, being jealous of the rest of the circuit's admiration for 'Capitaine Michel', as they all called him, and too flamboyant – not to say unintelligent – to understand the need for Trotobas' security precautions. These went quite far. The organizer enrolled himself in the GMR, under a complaisant inspector who required no duties of him, and did most of his work in Vichy uniform. *Olivier* he kept at arm's length, at the southern end of his area where a couple of useful drops of explosives were received in July, and used him mainly on conveying the parties of escaping airmen that seemed to come FARMER'S way.

For the price FARMER had to pay for its vigour was that it became well known to everybody in its neighbourhood who was anti-German; this in

turn multiplied the number of points the Germans might be able to seize on to penetrate it. In the end they broke into it through its Arras escape contacts. The best of these was Berthe Fraser, who had arranged Yeo-Thomas's escape in the hearse. Dewispelaere, a local baker, introduced her to Trotobas and *Olivier*, for both of whom she did a lot of work; *Olivier* was often in and out of her house, and met there both escape line couriers and RF's pick-up organizers in northern France. It was to her that *Olivier* naturally turned when he wanted to get out of danger a sub-agent who had shot a German soldier nosing round a stolen Wehrmacht lorry in the circuit's Arras garage. The sub-agent got as far as the Pyrenees foothills before he was arrested; tortured a little, he admitted his identity; tortured a lot, he gave Dewispelaere's name.

Olivier and Trotobas last met in Arras on 23 November, when the former understood the latter to say he was about to move house (*Olivier* was one of the three members of the circuit who normally knew where the organizer lived). Two nights later Trotobas confided to Biéler, who had come to see him overnight at Lille, that *Olivier* was 'too much of a matador' and not really up to his job. In the small hours of the 28th, this judgment was tragically borne out. The Germans raided Dewispelaere's house at 1 a.m. and arrested both the baker and *Olivier* who happened to be staying the night there; though by day the agent bristled with threats and revolvers, he was captured without a struggle. His captors were brusque with him, stamping on his bare toes; soon discovered who he was, drove him over to Lille where they arrived at a quarter to four, and beat him up some more, demanding his organizer's address. *Olivier* fairly promptly pointed out the house he believed Trotobas to have left; and from the street – today renamed Rue du Capitaine Michel – heard shots exchanged as they raided it at a quarter to seven. The raiding party came out one man short, and angry; saying their inspector had been killed, and they had only shot in return a ginger-haired girl and a man in GMR uniform. *Olivier* was shown the bodies, and realised he had killed his organizer.

Fearful remorse at least kept him from saying more. There were about a score of arrests of suspected FARMER contacts that day and the next, and several of the arrested men were shot out of hand. But the damage spread no farther; loyalty to Trotobas was so strong that his death inspired his followers to work harder to revenge him, not to despair. Through Biéler and Déricourt they reported to London that 'the threads of the organization ... remain unbroken and ready for the resumption of activity';⁹² and Pierre Seailles, one of the local chieftains, kept the circuit in being. In December, only a few days after Trotobas had been shot, his men destroyed eleven locomotives at Tourcoing and put the repair shop there out of action. FARMER in fact ended the year full of fight.

So did MUSICIAN. Biéler was able to settle down in his working area round St Quentin by March, and fully justified the hopes the training schools placed

in him, if he was not hurried; 'very conscientious, keen and intelligent ... generations of stability behind him ... sound judge of character; good natured; even tempered; absolutely reliable; outstandingly thorough and painstaking; born organizer'.⁹³ On his way eastward from Paris, he scored a derailment of a troop train near Senlis in February; and in the second half of 1943 his teams were cutting the main line from St Quentin to Lille about once a fortnight. During the year he received sixteen drops of sabotage stores, and distributed them round a couple of dozen groups of sub-agents carefully chosen to deal with railway, telephone and petrol storage targets in the quadrilateral Douai-Maubeuge-Laon-Soissons. Communications were not easy for him, either locally (because of his damaged spine) or with London; he used PROSPER'S wireless channels till they disappeared in June,⁹⁴ and then TINKER'S. At last, in September, he was sent his own wireless operator, Yolande Beekman, a Swiss woman of thirty-two, as steady as reliable and as unforgettable as himself: in the words of one of their helpers 'They were both of the finest stuff imaginable'.⁹⁵ With two agents of such integrity at its centre, MUSICIAN was likely to do creditably; and they made up in steadiness anything they lacked in fire. While the impetuous Trotobas scurried from demolition to demolition, the more methodical Biéler concentrated on preparing his longer-term targets; though he gave his teams some training by blowing up an occasional bridge or petrol pump. He kept his railwaymen friends supplied with one of SOE's special stores, abrasive grease which wore out the parts it was supposed to lubricate; during the autumn he had the satisfaction of reporting ten locomotives put clean out of action by this device, which has the clandestine advantage of being practically untraceable.

To the south of MUSICIAN, Ben Cowburn on his third mission – this time as *Germain* – assembled a small circuit round Troyes which also specialised in railway sabotage, and like all Cowburn's own projects was meticulously secure; it was called TINKER. What made discretion all the more important in this case was that he was involved willy-nilly in contacts with PROSPER; for Culioli received him when he and his wireless operator parachuted down south of Blois on 11 April, and his best local contact in Troyes, the timber merchant Pierre Mulsant, was a close friend of Octave Simon of SATIRIST. Cowburn decided to take a great many risks himself, and to keep everyone else as innocent as he could; the more he could concentrate the danger of discovery on his own person, the more he could be sure that he knew what risks were being run; besides, 'If I alone were spotted I could hope to hide, but my recruits were tied to their houses, businesses, farms and families, and were very vulnerable'.⁹⁶

This had results verging on the ridiculous. Through the discreet Dr Mahée, a leader of the local OCM, he secured a house on the outskirts of Troyes which he used as a depot and a one-man factory, where he broke down bulk supplies from London and made them up into charges, working by himself. 'The almond smell of plastic explosive permeated the empty house', he

wrote afterwards, 'and I often thought that, working at the table in my shirtsleeves, with piles of hand-grenades and incendiary pots, and rows of sten-guns and pistols along the walls, I must have looked the almost perfect picture of an anarchist preparing to blow up the Grand Duke of Moldavo-Slavonia in a pre-1914. theatre play. I only needed a pair of false whiskers.'⁹⁷ But these theatrical trappings were backed by some serious work.

It is worth quoting his own almost contemporary account of what he called a 'modest operation', the destruction of six large engines in the Troyes locomotive roundhouse and the serious damaging of six more on the night of 3/4 July.

Senée [a local recruit] and I set out from my arms depot at 11 p.m. On our way we met a German patrol and were preparing to shoot it out, but they did not challenge us. We reached the rendezvous which was under a bridge on the canal at midnight and the other four men turned up. At 1.15 we got inside the depot through the way which had been discovered. I then took each group of two men under the engines and showed them where to apply the stuff. There was a good deal of fumbling – the difficulty of struggling about underneath the mechanism of a big engine in absolute pitch darkness has to be experienced to be believed. However, I finally assigned a certain group of engines to each one of the three teams and we got to work. After 40 minutes we left, each team going home separately. We had to cross the tracks to get away and, by a stroke of luck, the floodlights which were located at one of the level crossings must have been out of order as they were off. At La Chapelle-St-Luc Senée and I very nearly walked slap into a Feld-gendarme. This meant a hurried retreat across the fields.

We had been going about half an hour when the first charge exploded. We had set two-hour time pencils and this one prematured. We hurried on our way home and the bangs began to succeed each other at the rate of one every ten minutes or quarter of an hour. There were thirteen explosions. As soon as the first one occurred, all police and German garrisons were called out and invaded the depot. They rushed about, snatching open doors and poking machine guns into them. They did not realise that more than one locomotive had been attacked. When the second explosion occurred they hurriedly ran out of the depot and surrounded it from a distance. Then, as the other explosions succeeded, they began to realise it was a wholesale job and they kept quite clear of the round houses.

I understand that in the early hours of the morning Oberst von Litrorf, the German military commander at Troyes, came himself and rebuked his men for their nervousness and chattering teeth. He climbed on to one of the engines which was on the transfer line, as nobody realised that these engines had been doctored also. No sooner had he got on to the footplate than the engine next to him blew up. The colonel sprang off and scurried across the line to his waiting car. Entrance to the depot was forbidden and hours later, when there

were no more explosions, the Germans proceeded to arrest and question people.

They started, I believe, with people who were in the round houses at the time, but soon released them when they found they could not have done it. They arrested and released several people got their experts down and came to the conclusion finally that it was a specialist's job – probably the work of the Intelligence Service. They found one of the charges which had failed to explode, had photographs taken of all the damage and said it must have been a British agent who had directed the job. After a few days they seemed more or less to have given it up as a bad job. The German experts gave the opinion that it could not have been some local Gaullists who had done it, in fact one of the Gestapo officers said he took his hat off to whoever was the perpetrator.

The day after the operation, the Germans put wooden barriers around the Field-Kommandantur and had their troops on the march preceded and followed by motor-cyclists and machine-guns. They also reinforced the guards.

The population were quite delighted with all this business, as nobody had been put in jail for it. The people at the Chapelle-St-Luc had been ordered to evacuate the place as they were afraid the British would bombard the engine depot. They then said the British had obviously decided to do it otherwise, in order not to cause injuries among the population, and everybody was happy. I saw Thierry afterwards and he confirmed the permanent nature of the damage done to the locomotives.⁹⁸

The cream of the joke was that

... my friends were much entertained during the following weeks listening to people who could, tell just how it had been done, some even claiming to have partaken in it. According to one of the stories which was going about, a squad of British sappers had been dropped from an aeroplane near the railway yards, and picked up later by the same machine which had landed in a field. Pierre [Mulsant] would come and say, 'I have just been talking to yet another chap who did it; this one got in through the roof ...'.⁹⁹

As a useful sideline, TINKER was also able to make one small, helpful contribution to the battle of the Atlantic: a consignment of shirts on their way to U-boat crews was treated with an itching powder, invented by some sadistic staff officer in London and inserted by Cowburn's sub-agents at a local shirt factory. People came to believe in Troyes that at least one U-boat had surrendered in mid-ocean, to secure treatment for what its captain believed to be a totally incapacitating form of dermatitis; a tale it would be agreeable to credit. The truth is that where France was concerned SOE's impact on the indispensable campaign against German submarines was slight, for a decisive tactical reason. This was simply that the five great German submarine bases

on the Biscay coast were too carefully guarded to be penetrable by the sort of parties SOE could put into the field. Frequent directives from London encouraged agents to assault U-boat equipment wherever they could find it; but the only equipment likely to be open to SOE's assault travelled by rail, and by the chances of war SOE's best teams of cheminots were in the PIMENTO and JOCKEY circuits in the Rhône valley and among FARMER's ill-supplied parties round Lille, none of them working on lines that handled U-boat traffic much. OVERCLOUD's promising contacts with LA BÊTE NOIRE, the east Breton railwaymen's organization, were snuffed out with OVERCLOUD. The anti-submarine campaign was of desperate importance to Great Britain: defeat here would be final, and of course SOE took it seriously. Oddly enough, by dint of having ordered the sabotage of U-boat parts and accessories so often, staff officers came to believe that a good deal of it was being carried out, and reports to this effect were made from time to time to higher authority, which accepted them.¹⁰⁰ They had little if any backing in fact.

Cowburn – to resume the narrative – had a gift rare in successful offensive organizations: he knew when to stop. By mid-September Gestapo pressure round Troyes was getting too hot, prudently he withdrew by air, taking with him as far as Paris a survivor from a special duty Halifax recently shot down on other business while in TINKER's area. He handed TINKER over to Pierre Mulsant. The Germans remained hot on TINKER's trail, and Mulsant came out in turn by the November Hudson. He brought with him both Mme Fontaine the courier, and John Barrett (*Honoré*) the wireless operator who had dropped with Cowburn in April and steadily supported him all through this mission. Another friend of Cowburn's, Charles Rechenmann who had been busy elsewhere, came with them. TINKER was thus for the time being in suspense; it was replaced by DIPLOMAT, at first a dormant circuit. DIPLOMAT's organiser was a young Parisian, Yvan Dupont (*Abelard*), a discovery of George Starr's. Starr had used him for several months in WHEELWRIGHT (of which more shortly) round Agen in the heart of Gascony, and had then sent him out to England through Spain. The F and training staffs thought well of him, and he was dropped into the Aube in October to take over as many of Mulsant's TINKER friends as seemed still to be safe. He was authorized to maintain the existing teams of railway saboteurs round Troyes, an important junction where five branch lines ran into the main line from Paris to Belfort. He stayed quietly there during the winter, establishing his cover, sounding out the reliability of his helpers, and preparing to make DIPLOMAT active when London sent him word.

The urban circuits we have just reviewed covered between them most of the industrial and transport targets of importance outside Paris which lay in the triangle Lille–Troyes–Le Havre. Their working members had plenty of fighting enthusiasm; the territory of each was comparatively small; and except in Lille, where Trotobas' reckless energy built up a large combatant

force, their numbers were small also. Frager's DONKEYMAN, a more countrified circuit, should have adjoined TINKER to the south, in the Yonne. After a month's earnest discussions in London about the future of CARTE, Frager returned to France by one of Déricourt's Lysanders in mid-April; his new directive was referred to above.¹⁰¹ But he could not easily disentangle himself from the widespread connexions he inherited from CARTE, or from his acquaintances in PROSPER; the fall of that circuit hit him hard, as the next chapter will show, by removing INVENTOR the sub-circuit F sent in to help him in May. And worse even than rubbing shoulders with the PROSPER team was knowing and trusting Roger Bardet. Bardet, when SPINDLE collapsed in mid-April, rejoined Frager without losing touch with the Abwehr; indeed the Germans were in closer touch with him than ever, for they arrested him again. Even his own account of what followed does himself little credit. He said that Bleicher released him from Fresnes early in May, on condition that he kept the Abwehr supplied with the messages exchanged by DONKEYMAN with London and with the location of its arms dumps. Frager, according to Bardet, urged him to accept this bargain, and thereupon concocted with him a bogus story of how he had escaped from a prison van while being transferred from Fresnes to another prison in Paris.¹⁰² This part of the tale, unsupported except by Bleicher and by Bardet's fellow double agent J. L. Kieffer,¹⁰³ is quite out of character for Frager, who was impetuous and mercurial, but honest as the day; it was a necessary myth – necessary to Bardet, that is – and Frager did not live to denounce it. Undoubtedly Bardet kept to his part of the bargain; he was constantly in and out of Bleicher's flat,¹⁰⁴ carrying scraps and snippets of information about SOE, and he secured Frager's entire confidence, so that his snippets were often informative to the Germans. He introduced Frager to Kieffer an old French air force pal of his own, who offered to take over the running of Frager's groups in central Normandy; as Kieffer was introduced to Frager by the trusted Bardet, he was given charge of all DONKEYMAN'S Norman business. Frager never knew that it had been this same squat, balding intriguer who had first put the Germans on the trail of INTERALLIÉ; nor that Kieffer and the Abwehr handled jointly several drops of arms from London, which were quietly stored away out of real resisters' reach.¹⁰⁵

The rest of DONKEYMAN'S misadventures this year must wait for the following chapter; they were closely tied up with PROSPER and various wireless games. But we must refer to one more DONKEYMAN connexion now; from it, it was once plausibly though wrongly thought, an important wireless game derived. Frager was believed in London to have a body of men working under him in south-west France – some put them in the Dordogne, others farther still from Paris, round Toulouse; but only their leader's name, Meric, was known for certain. Dr Meric maintained he had been trying to fight since September 1940, but had never had the luck to connect up with a working circuit. CARTE had proved a broken reed; he had settled down to propaganda work in the lower Tarn valley, till a summons from Frager

brought his hopes nearer to reality. One solitary arms drop near Montauban in July 1943 was all that ever came of this; when it came to D-day, 'we fought as we could'. He was not in any sort of connexion with PRUNUS.¹⁰⁶ Doubts about his security were expressed, even during the war, and after it he was put on trial for 'faux maquis' – that is, for pretending to be organizing resistance when he was not; with what result I have not discovered.¹⁰⁷ But certainly Frager was still in touch from time to time in the late spring with Rabinovitch, and Rabinovitch equally certainly did visit Toulouse, to mend the broken wireless set of the PRUNUS operator Bloom. Shortly thereafter, both Bloom and his organizer Pertschuk were arrested; and it was for a time suspected that they had been arrested because Roger Bardet had somehow wormed out of Rabinovitch a means of getting in touch with them, and arranged for another double agent to go down to Toulouse and put them in German hands. Dates make this tale improbable; Bardet was not re-arrested till the second half of April, while Pertschuk and Bloom were both in German hands by the 15th.

It is always possible that Bardet's dealings with the Abwehr go back to one of his earlier arrests, at Aix-en-Provence in January 1943 or even on the Riviera in early November 1942, when nominally the Abwehr's writ did not run south of the demarcation line; on both occasions he had escaped, or had been released, with suspicious promptitude. Yet there is no need to seek out a double agent or a group of double agents who betrayed the PRUNUS leaders: in effect they betrayed themselves. The reader will recall how Bloom and Pertschuk got in touch with each other, in straightforward defiance of every security rule.¹⁰⁸ A neighbouring organizer with keener nerves than theirs had to go and see them, early in the year, at a contact address they provided; the address turned out to be a black market restaurant, where the whole high command of PRUNUS – six or seven people – were gathered round a single table, finishing an excellent dinner and chattering away in English.¹⁰⁹ This was riding for a fall; and they fell.

In January Bloom's wireless was got into action; the circuit received four drops of stores, and Pertschuk began to elaborate a plan for blowing up his most obvious target, the Toulouse powder factory. As these plans were nearing completion, he received on 11/12 April a parachuted French-Canadian assistant, Duchalard, whose main task was to work a *Eureka*, useful in southern Gascony, where many valleys look alike from the air and dropping aircraft were near the limit of their range. Pertschuk settled Duchalard in a safe house, did some other business in the country, and returned that evening to his lodgings in Toulouse. The Germans were waiting for him in his room, and arrested him quietly; they had got the address out of an arrested sub-agent. Within a week they had all the principal members of his circuit in their hands, except for the newly arrived Duchalard who returned fairly unobtrusively to England through Spain. On Bloom, or among his belongings, the Germans happened on a snapshot of Pertschuk in British uniform, which Bloom in a

characteristic moment of Cockney impishness had taken the trouble to smuggle past the watchful field security staff who should have searched him completely before ever he left England. This scrap of paper had disastrous consequences. Not only did it 'blow' Pertschuk sky-high, rendering ineffective any attempt he might have made to tell any sort of cover story; it provided the Gestapo with a weapon it could use with devastating effect against other captured agents, especially agents who had known him, or met him in prison. They all knew how careful the security searches were; that little photograph suggested irresistibly to them that the Germans had an agent in Baker Street, which was just what the Germans wanted.¹¹⁰

These arrests had been made by the SD, not the Abwehr; they followed the usual German pattern, of careful study and penetration leading to the removal of all the leading figures in a circuit at one swoop – much the same had happened to AUTOGIRO a year earlier, much the same was supposed to be happening to SPINDLE simultaneously. This time the SD added a refinement. As they could not catch Rabinovitch, Goetz, their section IV's Paris wireless expert, was sent down to Toulouse in a hurry to play Bloom's captured set and codes back to the British. He got no assistance whatever from Bloom, whose behaviour as a prisoner was impeccable – far more distinguished than it had been as a free man; or from Pertschuk, who treated his captors with the dignity and spirit of a free man far beyond his years – he was not yet twenty-two. And Goetz got no assistance from London either. It was at once realised that something had gone wrong with Bloom's transmissions; exactly what was wrong was long disputed, and what London called the *Bishop* case filled several bulky files, but Goetz's initial, inexperienced attempts to take the British in had no success, and after a month traffic closed down.

The disappearance of PRUNUS left PIMENTO, Brooks's railway circuit, without a wireless channel; Brooks was rather relieved than otherwise. Just after Pertschuk's arrest, a train on which Brooks reached Lyons from Toulouse was met in force by the Gestapo; fortunately for the agent, Bizot (*Lucien*), who was on the station, had the presence of mind to handcuff him and drive him rapidly away in a French police car. Brooks by this time had been nine months in France; he had plenty of railway sabotage teams organized, and a few of them already armed. To improve his followers' morale he let them blow up a couple of locomotives in the Montauban roundhouse, a long day's walk north of Toulouse, in June; and cut the same month the railway running north-east from Toulouse to Gaillac and the Aveyron. But his main effort this year was in the Rhône valley and among its tributaries, as far north as Mâcon and well up into the Alps. André Moch (son of Jules Moch, the celebrated socialist minister) set up a sound working group on the line to Turin through Grenoble and Modane, and frequently cut it – on London's orders – in July and October. Roger Morandat, the brother of the Morandat who led RF's important OUTCLASS mission for de Gaulle, at first took charge of the Lyons groups, organized several reception committees, and received

one drop in January; in March he was arrested, but another of Brooks's agents, Jean Dorval a French police inspector, went straightway to Morandat's flat and cleared all the compromising papers out of it before the Gestapo had got round to looking for them. In future Brooks kept as little as he could on paper – he made it a rule never ever to carry compromising documents himself; and such archives as his section had were in the hands of a sub-agent doing time in Geneva jail, where the organizer thought it unlikely that they would fall into German hands.

PIMENTO in fact was as near a model for caution as a sabotage circuit could be, and yet succeed in carrying on useful work. In the course of 1943 it received over thirty drops of weapons and sabotage stores – far too many weapons indeed to suit its organizer's convenience. He could use explosives, delay action devices, fuses, abrasive grease in almost unlimited quantities, but had so few outlets for weapons that in the end he had every member of his many reception committees armed with a Bren gun. This was a pointless piece of lavishness. Most of the Brens were never fired; they would have been far more use among the country circuits that clamoured for them when guerilla finally broke out, and got Stens instead. Brooks was inundated with Stens also, and found many of them far too dangerous to use till the burrs of metal left in their muzzles by over-hasty manufacturers had been filed off.

He got so many more arms than he needed because Baker Street found early that it could trust him, because the RAF liked working to his punctual and efficient receptions, and because he was one of the very few organizers who made proper use of his Eureka's and had a depot ground manned every moon. Also, by and large, when he was ordered to do something within his range he did it, promptly. His circuit's role in effecting not merely dislocation, but eventually total stoppage, on some important railway lines is worth attention. Moreover Brooks in spite of his youth could exercise authority from a distance. On London's orders, he spent the last three-and-a-half months of 1943 in Great Britain – he was brought out by Hudson in mid-August, and divided his time in England between refresher courses and a honeymoon.

While he was away, André Moch had charge of his circuit; Moch had been thoroughly grounded in Beaulieu's principles by Brooks, and now had to apply them. For the chiefs of staff were encouraged enough by SOE's sabotage achievement, so far as it was detectable in London, to require a special effort to be made in the autumn to block rail traffic between southern France and Italy. MONK did a little useful work of this kind; JOCKEY did more; PIMENTO did more still. No exact indications survive in SOE's papers of the derangement caused by these line blockings to the German reinforcement plan; it may only have been slight, but the subject would be worth further study.

Why were the chiefs of staff ready by now to make use of SOE's fighting resources for specific tactical ends, if those ends happened to lie within agents' means? One good reason for using and trusting SOE in this way had

just been provided by another F circuit in France; though as a matter of fact the good work done was not within SOE's proper charter.

It was done by SCIENTIST, de Baissac's circuit round Bordeaux. This complex body fell into two halves; a small group of port saboteurs, and a much larger and more miscellaneous group of country *résistants*, some in the rural Landes between Bordeaux and Dax, others near Angoulême and even in Poitou and the Vendée. Several of the leading figures, including de Baissac himself who was a friend of Suttill's, quite often visited Paris also, where they had a further group of supporters; de Baissac sensibly enough tried to pass these people over to PROSPER. But they were handed back to him by Bodington in August, after PROSPER's collapse; their presence shortly precipitated the ruin of SCIENTIST. Meanwhile the smaller and tougher part of SCIENTIST had produced a valuable gain, in the shape of intelligence about the arrivals, the departures, and the cargoes of blockade runners using the Gironde. Their news was more precise, fuller, and sooner available in London than from any other source, and brought a letter of congratulation from the Admiralty in September which said that this 'ground intelligence from Bordeaux ... has virtually put an end to blockade-running between Europe and the Far East this year. The stoppage of this traffic is of the highest importance as the supplies ordered are vital to the Japanese.'¹¹¹

By bad luck for SCIENTIST, Hasler's marine commando operation FRANKTON had given the Germans a disagreeable jolt in December 1942, and thenceforward they patrolled the dock areas on the Gironde with such ferocity that de Baissac's well-informed teams never got another chance to attack. The submarine pens, there and at La Pallice, were even more stiffly guarded. All the saboteurs could do to affect them was to doctor a single batch of submarine accumulators on their way to the latter port with tablets intended to make them decay; the results were never observed for certain, though two U-boats are claimed as sunk at sea by the French.¹¹²

The less specialised and more countrified part of the circuit grew fast; much too fast. When the organizer was in London on a month's visit in March and April, he reported that he could already count on the services of three or four thousand fighting men, most of them in Gascony; though so far he had received hardly any arms for them. By the autumn this total had quadrupled: 11,000 men were said to be available in the county of the Gironde alone, apart from several hundreds out in the Landes and five thousand or so in Poitou and the southern Vendée. Only nine arms drops had been made by May; but by the end of August SCIENTIST and its sub-circuits had received as many as 121 aircraft loads of arms and stores, in nearly two thousand containers and packages. De Baissac could thus dispose of almost nine tons of explosive, and could provide about half his force with a personal firearm. 'Evidently something powerful was building up', as Bourne-Patterson put it in retrospect,¹¹³ the same point was clear to the Germans.



Gubbins



Buckmaster



Bodington

Some Baker Street personalities



General de Gaulle



Jean Moulin
Rex or Max



Pierre de Vomécourt



Christopher Burney



Ben Cowburn



Virginia Hall

Early agents (all survived)



Charles Grover-Williams
Sebastien



Robert Benoist
Lionel



Michael Trotobas *Michel*



Gustave Biéler *Guy*

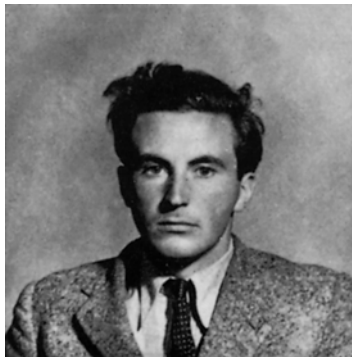

Brian Rafferty *Dominic*

1942 vintage: all killed



Gilbert Norman *Archambaud*



Jack Agazarian *Marcel*



Francis Suttill *Prosper*



France Antelme *Renaud*



Noor Inayat Khan *Madeleine*

Some figures in the *Prosper* circle (all executed)



Lt. Col. George Starr *Hilaire*

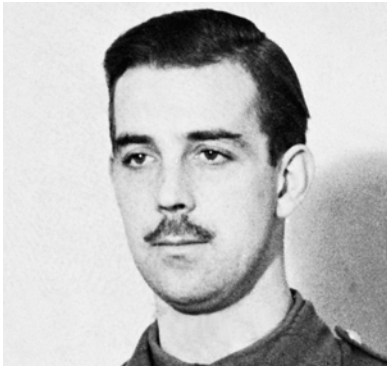

Lt. Col. Francis Cammaerts *Roger*



Lt. Col. R. H. Heslop *Xavier*

The three F Section colonels



Henri Déricourt (*Gilbert*)
At his trial



Claude de Baissac *David*



Harry Rée *César*



Harry Peulevé *Jean*



Yvonne Baseden

Four who came back



A corner of the Ratier workshop at Figeac, after treatment

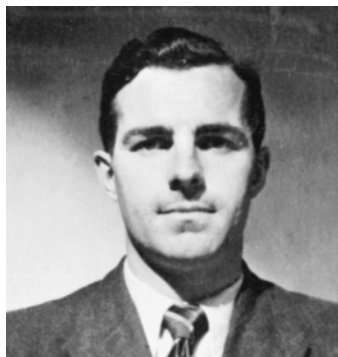

Paul Rivière
Roland

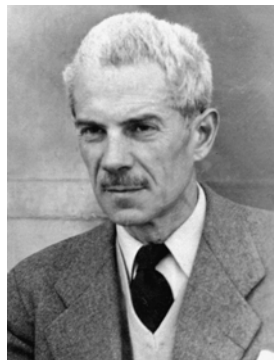

Michel Brault
Miklos, Jérôme



F. F. E. Yeo-Thomas
Shelley



André Jarrot *Goujon*



Raymond Basset *Marie*

Some figures in RF section (all survived)



Pierre Fourcaud *Sphère*



Yvon Morandat
Yvon



Jean Pierre Rosenthal
Cantinier



Paul Schmidt *Crab, Kim*

More RF agents (all survived)



Daylight drop in Corrèze, 14 July 1944



The Drop. Vercors, 14 July 1944



Removing stores from a reception



ACOLYTE tackles some points



‘Wizard prang’: a Pimento derailment near Ambérieu

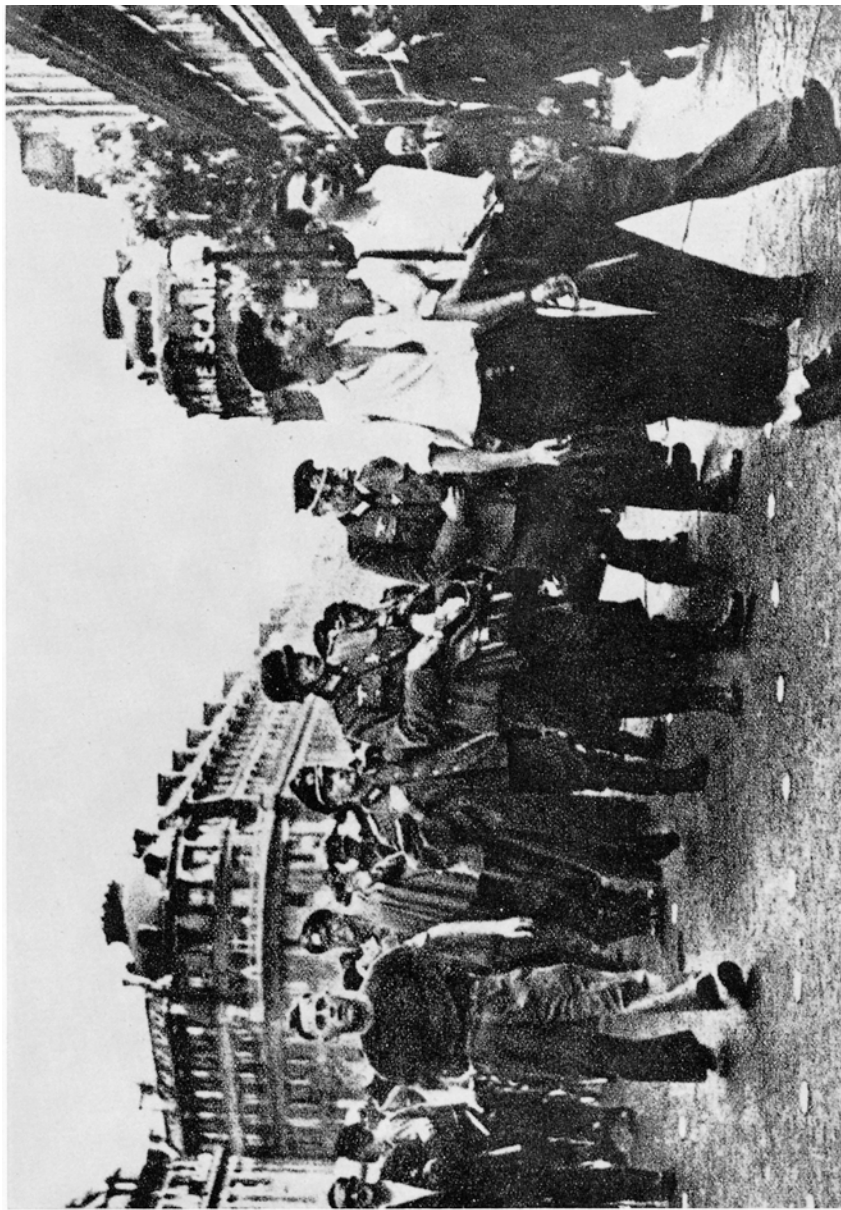

Place de l'Opéra, 25 August 1944

SCIENTIST in fact was snowballing, too soon for safety. Had the allied invasion of France come in the early autumn of 1943, as many millions of people hoped it would, SCIENTIST might have played an important role on the Biscay coast, distracting enemy attention from the main landing for a short but perhaps a vital period of time. Twice that autumn the BBC broadcast warning messages to every active SOE circuit in France, indicating that the invasion would come within a fortnight; but the action messages that should have followed, on the night of the landing, were not sent. The warnings formed a small part of the deception plan that covered the Italian surrender and the Salerno assault (8 and 9 September). No doubt word that these warnings had gone out was passed round, too far for the safety of resistance circuits, so that the Germans heard of it; for this the indiscretions of local sub-agents were responsible. The staff concerned with deception relied on indiscretion, and might have thought more about safety.

SCIENTIST'S troubles came from a higher level. The circuit rested, rather uneasily, on both ends of the resistance political spectrum; on the FTP, strong on the Bordeaux dockside and in some up-country districts, and on the OCM, a body rather of giraudist than of gaullist leanings run by former French army officers of conservative bent. De Baissac's Paris detachment consisted of OCM people, under a French major with an Irish name – Marc O'Neil. De Baissac took his second wireless operator. Marcel Defence (*Dédé*), a young London-born Frenchman dropped to him in May, up to Paris in August to help O'Neil extricate this group from the fringes of the PROSPER disaster. He returned to England again himself, for a few weeks as he thought, by the mid-August Lysander that brought Bodington back from France; his sister travelled with him. He left the circuit in charge of André Grandclément.

Grandclément, a retired colonel in his late thirties, was the son of an admiral; Antelme had discovered him in Paris, and introduced him to de Baissac as a likely helper. He was a thoroughly gentlemanly figure, far to the right in politics – he had once been ADC to Colonel de la Rocque – and already a man of standing in the OCM, to which O'Neil had introduced him over a year before.¹¹⁴ It was he who produced the bulk of resisters whom de Baissac armed, and through him most of the reception committees were found. Naturally all these air operations – thrice as many even as PROSPER was getting – attracted a good deal of German attention; and in July, about the time they were hitting PROSPER hardest, the Germans made some scores of more or less experimental arrests round Bordeaux. Through one of these prisoners they got Grandclément's address, raided his house, and arrested his wife. He was away; but among his papers they found a card index of names and addresses in clear, in which a hundred of his agents were lightly encoded – his cover was that of an insurance agent – as 'potential policy-holders'. A hundred more arrests followed at once, decapitating the OCM in the region:¹¹⁵ for none of Grandclément's following knew the Beaulieu rules about moving house at once if anyone in the circuit was arrested.

The survivors soon learned; for worse trouble followed. Grandclément went off to consult O'Neil in Paris, where the Gestapo arrested him on 19 September, in a café, from a photograph found in his house. The Paris SD team were busy, as the next chapter will show; the new prisoner was sent back to Bordeaux, where an exceptionally dexterous piece of work by Dhose the local Gestapo chief turned him round. Dhose appealed to Grandclément's honour as an officer and a gentleman, and rapidly convinced him that France's real interests lay with Germany's; international communism was the monster that threatened to swallow up both alike, and all the heritage of European culture with them, unless they combined to beat it down. Would Grandclément mind helping to free the Reich from the slight menace in rear his resistance groups represented, so that the vital battle in the east could go forward more easily? All that was needed was for him to indicate where SCIENTIST'S arms were stored; that done, of course his friends would be released.

Grandclément fell in with this arrangement promptly, and led the Germans on a tour of secret arms dumps. After the liberation, which he did not survive,¹¹⁶ there was much dispute in France about whether he could possibly have done what he did sincerely. There is no doubt, from a long paper he once wrote, that he was perfectly sincere; he did honestly, at the time, think that he had not betrayed his country, that no one else had been arrested by his fault, that he had 'only done [his] duty as a Frenchman', not only before but after his arrest.¹¹⁷ His colleagues did not share his opinion.

A few days after his return to Bordeaux, the Germans – sure by now of his collaboration – let him out for a couple of days, unshadowed. He went to call on Charles Corbin, a fifty-year-old French police inspector who was one of de Baissac's most reliable helpers; to his surprise, he met Landes and Defence there as well. Landes reached at once for his pistol, and ever afterwards regretted he had not shot Grandclément on the spot; he did not care to do so in the presence of Mme. Corbin and her daughter Ginette (whom he later married¹¹⁸), and from this piece of quixotry the worst of SCIENTIST'S troubles derived. Grandclément told them all what he was going to do, and why; and was hurt and puzzled that they did not agree with him that it was right. He went off to do it; and the agents did their best to race him to the dumps. Most clandestine communications went by bicycle, Grandclément had a Gestapo car. So he enabled the Germans to capture about a third of the parachuted arms. The rest were either spirited away in time, or in caches he did not know.

One of the caches he betrayed was in the Duboué house at Lestiac, fifteen miles upstream from Bordeaux; the family there had been among de Baissac's best and earliest helpers, and Charles Hayes the sabotage instructor was staying with them when the Gestapo came raiding in the small hours of 14 October. Hayes and the son of the house held it for three hours, firing from the windows till the womenfolk hiding under the furniture were

wounded and both men were hurt too badly to keep the action up. They were all captured; rumour had it that in recognition of his gallantry Hayes was to be treated as a prisoner of war, but in the end he went to the execution ground at Gross Rosen.

Yet where Grandclément was concerned the Germans kept for once to their half of a bargain; they released not only the Grandcléments, but about half of their OCM prisoners. All of course were marked men, and organized resistance along the southern Biscay coast came almost to a standstill for a time. Defence just got back to Paris in time to warn O'Neil, who wound up his group and turned to other work; and after some trouble the wireless operator managed to get back to England by sea. Corbin meanwhile engaged in the delicate task of using his French police connexions to discover which areas Grandclément was going to visit next, so that Landes could fend off as much trouble as he could; a task that London rightly judged was bound to compromise him sooner or later. He and Landes both left France through Andorra at the end of November, and two months later were in London.

That was the end of the great SCIENTIST circuit that had reached from Paris to the Pyrenees; and yet, just as had happened with AUTOGIRO eighteen months before, people were leaving to join it as it was folding up. One of these people was caught soon after he landed;¹¹⁹ the other was not.

Claude de Baissac had got into touch with a sizeable group of FTP round Tulle, in the inland department of Corrèze, who acknowledged the novelist-politician André Malraux as their leader and were anxious to secure arms. When de Baissac reached London in August he proposed to add these new recruits to SCIENTIST; but the staff objected reasonably enough that his circuit was spread quite wide enough already. Would he pass the Corrèze contact addresses over to Harry Peulevé? He did so willingly. He trusted Peulevé, who had been his original choice as wireless operator; they had made an almost disastrous jump into Provence together in July of 1942.¹²⁰ Peulevé had escaped from the Spanish camp where he had been imprisoned, and had just finished an SOE refresher course; he went back to France by one of Déricourt's Lysanders¹²¹ on 17/18 September, to go through de Baissac's SCIENTIST friends round Bordeaux to set up AUTHOR in Corrèze. He was to be his own wireless operator, and for the time being to be the only British-trained agent in the circuit.

Peulevé's task was difficult enough when he left, viewing the habitual attitude of hostility most French communists displayed towards the British whom they despised and distrusted – even then – as capitalist warmongers. His difficulties were multiplied as soon as he arrived; for he was passing through Bordeaux in the earliest and most hectic moments of Grandclément's treachery. With uncommon soundness of nerve, he trod delicately among the tumbling fragments of SCIENTIST, got in nobody's way, least of all the Germans', and disappeared eastward as unobtrusively as he had arrived

from the middle Loire. When he got to his chosen area, he found a brisk guerilla in progress; from mid-September to mid-November the local resistance forces, both FTP and *armée secrète*, were engaged in almost continual running fights with the enemy,¹²² who were making an early and unsuccessful attempt to pacify a turbulent part of France as they had tried to pacify turbulent parts of the Balkans and western Russia. It is not surprising that Peulevé did not open up wireless traffic till the very end of October; but when he did come through, he reported himself already established and prepared to receive aircraft. During the ensuing winter, after the guerilla survivors had withdrawn into clandestinity, he armed and trained the separate forces in the Corrèze and the northern Dordogne of about 1,500 FTP with whom he worked through another Malraux half-brother, Roland, and a group nearly a thousand stronger of personal followers of his own.¹²³

AUTHOR remained compact and secure, in spite of these substantial numbers, because it was a country circuit and not a town one. There was a fundamental difference, so obvious that it may easily escape notice, between country and town clandestine work; for in the countryside everybody knows everybody else. (Proustians will remember how at Combray Tante Léonie's attention could centre for hours on a dog she did not know.¹²⁴) Yet in the great stone deserts of the working-class quarters of France's few large towns, all men might be strangers to their neighbours as they often are in London.

Some attempt at a widespread country circuit was made by Suttill the PROSPER leader in the occupied zone; but his circuit and its sub-circuits never managed to rid themselves of the Parisian flavour that turned out their undoing. He recruited country gentry and intellectuals all right; but few of them would stay in the country, for they had town houses and metropolitan interests that drew them frequently to Paris. George Starr's WHEELWRIGHT and Maurice Southgate's STATIONER were different. They were as catholic in their choice of assistants; Southgate's varied from exceedingly tough near-gangsters to the aristocratic Maingard, and Starr equally could keep in touch with several social strata at once. Theirs were essentially country circuits, wide-ranging from Orleans to the Pyrenees, and taking as their main task the organization, arming, and training of the nascent maquis.

But what were the maquis? They originated as bodies of young men who took to the hills instead of reporting as they should have done for the STO, the compulsory labour service in Germany that Laval instituted on Sauckel's insistence in the late summer of 1942. A few groups of young men camping out existed by early autumn; the onset of winter made them take themselves and their living conditions more seriously. The toughest of them stayed out in the forests and the mountains where they had taken refuge, and either built themselves log cabins, or took over deserted houses and made them more or less weatherproof. Lack of water was their worst trouble; close behind it came lack of food and drink and lack of warm clothing. Lack of security was quite far down the list, certainly below women and tobacco; for

the Germans did not yet appreciate that these little groups were anything more than unimportant gangs of outlaws, nor realise that they could represent any menace to their own hold on France.

SOE saw this; so did the most intelligent French leaders, Moulin, d'Astier, Brossolette, de Gaulle himself. Essentially, it was in the maquis that the national uprising was to find its bases. For these groups of outliers were ideally placed to collect and hide stores of parachuted arms, and could be trained to use them in reasonable conditions of security; much more securely in fact than people could be trained in villages, where elaborate cover was needed to deceive the Germans and none could deceive the gossips, and with chances quite unobtainable in towns to use live ammunition and explosives for training. Contact with maquis groups to secure their arming and training became, from this time on, a regular task of F and RF organizers alike.

It was taken seriously by Maurice Southgate (*Hector* of STATIONER); but he had a lot else on his mind as well. He was a survivor of the *Lancastria* disaster in June 1940,¹²⁵ and had entered SOE from the RAF two years later, at the age of 29. Though of British parentage, he had been born and brought up in Paris; as a schoolboy he had been a bosom friend of John Starr's; he designed furniture by profession.¹²⁶ His original tasks in France were two, both deriving from earlier work of Cowburn's: to develop a circuit round Châteauroux based on Octave Chantraine's acquaintances, most of them FTP; and to look into such possibilities as Charles Rechenmann could offer near Tarbes and Pau, far to the south in the foothills of the Pyrenees. He was dropped late in January 1943 with a courier, Jacqueline Nearne – the sensitive dark-haired heroine of the SOE film – and proceeded to give her a bad initial fright by stopping a peasant who was astir early and inquiring in English about when the next bus passed. This floater frightened himself as well, and helped him to take particular care about security in his far-flung circuit.

Rechenmann's helpers in the south were sound; they numbered nearly a hundred, and had all passed the same stiff initial test: escape from a prisoner-of-war camp in Germany. This meant that they all had some military training and some elementary knowledge of security; and Rechenmann used them for receiving and storing arms. Some serious immediate sabotage was attempted in Tarbes arsenal at midsummer, but only a day's delay was caused; the main electrical switchboard, which was destroyed, was easily replaceable. Rechenmann himself went to England for further training in November, and this end of the circuit went dormant for a while. The Châteauroux end was rather more active, under Chantraine and his friends; and Southgate also kept in touch with HEADMASTER, Rafferty's attempt at keeping a circuit going in the Bourbonnais. Rafferty's wireless operator G. D. Jones in fact received Southgate and his courier when they first arrived; one of Miss Nearne's main tasks was to maintain touch between HEADMASTER and STATIONER, and this involved her in a weary round of train journeys in the

elongated area bounded by Paris, Clermont-Ferrand, Toulouse, Pau, and Poitiers. HEADMASTER was broken up in early summer, probably owing to an indiscretion of Rafferty's – he was overheard saying as he left a Clermont-Ferrand cafe 'Yes, it's a fine moonlight night, we shall have great fun', and was followed and caught on his way to a drop.¹²⁷ Less than a week before, one of his teams had burned 300 tons of tyres in the nearby Michelin factory. Jones was also arrested; luckier than his organizer, he managed to escape, and was back in England in the autumn. Rafferty concealed his nationality for many weeks, and behaved with exemplary courage when the Germans eventually discovered it; he gave nothing and nobody away. They shot him at Flossenbürg late in March 1945.

Pursuing Rafferty's fate has led the narrative to the mountains of Bohemia; it must be brought back to the Pyrenees, where Sevenet was still active till July. After a hazardous escape and a refresher course he was parachuted back, blind, on 15 September, and Despaigne came by Lysander a few days afterwards to work his wireless; they set DETECTIVE up in a smaller area this time, round Carcassonne. Their western neighbour, WHEELWRIGHT, was already flexing its muscles for the triumphs of 1944. George Starr's cover, as a retired Belgian mining engineer who had made his pile in the Congo, was impeccable; it covered the inimitable eccentricities of his accent, which was certainly not French. In Castelnau-sous-l'Auvignon people took to him so much that he was made deputy mayor – more excellent cover; his only troubles were over communications. Late in August he got at last a wireless operator of his own. Mme Cormeau (*Annette*), a perfectly unobtrusive and secure craftswoman who transmitted, over the next twelve months, just 400 messages for him – almost as many as Floiras sent for Cammaerts in a rather longer spell. She broke one of the strictest rules of wireless security – i.e. always keep on the move – with success: she transmitted for six consecutive months from the same house. She could see for three miles from the window where she worked, which was one safeguard; a more effective one was that there was no running water in the village, so the Germans who knew there was an English wireless operator somewhere close by never thought of looking for her there. Starr made plenty of trouble for the Germans, and specialised in attacks on communications, with good results. 'The HQ of Army Group G (Blaskowitz) near Toulouse was at times cut off' from the rest of France, according to von Rundstedt, by the end of the year. 'It was only with a strong armed escort or by aircraft that they could get their orders through to the various armies under their command. The main telephone lines and power stations were frequently out of order for many days.'¹²⁸

To complete the tour of F's work in France this year, we need to consider the regions round Lyons, Dijon, and Belfort. PLANE faded out early; Le Chêne wound this small circuit up and came out through Spain, leaving his wife in a safe house whence she could do occasional courier tasks for SPRUCE. GREENHEART, the Newton brothers' projected circuit in the Puy-de-Dôme,

closed down also, in noisier circumstances. Surrounded to the end by intrigues they were too honest to fathom, 'the twins' got in touch with an escape line through Alan Jickell, who was equally out of his depth; he came to collect them from Lyons for the journey to Perpignan a day too late. Just as the Newtons had finished a farewell dinner with their two most trusted French friends, they were literally overpowered – four against fifteen – by a Gestapo party that stormed into their small room. Torture only made them hate the nazis more; they remained silent on anything that mattered. The Germans' attention was distracted away from pressing them on points of importance into futile attempts to resolve the one point where the brothers contradicted each other: each said their parents had been killed in an air raid; one put it in London, the other in Manchester. In the end they went to Buchenwald; they, Burney, and Southgate were the only surviving British agents left in the camp when it was liberated.¹²⁹

Boiteux got SPRUCE safely out into the hills north-west of Lyons in January, to run as a country instead of a town circuit: he received nearly a score of arms drops, and was able to do a little useful railway and canal sabotage to supplement PIMENTO'S. His followers liked and trusted him; but he was not really satisfied that he had built up a sufficiently small and secure circuit. Late in the summer he returned to England, and the area was taken over by three separate organizers: Robert Lyon, one of de Guéllis's early discoveries, who came to take over from him after training in England; one of his friends from the Lyons FTP, Marchand; and Eliane Plewman's brother Albert Browne-Bartroli. Lyon arrived by Lysander on 23/24 June to set up ACOLYTE, and had J. H. Coleman¹³⁰ to help him from mid-September. They found the neighbourhood so sternly policed that they could do no effective sabotage, for the time being at least; so they settled down to spend the winter arming and training a secret force of fighting men who would come out and fight when Lyon gave the word: the sort of force the French called *sédentaires*, perfectly efficient so long as they got their training regularly. Lyon saw to it that they did. Marchand's NEWSAGENT had similar experiences.

Browne-Bartroli's DITCHER, a little farther north, was not quite so cramped in by the enemy, but did nothing spectacular yet. This was a contrast with ACROBAT, the short-lived second mission of John Starr (*Bob*). When Starr parachuted into Burgundy in May, conscious of the high place he held in F section's estimation, he soon had it believed in the neighbourhood that he was a powerful figure in the Intelligence Service and would be needing the best of everything. He took with him a technically excellent wireless operator, J. G. Young (*Gabriel*); but Young talked French with so strong a Newcastle accent that Starr had to keep him hidden in a château at St Amour. Diana Rowden joined ACROBAT as courier by the midsummer Lysander. The three of them were shortly joined by Harry Rée (*César*), who had been received by Southgate near Tarbes in April, jumping with Maingard. Southgate, alarmed by Rée's accent, passed him to HEADMASTER; HEADMASTER was

soon in dissolution. Rée moved on to ACROBAT, but disliked Starr's assertive manner, did not fancy the new circuit secure, and was glad to be sent off on a mission by himself towards Belfort; he was not surprised to hear shortly of Starr's arrest, betrayed by a double agent. Starr tried to break away at once, but was shot down and taken to Dijon gaol.¹³¹

Rée's STOCKBROKER thus became an independent circuit; Young had still to lie low in the attractive place Starr had found for him. Cauchi (*Pedro*) was dropped on 14 August to take charge of him; and Rée embarked on one of the most interesting innovations of the war.

Trotobas' attack on the Fives–Lille locomotive works was remarked on a few pages back as economical in lives; real damage was caused for no casualties. Rée now found that circumstances compelled him to invent an improvement in economical attack, a type of attack equally sparing of life that saved time, risk, and trouble as well. His first coup in this new style lacked the bravado of the Fives–Lille raid; but it was quite as cool, the initial risk for the principals was quite as great, and the results were a good deal better. The Peugeot motor-car factory at Sochaux by Montbéliard had been converted to make tank turrets for the German army and Focke-Wulf engine parts for the German air force. To put it out of action would obviously help the allied effort. Though it was on bomber command's target list, it was a small target that would need to be hit precisely if it was to be usefully damaged at all; and it was sited close to the railway station in a populous part of the town, so that near misses on it would probably kill many Frenchmen – as indeed happened when the RAF made an ineffective night attack on it on 14 July. The mean point of impact of the bombs was nearly a kilometre from the factory, in which production was undisturbed; some hundreds of townspeople were killed. Rée knew already from local friends that some of the Peugeot family at least favoured the allies; one of the directors of the firm was in negotiation with him at the time about lending STOCKBROKER some money to be repaid by the British Treasury after the war.¹³² Rée called on him, and suggested that the director might like to help sabotage his factory, instead of facing all the damage that would ensue when the RAF returned to do the job properly. M. Peugeot, naturally enough, asked for some indication that Rée was speaking *bona fide*; at Rée's invitation, he composed a brief personal message which the BBC duly broadcast a few nights later. Convinced, the director sent for the foreman of the tank turret machine shop, and introduced him to Rée. The agent made one personal reconnaissance, and thereafter never set foot in the factory again; but it was out of production for much of the rest of the war.

Baker Street was delighted at this arrangement, and tried to make much use of it elsewhere; but of course it was by now too late in the war to catch on properly. A joint Air Ministry and SOE committee had a dozen meetings during the winter, hunting for targets; but it was just when bomber command was busiest with POINTBLANK, and the omens were from SOE's point of view

inauspicious.¹³³ One satisfactory use of this rare and commendable type of blackmail was made: the Michelin family refused to follow the Peugeot's example and assist in dislocating their tyre factory at Clermont-Ferrand, and the RAF consequently damaged it severely. Rée himself had to flee across the border in November, a bad month for SOE, after a fantastic fist fight with a Feldgendarme who intended to arrest him; but his system remains in being, for economical warriors to work.

One last circuit, also in eastern France, completes the tour for the year: Richard Heslop's MARKSMAN in the Jura and Savoyard alps. Heslop (*Xavier*) was sent to France by Hudson on 21 September, as the English half of an Anglo-French mission called CANTINIER; Rosenthal of RF, a bespectacled dealer in precious stones of marked intelligence and courage, was his companion. He knew the area well, from holiday visits before the war; many local skiing instructors were his friends.¹³⁴ In this well-balanced pair, Heslop provided the daring and the leadership, while Rosenthal designed the strategy of the mission. They spent three weeks in a rapid survey of the area's possibilities; returned briefly to London to report;¹³⁵ and were back in France within 48 hours, bringing a courier and a wireless operator with them to settle down to serious work. Heslop had *mana*, or whatever else you call that mesmeric quality that makes men follow another man thorough flood, thorough fire; he soon assembled a formidable underground army, fit to play its part in the battles to come.

Unluckily for the historian, he was a proverbial strong, silent man, who disliked putting pen to paper. When F section insisted, next year, on a final report from him, it was hardly longer than Caesar's account of his victory over Pharnaces. Most of the details of what Heslop did are now beyond recall; but *Xavier* will be a name of power for centuries in the Alpine hamlets that know him.

X

A Run of Errors: 1943–1944

‘Mit der Dummheit kämpfen Götter selbst vergebens’ – Schiller

Across the uneven tenor of F section’s operations there ran several series of mistakes. The *affaire Grandclément* which rocked de Baissac’s SCIENTIST circuit at Bordeaux was a straightforward case of double dealing, if that contradictory phrase may be used, and is covered in its chronological place; so are some of the divers eccentricities of the CARTE organization, the break-up of the unlucky MUSICIAN and SALESMAN circuits, the downfall of Southgate the overworked leader of STATIONER, and other defeats. In some of these cases part of the blame for what went wrong in the field must be shared by the home staff; London’s share of the blame is larger still in the two interconnected series of mistakes which will be treated in this chapter.

One of these series is complex: basically it consists of the PROSPER-PHYSICIAN disaster, though the misfortunes of DONKEYMAN, BRICKLAYER, CHESTNUT, BUTLER, SATIRIST, CINEMA-PHONO, ORATOR, SURVEYOR, and PRIEST are more or less inextricably entangled with it. The main trouble arose from a combination of bad agents’ security in the field and the successful ‘turning round’ of at least one captive by the Germans; undue gullibility in London made things much worse. Alone, almost any of the many slips made might have been excusable; in combination they were dangerous, and imperilled a small but important proportion of SOE’s work in France. The connected series arose from a single injudicious posting: the head of the FARRIER circuit, whose only task was to organize clandestine air landings for F in northern France, was after the war described by SD officers under interrogation as perhaps the best agent they had had.

The interconnexion between the two sets of mistakes arose because the PROSPER and FARRIER circuit heads knew each other, and often met in Paris, together with their chief lieutenants; several of PROSPER’s agents used FARRIER’S channels. Further confusion has been caused by two coincidences of names. One of the French double agents who helped to betray DONKEYMAN

bore the same name as a senior officer in the Paris headquarters of the Sicherheitsdienst: Kieffer. Worse, a British-trained wireless operator whom the Germans turned round was generally known in the field by his first name, which also happened to be a field name of the head of FARRIER, and was the codename of a large French intelligence network run from Switzerland as well:¹ *Gilbert*. The cries of ‘Gilbert nous a vendus’ so often heard in captured French sub-agents’ families were thus open to misconstruction, and confusion between the two men, from the same accidental cause, was not unknown in London.

The FARRIER case, intricate though it is, is in one way at least simpler than *l’affaire Prosper*, for there is only one central character: H. A. E. Déricourt, a French airline pilot whose career must now be examined in some detail. Which side this man was ‘really’ on has been much disputed in a number of books, in court, and in the French press where *l’affaire Déricourt* provided a major sensation.² The truth is that his only unswerving loyalty was to himself; he was trapped by circumstances between the upper millstone of loyalty to workmates in SOE and the nether millstone of inextricable entanglements with the Gestapo, and did what he could to serve both sides at once.

He was born in France of French parents on 2 September 1909 and made his career as a more than competent civil pilot. He claimed nearly 4,000 hours’ flying to his credit before he joined SOE, and is said to have earned £300 a week at one time before the war as a trick aerobat.³ He was a man of keen and swift intelligence and uncommonly steady nerve, he combined witty turns of speech and a persuasive manner with a flashy taste in clothes; and he was well-known and not disliked in such society as international pilots frequented. Before the war he did at least a little courier work for at least one continental secret service; but he was not in any British one till he entered SOE, and he once said – defending himself against SOE’s suspicions – that he ‘had no previous experiences of underground organization or secret service work’ before FARRIER was launched.⁴ He served in the French air force as a transport and test pilot in 1939–40, and then went back to civil flying; he happened to be in Aleppo when it was overrun by the allies in July 1941. Like several other pilots there, he was offered work by BOAC’s predecessor Imperial Airways; he said that he would like it, but had to revisit France on private business first. He returned there; married; gave his wife a large sum in cash; resettled his family near Paris; and was then ready to escape. The PAT escape line collected him in August 1942; he reached Glasgow from Gibraltar on 8 September and was greeted on the platform at Euston by Dewavrin two days later.

However, he had already made up his mind not to work for the gaullists. He was promptly taken up by F section, although the security authorities reported they could not give him a clean bill, because his journey from Syria to England through occupied France might well have exposed him to pressure to become a German agent. F section’s headquarters staff, with one

exception – and the exception later became one of his strongest supporters – were all delighted at his arrival,⁵ and determined to use him as air movements officer in northern France. He was given parachute and Lysander training (only), and dropped blind into France not far from Orleans on 22/23 January 1943. He rejoined his wife in Paris, where he lived quite openly and under his own name in his own flat; sensibly maintaining that he was too well-known to do anything else. Besides, he was fond of his wife, who was not the sort of woman who would be any good at concealing her identity. His Paris friends thought he had spent the past five months in Marseilles, and his Marseilles friends whom he occasionally visited thought he had spent them in Paris; he did not enlighten either. The only trouble about this arrangement was that his flat, at 58 rue Pergolèse, was separated from Bleicher's at number 56 only by the party wall that divides the two houses. In retrospect, this neighbourhood must suggest complicity; but cannot directly prove it. For Déricourt's dealings were with the SD, and Bleicher belonged to the rival Abwehr; they may only have known each other by sight.

He arranged his first operations through Lise de Baissac and through PROSPER'S wireless operators. The first was near Poitiers on 17/18 March; Claude de Baissac, Antelme, Flower, and a wireless operator left for England, and Goldsmith, Lejeune (*Delphin*), Dowlen and Mrs Agazarian arrived; two aircraft came. On 14/15 April he managed another double Lysander landing, in the Loire water-meadows under the walls of Amboise; Frager, Dubois, and Liewer and his assistant arrived by these aircraft, and Clech left. Déricourt bicycled twenty miles downstream with Frager to Tours, and left him at a school, where the Gestapo almost caught him at breakfast.⁶ The Germans' arrival was in fact an accident – 'It was merely a commission visiting schools' libraries, and examining textbooks in the hands of children to make sure that only the right kind of history should be taught';⁷ but the incident gave Frager a bad opening impression of Déricourt. On the very next night Déricourt received another Lysander, in the Loir (not the Loire) valley, midway between Le Mans and Tours; a DF and an RF agent whose futures did not concern him were the incoming passengers, and he sent out to England Julianne Aisner, later Besnard (*Claire*), who was to work as his courier after training. By the last Lysander he received on this tour he returned to England himself, on London's orders, on 22/23 April; this operation was also in the Loir valley, but farther upstream, some ten miles west of Vendôme. (Two aircraft came, but as he was the only passenger in either direction only one of them landed.)

After a few days' staff discussions⁸ he returned to France again on 5/6 May – during the dark period; parachuting blind once more into the Gâtinais. He saw Suttill off to England on 13/14 May by Lysander from a ground in the Cher valley a few miles east of Tours. Two aircraft took part; Suttill, the only passenger for England, crossed with the newly trained Mme Besnard, who took up her work as Déricourt's courier and Paris cut-out, and with

three agents to re-form INVENTOR as a circuit working alongside DONKEY-MAN. These were Sidney Jones (*Elie*) as liaison officer with DONKEYMAN and arms instructor, and Marcel Clech (*Bastin*) his wireless operator, both on their second missions; and Vera Leigh (*Simone*), the forty-year-old dress designer, as their courier. In training she had more than held her own with the men, and was distinguished as 'about the best shot in the party' and 'dead keen';⁹ her keenness was about to be tested hard.

Déricourt's next operation, a month later (16/17 June), also a double Lysander, was more crowded. The aircraft landed on a particularly fine moonlit night in the Loir valley seven miles northeast of Angers, not far above the Loir's junction with the Sarthe. Three doomed women climbed down the Lysanders' ladders into the meadow grass: Cecily Lefort (*Alice*), courier to JOCKEY; Diana Rowden (*Paulette*),¹⁰ courier to ACROBAT; and Noor Inayat Khan (*Madeleine*), wireless operator to CINEMA, a sub-circuit of PROSPER'S. (*Madeleine* was to have gone to France a month earlier; she had had the discomfort and anxiety of a flight from Tangmere to Compiègne and back in May – no reception had been ready for her.)¹¹ Skepper the MONK organizer accompanied them. Both the Agazarians went back to England in one of the aircraft; Lejeune and two French politicians took the other. In perfect conditions Rymills and McCairns the pilots had not the slightest difficulty; everything went without a hitch.

A week later (23/24 June) Déricourt was back on the Amboise ground, where Verity's Lysander brought him Robert Lyon on his second mission (ACOLYTE), and took away Heslop, who had been eleven months on his first; Lyon was accompanied by the giraudist Colonel Bonoteau, and Heslop by an escaping airman. (This was the night of the main PROSPER arrests.)

In the July moon Déricourt received, at the second attempt, a Lysander on the ground near Tours (19/20), by which Isidore Newman (*Pepe*, Liewer's wireless operator) arrived, and Antelme the hunted BRICKLAYER organizer and his friend Savy left for England; one unidentified person arrived also, and Déricourt himself seized the opportunity for a flying visit to London. André Simon met him at Tangmere, and put him in his own flat near Cavendish Square for the one whole night (Tuesday 20/Wednesday 21 July) that Déricourt spent in England. Of what passed between the visitor and the staff in Baker Street no record remains. Probably Déricourt said as little as he could about PROSPER's troubles, of which he can hardly have failed to know; a taciturnity little to his credit with the British. In all likelihood, most of his few hours in London went on sleep and on essential discussions about pick-up techniques with officers in F and AL sections. Verity took him back to France in a Lysander on the night of the 21/22nd; they landed near Châteauroux, at another service's reception, from which Déricourt removed himself with all speed. He travelled over a hundred miles during the day, crossing the demarcation line as he did so. Next night, the 22/23rd, he received a Hudson on a hilltop north of Angers, sending three Belgians

away by it and receiving Bodington and Agazarian on their mission to investigate the PROSPER disaster, as well as yet another unknown. The pilot reported that ‘This field was found to be most satisfactory. Signalling and flarepath excellent and recommended for further use.’¹² Bodington returned to London early in the August moon (16/17), with Claude and Lise de Baissac, by a Lysander that arrived empty near Tours. Déricourt ran a second operation in August, receiving a Hudson on the 19/20th on his Angevin hilltop; only one agent came in (Deman),¹³ but ten left, including Robert Benoist, Brooks, Octave Simon, and the whole SPRUCE team – Boiteux, Marchand, Regnier, and Mme Le Chêne – from F section and Gerson from DF. This was a more animated operation than usual because the Hudson shared the field with a large herd of bullocks, who stampeded past the terrified waiting agents. On 17/18 September Déricourt handled a pair of Lysanders on the ground north-east of Angers the party of women had used in June; this time another fated woman agent was delivered to it – Yolande Beekman, Gustave Biéler’s wireless operator. Peulevé, launching AUTHOR; Sevenet’s assistant Despaigne; and d’Érainger an RF agent came with her. The six passengers for England were the invulnerable Cowburn; Goldsmith and Colonel Zeller; two Polish couriers; and an old pilot friend of Déricourt’s, M. R. Clement (*Marc*), on his way to a Lysander course in England. Clement returned a month later (16/17 October) by Lysander to Déricourt’s Amboise ground, and took up his duties as FARRIER’S second-in-command; he brought with him A. P. A. Watt (*Geoffroi*) to be the circuit’s wireless operator. (Watt, half French by birth and a journalist by trade, made up in keenness for his marked lack of inches, but concealed his fervour behind a gullible or even foppish appearance. He and the Besnards used to dine out and visit the theatre a good deal in Paris, and an appearance of elegant ease served admirably for cover in a circuit of this particular kind.) The aircraft that Clement, Watt, and another arrived in took Southgate away for rest and re-briefing; it also took to London, for the first time, René Dumont-Guillemet, who was destined eventually to pick up many of the broken pieces of the PROSPER and FARMER circuits and knit them into SPIRITUALIST.

Four days later (20/21 October) Déricourt was at work again, once more on his Hudson ground north of Angers. Browne-Bartroli (*Tiburce*), Eliane Plewman’s brother, was landed on his way to establish the DITCHER circuit in Burgundy; so were Marchand who was to set up NEWSAGENT to the south of him, Robert Benoist to found CLERGYMAN at Nantes, and another. Four people left; one of them was important – Frager, who had had so narrow an escape after his only previous meeting with Déricourt, when he arrived in mid-April.¹⁴ Frager brought Roger Bardet his trusted second-in-command along to Angers with him; this infuriated Déricourt, who said truly enough that it ran against all rules of security and common sense to bring one’s friends along to see one off. Bardet and Frager had both maintained a marked air of mystery on making contact with Déricourt; a sharp quarrel

broke out over dinner near Angers and was carried on at the landing ground. Déricourt was much put out to discover that it was Frager, whose identity he had not (he said) so far discerned, who was to leave, and Bardet who was to remain in France; and accused Frager of having told Bodington in August that he, Déricourt, was an agent of the Gestapo. An acrid discussion followed about whether Déricourt had read some of Frager's correspondence which was to travel by Lysander, and if so why. At this point Frager, who was going to London solely to report his conviction that Déricourt was a German agent, closed his hand on the butt of the revolver in his pocket. But Déricourt changed his tone, asking half-plaintively 'Why do you mistrust me, Paul?';¹⁵ and talked so persuasively that, from the door of the Hudson, Frager turned back to hold out his hand. Déricourt refused to shake it.¹⁶

No such incident took place on the next Hudson landing here (CONJUROR, 15/16 November); the drama was confined to a short scuffle offstage. Another party ten strong went off to London, including Cammaerts, Chartrand, and four friends of Cowburn's, Mulsant, Barrett, Rechenmann, and Mme Fontaine. The pilot, commenting on the excellence of the reception, described this as 'a very straightforward operation'.¹⁷ The arrangements for it had been less straightforward; the Germans were fully aware of what was going on, and did their best to trail and capture the five incoming agents. One of these, Gerson on his third mission, would have been a brilliant prize; but he was far too competent at effacing himself, and promptly gave his followers the slip. He went down to Lyons and resumed charge of VIC. Levene, formerly a SCULLION, also evaded arrest for a few days; he was on his way to join DONKEYMAN as arms instructor, and was in no particular hurry to arrive. Bleicher arrested him at a *brûlé* contact address in Paris at the end of the month. The other three arrivals, Maugenet, Menesson, and Pardi, had a shorter run. They were tailed to the station; sat in separate compartments on the train to Paris, to the inconvenience of their two shadows; joined up again on the platform at the Gare Montparnasse; and were instantly arrested.¹⁸ Menesson, on his second tour, kept silent; so did Pardi, who was to have received Lysanders for de Baissac. But, put under pressure, Maugenet (*Benoit*)¹⁹ seems to have talked; certainly there were deplorable consequences to STOCKBROKER. His orders were to join Young and Diana Rowden, neither of whom had ever met him; and the Germans sent an agent to impersonate him round Lons-le-Saunier. The impersonator established his *bona fides* by handing Young a letter from his wife and then went off to fetch his friends, who arrested the unsuspecting Young and Diana Rowden easily.²⁰ There is even an ugly rumour that Maugenet did not need to be impersonated, as he did the job himself.²¹ Nothing in his own file confirms this. Possibly this is the incident Roger Bardet once referred to in confessing his work as an Abwehr agent; he said the Abwehr lent him to the SD in order to facilitate penetration of an unnamed resistance organization by

impersonating an agent newly arrived from England.²² A difficulty about linking the lending of Bardet with the betrayal of Young and Miss Rowden is that Bardet was barely half Maugenet's age and unlike him in appearance; but that letter from Mrs Young would be introduction enough.

Almost simultaneously, the axe fell on INVENTOR; this time undoubtedly by Bardet's agency. Sidney Jones's courier Vera Leigh and *Jacky* his bodyguard were arrested when they met in Paris on 30 October, and Jones himself followed them into custody about 20 November. A number of contradictory accounts of these arrests are in print. Vera Leigh's file shows that Clech reported her arrest a few days after it happened;²³ Bardet placed the incident at the 'Chez Mas' café in the Place des Ternes,²⁴ which was one of Déricourt's routine rendezvous. She was probably too well known to the enemy by sight: Bleicher in a boastful mood said after the war that 'as a matter of fact, she had lodgings quite near me, for months I would watch her tripping along the pavement in the morning, so busy, so *affairée*. She was of no interest to me; so long as she kept out of my way, she could play at spies.'²⁵ This may well be invention; but certainly she was unlucky in the flats she chose to live in, which were right on the Gestapo's doorstep. One where she spent several weeks was in the rue Lauriston, a few doors from the headquarters of the Bony-Lafont gang;²⁶ one of the least agreeable bodies in the Paris underworld, and another in the rue Marbeau round the corner from the SD offices in the Avenue Foch and Bleicher's own flat. In any case, she and the bodyguard were caught; three weeks later Sidney Jones joined them behind bars; and Clech was added to them a month after that. This last arrest may have been due to wireless direction finding and not to betrayal; Jones like his courier was betrayed by Bardet to Bleicher. None of them came back.

Just possibly these arrests derived from some degree of jealous feeling between the Abwehr and the SD;²⁷ more probably they were undramatic routine police operations; in either case, the victims had no chance. However, there was plenty of drama on the next of Déricourt's own operations on the Angers Hudson field. This was to have taken place in the December, and then in the January moon; but it was not till 3/4 February 1944 that weather allowed the aircraft to arrive. By this time all Déricourt's safe houses within bicycling distance of the ground had been used and over-used to the limit of prudence: for he had six agents waiting nearby on the run from the enemy, Liewer, Maloubier, Borosh, Robert Benoit²⁸ and Madeleine Lavigne among them as well as Mme Gouin the politician's wife, and the splendid woman who ran the country restaurant he had hitherto used as the assembly-point for his Hudson parties. (Two more agents, Vallée and Gaillot trying to escape from the wreck of PARSON, were picked up by the Gestapo on the evening of the 3rd, as they were leaving Paris to join the rest; who betrayed them is obscure.) Déricourt had been warned through the BBC to expect ten incomers; and Clement, Pouderbacq his pre-war mechanic and he formed the whole reception committee.

The Hudson arrived; with only one passenger in it, who had no intention of remaining in France. This was Jerry Morel, still F section's operations officer, who had been sent over with orders to bring Déricourt back with him; such were the suspicions that Frager's and other denunciations in London had by now aroused. (Hence no doubt the operation's codename: KNACKER.) But Déricourt was too adroit for him. While the waiting agents emplaned, he explained to Morel with the utmost charm that the ground could not be used again for months – it 'was very much blown and he was quite firm in stressing that it would be most dangerous to use it again for a very long time';²⁹ but that its security would be hopelessly compromised if he did not remain behind to help his two assistants dispose of thirteen bicycles before dawn. (If it struck him, as it should have struck Morel, that there was room in the Hudson for the surplus bicycles, he said nothing about it.) He even stepped into the aircraft to confirm an appointment to have himself picked up by Lysander on the following Tuesday; 'had I wished to retain him there by force', Morel reported, 'there would have been no difficulty in doing so', but the staff officer's judgement failed him and Déricourt stayed in France.³⁰

Punctually next Tuesday night, 8/9 February, he greeted a Lysander on the old ground east of Tours. Lesage and Beauregard, who were to establish the LACKEY circuit in Burgundy, arrived by it; Déricourt was expected to leave alone. However, he summoned a figure from the darkness and ushered her up the Lysander's side before him; though she had no connexion with his circuit beyond being married to him, he was not going to leave his wife behind in danger. They had an uneventful flight to Tangmere.

In sum, he had conducted seventeen operations involving twenty-one aircraft, during just over a year of clandestine activity: 43 people had, entered and 67 (himself twice included) had left France under his care.

It may be convenient to have them set out in a table; see p. 266.

This was a reasonably, indeed a distinctly good record; though nothing like as good as the inflated claims made for Déricourt at his trial.³¹ At Buckmaster's prompting, Mockler-Ferryman put him up for an immediate award of the DSO, on account of his 'great ability and complete disregard of danger', in 'particularly difficult and highly dangerous' circumstances which involved 'keeping up many very dangerous acquaintances, particularly with pilots of the Luftwaffe and Lufthansa'; as will appear, the brigadier wrote more wisely than he knew. Word of this leaked back to Déricourt, and he put up the ribbon, but never received the award. Doubts about which side he was really on became so prevalent early in 1944 that the Air Ministry had to be asked to suspend action; the citation was never gazzetted. All the same, Déricourt later told the French he held it, as well as two French decorations and a Polish one. It is worth noting a few comparative points. During Déricourt's missions three other landing operations were carried out for F section, and twenty for RF. Though he handled more pick-ups than

TABLE III: PICK-UP OPERATIONS CONDUCTED BY
HENRI DÉRICOULT (*GILBERT*)

<i>Date</i>	<i>Place</i>	<i>Aircraft</i>	<i>Passengers to</i>	
			<i>France</i>	<i>England</i>
<i>First Tour</i>				
17/18 March 1943	South of Poitiers	2 Lysanders	4	4
14/15 April 1943	Amboise	2 Lysanders	4	1
15/16 April 1943	Nr Château-du-Loir	Lysander	2	1
22/23 April 1943	West of Vendôme	2 Lysanders (1 landed)	—	1
<i>Second Tour</i>				
13/14 May 1943	East of Tours	2 Lysanders	4	1
16/17 June 1943	NE of Angers	2 Lysanders	4	5
23/24 June 1943	Amboise	Lysander	2	2
19/20 July 1943	East of Tours	Lysander	2	3
<i>Third Tour</i>				
22/23 July 1943	North of Angers	Hudson	3	3
15/16 August 1943	West of Vendôme	Lysander	—	3
19/20 August 1943	North of Angers	Hudson	1	10
17/18 Sept 1943	NE of Angers	2 Lysanders	4	6
16/17 October 1943	Amboise	Lysander	2	3
20/21 October 1943	North of Angers	Hudson	4	4
15/16 Nov 1943	North of Angers	Hudson	5	10
3 / 4 Feb 1944	North of Angers	Hudson	—*	8*
8 / 9 Feb 1944	East of Tours	Lysander	2	2
	Totals:	17 Lysanders) 5 Hudsons)	43	67

Note: * One staff officer, omitted from figures, took part in this operation and set foot in France for a few minutes.

any other SOE operator in France, Rivière (*Marquis*)³² of RF was not far behind him, with eleven to his seventeen, and moved more bodies – 52 into France and 80 across to England. In all, Déricourt conducted a fifth of SOE's 81 French pick-up operations, while nearly a sixth of the passengers passed through his channel.³³

But what were the suspicions that made F withdraw him to England, and were they justified?

Doubts began in June 1943, with a report from Agazarian that Suttill thought Déricourt's security faulty.³⁴ In July messages from several circuits indicated that 'Gilbert is a traitor'; but these were ambiguous, as more than one Gilbert was in France (in the autumn Déricourt's field name was changed to *Claude*, but most people who knew him already continued to call him *Gilbert*; this did not make confusion less confounded). One at least of Déricourt's August passengers reported that he thought the security arrangements of Déricourt's circuit, both in Paris and round Angers, woefully defective. Frager also told London of his suspicions. He was handicapped in doing this

because Clech his new wireless operator was by a bad staff blunder sent to France without any ciphers, and then by a worse blunder provided with a copy of the ciphers he should have brought, which Frager had – wrongly, but in good faith – reported handed over to the Germans by a member of FARRIER who had charge of Clech’s suitcase. In the end, in October, Frager crossed to England with the declared ‘primary object’ of arraigning Déricourt as a traitor. He reported that a mysterious ‘Colonel Heinrich’, in fact that same Sergeant Bleicher of the Abwehr who had been Mathilde Carré’s lover and arrested Peter Churchill, ‘stated definitely that *Gilbert* was working for the Germans’. This, said Frager, made him reconsider various small events of the summer, such as the sudden arrival of German AA units on two of his dropping zones west of Paris which he had reported to London by courier through Déricourt. When Bodington was in Paris in July and in frequent touch with Déricourt, Frager had imparted his doubts to him; but Bodington had brushed them aside, feeling intelligibly enough that as he was not arrested himself, the people he saw must all be sound. Frager remarked that he ‘is convinced that the Colonel [*Henri*] was not lying and believes he spoke the truth when he said that the Germans had decided not to arrest Major Bodington, as they did not want to ruin one of their best channels of information – *Gilbert* ... “l’homme qui fait le pick-up”’.³⁵

It is unclear why Bleicher let out this important piece of information. He mentioned it early in August, during a chat over a few drinks with Bardet and Frager, who posed as Bardet’s uncle, not realising that Bleicher knew perfectly well who he was. Bleicher mentioned in the same conversation that his own service, the Abwehr, was engaged in a ‘struggle to the death’ with the Gestapo.³⁶ Possibly SOE’s Paris circuits were being employed as unconscious pawns in the struggle between the Abwehr and the SD, which was by now acute, and Bleicher hoped an indiscretion might endanger a valuable SD source; but this would be an oblique and inefficient way of feeding the indiscretion back to the British. He said afterwards his main anxiety was to keep Déricourt and Frager hostile to each other, because Frager was so useful to himself.³⁷ More probably, he was simply talking carelessly.

Buckmaster and Morel did their best to countervail these charges and to put them down to Frager’s undoubted excitability. But the charges were reinforced from other quarters. In particular, one of Déricourt’s opposite numbers in RF section, Georges Pichard (*Oyster*), was reported to have good reason to believe that ‘a Frenchman holding a commission in the British army ... in charge of air operations in the Paris and Angers districts’ had betrayed to the Germans ‘two men and a woman, who were landed sometime in August, [and] were picked up by the Gestapo very shortly after their arrival.’ So KNACKER was mounted, after dubious consultations with the Air Ministry,³⁸ and Déricourt was recalled. Obviously, he had reached a fair degree of eminence in F section, though like Peter Churchill he had himself performed no acts of sabotage at all, for it was no part of his job to do so. The

possibility that he was on the wrong side had to be treated as a matter of extreme secrecy. In the staff stratosphere, it was handled above AD/E's head by Boyle, the director of intelligence, and Gubbins's other principal deputy Sporborg. (During the critical weeks of decision on this point, in February 1944, Gubbins was out of the country.) Sporborg on first hearing the case rather favoured Déricourt; his lawyer's training made him unable to overlook the lack of direct proof of guilt, and helped him to see how flimsy much of the circumstantial evidence was. However, the security service weighed in with a strongly hostile opinion:

Although it is only fair to say that *Gilbert* makes a good personal impression under interrogation, and that his antecedents seem to be unexceptionable, we should, if the decision were entirely [ours], regard the case against him as serious enough to prevent him undertaking any further intelligence work outside this country. In view of the facts indeed we feel that this is the recommendation which we must make.³⁹

In face of this, Sporborg soon withdrew, and it was decided on 21 February that Déricourt should not be allowed to go back.

All F section's officers continued to back him and to resent his restriction to British soil; Buckmaster kept stressing that no casualties were traceable to him and that this proved his innocence. SOE's chief security officer for one was more cautious: 'the fact that casualties do not appear to have occurred⁴⁰ does not necessarily disprove his treachery', as the Germans might be waiting till nearer D-day before they pounced; but 'if, in fact, he has been working for the enemy (as had been alleged), then he is a high-grade and extremely skilful agent and no amount of interrogation will shake him'.⁴¹ Morel said he was 'absolutely revolted' at the ban on Déricourt's return to France,⁴² and Buckmaster delivered himself of a series of peppery minutes about interference with one of his best circuits by people who did not understand conditions in the field. As late as 21 May he was arguing that Clement's continuing immunity proved Déricourt's innocence; and after the war the head of F section recorded this glowing testimonial:

It is indelicate to say what I think about this officer, as long as his case is *sub judice*. But when – if ever – the clouds are blown away, I am prepared to bet a large sum that we shall find him entirely innocent of any voluntary dealing with the enemy. His efficiency in Hudson and Lysander work was staggering and it was his very success that raised the ugly idea that he was controlled. People who did not know him and judged him on the results of his work said 'It's too good to be true – he MUST be a bad hat'. That kind of reasoning would of course be scoffed at by any country section officer who has to judge his man far more closely than an outsider.

Suffice it to say that he never once let any of our boys down and that he has by far the finest record of operations completed of any member of SOE.⁴³

But what in fact had actually happened? Déricourt gave two different accounts of what had passed, one to the British in 1944 and another to the French in 1946; the conflicts between them, and the evidence from the other side, provided ample grounds for suspicion, though few for proof. It is clear that at some stage he was in close contact with the Gestapo; Goetz went so far as to record a dinner at Boemelburg's flat on 5 February 1944, at which Déricourt was the only other guest, and the subjects discussed were what to do about London's orders to Déricourt to return and what missions Déricourt should perform for the Germans if he did so.⁴⁴ Déricourt's story was that two acquaintances from before the war, German pilots who had become Luftwaffe officers, called on him unexpectedly at his flat in the late spring of 1943 and introduced him to a third man who took him for a drive in the Bois de Boulogne. As they drove the third man introduced himself as Dr Goetz, the wireless expert of the SD, recounted Déricourt's clandestine career in detail – his escape from France, his parachute re-entries, all the aircraft he had so far handled – and invited his collaboration. Déricourt, feeling himself 'more or less a prisoner', agreed to co-operate; with – he said – substantial private reservations.⁴⁵ Had he been to Beaulieu he would have known his duty: to get out of Paris, straight away that day, the moment Goetz let him out of his sight, to feed himself on to a DF line, and to get back to London as soon as it could carry him there. Mme Déricourt's inability to travel suddenly in disguise, and his devotion to her, prevented him from doing this; for had he fled, she would certainly have been picked up by the SD who would not have hesitated to torture her. So he stayed.

French readers will remark that that suffices as explanation, but not as excuse. Men and women of complete integrity in the resistance world had steeled themselves to risk the torture not only of their own bodies, but of their most beloved relations,⁴⁶ sooner than betray the cause of France. *Ghisleberto aliter visum*: that is, Déricourt thought he knew better. Few people can say with confidence, putting themselves in his place, that they would have done much better themselves at the start of his long-drawn negotiations with the SD; but he might have disentangled himself much more briskly than he did – for instance, he could have sent his wife out of the country on his next operation. Nor need he have capitulated when Goetz tried on him one of the oldest tricks in the counter-espionage trade, suggesting to him that everything about him was known, and passed on to Goetz as much as he knew about SOE's organization in England. After the war, he told the French he had done this; when they asked whether he had subsequently reported this to the British, he replied that he had not, because he had not been asked about it, and found the suspicious atmosphere of his reception in London

‘unfavourable to explanations on the subject. As the English weren’t in the know, I preferred to leave them in complete ignorance’.⁴⁷ He may in fact have said something to London before his return, though probably not much; for Bodington pencilled on an office note of 23 June 1943 that bore on a reported indiscretion of Déricourt’s before he left, ‘We know he is in contact with the Germans and also how & why.’⁴⁸

The precise extent of Déricourt’s collaboration with the Germans remains uncertain. It is clear from interrogations of members of the notorious Rue Lauriston gang of Paris criminals, headed by Bony and Lafont, that gangsters were habitually hidden round Déricourt’s landing grounds in the summer and autumn of 1943, with the task of trailing the agents who arrived. Goetz even claimed, interrogating Culioli, that he had himself watched Noor Inayat Khan’s arrival by Lysander, as well as assisting at a Hudson operation; but as Culioli had the sense to realise at the time, there was no reason to believe him; he just wanted to impress on his prisoners that he knew everything already.⁴⁹ The arriving agents were not normally arrested at once, as this would presumably have alerted London to some degree of insecurity in FARRIER; in any case, the gang was so incompetent, and most of the agents were so alert when first they arrived to spot that they were being followed – as Déricourt once put it, ‘they arrived ready to deny their own existence’ – that the net gain to the German counter-espionage service from this arrangement was probably small. An exception must be made for CONJUROR, the November operation that put four F agents into German hands.

German intelligence services did better out of intercepted reports from the field, which they certainly saw, and saw by Déricourt’s agency. When challenged on this point, he made the evasive reply that even if he had made correspondence available to the Gestapo, it would have been worth it for the sake of conducting his air operations unhindered.⁵⁰ He did his best to blame this indiscretion on Roger Bardet, who had – or should have had – no access to PROSPER papers, and on Gilbert Norman, who did; Bardet and Norman⁵¹ both blamed it on Déricourt. Whoever supplied these papers, the essential point about them is that the agents who wrote them were so blindly trustful of their colleagues that most of them were in clear – names, place-names, addresses, everything. But more of PROSPER’S insecurity later: let us finish with FARRIER first. After the war, when various members of the Paris SD staff were interrogated, a more formidable case against Déricourt could be built up than had been possible in 1944, and in November 1946 he was arrested by the French on the strength of one particular allegation by a captured German – of which in all probability Déricourt was innocent. This concerned codes for BBC messages. The ADC to Reile, formerly head of the Abwehr’s Ast III F in Paris, produced the tale that thanks to *Gilbert* ‘the SD knew in advance how the different phases of the invasion would develop. Thus, Kieffer of the SD rang me up on 5 June 1944 to let me know that the landing was imminent, asking me in my turn to inform the supreme

commander in the west, Marshal von Rundstedt. I telephoned to this superior officer immediately and informed him that the disembarkation was going to begin that night'.⁵² The ADC had probably got muddled between the Gilberts – 250 BBC action messages are said to have been in Gilbert Norman's wallet when he was taken prisoner⁵³ – and it was no part of Déricourt's task as a pick-up organizer to have any knowledge of operational action messages. Careless as many of F's agents in France in 1943 had been, they would hardly have been so careless as to pass on to someone outside their circuit what their operational action messages were; and in any case all the D-day action messages were altered after Déricourt had left France.⁵⁴

The French gave him, as was his right as an officer, the choice of a civil trial – from the verdict of which either side could appeal – or of a military one, whose decision would be final. He chose the latter; and appeared in court in June 1948. He had to face a whole string of charges of intelligence with the enemy, which were whittled down as the trial proceeded, and his astute defence counsel was able to demonstrate that though the prosecution could bring plenty of suspicious indirect evidence against him, they could not actually pin any definite act of treachery on him. Bleicher, for example, could only testify that he had heard that Déricourt was an important SD agent; he could not, or at any rate did not, of his own knowledge prove it. Nor did he reveal in court that he had been Déricourt's next-door neighbour. Even Goetz could only bear witness to the friendly relations that appeared to his own eyes to have existed between Déricourt, Kieffer, and Boemelburg; he could not himself testify to any specific act of treachery by Déricourt. (Kieffer by this time was dead, hanged by the British for ordering the execution in plain clothes of a group of uniformed SAS prisoners; and Boemelburg had disappeared, believed killed in an air raid in Holland.) The last charge left was that Déricourt had not reported rapidly enough to his superiors that he was in touch with the Germans; and this was disposed of by Bodington. Bodington testified that he had been in charge of all Déricourt's work in the field, which was formally, but only formally true – they had been together in Paris for a few weeks while he was a temporary major and Déricourt was an honorary flight lieutenant; both were equally under Buckmaster's orders. He said also that Déricourt had reported to him that he had been trapped into contact with the Germans; there is no remaining trace of any such report except for the few lines in pencil in Bodington's hand referred to just now. He also maintained that he had authorised Déricourt to remain in contact with the Germans; this was beyond his powers, or Buckmaster's, and no such consent was ever given by the competent authority in London.⁵⁵

Asked by the judge whether he would again trust his life to an operation by Déricourt, Bodington replied 'Certainly, without hesitation'; and on the strength of that evidence Déricourt was acquitted. To sum up, that Déricourt did in fact engage in conversations with the enemy secret police, over a period

of several months, is undisputed. The court that tried him (believing wrongly that Bodington was an official emissary from SIS; he had in fact appeared as the personal friend of the accused) found on evidence that it had no reason to suspect, that he had done so under orders, and was therefore not a traitor. The reader must make up his own mind, on the evidence laid before him here; to which one more item needs to be added. Notoriously 'what the soldier said' would not pass for evidence in an English court of law; but history has different standards and a wider range, and must take note of what Boemelburg said to Goetz in Placke's hearing of the news of Déricourt's flight to England: 'Ah well, that's four millions down the drain.'⁵⁶

FARRIER, though bereft of its leader, survived for a few weeks in conditions that are worth notice; for they show how much a single man had brought danger into its activities. Clement's security had always been impeccable, and the Germans do not seem to have found out who he was or where he lived (this tells in Déricourt's favour); though they must have known well enough how he worked. Through Mme Besnard and Watt and a rigid system of cut-outs he was still available to London for further operations.

In the end the circuit was wound up, through a ludicrous incident that showed how effective its precautionary system could be. In the previous August, Bodington had sanctioned the buying of a small bar at 28 rue St André des Arts, near the Place St Michel. It did little business; its function was to be the open end of a section escape line that would run back to England by FARRIER'S aircraft, and occasionally it carried passengers anxious to leave. Early in March a couple of apprehensive-looking strangers came up to the bar, and one of them delivered half the password in a noticeably Germanic accent. It should have been 'je voudrais parler à la patronne – de la part de ma tante à Marseille'; but he got stuck at the pause. The puzzled barman prompted him, and he finished the phrases correctly, but said surely the barman, not he, should have mentioned Marseilles? The barman went off to telephone Mme Besnard, who agreed with him the whole incident was suspicious; he came back and said firmly the *patronne* was unavailable. His customers grew more insistent, and one of them said they came 'de la part de Toinot, qui doit s'évader vite'. The barman had never heard the name, and took for granted he was talking to German agents, he said firmly they must have come to the wrong bar, this was a respectable house; and they left. Two days later another stranger, with a similar accent and a scar on his cheek, came in; gave the password correctly; said he was Toinot, and badly needed a Lysander; and when could he have one? The barman again rang up Mme Besnard, and they agreed this must mean the Gestapo was closing in on the circuit. The bar shut; the Besnards left Paris that afternoon for the country, and Watt joined them as soon as he had made the necessary contact with Clement and sent a signal to London that they were closing down at the next operation. Watt and the Besnards came to England by one

of Rivière's Lysanders, from the ground east of Tours, on 5/6 April, and Clement on London's instructions lay low.⁵⁷

Next day there also arrived in England, by a routine service escape line he had managed to find, an Alsatian RF agent who had been working near his home and had had to withdraw with two local companions when that difficult area got too hot for him; he complained, among other things, that he could get no response to the correct password in the Rue St André des Arts. His field name was *Toinot*.⁵⁸

Luckily this incident led to no casualties; the only serious loss was that of Clement's excellent services as a pick-up manager, and by this time F had several other Lysander-trained agents in the field. It is easy enough to see how Bodington led F section into the original step of setting up a private section escape line terminus at the Rue St André bar; he was already a strong admirer of Déricourt's, and thought the rest of the section's agents needed the opportunity of taking a FARRIER aircraft home instead of embarking on the long trek across the mountains to Gibraltar and London, with all the probabilities of delay that trek entailed. In any case, there were perfectly sound staff reasons for providing a point of contact in the field for a secret air line home, if pick-ups were to be operated at all. It is harder to see how an RF agent heard of this private line; it was not because some F agent who should have kept his mouth shut gossiped. His interrogation showed that he was put on to it on orders from London, which should of course have gone to Watt also. He found the service escape line he eventually used through the channel of careless talk: a friend of his knew one of the escape réseaux.

Careless talk leads us to the still more complicated, simultaneous series of disasters that overwhelmed the PHYSICIAN-PROSPER circuit. Its growth has been noted in the last two chapters; it is time to consider its fall. The break-up of this organization has been much publicised, principally by people who have no idea of its place in the true perspectives of French resistance and special operations; 'nothing makes for more chatter than ignorance', as Burney remarks.⁵⁹ Let us now try to see it in its proper proportions.

It is said to be widely believed in France that Suttill's circuit was deliberately betrayed by the British to the Germans; even 'directly by wireless to the Avenue Foch'.⁶⁰ An assertion as absurd as this last one calls to mind the Duke of Wellington's reply to the man who called him Captain Jones: 'Sir, if you can believe that, you can believe anything'. The Avenue Foch could only be reached by wireless by someone who knew the frequencies it used; it was the task of one of the British intelligence departments to hunt for these frequencies and, having found them, to watch the traffic on them. It is not seriously conceivable that any transmission could have been made to the Gestapo direct from any British-held set without giving rise to widespread and elaborate inquiries involving several different secret services: how on earth could they all be hushed up? Such a conspiracy to betray PROSPER, whether *per impossible* by wireless or by any other means, appears in any case quite

pointless. What object useful to British strategy could have been served by it?

Only one conceivable object has ever been hinted at in print: that this circuit's downfall may have been part of some elaborate deception scheme to draw the Germans' attention away from the invasion of Sicily; but not in a form that carries conviction.⁶¹ Authors might have inferred from Ewen Montagu's *The Man Who Never Was*⁶² how professional a job was made of planting false information on the enemy for just this purpose; to send a few SOE agents into France primed with rumours that France was going to be invaded in 1943, on the off chance that some of them would fall into German hands and pass the rumours on, would have been a project lacking alike in bite, finish, and viability. Besides, it is undoubtedly the case that, STARKEY apart, no use was made of SOE's work in France for any purposes of deception, then or later: no one trusted the agents enough for such delicate tasks. It was originally Hitler who believed, or at any rate hoped, that the break-up of the PROSPER circuit – of which he too exaggerated the importance – represented a serious setback for the Anglo-American plans to liberate France. Interrogations of captured SD officers made it clear that he took a good deal of personal interest in F section's repression;⁶³ as usually happens when high commanders start interfering in detail, he got his perspectives wrong. In fact of course PROSPER'S troubles had no impact whatsoever on the decision about when the invasion should take place, which was made on other and weightier grounds.

Chapter xi of Buckmaster's *They Fought Alone* does begin with the remark that 'In the middle of 1943 we had had a top secret message telling us that D-day might be closer than we thought. This message had been tied up with international politics on a level far above our knowledge and we, of course, had acted upon it without question.' His orders, as he remembered them many years afterwards,⁶⁴ had been to accelerate his section's preparations to support an invasion, in case it turned out possible to mount one after all later in the year. This possibility was widely canvassed at the time, for it was politically attractive, especially on the far left; but it turned out logistically impracticable. Suttill, in any event, was sent back to Paris from London in late May 'with an "alert" signal, warning the whole circuit to stand by';⁶⁵ this alert may have resulted from some misunderstanding between the section staff and himself about the probabilities of an early major allied landing, or he and the staff may both have suffered from the same misapprehension. Only a few people, in the innermost circles of Westminster and Washington, then knew certainly how small the chances of making such a landing were; and Suttill returned to clandestine duty in the belief that an invasion was probably imminent.

There is a long-standing rumour that he had had a personal interview with Churchill, who gave him a misleading brief on purpose; this is baseless, as a look at the dates makes clear. While Suttill was in England in May 1943, Churchill was not; they cannot have met.⁶⁶

Alternatively, there is a *canard* circulating in France that Suttill threatened when in London in mid-May 1943 that he would call all the resisters he could reach out into open warfare on the first of July if the invasion had not taken place by then; and that he was betrayed to the Germans – through means unspecified – by the crafty British high command, which knew all along it would not be ready yet.⁶⁷ The fatal flaw in this story is that it does not explain why, if the first half of it were true, Suttill was ever allowed to return to France at all.

The truth is that PROSPER's downfall, tragic as its consequences were, was brought on in spite of their bravery by the agents' own incompetence and insecurity. The circuit snowballed; its growth made catastrophe certain, and it was only a matter of time and chance before either one of the new untrained French contacts slipped up and fell into German hands, or someone changed sides, or the Germans stumbled on some fatal indiscretion, as in fact they did. From the start it had been poisoned, for Suttill's first contact in October 1942 had been supplied by the notoriously insecure CARTE organization, which the Germans penetrated thoroughly in the spring of 1943: Germaine Tambour, the point of contact, in whom Suttill expressed great confidence in his first written report,⁶⁸ was arrested in the third week of April – betrayed, in all probability, by the notorious Roger Bardet. Suttill himself, Amps, Norman, Andrée Borrel, and Peter Churchill had all used her house as a letter-box and rendezvous; all of them but Churchill had used for the same purposes another flat in the same building, and so had Agazarian and his wife, Cowburn and Barrett, Biéler and Staggs.

Ten agents in contact with one confidante was bad enough: there were worse errors. Jack Agazarian (*Marcel*), the handsome and dashing young airman who was Suttill's second wireless operator, had been ordered to 'refrain from contacting members of any circuit apart from your own'.⁶⁹ Nevertheless, when withdrawn in June 1943 because he was too conspicuous, he claimed to have transmitted for no fewer than twenty-four different agents, whose field names he gave. Two of these were in fact the same man lurking behind two pseudonyms – Clech, Frager's wireless operator, who could not for a time transmit himself; and Agazarian's failure to perceive this is some tribute to Clech's security. The rest included Biéler, Antelme, Trotobas, Grover-Williams, and Claude de Baissac, quite separate organizers who would have had quite separate communications, had the shortage of trained operators not been so acute; as well as several of Suttill's subordinates and the staffs of the BUTLER and JUGGLER circuits Suttill was helping to launch; Déricourt; and Lejeune a giraudist who had little and two VIC line sub-organizers who had nothing to do with F section's business at all.⁷⁰ What in fact was happening was that many of F's agents near Paris, particularly the PROSPER ones whose work centred on the capital, were congregating there; in defiance of such security training as they had received, in defiance of elementary prudence as well, but in response to the desire for companionship with people who

could share with them the secret of their identity and their mission. They made an intelligible, pathetic error; most of them paid for it with their lives.

Organizers were supposed to keep apart from their subordinates, who in turn were supposed to keep apart from each other, except when the necessities of work brought them together; but Suttill, Gilbert Norman his more efficient wireless operator, and Andrée Borrel their gallant and engaging courier were an almost inseparable trio,⁷¹ and Agazarian instead of keeping as clear of Norman as possible used to meet all of them most evenings over cards. The courier was the only British-trained member of this group who had had any resistance experience; and her experience told, unhappily, in a dangerous direction. In the PAT escape line she had belonged to a splendid and daring fellowship of resisters, who would have scorned to steer clear of their personal friends lest seeing them should endanger the circuit; much of their work had been against Pétain's police, not Hitler's; and she had long left France when the PAT leaders' friendliness with each other enabled Hitler's police to demolish the line.⁷² The real wonder is not that Suttill and his friends were caught, but that it took so long for so many Germans to catch them.

We have Placke's word, for what it is worth, that Déricourt was not directly concerned in the PROSPER disaster;⁷³ this stemmed from a different and simpler cause: the carelessness of the leaders. Undoubtedly by midsummer 1943 the enemy security services were engaged in an all-out drive against F's operations in general and this circuit in particular; in the end as often happened they caught up with it partly by accident and partly by design. Undoubtedly, also, their design was helped by the obscure yet important incident of the air mail; much of the agents' correspondence with London was watched by the Gestapo, with Déricourt's assistance.

One of the most rash things the agents did was to send long-reports home by Déricourt's aircraft, either inadequately coded or altogether *en clair*. Again, it is intelligible that it did not cross their minds that somebody among them might be acting on the opposite side. In a normal fighting unit, in that war, such conduct was unthinkable; but F section was not a normal fighting unit, and work behind the lines has its own rules, of which universal scepticism is the first. *Dubito, ergo sum* – I doubt, therefore I survive – must be the motto of every successful secret agent; it was the motto of all F section's best men, Brooks, Cammaerts, Cowburn, Heslop, Rée, George Starr. In Suttill's circuit people did not doubt enough, until the crash; and then some of them doubted too much, so that the rot spread farther than it need have done.

It is clear that some F section mail passed through German hands as well as Déricourt's. Frager for instance reported that *Colonel Henri* had told him that the Gestapo knew what was in DONKEYMAN'S July 1943 mail to London;⁷⁴ several captured PROSPER agents were shown photostats of their circuit's correspondence.⁷⁵ Déricourt's own reports, a few of which survive, were not coded at all, except that agents were described by their field names; that they were ever seen by the Gestapo may be inferred by his detractors,

but not proved. Kieffer of the SS deposed in 1947 that ‘material which Boemelburg had had photographed by his agent *Gilbert/Déricourt*, and which was kept in my safe ... was ... put to very good use during the interrogation of *Prosper*’;⁷⁶ whatever the origins of this material, there is no doubt the Germans had it. As SOE’s security staff observed on 1 November 1943, ‘The constant tapping of courier yields the Gestapo in the long run a far higher dividend than the arrest of a few agents engaged in sabotage, or even the break-up of a whole organization which we can re-start with entirely different personnel unknown to the Gestapo’.⁷⁷ Buckmaster retorted that ‘I cannot agree. ... The courier which might have been seen by the enemy is of very little practical value’;⁷⁸ an unexpected remark in the light of reports he had seen and marked himself, such as Antelme’s of 21 June 1943 which any intelligent reader could get the drift of before ever he attempted to crack the coding. Goetz had no trouble in understanding its account of Antelme’s conversations with Herriot,⁷⁹ and from a number of such reports a very fair picture of agents’ modes of life could be, and was, built up. Worse, agents’ addresses and the areas they were interested in exploiting could be deduced from these papers as well. The Germans thus secured a substantial body of intelligence about F’s operations round Paris and in the Loire and Gironde valleys. They noted it down and bided their time; and Bleicher and Vogt maintained, after the war, that it was ‘through the mail’ that the main arrests had come about, Bleicher claiming that the Germans saw nearly all the PROSPER mail, and Vogt specifying that it revealed addresses.⁸⁰ They may of course have exaggerated its importance in order to safeguard a German agent; but the point about addresses at least was true. Culioli was shown by Goetz, while under interrogation soon after his arrest, not only a note of his own address which the Germans had already extracted from a captured colleague, but addresses which he knew to be correct of Antelme and Lise de Baissac – both of them then free – which his colleague did not know; for these the BRICKLAYER and SCIENTIST air mail was the probable source.⁸¹

A crisis in PROSPER’S affairs was nearly precipitated in May 1943 by an unforeseen intervention from outside. By a striking coup known as NORDPOL (NORTH POLE), the Abwehr staff in Holland had managed over a year before to secure almost complete control of the SOE circuits supposed by London to be operating in Dutch territory.⁸² London repeatedly requested that an agent come back by DF channels to report, and provided an address in Brussels through which contact could be made with an escape line. (The Brussels address was also, unknown to London, under German management.) In the end, having run out of excuses, the Abwehr team running NORTH POLE fed two of their men on to this line, and they got to Paris in mid-May.

The leader, ostensibly the guide, of this pair was Richard Christmann (*Arnaud*); his assistant, purporting to be the travelling agent, was Karl Boden (*Adrian*). Christmann, born near Metz in 1905 and deported to Germany with his quarrelsome family in 1919, had been a French foreign legionary and

a Gestapo spy; by this time he had settled down – comparatively speaking – as a subaltern helping Giskes to organize counter-intelligence in Holland. He remained as always highly strung; and a hostile interrogator later noted that he ‘looks and behaves like a waiter’.⁸³ His bogus escape line was not a very good one, as when he got to Paris his only instruction was to ‘ask *Hélène* for *Gilbert*’. He asked an Abwehr contact, Delfanne’s, or possibly Placke’s, mistress; who referred him to the proprietor of the Bar Lorraine, in the Place des Ternes; who glanced at his watch and said ‘Oh, you’ll find him playing poker in the Square Clignancourt’. In a café there, near the Sacré Coeur, the two ‘Dutchmen’ found Gilbert Norman, deep in a poker game with the Agazarians, Andrée Borrel, and a young French couple who belonged to PROSPER; and introduced themselves effortlessly as Dutch agents in search of a route to England. No one made any fuss about passwords.⁸⁴

They had of course met the wrong *Gilbert*, but Agazarian who was acting as Déricourt’s wireless operator and knew the current Lysander programme took it on himself to arrange details. What followed can best be given in his own words:

As [I] decided it was impossible to do the operation before June, [I] agreed to *Adrian*’s suggestion that he should return with *Arnaud* to Brussels, which they did on the evening of May 20th, having fixed a rendezvous for the Capucines for 10 o’clock on June 9th. Between May 20th and June 9th [I] had no contact with *Adrian* or *Arnaud*, and no one knew of the rendezvous except the son of the friends at the safe house.

[We] met at the Capucines as arranged, *Adrian* and *Arnaud* being already there when [I] arrived. Only about five tables were in use inside the café, the rest of the café being roped off for cleaning, and at one of the tables on the terrasse outside the café was a civilian in a grey hat and a mackintosh, with nothing on the table in front of him. *Arnaud* afterwards said he did not think this man was there when they arrived: up to about a minute before [I] arrived, the café was empty, and then suddenly it was full of people.

[We] had been there a little time and [I] was in conversation with *Arnaud*, when [I] noticed *Arnaud* looking over his shoulder at two German officers dressed in green uniform (they might have been Feld Gendarmerie) questioning other people. Immediately *Adrian* got up and with his hands in his pockets, walked out: not fast enough to be in a hurry and not slow enough to be quite natural. The German officer looked up, watched *Adrian* go out and went on with the examination. *Arnaud*, who saw *Adrian* being taken across the road by a civilian, said to [me] ‘They have arrested *Adrian*’; [I] told him to be quiet, and [we] proceeded to discuss [our] cover story. The German officer then asked for [our] papers, which he examined thoroughly, but took no further action. [I] and *Arnaud* left the café separately and [I] joined *Monique* and *Delphin* at the Napolitain.⁸⁵

Christmann (*Arnaud*)'s *bona fides* was thus established, in the whole PROSPER connexion's eyes; but Christmann himself, satisfied with having broken into the centre of an important network, withdrew to report what he had found. *Adrian*'s 'arrest' left a vacant place on the now imminent June Lysander; and Suttill insisted that it be filled by Agazarian, with whom – unlike the rest of his colleagues, who liked him – he did not get on. He suspected the younger man – Jack Agazarian was rising twenty-eight, Francois Suttill was five years older – of being too careless to be let loose on the organizing work of his own that the wireless operator was anxious to begin.⁸⁶ Mme Agazarian had to leave in any case, as she had not Andrée Borrel's remarkable physical toughness and could not take the full strain of courier work in the inflated PROSPER area. As we saw a few pages back, the Agazarians caught the aircraft that brought Diana Rowden and Noor Inayat Khan to France on 16/17 June. They were just in time – this time.

By now, as de Baissac put it in August, 'Many arrests are made every day in France as nearly everyone is now engaged in some subversive operation or other.'⁸⁷ Hardly a week had passed since March without the disappearance of some connexion of Suttill's inflated range of contacts, that reached by now from Nantes on the Atlantic tidal stream, through the middle Loire and Paris, to the Belgian border round Sedan.⁸⁸ Sometimes these arrests were important: E. M. Wilkinson (*Alexandre*) for example was picked up by the Germans in Paris on 6 June,⁸⁹ in a police trap Suttill and Antelme had vainly begged him not to enter; and with him the usefulness of the PRIVET circuit round Angers, where he was well known, disappeared. He gave nothing away; Buckmaster called him 'as hard as they come'.⁹⁰ But real trouble blew up in the second half of June.⁹¹

On the night of the 15/16th a pair of young Canadians, Pickersgill (*Bertrand*) and Macalister (*Valentin*), were successfully parachuted to Culioli's sub-circuit in the Cher valley north of Valençay.⁹² Their mission was to set up another sub-circuit, ARCHDEACON, on PROSPER'S eastern marches round Sedan. They stayed a few days with Culioli and Yvonne Rudellat near Romorantin, while Pickersgill's papers were improved and Culioli was busy receiving stores and men; Macalister's accent seemed beyond repair to his hosts. F section had provided him with an excellent cover story to account for it, which he never had a chance to deploy. On the 21st all four of them set off by car for Beaugency on the Loire, where they were to take the train for Paris. To their surprise, they found the village of Dhuizon in the Sologne full of troops, and were stopped at a control; the Canadians were held for questioning, and Culioli and Mme Rudellat who tried to break away were pursued, fired on, wounded, and captured a few miles away.⁹³

Three nights later, *propter hoc* rather than *post hoc*., the Germans made some still more important arrests, and decapitated the PROSPER circuit. The Canadians had brought with them several work messages for other agents, which the staff had been trusting enough to send in English and in clear,

addressed to each agent by his field name; particularly, some new crystals and detailed instructions for their use for Gilbert Norman. Culioli had done all these up in a brown paper parcel addressed to a fictitious prisoner of war in Germany. The parcel was found in the car locker, and opened in hope of loot; the contents turned out important. The Gestapo had long watched PROSPER, and decided to close in on such addresses as they knew.⁹⁴

Suttill himself had by now become worried about his overblown circuit's security. He was blithely conducting a negotiation with some subordinate German policemen for the release of the two Tambour sisters, arrested back in April, in return for a million francs; he in fact handed over through Worms one half of a pile of notes worth that sum, torn in two down the middle, as an earnest that the money did exist; and sent Worms, bearing the other half, to a rendezvous near Vincennes prison. The Germans, thinking it a huge joke, produced a couple of elderly whores, and demanded another half million before they would release the Tambours. This perilous negotiation was still in train late in June.⁹⁵ What disturbed Suttill more was the question of letter-boxes. He discovered that Noor Inayat Khan had been sent to France with a dangerous address he had cancelled the previous February, and confirmed as cancelled when in London in May; and that Lejeune had been broadcasting the same address round several friends. This, he pointed out, was intolerable; and he cancelled all his current letter-boxes and passwords from the date of his last report to London, 19 June.⁹⁶ He never had the chance to circulate new ones.

Norman and Andrée Borrel dined on the 23rd at the Guernes' flat in Montparnasse, and left towards eleven o'clock, he by bicycle, she by métro. He had lately left her sister's flat in the suburbs, and was staying again with the Laurents (he and Laurent had known each other since childhood) near the Pompe métro on the corner of the Boulevard Lannes and the Avenue Henri-Martin; an address to which he had presumably been shadowed by the Germans.⁹⁷ She went there also, and settled down to help with some coding. Not long past midnight, there was a knock on the front door, and a voice cried 'Ouvrez, police allemande'. Maud Laurent, who thought some friends were pulling her leg, went to the door; she found herself looking at the wrong end of several revolvers, and the whole household were taken prisoner at once.

Suttill was out of Paris that night, having business at Trie-Château by Gisors with George Darling, his east Normandy sub-organizer. By three in the morning German police were waiting for him in his little hotel room in the rue de Mazagan in the working-class district near the Porte St Denis, and he was arrested there between nine and ten o'clock next morning. It is suspicious that the Germans found out his address so fast; he had lately moved, and it should have been known only to Andrée Borrel and Gilbert Norman.⁹⁸ Several Germans have testified that she never talked at all – she treated them with fearless contempt throughout – and that Norman said

nothing useful to them for two days after his arrest. So presumably one of these two had committed the imprudence of writing Suttill's address down, and it was found when they were searched; or, more likely still, Suttill also had been successfully shadowed.

So far the Germans had done well; and they never knew that if they had played their cards a little more carefully they would have done a great deal better, and might have dealt F section a really hard blow. For Suttill had an appointment at 10.30 on the 24th with Claude de Baissac and at the same hour on the 25th with Antelme, followed by one at 11.30 with Trotobas; to capture four of F's best current organizers in two days would have been a triumph indeed. As it was, de Baissac, finding no one at his rendezvous that Thursday morning, was foolhardy enough to visit Andrée Borrel's flat in the Rue des Petites Ecuries, not far from Suttill's, to inquire what had happened; was intercepted by the concierge, whom the Germans had carelessly left unguarded, and told by her that they were upstairs; and got away. Antelme also had prior warning; he returned to Paris from Poitiers late that evening, and found Garry and Noor Inayat Khan waiting for him at Garry's Auteuil flat where he lived himself, with the news of Suttill's arrest. (Noor also had been warned by Andrée's concierge of Andrée's arrest; she had heard of Suttill's from the Balachowskys.) Antelme found new rooms for her and moved his own that night, and told Garry to move his; and spent the next three days making contact with Guerne through a series of cut-outs. Trotobas also escaped, by making proper inquiries before turning up at his appointment; so far, the normal security training had answered its purpose, and except for Pickersgill and Macalister contacts outside Suttill's own circuit were safe.

None of the arrested agents at first said anything at all. Yvonne Rudellat was unconscious in hospital at Blois, with a bad head wound. Culioli, with a festering wounded leg, was for the time left alone; Andrée Borrel maintained a silence so disdainful that the Germans did not attempt to break it. They were fiercer in their treatment of Suttill, Norman, and the two Canadians, but all four held firm. Suttill is said by Mme Guépin, the *liquidateur* of his circuit's French affairs, to have been interrogated continuously for three days on end without being allowed to eat, drink, sleep, or even sit,⁹⁹ and this degree of pressure may possibly have had some effect in the long run; though in the short run he kept silent. But someone then cracked; and there is evidence to suggest that the person who cracked was Gilbert Norman. This was against all expectation. His training reports had, mostly been excellent, in spite of some bad slips. In Baker Street his friends continued for some weeks to believe that he was still free, because his wireless was still transmitting,¹⁰⁰ and in the circuit, where his bravery was admired, people trusted him. It soon began to look as if their trust was not well placed.

Two of the weightiest testimonies against Norman deserve to be quoted; he never came back to speak for himself. Kieffer, who was in charge of the

case at Gestapo headquarters, said under oath that *Prosper* [Suttill] did not want to make any statement, but Gilbert Norman, who had not the integrity of *Prosper*, made a very full statement. Through Norman and through the documentary material available we received our first insight into the French section'.¹⁰¹ Goetz revealed when Vera Atkins interrogated him that Norman 'had been quite helpful to them [the SD], especially as regards the moral effect his appearance on apparently good terms with his captors, had on agents captured later';¹⁰² he added that through Norman's 'revelations we got an exact view of the whole organization' of F section in England, about which 'I had hitherto known practically nothing at all'.¹⁰³ On the other hand it is worth remarking that Norman apparently knew of the JUGGLER headquarters in the rue Cambon, near the Place de la Concorde – he is said to have had an appointment there he never kept, at 9 a.m. on the 24th, with Weil and Cohen – and that the Germans never raided it: this was one of the few places they left alone.¹⁰⁴ Moreover he did make one attempt to escape from the Avenue Foch, months after the damage had been done; he was at once wounded and recaptured.¹⁰⁵

For while London was puzzling over what had gone wrong and how far the damage had spread, he was helping the Germans to spread it as far as they could. Here is an example of the sort of thing that happened, taken from an account given by Andrée Borrel's brother-in-law Robert Arend when he eventually got back:

About 9.30 in the evening of July 19th 1943, while Arend was out meeting his wife at the station, *Archambaud* [Norman] turned up at 12 Rue Champchevrier with three Germans in civilian clothes in an open car. *Archambaud* asked Arend's parents to give him the W/T set. This had never been properly hidden, because they had not found a suitable place to hide it, but Arend's father could only find four of the five parts, the fifth being put away somewhere. Arend père therefore went to fetch his son, and told him he thought the Germans had been won over, probably by bribery, and were working for the Allies. Arend returned with his father, to find *Archambaud* and two of the Gestapo in the house, the third Gestapo man remaining in the car.

Archambaud and the Germans wanted to leave immediately but Arend père offered them drinks and cigarettes. He then became more communicative and told them that his son was a refractaire. The Germans thereupon asked for Arend's papers, and took him away to verify them. *Archambaud* left with them.¹⁰⁶

– and Robert Arend was sent to Buchenwald.

And this was happening, not in one Paris suburb but in several; not indeed in one department only but in a dozen. George Darling for example was visited at Trie-Château at the end of June by a party whom he mistook for other sub-agents and guided to one of his numerous arms caches; realising

too late that they were Germans, he opened fire on them and was shot down.¹⁰⁷ The JUGGLER sub-circuit was completely disrupted. Worms proposed to London on the 27th that he should take over the wreck of PROSPER, a step London promptly forbade. He had a meeting with Biéler, Trotobas, Fox, the Guernes, and the Comtesse de la Rochefoucauld on the 30th, to discuss ‘security measures arising from the arrests’;¹⁰⁸ but took none. He continued to eat as he always did at a black market restaurant in the Rue Pergolèse, where he was arrested on 1 July; Guerne was taken with him. Weil, his second-in-command, arriving too late to join the party, saw him being led manacled to a waiting car, and got away to Switzerland at once. This left Cohen (*Justin*) the wireless operator, and Weil’s fiancée Sonia Olschanesky the courier, high and dry. Cohen went to hide in the country. He had forgotten the safe address in Lisbon to which he was to have sent a postcard, asking for DF to rescue him. He confided in a party of workmen whose overheard talk in a café convinced him that they were anti-German; they sent round the hat, thus providing him with money enough to reach Perpignan, whence he made his own arrangements for crossing the Pyrenees, and after some arduous walking got safely back to England in October. Unluckily, a BBC message he had prearranged with his workman rescuers elated them so much that they went back to the café to celebrate, and were arrested and packed off to Germany on forced labour.¹⁰⁹ Sonia Olschanesky survived the rounding-up of all JUGGLER’S contacts in Chalons-sur-Marne that followed two days after Worms’ arrest, and worked in Paris as best she could all autumn; she was caught in the end in January 1944, and went to her death with Andrée Borrel at Natzweiler next July.¹¹⁰

One whole segment of Suttill’s empire remained intact and untroubled: the communist-dominated groups. All but one of these were not so much PROSPER colonies as independent dominions, looking to Suttill for arms and money but not for orders; and their manner of conducting business was their own. They had enough idea of the fundamentals of clandestine work to keep to themselves their leaders’ identities and addresses, and where they kept the arms they got was their secret also. Dealing with Suttill and Norman through couriers and cut-outs, they were less easy prey for the Gestapo than the sub-circuits with organizers trained in England, whose staffs tended to see and know dangerously much of each other. Some of Guerne’s intellectuals also had the intelligence and the security sense to lie low; and one of the British-trained parties was luckier than the rest – for a while.

The leaders of BUTLER, the circuit in the Sarthe which Suttill had been bear-leading, did not feel, or at any rate did not submit to, most PROSPER agents’ liking for good living; Garel was not a left-wing *dévo*t for nothing. He, Rousset, Chartrand, and Fox lay low and got on with their work, collecting arms and occasionally interfering with rail traffic; well enough for Fox to hive off and start PUBLICAN, a fresh circuit round Meaux on the other side

of Paris. But from time to time he returned to see his former colleagues; and he, Garel, and Rousset were all arrested together in Paris on 7 September by no fault of any part of the PROSPER circuit, from the troubles of which BUTLER had been secure enough to remain immune. (Chartrand, who was not with them that week, got away by the VAR line.) They are mentioned here because of the part their wireless set played in the last act of the drama.¹¹¹ Other non-communist sub-circuits in touch with Suttill were less fortunate. SATIRIST for instance was completely broken up, and Octave Simon alone managed to get down to Angers for the August Hudson after three or four hair's-breadth escapes from the Gestapo, who captured the young Comte de Montalembert and all his other colleagues. There is a pathetic account in a life of one of PROSPER'S sub-agents, a country priest with an excellent record from the war of 1914, of how another sub-agent went round the villages near the Chaingy power station, pointed out members of the group to the Gestapo, and betrayed the dumps of arms;¹¹² the villain of this story, Maurice Lequeux, was heavily sentenced after the war, but exculpated himself on appeal by laying the blame elsewhere. And elsewhere it belonged.

For Suttill was offered a bargain by the Germans, after they had battered him insensible and broken one of his arms; weakened by torture, he is said – by an interested party – to have accepted it.¹¹³ Germans captured at the end of the war did not substantiate this; there is no direct evidence that Suttill ever gave his personal consent to the arrangement,¹¹⁴ and plenty of evidence of character to suggest that he did not. For the bargain proposed was that PROSPER'S leaders should order their subordinates to reveal to the enemy all their dumps of parachuted weapons and explosives, in return for a promise that nobody but themselves would be executed. Armel Guerne, who reported the precise terms of the pact, was among the leading group who took their own impending execution for granted. He was not himself much grilled; and claimed to have had the good fortune and the skill to escape from a heavily guarded train on his way to Germany. The circumstances seemed suspicious to his interrogator when he found his way across to London – again, by an obscure channel through Spain – in May 1944. Part of the trouble was that no one in London appreciated that Guerne was a poet, and thought and expressed himself poetically rather than prosaically; worse, his interrogator realised that he was holding something back,¹¹⁵ but did not discover what it was. What Guerne was being reticent about was what he had discovered while a prisoner about the wirelesses the Germans were working back; but as he got so adverse a report from his interrogator, he never got through to the staff of F section, to whom alone he thought something so secret should be reported.¹¹⁶ But we must return to the 'pact' that is supposed to have been made with the Germans. Norman took the lead in circulating news of it, though he always claimed to have had his commander's agreement. The number of arrests made as a result ran into

several hundred figures as high as 1,500 are sometimes quoted, and 400 would be a conservative estimate. No one need be surprised that intense indignation and resentment has been felt about these arrests by the thousands of French families concerned in, or closely aware of, them; or that they did nothing to serve the cause of the *entente cordiale*.

What explanation of the disaster can be given? It is not easy to get into the minds of men who decided to make such a concession.¹¹⁷ What had these hundreds of resisters been there for, but to collect arms and hide them, learn how to handle them, and in the end use them? What did every lesson ever taught at Beaulieu lay down as the duty of the sub-agents of a penetrated circuit? Flight. And of a captured agent? Silence.

It is a mark of the degree of strain that clandestinity imposes on responsible leaders that any of them should ever have agreed to anything so inane as the pact. They had fought the Germans long enough to know their enemies' word was worthless: as the later deaths of many of PROSPER's followers, in every circumstance of terror and degradation, proved it to be. Someone's resolution must have been annealed not only by torture but by some particularly dexterous interrogation, in which Vogt's suavity no doubt combined with Goetz's intelligence. Much use was made, against all the London-trained agents captured about this time, of a detailed and accurate description of some SOE training arrangements and part of the main head-quarter staffs. The bulk of this information had presumably come from outside France, through the unhappy captives of NORTH POLE. In Holland great successes had been scored by false hints to the captives that there was a traitor highly placed in Baker Street; the same trick was used in France, with satisfactory results from the enemy's point of view, and this legendary tale is now, to England's harm, ensconced in the minds of many survivors. Probably, indeed, the influence of this double depressant – the thought that someone who had sent him on his journey had in fact been engaged on the opposite side, and the impression that in any case the Germans knew all the answers – sapped Norman's resolution. He may even have thought it best to inform the Germans of many details of a circuit they had penetrated, so that London would replace it with one they had not. Both he and Suttill were kept apart from the untameable Andrée Borrel. Suttill undoubtedly was the responsible commander of PROSPER, and without his consent Norman should not have busied himself as he did in carrying through to the hilt the bargain about surrendering the arms; but it was certainly Norman and not Suttill who conducted most of the negotiations with the sub-agents, as Suttill was shortly taken away to Berlin for unproductive further grillings at Himmler's headquarters.

To sum up, Suttill and Norman were no longer, at the time of their arrest, in a mood in which they could trust themselves to make calm and considered judgements; prolonged clandestinity had taken its toll, and dexterous handling by the enemy overwhelmed them, or overwhelmed Norman at least. Physical

knocking about left them resolute, as it left the Canadians; what they found unendurable was the psychological counter-mining to which Goetz subjected them. Someone therefore gave away infinitely more than was prudent; but no one should condemn him for doing so who does not know he could have done better, under a similar strain, himself.

A few of the very best of Buckmaster's agents did much better when they were caught in similar traps. Whoever the turncoat in PROSPER was, his conduct contrasted sharply with that of Jack Agazarian, whom we saw removed from danger a few pages back by a June Lysander. On his second mission Agazarian's luck ran out.

F section was promptly informed of the first wave of PROSPER arrests; by Noor Inayat Khan, who had been taking lessons in clandestine transmission from Gilbert Norman up to a day or two before; by Grover-Williams's operator Dowlen who took over transmission for Déricourt; by Dubois; by Barrett and Cowburn, who had heard from Octave Simon; and by Worms' operator Cohen who had only arrived (to a PROSPER reception) ten days before the troubles. Clearly a sizeable catastrophe had occurred, and Bodington persuaded Buckmaster to let him go across to France himself on a brief reconnaissance to find out what was up.¹¹⁸ The mission was mounted in a hurry; no newly trained wireless operator happened to be available, and Agazarian was recalled from leave to spend a few more weeks in the field. The pair crossed to France, by FARRIER's first Hudson operation, on 22/23 July, and reached Paris without incident; Déricourt put Bodington into the Besnard's flat in the place des Ternes, within half a mile of his own, and Agazarian stayed in a humbler house near by.

Bodington was for some days at a loss; though not at such a loss as the Germans liked to pretend. Goetz's interpreter Vogt, as anxious as his master to claim that he knew everything and everybody, told a captured agent in November that 'as a matter of fact, I dined with Bodington here in Paris no longer ago than last night', three months after Bodington had left France; a useless lie, as that agent was impermeable to tricks.¹¹⁹ All the available addresses for making contact with anyone in PROSPER were presumably unsound by late July, nor had Déricourt any suggestions to offer. But Norman's wireless was still working to London; and F section, uncertain whether he was free or not, asked for a contact address and passed it on through Agazarian to Bodington. Neither man thought it at all likely that the address was safe; but they thought they ought to investigate. In the end, instead of devising some cover excuse a third person could use to reconnoitre, they tossed for which of them should go himself.¹²⁰ Agazarian lost; not best pleased, he called at the suspect apartment on 30 July and was at once arrested.

His captors identified him at sight; they knew quite as much about him as they had known about his companions in PROSPER, and knew that he had plenty he could tell them; but he refused to talk, in spite of brutal torture promptly and long applied.¹²¹ Telling him he might as well save himself pain

and come across with the few fragments he had that the enemy needed to complete their jig-saw of information was waste of breath; nor was he shifted by legends of a traitor in high places at home. He maintained this stubborn silence to the end; which came before a firing squad at Flossenbürg, six weeks from the end of the war. One of the most striking ironies in the history of F section's work is this: that many decorations have been conferred on less deserving colleagues, and much ink has been expended in efforts to make some of the least worthy of them appear as heroes; while Agazarian's truly heroic conduct has remained all but unnoticed.

Bodington meanwhile was left looking for a wireless operator. He tried to get in touch with Dowlen; but Dowlen was caught by direction-finders,¹²² the day after Agazarian. An attempt to use Dubois was equally unsuccessful, as his family were arrested and deported to Germany early in August and he was in no position to work for anyone else for the moment. Cohen was also unavailable; this only left Noor Inayat Khan. Through her Bodington discovered two apparently intact fragments of PROSPER: Garry's CINEMA subsection, of which more shortly, for which she worked as wireless operator, and Marc O'Neil's OCM group lately transferred from SCIENTIST, to which it returned. There was apparently nothing else Bodington could do in Paris, save help her to move house yet again and provide FARRIER with some money for the famous bar in the rue St André des Arts; his own security preserved by the Germans' calculations, he returned to London on Déricourt's next aircraft (15/16 August).

The case of CHESTNUT is not so exactly in point, because none of its arrested members had been, as Agazarian had, direct participants in PROSPER's work. But its leaders knew Suttill and often met him; its main working area, just south-west of Paris, overlapped with Suttill's domains; we have already noticed its use of a PROSPER wireless channel and of Déricourt's aircraft, and its leader's wife was mothering Noor Inayat Khan. Besides, the circuit was snuffed out only a few weeks after PROSPER, by the same team if not by the same methods, and most of the prisoners shared the same fate: indeed Grover-Williams and Suttill passed the last year of their lives in solitary confinement in adjacent cells at Sachsenhausen.¹²³

CHESTNUT'S downfall was abrupt. It was left quite unscathed by the neighbouring catastrophes of June and early July; though dangerously close to them – its two principal figures, for example, accompanied Antelme from Paris to Tours during his final escape.¹²⁴ The circuit remained very small, consisting really of three racing drivers – Grover-Williams, Robert Benoist, and J.-P. Wimille – who used their wives and one or two women friends as couriers, and cached their arms dumps on the Benoist family estates round Dourdan, in the Orge valley south-east of Rambouillet, within twenty-five miles of the centre of Paris. Dowlen their wireless operator, a self-contained scoutmaster, lived out of the way at Pontoise. But there a direction-finding team caught him at his set (31 July); and thirty-six hours later the Germans

arrested Robert Benoist's brother Maurice at his flat in Paris. Maurice Benoist had been on the edge of the circuit and had taken part in one reception, but was not in the leaders' confidence; this he may have resented. Next afternoon (2 August), acting under duress, he accompanied a party of Germans out to the family château at Auffargis, by Dourdan; where they arrested his wife and his father, all the servants, and worst of all Grover-Williams.

Robert Benoist, arrested in the street three days after his brother, made the first sensational get-away of a splendid run of escapes. Four Germans bundled him into a large car, one sitting on each side of him in the back; but they omitted to handcuff him, and also omitted to shut the offside back door properly. When the car swung left sharply off the grands boulevards, Benoist who had tensed himself for this moment flung himself against his neighbour, who had not; they both rolled out into the road. The racing driver scampered off at once into the Passage des Princes, at the northern end of the Rue de Richelieu, and disappeared. He made for a friend's house for a change of clothes, but 'as his friend was obviously very much disturbed by [his] appearance and adventures' left at once for another in the Avenue Hoche; whence he telephoned his chauffeur to meet him in the street outside. His second friend reconnoitred the meeting-place for him, and reported eight strangers waiting about below in belted raincoats; so Benoist left over the roof at the back. He then rang up a garage where he kept a small car and a reserve of petrol stored against this sort of emergency; the Gestapo had collected both the day before. So he hid in his secretary's flat till Déricourt could see him onto an aircraft on 19/20 August.¹²⁵

It is reasonable to presume that after their success with Suttill or Norman the Germans tried the same tactics on the less fortunate Grover-Williams. This time they made no score. The only one of his quite substantial arms dumps they found was in the stables of the château where he was arrested; his subordinates remained untroubled. Without his leadership, it is true, they were ineffective; but at least they were alive, and as free as anyone could be under nazi occupation; they were far better off than the hundreds of captives from PROSPER, and Robert Benoist was eventually able to get a little good work out of them when it was needed most, in mid-June 1944.

Other contrasting cases can be drawn from outside F section; the comparisons are still fair. F section liked to despise RF's agents as insecure, and certainly some RF agents took ludicrous risks at about this time; but once arrested they most of them – like most F ones – managed to stay silent, or to die fast, or at worst only to give away a few acquaintances, and those the least important. There was no avalanche of arrested RF sub-agents like the one in PROSPER, and some of the leading RF figures took much more trouble about security than most of PROSPER's friends.¹²⁶

DF also could play safe. Christmann reappeared in France that autumn, still pretending to be a Dutch agent on the allied side and still using the field name *Arnaud* – phonetically the same as the name he had taken in the

Abwehr, and used at his desk: 'Arno'. N section in London was still anxious to get hold of an agent returned from Holland; four men had apparently started on their journey down the VIC line in midsummer, but never got through, as they were arrested by a road control that for once searched the greengrocer's lorry they were hidden in, between Perpignan and the Pyrenees. Gerson thought they had been sold to the Germans by the lorry-driver, whom he did not re-employ;¹²⁷ in fact, they were four Abwehr agents, whose arrest was pre-arranged.¹²⁸

Christmann himself accompanied the next N section agent to return, who this time was genuine: a young man called van Schelle (*Apollo*) whose aircraft crash-landed east of Antwerp after an attack by a night fighter on its way to Holland in October. Van Schelle went to a contact address in Brussels, whence he was put in touch with a bogus escape line to Paris run as a subsidiary of NORTH POLE. Through channels that appeared genuine to him, he received orders to return at once through Spain; *Arnaud* (Christmann) was to collect and accompany him. This time London provided a contact address in Paris for the VIC line, a quiet house in the Rue Peclet south of the Ecole Militaire run by two maiden ladies called Fradin; and van Schelle and Christmann reached it at the end of the first week of November. VIC took on from there. The pair were moved to a safe house in the Avenue Emile Zola close by, and then taken under a girl courier's charge to Lyons, where they were separated. Van Schelle went on to London, where he arrived in mid-December. Christmann was taken to see Levin, who told him he also was urgently needed there; he had a good deal of difficulty in extricating himself from Levin's hands, on the plea that an important private diamond-smuggling operation required his personal supervision on the Dutch frontier in a few days' time. He was lucky to get away; for Gerson, who was away on a flying visit to Barcelona, received there a message from London telling him to be careful of Christmann whom he himself neither liked nor trusted;¹²⁹ and Christmann's excuse for leaving Lyons hardly explained how he had come to arrive there. Christmann simply vanished from VIC's ken – he went back to The Hague, where for the time being he persuaded Giskes to take no action against the French SOE agents he had met, so that the *Arnaud* cover should remain available for some further adventure in France. However, two months later the blow fell on VIC. On 21 January 1944 both the Ferrys, with whom Christmann had stayed in May near the Gare de L'Est, and the Fradins who had sheltered him in November, were arrested; so was the courier who had seen him down to Lyons; so were the Jacquelots and the Cretins, much-used Paris contact and safe-houses; and so a week later was Mme Levêque, Mme Carnadelle's sister, whose fashionable women's hairdressing shop had long been the central contact house for the VIC circuit in Lyons. Levin himself only escaped because he had left the flat that Christmann had met him in.

Not one of these ten arrested sub-agents provided the Germans with any information of the least use. This demonstrated the wisdom of the principles VIC worked on;

The security measures taken by [him] for the bodies passing down his line are very strict. They change hands as many times as possible, and each courier acts as a cut-out, not knowing where the bodies come from or where they are going. The bodies are kept in a park or other public place until nightfall, when they are taken to the house where they are to sleep. They are not told the address of the house, however, and seldom have any idea where they are, or which courier is in charge of them. Safe houses and contacts are changed every three months, regardless of whether they are blown or not. [He] does not wait for trouble before taking measures to prevent it.

[He] has so arranged his line across the Pyrenees that no one guide can work the whole of the route: each guide knows only his own particular stretch, after which he hands his bodies over to a cut-out (both for the French and Spanish forbidden areas) who presently hands them to another cut-out for the remainder of the journey. The guide does not know where to go until he has received his instructions from the cut-out. Each part of the journey – from Paris to Spain – is divided into sections, and each section is made as nearly as possible into a water-tight compartment. So far [he] has five guides working, and two more in training. They do not come as far as Perpignan, but have the bodies brought to them outside the town by a contact. Guides and bodies are not aware of one another's identities.¹³⁰

Admittedly, this degree of insulation was useless for an operational, rather than an escape, circuit; but if PROSPER had adopted even a quarter of VIC's security precautions the crash would have been less severe, as many sub-circuits could have been saved from foundering alongside their leaders. For the most remarkable feature of the January 1944 arrests was that they left the main VIC organisation untouched. The trickiest part of the line, that lay between Perpignan and Figueras, was unaffected. All that was necessary was to bring into play a new set of safe houses in Paris and a new courier between them and Lyons; VIC had both standing by, and the flow of passengers was hardly affected.

The Germans' attack on PROSPER and F's other circuits in and round Paris brought them a treble dividend. They secured a substantial quantity of parachuted arms; they arrested several hundred troublemakers, and they had in their hands two wireless sets – Norman's and the Canadian Macalister's – complete with codes. Professionally this was the most interesting dividend of the three for the *Sicherheitsdienst*. Goetz their chief wireless man happened to be away on leave; he was recalled at the end of June, and told to improve on his performance with the *Bishop* set two months earlier.¹³¹ He

did so. During the next ten months the Germans ran four *Funkspiele* ('wireless games') with captured F section transmitters, and were able to exploit a good way beyond their original conquests in the PROSPER circuit, until Baker Street detected what they were up to and they were finally unmasked. Before that happened, they had the double-edged tool of the 'radio game' turned back against themselves.¹³²

Bourne-Paterson, the Scottish accountant who was F's second-in-command, has recorded that the Gestapo 'were encouraged to believe that we were unaware of the extent of their penetration, and deliveries of stores were continued to circuits known to be Gestapo-operated, in order to give time for new circuits to establish themselves'.¹³³ At first glance, it will seem odd that tons of expensive arms and explosives should be delivered, in still more expensive aircraft, by almost irreplaceable aircrew, straight into the enemy's hands. It was in fact a quite sound piece of deceptive activity. And the Germans, deep in a deception scheme of their own which they did not realise the British later counter-mined, did not endanger it by attacking the aircraft. The trouble was that for some weeks the German scheme was more successful than the British realised; and in one unlucky month in the spring of 1944 several agents were dropped, as well as stores, to three different Gestapo-controlled circuits, two of which (PHONO and BUTLER) had been enemy-operated for some five months, while a third (ARCHDEACON), which had been running for nearly three months longer, had never ever worked in the allied interest at all. Most of these agents were young men on their first missions; but they included also the staunch Rabinovitch, one of the section's best and most experienced wireless operators; Lionel Lee, who had distinguished himself in Corsica; and Lee's organizer France Antelme, one of Buckmaster's stoutest men, who went to a Gestapo reception after careful study and at his own request, believing the reception to be genuine. It was certainly never any part of F section's intention to send them straight to their death; nor indeed were their deaths intended by anybody else on the allied side. They were the unfortunates who happened to be caught on an exposed flank while it was exposed.

But how did it come to be exposed, and then to be made safe again? With that question the rest of this chapter will deal.

The whole system of security checks had been devised to meet precisely this case, of an agent captured complete with transmitter and codes. On the occasion of Gilbert Norman's arrest at least it did not work at all. Though the original messages have vanished, there is no reason to doubt the well-known story that when a message from Norman, sent while he was under duress, used only his bluff security check to show home station he was under control, he got a reply drawing his attention to the omission and telling him to be more careful next time.¹³⁴ Goetz said it was this that finally thrust him over the margin of doubt and into practical co-operation with the enemy.¹³⁵ The reply was sent on Buckmaster's orders, although

Norman's arrest had been reported by several different sources a few days before.

Unfortunately the case of Norman did not stand alone. Southgate, who met a number of the victims of this affair in captivity, reported when he came back from Buchenwald that 'Time after time, for different men, London sent back messages saying: "My dear fellow, you only left us a week ago. On your first messages you go and forget to put your true check."' (S/Ldr Southgate would very much like to know what the hell the check was meant for if not for that very special occasion.)' After the operators had been 'put through the worst degrees of torture these Germans managed, sometimes a week later, to get hold of the true check, and then sent a further message to London with the proper check in the telegram, and London saying: "Now you are a good boy, now you have remembered both of them."¹³⁶

In any case, not a great deal of use could be made of Gilbert Norman's set by the Germans, for they did not have available enough of the past history of the circuit; and in such use as they did make of it they sent messages so inept that the deception was detected after a few weeks. Credit for this belongs to Antelme, who remarked naively on reaching London in safety that Norman was 'still free as messages continued to come from him'.¹³⁷ A few days later he told Penelope Torr 'categorically that he is sure [Norman] would have shot himself rather than talk or transmit under duress', and against this remark Buckmaster pencilled 'agree'. Nevertheless, there had been a gap of some days in Norman's transmissions, and when they restarted on 29 June the home wireless station had reported the message as 'unusual, hesitant – quite easily the work of a flustered man doing his first transmission under protest'. Buckmaster and Miss Torr agreed, on their knowledge of Norman, that he was not the type to work under duress;¹³⁸ they showed Antelme the messages, and by 7 August he had convinced them that the texts betrayed enemy control. They evaded important questions from London, such as 'Where is PROSPER?'; they stressed unimportant ones; they said nothing about Déricourt's operations, and nothing at all about Guerne, a close friend of Norman's who had met him almost daily and was in fact of course in prison too. So Goetz's second attempt to work a set back was soon a failure: F section had ceased to believe in Norman's freedom six weeks after his arrest.¹³⁹

Norman did not of course personally work his own set back to London. As usual, Goetz got one of his signals NCOs who had studied Norman's style to imitate it for him, or quite often operated the set himself; though he told Culioli whom he wanted to soften up that Norman had tapped out the Gestapo's messages with his own hands.¹⁴⁰ Nor, in all probability, did Norman co-operate much with the enemy in preparing messages for London; though Goetz later specified that Norman did prepare some drafts.¹⁴¹ But he co-operated in much else. It is also worth notice that for once the Germans had not equipped themselves systematically for a task they had undertaken; the SD, a new party organisation, had not the centuries-long traditions of

Prussian army efficiency behind it, and slipped up. SOE had not yet begun to use one-time-pad ciphers, and the Germans captured Norman's code with him; but had not the time and the staff to decipher many of his previous messages, which they had recorded as a matter of routine in their direction-finding vans.

No such obstacle was in the Germans' way when they came to use Macalister's set, captured complete with its codes at Dhuizon. They had the correct security checks, presumably because Macalister had written them down; and there was no back traffic at all. From one of their prisoners – not necessarily either of the Canadians – they discovered what ARCHDEACON's area was to be; and the SS chief squad leader Joseph Placke, a salesman turned policeman in 1939, set out to exploit it. This he did with such success that Buckmaster published in 1958 a map of F's circuits in France in which a wide area in northern Lorraine and Alsace was boldly marked with the name of ARCHDEACON's leader Pickersgill.¹⁴² He forgot that Pickersgill was arrested a few days after reaching France.¹⁴³ Fifteen large drops of stores were made to this bogus circuit during the ten months that London believed it to be flourishing. A sabotage instructor, Francois Michel (*Dispenser*), sent to it three months after its leaders left England, vanished; his route was roundabout, via an RF pickup operation in Burgundy and a contact house in Paris notified by Macalister's wireless. Not till the war was over and he was dead did London understand how he had gone astray. Yet as one of F section's officers put it long afterwards, 'We had reason to believe in that circuit as an existing circuit because it did in fact exist'.¹⁴⁴ Placke, who spoke good French and a little English, toured the ARCHDEACON area and impersonated Pickersgill; he formed a number of reception committees of genuine French resisters who did not know that the lorries he obligingly provided to remove the stores dropped to ARCHDEACON were in fact driven by Germans in plain clothes. (The stores were all kept in the Satory barracks near Versailles, where in the end almost all of them were recovered by the allies intact.¹⁴⁵) Placke imposed himself in Paris also, on at least one genuine F section agent who happened not to have met Pickersgill.¹⁴⁶

For some time F section was completely taken in by this radio game; so taken in that at the beginning of March 1944 not only stores but six agents were dropped to ARCHDEACON receptions and, of course, at once arrested. Three of them formed a mission called LIONTAMER, which was to have become a circuit round Valenciennes: Lepage, in command, with his fellow American Lesout and Finlayson a British W/T operator. A young pilot officer, Macbain, on his way to join MUSICIAN dropped with them and shared their fate. On the same night, though to a different ground, the fiery Rabinovitch, starting BARGEE at last a circuit of his own near Nancy, dropped with a Canadian, Sabourin, who was to help Defendini the Corsican organizer of PRIEST, a new circuit to be set up round Verdun.

Defendini had left a few days earlier by the VAR sea line, crossing into France the same night as Frager; and went straight as ordered to a contact house in Paris to find out where he was to help receive Sabourin. But the contact house had been supplied by ARCHDEACON, and the Germans were waiting for him there. A brief excursus is needed on his fate: unlike his companions in misfortune, he was able three months later to get word out of gaol. He smuggled half a dozen written messages for Frager out of the Gestapo prison at 3 bis Place des Etats-Unis,¹⁴⁷ with the help of a Russian sentry. They were put in the form of impassioned letters to a mistress – the Gestapo being cast in the role of an over-jealous wife, who made it impossible for the writer to meet his beloved for the moment – and on the inside pages, in a Playfair code built on the title of the only film Frager and Defendini had seen together in England, the Corsican gave valuable news about other captured agents and what he had and had not admitted in his own interrogations, and sketched a really ingenious plan to secure his own escape if it was impossible to send in, by his extempore courier, the bar-cutting tools he asked for. His morale was evidently splendid, and he had begun on a tunnel; but he was soon moved away, through Fresnes, to Buchenwald.¹⁴⁸

Sabourin and Rabinovitch arrived punctually at their dropping zone on 2/3 March, and got clear of their flying kit before the reception committee came up to them. The field was on the edge of a wood; and, hearing German spoken, they slipped into the trees and opened fire on the speakers. In the moonlit gunfight that followed two Germans were killed, but both the parachutists were wounded and made prisoner.¹⁴⁹ Neither was of any use to the Germans.

As neither Sabourin nor Finlayson ever came up on the air with the messages that Morel had arranged with them verbally before they left, to indicate that they were safe, he became suspicious at last of ARCHDEACON; and sent a message that an officer would go to this dangerous area in May to talk to the circuit by S-phone. Pickersgill, brought back from Ravitsch to take part in this conversation, had other ideas: he set about his guards in the Avenue Foch with a broken bottle-end, killed two of them, leaped from a second-floor window and ran off, only to be brought down by the sub-machine-gun of an alert sentry and returned to a concentration camp for eventual execution, with Macalister, next September.¹⁵⁰ John Starr was taken out to the field instead, and at the last minute refused to work the S-phone in Pickersgill's place. This was a useful if belated service to SOE, as von Kapri's voice was recognised from the air by Morel as unmistakably German, and drops to ARCHDEACON ceased; though wireless traffic went on for some weeks more, to keep the Germans guessing.¹⁵¹

But what was John Starr doing in this company at all? He last figured in the text in Dijon prison, where the Gestapo occasionally used his wound to torture him.¹⁵² Late in September 1943 he reached 84 Avenue Foch, and Ernest Vogt went to work on him; assisted by Gilbert Norman, who – Starr

said – told him ‘that the Germans knew all, and it was no use to hide anything.’¹⁵³ Starr filled in on a map the rough area his circuit covered; and the Germans were struck by his penmanship. They wanted to keep a tame or half-tame agent in the building, to shatter the morale of incoming captives; whatever Norman’s usefulness to them had been, it was by now nearly exhausted; so they sent Norman away, to Fresnes and eventual execution, and kept on John Starr instead.

Starr had had more than enough starvation and brutality in Dijon; Fresnes had been crowded. In the Avenue Foch he had decent food, adequate tobacco, and a room to himself. He had probably never come across Housman’s melancholy lines:

There in their graves my comrades are,
 In my grave I am not.
 I too was taught the trade of man
 And spelt the lesson plain;
 But they, when I forgot and ran,
 Remembered and remain.

Also he disliked discomfort: ‘it was as much his desire, as that of the Germans, [that] enabled him to stay on’.¹⁵⁴ He took a liberal – from the official viewpoint, a far too liberal – interpretation of the advice he had been given at Beaulieu: that if he fell into enemy hands, it would be as well to play along a bit with his captors, to save himself from torture. For several months, he made himself thoroughly agreeable at the Avenue Foch. He kept his hand in as a commercial artist by sketching portraits of the staff; worse, according to Goetz, ‘The English text of the [played-backed] messages was checked on every occasion by Herr STAR.’¹⁵⁵ No wonder the official world looked coldly on him; and no wonder he spent the rest of his life outside the jurisdiction of the crown.

He told himself that it was his duty to find out how much the Germans knew about F section’s work, so that he could escape later and report this home;¹⁵⁶ and he did in fact, one night late in 1943, make an ingenious escape from the Avenue Foch, with Noor Inayat Khan and the French colonel, Faye, a former head of ALLIANCE. They all undid the bars of the skylights over their cells, with a screwdriver abstracted by Starr while mending a vacuum-cleaner for the Germans, and got out onto the roof; but they were soon recaptured in an adjoining house during an air raid.¹⁵⁷ Starr thereafter gave his parole that he would not escape:¹⁵⁸ the other two did not. This can be picked on as the moment when his usefulness to the allied effort came practically to a standstill. Had he had better luck with his escape and got away, got on to a DF line and returned to England, he would undoubtedly have had a hero’s welcome; his achievement would have been remarkable, and the intelligence he brought back important. But once he gave his parole,

he gave in; and his refusal to work the S-phone for ARCHDEACON was his only remaining service to SOE. He continued to live easily – for a time; now telling himself no doubt that he might yet get a chance to pass on what he knew to someone not on parole, and that anyhow he was gleaning useful intelligence. He seems to have been too confident of his own cleverness to consider what effect his presence in ease and comfort in that place was bound to have on his colleagues in SOE who also fell into Gestapo hands.

Goetz and Placke, the Germans who benefited most from his work, described him as weak and misguided rather than knowingly treacherous; that was why he was never prosecuted, as several of his fellow agents had demanded.¹⁵⁹ Placke said straight out that John Starr ‘was entirely agreeable to working for us’,¹⁶⁰ and Goetz added that ‘I employed him several times over. It was he who corrected various spelling and editing mistakes for me, and showed me the proper way to draw up a technical message.’¹⁶¹ (Starr admitted this was so, though protesting he was not Goetz’s paid agent.)¹⁶² Goetz’s opinion fitted in with Starr’s British interrogator’s impression,¹⁶³ but did not add up to that ardent desire to assist the enemy which a British prosecution has to prove in a case of high treason. Starr in fact was clever; Goetz was cleverer.

Unluckily for F section, Goetz was not only cleverer than Starr, but cleverer than F. Another remarkable instance of this, in the same field, occurred at about the same time; the Germans behaving with proverbial if rather superficial tenacity, the British with an unwarranted optimism.

Garel the BUTLER organizer had been detained in Paris by a broken ankle; and there he, Rousset his Mauritian wireless operator, Fox his recent subordinate, and a courier were all caught at lunch at a friend’s flat. (The Germans had found them there by routine police inquiries of a BUTLER sub-agent captured as far away as Nantes; who gave away one at Sablé-sur-Sarthe, a considerable BUTLER centre; who in turn gave away a Paris contact house; of which the tapped telephone led them to the flat.) Rousset began by denying his identity; but was correctly described to the Germans as *Leopold* the wireless operator by Gilbert Norman and then, with more hesitation, by Dowlen, both of whom had trained with him; and, after torture, by the courier. After two days Rousset admitted who he was, but continued to make difficulties for his captors; priming them with details to put into his messages which he reckoned London would certainly spot as errors, misdescribing his security checks, and telling them that he transmitted in French for Biéler and Fox and in English for Garel. In fact the reverse was true.¹⁶⁴

The Germans believed him, and sent a message to London in English in Rousset’s captured code that purported to come from Garel. London’s only reaction was to inquire why Garel had changed language.¹⁶⁵ BUTLER was operated by the Germans, much to their profit, for nine months after Rousset’s arrest; and as well as numerous containers they received, on 29 February

1944, DELEGATE – the Belgian Detal and the twenty-year-old Duclos – as supplements for the long extinct BUTLER team. Their role, had they stayed free, would have been to disrupt communications between Brittany and the rest of France; and twelve stores drops were sent to help them carry it out. Another and a more experienced pair of officers, Octave Simon and his wireless operator Defence (*Dédé*), went down to another BUTLER mis-reception a week later, on 7 March; they had hoped to set SATIRIST up on its legs again round Beauvais.

They, like the LIONTAMER team, went straight into prison and stayed there; but not all the prisoners captured in this series of German successes remained permanently in German hands. Rousset was sent, with most of these captives, to Ravitsch, whence he was brought back to Paris in May 1944 in the vain hope that he would help the Germans answer some awkward questions from London. He was kept in the prison in the Place des Etats-Unis, where he took his turn with the rest at sweeping the corridors under a sentry's eye. One day early in June he noticed no one else was about, knocked out the sentry, ran into the garden, and got away over the wall and through a convent next door. He borrowed a telephone to ring up a woman friend, who brought him clothes and papers, and lay hidden in Paris till its liberation, in which he fought hard and well. This sort of aggressive turning of the tables on his captors was what every agent was trained to develop; few were able to put it into practice after so long in enemy hands, and for many the shock of capture numbed the desire to escape.

There was a fourth 'radio game' in progress in the winter of 1943/44 which was more important even than the BUTLER game; the circuit that it took over was Henri Garry's CINEMA, and to understand it we must cast back a little in time. Garry had originally joined SOE as a courier for Philippe de Vomécourt; he was never in England for training. He was brave and competent; Antelme came across him, and handed him on to Suttill, who put him in charge of the Eure-et-Loir, and named him *Cinema* because he bore a slight resemblance in face and build as well as name to Gary Cooper (when London heard of this they changed the circuit name to PHONO). Garry was to prepare attacks on railway and telephone targets in the triangle Chartres-Etampes-Orleans.¹⁶⁶ He spent a good deal of time in the west end of Paris, where he was courting Mlle Nadaud whom he married on 29 June – five days after Suttill's arrest. Antelme who had been staying with him till a few days before kept clear of the ceremony; but Garry's newly arrived wireless operator attended.¹⁶⁷ This was the fascinating Indian princess, Noor Inayat Khan (*Madeleine*),¹⁶⁸ a direct descendant of Tipu Sultan, the daughter of a Sufi mystic, born in the Kremlin on new year's day 1914 to a cousin of Mary Baker Eddy's. She had spent much of her life in France – she used to write children's stories for Radio Paris – and was almost bilingual in French and English, though she spoke each with a trace of foreign accent. Her appearance, noticeably un-French, was as striking as her character, which

was strong and flexible as a rapier-blade; she radiated grace. She had escaped from France with her mother and a brother in 1940, and had been working as a corporal wireless operator in the WAAF before she was transferred to SOE in February 1943.¹⁶⁹

Colonel Spooner, once head of the Beaulieu group of schools, is reported to have said that ‘he had made adverse reports (in the technical sense) on both *Madeleine* and Odette [Sansom] ... because he had considered them too emotional and impulsive to be suitable for employment as secret agents [Mrs Sansom’s finishing report, it should be interjected, does not bear out the reference to her] ... he had really stuck his neck out and gone to considerable lengths in his endeavours to prevent *Madeleine* from being sent to France as an agent. Not only was she too sensitive and easily hurt, but her inexperience, in his opinion, rendered her too vulnerable from a security point of view.’¹⁷⁰ A fellow agent who trained with her put it still more directly: ‘a splendid vague dreamy creature, far too conspicuous – twice seen, never forgotten – and she had *no* sense of security; she should never have been sent to France’.¹⁷¹ It happens that her finishing report from the Group B schools survives in her personal file: ‘Not overburdened with brains but has worked hard and shown keenness, apart from some dislike of the security side of the course. She has an unstable and temperamental personality and it is very doubtful whether she is really suited to work in the field.’¹⁷²

Buckmaster entirely disagreed – for instance, he jotted ‘Nonsense’ against the comment on her personality.¹⁷³ He knew how badly he needed wireless operators, and determined to back his own judgement against the training section’s. This he was fully entitled to try to do; Beaulieu was not infallible. Beaulieu in fact had recommended against the dispatch of Jacqueline Nearne, who was doing exceptionally valuable work for STATIONER, and had doubted the competence of the imperturbable Cammaerts, who was just digging himself in. Spooner appealed to Brook against Buckmaster’s decision to use *Madeleine*; Brook heard them both, and agreed with Buckmaster, without meeting the agent. The event proved that Buckmaster’s inclination had been defensible. Noor Inayat Khan’s brief operational career was exceptionally gallant and was valuable to the section; and when by no fault of her own she fell into German hands she behaved with integrity. The consequences of her arrest, which were grave, were also little fault of hers; and her tragic death can be blamed on the war and the nazi system rather than on the section head who sent her to do her duty.

She was evidently quite lost on arriving by Lysander on 16/17 June: her vivid imagination had not been applied to the actualities of work as a secret agent. A day or two after she had reached Paris, it is said, the Balachowskys, also PROSPER sub-agents, had to remonstrate with her for leaving her code unattended in a briefcase on their hall table, and for ostentatious passing over of a plan in the street; later on she appears to have left her code-book

on the kitchen table of her rooms, where her landlady found it.¹⁷⁴ These were telling instances of the soundness of Spooner's judgement of her before she left England. But she was quite fearless, or rather was quite in control of her fear, and settled down eventually on the northern edge of the Bois de Boulogne in a flat she used for transmissions while surrounded by Germans, one of whom, it is said, once gravely helped her put up her aerial.¹⁷⁵ Her rashness led her to revisit Suresnes where she had spent her girlhood; her prudence, to conceal her exact address even from her oldest friends and her real name from new ones, and to establish a second set of lodgings in the east end suburb of Bondy.

But all this late summer and early autumn she was lying low, on orders from London, transmitted verbally by Bodington. Her original duty, laid down in her operation order,¹⁷⁶ had been simply to act under Garry's command as his wireless operator; but the successive disappearances of Macalister, Norman, Dowlen, Dubois, and Cohen left her as the only F section operator still at large in the neighbourhood of Paris, and she seems in fact to have stayed in and near Paris for almost all the time that she was free, never visiting Le Mans where London had fancied her work would be centred. She emerged from hiding in mid-September to send London a brief summary of the agents who had survived the double downfall of PROSPER and CHESTNUT and were still available for work; and regular wireless touch with her was re-established by the end of the month, when she arranged for a small arms drop. She was under orders to return to England by Lysander; characteristically, she refused this until she could have an assurance about her relief. The arrangements were about to be settled, in the second week of October, when without explanation she went off the air for ten days. When she came up again she had missed her aeroplane, as the moon had waned; and London at first took for granted that she had been captured, as the tone of her messages did not seem quite authentic.

London's suspicions were well founded: the Germans had at last caught up with her.

She had been ardently sought by the Gestapo's right hand, which knew not what its left hand did, as the lead-in to Déricourt's Lysander traffic – this is clear from some of the CHESTNUT womenfolk's interrogations;¹⁷⁷ but no one in that circuit betrayed her. In the end the Germans seem to have captured her by a stroke of luck: someone who knew where she was living and who she was sold her address to them for 100,000 francs (£500 – a price named by the seller – a tenth of what the Germans were prepared to pay for any British officer connected with underground warfare who was denounced to them¹⁷⁸). After the war, her organizer's sister Renée Garry was tried for this offence by a military court, which is said to have ruled by five votes to four that she could not be guilty of it because she had received a testimonial from the British.¹⁷⁹ Whatever private drama was involved, Noor was certainly arrested at the flat she was using on the corner of the rue de

la Faisanderie and the rue Dufrenoy – close to the Avenue Foch – in the second week of October, probably on the 13th. Garry and his wife were arrested there a few days later.¹⁸⁰

With Noor Inayat were captured not only the transmitter she had by her in the flat, but also – from the drawer of her bedside table – a school exercise book in which she had recorded in full, in cipher and in clear, every message she had ever received or sent since reaching France. One of her French associates had earlier protested to her that this was a highly dangerous document; surely old messages should be burnt? She simply replied she had to keep them.¹⁸¹ How on earth did she come to make so elementary a mistake? It must have been through a misunderstanding of her orders. As she was already a fully-trained W/T operator when she joined SOE, she had not been to Thame Park; but she had been through Beaulieu. Her operation instruction did contain a curious phrase: ‘We should like to point out here that you must be extremely careful with the filing of your messages.’¹⁸² Was this simply a staff officer’s howler? It may have been; Agazarian’s orders, six months earlier, included exactly the same words;¹⁸³ so did Clech’s.¹⁸⁴ If not, presumably it referred to the need for messages to be systematically numbered, and arose from a misuse of ‘filing’ in the special sense that it carries for journalists, of feeding a message into the communications system; a sense she might never have heard of. She was certainly too shy, reserved, and conformist a person to think of questioning an order; and, being ‘not over-burdened with brains’, might have managed to misunderstand it as an order to file and keep the messages she sent; worse; as an order that overrode her explicit training instructions to the contrary.

She did not always disregard these instructions; for during her four-day Beaulieu scheme she had done badly under police interrogation at Bristol – she had ‘made several stupid mistakes [and] always volunteered far too much information’¹⁸⁵ – and had been hauled over the coals for indiscretion. This had effect: she behaved much better in the field than Beaulieu would have expected. According to one of them, she caught sight in the street of the first couple of SD men who were sent to arrest her, and simply vanished from their sight;¹⁸⁶ so they had to post a man inside her flat to wait for her return. As a prisoner she was superb; she said nothing to the Germans that was likely to be of any use to them. Kieffer deposed on oath that she ‘behaved most bravely after her arrest and we got absolutely no new information out of her at all. We had already come upon a great deal of material that was useful for her interrogation. She was anxious above all not to betray her security checks.’¹⁸⁷ Straight after her arrest she undertook an attempt at escape, getting out on to the roof from a bathroom on the fifth floor; but was recaptured by the guards when Vogt raised the alarm. She was kept in the Avenue Foch for about two months, and made a second escape attempt with Colonel Faille [Faye] and *Bob* [John Starr. Starr and she] were found about an hour later on the second floor of a neighbouring building. I

decided at once that [she] and Faille should be dispatched to Germany. Both maintained their refusal to give their parole.¹⁸⁸

F section ought to have known she was a prisoner. Marks, when briefing her on her codes, had taken in that she was incapable of telling a lie; he therefore made a special arrangement with her, on top of the routine security checks which she would be bound to confess if asked for them. Between the two of them, they arranged that if in German hands she would send a message with eighteen letters in the key phrase. On first playing back her set in enemy hands, she duly did so. Marks went to Buckmaster with the text, as proof; Buckmaster did not believe him.¹⁸⁹

Untroubled by fetters or loneliness, she maintained her silence about anything that she thought mattered to the end; again the contrast with some of her colleagues is marked. Garry also was silent, till he was shot at Buchenwald in September 1944, at about the same time as she was killed at Dachau; his wife returned a wraith from Ravensbrück.

But meanwhile there were Noor's set, her codes, her security checks, in enemy hands; and all her back messages in clear, from which the Germans were able to study her style of writing. Her style of WT transmission they had carefully studied already: 'we had been D/Fing [her] for months', said Goetz, before she was arrested.¹⁹⁰ So they launched a wireless operation they called DIANA, playing her set back to London by the hand of one of the D/F operators who had often listened to her touch. Their imitations of her were not at first effective enough to carry entire conviction in Baker Street; and for two months London sent to her on the assumption that she was probably in enemy hands. As it drew on to Christmas, under cover of seasonable messages various trick questions were put to her about her family, which London reckoned only she could answer straight; and after some delay, straight answers were received. This is odd; for she was in gaol in Germany by late November, and had certainly resisted all the German attempts to interrogate her – 'she had not helped us in any way' was Goetz's recollection,¹⁹¹ and Kieffer's was quoted just now. But she was naturally a well-mannered and talkative girl; and may easily have chattered away to an apparently sympathetic hearer – Vogt, for instance, who prided himself on having kept her from torture and imagined he had won some degree of her confidence – about family matters which she did not conceive to be of the least military importance. Or a fellow-prisoner may have been set to dig the necessary information out of her in the same way.

In any case, by the end of the year Baker Street was beginning to suspect that she might be free after all. Antelme had seen a certain amount of her in Paris, had been impressed by her character, and took a fatherly interest in how she was getting on; F section staff took him entirely into their confidence, showed him all the telegrams, and asked his opinion. He said that on balance he thought that she was free; and a tentative new start was made with the dropping of arms. Goetz's own impression was that, 'though London

answered our messages, they were not really deceived. At the first reception where we had asked for twelve containers only one container was dropped. This strengthened my view that London had twigged.' But the second drop to CINEMA in the new series encouraged him: the Germans received half a million francs by Mosquito. Whereupon 'I therefore changed my opinion and we [the SD] continued to work the set and to ask for massive receptions. In the early months of 1944, we received not only a great deal of material, but also a number of agents.'¹⁹²

CINEMA-PHONO had never been a lucky circuit, and its luck now ran out altogether. In February 1944 seven agents in all were parachuted to two PHONO receptions which were in fact manned by the Gestapo;¹⁹³ among them the strongest team F section could currently raise, sent specifically to sound out the security of another circuit. Both parties were to have dropped on 7/8 February, the very night of Déricourt's withdrawal to England; but only the less experienced group in fact found their way to their reception committee. Four young men were dropped together near Poitiers: R. E. J. Alexandre, a twenty-two-year-old French aircraft fitter, was to have set up SURVEYOR, a circuit of Antelme's railwaymen friends in the neighbourhood, with the American Byerly as his wireless operator; a Canadian, Deniset, was to be Garry's arms instructor; and the Anglo-French Jacques Ledoux was meant to have started a fresh circuit, ORATOR, round Le Mans. He was a friend of Diana Rowden's and twin brother to Georges Ledoux the RF wireless operator *Tir*.

None of the four got started on their work at all. Byerly's set was soon heard in England; but he sent none of the special messages he had been given verbal orders to transmit if he was not under arrest, and it must be presumed that he was. Antelme nevertheless persisted in his desire to go. Bad weather kept him from trying again that moon; but on the first available night, 28/29 February, he and his two companions left. His wireless operator was Lionel Lee; and the brave, young, and gentle Madeleine Damerment was thought to be the best as well as the least conspicuous of the available couriers. They landed about twenty miles east of Chartres;¹⁹⁴ not much over an hour's drive from the Avenue Foch, whence their reception committee came. A Gestapo officer said afterwards that when Antelme was brought, handcuffed, to his office after a scuffle on the landing ground he was in a towering, a truly imperial fury of temper at the way he had been tricked. The Germans were able to brush his false identity aside at once, for he had belonged on his previous mission to Suttill's circle of intimates who were often seen dining together. But, once admitting that he was France Antelme, in spite of his rage he stuck to his second cover story. The Germans were anxious to discover from so important an agent all the details they could about F section and the coming invasion of France; but Antelme kept silent. His orders, he said, had been to join and work under Garry; Garry would have told him what to do; and he had nothing to say about anything or anybody else.

Antelme's intended role in France had been a triple one. Firstly, he was to investigate the security of the PARSON circuit round Rennes, which London rightly suspected to be in enemy hands; 'The circuit which we had established in Brittany has been completely broken up' was the first sentence of his operations instruction.¹⁹⁵ Secondly, Antelme was to arrange a double Lysander operation near Le Mans; and thirdly he was to establish himself anywhere he chose near Paris to the south, and set up a circuit there. As he was delayed in London for some weeks, there were several changes in his orders, including an instruction to look into the affairs of BUTLER, of which London seems already to have had suspicions.

But if London was already suspicious, why on earth, the reader will ask, were agents still dropped? At first sight it must appear that Buckmaster and his team were far too gullible. It is certainly true that staff officers who have been engaged for some years in this kind of work do get too ready to believe that geese they have trained are swans, and to make allowances for what look like accidental slips by busy people. The feeling 'But I *know* old So-and-so; he's all right – just a bit careless at times' is a natural though dangerous one. 'Country Sections', said a retrospective report by the security staff, 'were always full of an understandable optimism and a natural unwillingness to regard any agent as lost';¹⁹⁶ particularly if they had liked and befriended him. Several of F's staff had had personal experience in the field – Morel, Coleman, Bégué, and Le Harivel had all been to France during the occupation, though none of them recently (Bodington was away from SOE for six months after his return from Paris, lecturing on French politics to troops earmarked for the forthcoming invasion). There was some lack of imaginative perception of what things were really like in France, deriving partly from inexperience and partly from ineptitude. On the other hand, everybody in F section was extremely anxious to get on with the war; and though they frequently treated messages from the field with suspicion, if they treated every message with profound suspicion traffic would soon be brought to a standstill and they could not get on with the war at all. They had been doubtful about Noor Inayat Khan's set's traffic in the autumn; they were doubtful round the turn of the year about messages that purported to come from Rousset; but in each case their doubts were overcome, or at any rate overcome enough for them to risk sending agents as well as stores to both PHONO and BUTLER receptions, as well as to ARCHDEACON, which Goetz's ingenuity had given them no reason to suspect until Sabourin had been dropped.

A further difficulty in F section's way was the system of restrictive security on which SOE like any other secret service had to be run. This system had prevented anyone in F section from hearing of SEALING-WAX, the playing back of OVERCLOUD's captured wireless set against the Germans in 1942; it also should have kept F's staff from hearing of the doubts about NORTH POLE that were disturbing N section and the JIC by the autumn of 1943.¹⁹⁷ (The JIC was instructed on 1 December to investigate penetration of SOE, particularly in

Holland; its report, of 22 December, gave F section a 'satisfactory' clearance, as it was persuaded that frequent checks were made of F circuits' security. How it was so persuaded is unclear.) The judgement of F's superiors in the SOE hierarchy, who knew about NORTH POLE, was unaffected by knowing the agents too well, for they hardly knew them at all. Yet they were necessarily remote from the day-to-day business of running operations in progress; and this hindered them from noticing that anything was going astray in France. Some of the blame for F section's errors over these captured wireless sets can be laid on F's seniors, particularly on D/R, who was closest to the section, and knew about Dutch and gaullist affairs as well; but not much.

Moreover, though the Germans made fools of F section for some of the time, they did not always succeed. We noticed the case of Gilbert Norman a few pages ago, and there were several other promptly detected deceptions. And once F section headquarters had good reason to believe that a set was being played back by the Germans, it was often enough advisable to go on dropping containers and money to it. This was done with the dual object of lulling the Gestapo into a false security and of finding out precisely where it had its local and often unconscious reception committees organized. The purpose these wireless games performed for the allies was to concentrate the attention of the SD on a small group of bogus circuits, scattered over the old PROSPER territory about a hundred miles inland from any probable invasion area; and to concentrate it so much that they were quite unaware of much else going on. Goetz and Placke chuckled over the sizeable fortunes dropped to their receptions, or sent in on the persons of the agents they received. (These may be interjected in a table: see page 305.) The total, 8,572,000 francs – about £43,000, at 200 francs to the £ – was a tidy sum for a few individuals, but one that SOE as an organization could readily afford. For while Goetz and Placke were chuckling, Buckmaster and Morel were doing some deception in their turn. With the help of captured sets which the Germans thought they were playing back unknown to the British, F section was able to fill up the interstices between the SD's bogus reception committees in south Normandy with some formidable groups of which the Germans knew nothing. These were the revived HEADMASTER and SCIENTIST circuits, led by Hudson and de Baissac, scorched but by no means burnt-out survivors from earlier brushes with the authorities in France; Dedieu's PERMIT, and Henquet's HERMIT. De Baissac was dropped far to the south in February with a wireless operator, and moved up to the neighbourhood of Chartres where he established a vigorous working circuit which like many others played a significant and useful part in OVERLORD. Had it not been for the precise information about where the Germans' attention was centred gleaned from the wireless games, these missions in Normandy might have come to an early end.

One question remains to be answered: why was Antelme not dropped far to the south as well, to a WHEELWRIGHT or PIMENTO reception which was known to be perfectly secure; or why indeed was he not dropped blind?

TABLE IV: SUMS SENT TO CIRCUITS
IN NORTHERN FRANCE UNDER ENEMY CONTROL, 1943-44

(francs)¹

<i>Circuit</i>	<i>June</i>	<i>July</i>	<i>November</i>	<i>December</i>	<i>January</i>	<i>February</i>	<i>March</i>	<i>April</i>	<i>May</i>	<i>June</i>
ARCHDEACON	400,000	7,000	500,000		250,000		100,000	500,000	500,000	
BARGEE							500,000			
BRICKLAYER						1,280,000	500,000		250,000	
BUTLER				400,000			580,000			500,000
DELEGATE							500,000		200,000	
LIONTAMER										
PHONO					500,000	150,000				
PRIEST							405,000		250,000	
SURVEYOR						300,000				

¹ From *History* XXIV, F section, Appendix.
ORATOR'S money was presumably included with BRICKLAYER'S.

He particularly requested himself that he should be sent to a reception committee, because he had no friends left in France whose addresses and reliability he knew for certain.¹⁹⁸ No one as trusted as Antelme would be sent out blind against his own wish. The section staff, prisoners of overconfidence and habit, were rash enough to allow him to drop to the PHONO circuit in which he himself expressed confidence, though they did add to his operation instructions the order: 'It must be clearly understood that your communication with the PHONO circuit must be limited to your actual reception and the time needed for you and your W/T operator to proceed on your way. You will cut contact completely with the PHONO circuit at the earliest possible moment.'¹⁹⁹ Antelme's party was simply unlucky.

Morel had arranged with Lee also some indications that he was not working under German control; it was some while before this could be tested, as his set was silent for nearly a month. For the Gestapo had experience enough by now to impersonate most agents with little difficulty by wireless; and when they found themselves faced with Antelme, they evaded the problems posed by his strong character and decided personality with some ingenuity. The first message they sent by Lee's DAKS wireless plan, on 24 March, repeated a message they had sent by NURSE, that Antelme had injured his skull on a container as he landed; and a series of apparently authentic medical bulletins led to his 'death' without regaining consciousness at the end of April. In reality a nastier death awaited him in Gross Rosen.²⁰⁰ In this particular case the Germans were a shade too trusting, for they consistently employed Lee's security checks in the places he told them to do so, which were quite unlike the places prearranged before he left; and this time London did notice – three weeks later. Morel's suspicions about the DAKS traffic were aroused from the start, because the messages did not read quite authentically; and in mid-April he got the signals directorate to re-examine Lee's inward traffic – all marked 'special check present'; whereupon they discovered that they had made a mistake.²⁰¹ F section thus at last came to appreciate that 'the PHONO circuit is controlled, and has probably been controlled for some time'; but wished to continue wireless contact with it so that other circuits in the neighbourhood could have a clear run.²⁰² (That one of these other circuits, ORATOR, had also gone to a PHONO reception and was itself controlled seems to have been overlooked.) D/R approved this; but SOE's security and intelligence sections did not,²⁰³ and the traffic with BRICKLAYER, SURVEYOR, and PHONO was soon wound up, hardly before time.

The Germans seem to have been almost as slow in realising that the British had seen through their played-back wireless traffic as the British had been in realising that some of these sets were being played back at all. In April and May long discussions went on at the highest level – between Himmler, Göring, and Hitler himself – about the best moment to unmask to London the fact that some of SOE's apparently much cherished circuits were being worked by the Gestapo. In the end they decided to break the

news to the British whenever a major landing in north-west Europe took place; Hitler thought it would seriously unbalance the allied high command to discover at this critical moment that the resistance movements they relied on for support were penetrated by his minions. This shows how little grasp Hitler by then had of strategic or tactical reality; but it was an undoubted compliment to F section. Accordingly, on the BUTLER set, the SD sent a message to F at noon on D-day: 'Many thanks large deliveries arms and ammunition ... have greatly appreciated good tips concerning your intentions and plans.'²⁰⁴ They added a few notes about Antelme's and Biéler's health; and were dismayed to receive later in the day an instruction from the Führer personally not to send the message, because Göring had at the last minute persuaded him it would be inopportune to break the news yet.²⁰⁵ Buckmaster sent a jovial reply overnight: 'Sorry to see your patience is exhausted and your nerves not so good as ours ... give us ground near Berlin for reception organizer and W/T operator but be sure you do not clash with our Russian friends', and so on.²⁰⁶ This was all very well; but it was seven weeks before Woerther's WOODCUTTER and Pearson's PEDAGOGUE could be got onto the ground in Lorraine to try to make up for some of the time Goetz had managed to make Buckmaster waste over the false ARCHDEACON.

This was the end of the wireless game, but it was not the end of the story. Every single one of the F section agents who had been personally concerned in the wireless game, except for Rousset who escaped, and for John Starr who had the good fortune to lose himself in the crowd at Mauthausen, was executed. Most of them were killed at Gross Rosen concentration camp early in September 1944.²⁰⁷ Like any other secret service, the Gestapo shuddered at the thought that any of its methods might become known; but though almost all the allied agents were killed, almost all the responsible German staff survived the war, and systematic interrogation by Vera Atkins dug the story out of them.

Two conclusions are worth drawing at the end of this often wretched tale, beyond the obvious ones that some agents were braver, and some staff officers brighter, than others. The first is the time-worn but in this case justified plea of necessity; though as with greater disasters necessity in principle cannot justify errors in form.

Gallant men and women had to be found to preach armed resistance before an armed resistance movement could be got under way; and if they preached it under the Germans' noses in and round Paris, with the negligible security precautions which PROSPER'S leaders took, they must expect trouble. To the question why people with so little training were sent to do such important work, the only reply is: the work had to be done, and there was no one else to send. On 6 June 1944 a sacrifice was made on the Normandy beaches which represented a comparable spending of some lives to make straight the pathway for many more; though the later sacrifice has received none of the notice devoted to PROSPER – partly perhaps because no women

were on the spot, and because the whole forlorn business was over in an hour and a half; mainly because it was a recognisable part of an ordinary operation of war. Before the main invading forces could actually set foot, a little after sunrise, on the NEPTUNE coast, three battalions of British sappers had to go ashore at low tide with the first light of early dawn, and make safe the mine-laden obstacles strewn on the beaches. Three-quarters of them were shot down at their work; but they did it. Suttill and his colleagues were doing a similar indispensable pioneers' task; their fate was no more agreeable for being so much more protracted, yet their relatives also can feel they died to some good purpose. As someone said who fought at Arnheim, a larger splendid disaster,

There were mistakes, of course. There always are in a battle. And you can't help thinking about the men who died because of them. They might have been saved. But then, there would have been other mistakes and other men would have died. The mistakes are not so important now, except when they provided lessons for the future. The important thing is not to forget the dead.²⁰⁸

The other point that needs to be made has been touched on earlier, but it is worth repeating. The German authorities who gleefully spoke of the PROSPER arrests as 'our finest coup' spoke foolishly. Quantitatively they were right: they pulled in several hundred earnest men and women who would have given them a great deal more trouble had they stayed at liberty. But the crowning disaster to French resistance in midsummer 1943 was the arrest of Jean Moulin and his companions at that ill-fated house in Caluire, followed by the consequential raid on Serreules' flat: these losses disrupted the whole system for articulating a national uprising of the French people, and were of far graver consequence for the allied cause. Moulin's barbaric murder prevented the Germans from exploiting their own success as far as they would have wanted to do, if they had at first realised how great it was; but the troubles at Lyons were undoubtedly worse than the troubles at Paris.

Yet resistance by now was firmly planted in French soil; the worst difficulties were over, and the time to strike hard drew near. It is now time to pick up again the broken thread of the main narrative, which has reached midwinter 1943–44.

XI

Pressure Mounting: January to May 1944

Everyone knew an invasion of north-west Europe would have to be attempted from English bases some time in 1944. A few fanatics from Hitler upwards may have deluded themselves with dreams of German secret weapons that would knock England out of the war first. A few fanatics on the other side hoped that strategic bombing would make German resistance crumble away altogether; they allowed that even if it did there would still have to be an invasion, to take occupation of the conquered territory. Most ordinary serving men knew there was going to be a hard fight; and most French people expected, in hope and anguish mixed, that it would rage across French soil and set them free. A growing body of staff officers had been wrestling since the previous August with the intricacies of the OVERLORD plan, of which the core was NEPTUNE; a combined seaborne and airborne landing in the great bay west of the mouth of the Seine.

SOE's role in NEPTUNE had been sketched in outline by a special SOE/SO planning group as early as 30 August 1943: a preliminary increase in the tempo of sabotage, with particular attention to fighter aircraft and enemy morale; attacks on local headquarters, simple road and telephone wrecking, removal of German explosive from mined bridges likely to be useful to the allies, and more and more sabotage as the air battle reached its climax; and then, simultaneously with the seaborne assault, an all-out attack on roads, railways and telephones, and the harassing of occupation troops wherever they could be found by any available means.¹ This last injunction was bound to lead in places to guerilla; but guerilla was not called for in the original plan. And the planners were confronted over and over again with security spectres: for though everyone knew the fact of the impending invasion, unless the place and the date of it were kept particularly secret it would be a catastrophe. Therefore, until it began, much care was taken to keep SOE activity evenly spread over all the possible areas where a landing might be

made; in fact, to prolong the enemy's hesitation, care was still taken after NEPTUNE began to encourage him to think that another and a larger landing was to be made further east, and in this major deception plan called BODY-GUARD (later FORTITUDE) SOE also had some part to play. That part was to have included sending some organizers into the immediate hinterland of Calais in the spring;² here common sense fortunately prevailed. The area had been practically denuded of its normal inhabitants; it was crammed with sites for four different kinds of secret weapon, and consequently with specially watchful Gestapo; it was also full of troops, more or less alert. No SOE agent could have performed a useful task in it, least of all if he was – knowingly or unknowingly – to attract enemy attention; it was hard enough for professional intelligence agents prepared to disguise themselves as German clerks or labourers to get into it, and once there their survival depended on minimal activity outside their cover.

The proposal to send SOE teams to so unsuitable a spot shows how much these plans smelled of the lamp, and how little some of the planners were in touch with fact. A great deal more time and paper was expended on RANKIN, a series of proposals to suit various hypotheses none of which came true: all depended on the false assumption that the Germans were going to withdraw from the occupied western countries before they were invaded, either to strengthen themselves by shortening their line or because air attack and the Russian armies between them had broken their will to fight on. Hitler was not the sort of supreme commander who ever thinks of shortening his line; from his fastness near the Polish border he spent the winter vainly forbidding his generals to do so on the eastern front. Nor was Himmler the sort of police chief to let a nation's will to fight break easily; at new year's day 1944 the Germans had nearly eighteen months of combat left in them.

SOE rightly anticipated little difficulty in securing a noticeable sabotage effort about the time that the invasion began; many teams were trained and armed by the turn of the year, and numerous new or revived circuits were started up in the spring to arm and train more. What worried SOE a good deal more than support of the NEPTUNE assault was support of OVERLORD, the follow through. There was no doubt that the sizeable secret armies SOE now knew it could raise were woefully underarmed. Far too many of the arms caches built up in northern and western France by Suttill and de Baissac had fallen into enemy hands through the Germans' inroads into PROSPER and SCIENTIST; Brittany was in chaos; George Starr, Heslop, Cammaerts were flourishing, but far away; Suttill was in prison, Rée in flight, Biéler in danger; Trotobas was dead. On the RF side there was little more, indeed hardly as much, to show. The quarrel in the exiled French stratosphere between de Gaulle and Giraud was not yet over. The CNR, patiently constructed by Dewavrin and Moulin in the previous spring, had been shattered by the Caluire arrests; Yeo-Thomas and Brossolette had tried to rebuild the fallen fragments into a more solid structure, but there was not yet much to report.

The communists were raising a considerable clamour, but pistols apart they had few arms, and no prospect of more unless from SOE. The ingenious structures of the BOA and SAP had not so far had many successful arms drops to their credit; and a lot of the arms the BOA had collected had fallen into German hands before they were distributed.³

One reason for the arms shortage was bad weather; November and December 1943 and January 1944 were three successive stormy months, and Déricourt's February Hudson was by no means the only SOE sortie to be many weeks delayed. More fundamental obstacles were lack of aircraft and lack of will on the part of the allied high command. As the table on page 73 shows, there were still only 23 Halifaxes to meet all SOE's and other clandestine bodies' supply dropping needs over the whole of northern and north-western Europe; and the principal allied staff officers continued to show the conventional regulars' lack of confidence in irregular troops. Four different attempts to remedy these shortages were made early in 1944; between them, they had some effect. All aimed at the same target: Churchill.

The CFLN appealed formally to the chiefs of staff, who considered their request for a large increase in supplies to French resistance on 19 January; an application from SOE for a larger airlift to France was before them at the same time.⁴ Portal pointed out the difficulties that would attach to any weakening of bomber command while the night air battle over Germany was raging so fiercely – the Nuremberg disaster was still two months ahead; he had nothing to offer but some sixty sorties a month by 38 (Transport) Group's Stirlings.

The other attempts were less formal, and between them more effective. One was made by Emmanuel d'Astier, who decided that 'Without Churchill there was nothing to be done. The English secret services wanted to treat the French uprising as if it did not exist. Popular struggle meant nothing to them ... Like de Gaulle, Churchill was a hero out of the *Iliad*; the lone and jealous governor of the British war effort. To go and see the polite and self-effacing Attlee, or Lord Selborne, the affable Minister of Economic Warfare, or Duff Cooper ... or Clementine Churchill ... or Macmillan, or Churchill's secretary Morton, or General Gubbins, the mysterious manipulator of the initials SOE (Subversives Operations Executive); to go and see them was useless.' For only Churchill's authority, fired by imagination or anger, could make any real impact on what the British did.⁵ So d'Astier dared to beard him, both when he was convalescing in Morocco on his way back from the Tehran and Cairo conferences and when he returned to London. D'Astier had direct acquaintance with resistance work, and could give some personal account of the probable military worth of resisters; he could speak eloquently, and was strongly moved. On one of his visits to Downing Street he happened to meet another man who had worked in the field, a man who felt equally strongly and had seized on a chance to get past the proper channels into Churchill's presence: Yeo-Thomas.⁶ Yeo-Thomas could also

speak well, from direct personal knowledge of what was going on in France; and Churchill's romantic character could not fail to be stimulated by what Yeo-Thomas had to say.

The other intervener was more obscure, but more important. A quiet, grey-haired, unassuming man who looked like a substantial merchant, he went then under the field name of '*Jérôme*', his real name was Michel Brault, who had been Mme Carré's lawyer. He had got away from Paris in time in 1942, and worked unostentatiously in COMBAT in the Rhône valley. He had taken on for several months, at the CNR's request, a big task of resistance administration: the running of the *service maquis*, a sort of clandestine relief organisation covering all the large maquis in France. Brault did his best to assure them supplies of food, medical stores, and clothing. This task was of political as well as military importance. For the more thoroughly he could carry it out, the less the maquisards would be inclined to endanger themselves and exasperate their neighbours by pillaging forays; and the execution of it began to gear the commercial life of France to the gaullist instead of the vichyste system. Yeo-Thomas had only visited three or four maquis; d'Astier had never lived in one; Brault had visited dozens, knew exactly what he was talking about, and could expound in practical detail what the maquis' needs and possibilities were. Moreover he had a strong card of entry. For Dismore, Brook, and Gubbins in turn were impressed by him when he came to England by air at the beginning of the year; Gubbins introduced him to Selborne; and Selborne took him along to see Churchill.

The Prime Minister was predisposed to listen to any stranger introduced by an old friend; and Brault struck sparks from him. Someone in his office was still spelling maquis with a c – Macquis, as if they were a remote Hebridean clan; this did not last. On the afternoon of 27 January Churchill held one of those barely formal committee meetings at which so much English business is done. It was called a 'meeting of ministers', although Selborne and Sinclair were the only other ministers present. Sinclair was backed by Portal; Selborne by Sporborg and Mockler-Ferryman; and the Prime Minister by Morton. Speaight and Mack attended from the Foreign Office; and d'Astier and Boris from de Gaulle's headquarters, though not subjects of the Crown, were present also as equals. D'Astier has published the minutes.⁷ After an opening statement by Churchill that he attached high importance to French resistance, d'Astier 'gave an assurance that the arming of Underground armies in France would not result in the intensification of political rivalries among Frenchmen. At present the movement with which he was concerned was devoting its entire energies to attacking the Germans.' This was a wise assurance to offer, for the British Cabinet feared of course another Tito-Mihailovič quarrel placed in their lap by SOE, in a strategically even more critical area. D'Astier added that resisters were currently killing two Germans for every man they lost – a bold, unverifiable claim; and that the maquis were in acute danger for lack of arms. Churchill, kindling,

envisaged a great guerilla redoubt east of the Rhône: 'Brave and desperate men could cause the most acute embarrassment to the enemy and it was right that we should do all in our power to foster and stimulate so valuable an aid to Allied strategy.'

Everything turned on aircraft availability, and to this the rest of the meeting was devoted. Sinclair was anxious to help, but anxious also to avoid precise commitments; Portal was anxious to press on with POINTBLANK, the bombing of Germany. He observed that two American squadrons would begin clandestine work as soon as weather allowed,⁸ and that some help would come also from 38 Group. In the end, it was settled that bomber command's main effort was still to be directed on Germany, but that in its subsidiary operations drops to the maquis were to have first priority, followed by other operations for SOE; attacks on secret weapon sites (CROSSBOW), and sea mining, in that order. The usual reservation was made that these activities must not prejudice the needs of the intelligence services; coyly defined by d'Astier in a footnote as 'tripartite franco-anglo-american operations against the enemy's rear'.⁹

A good deal of flurry followed. Early in February, Dewavrin in a gloomy conversation with Dansey doubted whether as many as 2,000 men could be found anywhere in France who would be prepared to act together in a guerilla offensive at invasion time; though he added that there was still unexploited potential available in France, so that groups of under a thousand people might suddenly grow to a strength of over 10,000, if once presented with arms and opportunity.¹⁰ Some use was made of these remarks in one of the strongest of many attempts made by other secret services to get the air effort for SOE cut down, on the ground that it intensified Gestapo activity and so endangered all clandestine agents. Unluckily for SOE's rivals, the Prime Minister was currently captivated by his enthusiasm for the 'Macquis'; the attempts foundered; and SOE got as many aircraft for France as Harris and the weather would allow.

Churchill's enthusiasm, indeed, led him for a few days to try to busy himself with the details of organizing operations that he would better have left to the junior staff officers who knew how to handle them; Selborne, Morton, and Ismay had some trouble in fending him off. Weather prevented much activity in February, but March was a busy month, and April and May busier still. The shorter nights began to limit operations in May; but the first half of 1944 showed a distinct improvement on the second half of 1943. As Table VII in Appendix C shows, sorties to France – dropping and pick-up together – improved from 107 in the last quarter of 1943, through 759 in the first to 1,969 in the second quarter of 1944. The largest of these figures includes 177 American sorties for the first of the great daylight drops after D-day, and a substantial number of other sorties flown after NEPTUNE had begun; even so, the increase was marked.

Daylight drops had been looked at for a moment in February, as an alternative means of supply in bad weather. As air superiority over France, the

indispensable prerequisite for the invasion, had yet to be secured, the Air Ministry turned the proposal down, saying it was bound to lead to unacceptable casualties. The Prime Minister, annoyed by a Vichy wireless report, began to complain to Selborne of lack of zeal by the French, which had led some drops into the wrong hands; SO submitted in reply that the rate of wastage on the reception grounds – under five per cent – ‘was rather less than might have been expected’, ‘and Churchill let this complaint rest, though he continued to keep an eye on the subject.’¹¹

One dropping experiment was made in February – 220 containers of arms were parachuted through cloud into an area in Haute Savoie believed to be under Heslop’s control; but a larger proportion than usual was collected by the enemy, and this was not tried again. Eleven American aircraft made a daylight drop on 10 March into the Tarentaise, the upper Isère valley south-east of Annecy;¹² this appeased Churchill, but inevitably drew German attention also.

All this air effort amounted, by the middle of May, to the arming of about 75,000 men by F section and 50,000 by RF, at the most optimistic estimates;¹³ and these figures took no account of the arms captured in any of the Gestapo triumphs that had disfigured 1943, which probably reduced the totals of available armed men by something like a third. Moreover, there were no adequate supplies of ammunition: Brault’s opinion was that by the end of April hardly 10,000 maquisards had ammunition for more than a single day’s fighting¹⁴ – after all, unskilled troops are notoriously lavish with ammunition, and the Sten’s rate of fire did not encourage economy; besides, it was so inaccurate that a whole magazine might well be needed to hit a man at a range of more than a few feet.¹⁵ On the other hand, one day’s fighting might be all that was needed to capture a headquarters, or blow up a railway junction, or impose a critical delay on an important enemy column on the road; and if the French were still short of arms and ammunition, they were long by now on morale and fighting enthusiasm. Von Rundstedt even went so far as to claim in retrospect that ‘From January 1944 the state of affairs in Southern France became so dangerous that all commanders reported a general revolt. ... Cases became numerous where whole formations of troops, and escorting troops of the military commanders were surrounded by bands for many days and, in isolated locations, simply killed off. ... The life of the German troops in southern France was seriously menaced and became a doubtful proposition.’¹⁶

The maquis grew as the spring got warmer, and living alfresco in the hills became more of a pleasure and less of a battle against the elements. There were many maquis in central and southern France so small and so secret that they were never in touch with any SOE or BCRA organizer, or even with the *service maquis*; their sole object was to keep their members clear of work in Germany, and if – a big if – no one who knew of them spoke of them outside, they survived. Larger maquis such as Heslop’s in the Ain or

Mesnard's in upper Savoy were more offensively minded, and drew counter-offensive ripostes from the Germans. These could be devastating; Rosenthal of CANTINIER reported that in the three midwinter months of 1943–44 the Germans had burned out as many as 500 farms in the single department of Haute Savoie.¹⁷ But though this scale of reprisal was guessed at in London, it was not accurately known; nor indeed was much known there till Brault's arrival about what military potential, if any, the maquis might be able to deploy. Yeo-Thomas had only been able to report in the previous autumn that Brault was in touch with 6,000 maquisards north and 12,000 south of the demarcation line,¹⁸ though Brault's own figures were 14,000 higher; he claimed 32,000 in all.¹⁹

RF dropped into France on 6/7 January an inter-allied mission called UNION which was expected to throw light on just this point, particularly where south-east France was concerned (the BCRA's regions R1 and R2). Pierre Fourcaud the commander, an old gaullist intelligence hand who had been in and out of France on allied business more than once already,²⁰ was no longer fit to parachute, and arrived later; Thackthwaite of RF section staff took charge meanwhile of Peter J. Ortiz, formerly of the foreign legion, and of Monnier, 'one of the bravest and most discreet wireless operators sent out to France'.²¹ Their main task was to impress on the maquis leaders in the Drôme, Isère and Savoie 'that organization for guerilla activity especially on or after D-day is now their most important duty'.²² Though they dropped in plain clothes, they took uniforms with them, and Thackthwaite claimed them as 'the first allied liaison officers to appear in uniform in France since 1940'.²³ Ortiz, who knew not fear, did not hesitate to wear his US marine captain's uniform, in town and country alike; this cheered the French but alerted the Germans, and the mission was constantly on the move.

The largest single maquis they found was in the Vercors. This plateau, some thirty miles by twelve, lies hidden behind a stiff rock barrier south-west of Grenoble; most of it is over a thousand metres high. Some of it is good farming land, on which about 5,000 people were settled at the time; it also includes one of the largest forests in western Europe, then said, probably wrongly, still to hold bear. It was obviously suitable as a maquis base, and was treated by the regional resistance authorities as if it were an independent department (it lies astride the boundaries of the Drôme and the Isère). Here Thackthwaite found about 3,000 maquisards, on top of the ordinary population. Five hundred of them were already lightly armed and organized in groups of ten; but they included 'men used to heavy arms ... [who] could be formed into a HQ company if supplied with Vickers, mortars and Piats ... *No Stens, they have enough already.*'²⁴ UNION was able to make some useful improvements in the liaison arrangements between the Vercors and regional headquarters in Lyons. F had good reports of the Vercors as well; Cammaerts visited the plateau several times, and an April report of his chimed in with Thackthwaite's of a month later. He said the Vercors had 'a

very finely organized army'; but 'their supplies, though plentiful, are not what they need; they need long distance weapons and antitank weapons'.²⁵

The French, kept outside the general run of detailed planning for OVERLORD by security bans they keenly resented, even if they accepted them as unavoidable, were continuing to elaborate plans of their own. The favourite among the regular French army officers who became more and more numerous in Algiers and London was named after the vanished Delestraint, VIDAL. Under this plan, large maquis groups were to seize control of defensible areas of ground and defy the Germans to drive them off. Such a concept of seizing and holding a fixed point in space was a natural one for regular soldiers to develop; the idea was attractive to many resistance politicians also. Frenchmen, like Serbs,²⁶ wanted to wrest some tangible part of their homeland from the Germans by their own unaided efforts, and to construct on it a redoubt that the heroism of the local population could defend indefinitely. This might have been a sound policy in the conditions of the peninsular war of 1807–14 that made the name and nature of guerilla familiar to the French;²⁷ over a century and a quarter later, the disparity of weapons had grown too great for the old concepts to keep their validity. In normal circumstances the task of the modern guerilla is to hamper the enemy's passage across ground, not to hold it. The fascination the plan VIDAL exercised on the gaullist high command boded no good for the Vercors.

A few lessons on these doctrinal disputes might have been learned from FIREBRAND, the liberation of Corsica in September–October 1943. *Maquis* after all is the Corsican name for the thick local brushwood, and Corsican partisan forces made extensive use of it. They were assisted by twenty-six SOE agents sent in from Algiers, seventeen by sea and nine by air; and three SOE instructor officers were with the SOE-trained French *bataillon de choc* which landed at Ajaccio on 15 September and drove the last Germans out of Bastia on 4 October. This battalion secured on the whole better results than the partisans, because it split up into small groups of three or four men who chose targets, pounced out of cover to attack them, and then melted into the landscape; while the partisans were unable to resist the temptation to gather in larger bodies for attack, thus presenting targets that German counter-attacks could get their teeth into. The gaullists in London may have discounted any lessons from Corsica because Giraud directed French operations there;²⁸ though Hutchison made a rapid tour of the island, immediately after its capture, to see what lessons he could glean for the conduct of guerilla delaying parties on the mainland.

In the spring of 1944 the Giraud-de Gaulle dispute faded away. Giraud was visibly weakening, and eventually in April retired altogether from the struggle to which he was unequal. The gaullists took over many of his staff in North Africa, and this further weighted 'exterior resistance' in the direction of military conservatism. Yet the hold of the French commanders of 'exterior resistance' over the forces of 'interior resistance' was still not established on

any durable foundation. This was an internal French political problem, in which SOE nevertheless was necessarily interested and a good deal involved.

At the next level down, there was an acrid dispute between Emmanuel d'Astier and Dewavrin over the control of secret services, ably summarized by Sebastien Laurent in an article.²⁹ De Gaulle accepted the republican principle that these services must come under civilian control, and abandoned Dewavrin his faithful servant; who was fobbed off with the post of joint chief of staff to Koenig, the commander from abroad of the *Forces Françaises de L'Interieur*.

A marked political consequence followed. The French communist party launched this spring a keen attack on the whole gaullist movement, steering clear of onslaughts on the general himself but losing few opportunities to denigrate his followers as a pack of crypto-fascists whose real aim was to rivet the rule of the *deux cent familles* back onto a resuscitated capitalist republic. The increment of giraudists, most of them politically far to the right, came at a moment particularly convenient to the PCF. A lot of mud was thrown, and a little of it – as always happens – stuck. For there was as usual a grain or two of truth in the communists' heap of lies. There *was* a genuine reluctance on the part of all regular soldiers west of Yugoslavia to trust resistance forces; regulars thought them militarily unreliable and discomfortingly far to the left. Conservative politicians in many allied countries took the same view, and were strengthened in it by the prominent role communist parties everywhere took in resisting the country that had invaded the soviet homeland. Paradoxically, it was (among other reasons) precisely because there were communist members of the CFLN that the principal British and American directors of the war were less than enthusiastic in their support of de Gaulle. Churchill's minute to Law and Cadogan of 13 April, is telling on this point:

You will remember that we are purging all our secret establishments of Communists because we know they owe no allegiance to us or to our cause and will always betray secrets to the Soviet, even while we are working together. The fact of the two Communists being on the French Committee requires extremely careful treatment of the question of imparting secret information to them.³⁰

Practical men like to think you can no more have three sides in a war than you can have three sexes in a bed. Some of the complex situations SOE's agents were involved in, in France as in south-eastern Europe, indicate this proposition may not be valid.

BRAL's staff of practical men pressed on regardless, preparing for an insurrection in France that would coincide with the invasion of which they continued to know nothing, and determined to bring the rising under gaullist control if they could. In March 1944 de Gaulle decreed the formation of the FFI, the *Forces françaises de l'intérieur*, the army of the new France that was

to be. 'Local clandestine activities', he said later, 'had to take on at the right moment the character of a national effort; had to become consistent enough to play a part in allied strategy; and, lastly, had to lead the army of the shadows to fuse with the rest into a single French army.'³¹ His condition for incorporating into the FFI the resisters in France who would follow him was that they should accept integration into the French army's hierarchy of ranks. '*Formez vos bataillons*' follows '*Aux armes, citoyens*' in the French national anthem; but the point laid a severe burden on RF's wireless operators, who were inundated with arguments about who was to bear how many *galons*. Regimentation was easily enough accepted by everyone else outside the FTP. Within that powerful organization, the core of communists in the lead mistrusted all established authorities outside the USSR; they could not rid themselves of a mistrust of the BCRA as profound as the BCRA's mistrust of F section, and quite as misconceived. Hardly any FTP units incorporated themselves in the FFI, except in a purely formal way; hence the main division observable to the allied troops who found themselves, in the end, in contact with resistance units in the field. On the whole, those Frenchmen who were ready to accept de Gaulle's lead from outside France served in FFI groups, and took their orders from Koenig, one of the group of promising young officers de Gaulle had gathered round him; Koenig was appointed to command the FFI in April, and went to London to place himself at Eisenhower's disposal. Thackthwaite observes sourly of the growth of the FFI's London staff that 'The old resistance stalwarts such as Robert, Brault, Duclos'³² and even *Passy* were set aside or given subordinate jobs, and with the new order in London came a lowering in the quality of appointments in the field and the exasperation of the older resistance elements, none of which made for greater efficiency.'³³ This was not Koenig's fault, but the system's. People in France who were suspicious, for any reason, of external resistance gravitated to the FTP, and looked for their orders to COMAC the action sub-committee of the CNR.³⁴ Two of COMAC's three members – Valrimont (*Kriegel*) and the chairman, Pierre Ginzburger (*Villon*),³⁵ not de Vogüé – were in fact communists. The divergencies in view between internal and external French resistance were thus perpetuated to the end; nothing SOE could have done could have made any difference to this.

The divergencies expressed themselves in a divided command over the forces of resistance in France. A serious division between F section's forces and those of more strictly gaullist allegiance, long foreseen and feared, never in fact occurred. It was prevented by the readiness of all the important F organizers to support de Gaulle before D-day, and by the amalgamation of F's with the BRAL's agents under EMFFI afterwards. The real division was between those who looked direct to COMAC and the CNR, and those who looked direct to the delegates of the CFLN. This division, clear from the various organization diagrams published in France after the war,³⁶ was made definite by the military appointments instituted by de Gaulle this spring.

He thought it indispensable for an army to have commanders on the battlefield; now that the main resistance movements had been incorporated, nominally at least, in the new FFI; it was no longer suitable for them either to devise their own orders, or to receive all of them *seriatim* and separately through RF's wireless channels. He had appointed earlier two *délégués militaires de zone* – just the posts SOE had so strongly opposed in the previous autumn:³⁷ for the old ZO, to replace Morinaud, Colonel Rondenay (*Sapeur*), who was shortly captured and shot – silent, and replaced by Colonel Ely (*Algèbre*); for the former ZNO, *vice* Mangin, Maurice Bourgès-Maunoury (*Polygone*). And above the two DMZs he now placed a *délégué militaire national*, Jacques Chaban-Delmas (*Arc*), an active though junior treasury official. Bourgès-Maunoury was Soustelle's original choice for the more senior post, of D M N; the British refused to agree to his nomination, in spite of his excellent record as a DMR round Lyons, because he was still under thirty. They accepted Chaban-Delmas at his suggestion, without discovering that he was half a year younger still.³⁸

At a lower working level, RF's main task, under the dual guidance of Soustelle and Gubbins, was to get as many organizers into France as could be, and to keep the multifarious tentacles of the BOA and SAP not only in being, but supplied with arms. By D-day, the total of air operations officers and other senior assistants working under the six DMRs in the old ZO was 32; 12 more worked under the other six DMRs in the ZNO; 61 sabotage instructors and 104 wireless operators were there to help them besides special missions to the maquis and to trade unions, especially railwaymen.³⁹ Among these people – colourful detail – were a number of women, for the BCRA and RF had by now been impressed enough by F section's results to employ a few sensible women as wireless operators and couriers. None of the eleven they sent to France⁴⁰ has attracted any of the notoriety suffered by some of F's girls; in part no doubt because they all survived, and because they ran risks many thousands of other gallant Frenchwomen ran, so that they were less exceptional in their home society than F section's FANYs and WAAF's were.

Almost everybody in France who seriously wanted to take orders from de Gaulle knew of, or could without too much trouble discover, the existence of the DMRs, and so make contact with him.⁴¹ But the DMRs' network was not a close one. Equally, the sparse network of F's organizers made it feasible for any French body that seriously wanted to do so to get in touch with the allied high command direct.

Parallel with their growing network of military delegates, the gaullists strengthened and developed their political organizations in France, which all depended on the delegate-general: his post was one of great danger.

At the turn of the year, the reader will recall, Brossolette and Bollaert were both still in France, though hoping for an early journey to England. No aircraft could get across to pick them up, because the weather was so

bad; in despair, they turned to a Breton sea escape line. They embarked safely, but their boat was shipwrecked. They scrambled ashore, early on 3 February; a few hours later they were marked down as strangers by a quick-witted Feldgendarme, and pulled in for questioning at Audierne.⁴² Their papers were not in perfect order; they were held.

Yeo-Thomas, hearing of this, at once insisted on returning to France, to attempt Brossolette's rescue before his friend's tell-tale streak of white hair grew out below the dye and revealed his identity. Even when he had come back, by so narrow a margin, from MARIE-CLAIRE, Yeo-Thomas had concluded his report by advocating that he should be allowed to cross to France again, to ensure continuous liaison between London and the field. For his next mission, ASYMPOTE, he again took the field name of *Shelley*; he was given a long list of instructions to carry out in France, but a pair of escape clauses let him omit any that were inconvenient and undertake any other investigation 'which he judges to be of importance to the prosecution of the war'.⁴³ So, parachuted late in February, he took up promptly a plan for getting Brossolette out of Rennes prison. A double disaster followed. Yeo-Thomas's arrangements for a cutting-out operation at Rennes took too long, and involved him with too many people. The Germans did recognise Brossolette, and moved him to Paris, for questioning in the Avenue Foch. Like Noor Inayat Khan, he escaped through a lavatory window within a few minutes of arriving; unlike her he lost his footing, or jumped, when challenged, fell five storeys, and was killed.⁴⁴ Yeo-Thomas, knowing nothing of this, was betrayed by an arrested subordinate, and captured by the SD on the steps of the Passy métro station, almost under the windows of his father's flat. Appalling tortures followed; quite without useful results for the enemy.

As soon as Bollaert's disappearance was known – it took, of course, a little time to discover – Bingen, who was still in France, again took over *ad interim* the running of the delegation's affairs. But Dewavrin, who liked him and admired his courage, thought him too nervous; and Dismore thought him insecure. In April he was demoted, to become assistant delegate-general for the former ZNO; in this capacity he fell into German hands at Clermont-Ferrand a month later. Whatever people thought of Bingen's politics or security, it is hard to deny the heroism of his end: fearing he might talk, he swallowed his cyanide pill, and died immediately – silent.

Bollaert's eventual successor, chosen by the CFLN, was Alexandre Parodi (*Quartus*), a civil servant dismissed by Vichy who was ostensibly a member of the conseil d'état, actually a founder-member of the CGE and an active resistance planner.⁴⁵ Parodi hesitated to take on the crushing burden of the delegacy; not from fear of hard work or danger, but from modesty and from ignorance of the main personalities in the resistance world, either in France or outside it.

To induct him into his new role, de Gaulle mounted one more politico-military mission, CLE, a one-man affair as important as it was small. Its only

member, Lazare Racheline (*Socrate*), had been much concerned in the Mauzac escape and in setting up the main VIC line structure in 1942; he had been withdrawn from France late in 1943 as too well known to the Gestapo of Lyons. For this reason, SOE's security section forbade his return to the field. How the gaullists who needed him got round this ban is not recorded; but somehow they did, and he went to France in mid-April on the last VAR sea crossing. (Ely travelled back to France with him.) His principal task, after persuading Parodi to buckle to – which the delegate most willingly did – was to help him in securing as much decentralisation as possible. He was particularly charged with ensuring that Parodi and his principal military assistants, Chaban-Delmas, Ely, and Bourguès-Maunoury, all understood the folly of any attempt to precipitate a national insurrection the moment the allies landed.⁴⁶ Like Gerson his instructor in clandestinity, Racheline had learned to be discretion incarnate, and his advice on how to behave must have been valuable to Parodi. Racheline returned to England after only four weeks in France, by his own old VIC line; setting a new record by getting from Paris to London through Spain in six days.

While CLE was in progress, there occurred a tiresome but necessary contretemps between the gaullists and the British, which SOE could have done nothing to avert. As the date of OVERLORD drew near, it was held indispensable by various high authorities, from the Foreign Office and SHAEF downwards, to prohibit all cipher traffic between England and the rest of the world unless it passed in British, American, or Soviet ciphers. Coming so soon after the 'great coding row', this seemed to the Free French like a deliberate insult. The insult was the more keenly felt because their whole machinery for command of special operations in France was divided between Algiers and London; an inconvenient division, but one made necessary by the facilities in England for communication with France, while political reasons kept the CFLN's headquarters in North Africa. The committee's members might wish to work in either city, and they and their subordinates were affronted when a travel ban as well as a ban on cipher traffic was imposed. Selborne, Sporborg, and others took great trouble to explain that no insult was intended; and the French had to accept the rule like the rest. Agents cleared by security were allowed to travel to the field; no one else was allowed out of the country, and de Gaulle was pinned in Algiers till on 3 June, at Churchill's personal request, he and a small suite were brought back to London. Personally, again, he was allowed to communicate in cipher with his committee; which that day proclaimed itself, with his entire agreement, the provisional government of France.

This proclamation provided a formal, institutional framework for much of the work being done, in France and in Algiers, by leading resistance politicians. But before we leave the gaullists' work in this last spring of preparation before the final crisis, we must glance at one or two other less exalted projects in which RF section had a hand.

The section mounted two more missions, both following UNION'S pattern though in different areas. CITRONELLE'S⁴⁷ advance party dropped in the Ardennes in mid-April, to seek out maquis along the Franco-Belgian border and put them in touch with London and with weapons; Bolladière its commander could only make slow progress.⁴⁸ BENJOIN in the massif central, parachuted on 8 May under Cardozo, worked with less trouble in a part of France less full of secret police. Its task was to get in touch with a large group of maquis known to exist in the Auvergne mountains under a leader called *Gaspard*, who kept himself to himself; to find out where *Gaspard's* allegiance lay, and if practicable to enlist such forces as he could command under allied strategic direction.

South of BENJOIN, an F circuit called FREELANCE was engaged in just the same task from 30 April. This crossing of lines was not as bad as might appear; *Gaspard's* area was large, and London thought he might well need two operators at least to keep him supplied, as well as more than one party of people looking out for suitable dropping zones in hilly country. The adventures of FREELANCE, whose organizer confusingly enough was named Farmer, are celebrated in Russell Braddon's jovial paperback on Mme Fiocca his Australian-born courier, much better known under her maiden name of Nancy Wake. She had got her training in the PAT line; her irrepressible, infectious high spirits were a joy to everyone who worked with her. Denis Rake, another experienced clandestine, was the wireless operator. Farmer and Cardozo met on 17 May and agreed to co-operate; *Gaspard* (whose real name turned out to be Coulaudon), puzzled by the arrival of both of them, was willing to use all comers to equip a private army over 5,000 strong.

SOE, through RE, also provided the initiative for a striking coup, mounted by the ARMADA team, still pursuing their relentless way across Burgundy and the Lyonnais. It formed part, in France the only successful part, of an operation called RATWEEK, a riposte by SOE all over occupied Europe against the SD that had been so troublesome to it. RATWEEK'S object was to kill as many senior Gestapo staff as could be found in the last week of February. *Chaland*, the crack shot who was ARMADA'S driver – his cover job was to drive a taxi – disposed, in and round Lyons, of eleven.⁴⁹

By this time the whole business of sending clandestine agents into France had developed qualities of routine, on the senders' side, FANYs at the holding school, conducting officers, briefing officers, dispatchers continued to treat every agent they saw off as an individual, but this too had become part of the drill. In all 1941, F section had only sent 24 operational agents⁵⁰ into the field; by the end of the five months this chapter covers, over 40 separate F circuits, most of them with several British-trained agents, were at work. As this book is a history, not an encyclopaedia, it cannot carry details about all of them and their doings, and the remaining narrative will concentrate on the more interesting circuits and personalities. Yet as this is the nearest F's or DF's agents are likely to get to a regimental history, the courtesy of

passing mention at least is due to those of them who embarked on one of the most nerve-racking tasks of the war. Hence a little in the following pages of the mere listing the narrator has so far done his best to avoid.

The survey of the smaller sections must begin by such a recital. DF mounted two new lines across northern France to supplement PIERRE-JACQUES and GREYHOUND; STANISLAUS under Jeschke,⁵¹ and LOYOLA a Polish group under the sad-faced, self-effacing Popiel. The VAR sea line's origins and a few of its activities have been noticed already, as has its transformation into a land line in May.⁵² VIC remained the largest and busiest of DF's circuits, and though it had more troubles with the Germans at the beginning of the year it survived them.⁵³ DF's whole section in fact had by now taken its assured place in the structure of SOE's war machine.

EU/P had, as usual, little to report. A lot of work was being done to prepare BARDSEA, a project for injecting a hundred highly trained Poles into the neighbourhood of Lille when the moment was ripe, and discussions with the exiled Polish government in London were already going on about the exact circumstances in which the BARDSEA parties could be dropped. The British remained in the dark about MONICA, the long-standing Polish organization in France. Chalmers Wright, transferred from PWE, made a second journey to France in January – travelling in over the Pyrenees by a DF line against the usual flow of traffic – and returned in April. He brought back some first-hand news of MONICA'S potentialities. There were about 5,000 men in its northern group, including over 3,000 miners in the area of Lille and Valenciennes, fully and securely organized, but ill equipped with precise targets, unable to develop any mobility, and practically without explosives. Though they had no plastic, they could get unlimited dynamite from the mines; yet professed themselves unable to secure detonating batteries for it. The Polish political complications were such – for the Polish ministries of national defence and of the interior were still at loggerheads – that SOE could do little to activate this apparently promising mass of men. Indeed the nightmare might have visited Chalmers Wright, as he scribbled his early April report against the clock in the Barcelona consulate, hoping to catch the first bag home,⁵⁴ that he had just emerged from a gigantic talking-shop, a vast international confidence trick. He would instantly have dismissed the thought, as an unworthy reflexion on people who were bound to be left living under alien rule whichever way the war went; so that they might well be forgiven for keeping post-war political possibilities much in mind, and for a proper reluctance to run avoidable risks. But MONICA'S effort remained potential.

The JEDBURGH parties, clamouring to leave, were held in a training school near Peterborough; their anxiety to be gone was the only worrying thing about them. The SAS brigade was forming farther north, in Ayrshire; the 1st and 2nd SAS Regiments, returned from the Mediterranean, were training in the Lowland hills and getting to know the two French regiments,

the 1er and 2e RCP, and the PHANTOM squadron and Belgian independent company brigaded with them under R. W. McLeod. McLeod, one of the few British regulars to take an informed interest in clandestine war, was almost the only professional British officer in the brigade he commanded.⁵⁵

F section, meanwhile, was in the thick of operations; the five months this chapter covers marked the climax of its activities. At the start of the year it suffered a serious casualty. As chapter X showed, the Gestapo was much concerned with its affairs in the ZO, and in one spell of four weeks – 8 February to 8 March – collected eighteen new arrivals from various wireless games.⁵⁶ Their other main source of captives, direction-finding, led them in mid-January to Yolande Beekman at St Quentin; Biéler her organizer was taken with her. The MUSICIAN circuit was thus shattered, just as F was hoping it would expand. P. R. Tessier (*Théodore*, later *Christophe*) had been parachuted to Biéler on the 10th, as an assistant; he had been in France in the previous August, on one of the unsuccessful DRESSMAKER raids in the Tarn, and was to have helped Biéler demolish the locks on the St Quentin canal. He too was arrested, a week after his arrival; and several of the best of the local people were caught as well.⁵⁷ These arrests left an important area open; F section made a number of attempts to cover it. The most successful of these was SPIRITUALIST, the circuit of the brave and cunning René Dumont-Guillemet (*Armand*, formerly *Mickey*), a well-connected Frenchman of thirty-five. He dropped blind on 5/6 February near his own place in Touraine, taking Diacono (*Blaise*) with him as wireless operator. They had a weird range of tasks, including organizing a mass escape from Fresnes and – hardly less complicated – kidnapping an individual German believed to be an expert on the V 1 rocket that was worrying the British so much at the time; luckily they also had plenty of common sense and working capacity. They pressed on with their most important task, knitting up again the touch with FARMER that Trotobas' death and Biéler's arrest had broken. They managed to set up reasonable supply lines, to work from dropping grounds of their own quite close to Paris to reliable bodies of saboteurs in Trotobas' old organization near the Belgian frontier; these ran either by lorry or by goods train, under suitable camouflage to see them past inquisitive Germans on the way. These lines made some use of MUSICIAN'S railwaymen, were quite secure, and kept FARMER'S saboteurs busy.

On top of this useful work Dumont-Guillemet tried something more perilous; though not as perilous as his freak original missions, which he was sensible enough to abandon. The PROSPER and INVENTOR disasters were by April far enough in the past for a few tentative inquiries among their wreckage to be safe. Dumont-Guillemet began with some cautious probes, and went further when they succeeded; he resolved to start again the task of setting up an F circuit in Paris itself. He did a lot better than de Vomécourt or Suttill had done before him, because he kept clear of the German security services; they, busy with more distant ploys, did not suspect this danger near

their doorstep. But his circuit held less promise than the FTP groups in the industrial belt round Paris, which could rely as he could not on steady mass support in their own neighbourhoods; and because he was an F section man he was cut off from the centres of power and controversy of the internal resistance movements, where people were girding themselves for the imminent task of seizing power in France's past and future capital. Dumont-Guillemet observed and despised the café-conversationalist resisters who teemed in the city; their meetings reminded him of nothing so much, he said, as election agents' bargaining sessions.⁵⁸ He collected a force of 1,500 stalwarts for whom he had arms, and backed them with another 5,000 men whom he would arm if he could; they came from all sorts of groups, left, right, and centre. When they joined SPIRITUALIST, they undertook to leave their previous coteries and to steer clear of party politics, and took an interesting engagement: 'I pledge myself to reveal to no one that our organization exists. I swear I will hold myself, night and day, at the disposition of the allied armies. I swear loyalty and obedience to the leaders I have freely chosen. I know any backsliding will be punished by death.'⁵⁹

That last sentence was not an idle threat. Dumont-Guillemet had always taken care to get accurate intelligence about the enemies he was dealing with, and inquiries about the fate of his friend Sidney Jones had put him on the track of a number of German double agents who were trying to penetrate resistance. Some of these he was able to liquidate. During his own travels in Flanders and Picardy he several times heard of a Canadian officer who had preceded him, dispensing promises of arms and largesse; this of course was Placke, impersonating Pickersgill. French police assistance provided Dumont-Guillemet with Placke's mistress's address, and the F agent more than once came close to killing the SD one; luckily for Placke, he spent most of the late spring away in Lorraine, out of Dumont-Guillemet's range.⁶⁰

A smaller F circuit was also at work in Paris: WIZARD whose organizer was France Antelme's friend Savy. Savy arrived by Lysander on 2 March near Châteauroux, received by GREYHOUND and accompanied by Jacqueline Nearne's sister Eileen (*Rose*) as his wireless operator. Antelme's arrest disrupted Savy's plans for pursuing supply and financial contacts; seeking to make himself useful nevertheless, he stumbled accidentally on a piece of intelligence so important that he came back to England by Lysander to report it, leaving at work in Paris both Miss Nearne and a second operator, G. Maury (another *Arnaud*), dropped to him four nights before. (The two operators attached themselves to SPIRITUALIST, who could use them.) Savy's information was about a large secret ammunition dump in the stone quarries at St Leu d'Esserent, near Creil. He discovered precise details of its siting and, more important, of its content: 2,000 V1 rockets, ready to fire. Bomber command stove it in early in July.⁶¹

From the point of view of the north-eastern railway network, Mulsant's MINISTER was a more important circuit than WIZARD; it rivalled SPIRITUALIST.

Mulsant dropped on 3/4 March, with Barrett another friend of Cowburn's as his wireless operator; together they tackled the Seine-et-Marne department close east and south-east of Paris. VAR brought them Mme Fontaine as a courier in March and five arms drops brought them nearly sixty containers in April and May. As well as looking after their chosen area between Meaux and Provins, they received two other parties: BEGGAR, three American subalterns called Bassett, Beugnon, and Martin who worked north of Paris round Creil and Senlis (dropped on 17 April), and DIETICIAN, the lone saboteur J. L. de Ganay (dropped on 10 May), who occupied himself with disrupting railway and canal traffic near Nangis and looking out for recruits to help him do more of the same after D-day. He was 'as nice a boy as one could hope to meet';⁶² this hardly qualified him for such dangerous work, but he stood up well to the strains he met in the field.

Dupont's DIPLOMAT, in the Aube – the next department to the east – came out of hibernation in the spring, and by the end of April had trained and equipped a hundred men to isolate Troyes, by road and rail, on D-day. Watt, who had been FARRIER'S wireless operator, was sent back to France almost as soon as the *affaire Toinot* had brought him to London. VAR took him across the Channel on 12 April, and he soon took over DIPLOMAT'S wireless work from Barrett, who had been transmitting for Dupont for the past six weeks and had handled some FARRIER traffic as well; an illustration of how short F agents could still be of sound and swift means of communication with England.

Fragar's DONKEYMAN had hibernated also, while the organizer was in England. The activity he could revive in it when he returned by sea at the end of February was severely limited by his choice of immediate subordinates: Roger Bardet and Bardet's friend J. L. Kieffer continued to work for the Germans. Kieffer had charge of Frager's Norman groups, and rendered them innocuous. (He still did not confine his activities to F section. Marcel Baudot, promoted county resistance leader of the FFI in the Eure in May by the arrest of the DMR, was shown by Kieffer a sizeable dump of parachuted arms hidden in a forest; said he could collect them at once; and found they had been spirited away when he called for them next day.⁶³) Frager himself lived in Paris, trying ineffectually to get a new sub-circuit started by remote control on the Riviera and engaging in the incessant conversations that represented, for many Parisians, the sum of their resistance activity. Bardet by now was beginning to reinsure with the allies; he lived in the farther parts of the Yonne, *en maquis*, where on 6 May he was joined by parachute by Bouchard (*Noel*) a competent wireless operator and Peggy Knight (*Nicole*), a twenty-one-year-old shorthand typist from Walthamstow who engaged in courier work after less than a fortnight's training. She was naive, modest, efficient, and self-effacing; her French was good; everyone liked her and no one noticed her.⁶⁴ She was quite out of her depth in the personal and political intrigues that riddled DONKEYMAN; though she was shrewd enough to

observe that Bardet 'looked to me like a hunted man very often, he never smiled, had big lines under his eyes and always looked as if he had something on his mind'.⁶⁵

Farther east things were going better for F section, ARCHDEACON apart. Though Rée himself was still out of action in Switzerland, STOCKBROKER kept plugging along quietly with its sabotage tasks under the direction of the competent sub-agents he had left behind him. One of these, Eric Cauchi (*Pedro*), had been parachuted in August 1943; he did useful work receiving and distributing stores, but was shot by the Gestapo in a café brawl on 6 February. To replace him, London sent out TREASURER on 11 April: the Comte de Brouville (*Albert* or *Théodule*), who had escaped to England with Griffiths in 1943 after several resistance adventures near Annecy. Poitras (*Paul*), a violet-eyed American naval wireless operator whom women found irresistible,⁶⁶ joined him – also by parachute – three weeks later. George Millar (*Emile*), who dropped on 1/2 June to form CHANCELLOR beside them to the north of Besançon, has given so lifelike an account of the circuit they had already built up that it would be impertinent to do more than refer the reader to it⁶⁷ before pressing on with the chronicle. The SACRISTAN team on a second tour, Floege and Bouchardon, also dropped into the Doubs, on 5/6 May, to reinforce STOCKBROKER and take over from it (Rée returned through Spain in time to play a useful part on EMFFI staff). Sarrette's GONDOLIER had meanwhile been developing other friendships of Rée's a long way to the west, round Nevers on the upper Loire. K. Y. M. Mackenzie arrived at the end of March, by a roundabout route through DETECTIVE in the far south, to send Sarrette's wireless messages; the two of them had 1,300 maquisards available by the end of May, as good as any in the district though still only lightly armed.

Another figure in the Nièvre calls for notice: Virginia Hall, the principal heroine of the early days, who had had herself taught morse privately to make the section take her back as a wireless operator when they would not use her as a courier.⁶⁸ On this second mission (SAINT) she took a wireless set with her, arriving by Lysander near Châteauroux with her old friend Denis Rake the FREELANCE wireless operator; her mission was to visit such maquis as she could find, anywhere she chose between Clermont-Ferrand and Nevers, and to see what sort of sabotage work she could get going.

This was a small, useful mission; away on the Swiss border MARKSMAN'S large useful mission was at work in conditions of a good deal of drama.

By this time the administrative cares of the maquis were beginning to weigh on SOE as well as the French. Not much could be done about food; the air lift for more warlike stores was all too small. But on the medical side some progress was possible: a few of the largest maquis were sent RAMC majors who had worked already in rough and dangerous conditions and were ready for more. Their presence probably did as much good to morale as their activities; these were often effective, and a number of things they

did were striking. One will long be remembered in the neighbourhood for leading a counter-attack, revolver in hand, through the gardens of the château where his team had been surprised in the middle of the night; he was wearing only a monocle. Another, Geoffrey Parker, who also took a liberal view of his Hippocratic oath, having seen what the Germans did to some of his wounded he had been unable to remove from their path, took on as a side-line the smuggling of £100,000 worth of what he believed were special gunsights for the RAF. In fact they were Swiss watches on their way to China to help a quite different SOE agent help SOE secure its postwar cash surplus. This task involved Parker in a pair of illegal frontier crossings through barbed wire by night. Once, when he was obeying his organizer's orders among a group of maquisards dispersing through some woods, he happened upon a seated German machine-gunner who opened fire on him at fifteen yards' range. The doctor, a burly man, nipped behind a much too small tree; and had the patience to wait till the German had run to the end of his belt of ammunition, and then the dexterity to aim his revolver half a second the sooner.⁶⁹

It may be noticed, a little ahead of time – a Dakota did not bring him till early July – that Parker (*Parsifal*) set up a fifty-bed hospital in a school at Yonnax west of Geneva, and proposed to expand it sixfold; shortly of course it had to be evacuated in a hurry, but he had assembled so enthusiastic and competent a staff that after a few days' flurry he could set it up again in a deserted barn in the Jura mountains.

Life in the Ain and Haute Savoie had been harsher in the spring. Early in February Vichy sent a force of about 4,500 miliciens and GMR into the departments, who stayed for two months and secured over a thousand arrests; but the maquisards were strong enough to drive them out, leaving it to the Germans to take over – if they could.⁷⁰ In a trial of strength in March, the Germans did succeed in conquering the Glières plateau near Annecy, where a maquis 700 strong – formed the year before by Tom Morel⁷¹, with some assistance from Peter Churchill whose initiative led to an arms drop in 1943 – had the superb foolhardiness to abide their attack instead of melting away. Heavy maquis casualties included fifty Spaniards who held out on an isolated hillock, quite literally to the last man and the last round; not one of the fifty was taken alive, and they had no ammunition left. This was magnificent, unforgettable; but tactically unsound. The Germans were only out for a few prestige gains – Paul Reynaud heard the attack was mounted as reprisal for the execution of some captured German agents in Morocco,⁷² and was meant to capture Heslop who of course took care not to be there at the time. It would have been wiser, though less heroic, to let the Germans possess themselves of that barren plateau and strike their blow in the air.

After the fighting, was over, reprisals were as bad as could be; some milicien prisoners the Germans had freed conducted them round the neighbouring

villages and pointed out the men who had spared their lives, so that the Germans could torture and shoot them.⁷³ Many more farms and some whole villages were burned down. This only strengthened the forces available to Heslop and Rosenthal, who had their area flexibly and carefully enough organized to be unaffected by the May arrests at the French regional resistance headquarters at Lyons; and between January and May they received nearly a thousand containers of arms.

Heslop's MARKSMAN area overlapped with Mesnard's DIRECTOR, but the two circuits were separate; nearly all Mesnard's communications with London were by courier and slow. Early in 1944 they dried up altogether; and SCHOLAR, was sent out in March, by parachute to the far south-west, to reinforce DIRECTOR and take the area in hand. SCHOLAR'S organizer was a young French nobleman, Gonzagues de St Geniès (*Lucien*), as brave and determined as he was patriotic; taken prisoner in 1940, he had secured his return to France by breaking his own arm with a hatchet,⁷⁴ and he had travelled on to England in 1943 specifically to be trained for his new task. A young Englishwoman, Yvonne Baseden (*Odette*),⁷⁵ went with him as his wireless operator. They found at once that Mesnard had been arrested in mid-January, leaving DIRECTOR'S affairs at a standstill; rapidly and securely the SCHOLAR team patched up the ragged holes and got a small new circuit onto its feet.

Near by, in the Lyonnais, there was more overlapping. Brooks's PIMENTO was busy in the railway yards, though it lost André Moch, killed in a skirmish with the milice in February. It nearly lost Brooks as well in May when a container full of grenades exploded on hitting the ground and alarmed a nearby SS unit, which promptly searched the dropping zone. The rest of the reception committee fled; Brooks himself shinned up a tree, where he remained hidden for a day and a night, making notes on the enemy's dispositions. Roger Caza (*Emanuel*) the Canadian wireless operator, dropped early in February, did useful work for him at the Toulouse end of the circuit, though the courier line still worked faster from Lyons. Robert Lyon's ACOLYTE, Marchand's NEWSAGENT, and Browne-Bartroli's DITCHER all had contact houses in Lyons as well as sabotage groups under training in the country. Each of the three was sent a reinforcement in the spring. Henri Borosh, who had already worked one spell in Burgundy as a wireless operator for VIC, organized SILVERSMITH alongside ACOLYTE with some distinction in the lower Saône valley. Regnier, formerly Marchand's assistant when both were working in SPRUCE, organized MASON alongside NEWSAGENT in and round Lyons itself. But Browne-Bartroli's newcomer Lesage (*Cosmo*), the elderly organizer of LACKEY, got on less well. He went to France on 8/9 February, by the Lysander that brought the Déricourts to England; Beauregard, a Canadian wireless operator half his age, was with him. Their mission was to reinforce DITCHER. But Lesage turned out to have made enemies rather than friends during his earlier work in Lyons, back in Duboudin's day; none

of his former colleagues were ready to co-operate with him, and LACKEY suffered from so many taxying accidents that it never got off the ground as a working circuit at all. Lesage retired in dudgeon to the country; Beauregard was caught by direction-finding in July, and executed in Montluc prison at Lyons just before the Germans withdrew.

The other circuits thereabouts, though sometimes hard pressed, managed to keep out of the Germans' way; and of course ARMADA'S part in RATWEEK helped directly to lighten the pressure on them. RATWEEK was shortly followed by a counter-attack near the area where it had had most success in France: the Germans tried to stamp out SOE'S organizations eastward of the Rhône. The result of their offensive illustrated again what the fate of PROSPER and its companion circuits had revealed in Paris: perpetual vigilance was the price of safety. MONK, the smallest of F'S three remaining circuits in the lower Rhône valley and on the Riviera, was shattered; but the specialised PIMENTO railwaymen's groups and the widespread JOCKEY circuit were saved by their previous division into small packets, ignorant of each others' existence and without either the means or the inclination to betray the channels by which arms and orders reached them. JOCKEY even survived a sharper peril, about the worst that such a body could endure: a strong attempt to force its second-in-command to betray Cammaerts its organizer to the enemy.

The exact circumstances that led to MONK'S end are still obscure, and are likely to remain so. Skepper, Steele, and Eliane Plewman had got themselves reasonably well organized in and round Marseilles; and their circuit was none the less effective for being small. The evidence collected by Elizabeth Nicholas shows that Steele at least, hidden as a *réfractaire* in a villa above St Raphael, did not have too dreary a winter, and the others could sometimes visit him.⁷⁶ In January they blocked the main line to Toulon by a derailment in one of the tunnels near Cassis, nine or ten miles east of Marseilles, and managed to destroy the first breakdown train that came to clear the wreck; this kept the line closed for four days. In the first fortnight of the new year they put thirty locomotives out of action, and they damaged thirty more in the middle of March, as the sands of their luck were running out. For Skepper and a local helper, Julien Villevielle, were arrested after a struggle at Skepper's flat on about 23 March; and Steele and Mrs Plewman – possibly attempting a rescue, probably calling by previous appointment – were caught in the mousetrap the Germans laid there next day. Mme Régis, in whose villa Steele had been living, held that the fatal denunciation came from a Frenchman, who was tracked down and executed by the French after the war;⁷⁷ his trial fortunately clears the reputation of another unlucky SOE agent, Jack Sinclair, on whom suspicion would otherwise have fallen. For this twenty-two-year-old subaltern, dropped to MONK on 6/7 March from Algiers as an assistant, got mixed up by a horrible staff muddle with an OSS radio game, and was taken by his reception committee straight to prison.

None of the arrested MONK agents and sub-agents – the mousetrap caught about a dozen in all – said a word, though all of them but Sinclair were interrogated severely; Mme Régis and the other survivors were able to go into hiding. But the circuit was completely *brûlé*, no more work could be done by it. The inquisitive historian is bound to ask why, in that case, another million francs were dropped to it – 500,000 each by the May and the June moon.⁷⁸ There is one fragment of evidence, from outside SOE altogether, that the Germans were playing Steele's set back to London in April.⁷⁹ No other light is thrown by the surviving files in London; but it may be that on the Mediterranean coast F section was able to repeat at lower cost its achievement in south Normandy, and use some drops of stores and money to a circuit known to be defunct to deflect the Gestapo's attention from two lively bodies, JOCKEY and GARDENER, which next deserve description.

JOCKEY, under a similar strain, did better than MONK, because it had been more carefully organized with such mousetraps in mind. Even Cammaerts' meticulous recruiting system was not absolutely foolproof, and a sub-sub-agent recruited too hurriedly talked too much. This was a thoughtless girl at Cannes, who could not resist boasting to one or two old friends that she had new friends of importance. In Cannes the Gestapo had a powerful organization, and her indiscretion was carefully followed up; about thirty arrests resulted, including Agapov the second-in-command of the circuit, who happened to be in Cannes at the time (4 April). All the trouble Cammaerts had taken over security now brought its reward. Hardly anyone outside Cannes was arrested, because none of the local people knew how to get in touch with the rest of the circuit – they had to wait for couriers or messages to come to them; nor could Agapov, who did range far outside the Riviera, offer any means of finding Cammaerts his close friend, because Cammaerts always took care to keep even from him the constantly varying secret of his own address. A full personal description of Cammaerts was circulated all over southern France; no one succeeded in detecting or betraying him. The Germans offered Agapov what they had apparently offered to two other prominent figures in big F circuits – Gilbert Norman and Grandclément: immunity for his friends' lives if he would betray them. This time they were unsuccessful, for there was no means by which anybody but Cammaerts himself could betray the bulk of his agents, since they were unknown to each other. The Gestapo did catch Janyk, the assistant wireless operator, Martinot the American sabotage instructor, and Latour the Lysander expert, all of whom like Agapov survived their concentration camps; but Cammaerts himself they could not catch. With the help of Raynaud, Floiras, and Sereni (*Casimir*) a replacement for Janyk dropped from Algiers on 11 May, he kept JOCKEY in smooth working order and went on distributing arms.

Another exceptionally secure circuit was working close by JOCKEY: GARDENER at Marseilles. This was run by Boiteux, formerly the head of SPRUCE, who was dropped on 6 March with Cohen (once of JUGGLER) to

work his wireless and Aptaker as his assistant. They arrived too late for useful touch with Skepper, whom they had been meant to reinforce; Boiteux replaced him instead. He was younger, tougher, and more adroit, and sank himself without effort into the marseillais underworld; whence he will emerge next chapter.

The Camargue remained empty of F agents after Mesnard's circuit broke up; and west of it, in the Hérault, were only a few small PIMENTO teams of cheminots. West again, in the Aude and southern Tarn, Sevenet developed DETECTIVE round Carcassonne into an efficient body of transport saboteurs, and armed the thousand-strong CORPS FRANC DE LA MONTAGNE NOIRE.⁸⁰ And in Gascony, George Starr's WHEELWRIGHT was now flourishing securely. He had several hidden *Eurekas* and reception committees well trained in their use. His stocks of arms and explosives and the numbers of men he had trained to use them mounted steadily; in these five months, from 105 sorties, he got over 1,200 containers, substantially more than PROSPER or SCIENTIST in the days of their glory, and more safely stowed. Moreover he could call on an exceptional degree of local support, deriving from an ancient tradition in that part of France of hostility to the central government, whatever it was. Two and three generations earlier, Jaurès the great socialist and Gambetta the great radical had appealed to this tradition with success; its origins lay much further back in French history, behind the eighteenth-century revolt of the camisards,⁸¹ in the days of the crusades against the Albigenses, or of the English occupation, or further back still in almost forgotten tribal quarrels, like those that still make Wiltshire men and Gloucestershire men suspect each other. Starr kept up his escape line contacts, and was able to speed on their way nearly fifty escapers, including some important agents, who broke out of the French concentration camp at Eysses near Toulouse on 3 January. Hudson of HEADMASTER commanded this party; Philippe de Vomécourt who also belonged to it has written an exciting account of how they managed to get away.⁸² Passing them through WHEELWRIGHT'S area to the Pyrenees was one of the first tasks of Starr's new assistant Claude Arnault, who arrived next night by parachute with Anne-Marie Walters (*Colette*), Starr's courier, who also helped in this tricky and delicate task.⁸³ Rechenmann returned by sea on 21 March to gather his friends round Tarbes together into a more formal circuit, called ROVER, to be run on the lines he had learned at Beaulieu; and this time they made a decisive impact on several Tarbes factories,⁸⁴ though their leader had the ill-fortune to be arrested at the end of May and removed to Germany, whence he did not return. Sirois (*Gustave*) his wireless operator, still at large, joined up with CARVER which is about to be described. De Gunzbourg meanwhile kept WHEELWRIGHT'S outlier round Bergerac in being, despite German attempts to break it.⁸⁵

Downstream from Bergerac, the Gironde estuary was being-opened up again this spring. Corbin, de Baissac's friend from the Vichy police force, had by now like Rechenmann been trained by SOE, and was daring enough

to return to the edge of the area where he had been well known; parachuted late in April, he set up the CARVER circuit between Angoulême and the coast by Rochefort. Roger Landes, braver still, went back in early March to Bordeaux itself (jumping with Sirois on the 2/3rd), to establish ACTOR on such ruins of SCIENTIST as still seemed to him capable of bearing the weight of a circuit. Grandclément was still very much alive, and still trying to spread round the bordelais resisters the anti-communist doctrines the Germans had instilled in him, so that Landes had to take care to keep out of his way. Yet with care and trouble, in complete clandestinity, he was able to save a great deal from the wreck of the previous autumn. Those that were distressed were taken by the Gestapo, and those that were discontented or bitter of soul had retired into Grandclément's cave of Adullam;⁸⁶ but many plain and gallant Frenchmen knew that France's enemy in 1944 was Germany and that their duty was to resist. Landes, working his own wireless sets from several different places, approaching people through cut-outs whenever he could, checking and counter-checking every move, managed to get over two thousand armed men organized and set their tasks by D-day. When de Gaulle's DMR Gaillard (*Triangle*)⁸⁷ reached Bordeaux in May, he found that Landes had already got the area so well in hand that there was hardly anyone outside ACTOR'S zone of influence for RF to recruit; and the two practically joined forces, much to the advantage of local resistance though rather to the annoyance of Gaillard's commanders in Algiers.

With AUTHOR, the Corrèze offshoot of the old SCIENTIST circuit, Landes had no dealings; this was as well. For Peulevé by a maddening piece of bad luck was caught at his set (with Roland Malraux) at a house near Brive on 21 March; erroneously denounced by a neighbour, who had noticed some comings and goings of strangers, as a black marketeer. His arrest brought a lot of trouble to the Germans, recorded elsewhere,⁸⁸ and little to his circuit; for Jacques Poirier (*Nestor*) his still younger assistant – after whom the group was renamed DIGGER – simply took it on and ran it himself on the lines Peulevé had already trained him to follow. Poirier was so secure that it was not till after the liberation that the circuit discovered that the sub-agent was his own father, who had regularly supplied him with intelligence about German doings in the department. Beauclerk (*Casimir*)⁸⁹ and Peter Lake (*Basil*) came in by parachute on 9 April to assist him.

FOOTMAN, DIGGER'S neighbour in the Lot, was equally secure and even more successful. George Hiller (*Maxime*), an English officer still under thirty with a cold-blooded temperament and (as it turned out) almost uncanny gifts as a diplomat, was dropped on 7 January with Watney (*Eustache*) his wireless operator. They were greeted almost the night they arrived by a foreman from the Ratier propeller works at Figeac, which was turning out variable pitch propellers for the Luftwaffe at the rate of 300 a week. Hiller had only to approve the foreman's plan and make up and fuse a few small charges; and before the end of the month this hitherto energetic armaments factory

was out of action. The destruction of half-a-dozen essential, temporarily irreplaceable machine tools deprived the Germans of any more propellers from this works.⁹⁰

This was as important a piece of industrial sabotage as F section did anywhere; but it was incidental to Hiller's main task, which was more political than military. He had to find the elusive Colonel *Véni* (Vincent), a socialist with a following in the south – mainly marseillais⁹¹ – some thousands strong, and enlist him on the allied side if he could. This group had originated in the *Service Froment*, the early socialist intelligence *réseau*,⁹² but had split away from it; no one in London understood that the split had been made on purpose, and that the GROUPE VENI – renamed FRANCE AU COMBAT – in fact represented the military wing, in the former ZNO, of the French socialist party, the SFIO.⁹³ It was even unknown in London whether Vincent's paramilitary squads were going to fight for the gaullists, or for the communists, or not fight at all, and though they were known to be at least partly trained it was not known how far they were armed. Hiller was able to meet Vincent, to form an idea of the size and reliability of his groups (several thousand, and probably sound, respectively), and to secure a dozen arms drops for them. Vincent, having received the arms, later told Hiller he would join the communists after all, and help them to seize power; and Hiller by plain force of personality persuaded him to fight in the common allied interest instead. But the persuasion took time to take effect; so FOOTMAN'S parties only played a slight part in one of the main achievements of resistance, the delay imposed on 2 SS Panzer Division that the next chapter will describe.

FIREMAN, on the other or northern side of DIGGER, had less astonishing feats to its credit; it was a plain competent working-circuit nevertheless, also dealing with *Véni's* followers, run in the neighbourhood of Limoges by the Mayer brothers, P. E. and E. P., Mauritians by origin like several of F section's most vigorous agents and unrelated to Daniel Mayer the distinguished French socialist resister.⁹⁴ They arrived by parachute on 7/8 March, and Paddy O'Sullivan the partly-trained but enthusiastic Irish girl who was to work their wireless came a fortnight later. All of them dropped, like several other circuit leaders and reinforcements, to receptions arranged by Southgate's STATIONER. By a questionable series of decisions, F section's staff went on pouring agents into France through this one channel. As many as sixteen agents were sent in April and May to receptions by STATIONER and its successors. To F's superiors in SOE this should have appeared a grave risk; for it was precisely through this method of continuing to pass agents into occupied territory through one channel that the Abwehr in Holland had been able to receive so large a proportion of N section's agents.⁹⁵ Yet SOE was so divided into self-contained groups, insulated from one another, that nobody in F section had yet heard of the troubles in Holland.⁹⁶ Buckmaster in any case preferred to work to people he knew well, and knew to be good, and in this case he

had chosen soundly. His best justification is success; none of these drops went awry – an ironic contrast with several more carefully prepared ones a month or two before. That there were no tragedies was due to the tenacity of one man: Southgate himself. For as the reader may remember Southgate once – once – put a foot badly wrong, and hurried on May Day to call on an assistant wireless operator at Montluçon without pausing to see whether the danger signal at the operator's lodgings was flying. It was; the Germans caught him straight away and identified him shortly. Their identification was confirmed at the Avenue Foch by his old school friend John Starr, who greeted him at sight by his right name. Southgate kept his head and refused to talk, then or later.

His circuit was in good hands; for Amédée Maingard and Pearl Witherington split it between them and carried on. She concentrated on the northern half of the Indre, in the Valençay-Issoudun-Châteauroux triangle where F section's career in France had begun. The position of a woman, a foreigner at that, as a circuit commander was perhaps a trifle invidious; she was not the sort to be put off by a point of etiquette. Her ancestor Richard Witherington had been so bonny a fighter that at the battle of Chevy Chase 'when both his legs were hewen in two Yet he kneeled and fought on his knee.' She was as tough as he had been; her fiancé (later her husband) Henri Cornioley was with her;⁹⁷ she found a complaisant local colonel to mouth the orders she composed, and her WRESTLER circuit settled down to cut the main line from Paris to Bordeaux and keep it cut. Widespread German placards bearing her photograph and offering a million francs for her person had no effect on her safety; she had good friends.⁹⁸ Maingard's SHIPWRIGHT looked after the area southeast of her and north-east of FIREMAN with equally unostentatious efficiency. Southgate's arrest in fact brought the Germans only slight advantage; and his achievements both before and after it so much impressed Baker Street that – rare distinction – he was gazetted DSO while in an enemy concentration camp.⁹⁹

Though SHIPWRIGHT and WRESTLER were sound enough themselves, they could not save LABOURER, a circuit as unlucky as LACKEY in trying to reach take-off point. Leccia, Allard, and the Belgian Geelen – an old hanger-on of *Prospers* – arrived by parachute on 5 April, landing down in the Creuse and delivering to a safe-house near by – a country café – a large sum of money of which STATIONER was in immediate need; Pearl Witherington had much trouble in extracting this, as none of the passwords she knew were known to the safe house, where she was suspect as a stranger anyhow. LABOURER, whose members already knew each other well, was started up among Leccia's friends and relations in Touraine and Paris; but one of these turned out to be working with the Germans, and all three agents were soon arrested. Southgate had just sent them a courier, Odette Wilen, who had been parachuted to him as a wireless operator but had only been partly trained for that task. She very narrowly avoided arrest with her new

companions; tried, with Virginia Hall's help, to rescue them, but without avail; and eventually crossed the Pyrenees.¹⁰⁰

These are the last arrests this chapter has to record; F's other parties, in the Loire valley and in Brittany and Normandy – three of the four critical areas for OVERLORD – were all safe, though one of them, SALESMAN, had a very narrow squeak. Liewer parachuted into France early in April to find out what had in fact become of his friends round Rouen;¹⁰¹ he took with him Violette Szabo, the daughter of a lorry driver, who was one of the best shots and the fieriest characters in SOE.¹⁰² They at once found Rouen dangerously full of inquisitive Germans; almost all Liewer's friends seemed to have vanished, and his courier tore off a wall a description of himself setting a price on his head. A Lysander brought them back to England after three weeks' reconnaissance.

As the last chapter showed, Hudson and de Baissac were much more successful with their revived HEADMASTER and SCIENTIST circuits, and Henquet of HERMIT also joined de Baissac in south Normandy late in May; his working area was to lie between Chartres and Blois, old PROSPER country but with new and more fortunate friends. Robert Benoist, Grover-Williams's colleague earlier in CHESTNUT, was sent back to France a month after his February escape by Hudson, to have another try at CLERGYMAN, a circuit round Nantes.¹⁰³ With him went Denise Bloch as his wireless operator. They prepared their set targets and then went up to the Benoist estates close south-west of Paris, where there were still CHESTNUT arms dumps and CHESTNUT fighting men such as Wimille hidden away. Benoist soon had a circuit running again there and claimed he could raise 2,000 men in the forest of Rambouillet.

One odd man out needs recording. Rouneau, the Belgian organizer of RACKETEER, was sent to Brittany rather hurriedly by sea in April – when the disaster to the BRICKLAYER party was known¹⁰⁴ – to take up where PARSON had stopped, and get something going in that peninsula. This was a difficult area for F to work; partly because other secret services wanted to monopolise it – hundreds of escaping aircrew passed that way; partly because DF did not enjoy having his VAR line put out of order by the extra police vigilance that an active F circuit might induce; partly because it was a busy area for FTP maquis whose leaders would be likely to be out of sympathy with the British.¹⁰⁵ A further difficulty for Rouneau was that LABOURER's disappearance left him with no nearer wireless contact than his old friends in WHEELWRIGHT at the other end of France. He was still busy trying to organize groups round Rennes when D-day came.

Lastly, an old stalwart, Philippe de Vomécourt. After a successful escape journey and a very little training and briefing – he still thought, with some justice, his experiences entitled him to teach rather than to learn – he returned to France by Lysander on 16/17 April. His new VENTRILOQUIST was severely cut down in size from the old vast empire that had covered almost the whole ZNO; he was to work in the western Sologne, in the triangle

Orleans-Vierzon-Blois, across the Cher from what became WRESTLER'S area. Much of what he did – and he did a lot – is set out with his usual force and vivacity in his book;¹⁰⁶ as is the pathetic tale of Muriel Byck his wireless operator, who suddenly collapsed and died of meningitis. He went to her funeral, and only evaded the Gestapo who had come to seek him there by slipping over the wall at the back of the graveyard and going into hiding.¹⁰⁷

Two more agents were waiting to leave for eastern France at the end of May – Guiraud, bound for the Haute Marne as GLOVER, and George Millar of CHANCELLOR. Both left on 1/2 June.

This somewhat lengthy survey has shown how far Buckmaster had packed his organizers into France, to carry out the harassing tasks SHAEF called for on D-day and to prepare the secret army that would help the expeditionary force to throw the Germans out. But before we can tackle the expedition, there is one more staff hurdle to cross.

The section's London staff was a good deal exercised by the question of what treatment the gaullists were likely to mete out to F's agents who were also French citizens, in the by now probable event that an allied victory provided the occasion for a gaullist republic to come to power. It was Cammaerts who brought the point up originally, when visiting England at the turn of the year; it caused a good deal of anxiety, both in F section and higher up in SOE; and it was taken up through the Foreign Office with the gaullist authorities in London and Algiers. They maintained the doctrine that it was unconstitutional for French citizens to serve in the armies of a foreign power with a curious legal rigour; curious because their own status was in the eyes of a constitutional lawyer no more legal than that of the Vichy regime. But the fact of their hostility was plain, and it took time, tact, and trouble to persuade them to relax. There was some unnecessary pother about this, caused by the over-zealousness of a junior staff officer in Buckmaster's section, who handed over a copy of a worried paper on the subject by Morel to a back-bench MP. The MP sent it direct to the Foreign Secretary; long refused to believe the Foreign Office's assurances that negotiations on this very point were in train; and was affronted when the informant was dismissed for acting in breach of the official secrets act and the MP was reminded that the act applied to members as well. The Foreign Office file shows that a good deal of care was lavished on this case by several weary officials, acting for Eden who minuted at an early stage 'I have troubles enough already'. Negotiations dragged on long after D-day, when F section was reduced to a rear link under Vera Atkins and its staff were submerged in the day-to-day telephone and teleprinter chaos of EMFFI. In the end a handsome settlement was reached; Gubbins was able to report on 19 September to the weekly SOE-FO committee meeting that Koenig had agreed to grant an equivalent rank in the French army to French officers who had received British commissions through SOE.¹⁰⁸ This proposal was accepted, and the French kept their word. It is time to pass to more important business. For the whole

dispute was as unreal, and basically as unimportant, as the rivalry between F and RF sections. French citizens in each section *avaient bien mérité de leur patrie*, and had done their best according to their lights and their opportunities; a Pierre de Vomécourt as much as a Pierre Brossolette, with their splendid failures; a Dumont-Guillemet as much as a Deshayes, with their successes.

XII

A Run of Successes: June to September 1944

‘We did not ask why; we only knew this was what we must do. Let the historians seek more complex motivations if they wish, but they will not destroy the simple truth as we saw it.’

Philippe de Vomécourt¹

As we saw at the beginning,² soon after OVERLORD was launched on 6 June 1944, the *Etat-major des Forces Françaises de l’Intérieur* (EMFFI) was set up to undertake the direction of all active forces of resistance in France that had previously been working either with F or with RF section; and the staffs of both sections and the staff of BRAL were thrown together in the one headquarters of external resistance under General Koenig. Many of this staff turned out incompetent for their work. Though Koenig’s executive chief of staff, Colonel Ziegler (*Vernon*), worked tremendously hard, he had more to do than it was humanly possible to get done, even with the help of Gubbins’s chief of staff, the highly skilled Barry, who had charge of the operations section. The main troubles were four: the staff had to start work at full speed, with no time to shake down together; a fair proportion of them were quite inexperienced in this specialised field; many of the others had, till the day before they joined, regarded some of their colleagues in EMFFI with suspicious rivalry; and many of the French were so deeply concerned with the political future of France that they found it hard to concentrate on their unfamiliar daily tasks. Hutchison felt at the time, from the field, that London’s pulse was beating feebly; and Thackthwaite was greeted, wherever he went in France in the autumn, with the inquiry ‘What went wrong at the end of June?’³ The leading people in the intelligence, operations, and special missions sections (known, to suit the French, as the 2^e, 3^e, and 6^e bureaux respectively) were experienced GSOIs and III’s from F, RF, and AL sections and from BRAL; even so, agents were now and then sent to the wrong places, and many requests for fighting stores from the field went unanswered.

But in order to set EMFFI up it was of course indispensable to get de Gaulle’s consent; and, a still more urgent and more awkward problem, his consent had to be got for the use of troops in his army who were to take

part in the actual invasion. The last of the frightened security pigeons let loose by MENACE, the ill-fated attack on Dakar nearly four years before, came home to roost on the night of 5/6 June. Right through to the moment of the Normandy landing, the British stuck to the lesson they reckoned they had learnt from MENACE: never impart an important secret to the French till you have to. By the time de Gaulle was summoned into Churchill's presence late on the evening of the 4th to have it broken to him that operation NEPTUNE was actually taking place on the following night⁴ and to be asked whether he minded if a French commando troop and a small party of French SAS took part in it, the commandos were already at sea and the SAS troops were briefed and sealed on a Gloucestershire airfield. Faced thus abruptly with the choice of allowing his own troops to fight on a plan he had never seen, or of being altogether excluded from the allied liberation of his own country, de Gaulle of course gave way and gave his consent. But he did it with a bad grace, and followed it up by a sharp quarrel with Churchill. Churchill, equally overwrought, was almost as extreme in reply. Both these great men spent the first day of the invasion in a mood that each probably wished he had left behind him many years before; Churchill forgot his own maxim that 'There is no room in war for pique, spite, or rancour.'⁵

The French SAS party is claimed by Robert Aron as the very first element of the invasion force to set foot on the soil of France.⁶ They were in fact beaten to it by about a quarter of an hour by two minute British parties of the 1st SAS regiment – an officer and four men in each – who were dropped near Jumièges and near Isigny, at the south-eastern corner of the Cherbourg peninsula, as a small element in FORTITUDE, the deception plan which encouraged the Germans to believe that NEPTUNE was only a feint and that the main landing was to come in between the Somme and Boulogne. The main armament of these two parties (TITANIC) consisted of Very pistols and gramophones; the gramophones played suitable records of small arms fire interspersed with soldiers' oaths, while the Very pistols lit the sky for miles round the dropping zones. Hundreds of dummies went down with the few parachutists, and they helped to confuse further the German coastal reserves, already confused enough by the American airborne landing a little farther west, which was far more scattered than had been planned. This was just the sort of task that SOE had expected in its early days to be allowed to perform itself, but the more secret force had not succeeded in establishing itself as trustworthy enough in the eyes of the deception planning staffs. SAS was not much trusted either; two other TITANIC parties farther afield were cancelled at the last moment.⁷

For once, a fairly exact assessment can be made of the value of a small operation behind the lines: the slight effort involved in TITANIC produced a disproportionately vast effect. Of all the D-day landings the most difficult turned out to be the one on OMAHA beach, between Port-en-Bessin and the mouth of the Vire. The German 915th infantry regiment, the reserve

brigade of the division holding this sector, was dispatched at 3 a.m. to counter an airborne threat near Isigny,⁸ and wasted the entire forenoon of 6 June in pursuing TITANIC'S spectral airborne army and a few American stragglers. Consequently, the American seaborne forces just managed to establish themselves ashore at OMAHA; and when the 915th regiment made its belated counterattack in the afternoon they could not quite be dislodged.

At the moment of the invasion there was a great deal of other work that SOE had been allowed to undertake; and practically all of it was carried through with success. Eisenhower and Tedder had relied on the allied air forces as their principal weapon for preventing German reinforcements, and while they hoped for further support from resistance movements at work on roads and railway lines, they regarded this further support – in the catch phrase of the time – as a bonus, which could be enjoyed but was not to be relied on. As it turned out the bonus from resistance was of a size and importance comparable with the air forces' achievement; and its successes raise several interesting questions about the value of bombing forces in the closing stages of pre-nuclear war. For at last, with the allied re-entry en masse into France, the years of patient assiduity produced what Churchill and de Gaulle, Gubbins and Koenig, Dewavrin and Buckmaster, all the scores of agents already dead, all the hundreds of agents still alive – in prison or out of it – had been striving to achieve: a French national uprising. The British have often been accused of having triggered off this uprising incautiously, displaying a mythical readiness to 'fight to the last Frenchman' and hoping that pressure could be taken off the Normandy battlefield by a thousand hopeless ventures far behind the lines. Of course this was not what either the British or the Americans sought; and only the insensate partisans of the extreme French right and left desired any kind of total upheaval. The planning staffs of SOE/SO had worked out, in close co-operation with the planning staffs of COSSAC, later SHAEF, an elaborate phasing system for calling the hidden forces of armed resistance out into active guerilla province by province. At the last moment, the phasing system was scrapped, on SHAEF's orders: it was judged indispensable to secure the maximum effort in France on the very night before D-day, to ensure the success of NEPTUNE on which all depended.⁹ The BBC sent out warning-messages on 1 June (as on 1 May); and hundreds of action messages went out at 9.15 on the evening of 5 June, when the van of the invasion fleet was almost in sight of the French shore.

We must interject here a singular instance of the dangers that these BBC messages carried with them. One of Philippe de Vomécourt's warning messages was *'les sanglots longs des violons d'automne'*; this told his VENTRILOQUIST railway cutting teams to stand by. It was followed on 5 June by the second half of the couplet – again slightly misquoted from Verlaine: *'bercent mon coeur d'une lagueur monotone'* which told them to act that night.¹⁰ Now this particular pair of VENTRILOQUIST messages had originally been allotted to BUTLER;¹¹ and it seems probable that the Germans had found the message out from one or

other of the members of the BUTLER circuit who had fallen into their hands months before; or even that the message had been, unintentionally, passed direct to the Germans over Rousset's captured set while they were working it back.¹² At all events the Germans did know about this pair of messages, though they misunderstood their application, and thought they represented a general call to railway resistance forces all over France. When the SD wireless section in the Avenue Foch heard the '*bercent mon coeur*' action message passing a few minutes before 9.30 on the evening of 5 June, they at once alerted the German high command in the west.¹³ In Rommel's absence – he was spending his wife's birthday at home – comparatively little notice seems to have been taken of this warning. Ellis records that the German 15th Army warned its corps, about an hour later, that intercepted code messages pointed to invasion within 48 hours; while the 7th Army, responsible for the bulk of the threatened assault area, took no action at all.¹⁴ They had been warned too often. The instance is a curious example at once of the efficiency and of the incompetence of the nazi fighting machine; with the unusual twist that the party side of it was in this instance more efficient than the military. But we must return to the main stream of BBC messages, which lasted on these two nights a trifle longer than usual.

All over France SOE's circuits activated by their messages were busy; or if like George Millar's newly-forming CHANCELLOR they had so lately been set up that they had not the means to do anything at once, their members were frantic with anxiety to find means and to get something done as soon as they could. The most efficient circuits went into action straight away that night: 950 out of 1,050 planned interruptions of the railways were made. PIMENTO closed all traffic on the line between Toulouse and Montauban – only one more northbound train passed through Montauban before it was liberated nearly three months later – and though the same circuit's teams could not quite shut down rail traffic in the Rhône valley entirely, at least they ensured that every single train leaving Marseilles for Lyons after D-day was derailed once at least in the course of its journey. JOCKEY's rail cutting teams were quite as efficient and quite as prompt as PIMENTO'S; so were DIPLOMAT'S round the important junction of Troyes; so were FARMER'S in the tangle of railways round Lille and Tourcoing, all of which they cut within a night or two after D-day and kept cut till the end of the month, with the explosives sent up to them by SPIRITUALIST. Some of the country circuits did even better: Pearl Witherington's WRESTLER and Maingard's SHIPWRIGHT claimed no fewer than eight hundred interruptions of railway lines in the single department of the Indre during the month of June. This was perhaps even too much zeal; but the main line from Paris through Châteauroux and Limoges to Toulouse does run across the middle of the Indre, and it was of extraordinary importance to the main battle in Normandy to keep that main line closed to German traffic, because there was an SS armoured division near Toulouse which was ordered to join in the Normandy fighting on D + 1.

We will come back to its adventures later. The point of immediate importance is that the news of the long-awaited invasion on the Norman coast combined almost everywhere with local news of some local resistance activity; for by this time SOE's tentacles reached into practically every part of France, and only along the eastern border, from Sedan through Metz to Strasbourg and Mulhouse, were SOE's forces weak or non-existent (the weakness was due partly to the tendency of some Alsatians to be pro-German, partly to the SD's deception of F over the ARCHDEACON circuit in Lorraine).¹⁵ The effect on the French of all this good news coming at once was that everybody not tarred too black with the brush of collaboration with the Germans was anxious to come forward and take part in resistance activities straight away. The whole elaborate phasing system for calling out resistance bit by bit was overtaken by the NEPTUNE emergency and then by the enthusiasm of the French: resistance in fact called itself out over much of the country. By mid-August, as will be shown, enough discipline had been re-established to produce useful close SOE support for DRAGOON; the support for OVERLORD was a good deal more general than the staff had planned as well as a good deal more effective than they had hoped, though it also brought many of the French casualties they dreaded.

As the insurrection grew, de Gaulle could say after the Italians of 1848, *Francia fara da se* – France would liberate herself. With the appearance, in country lanes and in the streets of small towns, of a secret army in being, casting its secrecy aside, the hardest part of SOE's work was done. Commanding this force was no job for foreigners; the remaining tasks were to provide ammunition, more arms, and advice.

SOE never attempted in France to do what the *Lehr-Regiment Brandenburg* did on the other side in Russia: operate tactical or even strategic reconnaissance and fighting patrols behind the lines in enemy uniform.¹⁶ This type of operation would have needed more care and skill in preparation than SOE's staff in 1944 were capable of devoting to it; it called also for detailed joint planning with front-line army formations, for precisely timed co-operation with them, and for much more widespread knowledge of the clandestine force's existence than any British secret service thought advisable. Moreover, the regular officers who commanded the British corps and divisions that would have been involved in this sort of work had all been trained in a tradition that distrusted irregular methods of war and indeed despised them. In fact the main cause of trouble was this: regular commanders of regular formations did not understand the weapon. D'Astier's tale of the obstructive Colonel de Chevigné at EMFFI¹⁷ illustrates the difficulty clearly; but it was by no means confined to the French, This is not the place to touch on the question whether the best brains in the American armed forces were available for Europe at all; but certainly in this theatre the conservatism natural to all high commanders¹⁸ was reinforced by extra conformist caution.

From the beginning of 1944, small SOE detachments had been set up at the headquarters of 21 Army Group and of the Canadian First and British Second Armies, to explain to the army operational staffs what resistance could and could not do; after D-day, Brook with advanced SFHQ was alongside SHAEF's advanced headquarters, for the same purpose. From then on, all four of these special force detachments were in constant wireless touch with SOE's main W/T base, and could exchange information through it with any SOE circuit in France. Occasionally they were able to transmit army commanders' orders for specific acts of sabotage or 'counter-scorching' (the preservation of objects the Germans might be expected to destroy); in this way, as with rail and telephone demolitions, a much larger bonus was received by the British armies than their staffs had anticipated.

With the major landing on the continent, SOE's major effort of supply began;¹⁹ so did the major influx of agents, the whole uniformed JEDBURGH effort, a swarm of *missions interalliées*; so did the participation of SAS troops, over 2,000 of whom operated behind or across the main fighting lines during the next three months, and of the American OGs who dropped in smaller numbers but with at least equal enthusiasm. To match the arriving agents, the mass of French opinion, long smouldering and flickering in resentment at the nazis, finally burst into a flame of anti-nazi activity. Activity of course implied peril; this was no news to SOE, but the French were not fully prepared for it. Among the hundreds of thousands of newcomers to the maquis the SD from its numerous offices scattered round France did manage to include a few double agents; and among the many areas where the maquis came down from the hills and showed themselves in the villages and country towns near their hiding places there were some ugly disasters.

The ugliest of these was in the Vercors, and SOE's part in it needs sketching. The EUCALYPTUS mission, decided on in May after the regional chiefs in Lyons had been arrested, did not finally leave Algiers until 28 June. The earlier warnings from Thackthwaite and Cammaerts that the Vercors needed artillery, particularly anti-tank artillery, were not heeded: the mission's object was laid down as arming the 2,500 less active Vercors maquisards with stens, rifles and grenades. A few heavy machine guns, and possibly some mortars, might be dropped later; but the *ordre de mission* included a comment that 'true guerilla tactics do not require the employment of heavy weapons'. The mission's members were to report on suitable dropping grounds, to help in training, and most important to urge on the local leaders 'not to accept more men than it will be possible to arm adequately'. Their orders included a warning 'that the Vercors is not given a high priority at the present time', and 'that it is your duty to advise the local leaders to undertake small operations aimed principally to interfere with the enemy communications ... avoid open fighting with the enemy'.²⁰

EUCALYPTUS was commanded by an English major, Desmond Longe,²¹ who took his friend Houseman with him. In peacetime Longe had been a

bank clerk, Houseman a land agent; both were rising thirty. They were close friends who had joined SOE together in 1941; Longe had since been active abroad and Houseman an STS instructor. They were supplied with false papers, and told to leave them in Algiers. Cover stories would have been useless as neither spoke French; and in any case they were dropped in uniform. Why the staff entrusted such a liaison mission to officers with so little knowledge of the language is obscure; probably London had not appreciated the importance of the Vercors. Moreover the tale of its undoubted sufferings has been exalted into a myth after the event.²² Two French speakers did go with them, an American signals subaltern, the bilingual Pecquet, who worked to London, and Croix, a Frenchman who worked to Algiers. Due to faulty MASSINGHAM packing they only had one usable set. Two more French officers, Conus (*Volume*), a distinguished marksman in his forties, and an operator called Pierre with another set, joined them a fortnight later. An OG fifteen strong dropped with the main EUCALYPTUS party on 28/29 June.

The mission got off to a bad start, with a series of misunderstandings with Cammaerts, who happened to be there when they arrived, and with Marten a young JEDBURGH major. Marten and Longe were almost equally inexperienced in France, and neither had been briefed on the other's role. It was as well that Marten was sent back to Algiers at once with some policy messages from Cammaerts. Cammaerts' difficulty was real: he had been made head of all allied missions in south-east France, but SOE failed either to tell him that EUCALYPTUS was coming, or to tell EUCALYPTUS who he was. Naturally he resented the arrival in one of his pet areas of a party of superficially incompetent newcomers. However, his enemies were the Germans, not the British. Longe, quite independently, set up his party with the Vercors' commander, the French regular Colonel Huet (*Hervieux*),²³ and got in touch with London for supplies. By the end of June the plateau was cleared of Germans, bright with tricolours, and full of people expecting a fight but knowing they were free. There have been endless disputes about why and on whose authority these people behaved so rashly so soon. The truth is that Chavant the mayor of Villard-de-Lans, the largest townlet on the plateau, had been taken over to Algiers in the spring by the *Casabianca*, and had brought back with him an order signed by General Cochet to call the Vercors out into open resistance 'le jour J', on D-day. Cochet did not explain whether he meant D-day in Normandy or D-day on the Mediterranean coast; the mayor did not stop to inquire.²⁴ Nor, apparently, did Cochet inform anybody in MASSINGHAM of what he had done.

By early July, though the EUCALYPTUS party and the operational group had done a lot of training and there had been some successful skirmishes with the Germans at the edges of the plateau, German probing patrols were getting more daring. On 11 July the last thousand *sédentaires* were called up by Huet; this raised the maquis strength to 3,200. The Vassieux dropping zone was being converted into a Dakota landing strip, and the Americans

dropped a thousand containers on it on the morning of 14 July; full of stens, ammunition, and badly needed clothes, but none of the heavy weapons that were more urgently desired still. The Germans kept up reconnaissance and light raiding from their airfield near Valence; and the big drop was greeted within minutes by fighter attacks and shellfire on the dropping zone. On the 18th elements of two or even three German divisions totalling some 10,000 men, with air support, opened a serious attack. For several days it was held at the cliff tops, thanks to the rugged ground, the fighting enthusiasm of the defenders, and the attackers' caution, due to a particularly successful earlier ambush in which the fifteen members of the OG had killed over a hundred Germans in ten minutes.²⁵ As they found they could make little progress, the enemy raised the stakes. On the 21st they landed a score of gliders on the Vassieux strip, carrying over two hundred SS; and these crack troops the lightly armed maquis were unable to dislodge. The effort to shift them absorbed the whole of Huet's reserve, through two days of drenching rain; and on the afternoon of the 23rd he gave the order he should by all the rules of guerilla have given five days before, the order to disperse. As the Germans overran the plateau they behaved with customary barbarity, burning and torturing, slaying everyone they could reach as nastily as they could. One woman was raped by seventeen men in succession while a German doctor held her pulse, ready to stop the soldiers when she fainted. Another, one of Pecquet's assistants, was eviscerated and left to die with her guts round her neck.²⁶

Not surprisingly, the allied liaison officers became separated in the confusion. Cammaerts wisely slipped away on the 21st; his responsibilities were so great that he could not let himself be imbrangled in any battle that could not be decisive. Conus was captured on the same day, and tortured; he was the last to be shot of a party of six lined up on the edge of a ten-metre ravine, and when it came to his turn jumped into the ravine and managed to get away. The wireless operators stayed together and succeeded in maintaining contact with base, a considerable tactical achievement; but had only intermittent contact with Huet, and lost it with Longe. Eventually Longe and Houseman found themselves alone with a local companion, and set out towards Switzerland, which they reached in a week's dangerous marching.

A chance remark by Cammaerts, exaggerated by a busybody, led to a torrent of gossip to the effect that Longe and Houseman had run away. In fact as Pecquet put it 'the Equipe Radio had a terrible time whilst in the woods, but ... to leave the Vercors can be considered a more dangerous feat'.²⁷ Eventually a court of inquiry was held at Longe's request in London, and found 'that the conduct of these officers was in accordance with the traditions of the British Army, and that their activities were entirely justified';²⁸ and Gubbins recommended Longe for an MC in recognition of 'courage and tenacity in very arduous circumstances'.

The proper use of maquis was nevertheless to be demonstrated within UNION'S area, before long. Two more UNION missions went in; an unlucky

all-American one including Ortiz to the upper Isère, landing with a mass drop of containers to Cammaerts on 1 August, and another allied one under D. E. F. Green (formerly in charge of the safe-breaking course) on 12/13 August to the Ubaye valley. Green's party were in an area so free of the enemy that they could all travel together in a charabanc.²⁹ Ortiz, accidentally taken prisoner, had the satisfaction of watching his captors, the notorious 157th division, trying to get across the Alps into Italy, take three days (23 to 25 August) to struggle forty miles up the Maurienne valley to Modane against an endless succession of small ambushes. 'Our progress', he reported, 'was very slow. They feared Maquis activity and we were preceded by a cyclist company. At each place where an ambush seemed possible the cyclists would dismount, deploy and make a wide reconnaissance.'³⁰

The maquis of Savoy had learned in fact, from the fate of their neighbours in the Vercors, the golden rule of guerilla: the task is to delay the enemy's passage over ground, not to hold it. This rule was put into effect with great success in central and south-western France under SOE auspices at the very moment when an over-formal conception of what irregular troops could be called on to do was precipitating the Vercors disaster. Here is an account by the second-in-command of the BERGAMOTTE mission of a routine hold-up in the Creusc in August:

... in a few minutes an unending stream of armoured cars, motorcars, motorcyclists, lorries, and occasional tanks appeared. They all seemed to be in slight disorder and were in no particular formation; private cars could be seen with troop-laden lorries on each side of them, and motorcyclists appeared at irregular intervals. The speed of advance was extremely slow – about 5 miles an hour – and there were frequent halts to remove a tree trunk, investigate a supposed trap, or reconnoitre the roadside. All this was a sure proof – if we needed one – that the maquis guerillas were feared, and were succeeding in their main intention of delaying the enemy. The troops we saw were both German infantry and miliciens ...

We had hardly arrived at a nice fold in the ground, bordered by bushes, when the noise of firing broke out on the road some kilometres to the rear of us, the other side of Bosmoreau. The noise of this ambush, though obviously some distance away, caused the whole convoy in front of us to stop. Officers and NGOs dismounted – we could now see every detail plainly – and began scanning the woods and hillsides with their binoculars. The troops themselves remained for the most part in their trucks, though LMG positions were immediately taken up near the road on the principle of 'all round protection'. Directly in front of us was a company of miliciens nicely grouped together and looking chiefly in the wrong direction – a sitting target!

Suddenly an intense volume of small arms fire spat out from a spot parallel with our own position, about a hundred yards to the left of us. It was the maquis section going into action. There were obviously about six

rifles (firing pretty rapidly for untrained soldiers) and two Brens emptying their magazines in rapid, prolonged bursts.

My two companions and myself opened fire immediately; one of us had a rifle, the other two had carbines. We fired as rapidly as possible into that mass of sprawling men, some of them tumbling from the trucks and others throwing themselves flat on the road. It was difficult to distinguish between dead and living, and for one whole minute there was every sign of confusion and panic.

Then a curious thing happened. It seemed as if the whole division went into action against us. Small arms, heavy machine guns, mortars, small pieces of artillery, began plastering the woods on our side of the road over a space of at least five hundred yards, and although trees and bushes on our flanks and rear were churned up, nothing dropped near.

It was so typically German! They found it difficult to locate us, they thought we were more numerous than we were, so they shot at anything moving – even a branch in the wind. They were using a sledge-hammer to crack a walnut – and missed the walnut!

As soon as the maquis section on our left ceased fire, which they did all together after a period of less than five minutes, as if under the orders of a good officer or NCO, we ourselves decamped. We went up that hillside as fast as we could on all fours, in order to keep out of sight, and were soon in the woods. I looked back once. Small arms fire from the road was now being directed more in our direction and this was evidently covering fire according to a fixed battle drill, for two parties could already be seen fifty yards from the road coming up to encircle us and progressing by ‘movement and fire’ alternately. (It was very much like British battle drill for an attack, as laid down in the army pamphlet ‘Fieldcraft and Battle drill’.) Judging by the last glimpse I caught of the scene at the roadside, there must have been at least 30–40 casualties, dead and wounded, among the enemy. It is, of course, very difficult to estimate enemy casualties in such circumstances.

What is more important is the large amount of delay and trouble caused to so strong a body of troops. They continued to fire in our direction with all calibres, long after we left that wood behind.³¹

This single illustration of a successful guerilla ambush, inflicting some loss in men, severe loss in time, and still more severe loss in emotional strain on the enemy, may serve to indicate the sort of thing that forces inspired by SOE were able to do in a thousand places at once behind the lines in France. This particular BERGAMOTTE party was a late one; the Germans whom it delayed and distracted were already on their way back to Germany. One important reason why they were on their way back to Germany was that a myriad of resistance actions had so much trammelled the whole process of army reinforcement to Normandy that local commanders there could no longer rely on reinforcements reaching them at any particular time or indeed at all. It would be absurd for SOE to claim all the credit for this. An

important part of it belongs to the allied air forces; another important part to those French railway resistance activities which were spontaneous, and derived from the railwaymen's own strong feelings instead of prompting from London or Algiers. Even among the groups of Frenchmen who came out into the hedges to hold the Germans up there were thousands who had never heard of any SOE organizer and had received no orders and no direct support of any kind from anybody outside France either. And yet the contrast between the behaviour of the French countrymen in 1940 and in 1944 is astonishing. As Liddell Hart pointed out at the time,³² a few well-felled trees backed by snipers could have done much to dislocate an armoured *Blitzkrieg*; but the rural population of France in 1940 took quite a different view of the Germans from the one it had developed by 1944. The causes of this change of heart are far to seek; among them certainly the propaganda of PWE – originally as SOI part of the first SOE concept – was prominent. And for the fact that the French who had sullenly accepted them four years before were enchanted to see them go in 1944 the Germans had themselves to blame most of all. And yet it is a fair claim for SOE that its teams and its weapons took the lead in producing this outburst of anti-German action. In a few of the largest cities, particularly in Paris, the lead in resistance fighting this summer was taken by the FTP whose relations with de Gaulle were never warm and with SOE were often chilly; the case of Paris will need particular attention below. But in the countryside, though there were a lot of armed FTP resisters in circulation, many of these were used by their communist chiefs – as some gaullist groups were used by gaullist chiefs – for party rather than national purposes. There was some tendency among them to settle local French scores instead of dealing with the Germans, and many instances are recorded in SOE's files of FTP units which, having once secured some weapons, refused to use them for any purpose that the PCF had not previously approved. With the widespread breakdown of communications that was one of SOE's and the air forces' principal achievements in France, it will be realised that PCF approval was seldom easy to come by: this was just what the communists wanted. It meant that with any luck the battle would have flowed past them, taking with it the most serious and best armed allied and local units, thus leaving the field open to the FTP troops who had been crafty enough to retain their arms to seize power locally. This at any rate is the accusation that has frequently been levelled against the PCF, both by its opponents and by politically neutral historians who still await any convincing rejection of it from the communist side.³³

It is worth looking at one or two particular phases of the SOE effort to delay the movement of German troops round France. One concerned only the movement of a single German division; but it was an SS armoured division equipped with the latest German heavy tanks; it was ordered up to Normandy from the neighbourhood of Toulouse where it was stationed on D + 1; and it did not arrive until D + 17. The extra fortnight's delay imposed

on what should have been a three-day journey³⁴ may well have been of decisive importance for the successful securing of the Normandy bridgehead. Affairs in the bridgehead went so badly for the allies in the first few days that the arrival of one more first-class fully equipped overstrength armoured division might easily have rolled some part of the still tenuous allied front right back on to the beaches, and sent the whole of NEPTUNE awry. What caused this long delay? Partly of course the destruction of all the bridges on the Loire between Orleans and the sea, effected in the first few days of June by the allied air forces; but naturally the 2nd SS Panzer division (*Das Reich*) had a bridging train to see it across the Loire – it had not fought across the wider rivers of western Russia for nothing; and while there would undoubtedly have been a check at the river, resistance or no resistance, it would never have lasted a fortnight. What ruined the move was the incessant guerilla activity, in which several F section circuits played a distinguished part. Before ever the order to move had reached the wretched division, some of George Starr's teams in WHEELWRIGHT were busy blowing up its petrol dumps, which Starr had had them mark down and prepare for attack weeks before. Short of petrol, the Germans turned to the railway; PIMENTO saw to it that only a single train went north. A single train was from the Germans' point of view practically useless, so after a further vexatious delay, hunting such reserves of petrol as they could find, they set off to march. But their march took them across Philippe de Gunzbourg's sub-sector of WHEELWRIGHT between Bergerac and Périgueux; or for those of them who took the more easterly road, through DIGGER's and many other audacious and well-manned ambushes round Brive and Tulle. DIGGER's men had a good deal to revenge, including all their dead of the previous autumn's fighting and their vanished leader Harry Peulevé, who at about this time attempted the unexampled feat of escape from Fresnes prison. (Like all good escapes, this was a simple one: on being returned to Fresnes from a fruitless interrogation at the Avenue Foch, he managed to mix himself up with a crowd of French visitors leaving the prison, got right to the main gate with them, handed the sentry a blank scrap of paper instead of a visitor's pass, and ran. His luck was out; the sentry gave a prompt alarm and he was wounded and recaptured in a garden nearby. Left without medical attention, he dug the bullet out of his thigh with a spoon.) Once the Germans had shaken themselves quite free of WHEELWRIGHT and DIGGER – and that took them the better part of a week – they had FIREMAN and Deschelette's teams to cope with round Limoges, backed by Maingard and Pearl Witherington with SHIPWRIGHT and WRESTLER, the SAS BULBASKET team near Poitiers, and Philippe de Vomécourt with VENTRILOQUIST, before ever they could sight the Loire. And north of the Loire were Hudson's revived HEADMASTER circuit in the Sarthe and east of it, to intercept them when they were directed on Caen where most of the British armour was, Claude de Baissac's SCIENTIST. Between them these circuits left the Germans so thoroughly mauled that when they did eventually crawl into

their laagers close to the fighting line, heaving a sigh of relief that at last they would have real soldiers to deal with and not these damned terrorists, their fighting quality was much below what it had been when they started. The division might be compared to a cobra which had struck with its fangs at the head of a stick held out to tempt it; the amount of poison left in its bite was far less than it had been. (It was against a different SS panzer division that Hugh Dormer was killed in action – back with his regiment as he would have wished – at the end of July.)

On its way north, the SS *Reich* division carved out for itself a private niche in the book of iniquity. Its mens' tempers had worn exceedingly thin. It had been held up at one point on the Dordogne, at the delightful town of Souillac north of Cahors, for the better part of forty-eight hours: one column including heavy machine guns and mortars was held up for four hours by only twenty-eight FFI, most of whom were killed.³⁵ Hold-ups of this kind naturally assisted the RAF, which had plenty of target-hunting teams about, and was several times able to inflict serious losses on the division while it was bunched on the main roads. In the course of the practically incessant sniping to which the division was subjected, almost as much when passing through villages or small towns as when it was out in the open country, a popular company commander was killed in a village called Oradour-sur-Vayres, some twenty-five miles west of Limoges. For his death the Germans extracted a price all the more extraordinary for being levied on the wrong village. Some SS turned up next morning at the village of Oradour-sur-Glane, which also lies roughly west of Limoges but is fifteen miles and more from Oradour-sur-Vayres. The whole population was assembled in the village square; the women and children were sent to the church; the men were shot down where they stood; and the church was then set on fire. Armed SS stood round it to make sure nobody got out alive. About seven hundred people were killed; but of course a few did get out alive, so that the name of Oradour has joined the names of Lidice and Kharkov in the blackest catalogue of man's treatment of man.

As with some other disasters arising out of SOE's operations in France, it would be absurd to say that the killings at Oradour were in any sense 'SOE's fault'. It is not even certain whether the original marksman in Oradour-sur-Vayres who killed the German advance party commander was a sub-agent of Mayer or any other resistance organizer, or not. The massacre does at least illustrate the same lesson as the Vercors: how German troops much subjected to guerilla treatment ceased to behave in accordance with what are curiously known as 'the laws of war'. The fighting quality of men who had done such things was low, and for its lowering SOE may claim some credit; though every member of SOE would deplore these results.

Several bodies of allied troops were meant to work in the interior of France during OVERLORD: two sorts of small SOE parties, under the code-names of BARDSEA and JEDBURGH, several larger SOE interallied missions,

the Anglo-Franco-Belgian Special Air Service brigade, and the American Operational Groups. These armed bodies deserve passing mention at least, for all but SAS came under EMFFIs 6^e bureau; and SAS, though not under command, was expected to co-operate.

The BARDSEA parties, who were Poles, never got off the ground; they were as the impermissible phrase goes – events are not self-propelled – ‘overtaken by events’. They consisted of a hundred Polish stalwarts who had eaten their hearts out in rage and anxiety ever since their training had been completed, well before D-day; they were highly skilled and competent underground fighters, all tough, all good shots, all demolition experts, all parachutists. Their role was to drop to MONICA receptions and help to lead the Polish secret army MONICA had prepared round Lille in harassing and confounding the German retreat. Politics kept them grounded; for the Polish government in London, passionately conscious of Poland’s woes, was determined these picked men should not be wasted, and after long wrangling secured an assurance that BARDSEA teams would only be dropped to districts the main allied forces were likely to overrun within forty-eight hours. None of the people who made this arrangement understood that it took about a day longer than forty-eight hours to get a BARDSEA operation mounted; and when it came to the point, the allied advance from the Seine to the German border at the end of August and the beginning of September swept past the Polish colonies in north-east France before their military potential could be realised. This sort of waste of well-intended effort is inevitable in wars. The Poles’ good intentions wanted to carry the BARDSEA troops over to the Warsaw rising, which was enduring its martyrdom at the time; logistics and politics alike made that impossible as well.³⁶

Ninety-three of the JEDBURGH teams did find their way to France; six to Brittany, and seven elsewhere, in June, the remaining eighty scattered over the country in the next ten weeks. Like almost all the other SOE agents going thus late into the field, the JEDBURGHs had to build on foundations laid for them already, by F or RF agents or by such local resistance leaders as they met when they arrived. Almost always they dropped to SOE receptions; this was as well, because a lot of their wirelasses were damaged by faulty packing, and without prompt communications with London they were useless. Xenophobe or at least Anglophobe French authors have suggested that the JEDBURGHs’ role was to restrict resistance operations to what suited the secret plans for world domination of the British intelligence service;³⁷ an unconvincing account of the purpose of teams many of which had only French members and all of which worked on SHAEF’s directions. In dozens of areas they provided liaison with the allied high command that was valuable for getting rid of the Germans; wherever they appeared they cheered people up, for they all wore uniform; at worst, they provided extra weapon-training and sabotage instructors for the resistance groups they joined. After a year and more under training, they were raging to get to grips with the enemy –

the Frenchmen among them above all, who knew the risks their countrymen of like mind had been running all the time.³⁸

That the JEDBURGHs' security was not seriously compromised by their uniforms is illustrated by the interesting fact that none of them was captured; their casualties were all sustained in gun battles with the enemy, or incurred at the very start of their missions by parachuting accidents. (Among these accidents, Mynatt's was noticed above.³⁹) Two members of the ANDY⁴⁰ team broke three legs between them on their initial drop. Deschelette (*Ellipse*) the nearest DMR sent them back to England at once by Dakota from Limoges airfield, which he controlled, and annexed ANDY's survivor as an extra wireless operator for himself. Like any other agents, they had their runs of luck, good and bad; a few were involved in bitter and important battles, particularly the Breton teams of which more shortly. All were agreed on one point: they had been sent too late. It had always been held that it would be suicide for men with marked American accents to go to work behind the lines until just before the moment of liberation, when there was overwhelming popular support to guide these self-proclaimed foreigners clear of the worst dangers; hence the restriction of JEDBURGH dropping to the beginning of OVERLORD. Such evidence as there is indicates that the policy makers were probably over-cautious here. It would certainly have helped to heighten the enemy's sense of insecurity if uniformed as well as armed parties of allied subversive agents had begun to operate in the interior of France in appreciable numbers for some months before D-day; but the risks in this particular case were large, and only the impetuous will wish to blame the allied command for not taking them.

The JEDBURGHs included about a hundred of the best junior officers OSS had available for work into France. The operational groups, much more thinly officered, were inexperienced, but otherwise about equivalent to SAS in fighting quality; like SAS, they none of them went to France before 5 June. Only half a group worked in the old ZO. Four OGs, each 34 strong, were sent from MASSINGHAM to strengthen likely areas of open resistance in southern France, such as the Vercors; their percentage of French speakers was much higher than it was in the British SAS regiments, their equipment was more lavish, and their training was at least as good. But some of them were over-cautious. One party hid for a week on reconnaissance in the barren hills of the Quercy, crept at last into the valley to blow up a railway viaduct, and demolished a whole arch of it by an over-use of plastic; only to discover, later, that the viaduct had been unguarded because the Germans had finally abandoned the area four days before the Americans blew it up.⁴¹

The *missions interalliées* were so various, both in size and in role, that they may most conveniently be set out in a table (see page 354); the more significant of them have already been, or will be, referred to at the appropriate places in the narrative.⁴² It is more than likely that several more of these missions,

TABLE V: INTER-ALLIED MISSIONS 1944

MISSION	Strength	Commander	Date sent	Area	Notes
UNION	4	Fourcaud	6 January	Rhône valley and Savoy	Thackthwaite, Ortiz, and Monnier the other members; withdrawn 6 May.
ASYMPTOTE	2	Yeo-Thomas	24 February	Paris	Thwarted by arrest of commander 21 March.
CITRONELLE	12	Bolladière	12 April and 5 June	Ardennes	Thwarted by enemy attack 12 June.
CLE	1	Racheline	15 April	Paris	To secure decentralisation of French resistance organization. In by sea.
BENJOIN	4	Cardozo	8 May	N. Massif central	Survived two major attacks in June; liberated Clermont-Ferrand on 27 August.
VERVEINE	6	Hutchison	5 and 10 June	Morvan	Close co-operation with SAS.
MUSC	3	Heslop	7 June	Savoy	<i>Cantimier-Xavier</i> mission of 1943 revived.
ISOTROPE	6	Baldensperger	8 June	S. Massif central	Successful.
BERGAMOTTE	6	Robert	26 June	Creuse	Imposed important delays on enemy reinforcements for Normandy.
EUCALYPTUS	6	Longe	28 June and 7 July	Vercors	Broken up by enemy attacks in mid-July.
TILLEUL	7	De Guélis	7 July	Corrèze	Successful, like BERGAMOTTE.
UNION II	7	Coolidge	1 August	Savoy	Put in with mass drop by day; one killed on landing; thwarted by capture of Ortiz and four others on 14 August; commander survived.
ALOËS	25	Eon	4 August	Brittany	Dewavrin 2 i/c. Muddled preparation; close co-operation with SAS and JEDBURGHs; striking success.
GIVETTE	2	de Clay	11 August	Paris?	Again with Bodhaine; presumably with a sabotage task. Result unknown.
UNION III	9	Green	12 August	Maurienne	Too late to be much use.
SNOW-WHITE	9	Croft	16 August	Hérault	Too late to be much use.
ÉTOILE	8	Broad	5 September	S. Franche-comté	Too late to be much use; in by pick-up; Morel 2 i/c.
SHINOILE	25	Willk	8 September	Vendée	Organized FFI investment of La Rochelle and St Nazaire.
SAINFOIN	5	Robert	10 September	N. Franche-comté	Dropped behind American lines.
PAVOT	6	Prendergast	11 September	Vosges	Too late.
CUT-THROAT	6	Hastings	15 September	Alsace	Half shot down on way; rest too late.

which ought to have appeared on the map at least, have been lost to history with the destruction of AMF's files.

Of the operations of the SAS brigade in France this summer a little has been said in participants' autobiographies,⁴³ and a lot more remains to be written; but not here. Almost the whole brigade strength of some 2,200 men was committed to battle in the three months that followed D-day; one unit, 4 SAS, all of whom had parachuted into Brittany by the end of June, lost nearly half its strength in killed and wounded, and the proportionate losses in some 1 SAS parties were higher still. Of the hundred-odd SAS prisoners of war, four escaped unexecuted, besides two rescued too badly wounded to stand from German military hospitals. Numerous SAS parties are indicated on Map 4; some main ones are worth specifying, for they all worked closely with SOE, and a retrospective SFHQ summary of activity in June and July said of them that 'they supplied the trained military direction which the FFI inevitably lacked, and in the areas where they operated, formed the hard core of French resistance in the field'.⁴⁴

Their supply system worked more smoothly and efficiently than EMFFI's supply arrangements for the JEDBURGHs did; over and over again JEDBURGH commanders remarked in their final reports that their SAS companions had been better and more promptly served. EMFFI's comparative inefficiency resulted directly from its size; it represented no reflexion on the merits of the Harrington and Tempsford squadrons who dealt with SOE compared with 38 Group's aircrew who serviced SAS. Though SAS's numbers in the field in France eventually exceeded SOE's, and the navigation problems were much the same for reaching either sort of party, SAS had the advantage of sending stores to fewer spots with more carefully trained reception committees, and the greater advantage of a simpler and smaller staff. SAS's problems were complicated enough – about a dozen different authorities had to consent to every new SAS venture – but one over-worked staff captain with a deputy, and a DADOS and another deputy, managed by prodigies of telephoning to keep the supply lines open. All SAS operations were controlled from the brigade headquarters, at Moor Park golf course, close north-west of London; and the principal brigade staff – the usual brigade major, staff captain, and intelligence officer – found that in spite of a host of extra officers attached for special purposes each of them had to have a deputy to enable him to keep pace with the incessant torrent of work. Telephone insecurity was fearful, but brought no disasters, and the work got done; with a total staff still smaller than that of any of EMFFI's six bureaux.⁴⁵

The main operations SAS ran that need notice here were five.

The largest fixed British party, HOUNDSWORTH, was in the Morvan mountains midway between Dijon and Nevers, under Bill Fraser a squadron commander with desert experience. Hutchison (*Hastings*) went to the Morvan on the night of D + 1, with the ISAAC mission – soon renamed VERVEINE – to join the HOUNDSWORTH advanced base set up the night

before. Many reports from HOUNDSWORTH testified to the variety and inaccuracy of the intelligence Hutchison's maquis contacts produced;⁴⁶ but the presence of a uniformed British lieutenant-colonel did a great deal to sustain maquis morale, and VERVEINE helped HOUNDSWORTH to make about half a department uninhabitable to the enemy. The Germans made one serious attempt to scour out the forest where Fraser's squadron lurked, believing that an infantry battalion strengthened by one armoured car would turn the trick; but the armoured car was no match for Fraser's hidden six-pounder, and the infantry quickly lost heart.

BULBASKET, under Tonkin, also sent in its advance party on D-day, received by SHIPWRIGHT and accompanied by the HUGH JEDBURGH party; nearly fifty strong by the end of the month, BULBASKET was established near Poitiers, hampering traffic on the railway to Tours and providing useful target intelligence for the air force.⁴⁷ But on 3 July they were trapped by an SS infantry battalion; a third of them were captured and at once shot, and the rest were brought out of France on one of SOE's Dakota operations.⁴⁸

GAIN, a third 1 SAS group, worked some thirty to fifty miles south of Paris in the gap between the Loire and the Seine; HERMIT arranged its early receptions and provided local friends. Ian Fenwick commanded it with the verve his famous *Punch* cartoons suggested. He lay up by day athwart the main German lines of land communication with the Normandy front, for all the Seine bridges were down; at night his squadron sallied out in parachuted jeeps, tacked themselves unobtrusively onto the tails of German convoys, and opened fire whenever a good chance offered. This was too near the Gestapo's Paris stamping ground to be long tolerable; GAIN only ran for three weeks from 14 June before a double agent enabled the Gestapo to raid Fenwick's base. A reinforcing party from England arrived on 4/5 July to find their dropping zone under fire; Fenwick was killed next morning, and a dozen of his men who could not disperse in time were captured. Kieffer interrogated them for a month, without much result. He then had them changed into plain clothes and taken back from Paris to the neighbourhood of their base to be shot. One of them had the wit to notice the firing squad was only armed with Stens, and ran off unscathed through the woods; so this episode was eventually fatal to Kieffer. Fenwick's driver also made a distinguished escape; he was unconscious when captured, came round in a German hospital, and with a French nurse's connivance borrowed a doctor's uniform and limped away.

WALLACE, the 2 SAS jeeping operation under Roy Farran, covered a great deal more ground, but was hardly more successful than GAIN. When the fighting front at last became fluid with the American break-through at Avranches, Farran's twenty jeeps bristling with machine guns were flown to Rennes airfield, whence his squadron swept in a great arc across northern France. At a cost of seven killed and three missing they wreaked extensive damage on the Germans and gave a lot of uplift to the French – much of

it transitory, for they moved fast. They landed on 19 August, reached an advanced base prepared by parachute near Dijon on the 23rd, lay up for a few days, and after another four-day bound were near Epinal. But WALLACE'S adventures, though romantic, were more cavalry than clandestine warfare.

Similarly SWAN, a run of small 1 SAS raids through the lines of the Normandy beach-head in July, had really been ordinary infantry work, for which parachutists were no better suited than a good infantry battalion. Most of the rest of I and 2 SAS went in mid-August on TRUEFORM, an attempt to harass the impending German retreat by jeeping and ambushing in SALESMAN'S old area east of the lower Seine. 3 SAS, one of the brigade's two French units, was dispersed – uniformed, like the rest⁴⁹ – on many missions to stiffen resistance south of the Loire.

The other French unit, 4 SAS under the indomitable one-armed Commandant Bourgoïn, had a more concentrated role and a more important task, called DINGSON, in Brittany. It was Bourgoïn's advance party under Marienne that landed north-east of Vannes on the Landes de Lanvaux a little before midnight on D – 1/D-day;⁵⁰ accompanied by F's HILLBILLY under Hunter-Hue, the surviving member of PARSON.⁵¹ Hue had been trained as an organizer since his escape, and took a wireless operator with him. Bourgoïn's instructions were to 'sever, as far as possible, all communications between Brittany and the remainder of France';⁵² he found German control of Brittany already weakening, and proceeded with SOE's and the American army's help to destroy it.

Within a few hours of his own drop on 10/11 June he was in touch with five separate battalions of indigenous resisters, and hard at work on his parting orders from 21 Army Group, one of his many superior headquarters: 'a full-scale revolt is to be raised in Brittany'.⁵³ HILLBILLY and six JEDBURGH parties helped him to receive arms and supplies for the large numbers of resisters who were bursting with anxiety to come out of clandestinity and kill some Germans; and within a few days there was a crowd of about two thousand maquisards milling round the DINGSON base. Impromptu SAS arrangements supplied them all with British uniforms, small arms, boots, food, and ammunition, and they dispersed to the bases they had come from; but no one could hope to keep so widely known an operation secret. Bourgoïn described the atmosphere he dropped into as 'like a fair', shouting, fancy dress, crowds, exaltation, lights everywhere.⁵⁴ Almost as many had collected at SAMWEST, Bourgoïn's other concentration area near Guingamp; and the COONEY parties, eighteen three-man SAS rail cutting teams dropped on 7/8 June, had almost all joined SAMWEST or DINGSON within a week. (COONEY and the remnants of LA BÊTE NOIRE did their work well; secret reports indicated that 'when the enemy moved 3 Parachute Division out of western Brittany on 11/14 June he did not try to move any of it by rail'.⁵⁵) The concentrations were of course dangerously large, and drew immediate German attention. SAMWEST was the object of a set-piece attack by a

Russo-German infantry brigade on 12 June, and after a few hours' resistance wisely scattered, leaving the enemy to beat the air; as an observer at Moor Park noted at once, 'It is fatal for SAS to assemble a large concentration of men, particularly of half-armed maquis; it is bound to draw down on the area heavier forces than it can repel ... [yet] it is impossible for the enemy to crush guerillas who will not stand and fight'.⁵⁶ On the 18th, an equally large force, stiffened by armoured cars, attacked DINGSON from the desolate camp at Coëtquidan near Rennes. By a lucky wireless accident, the defenders were able to get forty P47 Thunderbolts to support them in the late afternoon, when they had fought the Germans to a standstill; this provided tremendous encouragement, not only on the battlefield but all over Brittany, whither the bush telegraph spread news of it at once, and correspondingly depressed the enemy.⁵⁷ Bourgoïn was too wily a fighter to be rounded up methodically in his heathland base; he gave the order to disperse overnight, and there was no foretaste in Brittany of the blood-baths of Montmouchet and the Vercors.

By now every Breton who was going to help the allies was anxious to enrol, somehow, behind Bourgoïn's liberating army of some four hundred Frenchmen. The SAS were hidden in isolated farms and forests with little trouble; constant German searches for them, made for safety's sake in larger and larger parties, had smaller and smaller results. By the end of July SAS had a force of over 30,000 maquisards – some estimates put the figure as high as 80,000 – armed and roughly trained for infantry fighting in the Morbihan and the Côtes du Nord. And when the Americans broke through at Avranches, Brittany rose to meet them. Till the outskirts of the U-boat bases at Brest and Lorient and St Nazaire, the American armoured columns met virtually no opposition as they trundled down the main roads; SAS and SOE between them had taken care of the rest. A large SOE mission called ALOES, under Eon, a battle-experienced French colonel (appointed at the request of the mainspring of the party, Dewavrin), dropped on 4 August⁵⁸ – behind the leading Americans – to take over general control, but never quite caught up with Bourgoïn. As McLeod put it after a three-day visit to him in mid-August, 'the name of SAS stands extremely high throughout Morbihan. There is not the slightest doubt that had the 4th Battalion not been put into Brittany at the beginning of the campaign, resistance would not have been organized and equipped as it was'. In spite of forty per cent casualties, 'Discipline is first class and morale is extremely high. The unit regards itself as largely responsible for having liberated Brittany'.⁵⁹ Eisenhower, reviewing the campaign a year later, was not too remote from the battle to forget SAS, and observed on this operation:

Special mention must be made of the great assistance given us by the FFI in the task of reducing Brittany. The overt resistance forces in this area had been built up since June around a core of SAS troops of the

French 4th Parachute Battalion to a total strength of some 30,000 men. On the night of 4/5 August the État-Major was dispatched to take charge of their operations. As the Allied columns advanced, these French forces ambushed the retreating enemy, attacked isolated groups and strongpoints, and protected bridges from destruction. When our armor had swept past them they were given the task of clearing up the localities where pockets of Germans remained, and of keeping open the Allied lines of communication. They also provided our troops with invaluable assistance in supplying information of the enemy's dispositions and intentions. Not least in importance, they had, by their ceaseless harassing activities, surrounded the Germans with a terrible atmosphere of danger and hatred which ate into the confidence of the leaders and the courage of the soldiers.⁶⁰

The role of providing tactical intelligence for more cumbersome forces was not one that SOE or indeed SAS had ever been intended to play. Nevertheless as several examples have shown it was one that operational parties on a useful spot might be able to perform well, and both organizations were sometimes called on for this purpose to supplement the numerous SUSSEX teams. SUSSEX was nothing to do with SOE; it was run by the intelligence service. Many of its parties had been active in France since May,⁶¹ but they did not provide complete cover of the area behind the battle front. The Belgian SAS company carried out several useful missions of this kind in France, mostly road-watching; and one SOE circuit was devoted to it entirely. This was HELMSMAN, created by F's Jack Hayes to meet a specific requirement Brook reported from SFHQ. The Americans on the right flank of the NEPTUNE landing reported themselves short of tactical intelligence; Hayes's task was to supply it. He dropped on 10 July to a reception arranged by de Baissac near Avranches; in ten days he had collected thirty intelligent local volunteers, nearly all of whom managed to creep through the lines bearing messages from him about enemy dispositions. In a month his work was done; the American army found it of exceptional value. Opposite the British flank of the NEPTUNE fighting, de Baissac threw off a sub-circuit from SCIENTIST to do the same sort of thing. Dandicolle (*Vérger*) ran it, for a time with success comparable to HELMSMAN's; but their neighbourhood was too full of Germans, and on 7 July he and his wireless operator – M. L. Larcher, brother of a former *Scullion* – were caught during a transmission, shot it out with their captors, and were killed. Similarly Bodington's new PEDLAR circuit on the Marne provided some useful R.AF targets. Eileen Nearne of WIZARD, who had transmitted a good deal of economic and military intelligence besides helping in the routine work of arranging drops for SPIRITUALIST, was caught at her set in July. She brought off a dexterous bluff, and persuaded the Gestapo she was only a foolish little shopgirl who had taken up resistance work because it was exciting; they never discovered she was half English. But they took her away to Germany all the same.

Four more of F section's girls, also bound for Ravensbrück, were captured during the summer. Violette Szabo jumped back with Liewer the night after D-day, to start SALESMAN up again near Limoges, far from the abandoned lower Seine. Three days later, on a car journey with two of Liewer's assistants, she ran into a body of angry Germans in a country lane; both sides opened fire. She and her companies fled in different directions; she tripped and was taken prisoner. Denise Bloch's arrest was less dramatic – she was Robert Benoist's courier in the revived CLERGYMAN circuit, and not even his expertise could disentangle them from a Gestapo trap. He was arrested in Paris on 18 June, on a visit to his dying mother. Next day the Gestapo raided another Benoist château near Rambouillet where they caught Mlle Bloch and Mme Wimille. Her husband dodged so nimbly between their massed cars in the drive that no one got a shot at him, and hid in a stream with only his nose above water till they had gone. His wife found herself a few weeks later in a milling crowd of fellow-sufferers in the courtyard of the Gare de l'Est, awaiting transport to Germany; caught the eye of a cousin at the wheel of a red-cross van; nipped into the van, put on a white coat, and handed out sandwiches till she could be driven away to safety. Blondet, dropped with a million francs as Benoist's assistant two nights after his organizer's arrest, had the presence of mind to shoot an officer on the reception committee who mistook him for a Gestapo colleague in the dark and addressed him in German; the newly arrived agent promptly cleared out and turned up eventually helping FTP groups in the Aveyron, far south. His experiences in the escape from Eysses had evidently kept him alert.

In this kaleidoscope of dramatic episodes, a few more casualties to old acquaintances need notice. Landes, busier than ever in Bordeaux, finally sent word through a cut-out to Grandclément that an aircraft was coming to take that vain man to England; Grandclément took the bait, and was liquidated by ACTOR that night. George Wilkinson of HISTORIAN was arrested near Orleans at the end of June, and Lilian Rolfe his wireless operator at Nangis a month later (she was caught accidentally, when the Germans raided the house where she was staying while they were pursuing someone quite different). André Studler their American assistant was also taken prisoner, but escaped and rejoined the circuit. Allington, a second assistant, who was wounded fighting with it outside Orleans, had co-operated usefully with Fenwick's SAS patrols. Mulsant and Barrett on the other hand were captured on their way to extricate an SAS party which had got into difficulties in the forest of Fontainebleau. In an effort to rescue his old friends, Cowburn parachuted into France for the fourth time on 30 July; but neither he nor Dumont-Guillemet was able to get onto their track in time to save them from Buchenwald.

De St Geniès also was caught, by a macabre accident. Two days after CADILLAC, the first mass daylight drop by the USAAF, the inner circle of

SCHOLAR dined together at their best safe-house, a cheese factory near Dôle, to celebrate the safe stowing of thirty-six Fortress-loads of arms. A sub-agent in his middle teens was caught nearby carrying a transmitter, and the Germans raided the factory. They found only the caretaker's wife, wringing her hands beside a table laid for eight, and an atmosphere of alarm. An NCO, impressing on her that he meant business, fired a random burst of bullets through the ceiling, and so shot through the head of de St Geniès who was hiding in the loft. The bloodstain was at once noticed, and Yvonne Baseden and several companions were found and arrested. Aubin arrived from England a few days later, to reinforce the circuit he found headless; his AUDITOR took over many experienced SCHOLAR and DIRECTOR sabotage teams, and eventually liberated Lons-le-Saunier. Sevenet, like de St Geniès, had the luck to be killed in action – in his case, in an unequal engagement with a Messerschmidt, on the Black Mountain near Carcassonne on 20 July. Sarrette also was killed quickly, by a mishandled mortar bomb at a training demonstration in the hills of the Nièvre on 5 September. Tessier, captured back in January at the downfall of MUSICIAN, did a classic escape from the Place des Etats-Unis, breaking through an outside wall with a stolen bar and turning his bedding into a rope; he worked hard for SPIRITUALIST, but was killed in the eastern suburbs of Paris at the end of August. Henri Frager's luck was as bad as ever; while Bardet's teams were doing a little sabotage in the Yonne, he was himself pursuing the mirage of his long-standing negotiation with *Colonel Henri*; believing always that he knew better than the London authorities who warned him off it, till at last on 8 August an almost tearful Bleicher slipped handcuffs on him and sent him away to Buchenwald.

The general picture was far from one of gloom; beside each of these casualties several circuits in good working order could be set. The whole of eastern France was so thick with ambushes and resisters that the German 11 Panzer Division, which took a week to reach the Rhine from the eastern front, took three weeks more to struggle from the Rhine to Caen. The entire French railway system was so shot through and through with subversion that the Germans had practically to abandon its use over much of the land they were supposed to hold. As a rueful and authoritative German survey put it, it was not so much the actual damage inflicted by the allied air forces, or even the incessant minor demolitions of the saboteurs, that made the railways unworkable; it was the permanent attitude of non-co-operation and go slow of the railway staff, even when they were not on strike, that made it impracticable to clear up enough of the mess for trains to run.⁶² The contrast, on roads and railways alike, between the summer of 1940 and the summer of 1944 could hardly have been more marked.

The prolonged hitch in Normandy, that lasted from the middle of June, when Montgomery failed to capture Caen at once as he had planned, till the last days of July when the Americans finally broke through on the other flank, was a trying and testing time for many distant maquis. Anne-Marie

Walters' account of how things looked in the south-west may be taken as typical of what many resisters felt:

Things were not so easy as during the first days. The Dordogne was too important to the Germans as a communication centre. They had besieged the Department with a couple of SS divisions, and carried out ceaseless attacks on the maquis. Within a short time the maquis had run out of ammunition and had dispersed. The parachutages had become rare; the Allies' first task was to arm the circuits immediately behind the front, to enable the Resistance to destroy German reinforcements on their way to Normandy. In Dordogne, the Fourth Republic had fallen, and the population suffered pitiless reprisals. It was at this time that the village of Oradour-sur-Glane was razed to the ground, and men mowed down with machine-gun fire and the women and children burnt alive in the church.

People were getting discouraged and morale had dropped lower than at any time during the days of the Underground. This was not peculiar to the Dordogne alone. The fighting on the distant beaches of Normandy seemed to make no progress. The airborne landing in the south-west was definitely not going to happen. The war in western Europe seemed to threaten to be a long one. The Germans had gathered renewed daring and terrorised the population with their savagery. Ammunition and supplies were getting short. The men had no boots and no clothes; their families lived with difficulty without their daily earnings. Yves, so full of enthusiasm the first day, had not had a single parachutage within the first month of his arrival. The best-served maquis seemed to be ours: more neighbouring groups had joined us, and the Armagnac Battalion now counted twelve hundred men.⁶³

But the delay was only temporary. When the NEPTUNE front broke open as Montgomery had intended, and Patton started his race to the Rhine, DRAGOON the landing on the Riviera the Americans and French had long insisted on at last took place on 15 August. So thoroughly had the termites of resistance eaten away by now the pillars that German authority rested on in southern France that the whole structure crumbled to powder in days.⁶⁴ Brooks emerged from two years' clandestinity, stuck a Union Jack on the bonnet of a powerful car, and set about some experiments in brewing up German road transport with phosphorus grenades; some of his PIMENTO teams were prominent beside the communists of Villeurbanne in the street fighting that raged for a day and a night across that industrial suburb of Lyons. Heslop kept out of industrial areas; he simply directed the affairs of the Ain and Haute Savoie, persuading both FFI and FTP to follow his orders-veiled-as-suggestions for getting rid of the German armies. George Starr, an agent of equal force of personality, was equally successful in the south-west. Cammaerts saw his JOCKEY teams and their neighbours perform just as he wished, holding open the *route Napoléon* from Cannes through Digne and Gap to Grenoble

and so enabling DRAGOON to outflank such main German resistance as there was, in the lower Rhône valley. At last, however, the Gestapo caught him personally; he was arrested at a road control with Xan Fielding. His new courier the Polish Christine Granville (*Pauline*) by a combination of steady nerve, feminine cunning, and sheer brass persuaded his captors that the Americans' arrival was imminent, and bought the party's release three hours before they were to have been shot.

Malraux, after the liberation, hailed this clearing of the road to Grenoble as one of the two major repayments that resistance had made to the allies, 'which amply made up for the admirable help that English parachute operations had brought us for so long. We must not forget', he added, 'that the allies did help us; that we were armed by them; that without them, we would have had nothing. At the present moment, in this respect, France can be grateful, but Resistance owes no debt.'⁶⁵

The success of the resistance forces in the south-east inevitably poses again the familiar commentators' question: was DRAGOON worth mounting at all, or might the war have been brought to an end sooner by some other concentration of DRAGOON'S forces farther east? Might not the Rhône valley resistance movements have liberated themselves unaided?

They might; the Germans in Provence could well have pulled out northward, pursued by maquisards, when Patton threatened to cut them off; just as the Germans in Aquitaine and the Limousin pulled out, in the last ten days of August, with WHEELWRIGHT, FOOTMAN, FIREMAN, SHIPWRIGHT, BERGAMOTTE, TILLEUL and a host of other groups yapping at their heels like angry terriers closing on a fox, when Patch's army advancing fast up the Rhône did threaten to cut them off from such tenuous contact as they still had with Germany. Forces totalling nearly 100,000 of these withdrawing troops were finally cornered near Limoges by the forces the Mayer brothers, Liewer, and Philippe de Vomécourt inspired; they insisted on having some Americans to surrender to, and the Americans to the fury of the French treated them amicably, loading them with such things as oranges that had hardly been seen locally for four years.⁶⁶

One reason for mounting DRAGOON has been touched on lightly, if at all, by English-speaking commentators, and deserves notice here. Whether the operation was necessary or not, for political or for military reasons, to the Americans or the British, it was indispensable for de Gaulle and for French national self-assurance. Seven of Patch's eleven divisions were French, the revived French North African army combined with some of the best of the gaullist volunteers, and commanded by de Lattre de Tassigny whom SOE had brought out of the former ZNO. De Gaulle alone of the leading allied political commanders looked at the war from Algiers; seen from there, a formal reoccupation of French soil by French troops was something that simply could not be done without. SOE's part in this necessary operation was to ensure that it went through with the minimum of friction.

SOE's direct part in the liberation of Paris was slight; though not as negligible as a few writers have supposed, who take the old-fashioned view disproved in 1870–71 that the fate of Paris decides the fate of France, and suggest that the struggle for national liberation and the struggle for control of the past and future capital can be more or less equated. But for AUTOGIRO, PROSPER, DONKEYMAN, SPIRITUALIST, but for the BOA, the Parisians would have had few arms but pistols; but for RF section and Charles de Gaulle its inspiration, they would have had little hope. Yet neither de Gaulle nor *Leclerc*, neither Eisenhower nor Gubbins can properly claim the title of liberator of Paris. If that title must go to a single man, it must go to a German: General von Choltitz, the last commandant of Gross-Paris. He was European, or human, enough to preserve the city, by disobeying his barbaric orders from Hitler to defend it stone by stone. Von Choltitz was removed at the end of July from his unsuccessful command of LXXXIV Corps round St Lô;⁶⁷ in Paris he replaced von Boineburg-Langsfeld, who had conducted only too successfully the arrest of the entire senior SD staff in Paris late on 20 July – the one part of the plot against Hitler that had run smoothly. Dozens of SS officers were shut into Fresnes, and by a macabre irony were markedly reluctant to leave their cells after the plot collapsed, knowing too well the technique behind the phrase 'shot while attempting to escape'. Unfortunately for their SOE prisoners, their overnight substitutes had been efficient army guards.⁶⁸

Yet why did von Choltitz dare to disobey his orders, with examples so fresh in his memory of what was happening to the conspirators of 20 July? Because the people of Paris effectively liberated themselves: they built themselves up into so formidable a body of determined supporters of the allies that even though their weapons were few – on the eve of the explosion, Tanguy (*Rol*) the FTP commander only knew of 600 weapons he could call on⁶⁹ – their will to be free of the Germans could not be resisted by any sensible man.

The story of the revolt has been so lucidly set down by Dansette that there is hardly need to do more here than refer glancingly to the gradually diminishing supplies of coal, of gas and electricity, of food; to the growing restiveness of the internal resistance leaders, headed by COMAC, at the braking applied by Moulin's successor Parodi the gaullist delegate-general on their efforts to precipitate an insurrection; to Parodi's provision, nevertheless, of the essential supplies of SOE's money without which the rising could never have been sustained; to the railway strike of 10 August, the police strike of the 15th, the communist posters calling for military action posted on the night of the 18/19th,⁷⁰ that led next morning to the hoisting of the tricolour on Notre Dame and the Hôtel de Ville and the first open skirmishes in the streets; to the CNR's proclamation of open resistance later that day,⁷¹ which brought on stiffer fighting; to the truce arranged direct between von Choltitz and Parodi late that evening, spasmodically observed

for a few days; to the sharp street fighting that followed; to the ingeniously worded false report of Paris's liberation, circulated in error by the BBC – with august support, from Downing Street and Buckingham Palace – on the 23rd;⁷² to the arrival at the Hôtel de Ville at a quarter to nine next evening, in scenes of frenzied excitement, of the leading tank troop of *Leclerc*'s free French armoured division, accompanied by a motorised column of maquisards under Marc O'Neill;⁷³ and to von Choltitz's surrender on the afternoon of the 25th. De Gaulle entered the city just afterwards, and went to the ministry of war. There he found everything, down to the blotting-paper on his desk, as he had left it in 1940. He refused Bidault's request that he should proclaim the republic anew, saying it had never ceased to exist. The great crowds of citizens, feeling themselves free at last, who simply in the end elbowed the Germans off the streets of Paris, provide the one clear example in this whole tale of successful popular mass action. Moreover, their success was a treble one: the demonstration was not only anti-nazi and pro-allied, it was pro-gaullist.

No one who was present in Paris that week could forget either the deserted streets where small arms crackled in the days of fighting, or the hunger, or the fear, or the uncertainty, or the final joyous passion of the crowds. Dansette's account of the apotheosis on the 26th deserves repeating:

From the workshops of Montparnasse and the markets of Bercy, from the hovels of the rue Mouffetard and the shops of the Faubourg Saint Antoine, from the great houses in the Avenue Foch and the huddled camps in the out suburbs, men, women, children, the people of Paris came up, more and more numerous as they neared the centre, coagulating in a dense swarm. By three in the afternoon they had formed a gigantic crowd, crammed in irregular layers on iron chairs, stools, ladders; waiting, along a way bright with tricolours, for a glorious procession to pass. At the Etoile, tanks⁷⁴ fan out to cut the open space in two, facing down towards Concorde, leaving open the side towards the Champs Elysées. Generals Koenig, *Leclerc*, Juin, Admiral d'Argenlieu – the whole high command of fighting France is there. The police band strikes up; General de Gaulle is coming, '*Vive de Gaulle! Vive de Gaulle!*' He reviews the men of the Chad frontier force, drawn up in line, and lays a cross of Lorraine made of pink gladioli on the sacred stone. '*Vive de Gaulle! Vive de Gaulle!*'

No doubt, as official processions always do, this one will drive down the Champs Elysées.⁷⁵ But no. Loudspeaker cars address the crowd down the route: 'General de Gaulle confides his safety to the people of Paris. He asks them to keep order for themselves, and to help in this task the police and the FFI who are weary after five days' fighting.' Four tanks lumber forward, *Lauragais*, *Limagne*, *Limousin*, *Verdelon*. Behind them, blocking the avenue, come forward arm-in-arm policemen, FFI, first-aid men, soldiers, in a human chain; a fireman, a postman, even a negro grinning from ear to ear are among them. Behind, in disorder, come

motorcycles, sidecars, overloaded jeeps; then after an empty space an usher in a black coat, with a white shirt front: and a silver chain, very solemn; behind him, at last, a throng of people with a few officers half-hidden among them. In the front rank there is one man in uniform; he is a head taller than the rest. ‘*Vive de Gaulle! Vive de Gaulle!*’ the crowd yells. He walks with a springy, rather nonchalant stride, and replies tirelessly but without warmth to the cheering, with that gesture of both arms he had used at the Hôtel de Ville the evening before to greet Paris. If he notices he is a little ahead of his retinue, he slows down so that he is level with them. To tell the truth, people who have not got good seats cannot set eyes on him; but they cry as confidently as the rest ‘*Vive de Gaulle! Vive de Gaulle!*’ Behind him, after two or three ranks of silent officials, a human herd prances, dances, sings, enjoys itself utterly; from it there stick out tank turrets sprinkled with soldiers and with girls whose destiny does not seem likely to be a nunnerly, cars crammed full, placards, some of them written in Spanish, and a huge banner in the Spanish republican colours, purple, yellow, red, which spreads right across the avenue: a crowd flowing between two crowds.⁷⁶

So vast a demonstration – de Gaulle himself estimated the crowd at about two million⁷⁷ – settled the question whether the French wanted him. But the shooting was not quite over yet; a fusillade broke out, probably by accident, when the general reached the porch of Notre Dame. His troubles were only just beginning. All over France, old debts were being settled among the French, to the tune of some thirty or forty thousand lives; no one was yet in power.

The casualty figures in this French internal dispute will never be known this side of doomsday. The official number of summary executions, announced in the aftermath of the 1951 elections, was 9,673; more than half of them attributed to the period of the occupation. This figure is certainly too low, at least where killings after the liberation are concerned; in November 1944 Dewavrin was given a total as high as 105,000 in a talk with the minister of the interior. This in turn is certainly far too high. The point is not one on which SOE’s archives throw more than a few faint rays of light; for as the next chapter will show most of the British and American agents were withdrawn when their neighbourhoods were cleared of Germans, and most of the French ones were rapidly absorbed in the revived French forces. The figure of 30,000 to 40,000 is taken from the brief, informed discussion in Robert Aron’s book:⁷⁸ it amounts to about one in a thousand of the French population.

The main political question of *prise de pouvoir* that so much-occupied the minds of French resisters, and is entangled with the equally spiny problem of allied military government in liberated territory, has been treated at length in two official histories, by Donnison from the British and Hostache from the French angle⁷⁹, and needs no more than summary here. The

American, still more than the British, army staffs expected to set up some milder version of the allied military government in occupied territory (AMGOT) that had served their turn in Italy. De Gaulle had no wish to see Pétain or Laval treated as another Badoglio or Darlan, and refused to participate in anything of the kind; asserting that to treat with the existing vichyste authorities in France would be to play straight into the hands of the communists. As it turned out, the civilians in the NEPTUNE beach-head were happy to welcome de Gaulle, who with some dexterity replaced the Vichy sub-prefect at Bayeux with a resistance leader from Caen. The new man knew nothing of administration, but was a strong gaullist and a fast learner; the British and Americans accepted the accomplished fact; and as OVERLORD developed the advancing allied armies found gaullist administrators taking charge of the villages and towns they cleared of Germans, often before the last of the snipers had been cleared away. While the Norman beach-head front was fairly static, there was little contact with resistance; Bardet's friend Kieffer, the DONKEYMAN sub-agent in charge of the area, had worked more efficiently for his namesake in the SD than for F section, and F's real activity in Calvados had been minimal ever since the end of AUTOGIRO two years before. RF had been outmanoeuvred there also. When the front became more fluid, in such areas as eastern Brittany in early August gaullist MMLA detachments could be found intermingled with local resistance leaders in more or less close touch with SOE as they came out of hiding.

In Paris, the provisional government quietly took over the offices of the principal departments of state, in a series of neat minor operations which were unobtrusively carried out in the course of the insurrection. By the time the Germans had gone and the dust of the crowds that welcomed de Gaulle had settled, acting-ministers – men agreed on months before between the CNR and the CFLN – had started to run the central machinery of government,⁸⁰ aided by acting permanent heads of departments chosen through the same secret channels; while de Gaulle's nominees were supervising the affairs of the newly liberated provinces. The communists had relied on a mass rising in Paris to provide an irresistible revolutionary impetus, which could transform the face of France and which their experienced men on the spot would have every opportunity to direct. The gaullists pursued, with superior insurrectionary skill, another line of Trotskyist thought: they seized the railway and electric power stations and the places where ration cards were issued, all over France, and thus came to control the French state.⁸¹ With the military defeat of the German army on French soil, the whole structure of Pétain's *Etat Français* was whirled away down the wind of history: it had rested on German bayonets, and when they left it collapsed. Thanks to their own dexterity and to communist ineptitude the gaullists succeeded, in course of time, in taking charge everywhere; and what happened then is also rather a subject for the next chapter than for this.

XIII

Aftermath

A postwar rhymester, Lionel Hale, amusing himself as Baker Street was closing down, thought it would be

happy and handy
If Bodington baffled the coastguards
By smuggling in claret and brandy,
And super-de-luxe dirty postcards.¹

But in fact remarkably little on these lines was done in Great Britain after the war, a tribute to the unadventurous orderliness and to the absorbent qualities of British society. The British agents who returned to Great Britain seem to have remained on the right side of the law; though many of them revealed, sometimes years afterwards, scars made by the strains they had undergone. A few had nervous breakdowns; a number found themselves in the divorce court. Two foreigners had more summary treatment. A Pole who had returned from France saying he had run out of funds was caught trying to place a large block of French francs on the black market in Knightsbridge. And in April 1946 Déricourt was arrested at Croydon, on his way to pilot a civil aircraft back to France, with a substantial quantity of gold and platinum for which he had not troubled to secure an export licence. Viewing what appeared to be his excellent war record, the magistrate let him off with a £500 fine; the fine was paid for him by a private acquaintance never connected with any government.² Otherwise nothing to report.

In France there was much more confusion and dismay. The American and British armies, anxious to press on into Germany, were only interested in the safety of their lines of communication towards the front, up the Rhône valley from Marseilles and across northern France from Brest, Cherbourg, and such other ports as they were able to open. Much of central and south-

western France was left in a state uncomfortably near anarchy, as nobody any longer took any notice of the few former Vichy local administrative authorities who had not been deposed by the local resistance; and the incoming gaullist provisional regime, formally unrecognised by the British and Americans till late October, short of men and shorter of experience, was only slowly and painfully able to make its presence felt. The central civil service changed sides again, though less smoothly than in 1940; NAP's arrangements were not quite complete enough. De Gaulle continued an interesting experiment in regional government, begun under Vichy, and sent particularly trusted men with the new title of *commissaires de la république* to take charge of groups of seven or eight departments at once. This led to a little trouble with SOE.

Most of the *commissaires* had formerly worked with RF; Bertaux for instance, who came into this story near the beginning working with Labit in Toulouse. When Bertaux returned to Toulouse he found George Starr practically in control of the place. Ayer,³ who was there when de Gaulle came on tour on 16 September, reported that 'there is a legend in Toulouse that the Germans in 1943, already believed [Starr] to be a British General sent in to direct the whole of Resistance in the South West. At the time of the Liberation, the whole of the area was in the hands of a series of feudal lords whose power and influence was strangely similar to that of their fifteenth century Gascon counterparts. Among these barons [Starr] was, without any question, the most influential.⁴ But Starr had to leave shortly thereafter, after a memorable row with General de Gaulle. The general asked the agent what the devil he had been up to, and – little understanding the origins of his own power, or the circumstances that had brought him to Toulouse in triumph – denounced Starr as a mercenary and all his followers as mercenaries as well. When Starr pointed out that many of his followers held French commissions, this only made the general angrier still; and this anger left Starr in no mood to remark that he had conducted WHEELWRIGHT under Koenig's orders and in strict loyalty to the man who was now denouncing it. When de Gaulle ordered him to leave immediately, Starr replied that he could not recognise him as his commander, and must refer the point to the allied high command; moreover his local responsibilities were not such that he could divest himself of them in five minutes. To the threat of arrest Starr quietly replied that he was at the general's disposition; well knowing that nobody in Toulouse would lift a finger to touch himself. A dead silence followed. Starr's bravery had made its impact on de Gaulle, who rose, came round the desk he sat at, and shook Starr's hand.⁵ Starr nevertheless had to leave in not very decent haste. He was back in England on 25 September. In the end the French authorities relented towards him, and he received a Croix de Guerre and Légion d'Honneur to add to his British DSO and MC.

On 17 September de Gaulle went on to visit Cusin, the *commissaire* at Bordeaux; Cusin of course invited Roger Landes to all the junketings. De

Gaulle refused to see him, except to tell him that he must leave the country within two hours; a decision that was soon known in Bordeaux and produced a crowd of four thousand demonstrators outside the hotel where Landes was staying – demonstrating enthusiastically for the agent against the general. Landes left the town, but not the country; he rejoined one of his own maquis groups in the pine forests to the south, and is alleged to have contemplated marching on Bordeaux on his own account. It soon struck him that he could do nobody any good by this course, least of all himself; and he also returned to England, on 10 October.

The chief difficulty that the gaullist *commissaires* had to wrestle with was that everybody they met claimed to have played an important part in the resistance; many of them supported their claims with the documentation everyone had learned to forge so well during the troubles. When Bertaux arrived in Toulouse he went to sit in the prefect's office in the empty prefecture and waited to see who would come. Among the scores who came to assure him of their devotion to the cause of resistance and national liberation there were he thought far too many *naphthalinés*. He adopted the technique of putting the same question to each fresh face: 'since when have you worked in the Resistance?' One answer disconcerted him; 'since '36. I was at Guadalajara.' There were plenty of Spanish republicans, like this one, about in the south-west; the British embassy in Madrid displayed some uneasiness at the prospect that they might renew the struggle against Franco in Spain, and the British Foreign Office was also uneasy at the prospects of some sort of left-wing rising instigated through the FTP. So were many senior non-communist resisters in France, among whom there were widespread rumours of a plot, due to break out any day.⁶ As it turned out, nothing came of these scares; either there never was a plot, or it was bungled, and therefore cancelled. Yet it was noticeable in many areas that the FTP remained where they had been working, and hung on to their arms, while as many as 137,000 FFI – also still armed – hurried off to the east of France to enrol in the French army as it approached the German border.⁷

A few circuits of course were still in action in the second week of September, when the bulk of France was cleared of German occupiers. Most of the FFI in the Atlantic coast departments settled down, under-armed and under-clothed, to the siege of the under-fed low-grade German garrisons that held out in the U-boat bases. The Americans cleared Brest at once, fighting hard for a place they thought essential; but most of the other ports held out longer even than the collapsing Reich, and did not surrender till 8 May 1945. A single American infantry division, the 94th, and some French SAS sufficed to stiffen the FFI resistance; ALOES helped look after Lorient, and another mission two dozen strong, SHINOILE, sent in on 8 September, provided staff and signals for the resisters round St Nazaire and La Rochelle.

Away on the eastern border, battalions of ex-maquisards played a prominent part in the autumn fighting in STOCKBROKER'S and CHANCELLOR'S areas

near Belfort; and some of the last of SOE's *missions interalliées* got involved on the edge of it too. Richard Broad, whose variegated war career had included getting left behind at St Valéry with the Highland Division in 1940 and a long spell planning commando raids for Mountbatten, went out to Heslop's MARKSMAN landing-field on 5 September with Morel and six other companions, in a mission called ETOILE to work in southern Franche-Comté; Robert, back from BERGAMOTTE, took the SAINFOIN mission into northern Franche-Comté only five days later, and found he had been parachuted behind the American lines. Prendergast likewise, with PAVOT in the Vosges, arrived too late to do any useful clandestine work; so did Hastings, the senior survivor of the nearby CUT-THROAT. SOE in fact found in September what SAS had discovered with SWAN in July and with TRUEFORM in mid-August. In a fast-moving retreat there is little that armed infesting parties can do behind a fluid battle-line but lay ambushes, which the local population – once armed – can be relied on to do anyhow; in 1944 in French-speaking country, at all events. And once the battle-line has settled down, little or nothing can be done by SOE or SAS-type parties that cannot be done better by fighting patrols from the units on the spot, unless lengthy preparations have been made. Nobody had made any in time behind the line on which de Lattre's, Patton's, Bradley's, and Montgomery's armies stuck; so clandestine war in France came to a standstill too.

It was against this background that de Gaulle visited the south-west. And the re-emergence of more or less regular warfare provides at least an explanation, if not an excuse, for all those formerly retired officers who got their uniforms down again from their attics, and took the places they were used to at the heads of companies and battalions they had done nothing to raise or train. 'Pour un biffin, on est dix colonels', as a sad maquis song in the Charente had it;⁸ real fighters were at best aghast, at worst ashamed. Heslop, active in France in peril of his life for two years and more, the principal pillar of the resistance structure that had made the passage of DRAGOON'S armies north-eastwards from Lyons so simple, narrowly escaped imprisonment at the hands of the new men who did not understand who he was.

One or two other people who had been active in France had narrower squeaks still; among them another resister with Spanish experience, who was glad of it. Jeschke, who had worked as one of DF's most successful organizers, had not hesitated to work under Wehrmacht cover; he had ridden a stolen Wehrmacht motorcycle in plain clothes, with forged German papers to account for his possession of it. The allied advance eventually caught up with him in Belgium; and some earnest Belgian resisters who knew nothing of DF denounced him to the nearest allied unit as a German in plain clothes, producing the motorcycle as evidence. The nearest allied unit were Poles, who brushed aside Jeschke's certificate, just obtained from the newly opened SOE office in Brussels, with the remark that any fool can forge a

certificate. They were about to shoot him; in the nick of time the sergeant of the firing squad recognised him as a platoon companion in Spain eight years before.⁹

The business of clearing up SOE's circuits and lines in France was most of it conducted from an office in the Hotel Cecil in Paris. F and RF sections each sent an investigating mission round France with the code-name JUDEX, commanded respectively by Buckmaster and Thackthwaite. The RF JUDEX report has not survived; the F report¹⁰ consists principally of names, speeches and menus.

This is not the place to review the course of French politics after the liberation. But this narrative of SOE's work in France must conclude with some account of what happened to the agents. The thousands of sub-agents who had been proud to risk their lives, often on the orders of British officers, usually by the handling of British stores or weapons dropped by British aircraft, did not receive much in the way of direct thanks from any British government authority. Certificates of commendation of various kinds were prepared in London and distributed in France. As we have just seen, any fool can forge a certificate; but there was a worse difficulty in SOE's way when these were being distributed. Many deserving sub-agents could never get their deserts, because the agents who might have drawn official attention to them had fallen into enemy hands. Many of the most deserving sub-agents had fallen into enemy hands themselves. Most of the French survivors had to fall back on the private knowledge that they had done what they should and what they could; as de Malval once put it, 'people who have simply done their duty have no need to boast about it in public'. Good men and women could at least say '*J'ai le coeur tranquille*', my heart is whole.¹¹ During the war F section and the special duty squadrons between them generated tremendous potential for Anglo-French amity, by a myriad practical demonstrations to the French that the British did care about setting them free from the nazis. This stock of anglophil feeling has been dissipated by inattention and neglect, and overlaid by tragedy.

The inattention and neglect have caused a lot of sore feeling, but little could be done immediately to avoid them. The narrative above has made clear how hostile General de Gaulle was, throughout its existence, to F section; with a gaullist government in power in France, it would have been an exceptionally delicate task for the British to do anything more than the decent minimum to look after former F agents or sub-agents whom the gaullists were bound to mistrust. This long continuing mistrust did not, of course, apply to agents of other sections or other services; such a body as the RAF Escaping Society could maintain and stimulate contacts with members of service escape lines in France without riling the gaullists at all. It is hard to say when the British might ever have taken up touch again with former friends in F circuits without having their efforts misconstrued by the French authorities.

The tragedy arose from nazi government policy; for not many of the arrested resisters who went to Germany came back. For them was reserved Himmler's full and final treatment;

The mere slaughter of the *Führer's* enemies was of no importance to him. They should die, certainly, but not before torture, indignity and interrogation had drained from them that last shred and scintilla of evidence which should lead to the arrest of others. Then, and only then, should the blessed release of death be granted them.¹²

Two hundred thousand French men and women were killed in German concentration camps; seventy-five thousand of them belonged to one sort of resistance movement or another. Twenty thousand more resisters had been killed in action or shot soon after arrest in France.¹³ Nearly all the captured F and RF section agents were deliberately liquidated by the Germans, as a matter of secret service policy: it was thought unsuitable for the allies ever to discover what had happened to agents who had fallen into enemy hands. Two dozen London-trained F agents and nine RF agents lived to tell the tale of their captivity; over a hundred had been taken prisoner from each section. Some of them succumbed to the truly appalling conditions in which they were held. In one big camp at least, Belsen, prisoners were so desperately short of food that many of them ate raw fragments cut off their dead companions' bodies.¹⁴ Most of the agents who were strong enough to survive the insane 'ordinary' regime were butchered in two distinct massacres: one in the first half of September 1944, the other much later on, a few weeks from the end of the European war, on 29 March 1945. On directives issuing directly from Hitler, most of them were hanged, as the conspirators of 20 July were hanged, with nooses made of piano wire; this was meant to make their deaths as slow and as degrading as could be. Nevertheless they almost all impressed their fellow prisoners with their lasting defiance of the enemy; many sang the Marseillaise on their way to the scaffold, and cried 'vive l'Angleterre, vive la France' as their last words. The SD threw in two F section wireless operators, Bloom and Norman, with the party of forty captured Dutch agents for whom they organized an extra murderous pair of days at Mauthausen.¹⁵ On the other hand, Gustave Biéler is said to have made so powerful an impression on his captors that when the order for his execution came from Berlin even the SS at Flossenbürg mounted a guard of honour to escort him as he limped to his death.¹⁶

It may be worth listing the survivors of the British-trained agents who were sent to Germany. From RF section, de Kergorlay, G. E. Ledoux, Lencement, the Letac brothers, Richard Heritier, Pelay, Schock, and Yeo-Thomas. From F section: the Colditz party – Pierre de Vomécourt, Abbott, Burdeyron, Cottin, du Puy, Fincken, and Redding; and from the camps, Yvonne Baseden, Burney, Peter Churchill, Lee Graham, Janyk, Le Chêne,

Martinet, Mattei, Eileen Nearne, the Newton brothers, Peulevé, Odette Sansom, Sheppard, Southgate, John Starr, Stonehouse, Tunmer, and Zeff. And from DF, Zembsch-Schreve who like March-Phillipps's Sergeant-major Winter managed in April 1945 to escape and find his way into the Allied lines.

These two were not alone in getting away; but it was exceptionally difficult to do so. Colditz was a fortress, with all that implies for escapers;¹⁷ the camps were worse still. They were surrounded by floodlit double electrified fences set in wide open spaces, guarded by alert sadists who were crack shots; inside the camps existence was so hectic and informers were so many that the arrangements for tunnelling or wire-cutting that were common form in prisoner-of-war camps were usually quite out of the question. On top of the routine difficulties, agents were often subjected to particularly close watch. Many spent long months under constant guard in solitary concrete cells. A few were kept permanently chained. One party of nearly a dozen were chained together in a circle, on arriving at a transit concentration camp, and made to run round and round till they dropped, whereupon they were whipped back to their feet and started round again; this went on all one long afternoon. Under this degree of duress, escape was outside any bounds of possibility. When released to the merely appalling conditions of ordinary concentration camp life, agents had to face the hostility of the communists who ran most of the camps' internal affairs; men who regarded British and French, particularly British, officers as their particular *bêtes noires*.¹⁸ It says much for Burney's stoicism and serenity that he was yet able to get a resistance movement of a kind started up among the prisoners in Buchenwald, the vast camp built round Goethe's oak on the beech-strewn heath outside Weimar. Burney made an intelligible, disastrous mistake in setting about this laudable if hopeless task: he selected his men on his own assessment of their character, without regard to their political views. Consequently his group was early interpenetrated by some of the more admirable of Buchenwald's communists, who kept their own party informed of this rival organization to their own and kept Burney away from the communists' few dozen hidden sub-machine-guns. When in the end the camp guards ran away, Burney and his surviving SOE companions – Southgate and the two Newtons – were lucky not to be liquidated before the Americans arrived a few hours later.

Seven months before, there had been over forty allied agents in Buchenwald; how had they been reduced to four?

A party of thirty-seven, headed by Yeo-Thomas, arrived from Compiègne early in September 1944 after a severe journey, during which several had got out of their handcuffs and tried to escape; pressure from some of the rest had prevented them. (During the early part of this journey Violette Szabo, who was on the same train, distinguished herself by crawling round distributing water under fire from the R A F, while the guards were hiding beside the track.) At first they were slightly better treated than the rest; and

when fifteen of them, Frager, George Wilkinson, Dubois, Barret, and Mulsant among them, were summoned by name to the camp office on 6 September; the others all thought it was for some administrative purpose; the fifteen did not return, and Polish acquaintances in the crematorium squad disillusioned the survivors next day. Three days later another group, of sixteen,¹⁹ were summoned; they disappeared in their turn.

After this double tragedy,²⁰ a desperate expedient was tried. It was devised by Eugen Kogon, a Viennese lawyer who was one of the few survivors of the original 200 prisoners sent to set up the camp eight years before, and Alfred Balachowsky, the professor of entomology who had worked under Suttill near Paris. Both these savants were now made to work in the block for medical experiments. They persuaded Ding-Schuler, the SS doctor in charge of it, to allow three prisoners from the group of agents to exchange identities with three Frenchmen dying of typhus, whose bodies were to be cremated as soon as they were dead. Ding-Schuler, it was understood, would reinsure himself with the allies by agreeing to this; though when it came to the point in September 1945 and he was tracked down and arrested, he killed himself before evidence for or against him could be heard. Balachowsky chose Yeo-Thomas as one of the survivors; he in turn chose Peulevé and an agent of Dewavrin's, Stephane Hessel. The exchange was only carried out in the nick of time in Peulevé's case, for he was summoned to the gate-tower for execution before the Frenchman he was to impersonate was quite dead, and had immediately to be injected with drugs to simulate typhus that almost carried him off in earnest. Luckily for him the chief camp doctor was on leave that week-end, and the elderly Austrian locum who came over from camp headquarters with a syringe bearing a lethal injection had not the heart to plunge it in the body of a man visibly racked with a high fever, handed it to one of Kogon's male nurses who was in the plot, and went away.

It was comparatively easy for the three changelings to slip back in their new identities into blocks full of French prisoners, and to get outside the main camp on working commandos; and in the last few weeks of the war Yeo-Thomas and Peulevé did better still, and escaped altogether. Yeo-Thomas was recaptured; passed himself off as an escaping French air force prisoner of war; escaped again, from a prisoner of war camp; and reached an American unit in the end. Peulevé escaped on 11 April, the second anniversary of his escape from Jaraba on his way back from his original mission. This time he also was recaptured, almost within rifle-shot of the Americans, by two Belgian SS; whom he persuaded of the danger of falling into allied hands in that uniform. 'Déshabillez-vous', one of them replied; both began to undress, intending to divide Peulevé's few plain clothes between them. He picked up one of the pistols they had laid aside; declared himself a British officer; and handed them over as his prisoners to the advancing Americans a few hours later.

The few who came back from the camps were haunted by them for the rest of their lives. No one in England could at first begin to understand what they had been through. When the emaciated Brian Stonehouse returned to London, two FANY friends who barely recognised him invited him to their flat for lunch, and lavished a week's meat ration on the occasion; as the chops began to cook, he rushed into the street with a cry: 'I can't bear the smell of burning flesh!'

So far this camp record has dealt with the men. What happened to the captured women has been a good deal exaggerated; but the true tale is terrible enough. Fifteen of the fifty of them who were sent from England fell into German hands; and only three of these fifteen survived. (Three others were taken by the French – two later escaped and another was released by the advancing allies; and one died suddenly of meningitis in the field²¹). The Germans divided these captives into two groups: seven went into Karlsruhe civil prison in the Rhine valley, accompanied by Sonia Olschanesky, the JUGGLER courier who had worked for SOE but had never been trained by it; the other eight went to the concentration camp at Ravensbrück, fifty miles north of Berlin.

The Karlsruhe arrangement suited Josef Kieffer, who made it. His family lived there, and on the plea that he needed to make further inquiries of these prisoners, he was often able to secure a night at home; never in fact calling on them. These people had nothing to do but keep up their own spirits and cheer their companions, petty criminals and minor political offenders, with encouragement about the forthcoming downfall of nazism; several of them made an unforgettable impression of courage and integrity on their fellows. There they might have stayed till the war was over, had not an officious wardress got into her head that their position was somehow irregular: they had never been tried, but they were sharing cells with convicts, except for Noor Inayat Khan, the first of them to arrive, who was long kept in chains in a cell by herself in the subsidiary prison of Pforzheim. In her efforts to get their position regularised, this busy-body of a jailkeeper drew the attention of the local Gestapo to their existence. Gmeiner its head, who had previously served with one of the notorious Einsatzkommandos on the Russian front, was a man who loved order, but knew not the meaning of mercy. He telegraphed to the RSHA for instructions; the file went up to Kaltenbrunner, probably to Himmler also; and came down again.

One morning in July 1944, Vera Leigh, Diana Rowden, Andrée Borrel, and Sonia Olschanesky were suddenly taken by train to the concentration camp at Natzweiler in Alsace; Stonehouse of F section and Guérisse of the PAT line saw them arrive in the evening, and Guérisse recognised Andrée Borrel who had once worked with him. He had already got into communication with them when, unusually early, all the prisoners in the camp were ordered into their huts; later that evening the four new arrivals were taken to the camp crematorium, each given a lethal injection, and put straight into the ovens.²²

The other four, Noor Inayat Khan, Yolande Beekman, Eliane Plewman, and Madeleine Damerment, knew nothing of their companions' fate; nor did the last three know of Noor Inayat's presence near by till she joined them on 11 September. Orders for them also had now come down over Kaltenbrunner's signature; and they were warned that evening to be ready to move next day. Gmeiner's cars called early to take them to the station; and they had an enjoyable journey through the day, chatting with each other in English and admiring the sunshine on the Swabian mountains. Near midnight they reached a station not far from Munich, and walked up hill together to a strange camp; it was Dachau. They were put in small separate cells overnight. First thing in the morning, they were called out together into a sandy yard, and told to kneel down by a wall. They saw the old bloodstains in the sand, and knew their fate. They knelt two and two, each pair holding hands; an SS man came up behind them and shot each of them dead, neatly, through the back of the neck.²³

At Ravensbrück there was more hugger-mugger. Most of the eight women agents sent there arrived at different times; they were expected to take their chance, and sink or swim – most probably sink – in the maelstrom of concentration camp existence. Those who have not experienced these modern hells can form no properly vivid conception of their beastliness; and the right to try to picture it on paper belongs best to the sufferers who survived.²⁴ It is worth remark that the camps had a considerable role to play in the Nazi economy, and that their prisoners were expected not merely to exist but to work, and work hard, on a diet of acorn coffee, turnip soup, and a little dry bread. It was expected, in fact it was intended, that they would all be worked to death.

This was probably the fate that overtook Cecily Lefort. Her health finally broke down early in 1945, and she allowed herself to be put on a transport to the *Jugendlager*, a nominal rest camp where sick prisoners were sent to waste away from starvation, or were disposed of more promptly in the gas chambers. The indefatigable Mary Lindell, a former escape line organizer who was a fellow prisoner and tried to keep some rationality afloat on this tide of evil fantasy, attempted to transfer Mrs Lefort to an outside working group where conditions were milder; but the effort just failed to connect in time.²⁵

At about the same time, Mme Rudellat vanished, and was presumed to have gone the same way. Eileen Nearne continued to put on her act of being a sweet little thing who knew nothing she ought not; no-one but she had any time for sweetness in Ravensbrück, but she managed to talk herself onto a comparatively light working party near Markelberg in Silesia, and from this in mid-April by a remarkable feat of bravery and level-headedness she managed to escape. She picked her way across ruined Germany into American hands. Yvonne Baseden also succeeded in getting away from Ravensbrück. She worked there as inconspicuously as she could, as a farm

labourer under armed guard, till she fell ill with tuberculosis in February; Mary Lindell, again, kept an eye on her, and managed to get her removed to Sweden by a red cross team in April.

Three other young agents were less fortunate. Violette Szabo, Denise Bloch and Lilian Rolfe were sent out together on a working party, found the work endurable, and asked to go on another when the first was done. Their second group turned out much fiercer, and by the time they returned to Ravensbrück late in January only Violette Szabo's irrepressible cheerfulness and stamina could keep the other two going at all. A few days later, on an order from Berlin, they were taken out and shot together just as the four girls had been shot at Dachau; they died within earshot of Odette Sansom's cell. For Mrs Sansom was given special treatment at Ravensbrück. Fortunately, in a paradoxical way, for her, some Germans thought she was Winston Churchill's niece by marriage, and she owed her survival to the resultant confusion. So far from being left to take her chance with the ruck of the thousands of women in the camp, she was kept for many months on end in solitary confinement in a small dark concrete cell, hard by the execution ground where every day the sound of shots would tell her that her enemies had killed some more of her allies. In moods of sadism or anglophobia her captors would starve her, or subject her to extremes of light or darkness, heat or cold. In the bitter end, when it was clear even to Fritz Sühren the camp commandant that the 'thousand year Reich' had crumbled away, he put her in a smart sports car and drove her into the American lines; in the vain hope that her influence would save his neck.

The reader will notice that awful as the sufferings of these women were, the allegations of fiendish brutality towards them by the Germans that are freely and frequently made are by no means all of them borne out by the facts. Their captors handled them roughly as a matter of course; as jailers have handled their prisoners from time immemorial. In German concentration camps the jailer-prisoner relation was about at its lowest; the main alleviation of life in Buchenwald, for instance, was that prisoners were seldom used for target practice on Sundays. The women in Ravensbrück lived surrounded by this kind of desolate horror, which those in Karlsruhe were spared. In fact only two of the women were picked out for extra personal indignities in Germany; Mrs Sansom, as has just been shown, and Noor Inayat Khan, who was kept in chains at Pforzheim.

Some of them had undergone worse things in France. Yolande Beekman and Eliane Plewman were both knocked about the face a good deal immediately after capture, in perfectly fruitless attempts to make them betray their friends. Yvonne Baseden had her bare toes stamped on, for the same purpose; her courage held also, and she said nothing.²⁶ Eileen Nearne even survived, in silence, the full revolting treatment of the *baignoire*. And terrible things were done to Mrs Sansom in the Avenue Foch, including burning her near the shoulder-blade. Those tortures also were wholly useless; as is proved

by the survival of Rabinovitch and Cammaerts. Through Cammaerts' survival, F Section was enabled to mount a circuit of exceptional value to the allied cause; and Mrs Sansom's heroic silence received the exceptional distinction of a George Cross, of which she was the sole surviving woman holder. In the longer run Kieffer, the responsible German, was hanged; though not for this crime.²⁷

It is also right to mention another tale of torture, the sad story of Violette Szabo's sufferings,²⁸ which is derived from the citation for the George Cross awarded to her – a decoration her outstanding gallantry had amply earned already. Whether or not she was subjected to personal violence, she was certainly later in a bad working group dependent on a very bad concentration camp; and whatever she may have suffered at the hands of the secret police in France was possibly not much worse than the degradations she and her millions of companions had to endure from the secret state police in Prussia.

By the time the allies did overrun the largest camps, they were in a state of entire chaos. Belsen, which the British freed on 15 April, was populated by scores of thousands of wraiths in the last stages of emaciation in which life could still be sustained, and ravaged by a typhus epidemic on top of the prevailing dysentery. Unnoticed among the hundreds of prisoners suffering from both these diseases at once was a Frenchwoman who called herself Mme Gauthier, who had arrived from another camp six weeks before. Her only close friend in Belsen was separated from her in the middle of March by the iron circumstances of that insensate world; she was then as well as any one could be amid the prevailing lack of food, fuel, clothing, decency, privacy, what civilised communities call 'the necessities of life'. She 'was not in bad health, she suffered occasionally from loss of memory, but she remained in good morale and she looked neither particularly drawn nor aged'.²⁹ But she soon fell dangerously ill. When the camp was captured, she was too far gone in her diseases, or too steeped in her cover story, or both, to mention to a soul what she had been; unnoticed to the last, she died on St George's Day or the day after, and her body was huddled with twenty thousand others into one of the huge mass graves. Her name was Yvonne Rudellat.

XIV

Strategic Balance Sheet

SOE was set up with the advice and consent of the regular service chiefs of staff; and although it was not fully integrated into the Ministry of Defence's system, on the whole they were able to lay down its strategy. It provided an exceptionally economic means of attaining strategic ends, and the chiefs of staff and their assistants had all been brought up to approve the doctrine of economy of effort as a fundamental strategic principle. Yet while they paid lip-service to this doctrine, in fact they pinned their faith on the big battalions. They did this because the great war of 1914 had been their main formative experience, and because a lifetime's training had accustomed them to the handling of great fleets, massed bodies of troops, aircraft marshalled by scores of squadrons; there had been no equivalent to SOE when they were young, and they never came to terms with this new weapon as they managed to come to terms with, say, armour or radar.

This was partly because what the new weapon was, and what it could do, were never fully explained to them; nor did they think it proper to inquire. This reticence, again, was due to the experiences of 1914–19, when the British forces had been served by a remarkable intelligence system of which the guiding rule had been total secrecy of method.¹ Here SOE suffered from its origin; Holland's GS(R), from which it largely derived, had become MIR with a niche in the military intelligence directorate of the War Office before ever SOE was born. SOE was strictly an operational body; primarily a user and only incidentally a supplier of intelligence, it was yet – because of its MI and SIS origins – regarded by the other service and supply departments as an intelligence organization. This hampered its work, for it hindered both SOE's superiors, and bodies with which it had to co-operate, from understanding what SOE was for. Yet in France it was much more an asset than a liability to be thought to be associated with that quasi-omnipotent body '*L'Intelligence Service*'; the IS myth carried many of SOE's agents through

awkward passages on their journeys, though it also exposed them often enough to gossip and to requests for aid that it was impossible to fulfil.

Myths apart, how well did SOE carry out in France the operational tasks that all its founders from Holland to Churchill had wanted it to perform?

Among the coups de main not many were rewarding. RATWEEK had some effect, particularly in the Lyonnais where the ARMADA team was looking after the executions; but there was nothing on this front in France to compare to the killing of Heydrich in Czechoslovakia. The only high-level assassination affecting the French directly was Darlan's; and though SOE was concerned in the results of that much admired event, it did not bring it about. Besides, Hitler or Himmler were the only other people on the axis side whose removal would much have affected the course of the war; and neither of them ever provided a target accessible to SOE's agents in France. Hitler took a good deal more care of himself than Churchill did;² where not even staff officers with daily access to him in Germany and Poland managed to kill him,³ no blame can rest on the SOE sections working in France for having failed to attack a fleeting opportunity target. No one, in any case, ordered them to attack it.

The results of industrial sabotage in France were only moderately good in terms of damage and delay to enemy war production. One reason for this only partial success was that the types of intelligent thug who were thought to be best qualified for sabotage work were most of them attracted into the commandos or SAS. The record of SAS in the quite different circumstances of the western desert is a good deal more distinguished, in terms of ammunition and aircraft destroyed, than that of any circuit in France; indeed Paddy Mayne, later CO of the 1st SAS Regiment, is credited with having destroyed with his own hands forty-seven enemy aircraft in a single night, a larger number than any RAF fighter ace managed to shoot down in the whole war.⁴ Nevertheless, SOE did include some men of distinguished ability in this highly specialised field; most of them like Mayne were not thugs at all; and they were able to overcome the difficulties inherent in sabotaging while acting as semi-permanent underground agents. None of the commando-type parties parachuted into France by F or RF section for specific sabotage tasks did anything really noteworthy, except for the ARMADA team which was in a class by itself.

The principal value of SOE circuits that dabbled in sabotage, as most of them did, was military rather than economic; for frequent runs of attacks on factories from outside, however slight, did at least divert enemy attention and enemy forces onto guard duties which might otherwise have been left to works police, besides providing training for the saboteurs. The difficult task of assessing how large a proportion of the German troops in France became absorbed in anti-sabotage duties and was thus abstracted from the conventional fighting front cannot be undertaken here, but deserves attention. It is worth remarking that on many occasions planned attacks on factories had to be called off because the factories turned out to be too heavily guarded:

these certainly were formal failures, but only relative failures, because to distract enemy forces from 'the front' on to guard duties was a success in itself.

On the military side at home, an unintended complication was inserted into the British war machine through SOE's subordination to the Minister of Economic Warfare. This subordination was only nominal – MEW and SOE staffs treated each other as equals, its objects were to provide some cover and some ministerial direction for SOE, and the junction between the two bodies the Minister controlled took place at the topmost level, his own desk. Now Sir Arthur Harris, the commander-in-chief of bomber command from February 1942, long had his knife in what he once described as 'the amateurish, ignorant, irresponsible and mendacious MEW',⁵ a body which favoured the 'panacea targets' he derided and disapproved his efforts to lay all Germany in ruins and so win the war. The fact that SOE depended on the same Minister as this despised department prejudiced him further against an organization which in any case was a rival to his own. He was a man of power; his temper was notoriously short; he lived a few minutes' drive from Chequers; and he wielded strong influence on Churchill.

Yet the competition – for that was what it amounted to – between SOE and bomber command deserves some serious attention. For all the differences between the two forces in size and in areas and methods of work, they had a number of points in common. Each began its struggle with inadequate means; each found itself attempting to do things that had never been done before; each could claim in the end some outstanding successes, for which each paid a notable price in casualties. And each was attacking the same types of target: oil, communications, aircraft factories, airfields, submarines, morale. SOE could never attempt, would never have wished to attempt, the sort of destruction that bomber command attempted in its spells of general area bombing; but the military significance of damage does not have to vary directly with its extent.

SOE suffered from a trouble that also afflicted the air forces, lack of crystal clear directives; and some of SOE's directives were muddled, as happened in other and even more technical fields, by lack of understanding of the nature and powers of the weapons the force wielded. A second trouble shared with the RAF was insufficient intelligence about the kinds of targets that were worth attacking. Twice SOE in France took on the 'panacea targets' that bomber command did its best to avoid: oil in the autumn of 1941, electric power in 1943–44. In the first case the results were negligible, owing as much to bad original intelligence as to inadequate resources in agents. In the second they were important, but indecisive. SOE had busy target and intelligence sections, under Boyle's experienced eye, hunting incessantly for weak links, though never finding any weak enough to cripple Germany.

As some preliminary contribution to argument on this subject, the reader will find set out in appendix G a note of the principal confirmed industrial

sabotage achievements in France. The most interesting thing about this list is that the total quantity of explosives used to produce all these many stoppages taken together was about 3,000 lb (1,360 kg);⁶ considerably less than the load of a single light Mosquito bomber in 1944; only a quarter in fact, of the weight of a single *Tallboy* bomb. (*Tallboy* was the RAF's biggest bomb available in 1944; *Grand Slam*, first used early in 1945, was 10,000 lb (4,500 kg) heavier still.)⁷ On 8 June 1944, when *Tallboys* were first used, one out of nineteen dropped by 617 Squadron blew in the mouth of an important railway tunnel near Saumur;⁸ the others made eighteen impressive holes in the surrounding fields. This gallant raid was necessary for reasons of internal air force politics: *Tallboy*'s supporters had to produce a demonstration of what the bomb could be made to do in action. But the same tactical result could have been achieved without risking 135 of the finest bomber aircrew in the world,⁹ through the agency of the WAAF flying officer who was commanding SOE's nearby WRESTLER circuit. Rail cuts were a speciality of hers.

This is only one example, though an extreme one, of the possible economies that might be effected by the use of clandestine agents, if only the agents could be got to the starting post in time. Yet communications with the field were never so close or so constant that SOE's staff could advise, or the more regular services' staff accept, the same degree of reliance on SOE's circuits as could be placed in artillery or aircrew. If gunners or bombers attacked a target, the commander who ordered the attack knew instantly that it had taken place, and air reconnaissance could normally reveal the results in hours; the weapons were familiar and the probable results were comparatively easy to estimate. From outside SOE, nothing inside it was familiar, and field commanders had no idea what to expect; SOE's staff were unlikely to tell them, or indeed to know, when or even whether a particular attack had been carried out, and it might take months to get accurate information about the results. No one can blame the staffs who stuck to the methods they knew, when such uncertainties faced them in the world of special operations. All the same, though it was often tricky to insert clandestine agents into France, to arm them, and to enable them to place their explosives on the precise spots where they would do most harm, it turned out feasible to inflict through the clandestine channels of SOE an amount of critical damage comparable to that inflicted on French industry and French transport by the much larger and enormously more expensive formations of the RAF and the USAAF. Difficult and delicate assessments are called for here which it has not been possible even to attempt in these pages; but again, the task does need to be pointed out for analytical historians to undertake later. Webster and Frankland have given a lead by remarking that 'The total effect of the [bomber] damage in France was not very important'.¹⁰ Anybody concerned in that favourite sport of military commentators, discussing future strategy, particularly needs to weigh up the relative advantages in manpower and in other resources of clandestine and of more formal methods of destroying potential enemy equipment.

The most useful of all the sabotage parties SOE sent to France was undoubtedly RF's ARMADA: a road engineer, an entrepreneur, a garage hand, and a student, who between them put out of action one of France's principal armament works, killed off a dozen tiresome Gestapo officials, and brought canal traffic between the Ruhr and the Mediterranean to a standstill at a critical period of the war when both for industrial and for naval purposes the Germans particularly needed it. If all the parties had had ARMADA's skill and nerve, a much more striking demonstration of the sabotage possibilities of clandestine warfare would have been produced, with a noticeable shortening of the war.

Yet what ARMADA did, excellently as it was done, might be described as normal work for subversive agents, carried out by an abnormally able team. F's STOCKBROKER introduced a genuinely new development: Rée's scheme of blackmailing factory owners into arranging the sabotage of their own plants, lest they be worse damaged by bombing. It was a misfortune of war that this system was unavailable till the air staffs were set on sending great coveys of Halifaxes and Lancasters nightly along that road to Calvary from which so many never returned. Bomber command frequently lost in a night more men than F section lost in the entire war; once it lost in a night more people than F section ever sent to France. The command's total of dead¹¹ was more than four times as great as SOE's total strength. How much greater were its useful achievements?

Anyone can see that bombers in those days could make bigger holes in the ground than agents could; but nobody sensible believes that big holes in the ground are necessarily of military value – this was one of the principal lessons of the land fighting of 1916–17, which a generation later was gaining general acceptance. As Rheam taught everybody who passed through his school, an adequate small bomb placed on the right spot was not only cheaper but better than a big one even if the big one was dropped on the right factory. The big charge might do much more damage and yet leave the factory still in production, because the damage was inessential; while one so small that its bang was hardly more than a loud pop might bring rows of workshops to a dead stand. Appendix G provides a few instances of Rheam's principles in application; they are worth attention from people who have worked on more usual bomb damage assessments.

Comparisons between the direct results of SOE's and the air forces' demolitions are interesting and obscure enough; questions arising from their indirect results are more interesting and more obscure still. For SOE in France, German morale was an indirect target: that is, the force was never specifically instructed to set about destroying it, in the way that bomber command was ordered to attack it by the Casablanca directive.¹² Yet the end result of SOE's as of other operations in France was to break the Germans' will to fight there. SOE's influence in this respect was inestimable, in the exact as well as the loose sense; it was both great, and incapable of precise

assessment. Indeed the steady sapping of enemy morale through carefully timed sabotage exploits was probably in a few important spheres more productive of results than was the wholesale devastation of his cities. Little of SOE's work in France could affect home morale in Germany; and yet a good deal of it could make an impact on the German war-making machine, by lowering the combativeness of the people who were supposed to run it. Air bombardment sometimes stiffens the will to fight it is intended to weaken; the English found in 1940–41, like the Catalans in 1936–37 or the Germans in 1943–44, that the survivors of materially devastating attacks get exhilaration and a sense of achievement from remaining at work. Besides, anti-aircraft defences are at least noisy, and give the groundlings the impression that someone is hitting back. But there are no noisy defences against sabotage; on the contrary, the incessant controls that are needed in any attempt to keep it in check are bound to be tiresome and may become exasperating; and while ordinary people complain at the delays, people in the know are depressed at the need for them. Once more or less open guerilla fighting breaks out, the morale of an occupying army may actually improve, because there may at last be something definite to hit back at; till it breaks out, occupying forces' morale is a useful target.

There is no doubt that the French communist party, acting through its militant wing the FTP, did a great deal of work towards sapping it, through the assassination of individual German uniformed officers and men. Useful as this policy of terrorism was in making the Germans jumpy, it undoubtedly – indeed, deliberately – attracted severe reprisals, usually wreaked on the neighbourhood where the killing had taken place and not on the men who had done the job. This did not worry the communists, who believed that they were thus 'precipitating a revolutionary situation', a jargon term carrying conviction to them alone. Many of SOE's sabotage coups were unnerving to German morale in a more sophisticated way, less prodigal of lives. Several times over, SOE's agents were able to render useless, by the judicious application of a few pounds of plastic, several weeks or even months of endeavour by the Germans or their underlings. When for instance STOCKBROKER had managed to destroy a critical piece of machinery in the Peugeot tank turret factory at Sochaux, and a replacement had been delivered after months of special effort by the Germans, the same circuit managed to destroy it while it was actually waiting to be unloaded from a truck in the factory yard; and all the replacement work had to be gone through again. Just as the Dunlop tyre factory at Montluçon had got back into production at the end of April 1944 after an air raid in September 1943, two pounds of plastic applied by STATIONER brought it again to a complete standstill. Two days after a petrol refinery in the Pas de Calais switched over from producing petrol for French civilians to producing it for the German army, FARMER burnt it out. This sort of pinprick, repeated often enough, succeeded in maddening the German occupation authorities. The best joint tribute to the

successes of the communists, of the gaullists, and of SOE in exasperating the Germans in this way is to be found in the notorious rigidity of the orders issued over and over again by the occupying authorities in their futile attempts to suppress what they denounced as 'terrorism'.

Yet sporadic terrorism, manifested in occasional acts of violence, was never SOE's principal task. The systematic outbursts of sabotage that greeted OVERLORD all over France were of great direct tactical help to the invasion, as had been intended ever since 1940. Undoubtedly, SOE did exceptionally well in this field; plans to assist OVERLORD and DRAGOON turned out not only successful, but much more successful than anybody had dared to hope. Not only did the forces of French resistance, acting with SOE's weapons and under SOE's general direction, produce more than a thousand railway cuts in France in a week, nearly two thousand in three weeks; they produced and maintained railway stoppages at an even greater rate than the air forces were able to do. In Belgium the story was the same. A few repetitions may be worth while. PIMENTO for instance claimed that after 6 June 1944 no train left Marseilles for Lyons without being derailed at least once by a PIMENTO team until the whole route had been freed. In the German Seventh Army area, where the bulk of the Normandy fighting took place, more of the rail cuts noted by the army staff in July and August were attributed to 'terrorists' than to air action. Aably assisted from inside by PTT employees, resisters were able to put nearly all the main telephone cables in France out of action on D-day or just after it; and one of the five German signals regiments in France, the one round Orleans attended to by Southgate's successors Maingard and Pearl Witherington and by Henquet and Fucs, never got its telephone cables back into action before it withdrew to Germany. An important advantage of forcing the enemy off the telephone was that much intelligence could be gleaned from his activity by wireless.

The decisive influence exercised by SOE on the fighting in France was not however the tactical one of disrupting enemy rail and telephone communications, nor even the tactical one of disrupting so extensively his movements by road; there was a main strategic gain, which was secured after OVERLORD began. Churchill had minuted back in January that 'It is to my mind very unwise to make plans on the basis of Hitler being defeated in 1944. The possibility of his gaining a victory in France cannot be excluded. The hazards of battle are very great. The reserves of the enemy are capable of being thrown from point to point with great facility.'¹³ By June this was no longer true. Thanks to SOE's success in raising hundreds of secret forces of lightly armed infantry scattered all over the country, the enemy could no longer rely on control of his own rear areas or his lines of communication with his base. The seventeen-day delay imposed by a dozen circuits from George Starr's WHEELWRIGHT in the south to Claude de Baissac's SCIENTIST in the north on the SS armoured division summoned from Toulouse on D + 1 to take part in the Normandy battle, the armoured division that got from the

Russian front to Strasbourg in a week and a day, and then took twenty-three days more to fight its way through to the formal battle-front at Caen, illustrate both the tactical importance of the delays imposed by resistance and their more important strategic significance. All the Germans' ammunition and reinforcements and most of their food had to come up to the fighting fronts across hundreds of miles of territory infested by resisters, most of whom had been trained and practically all of whom had been armed by SOE. Traffic to the front, by road and rail alike, was liable at any moment and at almost any point to be cut by methods that might take anything from five minutes to five months to repair. All things considered, this eminently desirable result had not been dearly bought. The whole strength of all the sections operating into France, and of a due proportion of the signallers, aircrew, RAF ground staff, packers, tailors, forgers, coders, typists, instructors, staff officers that backed them did not amount to three brigades; the front-line strength of agents actually deployed did not amount to one. Yet the effort they produced was certainly not less than that of half a dozen divisions, of three brigades each; and the Germans devoted eight – admittedly about the worst eight – of their sixty-odd divisions in France to the attempt to hold down their rear areas while OVERLORD was going on.

No one will ever be able to draw up a precise balance-sheet for this account; but a few contemporary opinions of people liable to be well informed are worth considering. Eisenhower himself wrote to Gubbins on 31 May 1945:

Before the combined staff of Special Force Headquarters disperses I wish to express my appreciation of its high achievements.

Since I assumed the Supreme Command in January 1944, until the present day, its work has been marked by patient and far-sighted planning, flexible adaptation to the operational requirements of Supreme Headquarters, and efficient executive action during operations. In no previous war, and in no other theatre during this war, have resistance forces been so closely harnessed to the main military effort.

While no final assessment of the operational value of resistance action has yet been completed, I consider that the disruption of enemy rail communications, the harassing of German road moves and the continual and increasing strain placed on the German war economy and internal security services throughout occupied Europe by the organized forces of resistance, played a very considerable part in our complete and final victory ...

The combination of certain sections of your two organizations, first established as Special Force Headquarters under the joint command of Brigadier Mockler-Ferryman and Colonel Haskell, was the means by which these resistance forces were so ably organized, supplied and directed. Particular credit must be due to those responsible for communications with occupied territory. I am also aware of the care with which each

individual country was studied and organized, and of the excellent work carried out in training, documenting, briefing and dispatching agents. The supply to agents and resistance groups in the field, moreover, could only have reached such proportions during the summer of 1944 through outstanding efficiency on the part of the supply and air liaison staffs. Finally, I must express my great admiration for the brave and often spectacular exploits of the agents and special groups under control of Special Force Headquarters.¹⁴

It is impossible to overlook the contrast with NEPTUNE'S ground force commander. Resistance is barely mentioned in either of the volumes in which Montgomery recounts the triumphs that, but for resistance, would not have been so easily won.¹⁵

Maitland Wilson, the other supreme allied commander operating across France, was as forthcoming in praise as Eisenhower, and though briefer more precise. Talking to Brooks Richards after DRAGOON was over about the value to it of the resistance troops who supported it, he 'unofficially estimated that the existence of this force reduced the fighting efficiency of the Wehrmacht in southern France to forty per cent at the moment of the DRAGOON landing operations'.¹⁶ This estimate, as Brooks Richards justly remarked, transcended all the shortcomings of the FFI; whose effectives in the former ZNO in August 1944 he put as high as 150,000.¹⁷

And when SHAEF did work out an assessment of the value of underground armies to land fighting on the continent, the conclusion was also striking; it was that 'without the organization, communications, material, training and leadership which SOE supplied, ... "resistance" would have been of no military value'.¹⁸ This substantial report summarized the main SOE achievements in France: fostering the French will to resist, keeping the enemy's attention taut, sapping 'his confidence, disrupting his communications – especially by telephone and rail, and forcing 'extensive and intricate detours' on his reinforcements 'at a crucial time', so that his troops reached the formal battlefield 'in a state of extreme disorganization and exhaustion'. 'A substantial contribution', they concluded, had been made to the AEF's victory by the resistance that had in many cases been guided and supported by SOE.¹⁹

All these victories by and through resistance forces in France had a common basis: overwhelming popular support. As SOE and SAS found alike, work got much harder eastward of the linguistic frontier of Alsace; wherever and whenever less than nineteen-twentieths of the mass of the population favoured the allies whole-heartedly, subversive activity became sticky, or dangerous, or downright impossible. The friendliness of the bulk of the French people in July and August 1944 derived from several sources. Among them were the more and more nightmarish quality of the German occupation, with its shortages, controls, arrests, deportations, atrocities; the

run of allied victories, presaging an early end to the nightmare; and the personalities of the great allied leaders, Churchill, Roosevelt, Stalin, beside whom the French by now saw de Gaulle standing as an equal. More personal motives, of hope or honour or self-interest, counted for a good deal. And undoubtedly the presence and example of SOE's agents counted for much. The allied propaganda services, led by PWE the successor to the old SOI, had by this time helped the French to regain the conviction that France must be independent and free; EMFFI's agents on the spot, the successors to SO2, with the indispensable help of the RAF and USAAF special duty crews, provided the means to attain this desirable end.

Although in the course of their work of beating the Germans the British had built up in France large funds of popular support, these funds had been built up by SOE, with which the Foreign Office had not always found itself able to agree. In 1947 Duff Cooper urged Ernest Bevin, who had himself signed SOE's death warrant on lines Eden had laid down in 1945, to renew friendly relations with France, and Bevin signed at Dunkirk on the seventh anniversary of the evacuation a fifty-year treaty of Anglo-French amity of which the significance has been overlaid by the general run of international politics since. More use might have been made of French goodwill that has wilted with time.

Yet when the alliance broke Hitler Great Britain no longer played a predominant role in it; and it is worth looking in conclusion at the attitudes to the gaullist movement of her two senior partners. The government of the United States took a view of French politics between the fall of France and the invasion of North Africa which diverged so sharply from that of the British that it caused severe disturbance in Anglo-American relations. The state department went further than the Foreign Office in treating the Vichy government as an independent power: Roosevelt's ambassador in Vichy, Admiral Leahy, was a personal friend of the President's in direct contact with him, and the two of them were able to pursue a vichysois policy of their own.²⁰ For naval reasons, Roosevelt regarded amity with Pétain as indispensable; the Americans took over at this time the nervousness about hostile submarine bases on the north-west African coast that had obsessed the British Admiralty since the invention of the submarine. The Americans were profoundly distrustful of de Gaulle from the start; their distrust was deepened by the eccentricities and indiscretions of some of his supporters in New York, who brought little credit to his cause. While anxious as usual to avoid the direct possession of overseas territories, the Americans found themselves toying in 1941 with vague ideas of extending the zone of United States influence into French North Africa, and Robert Murphy their consul-general there, no particular lover of Britain, established a considerable network of American agents who did much to prepare TORCH. The military success of TORCH was notable, but from the American point of view the operation came perilously near a complete political failure; of their two white hopes, Darlan was soon

assassinated and Giraud turned out not to be of the calibre required. He held firm to loyalties to Pétain and the doomed Vichy regime; such opinions were never going to set the Seine on fire.

Yet most Americans in positions of importance, from Roosevelt downwards, remained distrustful of de Gaulle. Various reasons for this have been imputed to them at the time and since by anti-American writers of various political complexions. Some have maintained that what the Americans had against de Gaulle was that his movement seemed too revolutionary, so that making friends with him was too like making friends with communism. This is a curious doctrine to hold about the country which was doing so much at the time to equip communist Russia with weapons and vehicles for fighting the Germans. All sorts of business reasons have also been suggested to account for this American coldness. The plain truth is that the Americans mistrusted generals in politics: they saw too many in Latin America to have many illusions about what generals in politics were likely to stand for. Giraud they hoped they could manage; at least he was affable. But they suspected from de Gaulle's frequently glacial manner – the manner which he felt he had to put on in order to preserve the dignity of the France he felt he represented – that like most generals he was an aristocrat at heart.

The Russians, the other major partners in the wartime alliance, at first took the same view of de Gaulle as the French communist party; indeed there is no reason to believe that the PCF under Thorez and Duclos had any official views that were not the views of Moscow. But the concept of de Gaulle as the tool of English bankers was soon laid aside; on Moscow's orders, the French communists came to support him warmly; and in the end the PCF attempted to take over the whole of the resistance movement of which its postwar propaganda has sought to suggest, in the teeth of the evidence, it was throughout the guiding element. In practice the gaullists and the French communists each made use of the others for their own purposes: each thought they could climb to power on the others' backs, and neither group ever properly controlled the other.

Here was one more point where SOE, the RAF, and the BCRA performed, perhaps inadvertently, a service useful to French liberty. Had it not been for them, the French communists might have tried to seize power, using men trained in the FTP. The PCF was widely feared at the end of the fighting in France; but that moment was unpropitious for a left-wing rising, since substantial American and British forces were on French territory, and the red army was far away. Yet when the war's end brought American and British, but not Russian, demobilisation, a coup of the type that succeeded in Czechoslovakia in 1948 might have been tried. As it was, SOE had provided arms and training for anti-communist as well as communist resistance groups; this made a communist attempt possible, but prevented a simple communist walk-over. And Jules Moch, a strong socialist who understood French history, countered the communist bid for power in 1947–48 by a

series of deft administrative strokes, applied through loyal subordinates in the refurbished traditional machinery of government. Other French politicians were thus afforded a further chance to show whether they could run a free society. It was also thanks – *inter alia* – to much past help from SOE that: this modern Cincinnatus was waiting in the wings at Colombey-les-Deux-Eglises to take over in 1958, as it became clear that at that time, without his guidance, they could not.

Appendices

Appendix A:

Sources

(I) ARCHIVES

Toynbee quotes Hancock's remark to a conference in Holland in the late forties 'that the volume of official documents produced by the United Kingdom Government and its agencies during the six war years, 1939–45, equalled, in cubic content, the volume of all previous archives of the United Kingdom and of its constituent kingdoms England and Scotland that had survived down to the date of the outbreak of war'.¹ But only a few pebbles in this mountain pile of documentation were contributed by SOE; for unless a secret service remains secret, it cannot do its work. As it has to remain secret, it ought not to keep any sort of records in the field. Even at its home base, security risks are not needlessly multiplied by putting more than the necessary minimum on paper. One obstacle to the historian of any secret service is therefore inherent in his subject-matter: the traces left for him to study are likely to be few.

In the case of this service there are several more. One is the problem of definition: SOE's boundaries were fluid, and it is not always easy to tell whether a particular operation was the responsibility of SOE or of some other authority, British or allied. Again, some degree of suspicion is prudent among the papers of such an ephemeral wartime organization as SOE. A few falsified papers may indeed be on file, but only a few; forgery on a large scale would have given trouble quite incommensurate with any object it could attain. This at least can be said about the files that survive: they were in a state of authentic confusion, and are often hard to reconcile with each other; occasionally a single file is self-contradictory. Hardly any two SOE files agree, for instance, about the exact date an agent went to the field; though Air Ministry files can often provide it.

Another difficulty derives from SOE's administrative system, or rather lack of it. The Baker Street headquarters had to be set up in such a higgledy-piggledy way, at such a moment of mixed elation and despair, and with so

haphazard a staff and a starting organization, that it had none of the routine appurtenances of an ordinary department of state, like a central registry and filing system. Security married with haste to beget filing by country sections or even smaller sub-divisions – F, RF, DF and EU/P sections, the JEDBURGHs, and EMFFI all kept their papers in separate places, classified on individual plans. An attempt to launch a central registry was made near the end of the war, so late in the day that it created quite as much chaos as it dispelled, and was abandoned: not before a substantial proportion of all the files had been re-registered on a new system quite unlike the previous ones, in which many cognate files remained. As the organization was wound up, some of the files were roughly weeded by staff officers who had helped to complete them, and took some care to throw away only the least useful papers. At this stage, or even earlier, the entire archive of MASSINGHAM's AMF section was burnt. The quantity that remained has three times been heavily reduced, once wholly by accident. A fire broke out in Baker Street early in 1946, and a great many important files are said to have been burnt before it was got under control; though here again there is a conflict of evidence, and there is good reason to believe that most of the papers destroyed were – even if numerous – of trivial importance only; though among them were also several files of particular interest to security, about how various agents had come to be arrested.² After SOE's demise, shortage of space more than once compelled the storing authority to turn some inexperienced clerks on to those that survived, with orders to effect a sizeable reduction; which was made, at a price to history. For France, many of the files on particular circuits and operations, almost all the messages exchanged with the field, most of the training files, and some important papers on the early development of SOE have thus disappeared. Still worse for present purposes, all F section's files were divided into two groups during this clearance; and the group that was kept, presumably because it was the smaller, was the group that contained the less interesting and less important papers. Almost all the section's circuit files have vanished. And thirdly the surviving files have been subjected to a steady process of attrition, sometimes extending to the destruction of files shortly before they were needed for the present book. I would therefore hesitate before adopting the view of a well qualified reader of the originals that SOE's papers are any longer 'certainly the best single source of material in the world for the history of European resistance'.³

And of course time has passed. It was not till November 1960 that I was introduced to the subject, of which my own war service at Combined Operations and SAS headquarters had given me no more than a glimmering. By then the survivors' ranks had thinned, and memories that might have helped an earlier historian had weakened with time. When JUDEX collected more active memories at the close of operations in France many exaggerated claims were made; more have been made since. All in all, there has been full scope for the scepticism any historian must carry in his mental baggage.

Yet evidence enough has survived to fill some hundreds of pages, and a few words about its nature are needed. They have to be prefaced by a note on papers that survive, but were unavailable to me.

Forty years ago I was not allowed to see any of the papers of SOE's financial directorate, which lay under a ban; now removed – they are to go public shortly, with the rest of SOE's headquarter files. The last ripple of the storms that convulsed SOE and its secret naval rivals during the war had not then quite subsided, and I had no access to Admiralty papers; that gap has been fully covered by Sir Brooks Richards's *Secret Flotillas*. He mentions (his pages 121–2) the landing of a woman NKVD agent on the Breton coast for the ROTE KAPELLE organization, something else I have not tried to follow up; nor have I seen papers on deception planning.

Lastly, I have had trouble finding out what was happening 'on the other side of the hill'. Presumably massive interrogations of captured German security officers were made at the end of the war, but I have seen few of them that bore on special operations in France. This obstacle, imposed to some extent at least by my ignorance of where to look for a way round it, has occasionally presented real difficulties; particularly in constructing chapter x on the worst mistakes.

The papers of SOE used to be regarded as permanently closed; a rule changed under the Waldegrave initiative of the early nineteen-nineties. The eighth of them that has survived is in process of transfer to the Public Record Office at Kew; all the surviving operational files that bear on France are there already, listed in a PRO pamphlet, *SOE Operations in Western Europe* (Kew, 1998). The personal files, on which much of the work above is based, are still on their way through the official laundry, but should be available by 2004.

So far as SOE's own papers are concerned, their evidential value varies widely; almost all are in typescript; and points of interest to the London staff predominate in what remains. The most readily accessible volumes, the bound section histories and war diaries, are top copy typescripts, deceptively easy to handle; for they are of course secondary sources, based on the more authentic data that may or may not have survived on record in grubbier and less meticulously ordered files; they are moreover uneven in quality. Thackthwaite's history of RF section is strongly prejudiced, but always interesting; and Hutchison has corrected in manuscript some of the most prejudiced passages. Buckmaster's notes on F section are much thinner. The war diary is a source of deteriorating value as the war goes on: the twelve monthly volumes for 1941 seem to have been compiled close to the events they chronicle, but by the middle of 1942 the diarist had become swamped. Country section diaries took over on 1 July; but F's petered out by the end of the year and RF's before D-day. After the war an effort was made to reconstruct country section war diaries from the telegrams, but dropped in favour of demobilising the diarists, and the telegrams were burned. Particular mention needs to be made of one other specially useful source.

Whenever an agent returned from a spell in France, he was interrogated by SOE's security staff; partly to make sure that he was still on the allied side, partly to test out the security of his companions in the field, and partly to discover lessons useful to future agents. Lavish use of these interrogations has been made; for many circuits no better evidence is available.

Of other departments' papers I have seen little; though I must make special mention of the chiefs of staffs' papers and of the special duty squadrons' operational record books, both of which have been among the most valuable sources I have seen.

I have made hardly any use of foreign archives, as the book was prepared in secrecy. The Special Collections Branch of the US National Archives and Records Service was kind enough to make a few useful captured German documents available; these are referred to in notes above as 'Washington files'. I had the advantage of hearing M. Henri Michel, head of the French official investigators into resistance history, at a number of international conferences on his subject; but to my keen regret have hardly been able to make any use of his extensive files. That choice was neither mine nor his; it arose necessarily from the conditions I had to work in.

There is one gap in this book, remediable by younger historians with the patience to penetrate the zareba that defends French archives. Soon – too soon – before this edition had to go to press, the Service Historique de l'Armée de Terre at Vincennes alerted me to the release of the papers of Colonel Dewavrin's BCRA, at 10 R 1204–1350 and 10 R 1481–1497; visible *sous dérogation*, that is, every individual carton must be cleared with the ministry of defence before it is handed over for research. The same service holds the surviving resistance archives for each department in France. The files for the Corrèze and the Haute Vienne make no mention of the event in resistance history currently best known to the British public, the arrest of Violette Szabo.

My access to former staff and agents of SOE was severely limited: till it had been decided that this pilot study was to appear, much importance was attached to keeping the author out of the way of interested parties. Once the decision to publish had been made, more than a year after the bulk of the book had been completed, it seemed more important to publish as soon as possible than to make perfectionist attempts to polish and re-polish a tale that in many ways is bound to remain craggy and imperfect. I would have liked to talk to all the survivors; but owed it to them; and still more to their dead companions, to get something into print to show that the dead deserve honour, and that SOE's effort was not made in vain.

(II) BOOKS

Henri Michel's *Bibliographie critique de la résistance* did not appear till the first edition of this book was in galley proof. Michel's work will be an indispensable

tool for all future serious students of French resistance history; I would myself have done well to read many more of the books he discusses before I began to write. For lack of precise information about SOE's role, he does not attempt any comprehensive listing of books on his subject in English; some of those best known in England he leaves out altogether. This is a reflection on these books' historical value rather than on his quality as a bibliographer.

No attempt is made here to match his work, in quality or in quantity; but it may help readers to judge such bias as I have accumulated from my reading to see the brief assessments below. As I said at the start, I have tried to avoid bias altogether; though my work with SAS in 1944 strengthened my belief in the military value of armed action behind the main battlefields. And the character of the English books on this subject is quite extraordinary enough to deserve remark.

The undoubtedly dramatic character of SOE's work in France, that unrelenting secret struggle of many hundreds of men and women against the Gestapo, has attracted many authors. Unfortunately, for lack of enough authentic material many of the resulting books are good thrillers, but bad history. Some books by former agents have been honestly written, and their evidential value is high; Cowburn's *No Cloak, No Dagger* and Millar's *Maquis* might be picked out for standing the test of verification by official sources particularly well. In other cases authors, even when they had themselves taken part in what went on, have not always found it possible to keep to the unvarnished truth. A sort of declension can be observed: from minor inaccuracies due to misinformation, or brought in to heighten the tone; through material foisted on authors by unscrupulous ex-agents of both sides protecting or inflating their own reputations; major imaginative revisions superimposed on the facts; and material printed in direct contradiction of statements made by those in a position to know; down to pieces of downright fiction elaborately disguised as fact.

No author can be wholly dispassionate, and several people have written on this subject with their emotions deeply engaged; with good reason. But strong emotion handicaps historians. On the evidence of their own books, some people unable to see any good in SOE have been in contact with sources that could have indicated the contrary to them, had they been able to open their minds enough to listen. Others *per contra* have implied in print that all was well when they certainly knew it was not.

No useful purpose is served by putting into a book list books which confuse the issue, instead of widening knowledge. I have therefore left out several titles, some of them only too well known: their evidential value is nil. They testify to zeal, but do not spread wisdom.

Books in English are published in London, books in French in Paris, unless otherwise noted.

- ALANBROOKE, *War Diaries 1939–1945* (Weidenfeld and Nicholson 2001), indispensable background.
- ANDREW, C. M., *Secret Service* (Heinemann 1985) puts SOE in its place.
— ed. *Intelligence and National Security*, now the leading academic quarterly on the subject.
- ANON. *La Résistance dans le pays de Montbéliard et la défense du Lomont* (Vernier, Pont-de-Roide, n.d. [1945]). A short honest pamphlet on maquis fighting south of Belfort.
- A[PPLEYARD], J. E., *Geoffrey* (Blandford Press 1946). Short life of Geoffrey Appleyard by his father, saying much of his exploits in West Africa and nothing of the binding of prisoners.
- ARON, Robert, *De Gaulle before Paris* (K, HARE, Putnam 1962). and *De Gaulle Triumphant*, (1964). A long military history by a gaullist civilian. *Les grands dossiers de l'histoire contemporaine* (Perrin 1962), a collection of essays, does not live up to its title.
- ASTIER DE LA VIGERIE, Emmanuel d', *Seven Times Seven Days* (tr. HARE, Humphrey, MacGibbon & Kee 1958). Uses a poet's insight and a radical's temper to convey the atmospheres of clandestine life, the inanities of politics at Algiers, and the disillusion of victory. *Les dieux et les hommes* (Julliard 1952). Recounts his efforts to persuade Churchill to arm the resistance in 1944. *De la chute à la libération de Paris* (Gallimard 1965). Useful summary of occupation, with valuable documents.
- ASTLEY, J. B., *The Inner Circle* (Hutchinson 1961). Valuable on MIR; and see WILKINSON.
- AUBRAC, Lucie, tr. BIEBER, K., *Outwitting the Gestapo* (University of Nebraska Press 1993), a daring war autobiography.
- AVON, Earl of, *The Eden Memoirs: ii The Reckoning* (Cassell 1965). Defends Eden's wartime career with little reference to SOE.
- BABINGTON SMITH, Constance, *Evidence in Camera* (Chatto 1957). Summary of development of photographic intelligence; no direct references to SOE.
- BARDOUX, Jacques, *La Délivrance de Paris* (Fayard 1958) shows how an anti-Pétainist senator, grandfather to a future president of the Republic, spent the last year of occupation.
- BAUDOT, Maurice, *L'opinion publique sous l'occupation* (Presses Universitaires de France 1960). Extrapolates lucidly from the author's wartime experiences in the Norman department of the Eure.
- BEAUVOIR, Simone de, *The Mandarins* (tr. FRIEDMAN, L. M. 1957). Depicts in a novel the state to which occupation, resistance, and liberation had reduced the intelligentsia of the French left.
- BELL, P. M. H., *France and Britain 1940–1994* (Longman 1997) puts the war in its historic context.
- BENTWICH, Norman, *I Understand the Risks* (Gollancz 1950). Describes the war service of refugees from nazism; passages on SOE slight.

- 'BERGERET' [i.e. LOUPIAS] and GRÉGOIRE, Herman, *Messages Personnels* (Bière, Bordeaux 1945). Straightforward account of resistance in the Dordogne.
- BERNARD, H., CHEVALLAZ, G. A., GHEYSSENS, R., LAUNAY, J. DE, *Les dossiers de la seconde guerre mondiale* (Marabout Université, Verviers 1964), useful introduction for students.
- BERTHON, Simon, *Allies at War* (HarperCollins 2001), book of a television series, recounts the wartime relations of Churchill, de Gaulle and Roosevelt.
- BINNEY, Marcus, *The Women Who Lived for Danger* (Hodder & Stoughton 2002), a popular account of ten of SOE's women agents.
- BLEICHER, Hugo, *Colonel Henri's Story* (ed. BORCHERS, E., and ed. and tr. COLVIN, Ian; Kimber 1954). Variegated and sometimes revealing account of Abwehr work in France, includes versions of unrecorded conversations.
- BOURBON, F. Xavier C. M. A. J., Prince de, *Les accords secrets franco-anglais de décembre 1940* (Plon 1949), Expounds the existence of an unwritten gentlemen's agreement between Vichy and London.
- BOURDET, Claude, *L'aventure incertaine* (Stock 1975), valuable memoirs by a leading resister, have little to say about SOE.
- BROME, Vincent, *The Way Back* (Cassell 1957), a life of Guérisse (Pat) crammed with anecdotes about underground working conditions; not based on official sources.
- BUCKMASTER, M. J., *Specially Employed* (Batchworth 1952), is prefaced by the remark that 'I do not claim that the incidents described in these pages are completely factually accurate'. Quite so. *They fought alone* (Odhams 1958) is not claimed as accurate either.
- BURNEY, Christopher, *The Dungeon Democracy* (Heinemann 1945). Analyses Buchenwald's place in European history. *Solitary confinement* (Macmillan 1952, second edition 1961). Describes his eighteen months in Fresnes. Both remarkable.
- BUTLER, Ewan, *Amateur Agent* (Harrap 1963). Useful on training system and for conveying flavour of SOE.
- CALMETTE, Arthur, *L'O.C.M.* (Presses Universitaires de France 1961). History of the *Organisation civile et militaire*, useful and clear.
- CAMUS, Albert, *The Rebel* (tr. BOWER, A., Hamilton 1953). Acute criticisms by the editor of *Combat* of nazi and marxist doctrines of revolution, and a sketch of his own.
- CARRÉ, Mathilde-Lily, *I Was the Cat* (tr. SAVILL, Mervyn, Four Square 1961). *Victoire* the double agent's autobiography; frankness alternating with evasions.
- CAUTE, David, *Communism and the French Intellectuals 1914–1960* (Deutsch 1965). A keen analysis of theoretical developments.
- CHEVALLAZ, see BERNARD.
- CHURCHILL, Peter, *Of their Own Choice* (Hodder 1952). *Duel of Wits* (Hodder 1957). *The Spirit in the Cage* (Hodder 1954). Readable, revealing, and reasonably accurate reports of his first mission to France; of his three

- later missions; and of his captivity. *By moonlight* (Hale 1958), a novel about the Glières.
- CHURCHILL, Winston, *The Second World War* (6v., Cassell 1948–54). Still the best guide to the conduct of the non-clandestine war by the British; hardly refers directly to SOE. *Secret session speeches* (ed. EADE, C, Cassell 1946). See also GILBERT, STAFFORD.
- COBBAN, Alfred, *A History of Modern France: iii France of the Republics* (Cape 1965), an English survey of French political history.
- COLLINS, Larry, and LAPIERRE, Dominique, *Is Paris Burning?* (Gollancz 1965). Accomplished journalists' reconstruction of liberation of Paris, mainly based on recollections long after the event.
- COOKRIDGE, E. H., *They Came from the Sky* (Heinemann 1965). Reconstructed adventures of Cammaerts, Landes, and Rée.
- COOPER A. DUFF, *Old Men Forget* (Hart-Davis 1953). Autobiography of British ambassador to CFLN in 1944 and to France in 1944–7; revealing difficulties between Churchill and de Gaulle and the diplomatic manners of both.
- COOPER, Lady Diana, *Trumpets from the Steep* (Hart-Davis 1960), concludes with two evocative chapters on her work in Algiers and Paris.
- CORDIER, Daniel, *Jean Moulin* (3v so far out of a projected six, J.-C. Lattès 1990–3), impeccable, massive biography by Moulin's assistant in the field for the last eleven months of his life.
- , *La République des Catacombes* (Gallimard 1999), called in jest by the author 'mon Moulin portatif' as it is only a thousand pages long, analyses Moulin's career in resistance and the tragedy of Caluire.
- COWBURN, Benjamin, *No Cloak, No Dagger* (Jarrolds 1960). A short, clear, discreet, and vivid account of some of TINKER'S experiences.
- CRAVEN, W. R., and CATE, J. L., *The Army Air Forces in World War II*, iii (Chicago 1951), an official history, includes a chapter on USAAF aid to resistance.
- CREMIEUX-BRILHAC, J.-L., *La France libre* (Gallimard, 1996). The leading account.
- CROFT, Andrew, *A Talent for Adventure* (Hanley Swan: SPA 1991), modest autobiography of a lively hero.
- CZERNIAWSKI, Roman Garby-, *The Big Network* (Ronald 1961). The leader of the INTERALLIÉ intelligence circuit's own account of its nature and work; numerous necessary corrections to the books on *La Chatte*, Mme Carré.
- DALTON, Hugh, *Hitler's War* (Penguin 1940), peppery statement of his views on European affairs, published before SOE existed. *The fateful years* (Muller 1957). Includes a chapter on SOE's origins and early development.
- PIMLOTT, Ben, ed. *The Second World War Diary of Hugh Dalton* (Cape 1986) explains his dislike of Grand. And see PIMLOTT.
- DANSETTE, Adrien, *Histoire de la libération de Paris* (Fayard 1946). Vivid and

- telling account compiled on the spot soon after the event. I have used a revised edition (1958).
- DEAR, I. C. B., and FOOT, M. R. D., *The Oxford Companion to World War II* (2 ed., Oxford: University Press 2001), mistitled but comprehensive.
- DEWAVRIN, André, ed. J.-L. CREMIEUX-BRILHAC, *Colonel Passy* (Odile Jacob 2000), three volumes of his memoirs (1947–51) rolled into one with invaluable notes and introduction.
- DODDS-PARKER, [Sir] Douglas, *Setting Europe Ablaze* (Windlesham: Springwood Books 1983), valuable on SOE's origins.
- DORMER, Hugh, *Hugh Dormer's Diaries* (Cape 1947). Plain narrative.
- DOURLEIN, Peter, *Inside North Pole* (tr. RENIER, F. G., and CLIFF, Anne, Kimber 1953). Victim's account of the Abwehr coup in Holland. Includes chapters on SOE training and escape lines.
- DOUZOU, I., ed. *Souvenirs inédits d'Yvon Morandat* (IHTP, 1994), useful sketches.
- DUKE, Madelaine, *No passport* (Evans 1957). Sketches the anti-fascist career of 'Jan Felix' [Jeschke], with chapters on his career in DF section.
- ECCLES, David and Sybil, *By Safe Hand* (The Bodley Head 1983), letters exchanged with his wife in 1939–42 by a British diplomat who happened to get on well both with Pétain and with Salazar.
- EDEN, see AVON.
- EHRMAN, John, *Grand Strategy V*, August 1943–September 1944 (HMSO 1956, in *History of the Second World War: United Kingdom military series*). Contains sparse but important references to the subject.
- ELLIOTT-BATEMAN, Michael, ed. *The Fourth Dimension of Warfare* (Manchester: Manchester University Press, 1970), includes essay by Gubbins.
- ELLIS, L. F., *Victory in the West*, vol. 1 (HMSO 1962). Official military history; sketchy on role of special forces.
- European Resistance Movements 1939–1945* (Pergamon 1960 and 1964) report respectively the proceedings of the resistance historians' conferences at Liège in 1958 and at Milan in 1961; the first in several languages, the second part in French and part in English. Apart from some important summaries by Henri Michel, these volumes are more of polemical than of historical interest. A third, rather meatier, volume from the Oxford conference of 1962 is in the press.
- FAIRBAIRN, W. E., and WALBRIDGE, D. N., *Silent Killing* (Faber 1942) includes elements of unarmed combat and knife encounters.
- FARRAN, Roy, *Winged Dagger* (Collins 1948), by an SAS squadron commander; includes a vivid account of WALLACE.
- FITZSIMONS, Peter, *Nancy Wake* (HarperCollins 2002), by an Australian admiral.
- FOOT, M. R. D., *Resistance* (Eyre Methuen 1976), analysis of European resistance to nazism; now rather dated.
- , *Six Faces of Courage* (new ed. forthcoming, Barnsley: Pen & Sword, 2003), covers Moulin, Peulevé and Gerson briefly.
- , *SOE: an outline history* (4 ed., Pimlico 1999), originally book of a television

- series in 1984.
- , *SOE in the Low Countries* (St Ermin's Press 2001), official history of SOE's disasters in Holland and Belgium. And see DEAR, MACKENZIE
- , and LANGLEY, J. M., *MI 9* (Boston: Little, Brown 1980) covers the British escape service.
- Foreign Relations of the United States of America*, 1943, ii, *Europe* (Washington, Department of State 1964). Shows strength of Roosevelt's dislike of de Gaulle.
- FORESTER, C. S., *The Nightmare* (Joseph 1954). A fictionalised account by a master storyteller, based on the attested facts, of SOE's enemies in the SS.
- FRANKLAND, see WEBSTER.
- FULLER, see OVERTON FULLER.
- FRENAY, Henri, tr. HOFSTADTER, Dan, *The Night will end* (Abelard 1976), detailed memoirs by the founder of COMBAT.
- FUNK, Arthur L., *Charles de Gaulle: the crucial years 1943–1944* (Norman, Oklahoma 1959). Useful political sketch by an academic American.
- , *Hidden Ally* (Greenwood Press 1992), a superb account of the integration of resistance forces with the American troops advancing from the DRAGOON landings in 1944.
- GARNETT, David, *The Secret History of PWE* (St Ermin's Press 2002), in-house history completed 1947, graded secret till 1998; full and frank.
- GAULLE, Charles de, *The Edge of the Sword* (1932; tr. Gerard HOPKINS, Faber 1960), A short essay on the nature of war and politics, written in high spirits with high ideals, *Vers l'armée de métier* (Levrault 1934). Sets out views on armoured warfare far in advance of French or British official thinking at the time. *Appels et discours 1940–1944* (n.p. 1944, published clandestinely), a useful collection.
- GAULLE, Charles de, ed. J.-L. CREMIEUX-BRILHAC *Mémoires* (Gallimard 2000) combines *Mémoires de Guerre* and *Mémoires d'Espoir* in a single volume; admirable notes; superb prose, glancing references to SOE.
- GHEYSENS, see BERNARD.
- GILBERT, Sir Martin, *Finest Hour* and *Road to Victory* (Heinemann 1985–86), part of Churchill's official biography, sparse on secret services.
- GILDEA, Robert, *Marianne in Chains* (Macmillan 2002), detailed account of life under nazi occupation, as seen through the local archives of the lower Loire valley: for those who wrote them, most resisters were a nuisance.
- GIRAUD, General H. H., *Mes Evasions* (Julliard 1946). Traveller's tales.
- GISKES, H. J., *London Calling North Pole* (tr. Kimber 1953). Responsible officer's account of the successful German measures to counter SOE in Holland.
- GOLDSMITH, John, *Accidental Agent* (Leo Cooper 1971), straight account.
- GOSSE, Lucienne, *René Gosse 1883–1943* (Plon 1962). Useful on resistance in the Dauphiné.
- GRANET, Marie, *Défense de la France* (Presses Universitaires de France 1960). History of the resistance movement of the same name.

- GRANET, Marie, and MICHEL, Henri, *Combat* (same 1959), ditto.
- GRÉGOIRE, see BERGERET.
- GRINNELL-MILNE, Duncan, *The Triumph of Integrity* (Bodley Head 1961). A panegyric life of General de Gaulle.
- GUBBINS, Sir C. McV., *Resistance Movements in the War*, JRUSI, xciii, 210–223, May 1948, useful outline; and see ELLIOTT-BATEMAN; HAUKELID; WILKINSON.
- GUÉRISSE, see BROME.
- GUETZEVIĆ, see MICHEL.
- GUILLAUME, Paul, *L'abbé Émile Pasty, prêtre et soldat* (Baule (Loiret), Comité Abbé Pasty, 1946). A short and simple account of the life and betrayal of a PROSPER sub-agent who died in prison; little good to say of SOE. *Les martyrs de la Résistance en Sologne* (Orleans, Lodde 1945?). A pamphlet recounting atrocities involving the death of nearly fifty young Frenchmen. *La Sologne au temps de l'héroïsme et de la trahison*. (Orleans, Imprimerie Nouvelle 1950). Remarkably accurate account of PROSPER'S collapse, embedded in much local material.
- HARRISON, D. I., *These Men are Dangerous* (Cassell 1956). An SAS troop commander's view of the war; passages on co-operation with the maquis.
- HAUKELID, Knut, *Skis against the Atom* (Kimber 1954). Recounts a decisive SOE coup in Norway; introductory sketch of the nature of SOE by Gubbins.
- HEILBRUNN Otto, *Partisan Warfare* (Alien & Unwin 1962). Treatise on theory of guerilla; tends, in passing, to undervalue resistance movements.
- HESLOP, Richard, *Xavier* (Hart-Davis 1970), straight account.
- HINSLEY, Sir F. H., *et al.*, *British Intelligence in the Second World War* (3v in 4, HMSO 1979–88), deals mainly with the decipher service.
- and SIMKINS, C. A. G., *Security and Counter-Intelligence* (HMSO 1990), the fourth volume in Hinsley's series, little reference to SOE.
- HOARE, Sir Samuel (Lord TEMPLEWOOD), *Ambassador on Special Mission* (Collins 1946). Recounts his service in Madrid.
- HOLLIS, see LEASOR.
- HOSTACHE, René, *Le Conseil national de la Résistance* (Presses Universitaires de France 1958). Sound account of the political and military institutions of resistance in France.
- HOWARD, Sir Michael, *Strategic Deception* (HMSO 1990), the fifth volume in Hinsley's series; decisive.
- HOWARTH, Patrick, *Special Operations* (Routledge 1955). Reprints chapters from books on SOE, including six relevant ones.
- , *Undercover* (Routledge & Kegan Paul 1980), characters from SOE, includes a long chapter on France.
- HYTIER, Adrienne Doris, *Two Years of French Foreign Policy: Vichy 1940–1942* (Paris, Droz 1958). A massive survey from an impartially hostile angle.
- INAYAT KHAN, see OVERTON FULLER.
- INTERNATIONAL MILITARY TRIBUNAL, see NUREMBERG TRIAL.

- JESCHKE, see DUKE
- KEDWARD, Roderick, *In Search of the Maquis* (Oxford: University Press, 1994), seminal.
- KEDWARD, Roderick, and AUSTIN, Roger, *Vichy France and the Resistance* (Croom Helm 1985), proceedings of an Anglo-Irish conference at Sussex university in 1984 on the state of research into the subject.
- KERSHAW, Ian, *Hitler* (2 vols, Allen Lane, 1998, 2000), all we need to know about SOE's worst-enemy.
- KIM, Jacques, *La Libération de Paris* (OPG 1945). A lively pamphlet of photographs.
- KRAMER, Rita, *Flames in the Field* (Michael Joseph 1995), sympathetic study of the four SOE women agents murdered at Natzweiler.
- LABRIC, Roger, *Robert Benoist champion du monde* (Ediota 1946), information about agent's motor racing career; brief and romanticised account of his work in resistance.
- LANGELAAN, George, *Knights of the Floating Silk* (Hutchinson 1959). A well-written agent's war autobiography.
- LANGER, William L., *Our Vichy Gamble* (New York, Knopf 1947). A diplomatic historian's account of American policy towards Vichy France in 1940–42, based on state department archives and much other inside information.
- LAPIERRE, see COLLINS.
- LAUNAY, DE, see BERNARD.
- LASKA, Vera, ed. *Women in the Resistance and in the Holocaust* (Greenwood Press 1983), eyewitness accounts, often harrowing.
- LARROQUE, Hervé, *Pauline* (Lamotte-Beuvron, Edition Par Exemple 1996), conversations with Henri and Pearl Cornioley (née Witherington).
- LEAHY, William D., *I Was There* (Gollancz 1950). War autobiography of US ambassador to Vichy; little relevant.
- LEASOR, James, and HOLLIS, Sir Leslie, *War at the Top* (Joseph 1959). Describes part of the British chiefs of staff's contribution to the war, references to SOE slight; some confusion with PWE.
- LE CHÊNE, Evelyn, *Watch for me by Moonlight* (Eyre Methuen 1973), wartime career of Boiteux, later Burdett.
- LEPROUX, Marc, *Nous, les terroristes* (2 vols, Solar, Monte Carlo 1947). A full illustrated account of the activities of a *section spéciale de sabotage* round Angoulême with wider general application.
- LEVERKUEHN, Paul, *German Military Intelligence* (tr. STEVENS, R. H., and FITZGIBBON, Constantine; Weidenfeld & Nicolson 1954). A straightforward, popular summary by a former Abwehr officer of his service's work.
- Livre d'Or de l'Amicale Action* (ORI 1953). Includes a summary of RF's operations and the names and addresses of several hundred surviving agents and sub-agents, as well as notes on a score of the eminent dead.
- LIVRY-LEVEL, Philippe, *Missions dans la RAF* (Caen, Ozanne 1951). A vivid personal account of the work of 161 squadron; and see RÉMY.

- LODWICK, John, *The Filibusters* (Methuen 1946). Lively participant's sketch of uniformed work behind German lines by British troops.
- , *Bid the Soldiers Shoot* (Heinemann 1958). A frivolous and entertaining war autobiography.
- LORAIN, Pierre, ed. KAHN, David, *Secret Warfare* (Orbis 1983), first published in Paris in 1972; an admirable account of SOE's weapons and W/T equipment, fully illustrated.
- MCCALLUM, R. B., *England and France* (Hamish Hamilton 1944). An Oxford don's view of the state of Anglo-French relations during the war.
- MCCUE, Paul, *SAS Operation Bulbasket* (Leo Cooper 1996), model investigation of SAS party working near Poitiers.
- MCLUSKEY, Revd. J. F., *Parachute Padre* (Collins 1947). A participant's account of 1 SAS in HOUNDSWORTH.
- MACKENZIE, W. J. M., ed. FOOT, M. R. D., *The Secret History of SOE* (St Ermin's Press 2000), virtual in-house history, completed 1948, graded secret till 1998; a gold-mine.
- MALRAUX, see TODD.
- MARKS, Leo, *Between Silk and Cyanide* (HarperCollins, 1998), an uncomfortable account of SOE's coding arrangements.
- MARNHAM, Patrick, *Jean Moulin* (John Murray 2000). In this hostile biography, Marnham takes the line the Moulin has been over-praised by his admirers, and seeks to puncture the balloon; even doubting the suicide attempt.
- MARSHALL, Bruce, *The White Rabbit* (Evans 1952). A gruesome and mainly authentic sketch of Yeo-Thomas's career in SOE, prepared with the agent's help.
- MARTELLI, George, *Agent Extraordinary* (Collins 1960). Recounts the almost miraculous adventures of Michel Hollard's intelligence *réseau* AGIR.
- MASSON, Madeleine, *Christine* (Hamish Hamilton 1973) on Christine Granville.
- MENGIN, Robert, *No Laurels for de Gaulle* (Michael Joseph 1966), recollections of an anti-gaullist French naval officer who stayed in London 1940–2; thought Buckmaster headed SOE.
- MICHEL, Henri, *Histoire de la Résistance* (PUF 1950). Brief introductory sketch. *Les mouvements clandestins en Europe, 1938–1945* (PUF 1961), the same. *Les courants de pensée dans la Résistance* (Presses Universitaires de France 1962), a mine of information about the history as well as the thought of resistance. *Histoire de la France Libre* (PUF 1963), another brief introduction; *Jean Moulin l'unificateur* (Hachette 1964), an excellent biography; and *Bibliographie critique de la Résistance* (SEVPEN 1964), indispensable. *Vichy Année 40* (Robert Laffont 1966) examines the Vichy regime's first six months with an impartial eye. *Paris allemand* (Albin Michel 1981) establishes the facts of occupation and submission; *Paris résistant* (same 1982), the companion volume, shows how talk turned to action, and action to success.
- MICHEL, Henri and GUETZEVIC, Mirkine, *Idées politiques et sociales de la résistance* (PUF 1954). Useful discussion and text; and see GRANET, Marie.

- MILLAR, George, *Horned Pigeon* (Heinemann 1946), *Maquis* (Heinemann 1945; 2 ed., Pan 1956). A clear, intense picture of life in occupied France, as seen first by an escaper and then by an SOE organizer.
- , *Road to Resistance* (The Bodley Head, 1979), explains how he got into SOE.
- MINNEY, R. J., *Carve Her Name with Pride* (Newnes 1956), Popular illustrated life of Violette Szabo, based partly on conversations with her parents and her friends.
- MINSHALL, Merlin, *Guilt-edged* (Bachman & Turner 1975), lively war autobiography by one of the originals of James Bond.
- MOCKERS, Michel, *Maquis SS 4* (Issoudun, Laboureur 1945). A participant's detailed account of the fighting in Berry.
- MOORE, Bob, *Resistance in Western Europe* (Oxford: Berg 2000), useful reading lists.
- MOULIN, Laure, *Jean Moulin* (Presses de la Cité 1969), masses of family and official detail, prefaced by Malraux' speech, 19 December 1964, when Moulin's supposed ashes reached the Pantheon.
- NEWTON brothers, see THOMAS, Jack.
- NICHOLAS, Elizabeth, *Death Be Not Proud* (Cresset Press 1958). Recounts the fate of seven women agents, allegedly killed through the penetration of the PROSPER circuit; painful reading, as a sensitive author gradually discovers underlying horrors in secret activities. Severe strictures on F section, some of them just.
- NOGUERES, Henri, *et al.*, *Histoire de la Résistance en France* (5v, Robert Laffont 1967–81), as seen by well-informed members of civilian resistance, inclined to the republican left; covers intelligence as well as subversion; relies heavily on first ed. of this book, seldom citing it except in disagreement.
- NUREMBERG TRIAL, i.e. *The Trial of German Major War Criminals: Proceedings of the International Military Tribunal Sitting at Nuremberg, 20 November 1945–1 October 1946* (23 vols, HMSO 1946–52). Melancholy but important evidence on German organization and methods for combating resistance; particularly in vol. v.
- OTTAWAY, Susan, *Violette Szabo* (Barnsley, Leo Cooper 2002), a good popular life, more accurate than Minney's.
- OUSBY, Ian, *France under Occupation* (Macmillan 2000). Valuable summary, covering politics, intelligence and sabotage.
- OVERTON FULLER, Jean, *Madeleine* (Gollancz 1952). A life of her friend Noor Inayat Khan. Many trivial inaccuracies hardly impair the dramatic force of the story. Much the same is true of *Born for Sacrifice* (Pan 1957), its paperback version. *The Starr Affair* (Gollancz 1954) presents J. A. R. Starr as a much-maligned innocent, victimized by F section to cover its own mistakes. Four books on Déricourt: *Double Wébs* (Putnam 1958). *Double Agent?* (Pan 1961), *Horoscope for a Double Agent* (Fowler 1961) and *Déricourt: The Chequered Spy* (Russell 1969). Accuracy variable.

- PARET, Peter, and SHY, John W., *Guerrillas in the 1960s* (Pall Mall 1962). An excellent introductory survey of the theory of irregular warfare.
- PARKER, G. E., *Black Scalpel* (Kimber 1968), vivid account by MARKSMAN's medical officer.
- PASSY, see DEWAVRIN
- PAWLEY, Margaret, *In Obedience to Instructions* (Barnsley: Leo Cooper, 1999), excellent on FANY cipher staff.
- PERRAULT, Gilles, *Le secret du Jour J* (Fayard 1964), assembles some gaudy stories about intelligence and cover operations bearing on the date of OVERLORD. As far as SOE at least is concerned, this book bears little relation to the facts and has slight evidential value.
- PIMLOTT, Ben, *Hugh Dalton* (Papermac 1986), a strong biography, not at its strongest on SOE. And see DALTON.
- PIQUET-WICKS, Eric, *Four in the Shadows* (Jarrolds 1957). Vivid, well-illustrated short lives of four distinguished Frenchmen killed in action: Jean Moulin, Scamaroni, Labit and Brossolette. Essentially true; colours touched up a little.
- POIRIER, Jacques, tr. BROWNJOHN, John, *The Giraffe has a Long Neck* (Leo Cooper 1995), useful details on AUTHOR and DIGGER circuits.
- REITLINGER, Gerald, *The SS: alibi of a nation* (Heinemann 1956). Depressingly accurate.
- RÉMY [i.e. RENAULT-ROULIER, Gilbert], *Comment meurt un réseau*, (Solar, Monte Carlo 1947). *Une affaire de trahison* (Solar, Monte Carlo 1947). *Les mains jointes* (same, 1948). *The Silent Company* (tr. SHEPHERD, L. C., Barker [1948]). *Courage and Fear* (same tr., Barker 1950). *Portrait of a Spy* (same tr., Barker 1955). *Ten Steps to Hope* (tr. ORTZEN, Len, Barker 1960). These books provide an urban equivalent to Millar's *Maquis*. They vividly describe life in an underground movement. Though they deal only with an intelligence *réseau*, they illustrate the advantages and defects of all French clandestine work. One of them, *Une affaire de trahison*, illustrates also the habitual sadism that agents who fell into Germans hands encountered.
- RÉMY [i.e. RENAULT-ROULIER, Gilbert], and LIVRY-LEVEL, Phillippe, *The Gates Burst Open* (tr. SEARCH, Pamela, Arco 1955). An account of the air raid on Amiens prison on 18 February 1944 (JERICHO) with much incidental information on French resistance.
- RENDIER, Capitaine Martin, *Quatre ans dans l'ombre* (Condom: Bousquet, 1948), by a close assistant of George Starr, full of front-line detail.⁴
- RENOUVIN, Pierre, *Histoire des relations internationales VIII* (Hachette 1958), book two. The best general review.
- La Résistance et les Français*, proceedings of five major historians' conferences, held some fifty years after the end of of nazi occupation to explain the state of the subject: at Toulouse in 1993, J. M. GUILLON and P. LABORIE eds. *Mémoire et Histoire*; at Rennes in 1994, Jacqueline SAINCLIVIER and C. BOUGEARD eds. *Enjeux stratégiques et environnement moral* includes detail on

- Breton resistance and on Catholic affairs; at Brussels in 1994, R. FRANK and J. GOTOVITCH eds. *La Résistance et les Européens du Nord* discusses relations with the British, and sociological aspects; at Besançon in 1995, F. MARCOT ed. *Lutte armée et Maquis*, covers actual combat and is the most relevant to this book; and at Paris in 1995, L. DOUZOU, R. FRANK, D. PESCHANSKI and D. VEILLON, *Villes, centres et logiques de décision*.
- Revue d'histoire de la deuxième guerre mondiale* (since 1950). Long the leading learned journal on its subject.
- REYNAUD, Paul, *In the Thick of the Fight* (tr. LAMBERT, James D., Cassell 1955). Abridges his *Au coeur de la mêlée* (2v., Flammarion 1951). A strictly personal account.
- RICHARDS, [Sir F.] Brooks, *Secret Flotillas* (HMSO 1996), admirable detailed account of secret sea landings in France and in Tunisia.
- ROBERTSON, K. G. ed. *War, Resistance and Intelligence* (Barnsley; Pen and Sword 1999).
- ROCHESTER, Devereaux, *Full Moon to France* (Robert Hale 1978).
- ROSSI, A., *A Communist Party in Action* (tr. KENDALL, Willmoore, New Haven, Yale University Press, 1949). A fully informed and closely reasoned anti-communist account of the PCF's wartime structure.
- ROWAN, R. W., *The Story of the Secret Service* (Miles 1938). Long popular summary of pre-war state of the subject.
- RUBY, M., *F Section SOE* (Leo Cooper 1988).
- RUSSELL OF LIVERPOOL, Lord, *The Scourge of the Swastika* (Cassell 1954; Corgi re-issue 1960). Brings out the illegality, as well as the beastliness, of the Germans' treatment of people captured on special operations.
- RYAN, Cornelius, *The Longest Day* (Gollancz 1960). A popular account of D-day in Normandy; practically devoid of useful references to resistance.
- SALOMON, Ernst von, *The Captive* (tr. KIRKUP, James, Weidenfeld & Nicolson 1961). Historical novel about German prison conditions, 1925–50; some SOE agents in Buchenwald play a part.
- SCHNABEL, Reimund, *Macht ohne Moral* (Röderberg, Frankfurt-am-Main, 1957). Explains through several hundred pages of amply illustrated documents – with hardly a word of commentary – what the SS was and did. Unbearable; unforgettable.
- SEAMAN, Mark, *Bravest of the Brave* (Michael O'Mara 1997), a life of Yeoman Thomas, fuller and less moralistic than Marshall's. See also next item.
- , ed., *Secret Agent's Handbook of Special Devices* (Richmond, Surrey: PRO, 2000). An even more variegated collection than Lorain's, in form of illustrated stores catalogue.
- SERVAGNAT, P., *La Résistance et les FFI dans l'arrondissement d'Épernay* (La Chapelle de Montligeon 1946). Sound working sketch.
- SHIRER, William, *Rise and Fall of the Third Reich* (Secker 1960). Good general summary by an American observer.
- SOLTIKOW, Count Michael, *Die Katze* (Sternbucher, Hamburg 1956). An

- illustrated and fictionalised account of Mme Carré's war career; historical value minimal.
- Soustelle, Jacques, *Envers et contre tout* (2 vols, Laffont 1947–50). Inside stories of the BCRA and DGSS.
- Spears, Sir Edward, *Assignment to Catastrophe* (Heinemann, 2 vols, 1947), describes the origins of gaullist resistance in London.
- Stafford, David, *Britain and European Resistance 1940–1945* (2 edn Macmillan 1983), a valuable survey of SOE's relations with the Chiefs of Staff. *Churchill and Secret Service* (John Murray 1997) shows how Churchill's obsession with this subject began; *Secret Agent* (BBC Books, 2000), another television background book.
- Stead, P.J. *Second Bureau* (Evans 1959). Illustrated account of some non-gaullist resistance in France; mainly concerned with intelligence.
- Strawson, John, *History of the SAS Regiment* (Secker & Warburg 1984), much the soundest source in print.
- Sweet-Escott, Bickham, *Baker Street Irregular* (Methuen 1965). The first lengthy general survey of SOE by one of its senior staff.
- Szabo, see Minney, R.. J; Ottaway. S.
- Tanant, Pierre, *Vercors, Haut-lieu de France* (Arthaud, Grenoble 1948). Vivid illustrated account of this rising by the French chief of staff on the spot.
- Taylor, A. J. P., *English History 1914–1945* (Oxford University Press, 1965). This brilliant survey shows how little historians need archives. It discusses English wartime politics and strategy, but does not refer to SOE.
- Teissier du Cros, Janet, *Divided Loyalties* (Hamish Hamilton, 1962; Edinburgh: Canongate Classics, 1992). Sir Herbert Grierson's daughter describes the wartime life of a Scotswoman with a French husband in the Cevennes and in Paris; vivid accounts of civil turmoil.⁵
- Templewood, see Hoare.
- Thalmann, Rita, *La mise au pas* (Fayard 1991), an acute dissection of the German security system in France.
- Thomas, Jack, *No Banners* (Allen 1955). A long popular account of the resistance career and sufferings in prison of the Newton brothers; distinguished for honesty and modesty.
- Thornton, Willis, *The Liberation of Paris* (Hart-Davis 1963). Excellent photographs, little on SOE.
- Tickell, Jerrard, *Moon Squadron* (Wingate 1956). Chatty, vivid account of 138 Squadron; accurate in parts. *Odette* (Chapman & Hall 1949). A popular and partly fictionalised life of Mrs Sansom (*Lise*). Also accurate in parts. *Villa Mimosa* (Hodder 1960). Entertaining, strategically and tactically absurd, novel about SOE–CCO co-operation in 1944.
- Tillon, Charles, *FTP* (Julliard 1962). Strongly biased first-hand account by senior wartime commander.
- Todd, Olivier, *André Malraux: une vie* (Gallimard 2001), a long and detailed life of the novelist, brushes his relations with SOE aside as trivial.

Trial of German Major War Criminals, see NUREMBERG TRIAL.

VARILLON, Pierre, *Mers-el-Kébir* (Amiot-Dumont 1949). Maintains this battle only benefited the Germans. *Sabordage de la flotte à Toulon* (Amiot-Dumont 1954). A straightforward illustrated narrative.

VERITY, H. B., *We Landed by Moonlight* (Wilmslow: Air Data Publications 1994; first published by Ian Allan 1978), a masterly survey, by its commander in 1943, of the work for SOE of the Lysander flight of 161 Squadron, R.A.F.

VOMÉCOURT, Philippe de, *Who Lived to See the Day* (Hutchinson 1961). A colourful, sometimes exaggerated account of his activities and the development of resistance in central France; well illustrated.

WAKE, Nancy, *The White Mouse* (Melbourne: Macmillan 1985), autobiography; and see FITZSIMONS.

WALKER, David E., *Lunch with a Stranger* (Wingate 1957). Gives an entertaining picture of the frontier where SOE marched with PWE; useful on FORTITUDE.

WALTERS, Anne-Marie, *Moondrop to Gascony* (Macmillan 1946). Communicates vividly the hectic life of the maquis in 1944, with some pardonable exaggerations.

WARD, Dame Irene, M.P., *FANY Invicta* (Hutchinson 1955). Some of the history of the WTS concerns SOE with variable accuracy.

WEBB, A. M., ed., *The Natzweiler Trial* (Hodge 1949). Records the killing of four women couriers in depressingly vivid detail.

WEBSTER, Sir Charles, and FRANKLAND, A. Noble, *The Strategic Air Offensive, against Germany 1939–1945* (4 vols. 1961). Recounts the faults and the achievements of RAF bomber command; references to SOE slight.

WIGHTON Charles, *Pin-stripe Saboteur* (Odhams 1959). Wartime life of Jacques Weil; plenty of imaginative reconstructions.

WILKINSON, P. A., *Foreign Fields* (I. B. Tavis, 1997), admirable war autobiography.

—, and ASTLEY, J. B., *Gubbins and SOE* (Leo Cooper, 1993), indispensable.

WILMOT, Chester, *The Struggle for Europe* (Collins 1952). The few references to French resistance in this otherwise excellent book obscure its nature and much underestimate its importance.

WINTLE, Lieut-Col. A. D., MC, *The Last Englishman* (Michael Joseph 1968), an autobiography distilled by Alistair Revie from over a million words Wintle left on his death in 1966. No copy in British Library, Bodleian or Cambridge University library – all stolen.

WOODWARD, Sir E. Ll., *British Foreign Policy in the Second World War* (HMSO 1962). An official account based on the dispatches.

WRIGHT, Gordon, 'Reflections on the French Resistance (1940–1944)', *Political Science Quarterly*, xxvii, 336–49 (1962). Concentrates on resistance role of PCF.

WYNNE, Barry, *Count five and die* (Corgi 1959). There is nothing in the files to show that this is anything but fiction. *No Drums ... No Trumpets* (Barker

1961). On the MARIE-CLAIRE escape line, includes some details about F section's women agents in prison.

YEO-THOMAS, *see* MARSHALL; SEAMAN.

YOUNG, Gordon, *Cat with Two Faces* (Putnam 1957). Accurate account of Victoire (Mme Carré)'s career as a double agent. *In trust and treason* (Hulton 1959), an illustrated life of Suzanne Warengem, has plenty of information about escape lines and a little about SOE.

ZEMBSCH-SCHREVE, *Pierre Lalande Special Agent* (Barnsley: Leo Cooper 1996), vivid war autobiography.

Appendix B: Women agents sent into France by SOE

<i>Name and Field Name</i>	<i>Service</i>	<i>Circuit</i>	<i>Date and Method of Entry</i>	<i>Destiny</i>
(i) <i>F section</i>				
GERSON, Giliana, née BALMAGEDA (<i>none</i>)	none (Chilean)	DF	End May 1941, civil	Returned through Spain late June 1941.
HALL, Virginia (<i>Marié</i>) (1)	none (US)	HECKLER	End August 1941, civil	Returned over Pyrenees November 1942.
RUDELLAT, Yvonne née CERNEAU (<i>Jacqueline</i>)	FANY	PHYSICIAN (PROSPER)	July 1942, felucca	Died in Belsen, April 1945.
CHARLET, Blanche (<i>Christiane</i>)	FANY	VENTRILOQUIST	1 September 1942, felucca	Arrested, escaped from French prison, returned over Pyrenees
*BORREL, Andrée Raymonde (<i>Denise</i>)	FANY	PHYSICIAN (PROSPER)	24–25 September 1942, parachute	Executed at Natzweiler, July 1944.
BAISSAC, Lise de (<i>Odtile</i>) (1)	FANY	SCIENTIST	24–25 September 1942, parachute	Returned by Lysander, August 1943; now Mme VILLAMEUR
HERBERT, Mary (<i>Claudine</i>)	FANY	SCIENTIST	31 October 1942, felucca	Overrun by allies in France; later Mrs de BAISSAC
SANSOM, Odette, née BRAILLY (<i>Lise</i>)	FANY	SPINDLE	31 October 1942, felucca	Returned from Ravensbrück; married Peter CHURCHILL; later Mrs HALLOWES
LE CHENE, Marie-Thérèse (<i>Adèle</i>)	FANY	PLANE	31 October 1942, felucca	Returned by Hudson, August 1943

Appendix B continued

<i>Name and Field Name</i>	<i>Service</i>	<i>Circuit</i>	<i>Date and Method of Entry</i>	<i>Destiny</i>
NEARNE, Jacqueline (<i>Jacqueline</i>)	FANY	STATIONER	25 January 1943, parachute	Returned by Lysander April 1944
AGAZARIAN, Francine, née ANDRE (<i>Marguerite</i>)	FANY	PHYSICIAN (PROSPER)	17 March 1943, Lysander	Returned by Lysander, June 1943, later Mrs Gais
*AISNER, Juliette, née SIMART (<i>Cléire</i>)	FANY	FARRIER	14 May 1943, Lysander	Returned by Lysander, April 1944 as Mme BESNARD
LEIGH, Vera (<i>Simone</i>)	FANY	INVENTOR	14 May 1943, Lysander	Executed at Natzweiler, July 1944
INAYAT KHAN, Noor (<i>Madelaine</i>)	WAAF	CINEMA-PHONO	16 June 1943, Lysander	Executed at Dachau, September 1944
LEFORT, Cecily, née MACKENZIE (<i>Alice</i>)	WAAF	JOCKEY	16 June 1943, Lysander	Died or executed at Ravensbrück early 1945
ROWDEN, Diana (<i>Paulette</i>)	WAAF	ACROBAT/ STOCKBROKER	16 June 1943, Lysander	Executed at Natzweiler, July 1944
PLEWMAN, Eliane, née BROWNE-BARTROLI (<i>Gaby</i>)	FANY	MONK	13-14 August, parachute	Executed at Dachau, September 1944
GORMEAU, Yvonne, née BIESTERFELD (<i>Annette</i>)	WAAF	WHEELWRIGHT	22-23 August 1943, parachute	Overrun. Much later, Mrs FARROW
BEEKMAN, Yolande, née UNTERNAHRER (<i>Yvonne</i>)	WAAF	MUSICIAN	18-19 September 1943, Lysander	Executed at Dachau, September 1944
*WITHERINGTON, Pearl (<i>Marie</i>)	WAAF	STATIONER/ WRESTLER	22-23 September 1943, parachute	Overrun; now Mme CORNIOLEY

Appendix B *continued*

<i>Name and Field Name</i>	<i>Service</i>	<i>Circuit</i>	<i>Date and Method of Entry</i>	<i>Destiny</i>
ROCHESTER, Devereaux (<i>Elizabeth</i>)	None (US)	MARKSMAN	18 October 1943, Hudson	Overrun in French prison.
WALTERS, Anne-Marie (<i>Colette</i>)	WAAF	WHEELWRIGHT	4 January 1944, parachute	Returned over Pyrenees, August 1944; later Mme COMERT.
*DAMERMENT, Madeleine (<i>Solange</i>)	FANY	BRICKLAWER	29 February 1944; parachute	Arrested on landing; executed at Dachau, September 1944.
*BLOCH, Denise (<i>Ambroise</i>)	FANY	CLERGYMAN	2-3 March 1944, Lysander	Executed at Ravensbrück, early 1945.
NEARNE, Eileen (<i>Rose</i>)	FANY	WIZARD	2-3 March 1944, Lysander	Escaped from Markelberg; overrun in Germany.
BASEDEN, Yvonne (<i>Odette</i>)	WAAF	SCHOLAR	18 March 1944; parachute	Returned from Ravensbrück; now Mrs BURNEY.
HALL, Virginia (<i>Diane</i>) (2)	None (US)	SABOT	21 March 1944, motorboat to Brittany	Overrun; later Mrs GOILLOT.
O'SULLIVAN, Patricia Maureen (<i>Simone</i>)	WAAF	FIREMAN	22-23 March 1944, parachute	Overrun; now Mrs ALVEY.
*FONTAINE, Yvonne (<i>Mimi</i>)	FANY	MINISTER	25 March 1944, motorboat	Overrun; now Mme DUMONT.
ROLFE, Lilian (<i>Nadine</i>)	WAAF	HISTORIAN	5-6 April 1944, Lysander	Executed at Ravensbrück, early 1945.
SZABO, Violette, née BUSHELL (<i>Louise</i>) (1)	FANY	SALESMAN	5-6 April 1944, parachute	Returned by Lysander, 30 April 1944.

Appendix B continued

<i>Name and Field Name</i>	<i>Service</i>	<i>Circuit</i>	<i>Date and Method of Entry</i>	<i>Destiny</i>
BYCK, Muriel (<i>Violette</i>)	WAAF	VENTRILOQUIST	8–9 April 1944, parachute	Died of meningitis in France, May 1944.
BAISSAC, Lise de (<i>Marguerite</i>) (2)	FANY	SCIENTIST	9 April 1944, Lysander	Overrun. Now Mme VILLAMEUR.
WILEN, Odette, née SAR (<i>Sophie</i>)	FANY	LABOURER	11 April 1944, parachute	Returned over Pyrenees, August 1944; now Mme DE STRUGO.
*FIOCCA, Nancy, née WAKE (<i>Hélène</i>)	FANY	FREELANCE	29–30 April 1944, parachute	Overrun; now Mrs FORWARD.
LATOUR, Phyllis (<i>Geneviève</i>)	WAAF	SILVERSMITH	23–24 May 1944, parachute	Overrun.
KNIGHT, Marguerite (<i>Nicole</i>)	FANY	DONKEYMAN	6 May 1944, parachute	Overrun; now Mrs SMITH.
*LAVIGNE, Madeleine (<i>Isabelle</i>)	FANY	SILVERSMITH	23 May 1944, parachute	Overrun; died in Paris, February 1945.
BUTT, Sonia (<i>Blanche</i>)	WAAF	HEADMASTER	28 May 1944, parachute	Overrun; now Mrs D'ARTOIS.
SZABO, Violette, née BUSHELL (<i>Louise</i>) (2)	FANY	SALESMAN	7 June 1944, parachute	Executed at Ravensbrück, early 1945.
JULLIAN, Ginette (<i>Adèle</i>)	FANY	PERMIT	7 June 1944, parachute	Overrun near Chartres, August 1944; went south for further mission near Dijon; again overrun.
GRANVILLE, Christine, née de GYZICA (<i>Pauline</i>)	WAAF	JOCKEY	6–7 July 1944, parachute	Overrun; murdered in London 1952.

Appendix B continued

<i>Name and Field Name</i>	<i>Service</i>	<i>Circuit</i>	<i>Date and Method of Entry</i>	<i>Destiny</i>
		(ii) <i>RF</i> section		
*REDDE, Danielle (<i>Marocain</i>)	CAF ¹	[Lyons]	January 1944, parachute	Overrun.
PETTEJEAN, Marguerite (<i>Binette</i>)	None	CIRCONFERENCE	30 January 1944, parachute	Returned over Pyrenees, August 1944.
BOHEC, Jeanne (<i>Pinasse</i>)	None	FANTASSIN	29 February–1 March 1944, parachute	Overrun.
UNIENVILLE, Aïx d'(<i>Myrtil</i>)	CAF	ORONTE	31 March–1 April 1944, parachute	Arrested, escaped, overrun.
SOMERS, Marcelle (<i>Albanais</i>)	None	CONE	3–4 May 1944, Hudson	Overrun.
HEIM, A. Germaine (<i>Danubien</i>)	CAF	PÉRIMÈTRE	5–6 July 1944, parachute	Overrun.
GROS, Josiane, née SOMERS (<i>Vénitien</i>)	CAF	CONE	6–7 July 1944, parachute	Overrun.
GRUNER, Eugénie, née LE BERRE (<i>Bulgare</i>).	None	RECTANGLE	10–11 August 1944, Hudson	Overrun.
MARGILLY, Cecile de, née PICHARD (<i>Allese</i>)	CAF	[AD MR in region A]	11–12 August 1944, parachute	Overrun.
*GIANELLO, Marguerite (<i>Lance</i>)	None	? PÉRITOINE	1–2 September 1944, parachute	Overrun.
GORGE, Aïmée (<i>Hellène</i>)	None	?	11 September 1944, parachute	Overrun.

¹ CAF = Corps Auxiliaire Féminin, the French equivalent of the AFS.

Note: *Previously engaged in resistance work in France

Appendix C:

Supply

The supply system outlined in Chapter IV of the text deserves more detailed consideration than it is possible to give it, for the bulk of the evidence needed to assess it has disappeared. The greater part of F's wireless traffic with France was devoted to minutiae of supply; that is, the detailing of dropping zones and interminable specifications about what was to go to them and when. An officer much concerned with all this at the Baker Street end cherished for many years the memory that agents often seemed to ask for very queer objects to be dropped to them; yet in principle whatever they asked for was sent, on the one condition that it could be got onto an aircraft and off again. But practically all these multifarious details are lost to record.

In this sea of uncertainty, a few islands of fact are chartable.

Some are financial. A series of tables at the back of F section's history, compiled with some care at the end of the war by one of the section's staff, indicates that the section sent to the field – or raised there by loans from friendly business men – the following sums in francs:

TABLE VI: FRANCS SUPPLIED TO F SECTION AGENTS IN THE FIELD¹

<i>Year</i>	<i>Sent with F's air operations</i>	<i>Raised by loan</i>	<i>Sent by DF channels</i>	<i>Total</i>
1941	10,000,000	55,000	–	10,055,000
1942	25,000,000	6,733,000	2,120,000	33,853,000
1943	40,649,000	31,777,500	6,700,000	79,426,500
1944	241,298,000	24,074,000	12,966,000	278,338,000*
Total	316,947,000	62,639,500	21,786,000	401,672,500

Note: * Half this sum was provided by EMFFI.

Two million pounds was not an excessive sum to invest for the dividends the independent French section brought in.

EU/P's expenses were comparatively light, and were covered by the Polish government in London. I have seen no figures on DF's or AMF's expenses, but have no reason to believe they were heavy. Each member of a JEDBURGH team took 50,000 francs to the field with him, and each team commander took an extra 50,000; these sums were ample.

It was in RF section that the more lavish spending took place; but if totals were ever recorded they have vanished. Dewavrin has put down one interesting group of figures, giving Jean Moulin's expenditure as de Gaulle's delegate on dozens of named resistance groups, between mid-December 1942 and the end of the following May; they totalled nearly 70 million francs.² And the section history notes that between November 1943 and July 1944 as large a sum as 1,346,315,000 francs was dispatched by parachute to RF agents from English airfields. Not a centime went astray in the end, though twenty-five million francs of this sum were mislaid in Dorset Square for some weeks, and discovered in the end under a sack of secret waste, waiting their turn for the incinerator.³ MASSINGHAM dispatched 70,650,000 francs by air in the same period; losing a further 8,500,000 when the aircraft carrying them was wrecked.⁴ There was a fair amount of strong feeling among the French about the custody of these considerable sums; the great bulk of them was certainly laid out on supporting the resistance movements most likely to side with de Gaulle, but there is nothing in the anti-gaullist theory that the British – still less, the American – Treasury was subventing gaullism for some nefarious purpose by printing quantities of notes. All SOE's French currency was genuine.⁵

Money usually has to be accounted for; hence the fragments of ascertainable fact about money expended. In a secret organization, stores were less accountable; hence trouble for the historian.

No adequate records survive of supplies sent into France by sea. It is only clear that they were not extensive. The 'lardering' operations on the Breton coast can hardly have put more than a ton or two into the right hands; VAR's stores intake was practically confined to agents' personal baggage, wireless sets, and a few small arms for the circuit; CARTE only received two felucca-loads on the Riviera, and what if anything the *Casablanca* and other French submarines carried later cannot be discovered now. In any case, most of their stores work was done into Corsica, not onto the mainland. 125 tons were put into Breton and west coast ports in September 1944; by that time the clandestine war in France was nearly over.

A few details of these sea stores operations may be worth inserting. One of the many difficulties that hindered them was reception; but the trouble of getting a reception committee and a boat to the same place at the same time could be avoided by putting the stores in caches. This could most simply be done by waterproofing them and lowering them overside in lobster pots,

marked by the usual cork floats; a method tried by F section near the Ile de Batz late in December 1941, without useful result. The packages, water-proofed to last about three weeks, were not collected in time.⁶ F section had no better luck with an operation to the same area a year later: half a ton of weapons and explosives were concealed on the beach on 9 November 1942,⁷ but were never collected by the agents who should have called for them; a fisherman came on them accidentally next summer, and told the Germans. In the third and last of these 'lardering' operations, twelve containers of arms were hidden by an SOE naval party accompanied by an RF staff officer among the rocks on the Ile Guennoc, off the mouth of the Aberwrac'h, on the night of 3/4 April 1943; these were also found by fishermen, more patriotic ones this time, who took them to the mainland and distributed them round their friends.⁸ Apart from a few wireless sets and pistols, no more stores were landed by sea in north-west France till September 1944, when the fighting in France was almost over. Then at last the Helford flotilla could show its paces; some thirty tons of stores, most of them medical, were landed from fishing craft at St Michel-en-Grève, Bénodet, Lézardrieux, and Ushant. Two destroyers took 45 tons of stores and six French agents to Les Sables d'Olonne on 11/12 September, and another landed 50 tons of stores and 14 belated JEDBURGH agents at the same port on the 28/29th.⁹ The stores were of some assistance to the SHINOILE mission that organized the weak but willing French resistance units blockading the Germans who had stayed behind in St Nazaire and La Rochelle; and it is useless to inquire how much more good might have been done by massive deliveries earlier by sea, because such deliveries never turned out to be practicable.

Massive deliveries by air did in the end turn out possible; here the difficulty is not one of too few figures, but of too many. Several different sets of figures have been drawn up; all conflict. The following table (see page 422) may be taken as a rough guide, as near as we are now likely to get to the truth. It bears some uncertainties on the face of it; but at least it comes from a source likely to be reliable.¹⁰

Over 10,000 tons of stores, in fact, were put into France by air under SOE's auspices; though some three-fifths of the stores, and more than half of the 1,800-odd agents, did not reach French soil till after the Normandy battle had begun. What proportion of these stores were warlike it is no longer possible to say exactly; but the percentage was undoubtedly high, well over 80 and probably over 90. Equally it is impossible to say what proportion of them fell straight into enemy hands, or were captured before effective use could be made of them; though again, one thing is sure – the proportion was much lower. RF section for one worked on the 'completely arbitrary and empirical' percentage calculation that ten per cent of any month's load would soon be in enemy hands, that ten per cent would be lost, one way or another, in transit, and that twenty per cent would be immediately absorbed in current resistance activities; leaving sixty per cent of what had been sent

TABLE VII: AIR SUPPLY TO FRANCE

Date	Successful Sorties			Tonnage of Stores ¹			Agents ¹			
	From UK		Total approx.	From UK		From Medi- terranean	From UK		From Medi- terranean	Total
	RAF	USAAF		RAF	USAAF		RAF	USAAF		
1941	22	-	22	1.5	-	-	37	-	-	37
1942	93	-	93	23	-	-	155	-	-	155
Jan.-Mar. 1943	22	-	22	20	-	-	31	-	-	31
Apr.-June 1943	165	-	167	148	-	1	41	-	2	43
July-Sept. 1943	327	-	329	277	-	1	92	-	3	95
Oct.-Dec. 1943	101	-	107	133	-	6	50	-	4	54
Jan.-Mar. 1944	557	52	759	693	73	172	88	6	20 ⁺ ³	114 ⁺
Apr.-June 1944	748	521	1,969	1,162	733	794	88	76	96	260
July-Sept. 1944	1,644	1,336	4,030	3,223	1,925	1,100	258	263	474 ⁴	995
Totals	3,679	1,909	7,498	5,680.5	2,731	2,074	840	345	599 ⁺	1,784 ⁺

Notes: ¹ Figures for stores and agents carried into France include both parachute and pick-up operations.

² Division of Mediterranean sorties between RAF and USAAF unavailable.

³ Figures of agents sent from Mediterranean bases in January and February 1944 unavailable.

⁴ Including almost all the OGs.

available for subsequent operations. As the section's historian adds, 'It has not yet been possible to discover how near or how wide of the mark this figure was, nor is it ever likely to be.'¹¹

Nevertheless one other chartable territory is to be found hereabout. The source that provided the figures in the last table gives also the distribution, for aircraft based in England, of stores drops as between containers and packages; and this not wholly arid body of statistics is also worth setting out:

TABLE VIII: CONTAINER AND PACKAGE DROPS TO FRANCE¹²

	<i>Containers</i>		<i>Packages</i>	
	<i>RAF</i>	<i>USAAF</i>	<i>RAF</i>	<i>USAAF</i>
1941	9	–	11	–
1942	201	–	64	–
Jan.–Mar 1943	170	–	57	–
Apr.–June 1943	1,361	–	236	–
July–Sept. 1943	2,566	–	399	–
Oct.–Dec. 1943	1,202	–	263	–
Jan.–Mar 1944	6,096	619	1,676	228
Apr.–June 1943	12,188	4,151	2,828	2,359
July–Sept. 1944	29,932	15,423	4,591	7,642
Totals	53,725	20,193	10,125	10,229

Craven and Cate add a useful footnote to this by giving details of the numbers of containers dropped in the USAAF's daylight operations after D-day – numbers that are included in the table above: they were as follows:¹³

25 June	2,077
14 July	3,780
1 August	2,281 ¹⁴
9 September	810

There is a useful table, undated, compiled after the war by Charles W. Cowie, head of the statistical section of the Service Historique des Armées de Terre at Vincennes.¹⁵ The arms listed below were delivered to occupied France; the supply service clearly held the scales pretty evenly as between F and RF sections.

	<i>RF</i>	<i>F</i>	<i>AMF</i>
Kgs explosive	286,987	271,395	35,628
Stens	92,944	91,045	13,491
Brens	9,934	10,139	445
Rifles	63,473	53,999	9,858
Pistols	26,579	30,821	449
Hand grenades	313,407	362,008	47,216
Gammon grenades	56,245	49,177	8,408
Anti-tank mines	3,540	5,370	100
Anti-tank rifles	15	44	2
PIAT	498	660	48
Bazookas	904	1,536	
Mortars	185	41	59
Carbines	2,595	6,770	6
Marlins	576	1,316	1
Incendiaries	53,008	63,249	7,086

The same authority breaks these figures down further, department by department, for the benefit of local historians. The totals run to over 800,000 grenades and over 350,000 hand-held weapons besides almost 600,000 kilograms of explosive: a fair armament, even if the enemy collared a third of it.

One other thing is worth reporting to round off the story of air supply: the system of container loading that SOE found it had to adopt under pressure of time at the packing station. Some notes on this are in that invaluable though bulky saboteur's companion, Leproux;¹⁶ it may be more convenient to English readers to have the main loads set out here.¹⁷

STANDARD LOADS

1. LOAD A. 12 Containers

- 6 Brens plus 1,000 rounds per gun, with spares and 48 empty magazines.
- 36 Rifles plus 150 rounds per gun.
- 27 Stens plus 300 rounds per gun, 80 empty magazines and 16 loaders.
- 5 Pistols plus 50 rounds per gun.
- 40 Mills Grenades and Detonators.
- 12 Gammon Grenades with 18 lbs. P.E., Fuse and Adhesive Tape.
- 156 Field Dressings.
- 6,600 rounds 9 mm. Parabellum. 20 empty Sten Magazines.
- 3,168 rounds .303 Carton. 20 empty Bren Magazines.

For 15 containers add to the above:

- 145 lbs. Explosive and all accessories.
- 6,436 rounds .303 Carton. 40 empty Bren Magazines.
- 6,600 rounds 9 mm. Parabellum. 20 empty Sten Magazines.
- 228 Field Dressings.

For 18 *containers* add to the above:

6,436 rounds .303 Carton.	40 empty Bren Magazines.
6,600 rounds 9 mm. Parabellum.	20 empty Sten Magazines.
228 Field Dressings.	

For 24 *containers* double the quantity for 12 *containers*.

2. LOAD B. 12 Containers

9 Rifles plus 150 rounds per gun.	
11 Stens plus 300 rounds per gun, 55 empty magazines and 11 loaders.	
13,200 rounds 9 mm. Parabellum.	40 empty Sten Magazines.
22,176 rounds .303 Carton.	140 empty Bren Magazines.
660 Field Dressings.	
145 lbs. explosives with all accessories.	

For 15 *containers* add to the above:

6,436 rounds .303 Carton.	40 empty Bren Magazines.
6,600 rounds 9 mm. Parabellum.	20 empty Sten Magazines.
228 Field Dressings.	

For 18 *containers* add to the above:

6,436 rounds .303 Carton.	40 empty Bren Magazines.
6,600 rounds 9 mm. Parabellum.	20 empty Sten Magazines.
228 Field Dressings.	

For 24 *containers* double the quantity for 12 *containers*.

3. LOAD C. 12 Containers

19,800 rounds 9 mm. Parabellum.	60 empty Sten Magazines.
28,512 rounds .303 Carton.	180 empty Bren Magazines.
882 Field Dressings.	

For 15 *containers* add to the above:

6,600 rounds 9 mm. Parabellum.	20 empty Sten Magazines.
6,436 rounds .303 Carton.	40 empty Bren Magazines.
228 Field Dressings.	

For 18 *containers* add to the above:

6,600 rounds 9 mm. Parabellum.	20 empty Sten Magazines.
6,436 rounds .303 Carton.	40 empty Bren Magazines.
228 Field Dressings.	

For 24 *containers* double the quantity for 12 *containers*.

4. LOAD D. 12 Containers

8 Brens plus 1,000 rounds per gun.	64 empty magazines
9 Rifles plus 150 rounds per gun.	40 empty Bren Magazines
9,504 rounds .303 Carton,	
234 Field Dressings.	
145 lbs. explosive plus all accessories.	
4 Bazookas plus 14 Rockets per Bazooka.	
40 Bazooka Rockets.	

For *15 containers* add to the above:

3,168 rounds .303 Carton.	20 empty Bren Magazines.
78 Field Dressings.	
145 lbs. explosive plus all accessories.	
9 Rifles plus 150 rounds per gun.	

For *18 containers* add to the above;

6,436 rounds .303 Carton.	40 empty Bren Magazines.
156 Field Dressings.	
40 Bazooka Rockets.	

For *24 containers* double the quantity for *12 containers*.

NOTES

Piats, each weapon packed with 20 bombs, and 10 Gammon grenades were often sent in lieu of bazookas, and in the maquis areas the American .30 Carbines with 350 rounds per gun replaced the rifle whenever possible.

The Marlin 9 mm. S.M.G. similarly often took the place of the Sten.

The few empty corners in these loads might well be filled up by tricolour armbands, which were widely distributed by both SOE and SAS. They were intended to provide the 'distinctive badge or mark' required under the Hague convention to establish a combatant's right to combatant status if he fell into enemy hands. The suggestion was SOE's; it may have saved a few lives. Certainly it did a lot of good to distant maquisards' morale, by making them feel they belonged to the allied expeditionary forces.

Appendix D:

Notes for Pilots on Lysander and Hudson Pick-up Operations

by Wing Commander H. B. Verity, DSO, DFC¹

PREPARATION

By far the greatest amount of work you do to carry out a successful pick-up happens before you leave the ground. These notes will give you some idea of the drill I tried to adopt and may help you to form your own technique. Never get over-confident about your navigation of Lysander ops. Each operation should be prepared with as much care as your first, however experienced you may be.

CHOOSING YOUR ROUTE

2. *Air Transport Form.* Your ATF will give the exact pinpoint of your landing ground, worked out from signals from the field and marked on a map 1 in 80,000 or 1 in 50,000. Attached will be a P[hotographic] R[econnaissance] U[nit] photograph which will be helpful.

3. *Landmarks.* Having established exactly where your target is, have a look at the half million map and select a really good landmark nearby. This may be a river from which you approach the target. Check with the flak map that you will not be interfered with. Then you must work out a route, hopping from landmark to landmark, which will follow clear avenues on the flak map. Try to arrange for a really good landmark at each turning point, for example a coast or a big river. Finally, get your route approved by the Flight Commander.

PREPARATION OF MAPS

4. *Half million.* It is usual to make half million folding route map which will take you all the way to your target and back. If your target is within 2 hours

flying range, 50 miles on each side of the track should be enough. If, on the other hand, you are going down to Lyons or Angouleme, it would be wise to have a 100 miles on either side of the track. Fifty miles at each side can be turned back behind the map. When preparing this map, be careful to fold clear of important landmarks.

5. *Quarter million maps.* Take quarter million maps of almost the whole route on short trips and of parts of the route on long trips. They are invaluable for confirming a pinpoint which is doubtfully marked on the half million. Take a quarter million of the target area itself.

6. *Target maps.* Target maps can be compiled with quarter million on one side and a PRU photograph on the other. In some cases, the 50,000 map may also be attached, but the black 80,000 is very difficult to read in the air. Do not forget that the reception committee might not be there when you first arrive. It is useful to be able to identify the field positively, even if you have to locate a barn shown on the photograph.

7. *Diversion maps.* On every trip, however good the weather forecast, you should be prepared for a diversion when you come home. The wireless will not necessarily be working and you will feel an awful fool if you haven't the faintest idea of where to go or how to get there ...

8. *Gen cards.* Gen cards giving your flight plan data should be duplicated as a precaution against loss ... Besides your navigational data, you must carry the signals and beacons for your return.

9. *Spare maps.* Do not forget that maps sometimes get lost in the air. Not one of the maps you carry should be indispensable. You can generally find a scruffy old route map to carry with you as a spare.

10. *Learning your route.* You can quite easily spend two hours in an armchair reading your maps before you go. It is very much easier in the air if you have done most of your map reading on the ground. The technique for pre-reading a map is something like this: – first take your half million route map. Go through it systematically, following along your track. Note what landmarks you will see. Then study it to port and starboard of your track. Then study it with each of the other main types of landmark. Then re-read special parts of the route on a quarter million, and learn them up in the same way. Try to memorise the shapes of woods and the general way in which they are distributed over your map. Try to memorise any towns which you may see and the way in which other landmarks converge on them. Notice the way a coast or river runs, and the magnetic course of any given stretch.

11. *Loading of aircraft.* Three passengers are normally the maximum carried, but four have been carried without incident in the past. As you may well imagine, that means a squash. With either three or four, it is thought impracticable for them to put on parachutes or bale out. If four passengers are carried,

one goes on the floor, two on the seat, and one on the shelf. This is not recommended with heavy people.

12. *Luggage.* Of course, the heaviest luggage should go under the seat, nearest the centre of gravity. Small, important pieces of luggage, such as sacks of money, should go on the shelf, so that they are not left in the aeroplane by mistake. Mistrust the floor under the shelf, as it is difficult for passengers to find luggage which has slipped down towards the tail.

13. *Petrol.* The more petrol you take, the heavier your aeroplane will be for the landing and take-off; on the other hand, a very large margin of safety is recommended. You may well be kept waiting an hour or more in the target area by a reception committee that is late in turning up, or [have] to find yourself when you are lost, and you may need an hour's petrol when you get back to England to go somewhere you can land. You should have about two hours' spare petrol altogether.

14. *Emergency kit.* If you get stuck in the mud, it is useful to have in the aeroplane some civilian, clothes. Do not put these in the passengers' compartment or they may be slung out. A good place is in the starting handle locker. You should also carry a standard escape kit, some purses of French money, a gun or two, and a thermos flask of hot coffee or what you will. A small flask of brandy or whisky is useful if you have to swim for it, but *NOT* in the air. Empty your pockets of anything of interest to the Hun, but carry with you some small photographs of yourself in civilian clothes. These may be attached to false identity papers. In theory it is wise to wear clothes with no tailor's, laundry or personal marks. Change your linen before flying, as dirty shirts have a bad effect on wounds. The Lysander is a warm aeroplane, and I always wore a pair of shoes rather than flying boots. If you have to walk across the Pyrenees you might as well do it in comfort.

15. *Conclusion.* You have a hell of a lot to do to get an operation ready, but there is quite a lot of it you can do the day before. It never matters if you prepare the op and don't do it. You may go that way some day and somebody else can always use your maps. It is most important to start an op fresh, and a good idea to have a nap or two in the afternoon or evening before you take off. Finally, you get driven to your aeroplane in a smart American car with a beautiful FANY driver, cluttered up from head to toe with equipment and arms and kit of every description, rather like the White Knight, prepared for every emergency.

EXECUTION

16. The notes up to this point may be called the *preparation* of a pick-up operation. Now we come to the execution. The simplest form will be an

imaginary night, in which I will try to visualise some of the problems which may crop up and suggest methods of thinking out the answers.

BEFORE TAKE-OFF

17. You must make sure that the escorting officer for the agent knows the form. If he does not, you must attend to your agent yourself. Make sure that he knows how much luggage he is carrying and where it is stowed. He must know how to put on and operate parachutes, if carried, and helmets and microphones. He must try the working of the emergency warning lights. He must understand the procedure for turning about on the field. This is, briefly, for Lysanders, that one agent should stay in the aeroplane to hand out his own luggage and receive the luggage of the homecoming agent, before he himself hops out. In the rare case where the agent has night flying experience over the area in question, it may be of use to give him a map of the route. One operation failed when the pilot was very far off track and the agent, a highly experienced Air Force officer, knew perfectly well where he was but could not tell the pilot because the [intercom] was switched off.

RUNNING-UP

18. Your running up, of course, should be thorough. Test all your cockpit lights and landing lights before taxi-ing out.

CROSSING THE CHANNEL

19. One school of thought recommends crossing the Channel low down to approach the enemy coast below the [radar] screen. I am opposed to this, because of the danger of flak from the Royal Navy and from enemy convoys, besides which a heavily laden aeroplane will not climb very quickly to the height at which it is safest to cross the enemy coast ...

CROSSING THE ENEMY COAST

20. It is generally safer to cross the enemy coast as high as possible up to 8,000 ft. This gives you a general view of the lie of the coast and avoids the danger of light flak and machine gun fire which you might meet lower down. On the other hand, your pinpoint at the coast is of vital importance, for by it you gauge your wind and set your course for the interior along a safe route, so it may be necessary to fly along a much lower route than 8,000 ft. to see where you are in bad weather. Don't think that you will be safe off a flak area within four miles. I have been shot at fairly accurately by low angle heavy flak three miles off Dieppe at 2,000 ft., so, until you know where you are, it is not wise to make too close an investigation of the coastline. In this case you may identify the coast by flying parallel with it some miles out to sea. Notice the course which it follows and any general changes of direction which it takes. By applying these to your map you will generally find that

you must be at least on a certain length of coastline and, at best, at a definite point. When you know your position you may gaily climb above any low cloud there may be and strike into the interior on D[ead] R[eckoning]

MAP READING

21. As I indicated in the notes on the preparation of an op., most of your map reading must be done in a comfortable armchair before you take off, otherwise your maps will be of very little use to you in the air. But once in the air, don't forget that map reading must never take precedence over the DR and even when you decide to follow a definite feature you must check the course of this feature with your compass. The reason for this is that you may very well find a landmark on the ground which corresponds with a point on your map, but is not, in fact, that point. I once spent a miserable two hours near Lons-le-Saunier by confusing the village of Bletterans with the village of Louhans. If you look on the map at these two villages in broad daylight you will find little similarity, but on a dark night the lie of the streams, railways and roads have some points in common. So never have faith in one pinpoint until you have checked it with a second, or even a third, nearby. This is very easy. Supposing you think you are over X town: look at your map and you will find that five miles south of it there is a large wood, for example. Fly south, and if no wood exists you will know that it is not X town and you will have to think again. If the wood is there, check the shape of it with your quarter million map and the road detail surrounding the wood and this will probably confirm that it is X town. I said that you should check the course of any feature you may be following, because it is fearfully easy to think that you are on a given railway, for instance, when in fact you are not, but railways are easily identifiable by their course.

MAP READING DETAILS

22. It may be useful if I run over the various types of landmark and try to point out their advantages and their snags.

(a) *Water*

Water always shows up better than anything else, even in very poor light, if it lies between you and the source of the light. If the light is diffused by cloud, water may show up well in a large area, even beyond visibility. The best landmarks are, of course, the coast and the large rivers which should not be easily mistaken. ... Don't forget that seasonal fluctuations in flood and drought may alter the appearance of a river and that in some cases the land near a small stream may be flooded, giving it the appearance of a very large river. Another case where a stream may suggest a large river is when ground fog lies just along the valley, which from a distance is sometimes confusing. Lakes are rather tricky, especially if they are close to other lakes ...

(b) *Forests and Woods*

Forests and woods probably show up next best to water, especially from a height or in haze. Small woods are very easily confused, but the character of their distribution over a stretch of country will help you to identify the area. Large forests, however, are very good landmarks ... Woods may be particularly well identified just near the target by comparison with the target photograph.

(c) *Railways*

The next most useful type of landmark is the railway. Although a railway may not be very easily seen in itself, the lie of the track may be deduced from the contours of the land, because, of course, a railway does not tackle a very steep gradient. Sometimes a railway is given away by the glowing fire-box of an engine, by a row of blue lights (in the case of an electric railway) or by a line of smoke lying like a wisp of fog on a still night or a cluster of yellowish lights on a big junction or goods yard. As water, the railway track itself will gleam when it is between you and the moon. The great advantage of railways is that they are relatively few and far between and therefore less likely to be confused with each other. You will get to know the difference between main lines and subsidiary lines by the number of tracks and the tendency for main lines will be broad sweeps, while the subsidiary lines will follow tighter curves.

(d) *Roads*

Roads can be very confusing, because there are often many more on the ground than are marked on your map, especially a half million, and sometimes a subsidiary road shows up much better than a main road. However, a route nationale, lined with poplars and driving practically straight across the country, may be very useful, and you can find your way to a town or village by the way the roads converge on it. The area north of Orleans is very open and flat and one is tempted to rely too much on roads, but they are very confusing, for the reasons given above. In general terms it is wiser to use roads as a check on other landmarks rather than as main landmarks in themselves and very often a quarter million map will be more helpful in giving the appearance of a road than a half million. If roads, railways and streams are running parallel, you should always notice in which order they lie – running from north to south or east to west. The presence of a road may be indicated from a distance by the headlights of cars moving along.

(e) *Large towns*

Anything coming up on your track which looks like a large town or an industrial centre should be avoided on principle, in case there is flak there.

This is especially true if you are not sure just where you are. This is a pity, of course, because large towns are very good landmarks, but as with the coast, a town may be identified from a distance by flying round it out of range. There is very often a stream or river flowing through a town and naturally roads and railways approach it from well-defined directions. Sometimes a town – for example, Blois – is well distinguished by woods nearby. By intelligent use of these clues there should be little difficulty in guessing which town it is and then confirming it by consideration of detail. The same remarks apply to villages, but a village is not easily identified off its own bat. Neighbouring landmarks will generally identify it.

MAP READING POLICY

23. Map reading policy is divided into two parts, (a) anticipatory map reading and (b) finding your position when you don't know it.

(a) *Anticipatory map reading*

Anticipatory map reading is normal when you know your position roughly and are more or less on track. In two words you look at your map first and the ground afterwards. Look ahead of your position on the map, decide what the next good landmark will be and keep your eye open until it turns up. In practice, it is as well to look out for landmarks on your track, to port of your track and to starboard of your track and wait with an open mind for any of the three to turn up. When choosing a landmark of this sort, have a look round your map to see if there is anything else at all similar with which it might be confused.

(b) *Finding your position when you don't know it*

In this case you look at the ground first and your map afterwards. Assume that you fly on DR for a large part of your route, over fog or low cloud, and that when you reach better weather and can see the ground you have not the faintest idea where you are. On a still night your DR will prove to have been very accurate and on a windy night less accurate, but still the area in which you may be will be limited. Have faith in your DR and start using a small area of map where you should be on E[stimated] T[ime of] A[rival]. Find on the ground a noteworthy landmark, such as a railway junction, a forest or river, and circle that until you have found it on your map. Then, as I said before, check it with a second and even a third neighbouring landmark before you set course. If you find that you are still off track, it may be best to fly to your track at the nearest point before setting course again. If you try to be a clever boy and set a new course from your known position to your track at some distant point, you may get into trouble, but with experience you will learn how much you can trust your own arithmetic and navigational sense.

TARGET AREA PROCEDURE

24. On approaching the target area, fish out your target map, refresh your memory of the letters and do your cockpit drill. This involves switching on the fuselage tank, putting the signalling lamp to 'Morse', pushing down your arm rests, putting the mixture control back and generally waking yourself up. Don't be lured away from your navigation by the siren call of stray lights. You should aim to find the field without depending on lights or to find some positive landmark within two miles of the field from which you will see the light. If you don't see the light on ETA, circle and look for it. One operation was ruined because the pilot ran straight over the field twice but did not see the light because the signal was given directly beneath him and he failed to see it because he did not circle. Once you have seen the light, identify the letter positively. If the letter is not correct, or if there is any irregularity in the flare path, or if the field is not the one you expected, you are in *NO* circumstances to land. There have been cases when the Germans have tried to make a Lysander land, but where the pilot has got away with it by following this very strict rule. In one case where this rule was disobeyed, the pilot came home with thirty bullet holes in his aircraft and one in his neck, and only escaped with his life because he landed far from the flare path and took off again at once.² Experience has shown that a German ambush on the field will not open fire until the aeroplane attempts to take off, having landed. Their object is to get you alive to get the gen, so don't be tricked into a sense of security if you are not shot at from the field before landing. I repeat, the entire lighting procedure must be correct before you even think of landing.

LANDING

25. You will, of course, have practised landing ... until you can do it without any difficulty. On your first operation you will be struck by the similarity of the flare path to the training flare path, and until you are very experienced you take your time and make a job of it. First notice the compass bearing of the line A-B, circle steadily in such a way that you approach light A [the agent's light] from about 300 ft., so that B and C [the up-wind lights] will appear where you expect them and so that you can approach comfortably. Your approach should be fairly steep to avoid any trees or other obstacles and you should not touch down before light A or after a point 50 yards from it. Notice the behaviour of your slats on the way down and don't allow your speed to drop off too much. Use your landing light for the last few seconds by all means, except on the brightest moonlit nights, but switch it off as soon as you are on the ground. Taxi back to light A and stop facing between B and C with your wing tip over light A. While taxi-ing, you will conveniently do your cockpit drill for take-off, so that you are all set when you stop. At this point you may be in rather a flap, but don't forget any letters or messages you may have been given for the agent. Watch the turn about and as soon as you hear your 'OK', off you go.

TAKE-OFF

26. Generally it is worth while to pull out your boost control override and climb away as speedily as you safely can.

THE HOMEWARD JOURNEY

27. Don't forget that navigation on your homeward journey is just as important as on the way out, although you can afford to be slightly less accurate as you approach the coast if you are sure you are approaching it well away from any flak. There used to be a craze for coming out over the Channel Islands, instead of Cabourg. One pilot ascribed this to the magnetic influence of his whisky flask, which he put in his flying boot, but in general it was due to a feeling that you could just point your nose in the direction of home. This, of course, won't do, and, for the sake of your passengers, you should not get shot down on the way back. So navigate all the way there and back.

DOUBLE LYSANDER PICK-UPS

28. The difficulty with a double operation is to arrange for both aircraft to carry out their pick-up within a short time, so that the agents may leave the field before any trouble starts. Normally a limit of 20 minutes is required for the entire operation. To achieve this, pilots must meet at a rendezvous from which they can quickly get to the target, but which is out of earshot of the target, as I said in the relevant paragraph in the first half of the notes. There is always a possibility that one aircraft may not arrive. Pilots are briefed before the operation as to whether they may land if they find they are alone at the rendezvous ...

DOUBLE OPERATION – RT PROCEDURE

29. Don't forget that the Germans wireless intelligence is probably listening with some interest to your remarks. So your RT procedure should be arranged afresh before each operation and no reference should be made to place names or landing and taking-off, or to the quality of the ground, unless this information is coded. For the same reason call signs are usually changed in flight so that, although you may start off at Tangmere as Jackass 34 and 35, at the target you may be Flanagan and Allan. There is no need to talk to each other en route, except where the leader of the operation is deciding to scrub and go home ...

TREBLE OPERATIONS

30. Treble operations are conducted in just the same way as double operations, except that ten minutes should be allowed for each aircraft, so that the total time of the operation may take half an hour. As in double operations, the leader should land first to ensure that the ground is fit and secure and the others should not land until he is airborne and gives them permission.

The first treble operation carried out took nine minutes from beginning to end, but the procedure was unorthodox. The leader³ landed first and took off last, acting as flying control for the other two aircraft and parking off the flare path to the left of light A, where he was turned about simultaneously with the other two. This quicker method has been abandoned because of the additional risk of having two aircraft on the ground at the same time. During double and treble operations, the aircraft waiting to land should fly within sight of the field, but some way from it, to distract the attention of any interfering people on the ground, and these aircraft may profitably organise a diversion some miles from the genuine field.

HUDSON OPERATIONS

31. These are similar to Lysander pick-ups. As each crew will evolve its own technique of cockpit drill and turning about, I will not make any suggestions, except that the crew drill should be carefully thought out and practised to save time and talk during the operation. Landing a Hudson, even on a good night, is difficult on an operational flare path and pilots should not be ashamed of themselves if they muff the approach the first time and have to go round again.

CONCLUSION

32. Pick-up operations have long been outstanding for the good will which exists between pilots and agents, founded during the agents' Lysander training and continued before and after pick-ups. This is most important and all pilots should realise what a tough job the agents take on and try to get to know them and give them confidence in pick-up operations. This is not easy if you don't speak French and the agent doesn't speak English, but don't be shy and do your best to get to know your trainees and passengers and to let them get to know you. Finally, remember that Lysander and Hudson operations are perfectly normal forms of war transport and don't let anyone think that they are a sort of trick-cycling spectacle, for this conception has tended in the past to cut down the number of operations attempted.

Appendix E:

Report on the Activities, Plans and Requirements of the Groups formed in France with a View to the Eventual Liberation of the country

By Jean Moulin; October 1941¹

The three groups which entrusted the author of these lines with the mission of drawing up and handing to the British authorities and General de Gaulle the following message are:

LIBERTÉ, LIBÉRATION NATIONALE AND LIBÉRATION

These three groups constitute the main organizations of resistance to the invader in France.

Although these three movements are certainly known to the British and Free French Intelligence Services, I think it my duty to give a brief outline of their activities.

1. OBJECT

The title assumed by each of these organizations gives a clear enough indication of the object that is being pursued – the liberation of the country. We may as well, add, as a corollary; adherence to the British cause and that of General de Gaulle.

At the beginning anyway, this attitude excluded any interference in domestic policy.

2. HISTORICAL

These three movements were born spontaneously and independently of the initiative of a few French patriots who had a place in the old political groups and parties. They started to assert themselves at different dates, soon after the conclusion of the armistice, however, and as a reaction against this instrument of submission to the enemy. In the beginning, their activities

consisted in spreading by underground channels and in a rather restricted sphere typewritten propaganda pamphlets on every important occasion (speech of Mr. Churchill, of President Roosevelt, speeches of General de Gaulle, outstanding military operations, etc.), or else on every occasion which called for a rebellious attitude on the part of French patriots (annexation by Hitler of Alsace and Lorraine, violation of the clauses of the Armistice, the agreements concluded at Montoire, requisitioning by the Germans, etc.).

Next, with the development of material means and the increased adherence of willing partisans, they were able to publish real roneoed papers at tolerably regular intervals.

Now, for several months, each group has been publishing at a fixed date one or several printed papers in addition to pamphlets and leaflets.

3. PRESENT ACTIVITIES

The activities of the movements LLL extend in three main directions: Propaganda, Direct Action and Military Action.

(a) *Propaganda*

The movement LIBERTÉ publishes every month a newspaper also entitled LIBERTÉ. Very well informed and edited in perfect taste, this organ is run by intellectuals and has a profound influence in university circles. It even has partisans in the official circles at Vichy.

The movement LIBÉRATION NATIONALE, which is led by people in trading and industrial circles in the country and also by the professional classes, nearly all reserve officers, published until quite recently a weekly paper called 'Les Petites Ailes'. This title has been changed to that of 'Verites' for some two months, the only object being to foil the more and more pressing enquiries of the police. It also publishes at intervals a paper – 'Travailleurs' – which addresses itself more particularly to working-class circles.

The tone of 'Les Petites Ailes' and of 'Verites' is voluntarily very moderate, and a very full section is devoted to religious questions. Its milieu, which is very eclectic, varies between royalists of the Bainville type to communists.

LIBÉRATION NATIONALE has also published several important studies, notably on 'Christianity and Hitlerism', and on 'The Economic Results of Collaboration'.

LIBÉRATION, the organ, of the movement LIBÉRATION, is more particularly aimed at working-class circles. A large section is devoted to social problems, and its leaders are at present in contact with a certain person, who has maintained a very great influence on syndicalist circles [Jouhaux].

Each one of the papers of these three movements is printed on the one hand in Unoccupied France, on the other in occupied France, the only difference being in the tone of the articles, which is adapted in each case to the state of public opinion on either side of the demarcation line.

The total circulation of each of these papers (in occupied and unoccupied France), varies between 25,000 and 45,000 but we must multiply these figures by at least five; considering the numerous typewritten or handwritten reproductions which are made. LIBÉRATION NATIONALE, on the other hand, has editions of its papers in Belgium and in Alsace with a column in the latter written in Alsatian.

(b) *Direct Action*

Outside pure propaganda, which for the moment constitutes the main effort, these three movements have other activities.

Recruiting: Combining the call for recruits in their papers with the personal activities of canvassers, the enrolment of partisans has been proceeding despite innumerable difficulties. The organisation, although differing very slightly in each movement, is based on the principle of fellow-members at every scale, and of the automatic and watertight hierarchy of all the leaders, in order to insure that the investigations are in a certain measure neutralised and to enable the movement to pursue its own activities in the event of the arrest of certain of its members. At present, each movement has its own cells and its own cadres in roughly all the departments, whether in occupied or unoccupied France.

Counter-Propaganda: This consists first of all, of boycotting the enemy's means of propaganda and those of his allies; secondly, of the organisation of demonstrations and counter-demonstrations.

Sabotage: The relatively restricted activities of this nature in the beginning enabled certain interesting results to be observed on the occasion of the transport of German material into Lybia; and that of the despatch of French aeronautical equipment to Syria. Today, sabotage has reached a stage where it has become worthy of notice.

Meting-out of Justice: A few operations planned by one of the three movements and directed against the Germans and the 'collaborators' have been carried out.

(c) *Military Activities*

Thousands of items of military information have been given by the members of the three movements to agents of the British Secret Service in occupied France.

A few arms and munitions dumps have been made, especially from the equipment abandoned by French troops.

4. LIAISON WITH ENGLAND

The three movements have each done their best in this direction on their own initiative, but from the beginning, the need to communicate with England has been felt, since England had named itself the champion of resistance, and with the FFL, who were continuing the struggle. As the problems became

more and more complicated with the development and the prolonging of the war, it became necessary to establish contacts and to receive directions and help.

The leaders and a certain number of the followers of the three movements have very frequently tried to create these contacts. The results obtained have been disappointing, a few communications conveyed, out of the Occupied Zone by English planes, or a few information pamphlets received from London by the same means, constituted the only fruits of their labours until recently.

They have several times had the opportunity to complain and set out in detail their wishes to British agents in France, with whom they had worked very successfully. These agents had promised to put their case before high authorities but none of these pleas have had any effect.

One recent attempt could, however, have had useful results if it had been made under different conditions. I mean the mission in France of the Aspirant Z., who was to have entered into contact with movements of resistance in France, as a result of an interallied conference. Was it the youthful age of the agent, or his insufficient knowledge of the problems at stake that made the attempt a failure, resulting only in a series of misunderstandings?

While the anglophile movements in France were thus without any communications with England, Marshal Pétain could however send to London, with all the advantages which the head of a state possesses, a secret emissary, Colonel Groussard. This officer, who at the time had great illusions about the Marshal's will to resist, but whose loyalty concerning his anglophile and anti-German sentiments cannot be suspected, made several visits to London and established very important contacts with the British authorities.²

5. INTER-COMMUNICATION BETWEEN THE THREE MOVEMENTS

Until last July, the three movements LLL had no intercommunication at all, at least none between the higher ranks. This was natural enough considering the infinite number of precautions which these movements must take in order to prevent over-inquisitive investigators from tracing the leaders. As they developed in scope, the three movements realised that these parallel efforts of theirs without any inter-penetration could go on *ad infinitum*, and that it was necessary to bring about some co-ordination.

It was towards the end of July, i.e. before the mission Z, that the first meeting of the leaders of the three movements took place. A very wide survey was made in order to air the various tendencies and aspirations and probable courses of action, etc. This first contact did not bring to life any profound divergence of opinion. Now, quite recently, the 5th of September, four days before my departure, a second reunion took place at Marseilles, which has put the seal on an agreement of principle between the three movements. The practical means of collaboration are at present being studied but from now on it can be said that the following formula will be adopted:

1. Independence in all questions affecting newspapers.
2. Agreements to be made re campaigns, demonstrations, sabotage, etc.
3. One single organization in spheres of military activity.

6. LIAISON WITH OTHER MOVEMENTS

Other movements are also fighting with more or less the same idea at the back of their minds of freeing the country. In the first place, we must mention the communist party, which is by far the most active. What is the attitude of the three movements towards it? We can state quite clearly: collaboration at the bottom of the scale, and goodwill and neutrality between the leaders – strictly within the limits of the struggle against Germany. I do point out, however, that on doctrinal questions the movement LIBERTÉ has definitely ranged itself against Communism. There is also collaboration among the lower rungs of the ladder with the associations of Freemasons, whose activity is especially great in the sphere of ‘oral’ propaganda. There is also collaboration with certain old groups, such as La Ligue des Droits de l’Homme.

Contacts exist with the movement of General Cochet, who is at present imprisoned and whose former collaborators continue his work; also, with certain members of the groupe d’Astier de la Vigerie.

We should also mention the ex-association of the Cagouleurs, which has played such an important part in the rise of Pétain. Here, there were from the beginning two tendencies, or rather two parties that were definitely opposed: one, pro-nazi, with Deloncle, the other which hoped to play the game of the British through the intermediary of Pétain and which reached its apogee when Colonel Groussard, then leader of the Ephémères GP, carried out the arrest of Laval. We need not talk of the first tendency. We must, however, bear in mind a very definite evolution in the opinions of the followers of the second movement, since the misfortune which overtook Groussard.

The latter was arrested after one of his visits to England, by order of Darlan, at the very time when he was carrying a secret operation order from Pétain. Since his imprisonment at Vlas les Bains, Groussard has had ample time to reconsider his opinions and I have it on good authority that he has now abandoned the hopes which he had of the Marshal. I personally was entrusted in France with the safe-keeping of a most damaging dossier which he drew up on Pétain and which I have been asked to publish in case anything happens to Groussard.

Considering the importance of Groussard, who was at the head of the Ecole de St Cyr, cradle of the French officer-class, his imprisonment and his no doubt sincere change of opinion cannot have failed to have had certain repercussions. Contacts are at present made between the three movements and the political allies of the Colonel.

That, in brief, is the sum of the activities of the three movements.

THE SITUATION IN FRANCE

More and more now, the population in France is beginning to become conscious of its strength of resistance and to yearn to shake off the yoke.

The communist party has certainly resumed a great activity ever since the Russo-German war, and it wants at all costs to keep the greatest number possible of German divisions in France in order to alleviate the pressure on the Russian front. Recent demonstrations, however, have not all by any means been sponsored by communists. If one was at all in doubt, one would only have to refer to the unforgettable 11th of May in Paris, by which time the communists had not yet started to make themselves active.

These demonstrations are primarily a reaction of popular revolt and indignation.

Passions have been roused. De Monzie, who although a pro-fascist and an admirer of Pétain, nevertheless thought it his duty three months ago to finish his book of memoirs *Ci-Devant* with the following references:

Ezechel – 7-23 Id est:
 ‘Prépare des chaînes
 ‘Le pays est rempli de meurtres
 ‘La ville est pleine de violences’

The metaphor is a very appropriate one.

Besides, several followers of collaboration feel themselves that Pétain and Darlan have gone too far in their policy of submission. Laval, before the attempt on his life, was wont to joke ‘Il fallait donner un oeuf pour garder la poule. Ils ont donné la poule et ils n’ont même pas sù garder l’oeuf.’

The arrests without trial of several officers and political personalities, well known for their patriotism, made the most unpleasant impression on the public, once they became known.

Does that mean to say that the government has lost some of its adherents? No. These losses have been made up and more than made up. Several conservative bourgeois, who were being anglophile in a dilettante manner, have recently thrown themselves into the arms of Pétain out of fear of the communist bogey which is cunningly flaunted by Berlin and by Vichy – this is true of both occupied and unoccupied France. They have been greatly encouraged by the attitude of the catholic clergy, which is more and more pro-government.

Nevertheless, the uneasiness is becoming more and more profound, and if the gaullists have lost a little in numbers, they have won an immense force in militant and fighting strength and one can say that they have now exchanged passive resistance for active resistance.

The movements which had singled out for themselves the goal of the liberation of the country have thought it their duty to canalise the violences

of the public and to discipline them by forging the technical instrument of collaboration with the Allies, and notably the military instrument. It is for this reason that they have made a sudden number of plans in this respect.

PROPAGANDA

A plan for the development of propaganda has been studied by each movement, and it entails:

1. Increase of publication of the existing organs and improvement in their presentation. Creation of new and numerous newspapers in order to confuse investigations by the police. Creation of illustrated satirical papers. Greater rapidity in circulation, etc.
2. Creation of secret radio transmitting stations in mobile lorries.
3. Various propaganda campaigns – scrawling on the walls, roads, monuments; spreading of leaflets released from balloons, etc.
4. The creation of propaganda teams specialised in verbal propaganda.

SABOTAGE

The extension of sabotage against the enemy war machine and throughout French factories working for the enemy. Centralisation of technical teams, etc.

METING-OUT OF JUSTICE

The creation of brigades of avengers, who are to work on preconceived plans. Their function will be to publish the names of ‘mauvais français’ and to punish them. One of the three movements is planning to brand notorious traitors with the swastika.

MILITARY ACTIVITY

This is the main problem. The movements LLL are at present studying the possibilities of forming cadres of training, and of arming French patriots with a view to eventual action in co-operation with the Allies on French soil. Are they right? They believe it and defend themselves with the following arguments:

1. Firstly, a moral argument. They believe that, if France can count on the infinitely powerful and valuable help of Great Britain, it is incumbent upon Frenchmen to try above all to save themselves, or at least to add their contribution to their final salvation.
2. Tens and even hundreds of thousands of Frenchmen, mainly in occupied France, yearn to join the FFL in order to continue the fight at England’s side. Those who were lucky enough to do so after the Armistice represent only a small minority. The others have had to abandon the idea in face of the

impossibility of finding the necessary help. This ardent mass of Frenchmen, which has remained under the yoke, is champing the bit and is only awaiting the opportunity to shake off this yoke. It would be mad and criminal not to make use of these soldiers, who are prepared to make the greatest sacrifices, in the event of any widescale operations by the Allies on the Continent; scattered and anarchical as they are today, these troops can tomorrow constitute an organized army of 'parachutists' *on the spot*, knowing the country, having singled out their opponents and decided on their objectives.

3. If no organization imposes upon them some sort of discipline, some orders, some plan of action, if no organization provides them with arms, two things will happen:

On the one hand, we shall witness isolated activities, born to certain failure, which will definitely go against the common goal because they will take place at the wrong moment, in a disorganized and inefficacious manner and thereby discourage the rest of the population.

On the other hand, we shall be driving into the arms of the communists thousands of Frenchmen who are burning with the desire to serve – and this process will be helped all the more since the Germans themselves are the chief recruiting agents of the communists, citing as 'communist' all demonstrations of resistance on the part of the French people.

4. Admitting that neither the suggestion of a landing in France or in any other point in western Europe, nor that of a simultaneous uprising of all the occupied nations might materialise, the movements LLL are convinced that at the time of a British victory France will be in such a state that the brigades formed by French patriots will be of the utmost necessity in keeping order and in smoothing over the transition from one regime to the other. (Here we may as well add in parentheses, that evil tongues are spreading the rumour among de Gaulle circles in France that the British leaders would not be displeased to have the government of Marshal Pétain remain, even after the crushing of Germany, in order that peace should be made in the best possible conditions, with a discredited partner.)

The movements LLL do not insult their British friends by believing these rumours. But they do earnestly hope that they can reassure in no uncertain manner many of their followers who are at present fighting at their own peril in order to free their country, as much from the enemy's henchmen as from the enemy himself.

The three movements have, from the point of view of military activities, a certain number of plans which entail the following: Increasing the number of enrolments, formation of cadres, instruction in fighting, reconnaissance of strategic points, diffusion of orders, landing of arms, whether in occupied or unoccupied France, transit of arms from one zone to the other, dumping of arms, etc.

NECESSITY FOR IMMEDIATE AID

Without aid in all spheres of activity, the influence of the movements LLL will be in vain. They have reached today the highest peak possible with the means at their disposal and it is not at all certain that they will be able to maintain themselves at their present high level, even in the matter of propaganda, unless they receive some prompt and substantial help.

The movement which has accumulated the most funds during the last year has not got at its disposal more than 400,000 francs. Two months ago, 'Les Petites Ailes' almost ceased to function owing to lack of funds. At every moment, active partisans of these movements are held up for lack of material means. Three days before my departure, the leader of the propaganda section of one of the movements was arrested for resorting to the only elementary means left open to him of obtaining money for the movement. It must not be forgotten that never can use be made of the postal, telegraph or telephone systems: and that all transport and communication are effected by emissaries despatched on bicycles or by train.

The movements should be enabled to conceal their activities as far as possible beneath a commercial or industrial cloak, which would have the advantage of removing suspicion and of providing the necessary material resources – lorries, cars, engines, personnel, etc. For all this, money is needed. The monthly sums asked for by the three movements in order immediately to widen their scope are hardly the equivalent, at the present rate of exchange of our valueless franc, of one-fifth of the cost of a bomber, and hardly more than the price of a single leaflet raid by a few planes.

Summing up, the movements are asking for:

1. *Moral backing-up.*
2. *Inter-communications* – frequent, rapid and reliable. Contacts must be established with General de Gaulle, which will enable a concerted plan of action to be agreed upon and carried into execution.
3. *Funds* – to begin with, a sum of 3 millions a month for the three movements – this sum ought to be doubled at the end of the year.
4. *Arms* – 1st stage: very light equipment – revolvers and submachine guns. 2nd stage: light equipment – rifles, automatic rifles, and machine guns.

As a mere messenger, briefed by the movements LLL to transmit an SOS to London, may I be permitted to point to the magnificent spirit of sacrifice of their leaders and of their followers and to their unshakeable will to free their nation. Some have already paid with their lives for devotion to the cause. Countless others crowd French and German prisons. Those carrying on the fight must not be left helpless.

It is in the immediate interests of Great Britain and her Allies. It must also be one of the *raison d'être* of the FFL. It is the hope of a whole people enslaved.

N.B. It must be made clear, and I insist on these points:

1. That the mere fact of giving money and arms to the movement is not designed to increase for the present the number and importance of certain acts of violence. The object to be achieved is first and foremost to *intensify propaganda* and to organize eventual collective action for the future.
2. That there can be no question of aiding a revolutionary movement against the government of Vichy (at least not without previous agreement with London). The only question at stake is the fight against the Germans, and the men of Vichy are to be considered as opponents only insofar (and in such measure) as they help the enemy.
3. That the three movements are agreed that it is up to the FFL to make the required effort.

Appendix F:

Typical F Section Operation Orders

(i) *For Captain Robert Benoist, organiser of CLERGYMAN*

29.2.44

Operation Instruction No. F.80

Operation: CLERGYMAN
Field Name: LIONEL
Name on papers: Daniel Perdrige

1. INFORMATION

We have discussed with you carefully the possibilities of your returning to France to carry out a mission which you were originally given when you left for that country in October 1943.

You have made it quite clear to us that in your view nothing prevents your returning to the same area to carry out the same tasks.

These were in particular the bringing down of high pylons over the river Loire at Ile Heron, and the preparation of railway blocks on the lines converging on NANTES. You have told us that you have reconnoitred the pylons and only await material in order to carry out the job, and also that railway teams are being organised in the NANTES district, and will be capable of action as soon as necessary materials are received.

2. INTENTION

(a) You will return to the Field by Lysander accompanied by your W/T operator during the March moon.

(b) You have been given particulars of a ground where you can receive the materials necessary to carry out your mission, and you will organize a reception on this ground as soon as possible.

(c) You will thereupon organise;

1. An immediate attack on the high pylons crossing the river Loire at Ile Heron.
 2. The formation, training, and supplying of teams to cut, on receipt of orders on D-day, the railway lines converging on NANTES. It is at this stage important for us to know exactly where these cuts will take place and we require therefore for you to report back to us where action may be expected, and for this purpose if your cut is proposed 15 km. from the line NANTES-CLISSON you will report this to us as: 'NANTES CLISSON QUINZE ROTTEN'. 'Rotten' being the code word indicating that the target is prepared and ready for action, and 15 km. being the distance from NANTES on the line NANTES-CLISSON where the cut will take place.
 3. The formation, training, and supplying of teams to cut, the civil telephone lines converging on NANTES. We do not advocate attacks on telephone exchanges since these are heavily guarded and require a larger personnel, but rather a series of cuts on the lines themselves which will have the same effect. A map of these lines has been shown to you and you have been given a micro photograph of it.
- (d) We emphasize that apart from the destruction of pylons already mentioned the main importance of your mission is to ensure that we have in the NANTES area an organization capable of interference on an effective scale with German communications on D-day.

We had not therefore given you any further targets for immediate action in order that you may concentrate on the formation and the security of the groups necessary for carrying out your tasks for D-day.

(e) We consider that the organization of these objectives in the NANTES region is a full-time task and we do not therefore consider that you will have time to carry out any activities in other areas.

If, however, you find that your organization in the NANTES area has gone so well that you are able to leave it in the hands of your lieutenant, then we are perfectly prepared to send to you directives for a further mission in the PARIS area. This cannot however be considered until the NANTES organization is complete.

(f) We have explained to you our system of BBC messages for transmission of orders for target activity on D-day.

The following are the messages for your circuit:

1. For railway targets:
 - A. C'ETAIT LE SERGEANT QUI FUMAIT SA PIPE EN PLEINE CAMPAGNE
 - B. IL AVAIT MAL AU COEUR MAIS IL CONTINUAIT TOUT DE MEME
2. For telephone targets:
 - A. LA CORSE RESSEMBLE A UNE POIRE
 - B. L'ITALIE EST UNE BOTTE

The pylons of course require no BBC message since they are for action at the earliest possible opportunity.

3. ADMINISTRATION

It is never our policy to get together large groups of men since in our opinion the only effective basis for effective action is the small self-contained group. This applies in your particular case since all targets given to you can be dealt with by small groups.

Finance

You will take with you to the Field the sum of 500,000 francs and you will give us an idea as early as possible of what your financial needs are likely to be.

Note that there have been changes in our system of sterling-francs transactions. The rate of exchange is now 200 francs to the £, but it is a definite rule that no transaction whatsoever may be entered into without prior approval from us. Moreover it is also to be noted that such transactions are only for use in emergencies.

29.2.44

Operation: CLERGYMAN

Operation Instruction No. F.80 – Part II

1. METHOD

- (a) You will proceed to France by bomber or Lysander to a point
 - 10 km. S. Vatan
 - 2.5 km. W. Villeneuve
- (b) You will be received by a reception committee, who will give you any assistance you may require during the first few hours after your arrival and will see you on to a train to get to your final destination. After leaving the reception committee you will have no further contact with them whatever.
- (c) You have been given a cover story and papers in the name of Daniel PERDRIDGE, which you will use for your normal life in the field. If, for any reason you should take a new identity you must inform us immediately and give us details. To cover your personality as an agent you will continue to use the name LIONEL.

2. INTERCOMMUNICATIONS

(a) *W/T communication*

You will be accompanied to the field by AMBROISE, who is to act as your W/T operator. She will be under your command, but it must be understood that she is the ultimate judge in all questions regarding the technicalities of W/T and W/T security. She will encode the messages herself. They should be as short and clear as possible, since it is of the utmost importance that her time on the air should be reduced to the minimum.

(b) *Postboxes*

You will send us as soon as possible the address of a postbox (or postboxes) through which we can contact you in the event of radio communications breaking down. We emphasize that if a postbox is cancelled, the address of another should be sent to us immediately to replace it.

(c) *Codes*

In view of the mutilations to which messages by W/T are subject, we consider it inadvisable for you to use your own code for messages to be transmitted by radio. You will, however, use your personal code for communicating with us by other means than radio. In the case of reports we point out that it is not intended they should be entirely in code, but that your code should be used for any names, e.g. of people and/or places, which may be of a compromising nature.

3. CONCLUSION

You have been given our general briefing and have [received] our general instructions in regard to security, our grid system of map reference, lighting system for landing grounds, etc. You have read the foregoing briefing and have had an opportunity of raising any questions on matters that have not been clear to you.

(ii) *For Lieutenant Marcel Clech, wireless operator to INVENTOR*

11.5.43

Operation: GROOM

Christian name in the field: BASTIEN

Name on papers: Yves LE BRAS.

MISSION

You are going into the field to work as W/T operator for two organizers, PAUL and ELIE. You will be under the command of Elie, whom you have met here and who will be travelling with you. Besides his job as organizer, he is to act as our liaison officer with Paul, who has an organization already established in the district bounded by Troyes, Nancy and Besançon.

APPROACH

You will go into the field by Lysander with Elie and his courier, Simone, to a reception committee at a point

14 km. E.S.E. of Tours

11 km. W.S.W. of Amboise.

As soon as possible after your arrival you will make your way to Paris to a safe address which you already know and stay there until you receive further instructions from Elie. This address is

Monsieur Cornie,

22 bis rue de Chartres,
Neuilly s/Seine.

If, by any mischance, you should lose contact with Elie the following address is given you to enable you to get in touch with Paul

Mme. Buisson,
203 ave. du Roule,
Neuilly.

Password: Amour, amour.

There you should ask to be put in touch with Monsieur Frager or leave a letter for him. Frager is the name by which Paul is known at this address. It is stressed that you should contact him **ONLY** if you lose contact with Elie.

METHOD

1. You have been given a cover story and papers in the name of Yves Le Bras, which you will use for your normal life in the field. To cover your personality as an agent you will use the name BASTIEN.
2. You will receive and send messages for Elie's circuit. You will send only those messages which are passed to you by Elie or which are approved by him. Although you are under his command and will take your instructions from him, you are the ultimate judge as regards the technicalities of W/T and W/T security. We should like to point out here that you must be extremely careful with the filing of your messages.

The circuit password of Elie and Paul is

'Je viens de la part de Celestin.'
'Ah, oui, le marchand de vin.'

FINANCE

You will be taking with you Frs. 151,335 for your own use. You will endeavour to keep an account of what you spend and will apply to Elie when you require further funds.

COMMUNICATIONS

1. You will sever your contact with the people who receive you as soon as possible and, after that, will refrain from contacting members of any circuit apart from your own.
2. As regards your wireless communication with us, we would stress that you should only be on the air when necessary and that your transmissions should be as short as possible. You will encode the messages yourself.
3. You will send us as soon as possible the address of a postbox through which we can contact you personally should the wireless communication break down.
4. You will also send us the address of a 'cachette'. Should you be in difficulties you will go to your cachette and advise us of the circumstances by coded letter or card to this address:

Snr. Leonel Martins,
20 Travessa Enviado Inglaterra,
Lisbonne.

We will then contact you at the cachette with a view to getting you out.

5. For communicating with us by other means than W/T, you will use your personal code.

CONCLUSION

You have had our general training, our W/T training and a W/T refresher course during your visit to this country. You have had our general briefing and with regard to the briefing herewith you have had an opportunity of raising any questions on matters that have not been clear. You have also had a trial viva voce of the methods outlined. You understand that you are to receive your instructions from Elie and that you are to carry them out to the best of your ability. If, through any unforeseen circumstances, Elie should disappear, you will advise us and receive further instructions direct from us.

Appendix G:

Industrial Sabotage

It has been said that nothing is so tedious and so unilluminating as a bare list of acts of sabotage; though Selborne sent a long one to the chiefs of staff in January 1944, in support of a declaration of faith in SOE.¹ The list below may nevertheless retain a certain interest; it is compiled from notes made by Brooks when he was sent round France in the winter of 1944–45 to investigate all the claims of actual industrial sabotage inflicted by F section, and some of the outstanding RF operations of the same kind.

A total of about 3,000 lbs (1,360 kg) of explosive – plastic in almost every case – was required to inflict this substantial quantity of damage.

<i>Place</i>	<i>Firm</i>	<i>Product</i>	<i>Date</i>	<i>Results</i>	<i>Notes</i>
Decazeville	—	Coal	24 August 1943 1 January 1944 3 January 1944 25 January 1944 28 February 1944 19 March 1944 30 May 1944 7 June 1944 11 June 1944 13 June 1944	10 days' stop. 1 day's stop. 2 days' reduced production. 2 days' stop. 4 days' stop. Output cut to 20 per cent for eight weeks. 3 months' stop of cableway. Electricity cut for two weeks. 2 weeks' stop. 6 weeks stop on surface workings.	Lift gear broken. Winch damaged. Electricity cut off. Pit exit shaft blocked. Transformer destroyed. Extraction gear damaged. — Three of eight charges did not explode. Skipp destroyed. Winch gear destroyed. Management thereafter agreed to suspend production till liberated.
Sochaux-Montbéliard	Peugeot	Tanks	5 November 1943 10 February 1944	3 months' stop. Several months stop.	First 'blackmail' operation. Replacement machine tools destroyed on arrival from Germany.
Sochaux-Montbéliard	Peugeot	Aircraft parts	About 15 January 1944 10 February 1944 15 March 1944	3 weeks' stop. 5 weeks' stop. Output cut to 40 per cent.	— Replacement machine tools destroyed on arrival from Germany. Replacement machine tools destroyed on arrival from Germany.
Eguzon	—	Electricity	10 October 1942	Short stop.	—

<i>Place</i>	<i>Firm</i>	<i>Product</i>	<i>Date</i>	<i>Results</i>	<i>Notes</i>
Chaungy-Orleans Figéac	— Ratier	Electricity Variable pitch propellers	25 April 1943 January 1944	Trivial stop. Stop till liberation.	— —
Courbevoite, Seine	Bronzavia	Aircraft parts	4 April 1944	3 weeks' stop; production never again over 90 per cent.	3 Germans killed.
Boulogne-sur-Seine	Air Liquide	Compressed air, etc.	11 November 1943 19 March 1944	Slight delay. 2 weeks' stop; permanent stop for liquid oxygen; 25 per cent cut for the rest.	Charges faultily laid. Production engineer's advice not taken.
Asnières, Seine	Timken	Ball bearings	6 April 1944	2 weeks' stop; production never again over 28 per cent.	Workmen encouraged to go slow.
Aubervilliers, Seine	Malicet & Blin	Ball bearings	19 May 1944	Production reduced to 20 per cent for some weeks.	—
Boulogne-sur-Seine	Renault	Tanks	28 April 1944	Production reduced to 20 per cent for three months; eight tanks damaged; armoured car stolen.	—
Ivry-sur-Seine	C.A.M.	Ball bearings	17 May 1944	Production reduced to 80 per cent.	Poor choice of targets
Levallois-Perret, Seine	Arsénal national	Light artillery	19 February 1944	4 weeks' stop; never back in full production.	—
Sevran, S-et-O	Westinghouse	Brakes	2 July 1944	Production reduced to 20 per cent for six weeks.	Successful counter-scorch

<i>Place</i>	<i>Firm</i>	<i>Product</i>	<i>Date</i>	<i>Results</i>	<i>Notes</i>
Beaumont-sur-Oise, S-et-O	Poliet & Chausson	Cement	9 May 1944	6 weeks' stop.	Factory already out of action—no coal.
Montataire, Creil, Oise	Brissoneaux & Lotz	Rolling stock	14 July 1942	Production reduced to 70 per cent for 12 weeks.	Three out of four compressors damaged.
			18 January 1944	1 week's stop.	Transformers damaged.
			1 May 1944	Production reduced to 70 per cent for eight weeks.	Two compressors damaged.
Choisy-au-bac	Engelbert	Tyres	23 July 1944	8 weeks' stop.	Large fire; and power house damaged.
Dieppedalle, Rouen	—	Electricity	31 October 1943	Over six months' stop.	—
Mantes-Gassicourt, S-et-O	Cellophane	Cellophane	December 1942	Complete stock of fibrane burnt.	—
			May 1943	1m kilos wood pulp burnt.	—
			1 October 1943	1 week's stop.	—
Déville-lès-Rouen, Seine-inf	Sté fçse. des Metaux	Machine tools	10 October 1943	2 weeks stop; production reduced by half for over six months.	—
Mantes, S-et-O	C.I.M.T.	Rolling stock	25 September 1943	Compressor destroyed; 2 days stop.	Second 2lb charge on second compressor did not explode.
			2 November 1943	10 days stop.	—
Fives-Lille, Nord	Ateliers de Fives-Lille	Locomotives	27 June 1943	Production reduced to 20 per cent for four days.	—
			3 October 1943	2 days stop.	Wrong cranes attacked.

<i>Place</i>	<i>Firm</i>	<i>Product</i>	<i>Date</i>	<i>Results</i>	<i>Notes</i>
Roubaix, Nord	Air Liquide	Compressed air	15 June 1944	4 weeks' stop	—
Liévin, Pas de Calais	Sté fçse.des Essences	Petrol	17 July 1944	13 weeks' stop.	—
			4 July 1944	Stop till after liberation.	Attack within two days of shift of product to Germans.
Clermont-Ferrand	Chartoir	Aero engine parts	31 December 1943	1 week's stop.	—
			18 July 1944	Stop.	Fire
	Jean Crepelle	Compressed air	7 November 1943	All stocks burnt.	Attackers unknown; their stores probably British
			20 August 1944	Most of factory burnt out.	—
	Douai-Corbehem, Nord	Michelin	Tyres	3 June 1943	Over 300 tons of tyres burnt.
26 November 1943				Some vehicles taken; a few tyres burnt.	—
5 December 1943				Nil.	Charges did not explode; had they done so, stop would have been total.
Blois	Bronzavia	Wireless equipment	21 May 1944	2 weeks' stop; then slow running till liberation.	Destroyed transformer; replaced from chocolate factory.
Montluçon	S.A.G.E.M.	Anti-tank guns and sound detectors	21 January 1944	Production reduced.	—
			29 February 1944	Six detectors destroyed.	Leader trained himself from parachuted booklet.
Montluçon	Dunlop	Tyres	29 April 1944	2 weeks' stop	Production had just restarted after air raid in September 1943.
			28 June 1944	Water pump destroyed; no delay.	—

<i>Place</i>	<i>Firm</i>	<i>Product</i>	<i>Date</i>	<i>Results</i>	<i>Notes</i>
Montluçon	Dunlop	Tyres	25 July 1944	Stop in lorry tyre shop till liberation.	Transformer destroyed.
Prémery, Nièvre	Lambiotte	Acetone etc.	7 October 1943 29 April 1944	Small fire. 6 weeks' stop; production reduced till liberation.	— —
Fourchambault, Nièvre	S.N.C.A.C.	Aircraft	3 May 1944 20 September 1943	100,000 litres acetone, etc. burnt. Output cut to 20 per cent for eight weeks.	— —
Teillet-Argenty, near Montluçon	C.E.L.C.	Electricity	20 October 1943 16 December 1943	Slight. 1 week's stop; 22 tons oil lost; then output cut to 20 per cent for eight weeks and to 40 per cent till after liberation.	Most charges discovered and removed. —
Tulle, Corrèze	Arsénal national	Guns?	7 January 1944	Almost total stop.	Auxiliary power supply destroyed; main grid constantly interrupted thereafter.
Tulle-Virevialle	Arsénal national	Electricity	14 December 1943	8 tons oil lost; one week's stop.	—
Limoges-St. Marc	—	Hydro-electricity Hydro-electricity	23 February 1944 24 June 1944	6 weeks' stop. 6 weeks' stop; then output cut by two-thirds for two weeks and by one-third for two weeks more.	— —
Bussy, Htc. Vienne	—	Hydro-electricity	July 1943	3 weeks' stop.	—

<i>Place</i>	<i>Firm</i>	<i>Product</i>	<i>Date</i>	<i>Results</i>	<i>Notes</i>
Bussy, Hte. Vienne	—	Hydro-electricity	22 May 1944	12 weeks' stop; output then cut by two-thirds.	Unnecessarily violent attack.
Limoges-Des-Cassaux	—	Electricity	28 May 1943	Output cut by two-thirds for 15 months.	Go-slow on repairs.
Eguzon, Indre	—	Electricity	31 December 1943	80 tons oil lost; 12 weeks' stop.	One man set two small charges.
Brive-la-Gaillarde, Corrèze	Phillips	Wireless valves	21 October 1943	4 weeks' reduced output.	Vacuum pump and experimental equipment destroyed.
Ancizes, Puy-de-Dôme	Aubert & Duval	Steel	26 March 1944	Output almost stopped till liberation.	Blast damage severe.
			16 May 1943	12 weeks' stop.	Damage attributed to defective coal.
			13 November 1943	4 weeks' reduced output.	—
			8 February 1944	Water reservoir badly damaged.	—
			19 April 1944	2 days' stop.	—
			2 May 1944	Stop till after liberation.	Co-operative management.
Ussel, Corrèze	Montupet	Aluminium cylinder heads	20 June 1942	2 days' stop.	Workers also engaging in passive sabotage.
			11 December 1942	8 months' stop.	—
			25 March 1944	4 weeks' stop, then output cut by 85 per cent till liberation.	—

<i>Place</i>	<i>Firm</i>	<i>Product</i>	<i>Date</i>	<i>Results</i>	<i>Notes</i>
Bar, Corrèze	—	Hydro-electricity	26 May 1944	4 months' stop	40 German soldiers on guard, since Tulle arsenal was supplied from here. Conduit into Tulle attacked and destroyed.
Carmaux, Tarn	Cie Gle Industrielle	Textiles	3 April 1944	1 day's stop; slight fall in output.	Transformer spares available.
Tarascon-sur-Ariège	Forges d'Alais & Camargue	Aluminium	6 May 1944	Slight delay	Though factory power plant was destroyed, grid provided future power supply.
Bordères-Louron, Htes. Pyr	Sté. des Produits Azotés Bordères	Chemicals	8 February 1944	6 weeks' stop.	—
Gripp, Htes. Pyr	Sté. Hydro-electr. de la moyenne Garonne	Hydro-electricity	30 April 1944	6 weeks' stop.	—
Montbarrier, Tarn & Garonne	—	Copper	20 March 1944	4 weeks' stop; output cut by 50 per cent till liberation.	—
Stc. Lary, H-Pyr	—	Electricity	14 April 1944	Output cut by 50 per cent till liberation.	—
Sarrancolin, H-Pyr	Alais, Froges & Camargue	Aluminium	13 March 1944	2½ weeks' stop on local power supply.	Main output not affected; corundum by-product stopped for period shown.
Lavelanet, Ariège	—	Electricity	9 April 1944	2 months' stop on same.	Main output not affected; corundum by-product stopped for period shown.
Laruns, B-Pyr	—	Electricity	27 March 1944	24 tons oil burnt; 7 transformers destroyed; output greatly reduced.	—
Lannemazan	S.E.E.A.E. d'Ugine	Aluminium	3 August 1944	7 weeks' stop.	—
			30 May 1944	5 months' stop	—

<i>Place</i>	<i>Firm</i>	<i>Product</i>	<i>Date</i>	<i>Results</i>	<i>Notes</i>
Mauzac, Dordogne	E.E.S.O.	Electricity	12 February 1944	4 months' stop.	6 lb explosive failed; engineer damaged equipment involved with hammer and chisel.
Tarbes, H-Pyr	Hispano-Suiza	Aero engines	29 March 1944	2 transformers destroyed.	Grid maintained output of seven engines a day, practically unaffected.
			13 April 1944	5 months' stop.	Cylinder head casting moulds destroyed.
Tarbes, H-Pyr	Arsenal national	Guns	30 August 1943	Main switchboard destroyed; one day's stop.	—
			25 May 1944	4 months' stop on all 150mm and 205 mm guns.	—
Fontpedrouse, Pye-Or	SNCF	Hydro-electricity	31 March 1944	3 weeks' stop.	—
St. Georges, T-et-G	SNCF	Hydro-electricity	23 September 1943	1 day's stop; output cut to 50 per cent for eight weeks.	—
Gesse, Aude	SNCF	Hydro-electricity	23 September 1943	10 days' stop; then output cut to 15 percent for four weeks.	—
Escouloubres, Aude	SNCF	Hydro-electricity	23 September 1943	4 weeks' stop.	—
Usson, Ariège	—	Hydro-electricity	23 July 1944	8 weeks' stop.	—
Carcanières Ariège	—	Hydro-electricity	23 July 1944	1 day's stop.	—
Pau	Sté. fçse. d'Optique et de Mécanique	Optical instruments	12 April 1944	8 weeks' stop; then output cut to 50 per cent.	Machine tools attacked.

<i>Place</i>	<i>Firm</i>	<i>Product</i>	<i>Date</i>	<i>Results</i>	<i>Notes</i>
Pau	Sté. fçse. d'Optique et de Mécanique	Optical instruments	5 May 1944	Took two weeks to repair.	Power plant attacked — reinsurance.
Lannemezan	Sté. des Produits Azotes	Various metals and chemicals	20 July 1943	A little oil lost.	Transformer attacked but rapidly repaired.
			8 January 1944	One engineer injured.	Engineer removed charges before they exploded.
			16 February 1944	New compressor destroyed.	It had arrived that afternoon.
			26 February 1944	2 days' stop on manganese production.	—
			26 May 1944	Compressor destroyed; no more hydrogen produced until after liberation.	—
Bourges	S.C.A.C.	Transport aircraft	7 August 1944	19 aircraft destroyed; stop on further production	—
Bagnères de Bigorre	Lorraine Dietrich	Self-propelled gun carriers	13 May 1944	6 months' stop; 48 machine tools, etc., damaged or destroyed.	—
Lyons	Bronzavia	Aircraft engine parts	27 January 1944	15 machine tools and 42 engines attacked; all but three engines destroyed or badly damaged; 4 weeks' stop, output then cut to 40 percent till September.	Police informed half-hourly by telephone that all was well.
Lyon-Villeurbanne	Le Roulement	Ball bearings	11 November 1943	2 weeks' stop.	Transformer damaged.

<i>Place</i>	<i>Firm</i>	<i>Product</i>	<i>Date</i>	<i>Results</i>	<i>Notes</i>
Lyon-Villeurbanne	Le Roulement	Ball bearings	23 April 1944	2 weeks' stop; output then cut to 30 per cent.	Seven machine tools attacked; police removed two charges.
Gardanne, B-d-R	Forges d'Alais and Camargue	Aluminium	13 June 1942 30 April 1943	Output cut for several months. Output cut for several months.	One-man job. One-man job.
Grenoble	Brun	Alcohol	5 March 1944	Output cut to 40 per cent for over a year.	15 men at work.
Grenoble	F.I.T.	Rubber	7 July 1943	Plant destroyed.	One attacker killed by a guard.
Salindres, Gard	Forges d'Alais and Camargue	Aluminium?	13 July 1944	3,000 tyres burnt; four months' stop.	—
L'Estaque B-d-R	Kuhlmann	Chemicals	8 June 1944	Slight cut in output.	Three out of four boiler feed pumps destroyed.
St. Marcel, B-d-R	Coder	Rolling stock	16 April 1944	300 tons oil burnt; output unaffected.	—
			20 June 1944	Three transformers destroyed; output unaffected.	—
			14 July 1944	Three compressors destroyed; one week's stop; output then cut to 90 per cent.	Two spare compressors over-looked.
Béziers, Hérault	Fouga	Locomotives	21 April 1944	One compressor destroyed; output cut to 90 per cent.	Charge on second compressor failed.
			30 April 1944	Two mobile transformers out of action for four months.	—
Notre-dame de Briancçon	S.E.E.A.E.	Hydro-electricity	8 May 1943	Conduit cut; some fall in output.	—

<i>Place</i>	<i>Firm</i>	<i>Product</i>	<i>Date</i>	<i>Results</i>	<i>Notes</i>
L'Eau Rousse, Htes. Alpes	S.E.E.A.E.	Hydro-electricity	10 July 1943 12 August 1943 29 November 1943 ? 23 January 1944 25 January 1944	1 month's stop. Conduit cut; some fall in output. 2 months' stop. Spare transformer destroyed. 4 months' stop; output then much reduced. 2 weeks' stop.	— — Rebuilt by spring.
Ugine	S.E.E.A.E.	Hydro-electricity	13 December 1943 28 December 1943 onward 25 March 1944	Conduit under constant attack. Both auxiliary pump motors destroyed; one week's stop.	Both alternators heavily damaged. — Firm fell back on two auxiliary pumps.
Notre-dame de Briançon	Stc. des Electrodes de la Savoie	Electrodes	5 May 1944 6 May 1944 24 October 1943	Mechanical coal supply heavily damaged; large cut in output. Cables cut; two days' stop. 2½ months' stop.	— — —
Annecy, Hte. Savoie	S.R.O.	Ball bearings	25 January 1944 13 November 1943 25 November 1943	3 months' stop. 3 days' stop; two weeks' partial output. 15 machine tools attacked; output slowly raised to 40 per cent.	— — Two charges failed.

<i>Place</i>	<i>Firm</i>	<i>Product</i>	<i>Date</i>	<i>Results</i>	<i>Notes</i>
St. Etienne	Nadella	Ball bearings	30 April 1944	Eight machines destroyed.	70 more had uninitiated charges.
Lyon-Vénissieux	S.I.G.M.A.	Aircraft engine parts	27 November 1943	1 week's stop; output partial only for three weeks' more.	Four transformers and a compressor damaged; choice of targets bad. Plant engineer said later 'far more damage could have been done by hitting each crankshaft in stock with a hammer and also by attacking the four rectifiers which were impossible to replace'.
Lyon-St. Fonds	Paris-Rhône	Electrical equipment	20 January 1944	1 week's stop; output thereafter 60-70 per cent.	—
Lyon-Vénissieux	S.O.M.U.A.	Rolling stock, armour, etc	26 February 1944	1 week's stop; output up to 70 per cent in a week more, except in heavy machining which was up to 30 per cent after two months.	Plant was armouring a German train. Over 30 unexploded charges.
Belfort	Alsthom	Shell cases	1 October 1943	Two pumps destroyed; stop in one shop for three months.	Go slow over repairs.
Belfort	Coechlin	Lorries	18 December 1943	Large fire; output reduced.	—
Launéville	Lorraine	Half-track fighting vehicles	6 July 1944	Five half-tracks destroyed.	Wehrmacht had taken delivery that day.
Le Creusot?	Cie Bourguignonne de Transport d'Energie	Electricity	8 September 1943	Slight fall in output.	Wrong sub-station attacked.

NOTES

1. Thirty-seven items are listed for France for 1943.

	1941												1942											
	M	A	M	J	J	A	S	O	N	D	J	F	M	A	M	J	J	A	S	O	N	D		
AUTOGIRO	○	○									●	●	○	→	X	●	●	●	X					
VENTRILOQUIST											●	●	●	●	●	●	○	X				X		
FAÇADE/TILLEUL							○	●	●	●	●	●	●	●	●	●	○							
HECKLER/SAINT						●																●		
TINKER													●											
URCHIN													X									●		
SPRUCE/GARDENER						●	●	●	●	●	●	●	●	●	●	●	●	●	●	●	●	●		
CARTE						○	○	○	○	○	○	○	○	○	○	○	○	○	○	○	○	○		
CORSICAN							○	X										●	●	●	●	●		
SPINDLE										●	●			●						●	●	●		
PROFESSOR/PEDLAR											●	○												
PRUNUS													●	●										
PLANE													●	●										
CHESTNUT														●	●									
SATIRIST															●	●	●	●	●	●	●	●		
DETECTIVE																●	●	●	●	●	●	●		
PRIVET																	●	●	●	●	●	●		
MARKSMAN																		●	●	●	●	●		
DONKEYMAN																			●	●	●	●		
GREENHEART																	○	○	○	○	○	○		
MONKEYPUZZLE																	●	●	●	●	●	●		
PIMENTO																	●	●	●	●	●	●		
PROSPER-PHYSICIAN																	●	●	●	●	●	●		
SCIENTIST																	●	●	●	●	●	●		
JUGGLER																	○	○	○	○	○	○		
BUTLER																	●	●	●	●	●	●		
ACROBAT																								
INVENTOR																								
HEADMASTER																								
ATTORNEY																		●	X					
WHEELWRIGHT																								
BRICKLAYER																								
MUSICIAN																								
FARMER																					○	○		
BOOKMAKER																					●	○		
FARRIER																						○		
CINEMA-PHONO																								
STATIONER																								
JOCKEY																								
PUBLICAN																								
SALESMAN																								
STOCKBROKER																								
SCULLION																								
PARSON																								
SACRISTAN																								
MONK																								
ARCHDEACON																								
AGOLYTE																								
DRESSMAKER																								
AUTHOR/DIGGER																								
DITCHER																								
NEWSAGENT																								
DIPLOMAT																								
CLERGYMAN																								
GONDOLIER																								

**DIAGRAM SHOWING F SECTION ACTIVITY
IN FRANCE 1941-1944**

KEY

- Connected circuit activity
- Disjointed activity, successful : raids, coups, escapes, making contact, etc.
- Disjointed activity, unsuccessful : failed coups, failed escapes, waiting about, arrests, etc.
- X Circuit commanders arrested or killed in action
- Circuits in action when overrun by allied forces

See caution on page 133

Appendix I:

Table of Dates

To be read in conjunction with Appendix H, page 466

1938	March	Germany takes Austria.	Sections D and EH set up.
	September	Munich agreement.	
	November		GS(R) to study guerilla.
1939	August	Russo-German pact.	
	September	Germany invades Poland; Britain and France at war with Germany; 4 th partition of Poland	
1940	April	Germany takes Denmark and Norway.	
	May	Churchill PM. Germans take Low Countries and attack France.	
	June	Dunkirk evacuation. Italy enters war. De Gaulle flies to London. French sign armistice.	
	July	Mers-el-Kebir fighting. Etat Français replaces 3 rd republic. First gaullist agents in France.	SOE forms under Dalton.

1940	July- September	Battle of Britain.	
	August		Nelson CD. Humphreys F.
	September	Dakar failure	
	December	Great Fire of London.	Marriott F. Humphreys D F. EU/P set up.
1941	March		SAVANNA drops into Brittany.
1941	April	Germans occupy Yugoslavia and Greece.	SAVANNA returns; MO/D, later RE, set up under Piquet-Wicks. First DF and EU/P agents land.
	May	Fighting in Crete and Syria. Communists found Front National.	First F agents land; AUTOGIRO starts.
	June	Germans invade USSR; PCF changes sides.	
	October	Germans sight Moscow.	Most F agents arrested.
	November		Buckmaster F.
	December	Pearl Harbour; Germany declares war on USA	
1942	January	Japanese in Singapore. Main U-boat offensive starts.	Moulin in France. BCRAM forms.
	February	Selborne replaces Dalton.	
	May	British invade Madagascar.	Hambro CD. AUTOGIRO collapses.
	June	Battle of Midway. Germans in Tobruk.	OSS forms.
	July	Germans in Sebastapol	PROSPER and PIMENTO start.

1942	August	Dieppe failure.	Hutchison RF.
	September		SOE/SO set up.
	October	Battle of El Alamein.	
	November	TORCH landings in NW Africa; Germans in SE France. Russian counter-offensive at Stalingrad.	FARMER starts.
	December	Darlan assassinated.	
1943	January	Casablanca conference.	
	February	Last Germans at Stalingrad surrender.	
	May	Germans lose Tunisia.	CNR (Conseil National de la Résistance) formed. De Gaulle moves to Algiers.
	June		Moulin arrested at Caluire PROSPER collapses
	July	Allies invade Sicily.	
	July– November		ARMADA (RF canal sabotage) active; RF air resupply system perfected.
	August	Quebec conference.	
	September	Italy surrenders.	Gubbins CD.
	October		<i>Affaire Grandclément.</i> Dismore RF.
	November	Teheran conference.	
1943/	October/		F and RF treble effective circuits.
1944	April		
1944	March		FFI established.
	April	Russians retake Odessa.	

1944	May		SFHQ and SPOC established.
	June	Allies in Rome. OVERLORD assault.	JEDBURGH and SAS parties to France; innumerable F and RF demolitions.
	July	Attempt on Hitler fails. Americans break into Brittany	EMFFI to command all resistance. Vercors disaster. SAS secure Breton countryside.
	August	Warsaw rising. DRAGOON. Russians in Bucharest.	French national revolt. De Gaulle in Paris.
	September	Allied advance checked near German frontiers.	SOE operations in France wound up.
1945	March	Allies force Rhine.	Germans execute most surviving agents in their hands.
	April	Hitler's suicide.	Concentration camps overrun.
	May	Germany surrenders.	
	July	Attlee PM.	
	August	Atomic attacks on Japan.	
	September	Japan surrenders.	
1946	January		SOE disbands

Notes

PREFACE

1. 693 H.C. Deb 5s, 29–30, 13 April 1964.
2. Patrick Howarth, ed., *Special Operations*, 174. There is a list of books on pages 400–13.
3. Sonnet, xvii. 10.

INTRODUCTION

1. There is a table of dates at Appendix J, page 468.
2. The Italians occupied the south-eastern corner of France from November 1942 to September 1943. But their impact on resistance there was slight, and normally – as above – the text ignores them.
3. These views are amply illustrated in *Foreign Relations of the United States*, 1943, II (Europe).

CHAPTER I

1. Quoted in a paper of recommendations on control of para-military activities, 5 June 1939, M I R file 3. MIR files are now at HS8/256–61.
2. *Report and Lessons from Certain Activities*, I, some eight thousand words long, November 1946; in an SOE file not yet available.
3. MIR files; private information.
4. *Times* obituary of him, 10 June 1961.
5. Churchill, *Second World War*, II, 148–50.
6. MIR file 8.
7. SOE, *History*, III, devices section, appendix A, I (several of these typescript section histories are later referred to as *History* with a volume number: see p. 397 for details). Technical details of fuses are in an SOE file.
8. Report by head of section D, 10, cited in note 2 above; and MIR file I, items 1 and 2.
9. MIR file 1, item 3.
10. Report No. 8 to DCIGS, 2, MIR file 3.
11. *Art of Guerilla Warfare*, 10; in MIR file 1, item 9. See below, pp. 247, 347–8, 356, etc.
12. In Foot, *SOE in the Low Countries* (2001), 445–72.
13. Leproux, *Nous, les terroristes*, I, 278–88.

14. *Report* by its head, November 1946, cited in note 2 above; and *Times* obituary of M. R. Chidson, 4 October 1957.
15. Conversation with him, 21 September 1967.
16. For an account of Grand's appearance, manner, and methods, see Sweet-Escott, *Baker Street Irregular*, 20–1.
17. *Report* cited in note 2, 15.
18. *History*, XXIII (iv), section D, Paris office, 5–33, HS7/3.
19. See his *Foreign Fields*.
20. *History*, XXIII (iv), 34–7.
21. MIR war diary, HS8/263, 11 June 1940, file 2. No reports survive; nor is there any trace in MIR's or SOE's or CCO's files of an adventure in Guernsey bracketed by Churchill with the one at Boulogne (*Second World War*, II, 572).
22. Undated reports, MIR file 5.
23. MIR file 6, reorganization.
24. MIR war diary, 12 June 1940, file 2; now at HS8/263.
25. MIR file 6, reorganization.
26. See his *The Supreme Command* (1961), I, 325.
27. Draft minutes approved by Halifax on 2 July 1940; when Cadogan sent a copy to Duff Cooper, with an apology for having forgotten to ask him to the meeting (MIR. file 10).
28. MIR file 10; part quoted, without a date, in Dalton, *The Fateful Years*, 368. Contrast Boltin and Redko, *Voenna-Istoricheskii Zhurnal*, September 1964, 15.
29. Dalton, *The Fateful Years*, 379.
30. Appendix C to secret memorandum by DMI, 18 July 1940.
31. Dalton, *The Fateful Years*, 366.
32. MIR. file 6, reorganization.
33. Conversation with him, 1969.
34. 22 August 1941, in Garnett, *PWE*, 79.
35. Minute by Jebb, 5 September 1941, in an SOE file. There had been a comparable struggle in Germany, on a similar subject, between Ribbentrop and Goebbels; see Marcelle Adler-Bresse in *Revue d'histoire de la deuxième guerre mondiale*, January 1961, 44.
36. Garnett, *PWE*, 40.

CHAPTER II

1. *History* IVB, security; Appendix A, 4, HS8/832.
2. Dalton, *The Fateful Years*, 366.
3. E.g. his *Defence of the West* (1950), chapter 7. And see pages 366–70 below.
4. Note by Sporborg, 9 November 1945, in *History* LXII (i), correspondence. Compare pages 71–4 below.
5. See, however, pages 161–2 below.
6. Dalton to Attlee, 4 July 1940 (since destroyed).
7. See Duff Cooper. *Old Men Forget*, 321–2.
8. Obituary in *DNB 1961–1970*, 788–9.
9. Obituary in *ibid.*, 876–7.
10. Dalton, *The Fateful Years*, 288. See Wilkinson and Astley, *Gubbins and SOE* (1993).
11. Dalton, *Call Back Yesterday* (1953), 220. Jebb later became Lord Gladwyn.
12. Dalton, *The Fateful Years*, 369.
13. Jebb to Cadogan, 6 May 1942, 6; in an SOE file.
14. Dalton, *The Fateful Years*, 368; Vansittart, *Mist Procession* (1958), 550. And see *DNB 1981–1985*, 380–1.
15. See Piquet-Wicks, *Four in the Shadows*, 19; and SOE war diary, 512, 5–6 April 1941, HS7/2150.
16. Secret memorandum by DMI, 18 July 1940, and MIR war diary, 24 July 1940.
17. War diary, 60, HS7/212.
18. See Passy, 135. Barry's account of SOE's objects and achievements is in *European Resistance Movements 1939–45*, I, 340–56.
19. See page 74 below.

20. See *DNB 1971–1980*, 573–4.
21. History XXIII (iv), section D, Paris office, 37–41, HS7/3; private information.
22. War diary, 25, 3 December 1940, HS7/211. Passy, 135, and Piquet-Wicks, 18, wrongly put Thomas Cadett at the head of F section: Cadett served in it for fifteen months, moving to the BBC in March 1942 (Cadett PF and private information).
23. See pages 161–2.
24. Cf. Passy, 176.
25. Webster and Frankland, *Strategic Air Offensive*, i, 399.
26. See pages 138–41 below.
27. War diary, 26, HS7/211.
28. Piquet-Wicks, 20–1; photograph at 33; tablet now on wall in Dorset Square.
29. PF's on the officers named; Piquet-Wicks, 70; and Passy, 294–5. Hutchison later sat in parliament and was granted a baronetcy for political services. His adventures in the field are noted on pages 355–6 below. Postwar photograph in *Times House of Commons*, 1951, 191. See also Sweet-Escott, *Baker Street Irregular*, 107–11, 178–86.
30. Passy, 61–3. See his *Times* obituary, 22 December 1998, 19c; and *Colonel Passy*, ed. J.-L. Cremieux-Brilhac, his memoirs; and a life of him by A. Perrier (2000).
31. Conversations with Dewavrin, 1969, and Buckmaster, 1984.
32. Passy, 213–16, 218–19, 294–7, with organization diagram at 296; conversation with Dewavrin, 29 June 1966.
33. Noguères, *Histoire de la Résistance*, II, 43n.
34. *History*, XXIA, EU/P, I, I, HS7/184.
35. *Ibid.*, I, 4.
36. Hazell to CD, 4 June 1945, in his PF, HS9/653.
37. Michel, *Histoire de la Résistance*, 124, n.
38. See note on books at Appendix A, page 398.
39. Dansette, *Libération de Paris*, 37, cites de Vogüé's application of this figure to French resistance in general.
40. Note in SOE file, 4 January 1943.
41. C. B. Lucas Phillips, *Cockleshell Heroes (1956)*; see pages 166, 180 below.
42. *History*, III, false document section; unnumbered page.
43. Obituary in *Times*, 4 August 1960.
44. Mackenzie, 723.
45. Paper on 'German penetration of SOE', December 1945, 7; top secret; copy in History, IVB, security. And see Buckmaster, *Specially Employed*, 59. Piquet-Wicks did not serve clandestinely either.
46. See Passy, *Souvenirs*, 515–98.
47. Marshall, *The White Rabbit*, and Seaman, *Bravest of the Brave*, recount in gruesome detail Yeo-Thomas's adventures and his eventual escape from Buchenwald. See also *DNB 1961–1970*, 1120–1.
48. Levin interrogation, 24 January 1945, 21. For the vic line see pages 90–1, 169–70, etc., below.
49. Hermione Ranfurly, *To War with Whitaker* (Mandarin 1995), 81–2, describes an incident in Cairo in 1941 that cannot have prejudiced Eden in favour of SOE.
50. Organization for joint planning, Command 6351 (1942), chart, n i, *Parliamentary Papers*, 1941–42, IX, 569.
51. Selborne to Eden, draft on political ambitions of French secret services, 24 November 1943; HS8/902.
52. Cf. Michel, *Mouvements clandestins*, 29–33.
53. Compare Appendix F, page 447.
54. The American OG's are not included in these figures; they all went in after D-day.
55. Compare Marshall, *White Rabbit*, 41, and Giskes, *London Calling North Pole*, 42.
56. See below, pages 145–6, etc.; Reitlinger, *The SS*, 229; and Michel, *Mouvements clandestins*, 35–37.
57. For details of supplies sent into France see Appendix C, page 419.
58. War diary, 341, HS7/214.
59. Page 17 above.
60. But see Sweet-Escott, *Baker Street Irregular*, 137–44, 153.
61. Bernard Victor Moore II, *The Secret Air War over France: USAAF Special Operations Units in the French Campaign of 1944* (Maxwell Air Force Base, AL: Air University Press, 1993) a fifty-page pamphlet, sets out lucidly the air political obstacles that lay in the way of making this contribution available at all, and summarizes the results.

62. *History*, XXIVA, RF section, 1944, 39, HS7/124.
63. SAS troops and JEDBURGHs have sometimes been accidentally confused: e.g., Minney, *Carve Her Name with Pride*, 126. JEDBURGHs and SUSSEX parties, equally distinct, can be confused also: Baudot, *Opinion publique*, 135, 177. For SUSSEX, also no part of SOE, see page 359 below.
64. Note by Senter, SOE's director of security, 1942–45, 31 December 1945, 3; prefixed to *History*, IVB, security section, HS8/320.
65. SOE file.
66. *Ultra Goes to War* (Hutchinson 1978), 18–19.
67. Hinsley, *British Intelligence*, ii, 668.
68. *Voenno-Istoricheskii Zhurnal*, September 1964, 25, trans. R. Jacoby. And cf. page 382 below.
69. Most secret note for the defence committee of the Cabinet, 11 January 1944.
70. War diary, 2, HS7/211.
71. *History*, IV, administration, Appendix IIA, 6–7; War diary, 1233.
72. *History*, IV, Appendix II A, 2–3.
73. H. Peulevé report, 23 April 1945.

CHAPTER III

1. War diary, 3, HS7/211.
2. For one or two possible examples, see pages 115 and 215–16 and Chapter x.
3. Millar, *Horned Pigeon*, 314, 322–3.
4. *History*, III, false documents section, 4–5.
5. *History*, VIII, SOE agents' ciphers, HS7/45, *passim*.
6. SOE to MI 1, 25 March 1942, in Jepson, PF, HS9/796.
7. Examples of his interview techniques are to be found in Overton Fuller, *Madeleine*, 59–62 and Minney, *Carve Her Name with Pride*, 59–69; Buckmaster, *Specially Employed*, 151, and Minney, *Carve Her Name with Pride*, 59–61, describe the dreary rooms he worked in. Tickell's account, *Odette*, 69–78, is suspect.
8. In Greece and Yugoslavia the most senior agents were brigadiers, working to brigadiers in Cairo.
9. A/CD to CD, 29 July 1944, in J. E. Redding, PF, HS9/1238.
10. *History*, IXE, air operations, 223–5, HS7/9.
11. Personal knowledge; and see *Dictionary of National Biography, 1941–50*, 880 and HS9/1463. See also Sweet-Escott, *Baker Street Irregular*, 205–6, 211–13.
12. *Who Lived to See the Day*, 278.
13. F/ADM to D/AIR, 12 December 1944, in Southgate PF, HS9/1395. See pages 334–5 below.
14. *History*, XXIV, H, report of JUDEX mission, HS7/134. He was promoted full colonel to conduct it.
15. Sherlock Holmes's interview with a thinly disguised Mr Gladstone during his adventure of 'The Second Stain' is the *locus classicus*.
16. Cf. Siegfried Sassoon, *Memoirs of an Infantry Officer* (1930), 72.
17. Millar, *Maquis* (2 edn), 14.
18. Contrast Lodwick, *Bid the Soldiers Shoot*, 166.
19. MIR file 7; *History*, IV, administration.
20. Paper on 'German penetration of SOE', December 1945, 9; copy in HS8/8320.
21. See Haukelid, *Skis against the Atom* (1955 edn) 58–60 for an example.
22. *Men in Uniform* (1961), 158–9.
23. Overton Fuller, *Double Agent?*, 25.
24. Her photograph is in Larroque, *Pauline*. Citations and correspondence in her PF, HS9/355, 356. She was given an MBE (Mil) by the Air Ministry.
25. Lise de Baissac: Ward, *F.A.N.Y. Invicta*, 217.
26. 408 HC Deb 5s 1860, 6 March 1945
27. Appendix B, page 414.
28. *Times* obituary of Sir D. Bowes Lyon, 14 September 1961; MIR war diary, July 1940.
29. Minney, *Carve Her Name with Pride*, 77, placed him in Scotland; Churchill, *Of Their Own Choice*, 29–30, in the New Forest. Both were right, he moved.
30. J. D. A. Makgill, PF, HS9/978.
31. Lord Howard of Penrith: see page 168 below on AQUATINT.

32. Usually, but wrongly, spelt 'Boddington'.
33. *Who's Who*; PFs, private information.
34. PFs on the agents concerned.
35. She worked for VAR; whose organizer had to buy her shoes himself. Lecorvaisier interrogation 2, Danielle Marion, PF, and private information.
36. There is another account of Trotobas' end in Buckmaster, *They Fought Alone*, 149–51, too beautiful to be true. This is from *Olivier's* PF. See pages 237–9 below.
37. Miliar, *Horned Pigeon*, 323.
38. De Vomécourt, *Who Lived to See the Day*, 24; echoing de Gaulle's original proclamation of June 1940.
39. *History*, XXXI, X section, chapter Vc, part II, 4; 17 July 1945, HS7/145.
40. PF's on the agents concerned; Millar, *Horned Pigeon*, 322; *Maquis*, 342.
41. Paper on 'German penetration of SOE', December 1945, 9; top secret, copy in, HS8/8320.
42. Paper by D, 14 April 1940, in an SOE file.
43. E.g. CFR (40), 46th meeting, item 1, 22 August 1940; CFR (41), 17th meeting, 24 February 1941; Piquet-Wicks, 28.
44. Paper of 17 June 1941 in an SOE file.
45. Buckmaster, *They Fought Alone*, 127. He might have remembered Lawrence's *Seven Pillars of Wisdom*. His *Specially Employed*, 25–35, describes the training system plainly.
46. Wanborough's atmosphere and syllabus are described in the opening pages of Peter Churchill, *Of Their Own Choice*, there is a photograph in Minney, *Carve Her Name with Pride*, 92.
47. Dourlein, 81
48. See Fairbairn and Wallbridge, *All in Fighting*.
49. Langelaan, *Knights*, 68.
50. DSR. to AD/Z, 30 March 1942, most secret, in an SOE file.
51. A. M. Walters, *Moondrop to Gascony*, 103.
52. A Yugoslav partisan ate some also, 'mashing it up with milk, under the impression it was some kind of maize porridge' (Fitzroy Maclean, *Eastern Approaches* (Cape, 1949), 437). All three survived unharmed.
53. See photograph in R. N. Gale, *6 Airborne Division* (Low, Marston, 1948), at 48.
54. See page 113 below.
55. Churchill, *Of Their Own Choice*, 31.
56. See Buckmaster, *Specially Employed*, 18–20, and Millar, *Maquis*, 6–8. There was an entertaining caricature of the school in Mille Bardot's film, *Babette Goes to War*.
57. *London Calling North Pole*, VI, and Giskes interrogation summer 1945, in his PF.
58. And see Shirer, *Third Reich*, 273, for the prewar composition of the *Sicherheitsdienst*.
59. Colonel Pierre Lorain, ed. David Kahn, *Secret Warfare*; Mark Seaman, ed., *Secret Agent's Handbook of Special Devices*.
60. E.g. Piquet-Wicks, 145–6.
61. All the training section's files seem to have been burnt, though hundreds of reports on individual agents survive. There is a useful section history, on which the training passages in this chapter are mainly based; they rely also to some extent on the numerous accounts in agents' memoirs.
62. E.g. Green to Dismore; 11 October 1944, in HS6/359.

CHAPTER IV

1. Paper of 17 June 1941, in an SOE file.
2. Georges Delfanne, alias *Masuy*, quoted in Rémy, *Une Affaire de trahison*, 45, tr.
3. Hytier, *Two Years of French Foreign Policy*, 106.
4. Brook to Foreign Office, 16 November 1964.
5. Brooks Richards, *Secret Flotillas* (HMSO, 1996).
6. RF/P to RF, 1 March 1944, in an SOE file.
7. Harratt interrogation, 15 December 1944, 8–9, HS6/572.
8. 21 August 1940, copy in an SOE file.
9. In an SOE file.
10. *History*, X, naval section; HS7/23, 'Notes on para-naval operations', 24 August 1943, 5–6.
11. E.g. D/NAVY to F, 18 March 1941, in an SOE file.

12. Churchill, *Of Their Own Choice*, 50–76, and *Duel of Wits*, 15–35, describe typical submarine operations in workmanlike detail; d'Astier, *Seven Times Seven Days*, 63–70, recounts one of them with poetic vividness.
13. Passy, 85.
14. DF to AD/E, 14 February 1944, copy in an SOE file.
15. Bevil Warington-Smyth, 'Short History of SOE Naval Base at Helford River', 12 February 1946, in *History*, X, I.
16. *Ibid.*
17. Holdsworth to Mackenzie, 25 April 1942, in an SOE file.
18. A list of available craft and their performances is in DRP/30I of 4 February 1944, in an SOE file.
19. *History*, X, ch. I.
20. DDOD(I) to NID(Q), 19 May 1943, in an SOE file.
21. *Ibid.*, and report on exercise MANACLES, 5 January 1944, in an SOE file, and 'Notes on surf landing' by Warington-Smyth and Whalley, 15 October 1942, in another.
22. *History*, II, training, 28–9.
23. DRP/30I of 4 February 1944 in an SOE file.
24. Confirmed in an Admiralty letter of 1 June 1943, most secret; copy in *History*, X, ch. II, Appendix B.
25. Photograph in Richards, *Secret Flotillas*, before 269.
26. *History*, X, Warington-Smyth's paper, 6–7. The rescue was named FELICITATE. Lavish details in Richards, *Secret Flotillas*, 199–217.
27. Minutes in an SOE file.
28. The amalgamation was arranged between DDOD(I) and D/Navy on 30 March 1943 (minutes signed that day by DDOD(I), in an SOE file).
29. *History*, X, Warington-Smyth's paper, 5.
30. Some details of the few stores operations carried out by sea will be found in Appendix C, pages 420–1.
31. Harratt interrogation, 15 December 1944; Buckmaster, *Specially Employed*, 189.
32. 'They never', Gubbins added, 'gave me any trouble' (private information).
33. Conversation with Frenay, 1969.
34. *History*, XXXVI, H section, 15.
35. Popular accounts of incidents from felucca operations into the south of France can be found in Tickell, *Odette*, 131–6 and Overton Fuller, *The Starr Affair*, 29–31. More details are in Richards, *Secret Flotillas*, 453–544.
36. Traces of this are in D/Navy to CD, 18 October 1942, in an SOE file; and in *History*, XXIA, EUP section, V.2, HS7/184. And see page 185 below.
37. Michel, *Histoire de la Résistance*, 52.
38. Photograph in Richards, *Secret Flotillas*, before 357.
39. Croft, PF. Photograph in Richards, *Secret Flotillas*, at 557; and see Andrew Croft, *A Talent for Adventure* (Hanley Swan, SPA, 1991)
40. Plenty of nautical detail in Richards, *Secret Flotillas*, 218–39.
41. Tout to D/Navy, 20 April 1943, in an SOE file.
42. SOE files.
43. Most SOE agents had one alias and one field name at least; Deman, like many engaged in several operations, had several. In future the field name most often used by an agent will be given, as above, in italics after the first mention of his name.
44. Deman PF, Harratt PF (HS7/666) and interrogation, 15 December 1944. For the S-phone, see pages 79–80 below. Deman had an obituary in the *Independent*, 3 December 1998.
45. The same beach had been used for similar purposes in the 1790s (conversation with M. G. Hutt, 25 August 1966).
46. Deman and Harratt interrogations. These also provide the main source for the following paragraphs, supplemented by SOE files bearing on the details of operations.
47. See pages 88–94 below.
48. Draft DF section history, 47, in *History*, XXIVC.
49. See page 102.
50. Harratt interrogation, 6.
51. BBC broadcast on Helford, 23 October 1962.
52. Draft DF section history, 47, in *History*, XXIVC.

53. *Ibid.*, 49.
54. Sicot was also sometimes known by his own first name of *Aristide*; this was the code name of Roger Landes, head of a busy and successful F section circuit at Bordeaux, of an RF section Lysander organiser, Aubinière, and of Bourdon, the French officer in JEDBURGH team QUININE. The four should not be confused.
55. Operational orders for Deman, 16 May 1944, in an SOE file.
56. Robert Graves, *The Greek Myths* (Penguin, 1955), i, 230, 303.
57. F. O. Miksche, *Paratroops* (1943), 17.
58. For his initial hesitation, see page 140 below.
59. *History*, IXA, Appendix I, 3. In July 1943 the proportion of SOE to other clandestine air sorties was variously estimated by the chief of the air staff as fifteen to one, and by CD at seven to one.
60. Webster and Frankland, II, 3, 92, etc.; photograph at II, 158.
61. *History*, IX, 143–9. For lively details on Tempsford and its work see Tickell, *Moon Squadron*. There is a detailed account of CARPETBAGGER, the American activities in this field, in W. R. Craven and J. L. Cate, *The Army Air Forces in World War II*, iii, chapter xiv (Chicago, 1951).
62. Thomas L Enslinger has embarked on *Spies, Supplies and Moonlight Skies* (Fairborn, Ohio; Hillridge) – the first volume, covering early 1944, came out in 2001 – which promises to cope in minute detail with these USAAF operations.
63. *History*, IX, Appendix 5, 7.
64. See page 102 below.
65. Photograph in R. N. Gale, *6 Airborne Division* at 8–9.
66. Personal knowledge.
67. Cowburn, *No Cloak, No Dagger*, 12–13, 146, may be picked out as authentic.
68. Piquet-Wicks, 142.
69. Passy, 132, tr.
70. Rouxin interrogation, 14–15 July 1944, I. Orabona's PF has been destroyed.
71. Malfettes, PF, HS9/979.
72. SOE files VEGANIN, IVOR, HS6/563, 528.
73. SOE file.
74. This figure excludes OGs.
75. Jumeau PF and Choremi interrogation, 6 October 1944, HS9/815/4 and 9/308.
76. Peulevé PF, HS9/1178/6; Buckmaster, *They Fought Alone*, 112–24, largely fanciful.
77. SOE file ARTHUR, HS6/482.
78. Sheppard PF, citation. HS9/1353. Photograph in Gordon Young, *In Trust and Treason*, at 160.
79. This story may have originated from an adventure of Pierre de Vomécourt (*Lucas*) who did land in a tree on All Fool's Day 1942, but soon reached ground.
80. See Appendix C, supply, page 423; contrast Aron, *De Gaulle Triumphant*, 117.
81. *History*, IXB, container notes, and IX, drawings; a C-type container and one cell of an H type are shown in Servagnat, *La Résistance*, at page 46.
82. *History*, XXIIV, HS7/169, 1944, Appendix A, 4. MASSINGHAM.
83. On one such occasion the groundlings assumed, wrongly, that the aircraft had accidentally dropped a couple of small bombs, overlooked in its bomb bay after its last raid on Germany (Guillaume, *La Sologne*, 65).
84. *History*, IX, Appendix 8, 4, and IXB, packing station, 3; 138 Squadron ORB.
85. To be distinguished of course from Roger Bardet alias *Chaïllan*, as from Roger Landes alias *Aristide*, of both of whom more later.
86. Cammaerts interrogation, 16–18 January (1945), 16, HS9/258.
87. SOE to MASSINGHAM, 19 April 1944, decipher teletype, quoting recent JOCKEY message. Cammaerts PF, HS9/258.
88. *History*, XXIIV, MASSINGHAM, III, 2. HS7/169
89. Wooler PF. HS9/1620.
90. 'Brief history of the planning and supply of air dropping equipment', 18 September 1945, in *History*, IXB.
91. 418 Squadron ORB, HJR27/1821, January, February 1944, *History*, IXB, packing stations, 6.
92. 'Reception committee drill' in *History*, II, training; illustrated in *School for Danger*.
93. Robert Benoist interrogation, 10 February 1944, 6. HS9/128.
94. E.g. Churchill, *Duel of Wits*, 303–9.

95. *History*, Vc, radio communications division, HS6/133; photographs in Servagnat, *La Résistance*, at 50, and in *School for Danger*, with a good example of its tactical value.
96. Quoted in *ibid.* from *History*, IXE, 170–1.
97. *History*, XXIVA, RF section, 1943, 55; 1944, 22, HS6/123–4. And see page 294 below.
98. Craven and Cate, *Army Air Forces*, III, 519; Soustelle, II, 387, mentions Joseph Kessel as one of the pilots involved.
99. *History*, IXE, 217, based on ORBs; contrast Webster and Frankland, *Strategic Air Offensive*, II, 156; see also *ibid.*, I, 399, II, 110, 193–4, III, 286–7, etc.
100. 400, HC Deb, 5s, 1860, 6 March 1945.
101. *History*, IX, 165–6. For a detailed account of the navigating problems, written from the point of view of a pilot who had to map-read for himself, see appendix D, page 427 below.
102. *History*, IXE, 168.
103. See, for example, de Vomécourt, 96–97.
104. This somewhat pathetic tale is summarized in *History*, IX, 168–9; the messages exchanged on the subject with the field have disappeared, and it hardly figures in returned agents' interrogations.
105. *History*, IX, 169.
106. A gamekeeper's permit is illustrated in Buckmaster, *Specially Employed*, at 144.
107. Craven and Cate, *Army Air Forces*, III, 503–5.
108. *History*, IXE, 214–17, and appendix H1, H2.
109. A vivid example of the sort of confusion that could result is in Millar, *Maquis*, 32–60, Chapter X of Cowburn's *No Cloak, no Dagger* gives an excellent account of a typical arms drop.
110. For details, see pages 301–3 and 360 below.
111. G. S. Hebron in *History*, IXA, air liaison, Appendix 5(i), i. HS8/434
112. Photograph in Rémy, *Silent Company*, at 44, and elsewhere.
113. See H. J. Parham and E. M. G. Belfield *Unarmed into Battle* (Winchester, Warren, 1956), 9, 17.
114. Helicopters were considered for this sort of work in 1943; but they were then too noisy and too short ranged (personal knowledge).
115. In *Livre d'Or de l'Amicale Action*, revision slip.
116. *History*, IXA, Appendix 5, and ORB of 161 Squadron, AIR 27/1068.
117. Private information.
118. *History*, IXE, 190. Medmenham's work is described in C. Babington Smith, *Evidence in Camera*.
119. *History*, IXA, Appendix 5(iv), 1–2 (duplic).
120. The account of Lysanders landing cross-wind in Barry Wynne, *Count Five and Die*, 85, is pure romance; as is Churchill's suggestion that four-engined aircraft were used for pick-ups (*By Moonlight*, 2nd edn, 43–4). Minney is no more correct in describing a Lysander 'With the engine switched off' for 'a few minutes' as it came in to land (*Carve Her Name with Pride*, 104). The whole drill is clearly, if briefly, shown in *School for Danger* and described in Leproux, *Nous, les terroristes*, I, 272–5.
121. *Duel of Wits*, 197.
122. *History* IX, A, Appendix 5(iv), 8.
123. *History*, IXE, Appendix 5(ii); and G. R. Starr PF, HS9/1407. See also A. M. Walters, *Moondrop to Gascony*, 257.
124. Talk with him at memorial service for Verity, 5 January 2002.
125. *No Cloak, no Dagger*, 135–41.
126. She figures prominently in Millar, *Horned Pigeon*. See her *Full Moon in France*.
127. *History*, IXA, Appendix 5(i); PF's on agents named.
128. Hoare, 266, 30.
129. Draft DF section history, 21, in *History*, XXIVC.
130. *History*, III, false papers section, 5.
131. The example is taken from the vic line; Mitterrand interrogation, 6 February 1945, 8.
132. This is another vic example; from Gerson interrogation, 13 March 1945, 6, and Levin interrogation, 24 January 1945, 9.
133. Lecorvaisier interrogation, 17 January 1945, 4.
134. See pages 288–90 below.
135. VM to DF, 12 February 1943 in an SOE file. The man to whom these words were to be used thought he was helping – 'purely as a commercial proposition' – to smuggle lovers to a nymphomaniac tired of Spaniards; *Sally* being the field name of Strugo, the man to whom they were being passed. Strugo promptly dropped him.

136. Mitterrand interrogation, 10. The pause in the key sentence is an ancient device, dating back in this context at least to the 1890s: see Rudyard Kipling, *Kim* (1901), end of Chapter X.
137. Mitterrand interrogation, 5.
138. Levin interrogation, 7.
139. Mitterrand interrogation, 7.
140. DF to HX, 2 January, 1943, in an SOE file.
141. See, for example, the adventures of JOSEPHINE, PILCHARD, SCULLION and the German, *Arnaud*, below.
142. Private information.
143. *Hugh Dormer's Diaries*, 62; and see *ibid.* 25–36, 106–20.
144. E.g. Chalmers Wright interrogation, 21 July 1943, 4, in his PF, HS9/1622.
145. See the interesting and vivid account of his wanderings south of Perpignan in *Horned Pigeon*, 374–425; see also Anne-Marie Walters's adventures in the closing pages of *Moondrop to Gascony*.
146. Sevenet interrogation, 6, 28 May 1943, in his PF, HS9/1346.
147. 'Organization VIC: The Service as it stands to-day', a paper drawn up by Gerson in London in January 1944, in an SOE file.
148. Gerson interrogation, 4; Lodwick, one of his less reputable passengers found the journey positively straightforward (*Bid the Soldiers Shoot*, 186–8).
149. Gerson interrogation, October 1943, 10–12.
150. Conditions in Miranda are described in some detail in Madelaine Duke, *No Passport*, 179–85, and in Langelaan, *Knights*, 177–90.
151. Interrogation, 21 July 1943.
152. D/CE.G to HH, 22 December 1942, in an SOE file; and Virginia Hall report, 18 January 1943, in her PF, HS9/647/4.
153. Citation for MC, HS4/236.
154. See Hoare, *Ambassador on Special Mission*, *passim*.
155. Martelli, *Agent Extraordinary*, 85.
156. *Special Operations Executive*, an undated post-war paper, 5–6.
157. See pages 66, 79–80 above.
158. Photograph in John D. Drummond, *But for These Men* (1962), at 112. So many of these sets were made that hundreds were eventually sold off as government surplus stores. See Lovain, 54–5.
159. *History*, V, signals: equipment, 2, 4; NW Europe, 2. HS6/133.
160. Photograph (65) in d'Astier *Paris*. Wiring diagram in Lovain, 56–7.
161. Staggs, PF, HS9/1402/7.
162. So JEDBURGH teams in training were told, in an SOE context; Brome, *The Way Back*, 54–5, tells the same tale of an escape line.
163. O'Sullivan interrogation, autumn 1944, in P. E. Mayer, PF, HS9/1011/7.
164. *History*, Ic, camouflage.
165. Langelaan, *Knights*, 220.
166. Passy, 315.
167. Paper on 'German penetration of SOE', December 1945, 10; copy in *History*, IVB, security.
168. Passy, 315–21.
169. Report by Bodington, September 1942, 45, in an SOE file.
170. HarperCollins 1998.
171. David Kahn, *The Codebreakers*, 402–3.
172. Robin Denniston, *Churchill's Secret War* (Stroud: Sutton, 1997), 25.
173. Page 216 below.
174. Undated staff note, probably 28 March 1944, in an SOE file.
175. It was referred to by the Crown in the *Lonsdale* trial, as in use by the Russian secret service: *The Times*, 9 February 1961, 7.
176. E.g. Peulevé report, 23 April 1945, I.
177. See especially pages 291–307.
178. Nicholas, *Death be not Proud*, 115.
179. D/CE, G to D/CE, 15 September, in an SOE file.
180. Teleprint in Claude Malraux, PF, HS9/980.
181. War diary, May–October 1941, HS7/216–21, is crammed with references to messages from him in which the security check was either wrong or omitted.
182. Warden to Boyle, 1 February 1945, in J. A. R. Starr, PF, HS9/1406/8.

183. Giskes, *London Calling North Pole*, 69, 94; details in Foot, *SOE in the Low Countries*.
184. See pages 236–7 below.
185. See pages 301, 201–2 below.
186. *They Fought Alone*, 69.
187. Paper on ‘German penetration of SOE’, December 1945, 14 and Appendix C, 6; top secret, copy in *History*, IVB, security, HS8/832.
188. H. W. Steed, *Through Thirty Years* (1924), II, 43–45; Ezra Pound, *Cantos*, xix, 43–54.
189. See page 149 below.
190. For details see pages 270–1, 341–2 below, where the whole problem of these blocks of ‘action’ messages receives some further notice.
191. Quoted by Rossi, *Communist Party in Action*, 164, from the communist *Vie du Parti*, second quarter; 1941, 9–10; trans. Kendall.
192. See pages 275–6 below.
193. E.g. pages 153–4 below; or Cowburn, *No Cloak, no Dagger*, 24–5.
194. Overton Fuller, *Starr Affair*, 40.
195. R. A. Chapman interrogation, 9 January 1945, 10. HS6/588.
196. See page 296 below.
197. ‘Where can one get lighter fuel?’ ‘Petrol, you mean?’
198. Example on page 296 below.
199. The elaborate diagram of one of these networks in Buckmaster, *Specially Employed*, 89, is taken from *History*, XXIVH, JUDEX mission.

CHAPTER V

1. Paper on ‘German penetration of SOE’, 16; top secret, December 1945; copy in HS8/832.
2. *The Lord of the Rings* (1954), II, 171.
3. Photograph in *History Today*, VIII, 559, August 1958.
4. See *Colonel Henri’s Story*, edited by Ian Colvin, esp. 104.
5. This account relies on Reitlinger, *The SS*, especially 31–53, 208–10, on various captured Germans’ interrogations, and on secret files.
6. Nuremberg trial, XXII, 473–7.
7. *Ibid.*, 477–81.
8. See Schnabel, *Macht ohne Moral, passim*; and pages 373–9 below.
9. Rühl and Placke interrogations make this clear; in spite of Yeo-Thomas’s impression to the contrary (Overton Fuller, *Born for Sacrifice*, 12–13).
10. Listed in Placke interrogation by Americans, May 1945, in his PF.
11. Photograph (27) in d’Astier *Paris*.
12. Goetz later became director of education for Land Baden. It would be interesting to know how he managed to get denazified.
13. Aubin of WHEELWRIGHT and AUDITOR, and Corbin of SCIENTIST and CARVER.
14. Aron, *De Gaulle before Paris*, 88–91.
15. *Maquis*, 2nd edn, 40.
16. Michel, *Jean Moulin*, 40, tr.
17. *History*, LXXII (ii), odd note of March 1945.
18. *History*, XXVIA, Belgium, supplementary second chapter, 13. HS7/100.
19. Cowburn interrogation, 20 December 1944, 6.
20. Flattot interrogation, 17 January 1945, 7.
21. Southgate report, April 1945, in HS9/1395. Everyone had his own danger signal. The usual ones were extremely simple – a particular shutter open or closed, a twist of wool round the handle of a door, a duster lying on a window-sill, and so on.
22. Cowburn, *No Cloak, no Dagger*, 173–4.
23. Zembsch-Schreive PF, HS9/1329/2, and SOE files. See his *Pierre Lalande*.
24. Private information.
25. *Hugh Dormer’s Diaries*, 107.
26. Peulevé report, 23 April 1945, in his PF, HS9/1178/6.
27. Report by Warden on visit to Fresnes, 27 January 1945, 3, copy in J. A. R. Starr, PF, HS9/1406/8.

CHAPTER VI

1. Woodward, *British Foreign Policy*, 66; text in Churchill, *Second World War*, II, 183–4.
2. Spears, *Catastrophe*, II, 69–70, 291.
3. *Ibid.*, 304, 311–14, 318–23; Churchill, *Second World War*, II, 192.
4. Woodward, *British Foreign Policy*, 75.
5. *Ibid.*, 76–7. And see Michel, *France libre*, 8.
6. Churchill College Cambridge, CHAR 20/13.
7. Sumner Welles, *Seven Major Decisions* (1951), 49.
8. Woodward, *British Foreign Policy*, 76.
9. Soustelle, I, 19–20.
10. Talking to Spears, 6 June 1940: Spears, *Catastrophe*, II, 84.
11. Welles, *Seven Major Decisions*, 50.
12. See François Goguel, *La politique des partis* (du Seuil, 2v, 1946).
13. Private information. Contrast Michel's unfounded reference to 'agents arriving from London with suitcases full of currency notes, genuine or forged': *Histoire de la Résistance*, 95 tr.
14. E.g., Michel, *Histoire de la Résistance*, 31.
15. Cf. Michel and Mirkine-Guetzévici, «*Idées politiques et sociales de la Résistance*» and Michel, *Courants de pensée*.
16. Cf. Marcel Proust (trans. C. K. Scott Moncrieff and T. Kilmartin), *Remembrance of Things Past* (1989), II, 731–9.
17. SOE file, ANDY, HS6/476.
18. Daniel Halévy, *La République des Comités* (Grasset, 1934).
19. 1 July 1940.
20. *Histoire du Parti Communiste français*, II, 24–28.
21. Churchill, *Second World War*, II, 162; 'He remained impassive'.
22. *Cahiers de l'Iroise*, Oct.–Dec. 1961, 234; *Irish Times*, 25 February 1965.
23. *Second World War*, II, 451.
24. Francis Williams, *A Prime Minister Remembers* (Heinemann, 1961), 56.
25. Passy, 72–5; cp. *ibid.*; 368, an unsolicited testimonial from Brossolette.
26. From HS7/133.
27. Hostache, *CNR*, 22–3.
28. *Second World War*, II, 450.
29. Xavier de Bourbon, *Accords secrets franco-anglais*, summarizes much other literature, including a hotly worded white paper denying the existence of any agreement (Cmd. 6662 in *Parliamentary Papers* 1945–46, XXV, 171).
30. Spears, *Catastrophe*, II, 333.
31. E.g. pages 204, 339–40 below.
32. Passy, 136, 127n.
33. *No Cloak, no Dagger*, 108–9.
34. Speech in Westminster Abbey, 21 May 1948.
35. *Sea Warfare* (1916), 143.
36. José Dupuis (obituary in *The Times*, 12 June 1965).
37. Pages 277–9, 288–9 provide the only exceptions.
38. Page 466 below.
39. Philippe de Vomécourt, de Guélis, Virginia Hall, Cowburn, Liewer, Lyon, and J. B. Hayes, in charge respectively of VENTRILOQUIST, TILLEUL, SAINT, TINKER, SALESMAN, ACOLYTE, and HELMSMAN. See also Map 3.
40. A distinguished French scholar counts it as one: Hostache, *CNR*, 22.
41. One circuit broken up by the enemy, DIRECTOR, figures in the list above but not on the time chart: see pages 229–30, 329 below.
42. Yet see page 369 below.
43. See his *Skis against the Atom*.
44. In fact, it was discovered at the end of the war that the Germans were far off the right track; but this was not known at the time. Cf. Robert Jungk, *Brighter than a Thousand Suns* (Gollancz and Hart-Davis, trans., 1958), 164–5.

CHAPTER VII

1. Washington file 75526.
2. Memorandum by DMI, 18 July 1940, Appendix C, para. 9; secret.
3. See David Stafford, 'The Detonator Concept', a seminal article in *Journal of Contemporary History*, XVI, 185 (April 1975).
4. [CD] to CEO, 9 September 1940, in an SOE file.
5. Special Operations Executive, 23.
6. 12 November; item 2, most secret.
7. 'Subversive activities in relation to strategy', a paper signed by Pound, Dill and Portal; most secret. CAB 80/56.
8. *History*, XXIII(iv), section D, Paris office, 42. HS7/3.
9. *Ibid.*, 44–5.
10. War diary, 25, HS7/211: reason for failure as obscure as identity of agents.
11. *Ibid.*, and PF.
12. See page 358n.58 below.
13. War diary, 25–6; dated 'at the end of November'. See Merlin Minshall, *Guilt-Edged* (1975). 212–22.
14. Richards, *Secret Flotillas*, 307
15. See page 62; Passy, 85, 89–91, 99–100; Rémy, *The Silent Company*.
16. Buckmaster attended the Dakar fiasco (*Specially Employed*, 12).
17. G. Perrault, *Le secret du jour J*, 244–5.
18. Passy, 81, tr.
19. *History*, XXIII(iv), section D, Paris office, 43. HS7/3.
20. War diary, 101, 28 January 1941. HS7/212.
21. Passy, 136, tr.
22. Passy, 136; war diary, 101, 28 January 1941; HS7/212, Jebb to Portal, most secret and personal, 1 February 1941, in Air Ministry file AHB/1D3/1588.
23. Then Portal's deputy as CAS.
24. Secret and personal, 1 February 1941, in an SOE file.
25. War diary, 204, 15 February 1941, HS7/213; and Barry to War Office, 9 October 1941, for onward passage to the King; in an SOE file.
26. Report by the leader, 5; 9 April 1941, in HS6/345.
27. Near Nevers Bergé slipped across to the unoccupied zone for the day for a formal interview with the father of the girl at de Gaulle's headquarters he proposed to marry; this part of his mission was a success (private information). Bergé later took part in some early SAS raids in the near east; was captured, in uniform; and survived to become a general (Michel, *France libre*, 55). *The Times* printed his obituary on 20 October 1997.
28. HS6/345; Passy, 137, J. E. A., *Geoffrey*, 58–61; Richards, *Secret Flotillas*, 90–1; Barry to War Office, 9 October 1941, in an SOE file; war diary, 101 (28 January), 365 (16 March), 595 (14 April 1941), HS7/212, 214, 215.
29. Bergé's report, 11, in HS6/345; tr.
30. Photograph in Brome, *The Way Back*, at 133.
31. The account of Bitner's task is taken from *History* XXIA, EU/P Section, II, 1–2, and from Chalmers Wright to Foreign Office, 23 September 1966. The *History* wrongly sends him to France in the fifth week of 1941.
32. War diary, January–March 1941, HS7/214–5, *passim*.
33. War diary, 367, 16–17 March, 394, 20 March, and 478, 1 April 1941, HS7/212–15.
34. MS report by him, Lisbon, 19 September 1940 in his PF, not yet released.
35. DF to AD/SI, 7 April 1945, in Rizzo PF; and private information.
36. DF to D/CE P, 2 January 1945, in Planel PF, HS9/1193.
37. For a postwar testimonial intended to set him right with the Belgian government; copy in his PF. See his life by Vincent Brome, *The Way Back*, which opens with an account of the incidents just described.
38. G. Morel, PF, HS9/1059.
39. War diary, 916, 27–28 May 1941, and 1411, 24–25 August 1941, HS7/216, 219; and her PF.
40. Mortimore to Archibald, n January 1945, in Deligant PF.
41. War diary, 649, 22 April 1941; and HS8/1520.
42. See Churchill, *Second World War*, III, 107.
43. CEO to CD, 8 January 1941, SOE file; Cadett had been pressing for power station attacks as early

- as 1 October, before ever he joined SOE (Cadett to Mack in a Foreign Office file).
44. War diary, 577, 11 April 1941, HS7/215.
 45. War diary, 865, 21 May 1941, HS7/216.
 46. There are three survivors' reports on this operation, which contradict each other on this as on several other details. When in doubt I accept the less glamorous account. SOE file.
 47. War diary, 1370, 13–15 August 1941, HS7/219.
 48. Lagier to Piquet-Wicks, 7 October 1941, in an SOE file. SOE paid up
 49. *History XXIVA*, RF section, 1941–43, HS6/123; quoting vanished OVERCLOUD messages.
 50. SOE file, survivors' reports.
 51. *European Resistance Movements*, ii, 49.
 52. Michel, *Histoire de la Résistance*, 30.
 53. See Michael Howard, *The Franco-Prussian War* (1961), 249–56, etc. Howard points out that the Germans besieging Paris in 1870–71 depended on a single railway line for their supplies. But traffic on it was seldom interrupted; for there was no friendly great power to help the French then, as there was in the 1940s.
 54. Conversation with Cammaerts, 4 July 1966.
 55. War diary, 215, 15 February 1941, HS7/213.
 56. War diary, 807, 12 May 1941, HS7/216.
 57. 440, 27 March 1941, HS7/214, dated a day later in Richards, *Secret Flotillas*, 79.
 58. War diary, 394, 20 March 1941, HS7/214.
 59. He had been out on the night of the air raid that hit F section's holding flat; so they called this operation BOMBPROOF.
 60. War diary, 752, HS7/216; and retrospective report by Bégué, 19 November 1942, 1, in his PF, HS9/115. De Vomécourt has him land a hundred miles further south (*Who Lived To See the Day*, 38); Buckmaster has him working a hundred miles north-west, near Le Mans (*They Fought Alone*, 75).
 61. Fourth retrospective report by Bégué, November 1942, 3, in his PF. All further incidents recorded in this narrative are taken from the personal file of the agent chiefly concerned, unless another source is given; or, in a few cases, from wholly reliable private information.
 62. *Who Lived To See the Day*, 25–9.
 63. *Ibid.*, 24. Their father had been killed in action in 1914.
 64. *Ibid.*, 39–40, 71–3, 93–4; citation in PF, HS9/1539/5.
 65. Stradishall ORB, AIR 28/761.
 66. De Vomécourt *Who Lived To See the Day*, 44–8.
 67. Pages 102–3 above.
 68. FOPS was a small group of planners who worked directly under the chiefs of staff, to advise them on the course of future developments in the war.
 69. 138 Squadron formed at Newmarket on 25 August (ORB).
 70. See Piquet-Wicks, 142–53, with portrait.
 71. *Ordre de mission*, drawn up in the Free French war department, 30 September 1941; about a thousand words long (in HS6/834).
 72. *Rapport de Dok sur sa mission en France*, 15 January 1942, *ibid.*
 73. See pages 163–5 below.
 74. Most secret note by Holdsworth that day in an SOE file. Details in Richards, *Secret Flotillas*, 114–16.
 75. E.g., message to OVERCLOUD of 15 December 1941 that his 'last three cables of December 13 had been indecipherable', cited in war diary 2321, HS7/223.
 76. *Four in the Shadows*, 118–23. Piquet-Wicks to Barry, 2 January 1942, forwarded Holdsworth's dated report on the operation: SOE file. And see Richards, *op. cit.*, 117–19.
 77. War diary, 2484, citing DASTARD message of 28 December 1941.
 78. *Four in the Shadows*, 73.
 79. Cf. Hostache, *CNR*, 119–20. But Dewavrin, years later (30 June 1966), denied any enmity towards him.
 80. Note by the gaullist SR, 7 October 1941, in Thomé's PF, HS9/1460.
 81. Cowburn *No Cloak, no Dagger*, 52, suggests – probably rightly – that it was first used in October. Czerniawsky, *The Big Network*, 150, has an intelligence *réseau* using it at about the same time.
 82. Not the Xavier of Millar's *Horned Pigeon*, a much more formidable character, for whom see below, pages 257, 328–9.
 83. *History*, XXIII (iv), section D, Paris office, 40.
 84. *Who Lived To See the Day*, 86; Jumeau's report on his first mission in his PF, 2 (HS9/815/4).

85. War diary, 1267, citing minute of 24 July 1941, HS7/218.
86. His report on return is summarised in war diary, 1490–3, 5–10 September 1941, HS7/220.
87. *Ibid.*, 1300, 31 July 1941, HS7/218.
88. Pronounced Lee-*eh-ver*. Photograph in Minney, *Carve Her Name with Pride*, after 92.
89. She figures prominently, as *Germaine*, in Peter Churchill's *Of Their Own Choice*.
90. The field lay two and a half kilometres SSW of La Champenoise, a village about fifteen kilometres NE of Châteauroux, (Operation instruction No. 1, LEVEE/FAÇADE, 27 August 1941 in Morel PF).
91. War diary, 1520, 5–10 September 1941. HS7/220. This incident is borrowed for the SOE film. So much scent was brought back from France by returning agents that by 1944 FANY'S at the F holding school were using it as lighter fuel (private information).
92. War diary, 1974 and 2076, 12–13 and 21–23 November 1941, HS7/222.
93. Langelaan, *Knights*, 146–8.
94. Morel, interrogation, 21 March 1942.
95. Cowburn interrogation, 30 March 1942.
96. Compare Webster and Frankland, *Strategic Air Offensive*, I, 158–169.
97. Contrast Richards, *Secret Flotillas*, 122, with Cowburn, *No Cloak, No Dagger*. 99. Resistance history is pitted with this sort of minor contradiction.
98. Langelaan interrogation in his PF, undated [1942].
99. Passy, 253.
100. *Leroy* was also Labit's codename; the two characters are of course quite distinct.
101. '*Gonflé à bloc*': FB to F, 15 September 1941, copy in Bodington PF, not yet released.
102. Noguères, *Histoire de la Résistance*, II, 113n, maintains that Roche arrived a month earlier; neither Richards, *Secret Flotillas* nor SOE files bear this out.
103. Not the *Gabriel* who was J. A. R. Starr's wireless operator, for whom see below, pp. 255, 263–4.
104. Operation instruction for Peter Churchill, 1 December 1941, in his PF, HS9/314.
105. 'Mousetrap': one of the commonest words in French Resistance history-writing.
106. *No Cloak, no Dagger*, 58–65.
107. *Ibid.*, 54–5.
108. *Ibid.*, 51–3.
109. Conversation between Gubbins, D/R, Bodington, and de Vomécourt, 7 March 1942, noted in an SOE file.
110. Czerniawski, *The Big Network*, describes what it was; though denying that he was her lover.
111. His story is continued on page 171 below.
112. HS9/993.
113. War diary, 1062, 18 June 1941.
114. Citation, midsummer 1942.
115. War diary, 1090, 23–24 June 1941, citing his operation instruction no. 1.
116. *History*, XXIA, EU/P, section II, appendix A. War diary, 1748, 14–15 October 1941 (HS7/221), reports that 'Much progress has been made with the organization of Polish miners' and farmers, but has no details.
117. E.g., War diary, 972a, 4 June, 987, 6–7 June 1941, HS7/217.
118. War diary, 1524, 11–14 September 1941, HS7/220.
119. *Who lived to see the day*, 33–35.
120. Cf. Michel, *France Libre*, 29. Cf. also Gordon Wright on 'French Resistance' in *Political Science Quarterly*, LXXVII, 339.
121. Noguères' strictures, in *Histoire de la Résistance* ii.127, are beside the point.
122. Twenty-five years later, Cadett recalled that his resignation had been forced because he was too outspoken (BBC broadcast, 28 April 1966). He then joined the BBC.
123. Private information.
124. F section paper of 23 December 1941, cited in war diary, 2437, HS7/224.

CHAPTER VIII

1. Interrogation, 33 October 1941. The attempt left his throat badly scarred and his voice husky. (Piquet-Wicks, 31–2, 55). See also Henri Michel, *Jean Moulin*, 33–3.
2. Moulin, interrogation; and F5 to F, 14 April 1941, in Moulin PF. HS9/1070.

3. Report by Moulin, *ibid.*, tr; undated but presumably October 1941. The whole of this important paper is reproduced at Appendix E, page 437.
4. AD/S to F, 31 October 1941, in Moulin PF: Piquet-Wicks, 41.
5. Conversation with Dewavrin, 29 June 1966.
6. Below, pages 214–15.
7. Moulin PF, tr.
8. D/RF to AD/A, 30 October 1941, most secret; *ibid.*
9. Air transport operation report, most secret, Moulin PF; Piquet-Wicks, 57–9. Up to this time RF section had only managed a single supply drop into the ZNO (Michel, *Moulin*, 93).
10. Michel, *Histoire de la Résistance*, 43.
11. Michel, *Moulin*, 67.
12. Page 61 above.
13. Minute by Dalton on F.T. Davies to Jebb, 18 December 1940, in an SOE file.
14. Paper on 'Raiding Parties' by Davies, 14 December 1940, and minutes of SOE-DCO meeting to consider it, 16 December 1940, *ibid.*
15. Minute by SO, 9 January 1942, *ibid.* The next seven paragraphs are largely based on the short *History*, XIA, Liaison SOE and COHQ; on COHQ archives; on an incomplete set of liaison officers' reports in an SOE file; and on the writer's personal knowledge as an intelligence officer on CCO's staff in 1942–44.
16. SOE to COHQ., 18 June 1942 in an SOE file.
17. *History*, XIA, 5.
18. Pages 26–7 above.
19. Appendix to CCO/SOE liaison officer's report, 1 March 1942, in an SOE file.
20. Private information from a participant in the raid.
21. From the report cited in the last note but one.
22. War diary, 2152, 28–30 November 1941, HS7/222; CCO/SOE liaison officer's report, 10 February 1943, in an SOE file.
23. *History*, XXIVA, RF section 1942, 3, HS7/123. He offered to do as much at St Malo, which was inaccessible to CCO; nothing came of this either, owing to his arrest.
24. Personal knowledge.
25. HS8/793–9
26. See J. E. A[ppleyard] *Geoffrey*, 71–109, for a vivid account, with photographs; and see page 141 above. See also Sweet-Escott, *Baker Street Irregular*, 59.
27. J. E. A., *Geoffrey*, 140.
28. CCO war diary.
29. *Ibid.*, and Winter interrogation, May 1945.
30. Keitel's evidence: *Nuremberg Trial*, XI, 26.
31. *Ibid.*, XV, 301, Jodl's evidence.
32. *Ibid.*, 297.
33. *Ibid.*, 296–306, 403–410.
34. *Ibid.*, III, 213.
35. *Ibid.*, XV, 407.
36. Personal knowledge.
37. 'Notes on the employment of certain Polish subjects in France during the period 1941/1945, for Sabotage and other subversive activities', 5, in a Foreign Office file.
38. Private information.
39. Hazell's July 1955 report, 5.
40. *Ibid.*, 6.
41. D/CE to A/CD, 23 September 1943, Hinton, PF, HS9/714.
42. See Overton Fuller *Double Agent?*, 190, where he is set up as something of an authority on F section, of which he knew almost nothing; and his own *Bid the Soldiers Shoot*, 161–3. He was accidentally killed in 1959.
43. Report by Cowburn, 30 March 1942, in Carré, PF, not yet released.
44. *No Cloak, no Dagger*, 85. See also Richards, *Secret Flotillas*. 122–3.
45. FB to F, 14 February 1942, in G. C. B. Redding, PF, HS9/1230.
46. Not J. E. Redding of SOE's air staff. Both F's newcomers were travel agents by profession; both had been brought up in France; Abbott, born in 1914, was 17 years the younger.
47. M to CD, 1 March 1942, in an SOE file.

48. Note of this interview, 3, sent by M to CD on 10 March 1942. Ibid.
49. M to CD, 18 March 1942, *ibid.*
50. Note of interview with de Vomécourt, 7 March 1942, 1, *ibid.*
51. See *Who lived To See the Day*, 92.
52. Burdeyron interrogation, 26 April 1945.
53. Du Puy report, 30 April 1945, in his PF, HS9/1219.
54. Long after the war, Bleicher and a Russo-German novelist, Count Soltikow, accused de Vomécourt of betraying several colleagues after his own arrest, a charge he hotly and successfully denied in court in western Germany. Nothing in SOE files supports the accusation except one post-war statement of Bleicher's own, in Pierre de Vomécourt, PF.
55. Leon Wolters, PF.
56. Kogon, *Der SS-Staat*, 350; Burney, *Solitary Confinement and Dungeon Democracy*; Burney, PF; page 374 below.
57. Burney, interrogation, May 1945.
58. The principal source for this circuit is Robert Benoist, PF. Its further adventures are in chapter x below, pages 287–8.
59. Not the *Justin* who will appear in chapter x as JUGGLER's wireless operator.
60. *No Cloak, no Dagger*, 107, 115.
61. *Ibid.*, 116.
62. Buckmaster attaches to the preparation of this mission of Rake's in London his anecdote of a note-dirtying fatigue in Baker Street (*They Fought Alone*, 80–2); he commented at the time, on Miss Hall's report of the arrests (30 September 1942, her PF), that the notes must have come from Lisbon.
63. Stella King, *Jacqueline*, is a full and accurate life.
64. *La Libération de Paris*, 42, tr.
65. Guerne interrogation, 14–20 May 1944, 5.
66. Churchill, *Duel of Wits*, 116–17, 124–5, touches on Peulevé's stay on the Riviera; the injured agent arranged his own escape. Buckmaster's account in *They Fought Alone*, 112–24, though exciting, is not borne out by the files.
67. Note by Buckmaster, 18 October 1945, in her PF.
68. Full account in HS 6/567.
69. Report by Bodington, September 1942, 58, in an SOE file. Contrast page 192 below.
70. Report by V. C. Hayes, 13 August 1942 (incomplete), in his PF.
71. Waiting for it, behind a bush on a beach near Perpignan, he recognised waiting behind the next bush an American millionaire, Whitney Straight, whom he had last seen on the dance floor of the 400.
72. His own mother was in charge of the reception committee. Josiane Somers, an RF woman wireless operator who at 19 was the youngest agent SOE put into France, was also received by her own mother; but two years later.
73. *Who Lived To See the Day*, 100.
74. *Ibid.*, 107–110. Some papers he hid under a tree in the park at Bas Soleil, just before he was arrested, and rediscovered in 1951 can now be seen in the Archives Nationales in Paris at 72/AJ/627.
75. *Ibid.*, 122. De Lattre was eventually brought to England by Verity's Hudson.
76. Undated report [late 1942] in his PF, HS9/813/4, 5. Details in Langelaan, *Knights*, 136–60.
77. Among several reports on this escape I have relied on those by Bégulé, Jumeau and Hayes in their PFs and by Lyon (*Calvert*) in an SOE file and on Langelaan, *Knights*, 160–74.
78. *Of Their Own Choice*.
79. *Ibid.*, 90–9.
80. No connexion of the *Bernard* in AUTOGIRO. Photograph (49) in d'Astier *Paris*.
81. Thomas G Cassady to Arthur L. Funk, 12 March 1956. I am grateful to Professor Funk both for this reference and for much stimulating conversation.
82. 'Summary of SOE's report on the French secret army', 2 October 1942, 1; copy in Girard, PF.
83. *Ibid.*, Appendix B.
84. Retrospective report by Basin, 28 April 1944, 4; in his PF.
85. 'Report' of 20 October 1942, 5; in Girard, PF, not yet released.
86. Page 66 above.
87. Copy in HS6/381, 60 pp.
88. F to D/R, 22 September 1942, *ibid.*
89. The meeting also sanctioned the broadcasts mentioned below.

90. HS 6/469, 108. This document, entitled 'British' Circuits in France and running to 136 pages of confidential print, was hurriedly drawn up by Bourne-Paterson in the summer of 1946 as a guide to British consular representatives in France who might be approached by former F section sub-agents.
91. Photograph in Bleicher, *Colonel Henri's Story*, at 128.
92. Details in Garnett, *PWE*, 266–710.
93. Compare Churchill, *Duel of Wits*, 82–4, 105, 183, 216.
94. *Ibid.*, 82, 115–16. Basin was released in November 1942.
95. *Ibid.*, 96–8, 109.
96. Dated 26 August 1942, in his PF, HS9/1096.
97. See Tickell, *Odette*, Ch. XIV.
98. Newman interrogation, 20 November 1942, Churchill, *Duel of Wits*, 126n.
99. Some details in L. Gosse, *René Gosse*, 378–81.
100. She was to have worked for a new circuit round Auxerre, but proved so useful to Churchill that he persuaded Baker Street to let her stay with SPINDLE.
101. Cammaerts final report, 5, in his PF, HS9/258.
102. See Tickell, *Odette*, 177–80.
103. Report by Bodington, September 1942, 29–31, in SOE file.
104. J. A. R. Starr, PF, HS9/1406/8; Overton Fuller, *Starr Affair*, 19–30.
105. Cowburn report, 28 October 1942, in his PF, not yet released.
106. Photograph in Thomas, *No Banners* at 128.
107. Photographs, *Ibid.*, 16–17. See also Churchill, *Duel of Wits*, Ch. I.
108. Newtons interrogation, 26 April 1945, in their PFs, HS9/1096–7. As they were practically inseparable, the British always interrogated them jointly.
109. *Ibid.*, 3.
110. *Ibid.* Contrast page 180 above.
111. Jack Thomas, *No Banners*, gives an honest, sympathetic and vivid account of their war existence.
112. Soustelle, I, 452, n. Aron, *De Gaulle Triumphant*, 22, hints at some degree of German participation in the escape.
113. Passy, 437.
114. *Ibid.*, 438.
115. Leahy, *I was There*, 160.
116. Most secret, to combined chiefs of staff; copy in a Foreign Office file. The Clark-Darlan agreement has been published by Arthur L. Funk in *Journal of Modern History*, XXV, 61–5 (1953).
117. Passy, 440; Soustelle, I, 460; both quoting de Gaulle.
118. Herbert Feis, *Churchill, Roosevelt, Stalin* (1957), 92. For Churchill's intentions, see his *Secret Session Speeches*, 76–96.
119. 20 November 1942, in HS8/901.
120. See Garnett, 261.
121. Private information.
122. Dewavrin, eating his Christmas lunch with Robin Brook, was invited to empty a glass of champagne as a toast to the death of Darlan the traitor (Passy, 447).
123. See Varillon, *Sabordage de la flotte*, *passim*.
124. History, XXIV, F section, 8, HS7/121.
125. She was right to move in a hurry; the incoming head of the Lyons Gestapo said 'he would give anything to put his hands on that Canadian bitch' (A. W. E. Newton report, 11, 3, 26 April 1945, in his PF).
126. Nicholas, *Death Be not Proud*, 120, etc.; and private information.
127. 4 September 1942, in Antelme PF, HS9/42–4.
128. See page 112 above.
129. Memorandum, 10 October 1945, tr unknown. Foreign Office file.
130. See Richards, *Secret Flotillas*, 120–1.
131. Yeo-Thomas to Buckmaster, 23 January 1959; copy in the former's PF, HS9/1458.
132. Details from his PF, HS9/873. Piquet-Wicks, 164–8, has a sympathetic account of the incident. For a similar error, as late as August 1944, see Millar, *Maquis* (2 edn), 226.
133. Michel, *Moulin*, 44, 57.
134. No relation of the Brault alias *Miklos*, who has already appeared.
135. Photograph in Michel, *Moulin*, after 112.
136. *History*, XXIVA, RF section, 1942, 7. HS7/123.

137. Passy, 363; Churchill, *Second World War*, IV, 197–212; Duroselle in *European Résistance Movements*, II, 401–2.
138. *History*, XXIVA, RF section, 1942, appendix A. HS7/123.
139. See Michel, *Moulin*, Ch. IV.
140. Granet and Michel, *Combat*, 91–4.
141. Michel, *Moulin*, 66–7.
142. Robert Aron, *Grands dossiers*, 15–29.
143. Michel, *Moulin*, 73–5.
144. Eden to de Gaulle, 20 January 1942, most secret; copy in an SOE file.
145. M to AD/S, 22 January 1942, *ibid*.
146. *History*, XXIVA, RF section, 1944, 22. HS7/124.
147. Most secret memorandum by Brooke; copy in an SOE file.
148. D/R to M, 9 July 1942, *ibid*.
149. See Passy, 351–2.
150. 1 August 1942; in an SOE file.
151. 8 August, *ibid*.
152. *Ibid*.
153. Details in an SOE file.

CHAPTER IX

1. Memorandum, 10 October 1945, tr unknown, in a Foreign Office file.
2. CAB 80/68, in Stafford (1983), 248–57.
3. Pages 71–2 above.
4. Brooke chairing Pound, Portal, Mountbatten, and Ismay.
5. This defence committee consisted of Churchill chairing Attlee, Eden, Lyttelton, Grigg, Sinclair, Pound, Brooke, Portal, Mountbatten, and Ismay; Selborne, Hambro, Cadogan, Morton, and three secretaries were in attendance.
6. F. E. Morgan, *Overture to Overlord*, does not refer to SOE at all.
7. See Michel, *Courants de pensée*, particularly 445–76, and Hostache, *CNR*, 98, &c.
8. Attlee to Churchill, 23 May 1943, quoted in Avon, *The Eden Memoirs*, ii, 386–7.
9. See the important extracts from his ordre de mission in Hostache, *CNR*, 114–6.
10. Sympathetic sketches *passim* in Passy, and in Piquet-Wicks, with portraits.
11. See Passy, 516–26, *Hippocampe (Seahorse)*. Yeo-Thomas's current codename, was carried over from a project that ATTLA had spoiled; he was to have landed on the Riviera by felucca, in order to cut out from Monte Carlo harbour a fast steam yacht belonging to Molyneux and sail her to Gibraltar (draft project approved by CD, 12 November 1942, in Yeo-Thomas PF, HS9/1458).
12. Close of typescript interim report, 14 March, apparently sent by air in clear; *ibid*.
13. *Ibid*.
14. *Ibid*.
15. Yeo-Thomas noted on return, for RF's eye but not for Dewavrin's, that Delestraint seemed at this meeting to be entirely under the thumb of Moulin, who seldom let him finish a sentence.
16. *Seahorse* report, late April 1943, 6; in Yeo-Thomas PF. Either the communists misled Yeo-Thomas about their lack of arms, or their claims of German dead were much exaggerated.
17. *Ibid*.
18. Michel, *Moulin*, 161–2; Passy, 595–6.
19. Passy, 593–5 and cp Hostache, *CNR 118*.
20. Photograph in Michel, *Moulin*, after 112.
21. A readable account is in Piquet-Wicks, 84–100.
22. Lucie Aubrac interrogation in an SOE file.
23. Klaus Barbie, then head of the Lyons Gestapo, supervised Moulin's arrest and torture. After the war, the French tracked him down in Westphalia, in the American zone of occupied Germany, but could not persuade the Americans to extradite him, as he was currently useful to American counter-Intelligence. (See Richard Aldrich, *The Hidden Hand* (2001), 198–202.) He then fled to South America; was captured by the French, tried, and sentenced to life imprisonment. He died in prison in 1991.
24. Version of Yeo-Thomas's operation order in Marshall, *White Rabbit* 56.

25. Private information.
26. *History*, VIII, agents' ciphers, 6: Marks, *Between Silk and Cyanide*, 382–96.
27. *History*, XXIVA, 1943, 57, HS7/124.
28. Archives Nationales, 72 AJ 421–3
29. As a result, Serreules was coldly received when he found his way back to London next March, and SOE banned his return to France, in spite of impassioned pleas by Emmanuel d'Astier (an eyewitness of the raid). Serreules parachuted back nevertheless; on 16/17 August 1944 too late to have much effect.
30. MARIE-CLAIRE report, early December 1943, 4, in Yeo-Thomas PF.
31. MARIE-CLAIRE diary, ?early December 1943, 4, *ibid*.
32. Contrast page 283 below.
33. Her arrest may not have derived from her connexion with SOE, as she also occasionally worked for one of three large intelligence circuits which were simultaneously under pressure; all three were wiped out. (MARIE-CLAIRE diary, 6; Rémy *Affaire de trahison, passim*.)
34. MARIE-CLAIRE diary, 4.
35. *Ibid.*, 4–5.
36. MARIE-CLAIRE report, 5–6.
37. Interim report by MARIE-CLAIRE, 18 October 1943; sent by air, perhaps in clear copy in Yeo-Thomas PF.
38. Michel, *Moulin*, 95–7.
39. Aron, *De Gaulle before Paris*, 105–6, and see Hostache, *CNR*, 195–61. RF section knew Bidault well, by several SOE field names; but no file on him has been available to me.
40. Hostache, *CNR*, 163.
41. *Ibid.*, 220–35.
42. See Hostache, *CNR*, 187–9.
43. MARIE-CLAIRE diary, 9–10; talk by Yeo-Thomas at Air Ministry news conference, 15 February 1946, 6–7, copy; both in his PF.
44. Livry-Level, *Missions*, 59–65; *History*, IXA, appendix 5 (i).
45. Conversation with Basset, 1969.
46. *Chef départementale de la section Action*.
47. Report by Basset on ARMADA 11, n April 1944, tr, in HS6/349.
48. *Hugh Dormer's Diaries, passim*.
49. Pages 67–71 above.
50. Pages 188–9 above.
51. Passy, 283–4, overestimates it; he was never himself in close touch with it, and knew little of the bodies it left behind when it dissolved.
52. Report by one of his audience who, unknown to him, had been through an SOE school; 25 April 1944, in his PF.
53. Page 184 above.
54. Dramatic accounts of his landing on the Semnoz are in Tickell, *Odette*, 232–5, and his own *Duel of Wits*, 299–313.
55. Rabinovitch interrogation, I October 1943.
56. *Ibid*.
57. De Malval interrogation, 21 November 1944.
58. Group B finishing report, 8 December 1942, in his PF, HS9/258.
59. Compare for instance Millar, *Maquis* (2 edn), 173, or page 217 above.
60. From his final report in his PF, 1.
61. *Ibid.*, 2.
62. His final report, 3.
63. There is an odd conflict of evidence about his Cannes address. Providing part of the evidence for Mrs Sansom's GC, he certified that only she had known of it, and had kept the knowledge to herself under arrest (copy, 20 November 1945, in her PF, HS9/648/4). However, ten months earlier he had indicated that Rabinovitch made the arrangements (Cammaerts interrogation, 16–18 January 1945, 3); and Rabinovitch's own testimony that he had provided the safe house, where some friends of his lived, was positive (Rabinovitch interrogation, 1 October 1943). Rabinovitch forgot to mention that Mrs Sansom knew the house. (Cammaerts to author, 25 May 1966.)
64. Interrogation, 6.
65. *Ibid.*, 4, 9.

66. Ibid., 4–5
67. Ibid., 7.
68. Pages 261, 68.
69. See pages 279–80 below.
70. A striking example of the distance agents' memories can travel is provided by the account given in Overton Fuller *Double Agent?*, 200–1, of his landing on a field edged with Germans who sat in the trees and watched what went on, so that he was trailed to his hotel in Paris where he was arrested almost at once. In a report of October 1944, Raynaud said 'A group of German officers happened to be hunting boar in the nearby wood, about a mile away; they took no interest in us. ... I passed through Paris without difficulty' (tr., in his PF, HS9/1235).
71. See page 330 below.
72. Quoted in F to MT, 24 March 1943, in her PF.
73. Report by Antelme, 25 March 1943, in his PF.
74. Charles Wighton, *Pinstripe Saboteur*, attributes to Weil, whom he does not name, both the code name and the status of JUGGLER's commander.
75. See Guillaume, *L'Abbé Pasty* and *La Sologne*.
76. Report by Antelme, 12 April 1943, 2, in his PF, HS9/42–4.
77. Floege interrogation, 5 April 1944.
78. Ibid.; Bouchardon interrogation, 7 April 1944; Millar, *Maquis* (2 edn), 11–12.
79. Page 288 below.
80. Training report, 10 April 1943, copy in his PF, HS9/554/1.
81. Liewer interrogation, 10–12 February 1944, 4.
82. Ibid., 5.
83. Ibid., 5.
84. FP to F quoting Liewer, 9 February 1944, Liewer PF, HS9/923.
85. See page 359 below.
86. July 1942, from HS9/993.
87. F section had nearly dispensed with his services at the start, because 'his French, though of a high standard, falls just short of the standard of perfection upon which we are obliged to insist' (Gielgud to D/Pers, 30 May 1941; in Trotobas PF, HS9/1487/1); but thought better of it.
88. See page 281 below.
89. See Appendix G below, page 453.
90. The anecdote in Buckmaster, *They fought alone*, 146–8 of the SOE agent disguised as an insurance inspector who photographed the damage a few days later, in fact referred to some other sabotage, further south-east.
91. Yeo-Thomas's MARIE-CLAIRE report, 11, in his PF. It is fair to add that he goes on, 'and the same could be said of most main lines all through France'; this was often due to spontaneous action by the cheminots, unsponsored by SOE.
92. Anonymous report received in microphoto by the February Hudson; tr; in Trotobas PF.
93. Report by Wanborough commandant, 30 June 1942, in Biéler PF, HS9/147.
94. Elizabeth Nicholas in *Death Be not Proud*, 122, described MUSICIAN as a sub-circuit 'under the direction' of PROSPER; this much overstates the extent of Suttill's influence on Biéler.
95. Ibid., 118.
96. *No Cloak, no Dagger*, 166.
97. Ibid.
98. Report by Cowburn, 21 September 1943, 9–10, in his PF.
99. Cowburn, *No Cloak, no Dagger*, 179.
100. E.g., the joint planners' report to the chiefs of staff, 10 June 1943: 'France. Sabotage is widespread and is being mainly directed against, U-boats, blockade running and communication targets.'
101. Page 225.
102. Report by Bardet, ? November 1944, 3, in HS9/88/9.
103. No relation, of course, nor even a compatriot, of Josef Kieffer of the SD.
104. Interrogations of Bleicher's servants, *ibid.*
105. Carré PF, and SOE file cited in last note but two.
106. Report by Meric (*Bibantonin*), 20 November 1944, copy in his PF, HS9/1022.
107. Undated typescript doubts in Carte PF.
108. Page 197 above.
109. Private information.

110. Compare page 115 above.
111. The original of this letter is untraceable; as Admiralty files are unavailable to me, I have not found the original carbon copy either. Bourne-Paterson quotes it in HS 6/469, 38–9.
112. Calmette *L'O.C.M.*, 105.
113. HS 6/469, 37.
114. Calmette *L'O.C.M.*, 102.
115. Calmette *L'O.C.M.*, 169.
116. See page 360 below.
117. 10 July 1944; copy in his PF, tr.
118. Another connexion of Corbin's deserves mention: Labit of RF section had been his godson, and had first recruited him into resistance work.
119. See page 263 below.
120. See page 179 above.
121. In principle, no one who had broken a leg was parachuted.
122. Michel, *Histoire de la Résistance*, 98.
123. Jacques Poirier, *The Giraffe Has a Long Neck*, is informative about Peulevé's circuit as well as his own, which succeeded it.
124. Proust, *Remembrance of Things Past*, I, 62–3.
125. See Churchill, *Second world war*, II, 172.
126. Photograph in Thomas *No Banners*, at 144.
127. Southgate interrogation, 22 October 1943, 3, HS6/579.
128. Memorandum by von Rundstedt, 10 October 1945, trans. unknown, in a Foreign Office file.
129. Thomas, *No Banners*, is mainly borne out by the Newtons' eventual interrogation and reports.
130. Coleman, a lieutenant, RNVR, was F section's only naval officer.
131. For Starr's further adventures see pages 294–6 below. The man who shot him was traced and shot in turn by friends of Rée's.
132. This means of financing circuits was a good deal used; see Appendix C, page 419–20.
133. Air Ministry files.
134. Conversation with him, 1968.
135. Page 87 above.

CHAPTER X

1. P. J. Stead, *Second Bureau*, 75.
2. Jean Overton Fuller has written four books about him; *Double Agent?*, a revision of her *Double Webs*, *Horoscope for a Double Agent*, and *Déricourt: the Chequered Spy*. In all but the last she withheld, at his request, his real name.
3. The source for this is Bodington who knew him before the war (Déricourt PF, 21 July 1944, HS9/421–4 and private information).
4. Long undated MS in his PF, 6, tr, early 1944.
5. Private information.
6. Frager interrogation, 22–26 October 1943; Bleicher, 123. The school's headmistress was Dubois' mother-in-law.
7. Chartrand report, 4 December 1943, in his PF, HS9/299. Chartrand was Liewer's companion, and was also hidden in the school.
8. He suggested to Jean Overton Fuller that 'another organization in London', not F section and by implication not any part of SOE, had authorised him during this visit to 'approach the Germans on [his] return to France' (*Double Agent?*, 137–8). Nothing in the files of any British service bears this out. In fact he had been summoned back to receive a reprimand from his friend Verity, for having endangered a Lysander through an ill-placed flarepath.
9. Wanborough report, 3 February 1943, in her PF, HS9/910.
10. The first syllable of her surname rhymes with how, not low.
11. 161 Squadron ORB. AIR27/1068.
12. 161 Squadron ORB.
13. Of VAR.: see pages 67–71 above. Humphreys sent him to France as *Dyer*, and then destroyed all card index particulars under that code name.

14. Two of the others were Leprince, a giraudist agent, and Francis Nearne, an assistant of Southgate's – brother of Eileen and Jacqueline Nearne.
15. Frager interrogation, 22–26 October 1943, 4, tr. HS6/570.
16. Déricourt second interrogation, 11 February 1944, 2.
17. 161 Squadron ORB.
18. Déricourt, with an interesting economy of truth, told Jean Overton Fuller that these three 'would not have formed a Lysander party' (*Double Agent?*, 176; see also *ibid.*, 42, for the train journey).
19. No connexion, of course, with Ben Cowburn, an earlier user of the same field name.
20. Nicholas, *Death Be not Proud*, 136–49, has many vivid details.
21. *Ibid.*, 147–8.
22. Paper on 'German penetration of SOE', appendix A, 8; top secret, late 1945; copy in *History*, IVB, security, HS8/8320.
23. Contrast Bleicher's suggestion that she was arrested after Clech, to facilitate contact between his agent Bardet and Clech's successor (Nicholas, *Death Be not Proud*, 226–7). Bleicher, *Colonel Henri's Story*, 133, has another version, wrongly dated; and Clech had no successor.
24. Nicholas, *Death Be not Proud*, 125–6.
25. *Ibid.*, 226.
26. Julienne Besnard interrogation, 23–24 January 1945.
27. See Nicholas *Death Be not Proud*, 125, and Overton Fuller, *Double Agent?*, 21–2.
28. To be distinguished from both *Benoits*.
29. Report on KNACKER initialled by Morel 4 February 1944, in Déricourt, PF.
30. *Ibid.*
31. Overton Fuller, *Double Agent?*, 60, says that 'It appeared that more than 240 people had passed from Gilbert's airfields and through Gilbert's hands to England and safety', Zeller, Ely, Mitterrand, Livry-Level, Mme Gouin, and Gerson among them; 'those who could not come in person sent written testimonies'. Livry-Level's own book shows that he was not a passenger but Verity's Hudson navigator. *Libération*, of 8 June 1948, raised the number of passengers to 940.
32. Yet another duplication of names: someone in F section, no doubt unaware of Rivière's existence, looking for a cover name by which the RAF could know Clement (*Marc*), chose Rivière.
33. See table on page 84. The details of Déricourt's and Rivière's operations are from 161 squadron's ORB and *History IX*, appendix 5 (i), HS8/433.
34. Report by Agazarian, 23 June 1943, in his PF, HS9/11/1.
35. Frager interrogation, 22–26 October 1943, tr. HS6/57.
36. *Ibid.*, tr.
37. Bleicher, *Colonel Henri's Story*, 121–3.
38. No trace remains in Air Ministry records.
39. 14 February 1944 in Déricourt PF. The security service, like the French, evidently made no proper distinction between SOE's and more strictly 'intelligence' missions.
40. The arrests that had in fact resulted from CONJUROR, the November Hudson operation, were not yet known in London to have had any connexion with it. The turn of phrase quoted illustrates the writer's habitual caution.
41. A D/P to BSS, 10 February 1944, *ibid.* The security section had taken the same point about casualties months before, foreseeing 'the possibility that a serious disaster may occur in the Field through the agency of this man'; D/CE.G to AD/P, 30 October 1943, copy, *ibid.*
42. FM to F, 19 March 1944, *ibid.*
43. 5 December 1945, *ibid.*
44. Goetz interrogation, 4 November 1946.
45. Interrogation by DST, 22 November 1946, tr.
46. See for instance, *Nuremberg Trial v*, 208–9 or A.-M. Walters, *Moondrop to Gascony*, 114, for revolting tales of young children being tortured under their parents' eyes in unsuccessful efforts to make the parents talk.
47. Interrogation by DST 23 November 1946, 10, tr, in Déricourt's PF.
48. Undated note on D/CE 2 to F, *ibid.*, perhaps written after Bodington's visit to Paris.
49. Culioli report, 28 April 1945, 6; copy in his PF, HS9/379/8. Cp Guillaume, *La Sologne*, 83.
50. Interrogation, 11 February 1944.
51. Rousset interrogation, 11 September 1944.
52. Schäfer interrogation by DST, 16 November 1946, 2, tr, in Déricourt, PF.

53. F/Recs to F, 7 August 1943, quoting Antelme, in Norman, PF, HS9/1110/5. Twenty-five is a more realistic figure than two hundred and fifty; even twenty-five is a lot.
54. See, on the messages, pages 341–3 below.
55. Private information.
56. Placke interrogation by DST, 10 April 1946, 3, tr, in Déricourt, PF. £20,000 was the current sterling equivalent. Goetz replied that was just the price of an estate that Déricourt wanted to buy in the Midi; and the latter admitted to the French that he had been interested in a property worth three-quarters of that sum where he and some friends had proposed to start a chicken-farm (interrogation by DST, 27 November 1946, 14, *ibid.*). £20,000 was also the Germans' price for the four officers they had captured from CONJUROR.
57. Besnard interrogation 14 April 1944, in her PF, HS9/140. Déricourt's file includes a long manuscript report from Clement – part in clear, part in Playfair – explaining his continued immunity from Gestapo attention and expressing every readiness to get on with his work; but this did not get into allied hands till after the liberation of Paris.
58. D'Erainger interrogation, 11 April 1944, in his PF, now destroyed.
59. *Solitary confinement*, 2 edn, ix.
60. Private information, 3 August 1961.
61. Overton Fuller, *Double Agent?*, 204. The idea is elaborated in Wighton, *Pin-stripe saboteur*, 218–21, with no better result.
62. London, 1953.
63. E.g. Kopkow interrogation, 21 January 1947.
64. Buckmaster to Foreign Office, 11 November 1964.
65. Cohen interrogation, 11 October 1943.
66. I owe this simple point to Suttill's son and namesake, properly jealous of his father's memory.
67. For a nearly contemporary chief of staff's view, see pages 71–2 above.
68. Quoted in a long staff report, not earlier than mid-June 1944, on his circuit's troubles; copy in his PF, HS9/1430.
69. Operation instruction of 7 December 1942 in his PF.
70. Agazarian interrogation, 5 July 1943, 4, *ibid.*
71. Report by Agazarian, 23 June 1943, *ibid.*
72. Cf. Brome, *The Way Back*. The double agent who broke into the line was known as Roger, and closely resembled Roger Bardet whose relation to PROSPER will soon appear; but was not the same man. PAT's Roger was reported killed in a maquis skirmish in the summer of 1944.
73. Placke interrogation by DST 10 April 1946, copy in Déricourt, PF.
74. Copy of report by him, 21 October 1943, in Déricourt, PF.
75. Rousset interrogation, 11 September 1944.
76. Kieffer deposition sworn 19 January 1947 in an SOE file.
77. D/CE.G to F, copy, in Déricourt, PF.
78. F to D/CE.G, 3 November 1943, *ibid.*
79. MS in Antelme PF; and Goetz's deposition sworn before Vera Atkins, 21 November 1946, copy in Noor Inayat Khan PF, HS9/836/5.
80. Overton Fuller, *Double Agent?*, 19–20.
81. Culioli report, 28 April 1945, copy in his PF, HS9/379/8.
82. Giskes, *London Calling North Pole*, gives this story from the German side, and Dourlein, *Inside North Pole*, from the viewpoint of one of the captured agents. See also Foot, *SOE in the Low Countries*.
83. American interrogation of Christmann, 24 September 1946, secret, in his PF.
84. Information at second hand from Christmann, August 1961; therefore somewhat suspect. Compare Overton Fuller, *Double Agent?*, 206; there are several accounts of the incident in this book from different persons.
85. Agazarian interrogation, 5 July 1943, in his PF, HS9/11/1. Monique and Delphin were Andrée Borrel and Lejeune.
86. *Prosper* report, 18 April 1943, copy in Agazarian, PF, HS9/11/1; Agazarian report, 23 June 1943, 4–5, *ibid.*
87. De Baissac interrogation, 21–23 August 1943, 5, HS6/567.
88. Guerne interrogation, 20 May 1944, HS9/631.
89. Copy of captured German notes headed 'GRUPPE PROSPER', of uncertain provenance, in an SOE file; and his PF, HS9/1593; and Guerne interrogation, 14–20 May 1944, 9.
90. 'un dur des durs'; 25 June 1945, in his PF.

91. It is just worth disposing in parenthesis of the suggestion in Overton Fuller, *Double Agent?*, 74 n, that the notorious Harold Cole (*Paul*) played some part in the destruction of PROSPER. According to his PF he spent the whole of 1943 in prison; and his work for the Germans never had anything to do with SOE. His specialities lay in escape lines, where he did a good deal of damage. (See Gordon Young *In Trust and Treason* and Foot and Langley, *M19*).
92. Pierre Culioli is the principal hero of Guillaume *La Sologne*, which includes several photographs of him, e.g. after 90.
93. In a citation prepared two years later Buckmaster said 'She defended herself vigorously with her revolver' (June 1945; copy in her PF, HS9/1289/7). This gallant assertion is based on the distant evidence of JUGGLER's wireless operator (Cohen interrogation, 11 October 1943, 3, HS6/568). But Culioli who was beside her when they were caught only mentioned that she fell across him when she was hit; he also said he had hidden his own Colt under a bush early in the journey (Culioli's report of 28 April 1945, 2–4, copy in his PF, HS/379/8; the source also for most of the last paragraph of the text).
94. The importance of the incident of the parcel, correctly divined by the Abbé Guillaume (*La Sologne*, 68–9), is described from the PFs of Culioli and Norman.
95. Its peril was fully appreciated in London; Cohen's report of it produced a storm of apprehensive marginalia (interrogation, 11 October 1943), which could not have been written had London ordered it.
96. Copy in Lejeune, PF, HS9/910/8. This report was carried to England by Verity on 23/24 June.
97. She also is said to have been shadowed, by Gestapo frequenters of the café below her flat (Guillaume, *La Sologne*, 62).
98. The self-evidently absurd claim attributed to JUGGLER's sub-organizer that it was known to himself alone (Wighton, *Pin-stripe Saboteur*, 188) is a howler typical of the errors in many English books on SOE.
99. Renée Guépin to Canon Viossat of Orléans, 17 March 1948; copy in an SOE file.
100. See pages 291–3 below.
101. Deposition sworn before Vera Atkins, 19 January 1947, tr by her; in an SOE file. It is only fair to add that Kieffer went on 'and also through *Denise*' – that is, through Andrée Borrel; the fact that no one else has a word to say against her is some reflexion on Kieffer's reliability.
102. Cited in Mott to Buckmaster, 20 August 1947; *ibid*.
103. Deposition of 21 November 1946, tr in Noor Inayat Khan, PP.
104. Wighton, *Pin-stripe Saboteur*, 187.
105. Rousset interrogation, 11 September 1944, 7.
106. Arend interrogation 15 May 1945, in Andrée Borrel, PF. Compare Nicholas, *Death Be not Proud*, 178.
107. Guillaume, *La Sologne*, 72–8.
108. Guerne interrogation, 1 June 1944, 5–6.
109. Conversation with Cohen, 1968.
110. See Nicholas, *Death Be not Proud*, 220–80, with photograph at 256.
111. See pages 296–7 below.
112. P. Guillaume, *L'abbé Pasty*, 105–115.
113. Rousset interrogation, 11 September 1944, reporting talks with Norman while both were prisoners.
114. Except Vogt's account as reported by Jean Overton Fuller, *Double Agent?*, 47; and Vogt may have wanted to shield someone else. Placke, talking to the abbé Guillaume, hedged.
115. Comment on Guerne interrogation, 14–30 May 1944, para. 186, in Guerne, PF.
116. Private information. On the played-back wireesses see pages 291–308 below.
117. An explanation of what they may have thought they were doing is in Jean Overton Fuller *Double Agent?*, 46–50. It would be more convincing if its author relied less on German sources.
118. There is a slight indication in the files – in the shape of a note from Bodington direct to D/R about medals policy, on 29 June – that Buckmaster may have been away on leave in the critical week.
119. H. G. R. Newton report, IIB, 3, 26 April 1945, in his brother's PF.
120. Note by an SOE security officer, 4 April 1945, of interview with Bodington on previous day, 3; in Déricourt, PF.
121. *Ibid*.
122. Rousset interrogation, 11 September 1944, 2, in his PF, HS9/1286; citing conversation with Dowlen while both were prisoners.
123. Statement by Paul Schroeter, 5 July 1946, copy in Grover-Williams, PF, HS9/1596/8.

124. Report by Maurice Benoist, January 1945; copy in Robert Benoist, PF, HS9/127–8. Compare page 292 above.
125. R. Benoist interrogation, 4 September 1943, HS6/567.
126. Cf. pages 202, 205–6, 217–18 above.
127. Gerson interrogation, 20 December 1943, 4.
128. Christmann interrogation by DST, 17 May 1946, 30. This makes it the more ironical that two of them ‘got a very stiff-security lecture’ from Gerson for leaving the safe house in Lyons and getting drunk, (Gerson interrogation, 20 December 1943, 1.)
129. *Ibid.*, 2
130. *Ibid.*, 3–4.
131. Pages 245–6 above.
132. Readers may care to refer back to the account on pages 99–101 of the stages clandestine messages had to pass through between the field and Baker Street.
133. HS 6/469, ‘*British*’ *Circuits in France*, 9.
134. Southgate report. May 1945, 9; compare Overton Fuller, *The Starr Affair*, 57–8.
135. Sworn statement by Goetz 21 November 1946, confidential; copy in Noor Inayat Khan PF.
136. Undated report by Southgate, about 8 May 1945, top secret; copy in his PF, HS9/1395. Buckmaster commented: ‘The attached is clearly the report of an extremely tired man.’ (F to AD/E, 9 May 1945, *ibid.*)
137. Interrogation, 23 July 1943, in Antelme PF.
138. F/Recs to F, 5 August 1945, in Norman, PF.
139. F’s comment on note from F Recs, 7 August 1943, *ibid.*
140. Report by Warden on visit to Fresnes, 27 January 1945, 1; Vogt interrogation, 19 June 1948 – copies of both in J. A. R. Starr, PF; and report by Culioli, 28 April 1945, copy in his PF.
141. Goetz interrogation, 3 September 1946, in Noor Inayat Khan, PF.
142. *They fought alone*, 75.
143. Note by Buckmaster, 28 December 1945, in Pickersgill, PF, HS9/1186/2.
144. Private information.
145. Wheels within wheels: the stores used in the attempt on Hitler on 20 July 1944 included British plastic and fuses, which may originally have been dropped for AUTOGIRO (Wheeler-Bennett, *Nemesis of Power*, 589 n). They reached the conspirators, from an Abwehr source in France, in September 1943.
146. Overton Fuller, *Double Agent?*, 69–73, quoting Placke interrogation by DST; but compare page 325 below.
147. Like almost every other Paris address in this chapter, this is in the 16e arrondissement; it lies midway between the Arc de Triomphe and the Trocadero, off the Avenue d’Iéna.
148. An SOE file on PRIEST includes a decoded copy of this correspondence and a couple of crumpled pages of the original. HS9/412/2
149. Secret report, 17 April 1944, and Guillot report, 12 April 1945, in an SOE file.
150. Pickersgill, PF; Guillot report, 12 April 1945, in the same SOE file.
151. Overton Fuller, *The Starr Affair*, 91–3; private information. Starr interrogation, 28–30 May 1945, 6–7, in his PF, glossed over the story.
152. *Ibid.*, 2–5; page 256 above.
153. *Ibid.*, 5.
154. J. A. R. Starr interrogation, 28–30 May 1945, 5.
155. Interrogation of Goetz by Major Terry, 26 July 1946, 2: in V.M. Atkins PF, HS9/59/2.
156. *Ibid.*, 5–8.
157. Details, *ibid.*, 8–9, and in Overton Fuller, *The Starr Affair*, 68–84.
158. J. A. R. Starr interrogation, 28–30 May 1945.
159. Details in his PF.
160. Interrogation by DST, 1 April 1946, tr, *ibid.*
161. Interrogation by DST, 17 December 1946, tr, *ibid.*
162. Interrogation by DST, 6 January 1948, copy, *ibid.*
163. [30 May 1945], *ibid.*
164. Rousset interrogation, in September 1944.
165. J. A. R. Starr interrogation, 28–30 May 1945, 11. Rousset interrogation, 11 September 1944, does not mention the reaction. The messages are no longer available.
166. E. A. H. Garry, PF, HS9/566/2.
167. Overton Fuller, *Madeleine*, 85, 94.

168. Noor was her forename, Inayat her surname; Khan (cf. the English 'Lady') indicated her high birth. Her training reports are unanimous about her physical clumsiness, as about her charm.
169. *Madeleine*, her life by Jean Overton Fuller; her PF; and private information.
170. Overton Fuller, *Double Agent?*, 25.
171. Private information.
172. 21 May 1943.
173. *Ibid.*
174. Overton Fuller, *Madeleine*, 89, 93, 120.
175. *Ibid.*, 114. But the tales in *Madeleine* of her transmission times do not fit well with the NURSE plan she was given in London; her regular schedules were at 9.5 a.m. on Sundays, 2.10 p.m. on Wednesdays and 5.10 p.m. on Fridays, though she could use either of two emergency frequencies at any hour of any day if no one else was working it at the time. This last facility was later withdrawn; an agent complained of the lack of it in the hectic days of summer 1944 (Hiller report, a January 1945, 15, in his PF, HS9/710).
176. 9 June 1943, in her PF.
177. In Robert Benoist's PF.
178. Antelme report, 12 August 1943, in his PF, 4.
179. Overton Fuller, *Double Agent?*, 13–14.
180. Overton Fuller, *Madeleine*, 144–7, 154–5, has plenty of dramatic details about both arrests; passages in quotation marks render their authenticity doubtful.
181. *Ibid.*, 127.
182. In paragraph 2 of the 'method' heading, 9 June 1943, in her PF.
183. 7 December 1942 in his PF.
184. See page 451.
185. Report of interview, 5 June 1943, in her PF.
186. Sworn statement by W. E. Rühl, 20 November 1946, in her PF.
187. These, of course, could be inferred from her captured exercise book.
188. Deposition sworn by Kieffer before Vera Atkins, 19 January 1947, in Noor Inayat PF; tr.
189. Marks, *Between Silk and Cyanide*, 320–1; conversation with him, 1998.
190. Goetz interrogation, 3 September 1946, in her PF, tr. Vera Atkins.
191. *Ibid.*
192. *Ibid.*
193. Dourlein, *Inside North Pole*, 98ff, gives a telling account of what this felt like.
194. Mille Damerment's ordre de mission gives the dropping zone as 3 kms SE of Sainville 31 kms ESE of Chartres (22 February 1944 in her PF).
195. 4 February 1944, in his PF.
196. Paper on 'German penetration of SOE', December 1945, 13; top secret; copy in *History*, IVB, security.
197. See Giskes and Dourlein, *passim*.
198. Antelme to Morel, 23 January 1944, in Antelme's PF.
199. 4 February 1944, paragraph 2b, in his PF.
200. *Ibid.*, and P. F. Duclos, PF, HS9/453/7.
201. Minutes exchanged between F, D/R, and DYC/M [Marks], 13–15 April 1944, in Lee PF, HS9/905.
202. Morel and Bourne-Patterson to Buckmaster, 17 April 1944, *ibid.*
203. Pencil minutes on D/R to AD/P (copies to AD/E and F), 17 April 1944, on an SOE file.
204. Kopkow interrogation, 12 January 1947, and an SOE file.
205. Kopkow again.
206. SOE file quoted in last note but one.
207. P. F. Duclos, PF.
208. C. Hibbert, *The Battle of Arnhem* (London, 1962), 209.

CHAPTER XI

1. Outline and consequent directive summarised in *History*; XI, SFHQ, 21–5.
2. *Ibid.*, 22.
3. Michel, *Courants de pensée*, 233.

4. Item 14 – far down the list; *History*, IXE, 79–81.
5. D’Astier, *Les dieux et les hommes*, 20–1, tr. (the bracketed English is his own).
6. The chance was offered through a very old friend of Churchill’s, General Swinton the inventor of the tank (Marshall, *The White Rabbit*, 86–9).
7. Tr. in *Les dieux et les hommes*, 76–83; first page reproduced in facsimile, *ibid.*, 179, with the ‘most secret’ grading but without the reference number.
8. They had begun already: the first CARPETBAGGER sortie was on 4/5 January (Craven and Cate, *Army Air Forces*, III, 499). The ‘two fresh squadrons of British bombers’ allocated to SOE in March, according to Ehrman (*Grand Strategy*, V, 326), were in the Mediterranean, working principally into Yugoslavia; though they made occasional drops into France (148 and 624 Squadron ORBs, AIR27/994 and 2142).
9. *Dieux et hommes*, 81 n, tr.
10. Memorandum by Dansey, 8 February 1944, copy in Foreign Office file. Dewavrin noted long afterwards that, while he could not dispute the views attributed to him, he was in Algiers till the end of February 1944 (conversation with author, 21 June 1966).
11. *History*, IX E, 91–3; and see page 422 below.
12. RAF Bomber and Transport Command ORBs alike ignore this operation; Fighter Command had not the capacity, nor Coastal Command the training, so it must have been an American drop.
13. For some detailed figures see Ehrman, *Grand Strategy*, v, 326, quoting an SOE source which he had to disguise – in 1956 he was not allowed to refer to specific country sections of SOE, so he called RF’s supplies ‘*From General de Gaulle*’ and F’s ‘*From S.O.E.*’. More details are in Appendix C, page 419 below. Supplies put into Yugoslavia were rather larger: see Maclean, *Eastern Approaches*, 461 n.
14. From an SOE file.
15. Personal knowledge.
16. Memorandum, 10 October 1945, tr. unknown. Foreign Office file. It needs to be remembered that von Rundstedt wrote this paper to assist in his own defence in a war crimes trial; he had no interest, when he wrote it, in under-estimating the strength or the achievements of resistance.
17. Interrogation, 9 May 1944, 6.
18. Marshall, *White Rabbit*, 65.
19. *History*, XXIVA, 1944, 4.
20. P. J. Stead, *Second Bureau*, 73, 78, 89; Hostache, 29; Passy, 204–7, 365–7. Michel calls him ‘the first agent to enter the southern zone, at the end of 1940’ (*Jean Moulin*, 43, tr.).
21. *History*, XXIVA, RF section, 1944, 8, HS6/124.
22. Undated ordre de mission in HS6/359.
23. *History*, XXIVA, 1944, 8, HS6/124.
24. Thackthwaite report, 11 May 1944 (last quoted sentence tr.); copy in HS6/359.
25. Cammaerts report, 16 April 1944, received by Lysander 30 April; in his PF, HS9/258.
26. Cp Maclean, *Eastern Approaches*, 332, 425, &c.
27. It is a little odd that during the war nobody, English, French, American, or German seems to have taken the trouble to look into what the lessons of guerilla in the peninsula had been, although Dalton referred to them before ever SOE was founded (page 9 above). Cf. Michel, *Courants de pensée*, 67–8.
28. Churchill, *Second World War*, V, 163, refers to ‘unnecessary incidents’ between gaullists and giraudists. Piquet-Wicks recounts Scamaroni’s Corsican adventures and death (124–41, with photograph at 96).
29. *Intelligence and National Security*, xv.19 (2000).
30. Churchill, *Second World War*, V, 620.
31. *Memoires*, 518–19, lv.
32. *St Jacques*; see Passy, *passim*. No connexion of course with his communist namesake.
33. *History*, XXIVA, 1944, 24, HS6/124.
34. Another fruitful source of confusion: the CFLN at Algiers also had an action sub-committee, usually known as COMIDAC but sometimes called COMAC also. Needless to say the two were totally distinct; COMAC was inside France, COMIDAC was outside.
35. On whom see Hostache, *CNR*, 163–4; photograph (39) in d’Astier *Paris*.
36. E.g. Hostache, *CNR*, 132–3.
37. See pages 215–16 above.
38. Aron, *De Gaulle before Paris*, 226–7, corrected from P. M. Williams, *Politics in Post-war France* (1954), 455, 457. Photograph in Collins and Lapierre *Is Paris Burning?* after 128. No files on any DMN or DMZ have been available to me; nor does anything appear to remain on record, in London, about how or why SOE came to change its mind and agree to their appointment. (In any case, SOE’s

- files get thinner at the highest levels as the war goes on.) Some of de Gaulle's objects in appointing a DMN are given in his *Mémoires*, 517.
39. Undated post-war note by Thackthwaite in *History*, XXIVA, RF section.
 40. List in Appendix B, page 418.
 41. Cf. Soustelle, II, 308–9, on the DMRs as the real animators of internal resistance, an interesting if controversial view.
 42. *Cahiers de l'Iroise*, October–December 1961, 203–6.
 43. Operational instructions, 15 February 1944, in his PF; version in Marshall, *White Rabbit*, 101.
 44. Overton Fuller, *Double Agent?*, 50–1; Hostache, *CNR*, 189 n.
 45. Photograph (64) in d'Astier *Paris*.
 46. Aron, *De Gaulle before Paris*, 124; Hostache, *CNR*, 193; short SOE file on CLE, HS6/364. Operation instructions, signed by de Gaulle, reproduced in d'Astier *Paris* at 314–15; report on return quoted *ibid.*, 322–4.
 47. SOE code names for operations tended to fall into groups. F's were usually named after trees at first, then after occupations. RF used fish; AL used weapons. In 1943 RF also took to names of occupations, in French, for organizers; and to names of tribesmen for wireless operators. CITRONELLE was an early example of a new series – herbs and scents for interallied missions.
 48. HS6/358.
 49. TUTOR, F's contribution to this brutish operation, was, if not nasty, poor and short. A Pole named Feingold was parachuted, late – on 10 March – to kill the head of the Marseilles Gestapo or his assistant; could not find either; found his safe houses unavailable; and after only three days in France fed himself onto a DF line across the Pyrenees. The same codename, RATWEEK, was applied to a major attack on German communications in Yugoslavia later in the year (Maclean, *Eastern Approaches*, 470–97).
 50. This phrase is not meant to imply that DF's escape agents were non-operational, only to distinguish from them people who were sent on tasks which were more active, if no more dangerous.
 51. See Madelaine Duke, *No Passport*, an illustrated life of him.
 52. Pages 67–71 above.
 53. Pages 277–9 above.
 54. Chalmers Wright, PF, HS9/1622.
 55. He had been an instructor at the Staff College, Camberley, and was later deputy chief of the defence staff.
 56. 17 by air and Defendini by sea. *Dispenser* had also fallen victim to the ARCHDEACON game, many months before.
 57. Many details in Nicholas, *Death Be not Proud*, 104–21, etc.; though no reference is made there to Berthe Fraser's arrest nearby in mid-February. Mme Fraser survived six months in solitary confinement at Loos, under frequent and painful interrogation, without revealing anything. Her health was never restored, though she did not die till 1956.
 58. Undated final report by Dumont-Guillemet, 2; copy in his PF.
 59. *Ibid.*, tr., cf. Foot, *Men in Uniform*, 56, 69.
 60. Report by Dumont-Guillemet, 19 July 1944, transmitted through Spain; copy in his PF.
 61. Churchill, *Second World War*, VI, 40.
 62. Note by Buckmaster, 7 December 1945, in his PF, HS9/599.
 63. Statement by Baudot at Oxford conference, 1962.
 64. Photograph in *Sunday Express*, 19 January 1947.
 65. Knight interrogation, 5 January [1945].
 66. Millar *Maquis* (2 edn), 55–6.
 67. *Ibid.*, Chapters III–V.
 68. It was not known in SOE that her real name and her role on her first mission had been communicated to the Germans late in 1943 in the course of a wireless game played by another British secret service.
 69. Geoffrey Parker, *Black Scalpel*.
 70. At about this time George Millar, escaping from a German prison camp, crossed MARKSMAN's area; Heslop is the legendary *Xavier* of Millar's *Horned Pigeon*.
 71. No connexion of Gerry Morel.
 72. Reynaud, *Thick of the fight*, 604–5.
 73. *History*, XXIVA, RF section, 1944, 19, HS6/124.
 74. Private information from a family friend of his.
 75. To be distinguished, of course, from Odette Sansom (*Lise*).
 76. *Death be not proud*, 246–67.

77. *Ibid.*, 264–5.
78. *History*, XXIV, F section, appendix. HS6/121.
79. G. J. Parke, interrogation, 16–18 November 1944, 20.
80. Despaigne to author, 6 June 1966.
81. There surely is a field for the local resistance historian: how far did areas of maquisard and camisard strength overlap?
82. *Who Lived to See the Day*, 132–148. The Eysses escape was only in small part a success story. D’Astier records the dispatch of 3,500 other prisoners to Dachau; 130 survived (*Paris*, 144).
83. See her *Moondrop to Gascony*, 65–82.
84. See Appendix G, page 453.
85. See Bergeret and Grégoire, *Messages personnels*, for a vivid picture of de Gunzbourg’s area at the time.
86. I Samuel, XXII, 1–2.
87. Most DMRs were named after French geometrical terms: *Ellipse*, *Circonférence*, *Ligne*, and so on. The converse was not always true; Fourcaud of UNION was *Sphère*, for example, and Bolladière of CITRONELLE was *Prisme*.
88. Pages 114–15, 350, 375.
89. It was imprudent to send Beauclerk and Sereni to the field at about the same time with the same field name: a sign perhaps of bad tabulation between London and Algiers.
90. See Appendix G, page 453.
91. Boiteux’ GARDENER was to look after the VENI groups in Marseilles as Hiller looked after the more numerous ones in the Lot.
92. Hostache, 60.
93. *Ibid.*, 152–3.
94. A third brother, J. A., was caught working with ROVER in May, and later executed in Germany.
95. Giskes, *London Calling North Pole*, *passim*.
96. According to a statement by Buckmaster more than twenty years later. This is all the more creditable to the self-imposed isolation in which SOE’s staff lived, in the light of the juxtaposition of F’s and D/R’s officers, who shared the same floor in Norgeby House.
97. Buckmaster recounts the tale that Vera Atkins arranged for Cornioley to be on his fiancée’s reception committee. So she did; but stress of weather sent Miss Witherington to another ground in the next county.
98. Mockers, *Maquis SS4*, 16.
99. Buckmaster, his warm admirer, has left several eulogies on his PF. Compare page 44 above.
100. Southgate report, 16 April 1944, in his PF: Mme de Strugo to author, 21 September 1966.
101. See telegram on page 100.
102. See the new life of her by Susan Ottaway.
103. His operation instruction for this mission is given at Appendix F, page 447. It may be taken as typical of the sort of orders F’s agents were given; the layout horrible to a trained staff officer, yet marked by undeniable fighting enthusiasm. A typical set of wireless operators’ non-technical orders, for Marcel Clech’s second mission, is included in the same appendix.
104. Page 302 above.
105. Buckmaster indeed recorded the five Breton departments as a ‘Free French’ area in what purported to be a map of his circuits: *They Fought Alone*, 75.
106. *Who lived to see the day*, 167–201.
107. *Ibid.*, 202–10; her photograph at 129.
108. Foreign Office and SOE files.

CHAPTER XII

1. *Who Lived to See the Day*, 317.
2. See pages 32–3 above.
3. VERVEINE mission report HS 6/572; *History*, XXIVA, 1944, 29, HS6/124.
4. A number of senior French staff officers were summoned to a meeting in Baker Street earlier that evening; Brook had meant to tell them of D-day, but as the invasion was postponed a day he held an informal cocktail party instead. (Private information.)

5. *Second World War*, II, 550. See also Simon Berthon, *Allies at War*, 304–13.
6. *De Gaulle before Paris*, 10–7.
7. Two men from TITANIC found their way into the beachhead by 20 June; a feat, for they travelled as they had jumped, in uniform. The rest were taken prisoner; one escaped (SAS Bde war diary, June).
8. Ellis, *Victory in the West*, I, 200.
9. Conversations with Dewavrin, June 1966, and Brook, January 1967.
10. D/R to MS/C, 30 May 1944; and D/R to AD/E, 4 June 1944, both in *History*, XXIVG, BBC messages.
11. Pencil note, *ibid.*
12. See pages 296–7 above.
13. Compare pages 270–1 above. Goetz once boasted to me that he knew fifteen of the D-day action messages.
14. *Victory in the West*, I, 198.
15. Page 293 above. The population balance of Alsace had of course shifted since 1940, under the impact of German-speaking immigrants from south Tirol.
16. E.g., summary in Paul Leverkuehn, *German Military Intelligence*, 50–2.
17. *Les dieux et les hommes*, 116, 126–7, 187–8.
18. See Morris Janowitz, *The Professional Soldier* (Glencoe, Ill. 1960), 232–56.
19. See pages 76–8 above and Appendix C below, page 419.
20. Undated, in HS6/423.
21. Photograph in Tanant *Vercors* at 80; pronounce Long.
22. See, for instance, Simone de Beauvoir *The Mandarins*, chapter V; Tillon *FTP*, Chapter XV.
23. Photograph in Tanant at 64.
24. Private information from one who had handled the document.
25. *History*, XIII, AFHQ., chapter vii, annex H, 3. HS7/170. This ambush had taken place on 7 July; it so impressed the Germans that they believed the OG was of battalion strength (*ibid.*, 6).
26. Pecquet's activity report, 19; the best surviving account by an SOE participant, in HS9/1160/1. The most authentic printed account is *Vercors* by Pierre Tanant, Huet's chief of staff; its pages 148–181 cover 'le martyre'.
27. Pecquet report, end.
28. In HS6/424.
29. Green to Dismore, 12 October 1944, in HS6/359.
30. Report by Ortiz, 12 May 1945, 4. copy, *ibid.*
31. From HS 6/365.
32. In a paper circulated privately in 1940.
33. Tillon *FTP* provides an incomplete and in places a prevaricating defence. See page 370 below.
34. SHAEF estimate of moves of German armour, prepared by J. L. Austin in May; quoted from SAS Bde war diary.
35. Aron; *De Gaulle before Paris*, 208.
36. HS4/227, 229.
37. E.g., Tillon *FTP*, 256–7.
38. *History*, XXIVD, JEDBURGH. See Map 4.
39. Page 76.
40. All JEDBURGHs were named after English first names or after drugs.
41. Private information: the incident is not forgotten on the spot.
42. See also map 4.
43. Farran, *Winged Dagger*, Harrison, *These men are dangerous*, McLuskey, *Parachute Padre*.
44. Report by C. K. Benda, 7 September 1944, in HS8/378.
45. Personal knowledge.
46. SAS Brigade war diary, June–August 1944, *passim*.
47. Twelve Mosquitos secured the best petrol fire they had known, at Châtellerault on BULBASKET'S intelligence (personal knowledge). And see Paul McCue, *SAS Operation Bulbasket*.
48. The Mosquito squadron that had benefited from BULBASKET is said to have pursued the SS battalion till its remnant was disbanded. And see page 85 above.
49. It is ridiculous to call SAS troops agents; but newspapers occasionally do so. Both these units were later incorporated in the French army as the first two RCP.
50. Lengthy account in Aron, *De Gaulle before Paris*, 10–7.
51. His identity is given in R. Leroux, 'Le combat de Saint-Marcel', in *Revue d'histoire de la deuxième guerre mondiale*, July 1964, 13–14; not his connexion with SOE.
52. SAS Brigade operation instruction, 9, 21 May 1944, in brigade war diary.

53. SAS Bde war diary, 10 June 1944.
54. R. Leroux, 'Le combat de Saint-Marcel', 15.
55. SAS Bde war diary, 26 June. A useful result of forcing the enemy off rail transport was the consequent further drain on his petrol.
56. *Ibid.*, 15 June 1944.
57. *Ibid.*, 18 June 1944; personal knowledge; private information. And see R. Leroux, *Le combat de Saint-Marcel*, 22, 25–7.
58. Eon and four of his companions made their first parachute descents that night (HS6/363). One more, prostrated by air-sickness, refused. Report at Vincennes, SHAT 13 p.35.
59. Report by McLeod 18 August 1944, in SAS Brigade war diary.
60. *Report by the Supreme Commander to the Combined Chiefs of staff on the Operations in Europe of the Allied Expeditionary Force* (HMSO 1946), 52–3. Tillon uses this passage, omitting the reference to SAS and thus transforming the sense (FTP, 375 n).
61. Rémy, its inventor, *Les mains jointes*, 127–30.
62. From a technical survey of German military rail operations in France prepared late in 1944 for the general who had commanded them; Washington file 1027.
63. *Moondrop to Gascony*, 277–8.
64. Arthur L. Funk, *Hidden Ally*, provides a fresh insight into the effectiveness of resistance co-operation with regular forces.
65. André Malraux, 26 January 1945, at an MLN Congress. He claimed as the other *acquit décisif* 'the general organization of a plan which made military action possible' on French soil. (Foreign Office file, tr.)
66. De Vomécourt, *Who lived to see the day*, 18–19, 263–73, exhibits intelligibly strong feelings about this. SHAT 13 P62 contains General Elster's surrender document signed in Issoudun on 10 September.
67. Dansette, *Libération de Paris*, 130.
68. Wheeler-Bennett, *Nemesis of Power*, 662–74; Peter Hoffman, *History of German Resistance* (1977 edn, tr. R H Barry), 470–8.
69. Dansette, *Libération de Paris*, 159.
70. *Ibid.*, 469–71. According to Collins and Lapierre (*Is Paris Burning?*, 100, 108), the gaullists in Paris stole a march on the communists over that night, by a trick which secured them the possession next morning of the prefecture of police, the focal point of the rising. The communist police invited to join in seizing it did not get the message in time, as the security hedge they had placed round themselves took too long to penetrate.
71. Dansette, 472.
72. *Ibid.*, 320–4. Ziegler told Collins and Lapierre (*Is Paris Burning?*, 214, 349) that he had initiated this *canard*, to shame SHAEF into making it true.
73. Langelaan, one of F's early adventurers, entered Paris in British uniform late that evening, in a political warfare team (*Knights*, 307–20). Ernest Hemingway came with another, liberated the Ritz, and cleared the snipers off Sylvia Beach's roof (*Guardian*, 26 August 1964, 7).
74. *Leclerc's* American superior tried to prevent his tanks from taking part in this demonstration: Dansette, 401–4.
75. There is said to have been keen debate at EMFFI about whether the general should ride a white horse, a Bonapartist symbol, or a black, like General Boulanger.
76. Dansette, 410–12, tr.
77. *Mémoires*, 573.
78. *De Gaulle triumphant*, 281–5, 346.
79. F. S. V. Donnison, *Civil Affairs and Military Government: North-West Europe, 1944–1946* (1961), Chapters III–VI and Appendix II; Hostache, *CNR*, Chapters VII–X. See also the agreeable anecdote in Robert Aron *Histoire de la Libération*, 81, of de Gaulle's cry of 'Recognition' when two gendarmes met by chance in Normandy in the second week of June were polite enough to do something he asked them to do.
80. Some old friends of SOE's had a hand in this: Racheline for example, dispatched to France in July by parachute for this specific purpose, installed himself, early in the fighting, in the minister's room in the ministry of the interior, Place Beauvau, and held it in the gaullist interest for a week. For Yvon Morandart's adventure see d'Astier, *Paris*, 201.
81. See Curzio Malaparte *La technique de coup d'état* (1931), 30.

CHAPTER XIII

1. HS 6/432. Several more stanzas of this leg-pull are in Ewan Butler, *Amateur Agent*, 230–1.
2. Déricourt went on flying for many years. He was reported killed in an aircraft accident in Laos on 20 November 1962.
3. A. J. Ayer, the philosopher, a GSO III in RF section. The title of an FO file, no longer available – stating a fact, of course, not a policy – should not be lost to history: ‘No job for Freddie Ayer’.
4. *History*, XXIVK, 95.
5. *Ibid.*, 96.
6. See Gordon Wright in *Political Science Quarterly*, XXVII, 336 (1962).
7. This figure is given by Baudot in *European Resistance Movements*, II, 391–2. He adds that 60,000 of them had joined by mid-October, and 15,000 more by the end of November; in time to relieve all the African troops in de Lattre’s army before winter set in.
8. Leproux, *Nous, les terroristes*, II, 318.
9. ‘He fought throughout the Spanish War in a Spanish regiment, not in the International Brigade, as he is not a Communist’ (DF to BSS/ D, 24 October 1944, in Jeschke, PF, HS9/712); Madelaine Duke, *No Passport*, 216–7.
10. *History*, XXIVH, HS7/134.
11. E.g., Nicholas, *Death be not proud*, 113, 119–21.
12. J. W. Wheeler-Bennett, *Nemesis of Power* (1953), 662.
13. Michel, *Histoire de la résistance*, 124.
14. Donnison, 220, quoting an VIII Corps report of April 1945; compare Russell of Liverpool, *Trial of Adolf Eichimnn* (1962), 137.
15. See Foot, *SOE in the Low Countries*, 197.
16. Hans Lunding, interrogation, 12 May 1945, 2; Vera Atkins to I. MacKenzie, 5 July 1945.
17. Reid, *The Colditz Story* (1952), sketches the troubles.
18. Cf. Jack Thomas, *No Banners*, 284–309.
19. Including Allard, Robert Benoist, Defendini, Detal, Garel, Garry, Geelen, Hubble, Leccia, Mayer, Macalister, Pickersgill, Sabourin, and Arthur Steele.
20. That two groups were executed is certain, but there are several contradictory versions of the details of names and dates. The account above rests mainly on a report by Balachowsky of 23 April 1945 (in Yeo-Thomas P F) and on Vera Atkins’s later investigations (in an SOE file).
21. See pages 193, 337, 416.
22. Webb, *The Natzweiler Trial*, has all the details.
23. Ott interrogation, 27 May 1946; he accompanied them on their journey from Karlsruhe.
24. Kogon, *Der SS-Staat*, is the most authoritative account from inside.
25. Wynne, *No Drums, no Trumpets*, 264–6.
26. Contrast with page 239.
27. See page 356.
28. Minney, *Carve Her Name with Pride*, 155–62.
29. Atkins to Mott, 23 July 1946, in an SOE file.

CHAPTER XIV

1. Nothing has ever been published about this officially; though three distinguished novelists, Compton Mackenzie, A. E. W. Mason, and Somerset Maugham, have produced accounts apparently based on their experiences as secret service agents, and there are several unofficial versions of the achievements of Admiral Hall’s cryptographers. Recently, an author has been given privileged access to the papers.
2. Compare Churchill, *Second World War*, II, 141, recording how two German fighter pilots missed their chance to win the war for Germany in June 1940.
3. See J. W. Wheeler-Bennett, *The Nemesis of Power*, part III, chapters 5, 6, 7; and Hoffmann, *German Resistance*, 290–503.
4. See Fitzroy Maclean, *Eastern Approaches*, 195, where Mayne’s total score is more than doubled. Mayne survived a dangerous war to die of a heart attack in his native Ulster (obituary in *The Times*, 15, 24 December 1955, and private information).

5. Webster and Frankland, III, 88; compare *ibid.*, I, 464–72.
6. This figure is compiled from the detailed damage assessments made just after the war on which Appendix G is based.
7. Webster and Frankland, III, 202.
8. *Ibid.*, 181.
9. Nineteen Lancasters, each with a crew of seven, bombed a target marked by Cheshire in a Mosquito with a crew of two: 617 Squadron ORB.
10. II, 293.
11. 55,888; 47,268 of them on operations. Webster and Frankland, III, 286–7.
12. *Ibid.*, II, 12.
13. Churchill to Cranborne, 25 January 1944; *Second World War*, V, 602.
14. From an SOE file.
15. *Normandy to the Baltic* (1954) and *Memoirs* (1958), compare the solitary and ambiguous reference in his dispatch, *London Gazette*, 4 September 1946, 4433.
16. Paper by Brooks Richards and Ayer, 7 October 1944, sent that day to London by Duff Cooper; from an FO file.
17. *Ibid.*
18. F. E. Morgan and Bedell Smith to combined chiefs of staff, 18 July 1945, secret.
19. *Ibid.*
20. Langer, *Our Vichy Gamble*, is the vital source.

APPENDIX A

1. *A Study of History*, XII, 114 (1961).
2. Duncan Stuart's valuable paper on what happened to the archives, read at an SOE conference at the Imperial War Museum in 1998, still awaits publication.
3. Mackenzie, *History of SOE*, xxviii.
4. This reference is owed to Kenneth James.
5. This reference is owed to Gillian Tindall.

APPENDIX C

1. *History*, XXIV, Appendix D, revised summary.
2. *Passy*, 619–20.
3. *History*, XXIV, A, 1944, Appendix A, 10.
4. *Ibid.*
5. Cf. page 122.
6. *History*, X, Warington Smyth's paper, I; war diary, 2633; notes of 17 and 25 January 1943 in an SOE file.
7. RF war diary, 333; CARPENTER.
8. *Ibid.*, 334; COOK.
9. SOE files.
10. This table is based on appendixes H1, H2, and I2 of *History*, IX, AL section, drawn up just after the war by Mrs Wollaston from AL section's and AI2(c)'s records; a few random cross-checks with the special duty squadrons' ORBs confirm her figures.
11. *History*, XXI VA, 1944, Appendix A, 13.
12. From *History*, IX, AL section, Appendix H1, H2.
13. Craven and Cate, *Army Air Forces*, III, 503–5
14. *History*, IX, appendix H2, has 2,286 for this operation; table VII has been amended accordingly to agree with Craven and Cate.
15. SHAT 13P60.
16. *Nous, les terroristes*, I, 275–7.
17. From *History*, XXIVA, 1944, Appendix A, 15–16.

APPENDIX D

1. In *History*, IXE, appendix 5 (iii). Snapshot of Verity in Livry-Level, *Missions*, at 65.
2. This was not in France.
3. Verity himself (*History*, IXA, Appendix 5 (i)).

APPENDIX E

1. SOE translation made in 1941, in Moulin PF.
2. Stead, *Second Bureau*, has many details.

Index

Bodies referred to by their initials in the text are indexed accordingly, not under their full names; e.g. RAF comes between Radio and Rafferty, not between Rowlandson and R/T.

People are normally indexed under their real names, when known, with cross-references from their field names; a few of the best-known cover names appear also. English double-barrelled names are indexed under their first part e.g. Chalmers Wright under C, not W. Figures in brackets after names refer to successive missions into France arranged by SOE.

Decorations – British only are shown – were held during the war of 1939, or conferred (unless bracketed, thus) for services in it. The state of SOE's files is such that this record of them cannot be quite complete.

As in the text, most ranks are omitted; field names are in *italics*; and code names of circuits and operations are in SMALL CAPITALS.

- Abbott, G. W., 173–5, 373
Abel, *see* Fucs
Abelard, *see* Dupont
abrasive grease, *see* weapons
Abwehr, *see* security forces, German
ACOLYTE, F cct, 255, 261, 329, 466–7
ACROBAT, F cct, 189, 255–6, 415, 467
ACTOR, F cct, 333, 360, 466–7
ADE, xiii, 159, 236
AD/E, 21, 24, 27, *see also* Mockler-Ferryman
Adèle, *see* Jullian; Le Chêne, M-T
ADJUDICATE, EU/P mission, 159–60, 170
administration, SOE's, *see also* finance; supply: 11–12,
13–20, 41–52, 327–8
French, 122, 124–5, 311, 367
Admiralty: British, 61–6, 149, 172, 223, 248, 389
German, 236
Adrian, *see* Boden
Agapov, P., 331
Agazarian, F., 260, 275, 278, 279, 415
Agazarian, J. C. A. 275, 278, 300:(1), 179, 261, 266; (2),
263, 286; arrest and heroic silence, 286–7
Agen, Lot-et-Garonne, 180, 243
agents, SOE's: accent, 51–2, 254, 255–6, 272, 279,
353; 'amateurism', alleged, 56–7, 197, 201–2, 227,
283; characteristics, x, xi, xxii–xxiii, 47–8, 50, 56,
112, 221, 276; class origins, 48–50, 161; next of
kin, 43–5; pay, 46; recruiting, 20, 41–3; sent to
Germans in error, 83, 291–2, 293, 302–3, 324,
360–1, *see also* NORTH POLE; women as, 47–8, 289,
376, 414–8; *see also* FANY; names listed; WAAF
AI 2(c), 74
AI 10, 13, 43
Ain, 314–15, 328, 362
air landing, *see* pick-ups
air mail, *see* communications, SOE's
Air Ministry, 19, 43, 74, 256, 265, 267, 395
air policy, *see* strategy
air supply, *see* supply
aircraft: factories, *see* targets

- aircraft:
 American, 74, 83, *see also* pick-ups, Dakota; USAAF
 British: availability, 71–5, 211–12, 313; casualties, 80,
 383, 384; Lysander, 83, *see also* pick-ups; Whitley,
 75, 141, 144, 149
 factories, *see* targets
 German: used against SOE, 346, 361, *see also* targets
- Aisner, *see* Besnard
- AL section, 20, 30, 74, 208, 261, 339, 499n47
- Alain*, *see* Duboudin; Raynaud
- Alanbrooke, *see* Brooke
- Albanais*, *see* Somers
- Albert*, *see* Brouville; Cottin; Floiras
- Alexandre*, *see* Wilkinson, E. M.
- Alexandre, R. E. J., 302
- Alfred*, *see* Floege
- Alfred, King, 64
- Algèbre*, *see* Ely
- Algiers, xxiv, 23, 128, 198–9, 212, 316, 321, 333,
 345, 349, 363, 470, 498n10, *see also*
 MASSINGHAM
- Alice*, *see* Lefort
- Allainmat, J, 205
- Allard, E. A. L., 335
- ALLIANCE, SR cct, 197, 295
- Allington, N., 360
- ALOËS, mission, 135, 354, 358
- Alphonse*, *see* Brooks
- Alsace, 7–8, 293, 438, 439, 501n15
- Altesse*, *see* Marcellly
- amateurism, 56–7, 197, 201–2
- Amboise, Indre-et-Loire, 260, 262, 450
- Ambroise*, *see* Bloch, D
- ambushes, 6, 314, 346–9, 357, 371; German, 434
- American agents, *see* JEDBURGHs; OGs
- AMF section, xxi, 32, 122, 134, 355, 420; files burned,
 x, 396
- AMGOT, 367
- Amps, J. F., 178, 275
- Andorra, 92, 251
- Andrée*, *see* Borrel
- ANDY JEDBURGH, 123, 353
- Ange*, *see* Marchand
- Angers, 108, 178, 231, 232, 261–9, 279
- Angoulême, 248, 333, 428
- Anncy, Haute Savoie, 189, 197, 229, 314, 327, 328
- Annette*, *see* Cormeau
- Antelme, J. F. A., OBE: (1), 112, 200–1, 231, 249, 260,
 275, 297, 301; (2), 232, 261, 277, 279, 281, 287,
 292, 325, 494n53; (3) disastrous, 83, 291, 302–3,
 304–7
- Antibes, *see* Riviera
- anti-communism, 126, 250, 333, 390–1
- anti-fascism, 50, and *passim*
- Antoine*, *see* Antelme; Malval
- Antwerp, 289
- ANVIL, *see* DRAGOON
- Anzio, landing at, 222
- Apollo*, *see* Schelle
- Appleyard, J. G., DSO, MC, 141, 168–9, 400
- Aptaker, B., 332
- AQUATINT, raid, 168
- Arabs, 3, 6
- Archambaud*, *see* Norman
- ARCHDEACON, abortive F cct, 279, 281, 291, 293–4, 303,
 305, 307, 343, 467, 499n56
- archives, SOE's, x, 25–6, 395–8, 498n38; and cited,
passim
- Ardennes, 92, 131, 151, 322, 354
- Arend, R., 282
- Arisaig, 53–4, 201
- aristocracy: British, 48–9; French, 49–50, 123, 161
- Aristide*, *see also* Landes; Sicot
- Arles, 165
- ARMADA, RF cct, 49–50, 135, 222–4, 322, 330, 381,
 384, 470
- Armagnac, battalion d', 87, 362
- Armand*, *see* Dumont-Guillemet
- Armée gaulliste volontaire, 152, 186
- Armée secrète, *see* secret armies, gaullist
- Armistice, 1940, xx, 120–1, 184, 438, 442, 498
- arms, *see* supply; weapons
- Army
 American, 343, 361–3, 367, 368–9, 370, 374, 390
 British, 343–4, 368–9, 390; used by SOE as cover, 43
 Free French, 206–7, 363, 365–6
 German, 351, 359, *see also* targets; Waffen-SS; 157th
 Division, 347; II Panzer division, 361; *Lehr-Regiment*
Brandenburg, 343
 Soviet Russian, 145–6, 390
 Vichy French, 121, 123, 181, 184–5, 188, 197, 207,
 212; useless, 206
- Arnaud*, *see* Christmann; Maury; Rabinovitch
- Arnault, C., 332
- Arnolphe*, *see* Morandat, Y.
- Aron, J. M., 182, 192, 230
- Aron, Robert, 400; cited, 219–20, 340, 498n38,
 499n46, 502n79
- ARQUEBUSE, RF mission, 213–14
- Arras, 221, 238–9
- Arrosoir*, 223
- Arsène*, *see* Simon, O. A. G.
- ARTHUR JEDBURGH, 76
- ARTIST, proposed F cct, 180
- assassinations, 6, 140, 160, 164, 173, 198–9, 214, 230,
 322, 325, 360, 381, 439, 442
- Astier de la Vigerie, baron E. R. d', 23, 126, 184, 187,
 198, 206–7, 253, 311, 400; also cited, 441,
 498n35, 499n47, 500n82, 502n80
- Astier de la Vigerie, H. d', 198
- ASYMPTOTE, RF mission, 320
- Atkins, V. M., 43, 46, 100, 337, 500n97; after war, 282,
 307, 494n79, 497n189, 503n16
- atomic weapons, 15, 135, 471
- atrocities, 346, 351, 362, 388, *see also* concentration
 camps, German; torture
- ATTLA, invasion, xxi, 66, 128, 193–200, 206–8
- Atlee, C. R. (earl), 126, 311, 471
- ATTORNEY, abortive F cct, 188, 466–7
- Aubrac, L. and R., 215, 400
- AUDITOR, F cct, 361, 467
- Audouard, G. H., 187
- Australians, 171–3
- Austria, 3, 375, 498, 501n15
- AUTHOR, F cct, 251–2, 333, 466–7
- AUTOGIRO, F cct, 127, 131, 149, 153, 159, 173–5, 181,
 246, 251, 466–7, 470, 496n145
- Auvergne, 49, 157, 322, 354
- Auxerre, 152
- Aveyron, 360
- Ayer, A. J., 369, 503n3
- Ayral, J., 203

- Babington Smith, C., 400
Baignoire, see torture
 Bailey, see Baseden
 Baissac, C. D. de, DSO: (1), 179–80, 248–51, 258, 260, 275, 310; (2), 262, 263, 279, 281; (3), 304, 336, 350, 359, 386
 Baissac, L. de, see Villameur, Mme. L.
 Baissac, M. K. de, 180, 414
 Baker Street, SOE Headquarters in, 40, 244, 253, 256, 261, 334, 395–6, 396
 Balachowsky, A., 230, 281, 298, 375
 BALACLAVA, SOE base, 66–7
 Baldensperger, J. A., 354
 Balmaceda, G., 143, 414
 Barbie, 215, 221
 Barcelona, 88, 102, 170, 289, 323, 385
 Bardanne, J. Bouret de la, 158, 194
 Bardet, R., 225, 227, 244–5, 262–3, 263–4, 267, 270, 275, 326–7, 361, 367, 494n72
 BARDSEA, Polish plan, 25, 322, 351–2
 BARGEE, abortive F cct, 293, 305, 467
 Barrett, D. J.: (1), 243, 263, 275, 286; (2), 326, 360, 375
 Barry, R. H., OBE, 20, 32, 49, 140, 144, 339
 BARTER, RF raid, 152, 205
 Baseden, Y., MBE, 329, 416; arrested, 361, 378; rescued, 373, 377–8
Basil, see Lake
 Basin, F MBE, 157, 184, 187, 191, 230
 Basset, M., 326
Bastin, see Clech, M.
Baudoin, see Bollaert
 Baudot, M., 326, 400, 503n7
 BBC, 102, 146, 198, 365
 messages, 69, 74, 103, 153, 256, 264, 341–4, 448;
 originated by Bégué, 149; betrayed, 249, 270–1, 342
 BCRA, 23–4, 201, 213–14, 218, 314, 319, 390, see also RF section; and unifying resistance, 205–8
 BCRAL, 24, 33, 318, 339
 BCRAM, 23, 204
 Beauclerk, R. C., MBE, 333
 Beaulieu, 55–6, 95, 104, 226, 285, 298, 300, 302, 332
 Beaumont-Nesbitt, F. G., CVO, CBE, MC, 5, 8
 Beauregard, A., 329–30
 Beauvoir, S. de, 400, 501n22
 Beckman, Y. E. M., 99, 200, 240, 262, 415; arrest, 324, 378; killed, 377
 BEGGAR, F cct, 326, 467
 Bégué, G., MC: dropped, 147–8; in France, 148–9, 153, 156–7, 161, 171; arrest, 157; escape, 183, 231; in F section HQ, 101, 183, 303
 Belfort, 243, 254–6, 371
 Belgians, Belgium, 60, 87, 172, 174, 178–9, 237, 279, 324, 335, 359, 373, 386, 498
 Benes, E., 129
 BENJOIN mission, 322
 Benoist, M., 288
 Benoist, R. M. C., 176, 262, 287–8; (1), 233, 262, 264; (2), 336, 360, 447–50
Benoit, see Cowburn; Maugenet
 BERGAMOTTE mission, 347–8, 354
 Bergé, G. R. P., MC, 141, 151, 161
 Bergeret, 500n85
Bernard, 148, see also Astier, E. d'; Kawalkowski; Skepper
 Bernard, V., 138
 Berry, 48
 Bertaux, P., 151, 369, 370
 Bertholet, R., 143, 196
Bertrand, see Pickersgill
 Besançon, 327
 Besnard, J. M. L., 260, 262, 272, 286, 415
 BÊTE NOIRE LA, group, 152, 160, 243, 357
 Beugnon, R., 326
 Bevin, E., 389
Bibantoin, see Meric
 Bichelot, R., 234
 bicycles, 96, 265
 Bidault, G., 219–20, 365
 Biéler, G. D. A., DSO, MBE, 237, 239–40, 262, 275, 283, 296, 307, 310; arrest, 324; unforgettable, 200, 373
Bienvenue, see Lagier
Billet, see Holst
 Billotte, P., 207–8
Binette, see Petitjean
 Bingen, J., 216, 220, 320
 BIP, 219
 Birch, C., 113–14
Bishop, see Bloom
 Bitner, C., 141–2
 Bizot, R., 197, 246
 Black, A., 173, 174
 black market, see rationing
 Blacker, L. V. S., OBE, 5
 blackmail, 257
Blaise, see Diacono
 Blanc, M-L., 187
Blanche, see Butt; Charlet
 Bleicher, H.: in Abwehr, 108, 267, 361, 401; and AUTOGIRO, 159, 171–5; and DONKEYMAN and INVENTOR, 244, 263, 267, 361; and FARRIER, 260, 267, 271, 277; and SPINDLE, 225–6
 Bloch, A. G., 156, 158, 174–5
 Bloch, D., 360, 378, 416, 449
 Bloch, J-P and Mme, 157, 161, 183
 blockade-runners, see targets, ships
 Blois, 240, 336–7, 433
 Blondet, L. A., 83, 360
 Bloom, M., 197, 245–6
 bluff, 70, 96, 100–1, 238, 246, 263–4, 359
 BOA, 203, 218, 311, 319, 364, see also supply, air
Bob, see Starr, J. A. R.
 Boden, Karl, 277–8
 Bodhaine, de, 204, 354
 Bodington, N. R., MBE: (1), 97, 180–1, 184, 189–90, 193; (2), 249, 262, 263, 267, 271–3, 286–7, 299, 493n48; (3), 359; character, 49, 185; in London, 173, 192, 270, 303; voyages, 157, 172–3, 187, 368
 BODYGUARD, deception plan, 310
 Boemelburg, H., 109, 269, 271, 277
 Bohec, J., 418
 Boisson, P. de, 198
 Boiteux, R. R., MBE, MC: (1), 192, 193, 255; (2), 331–2, 500n91
 Bolladière, P. de, 322, 500n87
 Bollaert, E., arrest, 319–20
 Boltin, E., 39, 145
 Bomber Command, see RAF
 BOMBPROOF, F drop, 148
 Bonnier de la Chapelle, F., 198–9
 Bonoteau, Col., 261

- Bony-Lafont gang, 264, 270
 BOOKMAKER, F raids, 171, 466–7
 books on SOE, xii, 25, 398–413, 495n98
 Bordeaux, F and, 26–7, 149, 157, 158, 175, 179–80, 242–3, 248–51, 333, 360, 370; de Gaulle at, 108, 120, 166, 369–70; RF and, 144, 151, 202, 333
 boredom, 97, 227
 Boris, G., 312
 Borosh, H. MC, 105, 264, 329
 Borrel, A. R., 143, 179, 230, 276–88, 414; killed, 283, 376
 Bouchard, H., 326
 Bouchardon, A., 231–3, 327
 Bouguennec, *see* Garel
 Boulanger, G. E. J. M., 129, 502n75
 Boulogne, 8, 141, 188
 Bourbon, F. X. C. M. A. J. de, 401, 482n29
 Bourdat, 205
 Bourdon, M., 478n54
 Bourguès-Maunoury, M. M. J., 319, 321
 Bourgoin, P., 357, 358
 Bourne-Paterson, R. A., 49; cited, 186, 248, 291, 497n202
 Boxshall, E. G., MBE, xii
 Boyle, A. R., CMG, OBE, MC, 19, 101, 268, 382
 Bracken, B., 9, 18
 Braddon, R., 322
 BRAL, *see* BCRAL
 Brault, G. E., 203
 Brault, M., OBE, 131, 221, 312–13, 315, 318
 Bren guns, *see* weapons
 Brest, 144, 358, 368, 370
 Briand, *see* Brossolette
 bribery, 221, 272, 280, 299
 BRICKLAYER, F cct, 180, 258, 261, 277, 416, 466–7; betrayed, 306, 336
 Brittany: DF and, 60, 67–70, 420–1; F and, 138, 147–8, 297, 303, 336, 420–1; gaullists and, 141, 147–8, 152, 201, 233–4, 319, 352, 354, 498; SAS liberate, 355–9
 Broad, R., MC, 354, 371
 broadcasts, 186, *see also* BBC; radio &c.
 Brome, V., 401; cited, 480n162, 483n30, 483n37, 494n72
 Bronstein, L. D., 16, 115, 367
 Brook, R., CBE, 17, 21, 49, 60, 216, 298, 312, 344, 359, 500n4, 501n9
 Brooke, Sir A., KG, GCB, OM, DSO (Lord Alanbrooke), 173, 207
 Brooks, A. M., DSO, MC, 276, 453; (1), 127, 195–7, 246–7; (2), 113, 133, 329, 362
 Brossolette, P., in London, 213, 253, 482n24, (1), 213–15; (2), 215–22, 310, 319–20, 338; arrest and death, 320
 Brouville, comte A. J. R. Maze-Sencier de, DSO, 327
 Browne-Bartroli, A. J., DSO, 255, 262, 329
 Browne-Bartroli, E., *see* Plewman
 Broz, J., 312
 Bruneval, Seine-Inf, 166, 173
 Brussels, 70, 107, 277, 289
 Buchan, J. (Lord Tweedsmuir, GCMG, GCVO, CH), 131
 Buchowski, J., DSO, 65
 Buckmaster, M. J., OBE; at Dakar, 483n16; T section, 162; head of F section, 21, 28, 52–3, 101, 164, 183, 225, 267–8, 271, 277, 286, 298, 334–41, 337–8, 341, 470; deceived by Goetz, 298–307; deceived him, 291–2, 304–7; and casualties, 43–5; in EMFFI, 32; promoted colonel to go on JUDEX, 45; after 1944, 45, 279, 397, 495n102; as author, 26, 274, 293, 401, 476n36, 487n66, 500n97; also cited, 476n52, 477n31, 481n199, 484n60, 487n62, 499n62, 500n105
 BUICK, *see* USAAF
 BULBASKET, SAS party, 350, 356, 407
 Bulgare, *see* Gruner
 Burdeyron, N. F. R., 153, 161, 175, 373
 Burgundy, 193–4, 255–6, 265, 293, 329
 Burhou, Alderney, 168
 Burney, C. A. G., MBE: in France, 175; in Buchenwald, 175, 255, 374, 401; also cited, 273, 401
 business men, 21, 48, 161, *see also* capitalist
 BUTLER, F cct, 231, 258, 275, 283–4, 291, 296–7, 303, 305, 307, 341–2
 Butt, S. E. F., MBE, 417
 Byck, M., 337, 417
 Byerly, R., 302
 Cabard, R. P., 144–5
 Cabinet, *see* War Cabinet
 Cadett, T. T.-E., 144, 148; resigns, 162
 CADILLAC, *see* USAAF
 Cadogan, Sir A. G. M., GCMG, KCB, 5, 29, 121, 317
 Caen, 151, 154, 175, 361, 367, 387
 Caesar, C. Julius, 134, 257
 CAF, 418
 Cagoulards, 126, 441
Cahiers de l'Iroise, cited, 482n22, 499n42
 Cahors, 189, 351
 Calais, 128, 310, 385
 Calmette, A., 401
 Caluire, Lyons, 164, 349, 470
 Camargue, Bouches-du-Rhône, 60, 155, 194, 332
 Cambridge, 49, 72, 130
 Cammaerts, F. C. A., DSO: (1), 68, 97, 103–4, 127, 254, 263, 276, 298, 337; (2), 43, 77–8, 146n54, 310, 315–16, 344–6, 362–3, 379; impeccably secure, 226–7; security pays, 330–1
 camouflage, 72, 96, 324
 Canada, 60, 168–7, 279, 281, 290, 293, 302, 329
 Canadian, the false, 325
 canals, *see* targets
 Canaris, W., 107–8
 Cannon Brookes, V., 19
 CANTINIER mission, 257, 315, 354
 capitalist interests, supposed: American, 389; British, 39, 49, 146; French, 161, 317
 Caraman Chimay, princesse de, 161
 Carcassonne, 93, 254, 332, 361
 Cardozo, B. H., MC, 322
 carelessness, agents', 178, 197, 203–4, 225, 227, 233, 253–4, 273, 298–9, 335
 Carnadelle, Mmc., 289
Carpi, *see* Paimblanc
 CARPETBAGGER, *see* USAAF
 Carré, M., 131, 159, 171–5, 267, 312, 401
 CARTE, abortive F cct, 134, 179, 181, 183–91, 191, 195, 201, 224–5, 258, 273, 275, 420, 466–7
Carte, *see* Girard
 Cartigny, J. L., 151
 CARVER, F cct, 333, 467, 481n13
Casimir, *see* Beauclerk; Sreni

- casualties: French civilian, 343, 366, *see also* reprisals;
 SOE's, 21, 33, 43–5, 67, 174, 372–3, *see also* aircraft
- Cat*, *see* Carré
- Cate, *see* Craven
- Catroux, G., GCB, 125
- Cauchi, E. J., 256, 327
- Cauchi, J. M., 231
- Caza, R., MC, 329
- CCO, 29, 64, 165–9, 176, 210, 371
- CD, 18–20, 34, 470, *see also* Gubbins; Hambro; Nelson
- CDLL, group, 214
- Celestin*, *see* Stonehouse
- cells, *see* tactics
- CEO, 19, *see also* Jebb
- Cérat*, *see* Parodi
- César*, *see* Réce
- Cevennes, 354
- CFLN, 311, 317–18, 320, 367; becomes provisional government, 321
- CFR, 476n43
- CFTC, 153, 161
- CGE, 320
- CGT, 161
- Chaban-Delmas, J., 319, 321
- Chaillan, *see* Bardet
- chain of command
 above SOE, 28–30, 32–3, 34
 in France, *see* DMN; DMZ; centralization dangerous, 41, 216–21
 within SOE, 16–30, 31–3, 34, 97, 271
- Chaingy, Orleans, 231, 455
- Chaland*, 322
- Chalmers Wright, F., MBE: (1), 94, 187, 480n144; (2), 323; cited, 483n31
- Chalons-sur-Marne, 7, 283
- Chambe, R. M., 188
- Chamberlain, A. N., 5, 9–10, 119, 123, 136
- Chambrun, *see* Churchill, P. M.
- CHANCELLOR, F cct, 51, 327, 337, 342, 370–1, 467
- Channel Islands, 64, 168–9
- Chantraine, O., 156, 177, 253
- Chapman, R. A., 104
- Charente, 248, 428
- Charles*, *see* Bertholet; Grover-Williams
- Charlet, V. B., 193, 414
- Chartier, G., 205
- Chartrand, J. C. G., 234, 263, 283–4
- Chartres, 163, 297, 302, 304, 336, 417
- Châteauroux, 148, 149, 157, 177, 181, 253, 261, 325, 327, 342
- Chatte, La*, *see* Carré
- Chavant, 345
- Cherbourg, 137, 168, 340, 368
- CHESTNUT, F cct, 176, 233, 258, 287–8, 299, 336, 466–7
- Chevigné, Col, 343
- Chiefs of staff: British, 8, 29–30, 34, 150–1, 185, 211, 311, 398, *see also* directives; Combined, 34, 197–9, 210; SOE's, 20, 34
- children, a danger, 91
- Chile, 143, 414
- China, 4, 9, 71
- Choltitz, D. von, surrenders Paris, 364–5
- Choremi, A. C., 76
- Christiane*, *see* Charlet
- Christmann, R., 278–9, 288–9
- Christophe*, *see* Tessier; Turck
- Churchill, (Lady) C., GBE, 311
- Churchill, O., *see* Sansom
- Churchill, P. M., DSO: and submarines, 62, 170, 177, 183–4; as liaison officer, 86, 186–7, 195, 230, 328, 414, 485n104; arrest, 225–6, 267, 373; also cited, 86, 401–2, 476n46, 476n55, 477n12, 479n120, 485n89, 487n66
- Churchill, (Sir) W. L. S., (KG), OM, CH: xx, 17, 64, 365, 378, 386, 389, 400, 401, 438, 468; launched SOE, xx, 8–10, 13–14, 119, 381; sustained it, 18, 131, 150, 311–14, 382; and de Gaulle, 126, 129, 213, 317, 321, 340; also cited, 120, 402, 483n42
- Cicero*, *see* Malraux, C.
- CINEMA, F cct, *see* PHONO
- cipher, 42, 55–6, 97–101, 152, 267, 293, 321
- CIRCONFERENCE, RF cct, 418
- circuits: defined, 21; organization, 112–13, 162; time chart of F's, 133, 466–7; varying size, 133
- Citrine, Sir W., 189
- CITRONELLE mission, 322, 354, 500n87
- CIVETTE mission, 354
- civil power, French, xxiv, 164, 207–8, 366–72, 443
- civil service, French, 122, 125, 152, *see also* CGE; NAP
- class divisions, xxii, 48–50, 160–1
- Claude*, *see* Déricourt
- Clay, H. L. de, MM, 204
- GLE mission, 320–1
- Cléante*, *see* Bingen
- Clech, M., 138, 177, 260, 261, 264, 267, 275, 300, 450–2, 500n103
- Clement*, *see* Liewer
- Clement, G., 233–4
- Clement, M. R., 264, 268, 272–3
- CLERGYMAN, F cct, 232–3, 262, 336, 360, 416, 447–50, 466–7
- Clermont-Ferrand, 191, 254, 257, 320, 327
- CND, 59, 139
- CNR, *see also* COMAC: set up, 213–14, 470; rebuilt, 219–20, 367; broken up, 214–15; split from delegation, 219, 318; and Paris rising, 364–5
- coastal areas, 8, 60–1, 64–71, 165–9
- Cochet, G. R., 23, 125, 345, 441
- COCKLE, RF cct, 205, 222
- cod, RF cct, 153, 205
- code names, 499n47, 500n87
- codes, 55–6, 90–1, 98, 102–4, 113, 159, 192, 272, 277, 294, 298–9, 301, 387, 449–52, *see also* BBC messages; ciphers; passwords
- 'coding row', 215–16, 321
- Cohen, G. A., MC: (1), 282–3, 286, 299, 494n65, 495n95; (2), 322–33
- COHQ, *see* CCO
- Colditz, fortress, 174, 374
- Cole, H., 495n91
- Coleman, J. H. MBE, 255, 303
- Colette*, *see* Walters
- collaborators, French, with Germans, 161
- Collins, L., 402, 498n38, 502n70, 502n72
- COMAC, 318, 364
- COMBAT, movement, 133, 190, 202, 206, 312, 404, *see also* FRANCE AU COMBAT
- COMIDAC, 498n34
- 'Commando order', 168–70
- Commando raids, 8, 26–7, 61, 64–6, 67, 165–9, 173, 210; made no contact with resistance, 167, 169–70

communications

- German, *see* targets
- de Gaulle's, 66; in France, 103–5, 444–6
- SOE's, 59–60, 132, 171, 202–3; by air, 71–87, *see also* BOA; parachuting; pick-ups; SAP; by air mail, 178, 270, 276–7; by land, 87–94, *see also* VIC; by post, 89–90, 95, 105, 450, 451–2; by sea, 60–71, 147, 172–3, *see also* LAFFITE; VAR; by signal, *see* wireless
- Communist party, French, 103, 111, 124, 127, 146, 160, 163, 205; and Darlan affair, 198–9, 214, 219, 251, 283, 311, 318, 334, 349, 364, 367, 385, 390, 441, 470
- Communist party, Soviet Russian, 119, 163, 198, 390
- concentration camps
- French, 110
- German, xxv, 71, 191, 373–5, 471; Belsen, 373, 379, 414; Buchenwald, 71, 152, 175, 255, 282, 292, 294, 361, 374–5, 378, 401; Dachau, 76, 99, 143, 193, 301, 377, 415, 500n82; Dora, 152; Flossenbürg, 108, 254, 287, 373; Gross Rosen, 194, 251, 306–7; Mauthausen, 193, 307; Natzweiler, 193, 283, 376–7, 414–16; Ravensbrück, 68, 142, 301, 360, 376, 377–8, 414–18; Ravitsch, 294, 297; Sachsenhausen, 287
- Spanish, 94, 375
- conducting officers, 53, 57–8, 322, 430
- cone, RF cct, 418
- CONJUROR, pick up, 263, 270, 493n40
- Connerade, G., 224
- containers, 76–8, 423–6
- controls, 51, 96, 141, 143, 178, 388
- Conus, A., 345–6
- Coolidge, F., 354
- COONEY, SAS raids, 357
- Cooper, *see* Duff Cooper
- COPA, *see* SAP
- Coppin, E. C., 194–5, 226
- Corbin, C. H. L., MC, 110, 250
- Corge, A., 418
- Cormeau, Y., MBE, 103, 254, 415
- Cornioley, H., 331, 500n97
- Cornioley, P., *see* Witherington
- Corrèze, 251–2, 333, 354
- Corsica, 66, 188, 205, 291, 316, 420
- CORSTICAN, F mission, 157, 183, 466–7
- Cosmo*, *see* Lesage
- COSSAC, 212, 341
- Cottin, R., 148, 153, 156, 174–5, 373
- Coulaudon, E., 322
- Council, SOE's, 27–8
- counter-espionage, *see* security forces and services
- counter-scorching, 60–1, 176, 344
- country sections, what, 20–1, 40, *see also* F, H, N, RF, T
- couriers, 47–8
- Courtaulds, 21
- cover, 13, 39–40, 43, 46, 102–3, 249, 253–4, 286, 310, 444–6; names, 57; stories, 68, 112–13, 147, 170, 280, 449
- Cowburn, B. H., MC, 276, 326, 399, 402; (1), 156, 158, 173, 253; (2), 177–8, 193, 228; (3), 112, 127, 240–3, 262–3, 275, 286; (4), 111, 360, 482n39; also cited, 87, 130, 158, 478n67, 479n109, 481n193, 484n81
- Craven, W. R.: and Cate, J. L., 402; cited, 478n61, 479n98, 479n107
- Crayfish*, 203–4
- Creil, Oise, 325–6
- Crétin, 289
- Croft, N. A. C., DSO, 66–7, 354
- Croix, J. de la, 345
- CS, sub-department, 4
- Culioli, P., 229, 240, 270, 277, 279–80, 281, 292
- currency, 122, 178, 203, *see also* finance
- Cusin, G., 369
- Cuthbert*, 200
- cut-out, 88–90, 281, 331, 502n70
- CUT-THROAT, mission, 76, 354, 371
- Czechoslovakia, 119, 390
- Czerniaswski, R. Garby-, OBE, 402, 484n81, 485n110
- D, section: founded, xx, 4, 468; active, 52, 138, 154, 273; absorbed into SOE, 10–11, 137
- D Day, *see* DRAGON; NEPTUNE; OVERLORD
- Dakar, xxi, 139, 340, 470
- DAKS, WT plan, worked by Gemans, 306–7
- Daladier, E., 124, 181
- Dalton, E. H. J. N. (Lord): in charge of SOE, 9–14, 18–19, 161, 206–7, 468, 470; prejudices, 48, 129, 150, 165, 402
- Damerment, M.: in PAT line, 143; betrayed, 83, 302–7; killed, 377, 416
- Dandicolle-Renaud, J. M., 359
- danger signals, 335, 481n21
- Dansette, A., 402; cited, 178, 364–6
- Dansej, Sir C., 313
- Darlan, J. F.: helps Pétain, 123, 367, 381, 389–90, 441; helps Eisenhower, 198–9; assassinated, xxiv, 198–9, 213, 470
- Darling, G., 231, 280, 282–3
- Darnand, J., 110
- DASTARD, RF cct, 152
- David*, *see* Baissac, C. D. de
- Davies, F. T., 165
- DCO, *see* CCO
- DDOD(I), 64, 67, 69, 71
- deception, 6–7, 202, 249, 274, 302, 304–7, 310, 340–1
- decorations, 45–6, 48, 265, 335, 379
- Dédé*, *see* Defence, M.
- Dedieu, G., 304
- Defence, M., 249–51, 297
- Defence, Ministry of, 17, 29–30, 129
- Defence Committee, of War Cabinet, 17, 211–12
- Defendini, A., 104, 293–4
- Defoe*, *see* Deligant
- delay fuses, *see* weapons
- DELEGATE, abortive F cct, 297, 305
- delegation: gaullist, in France, 164–5, 206, 213–15; disjoined from CNR, 219, 319–21
- Delestraint, C. G. A., 204, 206, 213, 215, 316
- Delfanne, G., 59, 278
- Deligant, D., MBE, 142–3, 161
- Delphin*, *see* Lejeune
- Deman, E. P., MC, 68–78, 261
- Demarcation line, xxi, 143, 147, 245, 261
- demolitions technique, 5, 55, 323, *see also* sabotage; industrial, tabulated, 453–465
- Denier*, J., 90
- Denise*, *see* Borrel
- Deniset, F. A., 302
- derailments: for NEPTUNE, 341–2; occasional, 160, 174, 201, 209, 237–9, 297, 357; policy, *see* targets

- Déricourt, H. A. E.: 234, 236, 239, 244, 251, 286–8, 292, 299, 302, 311, 329; recruited, 259–60; missions, 259, 260–7 (table 266); loyalties, 85, 131–2, 260–1, 262–3, 266–73, 368; reported dead, 503n2
- Déricourt, J., 259–60, 265, 269, 329
- Deschelette, E., 350, 353
- Deshayes, P. M., 221, 338
- Despaigne, H. M. R., MC: (1), 194–5; (2), 254, 331
- Detal, J. T. J., 297
- DETECTIVE, F cct, 182, 192, 254, 327, 332, 466–7
- detonators, *see* weapons
- Deuxième bureau: de Gaulle's, xxiii, 23–4, *see also* BCRA; Pétain's, 181; third republic's, 7
- Dewavrin, A., DSO, MC: xii, 366in; BCRA, 23–4, 127, 128, 205–8, 214, 313, 320, 341, 375, 501n9; (1), 28, 213–14, 310; demoted, 318; in EMFFI, 23, 75–6, 140, 153, 161, 164–5; (2), 354, 358; cited, *see Passy*
- Devisselaere, A., 239
- DF Section: xxi, 21, 33, 45, 105, 111, 122, 134, 269, 396, 420; involved with Gestapo, 70, 209, 277–8; operations, 1940–1, 142–4, 146, 470; operations, 1942, 170–1; operations, 1943, 65–70, 224; operations, 1944, 32, 62, 70, 130, 322–3, 336–7; outline of work, 21, 87–94
- Dhose, Hauptsturmführer, 250
- Dhuizon, Loir et Cher, 279, 293
- Diacono, H. L. A., MBE, 324
- DIANA, German wireless game, 301–3
- Diane*, *see* Hall
- Dieppe, 65, 167, 168, 430, 470
- Diethelm, A., 23
- DIETICIAN, F cct, 326, 467
- Dieudonné*, *see* Chartrand
- DIGGER, F cct, 127, 333, 398, 466–7
- Dijon, 108, 132, 254–5, 294, 355, 357, 417
- Dill, Sir J., KCB, CMG, DSO, 137
- Ding-Schuler, E., 375
- DINGSON, SAS party, 357, 358
- DIPLOMAT, F cct, 243, 326, 342, 466–7
- direction-finding, wireless, 41, 96–7, 149, 153, 193, 203, 233, 234, 264, 287, 300, 324, 330
- directives to SOE, from COS, xxii, 10, 138, 176, 185, 209–12, 382
- DIRECTOR, F cct, 229–30, 329, 361, 482n41
- Dismore, L. H., 22, 33, 49, 221, 312, 320, 470, 501n29
- Dispenser*, *see* Michel, F
- DITCHER, F cct, 255, 262, 329, 466–7
- DMN, 319
- DMR, 218–19, 319, 326
- DMZ, 319
- Dodds-Parker, A. D., 32, 403
- Dok*, *see* Forman
- Dominique*, *see* Rafferty
- DONKEYMAN, F cct, 244, 258, 261, 263, 276, 326–7, 361, 364, 417, 466–7
- Donnison, F. S. V., CBE, cited, 366, 503n14
- Donovan, W. J., KBE, 31
- Dordogne, 123, 161, 244, 252, 362
- Dorner, H. E. J., DSO, 92, 113–14, 224, 351, 403
- Dorset Square, Marylebone, 22, 420
- Dorval, J., 247
- double agents, 41, 52, 171–2, 256, 258–9, 263, 268–9, 302, 325, 326, 335, 344, 356, *see also* Bardet; Carré; Déricourt; Kieffer, J. L.
- Dourlein, P., 54; cited, 403
- Dowlen, R., 260, 286, 287, 287–8, 296, 299
- D/R, 21, 161, 173, 304, 306
- Draftsman*, *see* Bloch
- DRAGON, invasion, xxv, 133, 343, 362–3, 371, 386, 388, 471
- DRESSMAKER, F raid, 224, 324, 466–7
- D/RF, *see* RF section
- Drôme, 229, 315
- Drouilh, H., 80
- Drummond, J. D., cited, 480n158
- Dubois, A., 225, 233, 237–8, 260, 286, 299, 375
- Duboué, 250
- Duboudin, A. J. R., 157, 184, 190–3, 227, 329
- Duchalard, C. J., 245
- Duclos, J., 390
- Duclos, M. F., 318
- Duclos, P. F., 297
- Duff Cooper, A. (Lord Norwich), DSO, 311, 389, 402
- Duke, M., 403, 480n150, 503n9
- Duke Street, Mayfair, 22, 126
- Dumont-Guillemet, R. A., DSO, 195, 262, 324–6, 338, 360
- Dunkirk, xx, 200, 389, 468
- duplication of names, 161, 258–9, 478n54, 478n85, 485n100
- Dupont, M. M. L., MC, 243, 326
- Dupuy, P., 60
- Dyer*, *see* Deman
- Dziergowski, T., MC, 94, 160, 177
- economic warfare, *see* MEW
- economy of effort, xxii, 62, 238, 256–7, 380–6
- Eden, (Sir) R. A. (Lord Avon), MC, 8, 11, 18, 128, 173, 198, 206–7, 337
- EDOUARD, DF line, 142, 143, 170–1
- Edouard*, *see* Clement, G.; Rizzo
- Eguzon, Indre, 178
- EH, sub-department, xx, 4, 11, 468
- Ehrman, J. P. W., 403
- Eisenhower, D. D., OM, GCB, 197–9, 318, 341, 358, 364, 387–8
- electric power, *see* targets
- Elie*, *see* Jones, S. C.
- Elizabeth*, *see* Rochester
- Ellipse*, *see* Deschelette
- Ellis, L. F., CVO, CBE, DSO, MC, 403; cited, 342
- Elm*, *see* Simon, A. L. E. H.
- Ely, P., 319, 321
- Emanuel*, *see* Caza
- EMFFI, xxiv–xxv, 25, 32–3, 130, 327, 339–40, 352, 355, 389, 396, 502n75
- Emile*, *see* Millar; Starr, J. A. R.
- End*, *see* Marsac
- England, *see* Great Britain
- Entente Cordiale*, 120–1, 282–5, 372, 389
- enthusiasm, at SOE HQ, 27, 137–8, 247, 303
- Eon, A. M., 354, 358
- equipment, *see* weapons
- Erainger, H. d', 262
- Ernest*, *see* Fox
- errors: agents', xi, 184, *see also* carelessness; German, 306–7, 308, 388–9, *see also* atrocities; SOE staff, xi, 173, 266–8, 292, 296, 300, 330, 339, 500n89
- escape lines: SOE's, 87–94, 130, *see also* DF; VAR; VIC; other allied, 39, 85–6, 87–8, 92–3, 239, 319–20; Spanish republican, 87–8

- escapes, 124, 142, 151, 181–4, 200, 232–3, 244, 254, 284–5, 287–8, 295–6, 297, 350, 356, 360, 374, 375
- Escoute, M., 75–6
- espionage, *see* intelligence, military
- Elat Français*, *see* Vichy regime
- ETOILE mission, 354
- EUGALYPTUS mission, 344–6, 354
- Eugène*, *see* Pertschuk
- EU/P section, *see also* Poles: 105, 134, 396; founded, 25, 470; in 1941, 34, 142, 143, 145–6, 159–60, 470; in 1942, 170; in 1943–44, 130, 323
- Eure, 326
- Eureka*, 81–2, 245, 322
- European Resistance Movements*, 403; cited, 145
- Eustache*, *see* Watney
- Eysses, Toulouse, 332, 360
- F section: 322; origin, xxi, 21, 470; objects, xxi–xxii, 21–2, 26; operations, 1940, failures, 138–40; operations, 1941, tentative, 144, 145, 147–9, 153; operations, 1942, varying, 207; operations, 1942, in ZNO, 180–97; operations, 1942, in ZO, 171–80, 200–1; operations, 1943, successful, 209, 224–5, 246–9, 251–7, 379; operations, 1943–4, dubious, 245–6, 249–52, 258–308, 310, 331, 343, 367; operations, 1944, failures, 327, 329–31, 344–6, 360–1; operations, 1944, successes, 310, 313–14, 319, 322, 324–6, 331–7, 341–4, 349–51, 359, 362–4; merged in FFI, 25, 33, 318, 337; ; fate of French citizens among agents, 337–8; surviving prisoners, 360, 373–4, 414, 416; staff, 43, 47, 101, 153, 177, 188, 261, 268, 284, 293, 296, 303, 334, 337–8; and RF section, *see* rivalries; winding up, 45
- FABULOUS, RF cct, 151, 202
- FACADE, F cct, 154–6, 466–7
- factories, *see* sabotage
- Faillé, *see* Faye
- Falmouth, 63, 64, 69, 138
- false documents, *see* forgery
- FANY, 48, 319, 322–3, 414–17, 485n91
- FARMER, F cct, 50, 200, 237–9, 243, 283, 324, 466–7
- Farmer, J. H., MC, 322
- Farran, R., DSO, MC, 356–7, 403
- FARRIER, F cct, 131, 258–73, 466–7
- Fassin, R. G. R., 202–3, 204
- Fauge, *see* Fontaine
- Faye, L., 295, 300–1
- Feldgendarmic, *see* security forces, German
- FELICITATE, a rescue, 64, 67
- Félix*, *see* Jones, S. C.
- Fenwick, I., 356
- FFI, xxiv, 318, 354, 365, 370, 470, *see also* EMFFI
- Fielding, A. W., DSO, 363
- Figéac, Lot, 333, 455
- film on SOE, 74, 233, 479n95, 479n120, 485n91
- finance of SOE, 17, *see also* currency; of EMFFI, 364, 419; of F section, 46, 189, 226, 231–2, 256, 302, 304, 331, 419–20, 449, 451; of RF section, 205, 420; of smaller sections, 420
- Fincken, J., 174, 373
- ‘fingerprinting’, wireless, 101–2, 292, 301
- Finlayson, D. H., 293–4
- Fiocca, N., GM, 322, 417
- FIREBRAND, invasion, 316
- FIREMAN, F cct, 334, 350, 363, 416, 467
- Fives-Lille, 238, 256, 456
- flair, clandestine, 158, 193, 217–18, 226, 329–30
- Flattot, A., 481n20
- Fleuret, M., 148, 157
- Floège, E. F., DSO, 232–3, 327
- Floiras, A., MBE, 228, 254
- Flower, R. H., 177, 260
- FN, 133, 146, 205, 214, 219, 220
- Foch, Avenue, Paris, 109, 264, 273, 282, 294–5, 300, 302, 350, 365, 378
- Fontaine, Y., 243, 263, 326, 416
- food, *see* rationing
- Foot, M. R. D., cited, 47, 167–9, 478n66
- FOOTMAN, F cct, 333–4, 363, 466–7
- FOPS, 150
- Foreign legion, 68, 171, 277, 315
- Foreign office, 4–5, 8, 11, 22, 129, 159–60, 171, 312, 321, 337, 370, 389; bans bangs, 29, 199
- forgery, 42, 88, 170, 178, 202, 278, 387, 395
- Forman, A., MC, 141, 144–5, 151, 165, 195, 202
- FORTITUDE, deception plan, 310, 340
- Fourcaud, P., DSO, 315, 500n87
- ‘Fourth Arm’ concept, 10–11
- Fox, M. G. F., 231, 283–4, 296
- Fradin, Mlle, 289
- Frager, J. H., 186, 187, 188–9, 224–5, 226, 227, 228, 244–5, 260, 262–3, 265, 267, 275, 276, 294, 326, 361, 375, 450–1
- FRANC-TRIEUR, movement, 206
- France, *see also* CFLN; civil power; resistance; Vichy regime: divided by defeat, 120–5; mass opinion in, 125, 129, 132, 146, 160, 199, 325, 364, 388–9; notionally represented by de Gaulle, 24; repudiates Vichy, 367–9; SOE’s aims in, xxii, 127–9, 390
- FRANCE AU COMBAT, groups, 334
- Franche-Comté, 354, 371
- Frankland, *see* Webster
- Franks, B. M., DSO, MC, TD, 323
- FRANKTON, raid, 26–7, 166, 180, 248
- Fraser, B., GM, 221, 239
- Fraser, W., DSO, 355–6
- Frédéric*, *see* Hymans
- FRELANCE, F cct, 322, 327, 417, 467
- Freemasonry, 16, 441
- Frenay, H., 202, 206
- Fresnes, Seine, prison, 152, 244, 294, 324, 350, 401
- Frisé, Le*, *see* Rigoulet
- FROMENT, intelligence cct, 334
- FTP, 127, 146, 179, 191, 193, 249, 252, 255, 318, 325, 336, 349, 360, 364, 370, 385, 390
- Fuchs, H., MC, 386
- Funkspiele*, *see* wireless games
- Gabriel*, *see* Bloch, J. P.; Young, J. C.
- Gaby*, *see* Plewman
- Gael*, *see* Johnson
- Gaillard, H. H., 339
- Gaillot, H. H., 233, 264
- GAIN, SAS party, 356–7
- Gaitskell, H. T. N., CBE, 17, 19
- Gale, (Sir) R. N., CBE, DSO, OBE, MC, 16
- Gambetta, L., 122, 322
- Ganay, J. L. de, 326
- GARDENER, F cct, 331, 466–7, 500n91
- Gardner, D., 76

- Garel, F., 154, 157, 183, 231, 234, 283–4, 296
 Garry, E. A. H., 281, 287, 297–301, 302
 Garry, M., 297, 301
 Garry, R., 299–300
Gariefish, RF agent, 204
 Gascony, 182, 189, 243, 245, 254, 332
Gaspar, see Flower
Gaspard, see Coulaudon
Gaston, see Burdeyron
 Gaudin, M., 204
 Gaulle, C. A. J. M. de: 184, 204, 246, 312, 321, 404; acclaimed in Paris, 365–6, 471; American distrust of, xxiii–xxiv, 213, 389–90; attitudes to SOE, 25, 26, 186, 201, 207, 213, 215–16; and CFLN, 212–13, 310, 316–17; character, 125–6, 207, 390; and Churchill, see Churchill, (Sir) W. L. S.; cited, 317–18; and DRAGOON, 363; emerges as national hero, 25, 32, 206–7, 214, 367–70, 389, 438; forms Free French HQ, 23–4, 317–18; originates resistance, xxi, 468; and OVERLORD, 339–40; and PCF, 213, 390; resistance policies of, 139, 164, 205–7, 214, 219, 253, 311, 317–19, 341, 343; and seizure of power, 207–8, 366–7
 Gaulle, Y. C. A. M. de, 138
Gauthier, see Vomécourt, Philippe de
 Geelen, P. A. H., 335
 Geneva, 196, 247
Geneviève, see Latour, P.
Geoffroi, see Watt
 George VI, KG etc, 73n, 365, 483n25
Georges, 174, see also Bégué, Bloch, A. G., Redding, G. C. B., Newman, Zeff, Clech
 Georges, R. M., 205
Germaine, see Hall
 Germany, see also atrocities; Nazism: driven out, 132–3; occupies ZNO, see ATLTA; occupies ZO, 120–5; threatens world security, 3
Géronte, see Bollaert
 Gerson, G., 143, 414
 Gerson, H. V. DSO, 143, 161, 321; (1), 156, 158, 162; (2), 170, 177, 262; (3), 171, 263, 289; (4), 290; (5), 143; (6), 143
Gervais, see Hazan
 Gestapo and GFP, see security forces, German
 Gianello, M., 418
 Gibraltar, 68, 94, 259, 273
 Gigny, Saône-et-Loire, 222–4
Gilbert, 259, 270, see Déricourt; Norman
Gilles, see Coppin
 Ginzburger, P., see COMAC
 Girard, A., 97–8, 184–9, 191, 195, 224–5, 226, 229
 Giraud, H. H.: escapes, 61, 125, 188, 197, 404; de Gaulle's rival, xxiv, 207, 212–13, 310; and TORCH, 197–8; fades out, 125, 316, 390
 Gironde, 139, 180, 248, 277, 332
 Giskes, H. J., 56–7, 278, 404; cited, 481n183
 Gladstone, W. E., 17, 49, 121, 148
 Glières, Ain, 328
 GLOVER, F cct, 337, 467
 Gmeiner, J., 376
 Göbbels, J., 125
 Goddard, L. F., 76
 Goetz, J., 109–10, 115, 246, 269–70, 277, 282, 286, 291–2, 292–3, 296, 301–2, 304; outplays Buckmaster, 290–304; outplayed by him, 291–2, 304–7
 GOLDFISH, abortive RF cct, 205
 Goldsmith, J. G., DSO, MC, 187–9, 260, 262
 GONDOLIER, F cct, 327, 466–7
 Göring, H., 306
 Gort, J. S. S. P. V., viscount, VC, KCB, CBE, DSO, MVO, MC, 5
 Gosse, R., 404
 Gouin, Mme F., 264
 Grand, L. D., CIE, CBE: head of section D, 4–8, 49, 52; left SOE, 137
 Grandclément, A.: changes sides, 249–51, 251, 258, 331, 333, 470; executed, 360
 Granville, C., GM, 363, 417
 Graven, see Gaudin
 Graves, R. R., 478n56
 Great Britain, policy towards France, xxiii, 120–1, 127–8, 390
 Greece, 22, 119, 145, 470
 Green, D. E. F., 347, 476n62
 GREENHEART, F cct, 192, 254–5, 466–7
Grégoire, see Le Chêne, P. L.
 Grégoire, 401
 grenades: hand, see weapons; ST, 5
 Grenier, E., 213
 Grenoble, 187, 246, 362
 GREYHOUND, DF line, 224, 323, 325
 Grierson, C. McK., 208
 Griffiths, F. C., DFC, AFC, 229–30, 327
 Gros, J., 418
 Grossard, Col., 439–41
 Grover-Williams, W. C. F., xv, 175–6, 275, 286, 287, 288
 Gruner, E., 418
 GS(R), see MIR
 Gubbins, Sir C. McV., KCMG, DSO, MC: xii, 49, 71; character, 20; in MIR, 5–7; in 1940, 42, 67; as M, 20, 52, 59, 61, 65, 140, 173, 20; as D/CD(O), 20, 170, 181, 198, 207; as CD, 18, 20, 131, 268, 311, 319, 337–8, 341, 346, 364, 387, 470; supports de Gaulle, 130; and COS, 29–30, 150–1, 173, 185; post-war papers cited, 95, 137, 405
 Guélis, J. T. P. M. Vaillant de, MBE, MC, 32, 128, 146, 167; (1), 154–6, 184, 194, 255; (2), 354, 482n39
 Guépin, R., 281
 guerilla: before 1939 war, 3–6, 9, 316; principles of, 5–6, 9, 316, 358–9, 385; proposed, 8, 131, 210–11, 313; in France, xxi, 77, 132–3, 135, 247, 309, 314, 344–7, 358–9
 Guérisse, A., GC, DSO, 143, 376, 401
 Guerne, A., 179, 280, 281, 284–5
 Guillaume, abbé P., 405; cited, 478n83
 Guillermin, H., 222–3
 Guingamp, Côtes du Nord, 357
 Guiraud, R. J., 337
 Gunzbourg, Baron P. de, 332, 350
Gustave, see Jickell; Sirois
Guy, see Biéler
 H section, 477n34
Hagfish, RF agent, 204
 Halifax, E. F. L. W. earl of, KG, GCSI, GCIE, 5, 9, 11
 Hall, V., MBE: (1), 147, 154–5, 157–8, 162, 173, 175, 177–8, 180–1, 183, 190, 192, 195, 200, 230, 414, 480n152; (2), 327, 416, 482n39
 Hallowes, see Sansom
 Hambro, Sir C., KBE, 18, 43, 185, 207, 211, 216

- Hamilton, J. T., 193
 Hankey, Sir M. P. A., lord, GCB, GCMG, GCVO, 8–9, 156
 Hardy, R., 215
 Harfleur, 8, 136
 Harratt, P., DSO, MC, 61, 65, 67–70, 167
 Harrington, Northamptonshire, 355
 Harris, Sir A. T., GCB, OBE, AFC, 15, 140, 211–12, 309, 313, 382
 Harrison, D. I., 405
Harrow, see Ayral
 Haskell, J., 387
Hastings, see Hutchinson
 Hastings, W. M., 354, 371
 Haukelid, K., DSO, 135, 405
 Hautecloque, P. F. M. L. de, see *Leclerc*
 Hayes, J. B. E., MC: (1), 157, 183; (2), 183, 359, 482n39
 Hayes, V. C., MBE, 180–1, 250–1
 Hazan, V. H., 191, 226
 Hazell, R., MBE, 25, 49, 169
 HEADMASTER, F cct, 194, 305, 332, 336, 350, 417, 466–7
 HECKLER, F cct, 414, 466–7, see also Hall
Hector, see Southgate
 Heim, A. G., 418
 Heimann, O., 171
Hélène, 278, see also Fiocca; Placke
 Helford river, 63–5
 helicopters, 479n114
Hélène, see Corge
 HELMSMAN, F cct, 359, 467, 482n39
 Henquet, R. R., 304, 336
Henri, see Bleicher
 Hérault, 332, 354
 Herbert, see Baissac, M. K. de
Hercule, see Dubois
 HERMIT, F cct, 304, 336, 356, 467
 Herriot, E., 157, 190, 201, 232, 277
 Heritier, R., 373
Hervieux, see Huet
 Heslop, R. H., DSO: (1), 178, 199, 261; (2), 50, 87, 257; (3), 87, 257, 276, 310, 314–15; (4), 43, 127, 328, 354, 362, 371
 Hessel, S., 375
 Heydrich, R., 381
Hilaire, see Starr, G. R.
 HILLBLIX, F cct, 234, 357, 467
 Hiller, G. F., DSO, 333–4
 Himmler, H., 107–9, 286, 306, 310, 373, 376, 381
 Hinton, N., 171
 Hippocratic oath, 328, 346, 375
 HISTORIAN, F cct, 360, 416, 467
History, of SOE sections, 397; cited *passim*
 Hitler, A. xi, xxiii, 3, 106–9, 110, 122, 132, 184, 198, 276, 310, 381, 386, 438, 471; personal interest in SOE, 132, 168–70, 274, 306–7, 373; plot against, of 20 July, 107, 364, 373, 471
 Hoare, Sir S. J. G. (Lord Templewood), GCSI, GBE, CMG, 88, 405, 480n154
 Hobbes, T., 122
 Hogg, Q. McG., 20
 Holdsworth, G., DSO, 62–3, 152
 Holland, see Netherlands
 Holland, J. C. F., CB, DFC, founder of SOE, 4–12, 380, 381
 Hollis, Sir L. C., KBE, CB, 405
Holmes, Sherlock, 14
 Holst, W., 143
Honoré, see Barrett
 Hostache, R., 405; cited, 26, 127–8, 366, 482n40, 484n79
 hostages, 136
 HOUNDSORTH, SAS party, 355–6
 HOUSEKEEPER, abortive F raid, 224
 Houseman, J. B., MBE, 52, 344–5, 346
 Housman, A. E., 295
 Houston-Boswall, (Sir) W. E., CMG, MC, 27
 Howard, M. E., MC, 405, 484n53
 Hubble, D. E., 28, 354
Hubert, see Bardanne; Kawalkowski
 Hudson, C. S., DSO: (1), 194; escape, 332; (2), 336, 350
 Hudsons, see pick-ups, air
 Hue, A. H., DSO, 234, 357
 Huet, 345–6
 HUGH JEDBURGH, 356
Humanité, l', see press
 Humphreys, L., OBE, 21, 46, 49, 91–2, 140, 142, 161–2, 225, 470
 Hutchison, (Sir) J. R. H., DSO, TD: as RF, 22, 49, 208, 216, 316, 397, 470; as agent, 339, 355–6
 Hymans, Max, 148, 156
 Hytier, A., 60, 405
Ignace, see Gaillot
 III F, Abwehr branch, 108
 Inayat Khan, N., GC, MBE, 297–8, 408; training, 298; to France, 261, 415; in France, 270, 279, 280–1, 286, 287, 298–302; arrest, 298–301; escape, 295, 300, 320; set played back, 301–6; chained, 376, 378; killed, 377
 Indre, 342, see also WRESTLER
 Information, Ministry of, 11, 18
 intelligence: military, ix, xxiii, 123, 130–1, 136, 139, 152, 236, 356, 382, 439; service, 8, 24, 63–4, 97, 130–1, 141, 150, 159, 206–7, 242, 255, 310, 313, 359, 380–1
 INTERALLIÉ, intelligence cct, 131, 159, 172, 174, 201
 interdepartmental warfare, see rivalries
 Interior, French ministry of, 109
 Interior, gaullist commissariat of, 23, 207
 international law, xxii, 169, 426
 INVENTOR, F cct, 195, 261, 264, 324, 415, 466–7
 Inverlair, 57
 Inverness, 53
 Ireland, 4–5, 6, 20, 125, 194
 ISAAC mission, see VERVEINE
Isabelle, see Lavigne
 Isère, 314, 315, 347
 Ismay, Sir H. L. (lord), GCB, CH, DSO, 30, 150, 313
 ISOTROPE, mission, 354
 ISRB, 13, 40
 Issy-les-Moulineaux, Seine, 90
 Italians in France, xxn, 229
 Italy, 119, 125, 229, 247, 340, 468, 470
 itching powder, see weapons
 IV F, SD branch, 109–10, see also security forces, German
 IVOR JEDBURGH, 76
Jacky, 264
Jacqueline, see Nearne, J.; Rudellat

- Jacquelot, 289
Jacques, see Planel
 Janyk, C., 331, 373
 Japan, 248, 470, 471
 Jaurès, J., 332
Jean, see Jestin
Jeanette, see Sicot
 Jebb, G. (lord Gladwyn), CMG, 9, 18–19, 137, 140, 150
 JEDBURGH teams: 345, 396, 420; objects, 33, 122; operations, 33, 134, 344, 351–5, 357, 421, 471; training, 323–4, 480n162
 Jefferys, Sir M. R., KBE, MC, 5
 JELLYFISH, pick-up, 205
 Jepson, S., 42–3, 47
Jérôme, see Brault, M.
 Jestin, A., 70
 Jews, 16; in SOE, 50, 98, 170, 187, 197
 JIC, 303–4
 Jickell, A. W., 191, 255
 JOCKEY, F cct, 77–8, 127, 243, 247, 330–1, 342, 362–3, 415, 417, 467
 Jodl, A., 169
Joew, see Kergorlay
 Johnson, D., 87
 Jones, G. D., MC, 253–4
 Jones, S. C., 194–5, 261, 264, 325, 450–1
Joseph, 219, see also Aron, J. M.
 JOSEPHINE, RF raid, 144–5
 Jouan, E., 70
 Jouhaux, L., 161, 189, 197, 438
 JPS, 150–1
 JUDEX missions, 45, 372, 396; F report, cited, 481n199
 JUGGLER, F cct, 230–1, 275, 282–3, 331, 376, 466–7
Julien, see Newman
 Jullian, G., 417
 Jumeau, C., 76, 183
 Jura, 92, 133, 257, 328, 431
Justin, see Cohen; Kawalkowski; Rake
 Kaltenbrunner, E., 377
 Kapri, A. von, 294
 Karlsruhe, 378
 Kawalkowski, 142
 Keitel, W., 168–9
 Kergorlay, comte A. de, 152, 161, 201–2, 373
Khodja, see *Chaland*
 Kieffer, H. J., SD leader, 109–10, 259, 270–1, 277, 281–2, 300–1, 356, 367, 378, 379
 Kieffer or Kiffer, J. L., double agent, 244, 259, 326, 367
 Kijakowski, see Bitner
Kim, see Schmidt
 Kipling, R., cited, 26, 131, 480n136
 Kleberg, general, 170
 KNACKER, pick-up, 265, 267
 Knight, M. D. F., 326–7, 417
 Knochen, H., 109
 Koenig, P.-J., xxiv, 32, 126, 318, 337, 339, 341, 365
 Kogon, E., 375, 487n56
 Kot, professor, 25
 Krajewski, H., DSO, 65
Kriegel, see Valrimont
 Labaloue, M., 89
 Labit, H.: (1), 151, 195; (2), 202, 409
 Labour, organized French, 161
 LABOURER, abortive F cct, 335–6, 417, 467
 LACKEY, abortive F cct, 265, 329–30, 467
 LAFITTE, abortive sea pick-ups, 66, 185
 Lafont, see Bony-Lafont
 Lagier, R., MBE, 23, 139, 144, 145
 Lake, P., 333
Lancel, see Gianello
 Landes, R. MC, 180, 204, 250, 333, 360, 369–70, 402, 478n54, 478n85
 Langard, E., 70–1
 Langelaan, G., 54, 96, 156–7, 183, 234, 405, 480n150
 Langer, W. L., 405
 La Pallice, 248
 Lapierre, D., see Collins
 Larcher, G. L., 224
 Larcher, M. L. M. A., 359
 Lardy, R., 205
 Larminat, general de, 125
 La Rochelle, 171, 421
 Lassen, A. VC, 168
 Latour, J., 225, 331
 Latour, P. A., 417
 Latre de Tassigny, J. de, MC, 125, 183, 206, 222, 363, 371
Laurent, see Steele
 Laurent, M., 280
 Laval, P., 125, 131, 252, 367, 441, 442
 Laverdet, 152, 205
 Lavigne, M., 260, 417
 Law, R. K. (Lord Coleraine), 317
 Lawrence, T. E., 3–4, 9, 476n45
 leadership, 257, 349
 leaflets, 79
 Leahy, W. D., 405
 Leccia, M., 335
 Le Chêne, H. P., 190–1, 254–5
 Le Chêne, M.-T., 191, 262, 414
 Le Chêne, P. L., MBE, 191, 373
 Le Creusot, 222
Leclerc, J. P., 125, 364, 365
 Lecorvaisier, L., 70–1, 90, 476n35
 Ledoux, G. E., 302, 373
 Ledoux, J. P. H., 302
 Lee, L., MC, 291; betrayed, 83, 302–7
 Lee Graham, L., 76
 Lefort, C. M., 68, 228, 229, 261, 377, 415
 Legentilhomme, P. L., 125
 Le Harivel, J. P., 156, 183, 303
 Le Havre, 108, 136, 234, 243
 Leigh, V., 261, 264, 376, 415, 450
 Lejeune, P. H. A., 260, 261, 275, 280
 Le Mans, 156, 158, 160, 175, 260, 299, 303
Lemniscaete, see Rondenay
 Lencement, R., 152, 373
 Lenin, see Ulyanov
 Lenormand, 219
Leopold, see Rousset
 Lepage, M., 293, 307
 Leproux, M., 405; cited, 6, 424, 479n120
 Le Puy, 192
 Lequex, M., 284
Leroy, see Labit
 Leroy, R.: (1), 156, 158, 161, 175; (2), 180
 Lesage, J. E., 265, 329–30
 Lesout, E., 293, 307

- Letac, Joel, 141, 144–5, 152, 161, 166, 201–2, 373
 Letac, Mme, 152
 Letac, Yves, 144, 152, 201–2, 373
 lethal tablets, *see* weapons
 ‘letter-boxes’, 89–90, 148, 202–3, 280, 449–52
 Levene, E., 263
 Levêque, Mme, 289
 leverage, military, 4, 15, 135, 383–4
 Leverkusen, P., 405
 Levin, G., 28, 91, 170, 289
 Levy, Dr, 154, 158, 183–4, 187
 L’Herminier, 66
 LIBÉRATION, movement, 151, 163, 203, 206, 438–76
 LIBÉRATION NATIONALE, movement, 163, 202, 438–76
 LIBÉRATION-NORD, movement, 214
 LIBERTÉ, movement, 151, 163, 202, 441
 LICENSEE, F cct, 467
 Liddell Hart, (Sir) B. H., 15, 349
 Liewer, P. MC, 154, 156, 183; (1), 234–6, 260–2, 264; (2), 100, 336; (3), 360, 363, 482n39
 Lille: F and, 178, 200, 237–8, 243–4, 256, 342, 352; Poles round, 142, 237, 324, 352
 Limoges, 149, 174, 178, 180, 182–3, 342, 350, 351, 353, 360, 363
 Lindell, M., 377
 Lionel, *see* Benoist, R.
 LIONTAMER, abortive F cct, 293, 297, 305, 307, 467
 Lisbon, 68, 142, 163, 283, 452
 Lise, *see* Sansom
 Livry-Level, P., 405, 409
 LLL, 438–46
 Lloyd, G. C. L. lord, GCSI, GCBE, DSO, 9, 156
 LMGs, *see* weapons, Bren
 lock-picking, 56
 Lockhart, Sir R. B., KCMG, 11
 Lodwick, J. A. P., 171, 405, 480n148; cited, 46
 Loire, river, 132, 237, 260, 277, 279, 327, 336, 350, 356, 447
 London Group, 20, *see also* AD/E
 Longe, D., MC, 52, 344–6
 Lons-le-Saunier, Jura, 361, 431
 Lorient, 242–3, 357, 370
 Lorraine, 293, 307, 325, 343, 355–6, 438
 Lot, 189, 333–4
 Louba, *see* Frager
 Loupias, 401
 Lovinfosse, G. A. T. Y., MBE, 224
 LOYOLA, DF line, 323
 Lucas, *see* Vonécourt, Pierre de
 Lucien, *see* Bizot
 luck, vital, 61, 68, 113, 153, 181, 242, 350, 361, 375
 Lyon, R. MBE, 154, 157, 255, 261, 329, 482n39
 Lyons: 108, 146; DF and, 89, 94, 143, 289–90, 321; F and, 147, 158, 182–3, 189–94, 196–7, 246–7, 255, 329–30, 362, 371, 386; RF and, 203, 308, 315, 319, 322, 330, 344, 381, 428
 Lysanders, 83, *see also* pick-up operations
 M, 21, 24, *see also* Gubbins
 Macalister, J. K., 279, 281, 290, 293, 294, 299, 307
 McBain, G. B., 293, 307
 Mack, W. H. B., CMG, 312
 Mackenzie, K. Y. M., MC, 327
 Mackenzie, W. J. M., 27–8, 408
 Maclean, (Sir) F. H., CBE, 476n52
 MacLeod, (Sir) R. W., CBE, DSO, 324, 358
 McLuskey, J. F., MC, 407
 Macmillan, H., x, xxi, 311
 Madagascar, 200, 204, 207
 Madeleine, *see* Inayat Khan
 Mahée, Dr, 240
 mail, *see* communications, SOE’s, air mail
 Maingard, R. A. L. P., DSO, 255, 335, 342, 350, 386
 MAINMAST, RF cct, 151, 202
 Maitland Wilson, Sir H. (lord), GCB, CBE, DSO, 388
 Makgill, Sir J. D. A., 48
 Malfettes, M., 478n76
 Maloubier, R. MC., 234, 264
 Malraux, A., 251, 363, 411
 Malraux, C., 100, 234
 Malraux, R., 252, 333
 Malval, baron A. de, 187, 226, 372
 Manchester, 56, 75, 191, 255
 Mangin, L., 216, 319
 MANGO, DF line, 64, 68
 Manuel, P. E. J., 24
 Maquis: role, 315, 319, 327–9, 337, 344–9, 361–2, 363, 370, 426; what, xxi, 252–3, 316; supply, 312–14, 327, 424–6; *service*, 312, 314–15
 Marc, *see* Clement, M. R.
 Marcel, *see* Agazarian, J. C. A.
 March-Phillips, G. H., DSO, MC, MBE, 167–8, 374
 Marchand, J. DSO., 193, 255, 262, 329
 Marcilly, C. de, 418
 Marguerite, *see* Agazarian, F.; Baissac, L. de
 Marie, *see* Basset, R.; Hall; Witherington
 MARIE-CLAIRE, RF mission, 215–21, 320, 412
 Marienne, H., 357
 Marin, L., 146
 Marion, D., 50
 Marks, L., 98, 216, 306, 407
 MARKSMAN, F cct, 87, 127, 133, 257, 329, 371, 416, 466–7
 Marne, 359
 Marquis, *see* Rivière, P.
 Marriott, H. R.: head of F, 21, 143, 147, 470; dismissed, 162
 Marsac, A., 184, 187, 225, 227
 Marseilles: 163; DF and, 143; F and, 155, 157–8, 180, 183, 184, 192, 194–7, 260, 330–2, 342, 368, 386, 440, 500n91
 Marshall, B., 407; cited, 28, 30
 Marshall, G. N., 159, 236
 Martelli, G., 94–5, 407
 Marten, H., 345
 Martinot, P. M., 331, 374
 Masaryk, T. G., 119
 MASON, F cct, 193, 329, 467
 Massenet, P., 229
 MASSINGHAM, SOE base, 31–2, 57–8, 77–8, 345, 353, 396, 420
 Masuy, *see* Delfanne
 Mattei, P., 374
 Maugenet, A. A., 263–4
 Maurienne, Savoie, 181, 347
 Mauritians, 179, 201, 334
 Maury, G., 325
 Mauzac, Dordogne, 183, 231, 321, 461
 Max, *see* Garel; Moulin
 Maxime, *see* Hiller
 Maximence, *see* Hymans
 Mayer, D., 334

- Mayer, E. P., MBE, 334, 363
 Mayer, J. A., 334
 Mayer, P. E., OBE, MC, 334, 350, 363
 Mayhew, C. P., 17
 Mayne, R. B., DSO, 381
 Meaux, Seine-et-Marne, 283–4
 medical services, in Maquis, 327–8
 Medmenham, Buckinghamshire, 86
 MENACE, gaullist raid, *see* Dakar
 Menesson, J. F. G., 190, 263
 Menthon, F. de, 151
 Meric, Dr, 244
 Méridnac, Gironde, 144, 152, 205
 Mers-el-Kebir, Oran, 120–1, 123, 136, 468
Mesnard, *see* Meunier
 Métro, 111–12, 217–18, 280
 Meunier, J., 229
 MEW, 17, 39–40, 149, 382
Michel, *see* Churchill, P. M.; Rafferty
 Michel, F., 293
 Michel, H. J., 25, 398, 402, 407; cited, 25, 66, 110, 120, 293, 407, 474n52, 482n13, 482n15, 497n3, 498n20
 Michelin, 257
Mickey, *see* Dumont-Guillemet
Miklos, *see* Brault, M.
 Milice, *see* security forces, French
 Millar, G. R., DSO, MC, 52, 92, 327; dropped, 337, 342, 399; cited, 41–2, 46, 50, 110, 327, 407, 476n52, 479n109, 479n126
Mimi, *see* Fontaine
 Minerault, E., 71
 MINISTER, F cct, 325, 416, 467
 Minney, R. J., 407–8, 479n120; cited, 475n7, 475n29, 475n63, 476n46
 Minshall, M. T., 138
 MI R, formerly GS(R), xvii, 5–12, 29, 52, 136–7, 141, 202, 380, 468
 Miksche, F. O., 478n57
Missions interalliées: 319, 344, 351–2, 353, 371; table, 354
 mistakes, *see* errors
 Mitterrand, J. A. A., 91, 170
 MMLA, 367
 MO section, 20, 22, 74
 MO I(SP), 13, 40
 MO 4, Cairo, 4
 Moch, A., 247, 329
 Moch, J., 246, 390–1
 Mockers, M., 408, 500n98
 Mockler-Ferryman, E. E., CB, CBE, MC, 20, 49, 265, 268, 312, 334, 387
 MO/D, *see* RF section
 Molotov, V. M., xxiii, 31
 money, *see* currency; finance
 MONICA, EU/P cct, 237, 323, 352
Monique, *see* Borrel
 Monjaret, H., 202
 MONK, F cct, 229, 261, 330–2, 415, 467
 MONKEYPUZZLE, F cct, 177, 201, 466–7
 Monnier, C. F., 315, 354
 Montagne noire, Tarn, 361
 MONTAGNE NOIRE, CORPS FRANCE DE LA, 332
 Montague, E. E. S., OBE, 274
 Montalembert, Comte A. de, 284
 Montauban, Tarn-et-Garonne, 196, 350
 Montaut, J. L., 205
 Montbéliard, Doubs, 256
 Montceau-les-mines, Saône et Loire, 177
 Montgomery, Sir B. L. Viscount, KG, GCB, DSO, 361, 362, 371, 388, 470
 Montluçon, 335, 385
 Montmartre, 179
 Montmouchet, Aveyron, 358
 Monzie, A. de, 442
 Moon, 61, 69, 81, 261
 Morandat, L. Y., OBE, 153, 162, 196, 205–6, 246
 Morandat, R., 196, 246–7
 Morel, G., MBE, 100, 155–6, 161, 192, 265, 268–9, 294, 304, 306, 337, 354, 371
 Morel, T., 328, 371
 Morgan, Sir F. E., KCB, 212
 Morocco, 311, 328, *see also* TORCH
 Mortimore, L. H., MBE, 142
 Morton, Sir D. J. F., KCB, CMG, MC, 9, 207, 311, 312
 Moulin, J., 109, 114, 151, 162–5, 202–3, 205–8, 213–16, 218, 253, 310, 364, 408, 420, 470; report, 1941, 437–46; beaten to death, 215, 308; greatness of, 164–5, 308
 Mountbatten, Lord L. (F.A.V.N.) (earl), KG, GCVO, KCB, DSO, 29, 165–9, 371
 MOUNTEBANK, abortive sea pick-up, 159
 Mulsant, P., 240, 243, 263, 325–6, 360, 375
 Munich agreement, 123, 468
 Murat, prince, 123
 murder, *see* assassination
 Murphy, R., 389
 Murray, M. P., 19
 MUSC mission, 354
 MUSICIAN, F cct, 200, 237, 240, 324, 361, 415, 466–7
Mussel, *see* Deshayes
 Mussolini, B., GCB, 110, 119
 Mynatt, C. F., 76, 353
Myrtil, *see* Unienville
 N section, 56, 277–9, 289, 334
Nadine, *see* Rolfe
 Nantes, 108, 161, 279, 336, 447–50
 NAP, 369
Napoleon, *see* Massenet
 Napoleon I, 122, 123, 129, 502n75
Narcisse, *see* Bouchardon
 nationality, in SOE, 255, 429
 Navy: British, 430; French, 199; German, 135, 154, 166, 223–4, *see also* ships
 Nazism, xxi, 106–9, 124–5, *see also* atrocities; concentration camps
 Nearne, E., MBE, 325, 359, 374, 377, 378, 416
 Nearne, J., MBE, 253, 298, 325, 415
Necker, *see* Bingen
 Nelson, Sir F., KCMG, 18, 19, 43, 49, 102, 137, 162, 470
 NEPTUNE, landing, 103, 168, 308, 309–10, 313, 337, 340–6, 350, 359, 362, 367, 386, 388, 410, 423, 448; Germans knew imminent, 341–2
 Nesbitt-Dufort, J., DSO, 155
Nestor, *see* Poirier
 Netherlands, 7, 56, 60, 101, 277–8, 289, 304, 468, *see also* NORTH POLE
 Nevers, 141, 327, 355
 Newman, I: (1), 187; (2), 234, 261

- NEWSAGENT, F cct, 193, 255, 262, 329, 467
 Newton, A. A. G., MBE, and H. G., MBE, 192, 254–5;
 cited, 374
 next of kin, messages to, 43–5
Nicholas, see Boiteux
 Nicholas, E., 43, 229, 330–1, 408, 499n57
 NID (Q), 13
 Nietzsche, F. W., 49
 NKVD, 31, 397
Noël, see Bouchard
 Noguès, C. A. A. P., 125
 Nord, 107, see also FARMER
 NORDPOL, see NORTH POLE
 Norgeby House, Baker Street, 40, 500n96
 Norman, H. G.: dropped, 179, 204; at work, 270–1,
 275–6, 278, 285; arrested, 280–1, 299;
 interrogated, 281–6, 288, 291, 331; kept to
 intimidate others, 295, 296; his set played back by
 Germans, 286, 291–3, 304; executed, 295, 307
 Normandy, 151, 153, 174–6, 224, 280, 307, 326, 331,
 336, 340–1, 349–50, 354, 361–2, 386, 423,
 502n79
 NORTH POLE, German deception of N section: origins,
 101, 277, 334, 404; and DF section, 289–91; and
 F section, 277–9, 285, 303–4
 Norway, 7, 22, 120, 135, 468
Now it can be told, see film
 Nuremberg: air raid on, 311; trial, 108, 169, 408
 NURSE, WT plan, 306
- oaths, 325
 OCM, 133, 240, 249, 251, 287, 401
Octave, see Chantraine
Odette, see Baseden; Sansom
Odile, see Baissac, L. de
 officers, high proportion in SOE, 16
 OGS, 33, 132, 344–5, 346, 352, 353
 O’Lcary, see Guérisse
Olive, see Basin
Olivier, F agent, 232, 237–9
 Olschansky, S., 283, 376
 one-time pads, 98, see also cipher
 O’Neil, M., 249–50, 251, 287
 ORA, 212
 Orabona, 75
 Oradour, Haute Vienne, 351, 362
 Oran, 120–1, 123, 136
 ORATOR, abortive F cct, 258, 302, 306, 467
 Orchard Court, Portman Square, 40, 114
 organizers, SOE’s, tasks of, xxii, 52, 126–7, 162
 Orleans, 260, 297, 337, 350, 360, 386, 432
 ORONTE, RF cct, 418
 Ortiz, P. J., 315, 347, 354
Oscar, see Valéc
 OSS, 16, 31–2, 331, 353, see also OGS
 O’Sullivan, M. P., MBE, 334, 416
 OUTCLASS, RF cct, 153, 196, 246
 OVERCLOUD, RF cct and line, 65, 131, 151–2, 186, 201,
 243, 303
 OVERLORD, invasion, xxiv–xxv, 77, 103, 133, 135,
 173–4, 302, 304, 307, 309–10, 313, 316, 321, 336,
 339–44, 346–65, 367, 386–7, 409, 423, 448, 471
 Overton Fuller, J., 408; cited, 499n44
 OVRA, see Italians
 Oxford, 48, 66, 130, 194, 233, 403
Oyster, see Pichard
- Pacha*, see Guillermin
 packages, 76–8, 423
 Paimblanc, J., 205
Paquebot, see Pellay
 parachuting: accidents, 75–6, 153, 159, 171, 196, 200,
 330, 353; of men, 60, 71, 74–6, 138–371; refusals,
 138; of stores, 76–9, see also supply; air
 Pardi, P. B., 263
 Paris, see also vic: 243; DF and, 289; F and, 149, 158,
 171, 177, 237–8, 247, 249, 254, 260, 267, 272–3,
 286, 299, 308, 312, 324–5, 326, 330, 342, 349,
 354, 361, 364, 367, 448, 450–1; PCF and, 325;
 RF and, 217–18; rising in, 364–6, 402, 411;
 welcomes de Gaulle, 365–7, 471
 Parisot, M., 87
 Parke, C. J., cited, 500n79
 Parker, G. E., DSO, 328
 Parliament, British, x, 10, 11, 17, 18, 337; debates,
 cited, x, 48
 Parodi, A., 320, 364–6
Parsifal, see Parker
 PARSIFAL, intelligence cct, 221
 PARSON, F cct, 233–4, 264, 303, 357, 467
 Pas-de-Calais, 107, 310
 passwords, 105, 278, 451
Passy, see Dewavrin: cited, 96, 97, 126, 498n20; his
Souvenirs, 408
 Pasty, abbé E., 284
 PAT, escape line, 259, 276, 376
 Patch, A., 363
Patrice, see Sheppard
 Patton, G. S., 362, 363, 371
Paul, see Cauchi, J. M.; Cole; Frager; Le Chêne, H. P.;
 Poitras
Paulette, see Rowden
Pauline, see Granville
 PAVOT mission, 354, 371
 pay, 46
 PCF, see Communist party, French
 Pearson, D. M., MBE, 307
 Peclat, 289
 Pecquet, A. E., 345, 346
 PEDAGOGUE, F cct, 307, 467
 PEDLAR, F cct, 359, 467
Pedro, see Cauchi, E. J.
 Pellay, M., MC, 223, 374
Pepe, see Newman, I
Perch, see Fassin
 Pergolèse, rue, Paris 16e, 260, 283
 Périgueux, 156, 183, 350
 PÉRIMÈTRE, RF cct, 418
 PERTOINE, RF cct, 418
 PERMIT, F cct, 30, 417, 467
 Perpignan, 93–4, 102, 142, 157, 170, 200, 255, 289
 Perrault, G., 409
 Perry, 76
 Pertschuk, M., 190, 195–6, 245–6
 Pessac, Gironde, 144–5, 160
 Pétain, H. P., xxi, 60, 120, 121–8, 198, 206, 212–13,
 276, 367, 390, 440, 441–4, 468
 Petitjean, M., 418
 Peugeot family, 257, 385, 454
 Peulevé, H. L. T. A., DSO: (1), 76, 179, 251; (2), 100,
 127, 251–2, 262; arrest, 333; in prison, 114–15,
 350, 374; final escape, 375;
 Pforzheim, 376, 378

- PHANTOM (signals) squadron, with SAS, 324, 358
 Philip, A., 23, 207
 Phillips, Sir T. S. V., KCB, 150
 PHONO, F cct, 258, 287, 290, 297–303, 305, 306, 415, 466–7
 PHYSICIAN, F cct, *see* PROSPER
 Pichard, G., 217–18, 267
 Pickersgill, F. H., 279, 281, 293–4, 307, 325
 pick-up operations, air: drill, 86–7, 427–36; feasibility, 60, 87, 221; rate, 83–5, 265–8
 specific: by Dakota, 83, 85, 353, 356; by Hudson, 87, 195, 206, 215, 222, 236, 243, 247, 257, 262–5, 268, 284, 311; by Lysander, 165–331 *passim*, 415–17; by Lysander, abortive, 181, 206, 207, 272–3, 299
 pick-up operations, sea, *see* feluccas; submarines
Pierre, 100, *see also* Zembsch-Schreve
 PIERRE-JACQUES, DF line, 113, 224, 323
 Pierre, J., 345
 Pict, J., 153
 PILCHARD, RF raid, 204
 PIMENTO, F cct, 102, 127, 133–4, 194, 196–7, 229–30, 243, 246–7, 247, 255, 304, 329–30, 342, 350, 362, 386, 466–7, 470
Pinasse, *see* Bohec
 Piquet-Wicks, E., 22, 49, 144, 164–5, 409; cited, 75, 152, 164–5, 470, 499n28
 Placke, J., 115, 272, 276, 278, 293, 296, 325
 PLANE, F cct, 254, 414, 466–7
 Planel, J. M. C., MC, 224
 planning: by gaullists, 315–16, 443–5; in SOE, 20, 341
 plastic explosive, *see* sabotage; weapons
 Plewman, E. S., 229, 255, 262, 415; arrested, 330–1, 378; killed, 377
 Plymouth, 69
 POINTBLANK, air raids, 212, 256–7, 311, 313
 Poirier, J. R. E., DSO, 127, 333
 Poitiers, Poitou, 112, 180, 182, 201, 248, 254, 260, 350
 Poitras, E. W., MC, 327
 Poland, 6, 42, 119, 323, 468, 471
 Poles, 5, 7, 144, 237, 262, 368, 371–2, 375, *see also* EU/P; ships, HM, feluccas
 police, *see* security forces
 political warfare, 124–5, 349, 389, 438–43, *see also* PWE
Polygone, *see* Bourguès-Maunoury
 Popiel, K., 323
 Port-en-Bessin, Calvados, 168, 340
 Portal, Sir C. F. A. (lord), KG, GCB, OM, DSO, MC, 15, 71–2, 137, 140, 150, 211, 311–13
 post, *see* communications, SOE's
 Poudrebaq, J., 264
 Pound, Sir D., GCB, OM, GCVO, 137
 Pownall, Sir H. R., KCB, KBE, DSO, MC, 5, 150
 Prendergast, G. L., 354, 371
 Press
 British, popular, 48; *The Times*, 502n4, 503n14, 504n43, 505n28, 510n175, 512n36
 clandestine, 77, 170; *Coq Enchaîné*, 190; *Humanité*, 124, 146; *Petites Ailes*, 146; *Vérité*, 438–9
 French, 48, 259
 PRIEST, abortive F cct, 258, 293, 305, 467
 priests, 124, 161, 284
Prise de pouvoir, *see* civil power
Prisme, *see* Bolladière
 prisoners, how Germans treated: French civil, 373; SAS, 355; SOE, 151, 158, 284–6, 360, 373–9
- PRIVET, F cct, 177–8, 199, 231, 233, 279, 466–7
 PROFESSOR, F cct, 466–7
 propaganda, *see* political warfare
Prosper, *see* Suttill
 PROSPER, F cct: launched, 179, 414, 415, 470; range, 127, 132, 133, 134, 179, 231, 234, 240, 244, 249, 261, 332, 364, 466–7; security, 51, 105, 275–7, 283–4, 307, 330; collapse, 209, 230, 237–8, 249–50, 258–9, 261–2, 273–86, 290, 310, 324, 405, 408, 470
 Proust, M., 14, 252
 Provence, 163, 165, 203, 245, 251, 330–2, 363
 PRUNUS, F cct, 195–6, 245, 466–7
 PUBLICAN, F cct, 283–4, 467
 punctuality, 89, *see also* rendezvous
 Puy, Comte J. P. M. du, 156–7, 373
 Puy-de-Dôme, 254
 PWE, xx, 11–12, 137, 187, 190, 195, 198, 323, 349
 Pyrenees, 252, 289; agents cross, *passim*; how to cross, 92–4, 290
- QUADRANT conference, 212
Quartus, *see* Parodi
 Quimper, 70
- Rabinovich, A., MC: (1), 187, 189, 197, 226, 227, 245, 379; (2), 291, 294, 307
 Racheline, L., 170, 183, 320–1, 502n80
 Rachtet, *see* Racheline
 RACKETEER, F cct, 336, 467
 radar, 63, 80, 166, *see also* *Eureka*
 radio, *see* wireless
 Radio Alger, 197
 Radio Paris, 204, 297
Radio Patrie, 186
 RAF: 127, 235, 328, 351, 372, 374, 383–4, *see also* Air Ministry; aircraft, British; supply, air; WAAF; 3 (Bomber) Group, 72; 38 (Transport) Group, 311, 355; indispensable to resistance, 127, 146–7, 363, 389, 445; officers in SOE, 43, 177
 RAF, Bomber Command, 150, 256–7, 309, 311–14, 325, 341, 412; compared with SOE, xxii, 15, 156, 256–7, 382–5
 RAF, Squadrons: *138*, 73–4, 155, 247, 389, 398, 411, *see also* supply, air; *148*, 498n8; *161*, 45, 83, 205, 260–7, 389, 398, 406, *see also* pick-ups; *418*(RCAF), 78, 302; *426*, 498n8; *617*, 383; 419 Flight, 73; 1419 Flight, 73
 Rafferty, B. D., 194, 253–4
 railways, 141, 145, 151, 158, 161, 175, 177, 182, 184, 189, 195–7, 237, 319, 344, 361, *see also* derailments
 Rake, D., MC: (1), 177–8, 199–200; (2), 322, 327
 rank, unimportant, xi, 43
 Rankin, invasion plan, 310
Raoul, *see* Churchill, P. M.
 Rapin, A., 205
 Ratier, A., *see* Antelme
 Ratier, factory, 333–4, 455
 rationing, food, 88, 91, 106, 121, 125, 245, 283, 333
 RATWEEK, SOE raids, 322, 330, 381
Raymond, *see* Minerault
 Raynaud, P. J. L., DSO, 228–9, 331
Rebecca, 81

- reception committees: for parachute drops, 79–80, 82–3, 102, 293, 355; for pick-ups, 86–7, 434, 449, 451; for sea landings, 70, 189, 420–1
- Rechenmann, C., 243, 263, 332
- recruiting, *see* agents
- RECTANGLE, RF cct, 418
- Redding, G. C. B., 173–4, 373
- Rée, H. A., DSO, OBE, 255–6, 276, 310, 327, 384, 402
- Régis, Mme, 330–1
- Regnier, J., 193, 262
- Reich, Das*, panzer division, *see* Waffen-SS
- Reile, A., 270
- Reitlinger, G., 409
- Rémy*, *see* Renault-Roulier
- Renan, M., 148, 153
- Renaud*, *see* Antelme
- Renault-Roulier, G., 139, 409
- rendezvous, 89, 103–5, 196–7, 241, 264, 280
- Rennes, 68–71, 152, 320, 356, 358
- reprisals, 14, 160–1, 329, 386
- Resistance, xxi, 30–1, 161, 163, 210, 319, 363, 386, 396, 407; external v. internal, 132, 220, 318, 364–5; unity attempted, 30–1, 165, 206–8, 213–22
- revolution, 119, 160, 163, 199, 357, 364, 367, 370, 385, 446, 471
- Revue d'histoire de la deuxième guerre mondiale*, 410
- Rewez, *see* Robert, J.
- Rex*, *see* Moulin
- Reynaud, P., 120, 190, 328, 410
- RF sections: 111, 221, 396, 453; origins, xxii, 22, 144; objects, xxii, 22; operations, 406; operations, 1941, tentative, 144–6, 151–2, 190–1; operations, 1942, various, 201–8; operations, 1943, various, 209–11, 213–24, 288; operations, 1944, successful, 25, 318–22, 326–7, 353; merged with EMFFI, 25, 32, 130, 339; relations with BCRA, 23–6, 207, 215–17, 364; relations with F, *see* rivalries, inter-section; staff, 22, 207, 215–16; winding up, 45
- Rheam, G. T. T., OBE, 56, 191, 238, 384
- Rhone valley, 163, 243, 312–13, 330–2, 342, 354, 363, 368
- Ribbentrop, J. von, xxiii, 31
- Richards, (Sir) F. B., DSC, 32, 388
- Rigoulet, A., 183
- rivalries: inter-departmental, 7, 8–9, 11, 136–7, 209–10; inter-section, xxii, 23, 105, 131–2, 177, 288, 319, 337–9; inter-service, xxii, 33, 64, 151, 235–6, 260, 264
- Riviera, 61, 65–6, 154, 157–8, 170, 184, 186–9, 194–7, 226, 245, 326, 362
- Rivière, P., OBE, MM, 203, 266, 273
- Rizzo, E. V. H., OBE, and G., 142
- Roach*, *see* Ayril
- Robert*, *see* Bertholet
- Robert, J., DSO, OBE, 318, 347–8, 354, 371
- Robin*, *see* Weil; Worms
- Roche, R. B., 157, 183
- Rochefoucauld, Comtesse Y. de la, 283
- Rochester, D. 87, 416
- Rod*, *see* Deshayes
- Rodolphe*, *see* Sevenet
- Roger*, *see* Bardet; Cammaerts
- Rol*, *see* Tanguy
- Roland*, *see* Rivière, P.
- Rolfé, L. V., 360, 377, 416
- Roman Catholic Church: country priests, 124, 161; episcopate, 124
- Rommel, E., 342
- Rondenay, A. L., shot, 319
- Roosevelt, F. D., xxiii, 120, 198, 212, 389, 404, 438
- Rose*, *see* Nearne, E.
- Rosenthal, J. P., MC, 87, 257, 315, 329
- Rossi, A.*, 410
- Rouen, 7, 100, 234–6, 336
- Rouneau, M. H., MBE, 336
- Rousset, M. J. L., MC, 231, 233, 283, 296–7, 303, 307, 389
- ROVER, F cct, 332, 467
- Rowden, D. H., MBE, 44, 255, 261, 263–4, 279, 302, 376, 415
- Rowlandson, M., 344
- R/T, 435
- Rudellat, Y. C., 178, 179, 229, 279, 281, 377, 379, 414
- rumour, 177, 365
- Rundstedt, G. von, 201, 209, 254, 271, 314
- Russia, 6, 350, *see also* USSR
- Russian front, *see* war, 1939–45
- Sables d'Olonne, Les, 141, 421
- sabotage: handbook, 6; industrial, 381–2, 382–3, 384; industrial, results, 453–5; methods, 5, 166, 195; operations, 144–5, 154, 160, 178, 328, 333–4, 385, *see also* RAF Bomber Command, comparison; targets; strategic purposes, 14, 130–1, 150–1, 164, 210, 439; training in France, 162, 191; training in UK, 55–6; undetectable, 29, 199
- Sabourin, R., 293–4, 303, 307, 503n19
- SACRISTAN, F cct, 232–3, 327, 467
- safe houses, 88–92
- safe-breaking, 56
- SAINFOIN mission, 354, 371
- SAINT, F cct, 134, 416, 467
- St Cast, Côtes-du-Nord, 68
- St Ermin's hotel, Westminster, 40
- St Etienne, 153, 191
- St Geniès, baron M. J. Gonzagues de, 330, 360–1
- St Jacques*, *see* Duclos, M. F.
- San Juan de las Abadesas, 94, 200
- St Marcel, Morbihan, 358
- St Michel-en-Grève, Côtes-du-Nord, 421
- St Nazaire, 64, 166, 243, 354, 358, 370, 421
- St Quentin, 239–40, 324
- Salerno, 249
- SALESMAN, F cct, 134, 234–6, 258, 336, 357, 359–60, 363, 416, 417, 467
- Salmon*, *see* Soulas, de
- SAMWEST, SAS party, 356–7
- Sansom, O. M. C., GC, MBE, 180, 188–9, 225–6, 227, 298, 374, 378, 379–80, 414
- Saône-et-Loire, 222–4
- SAP, 203, 311, 319
- Sark, 169
- Sarrette, p., 327, 361
- Sarthe, 158, 283
- SAS troops, 344, 350, 351–2; in France, 1944, 77, 169, 340, 353–9, 370–1, 388, 471; nature, 33, 131, 323–4; operations in Africa, 1942–3, 381; value, 355
- SATIRIST, F cct, 230, 240, 258, 284, 297, 466–7
- Saumur, 204

- SAVANNA, gaullist raid, xxi–xxii, 22, 140–1, 144–5, 151, 470; proves operations possible, 141, 145, 470
- Savoy, 133, 257, 314–15, 328–9, 354, 362
- Savy, W. J., 232, 261, 325
- Sawyer, *see* Sarrette
- Scamaroni, J. MC, 152, 409, 498n28
- Scapin*, *see* Serreules
- scent, 49
- scepticism, 6, 277, 396
- Schelle, J. B. van, 289
- Schmidt, P. F., OBE, 203
- Schock, A. L., MC, 373
- SCHOLAR, F cct, 329, 361, 416, 467
- School for Danger*, *see* film
- schools, *see* training in UK
- SCIENTIST, F cct: launched, 180; at work, 180, 248–52, 258, 277, 332, 350, 359, 417, 466–7; collapses, 209, 310, 333; re-forms, 304, 336, 386–7, 466–7
- SCULLION, F raids, 224, 263, 359
- SD, *see* security forces, German
- sea raiding, *see* Commando raids: transport, SOE's, 60–71, *see also* ships
- Seailles, P., 239
- SEALING-WAX, wireless game, 202, 303
- secrecy: necessary, 13, 395; unnecessary, 166
- secret armies: gaullist, 207, 252; mythical, 184–9; in principle, 184, 207, 337
- secret services: American, 16, 31, *see also* OSS; British, ix, 8–9, 33, 50–1, 130, 206–7, 209–10, 273–4, 395; gaullist French, *see also* BCRA; DGER; de Gaulle threatens to abolish, 207; German, *see* security forces; Soviet Russian, *see also* NKVD
- security: indispensable, ix, 13, 111–12, 254, 275, 303, 309–10, 330, 340; neglected, 184, 197, *see also* carelessness
- security checks: betrayed, 296, 300; ignored, 292–3; useful, 202, 303, 306; wireless, system, 99, 101–2
- Security Forces:
- French, Vichy, 181; *agents de police*, 203; customs police, 96, 221; gendarmes, 110; general, 106–7, 110–11; GMR, 238, 328; milice, 110–11, 328–9; unspecified, 332
 - German: Abwehr, 107–8, 110, 244, 246, 260, 263–4, 267, 270, 401; Feldgendarmerie, 96, 108, 257, 278, 320; Gestapo, 107–9, 182, 215, 321, 322, 327, 333, 337, 356; GFP, 108; guards, 209, 241, 385; SD interpenetrated with Gestapo, 107–9, 260, 263–4, 294; section IV F, 98, 109–10, 114–15, 132, 246, 269–71, 291–308, 331, 341–2, 344, 356, 403
 - Spanish, 88, 94
 - unspecified, 114, 276–7, 310, 331, *see also* concentration camps
- security services
- British, 33, 130; sees through Déricourt, 260, 268–9
 - gaullist, 23, 213–14
 - SOE's, 39, 57, 85, 246, 268, 270, 321; paper by, cited, 51
 - Vichy French, 181, *see also* security forces
- Seine valley, 352, 356, 360; department, *see* Fresnes; Issy; Paris; et Marne, 283–4, 326
- Selborne, R. C. P., 3rd earl of, CH, 18, 48, 131, 170, 198, 211, 311–14, 321, 453, 470
- Sereni, 331, 500n89
- Serge*, *see* Balachowsky
- Serreules, C-B., 216, 218, 308
- Servagnat, 410
- Service maquis*, *see* Maquis, *service*
- Seton-Watson, R. W., 119
- Sevenet, H. P., 92, 181–2, 192, 254, 262, 332, 361
- SF detachments, 344
- SFHQ, 32–3, 340, 355, 359, 387–8, 471
- SFIO, 220, 334
- SHAEF, 33, 321, 337, 341, 352, 388, 501n34
- SHAMROCK, raid, 138–9
- Sharpe, *see* Kieffer, J. L.
- Shelley*, *see* Yeo-Thomas
- Sheppard, R. M., 76, 193, 374
- SHINOILE mission, 354, 370, 421
- ships:
- French, 66; *Casabianca*, 66, 345, *see also* Mers-el-Kebir; Toulon
 - German: *Scharnhorst*, 172; *Tirpitz*, 166, *see also* targets; U-boats
 - HM: feluccas, 65, 170, 181, 187, 188–9, 195; *Fidelity*, 65–6, 141; *Maid Honor*, 168; small craft, 62–4, 66–7, *see also* var; submarines, 61–2, 66, 132, 170, 177, 183, 420–1; *Tigris*, 141
 - Japanese, *see* targets
- SHIPWRIGHT, F cct, 112, 335, 342, 356, 363, 467
- Shirer, W., 410
- SHRIMP, RF mission, 205
- Sicily, 169, 470
- Sicot, A., 70
- Sif*, *see* Boutoule; Fassin
- signals: *see also* security checks, wireless; details, 99–102, 291–2; SOE's policy, 94–8
- Sikorski, W., GBE, 25, 65, 170
- 'silent killing', 54, 403
- SILVERSMITH, F cct, 329, 417, 467
- Simon, A. L. E. H., MBE, 181, 184, 261
- Simon, O. A. G.: (1), 230, 240, 262, 284, 286; (2), 297, 307
- Simone*, *see* Leigh
- Simonet*, *see* O'Sullivan
- Sinclair, Sir A. (Lord Thurso), KT, CMG, 80–5, 313
- Sinclair, J., 330–1
- Sirois, A. L. J., 332
- Skate*, *see* Lardy
- Skepper, C. M., 229, 261, 330–1
- SLING, RF raid, 222
- SMGs, *see* weapons
- smuggling, 88, 142, 322, 368
- SNFC, *see* railways
- SNOW-WHITE, mission, 354
- 'snowballing', 70, 140, 275
- SO, 17, 29, 31, 39
- SO1, 11, 19, 40, 150, 389
- SO2, 11, 19, 29, 40, 61, 138, 150, 389
- SO3, 19–20
- Sochaux, Doubs, 256
- social origins, *see* class divisions
- Socialists, 198; British, 17, 161; French, 220, 334
- Socrate*, *see* Racheline
- SOE, *see also* agents; chain of command; communications; errors; planning; sabotage; targets: origins, x, xx, ch i; aims, xx–xxi, xxii, 13–15, 149–50, 165, 210–11; higher organisation, 16–28, 31–40, 268; place in war machine, 165–6; strength, 16, 387; strength, in France, 76, 85, 422; value, xi, 133, 146–7, 156; character, xx–xxv,

- 42–3; disbanded, ix, 395, 471; winding-up party, 45
- SOE/SO, 31–2, 341–2
- Solange*, see Damerment
- Sologne, 279, 336–7, 405
- Soltikow, count, 410
- Somers, J., see Gros
- Somers, M., 418
- Sophie*, see Serreules
- Sorbonne, 181
- Souillac, Lot, 351
- Soulas, J. de, 205
- Soustelle, J., 23, 126, 319, 410
- South Africa, 60
- Southgate, M., DSO, 112, 127, 252–6, 258, 262, 292, 334–5, 374, 386
- Spain, 9, 87–8, 92–4, 152, 175, 200, 289–90, 370, 372; agents pass through, *passim*
- Spanish resisters, 159, 328, 366, 370
- Speaight, R. L., 312
- Spears, Sir E. L., KBE, CB, MC, xii, 18, 129, 411
- Sphère*, see Fourcaud
- S-phone, 68–9, 79–80, 95, 294
- SPINDLE, F cct, 186–8, 194, 246, 414, 466–7
- SPIRITUALIST, F cct, 262, 325, 342, 359, 361, 364, 467
- SPOC, headquarters, 33, 130, 471
- Spooner, F. V., 298–9
- Sporborg, H. N., CMG, 15, 19, 20, 29, 49, 161, 268, 312, 321
- SPRUGE, F cct, 189–94, 255, 262, 329, 466–7
- SS, see security forces, German; Waffen-SS
- SSRF, 167–9, 176
- Staggs, A. A. G., 200, 237, 275
- Stalin, J. V., 16, 31, 146, 198, 389, 470
- Starf, G. R., DSO, MC, 43, 87, 91–2, 103, 127, 134, 180, 189, 243, 252, 254, 276, 310, 332, 339, 350, 362, 369
- Starf, J. A. R., 253, 374, 408; (1), 189; (2), 255–6; in prison, 294–6, 300, 307, 335
- STATIONER, F cct, 112, 127, 252, 258, 298, 385, 466–7; broken up, 318–19, 415
- Staunton, see Liewer
- Stead, P. J., 411
- Steele, A., 229, 330, 503n19
- Stens, see weapons
- Stirling, D., DSO, OBE, 434
- STO, xxiv, 125, 252
- STOCKBROKER, F cct, 256, 263–4, 327, 370–1, 384, 385, 415, 467
- Stonehouse, B. J., 192–3, 374, 376
- Strasbourg, 7
- strategy: allied, 135, 137, 210, 211–12, see also directives; German, 124–5; SOE's, see SOE
- Stratton, V., 167
- STS, 13, 40, 52–8, 345, see also training
- Stuart, Sir C., KCMG, KBE, 4
- Student, K., 16
- students, 161, 181, 194, 201, 233
- Studler, A., 360
- sub-machine guns, 6, see also weapons
- submarines, see ships; U-boats
- subversion, xxi, 10–11, 122–3, 348–9, 357, 364–7
- Sühren, F., 378
- supply: by air, 74, 76–9, 81–2, 200, 212, 229, 240, 247, 249, 253, 290, 291, 311–16, 332, 363–4, 421, 470; by land, 94, 328; by sea, 420–1
- surprise, 14
- SURVEYOR, abortive F cct, 258, 302, 305, 306, 467
- SUSSEX parties, not SOE's, 359
- Sutill, F. A., DSO, 127, 134, 179, 230–1, 248, 252, 258, 260, 266, 273, 274–6, 279–86, 287, 288, 297, 302, 308, 310, 324, 375
- Suzanne*, see Blanc
- SWAN, SAS raids, 357, 371
- Sweet-Escott, B. A. C., 22, 411
- Switzerland, 89, 94, 102, 133, 143, 196, 229, 240, 247, 257, 259, 283, 327, 346
- Sylvain*, see Vomécourt, Pierre de
- Sylvestre*, see Trotobas
- Syria, 259, 439, 470
- Szabo, V. R. E., GC, 407–8, 411; (1), 336; (2), 360, 417; in German hands, 374, 378–9
- T section, 21, 161
- tactics: clandestine, 217–27, 238, 275–6, 285, 439, 445, 448, ch iv, see also flair; security; elementary infantry, 54, 191, 347–8
- Tambour, G. and N., 275, 280
- Tanant, P., 411
- Tangmere, Sussex, 72, 78, 144, 261, 265
- Tanguy, H., 364
- Tania*, see Olschanesky
- Tarbes, H-Pyrénées, 253, 255, 332, 461
- Tarentaise, 314
- targets, SOE's: aircraft and airfields, 141, 144, 176, 309, 333–4; aircraft industry, 333–4, 455; army, German, communications, 173, 210, 243, 254, 309, 382, see also below; railways; roads; telephones; army, German, morale, 309, 382, 384–5; army, German, reinforcements, 349–51, 386–7; canals, 222–4, 324, 384, 470; coal, 454; electric power, 144–5, 181, 223, 231, 234, 254, 447, 455ff; factories, 238, 254, 453ff; oil, 156, 240, 382; railways, 240, 241–2, 246–7, 387, 448, see also derailments; roads, 309, 347–8, 386–7; ships, 26–7, 149, 248; telephones, 240, 254, 309, 387, 448; U-boats, 242–3, 248, 382
- Tarn, 332
- Tasca, G., see Rossi, A.
- Tedder, Sir A. W. (Lord), GCB, 341
- Teitgen, P-H., 151, 161
- telephones, 40, 89, 105, 297, 344, 386, 445, 462, see also targets
- Tempford, 72–4, 78
- Tessier, P. R., MC, 324, 361
- Thackthwaite, H. H. A., OBE, 49, 315–16, 339, 344, 354, 372, 397; cited, 207, 216, 318–19
- Theodore*, see Tessier
- Theodule*, see Brouville, de
- Thomas, J., 411
- Thomé, J., 153, 205
- Thompson, W. F., 43
- Thorez, M., 390
- Tickell, J., 87, 411
- TILLEUL mission, 134, 354, 363, 467
- Tillon, C., 26, 411
- Tilly, F. M. C., 138
- time pencils, see weapons
- Times*, *The*, see press
- timing, see punctuality
- TINKER, F cct, 127, 134, 241–4, 402, 466–7

- Tir*, see Ledoux, G.
 TITANIC, SAS raids, 340–1
 Tito, see Broz
Toinot, see Erainger, d'
 Tolkien, J. R. R., 107
Tomas, see Amps
 Tonkin, J. E., MC, 356
 TORCH, invasion, 31, 187, 197–9, 207, 390, 470
 Torr, P., 292
 TORTURE, RF cct, 151
 torture, 47, 143, 239, 269, 284, 285–6, 320, 329, 378–9, 409
 Toulon, 199, 203, 330, 411
 Toulouse, 94, 332, 370; de Gaulle at, 369; F at, 87, 102, 133, 188, 190, 195–7, 244–7, 254, 342; RF at, 151
 Tours, 179, 182, 260–1, 265, 273, 356, 450
 Tracy, C. F., 167
 training, agents: in the field, 107, 187–8, 192, 443; in the U. K., 52–8, 95, 103, 176, 182, 224, 233, 260, 275, 285, 298, 300, 395
 traitor in Baker Street, the mythical, 106, 115, 246, 285
 transmitters, W/T, 95–6
 treachery, 41, 101, see also double agents
 TREASURER, F cct, 327, 467
 Treasury, 17, 40, 122, 126, 142, 256
 Treffond, see Bolliadière
Triangle, see Gaillard
 TROMBONE, RF cct, 152
 Trotobas, M. A.: (1), 156, 162, 183; (2), 50, 183, 200, 232, 237–40, 243–4, 256, 275, 281, 283, 310, 324, 456
 Trotsky, see Bronstein, L. D.
 TROY, DF line, 142
 Troyes, 112, 240–3, 342, 450
 TRUEFORM, SAS parties, 357, 371
 Tunisia, 197
 Tunmer, see Turck
 Turberville, D., 157–9
 Turck, G. C. G., MC, 154, 155, 157, 195
 TUTOR, F raid, 133, 467
- U-boats, 222, 242–3, 248, 382, 470; bases, 64, 144, 167
 Ulyanov, V. I., 115, 122, 233
 unarmed combat, 54, 169
 Unienville, A. d', 418
 uniform, xxi, 43, 48, 315
 UNION mission, 315–16, 346–7
 UNION II, 346–7
 UNION III, 346–7
 unity, see resistance
 Unternährer, see Beckman
Urbain, see Bloom
 URCHIN, F cct, 158, 184, 187, 194, 466–7
 USA, xxiii, 123, 125, 129, 163, 197–8, 206, 212, 321, 340–1, 362, 389, 470, see also OSS; USAAF; archives service, cited, 362, 398
 USAAF, 31–3, 71, 74, 75, 82–5, 313, 358, 389, see also pick-ups, Dakota
 USSR, xxiii, 119, 123, 125, 317–18, 321, 442, 470, see also Communist parties; NKVD; and Darlan, 198; invaded, 145–6
- V1, V2, 310, 313, 324, 325
Valentin, see Goldsmith; Macalister
Valerian, see Blondet
- Vallée, F., MC, 233–4, 264
 Valrimont, M., 318
 Vannes, 141, 357
 Vansittart, Sir R., GCB, GCMG, MVO, 10, 19
 VAR, DF line, 50, 64, 67–71, 90, 224, 284, 294, 321, 323, 326, 336, 420
 Varnier, 144–5
 Vatan, Indre, 148, 449
 Vautrin, Col, 187
 VERGANIN JEDBURGH, 76
 Vendée, 205, 248, 354
 Vendôme, Loir-et-Cher, 178, 261, 266
 VENI groups, 334
Veni, see Vincent
Vénitien, see Gros
 VENTRILOQUIST, F cct, 134, 181–3, 192, 194, 230, 336–7, 341, 350, 363, 414, 417, 466–7
 Vercors, 51, 313, 315–16, 344–6, 347, 351, 354, 358, 411, 471
Verger, see Dandicolle
 VÉRITÉ movement, 151
 Verity, H. B., DSO, DFC, 87, 261; his notes on pick-ups, 427–36
 Verlaine, P., 341
Vernon, see Ziegler
 VERVEINE mission, 339, 355–6
 VIC, DF line, 28, 88–94, 102, 143, 170, 194, 224, 262–5, 290, 321, 323
Vic, see Gerson, H. V.
 Vichy regime, xxi, 120–5, 220, 430; forces, see army; town, 60, 121, 143, 152, 158
Vidal, see Delestrait
 VIDAL, plan, 316
 Villameur, L., MBE: (1), 414; (2), 417
 Villevielle, J., 330
Villon, see Ginzburger
 Vincent, H., 334
 Vogt, E., 277, 285, 294, 300
 Vogüé, Comte J. M. A. de, 318
Volume, see Conus
 Vomécourt, baron de Crevoisier de, Jean, 149, 160
 Vomécourt, Philippe, DSO: book cited, 50, 148–9, 160; mobilised by his brother, 134, 156, 160, 162, 173, 180–2, 191–2, 194–6, 230, 297, 336–7, 341, 350, 363, 412; escape, 332; in prison, 182–3
 Vomécourt, Pierre, original F organizer: (1), 127, 148–9, 154, 156, 158–61, 338; and Mme Carré, 159, 171–5; (2), 174, 175, 179; in prison, 174–5, 373
 Vosges, 354
- WAAF, 47–8, 298, 383, 415–17
 Waffen-SS, 349–51, 356, 362, 386–7
 Wake, see Fiocca
 WALLACE, SAS operation, 356–7, 403
 Walters, A-M, MBE, 332, 412, 416; cited, 362
 Wanborough, Surrey, 53, 147, 154
 wars:
 Trojan, 3
 hundred years, 128, 332;
 1792–1815, 9, 316;
 1870–1, 146, 364; 1914–18, 3–4, 21, 200;
 1939–45: impending, 3, 6–7; course, 468–71; first phase, 7–8; 1940 collapse, 8, 136, 389; in Mediterranean, 197–200, 249, 381, 384; in

- Pacific, 210, 248, 343; in Russia, 145–6, 209, 442, in north-west Europe, *passim*;
- War Cabinet, xxiii, 8, 10, 120, 208, 230, 312; approves SOE, 10–11
- war diary: MI R, 7–8, 48; SAS, 356, 357–9; SOE, 19, 40, 41, 138–9, 147, 167, 397
- War Office, 8, 13, 43, 52, 380
- Ward, (Dame) I. M. B. (DBE), 412
- Warenghem, S., 412
- Warrington-Smyth, B., 64
- Warsaw, 6, 352, 471
- Washington files, *see* USA, archives service
- Watney, C. A., 333
- Watt, A. P. A., MBE, MC, 262, 272–3, 326
- weapons, SOE: abrasive grease, 195, 240, 247; ammunition, 314, 424–6; artillery, none, 77, 316, 344; bazookas, 77, 316, 424–6; Bren guns, 247, 347–8, 424–6; carbines, 347–8, 424–6; cyanide, *see* lethal tablets (below); detonators, 55, 144–5, 323, *see also* time pencils; explosives, dynamite, 323; explosives, plastic, 55–6, 144–5, 150, 191, 235, 240–1, 247, 333–4, 383, 453ff; grenades, 5, 77, 222, 329, 362, 424–6; itching powder, 242; knives, 54, 150; lethal tablets, for suicide, 202, 219, 320; limpets, 27, 150, 236; machine guns, 316; mortars, 77, 361; pistols and revolvers, 54, 364, 421; rifles, 347–8, 424–6; stens, 247, 314–15, 356, 424–6; sub-machine guns, 6, 150, 424–6; time pencils, 5, 166, 204, 235, 238, 241–7; Welman, 167
- weather, 60, 134, 159, 165, 206, 208, 311, 313
- Webb, A. M., 412
- Webster, Sir C., KCMG, and Frankland, A. N., DFC, 412; cited, 383
- Weil, J., OBE, 230–1, 283, 412
- Welman, *see* weapons
- Weygand, M., 121, 125
- Wheeler-Bennett, (Sir) J. W., OBE, cited, 502n68
- WHEELWRIGHT, F cct, 127, 133, 134, 243, 252, 254, 304, 310, 332, 336, 339, 350, 363, 369, 415, 416, 466–7
- Wilen, O. V., 335–6, 417
- Wilkinson, E. M., 177–8, 199–200, 231, 279
- Wilkinson, G. A., 360, 375
- Wilkinson, P. A., DSO, 7, 412
- Willk, A., 354
- Wimille, J-P, 287, 336, 360
- Wimille, Mme, 287; escape, 360
- Winter, T., 374
- Wintle, A. D., 412
- wireless, 56, 95–103, 126, 158–9, 204–5, 273, 388, 449–52
- 'wireless games': British, 171–2, 201–2, 296–8, 327; German, 98, 171–2, 244, 246, 285, 291–423, 324, 341–2
- wireless operators, typical orders for, 450–2, *see also* wireless
- Witherington, P., MBE (mil), 48, 335, 342, 350, 383, 386, 415
- WIZARD, F cct, 325, 359, 416, 467
- Woerther, A. V., 307
- Wollaston, J. McA., 74, 504n10
- Wolters, L., 174
- women, *see also* FANY; WAAF: as agents, *see* agents; names listed, 435–9; on staff, 47
- WOODCHUCK, *see* GREYHOUND
- WOODCUTTER, F cct, 307
- Wooler, J. R., 78
- Worms, J., 230–1, 283, 286
- WRESTLER, F cct, 48, 112, 335–7, 342, 350, 383, 415, 467
- W/T, *see* wireless
- WTS, *see* FANY
- Wyatt, D., 167
- Wynne, B., 412
- Xan*, *see* Fielding
- Xavier*, 153, *see also* Heslop
- Yeo-Thomas, F. F. E., GC, MC: and, 407; (1), 46, 214; (2), 215–19, 221, 239, 310; in London, 131, 311–12; (3), 320; in prison, 28, 46, 114, 320; escape from Buchenwald, 373–5, 410; after war, 202, 204
- Yonne, 361
- Young, G., cited, 412
- Young, J. C., 256, 263–4
- Yugoslavia, 20, 78, 119, 211, 314, 316–17, 470
- Yvon*, *see* Morandat, Y
- Yvonne*, *see* Beckman
- Zeff, E., MBE, 177, 190, 374
- Zeller, H., 262
- Zembsch-Schrewe, 113, 224, 374
- Ziegler, A., 339, 502n72
- ZL, ZNO, 110, 151, 199, 202, 206, 319–20, 334, 363, 388, 438, 440
- ZO, 131, 203, 319, 353, 438, 440
- zone interdite*, 61, 63–71, 165–70, 290, 319–20