

Instructor's Solutions Manual

ENGINEERING MECHANICS

STATICS

TENTH EDITION

R. C. Hibbeler



Pearson Education, Inc.
Upper Saddle River, New Jersey 07458

Executive Editor: *Eric Svendsen*
Associate Editor: *Dee Bernhard*
Executive Managing Editor: *Vince O'Brien*
Managing Editor: *David A. George*
Production Editor: *Barbara A. Till*
Director of Creative Services: *Paul Belfanti*
Manufacturing Manager: *Trudy Piscioti*
Manufacturing Buyer: *Ilene Kahn*

About the cover: The forces within the members of this truss bridge must be determined if they are to be properly designed. *Cover Image:* R.C. Hibbeler.



© 2004 by Pearson Education, Inc.
Pearson Prentice Hall
Pearson Education, Inc.
Upper Saddle River, NJ 07458

All rights reserved. No part of this book may be reproduced in any form or by any means, without permission in writing from the publisher.

The author and publisher of this book have used their best efforts in preparing this book. These efforts include the development, research, and testing of the theories and programs to determine their effectiveness. The author and publisher make no warranty of any kind, expressed or implied, with regard to these programs or the documentation contained in this book. The author and publisher shall not be liable in any event for incidental or consequential damages in connection with, or arising out of, the furnishing, performance, or use of these programs.

Pearson Prentice Hall[®] is a trademark of Pearson Education, Inc.

Printed in the United States of America

10 9 8 7 6 5 4 3 2 1

ISBN 0-13-141212-4

Pearson Education Ltd., *London*
Pearson Education Australia Pty. Ltd., *Sydney*
Pearson Education Singapore, Pte. Ltd.
Pearson Education North Asia Ltd., *Hong Kong*
Pearson Education Canada, Inc., *Toronto*
Pearson Educación de Mexico, S.A. de C.V.
Pearson Education—Japan, *Tokyo*
Pearson Education Malaysia, Pte. Ltd.
Pearson Education, Inc., *Upper Saddle River, New Jersey*

Contents

| | | |
|----|--------------------------------|-----|
| 1 | General Principles | 1 |
| 2 | Force Vectors | 5 |
| 3 | Equilibrium of a Particle | 77 |
| 4 | Force System Resultants | 129 |
| 5 | Equilibrium of a Rigid Body | 206 |
| 6 | Structural Analysis | 261 |
| 7 | Internal Forces | 391 |
| 8 | Friction | 476 |
| 9 | Center of Gravity and Centroid | 556 |
| 10 | Moments of Inertia | 619 |
| 11 | Virtual Work | 680 |



1-1. Round off the following numbers to three significant figures: (a) 4.65735 m, (b) 55.578 s, (c) 4555 N, (d) 2768 kg.

a) 4.66 m b) 55.6 s c) 4.56 kN d) 2.77 Mg **Ans**

1-2. Wood has a density of 4.70 slug/ft³. What is its density expressed in SI units?

$$(4.70 \text{ slug/ft}^3) \left\{ \frac{(1 \text{ ft}^3)(14.5938 \text{ kg})}{(0.3048 \text{ m})^3(1 \text{ slug})} \right\} = 2.42 \text{ Mg/m}^3 \quad \text{Ans}$$

1-3. Represent each of the following quantities in the correct SI form using an appropriate prefix: (a) 0.000431 kg, (b) 35.3(10³) N, (c) 0.00532 km.

a) 0.000431 kg = 0.000431 (10³) g = 0.431 g **Ans**

b) 35.3 (10³) N = 35.3 kN **Ans**

c) 0.00532 km = 0.00532 (10³) m = 5.32 m **Ans**

*1-4. Represent each of the following combinations of units in the correct SI form using an appropriate prefix: (a) m/ms, (b) μkm, (c) ks/mg, and (d) km · μN.

(a) m/ms = $\left(\frac{\text{m}}{(10)^3 \text{ s}} \right) = \left(\frac{(10)^3 \text{ m}}{\text{s}} \right) = \text{km/s}$ **Ans**

(b) μkm = (10)⁻⁶(10)³ m = (10)⁻³ m = mm **Ans**

(c) ks/mg = $\left(\frac{(10)^3 \text{ s}}{(10)^{-6} \text{ kg}} \right) = \left(\frac{(10)^9 \text{ s}}{\text{kg}} \right) = \text{Gs/kg}$ **Ans**

(d) km · μN = [(10)³ m][(10)⁻⁶ N] = (10)⁻³ mN = mmN **Ans**

1-5. If a car is traveling at 55 mi/h, determine its speed in kilometers per hour and meters per second.

$$55 \text{ mi/h} = \left(\frac{55 \text{ mi}}{1 \text{ h}} \right) \left(\frac{5280 \text{ ft}}{1 \text{ mi}} \right) \left(\frac{0.3048 \text{ m}}{1 \text{ ft}} \right) \left(\frac{1 \text{ km}}{1000 \text{ m}} \right) = 88.5 \text{ km/h} \quad \text{Ans}$$

$$88.5 \text{ km/h} = \left(\frac{88.5 \text{ km}}{1 \text{ h}} \right) \left(\frac{1000 \text{ m}}{1 \text{ km}} \right) \left(\frac{1 \text{ h}}{3600 \text{ s}} \right) = 24.6 \text{ m/s} \quad \text{Ans}$$

1-6. Evaluate each of the following and express with an appropriate prefix: (a) (430 kg)², (b) (0.002 mg)², and (c) (230 m)³.

(a) (430 kg)² = 0.185(10⁶) kg² = 0.185 Mg² **Ans**

(b) (0.002 mg)² = [2(10⁻⁶) g]² = 4 μg² **Ans**

(c) (230 m)³ = [0.23(10³) m]³ = 0.0122 km³ **Ans**

1-7. A rocket has a mass of 250(10³) slugs on earth. Specify (a) its mass in SI units, and (b) its weight in SI units. If the rocket is on the moon, where the acceleration due to gravity is g_m = 5.30 ft/s², determine to three significant figures (c) its weight in SI units, and (d) its mass in SI units.

Using Table 1-2 and applying Eq. 1-3, we have

a) 250(10³) slugs = $\left[250(10^3) \text{ slugs} \right] \left(\frac{14.5938 \text{ kg}}{1 \text{ slug}} \right) = 3.64845(10^6) \text{ kg} = 3.65 \text{ Gg}$ **Ans**

b) W_e = mg = $\left[3.64845(10^6) \text{ kg} \right] (9.81 \text{ m/s}^2) = 35.791(10^6) \text{ kg} \cdot \text{m/s}^2 = 35.8 \text{ MN}$ **Ans**

c) W_m = mg_m = $\left[250(10^3) \text{ slugs} \right] (5.30 \text{ ft/s}^2) = \left[1.325(10^6) \text{ lb} \right] \left(\frac{4.4482 \text{ N}}{1 \text{ lb}} \right) = 5.894(10^6) \text{ N} = 5.89 \text{ MN}$ **Ans**

Or

W_m = W_e $\left(\frac{g_m}{g} \right) = (35.791 \text{ MN}) \left(\frac{5.30 \text{ ft/s}^2}{32.2 \text{ ft/s}^2} \right) = 5.89 \text{ MN}$

d) Since the mass is independent of its location, then

m_m = m_e = 3.65(10⁶) kg = 3.65 Gg **Ans**

*1-8. Represent each of the following combinations of units in the correct SI form: (a) $\text{kN}/\mu\text{s}$, (b) Mg/mN , and (c) $\text{MN}/(\text{kg} \cdot \text{ms})$.

- (a) $\text{kN}/\mu\text{s} = 10^3 \text{N}/(10^{-6})\text{s} = \text{GN}/\text{s}$ **Ans**
 (b) $\text{Mg}/\text{mN} = 10^6 \text{g}/10^{-3} \text{N} = \text{Gg}/\text{N}$ **Ans**
 (c) $\text{MN}/(\text{kg} \cdot \text{ms}) = 10^6 \text{N}/\text{kg}(10^{-3} \text{s}) = \text{GN}/(\text{kg} \cdot \text{s})$ **Ans**

1-9. The *pascal* (Pa) is actually a very small unit of pressure. To show this, convert $1 \text{ Pa} = 1 \text{ N}/\text{m}^2$ to lb/ft^2 . Atmospheric pressure at sea level is $14.7 \text{ lb}/\text{in}^2$. How many pascals is this?

Using Table 1-2, we have

$$1 \text{ Pa} = \frac{1 \text{ N}}{\text{m}^2} \left(\frac{1 \text{ lb}}{4.4482 \text{ N}} \right) \left(\frac{0.3048^2 \text{ m}^2}{1 \text{ ft}^2} \right) = 20.9 (10^{-3}) \text{ lb}/\text{ft}^2 \quad \text{Ans}$$

$$\begin{aligned} 1 \text{ ATM} &= \frac{14.7 \text{ lb}/\text{in}^2}{\left(\frac{1 \text{ lb}}{4.4482 \text{ N}} \right) \left(\frac{144 \text{ in}^2}{1 \text{ ft}^2} \right) \left(\frac{1 \text{ ft}^2}{0.3048^2 \text{ m}^2} \right)} \\ &= 101.3 (10^3) \text{ N}/\text{m}^2 \\ &= 101 \text{ kPa} \end{aligned} \quad \text{Ans}$$

1-10. What is the weight in newtons of an object that has a mass of: (a) 10 kg , (b) 0.5 g , (c) 4.50 Mg ? Express the result to three significant figures. Use an appropriate prefix.

- (a) $W = (9.81 \text{ m}/\text{s}^2)(10 \text{ kg}) = 98.1 \text{ N}$ **Ans**
 (b) $W = (9.81 \text{ m}/\text{s}^2)(0.5 \text{ g})(10^{-3} \text{ kg}/\text{g}) = 4.90 \text{ mN}$ **Ans**
 (c) $W = (9.81 \text{ m}/\text{s}^2)(4.5 \text{ Mg})(10^3 \text{ kg}/\text{Mg}) = 44.1 \text{ kN}$ **Ans**

1-11. Evaluate each of the following to three significant figures and express each answer in SI units using an appropriate prefix: (a) $354 \text{ mg}(45 \text{ km})/(0.0356 \text{ kN})$, (b) $(.00453 \text{ Mg})(201 \text{ ms})$, (c) $435 \text{ MN}/23.2 \text{ mm}$.

$$\begin{aligned} \text{a) } (354 \text{ mg})(45 \text{ km})/0.0356 \text{ kN} &= \frac{[354(10^{-3}) \text{ g}][45(10^3) \text{ m}]}{0.0356(10^3) \text{ N}} \\ &= \frac{0.447(10^3) \text{ g} \cdot \text{m}}{\text{N}} \\ &= 0.447 \text{ kg} \cdot \text{m}/\text{N} \end{aligned} \quad \text{Ans}$$

$$\begin{aligned} \text{b) } (0.00453 \text{ Mg})(201 \text{ ms}) &= [4.53(10^{-3}) (10^3) \text{ kg}][201(10^{-3}) \text{ s}] \\ &= 0.911 \text{ kg} \cdot \text{s} \end{aligned} \quad \text{Ans}$$

$$\text{c) } 435 \text{ MN}/23.2 \text{ mm} = \frac{435(10^6) \text{ N}}{23.2(10^{-3}) \text{ m}} = \frac{18.75(10^9) \text{ N}}{\text{m}} = 18.8 \text{ GN}/\text{m} \quad \text{Ans}$$

*1-12. Convert each of the following and express the answer using an appropriate prefix: (a) $175 \text{ lb}/\text{ft}^3$ to kN/m^3 , (b) $6 \text{ ft}/\text{h}$ to mm/s , and (c) $835 \text{ lb} \cdot \text{ft}$ to $\text{kN} \cdot \text{m}$.

$$\begin{aligned} \text{(a) } 175 \text{ lb}/\text{ft}^3 &= \left(\frac{175 \text{ lb}}{\text{ft}^3} \right) \left(\frac{\text{ft}}{0.3048 \text{ m}} \right)^3 \left(\frac{4.4482 \text{ N}}{\text{lb}} \right) \\ &= \left(\frac{27.5(10^3) \text{ N}}{\text{m}^3} \right) = 27.5 \text{ kN}/\text{m}^3 \end{aligned} \quad \text{Ans}$$

$$\begin{aligned} \text{(b) } 6 \text{ ft}/\text{h} &= \left(\frac{6 \text{ ft}}{\text{h}} \right) \left(\frac{0.3048 \text{ m}}{1 \text{ ft}} \right) \left(\frac{1 \text{ h}}{3600 \text{ s}} \right) \\ &= 0.508(10)^{-3} \text{ m}/\text{s} = 0.508 \text{ mm}/\text{s} \end{aligned} \quad \text{Ans}$$

$$\begin{aligned} \text{(c) } 835 \text{ lb} \cdot \text{ft} &= (835 \text{ lb} \cdot \text{ft}) \left(\frac{4.4482 \text{ N}}{1 \text{ lb}} \right) \left(\frac{0.3048 \text{ m}}{1 \text{ ft}} \right) \\ &= 1.13(10)^3 \text{ N} \cdot \text{m} = 1.13 \text{ kN} \cdot \text{m} \end{aligned} \quad \text{Ans}$$

1-13. Convert each of the following to three significant figures. (a) 20 lb · ft to N · m, (b) 450 lb/ft³ to kN/m³, and (c) 15 ft/h to mm/s.

Using Table 1-2, we have

$$\begin{aligned} \text{a) } 20 \text{ lb} \cdot \text{ft} &= (20 \text{ lb} \cdot \text{ft}) \left(\frac{4.4482 \text{ N}}{1 \text{ lb}} \right) \left(\frac{0.3048 \text{ m}}{1 \text{ ft}} \right) \\ &= 27.1 \text{ N} \cdot \text{m} \qquad \text{Ans} \end{aligned}$$

$$\begin{aligned} \text{b) } 450 \text{ lb/ft}^3 &= \left(\frac{450 \text{ lb}}{\text{ft}^3} \right) \left(\frac{4.4482 \text{ N}}{1 \text{ lb}} \right) \left(\frac{1 \text{ kN}}{1000 \text{ N}} \right) \left(\frac{1 \text{ ft}^3}{0.3048^3 \text{ m}^3} \right) \\ &= 70.7 \text{ kN/m}^3 \qquad \text{Ans} \end{aligned}$$

$$\text{c) } 15 \text{ ft/h} = \left(\frac{15 \text{ ft}}{\text{h}} \right) \left(\frac{304.8 \text{ mm}}{1 \text{ ft}} \right) \left(\frac{1 \text{ h}}{3600 \text{ s}} \right) = 1.27 \text{ mm/s} \qquad \text{Ans}$$

1-14. If an object has a mass of 40 slugs, determine its mass in kilograms.

$$40 \text{ slugs} (14.5938 \text{ kg/slug}) = 584 \text{ kg} \qquad \text{Ans}$$

1-15. Water has a density of 1.94 slug/ft³. What is the density expressed in SI units? Express the answer to three significant figures.

Using Table 1-2, we have

$$\begin{aligned} \rho_w &= \left(\frac{1.94 \text{ slug}}{\text{ft}^3} \right) \left(\frac{14.5938 \text{ kg}}{1 \text{ slug}} \right) \left(\frac{1 \text{ ft}^3}{0.3048^3 \text{ m}^3} \right) \\ &= 999.8 \text{ kg/m}^3 = 1.00 \text{ Mg/m}^3 \qquad \text{Ans} \end{aligned}$$

*1-16. Two particles have a mass of 8 kg and 12 kg, respectively. If they are 800 mm apart, determine the force of gravity acting between them. Compare this result with the weight of each particle.

$$F = G \frac{m_1 m_2}{r^2}$$

$$\text{Where } G = 6.673(10^{-11}) \text{ m}^3/(\text{kg} \cdot \text{s}^2)$$

$$F = 6.673(10^{-11}) \left[\frac{8(12)}{(0.8)^2} \right] = 10.0(10^{-9}) \text{ N} = 10.0 \text{ nN} \qquad \text{Ans}$$

$$W_1 = 8(9.81) = 78.5 \text{ N} \qquad \text{Ans}$$

$$W_2 = 12(9.81) = 118 \text{ N} \qquad \text{Ans}$$

1-17. Determine the mass of an object that has a weight of (a) 20 mN, (b) 150 kN, (c) 60 MN. Express the answer to three significant figures.

Applying Eq. 1-3, we have

$$\text{a) } m = \frac{W}{g} = \frac{20(10^{-3}) \text{ kg} \cdot \text{m/s}^2}{9.81 \text{ m/s}^2} = 2.04 \text{ g} \qquad \text{Ans}$$

$$\text{b) } m = \frac{W}{g} = \frac{150(10^3) \text{ kg} \cdot \text{m/s}^2}{9.81 \text{ m/s}^2} = 15.3 \text{ Mg} \qquad \text{Ans}$$

$$\text{c) } m = \frac{W}{g} = \frac{60(10^6) \text{ kg} \cdot \text{m/s}^2}{9.81 \text{ m/s}^2} = 6.12 \text{ Gg} \qquad \text{Ans}$$

1-18. If a man weighs 155 lb on earth, specify (a) his mass in slugs, (b) his mass in kilograms, and (c) his weight in newtons. If the man is on the moon, where the acceleration due to gravity is $g_m = 5.30 \text{ ft/s}^2$, determine (d) his weight in pounds, and (e) his mass in kilograms.

$$(a) \quad m = \frac{155}{32.2} = 4.81 \text{ slug} \quad \text{Ans}$$

$$(b) \quad m = 155 \left[\frac{14.5938 \text{ kg}}{32.2} \right] = 70.2 \text{ kg} \quad \text{Ans}$$

$$(c) \quad W = 155 (4.4482) = 689 \text{ N} \quad \text{Ans}$$

$$(d) \quad W = 155 \left[\frac{5.30}{32.2} \right] = 25.5 \text{ lb} \quad \text{Ans}$$

$$(e) \quad m = 155 \left[\frac{14.5938 \text{ kg}}{32.2} \right] = 70.2 \text{ kg} \quad \text{Ans}$$

Also,

$$m = 25.5 \left[\frac{14.5938 \text{ kg}}{5.30} \right] = 70.2 \text{ kg} \quad \text{Ans}$$

1-19. Using the base units of the SI system, show that Eq. 1-2 is a dimensionally homogeneous equation which gives F in newtons. Determine to three significant figures the gravitational force acting between two spheres that are touching each other. The mass of each sphere is 200 kg and the radius is 300 mm.

Using Eq. 1-2.

$$F = G \frac{m_1 m_2}{r^2}$$

$$N = \left(\frac{\text{m}^3}{\text{kg} \cdot \text{s}^2} \right) \left(\frac{\text{kg} \cdot \text{kg}}{\text{m}^2} \right) = \frac{\text{kg} \cdot \text{m}}{\text{s}^2} \quad (Q. E. D.)$$

$$F = G \frac{m_1 m_2}{r^2}$$

$$= 66.73 (10^{-12}) \left[\frac{200(200)}{0.6^2} \right]$$

$$= 7.41 (10^{-6}) \text{ N} = 7.41 \mu\text{N} \quad \text{Ans}$$

*1-20. Evaluate each of the following to three significant figures and express each answer in SI units using an appropriate prefix: (a) $(0.631 \text{ Mm})/(8.60 \text{ kg})^2$, (b) $(35 \text{ mm})^2(48 \text{ kg})^3$.

$$(a) \quad 0.631 \text{ Mm}/(8.60 \text{ kg})^2 = \left(\frac{0.631 (10^6) \text{ m}}{(8.60)^2 \text{ kg}^2} \right) = \frac{8532 \text{ m}}{\text{kg}^2}$$

$$= 8.53 (10^3) \text{ m/kg}^2 = 8.53 \text{ km/kg}^2 \quad \text{Ans}$$

$$(b) \quad (35 \text{ mm})^2(48 \text{ kg})^3 = [35 (10^{-3}) \text{ m}]^2 (48 \text{ kg})^3 = 135 \text{ m}^2 \text{ kg}^3 \quad \text{Ans}$$

2-1. Determine the magnitude of the resultant force $F_R = F_1 + F_3$ and its direction, measured counterclockwise from the positive x axis.

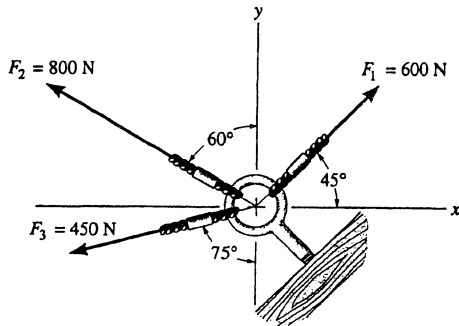

$$F_R = \sqrt{(600)^2 + (800)^2 - 2(600)(800)\cos 75^\circ} = 866.91 = 867 \text{ N} \quad \text{Ans}$$

$$\frac{866.91}{\sin 75^\circ} = \frac{800}{\sin \theta}$$

$$\theta = 63.05^\circ$$

$$\phi = 63.05^\circ + 45^\circ = 108^\circ \quad \text{Ans}$$

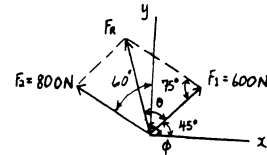

2-2. Determine the magnitude of the resultant force if:

(a) $F_R = F_1 + F_2$; (b) $F_R = F_1 - F_2$.

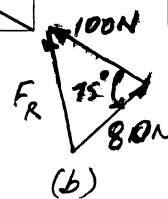
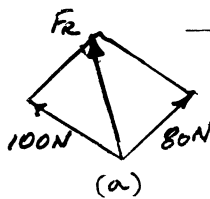

Parallelogram Law : The parallelogram law of addition is shown in Fig. (a) and (c).

Trigonometry : Using law of cosines [Fig. (b) and (d)], we have

a) $F_R = \sqrt{100^2 + 80^2 - 2(100)(80)\cos 75^\circ} = 111 \text{ N}$

b) $F_R' = \sqrt{100^2 + 80^2 - 2(100)(80)\cos 105^\circ} = 143 \text{ N}$

Ans

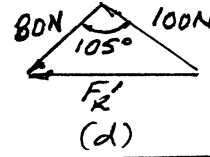
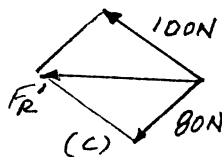

Ans

2-3. Determine the magnitude of the resultant force $F_R = F_1 + F_2$ and its direction, measured counterclockwise from the positive x axis.

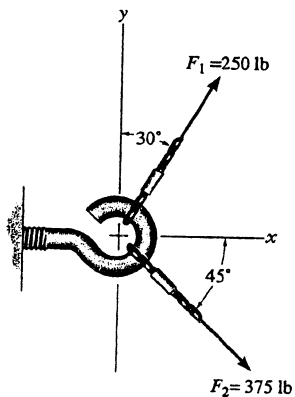

$$F_R = \sqrt{(250)^2 + (375)^2 - 2(250)(375)\cos 75^\circ} = 393.2 = 393 \text{ lb} \quad \text{Ans}$$

$$\frac{393.2}{\sin 75^\circ} = \frac{250}{\sin \theta}$$

$$\theta = 37.89^\circ$$

$$\phi = 360^\circ - 45^\circ + 37.89^\circ = 353^\circ \quad \text{Ans}$$

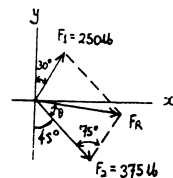

*2-4. Determine the magnitude of the resultant force $F_R = F_1 + F_2$ and its direction, measured clockwise from the positive u axis.

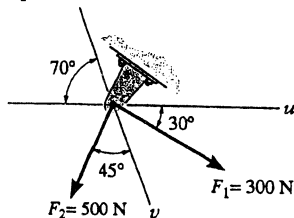

$$F_R = \sqrt{(300)^2 + (500)^2 - 2(300)(500)\cos 95^\circ} = 605.1 = 605 \text{ N} \quad \text{Ans}$$

$$\frac{605.1}{\sin 95^\circ} = \frac{500}{\sin \theta}$$

$$\theta = 55.40^\circ$$

$$\phi = 55.40^\circ + 30^\circ = 85.4^\circ \quad \text{Ans}$$

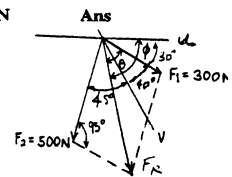

2-5. Resolve the force F_1 into components acting along the u and v axes and determine the magnitudes of the components.

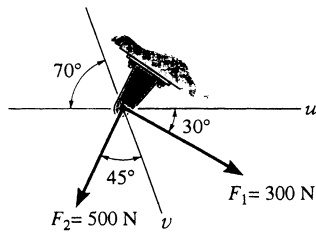

$$\frac{F_{1u}}{\sin 40^\circ} = \frac{300}{\sin 110^\circ}$$

$$F_{1u} = 205 \text{ N} \quad \text{Ans}$$

$$\frac{F_{1v}}{\sin 30^\circ} = \frac{300}{\sin 110^\circ}$$

$$F_{1v} = 160 \text{ N} \quad \text{Ans}$$

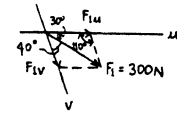

2-6. Resolve the force F_2 into components acting along the u and v axes and determine the magnitudes of the components.

$$\frac{F_{2u}}{\sin 45^\circ} = \frac{500}{\sin 70^\circ}$$

$$F_{2u} = 376 \text{ N} \quad \text{Ans}$$

$$\frac{F_{2v}}{\sin 65^\circ} = \frac{500}{\sin 70^\circ}$$

$$F_{2v} = 482 \text{ N} \quad \text{Ans}$$

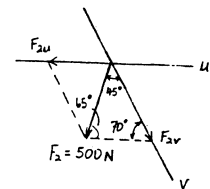

2-7. The plate is subjected to the two forces at A and B as shown. If $\theta = 60^\circ$, determine the magnitude of the resultant of these two forces and its direction measured from the horizontal.

Parallelogram Law : The parallelogram law of addition is shown in Fig. (a).

Trigonometry : Using law of cosines [Fig. (b)], we have

$$F_R = \sqrt{8^2 + 6^2 - 2(8)(6) \cos 100^\circ} = 10.80 \text{ kN} = 10.8 \text{ kN}$$

The angle θ can be determined using law of sines [Fig. (b)].

$$\frac{\sin \theta}{6} = \frac{\sin 100^\circ}{10.80}$$

$$\sin \theta = 0.5470$$

$$\theta = 33.16^\circ$$

Thus, the direction ϕ of F_R measured from the x axis is

$$\phi = 33.16^\circ - 30^\circ = 3.16^\circ$$

Ans

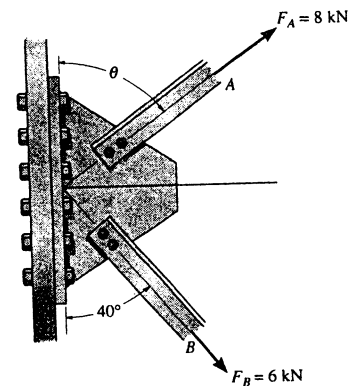

Ans

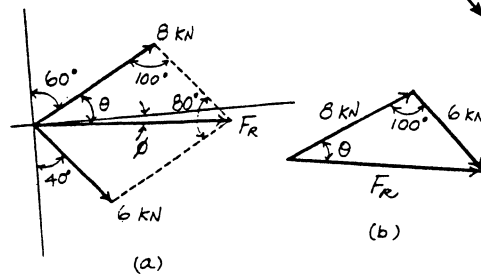

***2-8.** Determine the angle θ for connecting member A to the plate so that the resultant force of F_A and F_B is directed horizontally to the right. Also, what is the magnitude of the resultant force.

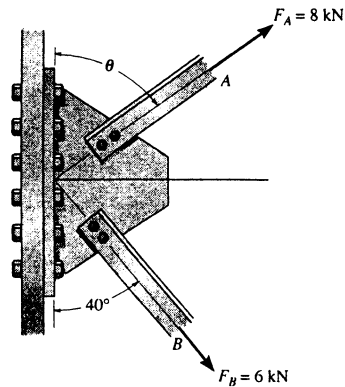

Parallelogram Law : The parallelogram law of addition is shown in Fig. (a).

Trigonometry : Using law of sines [Fig. (b)], we have

$$\frac{\sin(90^\circ - \theta)}{6} = \frac{\sin 50^\circ}{8}$$

$$\sin(90^\circ - \theta) = 0.5745$$

$$\theta = 54.93^\circ = 54.9^\circ$$

Ans

From the triangle, $\phi = 180^\circ - (90^\circ - 54.93^\circ) - 50^\circ = 94.93^\circ$. Thus, using law of cosines, the magnitude of F_R is

$$F_R = \sqrt{8^2 + 6^2 - 2(8)(6)\cos 94.93^\circ}$$

$$= 10.4 \text{ kN}$$

Ans

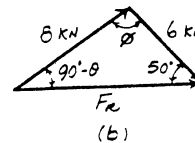
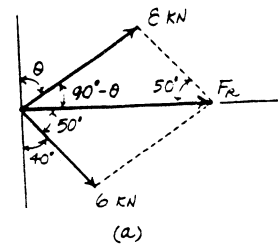

2-9. The vertical force F acts downward at A on the two-membered frame. Determine the magnitudes of the two components of F directed along the axes of AB and AC . Set $F = 500 \text{ N}$.

Parallelogram Law : The parallelogram law of addition is shown in Fig. (a).

Trigonometry : Using law of sines [Fig. (b)], we have

$$\frac{F_{AB}}{\sin 60^\circ} = \frac{500}{\sin 75^\circ}$$

$$F_{AB} = 448 \text{ N}$$

Ans

$$\frac{F_{AC}}{\sin 45^\circ} = \frac{500}{\sin 75^\circ}$$

$$F_{AC} = 366 \text{ N}$$

Ans

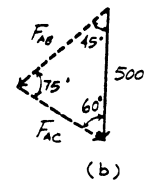
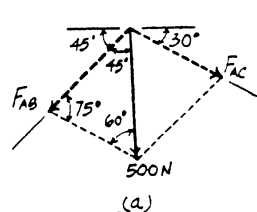
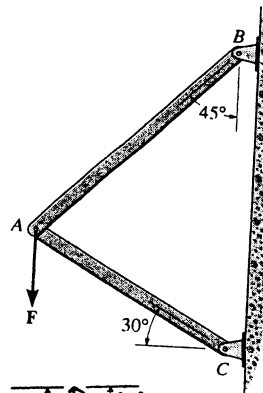

2-10. Solve Prob. 2-9 with $F = 350$ lb.

Parallelogram Law: The parallelogram law of addition is shown in Fig. (a).

Trigonometry: Using law of sines [Fig. (b)], we have

$$\frac{F_{AB}}{\sin 60^\circ} = \frac{350}{\sin 75^\circ}$$

$$F_{AB} = 314 \text{ lb} \quad \text{Ans}$$

$$\frac{F_{AC}}{\sin 45^\circ} = \frac{350}{\sin 75^\circ}$$

$$F_{AC} = 256 \text{ lb} \quad \text{Ans}$$

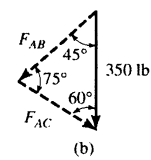
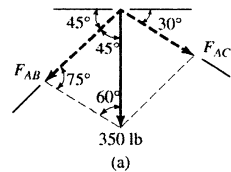
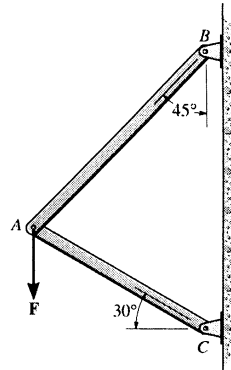

2-11. The force acting on the gear tooth is $F = 20$ lb. Resolve this force into two components acting along the lines aa and bb .

$$\frac{20}{\sin 40^\circ} = \frac{F_a}{\sin 80^\circ}, \quad F_a = 30.6 \text{ lb} \quad \text{Ans}$$

$$\frac{20}{\sin 40^\circ} = \frac{F_b}{\sin 60^\circ}, \quad F_b = 26.9 \text{ lb} \quad \text{Ans}$$

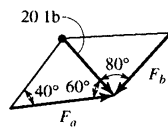
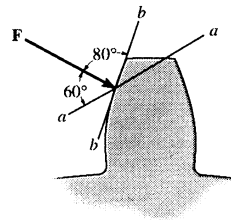

*2-12. The component of force F acting along line aa is required to be 30 lb. Determine the magnitude of F and its component along line bb .

$$\frac{30}{\sin 80^\circ} = \frac{F}{\sin 40^\circ}, \quad F = 19.6 \text{ lb} \quad \text{Ans}$$

$$\frac{30}{\sin 80^\circ} = \frac{F_b}{\sin 60^\circ}, \quad F_b = 26.4 \text{ lb} \quad \text{Ans}$$

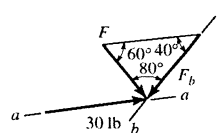
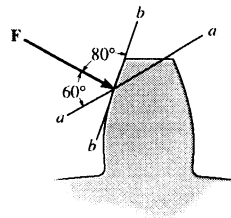

2-13. The 500-lb force acting on the frame is to be resolved into two components acting along the axis of the struts AB and AC . If the component of force along AC is required to be 300 lb, directed from A to C , determine the magnitude of force acting along AB and the angle θ of the 500-lb force.

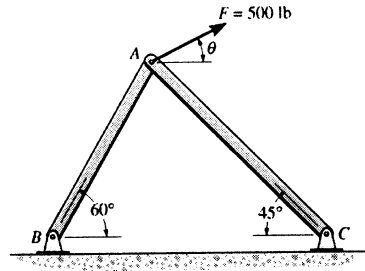

Parallelogram Law: The parallelogram law of addition is shown in Fig. (a).

Trigonometry: Using law of sines [Fig. (b)], we have

$$\frac{\sin \phi}{300} = \frac{\sin 75^\circ}{500}$$

$$\sin \phi = 0.5796$$

$$\phi = 35.42^\circ \quad \text{Ans}$$

Thus,

$$45^\circ + \theta + 75^\circ + 35.42^\circ = 180^\circ$$

$$\theta = 24.58^\circ = 24.6^\circ$$

$$\frac{F_{AB}}{\sin(45^\circ + 24.58^\circ)} = \frac{500}{\sin 75^\circ}$$

$$F_{AB} = 485 \text{ lb} \quad \text{Ans}$$

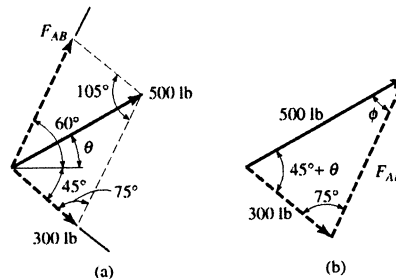

2-14. The post is to be pulled out of the ground using two ropes A and B . Rope A is subjected to a force of 600 lb and is directed at 60° from the horizontal. If the resultant force acting on the post is to be 1200 lb, vertically upward, determine the force T in rope B and the corresponding angle θ .

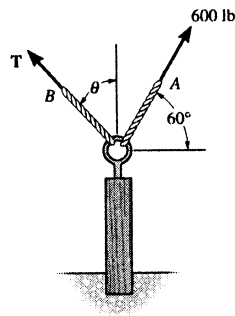

$$T = \sqrt{(600)^2 + (1200)^2 - 2(600)(1200) \cos 30^\circ}$$

$$T = 743.59 \text{ lb} = 744 \text{ lb} \quad \text{Ans}$$

$$\frac{\sin \theta}{600} = \frac{\sin 30^\circ}{743.59} \quad \theta = 23.8^\circ \quad \text{Ans}$$

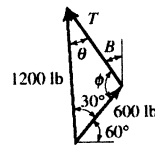

2-15. Determine the design angle θ ($0^\circ \leq \theta \leq 90^\circ$) for strut AB so that the 400-lb horizontal force has a component of 500-lb directed from A towards C . What is the component of force acting along member AB ? Take $\phi = 40^\circ$.

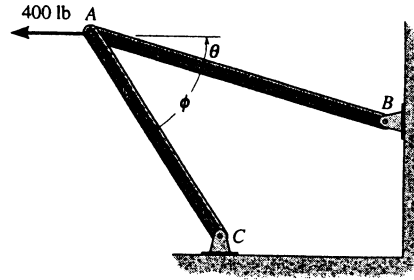

Parallelogram Law : The parallelogram law of addition is shown in Fig. (a).

Trigonometry : Using law of sines [Fig. (b)], we have

$$\frac{\sin \theta}{500} = \frac{\sin 40^\circ}{400}$$

$$\sin \theta = 0.8035$$

$$\theta = 53.46^\circ = 53.5^\circ \quad \text{Ans}$$

Thus, $\phi = 180^\circ - 40^\circ - 53.46^\circ = 86.54^\circ$

Using law of sines [Fig. (b)]

$$\frac{F_{AB}}{\sin 86.54^\circ} = \frac{400}{\sin 40^\circ}$$

$$F_{AB} = 621 \text{ lb} \quad \text{Ans}$$

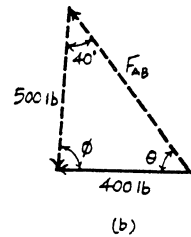
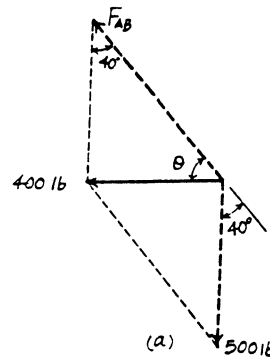

*2-16. Determine the design angle ϕ ($0^\circ \leq \phi \leq 90^\circ$) between struts AB and AC so that the 400-lb horizontal force has a component of 600-lb which acts up to the left, in the same direction as from B towards A . Take $\theta = 30^\circ$.

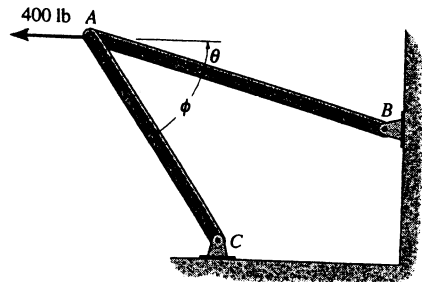

Parallelogram Law : The parallelogram law of addition is shown in Fig. (a).

Trigonometry : Using law of cosines [Fig. (b)], we have

$$F_{AC} = \sqrt{400^2 + 600^2 - 2(400)(600)\cos 30^\circ} = 322.97 \text{ lb}$$

The angle ϕ can be determined using law of sines [Fig. (b)].

$$\frac{\sin \phi}{400} = \frac{\sin 30^\circ}{322.97}$$

$$\sin \phi = 0.6193$$

$$\phi = 38.3^\circ \quad \text{Ans}$$

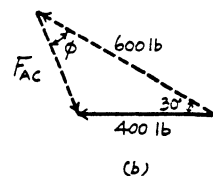
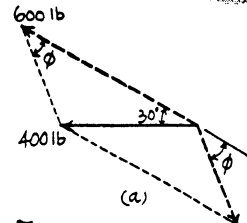

2-17. The chisel exerts a force of 20 lb on the wood dowel rod which is turning in a lathe. Resolve this force into components acting (a) along the n and y axes and (b) along the x and t axes.

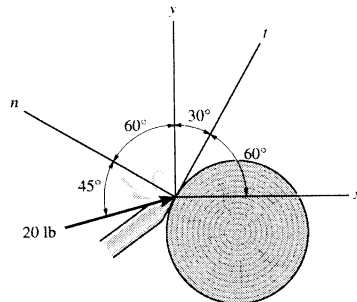

$$(a) \frac{F_y}{\sin 45^\circ} = \frac{20}{\sin 60^\circ}$$

$$F_y = 16.3 \text{ lb} \quad \text{Ans}$$

$$\frac{-F_n}{\sin 75^\circ} = \frac{20}{\sin 60^\circ}$$

$$F_n = -22.3 \text{ lb} \quad \text{Ans}$$

$$(b) \frac{F_t}{\sin 15^\circ} = \frac{20}{\sin 120^\circ}$$

$$F_t = 5.98 \text{ lb} \quad \text{Ans}$$

$$\frac{F_x}{\sin 45^\circ} = \frac{20}{\sin 120^\circ}$$

$$F_x = 16.3 \text{ lb} \quad \text{Ans}$$

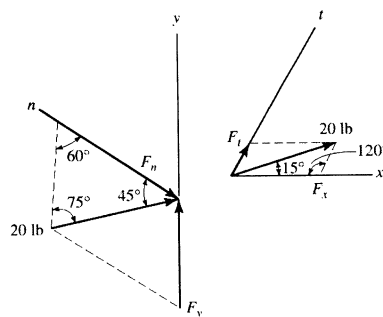

2-18. Two forces are applied at the end of a screw eye in order to remove the post. Determine the angle θ ($0^\circ \leq \theta \leq 90^\circ$) and the magnitude of force F so that the resultant force acting on the post is directed vertically upward and has a magnitude of 750 N.

Parallelogram Law: The parallelogram law of addition is shown in Fig. (a).

Trigonometry: Using law of sines [Fig. (b)], we have

$$\frac{\sin \phi}{750} = \frac{\sin 30^\circ}{500}$$

$$\sin \phi = 0.750$$

$$\phi = 131.41^\circ \quad (\text{By observation, } \phi > 90^\circ)$$

Thus,

$$\theta = 180^\circ - 30^\circ - 131.41^\circ = 18.59^\circ = 18.6^\circ \quad \text{Ans}$$

$$\frac{F}{\sin 18.59^\circ} = \frac{500}{\sin 30^\circ}$$

$$F = 319 \text{ N} \quad \text{Ans}$$

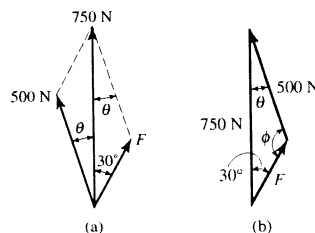
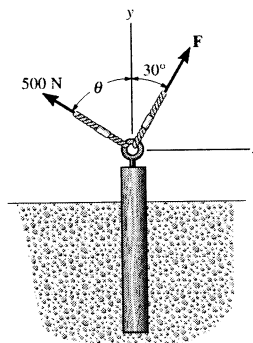

2-19. If $F_1 = F_2 = 30$ lb, determine the angles θ and ϕ so that the resultant force is directed along the positive x axis and has a magnitude of $F_R = 20$ lb.

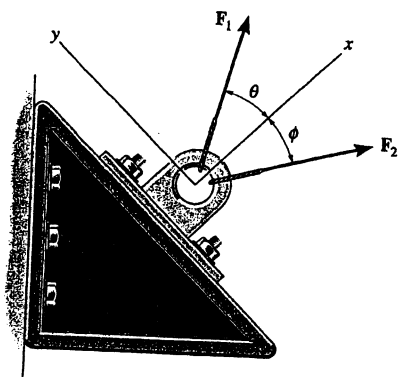

$$\frac{30}{\sin \phi} = \frac{30}{\sin \theta}$$

$$\phi = \theta$$

$$(30)^2 = (30)^2 + (20)^2 - 2(30)(20) \cos \theta$$

$$\phi = \theta = 70.5^\circ \quad \text{Ans}$$

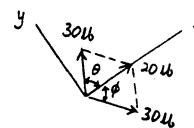

*2-20. The truck is to be towed using two ropes. Determine the magnitude of forces F_A and F_B acting on each rope in order to develop a resultant force of 950 N directed along the positive x axis. Set $\theta = 50^\circ$.

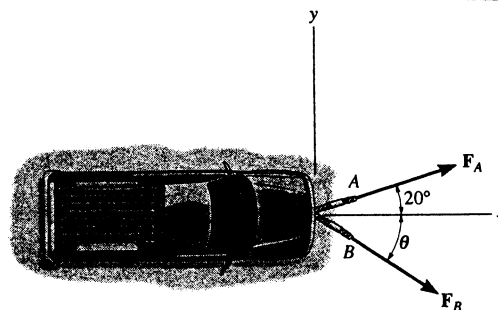

Parallelogram Law : The parallelogram law of addition is shown in Fig. (a).

Trigonometry : Using law of sines [Fig. (b)], we have

$$\frac{F_A}{\sin 50^\circ} = \frac{950}{\sin 110^\circ}$$

$$F_A = 774 \text{ N} \quad \text{Ans}$$

$$\frac{F_B}{\sin 20^\circ} = \frac{950}{\sin 110^\circ}$$

$$F_B = 346 \text{ N} \quad \text{Ans}$$

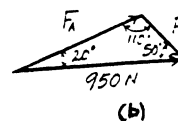
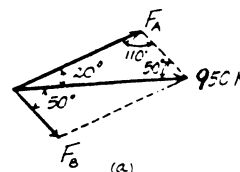

2-21. The truck is to be towed using two ropes. If the resultant force is to be 950 N, directed along the positive x axis, determine the magnitudes of forces F_A and F_B acting on each rope and the angle of θ of F_B so that the magnitude of F_B is a *minimum*. F_A acts at 20° from the x axis as shown.

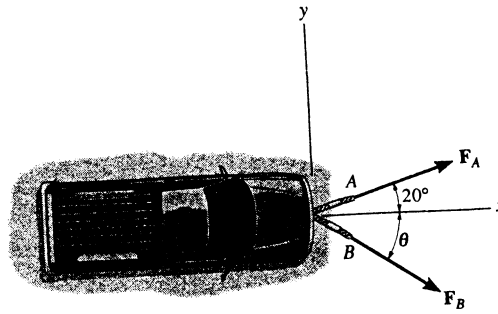

Parallelogram Law : In order to produce a *minimum* force F_B , F_B has to act perpendicular to F_A . The parallelogram law of addition is shown in Fig. (a).

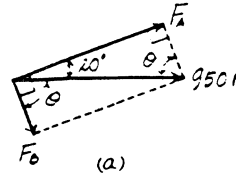

Trigonometry : Fig. (b).

$$F_B = 950 \sin 20^\circ = 325 \text{ N} \quad \text{Ans}$$

$$F_A = 950 \cos 20^\circ = 893 \text{ N} \quad \text{Ans}$$

The angle θ is

$$\theta = 90^\circ - 20^\circ = 70.0^\circ \quad \text{Ans}$$

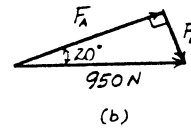

2-22. Determine the magnitude and direction of the resultant $F_R = F_1 + F_2 + F_3$ of the three forces by first finding the resultant $F' = F_1 + F_2$ and then forming $F_R = F' + F_3$.

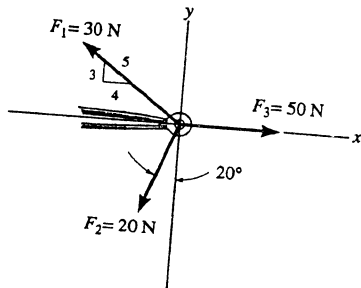

$$F' = \sqrt{(20)^2 + (30)^2 - 2(20)(30) \cos 73.13^\circ} = 30.85 \text{ N}$$

$$\frac{30.85}{\sin 73.13^\circ} = \frac{30}{\sin(70^\circ - \theta')}; \quad \theta' = 1.47^\circ$$

$$F_R = \sqrt{(30.85)^2 + (50)^2 - 2(30.85)(50) \cos 1.47^\circ} = 19.18 = 19.2 \text{ N}$$

$$\frac{19.18}{\sin 1.47^\circ} = \frac{30.85}{\sin \theta}; \quad \theta = 2.37^\circ \quad \text{Ans}$$

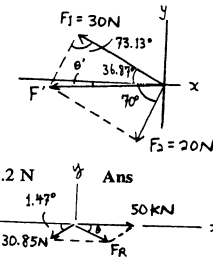

2-23. Determine the magnitude and direction of the resultant $\mathbf{F}_R = \mathbf{F}_1 + \mathbf{F}_2 + \mathbf{F}_3$ of the three forces by first finding the resultant $\mathbf{F}' = \mathbf{F}_2 + \mathbf{F}_3$ and then forming $\mathbf{F}_R = \mathbf{F}' + \mathbf{F}_1$.

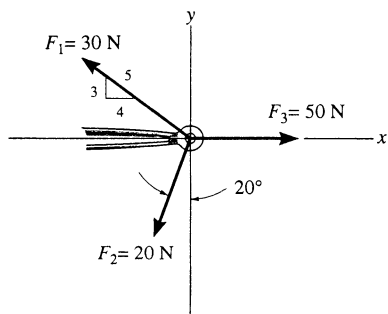

$$F' = \sqrt{(20)^2 + (50)^2 - 2(20)(50) \cos 70^\circ} = 47.07 \text{ N}$$

$$\frac{20}{\sin \theta'} = \frac{47.07}{\sin 70^\circ}; \quad \theta' = 23.53^\circ$$

$$F_R = \sqrt{(47.07)^2 + (30)^2 - 2(47.07)(30) \cos 13.34^\circ} = 19.18 = 19.2 \text{ N} \quad \text{Ans}$$

$$\frac{19.18}{\sin 13.34^\circ} = \frac{30}{\sin \phi}; \quad \phi = 21.15^\circ$$

$$\theta = 23.53^\circ - 21.15^\circ = 2.37^\circ \quad \text{Ans}$$

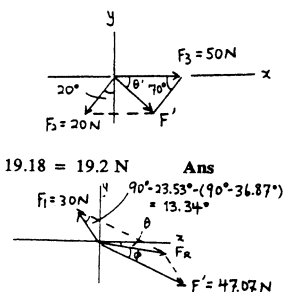

***2-24.** Resolve the 50-lb force into components acting along (a) the x and y axes, and (b) the x' and y' axes.

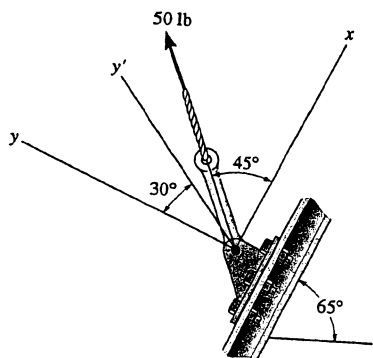

(a) $F_x = 50 \cos 45^\circ = 35.4 \text{ lb} \quad \text{Ans}$

$F_y = 50 \sin 45^\circ = 35.4 \text{ lb} \quad \text{Ans}$

(b) $\frac{F_x'}{\sin 15^\circ} = \frac{50}{\sin 120^\circ}$

$F_x' = 14.9 \text{ lb} \quad \text{Ans}$

$\frac{F_y'}{\sin 45^\circ} = \frac{50}{\sin 120^\circ}$

$F_y' = 40.8 \text{ lb} \quad \text{Ans}$

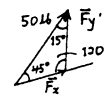
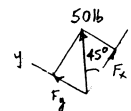

2-25. The log is being towed by two tractors A and B . Determine the magnitude of the two towing forces F_A and F_B if it is required that the resultant force have a magnitude $F_R = 10$ kN and be directed along the x axis. Set $\theta = 15^\circ$.

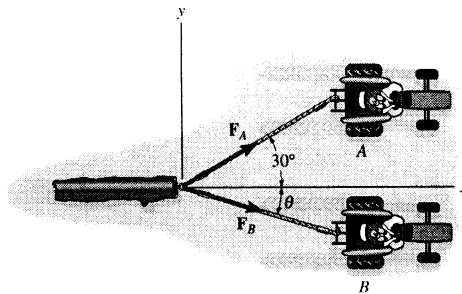

Parallelogram Law: The parallelogram law of addition is shown in Fig. (a).

Trigonometry: Using law of sines [Fig. (b)], we have

$$\frac{F_A}{\sin 15^\circ} = \frac{10}{\sin 135^\circ}$$

$$F_A = 3.66 \text{ kN} \quad \text{Ans}$$

$$\frac{F_B}{\sin 30^\circ} = \frac{10}{\sin 135^\circ}$$

$$F_B = 7.07 \text{ kN} \quad \text{Ans}$$

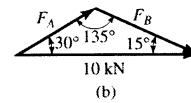
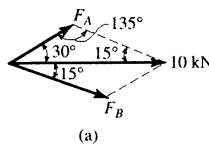

2-26. If the resultant F_R of the two forces acting on the log is to be directed along the positive x axis and have a magnitude of 10 kN, determine the angle θ of the cable, attached to B such that the force F_B in this cable is minimum. What is the magnitude of the force in each cable for this situation?

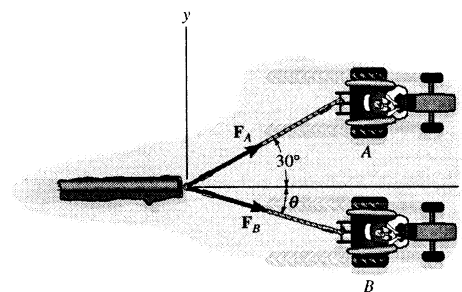

Parallelogram Law: In order to produce a *minimum* force F_B , F_B has to act perpendicular to F_A . The parallelogram law of addition is shown in Fig. (a).

Trigonometry: Fig. (b).

$$F_B = 10 \sin 30^\circ = 5.00 \text{ kN} \quad \text{Ans}$$

$$F_A = 10 \cos 30^\circ = 8.66 \text{ kN} \quad \text{Ans}$$

The angle θ is

$$\theta = 90^\circ - 30^\circ = 60.0^\circ \quad \text{Ans}$$

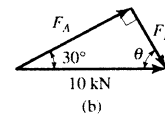
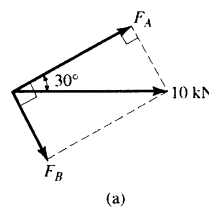

2-27. The beam is to be hoisted using two chains. Determine the magnitudes of forces F_A and F_B acting on each chain in order to develop a resultant force of 600 N directed along the positive y axis. Set $\theta = 45^\circ$.

$$\frac{F_A}{\sin 45^\circ} = \frac{600}{\sin 105^\circ}; \quad F_A = 439 \text{ N} \quad \text{Ans}$$

$$\frac{F_B}{\sin 30^\circ} = \frac{600}{\sin 105^\circ}; \quad F_B = 311 \text{ N} \quad \text{Ans}$$

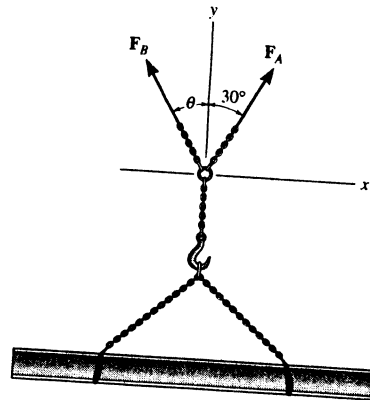
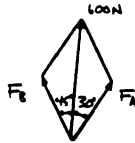

*2-28. The beam is to be hoisted using two chains. If the resultant force is to be 600 N, directed along the positive y axis, determine the magnitudes of forces F_A and F_B acting on each chain and the orientation θ of F_B so that the magnitude of F_B is a *minimum*. F_A acts at 30° from the y axis as shown.

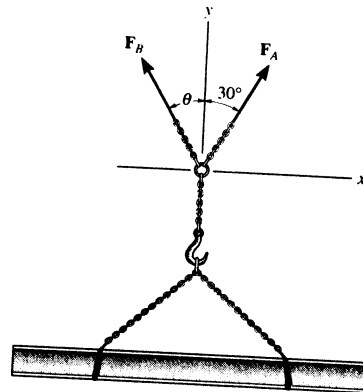

For minimum F_B , require

$$\theta = 60^\circ \quad \text{Ans}$$

$$F_A = 600 \cos 30^\circ = 520 \text{ N} \quad \text{Ans}$$

$$F_B = 600 \sin 30^\circ = 300 \text{ N} \quad \text{Ans}$$

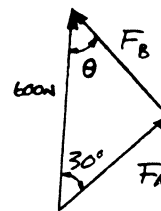

2-29. Three chains act on the bracket such that they create a resultant force having a magnitude of 500 lb. If two of the chains are subjected to known forces, as shown, determine the orientation θ of the third chain, measured clockwise from the positive x axis, so that the magnitude of force F in this chain is a *minimum*. All forces lie in the x - y plane. What is the magnitude of F ? *Hint:* First find the resultant of the two known forces. Force F acts in this direction.

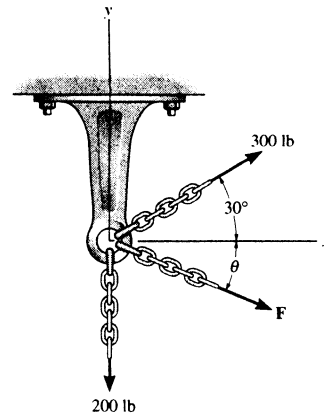

Cosine law :

$$F_{R1} = \sqrt{300^2 + 200^2 - 2(300)(200)\cos 60^\circ} = 264.6 \text{ lb}$$

Sine law :

$$\frac{\sin(30^\circ + \theta)}{200} = \frac{\sin 60^\circ}{264.6} \quad \theta = 10.9^\circ \quad \text{Ans}$$

When F is directed along F_{R1} , F will be minimum to create the resultant force.

$$\begin{aligned} F_R &= F_{R1} + F \\ 500 &= 264.6 + F_{min} \\ F_{min} &= 235 \text{ lb} \end{aligned}$$

Ans

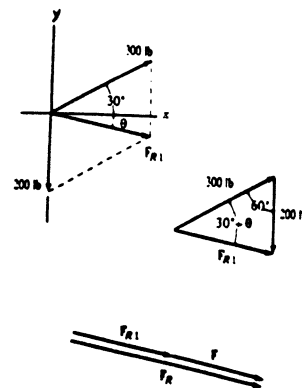

2-30. Three cables pull on the pipe such that they create a resultant force having a magnitude of 900 lb. If two of the cables are subjected to known forces, as shown in the figure, determine the direction θ of the third cable so that the magnitude of force F in this cable is a *minimum*. All forces lie in the x - y plane. What is the magnitude of F ? *Hint:* First find the resultant of the two known forces.

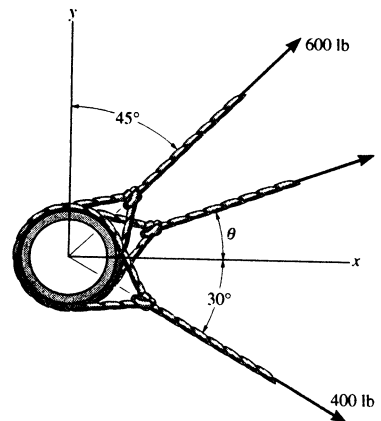

$$F' = \sqrt{(600)^2 + (400)^2 - 2(600)(400)\cos 105^\circ} = 802.64 \text{ lb}$$

$$F = 900 - 802.64 = 97.4 \text{ lb} \quad \text{Ans}$$

$$\frac{\sin \phi}{600} = \frac{\sin 105^\circ}{802.64}; \quad \phi = 46.22^\circ$$

$$\theta = 46.22^\circ - 30^\circ = 16.2^\circ \quad \text{Ans}$$

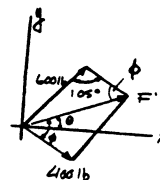

2-31. Determine the x and y components of the 800-lb force.

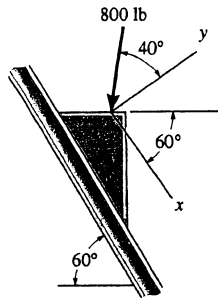

$$F_x = 800 \sin 40^\circ = 514 \text{ lb} \quad \text{Ans}$$

$$F_y = -800 \cos 40^\circ = -613 \text{ lb} \quad \text{Ans}$$

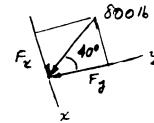

*2-32. Determine the magnitude of the resultant force and its direction, measured clockwise from the positive x axis.

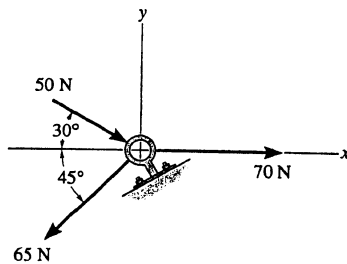

$$\rightarrow F_{R_x} = \Sigma F_x; \quad F_{R_x} = 70 + 50 \cos 30^\circ - 65 \cos 45^\circ = 67.34 \text{ N}$$

$$+ \uparrow F_{R_y} = \Sigma F_y; \quad F_{R_y} = -50 \sin 30^\circ - 65 \sin 45^\circ = -70.96 \text{ N}$$

$$F_R = \sqrt{(67.34)^2 + (-70.96)^2} = 97.8 \text{ N} \quad \text{Ans}$$

$$\theta = \tan^{-1} \frac{70.96}{67.34} = 46.5^\circ \quad \text{Ans}$$

2-33. Determine the magnitude of force F so that the resultant F_R of the three forces is as small as possible.

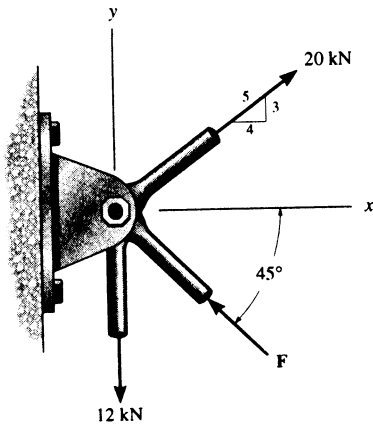

Scalar Notation : Summing the force components algebraically, we have

$$\begin{aligned} \rightarrow F_{R_x} = \Sigma F_x; \quad F_{R_x} &= 20\left(\frac{4}{5}\right) - F \cos 45^\circ \\ &= 16.0 - 0.7071F \rightarrow \end{aligned}$$

$$\begin{aligned} + \uparrow F_{R_y} = \Sigma F_y; \quad F_{R_y} &= 20\left(\frac{3}{5}\right) - 12 + F \sin 45^\circ \\ &= 0.7071F \uparrow \end{aligned}$$

The magnitude of the resultant force F_R is

$$\begin{aligned} F_R &= \sqrt{F_{R_x}^2 + F_{R_y}^2} \\ &= \sqrt{(16.0 - 0.7071F)^2 + (0.7071F)^2} \\ &= \sqrt{F^2 - 22.63F + 256} \end{aligned} \quad [1]$$

$$\begin{aligned} F_R^2 &= F^2 - 22.63F + 256 \\ 2F_R \frac{dF_R}{dF} &= 2F - 22.63 \end{aligned} \quad [2]$$

$$\left(F_R \frac{d^2 F_R}{dF^2} + \frac{dF_R}{dF} \times \frac{dF_R}{dF} \right) = 1 \quad [3]$$

In order to obtain the *minimum* resultant force F_R , $\frac{dF_R}{dF} = 0$. From Eq. [2]

$$2F_R \frac{dF_R}{dF} = 2F - 22.63 = 0$$

$$F = 11.31 \text{ kN} = 11.3 \text{ kN} \quad \text{Ans}$$

Substitute $F = 11.31 \text{ kN}$ into Eq. [1], we have

$$F_R = \sqrt{11.31^2 - 22.63(11.31) + 256} = \sqrt{128} \text{ kN}$$

Substitute $F_R = \sqrt{128} \text{ kN}$ with $\frac{dF_R}{dF} = 0$ into Eq. [3], we have

$$\begin{aligned} \left(\sqrt{128} \frac{d^2 F_R}{dF^2} + 0 \right) &= 1 \\ \frac{d^2 F_R}{dF^2} &= 0.0884 > 0 \end{aligned}$$

Hence, $F = 11.3 \text{ kN}$ is indeed producing a minimum resultant force.

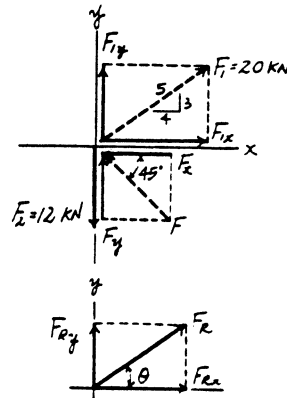

2-34. Determine the magnitude of the resultant force and its direction, measured counterclockwise from the positive x axis.

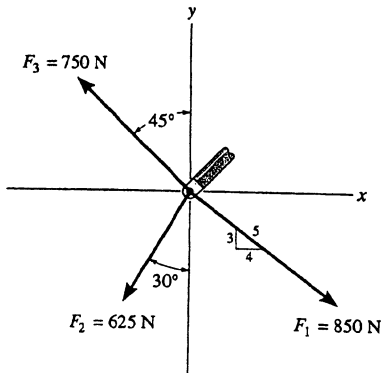

$$\rightarrow F_{Rx} = \Sigma F_x; \quad F_{Rx} = \frac{4}{5}(850) - 625 \sin 30^\circ - 750 \sin 45^\circ = -162.8 \text{ N}$$

$$+\uparrow F_{Ry} = \Sigma F_y; \quad F_{Ry} = -\frac{3}{5}(850) - 625 \cos 30^\circ + 750 \cos 45^\circ = -520.9 \text{ N}$$

$$F_R = \sqrt{(-162.8)^2 + (-520.9)^2} = 546 \text{ N} \quad \text{Ans}$$

$$\phi = \tan^{-1} \left[\frac{-520.9}{-162.8} \right] = 72.64^\circ$$

$$\theta = 180^\circ + 72.64^\circ = 253^\circ \quad \text{Ans}$$

2-35. Three forces act on the bracket. Determine the magnitude and direction θ of F_1 so that the resultant force is directed along the positive x' axis and has a magnitude of 1 kN.

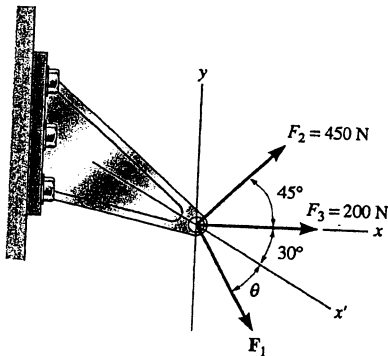

$$\rightarrow F_{Rx} = \Sigma F_x; \quad 1000 \cos 30^\circ = 200 + 450 \cos 45^\circ + F_1 \cos(\theta + 30^\circ)$$

$$+\uparrow F_{Ry} = \Sigma F_y; \quad -1000 \sin 30^\circ = 450 \sin 45^\circ - F_1 \sin(\theta + 30^\circ)$$

$$F_1 \sin(\theta + 30^\circ) = 818.198$$

$$F_1 \cos(\theta + 30^\circ) = 347.827$$

$$\theta + 30^\circ = 66.97^\circ, \quad \theta = 37.0^\circ \quad \text{Ans}$$

$$F_1 = 889 \text{ N} \quad \text{Ans}$$

*2-36. If $F_1 = 300 \text{ N}$ and $\theta = 20^\circ$, determine the magnitude and direction, measured counterclockwise from the x' axis, of the resultant force of the three forces acting on the bracket.

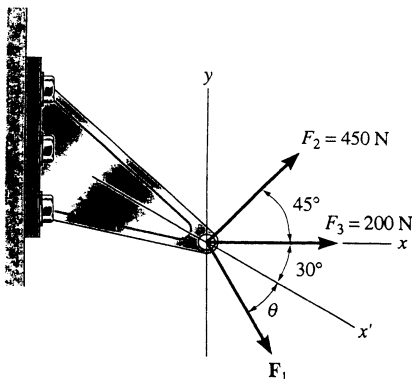

$$\rightarrow F_{Rx} = \Sigma F_x; \quad F_{Rx} = 300 \cos 50^\circ + 200 + 450 \cos 45^\circ = 711.03 \text{ N}$$

$$+\uparrow F_{Ry} = \Sigma F_y; \quad F_{Ry} = -300 \sin 50^\circ + 450 \sin 45^\circ = 88.38 \text{ N}$$

$$F_R = \sqrt{(711.03)^2 + (88.38)^2} = 717 \text{ N} \quad \text{Ans}$$

$$\phi' \text{ (angle from } x \text{ axis)} = \tan^{-1} \left[\frac{88.38}{711.03} \right]$$

$$\phi' = 7.10^\circ$$

$$\phi \text{ (angle from } x' \text{ axis)} = 30^\circ + 7.10^\circ$$

$$\phi = 37.1^\circ \quad \text{Ans}$$

2-37. Determine the magnitude and direction θ of F_1 so that the resultant force is directed vertically upward and has a magnitude of 800 N.

Scalar Notation : Summing the force components algebraically, we have

$$\begin{aligned} \rightarrow F_{R_x} = \Sigma F_x; \quad F_{R_x} = 0 &= F_1 \sin \theta + 400 \cos 30^\circ - 600 \left(\frac{4}{5}\right) \\ F_1 \sin \theta &= 133.6 \end{aligned} \quad [1]$$

$$\begin{aligned} + \uparrow F_{R_y} = \Sigma F_y; \quad F_{R_y} = 800 &= F_1 \cos \theta + 400 \sin 30^\circ + 600 \left(\frac{3}{5}\right) \\ F_1 \cos \theta &= 240 \end{aligned} \quad [2]$$

Solving Eq. [1] and [2] yields

$$\theta = 29.1^\circ \quad F_1 = 275 \text{ N} \quad \text{Ans}$$

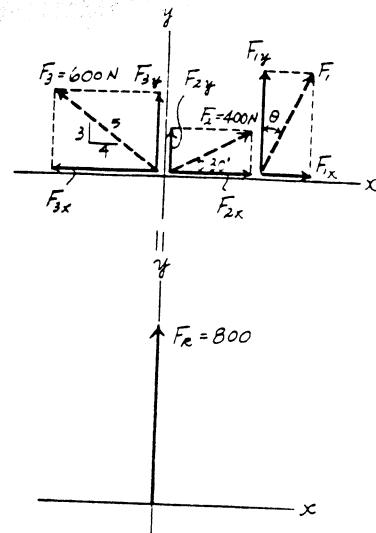
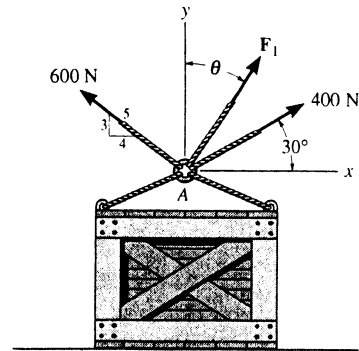

2-38. Determine the magnitude and direction measured counterclockwise from the positive x axis of the resultant force of the three forces acting on the ring A . Take $F_1 = 500$ N and $\theta = 20^\circ$.

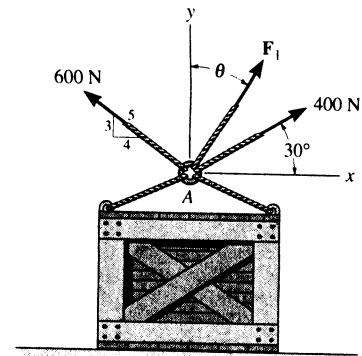

Scalar Notation : Summing the force components algebraically, we have

$$\rightarrow F_{R_x} = \Sigma F_x; \quad F_{R_x} = 500 \sin 20^\circ + 400 \cos 30^\circ - 600 \left(\frac{4}{5}\right) = 37.42 \text{ N } \rightarrow$$

$$+ \uparrow F_{R_y} = \Sigma F_y; \quad F_{R_y} = 500 \cos 20^\circ + 400 \sin 30^\circ + 600 \left(\frac{3}{5}\right) = 1029.8 \text{ N } \uparrow$$

The magnitude of the resultant force F_R is

$$F_R = \sqrt{F_{R_x}^2 + F_{R_y}^2} = \sqrt{37.42^2 + 1029.8^2} = 1030.5 \text{ N} = 1.03 \text{ kN} \quad \text{Ans}$$

The directional angle θ measured counterclockwise from positive x axis is

$$\theta = \tan^{-1} \frac{F_{R_y}}{F_{R_x}} = \tan^{-1} \left(\frac{1029.8}{37.42} \right) = 87.9^\circ \quad \text{Ans}$$

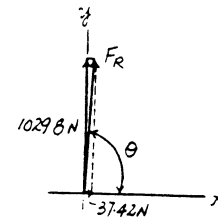
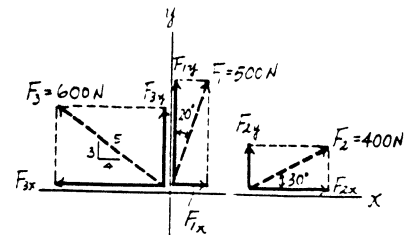

2-39. Express F_1 and F_2 as Cartesian vectors.

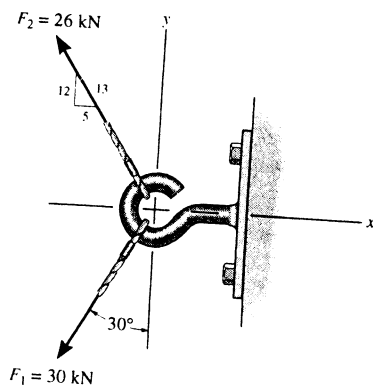

$$\begin{aligned} \mathbf{F}_1 &= -30 \sin 30^\circ \mathbf{i} - 30 \cos 30^\circ \mathbf{j} \\ &= \{-15.0 \mathbf{i} - 26.0 \mathbf{j}\} \text{ kN} \quad \text{Ans} \end{aligned}$$

$$\begin{aligned} \mathbf{F}_2 &= -\frac{5}{13}(26) \mathbf{i} + \frac{12}{13}(26) \mathbf{j} \\ &= \{-10.0 \mathbf{i} + 24.0 \mathbf{j}\} \text{ kN} \quad \text{Ans} \end{aligned}$$

*2-40. Determine the magnitude of the resultant force and its direction measured counterclockwise from the positive x axis.

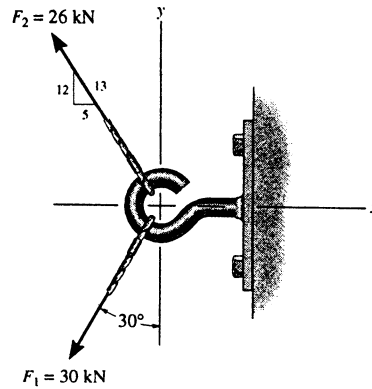

$$\rightarrow F_{Rx} = \Sigma F_x; \quad F_{Rx} = -30\sin 30^\circ - \frac{5}{13}(26) = -25 \text{ kN}$$

$$+ \uparrow F_{Ry} = \Sigma F_y; \quad F_{Ry} = -30\cos 30^\circ + \frac{12}{13}(26) = -1.981 \text{ kN}$$

$$F_R = \sqrt{(-25)^2 + (-1.981)^2} = 25.1 \text{ kN} \quad \text{Ans}$$

$$\phi = \tan^{-1}\left(\frac{1.981}{25}\right) = 4.53^\circ$$

$$\theta = 180^\circ + 4.53^\circ = 185^\circ \quad \text{Ans}$$

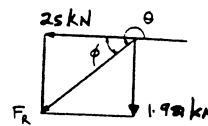

2-41. Solve Prob. 2-1 by summing the rectangular or x, y components of the forces to obtain the resultant force.

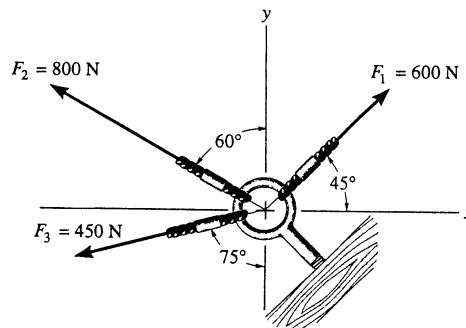

$$\rightarrow F_{Rx} = \Sigma F_x; \quad F_{Rx} = 600\cos 45^\circ - 800\sin 60^\circ = -268.556 \text{ N}$$

$$+ \uparrow F_{Ry} = \Sigma F_y; \quad F_{Ry} = 600\sin 45^\circ + 800\cos 60^\circ = 824.264 \text{ N}$$

$$F_R = \sqrt{(824.264)^2 + (-268.556)^2} = 866.91 = 867 \text{ N} \quad \text{Ans}$$

$$\theta = 180^\circ - \tan^{-1}\left(\frac{824.264}{268.556}\right)$$

$$= 180^\circ - 71.95^\circ = 108^\circ \quad \text{Ans}$$

2-42. Solve Prob. 2-22 by summing the rectangular or x, y components of the forces to obtain the resultant force.

$$F_x' = F_{1x} + F_{2x} = -30\left(\frac{4}{5}\right) - 20(\sin 20^\circ) = -30.8404$$

$$F_y' = F_{1y} + F_{2y} = 30\left(\frac{3}{5}\right) - 20(\cos 20^\circ) = -0.79385$$

$$F_{Rx} = F_x' + F_{3x} = -30.8404 + 50 = 19.1596$$

$$F_{Ry} = F_y' + F_{3y} = -0.79385 + 0 = -0.79385$$

$$F_R = \sqrt{(19.1596)^2 + (-0.79385)^2} = 19.2 \text{ N} \quad \text{Ans}$$

$$\theta = \tan^{-1}\left(\frac{-0.79385}{19.1596}\right) = -2.3726^\circ = 2.37^\circ \swarrow \quad \text{Ans}$$

2-43. Determine the magnitude and orientation θ of F_B so that the resultant force is directed along the positive y axis and has a magnitude of 1500 N.

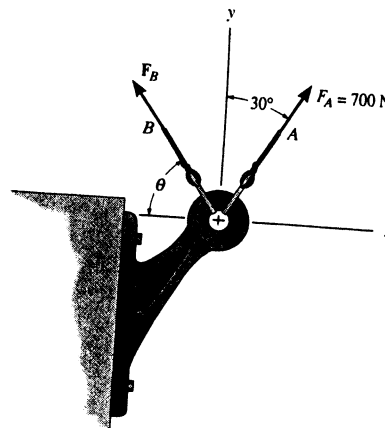

Scalar Notation : Summing the force components algebraically, we have

$$\begin{aligned} \rightarrow F_{Rx} = \Sigma F_x; \quad 0 &= 700 \sin 30^\circ - F_B \cos \theta \\ F_B \cos \theta &= 350 \end{aligned} \quad [1]$$

$$\begin{aligned} + \uparrow F_{Ry} = \Sigma F_y; \quad 1500 &= 700 \cos 30^\circ + F_B \sin \theta \\ F_B \sin \theta &= 893.8 \end{aligned} \quad [2]$$

Solving Eq. [1] and [2] yields

$$\theta = 68.6^\circ \quad F_B = 960 \text{ N} \quad \text{Ans}$$

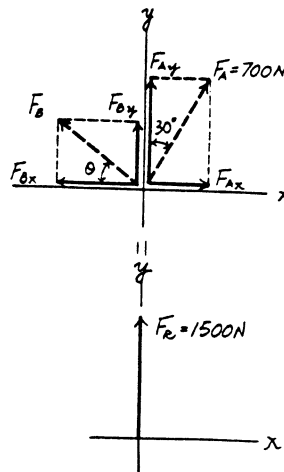

2-42. Solve Prob. 2-22 by summing the rectangular or x , y components of the forces to obtain the resultant force.

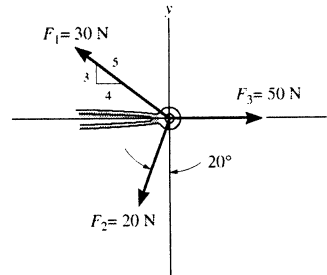

$$F'_x = F_{1x} + F_{2x} = -30\left(\frac{4}{5}\right) - 20(\sin 20^\circ) = -30.8404$$

$$F'_y = F_{1y} + F_{2y} = 30\left(\frac{3}{5}\right) - 20(\cos 20^\circ) = -0.79385$$

$$F_{Rx} = F'_x + F_{3x} = -30.8404 + 50 = 19.1596$$

$$F_{Ry} = F'_y + F_{3y} = -0.79385 + 0 = -0.79385$$

$$F_R = \sqrt{(19.1596)^2 + (-0.79385)^2} = 19.2 \text{ N} \quad \text{Ans}$$

$$\theta = \tan^{-1}\left(\frac{-0.79385}{19.1596}\right) = -2.3726^\circ = 2.37^\circ \swarrow \theta \quad \text{Ans}$$

2-43. Determine the magnitude and orientation θ of \mathbf{F}_B so that the resultant force is directed along the positive y axis and has a magnitude of 1500 N.

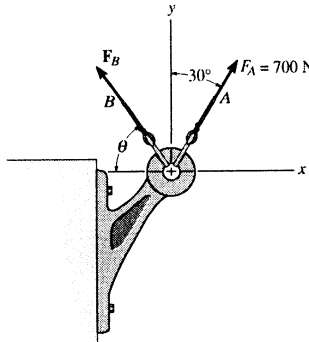

Scalar Notation: Summing the force components algebraically, we have

$$\rightarrow F_{R_x} = \Sigma F_x; \quad 0 = 700 \sin 30^\circ - F_B \cos \theta$$

$$F_B \cos \theta = 350 \quad [1]$$

$$+\uparrow F_{R_y} = \Sigma F_y; \quad 1500 = 700 \cos 30^\circ + F_B \sin \theta$$

$$F_B \sin \theta = 893.8 \quad [2]$$

Solving Eq. [1] and [2] yields

$$\theta = 68.6^\circ \quad F_B = 960 \text{ N Ans}$$

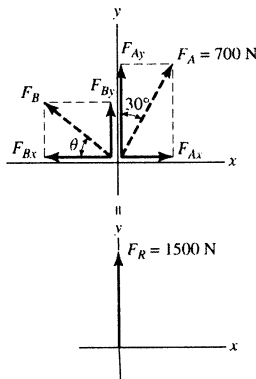

2-44. Determine the magnitude and orientation, measured counterclockwise from the positive y axis, of the resultant force acting on the bracket, if $F_B = 600$ N and $\theta = 20^\circ$.

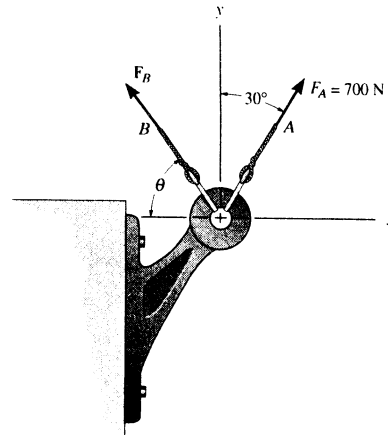

Scalar Notation : Summing the force components algebraically, we have

$$\rightarrow F_{R_x} = \Sigma F_x; \quad F_{R_x} = 700 \sin 30^\circ - 600 \cos 20^\circ = -213.8 \text{ N} = 213.8 \text{ N} \leftarrow$$

$$+ \uparrow F_{R_y} = \Sigma F_y; \quad F_{R_y} = 700 \cos 30^\circ + 600 \sin 20^\circ = 811.4 \text{ N} \uparrow$$

The magnitude of the resultant force F_R is

$$F_R = \sqrt{F_{R_x}^2 + F_{R_y}^2} = \sqrt{213.8^2 + 811.4^2} = 839 \text{ N} \quad \text{Ans}$$

The directional angle θ measured counterclockwise from positive y axis is

$$\theta = \tan^{-1} \frac{F_{R_x}}{F_{R_y}} = \tan^{-1} \left(\frac{213.8}{811.4} \right) = 14.8^\circ \quad \text{Ans}$$

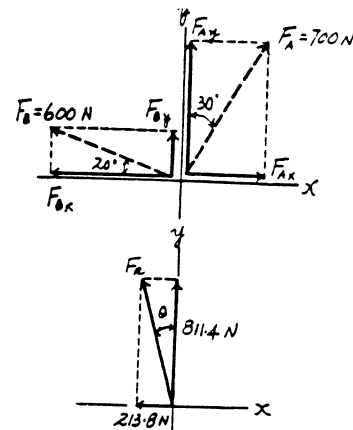

2-45. Determine the x and y components of F_1 and F_2 .

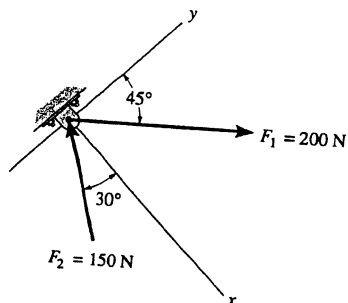

$$F_{1x} = 200 \sin 45^\circ = 141 \text{ N} \quad \text{Ans}$$

$$F_{1y} = 200 \cos 45^\circ = 141 \text{ N} \quad \text{Ans}$$

$$F_{2x} = -150 \cos 30^\circ = -130 \text{ N} \quad \text{Ans}$$

$$F_{2y} = 150 \sin 30^\circ = 75 \text{ N} \quad \text{Ans}$$

2-46. Determine the magnitude of the resultant force and its direction, measured counterclockwise from the positive x axis.

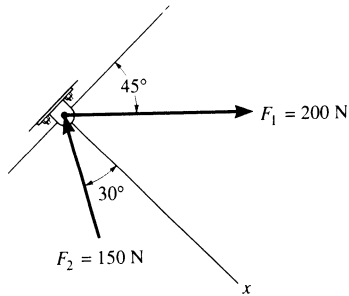

$$\rightarrow F_{Rx} = \Sigma F_x; \quad F_{Rx} = -150 \cos 30^\circ + 200 \sin 45^\circ = 11.518 \text{ N}$$

$$\uparrow F_{Ry} = \Sigma F_y; \quad F_{Ry} = 150 \sin 30^\circ + 200 \cos 45^\circ = 216.421 \text{ N}$$

$$F_R = \sqrt{(11.518)^2 + (216.421)^2} = 217 \text{ N} \quad \text{Ans}$$

$$\theta = \tan^{-1} \left(\frac{216.421}{11.518} \right) = 87.0^\circ \quad \text{Ans}$$

2-47. Determine the x and y components of each force acting on the gusset plate of the bridge truss. Show that the resultant force is zero.

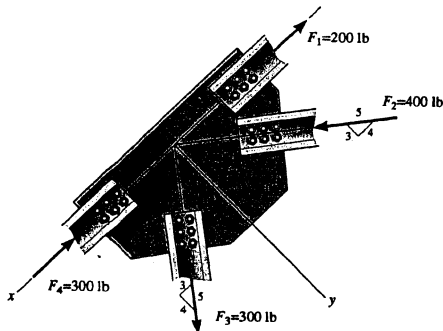

$$F_{1x} = -200 \text{ lb} \quad \text{Ans}$$

$$F_{1y} = 0 \quad \text{Ans}$$

$$F_{2x} = 400 \left(\frac{4}{5} \right) = 320 \text{ lb} \quad \text{Ans}$$

$$F_{2y} = -400 \left(\frac{3}{5} \right) = -240 \text{ lb} \quad \text{Ans}$$

$$F_{3x} = 300 \left(\frac{3}{5} \right) = 180 \text{ lb} \quad \text{Ans}$$

$$F_{3y} = 300 \left(\frac{4}{5} \right) = 240 \text{ lb} \quad \text{Ans}$$

$$F_{4x} = -300 \text{ lb} \quad \text{Ans}$$

$$F_{4y} = 0 \quad \text{Ans}$$

$$F_{Rx} = F_{1x} + F_{2x} + F_{3x} + F_{4x}$$

$$F_{Rx} = -200 + 320 + 180 - 300 = 0$$

$$F_{Ry} = F_{1y} + F_{2y} + F_{3y} + F_{4y}$$

$$F_{Ry} = 0 - 240 + 240 + 0 = 0$$

$$\text{Thus, } F_R = 0$$

*2-48. If $\theta = 60^\circ$ and $F = 20 \text{ kN}$, determine the magnitude of the resultant force and its direction measured clockwise from the positive x axis.

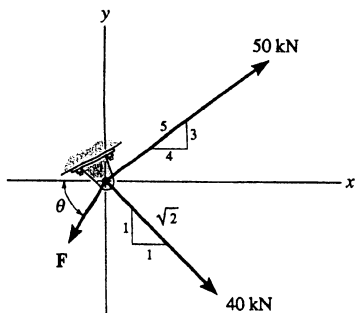

$$\rightarrow F_{Rx} = \Sigma F_x; \quad F_{Rx} = 50 \left(\frac{4}{5} \right) + \frac{1}{\sqrt{2}} (40) - 20 \cos 60^\circ = 58.28 \text{ kN}$$

$$\uparrow F_{Ry} = \Sigma F_y; \quad F_{Ry} = 50 \left(\frac{3}{5} \right) - \frac{1}{\sqrt{2}} (40) - 20 \sin 60^\circ = -15.60 \text{ kN}$$

$$F_R = \sqrt{(58.28)^2 + (-15.60)^2} = 60.3 \text{ kN} \quad \text{Ans}$$

$$\theta = \tan^{-1} \left[\frac{15.60}{58.28} \right] = 15.0^\circ \quad \text{Ans}$$

2-49. Determine the magnitude and direction θ of F_A so that the resultant force is directed along the positive x axis and has a magnitude of 1250 N.

$$\begin{aligned} \rightarrow F_{Rx} = \Sigma F_x; \quad F_{Rx} &= F_A \sin \theta + 800 \cos 30^\circ = 1250 \\ + \uparrow F_{Ry} = \Sigma F_y; \quad F_{Ry} &= F_A \cos \theta - 800 \sin 30^\circ = 0 \\ \theta &= 54.3^\circ \quad \text{Ans} \\ F_A &= 686 \text{ N} \quad \text{Ans} \end{aligned}$$

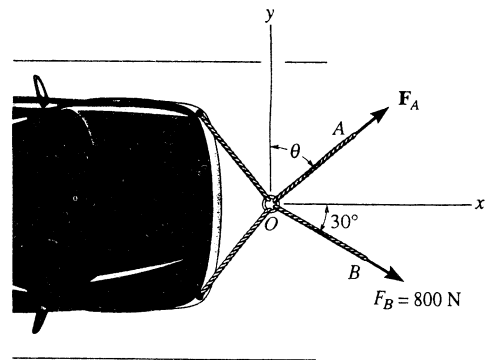

2-50. Determine the magnitude and direction, measured counterclockwise from the positive x axis, of the resultant force acting on the ring at O , if $F_A = 750 \text{ N}$ and $\theta = 45^\circ$.

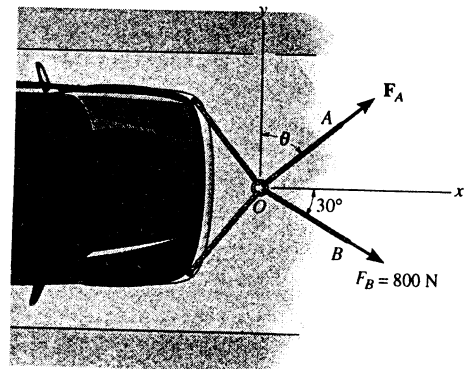

Scalar Notation : Summing the force components algebraically, we have

$$\begin{aligned} \rightarrow F_R = \Sigma F_x; \quad F_{Rx} &= 750 \sin 45^\circ + 800 \cos 30^\circ \\ &= 1223.15 \text{ N} \rightarrow \\ + \uparrow F_R = \Sigma F_y; \quad F_{Ry} &= 750 \cos 45^\circ - 800 \sin 30^\circ \\ &= 130.33 \text{ N} \uparrow \end{aligned}$$

The magnitude of the resultant force F_R is

$$\begin{aligned} F_R &= \sqrt{F_{Rx}^2 + F_{Ry}^2} \\ &= \sqrt{1223.15^2 + 130.33^2} = 1230 \text{ N} = 1.23 \text{ kN} \quad \text{Ans} \end{aligned}$$

The directional angle θ measured counterclockwise from positive x axis is

$$\theta = \tan^{-1} \frac{F_{Ry}}{F_{Rx}} = \tan^{-1} \left(\frac{130.33}{1223.15} \right) = 6.08^\circ \quad \text{Ans}$$

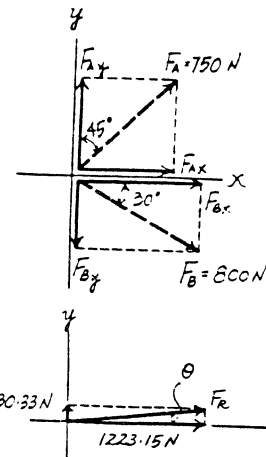

2-51. Express each of the three forces acting on the column in Cartesian vector form and compute the magnitude of the resultant force.

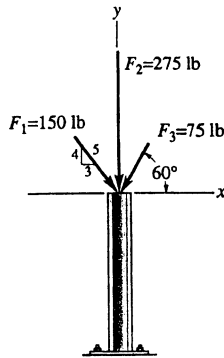

$$F_1 = 150\left(\frac{3}{5}\right)i - 150\left(\frac{4}{5}\right)j$$

$$F_1 = \{90i - 120j\} \text{ lb} \quad \text{Ans}$$

$$F_2 = \{-275j\} \text{ lb} \quad \text{Ans}$$

$$F_3 = -75 \cos 60^\circ i - 75 \sin 60^\circ j$$

$$F_3 = \{-37.5i - 65.0j\} \text{ lb} \quad \text{Ans}$$

$$F_R = \Sigma F = \{52.5i - 460j\} \text{ lb}$$

$$F_R = \sqrt{(52.5)^2 + (-460)^2} = 463 \text{ lb} \quad \text{Ans}$$

*2-52. The three concurrent forces acting on the screw eye produce a resultant force $F_R = 0$. If $F_2 = \frac{2}{3}F_1$ and F_1 is to be 90° from F_2 as shown, determine the required magnitude of F_3 expressed in terms of F_1 and the angle θ .

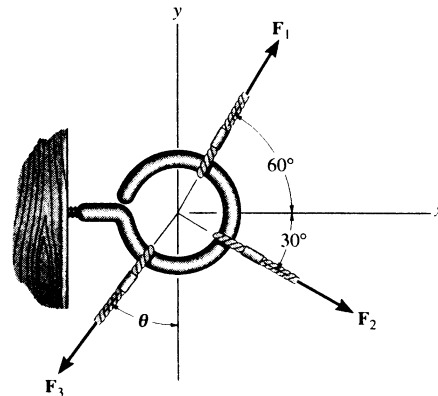

Cartesian Vector Notation :

$$F_1 = F_1 \cos 60^\circ i + F_1 \sin 60^\circ j$$

$$= 0.50F_1 i + 0.8660F_1 j$$

$$F_2 = \frac{2}{3}F_1 \cos 30^\circ i - \frac{2}{3}F_1 \sin 30^\circ j$$

$$= 0.5774F_1 i - 0.3333F_1 j$$

$$F_3 = -F_3 \sin \theta i - F_3 \cos \theta j$$

Resultant Force :

$$F_R = 0 = F_1 + F_2 + F_3$$

$$0 = (0.50F_1 + 0.5774F_1 - F_3 \sin \theta) i$$

$$+ (0.8660F_1 - 0.3333F_1 - F_3 \cos \theta) j$$

Equating i and j components, we have

$$0.50F_1 + 0.5774F_1 - F_3 \sin \theta = 0 \quad [1]$$

$$0.8660F_1 - 0.3333F_1 - F_3 \cos \theta = 0 \quad [2]$$

Solving Eq. [1] and [2] yields

$$\theta = 63.7^\circ \quad F_3 = 1.20F_1 \quad \text{Ans}$$

2-53. Determine the magnitude of force F so that the resultant F_R of the three forces is as small as possible. What is the minimum magnitude of F_R ?

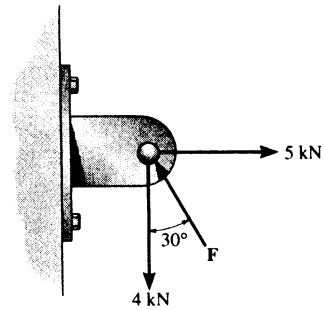

Scalar Notation : Summing the force components algebraically, we have

$$\begin{aligned} \rightarrow F_{R_x} = \Sigma F_x; \quad F_{R_x} &= 5 - F \sin 30^\circ \\ &= 5 - 0.50F \rightarrow \end{aligned}$$

$$\begin{aligned} + \uparrow F_{R_y} = \Sigma F_y; \quad F_{R_y} &= F \cos 30^\circ - 4 \\ &= 0.8660F - 4 \uparrow \end{aligned}$$

The magnitude of the resultant force F_R is

$$\begin{aligned} F_R &= \sqrt{F_{R_x}^2 + F_{R_y}^2} \\ &= \sqrt{(5 - 0.50F)^2 + (0.8660F - 4)^2} \\ &= \sqrt{F^2 - 11.93F + 41} \end{aligned} \quad [1]$$

$$\begin{aligned} F_R^2 &= F^2 - 11.93F + 41 \\ 2F_R \frac{dF_R}{dF} &= 2F - 11.93 \end{aligned} \quad [2]$$

$$\left(F_R \frac{d^2 F_R}{dF^2} + \frac{dF_R}{dF} \times \frac{dF_R}{dF} \right) = 1 \quad [3]$$

In order to obtain the *minimum* resultant force F_R , $\frac{dF_R}{dF} = 0$. From Eq.[2]

$$2F_R \frac{dF_R}{dF} = 2F - 11.93 = 0$$

$$F = 5.964 \text{ kN} = 5.96 \text{ kN} \quad \text{Ans}$$

Substituting $F = 5.964 \text{ kN}$ into Eq.[1], we have

$$\begin{aligned} F_R &= \sqrt{5.964^2 - 11.93(5.964) + 41} \\ &= 2.330 \text{ kN} = 2.33 \text{ kN} \end{aligned} \quad \text{Ans}$$

Substituting $F_R = 2.330 \text{ kN}$ with $\frac{dF_R}{dF} = 0$ into Eq.[3], we have

$$\begin{aligned} \left[(2.330) \frac{d^2 F_R}{dF^2} + 0 \right] &= 1 \\ \frac{d^2 F_R}{dF^2} &= 0.429 > 0 \end{aligned}$$

Hence, $F = 5.96 \text{ kN}$ is indeed producing a *minimum* resultant force.

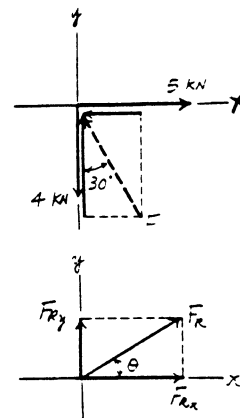

2-54. Express each of the three forces acting on the bracket in Cartesian vector form with respect to the x and y axes. Determine the magnitude and direction θ of F_1 so that the resultant force is directed along the positive x' axis and has a magnitude of $F_R = 600$ N.

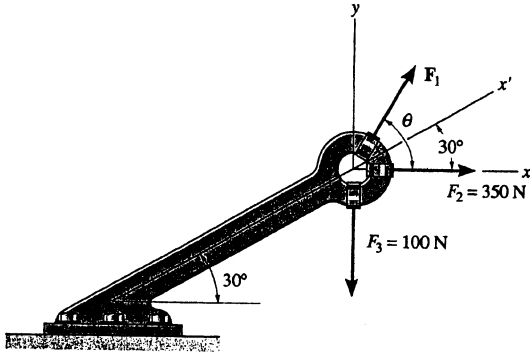

$$F_1 = \{F_1 \cos \theta \mathbf{i} + F_1 \sin \theta \mathbf{j}\} \text{ N} \quad \text{Ans}$$

$$F_2 = \{350\mathbf{i}\} \text{ N} \quad \text{Ans}$$

$$F_3 = \{-100\mathbf{j}\} \text{ N} \quad \text{Ans}$$

Require,

$$F_R = 600 \cos 30^\circ \mathbf{i} + 600 \sin 30^\circ \mathbf{j}$$

$$F_R = \{519.6\mathbf{i} + 300\mathbf{j}\} \text{ N}$$

$$F_R = \Sigma F$$

Equating the i and j components yields :

$$519.6 = F_1 \cos \theta + 350$$

$$F_1 \cos \theta = 169.6$$

$$300 = F_1 \sin \theta - 100$$

$$F_1 \sin \theta = 400$$

$$\theta = \tan^{-1} \left[\frac{400}{169.6} \right] = 67.0^\circ \quad \text{Ans}$$

$$F_1 = 434 \text{ N} \quad \text{Ans}$$

2-55. The three concurrent forces acting on the post produce a resultant force $F_R = 0$. If $F_2 = \frac{1}{2} F_1$, and F_1 is to be 90° from F_2 as shown, determine the required magnitude F_3 expressed in terms of F_1 and the angle θ .

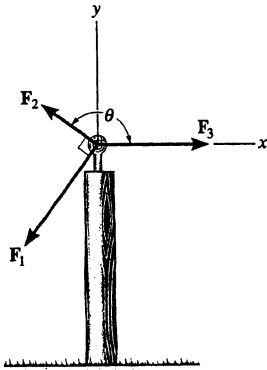

$$\Sigma F_{Rx'} = 0;$$

$$F_3 \cos(\theta - 90^\circ) = F_1$$

$$\Sigma F_{Ry'} = 0;$$

$$F_3 \sin(\theta - 90^\circ) = F_2$$

$$\tan(\theta - 90^\circ) = \frac{F_2}{F_1} = \frac{1}{2}$$

$$\theta - 90^\circ = 26.57^\circ$$

$$\theta = 116.57^\circ = 117^\circ \quad \text{Ans}$$

$$F_3 = \frac{F_1}{\cos(116.57^\circ - 90^\circ)}$$

$$F_3 = 1.12 F_1 \quad \text{Ans}$$

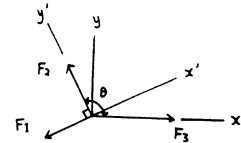

*2-56. Three forces act on the bracket. Determine the magnitude and orientation θ of F_2 so that the resultant force is directed along the positive u axis and has a magnitude of 50 lb.

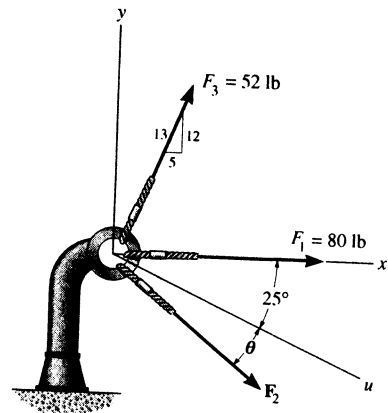

Scalar Notation : Summing the force components algebraically, we have

$$\begin{aligned} \rightarrow F_R = \Sigma F_x; \quad 50 \cos 25^\circ &= 80 + 52 \left(\frac{5}{13} \right) + F_2 \cos (25^\circ + \theta) \\ F_2 \cos (25^\circ + \theta) &= -54.684 \end{aligned} \quad [1]$$

$$\begin{aligned} + \uparrow F_R = \Sigma F_y; \quad -50 \sin 25^\circ &= 52 \left(\frac{12}{13} \right) - F_2 \sin (25^\circ + \theta) \\ F_2 \sin (25^\circ + \theta) &= 69.131 \end{aligned} \quad [2]$$

Solving Eq. [1] and [2] yields

$$25^\circ + \theta = 128.35^\circ \quad \theta = 103^\circ \quad \text{Ans}$$

$$F_2 = 88.1 \text{ lb} \quad \text{Ans}$$

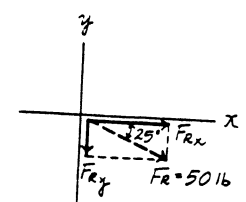
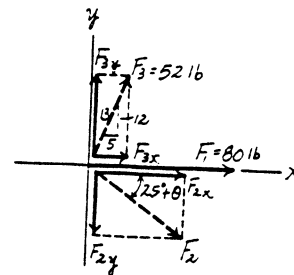

*2-57. If $F_2 = 150$ lb and $\theta = 55^\circ$, determine the magnitude and orientation, measured clockwise from the positive x axis, of the resultant force of the three forces acting on the bracket.

Scalar Notation : Summing the force components algebraically, we have

$$\begin{aligned} \rightarrow F_{R_x} = \Sigma F_x; \quad F_{R_x} &= 80 + 52\left(\frac{5}{13}\right) + 150\cos 80^\circ \\ &= 126.05 \text{ lb} \rightarrow \end{aligned}$$

$$\begin{aligned} + \uparrow F_{R_y} = \Sigma F_y; \quad F_{R_y} &= 52\left(\frac{12}{13}\right) - 150\sin 80^\circ \\ &= -99.72 \text{ lb} = 99.72 \text{ lb} \downarrow \end{aligned}$$

The magnitude of the resultant force F_R is

$$F_R = \sqrt{F_{R_x}^2 + F_{R_y}^2} = \sqrt{126.05^2 + 99.72^2} = 161 \text{ lb} \quad \text{Ans}$$

The directional angle θ measured clockwise from positive x axis is

$$\theta = \tan^{-1} \frac{F_{R_y}}{F_{R_x}} = \tan^{-1} \left(\frac{99.72}{126.05} \right) = 38.3^\circ \quad \text{Ans}$$

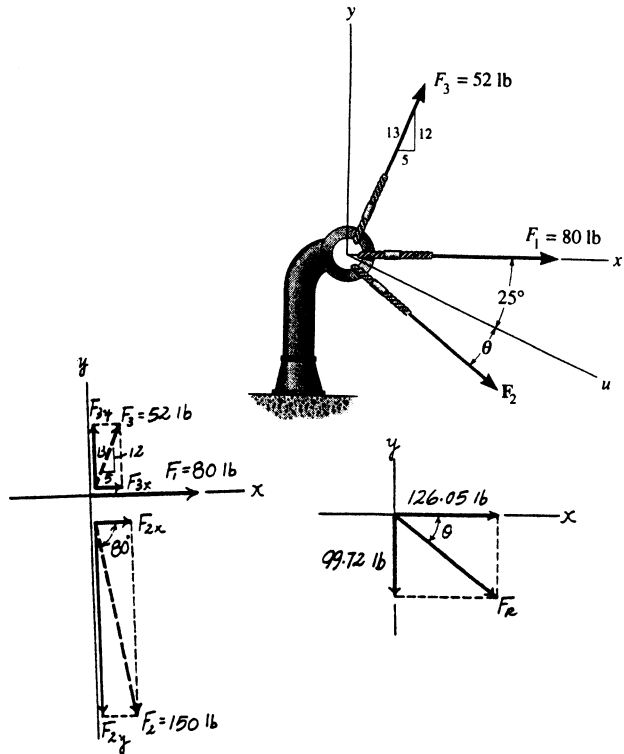

2-58. Determine the magnitude of force F so that the resultant force of the three forces is as small as possible. What is the magnitude of the resultant force?

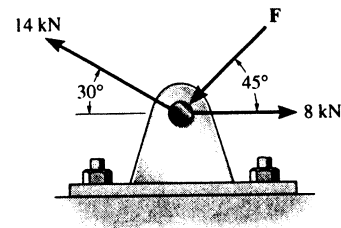

$$\begin{aligned} \rightarrow F_{R_x} = \Sigma F_x; \quad F_{R_x} &= 8 - F \cos 45^\circ - 14 \cos 30^\circ \\ &= -4.1244 - F \cos 45^\circ \end{aligned}$$

$$\begin{aligned} + \uparrow F_{R_y} = \Sigma F_y; \quad F_{R_y} &= -F \sin 45^\circ + 14 \sin 30^\circ \\ &= 7 - F \sin 45^\circ \end{aligned}$$

$$F_R^2 = (-4.1244 - F \cos 45^\circ)^2 + (7 - F \sin 45^\circ)^2 \quad (1)$$

$$2F_R \frac{dF_R}{dF} = 2(-4.1244 - F \cos 45^\circ)(-\cos 45^\circ) + 2(7 - F \sin 45^\circ)(-\sin 45^\circ) = 0$$

$$F = 2.03 \text{ kN} \quad \text{Ans}$$

From Eq. (1): $F_R = 7.87 \text{ kN} \quad \text{Ans}$

Also, from the figure require

$$(F_R)_x = 0 = \Sigma F_x; \quad F + 14 \sin 15^\circ - 8 \cos 45^\circ = 0$$

$$F = 2.03 \text{ kN} \quad \text{Ans}$$

$$(F_R)_y = \Sigma F_y; \quad F_R = 14 \cos 15^\circ - 8 \sin 45^\circ$$

$$F_R = 7.87 \text{ kN} \quad \text{Ans}$$

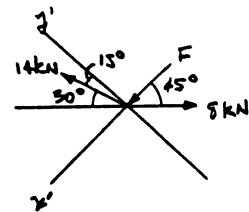
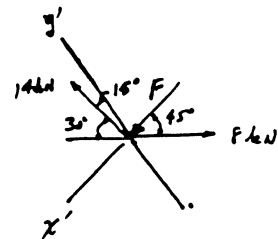

2-59. Determine the magnitude and coordinate direction angles of $F_1 = \{60\mathbf{i} - 50\mathbf{j} + 40\mathbf{k}\}$ N and $F_2 = \{-40\mathbf{i} - 85\mathbf{j} + 30\mathbf{k}\}$ N. Sketch each force on an x, y, z reference.

$$F_1 = 60\mathbf{i} - 50\mathbf{j} + 40\mathbf{k}$$

$$F_1 = \sqrt{(60)^2 + (-50)^2 + (40)^2} = 87.750 = 87.7 \text{ N} \quad \text{Ans}$$

$$\alpha_1 = \cos^{-1}\left(\frac{60}{87.750}\right) = 46.9^\circ \quad \text{Ans}$$

$$\beta_1 = \cos^{-1}\left(\frac{-50}{87.750}\right) = 125^\circ \quad \text{Ans}$$

$$\gamma_1 = \cos^{-1}\left(\frac{40}{87.750}\right) = 62.9^\circ \quad \text{Ans}$$

$$F_2 = -40\mathbf{i} - 85\mathbf{j} + 30\mathbf{k}$$

$$F_2 = \sqrt{(-40)^2 + (-85)^2 + (30)^2} = 98.615 = 98.6 \text{ N} \quad \text{Ans}$$

$$\alpha_2 = \cos^{-1}\left(\frac{-40}{98.615}\right) = 114^\circ \quad \text{Ans}$$

$$\beta_2 = \cos^{-1}\left(\frac{-85}{98.615}\right) = 150^\circ \quad \text{Ans}$$

$$\gamma_2 = \cos^{-1}\left(\frac{30}{98.615}\right) = 72.3^\circ \quad \text{Ans}$$

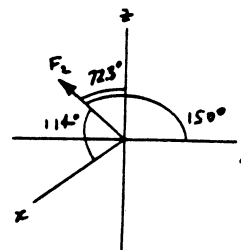

*2-60. The cable at the end of the crane boom exerts a force of 250 lb on the boom as shown. Express F as a Cartesian vector.

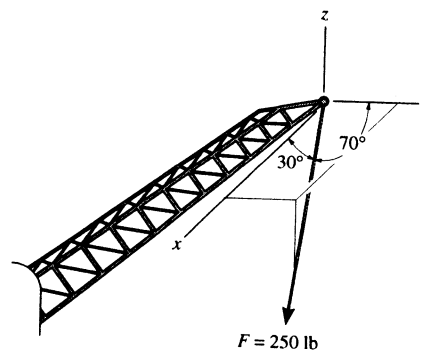

Cartesian Vector Notation: With $\alpha = 30^\circ$ and $\beta = 70^\circ$, the third coordinate direction angle γ can be determined using Eq. 2-10.

$$\begin{aligned} \cos^2 \alpha + \cos^2 \beta + \cos^2 \gamma &= 1 \\ \cos^2 30^\circ + \cos^2 70^\circ + \cos^2 \gamma &= 1 \\ \cos \gamma &= \pm 0.3647 \end{aligned}$$

$$\gamma = 68.61^\circ \text{ or } 111.39^\circ$$

By inspection, $\gamma = 111.39^\circ$ since the force F is directed in negative octant.

$$\begin{aligned} F &= 250\{\cos 30^\circ\mathbf{i} + \cos 70^\circ\mathbf{j} + \cos 111.39^\circ\mathbf{k}\} \text{ lb} \\ &= \{217\mathbf{i} + 85.5\mathbf{j} - 91.2\mathbf{k}\} \text{ lb} \quad \text{Ans} \end{aligned}$$

2-61. Determine the magnitude and coordinate direction angles of the force \mathbf{F} acting on the stake.

$$\frac{4}{5}F = 40, \quad F = 50 \text{ N}$$

$$\mathbf{F} = \left(40 \cos 70^\circ \mathbf{i} + 40 \sin 70^\circ \mathbf{j} + \frac{3}{5}(50) \mathbf{k} \right)$$

$$\mathbf{F} = \{ 13.7 \mathbf{i} + 37.6 \mathbf{j} + 30.0 \mathbf{k} \} \text{ N} \quad \text{Ans}$$

$$F = \sqrt{(13.68)^2 + (37.59)^2 + (30)^2} = 50 \text{ N} \quad \text{Ans}$$

$$\alpha = \cos^{-1}\left(\frac{13.68}{50}\right) = 74.1^\circ \quad \text{Ans}$$

$$\beta = \cos^{-1}\left(\frac{37.59}{50}\right) = 41.3^\circ \quad \text{Ans}$$

$$\gamma = \cos^{-1}\left(\frac{30}{50}\right) = 53.1^\circ \quad \text{Ans}$$

2-62. Determine the magnitude and the coordinate direction angles of the resultant force.

Cartesian Vector Notation :

$$\mathbf{F}_1 = 75 \left\{ -\frac{24}{25} \mathbf{j} + \frac{7}{25} \mathbf{k} \right\} \text{ lb} = \{-72.0 \mathbf{j} + 21.0 \mathbf{k}\} \text{ lb}$$

$$\mathbf{F}_2 = 55 \{ \cos 30^\circ \cos 60^\circ \mathbf{i} + \cos 30^\circ \sin 60^\circ \mathbf{j} - \sin 30^\circ \mathbf{k} \} \text{ lb}$$

$$= \{ 23.82 \mathbf{i} + 41.25 \mathbf{j} - 27.5 \mathbf{k} \} \text{ lb}$$

Resultant Force :

$$\mathbf{F}_R = \mathbf{F}_1 + \mathbf{F}_2$$

$$= \{ 23.82 \mathbf{i} + (-72.0 + 41.25) \mathbf{j} + (21.0 - 27.5) \mathbf{k} \} \text{ lb}$$

$$= \{ 23.82 \mathbf{i} - 30.75 \mathbf{j} - 6.50 \mathbf{k} \} \text{ lb}$$

The magnitude of the resultant force is

$$F_R = \sqrt{F_{R_x}^2 + F_{R_y}^2 + F_{R_z}^2}$$

$$= \sqrt{23.82^2 + (-30.75)^2 + (-6.50)^2}$$

$$= 39.43 \text{ lb} = 39.4 \text{ lb} \quad \text{Ans}$$

The coordinate direction angles are

$$\cos \alpha = \frac{F_{R_x}}{F_R} = \frac{23.82}{39.43} \quad \alpha = 52.8^\circ \quad \text{Ans}$$

$$\cos \beta = \frac{F_{R_y}}{F_R} = \frac{-30.75}{39.43} \quad \beta = 141^\circ \quad \text{Ans}$$

$$\cos \gamma = \frac{F_{R_z}}{F_R} = \frac{-6.50}{39.43} \quad \gamma = 99.5^\circ \quad \text{Ans}$$

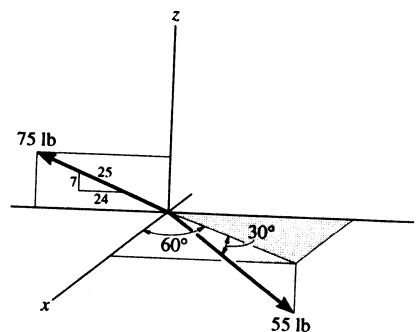

2-63. The stock S mounted on the lathe is subjected to a force of 60 N, which is caused by the die D . Determine the coordinate direction angle β and express the force as a Cartesian vector.

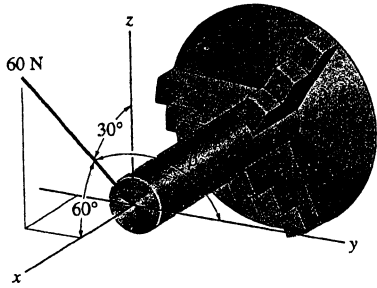

$$\cos^2 60^\circ + \cos^2 \beta + \cos^2 30^\circ = 1$$

$$\beta = 90^\circ \quad \text{Ans}$$

$$\mathbf{F} = -60(\cos 60^\circ \mathbf{i} + \cos 90^\circ \mathbf{j} + \cos 45^\circ \mathbf{k})$$

$$\mathbf{F} = \{-30\mathbf{i} - 52.0\mathbf{k}\} \text{ N} \quad \text{Ans}$$

*2-64. Determine the magnitude and coordinate direction angles of the resultant force and sketch this vector on the coordinate system.

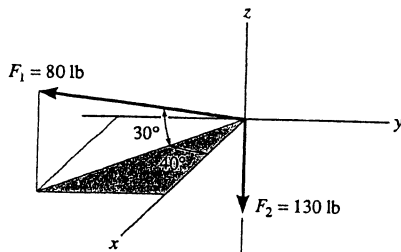

$$\mathbf{F}_1 = (80 \cos 30^\circ \cos 40^\circ \mathbf{i} - 80 \cos 30^\circ \sin 40^\circ \mathbf{j} + 80 \sin 30^\circ \mathbf{k})$$

$$\mathbf{F}_1 = \{53.1\mathbf{i} - 44.5\mathbf{j} + 40\mathbf{k}\} \text{ lb}$$

$$\mathbf{F}_2 = \{-130\mathbf{k}\} \text{ lb}$$

$$\mathbf{F}_R = \mathbf{F}_1 + \mathbf{F}_2$$

$$\mathbf{F}_R = \{53.1\mathbf{i} - 44.5\mathbf{j} - 90.0\mathbf{k}\} \text{ lb}$$

$$F_R = \sqrt{(53.1)^2 + (-44.5)^2 + (-90.0)^2} = 114 \text{ lb} \quad \text{Ans}$$

$$\alpha = \cos^{-1}\left(\frac{53.1}{113.6}\right) = 62.1^\circ \quad \text{Ans}$$

$$\beta = \cos^{-1}\left(\frac{-44.5}{113.6}\right) = 113^\circ \quad \text{Ans}$$

$$\gamma = \cos^{-1}\left(\frac{-90.0}{113.6}\right) = 142^\circ \quad \text{Ans}$$

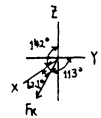

2-65. Specify the coordinate direction angles of \mathbf{F}_1 and \mathbf{F}_2 and express each force as a Cartesian vector.

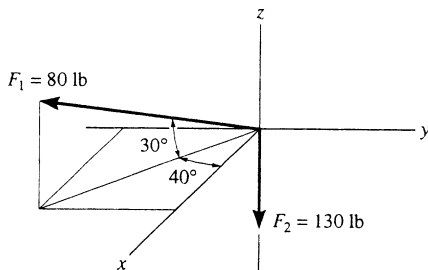

$$\mathbf{F}_1 = (80 \cos 30^\circ \cos 40^\circ \mathbf{i} - 80 \cos 30^\circ \sin 40^\circ \mathbf{j} + 80 \sin 30^\circ \mathbf{k})$$

$$\mathbf{F}_1 = \{53.1\mathbf{i} - 44.5\mathbf{j} + 40\mathbf{k}\} \text{ lb} \quad \text{Ans}$$

$$\alpha_1 = \cos^{-1}\left(\frac{53.1}{80}\right) = 48.4^\circ \quad \text{Ans}$$

$$\beta_1 = \cos^{-1}\left(\frac{-44.5}{80}\right) = 124^\circ \quad \text{Ans}$$

$$\gamma_1 = \cos^{-1}\left(\frac{40}{80}\right) = 60^\circ \quad \text{Ans}$$

$$\mathbf{F}_2 = \{-130\mathbf{k}\} \text{ lb} \quad \text{Ans}$$

$$\alpha_2 = \cos^{-1}\left(\frac{0}{130}\right) = 90^\circ \quad \text{Ans}$$

$$\beta_2 = \cos^{-1}\left(\frac{0}{130}\right) = 90^\circ \quad \text{Ans}$$

$$\gamma_2 = \cos^{-1}\left(\frac{-130}{130}\right) = 180^\circ \quad \text{Ans}$$

2-66. The mast is subjected to the three forces shown. Determine the coordinate direction angles α_1 , β_1 , γ_1 of \mathbf{F}_1 so that the resultant force acting on the mast is $\mathbf{F}_R = \{350\mathbf{i}\}$ N.

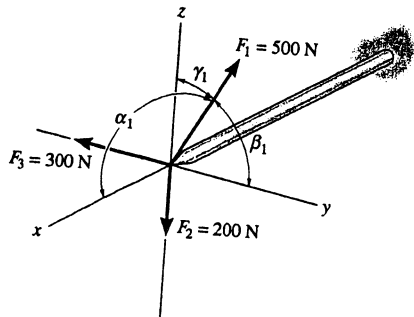

$$\mathbf{F}_1 = 500 \cos \alpha_1 \mathbf{i} + 500 \cos \beta_1 \mathbf{j} + 500 \cos \gamma_1 \mathbf{k}$$

$$\mathbf{F}_R = \mathbf{F}_1 + (-300\mathbf{j}) + (-200\mathbf{k})$$

$$350\mathbf{i} = 500 \cos \alpha_1 \mathbf{i} + (500 \cos \beta_1 - 300)\mathbf{j} + (500 \cos \gamma_1 - 200)\mathbf{k}$$

$$350 = 500 \cos \alpha_1; \quad \alpha_1 = 45.6^\circ \quad \text{Ans}$$

$$0 = 500 \cos \beta_1 - 300; \quad \beta_1 = 53.1^\circ \quad \text{Ans}$$

$$0 = 500 \cos \gamma_1 - 200; \quad \gamma_1 = 66.4^\circ \quad \text{Ans}$$

2-67. The mast is subjected to the three forces shown. Determine the coordinate direction angles α_1 , β_1 , γ_1 of \mathbf{F}_1 so that the resultant force acting on the mast is zero.

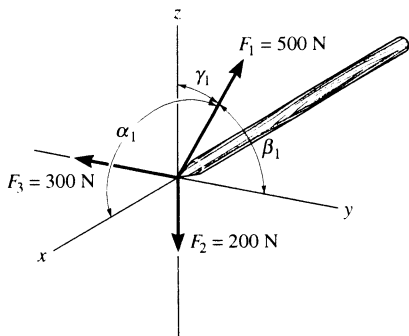

$$\mathbf{F}_1 = \{ 500 \cos \alpha_1 \mathbf{i} + 500 \cos \beta_1 \mathbf{j} + 500 \cos \gamma_1 \mathbf{k} \} \text{ N}$$

$$\mathbf{F}_2 = \{-200\mathbf{k}\} \text{ N}$$

$$\mathbf{F}_3 = \{-300\mathbf{j}\} \text{ N}$$

$$\mathbf{F}_R = \mathbf{F}_1 + \mathbf{F}_2 + \mathbf{F}_3 = \mathbf{0}$$

$$500 \cos \alpha_1 = 0; \quad \alpha_1 = 90^\circ \quad \text{Ans}$$

$$500 \cos \beta_1 = 300; \quad \beta_1 = 53.1^\circ \quad \text{Ans}$$

$$500 \cos \gamma_1 = 200; \quad \gamma_1 = 66.4^\circ \quad \text{Ans}$$

*2-68. The cables attached to the screw eye are subjected to the three forces shown. Express each force in Cartesian vector form and determine the magnitude and coordinate direction angles of the resultant force.

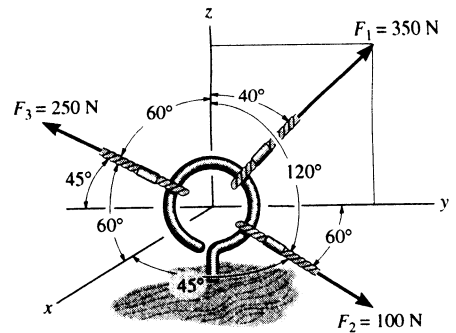

Cartesian Vector Notation :

$$\begin{aligned} \mathbf{F}_1 &= 350\{\sin 40^\circ \mathbf{j} + \cos 40^\circ \mathbf{k}\} \text{ N} \\ &= \{224.98\mathbf{j} + 268.12\mathbf{k}\} \text{ N} \\ &= \{225\mathbf{j} + 268\mathbf{k}\} \text{ N} \end{aligned}$$

Ans

$$\begin{aligned} \mathbf{F}_2 &= 100\{\cos 45^\circ \mathbf{i} + \cos 60^\circ \mathbf{j} + \cos 120^\circ \mathbf{k}\} \text{ N} \\ &= \{70.71\mathbf{i} + 50.0\mathbf{j} - 50.0\mathbf{k}\} \text{ N} \\ &= \{70.7\mathbf{i} + 50.0\mathbf{j} - 50.0\mathbf{k}\} \text{ N} \end{aligned}$$

Ans

$$\begin{aligned} \mathbf{F}_3 &= 250\{\cos 60^\circ \mathbf{i} + \cos 135^\circ \mathbf{j} + \cos 60^\circ \mathbf{k}\} \text{ N} \\ &= \{125.0\mathbf{i} - 176.78\mathbf{j} + 125.0\mathbf{k}\} \text{ N} \\ &= \{125\mathbf{i} - 177\mathbf{j} + 125\mathbf{k}\} \text{ N} \end{aligned}$$

Ans

Resultant Force :

$$\begin{aligned} \mathbf{F}_R &= \mathbf{F}_1 + \mathbf{F}_2 + \mathbf{F}_3 \\ &= \{(70.71 + 125.0)\mathbf{i} + (224.98 + 50.0 - 176.78)\mathbf{j} + (268.12 - 50.0 + 125.0)\mathbf{k}\} \text{ N} \\ &= \{195.71\mathbf{i} + 98.20\mathbf{j} + 343.12\mathbf{k}\} \text{ N} \end{aligned}$$

The magnitude of the resultant force is

$$\begin{aligned} F_R &= \sqrt{F_{R_x}^2 + F_{R_y}^2 + F_{R_z}^2} \\ &= \sqrt{195.71^2 + 98.20^2 + 343.12^2} \\ &= 407.03 \text{ N} = 407 \text{ N} \end{aligned}$$

Ans

The coordinate direction angles are

$$\cos \alpha = \frac{F_{R_x}}{F_R} = \frac{195.71}{407.03} \quad \alpha = 61.3^\circ \quad \text{Ans}$$

$$\cos \beta = \frac{F_{R_y}}{F_R} = \frac{98.20}{407.03} \quad \beta = 76.0^\circ \quad \text{Ans}$$

$$\cos \gamma = \frac{F_{R_z}}{F_R} = \frac{343.12}{407.03} \quad \gamma = 32.5^\circ \quad \text{Ans}$$

2-69. The beam is subjected to the two forces shown. Express each force in Cartesian vector form and determine the magnitude and coordinate direction angles of the resultant force.

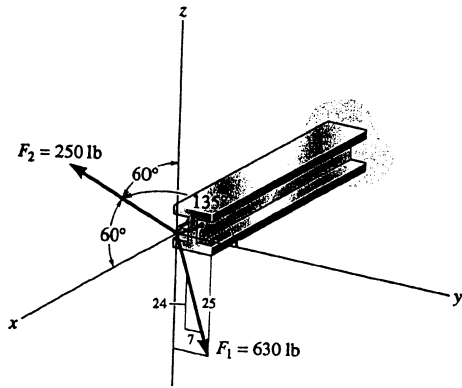

$$F_1 = 630\left(\frac{7}{25}\right)j - 630\left(\frac{24}{25}\right)k$$

$$F_1 = (176.4j - 604.8k)$$

$$F_1 = \{176j - 605k\} \text{ lb} \quad \text{Ans}$$

$$F_2 = 250 \cos 60^\circ i + 250 \cos 135^\circ j + 250 \cos 60^\circ k$$

$$F_2 = (125i - 176.777j + 125k)$$

$$F_2 = \{125i - 177j + 125k\} \text{ lb} \quad \text{Ans}$$

$$F_R = F_1 + F_2$$

$$F_R = 125i - 0.3767j - 479.8k$$

$$F_R = \{125i - 0.377j - 480k\} \text{ lb} \quad \text{Ans}$$

$$F_R = \sqrt{(125)^2 + (-0.3767)^2 + (-479.8)^2} = 495.82$$

$$= 496 \text{ lb} \quad \text{Ans}$$

$$\alpha = \cos^{-1}\left(\frac{125}{495.82}\right) = 75.4^\circ \quad \text{Ans}$$

$$\beta = \cos^{-1}\left(\frac{-0.3767}{495.82}\right) = 90.0^\circ \quad \text{Ans}$$

$$\gamma = \cos^{-1}\left(\frac{-479.8}{495.82}\right) = 165^\circ \quad \text{Ans}$$

2-70. Determine the magnitude and coordinate direction angles of the resultant force and sketch this vector on the coordinate system.

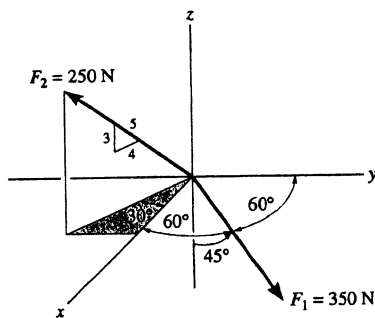

$$F_R = F_1 + F_2$$

$$F_R = 350 \cos 60^\circ i + 350 \cos 60^\circ j - 350 \cos 45^\circ k + 250\left(\frac{4}{5}\right) \cos 30^\circ i - 250\left(\frac{4}{5}\right) \sin 30^\circ j + 250\left(\frac{3}{5}\right) k$$

$$F_R = \{348.21i + 75.0j - 97.487k\} \text{ N}$$

$$F_R = \sqrt{(348.21)^2 + (75.0)^2 + (-97.487)^2}$$

$$= 369.29 = 369 \text{ N} \quad \text{Ans}$$

$$\alpha = \cos^{-1}\left(\frac{348.21}{369.29}\right) = 19.5^\circ \quad \text{Ans}$$

$$\beta = \cos^{-1}\left(\frac{75.0}{369.29}\right) = 78.3^\circ \quad \text{Ans}$$

$$\gamma = \cos^{-1}\left(\frac{-97.487}{369.29}\right) = 105^\circ \quad \text{Ans}$$

2-71. The two forces F_1 and F_2 acting at A have a resultant force of $F_R = \{-100\mathbf{k}\}$ lb. Determine the magnitude and coordinate direction angles of F_2 .

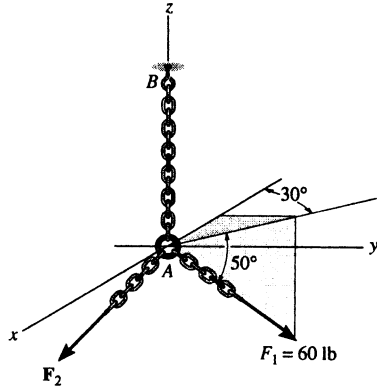

Cartesian Vector Notation :

$$F_R = \{-100\mathbf{k}\} \text{ lb}$$

$$F_1 = 60\{-\cos 50^\circ \cos 30^\circ \mathbf{i} + \cos 50^\circ \sin 30^\circ \mathbf{j} - \sin 50^\circ \mathbf{k}\} \text{ lb}$$

$$= \{-33.40\mathbf{i} + 19.28\mathbf{j} - 45.96\mathbf{k}\} \text{ lb}$$

$$F_2 = \{F_{2x}\mathbf{i} + F_{2y}\mathbf{j} + F_{2z}\mathbf{k}\} \text{ lb}$$

Resultant Force :

$$F_R = F_1 + F_2$$

$$-100\mathbf{k} = \{(F_{2x} - 33.40)\mathbf{i} + (F_{2y} + 19.28)\mathbf{j} + (F_{2z} - 45.96)\mathbf{k}\}$$

Equating i , j and k components, we have

$$F_{2x} - 33.40 = 0 \quad F_{2x} = 33.40 \text{ lb}$$

$$F_{2y} + 19.28 = 0 \quad F_{2y} = -19.28 \text{ lb}$$

$$F_{2z} - 45.96 = -100 \quad F_{2z} = -54.04 \text{ lb}$$

The magnitude of force F_2 is

$$F_2 = \sqrt{F_{2x}^2 + F_{2y}^2 + F_{2z}^2}$$

$$= \sqrt{33.40^2 + (-19.28)^2 + (-54.04)^2}$$

$$= 66.39 \text{ lb} = 66.4 \text{ lb} \quad \text{Ans}$$

The coordinate direction angles for F_2 are

$$\cos \alpha = \frac{F_{2x}}{F_2} = \frac{33.40}{66.39} \quad \alpha = 59.8^\circ \quad \text{Ans}$$

$$\cos \beta = \frac{F_{2y}}{F_2} = \frac{-19.28}{66.39} \quad \beta = 107^\circ \quad \text{Ans}$$

$$\cos \gamma = \frac{F_{2z}}{F_2} = \frac{-54.04}{66.39} \quad \gamma = 144^\circ \quad \text{Ans}$$

*2-72. Determine the coordinate direction angles of the force F_1 and indicate them on the figure.

Unit Vector For Force F_1 :

$$u_{F_1} = -\cos 50^\circ \cos 30^\circ \mathbf{i} + \cos 50^\circ \sin 30^\circ \mathbf{j} - \sin 50^\circ \mathbf{k}$$

$$= -0.5567\mathbf{i} + 0.3214\mathbf{j} - 0.7660\mathbf{k}$$

Coordinate Direction Angles : From the unit vector obtained above, we have

$$\cos \alpha = -0.5567 \quad \alpha = 124^\circ \quad \text{Ans}$$

$$\cos \beta = 0.3214 \quad \beta = 71.3^\circ \quad \text{Ans}$$

$$\cos \gamma = -0.7660 \quad \gamma = 140^\circ \quad \text{Ans}$$

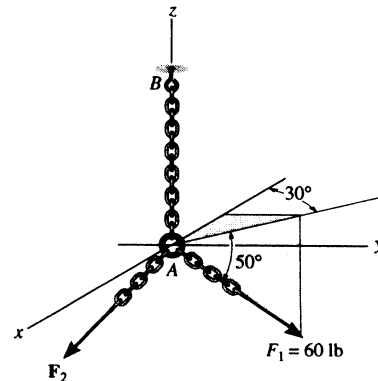

2-73. The bracket is subjected to the two forces shown. Express each force in Cartesian vector form and then determine the resultant force \mathbf{F}_R . Find the magnitude and coordinate direction angles of the resultant force.

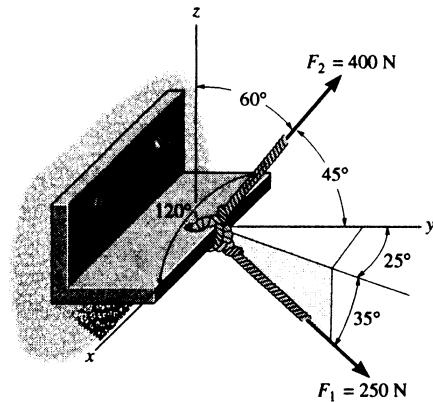

Cartesian Vector Notation :

$$\begin{aligned} \mathbf{F}_1 &= 250 \{ \cos 35^\circ \sin 25^\circ \mathbf{i} + \cos 35^\circ \cos 25^\circ \mathbf{j} - \sin 35^\circ \mathbf{k} \} \text{ N} \\ &= \{ 86.55\mathbf{i} + 185.60\mathbf{j} - 143.39\mathbf{k} \} \text{ N} \\ &= \{ 86.5\mathbf{i} + 186\mathbf{j} - 143\mathbf{k} \} \text{ N} \end{aligned} \quad \text{Ans}$$

$$\begin{aligned} \mathbf{F}_2 &= 400 \{ \cos 120^\circ \mathbf{i} + \cos 45^\circ \mathbf{j} + \cos 60^\circ \mathbf{k} \} \text{ N} \\ &= \{ -200.0\mathbf{i} + 282.84\mathbf{j} + 200.0\mathbf{k} \} \text{ N} \\ &= \{ -200\mathbf{i} + 283\mathbf{j} + 200\mathbf{k} \} \text{ N} \end{aligned} \quad \text{Ans}$$

Resultant Force :

$$\begin{aligned} \mathbf{F}_R &= \mathbf{F}_1 + \mathbf{F}_2 \\ &= \{ (86.55 - 200.0)\mathbf{i} + (185.60 + 282.84)\mathbf{j} + (-143.39 + 200.0)\mathbf{k} \} \\ &= \{ -113.45\mathbf{i} + 468.44\mathbf{j} + 56.61\mathbf{k} \} \text{ N} \\ &= \{ -113\mathbf{i} + 468\mathbf{j} + 56.6\mathbf{k} \} \text{ N} \end{aligned} \quad \text{Ans}$$

The magnitude of the resultant force is

$$\begin{aligned} F_R &= \sqrt{F_{R_x}^2 + F_{R_y}^2 + F_{R_z}^2} \\ &= \sqrt{(-113.45)^2 + 468.44^2 + 56.61^2} \\ &= 485.30 \text{ N} = 485 \text{ N} \end{aligned} \quad \text{Ans}$$

The coordinate direction angles are

$$\begin{aligned} \cos \alpha &= \frac{F_{R_x}}{F_R} = \frac{-113.45}{485.30} & \alpha &= 104^\circ & \text{Ans} \\ \cos \beta &= \frac{F_{R_y}}{F_R} = \frac{468.44}{485.30} & \beta &= 15.1^\circ & \text{Ans} \\ \cos \gamma &= \frac{F_{R_z}}{F_R} = \frac{56.61}{485.30} & \gamma &= 83.3^\circ & \text{Ans} \end{aligned}$$

2-74. The pole is subjected to the force \mathbf{F} , which has components acting along the x , y , z axes as shown. If the magnitude of \mathbf{F} is 3 kN, and $\beta = 30^\circ$ and $\gamma = 75^\circ$, determine the magnitudes of its three components.

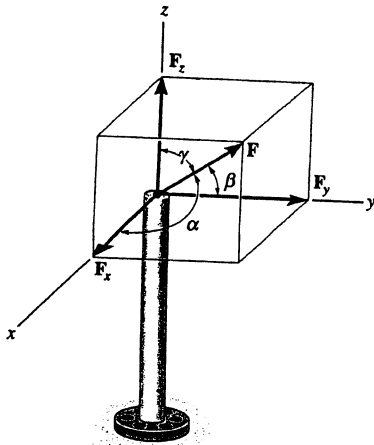

$$\cos^2 \alpha + \cos^2 \beta + \cos^2 \gamma = 1$$

$$\cos^2 \alpha + \cos^2 30^\circ + \cos^2 75^\circ = 1$$

$$\alpha = 64.67^\circ$$

$$F_x = 3 \cos 64.67^\circ = 1.28 \text{ kN} \quad \text{Ans}$$

$$F_y = 3 \cos 30^\circ = 2.60 \text{ kN} \quad \text{Ans}$$

$$F_z = 3 \cos 75^\circ = 0.776 \text{ kN} \quad \text{Ans}$$

2-75. The pole is subjected to the force F which has components $F_x = 1.5$ kN and $F_z = 1.25$ kN. If $\beta = 75^\circ$, determine the magnitudes of F and F_y .

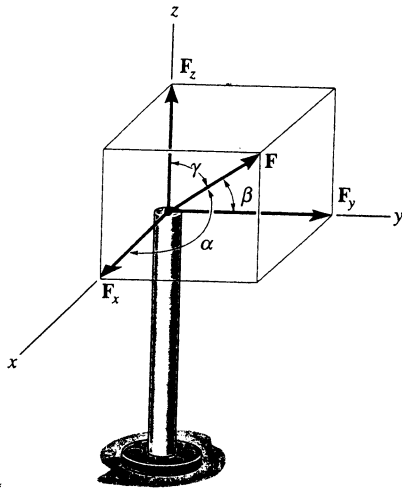

$$\cos^2 \alpha + \cos^2 \beta + \cos^2 \gamma = 1$$

$$\left(\frac{1.5}{F}\right)^2 + \cos^2 75^\circ + \left(\frac{1.25}{F}\right)^2 = 1$$

$$F = 2.02 \text{ kN} \quad \text{Ans}$$

$$F_y = 2.02 \cos 75^\circ = 0.523 \text{ kN} \quad \text{Ans}$$

*2-76. A force F is applied at the top of the tower at A . If it acts in the direction shown such that one of its components lying in the shaded y - z plane has a magnitude of 80 lb, determine its magnitude F and coordinate direction angles α , β , γ .

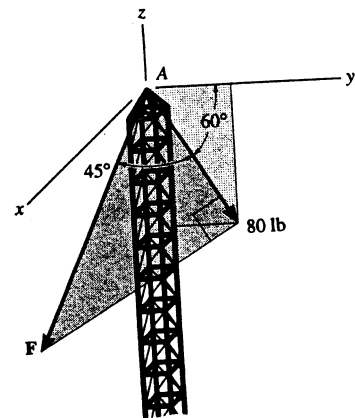

Cartesian Vector Notation : The magnitude of force F is

$$F \cos 45^\circ = 80 \quad F = 113.14 \text{ lb} = 113 \text{ lb} \quad \text{Ans}$$

Thus,

$$\begin{aligned} \mathbf{F} &= (113.14 \sin 45^\circ \mathbf{i} + 80 \cos 60^\circ \mathbf{j} - 80 \sin 60^\circ \mathbf{k}) \text{ lb} \\ &= (80.0 \mathbf{i} + 40.0 \mathbf{j} - 69.28 \mathbf{k}) \text{ lb} \end{aligned}$$

The coordinate direction angles are

$$\cos \alpha = \frac{F_x}{F} = \frac{80.0}{113.14} \quad \alpha = 45.0^\circ \quad \text{Ans}$$

$$\cos \beta = \frac{F_y}{F} = \frac{40.0}{113.14} \quad \beta = 69.3^\circ \quad \text{Ans}$$

$$\cos \gamma = \frac{F_z}{F} = \frac{-69.28}{113.14} \quad \gamma = 128^\circ \quad \text{Ans}$$

2-77. Three forces act on the hook. If the resultant force F_R has a magnitude and direction as shown, determine the magnitude and the coordinate direction angles of force F_3 .

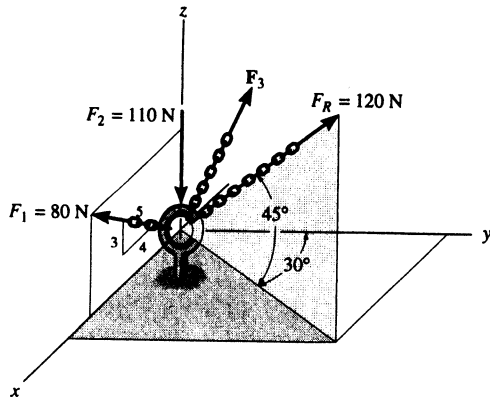

Cartesian Vector Notation :

$$F_R = 120\{\cos 45^\circ \sin 30^\circ \mathbf{i} + \cos 45^\circ \cos 30^\circ \mathbf{j} + \sin 45^\circ \mathbf{k}\} \text{ N}$$

$$= \{42.43\mathbf{i} + 73.48\mathbf{j} + 84.85\mathbf{k}\} \text{ N}$$

$$F_1 = 80\left\{\frac{4}{5}\mathbf{i} + \frac{3}{5}\mathbf{k}\right\} \text{ N} = \{64.0\mathbf{i} + 48.0\mathbf{k}\} \text{ N}$$

$$F_2 = \{-110\mathbf{k}\} \text{ N}$$

$$F_3 = \{F_{3x}\mathbf{i} + F_{3y}\mathbf{j} + F_{3z}\mathbf{k}\} \text{ N}$$

Resultant Force :

$$F_R = F_1 + F_2 + F_3$$

$$\{42.43\mathbf{i} + 73.48\mathbf{j} + 84.85\mathbf{k}\}$$

$$= \{(64.0 + F_{3x})\mathbf{i} + F_{3y}\mathbf{j} + (48.0 - 110 + F_{3z})\mathbf{k}\}$$

Equating i, j and k components, we have

$$64.0 + F_{3x} = 42.43 \quad F_{3z} = -21.57 \text{ N}$$

$$F_{3y} = 73.48 \text{ N}$$

$$48.0 - 110 + F_{3z} = 84.85 \quad F_{3x} = 146.85 \text{ N}$$

The magnitude of force F_3 is

$$F_3 = \sqrt{F_{3x}^2 + F_{3y}^2 + F_{3z}^2}$$

$$= \sqrt{(-21.57)^2 + 73.48^2 + 146.85^2}$$

$$= 165.62 \text{ N} = 166 \text{ N} \quad \text{Ans}$$

The coordinate direction angles for F_3 are

$$\cos \alpha = \frac{F_{3x}}{F_3} = \frac{-21.57}{165.62} \quad \alpha = 97.5^\circ \quad \text{Ans}$$

$$\cos \beta = \frac{F_{3y}}{F_3} = \frac{73.48}{165.62} \quad \beta = 63.7^\circ \quad \text{Ans}$$

$$\cos \gamma = \frac{F_{3z}}{F_3} = \frac{146.85}{165.62} \quad \gamma = 27.5^\circ \quad \text{Ans}$$

2-78. Determine the coordinate direction angles of F_1 and F_R .

Unit Vector of F_1 and F_R :

$$u_{F_1} = \frac{4}{5}\mathbf{i} + \frac{3}{5}\mathbf{k} = 0.8\mathbf{i} + 0.6\mathbf{k}$$

$$u_R = \cos 45^\circ \sin 30^\circ \mathbf{i} + \cos 45^\circ \cos 30^\circ \mathbf{j} + \sin 45^\circ \mathbf{k}$$

$$= 0.3536\mathbf{i} + 0.6124\mathbf{j} + 0.7071\mathbf{k}$$

Thus, the coordinate direction angles F_1 and F_R are

$$\cos \alpha_{F_1} = 0.8 \quad \alpha_{F_1} = 36.9^\circ \quad \text{Ans}$$

$$\cos \beta_{F_1} = 0 \quad \beta_{F_1} = 90.0^\circ \quad \text{Ans}$$

$$\cos \gamma_{F_1} = 0.6 \quad \gamma_{F_1} = 53.1^\circ \quad \text{Ans}$$

$$\cos \alpha_R = 0.3536 \quad \alpha_R = 69.3^\circ \quad \text{Ans}$$

$$\cos \beta_R = 0.6124 \quad \beta_R = 52.2^\circ \quad \text{Ans}$$

$$\cos \gamma_R = 0.7071 \quad \gamma_R = 45.0^\circ \quad \text{Ans}$$

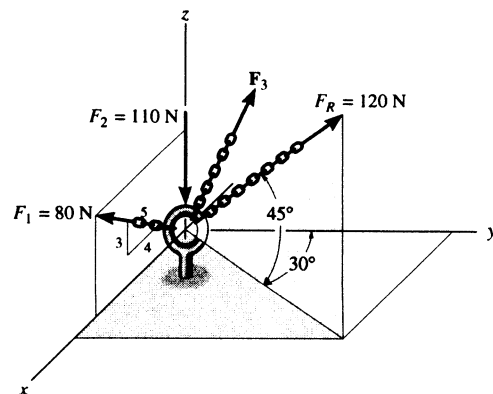

2-79. The bolt is subjected to the force F , which has components acting along the x , y , z axes as shown. If the magnitude of F is 80 N, and $\alpha = 60^\circ$ and $\gamma = 45^\circ$, determine the magnitudes of its components.

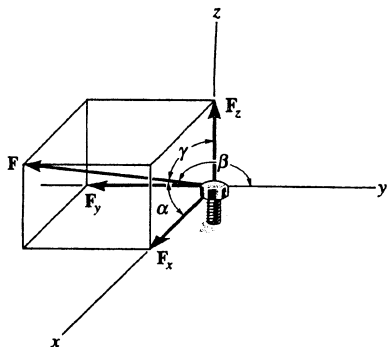

$$\begin{aligned}\cos \beta &= \sqrt{1 - \cos^2 \alpha - \cos^2 \gamma} \\ &= \sqrt{1 - \cos^2 60^\circ - \cos^2 45^\circ}\end{aligned}$$

$$\beta = 120^\circ$$

$$F_x = |80 \cos 60^\circ| = 40 \text{ N} \quad \text{Ans}$$

$$F_y = |80 \cos 120^\circ| = 40 \text{ N} \quad \text{Ans}$$

$$F_z = |80 \cos 45^\circ| = 56.6 \text{ N} \quad \text{Ans}$$

*2-80. Two forces F_1 and F_2 act on the bolt. If the resultant force F_R has a magnitude of 50 lb and coordinate direction angles $\alpha = 110^\circ$ and $\beta = 80^\circ$, as shown, determine the magnitude of F_2 and its coordinate direction angles.

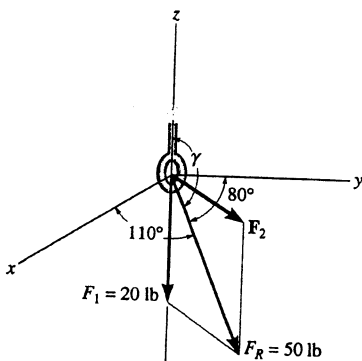

$$(1)^2 = \cos^2 110^\circ + \cos^2 80^\circ + \cos^2 \gamma$$

$$\gamma = 157.44^\circ$$

$$F_R = F_1 + F_2$$

$$50 \cos 110^\circ = (F_2)_x$$

$$50 \cos 80^\circ = (F_2)_y$$

$$50 \cos 157.44^\circ = (F_2)_z - 20$$

$$(F_2)_x = -17.10$$

$$(F_2)_y = 8.68$$

$$(F_2)_z = -26.17$$

$$F_2 = \sqrt{(-17.10)^2 + (8.68)^2 + (-26.17)^2} = 32.4 \text{ lb} \quad \text{Ans}$$

$$\alpha_2 = \cos^{-1}\left(\frac{-17.10}{32.4}\right) = 122^\circ \quad \text{Ans}$$

$$\beta_2 = \cos^{-1}\left(\frac{8.68}{32.4}\right) = 74.5^\circ \quad \text{Ans}$$

$$\gamma_2 = \cos^{-1}\left(\frac{-26.17}{32.4}\right) = 144^\circ \quad \text{Ans}$$

2-81. If $\mathbf{r}_1 = \{3\mathbf{i} - 4\mathbf{j} + 3\mathbf{k}\}$ m, $\mathbf{r}_2 = \{4\mathbf{i} - 5\mathbf{k}\}$ m, $\mathbf{r}_3 = \{3\mathbf{i} - 2\mathbf{j} + 5\mathbf{k}\}$ m, determine the magnitude and direction of $\mathbf{r} = 2\mathbf{r}_1 - \mathbf{r}_2 + 3\mathbf{r}_3$.

$$\begin{aligned}\mathbf{r} &= 2\mathbf{r}_1 - \mathbf{r}_2 + 3\mathbf{r}_3 \\ &= 6\mathbf{i} - 8\mathbf{j} + 6\mathbf{k} - 4\mathbf{i} + 5\mathbf{k} + 9\mathbf{i} - 6\mathbf{j} + 15\mathbf{k} \\ &= 11\mathbf{i} - 14\mathbf{j} + 26\mathbf{k}\end{aligned}$$

$$r = \sqrt{(11)^2 + (-14)^2 + (26)^2} = 31.51 \text{ m} = 31.5 \text{ m} \quad \text{Ans}$$

$$\mathbf{u}_r = \frac{11}{31.51}\mathbf{i} - \frac{14}{31.51}\mathbf{j} + \frac{26}{31.51}\mathbf{k}$$

$$\alpha = \cos^{-1}\left(\frac{11}{31.51}\right) = 69.6^\circ \quad \text{Ans}$$

$$\beta = \cos^{-1}\left(\frac{-14}{31.51}\right) = 116^\circ \quad \text{Ans}$$

$$\gamma = \cos^{-1}\left(\frac{26}{31.51}\right) = 34.4^\circ \quad \text{Ans}$$

2-82. Represent the position vector \mathbf{r} acting from point $A(3 \text{ m}, 5 \text{ m}, 6 \text{ m})$ to point $B(5 \text{ m}, -2 \text{ m}, 1 \text{ m})$ in Cartesian vector form. Determine its coordinate direction angles and find the distance between points A and B .

Position Vector : This can be established from the coordinates of two points.

$$\begin{aligned}\mathbf{r}_{AB} &= \{(5-3)\mathbf{i} + (-2-5)\mathbf{j} + (1-6)\mathbf{k}\} \text{ ft} \\ &= \{2\mathbf{i} - 7\mathbf{j} - 5\mathbf{k}\} \text{ ft} \quad \text{Ans}\end{aligned}$$

The distance between point A and B is

$$r_{AB} = \sqrt{2^2 + (-7)^2 + (-5)^2} = \sqrt{78} \text{ ft} = 8.83 \text{ ft} \quad \text{Ans}$$

The coordinate direction angles are

$$\cos \alpha = \frac{2}{\sqrt{78}} \quad \alpha = 76.9^\circ \quad \text{Ans}$$

$$\cos \beta = \frac{-7}{\sqrt{78}} \quad \beta = 142^\circ \quad \text{Ans}$$

$$\cos \gamma = \frac{-5}{\sqrt{78}} \quad \gamma = 124^\circ \quad \text{Ans}$$

2-83. A position vector extends from the origin to point $A(2 \text{ m}, 3 \text{ m}, 6 \text{ m})$. Determine the angles α , β , γ which the tail of the vector makes with the x , y , z axes, respectively.

Position Vector : This can be established from the coordinates of two points.

$$\mathbf{r} = \{2\mathbf{i} + 3\mathbf{j} + 6\mathbf{k}\} \text{ ft} \quad \text{Ans}$$

The distance between point A and B is

$$r_{AB} = \sqrt{2^2 + (3)^2 + (6)^2} = 7 \text{ ft} \quad \text{Ans}$$

The coordinate direction angles are

$$\cos \alpha = \frac{2}{7} \quad \alpha = 73.4^\circ \quad \text{Ans}$$

$$\cos \beta = \frac{3}{7} \quad \beta = 64.6^\circ \quad \text{Ans}$$

$$\cos \gamma = \frac{6}{7} \quad \gamma = 31.0^\circ \quad \text{Ans}$$

2-82. Represent the position vector r acting from point $A(3 \text{ m}, 5 \text{ m}, 6 \text{ m})$ to point $B(5 \text{ m}, -2 \text{ m}, 1 \text{ m})$ in Cartesian vector form. Determine its coordinate direction angles and find the distance between points A and B .

Position Vector: This can be established from the coordinates of two points.

$$\begin{aligned} r_{AB} &= \{(5 - 3)\mathbf{i} + (-2 - 5)\mathbf{j} + (1 - 6)\mathbf{k}\} \text{ft} \\ &= \{2\mathbf{i} - 7\mathbf{j} - 5\mathbf{k}\} \text{ft} \quad \text{Ans} \end{aligned}$$

The distance between point A and B is

$$r_{AB} = \sqrt{2^2 + (-7)^2 + (-5)^2} = \sqrt{78} \text{ ft} = 8.83 \text{ ft} \quad \text{Ans}$$

The coordinate direction angles are

$$\cos \alpha = \frac{2}{\sqrt{78}} \quad \alpha = 76.9^\circ \quad \text{Ans}$$

$$\cos \beta = \frac{-7}{\sqrt{78}} \quad \beta = 142^\circ \quad \text{Ans}$$

$$\cos \gamma = \frac{-5}{\sqrt{78}} \quad \gamma = 124^\circ \quad \text{Ans}$$

2-83. A position vector extends from the origin to point $A(2 \text{ m}, 3 \text{ m}, 6 \text{ m})$. Determine the angles α , β , γ which the tail of the vector makes with the x , y , z axes, respectively.

Position Vector: This can be established from the coordinates of two points.

$$\mathbf{r} = \{2\mathbf{i} + 3\mathbf{j} + 6\mathbf{k}\} \text{ ft} \quad \text{Ans}$$

The distance between point A and B is

$$r_{AB} = \sqrt{2^2 + (3)^2 + (6)^2} = 7 \text{ ft} \quad \text{Ans}$$

The coordinate direction angles are

$$\cos \alpha = \frac{2}{7} \quad \alpha = 73.4^\circ \quad \text{Ans}$$

$$\cos \beta = \frac{3}{7} \quad \beta = 64.6^\circ \quad \text{Ans}$$

$$\cos \gamma = \frac{6}{7} \quad \gamma = 31.0^\circ \quad \text{Ans}$$

*2-84. Express the position vector r in Cartesian vector form; then determine its magnitude and coordinate direction angles.

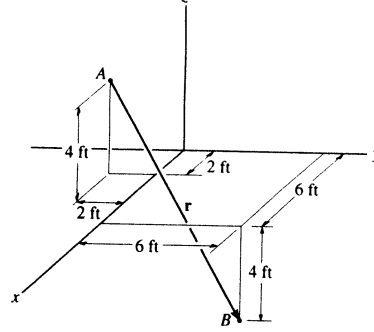

Position Vector :

$$r = \{(6-2)\mathbf{i} + [6-(-2)]\mathbf{j} + (-4-4)\mathbf{k}\} \text{ ft}$$

$$= \{4\mathbf{i} + 8\mathbf{j} - 8\mathbf{k}\} \text{ ft} \quad \text{Ans}$$

The magnitude of r is

$$r = \sqrt{4^2 + 8^2 + (-8)^2} = 12.0 \text{ ft} \quad \text{Ans}$$

The coordinate direction angles are

$$\cos \alpha = \frac{4}{12.0} \quad \alpha = 70.5^\circ \quad \text{Ans}$$

$$\cos \beta = \frac{8}{12.0} \quad \beta = 48.2^\circ \quad \text{Ans}$$

$$\cos \gamma = \frac{-8}{12.0} \quad \gamma = 132^\circ \quad \text{Ans}$$

2-85. Express the position vector r in Cartesian vector form; then determine its magnitude and coordinate direction angles.

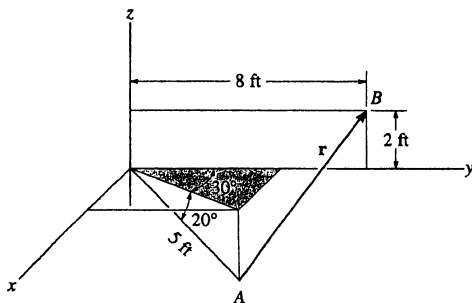

$$r = (-5 \cos 20^\circ \sin 30^\circ \mathbf{i} + (8 - 5 \cos 20^\circ \cos 30^\circ) \mathbf{j} + (2 + 5 \sin 20^\circ) \mathbf{k})$$

$$r = \{-2.35\mathbf{i} + 3.93\mathbf{j} + 3.71\mathbf{k}\} \text{ ft} \quad \text{Ans}$$

$$r = \sqrt{(-2.35)^2 + (3.93)^2 + (3.71)^2} = 5.89 \text{ ft} \quad \text{Ans}$$

$$\alpha = \cos^{-1}\left(\frac{-2.35}{5.89}\right) = 113^\circ \quad \text{Ans}$$

$$\beta = \cos^{-1}\left(\frac{3.93}{5.89}\right) = 48.2^\circ \quad \text{Ans}$$

$$\gamma = \cos^{-1}\left(\frac{3.71}{5.89}\right) = 51.0^\circ \quad \text{Ans}$$

2-86. Express force F as a Cartesian vector; then determine its coordinate direction angles.

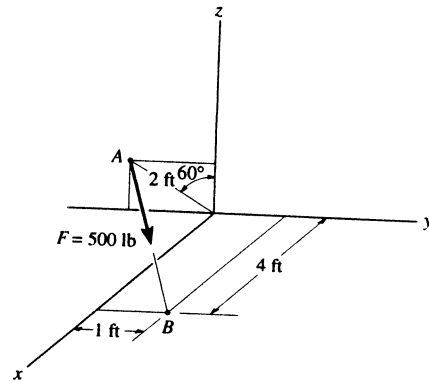

Unit Vector :

$$\begin{aligned} \mathbf{r}_{AB} &= \{(4-0)\mathbf{i} + [1 - (-2\sin 60^\circ)]\mathbf{j} + (0 - 2\cos 60^\circ)\mathbf{k}\} \text{ ft} \\ &= \{4.00\mathbf{i} + 2.732\mathbf{j} - 1.00\mathbf{k}\} \text{ ft} \end{aligned}$$

$$r_{AB} = \sqrt{4.00^2 + 2.732^2 + (-1.00)^2} = 4.946 \text{ ft}$$

$$\begin{aligned} \mathbf{u}_{AB} &= \frac{\mathbf{r}_{AB}}{r_{AB}} = \frac{4.00\mathbf{i} + 2.732\mathbf{j} - 1.00\mathbf{k}}{4.946} \\ &= 0.8087\mathbf{i} + 0.5524\mathbf{j} - 0.2022\mathbf{k} \end{aligned}$$

Force Vector :

$$\begin{aligned} \mathbf{F} &= F\mathbf{u}_{AB} = 500\{0.8087\mathbf{i} + 0.5524\mathbf{j} - 0.2022\mathbf{k}\} \text{ lb} \\ &= \{404\mathbf{i} + 276\mathbf{j} - 101\mathbf{k}\} \text{ lb} \end{aligned} \quad \text{Ans}$$

Coordinate Direction Angles : From the unit vector \mathbf{u}_{AB} obtained above, we have

$$\begin{array}{lll} \cos \alpha = 0.8087 & \alpha = 36.0^\circ & \text{Ans} \\ \cos \beta = 0.5524 & \beta = 56.5^\circ & \text{Ans} \\ \cos \gamma = -0.2022 & \gamma = 102^\circ & \text{Ans} \end{array}$$

2-87. Determine the length of member AB of the truss by first establishing a Cartesian position vector from A to B and then determining its magnitude.

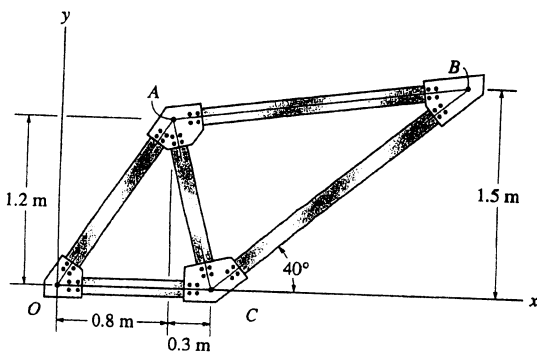

$$\mathbf{r}_{AB} = (1.1 + \frac{1.5}{\tan 40^\circ} - 0.8)\mathbf{i} + (1.5 - 1.2)\mathbf{j}$$

$$\mathbf{r}_{AB} = \{2.09\mathbf{i} + 0.3\mathbf{j}\} \text{ m}$$

$$r_{AB} = \sqrt{(2.09)^2 + (0.3)^2} = 2.11 \text{ m} \quad \text{Ans}$$

***2-88.** At a given instant, the position of a plane at A and a train at B are measured relative to a radar antenna at O . Determine the distance d between A and B at this instant. To solve the problem, formulate a position vector, directed from A to B , and then determine its magnitude.

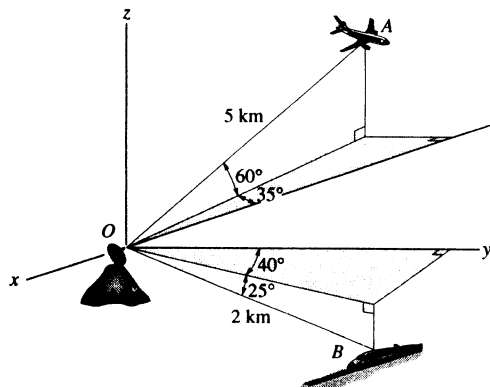

Position Vector: The coordinates of points A and B are

$$A(-5\cos 60^\circ \cos 35^\circ, -5\cos 60^\circ \sin 35^\circ, 5\sin 60^\circ) \text{ km}$$

$$= A(-2.048, -1.434, 4.330) \text{ km}$$

$$B(2\cos 25^\circ \sin 40^\circ, 2\cos 25^\circ \cos 40^\circ, -2\sin 25^\circ) \text{ km}$$

$$= B(1.165, 1.389, -0.845) \text{ km}$$

The position vector r_{AB} can be established from the coordinates of points A and B .

$$r_{AB} = \{[1.165 - (-2.048)]i + [1.389 - (-1.434)]j + [-0.845 - 4.330]k\} \text{ km}$$

$$= \{3.213i + 2.822j - 5.175k\} \text{ km}$$

The distance between points A and B is

$$d = r_{AB} = \sqrt{3.213^2 + 2.822^2 + (-5.175)^2} = 6.71 \text{ km} \quad \text{Ans}$$

2-89. The hinged plate is supported by the cord AB . If the force in the cord is $F = 340$ lb, express this force, directed from A toward B , as a Cartesian vector. What is the length of the cord?

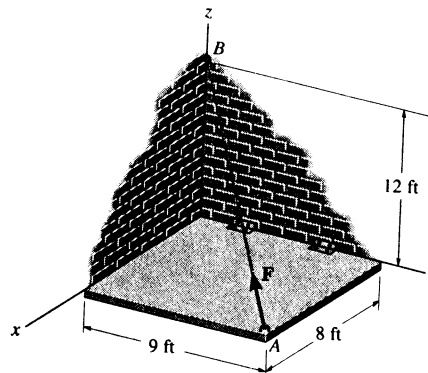

Unit Vector:

$$r_{AB} = \{(0-9)i + (0-8)j + (12-0)k\} \text{ ft}$$

$$= \{-9i - 8j + 12k\} \text{ ft}$$

$$r_{AB} = \sqrt{(-9)^2 + (-8)^2 + 12^2} = 17.0 \text{ ft} \quad \text{Ans}$$

$$u_{AB} = \frac{r_{AB}}{r_{AB}} = \frac{-9i - 8j + 12k}{17} = -\frac{9}{17}i - \frac{8}{17}j + \frac{12}{17}k$$

Force Vector:

$$F = Fu_{AB} = 340 \left\{ -\frac{9}{17}i - \frac{8}{17}j + \frac{12}{17}k \right\} \text{ lb}$$

$$= \{-180i - 160j + 240k\} \text{ lb} \quad \text{Ans}$$

2-90. Determine the length of the crankshaft AB by first formulating a Cartesian position vector from A to B and then determining its magnitude.

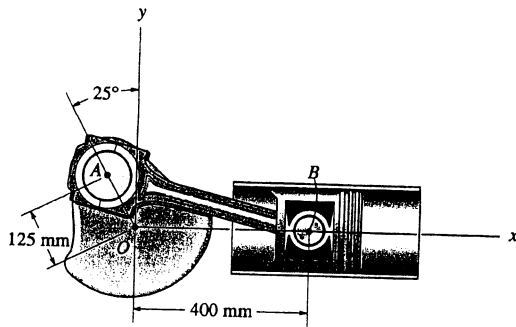

$$\mathbf{r}_{AB} = ((400 + 125\sin 25^\circ)\mathbf{i} - 125\cos 25^\circ\mathbf{j})$$

$$\mathbf{r}_{AB} = \{452.83\mathbf{i} - 113.3\mathbf{j}\} \text{ mm}$$

$$r_{AB} = \sqrt{(452.83)^2 + (-113.3)^2} = 467 \text{ mm}$$

Ans

2-91. Determine the lengths of wires AD , BD , and CD . The ring at D is midway between A and B .

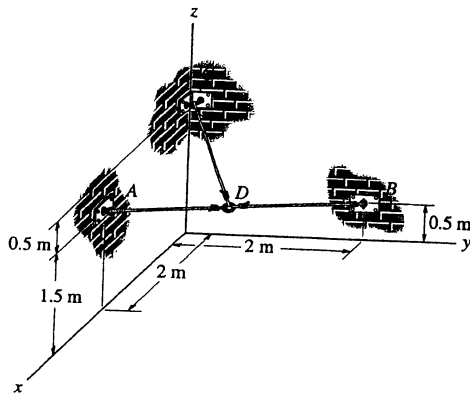

$$D\left(\frac{2+0}{2}, \frac{0+2}{2}, \frac{1.5+0.5}{2}\right) \text{ m} = D(1, 1, 1) \text{ m}$$

$$\begin{aligned} \mathbf{r}_{AD} &= (1-2)\mathbf{i} + (1-0)\mathbf{j} + (1-1.5)\mathbf{k} \\ &= -1\mathbf{i} + 1\mathbf{j} - 0.5\mathbf{k} \end{aligned}$$

$$\begin{aligned} \mathbf{r}_{BD} &= (1-0)\mathbf{i} + (1-2)\mathbf{j} + (1-0.5)\mathbf{k} \\ &= 1\mathbf{i} - 1\mathbf{j} + 0.5\mathbf{k} \end{aligned}$$

$$\begin{aligned} \mathbf{r}_{CD} &= (1-0)\mathbf{i} + (1-0)\mathbf{j} + (1-2)\mathbf{k} \\ &= 1\mathbf{i} + 1\mathbf{j} - 1\mathbf{k} \end{aligned}$$

$$r_{AD} = \sqrt{(-1)^2 + 1^2 + (-0.5)^2} = 1.50 \text{ m} \quad \text{Ans}$$

$$r_{BD} = \sqrt{1^2 + (-1)^2 + 0.5^2} = 1.50 \text{ m} \quad \text{Ans}$$

$$r_{CD} = \sqrt{1^2 + 1^2 + (-1)^2} = 1.73 \text{ m} \quad \text{Ans}$$

***2-92.** Express force \mathbf{F} as a Cartesian vector; then determine its coordinate direction angles.

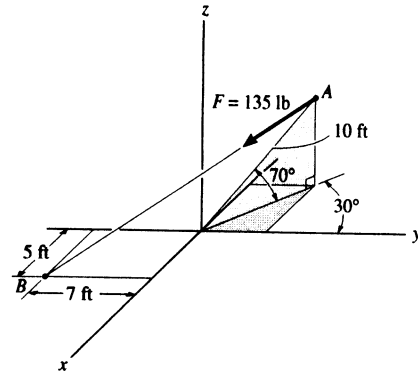

Unit Vector : The coordinates of point A are

$$A(-10 \cos 70^\circ \sin 30^\circ, 10 \cos 70^\circ \cos 30^\circ, 10 \sin 70^\circ) \text{ ft}$$

$$= A(-1.710, 2.962, 9.397) \text{ ft}$$

Then

$$\mathbf{r}_{AB} = \{[5 - (-1.710)]\mathbf{i} + (-7 - 2.962)\mathbf{j} + (0 - 9.397)\mathbf{k}\} \text{ ft}$$

$$= \{6.710\mathbf{i} - 9.962\mathbf{j} - 9.397\mathbf{k}\} \text{ ft}$$

$$r_{AB} = \sqrt{6.710^2 + (-9.962)^2 + (-9.397)^2} = 15.250 \text{ ft}$$

$$\mathbf{u}_{AB} = \frac{\mathbf{r}_{AB}}{r_{AB}} = \frac{6.710\mathbf{i} - 9.962\mathbf{j} - 9.397\mathbf{k}}{15.250}$$

$$= 0.4400\mathbf{i} - 0.6532\mathbf{j} - 0.6162\mathbf{k}$$

Force Vector :

$$\mathbf{F} = F\mathbf{u}_{AB} = 135\{0.4400\mathbf{i} - 0.6532\mathbf{j} - 0.6162\mathbf{k}\} \text{ lb}$$

$$= \{59.4\mathbf{i} - 88.2\mathbf{j} - 83.2\mathbf{k}\} \text{ lb} \quad \text{Ans}$$

Coordinate Direction Angles : From the unit vector \mathbf{u}_{AB} obtained above, we have

| | | |
|-------------------------|-----------------------|------------|
| $\cos \alpha = 0.4400$ | $\alpha = 63.9^\circ$ | Ans |
| $\cos \beta = -0.6532$ | $\beta = 131^\circ$ | Ans |
| $\cos \gamma = -0.6162$ | $\gamma = 128^\circ$ | Ans |

2-93. Express force \mathbf{F} as a Cartesian vector; then determine its coordinate direction angles.

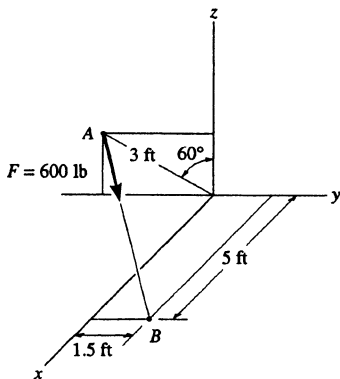

$$\mathbf{r} = (5\mathbf{i} + (1.5 + 3 \sin 60^\circ)\mathbf{j} + (0 - 3 \cos 60^\circ)\mathbf{k})$$

$$\mathbf{r} = \{5\mathbf{i} + 4.098\mathbf{j} - 1.5\mathbf{k}\} \text{ ft}$$

$$\mathbf{u} = \frac{\mathbf{r}}{r} = (0.7534\mathbf{i} + 0.6175\mathbf{j} - 0.226\mathbf{k})$$

$$\mathbf{F} = 600\mathbf{u} = (452.04\mathbf{i} + 370.49\mathbf{j} - 135.61\mathbf{k})$$

$$\mathbf{F} = \{452\mathbf{i} + 370\mathbf{j} - 136\mathbf{k}\} \text{ lb} \quad \text{Ans}$$

$$\alpha = \cos^{-1}\left(\frac{452.04}{600}\right) = 41.1^\circ \quad \text{Ans}$$

$$\beta = \cos^{-1}\left(\frac{370.49}{600}\right) = 51.9^\circ \quad \text{Ans}$$

$$\gamma = \cos^{-1}\left(\frac{-135.61}{600}\right) = 103^\circ \quad \text{Ans}$$

2-94. Determine the magnitude and coordinate direction angles of the resultant force acting at point A.

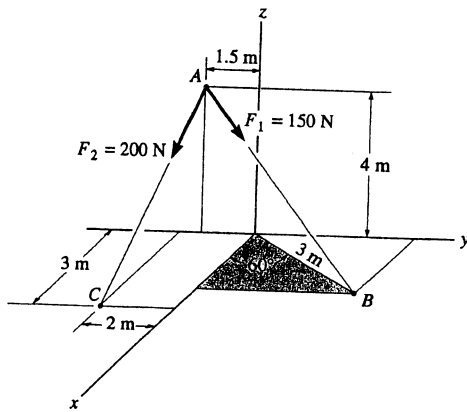

$$\mathbf{r}_{AC} = \{3\mathbf{i} - 0.5\mathbf{j} - 4\mathbf{k}\} \text{ m}$$

$$|\mathbf{r}_{AC}| = \sqrt{3^2 + (-0.5)^2 + (-4)^2} = \sqrt{25.25} = 5.02494$$

$$\mathbf{F}_2 = 200\left(\frac{3\mathbf{i} - 0.5\mathbf{j} - 4\mathbf{k}}{5.02494}\right) = (119.4044\mathbf{i} - 19.9007\mathbf{j} - 159.2059\mathbf{k})$$

$$\mathbf{r}_{AB} = (3\cos 60^\circ\mathbf{i} + (1.5 + 3\sin 60^\circ)\mathbf{j} - 4\mathbf{k})$$

$$\mathbf{r}_{AB} = (1.5\mathbf{i} + 4.0981\mathbf{j} - 4\mathbf{k})$$

$$|\mathbf{r}_{AB}| = \sqrt{(1.5)^2 + (4.0981)^2 + (-4)^2} = 5.9198$$

$$\mathbf{F}_1 = 150\left(\frac{1.5\mathbf{i} + 4.0981\mathbf{j} - 4\mathbf{k}}{5.9198}\right) = (38.0080\mathbf{i} + 103.8405\mathbf{j} - 101.3548\mathbf{k})$$

$$\mathbf{F}_R = \mathbf{F}_1 + \mathbf{F}_2 = (157.4124\mathbf{i} + 83.9398\mathbf{j} - 260.5607\mathbf{k})$$

$$F_R = \sqrt{(157.4124)^2 + (83.9398)^2 + (-260.5607)^2} = 315.7791 = 316 \text{ N} \quad \text{Ans}$$

$$\alpha = \cos^{-1}\left(\frac{157.4124}{315.7791}\right) = 60.099^\circ = 60.1^\circ \quad \text{Ans}$$

$$\beta = \cos^{-1}\left(\frac{83.9398}{315.7791}\right) = 74.584^\circ = 74.6^\circ \quad \text{Ans}$$

$$\gamma = \cos^{-1}\left(\frac{-260.5607}{315.7791}\right) = 145.60^\circ = 146^\circ \quad \text{Ans}$$

2-95. The door is held open by means of two chains. If the tension in AB and CD is $F_A = 300$ N and $F_C = 250$ N, respectively, express each of these forces in Cartesian vector form.

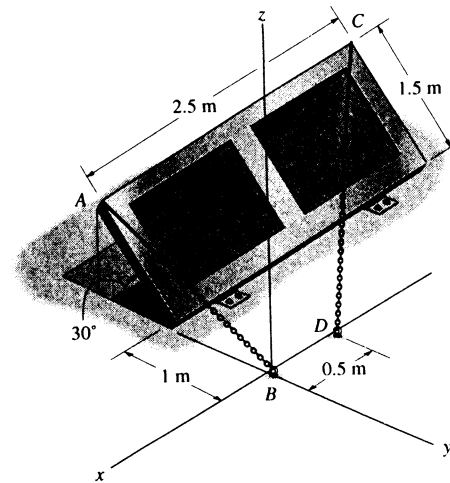

Unit Vector : First determine the position vector r_{AB} and r_{CD} . The coordinates of points A and C are

$$A[0, -(1 + 1.5\cos 30^\circ), 1.5\sin 30^\circ] \text{ m} = A(0, -2.299, 0.750) \text{ m}$$

$$C[-2.50, -(1 + 1.5\cos 30^\circ), 1.5\sin 30^\circ] \text{ m} = C(-2.50, -2.299, 0.750) \text{ m}$$

Then

$$r_{AB} = \{(0-0)\mathbf{i} + [0 - (-2.299)]\mathbf{j} + (0 - 0.750)\mathbf{k}\} \text{ m}$$

$$= \{2.299\mathbf{j} - 0.750\mathbf{k}\} \text{ m}$$

$$r_{AB} = \sqrt{2.299^2 + (-0.750)^2} = 2.418 \text{ m}$$

$$u_{AB} = \frac{r_{AB}}{r_{AB}} = \frac{2.299\mathbf{j} - 0.750\mathbf{k}}{2.418} = 0.9507\mathbf{j} - 0.3101\mathbf{k}$$

$$r_{CD} = \{[-0.5 - (-2.5)]\mathbf{i} + [0 - (-2.299)]\mathbf{j} + (0 - 0.750)\mathbf{k}\} \text{ m}$$

$$= \{2.00\mathbf{i} + 2.299\mathbf{j} - 0.750\mathbf{k}\} \text{ m}$$

$$r_{CD} = \sqrt{2.00^2 + 2.299^2 + (-0.750)^2} = 3.138 \text{ m}$$

$$u_{CD} = \frac{r_{CD}}{r_{CD}} = \frac{2.00\mathbf{i} + 2.299\mathbf{j} - 0.750\mathbf{k}}{3.138} = 0.6373\mathbf{i} + 0.7326\mathbf{j} - 0.2390\mathbf{k}$$

Force Vector :

$$F_A = F_A u_{AB} = 300\{0.9507\mathbf{j} - 0.3101\mathbf{k}\} \text{ N}$$

$$= \{285.21\mathbf{j} - 93.04\mathbf{k}\} \text{ N}$$

$$= \{285\mathbf{j} - 93.0\mathbf{k}\} \text{ N} \quad \text{Ans}$$

$$F_C = F_C u_{CD} = 250\{0.6373\mathbf{i} + 0.7326\mathbf{j} - 0.2390\mathbf{k}\} \text{ N}$$

$$= \{159.33\mathbf{i} + 183.15\mathbf{j} - 59.75\mathbf{k}\} \text{ N}$$

$$= \{159\mathbf{i} + 183\mathbf{j} - 59.7\mathbf{k}\} \text{ N} \quad \text{Ans}$$

*2-96. The two mooring cables exert forces on the stern of a ship as shown. Represent each force as a Cartesian vector and determine the magnitude and direction of the resultant.

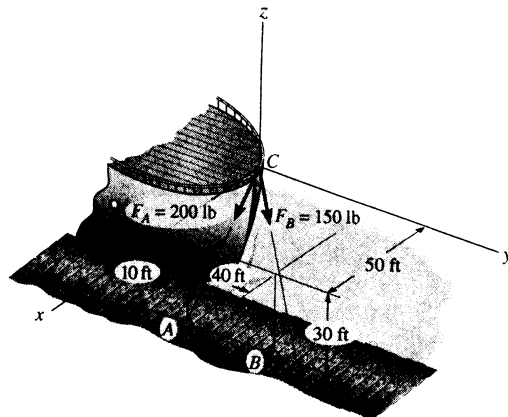

Unit Vector :

$$r_{CA} = \{(50-0)i + (10-0)j + (-30-0)k\} \text{ ft} = \{50i + 10j - 30k\} \text{ ft}$$

$$r_{CA} = \sqrt{50^2 + 10^2 + (-30)^2} = 59.16 \text{ ft}$$

$$u_{CA} = \frac{r_{CA}}{r_{CA}} = \frac{50i + 10j - 30k}{59.16} = 0.8452i + 0.1690j - 0.5071k$$

$$r_{CB} = \{(50-0)i + (50-0)j + (-30-0)k\} \text{ ft} = \{50i + 50j - 30k\} \text{ ft}$$

$$r_{CB} = \sqrt{50^2 + 50^2 + (-30)^2} = 76.81 \text{ ft}$$

$$u_{CB} = \frac{r_{CB}}{r_{CB}} = \frac{50i + 50j - 30k}{76.81} = 0.6509i + 0.6509j - 0.3906k$$

Force Vector :

$$\begin{aligned} F_A &= F_A u_{CA} = 200\{0.8452i + 0.1690j - 0.5071k\} \text{ lb} \\ &= \{169.03i + 33.81j - 101.42k\} \text{ lb} \\ &= \{169i + 33.8j - 101k\} \text{ lb} \end{aligned}$$

Ans

$$\begin{aligned} F_B &= F_B u_{CB} = 150\{0.6509i + 0.6509j - 0.3906k\} \text{ lb} \\ &= \{97.64i + 97.64j - 58.59k\} \text{ lb} \\ &= \{97.6i + 97.6j - 58.6k\} \text{ lb} \end{aligned}$$

Ans

Resultant Force :

$$\begin{aligned} F_R &= F_A + F_B \\ &= \{(169.03 + 97.64)i + (33.81 + 97.64)j + (-101.42 - 58.59)k\} \text{ lb} \\ &= \{266.67i + 131.45j - 160.00k\} \text{ lb} \end{aligned}$$

The magnitude of F_R is

$$F_R = \sqrt{266.67^2 + 131.45^2 + (-160.00)^2} = 337.63 \text{ lb} = 338 \text{ lb}$$

Ans

The coordinate direction angles of F_R are

$$\cos \alpha = \frac{266.67}{337.63} \quad \alpha = 37.8^\circ$$

Ans

$$\cos \beta = \frac{131.45}{337.63} \quad \beta = 67.1^\circ$$

Ans

$$\cos \gamma = \frac{-160.00}{337.63} \quad \gamma = 118^\circ$$

Ans

2-97. Two tractors pull on the tree with the forces shown. Represent each force as a Cartesian vector and then determine the magnitude and coordinate direction angles of the resultant force.

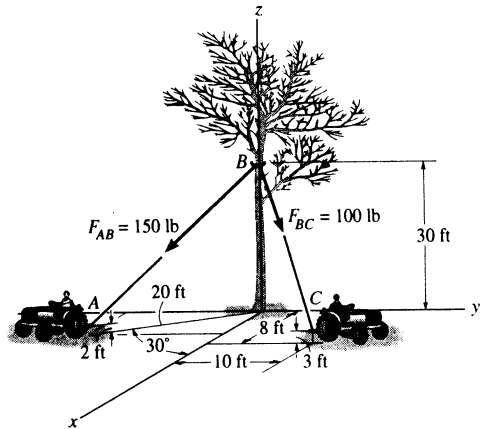

$$\begin{aligned} \mathbf{r}_{BA} &= \{(20\cos 30^\circ - 0)\mathbf{i} + (-20\sin 30^\circ - 0)\mathbf{j} + (2 - 30)\mathbf{k}\} \text{ ft} \\ &= \{17.32\mathbf{i} - 10.0\mathbf{j} - 28.0\mathbf{k}\} \text{ ft} \\ r_{BA} &= \sqrt{17.32^2 + (-10.0)^2 + (-28.0)^2} = 34.41 \text{ ft} \\ \mathbf{u}_{BA} &= \frac{\mathbf{r}_{BA}}{r_{BA}} = \frac{17.32\mathbf{i} - 10.0\mathbf{j} - 28.0\mathbf{k}}{34.41} = 0.5034\mathbf{i} - 0.2906\mathbf{j} - 0.8137\mathbf{k} \end{aligned}$$

$$\begin{aligned} \mathbf{r}_{BC} &= \{(8 - 0)\mathbf{i} + (10 - 0)\mathbf{j} + (3 - 30)\mathbf{k}\} \text{ ft} = \{8\mathbf{i} + 10\mathbf{j} - 27\mathbf{k}\} \text{ ft} \\ r_{BC} &= \sqrt{8^2 + 10^2 + (-27)^2} = 29.88 \text{ ft} \\ \mathbf{u}_{BC} &= \frac{\mathbf{r}_{BC}}{r_{BC}} = \frac{8\mathbf{i} + 10\mathbf{j} - 27\mathbf{k}}{29.88} = 0.2677\mathbf{i} + 0.3346\mathbf{j} - 0.9035\mathbf{k} \end{aligned}$$

Force Vector :

$$\begin{aligned} \mathbf{F}_{AB} &= F_{AB} \mathbf{u}_{BA} = 150\{0.5034\mathbf{i} - 0.2906\mathbf{j} - 0.8137\mathbf{k}\} \text{ lb} \\ &= \{75.51\mathbf{i} - 43.59\mathbf{j} - 122.06\mathbf{k}\} \text{ lb} \\ &= \{75.5\mathbf{i} - 43.6\mathbf{j} - 122\mathbf{k}\} \text{ lb} \quad \text{Ans} \end{aligned}$$

$$\begin{aligned} \mathbf{F}_{BC} &= F_{BC} \mathbf{u}_{BC} = 100\{0.2677\mathbf{i} + 0.3346\mathbf{j} - 0.9035\mathbf{k}\} \text{ lb} \\ &= \{26.77\mathbf{i} + 33.46\mathbf{j} - 90.35\mathbf{k}\} \text{ lb} \\ &= \{26.8\mathbf{i} + 33.5\mathbf{j} - 90.4\mathbf{k}\} \text{ lb} \quad \text{Ans} \end{aligned}$$

Resultant Force :

$$\begin{aligned} \mathbf{F}_R &= \mathbf{F}_{AB} + \mathbf{F}_{BC} \\ &= \{(75.51 + 26.77)\mathbf{i} + (-43.59 + 33.46)\mathbf{j} + (-122.06 - 90.35)\mathbf{k}\} \text{ lb} \\ &= \{102.28\mathbf{i} - 10.13\mathbf{j} - 212.41\mathbf{k}\} \text{ lb} \end{aligned}$$

The magnitude of \mathbf{F}_R is

$$\begin{aligned} F_R &= \sqrt{102.28^2 + (-10.13)^2 + (-212.41)^2} \\ &= 235.97 \text{ lb} = 236 \text{ lb} \quad \text{Ans} \end{aligned}$$

The coordinate direction angles of \mathbf{F}_R are

$$\begin{aligned} \cos \alpha &= \frac{102.28}{235.97} & \alpha &= 64.3^\circ & \text{Ans} \\ \cos \beta &= \frac{-10.13}{235.97} & \beta &= 92.5^\circ & \text{Ans} \\ \cos \gamma &= \frac{-212.41}{235.97} & \gamma &= 154^\circ & \text{Ans} \end{aligned}$$

2-98. The guy wires are used to support the telephone pole. Represent the force in each wire in Cartesian vector form.

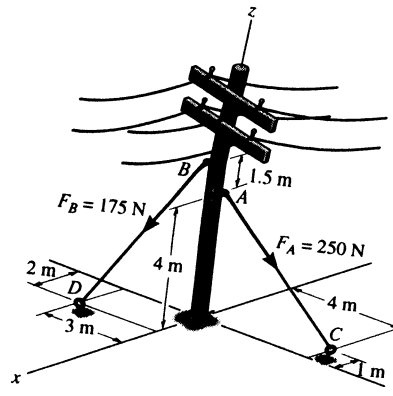

Unit Vector :

$$r_{AC} = \{(-1-0)i + (4-0)j + (0-4)k\} \text{ m} = \{-1i + 4j - 4k\} \text{ m}$$

$$r_{AC} = \sqrt{(-1)^2 + 4^2 + (-4)^2} = 5.745 \text{ m}$$

$$u_{AC} = \frac{r_{AC}}{r_{AC}} = \frac{-1i + 4j - 4k}{5.745} = -0.1741i + 0.6963j - 0.6963k$$

$$r_{BD} = \{(2-0)i + (-3-0)j + (0-5.5)k\} \text{ m} = \{2i - 3j - 5.5k\} \text{ m}$$

$$r_{BD} = \sqrt{2^2 + (-3)^2 + (-5.5)^2} = 6.576 \text{ m}$$

$$u_{BD} = \frac{r_{BD}}{r_{BD}} = \frac{2i - 3j - 5.5k}{6.576} = 0.3041i - 0.4562j - 0.8363k$$

Force Vector :

$$F_A = F_A u_{AC} = 250\{-0.1741i + 0.6963j - 0.6963k\} \text{ N}$$

$$= \{-43.52i + 174.08j - 174.08k\} \text{ N}$$

$$= \{-43.5i + 174j - 174k\} \text{ N}$$

Ans

$$F_B = F_B u_{BD} = 175\{0.3041i - 0.4562j - 0.8363k\} \text{ N}$$

$$= \{53.22i - 79.83j - 146.36k\} \text{ N}$$

$$= \{53.2i - 79.8j - 146k\} \text{ N}$$

Ans

2-99. Express each of the forces in Cartesian vector form and determine the magnitude and coordinate direction angles of the resultant force.

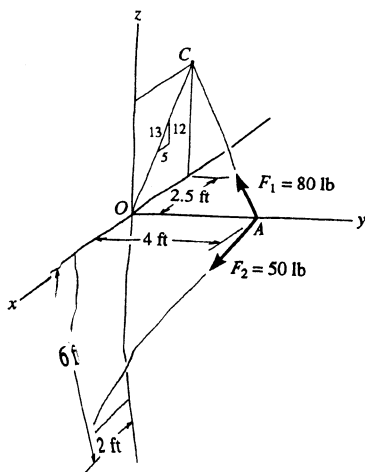

$$r_{AC} = \{-2.5i - 4j + 6k\}; \quad r_{AC} = 7.6322$$

$$F_1 = 80\left(\frac{r_{AC}}{r_{AC}}\right) = \{-26.2i - 41.9j + 62.9k\} \text{ lb}$$

Ans

$$r_{AB} = \{2i - 4j - 6k\}; \quad r_{AB} = 7.48$$

$$F_2 = 50\left(\frac{r_{AB}}{r_{AB}}\right) = \{13.4i - 26.7j - 40.1k\} \text{ lb}$$

Ans

$$F_R = F_1 + F_2$$

$$= \{-12.8i - 68.7j + 22.8k\} \text{ lb}$$

$$F_R = \sqrt{(-12.8)^2 + (-68.7)^2 + (22.8)^2} = 73.47 \text{ lb}$$

$$= 73.5 \text{ lb}$$

Ans

$$\alpha = \cos^{-1}\left(\frac{-12.8}{73.47}\right) = 100^\circ$$

Ans

$$\beta = \cos^{-1}\left(\frac{-68.7}{73.47}\right) = 159^\circ$$

Ans

$$\gamma = \cos^{-1}\left(\frac{22.8}{73.47}\right) = 71.9^\circ$$

Ans

***2-100.** The cable attached to the tractor at B exerts a force of 350 lb on the framework. Express this force as a Cartesian vector.

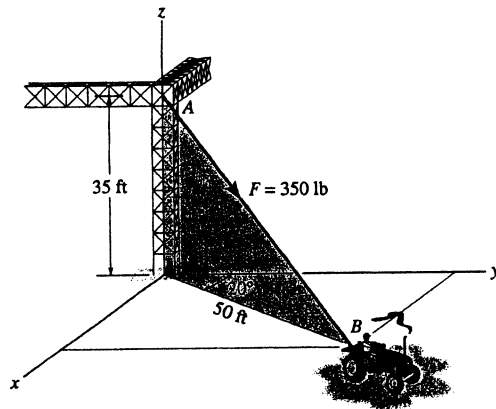

$$\mathbf{r} = 50 \sin 20^\circ \mathbf{i} + 50 \cos 20^\circ \mathbf{j} - 35 \mathbf{k}$$

$$\mathbf{r} = \{17.10\mathbf{i} + 46.98\mathbf{j} - 35\mathbf{k}\} \text{ ft}$$

$$r = \sqrt{(17.10)^2 + (46.98)^2 + (-35)^2} = 61.03 \text{ ft}$$

$$\mathbf{u} = \frac{\mathbf{r}}{r} = (0.280\mathbf{i} + 0.770\mathbf{j} - 0.573\mathbf{k})$$

$$\mathbf{F} = F\mathbf{u} = \{98.11 + 269\mathbf{j} - 201\mathbf{k}\} \text{ lb} \quad \text{Ans}$$

2-101. The load at A creates a force of 60 lb in wire AB . Express this force as a Cartesian vector acting at A and directed toward B as shown.

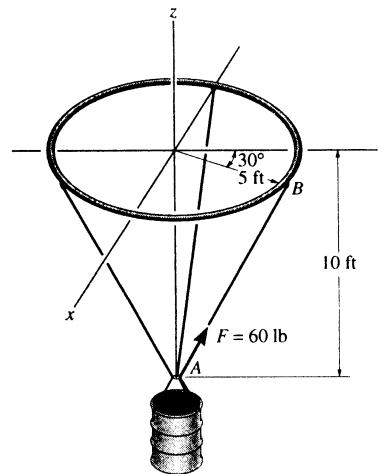

Unit Vector: First determine the position vector \mathbf{r}_{AB} . The coordinates of point B are

$$B(5 \sin 30^\circ, 5 \cos 30^\circ, 0) \text{ ft} = B(2.50, 4.330, 0) \text{ ft}$$

Then

$$\mathbf{r}_{AB} = \{(2.50 - 0)\mathbf{i} + (4.330 - 0)\mathbf{j} + [0 - (-10)]\mathbf{k}\} \text{ ft}$$

$$= \{2.50\mathbf{i} + 4.330\mathbf{j} + 10.0\mathbf{k}\} \text{ ft}$$

$$r_{AB} = \sqrt{2.50^2 + 4.330^2 + 10.0^2} = 11.180 \text{ ft}$$

$$\mathbf{u}_{AB} = \frac{\mathbf{r}_{AB}}{r_{AB}} = \frac{2.50\mathbf{i} + 4.330\mathbf{j} + 10.0\mathbf{k}}{11.180}$$

$$= 0.2236\mathbf{i} + 0.3873\mathbf{j} + 0.8944\mathbf{k}$$

Force Vector:

$$\mathbf{F} = F\mathbf{u}_{AB} = 60\{0.2236\mathbf{i} + 0.3873\mathbf{j} + 0.8944\mathbf{k}\} \text{ lb}$$

$$= \{13.4\mathbf{i} + 23.2\mathbf{j} + 53.7\mathbf{k}\} \text{ lb}$$

Ans

2-102. The pipe is supported at its ends by a cord AB . If the cord exerts a force of $F = 12$ lb on the pipe at A , express this force as a Cartesian vector.

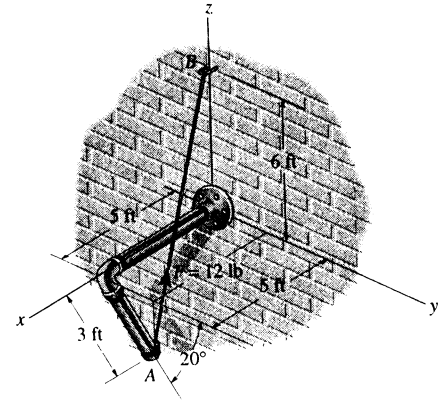

Unit Vector: The coordinates of point A are

$$A(5, 3\cos 20^\circ, -3\sin 20^\circ) \text{ ft} = A(5.00, 2.819, -1.026) \text{ ft}$$

Then

$$\begin{aligned} \mathbf{r}_{AB} &= \{(0 - 5.00)\mathbf{i} + (0 - 2.819)\mathbf{j} + [6 - (-1.026)]\mathbf{k}\} \text{ ft} \\ &= \{-5.00\mathbf{i} - 2.819\mathbf{j} + 7.026\mathbf{k}\} \text{ ft} \end{aligned}$$

$$r_{AB} = \sqrt{(-5.00)^2 + (-2.819)^2 + 7.026^2} = 9.073 \text{ ft}$$

$$\begin{aligned} \mathbf{u}_{AB} &= \frac{\mathbf{r}_{AB}}{r_{AB}} = \frac{-5.00\mathbf{i} - 2.819\mathbf{j} + 7.026\mathbf{k}}{9.073} \\ &= -0.5511\mathbf{i} - 0.3107\mathbf{j} + 0.7744\mathbf{k} \end{aligned}$$

Force Vector:

$$\begin{aligned} \mathbf{F} &= F\mathbf{u}_{AB} = 12\{-0.5511\mathbf{i} - 0.3107\mathbf{j} + 0.7744\mathbf{k}\} \text{ lb} \\ &= \{-6.61\mathbf{i} - 3.73\mathbf{j} + 9.29\mathbf{k}\} \text{ lb} \end{aligned}$$

Ans

2-103. The cord exerts a force of $\mathbf{F} = \{12\mathbf{i} + 9\mathbf{j} - 8\mathbf{k}\}$ lb on the hook. If the cord is 8 ft long, determine the location x, y of the point of attachment B , and the height z of the hook.

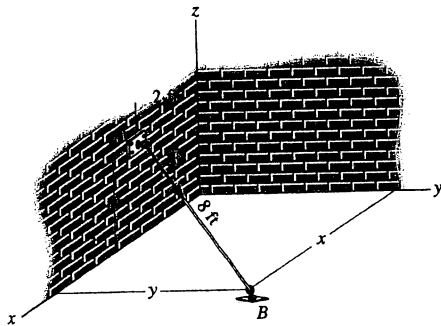

$$\mathbf{u} = \frac{\mathbf{F}}{F} = \frac{\{12\mathbf{i} + 9\mathbf{j} - 8\mathbf{k}\}}{\sqrt{(12)^2 + (9)^2 + (-8)^2}} = (0.706\mathbf{i} + 0.529\mathbf{j} - 0.471\mathbf{k})$$

$$\mathbf{r} = r\mathbf{u} = 8\mathbf{u} = \{5.65\mathbf{i} + 4.24\mathbf{j} - 3.76\mathbf{k}\} \text{ ft}$$

$$x - 2 = 5.65; \quad x = 7.65 \text{ ft} \quad \text{Ans}$$

$$y - 0 = 4.24; \quad y = 4.24 \text{ ft} \quad \text{Ans}$$

$$0 - z = -3.76; \quad z = 3.76 \text{ ft} \quad \text{Ans}$$

*2-104. The cord exerts a force of $F = 30$ lb on the hook. If the cord is 8 ft long, $z = 4$ ft, and the x component of the force is $F_x = 25$ lb, determine the location x, y of the point of attachment B of the cord to the ground.

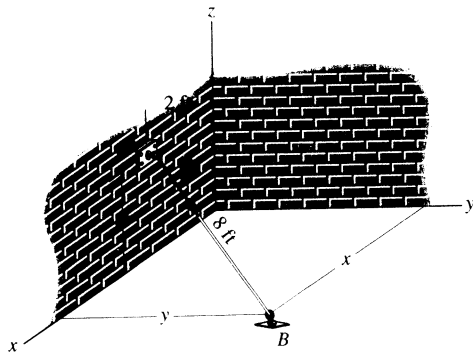

$$u_x = \frac{25}{30} = 0.833$$

$$r_x = r u_x = 8(0.833) = 6.67 \text{ ft}$$

$$x - 2 = 6.67; \quad x = 8.67 \text{ ft} \quad \text{Ans}$$

$$r = \sqrt{(6.67)^2 + y^2 + 4^2} = 8$$

$$y = 1.89 \text{ ft} \quad \text{Ans}$$

2-105. Each of the four forces acting at E has a magnitude of 28 kN. Express each force as a Cartesian vector and determine the resultant force.

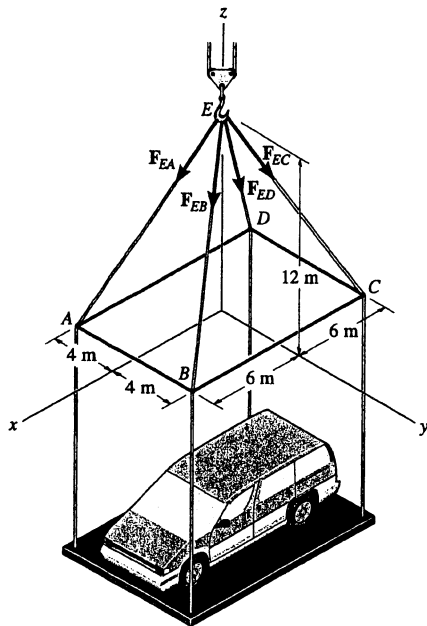

$$F_{EA} = 28\left(\frac{6}{14}i - \frac{4}{14}j - \frac{12}{14}k\right)$$

$$F_{EA} = \{12i - 8j - 24k\} \text{ kN} \quad \text{Ans}$$

$$F_{EB} = 28\left(\frac{6}{14}i + \frac{4}{14}j - \frac{12}{14}k\right)$$

$$F_{EB} = \{12i + 8j - 24k\} \text{ kN} \quad \text{Ans}$$

$$F_{EC} = 28\left(-\frac{6}{14}i + \frac{4}{14}j - \frac{12}{14}k\right)$$

$$F_{EC} = \{-12i + 8j - 24k\} \text{ kN} \quad \text{Ans}$$

$$F_{ED} = 28\left(-\frac{6}{14}i - \frac{4}{14}j - \frac{12}{14}k\right)$$

$$F_{ED} = \{-12i - 8j - 24k\} \text{ kN} \quad \text{Ans}$$

$$F_R = F_{EA} + F_{EB} + F_{EC} + F_{ED}$$

$$= \{-96k\} \text{ kN} \quad \text{Ans}$$

2-106. The tower is held in place by three cables. If the force of each cable acting on the tower is shown, determine the magnitude and coordinate direction angles α , β , γ of the resultant force. Take $x = 20$ m, $y = 15$ m.

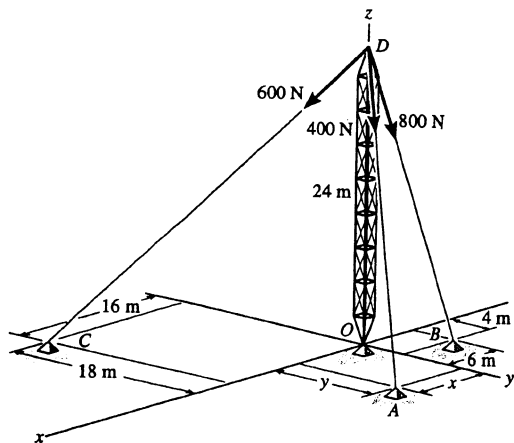

$$F_{DA} = 400\left(\frac{20}{34.66}i + \frac{15}{34.66}j - \frac{24}{34.66}k\right) \text{ N}$$

$$F_{DB} = 800\left(\frac{-6}{25.06}i + \frac{4}{25.06}j - \frac{24}{25.06}k\right) \text{ N}$$

$$F_{DC} = 600\left(\frac{16}{34}i - \frac{18}{34}j - \frac{24}{34}k\right) \text{ N}$$

$$F_R = F_{DA} + F_{DB} + F_{DC}$$

$$= \{321.66i - 16.82j - 1466.71k\} \text{ N}$$

$$F_R = \sqrt{(321.66)^2 + (-16.82)^2 + (-1466.71)^2}$$

$$= 1501.66 \text{ N} = 1.50 \text{ kN} \quad \text{Ans}$$

$$\alpha = \cos^{-1}\left(\frac{321.66}{1501.66}\right) = 77.6^\circ \quad \text{Ans}$$

$$\beta = \cos^{-1}\left(\frac{-16.82}{1501.66}\right) = 90.6^\circ \quad \text{Ans}$$

$$\gamma = \cos^{-1}\left(\frac{-1466.71}{1501.66}\right) = 168^\circ \quad \text{Ans}$$

2-107. The cable, attached to the shear-leg derrick, exerts a force on the derrick of $F = 350$ lb. Express this force as a Cartesian vector.

Unit Vector : The coordinates of point B are

$$B(50\sin 30^\circ, 50\cos 30^\circ, 0) \text{ ft} = B(25.0, 43.301, 0) \text{ ft}$$

Then

$$\begin{aligned} \mathbf{r}_{AB} &= \{(25.0-0)\mathbf{i} + (43.301-0)\mathbf{j} + (0-35)\mathbf{k}\} \text{ ft} \\ &= \{25.0\mathbf{i} + 43.301\mathbf{j} - 35.0\mathbf{k}\} \text{ ft} \end{aligned}$$

$$r_{AB} = \sqrt{25.0^2 + 43.301^2 + (-35.0)^2} = 61.033 \text{ ft}$$

$$\begin{aligned} \mathbf{u}_{AB} &= \frac{\mathbf{r}_{AB}}{r_{AB}} = \frac{25.0\mathbf{i} + 43.301\mathbf{j} - 35.0\mathbf{k}}{61.033} \\ &= 0.4096\mathbf{i} + 0.7094\mathbf{j} - 0.5735\mathbf{k} \end{aligned}$$

Force Vector :

$$\begin{aligned} \mathbf{F} = F\mathbf{u}_{AB} &= 350\{0.4096\mathbf{i} + 0.7094\mathbf{j} - 0.5735\mathbf{k}\} \text{ lb} \\ &= \{143\mathbf{i} + 248\mathbf{j} - 201\mathbf{k}\} \text{ lb} \end{aligned}$$

Ans

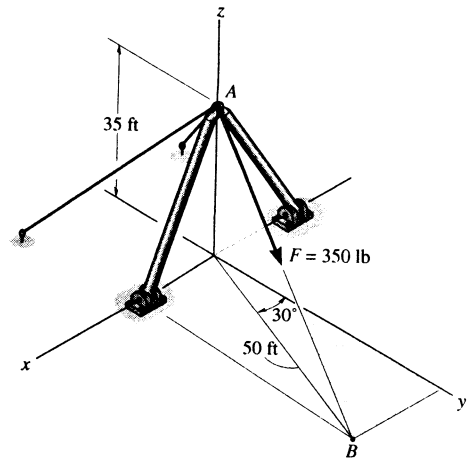

*2-108. The window is held open by chain AB . Determine the length of the chain, and express the 50-lb force acting at A along the chain as a Cartesian vector and determine its coordinate direction angles.

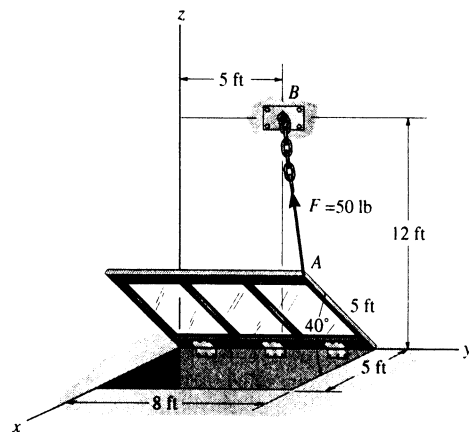

Unit Vector : The coordinates of point A are

$$A(5\cos 40^\circ, 8, 5\sin 40^\circ) \text{ ft} = A(3.830, 8.00, 3.214) \text{ ft}$$

Then

$$\begin{aligned} \mathbf{r}_{AB} &= \{(0-3.830)\mathbf{i} + (5-8.00)\mathbf{j} + (12-3.214)\mathbf{k}\} \text{ ft} \\ &= \{-3.830\mathbf{i} - 3.00\mathbf{j} + 8.786\mathbf{k}\} \text{ ft} \end{aligned}$$

$$r_{AB} = \sqrt{(-3.830)^2 + (-3.00)^2 + 8.786^2} = 10.043 \text{ ft} = 10.0 \text{ ft} \quad \text{Ans}$$

$$\begin{aligned} \mathbf{u}_{AB} &= \frac{\mathbf{r}_{AB}}{r_{AB}} = \frac{-3.830\mathbf{i} - 3.00\mathbf{j} + 8.786\mathbf{k}}{10.043} \\ &= -0.3814\mathbf{i} - 0.2987\mathbf{j} + 0.8748\mathbf{k} \end{aligned}$$

Force Vector :

$$\begin{aligned} \mathbf{F} = F\mathbf{u}_{AB} &= 50\{-0.3814\mathbf{i} - 0.2987\mathbf{j} + 0.8748\mathbf{k}\} \text{ lb} \\ &= \{-19.1\mathbf{i} - 14.9\mathbf{j} + 43.7\mathbf{k}\} \text{ lb} \end{aligned}$$

Ans

Coordinate Direction Angles : From the unit vector \mathbf{u}_{AB} obtained above, we have

| | | |
|-------------------------|-----------------------|-----|
| $\cos \alpha = -0.3814$ | $\alpha = 112^\circ$ | Ans |
| $\cos \beta = -0.2987$ | $\beta = 107^\circ$ | Ans |
| $\cos \gamma = 0.8748$ | $\gamma = 29.0^\circ$ | Ans |

2-109. Given the three vectors \mathbf{A} , \mathbf{B} , and \mathbf{D} , show that $\mathbf{A} \cdot (\mathbf{B} + \mathbf{D}) = (\mathbf{A} \cdot \mathbf{B}) + (\mathbf{A} \cdot \mathbf{D})$.

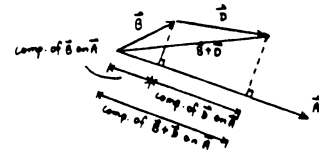

Since the component of $(\mathbf{B} + \mathbf{D})$ is equal to the sum of the components of \mathbf{B} and \mathbf{D} , then

$$\mathbf{A} \cdot (\mathbf{B} + \mathbf{D}) = \mathbf{A} \cdot \mathbf{B} + \mathbf{A} \cdot \mathbf{D} \quad (\text{QED})$$

Also,

$$\begin{aligned} \mathbf{A} \cdot (\mathbf{B} + \mathbf{D}) &= (A_x \mathbf{i} + A_y \mathbf{j} + A_z \mathbf{k}) \cdot [(B_x + D_x) \mathbf{i} + (B_y + D_y) \mathbf{j} + (B_z + D_z) \mathbf{k}] \\ &= A_x(B_x + D_x) + A_y(B_y + D_y) + A_z(B_z + D_z) \\ &= (A_x B_x + A_y B_y + A_z B_z) + (A_x D_x + A_y D_y + A_z D_z) \\ &= (\mathbf{A} \cdot \mathbf{B}) + (\mathbf{A} \cdot \mathbf{D}) \quad (\text{QED}) \end{aligned}$$

2-110. Determine the angle θ between the tails of the two vectors.

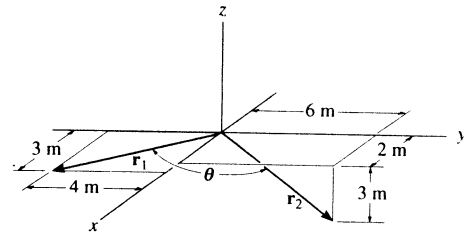

Position Vectors :

$$\begin{aligned} \mathbf{r}_1 &= \{(3-0)\mathbf{i} + (-4-0)\mathbf{j} + (0-0)\mathbf{k}\} \text{ m} \\ &= \{3\mathbf{i} - 4\mathbf{j}\} \text{ m} \end{aligned}$$

$$\begin{aligned} \mathbf{r}_2 &= \{(2-0)\mathbf{i} + (6-0)\mathbf{j} + (-3-0)\mathbf{k}\} \text{ m} \\ &= \{2\mathbf{i} + 6\mathbf{j} - 3\mathbf{k}\} \text{ m} \end{aligned}$$

The magnitude of position vectors are

$$r_1 = \sqrt{3^2 + (-4)^2} = 5.00 \text{ m} \quad r_2 = \sqrt{2^2 + 6^2 + (-3)^2} = 7.00 \text{ m}$$

Angle Between Two Vectors θ :

$$\begin{aligned} \mathbf{r}_1 \cdot \mathbf{r}_2 &= (3\mathbf{i} - 4\mathbf{j}) \cdot (2\mathbf{i} + 6\mathbf{j} - 3\mathbf{k}) \\ &= 3(2) + (-4)(6) + 0(-3) \\ &= -18.0 \text{ m}^2 \end{aligned}$$

Then,

$$\theta = \cos^{-1} \left(\frac{\mathbf{r}_1 \cdot \mathbf{r}_2}{r_1 r_2} \right) = \cos^{-1} \left[\frac{-18.0}{5.00(7.00)} \right] = 121^\circ \quad \text{Ans}$$

2-111. Determine the angle θ between the tails of the two vectors.

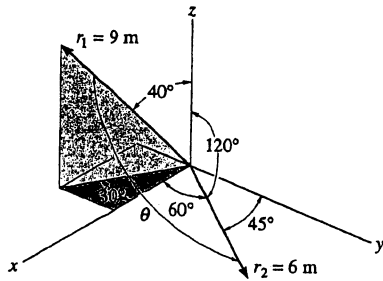

$$\mathbf{r}_1 = 9(\sin 40^\circ \cos 30^\circ \mathbf{i} - \sin 40^\circ \sin 30^\circ \mathbf{j} + \cos 40^\circ \mathbf{k})$$

$$\mathbf{r}_1 = \{5.010\mathbf{i} - 2.8925\mathbf{j} + 6.894\mathbf{k}\} \text{ m}$$

$$\mathbf{r}_2 = 6(\cos 60^\circ \mathbf{i} + \cos 45^\circ \mathbf{j} + \cos 120^\circ \mathbf{k})$$

$$\mathbf{r}_2 = \{3\mathbf{i} + 4.2426\mathbf{j} - 3\mathbf{k}\} \text{ m}$$

$$\mathbf{r}_1 \cdot \mathbf{r}_2 = 5.010(3) + (-2.8925)(4.2426) + (6.894)(-3) = -17.93$$

$$\theta = \cos^{-1} \left(\frac{\mathbf{r}_1 \cdot \mathbf{r}_2}{r_1 r_2} \right)$$

$$= \cos^{-1} \left(\frac{-17.93}{9(6)} \right) = 109^\circ$$

Ans

*2-112. Determine the magnitude of the projected component of \mathbf{r}_1 along \mathbf{r}_2 , and the projection of \mathbf{r}_2 along \mathbf{r}_1 .

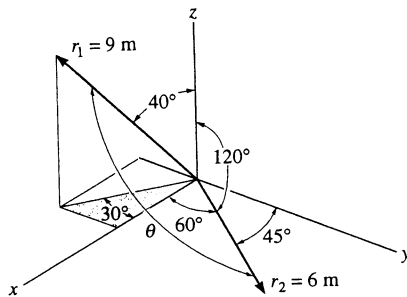

$$\mathbf{r}_1 = 9(\sin 40^\circ \cos 30^\circ \mathbf{i} - \sin 40^\circ \sin 30^\circ \mathbf{j} + \cos 40^\circ \mathbf{k})$$

$$\mathbf{r}_1 = 5.010\mathbf{i} - 2.8925\mathbf{j} + 6.894\mathbf{k}$$

$$\mathbf{r}_1 \cdot \mathbf{r}_2 = 5.010(3) + (-2.8925)(4.2426) + (6.894)(-3) = -17.93$$

$$\text{Proj. } \mathbf{r}_1 = \frac{\mathbf{r}_1 \cdot \mathbf{r}_2}{r_2} = \frac{-17.93}{6} = |2.99 \text{ m}| \quad \text{Ans}$$

$$\text{Proj. } \mathbf{r}_2 = \frac{\mathbf{r}_1 \cdot \mathbf{r}_2}{r_1} = \frac{-17.93}{9} = |1.99 \text{ m}| \quad \text{Ans}$$

2-113. Determine the angle θ between the y axis of the pole and the wire AB .

Position Vector :

$$\mathbf{r}_{AC} = \{-3\mathbf{j}\} \text{ ft}$$

$$\mathbf{r}_{AB} = \{(2-0)\mathbf{i} + (2-3)\mathbf{j} + (-2-0)\mathbf{k}\} \text{ ft}$$

$$= \{2\mathbf{i} - 1\mathbf{j} - 2\mathbf{k}\} \text{ ft}$$

The magnitudes of the position vectors are

$$r_{AC} = 3.00 \text{ ft} \quad r_{AB} = \sqrt{2^2 + (-1)^2 + (-2)^2} = 3.00 \text{ ft}$$

The Angles Between Two Vectors θ : The dot product of two vectors must be determined first.

$$\mathbf{r}_{AC} \cdot \mathbf{r}_{AB} = (-3\mathbf{j}) \cdot (2\mathbf{i} - 1\mathbf{j} - 2\mathbf{k})$$

$$= 0(2) + (-3)(-1) + 0(-2)$$

$$= 3$$

Then,

$$\theta = \cos^{-1} \left(\frac{\mathbf{r}_{AC} \cdot \mathbf{r}_{AB}}{r_{AC} r_{AB}} \right) = \cos^{-1} \left[\frac{3}{3.00(3.00)} \right] = 70.5^\circ \quad \text{Ans}$$

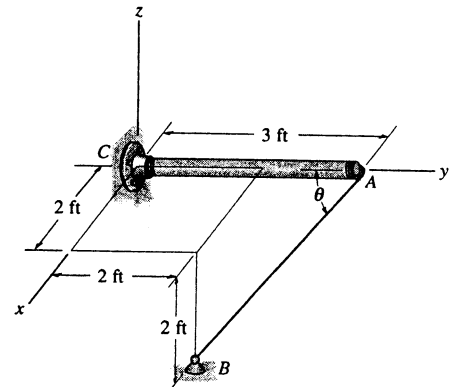

2-114. The force $F = \{25i - 50j + 10k\}$ N acts at the end A of the pipe assembly. Determine the magnitude of the components F_1 and F_2 which act along the axis of AB and perpendicular to it.

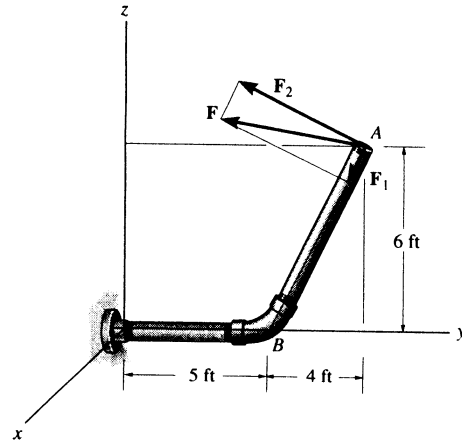

Unit Vector : The unit vector along Aa axis is

$$u_{AB} = \frac{(0-0)i + (5-9)j + (0-6)k}{\sqrt{(0-0)^2 + (5-9)^2 + (0-6)^2}} = -0.5547j - 0.8321k$$

Projected Component of F Along AB Axis :

$$\begin{aligned} F_1 &= F \cdot u_{AB} = (25i - 50j + 10k) \cdot (-0.5547j - 0.8321k) \\ &= (25)(0) + (-50)(-0.5547) + (10)(-0.8321) \\ &= 19.414 \text{ N} = 19.4 \text{ N} \end{aligned} \quad \text{Ans}$$

Component of F Perpendicular to AB Axis : The magnitude of force F is

$$F = \sqrt{25^2 + (-50)^2 + 10^2} = 56.789 \text{ N.}$$

$$F_2 = \sqrt{F^2 - F_1^2} = \sqrt{56.789^2 - 19.414^2} = 53.4 \text{ N} \quad \text{Ans}$$

2-115. Determine the angle θ between the sides of the triangular plate.

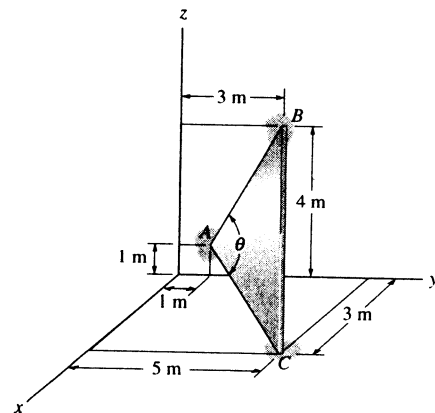

$$r_{AC} = (3i + 4j - 1k) \text{ m}$$

$$r_{AC} = \sqrt{(3)^2 + (4)^2 + (-1)^2} = 5.0990 \text{ m}$$

$$r_{AB} = (2j + 3k) \text{ m}$$

$$r_{AB} = \sqrt{(2)^2 + (3)^2} = 3.6056 \text{ m}$$

$$r_{AC} \cdot r_{AB} = 0 + 4(2) + (-1)(3) = 5$$

$$\theta = \cos^{-1} \left(\frac{r_{AC} \cdot r_{AB}}{r_{AC} r_{AB}} \right) = \cos^{-1} \frac{5}{(5.0990)(3.6056)}$$

$$\theta = 74.219^\circ = 74.2^\circ \quad \text{Ans}$$

*2-116. Determine the length of side BC of the triangular plate. Solve the problem by finding the magnitude of r_{BC} ; then check the result by first finding θ , r_{AB} , and r_{AC} and then use the cosine law.

$$r_{BC} = \{3i + 2j - 4k\} \text{ m}$$

$$r_{BC} = \sqrt{(3)^2 + (2)^2 + (-4)^2} = 5.39 \text{ m} \quad \text{Ans}$$

Also,

$$r_{AC} = \{3i + 4j - 1k\} \text{ m}$$

$$r_{AC} = \sqrt{(3)^2 + (4)^2 + (-1)^2} = 5.0990 \text{ m}$$

$$r_{AB} = \{2j + 3k\} \text{ m}$$

$$r_{AB} = \sqrt{(2)^2 + (3)^2} = 3.6056 \text{ m}$$

$$r_{AC} \cdot r_{AB} = 0 + 4(2) + (-1)(3) = 5$$

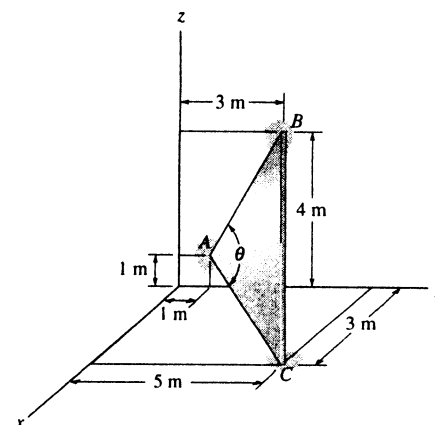

$$\theta = \cos^{-1} \left(\frac{r_{AC} \cdot r_{AB}}{r_{AC} r_{AB}} \right) = \cos^{-1} \frac{5}{(5.0990)(3.6056)}$$

$$\theta = 74.219^\circ$$

$$r_{BC} = \sqrt{(5.0990)^2 + (3.6056)^2 - 2(5.0990)(3.6056) \cos 74.219^\circ}$$

$$r_{BC} = 5.39 \text{ m} \quad \text{Ans}$$

2-117. Determine the components of F that act along rod AC and perpendicular to it. Point B is located at the midpoint of the rod.

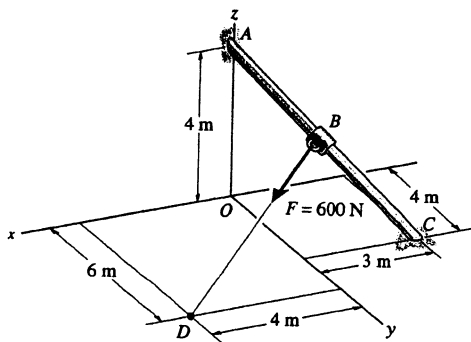

$$r_{AC} = \{-3i + 4j - 4k\}, \quad r_{AC} = \sqrt{(-3)^2 + 4^2 + (-4)^2} = \sqrt{41} \text{ m}$$

$$r_{AB} = \frac{r_{AC}}{2} = \frac{-3i + 4j - 4k}{2} = -1.5i + 2j - 2k$$

$$r_{AD} = r_{AB} + r_{BD}$$

$$r_{BD} = r_{AD} - r_{AB}$$

$$= (4i + 6j - 4k) - (-1.5i + 2j - 2k)$$

$$= \{5.5i + 4j - 2k\} \text{ m}$$

$$r_{BD} = \sqrt{(5.5)^2 + (4)^2 + (-2)^2} = 7.0887 \text{ m}$$

$$F = 600 \left(\frac{r_{BD}}{r_{BD}} \right) = 465.528i + 338.5659j - 169.2829k$$

Component of F along r_{AC} is F_{\parallel}

$$F_{\parallel} = \frac{F \cdot r_{AC}}{r_{AC}} = \frac{(465.528i + 338.5659j - 169.2829k) \cdot (-3i + 4j - 4k)}{\sqrt{41}}$$

$$F_{\parallel} = 99.1408 = 99.1 \text{ N} \quad \text{Ans}$$

Component of F perpendicular to r_{AC} is F_{\perp}

$$F_{\perp}^2 + F_{\parallel}^2 = F^2 = 600^2$$

$$F_{\perp}^2 = 600^2 - 99.1408^2$$

$$F_{\perp} = 591.75 = 592 \text{ N} \quad \text{Ans}$$

2-118. Determine the components of F that act along rod AC and perpendicular to it. Point B is located 3 m along the rod from end C .

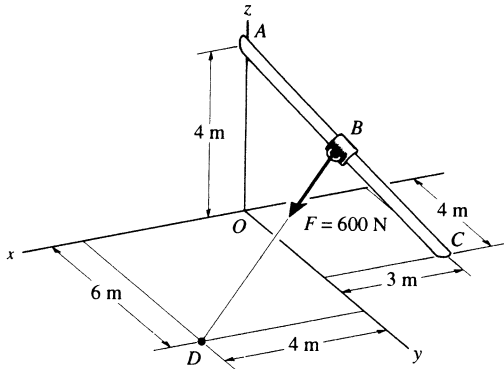

$$r_{CA} = 3i - 4j + 4k$$

$$r_{CA} = 6.403124$$

$$r_{CB} = \frac{3}{6.403124}(r_{CA}) = 1.40556i - 1.874085j + 1.874085k$$

$$r_{OB} = r_{OC} + r_{CB}$$

$$= -3i + 4j + r_{CB}$$

$$= -1.59444i + 2.1259j + 1.874085k$$

$$r_{OD} = r_{OB} + r_{BD}$$

$$r_{BD} = r_{OD} - r_{OB} = (4i + 6j) - r_{OB}$$

$$= 5.5944i + 3.8741j - 1.874085k$$

$$r_{BD} = \sqrt{(5.5944)^2 + (3.8741)^2 + (-1.874085)^2} = 7.0582$$

$$F = 600\left(\frac{r_{BD}}{r_{BD}}\right) = 475.568i + 329.326j - 159.311k$$

$$r_{AC} = (-3i + 4j - 4k), \quad r_{AC} = \sqrt{41}$$

Component of F along r_{AC} is F_1

$$F_1 = \frac{F \cdot r_{AC}}{r_{AC}} = \frac{(475.568i + 329.326j - 159.311k) \cdot (-3i + 4j - 4k)}{\sqrt{41}}$$

$$F_1 = 82.4351 = 82.4 \text{ N} \quad \text{Ans}$$

Component of F perpendicular to r_{AC} is F_2

$$F_2^2 + F_1^2 = F^2 = 600^2$$

$$F_2^2 = 600^2 - 82.4351^2$$

$$F_2 = 594 \text{ N} \quad \text{Ans}$$

2-119. The clamp is used on a jig. If the vertical force acting on the bolt is $F = \{-500k\}$ N, determine the magnitudes of the components F_1 and F_2 which act along the OA axis and perpendicular to it.

Unit Vector: The unit vector along OA axis is

$$u_{AO} = \frac{(0-20)i + (0-40)j + (0-40)k}{\sqrt{(0-20)^2 + (0-40)^2 + (0-40)^2}} = -\frac{1}{3}i - \frac{2}{3}j - \frac{2}{3}k$$

Projected Component of F Along OA Axis:

$$\begin{aligned} F_1 &= F \cdot u_{AO} = (-500k) \cdot \left(-\frac{1}{3}i - \frac{2}{3}j - \frac{2}{3}k\right) \\ &= (0)\left(-\frac{1}{3}\right) + (0)\left(-\frac{2}{3}\right) + (-500)\left(-\frac{2}{3}\right) \\ &= 333.33 \text{ N} = 333 \text{ N} \end{aligned} \quad \text{Ans}$$

Component of F Perpendicular to OA Axis: Since the magnitude of force F is $F = 500 \text{ N}$ so that

$$F_2 = \sqrt{F^2 - F_1^2} = \sqrt{500^2 - 333.33^2} = 373 \text{ N} \quad \text{Ans}$$

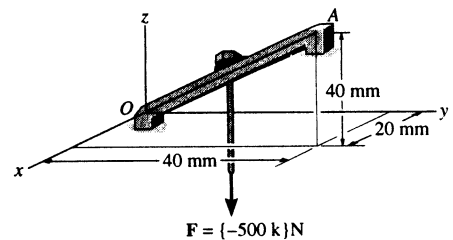

*2-120. Determine the projection of the force \mathbf{F} along the pole.

$$\text{Proj } \mathbf{F} = \mathbf{F} \cdot \mathbf{u}_p = (2\mathbf{i} + 4\mathbf{j} + 10\mathbf{k}) \cdot \left(\frac{2}{3}\mathbf{i} + \frac{2}{3}\mathbf{j} - \frac{1}{3}\mathbf{k}\right)$$

$$\text{Proj } \mathbf{F} = 0.667 \text{ kN} \quad \text{Ans}$$

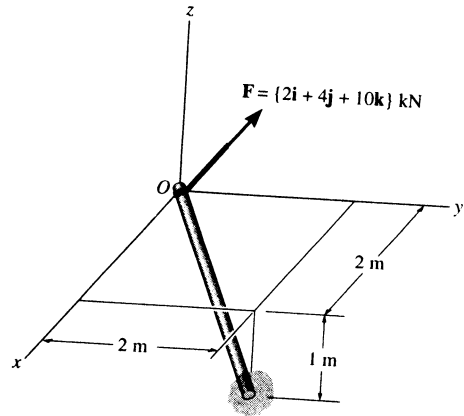

2-121. Determine the projected component of the 80-N force acting along the axis AB of the pipe.

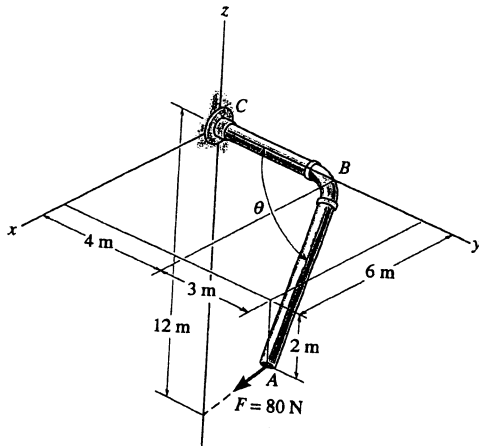

$$\mathbf{u}_{AB} = \frac{\mathbf{r}_{AB}}{r_{AB}} = \left\{ -\frac{6}{7}\mathbf{i} - \frac{3}{7}\mathbf{j} + \frac{2}{7}\mathbf{k} \right\}$$

$$= \{-0.857\mathbf{i} - 0.429\mathbf{j} + 0.286\mathbf{k}\}$$

$$\mathbf{F} = 80 \left[\frac{-6\mathbf{i} - 7\mathbf{j} - 10\mathbf{k}}{\sqrt{(6)^2 + (7)^2 + (10)^2}} \right]$$

$$= \{-35.29\mathbf{i} - 41.17\mathbf{j} - 58.82\mathbf{k}\} \text{ N}$$

$$\text{Proj. } \mathbf{F} = F \cos \theta = \mathbf{F} \cdot \mathbf{u}_{AB}$$

$$= (-35.29)(-0.857) + (-41.17)(-0.425) + (-58.82)(0.286)$$

$$= 31.1 \text{ N} \quad \text{Ans}$$

2-122. Cable OA is used to support column OB . Determine the angle θ it makes with beam OC .

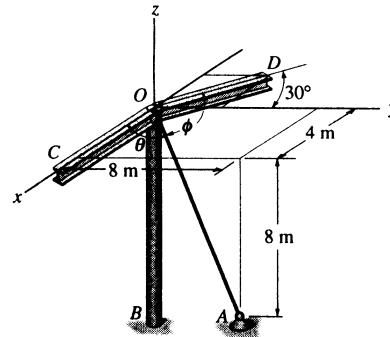

Unit Vector :

$$\mathbf{u}_{OC} = \mathbf{i}$$

$$\begin{aligned} \mathbf{u}_{OA} &= \frac{(4-0)\mathbf{i} + (8-0)\mathbf{j} + (-8-0)\mathbf{k}}{\sqrt{(4-0)^2 + (8-0)^2 + (-8-0)^2}} \\ &= \frac{1}{3}\mathbf{i} + \frac{2}{3}\mathbf{j} - \frac{2}{3}\mathbf{k} \end{aligned}$$

The Angles Between Two Vectors θ :

$$\mathbf{u}_{OC} \cdot \mathbf{u}_{OA} = (\mathbf{i}) \cdot \left(\frac{1}{3}\mathbf{i} + \frac{2}{3}\mathbf{j} - \frac{2}{3}\mathbf{k}\right) = 1\left(\frac{1}{3}\right) + (0)\left(\frac{2}{3}\right) + 0\left(-\frac{2}{3}\right) = \frac{1}{3}$$

Then,

$$\theta = \cos^{-1}(\mathbf{u}_{OC} \cdot \mathbf{u}_{OA}) = \cos^{-1}\left(\frac{1}{3}\right) = 70.5^\circ \quad \text{Ans}$$

2-123. Cable OA is used to support column OB . Determine the angle ϕ it makes with beam OD .

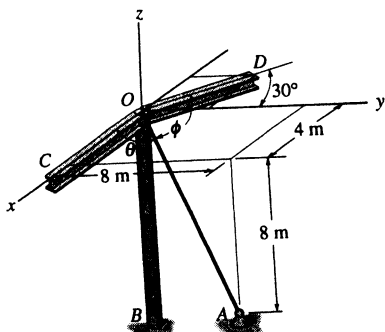

Unit Vector :

$$\mathbf{u}_{OD} = -\sin 30^\circ\mathbf{i} + \cos 30^\circ\mathbf{j} = -0.5\mathbf{i} + 0.8660\mathbf{j}$$

$$\begin{aligned} \mathbf{u}_{OA} &= \frac{(4-0)\mathbf{i} + (8-0)\mathbf{j} + (-8-0)\mathbf{k}}{\sqrt{(4-0)^2 + (8-0)^2 + (-8-0)^2}} \\ &= \frac{1}{3}\mathbf{i} + \frac{2}{3}\mathbf{j} - \frac{2}{3}\mathbf{k} \end{aligned}$$

The Angles Between Two Vectors ϕ :

$$\begin{aligned} \mathbf{u}_{OD} \cdot \mathbf{u}_{OA} &= (-0.5\mathbf{i} + 0.8660\mathbf{j}) \cdot \left(\frac{1}{3}\mathbf{i} + \frac{2}{3}\mathbf{j} - \frac{2}{3}\mathbf{k}\right) \\ &= (-0.5)\left(\frac{1}{3}\right) + (0.8660)\left(\frac{2}{3}\right) + 0\left(-\frac{2}{3}\right) \\ &= 0.4107 \end{aligned}$$

Then,

$$\phi = \cos^{-1}(\mathbf{u}_{OD} \cdot \mathbf{u}_{OA}) = \cos^{-1}(0.4107) = 65.8^\circ \quad \text{Ans}$$

*2-124. The force F acts at the end A of the pipe assembly. Determine the magnitudes of the components F_1 and F_2 which act along the axis of AB and perpendicular to it.

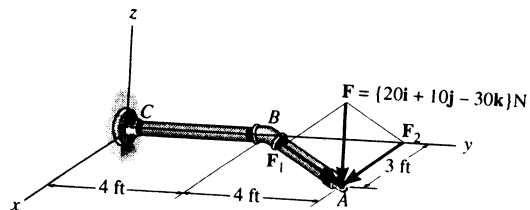

Unit Vector: The unit vector along AB axis is

$$u_{BA} = \frac{(3-0)\mathbf{i} + (8-4)\mathbf{j} + (0-0)\mathbf{k}}{\sqrt{(3-0)^2 + (8-4)^2 + (0-0)^2}} = \frac{3}{5}\mathbf{i} + \frac{4}{5}\mathbf{j}$$

Projected Component of F Along AB Axis:

$$\begin{aligned} F_1 &= F \cdot u_{BA} = (20\mathbf{i} + 10\mathbf{j} - 30\mathbf{k}) \cdot \left(\frac{3}{5}\mathbf{i} + \frac{4}{5}\mathbf{j}\right) \\ &= (20)\left(\frac{3}{5}\right) + (10)\left(\frac{4}{5}\right) + (-30)(0) \\ &= 20.0 \text{ N} \end{aligned}$$

Ans

Component of F Perpendicular to AB Axis: The magnitude of force F is $F = \sqrt{20^2 + 10^2 + (-30)^2} = 37.417 \text{ N}$.

$$F_2 = \sqrt{F^2 - F_1^2} = \sqrt{37.417^2 - 20.0^2} = 31.6 \text{ N}$$

Ans

2-125. Two cables exert forces on the pipe. Determine the magnitude of the projected component of F_1 along the line of action of F_2 .

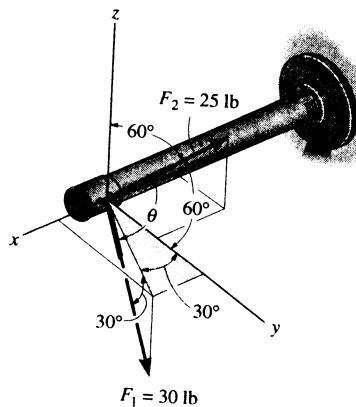

Force Vector:

$$\begin{aligned} u_{F_1} &= \cos 30^\circ \sin 30^\circ \mathbf{i} + \cos 30^\circ \cos 30^\circ \mathbf{j} - \sin 30^\circ \mathbf{k} \\ &= 0.4330\mathbf{i} + 0.75\mathbf{j} - 0.5\mathbf{k} \end{aligned}$$

$$\begin{aligned} F_1 &= F_1 u_{F_1} = 30(0.4330\mathbf{i} + 0.75\mathbf{j} - 0.5\mathbf{k}) \text{ lb} \\ &= \{12.990\mathbf{i} + 22.5\mathbf{j} - 15.0\mathbf{k}\} \text{ lb} \end{aligned}$$

Unit Vector: One can obtain the angle $\alpha = 135^\circ$ for F_2 using Eq. 2-10, $\cos^2 \alpha + \cos^2 \beta + \cos^2 \gamma = 1$, with $\beta = 60^\circ$ and $\gamma = 60^\circ$. The unit vector along the line of action of F_2 is

$$u_{F_2} = \cos 135^\circ \mathbf{i} + \cos 60^\circ \mathbf{j} + \cos 60^\circ \mathbf{k} = -0.7071\mathbf{i} + 0.5\mathbf{j} + 0.5\mathbf{k}$$

Projected Component of F_1 Along the Line of Action of F_2 :

$$\begin{aligned} (F_1)_{F_2} &= F_1 \cdot u_{F_2} = (12.990\mathbf{i} + 22.5\mathbf{j} - 15.0\mathbf{k}) \cdot (-0.7071\mathbf{i} + 0.5\mathbf{j} + 0.5\mathbf{k}) \\ &= (12.990)(-0.7071) + (22.5)(0.5) + (-15.0)(0.5) \\ &= -5.44 \text{ lb} \end{aligned}$$

Negative sign indicates that the projected component $(F_1)_{F_2}$ acts in the opposite sense of direction to that of u_{F_2} .

The magnitude is $(F_1)_{F_2} = 5.44 \text{ lb}$.

Ans

2-126. Determine the angle θ between the two cables attached to the pipe.

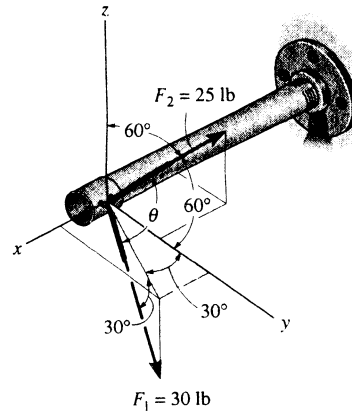

The Angles Between Two Vectors θ :

$$\begin{aligned} \mathbf{u}_{F_1} \cdot \mathbf{u}_{F_2} &= (0.4330\mathbf{i} + 0.75\mathbf{j} - 0.5\mathbf{k}) \cdot (-0.7071\mathbf{i} + 0.5\mathbf{j} + 0.5\mathbf{k}) \\ &= 0.4330(-0.7071) + 0.75(0.5) + (-0.5)(0.5) \\ &= -0.1812 \end{aligned}$$

Then,

$$\theta = \cos^{-1}(\mathbf{u}_{F_1} \cdot \mathbf{u}_{F_2}) = \cos^{-1}(-0.1812) = 100^\circ \quad \text{Ans}$$

Unit Vector:

$$\begin{aligned} \mathbf{u}_{F_1} &= \cos 30^\circ \sin 30^\circ \mathbf{i} + \cos 30^\circ \cos 30^\circ \mathbf{j} - \sin 30^\circ \mathbf{k} \\ &= 0.4330\mathbf{i} + 0.75\mathbf{j} - 0.5\mathbf{k} \end{aligned}$$

$$\begin{aligned} \mathbf{u}_{F_2} &= \cos 135^\circ \mathbf{i} + \cos 60^\circ \mathbf{j} + \cos 60^\circ \mathbf{k} \\ &= -0.7071\mathbf{i} + 0.5\mathbf{j} + 0.5\mathbf{k} \end{aligned}$$

2-127. Determine the angle θ between cables AB and AC .

Position Vector:

$$\begin{aligned} \mathbf{r}_{AB} &= \{(0-15)\mathbf{i} + (3-0)\mathbf{j} + (8-0)\mathbf{k}\} \text{ ft} \\ &= \{-15\mathbf{i} + 3\mathbf{j} + 8\mathbf{k}\} \text{ ft} \end{aligned}$$

$$\begin{aligned} \mathbf{r}_{AC} &= \{(0-15)\mathbf{i} + (-8-0)\mathbf{j} + (12-0)\mathbf{k}\} \text{ ft} \\ &= \{-15\mathbf{i} - 8\mathbf{j} + 12\mathbf{k}\} \text{ ft} \end{aligned}$$

The magnitudes of the position vectors are

$$r_{AB} = \sqrt{(-15)^2 + 3^2 + 8^2} = 17.263 \text{ ft}$$

$$r_{AC} = \sqrt{(-15)^2 + (-8)^2 + 12^2} = 20.809 \text{ ft}$$

The Angles Between Two Vectors θ :

$$\begin{aligned} \mathbf{r}_{AB} \cdot \mathbf{r}_{AC} &= (-15\mathbf{i} + 3\mathbf{j} + 8\mathbf{k}) \cdot (-15\mathbf{i} - 8\mathbf{j} + 12\mathbf{k}) \\ &= (-15)(-15) + (3)(-8) + 8(12) \\ &= 297 \text{ ft}^2 \end{aligned}$$

Then,

$$\theta = \cos^{-1} \left(\frac{\mathbf{r}_{AB} \cdot \mathbf{r}_{AC}}{r_{AB} r_{AC}} \right) = \cos^{-1} \left[\frac{297}{17.263(20.809)} \right] = 34.2^\circ \quad \text{Ans}$$

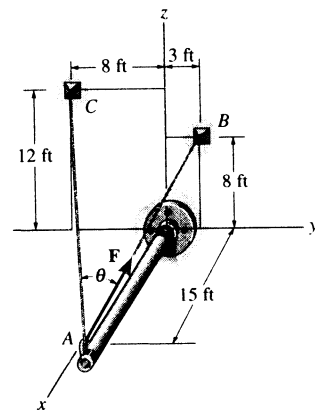

2-128. If F has a magnitude of 55 lb, determine the magnitude of its projected component acting along the x axis and along cable AC .

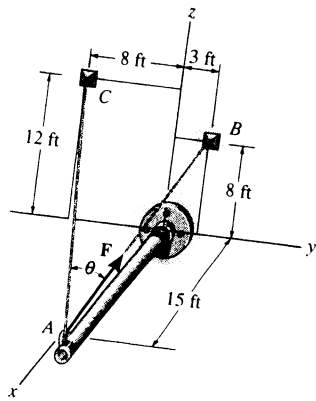

Force Vector :

$$\mathbf{u}_{AB} = \frac{(0-15)\mathbf{i} + (3-0)\mathbf{j} + (8-0)\mathbf{k}}{\sqrt{(0-15)^2 + (3-0)^2 + (8-0)^2}} = -0.8689\mathbf{i} + 0.1738\mathbf{j} + 0.4634\mathbf{k}$$

$$\mathbf{F} = F\mathbf{u}_{AB} = 55(-0.8689\mathbf{i} + 0.1738\mathbf{j} + 0.4634\mathbf{k}) \text{ lb} = \{-47.791\mathbf{i} + 9.558\mathbf{j} + 25.489\mathbf{k}\} \text{ lb}$$

Unit Vector : The unit vector along negative x axis and AC are

$$\mathbf{u}_x = -\mathbf{i}$$

$$\mathbf{u}_{AC} = \frac{(0-15)\mathbf{i} + (-8-0)\mathbf{j} + (12-0)\mathbf{k}}{\sqrt{(0-15)^2 + (-8-0)^2 + (12-0)^2}} = -0.7209\mathbf{i} - 0.3845\mathbf{j} + 0.5767\mathbf{k}$$

Projected Component of F :

$$F_x = \mathbf{F} \cdot \mathbf{u}_x = (-47.791\mathbf{i} + 9.558\mathbf{j} + 25.489\mathbf{k}) \cdot (-\mathbf{i}) = (-47.791)(-1) + 9.558(0) + 25.489(0) = 47.8 \text{ lb}$$

Ans

$$F_{AC} = \mathbf{F} \cdot \mathbf{u}_{AC} = (-47.791\mathbf{i} + 9.558\mathbf{j} + 25.489\mathbf{k}) \cdot (-0.7209\mathbf{i} - 0.3845\mathbf{j} + 0.5767\mathbf{k}) = (-47.791)(-0.7209) + (9.558)(-0.3845) + (25.489)(0.5767) = 45.5 \text{ lb}$$

Ans

The projected component acts along cable AC , F_{AC} , can also be determined using $F_{AC} = F \cos \theta$. From the solution of Prob. 2-137, $\theta = 34.2^\circ$. Then

$$F_{AC} = 55 \cos 34.2^\circ = 45.5 \text{ lb}$$

2-129. Determine the angle θ between the edges of the sheet-metal bracket.

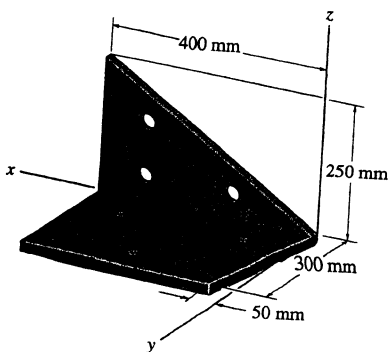

$$\mathbf{r}_1 = \{400\mathbf{i} + 250\mathbf{k}\} \text{ mm}; \quad r_1 = 471.70 \text{ mm}$$

$$\mathbf{r}_2 = \{50\mathbf{i} + 300\mathbf{j}\} \text{ mm}; \quad r_2 = 304.14 \text{ mm}$$

$$\mathbf{r}_1 \cdot \mathbf{r}_2 = (400)(50) + 0(300) + 250(0) = 20000$$

$$\theta = \cos^{-1}\left(\frac{\mathbf{r}_1 \cdot \mathbf{r}_2}{r_1 r_2}\right)$$

$$= \cos^{-1}\left(\frac{20000}{(471.70)(304.14)}\right) = 82.0^\circ \quad \text{Ans}$$

2-130. The cables each exert a force of 400 N on the post. Determine the magnitude of the projected component of F_1 along the line of action of F_2 .

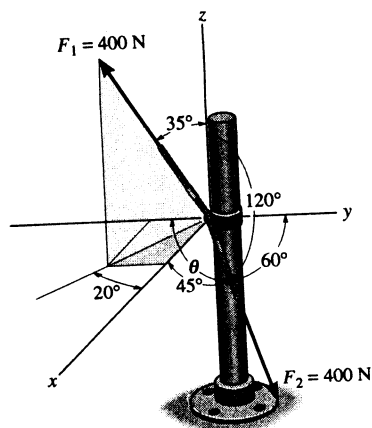

Force Vector :

$$\begin{aligned} u_{F_1} &= \sin 35^\circ \cos 20^\circ i - \sin 35^\circ \sin 20^\circ j + \cos 35^\circ k \\ &= 0.5390i - 0.1962j + 0.8192k \end{aligned}$$

$$\begin{aligned} F_1 &= F_1 u_{F_1} = 400(0.5390i - 0.1962j + 0.8192k) \text{ N} \\ &= \{215.59i - 78.47j + 327.66k\} \text{ N} \end{aligned}$$

Unit Vector : The unit vector along the line of action of F_2 is

$$\begin{aligned} u_{F_2} &= \cos 45^\circ i + \cos 60^\circ j + \cos 120^\circ k \\ &= 0.7071i + 0.5j - 0.5k \end{aligned}$$

Projected Component of F_1 Along Line of Action of F_2 :

$$\begin{aligned} (F_1)_{F_2} &= F_1 \cdot u_{F_2} = (215.59i - 78.47j + 327.66k) \cdot (0.7071i + 0.5j - 0.5k) \\ &= (215.59)(0.7071) + (-78.47)(0.5) + (327.66)(-0.5) \\ &= -50.6 \text{ N} \end{aligned}$$

Negative sign indicates that the force component $(F_1)_{F_2}$ acts in the opposite sense of direction to that of u_{F_2} .

thus the magnitude is $(F_1)_{F_2} = 50.6 \text{ N}$

Ans

2-131. Determine the angle θ between the two cables attached to the post.

Unit Vector :

$$\begin{aligned} u_{F_1} &= \sin 35^\circ \cos 20^\circ i - \sin 35^\circ \sin 20^\circ j + \cos 35^\circ k \\ &= 0.5390i - 0.1962j + 0.8192k \end{aligned}$$

$$\begin{aligned} u_{F_2} &= \cos 45^\circ i + \cos 60^\circ j + \cos 120^\circ k \\ &= 0.7071i + 0.5j - 0.5k \end{aligned}$$

The Angles Between Two Vectors θ : The dot product of two unit vectors must be determined first.

$$\begin{aligned} u_{F_1} \cdot u_{F_2} &= (0.5390i - 0.1962j + 0.8192k) \cdot (0.7071i + 0.5j - 0.5k) \\ &= 0.5390(0.7071) + (-0.1962)(0.5) + 0.8192(-0.5) \\ &= -0.1265 \end{aligned}$$

Then,

$$\theta = \cos^{-1}(u_{F_1} \cdot u_{F_2}) = \cos^{-1}(-0.1265) = 97.3^\circ \quad \text{Ans}$$

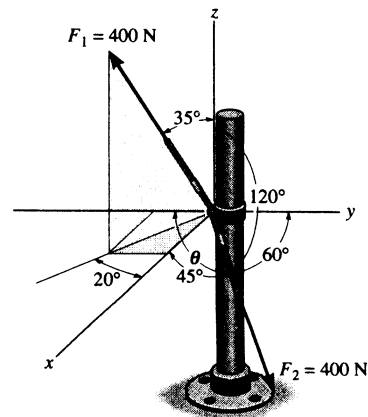

*2-132. Determine the angles θ and ϕ made between the axes OA of the flag pole and AB and AC , respectively, of each cable.

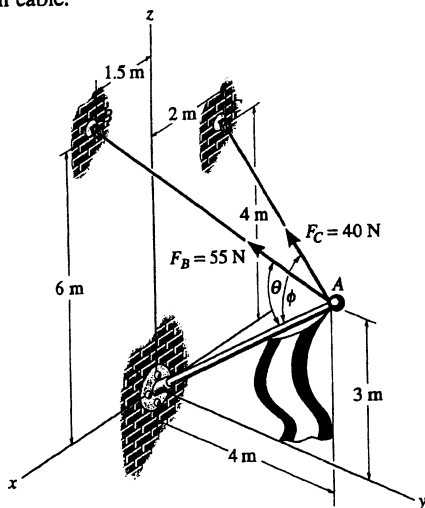

$$\mathbf{r}_{AC} = \{-2\mathbf{i} - 4\mathbf{j} + 1\mathbf{k}\} \text{ m}; \quad r_{AC} = 4.58 \text{ m}$$

$$\mathbf{r}_{AB} = \{1.5\mathbf{i} - 4\mathbf{j} + 3\mathbf{k}\} \text{ m}; \quad r_{AB} = 5.22 \text{ m}$$

$$\mathbf{r}_{AO} = \{-4\mathbf{j} - 3\mathbf{k}\} \text{ m}; \quad r_{AO} = 5.00 \text{ m}$$

$$\mathbf{r}_{AB} \cdot \mathbf{r}_{AO} = (1.5)(0) + (-4)(-4) + (3)(-3) = 7$$

$$\begin{aligned} \theta &= \cos^{-1}\left(\frac{\mathbf{r}_{AB} \cdot \mathbf{r}_{AO}}{r_{AB}r_{AO}}\right) \\ &= \cos^{-1}\left(\frac{7}{5.22(5.00)}\right) = 74.44^\circ = 74.4^\circ \end{aligned}$$

Ans

$$\mathbf{r}_{AC} \cdot \mathbf{r}_{AO} = (-2)(0) + (-4)(-4) + (1)(-3) = 13$$

$$\begin{aligned} \phi &= \cos^{-1}\left(\frac{\mathbf{r}_{AC} \cdot \mathbf{r}_{AO}}{r_{AC}r_{AO}}\right) \\ &= \cos^{-1}\left(\frac{13}{4.58(5.00)}\right) = 55.4^\circ \end{aligned}$$

Ans

2-133. Determine the magnitude and coordinate direction angles of \mathbf{F}_3 so that the resultant of the three forces acts along the positive y axis and has a magnitude of 600 lb.

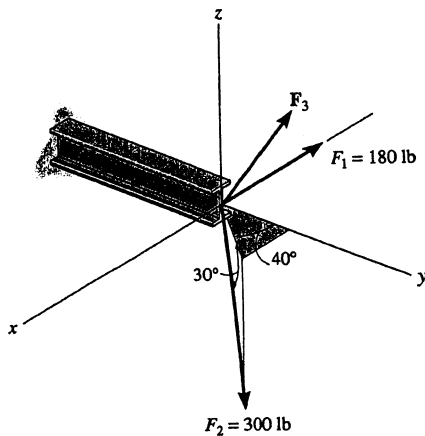

$$F_{Rx} = \Sigma F_x; \quad 0 = -180 + 300 \cos 30^\circ \sin 40^\circ + F_3 \cos \alpha$$

$$F_{Ry} = \Sigma F_y; \quad 600 = 300 \cos 30^\circ \cos 40^\circ + F_3 \cos \beta$$

$$F_{Rz} = \Sigma F_z; \quad 0 = -300 \sin 30^\circ + F_3 \cos \gamma$$

$$\cos^2 \alpha + \cos^2 \beta + \cos^2 \gamma = 1$$

Solving:

$$F_3 = 428 \text{ lb} \quad \text{Ans}$$

$$\alpha = 88.3^\circ \quad \text{Ans}$$

$$\beta = 20.6^\circ \quad \text{Ans}$$

$$\gamma = 69.5^\circ \quad \text{Ans}$$

2-134. Determine the magnitude and coordinate direction angles of F_3 so that the resultant of the three forces is zero.

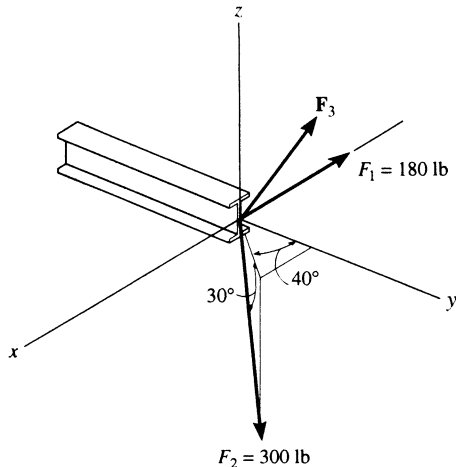

$$F_{Rx} = \Sigma F_x; \quad 0 = -180 + 300 \cos 30^\circ \sin 40^\circ + F_3 \cos \alpha$$

$$F_{Ry} = \Sigma F_y; \quad 0 = 300 \cos 30^\circ \cos 40^\circ + F_3 \cos \beta$$

$$F_{Rz} = \Sigma F_z; \quad 0 = -300 \sin 30^\circ + F_3 \cos \gamma$$

$$\cos^2 \alpha + \cos^2 \beta + \cos^2 \gamma = 1$$

Solving :

$$F_3 = 250 \text{ lb} \quad \text{Ans}$$

$$\alpha = 87.0^\circ \quad \text{Ans}$$

$$\beta = 143^\circ \quad \text{Ans}$$

$$\gamma = 53.1^\circ \quad \text{Ans}$$

2-135. Determine the design angle θ ($\theta < 90^\circ$) between the two struts so that the 500-lb horizontal force has a component of 600-lb directed from A toward C. What is the component of force acting along member BA?

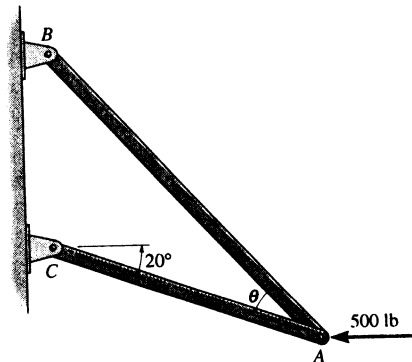

Parallelogram Law : The parallelogram law of addition is shown in Fig. (a).

Trigonometry : Using law of cosines [Fig. (b)], we have

$$F_{BA} = \sqrt{600^2 + 500^2 - 2(600)(500) \cos 20^\circ}$$

$$= 214.91 \text{ lb} = 215 \text{ lb} \quad \text{Ans}$$

The design angle θ ($\theta < 90^\circ$) can be determined using law of sines [Fig. (b)].

$$\frac{\sin \theta}{500} = \frac{\sin 20^\circ}{214.91}$$

$$\sin \theta = 0.7957$$

$$\theta = 52.7^\circ \quad \text{Ans}$$

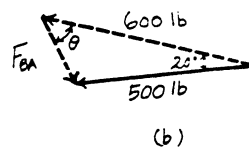
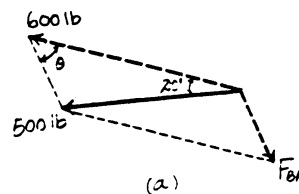

2-134. Determine the magnitude and coordinate direction angles of F_3 so that the resultant of the three forces is zero.

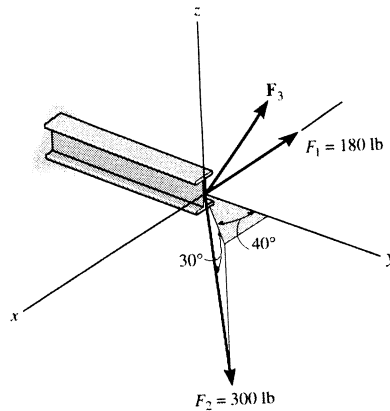

$$F_{Rx} = \Sigma F_x; \quad 0 = -180 + 300 \cos 30^\circ \sin 40^\circ + F_3 \cos \alpha$$

$$F_{Ry} = \Sigma F_y; \quad 0 = 300 \cos 30^\circ \cos 40^\circ + F_3 \cos \beta$$

$$F_{Rz} = \Sigma F_z; \quad 0 = -300 \sin 30^\circ + F_3 \cos \gamma$$

$$\cos^2 \alpha + \cos^2 \beta + \cos^2 \gamma = 1$$

Solving:

$$F_3 = 250 \text{ lb} \quad \text{Ans}$$

$$\alpha = 87.0^\circ \quad \text{Ans}$$

$$\beta = 143^\circ \quad \text{Ans}$$

$$\gamma = 53.1^\circ \quad \text{Ans}$$

2-135. Determine the design angle θ ($\theta < 90^\circ$) between the two struts so that the 500-lb horizontal force has a component of 600-lb directed from A toward C. What is the component of force acting along member BA?

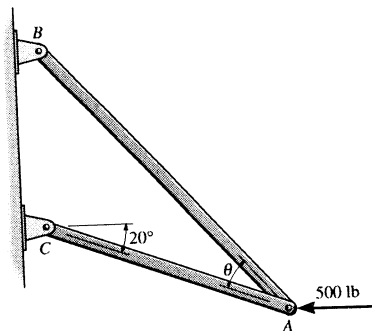

Parallelogram Law: The parallelogram law of addition is shown in Fig. (a).

Trigonometry: Using law of cosines [Fig. (b)], we have

$$F_{BA} = \sqrt{600^2 + 500^2 - 2(600)(500) \cos 20^\circ}$$

$$= 214.91 \text{ lb} = 215 \text{ lb}$$

Ans

The design angle θ ($\theta < 90^\circ$) can be determined using law of sines [Fig. (b)].

$$\frac{\sin \theta}{500} = \frac{\sin 20^\circ}{214.91}$$

$$\sin \theta = 0.7957$$

$$\theta = 52.7^\circ$$

Ans

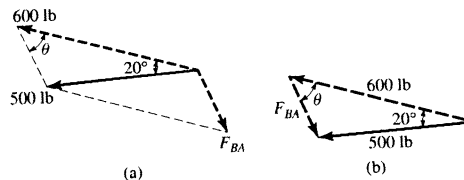

*2-136. The force F has a magnitude of 80 lb and acts at the midpoint C of the thin rod. Express the force as a Cartesian vector.

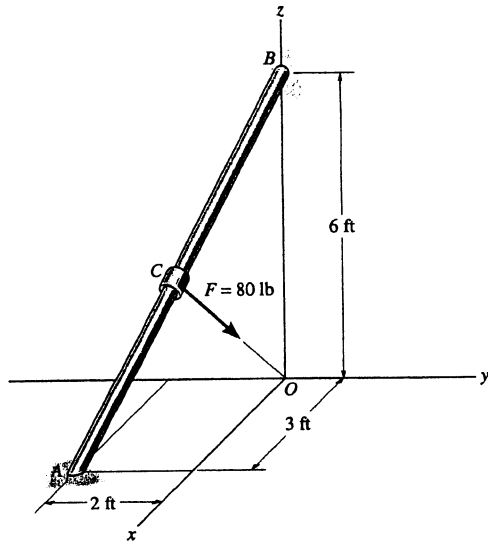

$$\mathbf{r}_{AB} = (-3\mathbf{i} + 2\mathbf{j} + 6\mathbf{k})$$

$$\mathbf{r}_{CB} = \frac{1}{2}\mathbf{r}_{AB} = (-1.5\mathbf{i} + 1\mathbf{j} + 3\mathbf{k})$$

$$\mathbf{r}_{CO} = -\mathbf{r}_{BO} + \mathbf{r}_{CB}$$

$$= -6\mathbf{k} - 1.5\mathbf{i} + 1\mathbf{j} + 3\mathbf{k}$$

$$= -1.5\mathbf{i} + 1\mathbf{j} - 3\mathbf{k}$$

$$r_{CO} = 3.5$$

$$\mathbf{F} = 80\left(\frac{\mathbf{r}_{CO}}{r_{CO}}\right) = \{-34.3\mathbf{i} + 22.9\mathbf{j} - 68.6\mathbf{k}\} \text{ lb} \quad \text{Ans}$$

*2-137. Two forces F_1 and F_2 act on the hook. If their lines of action are at an angle θ apart and the magnitude of each force is $F_1 = F_2 = F$, determine the magnitude of the resultant force F_R and the angle between F_R and F_1 .

$$\frac{F}{\sin \phi} = \frac{F}{\sin(\theta - \phi)}$$

$$\sin(\theta - \phi) = \sin \phi$$

$$\theta - \phi = \phi$$

$$\phi = \frac{\theta}{2} \quad \text{Ans}$$

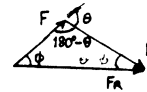

$$F_R = \sqrt{(F)^2 + (F)^2 - 2(F)(F) \cos(180^\circ - \theta)}$$

$$\text{Since } \cos(180^\circ - \theta) = -\cos \theta$$

$$F_R = F(\sqrt{2})\sqrt{1 + \cos \theta}$$

$$\text{Since } \cos\left(\frac{\theta}{2}\right) = \sqrt{\frac{1 + \cos \theta}{2}}$$

Thus

$$F_R = 2F \cos\left(\frac{\theta}{2}\right) \quad \text{Ans}$$

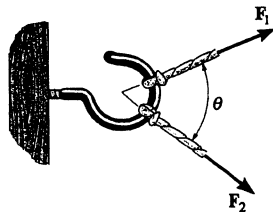

2-138. Determine the angles θ and ϕ between the wire segments.

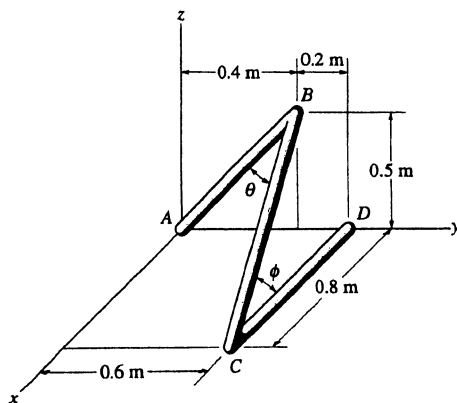

$$\mathbf{r}_{BA} = \{-0.4\mathbf{j} - 0.5\mathbf{k}\} \text{ m};$$

$$r_{BA} = 0.640 \text{ m}$$

$$\mathbf{r}_{BC} = \{0.8\mathbf{i} + 0.2\mathbf{j} - 0.5\mathbf{k}\} \text{ m};$$

$$r_{BC} = 0.964 \text{ m}$$

$$\mathbf{r}_{BA} \cdot \mathbf{r}_{BC} = 0 + (-0.4)(0.2) + (-0.5)(-0.5) = 0.170 \text{ m}^2$$

$$\theta = \cos^{-1}\left(\frac{0.170}{(0.640)(0.964)}\right) = 74.0^\circ \quad \text{Ans}$$

$$\mathbf{r}_{CB} = \{-0.8\mathbf{i} - 0.2\mathbf{j} + 0.5\mathbf{k}\} \text{ m};$$

$$r_{CB} = 0.964 \text{ m}$$

$$\mathbf{r}_{CD} = \{-0.8\mathbf{i}\} \text{ m};$$

$$r_{CD} = 0.800 \text{ m}$$

$$\mathbf{r}_{CB} \cdot \mathbf{r}_{CD} = (-0.8)(-0.8) = 0.640 \text{ m}^2$$

$$\phi = \cos^{-1}\left(\frac{0.640}{(0.964)(0.800)}\right) = 33.9^\circ \quad \text{Ans}$$

2-139. Determine the magnitudes of the projected components of the force $F = \{60i + 12j - 40k\}$ N in the direction of the cables AB and AC .

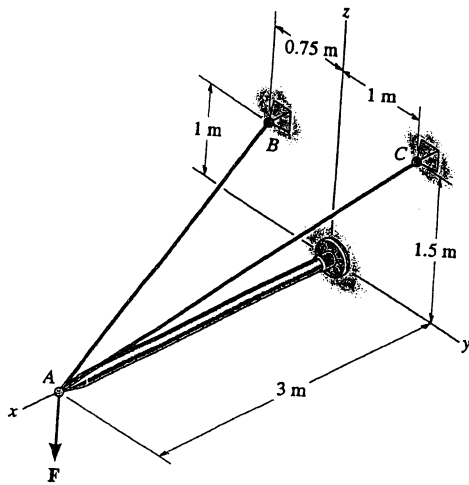

$$F = \{60i + 12j - 40k\} \text{ N}$$

$$u_{AB} = \frac{(-3i - 0.75j + k)}{\sqrt{(-3)^2 + (-0.75)^2 + 1^2}}$$

$$= (-0.9231i - 0.2308j + 0.3077k)$$

$$u_{AC} = \frac{(-3i + j + 1.5k)}{\sqrt{(-3)^2 + (1)^2 + (1.5)^2}}$$

$$= (-0.8571i + 0.2857j + 0.4286k)$$

$$\text{Proj } F_{AB} = F \cdot u_{AB}$$

$$= 60(-0.9231) + 12(-0.2308) + (-40)(0.3077) = -70.46 \text{ N}$$

$$\text{Proj } F_{AB} = 70.5 \text{ N} \quad \text{Ans}$$

$$\text{Proj } F_{AC} = F \cdot u_{AC}$$

$$= 60(-0.8571) + 12(-0.2857) + (-40)(0.4286) = -65.14 \text{ N}$$

$$\text{Proj } F_{AC} = 65.1 \text{ N} \quad \text{Ans}$$

*2-140. Determine the magnitude of the projected component of the 100-lb force acting along the axis BC of the pipe.

$$u_{CB} = \frac{(0-6)i + (12-4)j + [0-(-2)]k}{\sqrt{(0-6)^2 + (12-4)^2 + [0-(-2)]^2}}$$

$$= -0.5883i + 0.7845j + 0.1961k$$

$$F = Fu_{CB} = 100(-0.5883i + 0.7845j + 0.1961k)$$

$$= \{-58.835i + 78.446j + 19.612k\} \text{ lb}$$

Unit Vector: The unit vector along CB is

$$u_{CB} = \frac{(0-6)i + (0-4)j + [0-(-2)]k}{\sqrt{(0-6)^2 + (0-4)^2 + [0-(-2)]^2}}$$

$$= -0.8018i - 0.5345j + 0.2673k$$

Projected Component of F Along CB :

$$F_{CB} = F \cdot u_{CB} = (-58.835i + 78.446j + 19.612k) \cdot (-0.8018i - 0.5345j + 0.2673k)$$

$$= (-58.835)(-0.8018) + (78.446)(-0.5345) + (19.612)(0.2673)$$

$$= 10.5 \text{ lb}$$

Ans

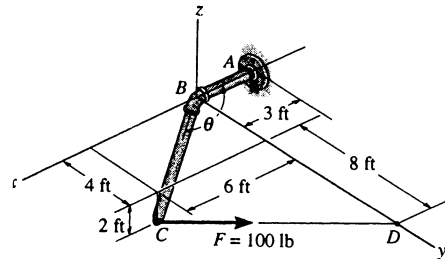

2-141. The boat is to be pulled onto the shore using two ropes. If the resultant force is to be 80 lb, directed along the keel aa , as shown, determine the magnitudes of forces T and P acting in each rope and the angle θ of P is a minimum. T acts at 30° from the keel as shown.

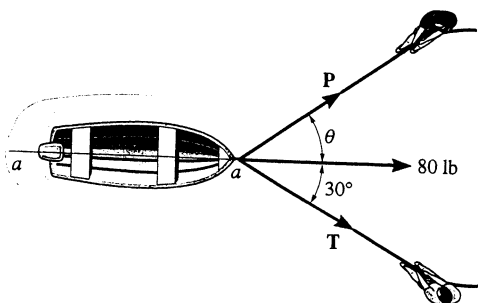

From the figure P is minimum, when

$$\theta + 30^\circ = 90^\circ \quad ; \quad \theta = 60^\circ \quad \text{Ans}$$

$$\frac{P}{\sin 30^\circ} = \frac{80}{\sin 90^\circ} \quad ; \quad P = 40 \text{ lb} \quad \text{Ans}$$

$$\frac{T}{\sin 60^\circ} = \frac{80}{\sin 90^\circ} \quad ; \quad T = 69.3 \text{ lb} \quad \text{Ans}$$

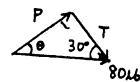

3-1. Determine the magnitudes of F_1 and F_2 so that particle P is in equilibrium.

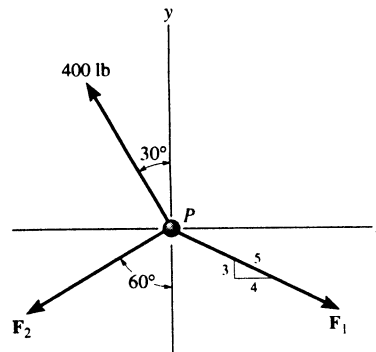

Equations of Equilibrium :

$$\begin{aligned} \rightarrow \Sigma F_x = 0; \quad F_1 \left(\frac{4}{5}\right) - 400 \sin 30^\circ - F_2 \sin 60^\circ = 0 \\ 0.8F_1 - 0.8660F_2 = 200.0 \end{aligned} \quad [1]$$

$$\begin{aligned} + \uparrow \Sigma F_y = 0; \quad 400 \cos 30^\circ - F_1 \left(\frac{3}{5}\right) - F_2 \cos 60^\circ = 0 \\ 0.6F_1 + 0.5F_2 = 346.41 \end{aligned} \quad [2]$$

Solving Eqs. [1] and [2] yields

$$F_1 = 435 \text{ lb} \quad F_2 = 171 \text{ lb} \quad \text{Ans}$$

3-2. Determine the magnitude and direction θ of F so that the particle is in equilibrium.

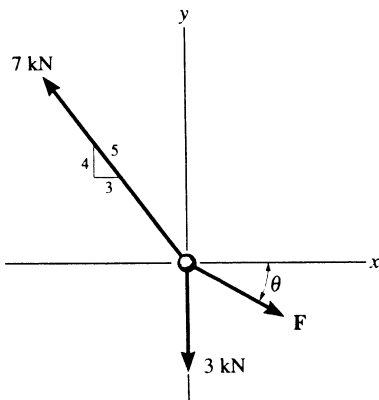

$$\rightarrow \Sigma F_x = 0; \quad -7\left(\frac{3}{5}\right) + F \cos \theta = 0$$

$$+ \uparrow \Sigma F_y = 0; \quad 7\left(\frac{4}{5}\right) - 3 - F \sin \theta = 0$$

Solving,

$$\theta = 31.8^\circ \quad \text{Ans}$$

$$F = 4.94 \text{ kN} \quad \text{Ans}$$

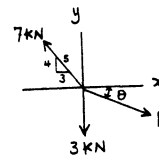

3-3. Determine the magnitude and angle θ of F_1 so that particle P is in equilibrium.

Equations of Equilibrium :

$$\begin{aligned} \rightarrow \Sigma F_x = 0; \quad 300 \left(\frac{5}{13}\right) + 450 \cos 20^\circ - F_1 \cos \theta = 0 \\ F_1 \cos \theta = 538.25 \end{aligned} \quad [1]$$

$$\begin{aligned} + \uparrow \Sigma F_y = 0; \quad 300 \left(\frac{12}{13}\right) - 450 \sin 20^\circ - F_1 \sin \theta = 0 \\ F_1 \sin \theta = 123.01 \end{aligned} \quad [2]$$

Solving Eqs. [1] and [2] yields

$$\theta = 12.9^\circ \quad F_1 = 552 \text{ N} \quad \text{Ans}$$

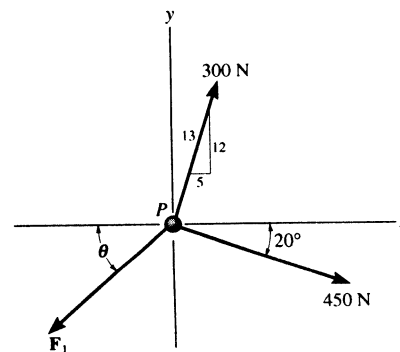

*3-4. Determine the magnitude and angle θ of F so that the particle is in equilibrium.

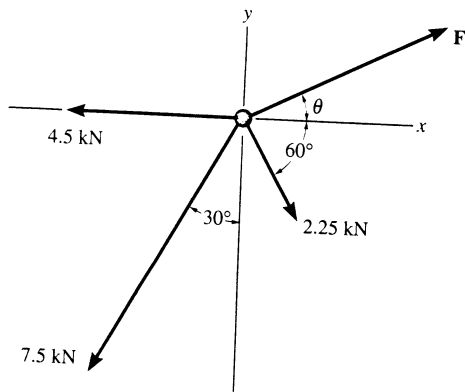

$$\rightarrow \Sigma F_x = 0;$$

$$F \cos \theta + 2.25 \cos 60^\circ - 4.5 - 7.5 \sin 30^\circ = 0$$

$$+\uparrow \Sigma F_y = 0;$$

$$F \sin \theta - 2.25 \sin 60^\circ - 7.5 \cos 30^\circ = 0$$

$$\tan \theta = \frac{8.444}{7.125} = 1.185$$

$$\theta = 49.8^\circ \quad \text{Ans}$$

$$F = 11.0 \text{ kN} \quad \text{Ans}$$

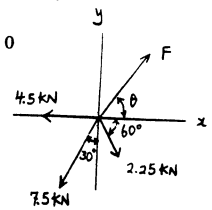

3-5. The members of a truss are pin-connected at joint O . Determine the magnitudes of F_1 and F_2 for equilibrium. Set $\theta = 60^\circ$.

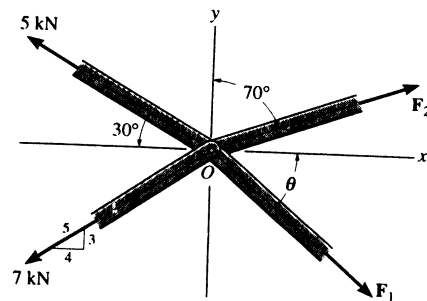

Equations of Equilibrium:

$$\rightarrow \Sigma F_x = 0; \quad F_1 \cos 60^\circ + F_2 \sin 70^\circ - 5 \cos 30^\circ - 7 \left(\frac{4}{5}\right) = 0$$

$$0.5F_1 + 0.9397F_2 = 9.9301 \quad [1]$$

$$+\uparrow \Sigma F_y = 0; \quad F_2 \cos 70^\circ - F_1 \sin 60^\circ + 5 \sin 30^\circ - 7 \left(\frac{3}{5}\right) = 0$$

$$0.3420F_2 - 0.8660F_1 = 1.70 \quad [2]$$

Solving Eqs. [1] and [2] yields

$$F_1 = 1.83 \text{ kN} \quad F_2 = 9.60 \text{ kN} \quad \text{Ans}$$

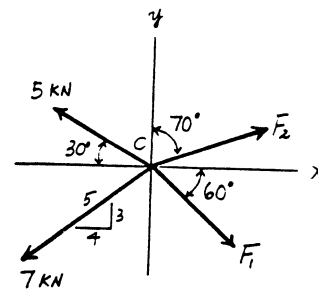

3-6. The members of a truss are pin-connected at joint O . Determine the magnitude of F_1 and its angle θ for equilibrium. Set $F_2 = 6$ kN.

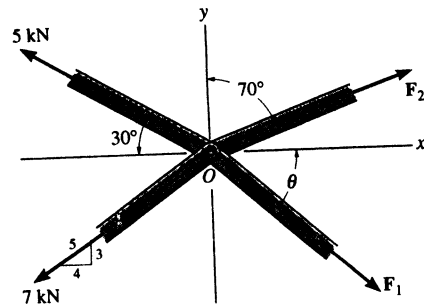

Equations of Equilibrium :

$$\begin{aligned} \rightarrow \Sigma F_x = 0; \quad F_1 \cos \theta + 6 \sin 70^\circ - 5 \cos 30^\circ - 7 \left(\frac{4}{5}\right) &= 0 \\ F_1 \cos \theta &= 4.2920 \end{aligned} \quad [1]$$

$$\begin{aligned} + \uparrow \Sigma F_y = 0; \quad 6 \cos 70^\circ - F_1 \sin \theta + 5 \sin 30^\circ - 7 \left(\frac{3}{5}\right) &= 0 \\ F_1 \sin \theta &= 0.3521 \end{aligned} \quad [2]$$

Solving Eqs. [1] and [2] yields

$$\theta = 4.69^\circ \quad F_1 = 4.31 \text{ kN} \quad \text{Ans}$$

3-7. The device shown is used to straighten the frames of wrecked autos. Determine the tension of each segment of the chain, i.e., AB and BC , if the force which the hydraulic cylinder DB exerts on point B is 3.50 kN, as shown.

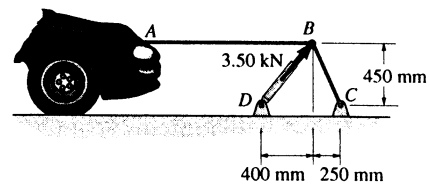

Equations of Equilibrium : A direct solution for F_{BC} can be obtained by summing forces along the y axis.

$$\begin{aligned} + \uparrow \Sigma F_y = 0; \quad 3.5 \sin 48.37^\circ - F_{BC} \sin 60.95^\circ &= 0 \\ F_{BC} &= 2.993 \text{ kN} = 2.99 \text{ kN} \quad \text{Ans} \end{aligned}$$

Using the result $F_{BC} = 2.993$ kN and summing forces along x axis, we have

$$\begin{aligned} \rightarrow \Sigma F_x = 0; \quad 3.5 \cos 48.37^\circ + 2.993 \cos 60.95^\circ - F_{AB} &= 0 \\ F_{AB} &= 3.78 \text{ kN} \quad \text{Ans} \end{aligned}$$

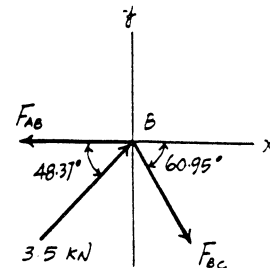

*3-8. Determine the force in cables AB and AC necessary to support the 12-kg traffic light.

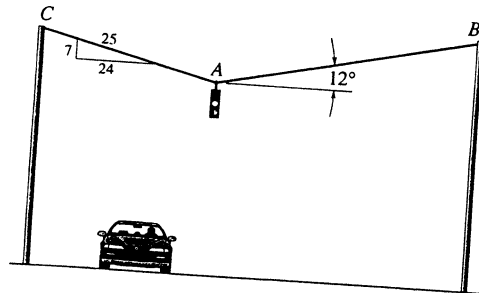

Equations of Equilibrium:

$$\begin{aligned} \rightarrow \Sigma F_x = 0; \quad F_{AB} \cos 12^\circ - F_{AC} \left(\frac{24}{25}\right) &= 0 \\ F_{AB} &= 0.9814 F_{AC} \end{aligned} \quad [1]$$

$$\begin{aligned} + \uparrow \Sigma F_y = 0; \quad F_{AB} \sin 12^\circ + F_{AC} \left(\frac{7}{25}\right) - 117.72 &= 0 \\ 0.2079 F_{AB} + 0.28 F_{AC} &= 117.72 \end{aligned} \quad [2]$$

Solving Eqs. [1] and [2] yields

$$F_{AB} = 239 \text{ N} \quad F_{AC} = 243 \text{ N} \quad \text{Ans}$$

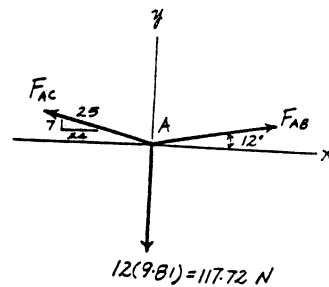

3-9. Cords AB and AC can each sustain a maximum tension of 800 lb. If the drum has a weight of 900 lb, determine the smallest angle θ at which they can be attached to the drum.

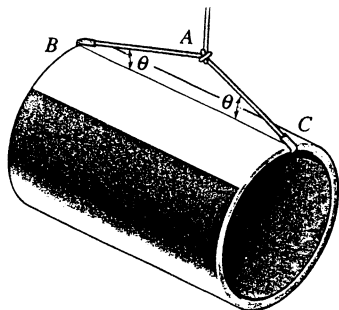

$$\begin{aligned} + \uparrow \Sigma F_y = 0; \quad 900 - 2(800) \sin \theta &= 0 \\ \theta &= 34.2^\circ \quad \text{Ans} \end{aligned}$$

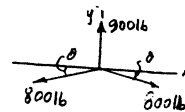

3-10. The 500-lb crate is hoisted using the ropes AB and AC . Each rope can withstand a maximum tension of 2500 lb before it breaks. If AB always remains horizontal, determine the smallest angle θ to which the crate can be hoisted.

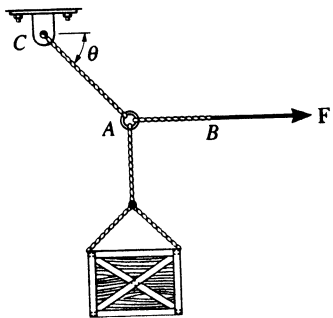

Case 1 : Assume $T_{AB} = 2500$ lb

$$\begin{aligned} \rightarrow \Sigma F_x = 0; & \quad 2500 - T_{AC} \cos \theta = 0 \\ + \uparrow \Sigma F_y = 0; & \quad T_{AC} \sin \theta - 500 = 0 \end{aligned}$$

Solving,

$$\theta = 11.31^\circ$$

$$T_{AC} = 2549.5 \text{ lb} > 2500 \text{ lb} \quad (\text{N.G.})$$

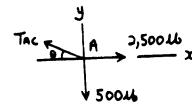

Case 2 : Assume $T_{AC} = 2500$ lb

$$+ \uparrow \Sigma F_y = 0; \quad 2500 \sin \theta - 500 = 0$$

$$\theta = 11.54^\circ$$

$$\rightarrow \Sigma F_x = 0; \quad T_{AB} - 2500 \cos 11.54^\circ = 0$$

$$T_{AB} = 2449.49 \text{ lb} < 2500 \text{ lb}$$

Thus, the smallest angle is $\theta = 11.5^\circ$ **Ans**

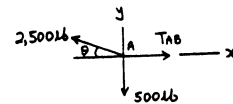

3-11. Two electrically charged pith balls, each having a mass of 0.2 g, are suspended from light threads of equal length. Determine the resultant horizontal force of repulsion, F , acting on each ball if the measured distance between them is $r = 200$ mm.

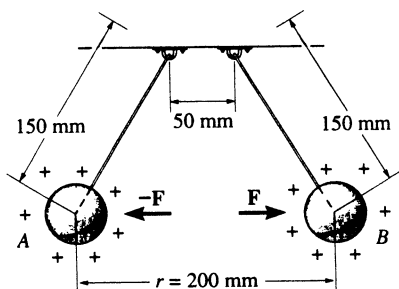

$$\rightarrow \Sigma F_x = 0; \quad F - T\left(\frac{75}{150}\right) = 0$$

$$+ \uparrow \Sigma F_y = 0; \quad T \left[\frac{\sqrt{150^2 - 75^2}}{150} \right] - 0.2(9.81)(10^{-3}) = 0$$

$$T = 2.266(10^{-3}) \text{ N}$$

$$F = 1.13 \text{ mN} \quad \text{Ans}$$

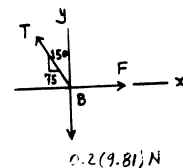

***3-12.** The concrete pipe elbow has a weight of 400 lb and the center of gravity is located at point *G*. Determine the force in the cables *AB* and *CD* needed to support it.

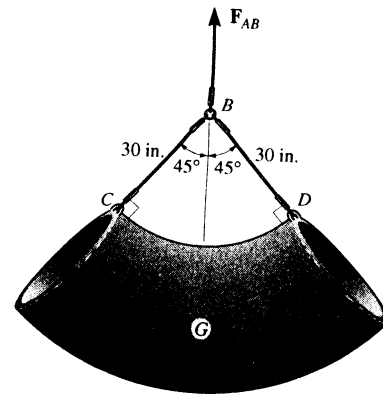

Free Body Diagram : By observation, cable *AB* has to support the entire weight of the concrete pipe. Thus,

$$F_{AB} = 400 \text{ lb} \quad \text{Ans}$$

The tension force in cable *CD* is the same throughout the cable, that is $F_{BC} = F_{BD}$.

Equations of Equilibrium :

$$\rightarrow \Sigma F_x = 0; \quad F_{BD} \sin 45^\circ - F_{BC} \sin 45^\circ = 0$$

$$F_{BC} = F_{BD} = F$$

$$+\uparrow \Sigma F_y = 0; \quad 400 - 2F \cos 45^\circ = 0$$

$$F = F_{BD} = F_{BC} = 283 \text{ lb} \quad \text{Ans}$$

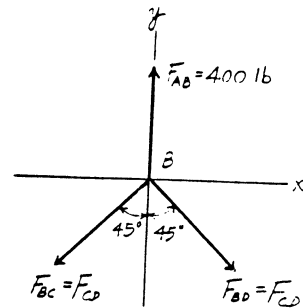

3-13. Determine the stretch in each spring for equilibrium of the 2-kg block. The springs are shown in the equilibrium position.

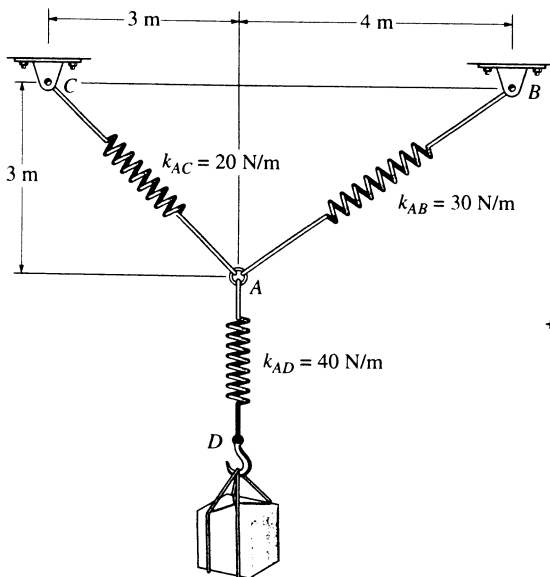

$$F_{AD} = 2(9.81) = x_{AD}(40)$$

$$x_{AD} = 0.4905 \text{ m}$$

$$\rightarrow \Sigma F_x = 0; \quad F_{AB} \left(\frac{4}{5}\right) - F_{AC} \left(\frac{1}{\sqrt{2}}\right) = 0$$

$$+\uparrow \Sigma F_y = 0; \quad F_{AC} \left(\frac{1}{\sqrt{2}}\right) + F_{AB} \left(\frac{3}{5}\right) - 2(9.81) = 0$$

$$F_{AC} = 15.86 \text{ N}$$

$$x_{AC} = \frac{15.86}{20} = 0.793 \text{ m} \quad \text{Ans}$$

$$F_{AB} = 14.01 \text{ N}$$

$$x_{AB} = \frac{14.01}{30} = 0.467 \text{ m} \quad \text{Ans}$$

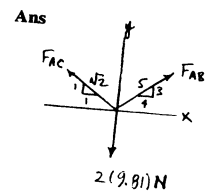

3-14. The unstretched length of spring AB is 2 m. If the block is held in the equilibrium position shown, determine the mass of the block at D .

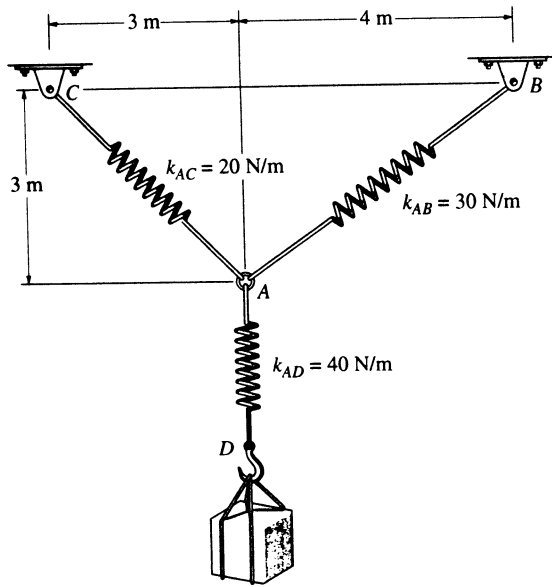

$$F = kx = 30(5-2) = 90 \text{ N}$$

$$\rightarrow \Sigma F_x = 0; \quad T \cos 45^\circ - 90\left(\frac{4}{5}\right) = 0$$

$$T = 101.82 \text{ N}$$

$$+\uparrow \Sigma F_y = 0; \quad -W + 101.82 \sin 45^\circ + 90\left(\frac{3}{5}\right) = 0$$

$$W = 126.0 \text{ N}$$

$$m = \frac{126.0}{9.81} = 12.8 \text{ kg} \quad \text{Ans}$$

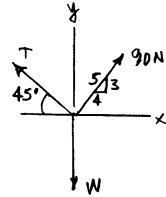

3-15. The spring ABC has a stiffness of 500 N/m and an unstretched length of 6 m. Determine the horizontal force F applied to the cord which is attached to the *small* pulley B so that the displacement of the pulley from the wall is $d = 1.5$ m.

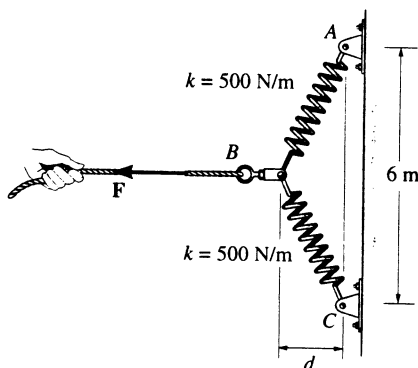

$$\rightarrow \Sigma F_x = 0; \quad \frac{1.5}{\sqrt{11.25}}(T)(2) - F = 0$$

$$T = ks = 500(\sqrt{3^2 + (1.5)^2} - 3) = 177.05 \text{ N}$$

$$F = 158 \text{ N} \quad \text{Ans}$$

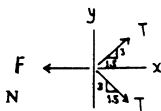

*3-16. The spring ABC has a stiffness of 500 N/m and an unstretched length of 6 m. Determine the displacement d of the cord from the wall when a force $F = 175$ N is applied to the cord.

$$\rightarrow \Sigma F_x = 0; \quad 175 = 2T \sin \theta$$

$$T \sin \theta = 87.5$$

$$T \left[\frac{d}{\sqrt{3^2 + d^2}} \right] = 87.5$$

$$T = ks = 500(\sqrt{3^2 + d^2} - 3)$$

$$d \left(1 - \frac{3}{\sqrt{9 + d^2}} \right) = 0.175$$

By trial and error :

$$d = 1.56 \text{ m} \quad \text{Ans}$$

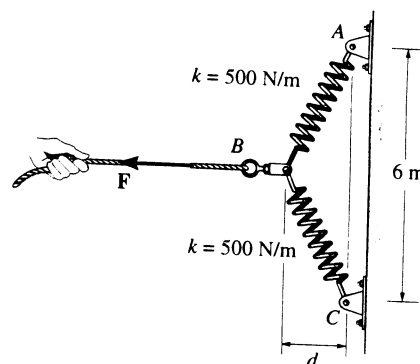
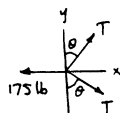

Probs. 3-15/16

3-17. Determine the maximum weight of the flowerpot that can be supported without exceeding a cable tension of 50 lb in either cable AB or AC .

Equations of Equilibrium :

$$\begin{aligned} \rightarrow \Sigma F_x = 0; \quad F_{AC} \sin 30^\circ - F_{AB} \left(\frac{3}{5}\right) &= 0 \\ F_{AC} &= 1.20 F_{AB} \end{aligned} \quad [1]$$

$$\begin{aligned} + \uparrow \Sigma F_y = 0; \quad F_{AC} \cos 30^\circ + F_{AB} \left(\frac{4}{5}\right) - W &= 0 \\ 0.8660 F_{AC} + 0.8 F_{AB} &= W \end{aligned} \quad [2]$$

Since $F_{AC} > F_{AB}$, failure will occur first at cable AC with $F_{AC} = 50$ lb. Then solving Eq. [1] and [2] yields

$$\begin{aligned} F_{AB} &= 41.67 \text{ lb} \\ W &= 76.6 \text{ lb} \end{aligned} \quad \text{Ans}$$

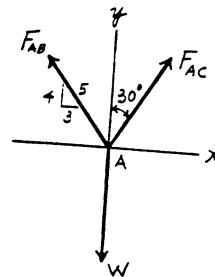
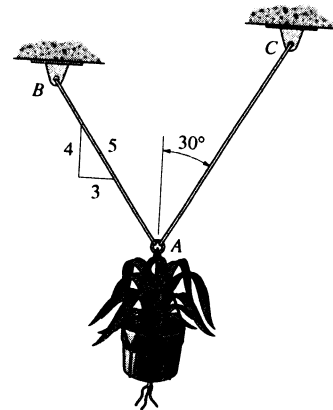

3-18. The motor at B winds up the cord attached to the 65-lb crate with a constant speed. Determine the force in cord CD supporting the pulley and the angle θ for equilibrium. Neglect the size of the pulley at C .

$$\rightarrow \Sigma F_x = 0;$$

$$F_{CD} \cos \theta - 65 \left(\frac{5}{13}\right) = 0$$

$$+ \uparrow \Sigma F_y = 0;$$

$$F_{CD} \sin \theta - 65 - 65 \left(\frac{12}{13}\right) = 0$$

$$\theta = \tan^{-1}(5) = 78.7^\circ \quad \text{Ans}$$

$$F_{CD} = 127 \text{ lb} \quad \text{Ans}$$

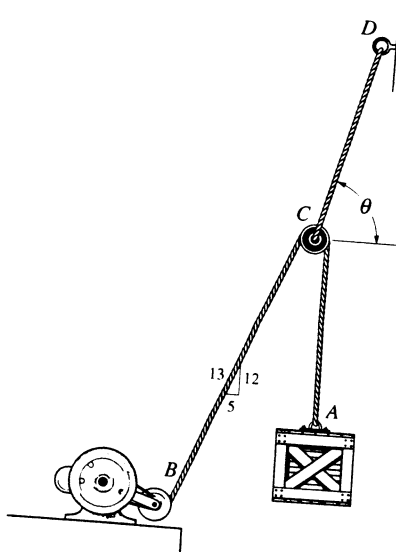
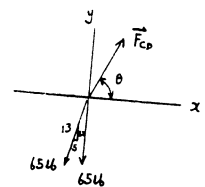

3-19. The cords BCA and CD can each support a maximum load of 100 lb. Determine the maximum weight of the crate that can be hoisted at constant velocity, and the angle θ for equilibrium.

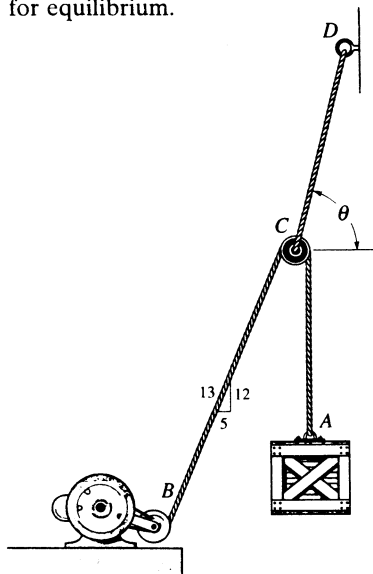

$$\begin{aligned} \rightarrow \Sigma F_x = 0; & \quad 100 \cos \theta = W \left(\frac{5}{13} \right) \\ + \uparrow \Sigma F_y = 0; & \quad 100 \sin \theta = W \left(\frac{12}{13} \right) + W \\ & \quad \theta = 78.7^\circ \quad \text{Ans} \\ & \quad W = 51.0 \text{ lb} \quad \text{Ans} \end{aligned}$$

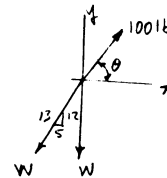

***3-20.** Determine the forces in cables AC and AB needed to hold the 20-kg ball D in equilibrium. Take $F = 300 \text{ N}$ and $d = 1 \text{ m}$.

Equations of Equilibrium :

$$\begin{aligned} \rightarrow \Sigma F_x = 0; & \quad 300 - F_{AB} \left(\frac{4}{\sqrt{41}} \right) - F_{AC} \left(\frac{2}{\sqrt{5}} \right) = 0 \\ & \quad 0.6247 F_{AB} + 0.8944 F_{AC} = 300 \end{aligned} \quad [1]$$

$$\begin{aligned} + \uparrow \Sigma F_y = 0; & \quad F_{AB} \left(\frac{5}{\sqrt{41}} \right) + F_{AC} \left(\frac{1}{\sqrt{5}} \right) - 196.2 = 0 \\ & \quad 0.7809 F_{AB} + 0.4472 F_{AC} = 196.2 \end{aligned} \quad [2]$$

Solving Eqs. [1] and [2] yields

$$F_{AB} = 98.6 \text{ N} \quad F_{AC} = 267 \text{ N} \quad \text{Ans}$$

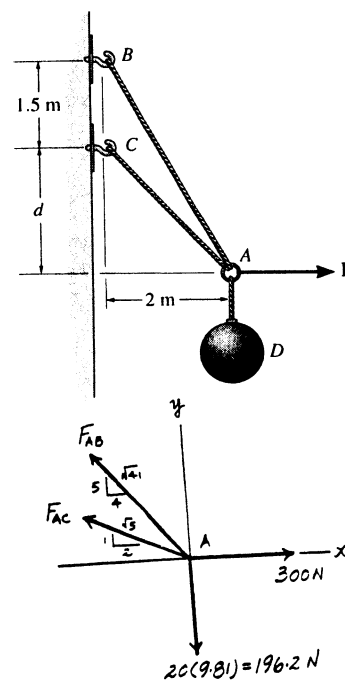

3-21. The ball D has a mass of 20 kg. If a force of $F = 100\text{ N}$ is applied horizontally to the ring at A , determine the largest dimension d so that the force in cable AC is zero.

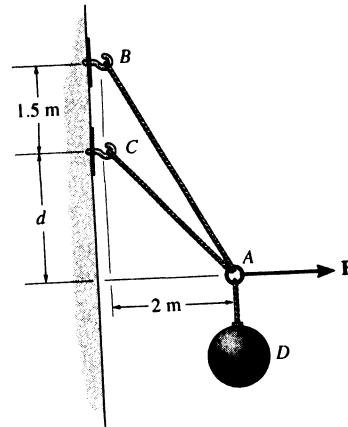

Equations of Equilibrium :

$$\rightarrow \Sigma F_x = 0; \quad 100 - F_{AB} \cos \theta = 0 \quad F_{AB} \cos \theta = 100 \quad [1]$$

$$+ \uparrow \Sigma F_y = 0; \quad F_{AB} \sin \theta - 196.2 = 0 \quad F_{AB} \sin \theta = 196.2 \quad [2]$$

Solving Eqs. [1] and [2] yields

$$\theta = 62.99^\circ \quad F_{AB} = 220.21\text{ N}$$

From the geometry,

$$d + 1.5 = 2 \tan 62.99^\circ$$

$$d = 2.42\text{ m}$$

Ans

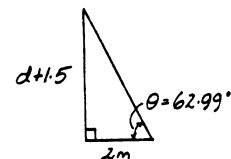
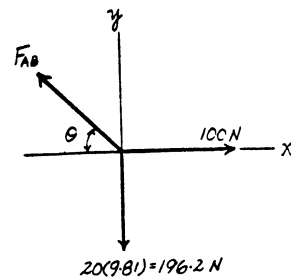

3-22. The block has a weight of 20 lb and is being hoisted at uniform velocity. Determine the angle θ for equilibrium and the required force in each cord.

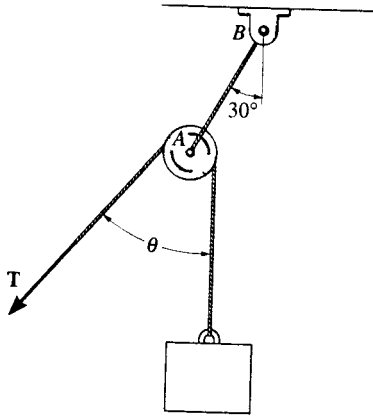

Point A :

$$\rightarrow \Sigma F_x = 0; \quad T_{AB} \cos 60^\circ - 20 \sin \theta = 0$$

$$T_{AB} \cos 60^\circ = 20 \sin \theta$$

$$+\uparrow \Sigma F_y = 0; \quad T_{AB} \sin 60^\circ - 20 - 20 \cos \theta = 0$$

$$T_{AB} \sin 60^\circ = 20(1 + \cos \theta)$$

$$\tan 60^\circ = \frac{1 + \cos \theta}{\sin \theta}$$

$$\tan 60^\circ \sin \theta = 1 + \cos \theta$$

$$\theta = 60^\circ$$

Ans

$$T_{AB} = \frac{20 \sin 60^\circ}{\cos 60^\circ} = 34.6 \text{ lb}$$

Ans

Also :

$$\Sigma F_y = 0; \quad \text{Requires } \frac{\theta}{2} = 30^\circ$$

$$\theta = 60^\circ$$

Ans

$$\swarrow \Sigma F_x = 0; \quad T_{AB} - 2[20 \cos 30^\circ] = 0$$

$$T_{AB} = 34.6 \text{ lb}$$

Ans

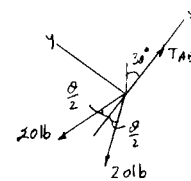
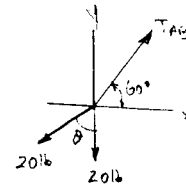

3-23. Determine the maximum weight W of the block that can be suspended in the position shown if each cord can support a maximum tension of 80 lb. Also, what is the angle θ for equilibrium?

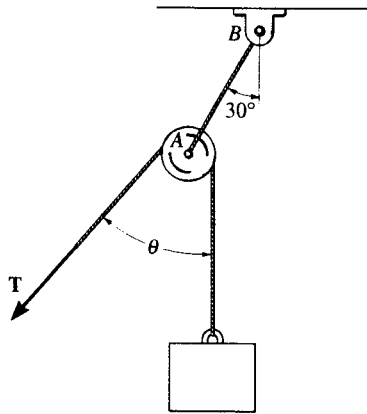

1) Assume $T_{AB} = 80$ lb

$$+\uparrow \Sigma F_y = 0; \quad 80 \sin 60^\circ - W - W \cos \theta = 0$$

$$80 \sin 60^\circ = W(1 + \cos \theta) \quad (1)$$

$$\rightarrow \Sigma F_x = 0; \quad 80 \cos 60^\circ - W \sin \theta = 0$$

$$80 \cos 60^\circ = W \sin \theta \quad (2)$$

$$\tan 60^\circ = \frac{1 + \cos \theta}{\sin \theta}$$

$$\tan 60^\circ \sin \theta = 1 + \cos \theta$$

$$\theta = 60^\circ \quad \text{Ans}$$

$$W = \frac{80 \cos 60^\circ}{\sin 60^\circ} = 46.188 \text{ lb} < 80 \text{ lb} \quad (\text{O.K.})$$

2) Assume $W = 80$ lb

$$+\uparrow \Sigma F_y = 0; \quad T \sin 60^\circ - 80 - 80 \cos \theta = 0$$

$$T \sin 60^\circ = 80(1 + \cos \theta) \quad (3)$$

$$\rightarrow \Sigma F_x = 0; \quad T \cos 60^\circ - 80 \sin \theta = 0$$

$$T \cos 60^\circ = 80 \sin \theta \quad (4)$$

$$\tan 60^\circ = \frac{1 + \cos \theta}{\sin \theta}$$

$$\tan 60^\circ \sin \theta = 1 + \cos \theta$$

$$\theta = 60^\circ$$

$$T = \frac{80 \sin 60^\circ}{\cos 60^\circ} = 138.6 \text{ lb} > 80 \text{ lb} \quad (\text{N.G.})$$

Thus, $W = 46.2$ lb **Ans**

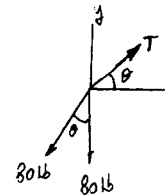
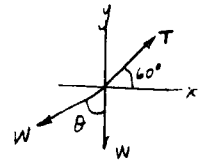

*3-24. Determine the magnitude and direction θ of the equilibrium force F_{AB} exerted along link AB by the tractive apparatus shown. The suspended mass is 10 kg. Neglect the size of the pulley at A .

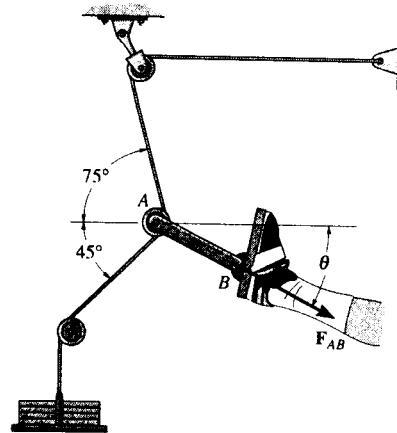

Free Body Diagram : The tension in the cord is the same throughout the cord, that is $10(9.81) = 98.1$ N.

Equations of Equilibrium :

$$\begin{aligned} \rightarrow \Sigma F_x = 0; \quad F_{AB} \cos \theta - 98.1 \cos 75^\circ - 98.1 \cos 45^\circ &= 0 \\ F_{AB} \cos \theta &= 94.757 \end{aligned} \quad [1]$$

$$\begin{aligned} + \uparrow \Sigma F_y = 0; \quad 98.1 \sin 75^\circ - 98.1 \sin 45^\circ - F_{AB} \sin \theta &= 0 \\ F_{AB} \sin \theta &= 25.390 \end{aligned} \quad [2]$$

Solving Eqs. [1] and [2] yields

$$\theta = 15.0^\circ \quad F_{AB} = 98.1 \text{ N} \quad \text{Ans}$$

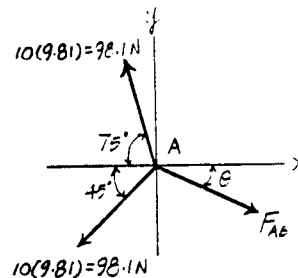

3-25. Blocks D and F weigh 5 lb each and block E weighs 8 lb. Determine the sag s for equilibrium. Neglect the size of the pulleys.

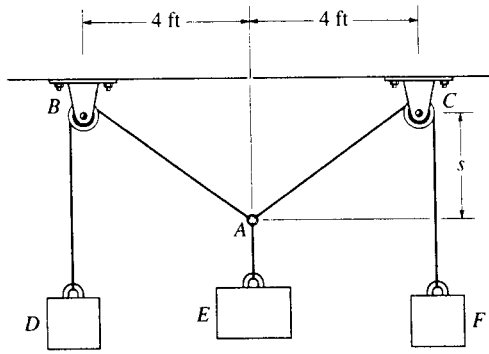

$$+\uparrow \Sigma F_y = 0;$$

$$2(5) \sin \theta - 8 = 0$$

$$\theta = \sin^{-1}(0.8) = 53.13^\circ$$

$$\tan \theta = \frac{s}{4}$$

$$s = 4 \tan 53.13^\circ = 5.33 \text{ ft}$$

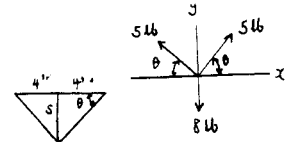

Ans

3-26. If blocks D and F weigh 5 lb each, determine the weight of block E if the sag $s = 3$ ft. Neglect the size of the pulleys.

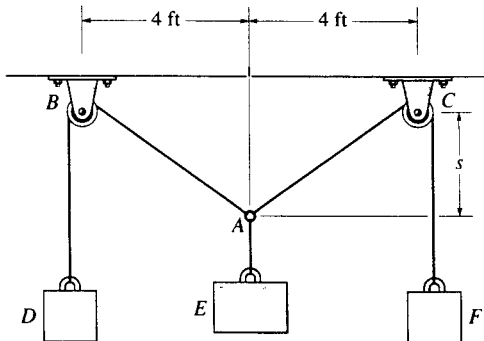

$$+\uparrow \Sigma F_y = 0;$$

$$2(5)\left(\frac{3}{5}\right) - W = 0$$

$$W = 6 \text{ lb}$$

Ans



3-27. The lift sling is used to hoist a container having a mass of 500 kg. Determine the force in each of the cables AB and AC as a function of θ . If the maximum tension allowed in each cable is 5 kN, determine the shortest lengths of cables AB and AC that can be used for the lift. The center of gravity of the container is located at G .

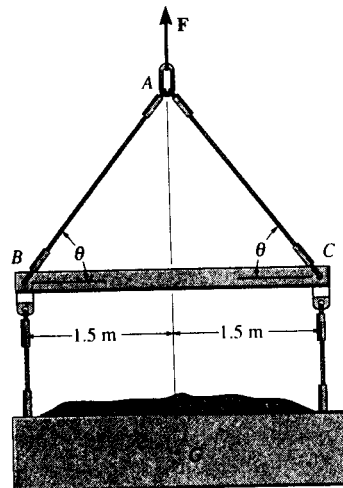

Free Body Diagram : By observation, the force F_1 has to support the entire weight of the container. Thus, $F_1 = 500(9.81) = 4905 \text{ N}$.

Equations of Equilibrium :

$$\rightarrow \Sigma F_x = 0; \quad F_{AC} \cos \theta - F_{AB} \cos \theta = 0 \quad F_{AC} = F_{AB} = F$$

$$+ \uparrow \Sigma F_y = 0; \quad 4905 - 2F \sin \theta = 0 \quad F = \{2452.5 \csc \theta\} \text{ N}$$

Thus, $F_{AC} = F_{AB} = F = \{2.45 \csc \theta\} \text{ kN}$ **Ans**

If the maximum allowable tension in the cable is 5 kN, then

$$2452.5 \csc \theta = 5000 \\ \theta = 29.37^\circ$$

From the geometry, $l = \frac{1.5}{\cos \theta}$ and $\theta = 29.37^\circ$. Therefore

$$l = \frac{1.5}{\cos 29.37^\circ} = 1.72 \text{ m} \quad \text{Ans}$$

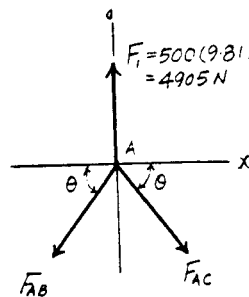

*3-28. The load has a mass of 15 kg and is lifted by the pulley system shown. Determine the force F in the cord as a function of the angle θ . Plot the function of force F versus the angle θ for $0 \leq \theta \leq 90^\circ$.

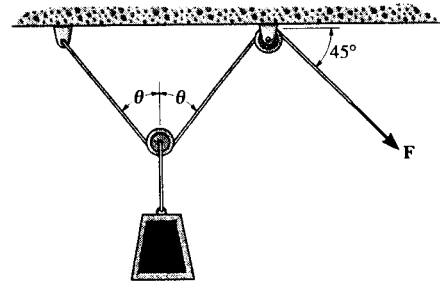

Free Body Diagram : The tension force is the same throughout the cord.

Equations of Equilibrium :

$$\rightarrow \Sigma F_x = 0; \quad F \sin \theta - F \sin \theta = 0 \quad (\text{Satisfied!})$$

$$+ \uparrow \Sigma F_y = 0; \quad 2F \cos \theta - 147.15 = 0$$

$$F = \{73.6 \sec \theta\} \text{ N}$$

Ans

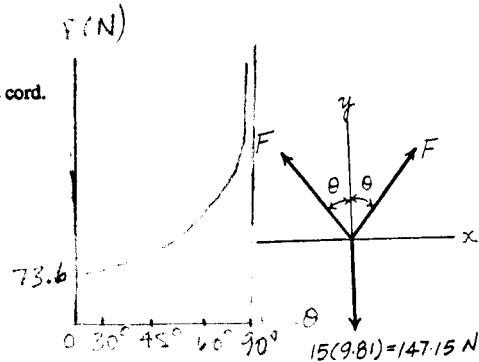

3-29. The picture has a weight of 10 lb and is to be hung over the smooth pin B . If a string is attached to the frame at points A and C , and the maximum force the string can support is 15 lb, determine the shortest string that can be safely used.

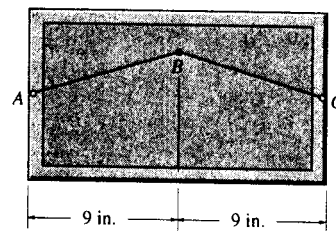

Free Body Diagram : Since the pin is smooth, the tension force in the cord is the same throughout the cord.

Equations of Equilibrium :

$$\rightarrow \Sigma F_x = 0; \quad T \cos \theta - T \cos \theta = 0 \quad (\text{Satisfied!})$$

$$+ \uparrow \Sigma F_y = 0; \quad 10 - 2T \sin \theta = 0 \quad T = \frac{5}{\sin \theta}$$

If tension in the cord cannot exceed 15 lb, then

$$\frac{5}{\sin \theta} = 15$$

$$\theta = 19.47^\circ$$

From the geometry, $\frac{l}{2} = \frac{9}{\cos \theta}$ and $\theta = 19.47^\circ$. Therefore

$$l = \frac{18}{\cos 19.47^\circ} = 19.1 \text{ in.}$$

Ans

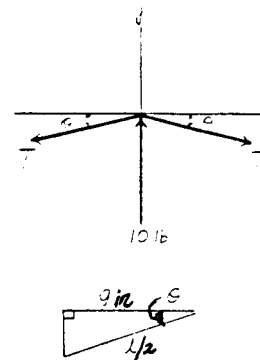

3-30. The 200-lb uniform tank is suspended by means of a 6-ft-long cable, which is attached to the sides of the tank and passes over the small pulley located at O . If the cable can be attached at either points A and B , or C and D , determine which attachment produces the least amount of tension in the cable. What is this tension?

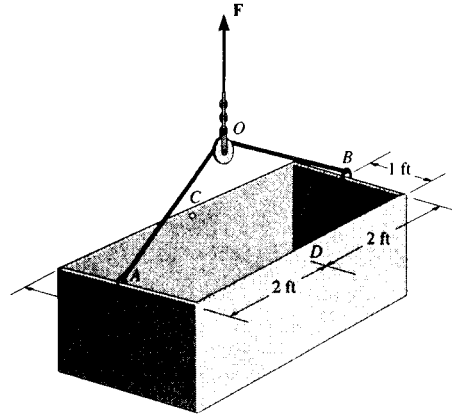

Free Body Diagram : By observation, the force F has to support the entire weight of the tank. Thus, $F = 200$ lb. The tension in cable is the same throughout the cable.

Equations of Equilibrium :

$$\rightarrow \Sigma F_x = 0; \quad T \cos \theta - T \cos \theta = 0 \quad (\text{Satisfied!})$$

$$+ \uparrow \Sigma F_y = 0; \quad 200 - 2T \sin \theta = 0 \quad T = \frac{100}{\sin \theta} \quad [1]$$

From the function obtained above, one realizes that in order to produce the least amount of tension in the cable, $\sin \theta$ hence θ must be as great as possible. Since the attachment of the cable to point C and D produces a greater θ ($\theta = \cos^{-1} \frac{1}{3} = 70.53^\circ$) as compared to the attachment of the cable to points A and B ($\theta = \cos^{-1} \frac{2}{3} = 48.19^\circ$),

The attachment of the cable to point C and D will produce the least amount of tension in the cable. Ans

Thus,

$$T = \frac{100}{\sin 70.53^\circ} = 106 \text{ lb} \quad \text{Ans}$$

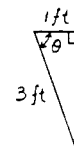
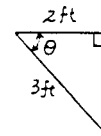
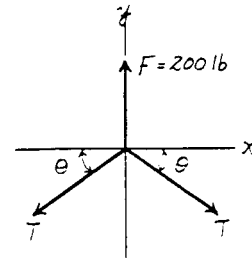

■3-31. A vertical force $P = 10$ lb is applied to the ends of the 2-ft cord AB and spring AC . If the spring has an unstretched length of 2 ft, determine the angle θ for equilibrium. Take $k = 15$ lb/ft.

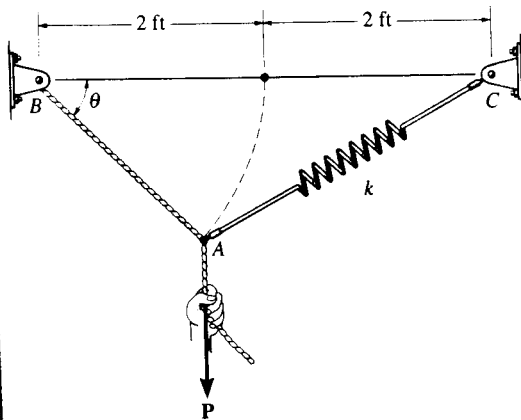

$$\rightarrow \Sigma F_x = 0; \quad F_s \cos \phi - T \cos \theta = 0 \quad (1)$$

$$+\uparrow \Sigma F_y = 0; \quad T \sin \theta + F_s \sin \phi - 10 = 0 \quad (2)$$

$$x = \sqrt{(4)^2 + (2)^2 - 2(4)(2) \cos \theta} = 2\sqrt{5 - 4 \cos \theta}$$

$$F_s = kx = 2k(\sqrt{5 - 4 \cos \theta} - 1)$$

$$\text{From Eq. (1): } T = F_s \left(\frac{\cos \phi}{\cos \theta} \right)$$

$$\text{From Eq. (2): } T = 2k(\sqrt{5 - 4 \cos \theta} - 1) \left(\frac{2 - \cos \theta}{\sqrt{5 - 4 \cos \theta}} \right) \left(\frac{1}{\cos \theta} \right)$$

$$\frac{2k(\sqrt{5 - 4 \cos \theta} - 1)(2 - \cos \theta)}{\sqrt{5 - 4 \cos \theta}} \tan \theta + \frac{2k(\sqrt{5 - 4 \cos \theta} - 1)2 \sin \theta}{2\sqrt{5 - 4 \cos \theta}} = 10$$

$$\frac{(\sqrt{5 - 4 \cos \theta} - 1)(2 \tan \theta - \sin \theta + \sin \theta)}{\sqrt{5 - 4 \cos \theta}} = \frac{10}{2k}$$

$$\frac{\tan \theta (\sqrt{5 - 4 \cos \theta} - 1)}{\sqrt{5 - 4 \cos \theta}} = \frac{10}{4k}$$

$$\text{Set } k = 15 \text{ lb/ft}$$

Solving for θ ,

$$\theta = 35.0^\circ \quad \text{Ans}$$

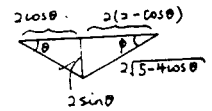
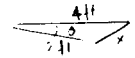
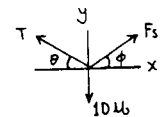

*3-32. Determine the unstretched length of spring AC if a force $P = 80$ lb causes the angle $\theta = 60^\circ$ for equilibrium. Cord AB is 2 ft long. Take $k = 50$ lb/ft.

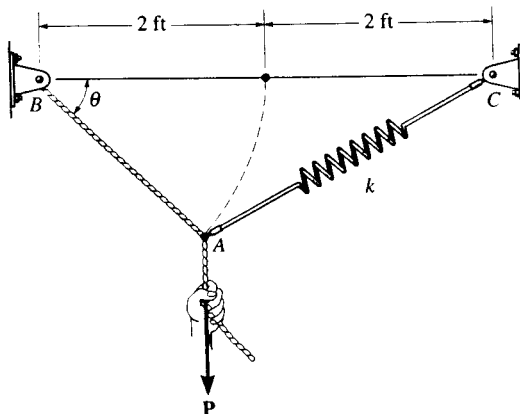

$$l = \sqrt{4^2 + 2^2 - 2(2)(4) \cos 60^\circ}$$

$$l = \sqrt{12}$$

$$\frac{\sqrt{12}}{\sin 60^\circ} = \frac{2}{\sin \phi}$$

$$\phi = \sin^{-1} \left(\frac{2 \sin 60^\circ}{\sqrt{12}} \right) = 30^\circ$$

$$+\uparrow \Sigma F_y = 0; \quad T \sin 60^\circ + F_s \sin 30^\circ - 80 = 0$$

$$\rightarrow \Sigma F_x = 0; \quad -T \cos 60^\circ + F_s \cos 30^\circ = 0$$

Solving for F_s ,

$$F_s = 40 \text{ lb}$$

$$F_s = kx$$

$$40 = 50(\sqrt{12} - l')$$

$$l' = 2.66 \text{ ft} \quad \text{Ans}$$

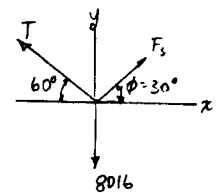
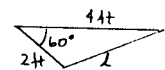

■3-33. A "scale" is constructed with a 4-ft-long cord and the 10-lb block *D*. The cord is fixed to a pin at *A* and passes over two *small* pulleys at *B* and *C*. Determine the weight of the suspended block *E* if the system is in equilibrium when $s = 1.5$ ft.

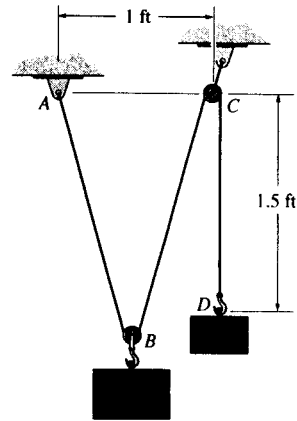

Free Body Diagram : The tension force in the cord is the same throughout the cord, that is 10 lb. From the geometry,

$$\theta = \sin^{-1}\left(\frac{0.5}{1.25}\right) = 23.58^\circ$$

Equations of Equilibrium :

$$\rightarrow \Sigma F_x = 0; \quad 10\sin 23.58^\circ - 10\sin 23.58^\circ = 0 \quad (\text{Satisfied!})$$

$$+ \uparrow \Sigma F_y = 0; \quad 2(10)\cos 23.58^\circ - W_E = 0$$

$$W_E = 18.3 \text{ lb} \quad \text{Ans}$$

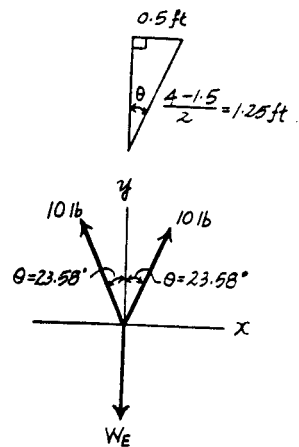

- 3-34. A car is to be towed using the rope arrangement shown. The towing force required is 600 lb. Determine the minimum length l of rope AB so that the tension in either rope AB or AC does not exceed 750 lb. *Hint:* Use the equilibrium condition at point A to determine the required angle θ for attachment, then determine l using trigonometry applied to triangle ABC .

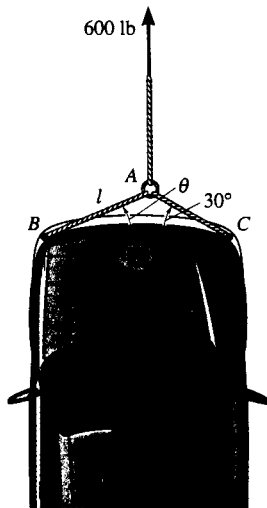

Case 1 : Assume $T_{AC} = 750$ lb

$$\begin{aligned} \rightarrow \Sigma F_x = 0; & \quad 750 \cos 30^\circ - T_{AB} \cos \theta = 0 \\ + \uparrow \Sigma F_y = 0; & \quad 600 - 750 \sin 30^\circ - T_{AB} \sin \theta = 0 \\ & \quad \theta = 19.107^\circ \end{aligned}$$

$$T_{AB} = 687.39 \text{ lb} < 750 \text{ lb} \quad (\text{O.K!})$$

$$\frac{4}{\sin(180^\circ - 30^\circ - 19.107^\circ)} = \frac{l}{\sin 30^\circ}$$

$$l = 2.65 \text{ ft}$$

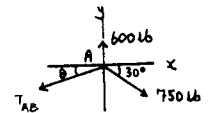

Case 2 : Assume $T_{AB} = 750$ lb

$$\begin{aligned} \rightarrow \Sigma F_x = 0; & \quad T_{AC} \cos 30^\circ - 750 \cos \theta = 0 \\ + \uparrow \Sigma F_y = 0; & \quad 600 - T_{AC} \sin 30^\circ - 750 \sin \theta = 0 \\ & \quad 600 - \frac{750 \cos \theta}{\cos 30^\circ} \sin 30^\circ - 750 \sin \theta = 0 \\ & \quad 433.01 \cos \theta + 750 \sin \theta = 600 \end{aligned}$$

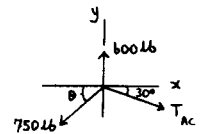

An analytic approach to the solution is as follows :

$$(433.01 \sqrt{1 - \sin^2 \theta})^2 = (600 - 750 \sin \theta)^2$$

$$172\,500 - 900\,000 \sin \theta + 750\,000 \sin^2 \theta = 0$$

Solving this quadratic equation for the root of θ that gives a positive value for T_{AC} we get

$$\theta = 13.854^\circ$$

$$T_{AC} = \frac{750 \cos 13.854^\circ}{\cos 30^\circ}$$

$$T_{AC} = 840.83 \text{ lb} > 750 \text{ lb} \quad (\text{N.G!})$$

Thus, $l = 2.65 \text{ ft}$ Ans

*3-35. The spring has a stiffness of $k = 800 \text{ N/m}$ and an unstretched length of 200 mm . Determine the force in cables BC and BD when the spring is held in the position shown.

The Force in The Spring : The spring stretches $s = l - l_0 = 0.5 - 0.2 = 0.3 \text{ m}$. Applying Eq. 3-2, we have

$$F_p = ks = 800(0.3) = 240 \text{ N}$$

Equations of Equilibrium :

$$\begin{aligned} \rightarrow \Sigma F_x = 0; \quad F_{BC} \cos 45^\circ + F_{BD} \left(\frac{4}{5}\right) - 240 = 0 \\ 0.7071 F_{BC} + 0.8 F_{BD} = 240 \end{aligned} \quad [1]$$

$$\begin{aligned} + \uparrow \Sigma F_y = 0; \quad F_{BC} \sin 45^\circ - F_{BD} \left(\frac{3}{5}\right) = 0 \\ F_{BC} = 0.8485 F_{BD} \end{aligned} \quad [2]$$

Solving Eqs. [1] and [2] yields,

$$F_{BD} = 171 \text{ N} \quad F_{BC} = 145 \text{ N} \quad \text{Ans}$$

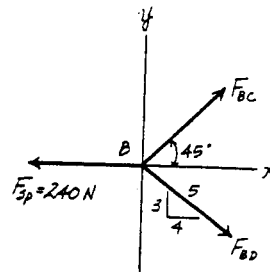
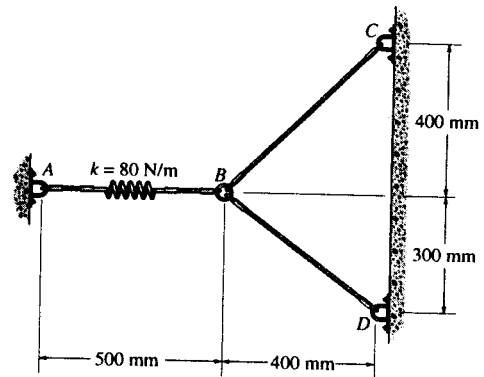

*3-36. The sling BAC is used to lift the 100-lb load with constant velocity. Determine the force in the sling and plot its value T (ordinate) as a function of its orientation θ , $+ \uparrow \Sigma F_y = 0$; where $0 \leq \theta \leq 90^\circ$.

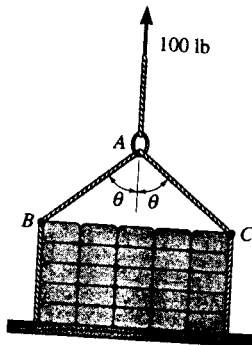

$$100 - 2T \cos \theta = 0$$

$$T = \frac{50}{\cos \theta} \quad \text{Ans}$$

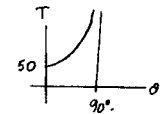
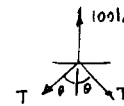

■3-37. The 10-lb lamp fixture is suspended from two springs, each having an unstretched length of 4 ft and stiffness of $k = 5 \text{ lb/ft}$. Determine the angle θ for equilibrium.

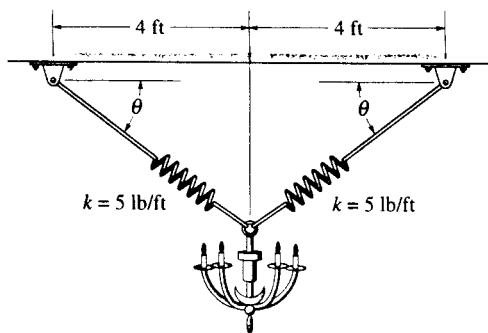

$$\begin{aligned} \rightarrow \Sigma F_x &= 0; & T \cos \theta - T \cos \theta &= 0 \\ + \uparrow \Sigma F_y &= 0; & 2T \sin \theta - 10 &= 0 \\ & & T \sin \theta &= 5 \text{ lb} \\ F &= ks; & T &= 5 \left(\frac{4}{\cos \theta} - 4 \right) \\ & & T &= 20 \left(\frac{1}{\cos \theta} - 1 \right) \\ 20 \left(\frac{\sin \theta}{\cos \theta} - \sin \theta \right) &= 5 \\ \tan \theta - \sin \theta &= 0.25 \end{aligned}$$

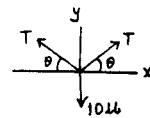

Solving by trial and error,

$$\theta = 43.0^\circ \quad \text{Ans}$$

■3-38. The pail and its contents have a mass of 60 kg. If the cable is 15 m long, determine the distance y of the pulley for equilibrium. Neglect the size of the pulley at A .

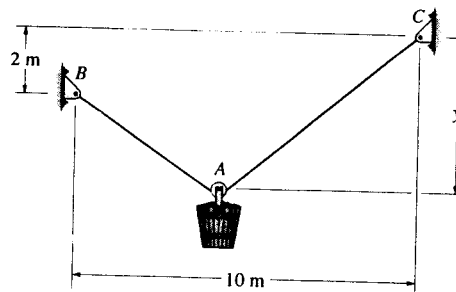

Free Body Diagram : Since the pulley is smooth, the tension in the cable is the same throughout the cable.

Equations of Equilibrium :

$$\rightarrow \Sigma F_x = 0; \quad T \sin \theta - T \sin \phi = 0 \quad \theta = \phi$$

Geometry :

$$l_1 = \sqrt{(10-x)^2 + (y-2)^2} \quad l_2 = \sqrt{x^2 + y^2}$$

Since $\theta = \phi$, two triangles are similar.

$$\frac{10-x}{x} = \frac{y-2}{y} = \frac{\sqrt{(10-x)^2 + (y-2)^2}}{\sqrt{x^2 + y^2}}$$

Also,

$$\begin{aligned} l_1 + l_2 &= 15 \\ \sqrt{(10-x)^2 + (y-2)^2} + \sqrt{x^2 + y^2} &= 15 \\ \left(\frac{\sqrt{x^2 + y^2}}{\sqrt{x^2 + y^2}} \right) \sqrt{(10-x)^2 + (y-2)^2} + \sqrt{x^2 + y^2} &= 15 \end{aligned}$$

However, from Eq. [1] $\frac{\sqrt{(10-x)^2 + (y-2)^2}}{\sqrt{x^2 + y^2}} = \frac{10-x}{x}$, Eq. [2] becomes

$$\sqrt{x^2 + y^2} \left(\frac{10-x}{x} \right) + \sqrt{x^2 + y^2} = 15$$

Dividing both sides of Eq. [3] by $\sqrt{x^2 + y^2}$ yields

$$\frac{10}{x} = \frac{15}{\sqrt{x^2 + y^2}} \quad x = \sqrt{0.8y} \quad [4]$$

From Eq. [1] $\frac{10-x}{x} = \frac{y-2}{y} \quad x = \frac{5y}{y-1} \quad [5]$

Equating Eq. [1] and [5] yields

$$\begin{aligned} \sqrt{0.8y} &= \frac{5y}{y-1} \\ y &= 6.59 \text{ m} \end{aligned}$$

Ans

[1]

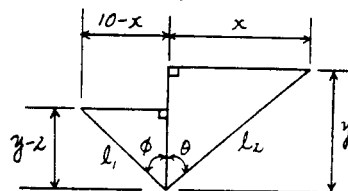

[2]

[3]

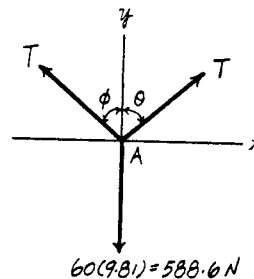

3-39. A 4-kg sphere rests on the smooth parabolic surface. Determine the normal force it exerts on the surface and the mass m_B of block B needed to hold it in the equilibrium position shown.

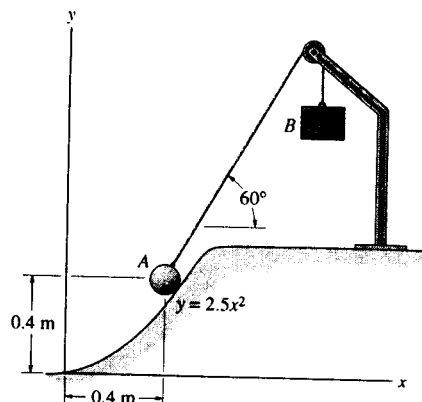

Geometry : The angle θ which the surface make with the horizontal is to be determined first.

$$\tan \theta \Big|_{x=0.4\text{m}} = \frac{dy}{dx} \Big|_{x=0.4\text{m}} = 5.0x \Big|_{x=0.4\text{m}} = 2.00$$

$$\theta = 63.43^\circ$$

Free Body Diagram : The tension in the cord is the same throughout the cord and is equal to the weight of block B , $W_B = m_B (9.81)$.

Equations of Equilibrium :

$$\rightarrow \Sigma F_x = 0; \quad m_B (9.81) \cos 60^\circ - N \sin 63.43^\circ = 0$$

$$N = 5.4840m_B \quad [1]$$

$$+ \uparrow \Sigma F_y = 0; \quad m_B (9.81) \sin 60^\circ + N \cos 63.43^\circ - 39.24 = 0$$

$$8.4957m_B + 0.4472N = 39.24 \quad [2]$$

Solving Eqs. [1] and [2] yields

$$m_B = 3.58 \text{ kg} \quad N = 19.7 \text{ N} \quad \text{Ans}$$

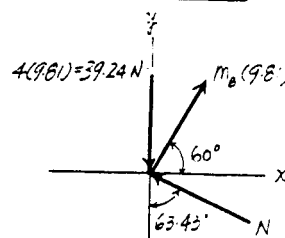
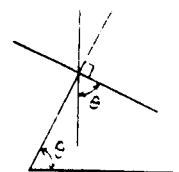

*3-40. The 30-kg pipe is supported at A by a system of five cords. Determine the force in each cord for equilibrium.

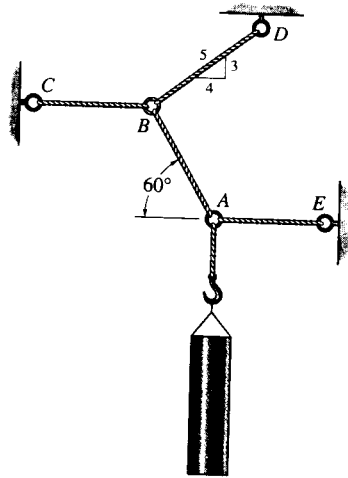

$$+\uparrow \Sigma F_y = 0; \quad T_{AB} \sin 60^\circ - 30(9.81) = 0$$

$$T_{AB} = 339.83 = 340 \text{ N} \quad \text{Ans}$$

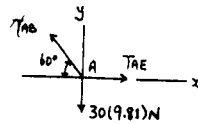

$$\rightarrow \Sigma F_x = 0; \quad T_{AE} - 339.83 \cos 60^\circ = 0$$

$$T_{AE} = 170 \text{ N} \quad \text{Ans}$$

$$+\uparrow \Sigma F_y = 0; \quad T_{BD} \left(\frac{3}{5}\right) - 339.83 \sin 60^\circ = 0$$

$$T_{BD} = 490.5 = 490 \text{ N} \quad \text{Ans}$$

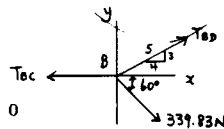

$$\rightarrow \Sigma F_x = 0; \quad 490.5 \left(\frac{4}{5}\right) + 339.83 \cos 60^\circ - T_{BC} = 0$$

$$T_{BC} = 562 \text{ N} \quad \text{Ans}$$

3-41. Determine the magnitude and direction of F_1 required to keep the concurrent force system in equilibrium.

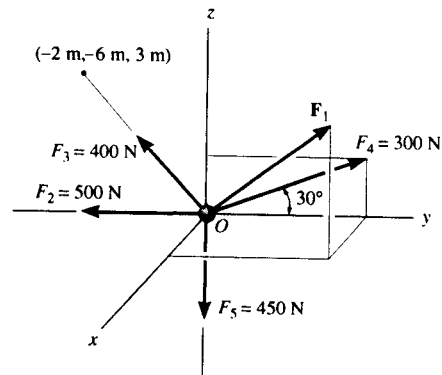

Cartesian Vector Notation :

$$F_1 = F_{1x}i + F_{1y}j + F_{1z}k$$

$$F_2 = \{-500j\} \text{ N}$$

$$F_3 = 400 \left(\frac{-2i - 6j + 3k}{\sqrt{(-2)^2 + (-6)^2 + 3^2}} \right) = \{-114.29i - 342.86j + 171.43k\} \text{ N}$$

$$F_4 = 300\{\cos 30^\circ j + \sin 30^\circ k\} \text{ N} = \{259.81j + 150.0k\} \text{ N}$$

$$F_5 = \{-450k\} \text{ N}$$

Equations of Equilibrium :

$$\Sigma F = 0; \quad F_1 + F_2 + F_3 + F_4 + F_5 = 0$$

$$\begin{aligned} (F_{1x} - 114.29)i + (F_{1y} - 500 - 342.86 + 259.81)j \\ + (F_{1z} + 171.43 + 150.0 - 450)k = 0 \end{aligned}$$

Equating i, j and k components, we have

$$F_{1x} - 114.29 = 0 \qquad F_{1x} = 114.29 \text{ N}$$

$$F_{1y} - 500 - 342.86 + 259.81 = 0 \qquad F_{1y} = 583.05 \text{ N}$$

$$F_{1z} + 171.43 + 150.0 - 450 = 0 \qquad F_{1z} = 128.57 \text{ N}$$

The magnitude of F_1 is

$$\begin{aligned} F_1 &= \sqrt{F_{1x}^2 + F_{1y}^2 + F_{1z}^2} \\ &= \sqrt{114.29^2 + 583.05^2 + 128.57^2} \\ &= 607.89 \text{ N} = 608 \text{ N} \end{aligned} \qquad \text{Ans}$$

The coordinate direction angles are

$$\alpha = \cos^{-1} \left(\frac{F_{1x}}{F_1} \right) = \cos^{-1} \left(\frac{114.29}{607.89} \right) = 79.2^\circ \qquad \text{Ans}$$

$$\beta = \cos^{-1} \left(\frac{F_{1y}}{F_1} \right) = \cos^{-1} \left(\frac{583.05}{607.89} \right) = 16.4^\circ \qquad \text{Ans}$$

$$\gamma = \cos^{-1} \left(\frac{F_{1z}}{F_1} \right) = \cos^{-1} \left(\frac{128.57}{607.89} \right) = 77.8^\circ \qquad \text{Ans}$$

3-42. Determine the magnitudes of F_1 , F_2 , and F_3 for equilibrium of the particle.

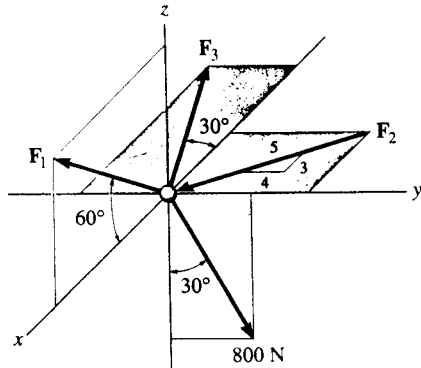

$$F_1 = F_1 (\cos 60^\circ \mathbf{i} + \sin 60^\circ \mathbf{k})$$

$$= \{0.5F_1 \mathbf{i} + 0.8660F_1 \mathbf{k}\} \text{ N}$$

$$F_2 = F_2 \left(\frac{3}{5} \mathbf{i} - \frac{4}{5} \mathbf{j}\right)$$

$$= \{0.6F_2 \mathbf{i} - 0.8F_2 \mathbf{j}\} \text{ N}$$

$$F_3 = F_3 \{-\cos 30^\circ \mathbf{i} - \sin 30^\circ \mathbf{j}\}$$

$$\{-0.8660F_3 \mathbf{i} - 0.5F_3 \mathbf{j}\} \text{ N}$$

$$\Sigma F_x = 0; \quad 0.5F_1 + 0.6F_2 - 0.8660F_3 = 0$$

$$\Sigma F_y = 0; \quad -0.8F_2 - 0.5F_3 + 800 \sin 30^\circ = 0$$

$$\Sigma F_z = 0; \quad 0.8660F_1 - 800 \cos 30^\circ = 0$$

$$F_1 = 800 \text{ N} \quad \text{Ans}$$

$$F_2 = 147 \text{ N} \quad \text{Ans}$$

$$F_3 = 564 \text{ N} \quad \text{Ans}$$

3-43. Determine the magnitudes of F_1 , F_2 , and F_3 for equilibrium of the particle.

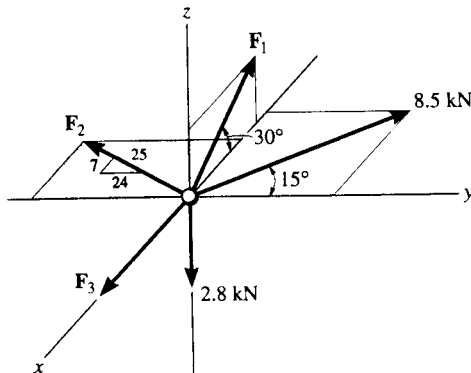

$$\Sigma F_z = 0; \quad F_1 \sin 30^\circ - 2.8 = 0$$

$$F_1 = 5.60 \text{ kN} \quad \text{Ans}$$

$$\Sigma F_y = 0; \quad 8.5 \cos 15^\circ - \left(\frac{24}{25}\right)F_2 = 0$$

$$F_2 = 8.55 \text{ kN} \quad \text{Ans}$$

$$\Sigma F_x = 0; \quad F_3 - 5.6 \cos 30^\circ - 8.55 \left(\frac{7}{25}\right) - 8.5 \sin 15^\circ = 0$$

$$F_3 = 9.44 \text{ kN} \quad \text{Ans}$$

≡*3-44. Determine the magnitude and direction of the force **P** required to keep the concurrent force system in equilibrium.

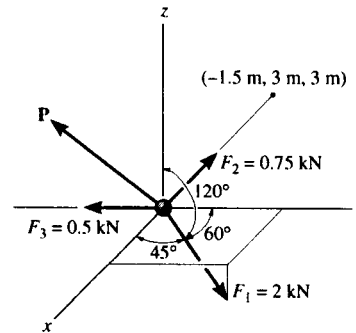

Cartesian Vector Notation :

$$F_1 = 2\{\cos 45^\circ i + \cos 60^\circ j + \cos 120^\circ k\} \text{ kN} = \{1.414i + 1.00j - 1.00k\} \text{ kN}$$

$$F_2 = 0.75 \left(\frac{-1.5i + 3j + 3k}{\sqrt{(-1.5)^2 + 3^2 + 3^2}} \right) = \{-0.250i + 0.50j + 0.50k\} \text{ kN}$$

$$F_3 = \{-0.50j\} \text{ kN}$$

$$P = P_x i + P_y j + P_z k$$

Equations of Equilibrium :

$$\Sigma F = 0; \quad F_1 + F_2 + F_3 + P = 0$$

$$(P_x + 1.414 - 0.250)i + (P_y + 1.00 + 0.50 - 0.50)j + (P_z - 1.00 + 0.50)k = 0$$

Equating i, j and k components, we have

$$\begin{aligned} P_x + 1.414 - 0.250 &= 0 & P_x &= -1.164 \text{ kN} \\ P_y + 1.00 + 0.50 - 0.50 &= 0 & P_y &= -1.00 \text{ kN} \\ P_z - 1.00 + 0.50 &= 0 & P_z &= 0.500 \text{ kN} \end{aligned}$$

The magnitude of F_1 is

$$\begin{aligned} P &= \sqrt{P_x^2 + P_y^2 + P_z^2} \\ &= \sqrt{(-1.164)^2 + (-1.00)^2 + (0.500)^2} \\ &= 1.614 \text{ kN} = 1.61 \text{ kN} \end{aligned} \quad \text{Ans}$$

The coordinate direction angles are

$$\alpha = \cos^{-1} \left(\frac{P_x}{P} \right) = \cos^{-1} \left(\frac{-1.164}{1.614} \right) = 136^\circ \quad \text{Ans}$$

$$\beta = \cos^{-1} \left(\frac{P_y}{P} \right) = \cos^{-1} \left(\frac{-1.00}{1.614} \right) = 128^\circ \quad \text{Ans}$$

$$\gamma = \cos^{-1} \left(\frac{P_z}{P} \right) = \cos^{-1} \left(\frac{0.500}{1.614} \right) = 72.0^\circ \quad \text{Ans}$$

3-45. The three cables are used to support the 800-N lamp. Determine the force developed in each cable for equilibrium.

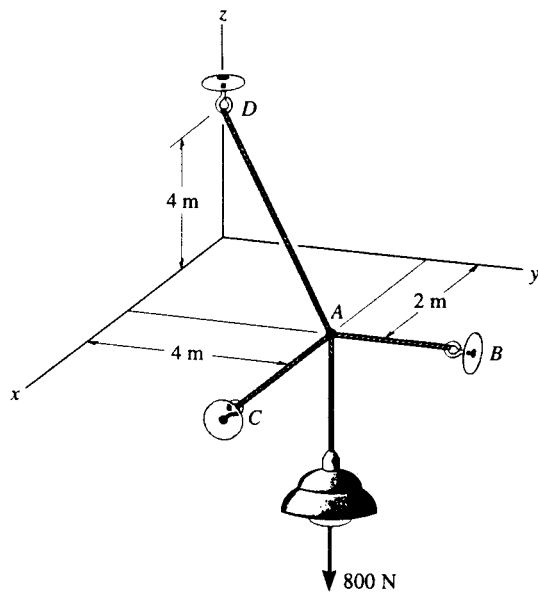

$$\Sigma F_z = 0; \quad \frac{4}{6} F_{AD} - 800 = 0$$

$$F_{AD} = 1.20 \text{ kN} \quad \text{Ans}$$

$$\Sigma F_x = 0; \quad -\frac{2}{6}(1200) + F_{AC} = 0$$

$$F_{AC} = 0.40 \text{ kN} \quad \text{Ans}$$

$$\Sigma F_y = 0; \quad -\left(\frac{4}{6}\right)(1200) + F_{AB} = 0$$

$$F_{AB} = 0.80 \text{ kN} \quad \text{Ans}$$

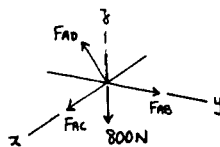

3-46. If cable AB is subjected to a tension of 700 N, determine the tension in cables AC and AD and the magnitude of the vertical force F .

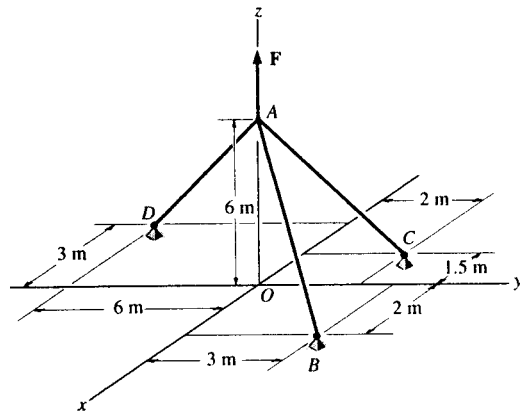

Cartesian Vector Notation :

$$F_{AB} = 700 \left(\frac{2i + 3j - 6k}{\sqrt{2^2 + 3^2 + (-6)^2}} \right) = \{200i + 300j - 600k\} \text{ N}$$

$$F_{AC} = F_{AC} \left(\frac{-1.5i + 2j - 6k}{\sqrt{(-1.5)^2 + 2^2 + (-6)^2}} \right) = -0.2308F_{AC}i + 0.3077F_{AC}j - 0.9231F_{AC}k$$

$$F_{AD} = F_{AD} \left(\frac{-3i - 6j - 6k}{\sqrt{(-3)^2 + (-6)^2 + (-6)^2}} \right) = -0.3333F_{AD}i - 0.6667F_{AD}j - 0.6667F_{AD}k$$

$$F = Fk$$

Equations of Equilibrium :

$$\Sigma F = 0; \quad F_{AB} + F_{AC} + F_{AD} + F = 0$$

$$(200 - 0.2308F_{AC} - 0.3333F_{AD})i + (300 + 0.3077F_{AC} - 0.6667F_{AD})j + (-600 - 0.9231F_{AC} - 0.6667F_{AD} + F)k = 0$$

Equating i, j and k components, we have

$$200 - 0.2308F_{AC} - 0.3333F_{AD} = 0 \quad [1]$$

$$300 + 0.3077F_{AC} - 0.6667F_{AD} = 0 \quad [2]$$

$$-600 - 0.9231F_{AC} - 0.6667F_{AD} + F = 0 \quad [3]$$

Solving Eqs. [1], [2] and [3] yields

$$F_{AC} = 130 \text{ N} \quad F_{AD} = 510 \text{ N} \quad F = 1060 \text{ N} = 1.06 \text{ kN} \quad \text{Ans}$$

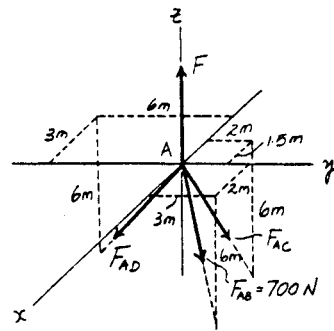

3-47. Determine the stretch in each of the two springs required to hold the 20-kg crate in the equilibrium position shown. Each spring has an unstretched length of 2 m and a stiffness of $k = 300 \text{ N/m}$.

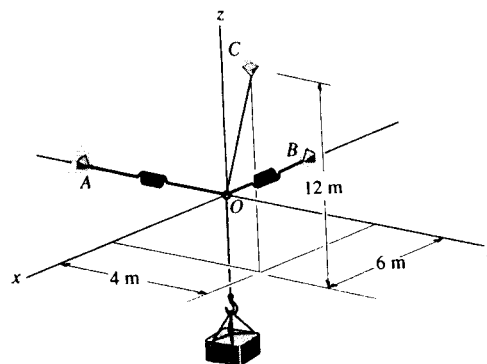

Cartesian Vector Notation :

$$F_{OC} = F_{OC} \left(\frac{6i + 4j + 12k}{\sqrt{6^2 + 4^2 + 12^2}} \right) = \frac{3}{7}F_{OC}i + \frac{2}{7}F_{OC}j + \frac{6}{7}F_{OC}k$$

$$F_{OA} = -F_{OA}j \quad F_{OB} = -F_{OB}i$$

$$F = (-196.2k) \text{ N}$$

Equations of Equilibrium :

$$\Sigma F = 0; \quad F_{OC} + F_{OA} + F_{OB} + F = 0$$

$$\left(\frac{3}{7}F_{OC} - F_{OB} \right) i + \left(\frac{2}{7}F_{OC} - F_{OA} \right) j + \left(\frac{6}{7}F_{OC} - 196.2 \right) k = 0$$

Equating i, j and k components, we have

$$\frac{3}{7}F_{OC} - F_{OB} = 0 \quad [1]$$

$$\frac{2}{7}F_{OC} - F_{OA} = 0 \quad [2]$$

$$\frac{6}{7}F_{OC} - 196.2 = 0 \quad [3]$$

Solving Eqs. [1], [2] and [3] yields

$$F_{OC} = 228.9 \text{ N} \quad F_{OB} = 98.1 \text{ N} \quad F_{OA} = 65.4 \text{ N}$$

Spring Elongation : Using spring formula, Eq. 3-2, the spring elongation is $s = \frac{F}{k}$.

$$s_{OB} = \frac{98.1}{300} = 0.327 \text{ m} = 327 \text{ mm} \quad \text{Ans}$$

$$s_{OA} = \frac{65.4}{300} = 0.218 \text{ m} = 218 \text{ mm} \quad \text{Ans}$$

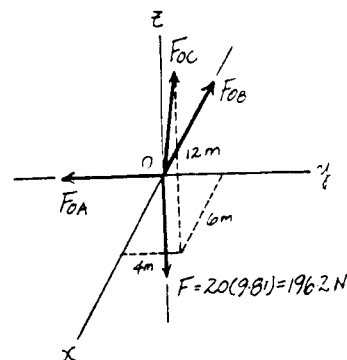

*3-48. If the bucket and its contents have a total weight of 20 lb, determine the force in the supporting cables DA, DB, and DC.

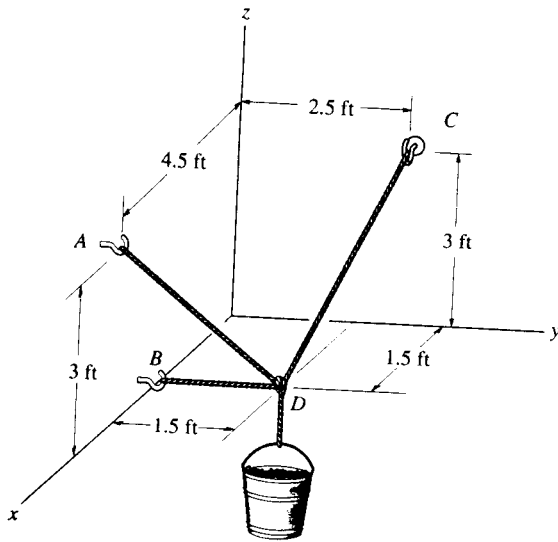

$$u_{DA} = \left\{ \frac{3}{4.5}i - \frac{1.5}{4.5}j + \frac{3}{4.5}k \right\}$$

$$u_{DC} = \left\{ -\frac{1.5}{3.5}i + \frac{1}{3.5}j + \frac{3}{3.5}k \right\}$$

$$\Sigma F_x = 0; \quad \frac{3}{4.5}F_{DA} - \frac{1.5}{3.5}F_{DC} = 0$$

$$\Sigma F_y = 0; \quad -\frac{1.5}{4.5}F_{DA} - F_{DB} + \frac{1}{3.5}F_{DC} = 0$$

$$\Sigma F_z = 0; \quad \frac{3}{4.5}F_{DA} + \frac{3}{3.5}F_{DC} - 20 = 0$$

$$F_{DA} = 10.0 \text{ lb} \quad \text{Ans}$$

$$F_{DB} = 1.11 \text{ lb} \quad \text{Ans}$$

$$F_{DC} = 15.6 \text{ lb} \quad \text{Ans}$$

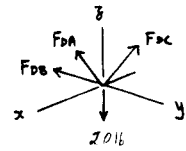

3-49. The 2500-N crate is to be hoisted with constant velocity from the hold of a ship using the cable arrangement shown. Determine the tension in each of the three cables for equilibrium.

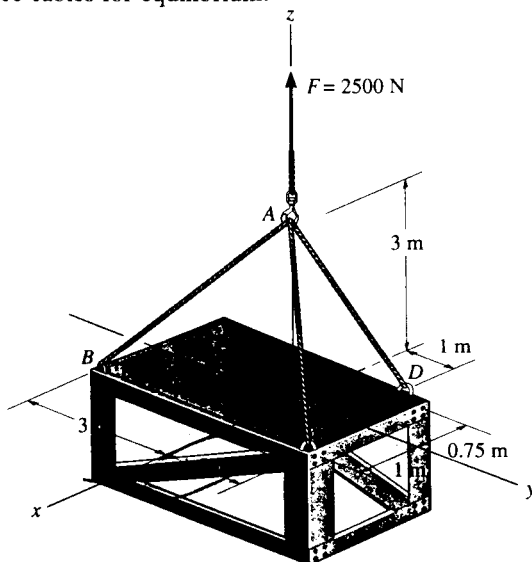

$$F_{AD} = F_{AD} \left(\frac{-0.75i + j - 3k}{\sqrt{(-0.75)^2 + 1^2 + (-3)^2}} \right) = -0.2308F_{AD}i + 0.3077F_{AD}j - 0.9231F_{AD}k$$

$$F_{AC} = F_{AC} \left(\frac{1i + 1.5j - 3k}{\sqrt{1^2 + 1.5^2 + (-3)^2}} \right) = 0.2857F_{AC}i + 0.4286F_{AC}j - 0.8571F_{AC}k$$

$$F_{AB} = F_{AB} \left(\frac{1i - 3j - 3k}{\sqrt{1^2 + (-3)^2 + (-3)^2}} \right) = 0.2294F_{AB}i - 0.6882F_{AB}j - 0.6882F_{AB}k$$

$$F = \{2.5k\} \text{ kN}$$

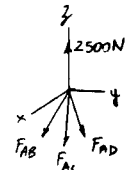

$$\begin{aligned} \Sigma F = 0; \quad & F_{AD} + F_{AB} + F_{AC} + F = 0 \\ & (-0.2308F_{AD}i + 0.3077F_{AD}j - 0.9231F_{AD}k) \\ & + (0.2294F_{AB}i - 0.6882F_{AB}j - 0.6882F_{AB}k) \\ & + (0.2857F_{AC}i + 0.4286F_{AC}j - 0.8571F_{AC}k) + (2.5k) = 0 \\ & (-0.2308F_{AD} + 0.2294F_{AB} + 0.2857F_{AC})i \\ & + (0.3077F_{AD} - 0.6882F_{AB} + 0.4286F_{AC})j \\ & + (-0.9231F_{AD} - 0.6882F_{AB} - 0.8571F_{AC} + 2.5)k = 0 \end{aligned}$$

$$\Sigma F_x = 0; \quad -0.2308F_{AD} + 0.2294F_{AB} + 0.2857F_{AC} = 0 \quad [1]$$

$$\Sigma F_y = 0; \quad 0.3077F_{AD} - 0.6882F_{AB} + 0.4286F_{AC} = 0 \quad [2]$$

$$\Sigma F_z = 0; \quad -0.9231F_{AD} - 0.6882F_{AB} - 0.8571F_{AC} + 2.5 = 0 \quad [3]$$

Solving Eqs. [1], [2] and [3] yields :

$$F_{AB} = 0.980 \text{ kN} \quad F_{AC} = 0.463 \text{ kN} \quad F_{AD} = 1.55 \text{ kN} \quad \text{Ans}$$

■3-50. The lamp has a mass of 15 kg and is supported by a pole AO and cables AB and AC . If the force in the pole acts along its axis, determine the forces in AO , AB , and AC for equilibrium.

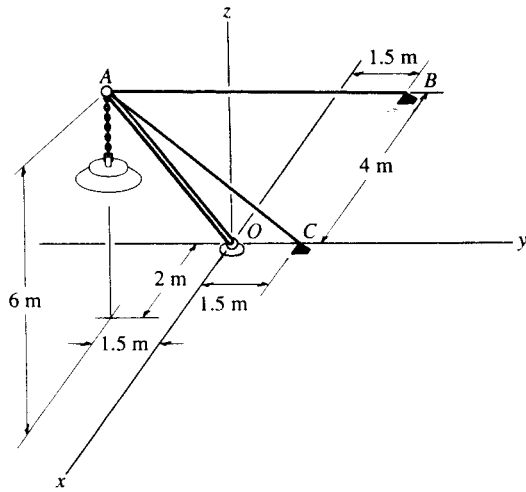

$$\mathbf{F}_{AO} = F_{AO} \left\{ \frac{2}{6.5}\mathbf{i} - \frac{1.5}{6.5}\mathbf{j} + \frac{6}{6.5}\mathbf{k} \right\} \text{ N}$$

$$\mathbf{F}_{AB} = F_{AB} \left\{ -\frac{6}{9}\mathbf{i} + \frac{3}{9}\mathbf{j} - \frac{6}{9}\mathbf{k} \right\} \text{ N}$$

$$\mathbf{F}_{AC} = F_{AC} \left\{ -\frac{2}{7}\mathbf{i} + \frac{3}{7}\mathbf{j} - \frac{6}{7}\mathbf{k} \right\} \text{ N}$$

$$\mathbf{W} = 15(9.81)\mathbf{k} = \{-147.15\mathbf{k}\} \text{ N}$$

$$\Sigma F_x = 0; \quad 0.3077F_{AO} - 0.6667F_{AB} - 0.2857F_{AC} = 0$$

$$\Sigma F_y = 0; \quad -0.2308F_{AO} + 0.3333F_{AB} + 0.4286F_{AC} = 0$$

$$\Sigma F_z = 0; \quad 0.9231F_{AO} - 0.667F_{AB} - 0.8571F_{AC} - 147.15 = 0$$

$$F_{AO} = 319 \text{ N} \quad \text{Ans}$$

$$F_{AB} = 110 \text{ N} \quad \text{Ans}$$

$$F_{AC} = 85.8 \text{ N} \quad \text{Ans}$$

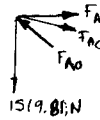

3-51. Cables AB and AC can sustain a maximum tension of 500 N, and the pole can support a maximum compression of 300 N. Determine the maximum weight of the lamp that can be supported in the position shown. The force in the pole acts along the axis of the pole.

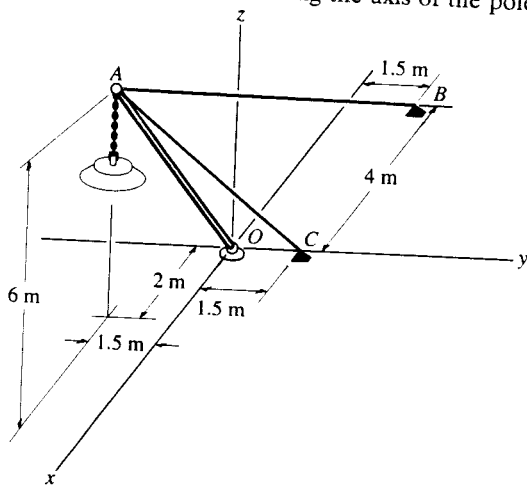

$$F_{AO} = F_{AO} \left(\frac{2}{6.5}i - \frac{1.5}{6.5}j + \frac{6}{6.5}k \right) \text{ N}$$

$$F_{AB} = F_{AB} \left(-\frac{6}{9}i + \frac{3}{9}j - \frac{6}{9}k \right) \text{ N}$$

$$F_{AC} = F_{AC} \left(-\frac{2}{7}i + \frac{3}{7}j - \frac{6}{7}k \right) \text{ N}$$

$$W = \{-Wk\} \text{ N}$$

$$\Sigma F_x = 0; \quad \frac{2}{6.5}F_{AO} - \frac{6}{9}F_{AB} - \frac{2}{7}F_{AC} = 0$$

$$\Sigma F_y = 0; \quad -\frac{1.5}{6.5}F_{AO} + \frac{3}{9}F_{AB} + \frac{3}{7}F_{AC} = 0$$

$$\Sigma F_z = 0; \quad \frac{6}{6.5}F_{AO} - \frac{6}{9}F_{AB} - \frac{6}{7}F_{AC} - W = 0$$

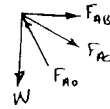

1) Assume $F_{AB} = 500 \text{ N}$

$$\frac{2}{6.5}F_{AO} - \frac{6}{9}(500) - \frac{2}{7}F_{AC} = 0$$

$$-\frac{1.5}{6.5}F_{AO} + \frac{3}{9}(500) + \frac{3}{7}F_{AC} = 0$$

$$\frac{6}{6.5}F_{AO} - \frac{6}{9}(500) - \frac{6}{7}F_{AC} - W = 0$$

Solving,

$$F_{AO} = 1444.462 \text{ N} > 300 \text{ N (N.G!)}$$

$$F_{AC} = 388.902 \text{ N}$$

$$W = 666.677 \text{ N}$$

2) Assume $F_{AC} = 500 \text{ N}$

$$\frac{2}{6.5}F_{AO} - \frac{6}{9}F_{AB} - \frac{2}{7}(500) = 0$$

$$-\frac{1.5}{6.5}F_{AO} + \frac{3}{9}F_{AB} + \frac{3}{7}(500) = 0$$

$$\frac{6}{6.5}F_{AO} - \frac{6}{9}F_{AB} - \frac{6}{7}(500) - W = 0$$

Solving,

$$F_{AO} = 1857.143 \text{ N} > 300 \text{ N (N.G!)}$$

$$F_{AB} = 642.857 \text{ N} > 500 \text{ N (N.G!)}$$

3) Assume $F_{AO} = 300 \text{ N}$

$$\frac{2}{6.5}(300) - \frac{6}{9}F_{AB} - \frac{2}{7}F_{AC} = 0$$

$$-\frac{1.5}{6.5}(300) + \frac{3}{9}F_{AB} + \frac{3}{7}F_{AC} = 0$$

$$\frac{6}{6.5}(300) - \frac{6}{9}F_{AB} - \frac{6}{7}F_{AC} - W = 0$$

Solving,

$$F_{AC} = 80.8 \text{ N}$$

$$F_{AB} = 104 \text{ N}$$

$$W = 138 \text{ N} \quad \text{Ans}$$

*3-52. Determine the tension in cables AB , AC , and AD , required to hold the 60-lb crate in equilibrium.

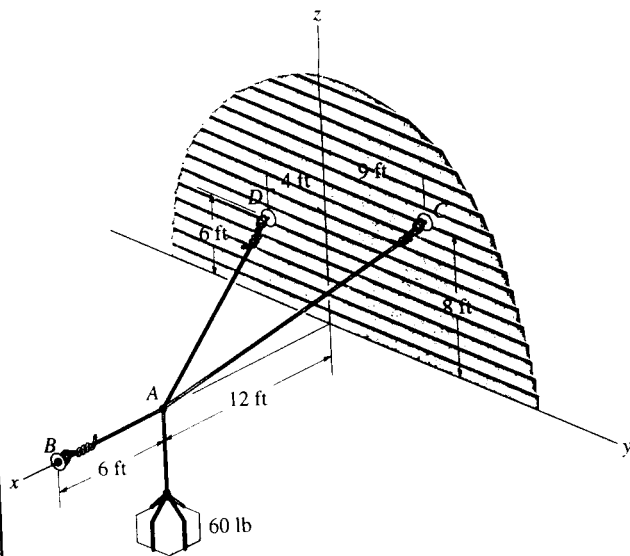

$$W = -60\mathbf{k}$$

$$T_B = T_B\mathbf{i}$$

$$T_C = T_C\left(-\frac{12}{17}\mathbf{i} + \frac{9}{17}\mathbf{j} + \frac{8}{17}\mathbf{k}\right)$$

$$= -0.706T_C\mathbf{i} + 0.529T_C\mathbf{j} + 0.471T_C\mathbf{k}$$

$$T_D = T_D\left(-\frac{12}{14}\mathbf{i} - \frac{4}{14}\mathbf{j} + \frac{6}{14}\mathbf{k}\right)$$

$$= -0.857T_D\mathbf{i} - 0.286T_D\mathbf{j} + 0.429T_D\mathbf{k}$$

$$\Sigma F_x = 0; \quad T_B - 0.706T_C - 0.857T_D = 0$$

$$\Sigma F_y = 0; \quad 0.529T_C - 0.286T_D = 0$$

$$\Sigma F_z = 0; \quad -60 + 0.471T_C + 0.429T_D = 0$$

Solving,

$$T_B = 109 \text{ lb} \quad \text{Ans}$$

$$T_C = 47.4 \text{ lb} \quad \text{Ans}$$

$$T_D = 87.9 \text{ lb} \quad \text{Ans}$$

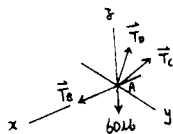

3-53. The boom supports a bucket and contents, which have a total mass of 300 kg. Determine the forces developed in struts AD and AE and the tension in cable AB for equilibrium. The force in each strut acts along its axis.

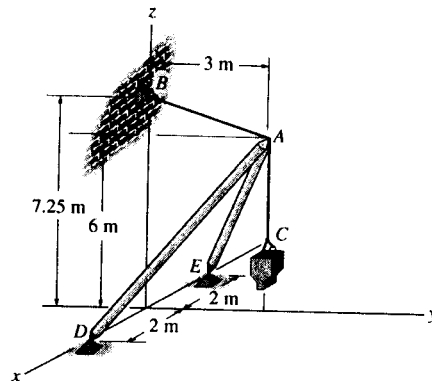

Cartesian Vector Notation :

$$F_{AB} = F_{AB} \left(\frac{-3\mathbf{j} + 1.25\mathbf{k}}{\sqrt{(-3)^2 + 1.25^2}} \right) = -\frac{12}{13}F_{AB}\mathbf{j} + \frac{5}{13}F_{AB}\mathbf{k}$$

$$F_{AD} = F_{AD} \left(\frac{-2\mathbf{i} + 3\mathbf{j} + 6\mathbf{k}}{\sqrt{(-2)^2 + 3^2 + 6^2}} \right) = -\frac{2}{7}F_{AD}\mathbf{i} + \frac{3}{7}F_{AD}\mathbf{j} + \frac{6}{7}F_{AD}\mathbf{k}$$

$$F_{AE} = F_{AE} \left(\frac{2\mathbf{i} + 3\mathbf{j} + 6\mathbf{k}}{\sqrt{2^2 + 3^2 + 6^2}} \right) = \frac{2}{7}F_{AE}\mathbf{i} + \frac{3}{7}F_{AE}\mathbf{j} + \frac{6}{7}F_{AE}\mathbf{k}$$

$$\mathbf{F} = (-2943\mathbf{k}) \text{ N}$$

Equations of Equilibrium :

$$\Sigma \mathbf{F} = 0; \quad F_{AB} + F_{AD} + F_{AE} + \mathbf{F} = 0$$

$$\left(-\frac{2}{7}F_{AD} + \frac{2}{7}F_{AE} \right) \mathbf{i} + \left(-\frac{12}{13}F_{AB} + \frac{3}{7}F_{AD} + \frac{3}{7}F_{AE} \right) \mathbf{j} + \left(\frac{5}{13}F_{AB} + \frac{6}{7}F_{AD} + \frac{6}{7}F_{AE} - 2943 \right) \mathbf{k} = 0$$

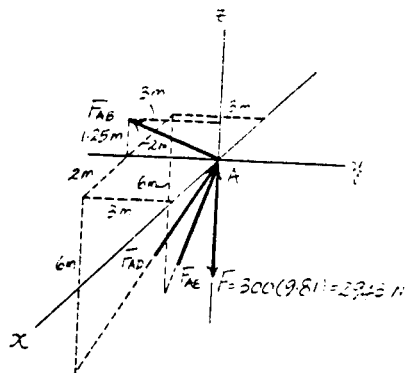

Equating \mathbf{i} , \mathbf{j} and \mathbf{k} components, we have

$$-\frac{2}{7}F_{AD} + \frac{2}{7}F_{AE} = 0 \quad [1]$$

$$-\frac{12}{13}F_{AB} + \frac{3}{7}F_{AD} + \frac{3}{7}F_{AE} = 0 \quad [2]$$

$$\frac{5}{13}F_{AB} + \frac{6}{7}F_{AD} + \frac{6}{7}F_{AE} - 2943 = 0 \quad [3]$$

Solving Eqs. [1], [2] and [3] yields

$$F_{AE} = F_{AD} = 1420.76 \text{ N} = 1.42 \text{ kN} \quad \text{Ans}$$

$$F_{AB} = 1319.28 \text{ N} = 1.32 \text{ kN} \quad \text{Ans}$$

3-54. Determine the force in each of the three cables needed to lift the tractor which has a mass of 8 Mg.

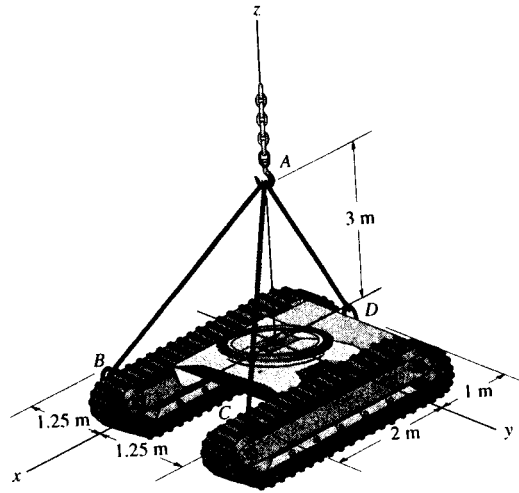

Cartesian Vector Notation :

$$F_{AB} = F_{AB} \left(\frac{2i - 1.25j - 3k}{\sqrt{2^2 + (-1.25)^2 + (-3)^2}} \right) = 0.5241F_{AB}i - 0.3276F_{AB}j - 0.7861F_{AB}k$$

$$F_{AC} = F_{AC} \left(\frac{2i + 1.25j - 3k}{\sqrt{2^2 + 1.25^2 + (-3)^2}} \right) = 0.5241F_{AC}i + 0.3276F_{AC}j - 0.7861F_{AC}k$$

$$F_{AD} = F_{AD} \left(\frac{-1i - 3k}{\sqrt{(-1)^2 + (-3)^2}} \right) = -0.3162F_{AD}i - 0.9487F_{AD}k$$

$$F = (78.48k) \text{ kN}$$

Equations of Equilibrium

$$\Sigma F = 0; \quad F_{AB} + F_{AC} + F_{AD} + F = 0$$

$$(0.5241F_{AB} + 0.5241F_{AC} - 0.3162F_{AD})i + (-0.3276F_{AB} + 0.3276F_{AC})j + (-0.7861F_{AB} - 0.7861F_{AC} - 0.9487F_{AD} + 78.48)k = 0$$

Equating i, j and k components, we have

$$0.5241F_{AB} + 0.5241F_{AC} - 0.3162F_{AD} = 0 \quad [1]$$

$$-0.3276F_{AB} + 0.3276F_{AC} = 0 \quad [2]$$

$$-0.7861F_{AB} - 0.7861F_{AC} - 0.9487F_{AD} + 78.48 = 0 \quad [3]$$

Solving Eqs. [1], [2] and [3] yields

$$F_{AB} = F_{AC} = 16.6 \text{ kN} \quad F_{AD} = 55.2 \text{ kN} \quad \text{Ans}$$

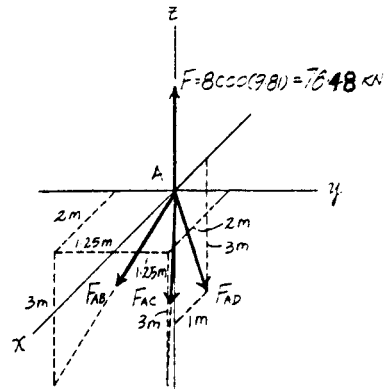

3-55. Determine the force acting along the axis of each of the three struts needed to support the 500-kg block.

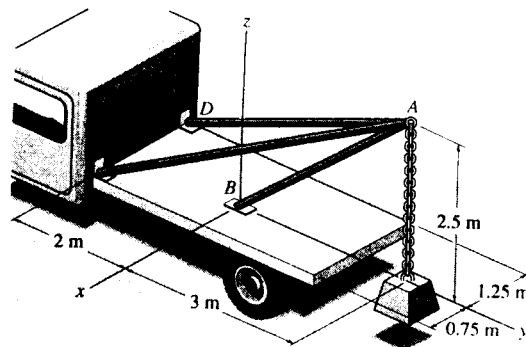

$$F_B = F_B \left(\frac{3 \mathbf{j} + 2.5 \mathbf{k}}{3.905} \right)$$

$$= 0.7682 F_B \mathbf{j} + 0.6402 F_B \mathbf{k}$$

$$F_C = F_C \left(\frac{0.75 \mathbf{i} - 5 \mathbf{j} - 2.5 \mathbf{k}}{5.640} \right)$$

$$= 0.1330 F_C \mathbf{i} - 0.8865 F_C \mathbf{j} - 0.4432 F_C \mathbf{k}$$

$$F_D = F_D \left(\frac{-1.25 \mathbf{i} - 5 \mathbf{j} - 2.5 \mathbf{k}}{5.728} \right)$$

$$= -0.2182 F_D \mathbf{i} - 0.8729 F_D \mathbf{j} - 0.4364 F_D \mathbf{k}$$

$$W = -500(9.81) \mathbf{k} = -4905 \mathbf{k}$$

$$\Sigma \mathbf{F} = 0; \quad F_B + F_C + F_D + W = 0$$

$$\Sigma F_x = 0; \quad 0.1330 F_C - 0.2182 F_D = 0$$

$$\Sigma F_y = 0; \quad 0.7682 F_B - 0.8865 F_C - 0.8729 F_D = 0$$

$$\Sigma F_z = 0; \quad 0.6402 F_B - 0.4432 F_C - 0.4364 F_D - 4905 = 0$$

$$F_B = 19.2 \text{ kN} \quad \text{Ans}$$

$$F_C = 10.4 \text{ kN} \quad \text{Ans}$$

$$F_D = 6.32 \text{ kN} \quad \text{Ans}$$

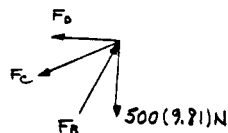

*3-56. The 50-kg pot is supported from A by the three cables. Determine the force acting in each cable for equilibrium. Take $d = 2.5$ m.

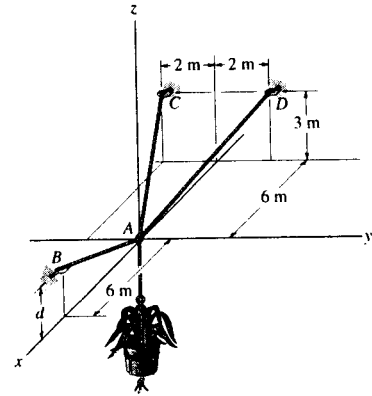

Cartesian Vector Notation :

$$\mathbf{F}_{AB} = F_{AB} \left(\frac{6\mathbf{i} + 2.5\mathbf{k}}{\sqrt{6^2 + 2.5^2}} \right) = \frac{12}{13}F_{AB}\mathbf{i} + \frac{5}{13}F_{AB}\mathbf{k}$$

$$\mathbf{F}_{AC} = F_{AC} \left(\frac{-6\mathbf{i} - 2\mathbf{j} + 3\mathbf{k}}{\sqrt{(-6)^2 + (-2)^2 + 3^2}} \right) = -\frac{6}{7}F_{AC}\mathbf{i} - \frac{2}{7}F_{AC}\mathbf{j} + \frac{3}{7}F_{AC}\mathbf{k}$$

$$\mathbf{F}_{AD} = F_{AD} \left(\frac{-6\mathbf{i} + 2\mathbf{j} + 3\mathbf{k}}{\sqrt{(-6)^2 + 2^2 + 3^2}} \right) = -\frac{6}{7}F_{AD}\mathbf{i} + \frac{2}{7}F_{AD}\mathbf{j} + \frac{3}{7}F_{AD}\mathbf{k}$$

$$\mathbf{F} = \{-490.5\mathbf{k}\} \text{ N}$$

Equations of Equilibrium :

$$\Sigma \mathbf{F} = \mathbf{0}; \quad \mathbf{F}_{AB} + \mathbf{F}_{AC} + \mathbf{F}_{AD} + \mathbf{F} = \mathbf{0}$$

$$\left(\frac{12}{13}F_{AB} - \frac{6}{7}F_{AC} - \frac{6}{7}F_{AD} \right)\mathbf{i} + \left(-\frac{2}{7}F_{AC} + \frac{2}{7}F_{AD} \right)\mathbf{j} + \left(\frac{5}{13}F_{AB} + \frac{3}{7}F_{AC} + \frac{3}{7}F_{AD} - 490.5 \right)\mathbf{k} = \mathbf{0}$$

Equating \mathbf{i} , \mathbf{j} and \mathbf{k} components, we have

$$\frac{12}{13}F_{AB} - \frac{6}{7}F_{AC} - \frac{6}{7}F_{AD} = 0 \quad [1]$$

$$-\frac{2}{7}F_{AC} + \frac{2}{7}F_{AD} = 0 \quad [2]$$

$$\frac{5}{13}F_{AB} + \frac{3}{7}F_{AC} + \frac{3}{7}F_{AD} - 490.5 = 0 \quad [3]$$

Solving Eqs. [1], [2] and [3] yields

$$F_{AC} = F_{AD} = 312 \text{ N}$$

$$F_{AB} = 580 \text{ N} \quad \text{Ans}$$

3-57. Determine the height d of cable AB so that the force in cables AD and AC is one-half as great as the force in cable AB . What is the force in each cable for this case? The flower pot has a mass of 50 kg.

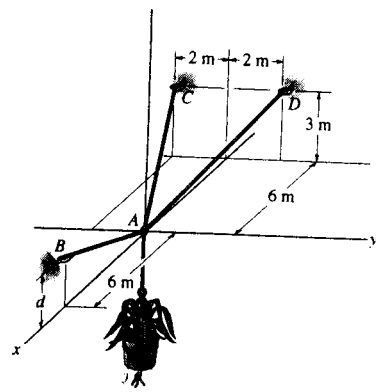

Cartesian Vector Notation :

$$\mathbf{F}_{AB} = (F_{AB})_x \mathbf{i} + (F_{AB})_z \mathbf{k}$$

$$\mathbf{F}_{AC} = \frac{F_{AB}}{2} \left(\frac{-6\mathbf{i} - 2\mathbf{j} + 3\mathbf{k}}{\sqrt{(-6)^2 + (-2)^2 + 3^2}} \right) = -\frac{3}{7}F_{AB}\mathbf{i} - \frac{1}{7}F_{AB}\mathbf{j} + \frac{3}{14}F_{AB}\mathbf{k}$$

$$\mathbf{F}_{AD} = \frac{F_{AB}}{2} \left(\frac{-6\mathbf{i} + 2\mathbf{j} + 3\mathbf{k}}{\sqrt{(-6)^2 + 2^2 + 3^2}} \right) = -\frac{3}{7}F_{AB}\mathbf{i} + \frac{1}{7}F_{AB}\mathbf{j} + \frac{3}{14}F_{AB}\mathbf{k}$$

$$\mathbf{F} = \{-490.5\mathbf{k}\} \text{ N}$$

Equations of Equilibrium :

$$\Sigma \mathbf{F} = 0; \quad \mathbf{F}_{AB} + \mathbf{F}_{AC} + \mathbf{F}_{AD} + \mathbf{F} = 0$$

$$\begin{aligned} & \left((F_{AB})_x - \frac{3}{7}F_{AB} - \frac{3}{7}F_{AB} \right) \mathbf{i} + \left(-\frac{1}{7}F_{AB} + \frac{1}{7}F_{AB} \right) \mathbf{j} \\ & + \left((F_{AB})_z + \frac{3}{14}F_{AB} + \frac{3}{14}F_{AB} - 490.5 \right) \mathbf{k} = 0 \end{aligned}$$

Equating i, j and k components, we have

$$(F_{AB})_x - \frac{3}{7}F_{AB} - \frac{3}{7}F_{AB} = 0 \quad (F_{AB})_x = \frac{6}{7}F_{AB} \quad [1]$$

$$-\frac{1}{7}F_{AB} + \frac{1}{7}F_{AB} = 0 \quad (\text{Satisfied!})$$

$$(F_{AB})_z + \frac{3}{14}F_{AB} + \frac{3}{14}F_{AB} - 490.5 = 0 \quad (F_{AB})_z = 490.5 - \frac{3}{7}F_{AB} \quad [2]$$

However, $F_{AB}^2 = (F_{AB})_x^2 + (F_{AB})_z^2$, then substitute Eqs. [1] and [2] into this expression yields

$$F_{AB}^2 = \left(\frac{6}{7}F_{AB} \right)^2 + \left(490.5 - \frac{3}{7}F_{AB} \right)^2$$

Solving for positive root, we have

$$F_{AB} = 519.79 \text{ N} = 520 \text{ N} \quad \text{Ans}$$

$$\text{Thus, } F_{AC} = F_{AD} = \frac{1}{2}(519.79) = 260 \text{ N} \quad \text{Ans}$$

Also,

$$(F_{AB})_x = \frac{6}{7}(519.79) = 445.53 \text{ N}$$

$$(F_{AB})_z = 490.5 - \frac{3}{7}(519.79) = 267.73 \text{ N}$$

$$\text{then, } \theta = \tan^{-1} \left[\frac{(F_{AB})_z}{(F_{AB})_x} \right] = \tan^{-1} \left(\frac{267.73}{445.53} \right) = 31.00^\circ$$

$$d = 6 \tan \theta = 6 \tan 31.00^\circ = 3.61 \text{ m} \quad \text{Ans}$$

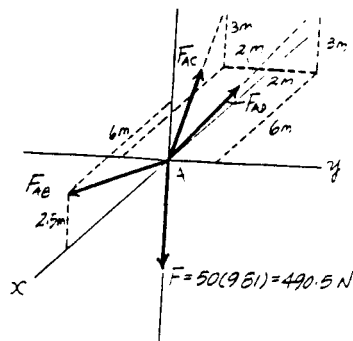

3-58. The 80-lb chandelier is supported by three wires as shown. Determine the force in each wire for equilibrium.

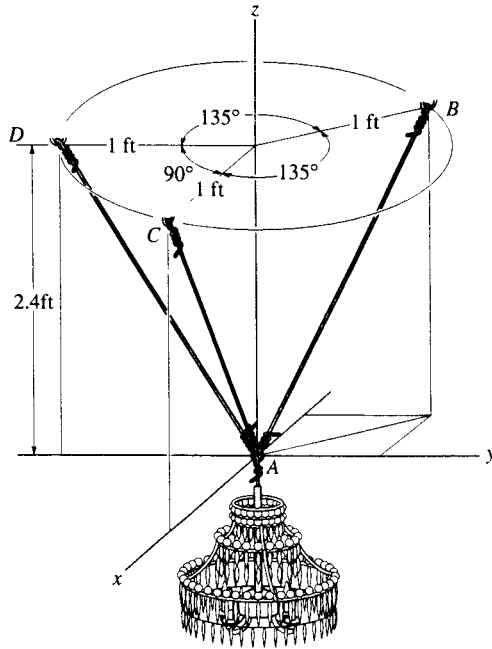

$$\Sigma F_x = 0; \quad \frac{1}{2.6}F_{AC} - \frac{1}{2.6}F_{AB} \cos 45^\circ = 0$$

$$\Sigma F_y = 0; \quad -\frac{1}{2.6}F_{AD} + \frac{1}{2.6}F_{AB} \sin 45^\circ = 0$$

$$\Sigma F_z = 0; \quad \frac{2.4}{2.6}F_{AC} + \frac{2.4}{2.6}F_{AD} + \frac{2.4}{2.6}F_{AB} - 80 = 0$$

Solving,

$$F_{AB} = 35.9 \text{ lb} \quad \text{Ans}$$

$$F_{AC} = F_{AD} = 25.4 \text{ lb} \quad \text{Ans}$$

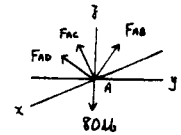

3-59. If each wire can sustain a maximum tension of 120 lb before it fails, determine the greatest weight of the chandelier the wires will support in the position shown.

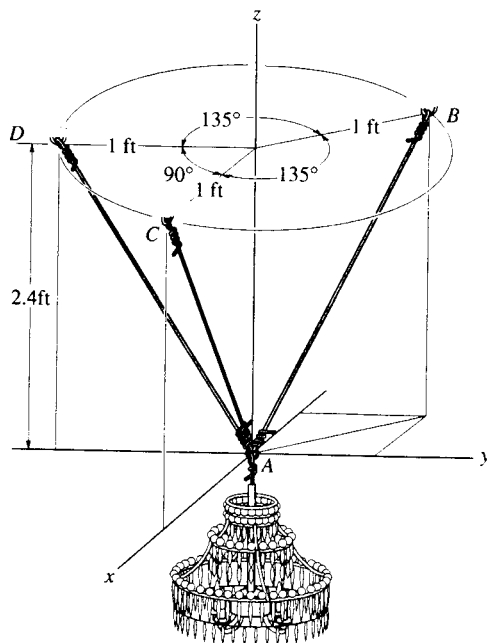

$$\Sigma F_x = 0; \quad \frac{1}{2.6}F_{AC} - \frac{1}{2.6}F_{AB} \cos 45^\circ = 0 \quad (1)$$

$$\Sigma F_y = 0; \quad -\frac{1}{2.6}F_{AD} + \frac{1}{2.6}F_{AB} \sin 45^\circ = 0 \quad (2)$$

$$\Sigma F_z = 0; \quad \frac{2.4}{2.6}F_{AC} + \frac{2.4}{2.6}F_{AD} + \frac{2.4}{2.6}F_{AB} - W = 0 \quad (3)$$

Assume $F_{AC} = 120$ lb. From Eq. (1)

$$\frac{1}{2.6}(120) - \frac{1}{2.6}F_{AB} \cos 45^\circ = 0$$

$$F_{AB} = 169.71 > 120 \text{ lb (N.G.)}$$

Assume $F_{AB} = 120$ lb. From Eqs. (1) and (2)

$$\frac{1}{2.6}F_{AC} - \frac{1}{2.6}(120)(\cos 45^\circ) = 0$$

$$F_{AC} = 84.853 \text{ lb} < 120 \text{ lb (O.K.)}$$

$$-\frac{1}{2.6}F_{AD} + \frac{1}{2.6}(120) \sin 45^\circ = 0$$

$$F_{AD} = 84.853 \text{ lb} < 120 \text{ lb (O.K.)}$$

Thus,

$$W = \frac{2.4}{2.6}(F_{AC} + F_{AD} + F_{AB}) = 267.42 = 267 \text{ lb} \quad \text{Ans}$$

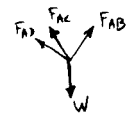

*3-60. Three cables are used to support a 900-lb ring. Determine the tension in each cable for equilibrium.

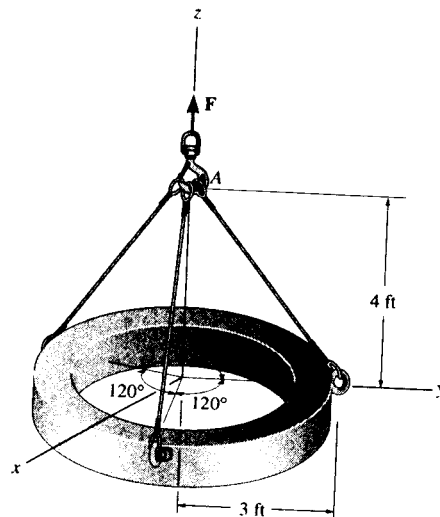

Cartesian Vector Notation :

$$\mathbf{F}_{AB} = F_{AB} \left(\frac{3\mathbf{j} - 4\mathbf{k}}{\sqrt{3^2 + (-4)^2}} \right) = 0.6F_{AB}\mathbf{j} - 0.8F_{AB}\mathbf{k}$$

$$\begin{aligned} \mathbf{F}_{AC} &= F_{AC} \left(\frac{3\cos 30^\circ\mathbf{i} - 3\sin 30^\circ\mathbf{j} - 4\mathbf{k}}{\sqrt{(3\cos 30^\circ)^2 + (-3\sin 30^\circ)^2 + (-4)^2}} \right) \\ &= 0.5196F_{AC}\mathbf{i} - 0.3F_{AC}\mathbf{j} - 0.8F_{AC}\mathbf{k} \end{aligned}$$

$$\begin{aligned} \mathbf{F}_{AD} &= F_{AD} \left(\frac{-3\cos 30^\circ\mathbf{i} - 3\sin 30^\circ\mathbf{j} - 4\mathbf{k}}{\sqrt{(-3\cos 30^\circ)^2 + (-3\sin 30^\circ)^2 + (-4)^2}} \right) \\ &= -0.5196F_{AD}\mathbf{i} - 0.3F_{AD}\mathbf{j} - 0.8F_{AD}\mathbf{k} \end{aligned}$$

$$\mathbf{F} = (900\mathbf{k}) \text{ lb}$$

Equations of Equilibrium :

$$\Sigma \mathbf{F} = 0; \quad \mathbf{F}_{AB} + \mathbf{F}_{AC} + \mathbf{F}_{AD} + \mathbf{F} = 0$$

$$\begin{aligned} (0.5196F_{AC} - 0.5196F_{AD})\mathbf{i} + (0.6F_{AB} - 0.3F_{AC} - 0.3F_{AD})\mathbf{j} \\ + (-0.8F_{AB} - 0.8F_{AC} - 0.8F_{AD} + 900)\mathbf{k} = 0 \end{aligned}$$

Equating i, j and k components, we have

$$0.5196F_{AC} - 0.5196F_{AD} = 0 \quad [1]$$

$$0.6F_{AB} - 0.3F_{AC} - 0.3F_{AD} = 0 \quad [2]$$

$$-0.8F_{AB} - 0.8F_{AC} - 0.8F_{AD} + 900 = 0 \quad [3]$$

Solving Eqs. [1], [2] and [3] yields

$$F_{AB} = F_{AC} = F_{AD} = 375 \text{ lb}$$

Ans

This problem also can be easily solved if one realizes that due to symmetry all cables are subjected to a same tensile force, that is $F_{AB} = F_{AC} = F_{AD} = F$. Summing forces along z axis yields

$$\Sigma F_z = 0; \quad 900 - 3F\left(\frac{4}{5}\right) = 0 \quad F = 375 \text{ lb}$$

3-61. The 800-lb cylinder is supported by three chains as shown. Determine the force in each chain for equilibrium. Take $d = 1$ ft.

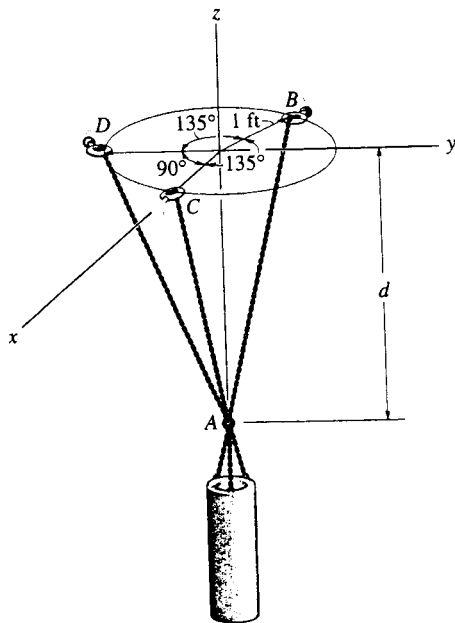

$$F_{AD} = F_{AD} \left(\frac{-1\mathbf{j} + 1\mathbf{k}}{\sqrt{(-1)^2 + 1^2}} \right) = -0.7071F_{AD}\mathbf{j} + 0.7071F_{AD}\mathbf{k}$$

$$F_{AC} = F_{AC} \left(\frac{1\mathbf{i} + 1\mathbf{k}}{\sqrt{1^2 + 1^2}} \right) = 0.7071F_{AC}\mathbf{i} + 0.7071F_{AC}\mathbf{k}$$

$$F_{AB} = F_{AB} \left(\frac{-0.7071\mathbf{i} + 0.7071\mathbf{j} + 1\mathbf{k}}{\sqrt{(-0.7071)^2 + 0.7071^2 + 1^2}} \right)$$

$$= -0.5F_{AB}\mathbf{i} + 0.5F_{AB}\mathbf{j} + 0.7071F_{AB}\mathbf{k}$$

$$\mathbf{F} = (-800\mathbf{k}) \text{ lb}$$



$$\Sigma \mathbf{F} = \mathbf{0}; \quad F_{AD} + F_{AC} + F_{AB} + \mathbf{F} = \mathbf{0}$$

$$(-0.7071F_{AD}\mathbf{j} + 0.7071F_{AD}\mathbf{k}) + (0.7071F_{AC}\mathbf{i} + 0.7071F_{AC}\mathbf{k})$$

$$+ (-0.5F_{AB}\mathbf{i} + 0.5F_{AB}\mathbf{j} + 0.7071F_{AB}\mathbf{k}) + (-800\mathbf{k}) = \mathbf{0}$$

$$(0.7071F_{AC} - 0.5F_{AB})\mathbf{i} + (-0.7071F_{AD} + 0.5F_{AB})\mathbf{j}$$

$$+ (0.7071F_{AD} + 0.7071F_{AC} + 0.7071F_{AB} - 800)\mathbf{k} = \mathbf{0}$$

$$\Sigma F_x = 0; \quad 0.7071F_{AC} - 0.5F_{AB} = 0$$

$$\Sigma F_y = 0; \quad -0.7071F_{AD} + 0.5F_{AB} = 0$$

$$\Sigma F_z = 0; \quad 0.7071F_{AD} + 0.7071F_{AC} + 0.7071F_{AB} - 800 = 0$$

Solving Eqs. [1], [2] and [3] yields :

$$F_{AB} = 469 \text{ lb} \quad F_{AC} = F_{AD} = 331 \text{ lb} \quad \text{Ans}$$

3-62. A small peg P rests on a spring that is contained inside the smooth pipe. When the spring is compressed so that $s = 0.15$ m, the spring exerts an upward force of 60 N on the peg. Determine the point of attachment $A(x, y, 0)$ of cord PA so that the tension in cords PB and PC equals 30 N and 50 N, respectively.

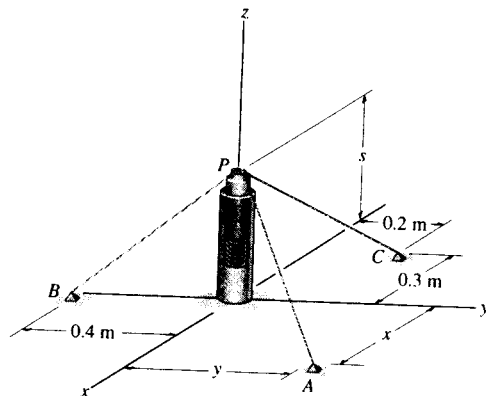

Cartesian Vector Notation :

$$\mathbf{F}_{PA} = (F_{PA})_x \mathbf{i} + (F_{PA})_y \mathbf{j} + (F_{PA})_z \mathbf{k}$$

$$\mathbf{F}_{PB} = 30 \left(\frac{-0.4\mathbf{j} - 0.15\mathbf{k}}{\sqrt{(-0.4)^2 + (-0.15)^2}} \right) = \{-28.09\mathbf{j} - 10.53\mathbf{k}\} \text{ N}$$

$$\mathbf{F}_{PC} = 50 \left(\frac{-0.3\mathbf{i} + 0.2\mathbf{j} - 0.15\mathbf{k}}{\sqrt{(-0.3)^2 + 0.2^2 + (-0.15)^2}} \right) = \{-38.4\mathbf{i} + 25.6\mathbf{j} - 19.2\mathbf{k}\} \text{ N}$$

$$\mathbf{F} = \{60\mathbf{k}\} \text{ N}$$

Equations of Equilibrium :

$$\Sigma \mathbf{F} = \mathbf{0}; \quad \mathbf{F}_{PA} + \mathbf{F}_{PB} + \mathbf{F}_{PC} + \mathbf{F} = \mathbf{0}$$

$$\begin{aligned} [(F_{PA})_x - 38.4]\mathbf{i} + [(F_{PA})_y - 28.09 + 25.6]\mathbf{j} \\ + [(F_{PA})_z - 10.53 - 19.2 + 60]\mathbf{k} = \mathbf{0} \end{aligned}$$

Equating \mathbf{i} , \mathbf{j} and \mathbf{k} components, we have

$$\begin{aligned} (F_{PA})_x - 38.4 &= 0 & (F_{PA})_x &= 38.4 \text{ N} \\ (F_{PA})_y - 28.09 + 25.6 &= 0 & (F_{PA})_y &= 2.48 \text{ N} \\ (F_{PA})_z - 10.53 - 19.2 + 60 &= 0 & (F_{PA})_z &= -30.26 \text{ N} \end{aligned}$$

The magnitude of \mathbf{F}_{PA} is

$$\begin{aligned} F_{PA} &= \sqrt{(F_{PA})_x^2 + (F_{PA})_y^2 + (F_{PA})_z^2} \\ &= \sqrt{38.41^2 + 2.48^2 + (-30.26)^2} = 48.96 \text{ N} \end{aligned}$$

The coordinate direction angles are

$$\begin{aligned} \alpha &= \cos^{-1} \left[\frac{(F_{PA})_x}{F_{PA}} \right] = \cos^{-1} \left(\frac{38.41}{48.96} \right) = 38.32^\circ \\ \beta &= \cos^{-1} \left[\frac{(F_{PA})_y}{F_{PA}} \right] = \cos^{-1} \left(\frac{2.48}{48.96} \right) = 87.09^\circ \\ \gamma &= \cos^{-1} \left[\frac{(F_{PA})_z}{F_{PA}} \right] = \cos^{-1} \left(\frac{-30.26}{48.96} \right) = 128.17^\circ \end{aligned}$$

The wire PA has a length of

$$PA = \frac{(PA)_z}{\cos \gamma} = \frac{-0.15}{\cos 128.17^\circ} = 0.2427 \text{ m}$$

Thus,

$$\begin{aligned} x &= PA \cos \alpha = 0.2427 \cos 38.32^\circ = 0.190 \text{ m} \\ y &= PA \cos \beta = 0.2427 \cos 87.09^\circ = 0.0123 \text{ m} \end{aligned}$$

Ans
Ans

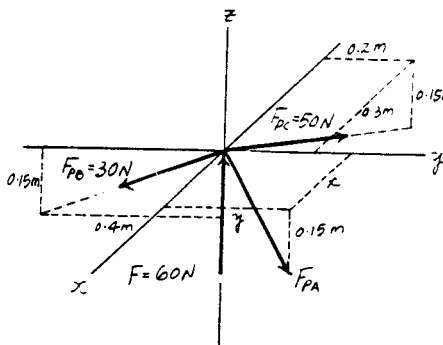

3-63. Determine the force in each cable support the 3500-lb platform. Set $d = 4$ ft.

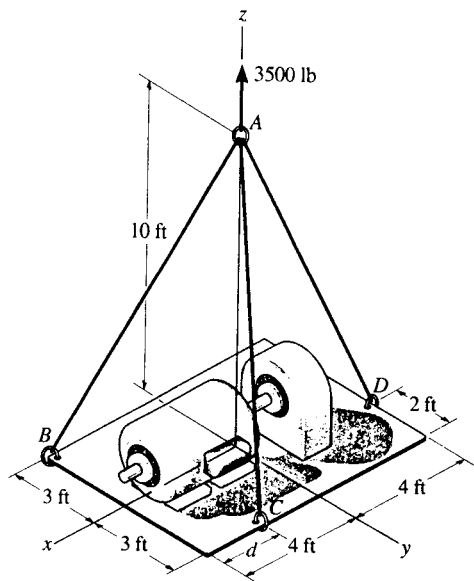

$$\mathbf{F}_{AD} = F_{AD} \left\{ \frac{-4}{\sqrt{117}} \mathbf{i} + \frac{1}{\sqrt{117}} \mathbf{j} - \frac{10}{\sqrt{117}} \mathbf{k} \right\}$$

$$= \{-0.3698F_{AD} \mathbf{i} + 0.09245F_{AD} \mathbf{j} - 0.9245F_{AD} \mathbf{k}\} \text{ lb}$$

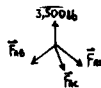

$$\mathbf{F}_{AC} = F_{AC} \left\{ \frac{3}{\sqrt{109}} \mathbf{j} - \frac{10}{\sqrt{109}} \mathbf{k} \right\}$$

$$= \{0.2873F_{AC} \mathbf{j} - 0.9578F_{AC} \mathbf{k}\} \text{ lb}$$

$$\mathbf{F}_{AB} = F_{AB} \left\{ \frac{4}{\sqrt{125}} \mathbf{i} - \frac{3}{\sqrt{125}} \mathbf{j} - \frac{10}{\sqrt{125}} \mathbf{k} \right\}$$

$$= \{0.3578F_{AB} \mathbf{i} - 0.2683F_{AB} \mathbf{j} - 0.8944F_{AB} \mathbf{k}\} \text{ lb}$$

$$\Sigma F_x = 0; \quad -0.3698F_{AD} + 0.3578F_{AB} = 0$$

$$\Sigma F_y = 0; \quad 0.09245F_{AD} + 0.2873F_{AC} - 0.2683F_{AB} = 0$$

$$\Sigma F_z = 0; \quad -0.9245F_{AD} - 0.9578F_{AC} - 0.8944F_{AB} + 3500 = 0$$

Solving,

$$F_{AD} = 1.42 \text{ kip} \quad \text{Ans}$$

$$F_{AC} = 0.914 \text{ kip} \quad \text{Ans}$$

$$F_{AB} = 1.47 \text{ kip} \quad \text{Ans}$$

3-64. The 80-lb ball is suspended from the horizontal ring using three springs each having an unstretched length of 1.5 ft and stiffness of 50 lb/ft. Determine the vertical distance h from the ring to point A for equilibrium.

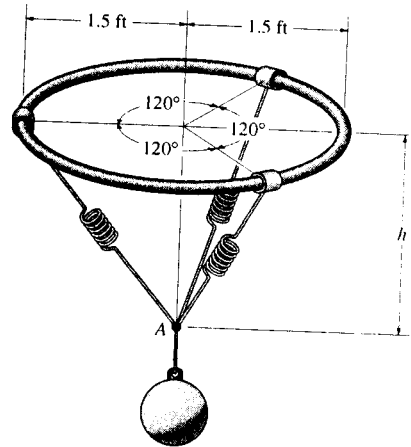

Equation of Equilibrium: This problem also can be easily solved if one realizes that due to symmetry all springs are subjected to a same tensile force of F_{sp} . Summing forces along z axis yields

$$\Sigma F_z = 0; \quad 3F_{sp} \cos \gamma - 80 = 0 \quad [1]$$

Spring Force: Applying Eq. 3-2, we have

$$F_{sp} = ks = k(l - l_0) = 50 \left(\frac{1.5}{\sin \gamma} - 1.5 \right) = \frac{75}{\sin \gamma} - 75 \quad [2]$$

Substituting Eq. [2] into [1] yields

$$3 \left(\frac{75}{\sin \gamma} - 75 \right) \cos \gamma - 80 = 0$$

$$\tan \gamma = \frac{45}{16} (1 - \sin \gamma)$$

Solving by trial and error, we have

$$\gamma = 42.4425^\circ$$

Geometry:

$$h = \frac{1.5}{\tan \gamma} = \frac{1.5}{\tan 42.4425^\circ} = 1.64 \text{ ft} \quad \text{Ans}$$

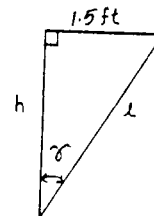
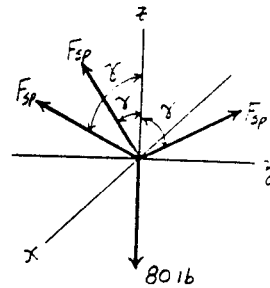

3-65. Determine the tension developed in cables OD and OB and the strut OC , required to support the 50-kg crate. The spring OA has an unstretched length of 0.8 m and a stiffness $k_{OA} = 1.2 \text{ kN/m}$. The force in the strut acts along the axis of the strut.

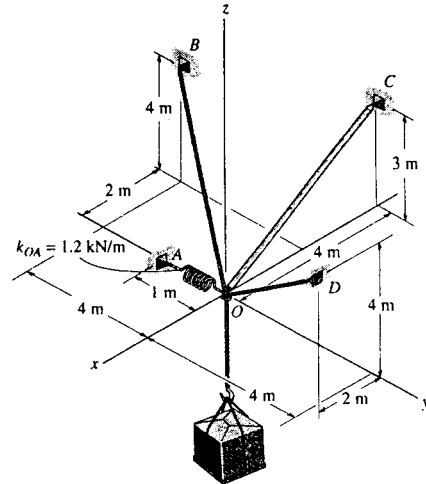

Free Body Diagram : The spring stretches $s = l - l_0 = 1 - 0.8 = 0.2 \text{ m}$. Hence, the spring force is $F_{sp} = ks = 1.2(0.2) = 0.24 \text{ kN} = 240 \text{ N}$.

Cartesian Vector Notation :

$$\mathbf{F}_{OB} = F_{OB} \left(\frac{-2\mathbf{i} - 4\mathbf{j} + 4\mathbf{k}}{\sqrt{(-2)^2 + (-4)^2 + 4^2}} \right) = -\frac{1}{3}F_{OB}\mathbf{i} - \frac{2}{3}F_{OB}\mathbf{j} + \frac{2}{3}F_{OB}\mathbf{k}$$

$$\mathbf{F}_{OC} = F_{OC} \left(\frac{-4\mathbf{i} + 3\mathbf{k}}{\sqrt{(-4)^2 + 3^2}} \right) = -\frac{4}{5}F_{OC}\mathbf{i} + \frac{3}{5}F_{OC}\mathbf{k}$$

$$\mathbf{F}_{OD} = F_{OD} \left(\frac{2\mathbf{i} + 4\mathbf{j} + 4\mathbf{k}}{\sqrt{2^2 + 4^2 + 4^2}} \right) = \frac{1}{3}F_{OD}\mathbf{i} + \frac{2}{3}F_{OD}\mathbf{j} + \frac{2}{3}F_{OD}\mathbf{k}$$

$$\mathbf{F}_{sp} = \{-240\mathbf{j}\} \text{ N} \quad \mathbf{F} = \{-490.5\mathbf{k}\} \text{ N}$$

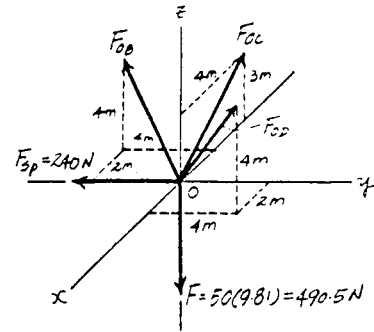

Equations of Equilibrium :

$$\Sigma \mathbf{F} = 0; \quad \mathbf{F}_{OB} + \mathbf{F}_{OC} + \mathbf{F}_{OD} + \mathbf{F}_{sp} + \mathbf{F} = 0$$

$$\left(-\frac{1}{3}F_{OB} - \frac{4}{5}F_{OC} + \frac{1}{3}F_{OD} \right) \mathbf{i} + \left(-\frac{2}{3}F_{OB} + \frac{2}{3}F_{OD} - 240 \right) \mathbf{j} + \left(\frac{2}{3}F_{OB} + \frac{3}{5}F_{OC} + \frac{2}{3}F_{OD} - 490.5 \right) \mathbf{k} = 0$$

Equating i, j and k components, we have

$$-\frac{1}{3}F_{OB} - \frac{4}{5}F_{OC} + \frac{1}{3}F_{OD} = 0 \quad [1]$$

$$-\frac{2}{3}F_{OB} + \frac{2}{3}F_{OD} - 240 = 0 \quad [2]$$

$$\frac{2}{3}F_{OB} + \frac{3}{5}F_{OC} + \frac{2}{3}F_{OD} - 490.5 = 0 \quad [3]$$

Solving Eqs. [1], [2] and [3] yields

$$F_{OB} = 120 \text{ N} \quad F_{OC} = 150 \text{ N} \quad F_{OD} = 480 \text{ N} \quad \text{Ans}$$

3-66. The pipe is held in place by the vice. If the bolt exerts a force of 50 lb on the pipe in the direction shown, determine the forces F_A and F_B that the smooth contacts at A and B exert on the pipe.

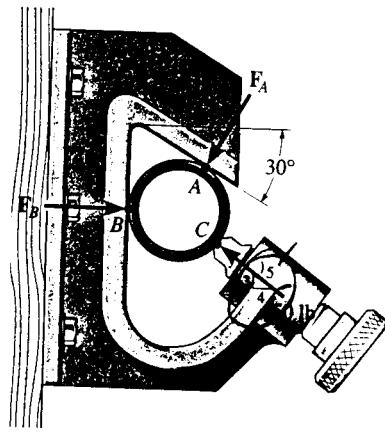

$$\begin{aligned} \rightarrow \Sigma F_x = 0; & \quad F_B - F_A \cos 60^\circ - 50\left(\frac{4}{5}\right) = 0 \\ + \uparrow \Sigma F_y = 0; & \quad -F_A \sin 60^\circ + 50\left(\frac{3}{5}\right) = 0 \\ & \quad F_A = 34.6 \text{ lb} \quad \text{Ans} \\ & \quad F_B = 57.3 \text{ lb} \quad \text{Ans} \end{aligned}$$

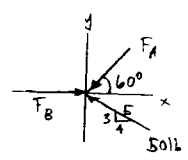

3-67. When y is zero, the springs sustain a force of 60 lb. Determine the magnitude of the applied vertical forces F and $-F$ required to pull point A away from point B a distance of $y = 2$ ft. The ends of cords CAD and CBD are attached to rings at C and D.

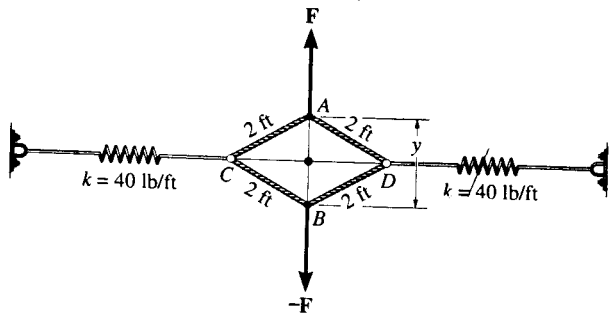

Initial spring stretch:

$$s_1 = \frac{60}{40} = 1.5 \text{ ft}$$

$$\begin{aligned} + \uparrow \Sigma F_y = 0; & \quad F - 2\left(\frac{1}{2}T\right) = 0; \quad F = T \\ \rightarrow \Sigma F_x = 0; & \quad -F_x + 2\left(\frac{\sqrt{3}}{2}\right)F = 0 \\ & \quad F_x = 1.732F \end{aligned}$$

Final stretch is $1.5 + 0.268 = 1.768 \text{ ft}$

$$\begin{aligned} 40(1.768) &= 1.732F \\ F &= 40.8 \text{ lb} \quad \text{Ans} \end{aligned}$$

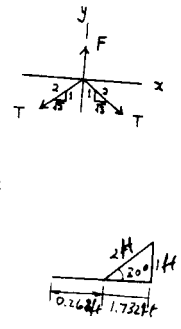

*3-68. When y is zero, the springs are each stretched 1.5 ft. Determine the distance y if a force of $F = 60$ lb is applied to points A and B as shown. The ends of cords CAD and CBD are attached to rings at C and D.

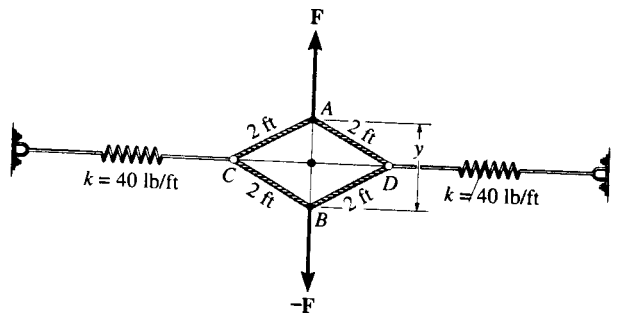

$$\begin{aligned} + \uparrow \Sigma F_y = 0; & \quad 2T \sin \theta = 60 \\ & \quad T \sin \theta = 30 \\ \rightarrow \Sigma F_x = 0; & \quad 2T \cos \theta = F \\ & \quad F \tan \theta = 60 \quad (1) \\ & \quad F = kx \\ & \quad F = 40(1.5 + 2 - 2 \cos \theta) \end{aligned}$$

Substitute F in Eq. 1

$$\begin{aligned} 40(1.5 + 2 - 2 \cos \theta) \tan \theta &= 60 \\ (3.5 - 2 \cos \theta) \tan \theta &= 1.5 \\ 3.5 \tan \theta - 2 \sin \theta &= 1.5 \\ 1.75 \tan \theta - \sin \theta &= 0.75 \end{aligned}$$

By trial and error:

$$\begin{aligned} \theta &= 37.9^\circ \\ \frac{y}{2} &= 2 \sin 37.9^\circ \\ y &= 2.46 \text{ ft} \quad \text{Ans} \end{aligned}$$

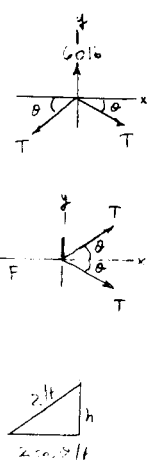

3-69. Romeo tries to reach Juliet by climbing with constant velocity up a rope which is knotted at point A. Any of the three segments of the rope can sustain a maximum force of 2 kN before it breaks. Determine if Romeo, who has a mass of 65 kg, can climb the rope, and if so, can he along with his Juliet, who has a mass of 60 kg, climb down with constant velocity?

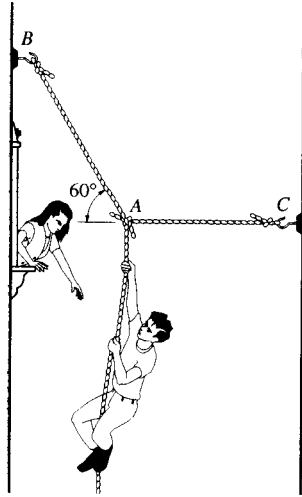

$$\begin{aligned}
 +\uparrow \Sigma F_y = 0; & \quad T_{AB} \sin 60^\circ - 65(9.81) = 0 \\
 & \quad T_{AB} = 736.29 \text{ N} < 2000 \text{ N} \\
 \rightarrow \Sigma F_x = 0; & \quad T_{AC} - 736.29 \cos 60^\circ = 0 \\
 & \quad T_{AC} = 368.15 \text{ N} < 2000 \text{ N}
 \end{aligned}$$

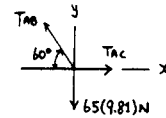

Yes, Romeo can climb up the rope. **Ans**

$$\begin{aligned}
 +\uparrow \Sigma F_y = 0; & \quad T_{AB} \sin 60^\circ - 125(9.81) = 0 \\
 & \quad T_{AB} = 1415.95 \text{ N} < 2000 \text{ N} \\
 \rightarrow \Sigma F_x = 0; & \quad T_{AC} - 1415.95 \cos 60^\circ = 0 \\
 & \quad T_{AC} = 708 \text{ N} < 2000 \text{ N}
 \end{aligned}$$

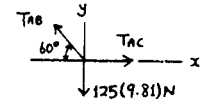

Yes, Romeo and Juliet can climb down **Ans**

3-70. Determine the magnitudes of forces F_1 , F_2 , and F_3 necessary to hold the force $F = \{-9\mathbf{i} - 8\mathbf{j} - 5\mathbf{k}\}$ kN in equilibrium.

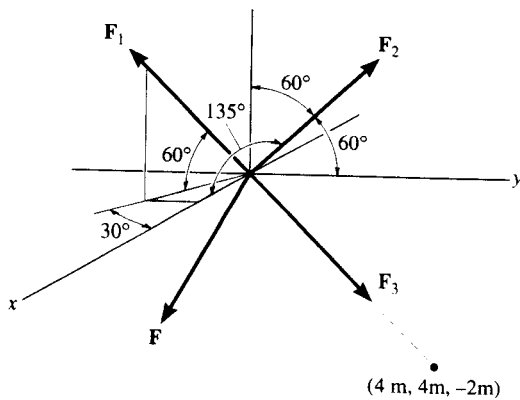

$$\Sigma F_x = 0; \quad F_1 \cos 60^\circ \cos 30^\circ + F_2 \cos 135^\circ + \frac{4}{6}F_3 - 9 = 0$$

$$\Sigma F_y = 0; \quad -F_1 \cos 60^\circ \sin 30^\circ + F_2 \cos 60^\circ + \frac{4}{6}F_3 - 8 = 0$$

$$\Sigma F_z = 0; \quad F_1 \sin 60^\circ + F_2 \cos 60^\circ - \frac{2}{6}F_3 - 5 = 0$$

$$0.433F_1 - 0.707F_2 + 0.667F_3 = 9$$

$$-0.250F_1 + 0.500F_2 + 0.667F_3 = 8$$

$$0.866F_1 + 0.500F_2 - 0.333F_3 = 5$$

Solving,

$$F_1 = 8.26 \text{ kN} \quad \text{Ans}$$

$$F_2 = 3.84 \text{ kN} \quad \text{Ans}$$

$$F_3 = 12.2 \text{ kN} \quad \text{Ans}$$

3-71. The man attempts to pull the log at C by using the three ropes. Determine the direction θ in which he should pull on his rope with a force of 80 lb, so that he exerts a maximum force on the log. What is the force on the log for this case? Also, determine the direction in which he should pull in order to maximize the force in the rope attached to B . What is this maximum force?

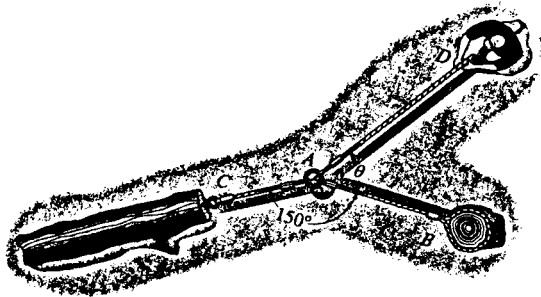

$$\rightarrow \Sigma F_x = 0; \quad F_{AB} + 80 \cos \theta - F_{AC} \sin 60^\circ = 0$$

$$+ \uparrow \Sigma F_y = 0; \quad 80 \sin \theta - F_{AC} \cos 60^\circ = 0$$

$$F_{AC} = 160 \sin \theta$$

$$\frac{dF_{AC}}{d\theta} = 160 \cos \theta = 0$$

$$\theta = 90^\circ \quad \text{Ans}$$

$$F_{AC} = 160 \text{ lb} \quad \text{Ans}$$

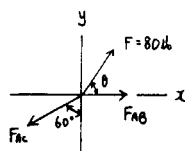

$$F_{AC} \sin 60^\circ = F_{AB} + 80 \cos \theta$$

$$80 \sin \theta \sin 60^\circ = (F_{AB} + 80 \cos \theta) \cos 60^\circ$$

$$F_{AB} = 138.6 \sin \theta - 80 \cos \theta$$

$$\frac{dF_{AB}}{d\theta} = 138.6 \cos \theta + 80 \sin \theta = 0$$

$$\theta = \tan^{-1} \left[\frac{138.6}{-80} \right] = 120^\circ \quad \text{Ans}$$

$$F_{AB} = 138.6 \sin 120^\circ - 80 \cos 120^\circ = 160 \text{ lb} \quad \text{Ans}$$

■3-72. The ring of negligible size is subjected to a vertical force of 200 lb. Determine the required length l of cord AC such that the tension acting in AC is 160 lb. Also, what is the force acting in cord AB ? *Hint:* Use the equilibrium condition to determine the required angle θ for attachment, then determine l using trigonometry applied to $\triangle ABC$.

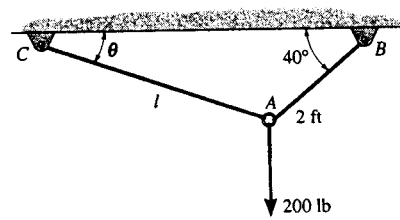

Equations of Equilibrium :

$$\rightarrow \Sigma F_x = 0; \quad F_{AB} \cos 40^\circ - 160 \cos \theta = 0 \quad [1]$$

$$+ \uparrow \Sigma F_y = 0; \quad F_{AB} \sin 40^\circ + 160 \sin \theta - 200 = 0 \quad [2]$$

Solving Eqs. [1] and [2] yields

$$\theta = 33.25^\circ \quad \text{Ans}$$

$$F_{AB} = 175 \text{ lb}$$

Geometry : Applying law of sines, we have

$$\frac{l}{\sin 40^\circ} = \frac{2}{\sin 33.25^\circ}$$

$$l = 2.34 \text{ ft} \quad \text{Ans}$$

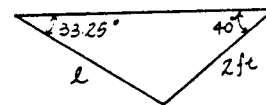
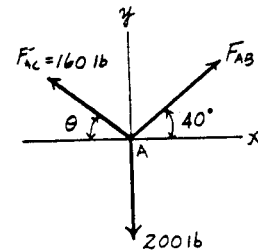

3-73. Determine the maximum weight of the engine that can be supported without exceeding a tension of 450 lb in chain AB and 480 lb in chain AC .

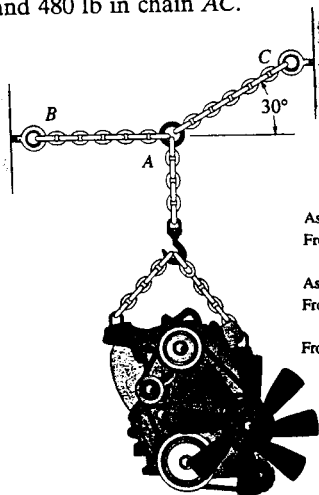

$$\rightarrow \Sigma F_x = 0; \quad F_{AC} \cos 30^\circ - F_{AB} = 0 \quad [1]$$

$$+ \uparrow \Sigma F_y = 0; \quad F_{AC} \sin 30^\circ - W = 0 \quad [2]$$

Assuming cable AB reaches the maximum tension $F_{AB} = 450 \text{ lb}$.

From Eq. [1] $F_{AC} \cos 30^\circ - 450 = 0$ $F_{AC} = 519.6 \text{ lb} > 480 \text{ lb (N.G!)}$

Assuming cable AC reaches the maximum tension $F_{AC} = 480 \text{ lb}$.

From Eq. [1] $480 \cos 30^\circ - F_{AB} = 0$ $F_{AB} = 415.7 \text{ lb} < 450 \text{ lb (O.K!)}$

From Eq. [2] $480 \sin 30^\circ - W = 0$ $W = 240 \text{ lb}$ **Ans**

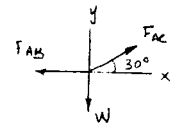

3-72. The ring of negligible size is subjected to a vertical force of 200 lb. Determine the required length l of cord AC such that the tension acting in AC is 160 lb. Also, what is the force acting in cord AB ? *Hint:* Use the equilibrium condition to determine the required angle θ for attachment, then determine l using trigonometry applied to $\triangle ABC$.

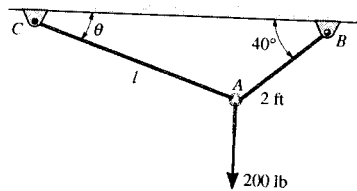

Equations of Equilibrium:

$$\rightarrow \Sigma F_x = 0; \quad F_{AB} \cos 40^\circ - 160 \cos \theta = 0 \quad [1]$$

$$+ \uparrow \Sigma F_y = 0; \quad F_{AB} \sin 40^\circ + 160 \sin \theta - 200 = 0 \quad [2]$$

Solving Eqs. [1] and [2] yields

$$\begin{aligned} \theta = 33.25^\circ & \quad \text{or} \quad \theta = 66.75^\circ \\ F_{AB} = 175 \text{ lb} & \quad \text{or} \quad F_{AB} = 82.4 \text{ lb} \end{aligned} \quad \text{Ans}$$

Geometry: Applying law of sines, we have

$$\frac{l}{\sin 40^\circ} = \frac{2}{\sin 33.25^\circ} \quad \text{or} \quad \frac{l}{\sin 40^\circ} = \frac{2}{\sin 66.75^\circ}$$

$$l = 2.34 \text{ ft} \quad \text{or} \quad l = 1.40 \text{ ft} \quad \text{Ans}$$

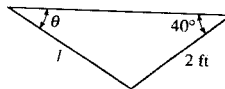
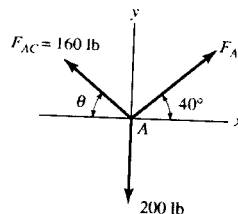

3-73. Determine the maximum weight of the engine that can be supported without exceeding a tension of 450 lb in chain AB and 480 lb in chain AC .

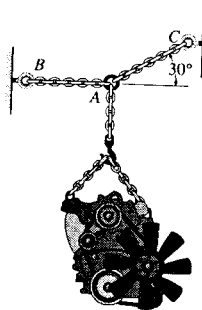

$$\rightarrow \Sigma F_x = 0; \quad F_{AC} \cos 30^\circ - F_{AB} = 0 \quad [1]$$

$$+ \uparrow \Sigma F_y = 0; \quad F_{AC} \sin 30^\circ - W = 0 \quad [2]$$

Assuming cable AB reaches the maximum tension $F_{AB} = 450$ lb.
From Eq. [1] $F_{AC} \cos 30^\circ - 450 = 0$ $F_{AC} = 519.6 \text{ lb} > 480 \text{ lb}$ (N.G!)

Assuming cable AC reaches the maximum tension $F_{AC} = 480$ lb.
From Eq. [1] $480 \cos 30^\circ - F_{AB} = 0$ $F_{AB} = 415.7 \text{ lb} < 450 \text{ lb}$ (O.K!)

From Eq. [2] $480 \sin 30^\circ - W = 0$ $W = 240 \text{ lb}$ **Ans**

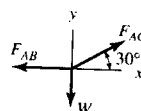

*3-74. Determine the force in each cable needed to support the 500-lb load.

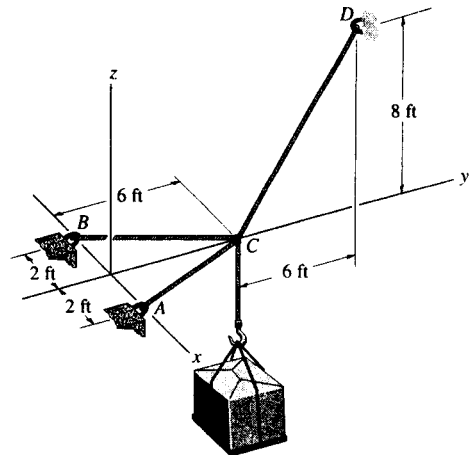

Equation of Equilibrium :

$$\Sigma F_z = 0; \quad F_{CD} \left(\frac{4}{5} \right) - 500 = 0 \quad F_{CD} = 625 \text{ lb} \quad \text{Ans}$$

Using the results $F_{CD} = 625 \text{ lb}$ and then summing forces along x and y axes we have

$$\Sigma F_x = 0; \quad F_{CA} \left(\frac{2}{\sqrt{40}} \right) - F_{CB} \left(\frac{2}{\sqrt{40}} \right) = 0 \quad F_{CA} = F_{CB} = F$$

$$\Sigma F_y = 0; \quad 2F \left(\frac{6}{\sqrt{40}} \right) - 625 \left(\frac{3}{5} \right) = 0$$

$$F_{CA} = F_{CB} = F = 198 \text{ lb} \quad \text{Ans}$$

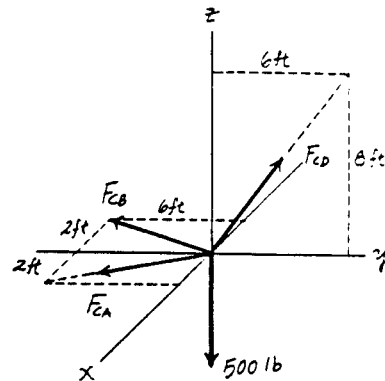

3-75. The joint of a space frame is subjected to four member forces. Member OA lies in the $x - y$ plane and member OB lies in the $y - z$ plane. Determine the forces acting in each of the members required for equilibrium of the joint.

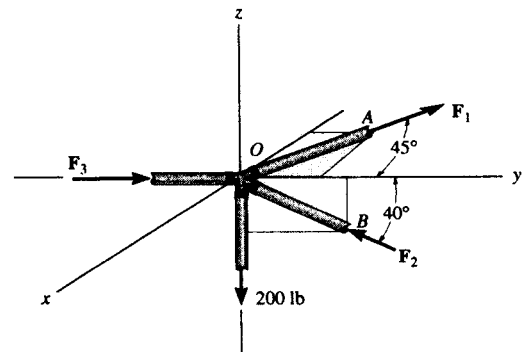

Equation of Equilibrium :

$$\Sigma F_x = 0; \quad F_1 \sin 45^\circ = 0 \quad F_1 = 0 \quad \text{Ans}$$

$$\Sigma F_z = 0; \quad F_2 \sin 40^\circ - 200 = 0 \quad F_2 = 311.14 \text{ lb} = 311 \text{ lb} \quad \text{Ans}$$

Using the results $F_1 = 0$ and $F_2 = 311.14 \text{ lb}$ and then summing forces along the y axis, we have

$$\Sigma F_y = 0; \quad F_3 - 311.14 \cos 40^\circ = 0 \quad F_3 = 238 \text{ lb} \quad \text{Ans}$$

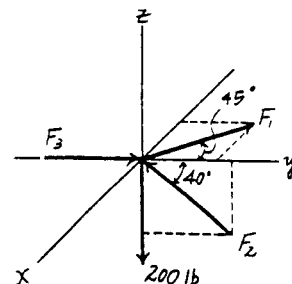

4-1. If A , B , and D are given vectors, prove the distributive law for the vector cross product, i.e., $A \times (B + D) = (A \times B) + (A \times D)$.

Consider the three vectors: with A vertical.

Note abd is perpendicular to A .

$$od = |A \times (B + D)| = |A|(|B + D|) \sin \theta_3$$

$$ob = |A \times B| = |A||B| \sin \theta_1$$

$$bd = |A \times D| = |A||D| \sin \theta_2$$



Also, these three cross products all lie in the plane abd since they are all perpendicular to A . As noted the magnitude of each cross product is proportional to the length of each side of the triangle.

The three vector cross-products also form a closed triangle $o'b'd'$ which is similar to triangle abd . Thus from the figure,

$$A \times (B + D) = A \times B + A \times D \quad (\text{QED})$$

Note also,

$$A = A_x i + A_y j + A_z k$$

$$B = B_x i + B_y j + B_z k$$

$$D = D_x i + D_y j + D_z k$$

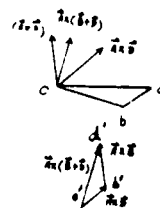

$$\begin{aligned} A \times (B + D) &= \begin{vmatrix} i & j & k \\ A_x & A_y & A_z \\ B_x + D_x & B_y + D_y & B_z + D_z \end{vmatrix} \\ &= [A_y(B_z + D_z) - A_z(B_y + D_y)]i \\ &\quad - [A_x(B_z + D_z) - A_z(B_x + D_x)]j \\ &\quad + [A_x(B_y + D_y) - A_y(B_x + D_x)]k \\ &= [(A_y B_z - A_z B_y) + (A_y D_z - A_z D_y)]i \\ &\quad + [(A_x B_z - A_z B_x) + (A_x D_z - A_z D_x)]j \\ &\quad + [(A_x B_y - A_y B_x) + (A_x D_y - A_y D_x)]k \end{aligned}$$

$$\begin{aligned} &= \begin{vmatrix} i & j & k \\ A_x & A_y & A_z \\ B_x & B_y & B_z \end{vmatrix} + \begin{vmatrix} i & j & k \\ A_x & A_y & A_z \\ D_x & D_y & D_z \end{vmatrix} \\ &= (A \times B) + (A \times D) \quad (\text{QED}) \end{aligned}$$

4-2. Prove the triple scalar product identity $A \cdot B \times C = A \times B \cdot C$.

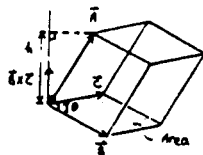

As shown in the figure

$$\text{Area} = B(C \sin \theta) = |B \times C|$$

Thus,

$$\text{Volume of parallelepiped is } |B \times C| |A|$$

But,

$$|A| = |A \cdot \frac{B \times C}{|B \times C|}| = \left| A \cdot \left(\frac{B \times C}{|B \times C|} \right) \right|$$

Thus,

$$\text{Volume} = |A \cdot B \times C|$$

Since $|A \times B \cdot C|$ represents this same volume then

$$A \cdot B \times C = A \times B \cdot C \quad (\text{QED})$$

Also,

$$LHS = A \cdot B \times C$$

$$= (A_x i + A_y j + A_z k) \cdot \begin{vmatrix} i & j & k \\ B_x & B_y & B_z \\ C_x & C_y & C_z \end{vmatrix}$$

$$\begin{aligned} &= A_x(B_y C_z - B_z C_y) - A_y(B_x C_z - B_z C_x) + A_z(B_x C_y - B_y C_x) \\ &= A_x B_y C_z - A_x B_z C_y - A_y B_x C_z + A_y B_z C_x + A_z B_x C_y - A_z B_y C_x \end{aligned}$$

$$RHS = A \times B \cdot C$$

$$= \begin{vmatrix} i & j & k \\ A_x & A_y & A_z \\ B_x & B_y & B_z \end{vmatrix} \cdot (C_x i + C_y j + C_z k)$$

$$\begin{aligned} &= C_x(A_y B_z - A_z B_y) - C_y(A_x B_z - A_z B_x) + C_z(A_x B_y - A_y B_x) \\ &= A_x B_y C_z - A_x B_z C_y - A_y B_x C_z + A_y B_z C_x + A_z B_x C_y - A_z B_y C_x \end{aligned}$$

Thus, $LHS = RHS$

$$A \cdot B \times C = A \times B \cdot C \quad (\text{QED})$$

4-3. Given the three nonzero vectors **A**, **B**, and **C**, show that if $\mathbf{A} \cdot (\mathbf{B} \times \mathbf{C}) = 0$, the three vectors *must* lie in the same plane.

Consider,

$$\begin{aligned} |\mathbf{A} \cdot (\mathbf{B} \times \mathbf{C})| &= |\mathbf{A}| |\mathbf{B} \times \mathbf{C}| \cos \theta \\ &= (|\mathbf{A}| \cos \theta) |\mathbf{B} \times \mathbf{C}| \\ &= |h| |\mathbf{B} \times \mathbf{C}| \\ &= BC |h| \sin \phi \\ &= \text{volume of parallelepiped.} \end{aligned}$$

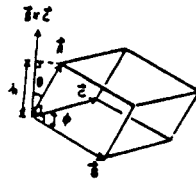

If $\mathbf{A} \cdot (\mathbf{B} \times \mathbf{C}) = 0$, then the volume equals zero, so that **A**, **B**, and **C** are coplanar.

*4-4. Determine the magnitude and directional sense of the moment of the force at **A** about point **O**.

$$\begin{aligned} \zeta^+ M_O &= 400 \cos 30^\circ (5) + 400 \sin 30^\circ (2) \\ &= 2132 \text{ N} \cdot \text{m} \\ &= 2.13 \text{ kN} \cdot \text{m} \quad (\text{Counterclockwise}) \quad \text{Ans} \end{aligned}$$

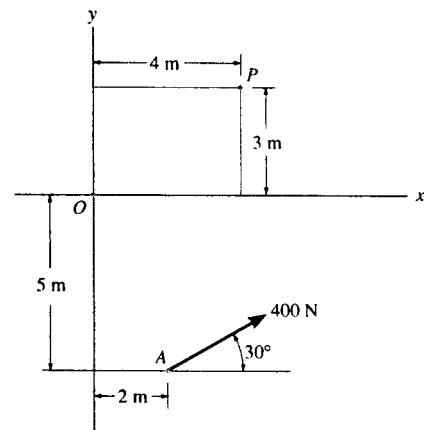

4-5. Determine the magnitude and directional sense of the moment of the force at **A** about point **P**.

$$\begin{aligned} \zeta^+ M_P &= 400 \cos 30^\circ (8) - 400 \sin 30^\circ (2) \\ &= 2371 \text{ N} \cdot \text{m} \\ &= 2.37 \text{ kN} \cdot \text{m} \quad (\text{Counterclockwise}) \quad \text{Ans} \end{aligned}$$

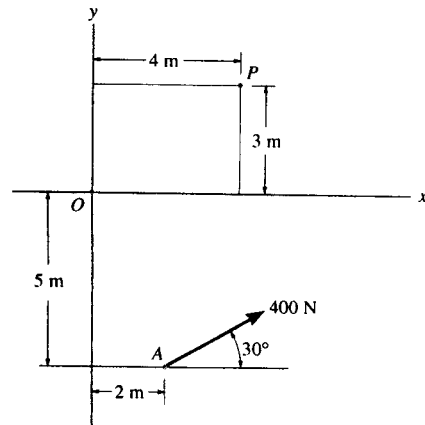

4-6. Determine the magnitude and directional sense of the moment of the force at A about point O .

$$\begin{aligned} \zeta + M_O &= 520 \left(\frac{12}{13} \right) (6) \\ &= 2880 \text{ N}\cdot\text{m} = 2.88 \text{ kN}\cdot\text{m} \quad (\text{Counterclockwise}) \quad \text{Ans} \end{aligned}$$

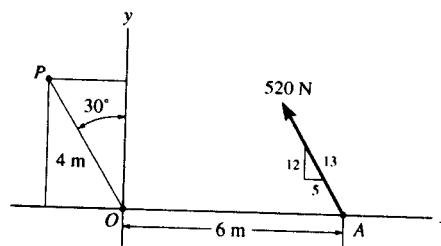

4-7. Determine the magnitude and directional sense of the moment of the force at A about point P .

$$\begin{aligned} \zeta + M_P &= 520 \left(\frac{12}{13} \right) (6 + 4 \sin 30^\circ) - 520 \left(\frac{5}{13} \right) (4 \cos 30^\circ) \\ &= 3147 \text{ N}\cdot\text{m} \\ &= 3.15 \text{ kN}\cdot\text{m} \quad (\text{Counterclockwise}) \quad \text{Ans} \end{aligned}$$

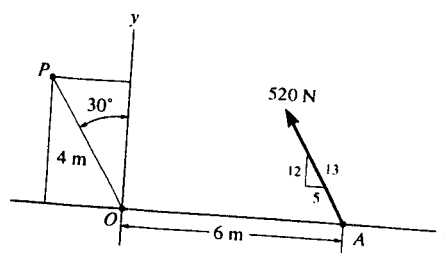

*4-8. Determine the magnitude and directional sense of the resultant moment of the forces about point O .

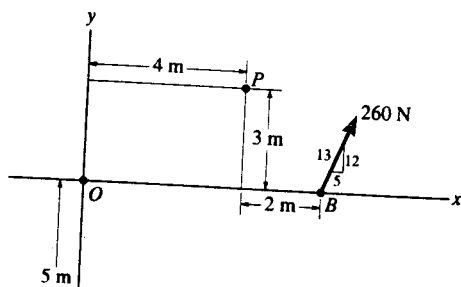

$$\begin{aligned} \zeta + M_O &= 400 \sin 30^\circ (2) + 400 \cos 30^\circ (5) + 260 \left(\frac{12}{13} \right) (6) \\ &= 3572.1 \text{ N}\cdot\text{m} = 3.57 \text{ kN}\cdot\text{m} \quad \text{Ans} \end{aligned}$$

4-9. Determine the magnitude and directional sense of the resultant moment of the forces about point P .

$$\begin{aligned} \zeta + M_P &= 260 \left(\frac{5}{13} \right) (3) + 260 \left(\frac{12}{13} \right) (2) - 400 \sin 30^\circ (2) + 400 \cos 30^\circ (8) \\ &= 3151 \text{ N}\cdot\text{m} = 3.15 \text{ kN}\cdot\text{m} \quad \text{Ans} \end{aligned}$$

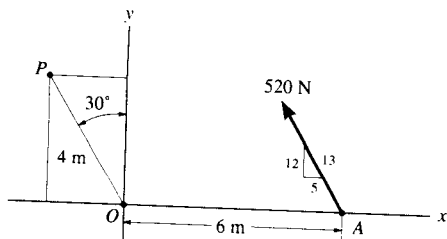

4-10. The wrench is used to loosen the bolt. Determine the moment of each force about the bolt's axis passing through point O .

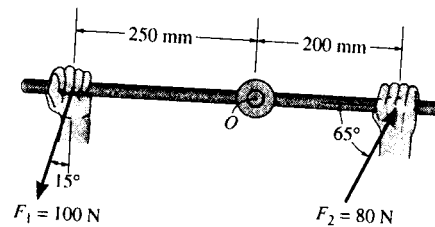

$$\begin{aligned} \zeta^+ (M_{F_1})_O &= 100 \cos 15^\circ (0.25) \\ &= 24.1 \text{ N}\cdot\text{m} \quad (\text{Counterclockwise}) \quad \text{Ans} \end{aligned}$$

$$\begin{aligned} \zeta^+ (M_{F_2})_O &= 80 \sin 65^\circ (0.2) \\ &= 14.5 \text{ N}\cdot\text{m} \quad (\text{Counterclockwise}) \quad \text{Ans} \end{aligned}$$

4-11. Determine the magnitude and directional sense of the resultant moment of the forces about point O .

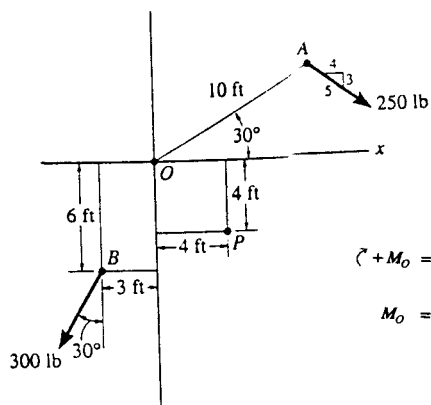

$$\zeta^+ M_O = 250\left(\frac{4}{5}\right)(10 \sin 30^\circ) + 250\left(\frac{3}{5}\right)(10 \cos 30^\circ) + 300(\sin 30^\circ)(6) - 300(\cos 30^\circ)(3)$$

$$M_O = 2419.62 \text{ lb}\cdot\text{ft} = 2.42 \text{ kip}\cdot\text{ft} \quad \text{Ans}$$

*4-12. Determine the moment about point A of each of the three forces acting on the beam.

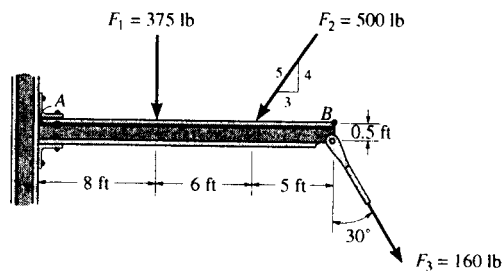

$$\begin{aligned} \zeta^+ (M_{F_1})_A &= -375(8) \\ &= -3000 \text{ lb}\cdot\text{ft} = 3.00 \text{ kip}\cdot\text{ft} \quad (\text{Clockwise}) \quad \text{Ans} \end{aligned}$$

$$\begin{aligned} \zeta^+ (M_{F_2})_A &= -500\left(\frac{4}{5}\right)(14) \\ &= -5600 \text{ lb}\cdot\text{ft} = 5.60 \text{ kip}\cdot\text{ft} \quad (\text{Clockwise}) \quad \text{Ans} \end{aligned}$$

$$\begin{aligned} \zeta^+ (M_{F_3})_A &= -160(\cos 30^\circ)(19) + 160 \sin 30^\circ (0.5) \\ &= -2593 \text{ lb}\cdot\text{ft} = 2.59 \text{ kip}\cdot\text{ft} \quad (\text{Clockwise}) \quad \text{Ans} \end{aligned}$$

4-13. Determine the moment about point B of each of the three forces acting on the beam.

$$\begin{aligned} \curvearrowleft (M_{F_1})_B &= 375(11) \\ &= 4125 \text{ lb}\cdot\text{ft} = 4.125 \text{ kip}\cdot\text{ft} \quad (\text{Counterclockwise}) \quad \text{Ans} \end{aligned}$$

$$\begin{aligned} \curvearrowleft (M_{F_2})_B &= 500\left(\frac{4}{5}\right)(5) \\ &= 2000 \text{ lb}\cdot\text{ft} = 2.00 \text{ kip}\cdot\text{ft} \quad (\text{Counterclockwise}) \quad \text{Ans} \end{aligned}$$

$$\begin{aligned} \curvearrowleft (M_{F_3})_B &= 160\sin 30^\circ(0.5) - 160\cos 30^\circ(0) \\ &= 40.0 \text{ lb}\cdot\text{ft} \quad (\text{Counterclockwise}) \quad \text{Ans} \end{aligned}$$

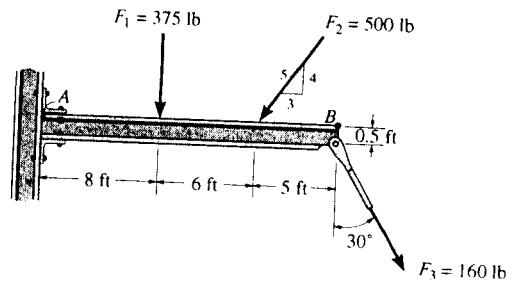

4-14. Determine the moment of each force about the bolt located at A . Take $F_B = 40 \text{ lb}$, $F_C = 50 \text{ lb}$.

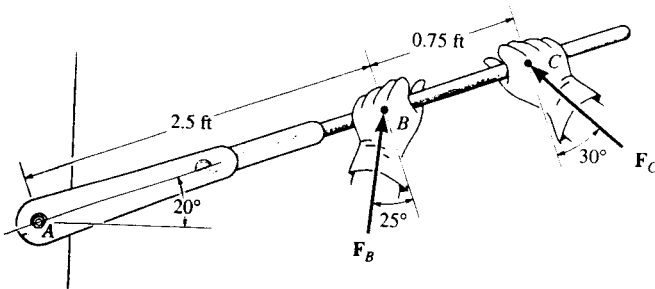

$$\curvearrowleft +M_B = 40 \cos 25^\circ(2.5) = 90.6 \text{ lb}\cdot\text{ft} \quad \text{Ans}$$

$$\curvearrowleft +M_C = 50 \cos 30^\circ(3.25) = 141 \text{ lb}\cdot\text{ft} \quad \text{Ans}$$

4-15. If $F_B = 30 \text{ lb}$ and $F_C = 45 \text{ lb}$, determine the resultant moment about the bolt located at A .

$$\begin{aligned} \curvearrowleft +M_A &= 30 \cos 25^\circ(2.5) + 45 \cos 30^\circ(3.25) \\ &= 195 \text{ lb}\cdot\text{ft} \quad \text{Ans} \end{aligned}$$

*4-16. The power pole supports the three lines, each line exerting a vertical force on the pole due to its weight as shown. Determine the resultant moment at the base D due to all of these forces. If it is possible for wind or ice to snap the lines, determine which line(s) when removed create(s) a condition for the greatest moment about the base. What is this resultant moment?

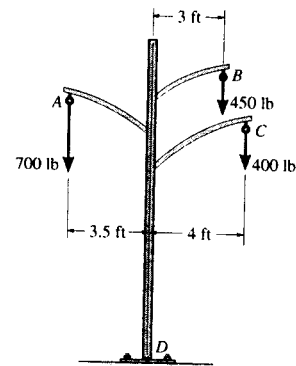

$$\begin{aligned} \curvearrowleft +M_{R_D} = \Sigma Fd; \quad M_{R_D} &= 700(3.5) - 450(3) - 400(4) \\ &= -500 \text{ lb}\cdot\text{ft} = 500 \text{ lb}\cdot\text{ft} \quad (\text{Clockwise}) \quad \text{Ans} \end{aligned}$$

When the cable at A is removed it will create the greatest moment at point D . Ans

$$\begin{aligned} \curvearrowleft + (M_{R_D})_{\max} &= \Sigma Fd; \\ (M_{R_D})_{\max} &= -450(3) - 400(4) \\ &= -2950 \text{ lb}\cdot\text{ft} = 2.95 \text{ kip}\cdot\text{ft} \quad (\text{Clockwise}) \quad \text{Ans} \end{aligned}$$

4-17. A force of 80 N acts on the handle of the paper cutter at A. Determine the moment created by this force about the hinge at O, if $\theta = 60^\circ$. At what angle θ should the force be applied so that the moment it creates about point O is a maximum (clockwise)? What is this maximum moment?

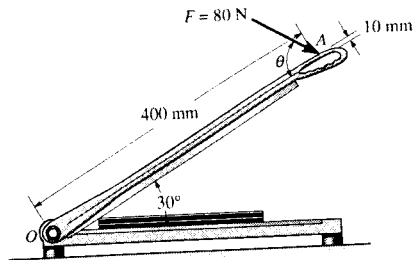

$$\begin{aligned} \curvearrowright +M_o &= \Sigma Fd; \quad M_o = -80 \cos \theta (0.01) - 80 \sin \theta (0.4) \\ &= -(0.800 \cos \theta + 32.0 \sin \theta) \text{ N} \cdot \text{m} \\ &= (0.800 \cos \theta + 32.0 \sin \theta) \text{ N} \cdot \text{m} \text{ (Clockwise)} \end{aligned}$$

$$\begin{aligned} \text{At } \theta = 60^\circ, \quad M_o &= 0.800 \cos 60^\circ + 32.0 \sin 60^\circ \\ &= 28.1 \text{ N} \cdot \text{m} \text{ (Clockwise)} \quad \text{Ans} \end{aligned}$$

In order to produce the maximum and minimum moment about point A, $\frac{dM_o}{d\theta} = 0$

$$\begin{aligned} \frac{dM_o}{d\theta} &= 0 = -0.800 \sin \theta + 32.0 \cos \theta \\ \theta &= 88.568^\circ = 88.6^\circ \quad \text{Ans} \end{aligned}$$

$$\begin{aligned} \frac{d^2 M_o}{d\theta^2} &= -0.800 \cos \theta - 32.0 \sin \theta \\ \text{Since } \left. \frac{d^2 M_o}{d\theta^2} \right|_{\theta=88.568^\circ} &= -0.800 \cos 88.568^\circ - 32.0 \sin 88.568^\circ = \\ &= -32.00 \text{ is a negative value, indeed at } \theta = 88.568^\circ, \text{ the } 80 \text{ N produces a maximum clockwise moment at } O. \text{ This maximum clockwise moment is} \end{aligned}$$

$$\begin{aligned} (M_o)_{\max} &= 0.800 \cos 88.568^\circ + 32.0 \sin 88.568^\circ \\ &= 32.0 \text{ N} \cdot \text{m} \text{ (Clockwise)} \quad \text{Ans} \end{aligned}$$

4-18. Determine the direction θ ($0^\circ \leq \theta \leq 180^\circ$) of the force $F = 40$ lb so that it produces (a) the maximum moment about point A and (b) the minimum moment about point A. Compute the moment in each case.

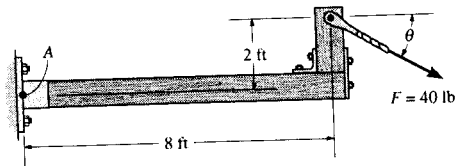

$$(a) \quad \curvearrowright + (M_A)_{\max} = 40(\sqrt{8^2 + 2^2}) = 330 \text{ lb} \cdot \text{ft} \quad \text{Ans}$$

$$\phi = \tan^{-1} \left(\frac{2}{8} \right) = 14.04^\circ$$

$$\theta = 90^\circ - 14.04^\circ = 76.0^\circ \quad \text{Ans}$$

$$(b) \quad \curvearrowright + (M_A)_{\min} = 0 \quad \text{Ans}$$

$$\phi = \tan^{-1} \left(\frac{2}{8} \right) = 14.04^\circ$$

$$\theta = 180^\circ - 14.04^\circ = 166^\circ \quad \text{Ans}$$

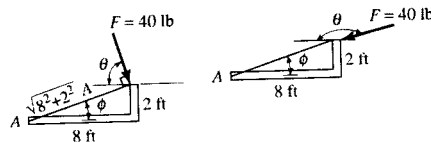

*4-19. The hub of the wheel can be attached to the axle either with negative offset (left) or with positive offset (right). If the tire is subjected to both a normal and radial load as shown, determine the resultant moment of these loads about the axle, point O for both cases.

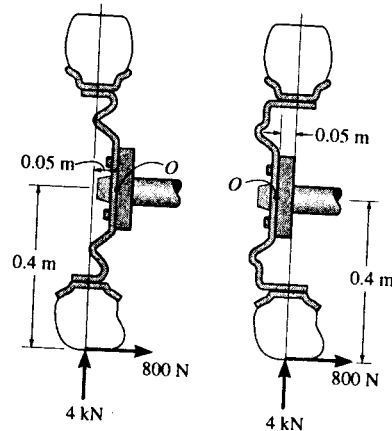

For case 1 with negative offset, we have

$$\begin{aligned} \zeta + M_O &= 800(0.4) - 4000(0.05) \\ &= 120 \text{ N}\cdot\text{m} \quad (\text{Counterclockwise}) \quad \text{Ans} \end{aligned}$$

For case 2 with positive offset, we have

$$\begin{aligned} \zeta + M_O &= 800(0.4) + 4000(0.05) \\ &= 520 \text{ N}\cdot\text{m} \quad (\text{Counterclockwise}) \quad \text{Ans} \end{aligned}$$

*4-20. The boom has a length of 30 ft, a weight of 800 lb, and mass center at G . If the maximum moment that can be developed by the motor at A is $M = 20(10^3)$ lb·ft, determine the maximum load W , having a mass center at G' , that can be lifted. Take $\theta = 30^\circ$.

$$20(10^3) = 800(16 \cos 30^\circ) + W(30 \cos 30^\circ + 2)$$

$$W = 319 \text{ lb} \quad \text{Ans}$$

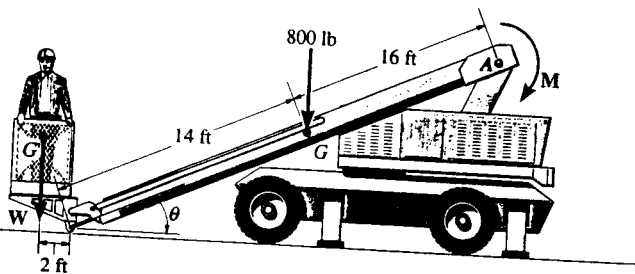

4-21. The tool at A is used to hold a power lawnmower blade stationary while the nut is being loosened with the wrench. If a force of 50 N is applied to the wrench at B in the direction shown, determine the moment it creates about the nut at C . What is the magnitude of force F at A so that it creates the opposite moment about C ?

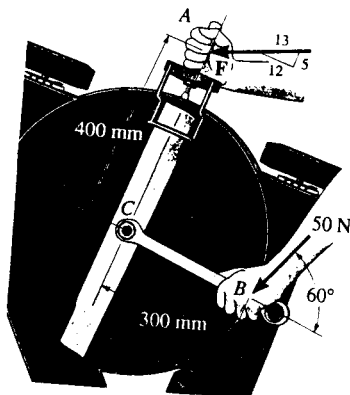

$$(a) \zeta + M_A = 50 \sin 60^\circ (0.3)$$

$$M_A = 12.99 = 13.0 \text{ N}\cdot\text{m} \quad \text{Ans}$$

$$(b) \zeta + M_A = 0; \quad -12.99 + F\left(\frac{12}{13}\right)(0.4) = 0$$

$$F = 35.2 \text{ N} \quad \text{Ans}$$

4-22. Determine the moment of each of the three forces about point A. Solve the problem first by using each force as a whole, and then by using the principle of moments.

The moment arm measured perpendicular to each force from point A is

$$\begin{aligned} d_1 &= 2 \sin 60^\circ = 1.732 \text{ m} \\ d_2 &= 5 \sin 60^\circ = 4.330 \text{ m} \\ d_3 &= 2 \sin 53.13^\circ = 1.60 \text{ m} \end{aligned}$$

Using each force where $M_A = Fd$, we have

$$\begin{aligned} \sum (+ (M_{F_1})_A &= -250(1.732) \\ &= -433 \text{ N} \cdot \text{m} = 433 \text{ N} \cdot \text{m} \quad (\text{Clockwise}) \quad \text{Ans} \end{aligned}$$

$$\begin{aligned} \sum (+ (M_{F_2})_A &= -300(4.330) \\ &= -1299 \text{ N} \cdot \text{m} = 1.30 \text{ kN} \cdot \text{m} \quad (\text{Clockwise}) \quad \text{Ans} \end{aligned}$$

$$\begin{aligned} \sum (+ (M_{F_3})_A &= -500(1.60) \\ &= -800 \text{ N} \cdot \text{m} = 800 \text{ N} \cdot \text{m} \quad (\text{Clockwise}) \quad \text{Ans} \end{aligned}$$

Using principle of moments, we have

$$\begin{aligned} \sum (+ (M_{F_1})_A &= -250 \cos 30^\circ (2) \\ &= -433 \text{ N} \cdot \text{m} = 433 \text{ N} \cdot \text{m} \quad (\text{Clockwise}) \quad \text{Ans} \end{aligned}$$

$$\begin{aligned} \sum (+ (M_{F_2})_A &= -300 \sin 60^\circ (5) \\ &= -1299 \text{ N} \cdot \text{m} = 1.30 \text{ kN} \cdot \text{m} \quad (\text{Clockwise}) \quad \text{Ans} \end{aligned}$$

$$\begin{aligned} \sum (+ (M_{F_3})_A &= 500 \left(\frac{3}{5}\right)(4) - 500 \left(\frac{4}{5}\right)(5) \\ &= -800 \text{ N} \cdot \text{m} = 800 \text{ N} \cdot \text{m} \quad (\text{Clockwise}) \quad \text{Ans} \end{aligned}$$

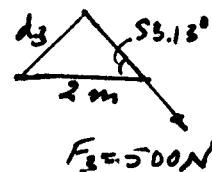
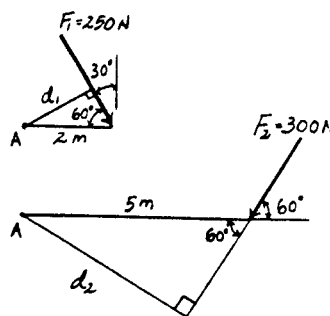
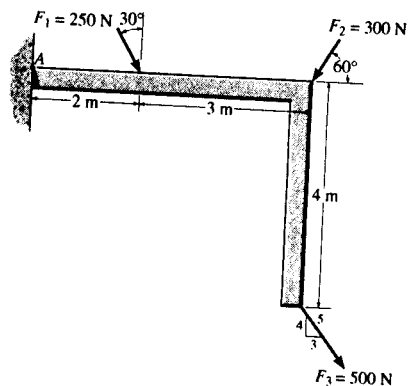

4-23. As part of an acrobatic stunt, a man supports a girl who has a weight of 120 lb and is seated on a chair on top of the pole. If her center of gravity is at G, and if the maximum counterclockwise moment the man can exert on the pole at A is 250 lb·ft, determine the maximum angle of tilt, θ , which will not allow the girl to fall, i.e., so her clockwise moment about A does not exceed 250 lb·ft.

In order to prevent the girl from falling down, the clockwise moment produced by the girl's weight must not exceed 250 lb·ft.

$$\begin{aligned} M_A &= 120(16 \sin \theta) \leq 250 \\ \sin \theta &\leq 0.1302 \end{aligned}$$

$$\theta = 7.48^\circ$$

Ans

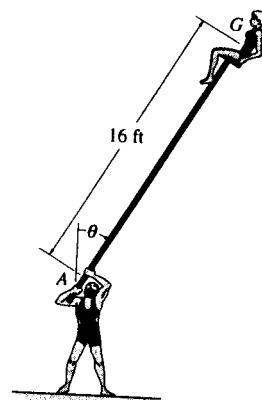

4-24. The two boys push on the gate with forces of $F_A = 30$ lb and $F_B = 50$ lb as shown. Determine the moment of each force about C . Which way will the gate rotate, clockwise or counterclockwise? Neglect the thickness of the gate.

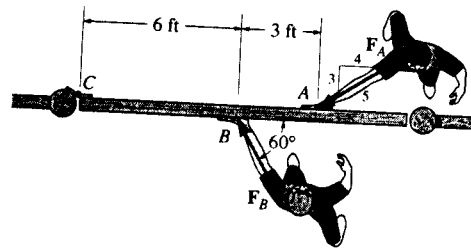

$$\begin{aligned} (+) (M_{F_A})_C &= -30\left(\frac{3}{5}\right)(9) \\ &= -162 \text{ lb} \cdot \text{ft} = 162 \text{ lb} \cdot \text{ft} \quad (\text{Clockwise}) \quad \text{Ans} \end{aligned}$$

$$\begin{aligned} (+) (M_{F_B})_C &= 50(\sin 60^\circ)(6) \\ &= 260 \text{ lb} \cdot \text{ft} \quad (\text{Counterclockwise}) \quad \text{Ans} \end{aligned}$$

Since $(M_{F_B})_C > (M_{F_A})_C$, the gate will rotate *Counterclockwise*. Ans

4-25. Two boys push on the gate as shown. If the boy at B exerts a force of $F_B = 30$ lb, determine the magnitude of the force F_A the boy at A must exert in order to prevent the gate from turning. Neglect the thickness of the gate.

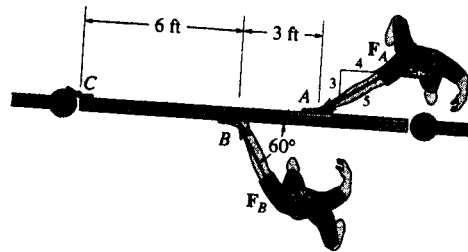

In order to prevent the gate from turning, the resultant moment about point C must be equal to zero.

$$+ M_{R_C} = \Sigma Fd; \quad M_{R_C} = 0 = 30 \sin 60^\circ (6) - F_A \left(\frac{3}{5}\right)(9)$$

$$F_A = 28.9 \text{ lb} \quad \text{Ans}$$

4-26. The towline exerts a force of $P = 4 \text{ kN}$ at the end of the 20-m-long crane boom. If $\theta = 30^\circ$, determine the placement x of the hook at A so that this force creates a maximum moment about point O . What is this moment?

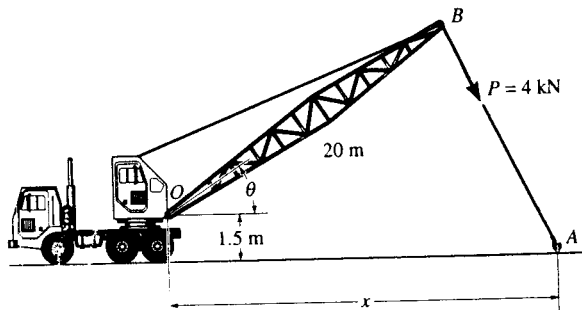

Maximum moment, $OB \perp BA$

$$\zeta^+ (M_O)_{max} = 4000(20) = 80 \text{ kN}\cdot\text{m} \quad \text{Ans}$$

$$4 \text{ kN} \sin 60^\circ(x) - 4 \text{ kN} \cos 60^\circ(1.5) = 80 \text{ kN}\cdot\text{m}$$

$$x = 24.0 \text{ m} \quad \text{Ans}$$

4-27. The towline exerts a force of $P = 4 \text{ kN}$ at the end of the 20-m-long crane boom. If $x = 25 \text{ m}$, determine the position θ of the boom so that this force creates a maximum moment about point O . What is this moment?

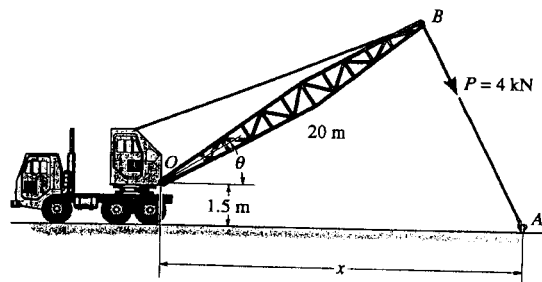

Maximum moment, $OB \perp BA$

$$\zeta^+ (M_O)_{max} = 4000(20) = 80\,000 \text{ N}\cdot\text{m} = 80.0 \text{ kN}\cdot\text{m} \quad \text{Ans}$$

$$4000 \sin \phi(25) - 4000 \cos \phi(1.5) = 80\,000$$

$$25 \sin \phi - 1.5 \cos \phi = 20$$

$$\phi = 56.43^\circ$$

$$\theta = 90^\circ - 56.43^\circ = 33.6^\circ \quad \text{Ans}$$

Also,

$$(1.5)^2 + z^2 = y^2$$

$$2.25 + z^2 = y^2$$

Similar triangles

$$\frac{20+y}{z} = \frac{25+z}{y}$$

$$20y + y^2 = 25z + z^2$$

$$20(\sqrt{2.25 + z^2}) + 2.25 + z^2 = 25z + z^2$$

$$z = 2.259 \text{ m}$$

$$y = 2.712 \text{ m}$$

$$\theta = \cos^{-1}\left(\frac{2.259}{2.712}\right) = 33.6^\circ \quad \text{Ans}$$

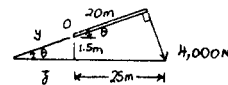
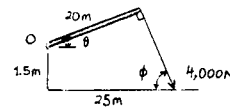

*4-28. Determine the direction θ for $0^\circ \leq \theta \leq 180^\circ$ of the force F so that F produces (a) the maximum moment about point A and (b) the minimum moment about point A . Calculate the moment in each case.

a)

$$\zeta + M_A = 400 \sqrt{(3)^2 + (2)^2} = 1442 \text{ N} \cdot \text{m}$$

$$M_A = 1.44 \text{ kN} \cdot \text{m} \quad \text{Ans}$$

$$\phi = \tan^{-1}\left(\frac{2}{3}\right) = 33.69^\circ$$

$$\theta = 90^\circ - 33.69^\circ = 56.3^\circ \quad \text{Ans}$$

b)

$$\zeta + M_A = 0 \quad \text{Ans}$$

$$\phi = \tan^{-1}\left(\frac{2}{3}\right) = 33.69^\circ$$

$$\theta = 180^\circ - 33.69^\circ = 146^\circ \quad \text{Ans}$$

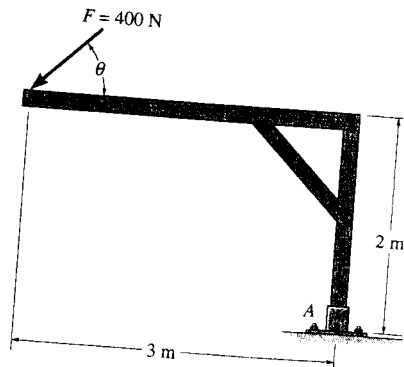
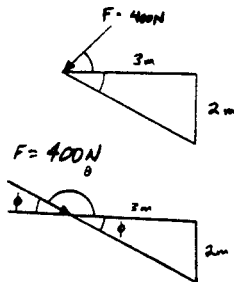

4-29. Determine the moment of the force F about point A as a function of θ . Plot the results of M (ordinate) versus θ (abscissa) for $0^\circ \leq \theta \leq 180^\circ$.

$$\zeta + M_A = 400 \sin\theta(3) + 400 \cos\theta(2)$$

$$= 1200 \sin\theta + 800 \cos\theta \quad \text{Ans}$$

$$\frac{dM_A}{d\theta} = 1200 \cos\theta - 800 \sin\theta = 0$$

$$\theta = \tan^{-1}\left(\frac{1200}{800}\right) = 56.3^\circ$$

$$(M_A)_{\max} = 1200 \sin 56.3^\circ + 800 \cos 56.3^\circ = 1442 \text{ N} \cdot \text{m}$$

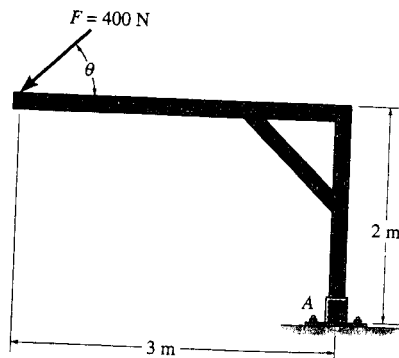
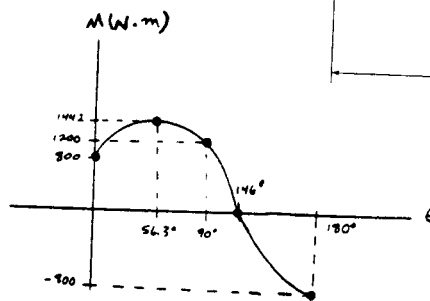

***4-28.** Determine the direction θ for $0^\circ \leq \theta \leq 180^\circ$ of the force F so that F produces (a) the maximum moment about point A and (b) the minimum moment about point A . Calculate the moment in each case.

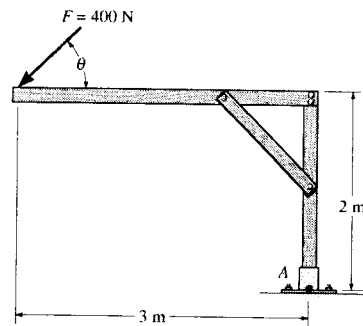

(a) $\curvearrowleft +M_A = 400\sqrt{(3)^2 + (2)^2} = 1442 \text{ N} \cdot \text{m}$

$M_A = 1.44 \text{ kN} \cdot \text{m}$ **Ans**

$\phi = \tan^{-1}\left(\frac{2}{3}\right) = 33.69^\circ$

$\theta = 90^\circ - 33.69^\circ = 56.3^\circ$ **Ans**

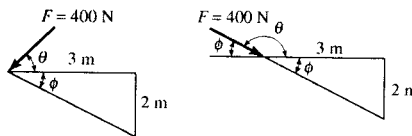

(b) $\curvearrowleft +M_A = 0$ **Ans**

$\phi = \tan^{-1}\left(\frac{2}{3}\right) = 33.69^\circ$

$\theta = 180^\circ - 33.69^\circ = 146^\circ$ **Ans**

4-29. Determine the moment of the force F about point A as a function of θ . Plot the results of M (ordinate) versus θ (abscissa) for $0^\circ \leq \theta \leq 180^\circ$.

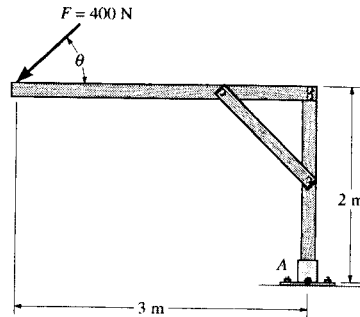

$\curvearrowleft +M_A = 400 \sin \theta(3) + 400 \cos \theta(2)$

$= 1200 \sin \theta + 800 \cos \theta$

$\frac{dM_A}{d\theta} = 1200 \cos \theta - 800 \sin \theta = 0$

$\theta = \tan^{-1}\left(\frac{1200}{800}\right) = 56.3^\circ$

$(M_A)_{\max} = 1200 \sin 56.3^\circ + 800 \cos 56.3^\circ = 1442 \text{ N} \cdot \text{m}$

Ans

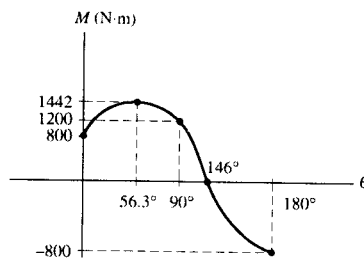

4-30. The total hip replacement is subjected to a force of $F = 120 \text{ N}$. Determine the moment of this force about the neck at A and at the stem B .

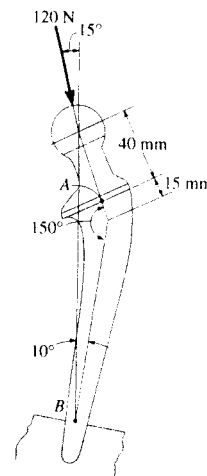

Moment About Point A: The angle between the line of action of the load and the neck axis is $20^\circ - 15^\circ = 5^\circ$.

$$\begin{aligned} (+ M_A &= 120 \sin 5^\circ (0.04) \\ &= 0.418 \text{ N} \cdot \text{m} \quad (\text{Counterclockwise}) \end{aligned} \quad \text{Ans}$$

Moment About Point B: The dimension l can be determined using the law of sines.

$$\frac{l}{\sin 150^\circ} = \frac{55}{\sin 10^\circ} \quad l = 158.4 \text{ mm} = 0.1584 \text{ m}$$

Then,

$$\begin{aligned} + M_B &= -120 \sin 15^\circ (0.1584) \\ &= -4.92 \text{ N} \cdot \text{m} = 4.92 \text{ N} \cdot \text{m} \quad (\text{Clockwise}) \end{aligned} \quad \text{Ans}$$

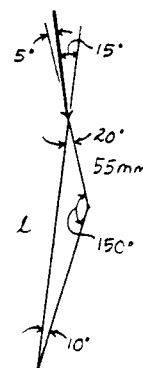

*4-31. The crane can be adjusted for any angle $0^\circ \leq \theta \leq 90^\circ$ and any extension $0 \leq x \leq 5 \text{ m}$. For a suspended mass of 120 kg, determine the moment developed at A as a function of x and θ . What values of both x and θ develop the maximum possible moment at A ? Compute this moment. Neglect the size of the pulley at B .

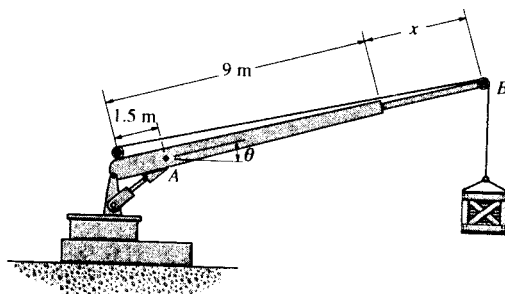

$$\begin{aligned} (+ M_A &= -120(9.81)(7.5+x) \cos \theta \\ &= \{-1177.2 \cos \theta (7.5+x)\} \text{ N} \cdot \text{m} \\ &= \{1.18 \cos \theta (7.5+x)\} \text{ kN} \cdot \text{m} \quad (\text{clockwise}) \end{aligned} \quad \text{Ans}$$

The maximum moment at A occurs when $\theta = 0^\circ$ and $x = 5 \text{ m}$. Ans

$$\begin{aligned} (+ (M_A)_{\max} &= \{-1177.2 \cos 0^\circ (7.5+5)\} \text{ N} \cdot \text{m} \\ &= -14715 \text{ N} \cdot \text{m} \\ &= 14.7 \text{ kN} \cdot \text{m} \quad (\text{clockwise}) \end{aligned} \quad \text{Ans}$$

***4-32.** Determine the angle θ at which the 500-N force must act at A so that the moment of this force about point B is equal to zero.

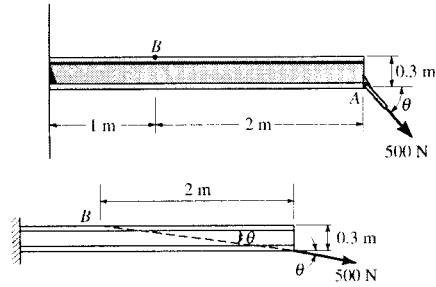

This problem requires that the resultant moment about point B be equal to zero.

$$\curvearrowleft +M_R = \Sigma Fd; \quad M_R = 0 = 500 \cos \theta(0.3) - 500 \sin \theta(2)$$

$$\theta = 8.53^\circ$$

Ans

Also note that if the line of action of the 500 N force passes through point B , it produces zero moment about B . Hence, from the geometry

$$\theta = \tan^{-1} \left(\frac{0.3}{2} \right) = 8.53^\circ$$

4-33. Segments of drill pipe D for an oil well are tightened a prescribed amount by using a set of tongs T , which grip the pipe, and a hydraulic cylinder (not shown) to regulate the force F applied to the tongs. This force acts along the cable which passes around the small pulley P . If the cable is originally perpendicular to the tongs as shown, determine the magnitude of force F which must be applied so that the moment about the pipe is $M = 2000 \text{ lb} \cdot \text{ft}$. In order to maintain this same moment what magnitude of F is required when the tongs rotate 30° to the dashed position? *Note:* The angle DAP is not 90° in this position.

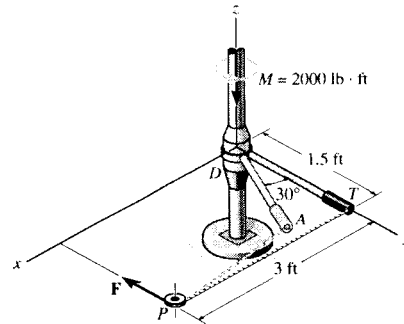

This problem requires that the moment produced by F and F' about the z axis is $2000 \text{ lb} \cdot \text{ft}$.

$$M_z = 2000 = F(1.5)$$

$$F = 1333.3 \text{ lb} = 1.33 \text{ kip}$$

Ans

$$F = F' \cos \theta, \text{ where}$$

$$\theta = 30^\circ + \tan^{-1} \left(\frac{1.5 - 1.5 \cos 30^\circ}{2.25} \right)$$

$$= 35.104^\circ$$

$$F' = \frac{1333.33}{\cos 35.104^\circ} = 1.63 \text{ kip}$$

Ans

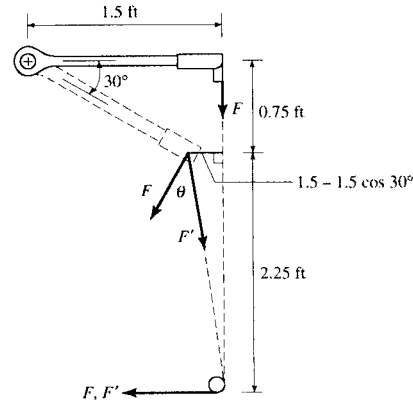

- 4-34. Determine the moment of the force at A about point O . Express the result as a Cartesian vector.

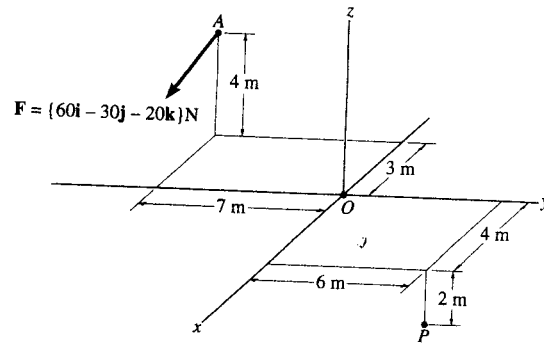

Position Vector :

$$\begin{aligned} r_{OA} &= \{(-3-0)\mathbf{i} + (-7-0)\mathbf{j} + (4-0)\mathbf{k}\} \text{ m} \\ &= \{-3\mathbf{i} - 7\mathbf{j} + 4\mathbf{k}\} \text{ m} \end{aligned}$$

Moment of Force F About Point O : Applying Eq. 4-7, we have

$$\begin{aligned} M_O &= r_{OA} \times F \\ &= \begin{vmatrix} \mathbf{i} & \mathbf{j} & \mathbf{k} \\ -3 & -7 & 4 \\ 60 & -30 & -20 \end{vmatrix} \\ &= \{260\mathbf{i} + 180\mathbf{j} + 510\mathbf{k}\} \text{ N}\cdot\text{m} \end{aligned} \quad \text{Ans}$$

- 4-35. Determine the moment of the force at A about point P . Express the result as a Cartesian vector.

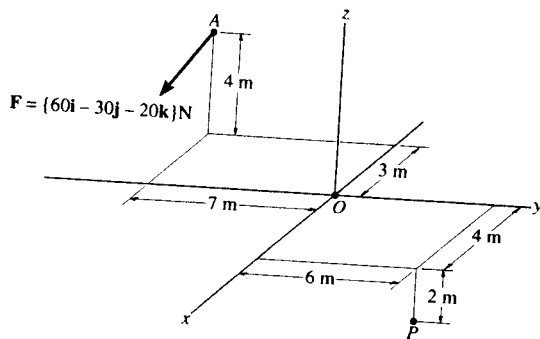

Position Vector :

$$\begin{aligned} r_{PA} &= \{(-3-4)\mathbf{i} + (-7-6)\mathbf{j} + [4-(-2)]\mathbf{k}\} \text{ m} \\ &= \{-7\mathbf{i} - 13\mathbf{j} + 6\mathbf{k}\} \text{ m} \end{aligned}$$

Moment of Force F About Point O : Applying Eq. 4-7, we have

$$\begin{aligned} M_O &= r_{PA} \times F \\ &= \begin{vmatrix} \mathbf{i} & \mathbf{j} & \mathbf{k} \\ -7 & -13 & 6 \\ 60 & -30 & -20 \end{vmatrix} \\ &= \{440\mathbf{i} + 220\mathbf{j} + 990\mathbf{k}\} \text{ N}\cdot\text{m} \end{aligned} \quad \text{Ans}$$

*4-36. Determine the moment of the force F at A about point O . Express the result as a Cartesian vector.

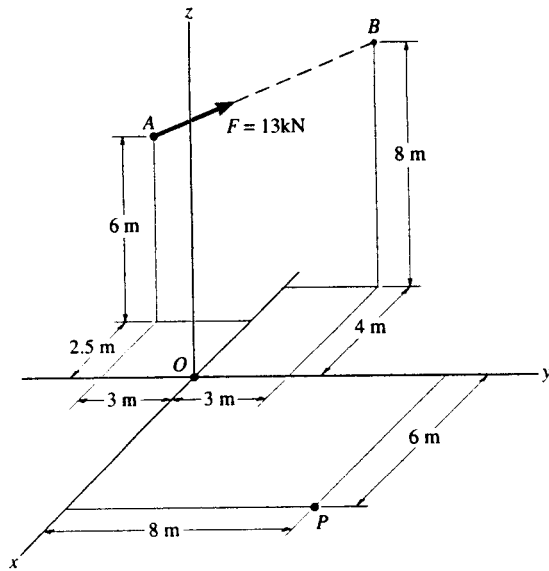

$$\mathbf{r}_{AB} = \{-1.5\mathbf{i} + 6\mathbf{j} + 2\mathbf{k}\} \text{ m}$$

$$r_{AB} = \sqrt{(-1.5)^2 + 6^2 + 2^2} = 6.5 \text{ m}$$

$$\mathbf{M}_O = \mathbf{r}_{OA} \times \mathbf{F} = \begin{vmatrix} \mathbf{i} & \mathbf{j} & \mathbf{k} \\ -2.5 & -3 & 6 \\ -\frac{1.5}{6.5}(13) & \frac{6}{6.5}(13) & \frac{2}{6.5}(13) \end{vmatrix}$$

$$\mathbf{M}_O = \{-84\mathbf{i} - 8\mathbf{j} - 39\mathbf{k}\} \text{ kN}\cdot\text{m} \quad \text{Ans}$$

4-37. Determine the moment of the force F at A about point P . Express the result as a Cartesian vector.

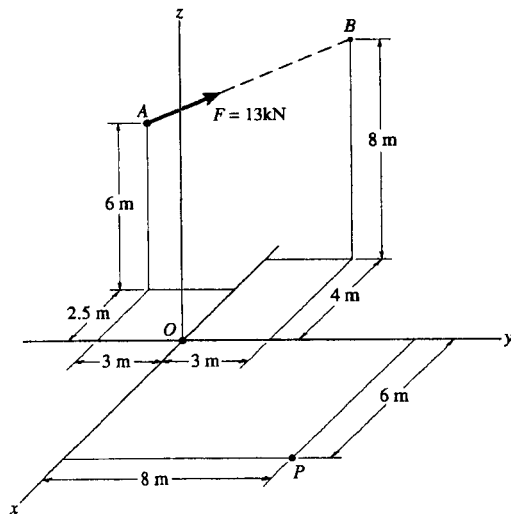

$$\mathbf{M}_P = \mathbf{r}_{PA} \times \mathbf{F} = \begin{vmatrix} \mathbf{i} & \mathbf{j} & \mathbf{k} \\ -8.5 & -11 & 6 \\ -\frac{1.5}{6.5}(13) & \frac{6}{6.5}(13) & \frac{2}{6.5}(13) \end{vmatrix}$$

$$\mathbf{M}_P = \{-116\mathbf{i} + 16\mathbf{j} - 135\mathbf{k}\} \text{ kN}\cdot\text{m} \quad \text{Ans}$$

4-38. The curved rod lies in the x - y plane and has a radius of 3 m. If a force of $F = 80$ N acts at its end as shown, determine the moment of this force about point O .

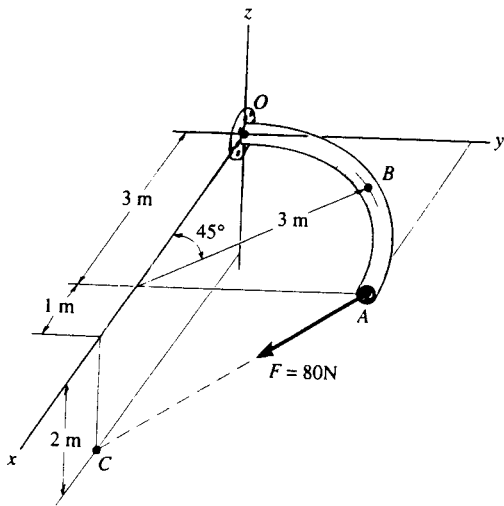

$$r_{AC} = \{1i - 3j - 2k\} \text{ m}$$

$$r_{AC} = \sqrt{(1)^2 + (-3)^2 + (-2)^2} = 3.742 \text{ m}$$

$$M_O = r_{OC} \times F = \begin{vmatrix} i & j & k \\ 4 & 0 & -2 \\ \frac{1}{3.742}(80) & -\frac{3}{3.742}(80) & -\frac{2}{3.742}(80) \end{vmatrix}$$

$$M_O = \{-128i + 128j - 257k\} \text{ N}\cdot\text{m} \quad \text{Ans}$$

4-39. The curved rod lies in the x - y plane and has a radius of 3 m. If a force of $F = 80$ N acts at its end as shown, determine the moment of this force about point B .

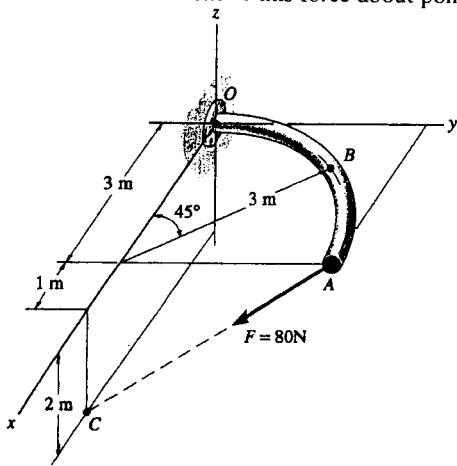

$$r_{AC} = \{1i - 3j - 2k\} \text{ m}$$

$$r_{AC} = \sqrt{(1)^2 + (-3)^2 + (-2)^2} = 3.742 \text{ m}$$

$$M_B = r_{BA} \times F = \begin{vmatrix} i & j & k \\ 3\cos 45^\circ & (3 - 3\sin 45^\circ) & 0 \\ \frac{1}{3.742}(80) & -\frac{3}{3.742}(80) & -\frac{2}{3.742}(80) \end{vmatrix}$$

$$M_B = \{-37.6i + 90.7j - 155k\} \text{ N}\cdot\text{m} \quad \text{Ans}$$

*4-40. The force $F = \{600i + 300j - 600k\}$ N acts at the end of the beam. Determine the moment of the force about point A .

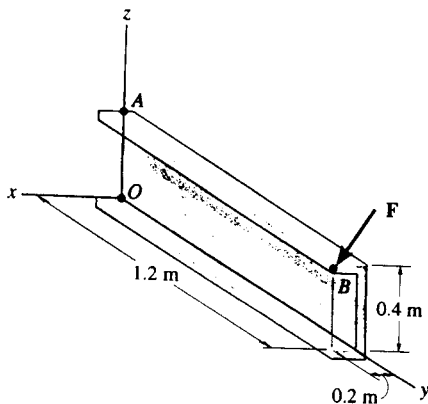

$$r = \{0.2i + 1.2j\} \text{ m}$$

$$M_A = r_{AB} \times F = \begin{vmatrix} i & j & k \\ 0.2 & 1.2 & 0 \\ 600 & 300 & -600 \end{vmatrix}$$

$$M_A = \{-720i + 120j - 660k\} \text{ N}\cdot\text{m} \quad \text{Ans}$$

4-41. The curved rod has a radius of 5 ft. If a force of 60 lb acts at its end as shown, determine the moment of this force about point C.

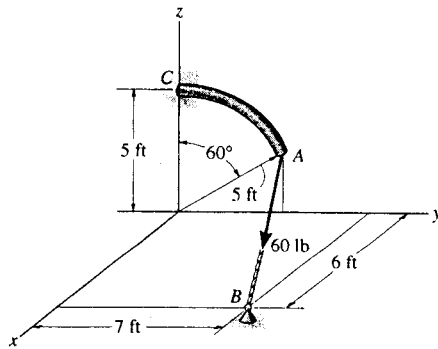

Position Vector and Force Vector :

$$\mathbf{r}_{CA} = \{(5 \sin 60^\circ - 0)\mathbf{j} + (5 \cos 60^\circ - 5)\mathbf{k}\} \text{ m}$$

$$= \{4.330\mathbf{j} - 2.50\mathbf{k}\} \text{ m}$$

$$\mathbf{F}_{AB} = 60 \left(\frac{(6-0)\mathbf{i} + (7-5 \sin 60^\circ)\mathbf{j} + (0-5 \cos 60^\circ)\mathbf{k}}{\sqrt{(6-0)^2 + (7-5 \sin 60^\circ)^2 + (0-5 \cos 60^\circ)^2}} \right) \text{ lb}$$

$$= \{51.231\mathbf{i} + 22.797\mathbf{j} - 21.346\mathbf{k}\} \text{ lb}$$

Moment of Force \mathbf{F}_{AB} About Point C : Applying Eq. 4-7, we have

$$\mathbf{M}_C = \mathbf{r}_{CA} \times \mathbf{F}_{AB}$$

$$= \begin{vmatrix} \mathbf{i} & \mathbf{j} & \mathbf{k} \\ 0 & 4.330 & -2.50 \\ 51.231 & 22.797 & -21.346 \end{vmatrix}$$

$$= \{-35.4\mathbf{i} - 128\mathbf{j} - 222\mathbf{k}\} \text{ lb} \cdot \text{ft} \quad \text{Ans}$$

4-42. A force \mathbf{F} having a magnitude of $F = 100 \text{ N}$ along the diagonal of the parallelepiped. Determine the moment of \mathbf{F} about point A, using $\mathbf{M}_A = \mathbf{r}_B \times \mathbf{F}$ and $\mathbf{M}_A = \mathbf{r}_C \times \mathbf{F}$.

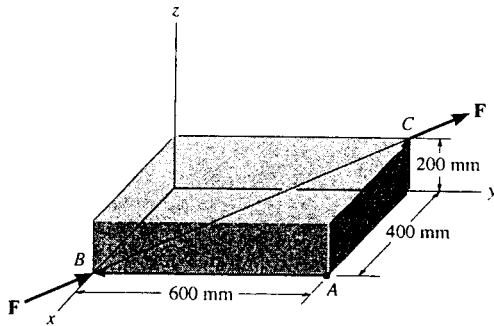

$$\mathbf{F} = 100 \left(\frac{-0.4\mathbf{i} + 0.6\mathbf{j} + 0.2\mathbf{k}}{0.7483} \right)$$

$$\mathbf{F} = \{-53.5\mathbf{i} + 80.2\mathbf{j} + 26.7\mathbf{k}\} \text{ N}$$

$$\mathbf{M}_A = \mathbf{r}_B \times \mathbf{F} = \begin{vmatrix} \mathbf{i} & \mathbf{j} & \mathbf{k} \\ 0 & -0.6 & 0 \\ -53.5 & 80.2 & 26.7 \end{vmatrix} = \{-16.0\mathbf{i} - 32.1\mathbf{k}\} \text{ N} \cdot \text{m} \quad \text{Ans}$$

Also,

$$\mathbf{M}_A = \mathbf{r}_C \times \mathbf{F} = \begin{vmatrix} \mathbf{i} & \mathbf{j} & \mathbf{k} \\ -0.4 & 0 & 0.2 \\ -53.5 & 80.2 & 26.7 \end{vmatrix} = \{-16.0\mathbf{i} - 32.1\mathbf{k}\} \text{ N} \cdot \text{m} \quad \text{Ans}$$

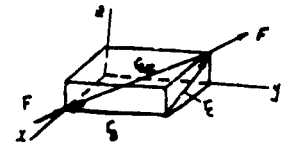

4-43. Determine the smallest force F that must be applied along the rope in order to cause the curved rod, which has a radius of 5 ft, to fail at the support C. This requires a moment of $M = 80 \text{ lb} \cdot \text{ft}$ to be developed at C.

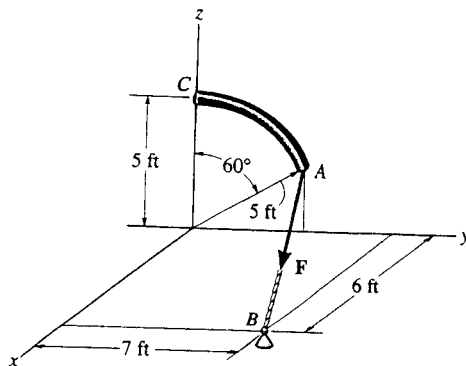

$$\mathbf{r}_{CA} = \{4.330\mathbf{j} - 2.5\mathbf{k}\} \text{ ft}$$

$$\mathbf{F}_{AB} = F_{AB} \left(\frac{6\mathbf{i} + (7-5 \sin 60^\circ)\mathbf{j} - 5 \cos 60^\circ \mathbf{k}}{\sqrt{(6)^2 + (7-5 \sin 60^\circ)^2 + (-5 \cos 60^\circ)^2}} \right)$$

$$\mathbf{F}_{AB} = F_{AB} (0.8538\mathbf{i} + 0.3799\mathbf{j} - 0.3558\mathbf{k})$$

$$\mathbf{M}_C = \mathbf{r}_{CA} \times \mathbf{F}_{AB}$$

$$\mathbf{M}_C = F_{AB} \begin{vmatrix} \mathbf{i} & \mathbf{j} & \mathbf{k} \\ 0 & 4.330 & -2.5 \\ 0.8538 & 0.3799 & -0.3558 \end{vmatrix}$$

$$\mathbf{M}_C = F_{AB} (-0.5909\mathbf{i} + 2.135\mathbf{j} - 3.697\mathbf{k})$$

$$M_C = F_{AB} \sqrt{(-0.5909)^2 + (2.135)^2 + (-3.697)^2}$$

$$80 = F_{AB} (4.310)$$

$$F_{AB} = \frac{80}{4.310} = 18.5618 \text{ lb}$$

$$F_{AB} = 18.6 \text{ lb} \quad \text{Ans}$$

*4-44. The pipe assembly is subjected to the 80-N force. Determine the moment of this force about point A.

Position Vector And Force Vector :

$$\begin{aligned} r_{AC} &= \{(0.55-0)\mathbf{i} + (0.4-0)\mathbf{j} + (-0.2-0)\mathbf{k}\} \text{ m} \\ &= \{0.55\mathbf{i} + 0.4\mathbf{j} - 0.2\mathbf{k}\} \text{ m} \end{aligned}$$

$$\begin{aligned} \mathbf{F} &= 80(\cos 30^\circ \sin 40^\circ \mathbf{i} + \cos 30^\circ \cos 40^\circ \mathbf{j} - \sin 30^\circ \mathbf{k}) \text{ N} \\ &= \{44.53\mathbf{i} + 53.07\mathbf{j} - 40.0\mathbf{k}\} \text{ N} \end{aligned}$$

Moment of Force F About Point A : Applying Eq. 4-7, we have

$$\begin{aligned} \mathbf{M}_A &= r_{AC} \times \mathbf{F} \\ &= \begin{vmatrix} \mathbf{i} & \mathbf{j} & \mathbf{k} \\ 0.55 & 0.4 & -0.2 \\ 44.53 & 53.07 & -40.0 \end{vmatrix} \\ &= \{-5.39\mathbf{i} + 13.1\mathbf{j} + 11.4\mathbf{k}\} \text{ N} \cdot \text{m} \end{aligned}$$

Ans

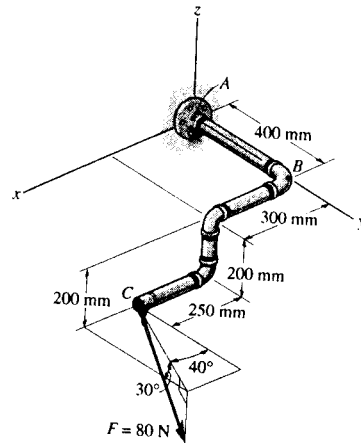

4-45. The pipe assembly is subjected to the 80-N force. Determine the moment of this force about point B.

Position Vector And Force Vector :

$$\begin{aligned} r_{BC} &= \{(0.55-0)\mathbf{i} + (0.4-0.4)\mathbf{j} + (-0.2-0)\mathbf{k}\} \text{ m} \\ &= \{0.55\mathbf{i} - 0.2\mathbf{k}\} \text{ m} \end{aligned}$$

$$\begin{aligned} \mathbf{F} &= 80(\cos 30^\circ \sin 40^\circ \mathbf{i} + \cos 30^\circ \cos 40^\circ \mathbf{j} - \sin 30^\circ \mathbf{k}) \text{ N} \\ &= \{44.53\mathbf{i} + 53.07\mathbf{j} - 40.0\mathbf{k}\} \text{ N} \end{aligned}$$

Moment of Force F About Point B : Applying Eq. 4-7, we have

$$\begin{aligned} \mathbf{M}_B &= r_{BC} \times \mathbf{F} \\ &= \begin{vmatrix} \mathbf{i} & \mathbf{j} & \mathbf{k} \\ 0.55 & 0 & -0.2 \\ 44.53 & 53.07 & -40.0 \end{vmatrix} \\ &= \{10.6\mathbf{i} + 13.1\mathbf{j} + 29.2\mathbf{k}\} \text{ N} \cdot \text{m} \end{aligned}$$

Ans

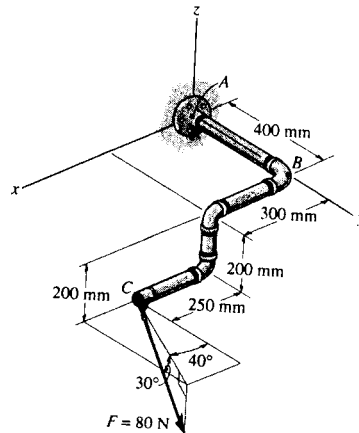

4-46. Strut AB of the 1-m-diameter hatch door exerts a force of 450 N on point B . Determine the moment of this force about point O .

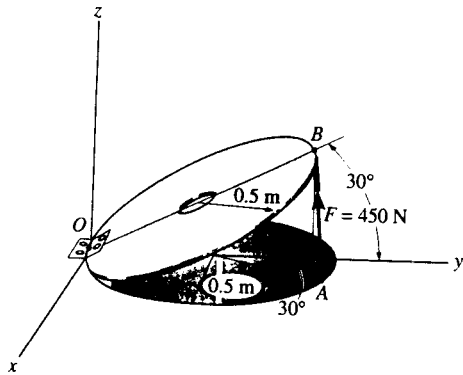

Position Vector And Force Vector :

$$\begin{aligned} \mathbf{r}_{OB} &= \{(0-0)\mathbf{i} + (1\cos 30^\circ - 0)\mathbf{j} + (1\sin 30^\circ - 0)\mathbf{k}\} \text{ m} \\ &= \{0.8660\mathbf{j} + 0.5\mathbf{k}\} \text{ m} \end{aligned}$$

$$\begin{aligned} \mathbf{r}_{OA} &= \{(0.5\sin 30^\circ - 0)\mathbf{i} + (0.5 + 0.5\cos 30^\circ - 0)\mathbf{j} + (0-0)\mathbf{k}\} \text{ m} \\ &= \{0.250\mathbf{i} + 0.9330\mathbf{j}\} \text{ m} \end{aligned}$$

$$\begin{aligned} \mathbf{F} &= 450 \left\{ \frac{(0 - 0.5\sin 30^\circ)\mathbf{i} + [1\cos 30^\circ - (0.5 + 0.5\cos 30^\circ)]\mathbf{j} + (1\sin 30^\circ - 0)\mathbf{k}}{\sqrt{(0 - 0.5\sin 30^\circ)^2 + [1\cos 30^\circ - (0.5 + 0.5\cos 30^\circ)]^2 + (1\sin 30^\circ - 0)^2}} \right\} \text{ N} \\ &= \{-199.82\mathbf{i} - 53.54\mathbf{j} + 399.63\mathbf{k}\} \text{ N} \end{aligned}$$

Moment of Force \mathbf{F} About Point O : Applying Eq. 4-7, we have

$$\begin{aligned} \mathbf{M}_O &= \mathbf{r}_{OB} \times \mathbf{F} \\ &= \begin{vmatrix} \mathbf{i} & \mathbf{j} & \mathbf{k} \\ 0 & 0.8660 & 0.5 \\ -199.82 & -53.54 & 399.63 \end{vmatrix} \\ &= \{373\mathbf{i} - 99.9\mathbf{j} + 173\mathbf{k}\} \text{ N}\cdot\text{m} \quad \text{Ans} \end{aligned}$$

Or

$$\begin{aligned} \mathbf{M}_O &= \mathbf{r}_{OA} \times \mathbf{F} \\ &= \begin{vmatrix} \mathbf{i} & \mathbf{j} & \mathbf{k} \\ 0.250 & 0.9330 & 0 \\ -199.82 & -53.54 & 399.63 \end{vmatrix} \\ &= \{373\mathbf{i} - 99.9\mathbf{j} + 173\mathbf{k}\} \text{ N}\cdot\text{m} \end{aligned}$$

4-47. Using Cartesian vector analysis, determine the resultant moment of the three forces about the base of the column at A . Take $\mathbf{F}_1 = \{400\mathbf{i} + 300\mathbf{j} + 120\mathbf{k}\} \text{ N}$.

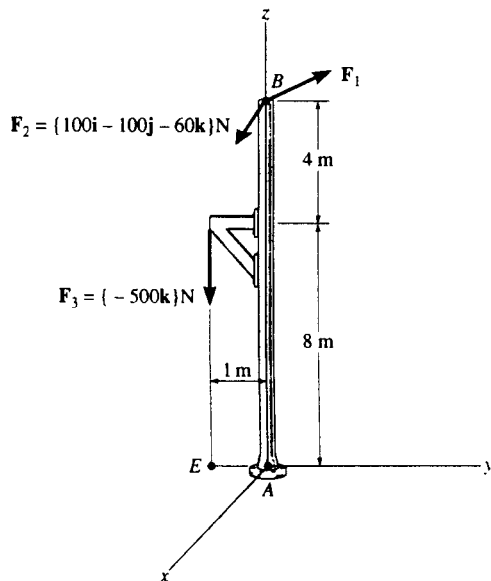

$$(\mathbf{M}_A)_1 = \begin{vmatrix} \mathbf{i} & \mathbf{j} & \mathbf{k} \\ 0 & 0 & 12 \\ 400 & 300 & 120 \end{vmatrix} = \{-3.6\mathbf{i} + 4.8\mathbf{j}\} \text{ kN}\cdot\text{m}$$

$$(\mathbf{M}_A)_2 = \begin{vmatrix} \mathbf{i} & \mathbf{j} & \mathbf{k} \\ 0 & 0 & 12 \\ 100 & -100 & -60 \end{vmatrix} = \{1.2\mathbf{i} + 1.2\mathbf{j}\} \text{ kN}\cdot\text{m}$$

$$(\mathbf{M}_A)_3 = \begin{vmatrix} \mathbf{i} & \mathbf{j} & \mathbf{k} \\ 0 & -1 & 0 \\ 0 & 0 & -500 \end{vmatrix} = \{0.5\mathbf{i}\} \text{ kN}\cdot\text{m}$$

$$M_{Ax} = -3.6 + 1.2 + 0.5 = -1.90 \text{ kN}\cdot\text{m}$$

$$M_{Ay} = 4.8 + 1.2 = 6.00 \text{ kN}\cdot\text{m}$$

$$M_{Az} = 0$$

$$\mathbf{M}_R = \{-1.90\mathbf{i} + 6.00\mathbf{j}\} \text{ kN}\cdot\text{m} \quad \text{Ans}$$

*4-48. A force of $\mathbf{F} = \{6\mathbf{i} - 2\mathbf{j} + 1\mathbf{k}\}$ kN produces a moment of $\mathbf{M}_O = \{4\mathbf{i} + 5\mathbf{j} - 14\mathbf{k}\}$ kN·m about the origin of coordinates, point O . If the force acts at a point having an x coordinate of $x = 1$ m, determine the y and z coordinates.

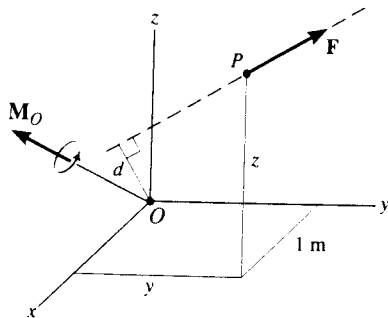

$$\mathbf{M}_O = \mathbf{r} \times \mathbf{F}$$

$$4\mathbf{i} + 5\mathbf{j} - 14\mathbf{k} = \begin{vmatrix} \mathbf{i} & \mathbf{j} & \mathbf{k} \\ 1 & y & z \\ 6 & -2 & 1 \end{vmatrix}$$

$$4 = y + 2z$$

$$5 = -1 + 6z$$

$$-14 = -2 - 6y$$

$$y = 2 \text{ m} \quad \text{Ans}$$

$$z = 1 \text{ m} \quad \text{Ans}$$

4-49. The force $\mathbf{F} = \{6\mathbf{i} + 8\mathbf{j} + 10\mathbf{k}\}$ N creates a moment about point O of $\mathbf{M}_O = \{-14\mathbf{i} + 8\mathbf{j} + 2\mathbf{k}\}$ N·m. If the force passes through a point having an x coordinate of 1 m, determine the y and z coordinates of the point. Also, realizing that $M_O = Fd$, determine the perpendicular distance d from point O to the line of action of \mathbf{F} .

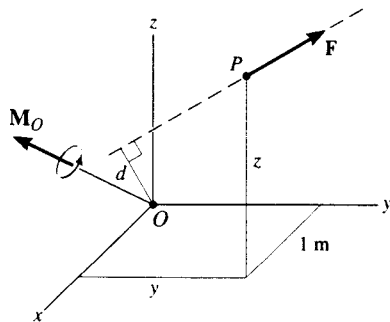

$$-14\mathbf{i} + 8\mathbf{j} + 2\mathbf{k} = \begin{vmatrix} \mathbf{i} & \mathbf{j} & \mathbf{k} \\ 1 & y & z \\ 6 & 8 & 10 \end{vmatrix}$$

$$-14 = 10y - 8z$$

$$8 = -10 + 6z$$

$$2 = 8 - 6y$$

$$y = 1 \text{ m} \quad \text{Ans}$$

$$z = 3 \text{ m} \quad \text{Ans}$$

$$M_O = \sqrt{(-14)^2 + (8)^2 + (2)^2} = 16.25 \text{ N}\cdot\text{m}$$

$$F = \sqrt{(6)^2 + (8)^2 + (10)^2} = 14.14 \text{ N}$$

$$d = \frac{16.25}{14.14} = 1.15 \text{ m} \quad \text{Ans}$$

4-50. Using a ring collar the 75-N force can act in the vertical plane at various angles θ . Determine the magnitude of the moment it produces about point A, plot the result of M (ordinate) versus θ (abscissa) for $0^\circ \leq \theta \leq 180^\circ$, and specify the angles that give the maximum and minimum moment.

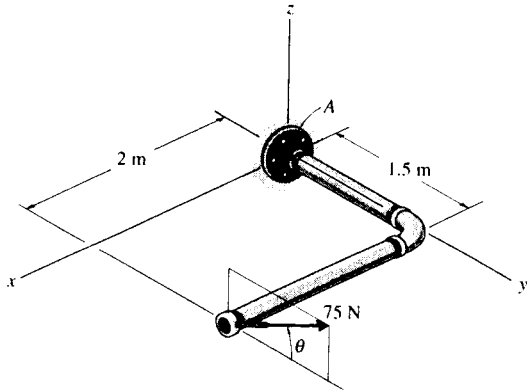

$$\mathbf{M}_A = \begin{vmatrix} \mathbf{i} & \mathbf{j} & \mathbf{k} \\ 2 & 1.5 & 0 \\ 0 & 75 \cos \theta & 75 \sin \theta \end{vmatrix}$$

$$= 112.5 \sin \theta \mathbf{i} - 150 \sin \theta \mathbf{j} + 150 \cos \theta \mathbf{k}$$

$$M_A = \sqrt{(112.5 \sin \theta)^2 + (-150 \sin \theta)^2 + (150 \cos \theta)^2} = \sqrt{12\,656.25 \sin^2 \theta + 22\,500}$$

$$\frac{dM_A}{d\theta} = \frac{1}{2} (12\,656.25 \sin^2 \theta + 22\,500)^{-1/2} (12\,656.25)(2 \sin \theta \cos \theta) = 0$$

$$\sin \theta \cos \theta = 0; \quad \theta = 0^\circ, 90^\circ, 180^\circ \quad \text{Ans}$$

$$M_{\max} = 187.5 \text{ N} \cdot \text{m} \text{ at } \theta = 90^\circ$$

$$M_{\min} = 150 \text{ N} \cdot \text{m} \text{ at } \theta = 0^\circ, 180^\circ$$

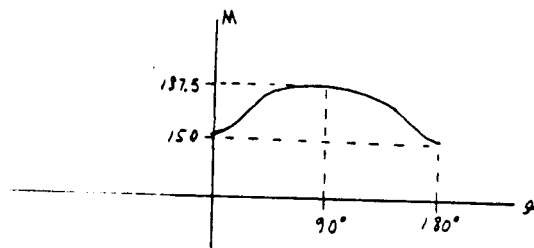

4-51. Determine the moment of the force \mathbf{F} about the Oa axis. Express the result as a Cartesian vector.

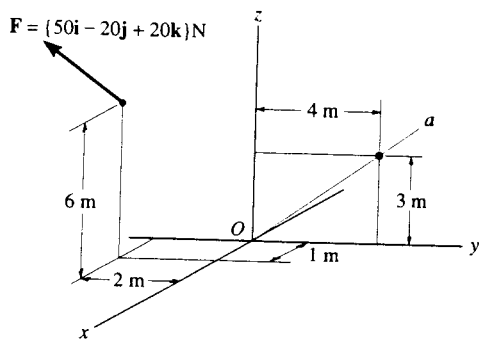

$$\mathbf{u}_{Oa} = \frac{4}{5} \mathbf{j} + \frac{3}{5} \mathbf{k}$$

$$(\mathbf{M}_{Oa})_P = \begin{vmatrix} 0 & \frac{4}{5} & \frac{3}{5} \\ 1 & -2 & 6 \\ 50 & -20 & 20 \end{vmatrix} = 272 \text{ N} \cdot \text{m}$$

$$\begin{aligned} (\mathbf{M}_{Oa})_P &= (\mathbf{M}_{Oa})_P \mathbf{u}_{Oa} \\ &= 272 \left(\frac{4}{5} \mathbf{j} + \frac{3}{5} \mathbf{k} \right) \end{aligned}$$

$$(\mathbf{M}_{Oa})_P = \{ 218\mathbf{j} + 163\mathbf{k} \} \text{ N} \cdot \text{m} \quad \text{Ans}$$

*4-52. Determine the moment of the force F about the aa axis. Express the result as a Cartesian vector.

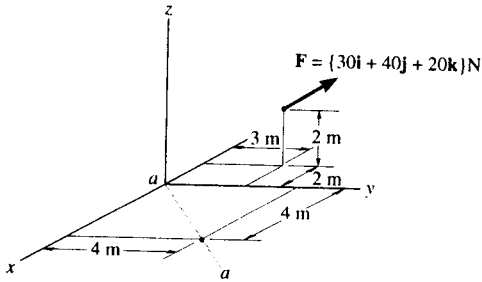

Position Vector :

$$r = \{(-2-0)\mathbf{i} + (3-0)\mathbf{j} + (2-0)\mathbf{k}\} \text{ m} = \{-2\mathbf{i} + 3\mathbf{j} + 2\mathbf{k}\} \text{ m}$$

Unit Vector Along a - a Axis :

$$u_{aa} = \frac{(4-0)\mathbf{i} + (4-0)\mathbf{j}}{\sqrt{(4-0)^2 + (4-0)^2}} = 0.7071\mathbf{i} + 0.7071\mathbf{j}$$

Moment of Force F About a - a Axis : With $F = \{30\mathbf{i} + 40\mathbf{j} + 20\mathbf{k}\} \text{ N}$, applying Eq. 4-11, we have

$$\begin{aligned} M_{aa} &= u_{aa} \cdot (r \times F) \\ &= \begin{vmatrix} 0.7071 & 0.7071 & 0 \\ -2 & 3 & 2 \\ 30 & 40 & 20 \end{vmatrix} \\ &= 0.7071[3(20) - 40(2)] - 0.7071[(-2)(20) - 30(2)] + 0 \\ &= 56.6 \text{ N} \cdot \text{m} \end{aligned}$$

Ans

4-53. Determine the resultant moment of the two forces about the Oa axis. Express the result as a Cartesian vector.

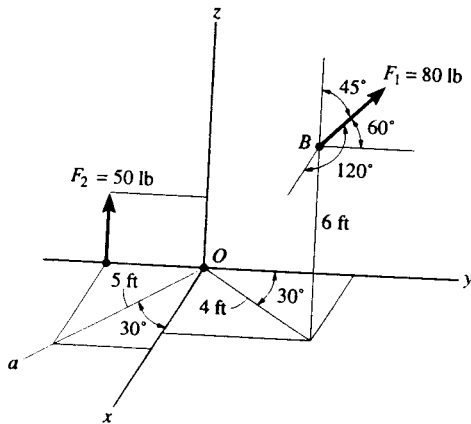

$$F_1 = 80(\cos 120^\circ \mathbf{i} + \cos 60^\circ \mathbf{j} + \cos 45^\circ \mathbf{k}) = \{-40\mathbf{i} + 40\mathbf{j} + 56.569\mathbf{k}\} \text{ lb}$$

$$F_2 = \{50\mathbf{k}\} \text{ lb}$$

$$\begin{aligned} r_1 &= (4 \sin 30^\circ - 0)\mathbf{i} + (4 \cos 30^\circ - 0)\mathbf{j} + (6 - 0)\mathbf{k} \\ &= \{2\mathbf{i} + 3.464\mathbf{j} + 6\mathbf{k}\} \text{ ft} \end{aligned}$$

$$r_2 = (-5 \sin 30^\circ)\mathbf{j} = \{-2.5\mathbf{j}\} \text{ ft}$$

$$M_R = r_1 \times F_1 + r_2 \times F_2$$

$$= \begin{vmatrix} \mathbf{i} & \mathbf{j} & \mathbf{k} \\ 2 & 3.464 & 6 \\ -40 & 40 & 56.569 \end{vmatrix} + (-2.5\mathbf{j}) \times (50\mathbf{k})$$

$$\begin{aligned} &= [3.464(56.569) - 40(6)]\mathbf{i} - [2(56.569) - (-40)(6)]\mathbf{j} + [2(40) - (-40)(3.464)]\mathbf{k} - 125\mathbf{i} \\ &= \{-169.044\mathbf{i} - 353.138\mathbf{j} + 218.560\mathbf{k}\} \text{ lb} \cdot \text{ft} \end{aligned}$$

$$u_{Oa} = \cos 30^\circ \mathbf{i} - \sin 30^\circ \mathbf{j} = 0.8660\mathbf{i} - 0.5\mathbf{j}$$

$$(M_R)_{Oa} = u_{Oa} \cdot M_R = (0.8660\mathbf{i} - 0.5\mathbf{j}) \cdot (-169.044\mathbf{i} - 353.138\mathbf{j} + 218.560\mathbf{k})$$

$$= (0.8660)(-169.044) + (-0.5)(-353.138) + 0(218.560)$$

$$= 30.173 \text{ lb} \cdot \text{ft}$$

$$(M_R)_{Oa} = (M_R)_{Oa} u_{Oa} = 30.173(0.8660\mathbf{i} - 0.5\mathbf{j})$$

$$= \{26.1\mathbf{i} - 15.1\mathbf{j}\} \text{ lb} \cdot \text{ft}$$

Ans

***4-52.** Determine the moment of the force F about the aa axis. Express the result as a Cartesian vector.

Position Vector:

$$\mathbf{r} = [(-2 - 0)\mathbf{i} + (3 - 0)\mathbf{j} + (2 - 0)\mathbf{k}] \text{ m} = \{-2\mathbf{i} + 3\mathbf{j} + 2\mathbf{k}\} \text{ m}$$

Unit Vector Along $a - a$ Axis:

$$\mathbf{u}_{aa} = \frac{(4 - 0)\mathbf{i} + (4 - 0)\mathbf{j}}{\sqrt{(4 - 0)^2 + (4 - 0)^2}} = 0.7071\mathbf{i} + 0.7071\mathbf{j}$$

Moment of Force F About $a - a$ Axis: With $\mathbf{F} = \{30\mathbf{i} + 40\mathbf{j} + 20\mathbf{k}\}$ N, applying Eq. 4-11, we have

$$M_{aa} = \mathbf{u}_{aa} \cdot (\mathbf{r} \times \mathbf{F})$$

$$= \begin{vmatrix} 0.7071 & 0.7071 & 0 \\ -2 & 3 & 2 \\ 30 & 40 & 20 \end{vmatrix}$$

$$= 0.7071[3(20) - 40(2)] - 0.7071[(-2)(20) - 30(2)] + 0$$

$$= 56.6 \text{ N} \cdot \text{m} \quad \text{Ans}$$

$$\mathbf{M}_{aa} = M_{aa}\mathbf{u}_{aa}$$

$$= 56.57(0.7071\mathbf{i} + 0.7071\mathbf{j})$$

$$= \{40\mathbf{i} + 40\mathbf{j}\} \text{ N} \cdot \text{m} \quad \text{Ans}$$

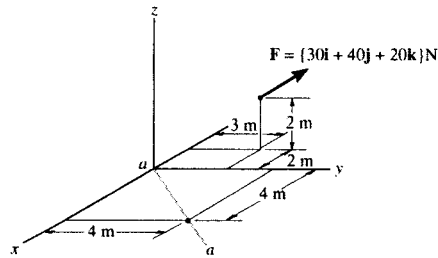

4-53. Determine the resultant moment of the two forces about the Oa axis. Express the result as a Cartesian vector.

$$\mathbf{F}_1 = 80(\cos 120^\circ\mathbf{i} + \cos 60^\circ\mathbf{j} + \cos 45^\circ\mathbf{k}) = \{-40\mathbf{i} + 40\mathbf{j} + 56.569\mathbf{k}\} \text{ lb}$$

$$\mathbf{F}_2 = \{50\mathbf{k}\} \text{ lb}$$

$$\mathbf{r}_1 = (4 \sin 30^\circ - 0)\mathbf{i} + (4 \cos 30^\circ - 0)\mathbf{j} + (6 - 0)\mathbf{k}$$

$$= \{2\mathbf{i} + 3.464\mathbf{j} + 6\mathbf{k}\} \text{ ft}$$

$$\mathbf{r}_2 = (-5 \sin 30^\circ)\mathbf{j} = \{-2.5\mathbf{j}\} \text{ ft}$$

$$\mathbf{M}_R = \mathbf{r}_1 \times \mathbf{F}_1 + \mathbf{r}_2 \times \mathbf{F}_2$$

$$= \begin{vmatrix} \mathbf{i} & \mathbf{j} & \mathbf{k} \\ 2 & 3.464 & 6 \\ -40 & 40 & 56.569 \end{vmatrix} + (-2.5\mathbf{j}) \times (50\mathbf{k})$$

$$= [3.464(56.569) - 40(6)]\mathbf{i} - [2(56.569) - (-40)(6)]\mathbf{j} + [2(40) - (-40)(3.464)]\mathbf{k} - 125\mathbf{i}$$

$$= \{-169.044\mathbf{i} - 353.138\mathbf{j} + 218.560\mathbf{k}\} \text{ lb} \cdot \text{ft}$$

$$\mathbf{u}_{Oa} = \cos 30^\circ\mathbf{i} - \sin 30^\circ\mathbf{j} = 0.8660\mathbf{i} - 0.5\mathbf{j}$$

$$(\mathbf{M}_R)_{Oa} = \mathbf{u}_{Oa} \cdot \mathbf{M}_R = (0.8660\mathbf{i} - 0.5\mathbf{j}) \cdot (-169.044\mathbf{i} - 353.138\mathbf{j} + 218.560\mathbf{k})$$

$$= (0.8660)(-169.044) + (-0.5)(-353.138) + 0(218.560)$$

$$= 30.173 \text{ lb} \cdot \text{ft}$$

$$(\mathbf{M}_R)_{Oa} = (\mathbf{M}_R)_{Oa}\mathbf{u}_{Oa} = 30.173(0.8660\mathbf{i} - 0.5\mathbf{j})$$

$$= \{26.1\mathbf{i} - 15.1\mathbf{j}\} \text{ lb} \cdot \text{ft} \quad \text{Ans}$$

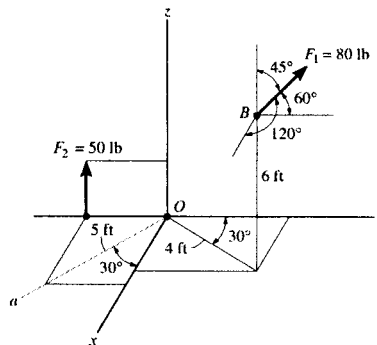

4-54. Determine the magnitude of the moment of each of the three forces about the axis AB . Solve the problem (a) using a Cartesian vector approach and (b) using a scalar approach.

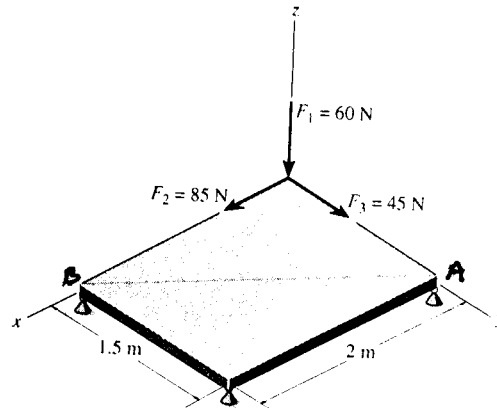

a) Vector Analysis

Position Vector and Force Vector :

$$\begin{aligned} \mathbf{r}_1 &= \{-1.5\mathbf{j}\} \text{ m} & \mathbf{r}_2 &= \mathbf{r}_3 = \mathbf{0} \\ \mathbf{F}_1 &= \{-60\mathbf{k}\} \text{ N} & \mathbf{F}_2 &= \{85\mathbf{i}\} \text{ N} & \mathbf{F}_3 &= \{45\mathbf{j}\} \text{ N} \end{aligned}$$

Unit Vector Along AB Axis :

$$\mathbf{u}_{AB} = \frac{(2-0)\mathbf{i} + (0-1.5)\mathbf{j}}{\sqrt{(2-0)^2 + (0-1.5)^2}} = 0.8\mathbf{i} - 0.6\mathbf{j}$$

Moment of Each Force About AB Axis : Applying Eq. 4-11, we have

$$(M_{AB})_1 = \mathbf{u}_{AB} \cdot (\mathbf{r}_1 \times \mathbf{F}_1)$$

$$= \begin{vmatrix} 0.8 & -0.6 & 0 \\ 0 & -1.5 & 0 \\ 0 & 0 & -60 \end{vmatrix}$$

$$= 0.8[(-1.5)(-60) - 0] - 0 + 0 = 72.0 \text{ N} \cdot \text{m} \quad \text{Ans}$$

$$(M_{AB})_2 = \mathbf{u}_{AB} \cdot (\mathbf{r}_2 \times \mathbf{F}_2)$$

$$= \begin{vmatrix} 0.8 & -0.6 & 0 \\ 0 & 0 & 0 \\ 85 & 0 & 0 \end{vmatrix} = 0 \quad \text{Ans}$$

$$(M_{AB})_3 = \mathbf{u}_{AB} \cdot (\mathbf{r}_3 \times \mathbf{F}_3)$$

$$= \begin{vmatrix} 0.8 & -0.6 & 0 \\ 0 & 0 & 0 \\ 0 & 45 & 0 \end{vmatrix} = 0 \quad \text{Ans}$$

b) Scalar Analysis : Since moment arm from force F_2 and F_3 is equal to zero, Hence

$$(M_{AB})_2 = (M_{AB})_3 = 0 \quad \text{Ans}$$

Moment arm d from force F_1 to axis AB is $d = 1.5 \sin 53.13^\circ = 1.20 \text{ m}$, Hence

$$(M_{AB})_1 = F_1 d = 60(1.20) = 72.0 \text{ N} \cdot \text{m} \quad \text{Ans}$$

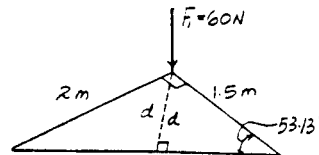

4-55. The chain AB exerts a force of 20 lb on the door at B . Determine the magnitude of the moment of this force along the hinged axis x of the door.

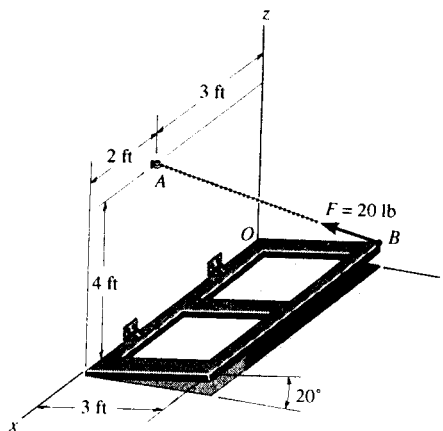

Position Vector and Force Vector :

$$\begin{aligned} \mathbf{r}_{OA} &= \{(3-0)\mathbf{i} + (4-0)\mathbf{k}\} \text{ ft} = \{3\mathbf{i} + 4\mathbf{k}\} \text{ ft} \\ \mathbf{r}_{OB} &= \{(0-0)\mathbf{i} + (3\cos 20^\circ - 0)\mathbf{j} + (3\sin 20^\circ - 0)\mathbf{k}\} \text{ ft} \\ &= \{2.8191\mathbf{j} + 1.0261\mathbf{k}\} \text{ ft} \end{aligned}$$

$$\begin{aligned} \mathbf{F} &= 20 \left(\frac{(3-0)\mathbf{i} + (0-3\cos 20^\circ)\mathbf{j} + (4-3\sin 20^\circ)\mathbf{k}}{\sqrt{(3-0)^2 + (0-3\cos 20^\circ)^2 + (4-3\sin 20^\circ)^2}} \right) \text{ lb} \\ &= \{11.814\mathbf{i} - 11.102\mathbf{j} + 11.712\mathbf{k}\} \text{ lb} \end{aligned}$$

Moment of Force \mathbf{F} About x Axis : The unit vector along the x axis is \mathbf{i} . Applying Eq. 4-11, we have

$$\begin{aligned} M_x &= \mathbf{i} \cdot (\mathbf{r}_{OA} \times \mathbf{F}) \\ &= \begin{vmatrix} 1 & 0 & 0 \\ 3 & 0 & 4 \\ 11.814 & -11.102 & 11.712 \end{vmatrix} \end{aligned}$$

$$\begin{aligned} &= 1[0(11.712) - (-11.102)(4)] - 0 + 0 \\ &= 44.4 \text{ lb}\cdot\text{ft} \end{aligned}$$

Ans

Or

$$\begin{aligned} M_x &= \mathbf{i} \cdot (\mathbf{r}_{OB} \times \mathbf{F}) \\ &= \begin{vmatrix} 1 & 0 & 0 \\ 0 & 2.8191 & 1.0261 \\ 11.814 & -11.102 & 11.712 \end{vmatrix} \\ &= 1[2.8191(11.712) - (-11.102)(1.0261)] - 0 + 0 \\ &= 44.4 \text{ lb}\cdot\text{ft} \end{aligned}$$

***4-56.** The force of $F = 30 \text{ N}$ acts on the bracket as shown. Determine the moment of the force about the a - a axis of the pipe. Also, determine the coordinate direction angles of F in order to produce the maximum moment about the a - a axis. What is this moment?

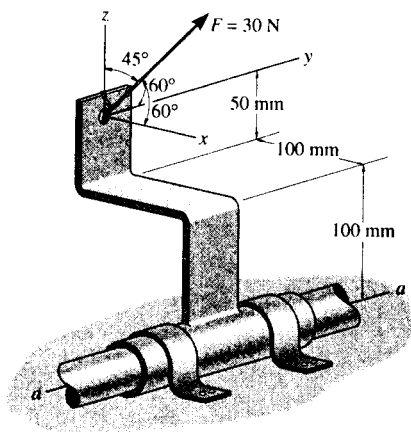

$$\mathbf{F} = 30 (\cos 60^\circ \mathbf{i} + \cos 60^\circ \mathbf{j} + \cos 45^\circ \mathbf{k})$$

$$= (15 \mathbf{i} + 15 \mathbf{j} + 21.21 \mathbf{k}) \text{ N}$$

$$\mathbf{r} = (-0.1 \mathbf{i} + 0.15 \mathbf{k}) \text{ m}$$

$$\mathbf{u} = \mathbf{j}$$

$$M_a = \begin{vmatrix} 0 & 1 & 0 \\ -0.1 & 0 & 0.15 \\ 15 & 15 & 21.21 \end{vmatrix} = 4.37 \text{ N} \cdot \text{m} \quad \text{Ans}$$

\mathbf{F} must be perpendicular to \mathbf{u} and \mathbf{r} .

$$\mathbf{u}_r = \frac{0.15}{0.1803} \mathbf{i} + \frac{0.1}{0.1803} \mathbf{k}$$

$$= 0.8321 \mathbf{i} + 0.5547 \mathbf{k}$$

$$\alpha = \cos^{-1} 0.8321 = 33.7^\circ \quad \text{Ans}$$

$$\beta = \cos^{-1} 0 = 90^\circ \quad \text{Ans}$$

$$\gamma = \cos^{-1} 0.5547 = 56.3^\circ \quad \text{Ans}$$

$$M = 30 (0.1803) = 5.41 \text{ N} \cdot \text{m} \quad \text{Ans}$$

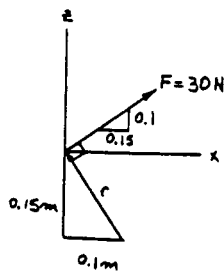

4-57. The cutting tool on the lathe exerts a force F on the shaft in the direction shown. Determine the moment of this force about the y axis of the shaft.

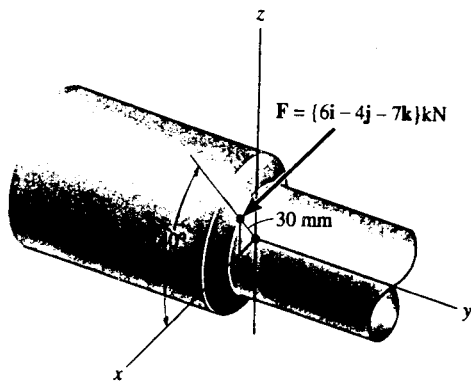

$$M_y = \mathbf{u}_y \cdot (\mathbf{r} \times \mathbf{F})$$

$$= \begin{vmatrix} 0 & 1 & 0 \\ 0.03 \cos 40^\circ & 0 & 0.03 \sin 40^\circ \\ 6 & -4 & -7 \end{vmatrix}$$

$$M_y = 276.57 \text{ N}\cdot\text{mm} = 0.277 \text{ N}\cdot\text{m} \quad \text{Ans}$$

4-58. The hood of the automobile is supported by the strut AB , which exerts a force of $F = 24 \text{ lb}$ on the hood. Determine the moment of this force about the hinged axis y .

$$\mathbf{r} = \{4\mathbf{i}\} \text{ m}$$

$$\mathbf{F} = 24 \left(\frac{-2\mathbf{i} + 2\mathbf{j} + 4\mathbf{k}}{\sqrt{(-2)^2 + (2)^2 + (4)^2}} \right)$$

$$= \{-9.80\mathbf{i} + 9.80\mathbf{j} + 19.60\mathbf{k}\} \text{ lb}$$

$$M_y = \begin{vmatrix} 0 & 1 & 0 \\ 4 & 0 & 0 \\ -9.80 & 9.80 & 19.60 \end{vmatrix} = -78.4 \text{ lb}\cdot\text{ft}$$

$$M_y = \{-78.4\mathbf{j}\} \text{ lb}\cdot\text{ft} \quad \text{Ans}$$

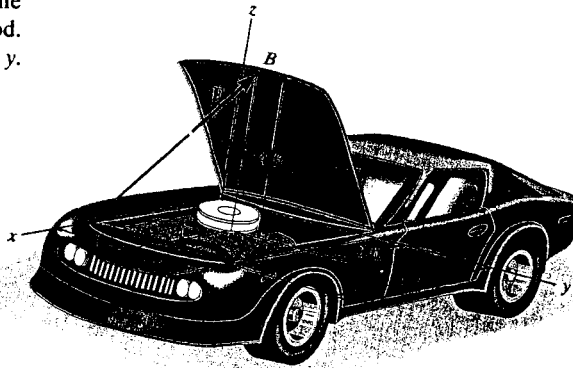

4-59. Determine the magnitude of the moments of the force F about the x , y , and z axes. Solve the problem (a) using a Cartesian vector approach and (b) using a scalar approach.

a) **Vector Analysis**

Position Vector :

$$\mathbf{r}_{AB} = \{(4-0)\mathbf{i} + (3-0)\mathbf{j} + (-2-0)\mathbf{k}\} \text{ ft} = \{4\mathbf{i} + 3\mathbf{j} - 2\mathbf{k}\} \text{ ft}$$

Moment of Force F About x , y and z Axes : The unit vectors along x , y and z axes are \mathbf{i} , \mathbf{j} and \mathbf{k} respectively. Applying Eq. 4-11, we have

$$M_x = \mathbf{i} \cdot (\mathbf{r}_{AB} \times \mathbf{F})$$

$$= \begin{vmatrix} 1 & 0 & 0 \\ 4 & 3 & -2 \\ 4 & 12 & -3 \end{vmatrix}$$

$$= 1[3(-3) - (12)(-2)] - 0 + 0 = 15.0 \text{ lb}\cdot\text{ft} \quad \text{Ans}$$

$$M_y = \mathbf{j} \cdot (\mathbf{r}_{AB} \times \mathbf{F})$$

$$= \begin{vmatrix} 0 & 1 & 0 \\ 4 & 3 & -2 \\ 4 & 12 & -3 \end{vmatrix}$$

$$= 0 - 1[4(-3) - (4)(-2)] + 0 = 4.00 \text{ lb}\cdot\text{ft} \quad \text{Ans}$$

$$M_z = \mathbf{k} \cdot (\mathbf{r}_{AB} \times \mathbf{F})$$

$$= \begin{vmatrix} 0 & 0 & 1 \\ 4 & 3 & -2 \\ 4 & 12 & -3 \end{vmatrix}$$

$$= 0 - 0 + 1[4(12) - 4(3)] = 36.0 \text{ lb}\cdot\text{ft} \quad \text{Ans}$$

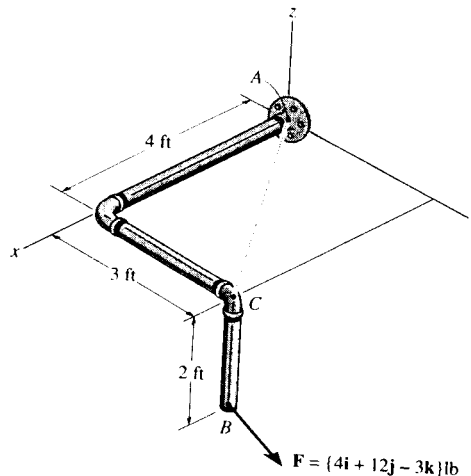

b) **Scalar Analysis**

$$M_x = \Sigma M_x; \quad M_x = 12(2) - 3(3) = 15.0 \text{ lb}\cdot\text{ft} \quad \text{Ans}$$

$$M_y = \Sigma M_y; \quad M_y = -4(2) + 3(4) = 4.00 \text{ lb}\cdot\text{ft} \quad \text{Ans}$$

$$M_z = \Sigma M_z; \quad M_z = -4(3) + 12(4) = 36.0 \text{ lb}\cdot\text{ft} \quad \text{Ans}$$

***4-60.** Determine the moment of the force \mathbf{F} about an axis extending between A and C . Express the result as a Cartesian vector.

Position Vector :

$$\mathbf{r}_{CB} = \{-2\mathbf{k}\} \text{ ft}$$

$$\mathbf{r}_{AB} = \{(4-0)\mathbf{i} + (3-0)\mathbf{j} + (-2-0)\mathbf{k}\} \text{ ft} = \{4\mathbf{i} + 3\mathbf{j} - 2\mathbf{k}\} \text{ ft}$$

Unit Vector Along AC Axis :

$$\mathbf{u}_{AC} = \frac{(4-0)\mathbf{i} + (3-0)\mathbf{j}}{\sqrt{(4-0)^2 + (3-0)^2}} = 0.8\mathbf{i} + 0.6\mathbf{j}$$

Moment of Force \mathbf{F} About AC Axis : With $\mathbf{F} = \{4\mathbf{i} + 12\mathbf{j} - 3\mathbf{k}\}$ lb, applying Eq. 4-11, we have

$$M_{AC} = \mathbf{u}_{AC} \cdot (\mathbf{r}_{CB} \times \mathbf{F})$$

$$\begin{aligned} &= \begin{vmatrix} 0.8 & 0.6 & 0 \\ 0 & 0 & -2 \\ 4 & 12 & -3 \end{vmatrix} \\ &= 0.8[(0)(-3) - 12(-2)] - 0.6[0(-3) - 4(-2)] + 0 \\ &= 14.4 \text{ lb} \cdot \text{ft} \end{aligned}$$

Or

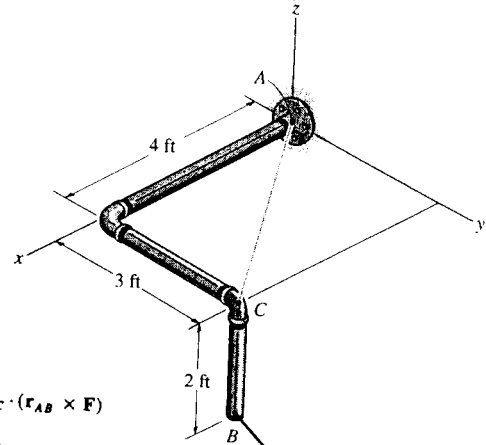

$$M_{AC} = \mathbf{u}_{AC} \cdot (\mathbf{r}_{AB} \times \mathbf{F})$$

$$\begin{aligned} &= \begin{vmatrix} 0.8 & 0.6 & 0 \\ 4 & 3 & -2 \\ 4 & 12 & -3 \end{vmatrix} \\ &= 0.8[(3)(-3) - 12(-2)] - 0.6[4(-3) - 4(-2)] + 0 \\ &= 14.4 \text{ lb} \cdot \text{ft} \end{aligned}$$

Expressing M_{AC} as a Cartesian vector yields

$$\begin{aligned} M_{AC} &= M_{AC} \mathbf{u}_{AC} \\ &= 14.4(0.8\mathbf{i} + 0.6\mathbf{j}) \\ &= \{11.5\mathbf{i} + 8.64\mathbf{j}\} \text{ lb} \cdot \text{ft} \end{aligned}$$

Ans

4-61. The lug and box wrenches are used in combination to remove the lug nut from the wheel hub. If the applied force on the end of the box wrench is $\mathbf{F} = \{4\mathbf{i} - 12\mathbf{j} + 2\mathbf{k}\}$ N, determine the magnitude of the moment of this force about the x axis which is effective in unscrewing the lug nut.

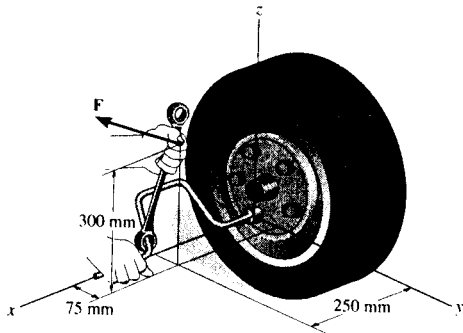

Position Vector and Force Vector :

$$\mathbf{r} = \{(0.075-0)\mathbf{j} + (0.3-0)\mathbf{k}\} \text{ m} = \{0.075\mathbf{j} + 0.3\mathbf{k}\} \text{ m}$$

Moment of Force \mathbf{F} About x Axis : The unit vector along x axis is \mathbf{i} . With $\mathbf{F} = \{4\mathbf{i} - 12\mathbf{j} + 2\mathbf{k}\}$ N, applying Eq. 4-11, we have

$$M_x = \mathbf{i} \cdot (\mathbf{r} \times \mathbf{F})$$

$$\begin{aligned} &= \begin{vmatrix} 1 & 0 & 0 \\ 0 & 0.075 & 0.3 \\ 4 & -12 & 2 \end{vmatrix} \\ &= 1[0.075(2) - (-12)(0.3)] - 0 + 0 \\ &= 3.75 \text{ N} \cdot \text{m} \end{aligned}$$

Ans

4-62. A 70-lb force acts vertically on the "Z" bracket. Determine the magnitude of the moment of this force about the bolt axis (z axis).

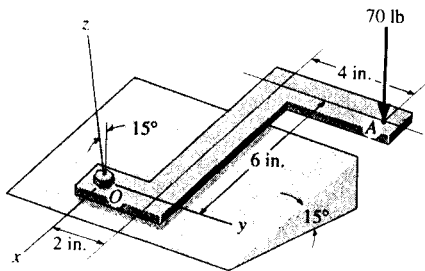

Position Vector And Force Vector :

$$r_{OA} = \{(-6-0)\mathbf{i} + (6-0)\mathbf{j}\} \text{ in.} = \{-6\mathbf{i} + 6\mathbf{j}\} \text{ in.}$$

$$F = 70(\sin 15^\circ\mathbf{i} - \cos 15^\circ\mathbf{k}) \text{ lb} = \{18.117\mathbf{i} - 67.615\mathbf{k}\} \text{ lb}$$

Moment of Force F About z Axis : The unit vector along z axis is \mathbf{k} . Applying Eq. 4-11, we have

$$\begin{aligned} M_z &= \mathbf{k} \cdot (r_{OA} \times F) \\ &= \begin{vmatrix} 0 & 0 & 1 \\ -6 & 6 & 0 \\ 18.117 & 0 & -67.615 \end{vmatrix} \\ &= 0 - 0 + 1[(-6)(0) - (6)(18.117)] \\ &= -109 \text{ lb} \cdot \text{in} \end{aligned}$$

Negative sign indicates that M_z is directed toward negative z axis.
 $M_z = 109 \text{ lb} \cdot \text{in}$

4-63. Determine the magnitude of the moment of the force $F = \{50\mathbf{i} - 20\mathbf{j} - 80\mathbf{k}\} \text{ N}$ about the base line CA of the tripod.

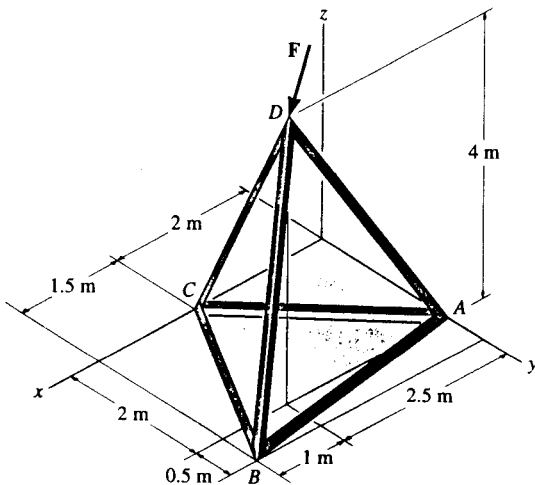

$$u_{CA} = \frac{\{-2\mathbf{i} + 2\mathbf{j}\}}{\sqrt{(-2)^2 + (2)^2}}$$

$$u_{CA} = \{-0.707\mathbf{i} + 0.707\mathbf{j}\}$$

$$M_{CA} = u_{CA} \cdot (r_{AD} \times F) = \begin{vmatrix} -0.707 & 0.707 & 0 \\ 2.5 & 0 & 4 \\ 50 & -20 & -80 \end{vmatrix}$$

$$|M_{CA}| = 226 \text{ N} \cdot \text{m} \quad \text{Ans}$$

*4-64. The flex-headed ratchet wrench is subjected to a force of $P = 16 \text{ lb}$, applied perpendicular to the handle as shown. Determine the moment or torque this imparts along the vertical axis of the bolt at A.

$$M = 16(0.75 + 10\sin 60^\circ)$$

$$M = 151 \text{ lb} \cdot \text{in.} \quad \text{Ans}$$

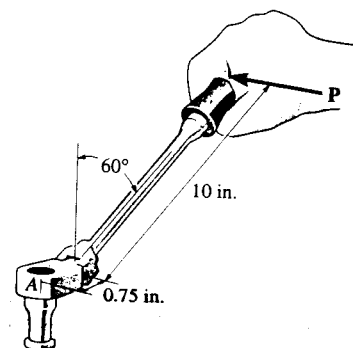

4-65. If a torque or moment of 80 lb · in is required to looser the bolt at A, determine the force P that must be applied perpendicular to the handle of the flex-headed ratchet wrench.

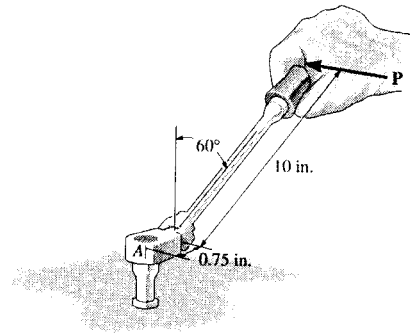

$$80 = P(0.75 + 10 \sin 60^\circ)$$

$$P = \frac{80}{9.41} = 8.50 \text{ lb} \quad \text{Ans}$$

4-66. The A-frame is being hoisted into an upright position by the vertical force of $F = 80 \text{ lb}$. Determine the moment of this force about the y axis when the frame is in the position shown.

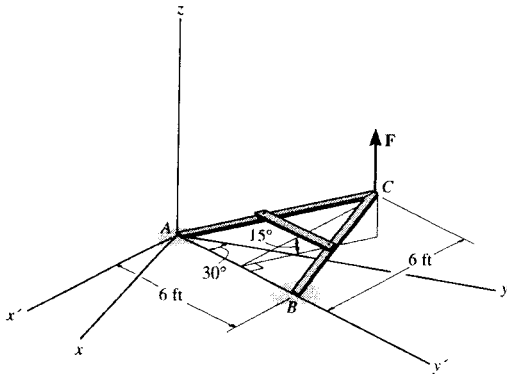

Using x', y', z :

$$u_y = -\sin 30^\circ i' + \cos 30^\circ j'$$

$$r_{AC} = -6 \cos 15^\circ i' + 3j' + 6 \sin 15^\circ k$$

$$F = 80k$$

$$M_y = \begin{vmatrix} -\sin 30^\circ & \cos 30^\circ & 0 \\ -6 \cos 15^\circ & 3 & 6 \sin 15^\circ \\ 0 & 0 & 80 \end{vmatrix} = -120 + 401.52 + 0$$

$$M_y = 282 \text{ lb} \cdot \text{ft} \quad \text{Ans}$$

Also, using x, y, z :

Coordinates of point C:

$$x = 3 \sin 30^\circ - 6 \cos 15^\circ \cos 30^\circ = -3.52 \text{ ft}$$

$$y = 3 \cos 30^\circ + 6 \cos 15^\circ \sin 30^\circ = 5.50 \text{ ft}$$

$$z = 6 \sin 15^\circ = 1.55 \text{ ft}$$

$$r_{AC} = -3.52i + 5.50j + 1.55k$$

$$F = 80k$$

$$M_y = \begin{vmatrix} 0 & 1 & 0 \\ -3.52 & 5.50 & 1.55 \\ 0 & 0 & 80 \end{vmatrix} = 282 \text{ lb} \cdot \text{ft} \quad \text{Ans}$$

4-67. A horizontal force of $F = \{-50i\} \text{ N}$ is applied perpendicular to the handle of the pipe wrench. Determine the moment that this force exerts along the axis OA (z axis) of the pipe assembly. Both the wrench and pipe assembly OABC lie in the y - z plane. Suggestion: Use a scalar analysis.

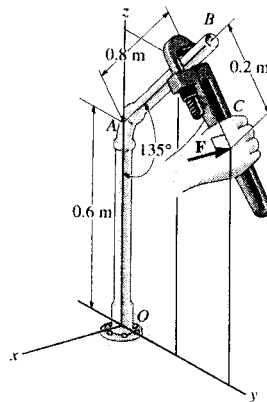

$$M_z = 50(0.8 + 0.2) \cos 45^\circ = 35.36 \text{ N} \cdot \text{m}$$

$$M_z = \{35.4k\} \text{ N} \cdot \text{m} \quad \text{Ans}$$

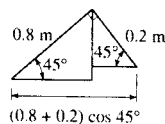

***4-68.** Determine the magnitude of the horizontal force $\mathbf{F} = -F\mathbf{i}$ acting on the handle of the wrench so that this force produces a component of moment along the OA axis (z axis) of the pipe assembly of $M_z = \{4\mathbf{k}\}\text{N}\cdot\text{m}$. Both the wrench and the pipe assembly, $OABC$, lie in the $y-z$ plane. *Suggestion:* Use a scalar analysis.

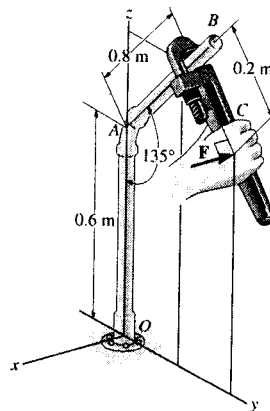

$$M_z = F(0.8 + 0.2) \cos 45^\circ = 4$$

$$F = 5.66 \text{ N} \quad \text{Ans}$$

4-69. Determine the magnitude and sense of the couple moment.

About point A ,

$$\curvearrowleft +M_C = 5 \cos 30^\circ(2.5) + 5 \sin 30^\circ(3)$$

$$M_C = 18.3 \text{ kN}\cdot\text{m} \quad \curvearrowright \quad \text{Ans}$$

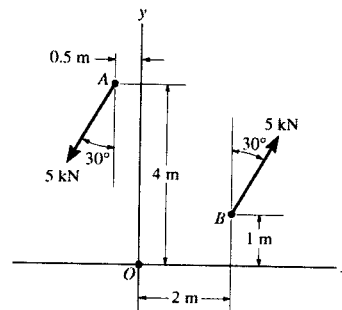

4-70. Determine the magnitude and sense of the couple moment. Each force has a magnitude of $F = 65 \text{ lb}$.

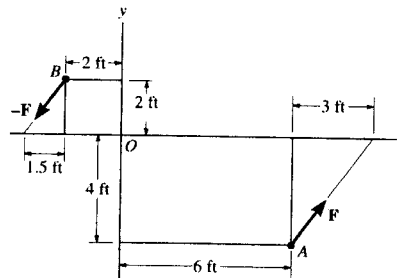

$$\begin{aligned} \curvearrowleft +M_C = \Sigma M_B: \quad M_C &= 65 \left(\frac{4}{5}\right)(6+2) + 65 \left(\frac{3}{5}\right)(4+2) \\ &= 650 \text{ lb}\cdot\text{ft} \quad (\text{Counterclockwise}) \quad \text{Ans} \end{aligned}$$

4-71. Determine the magnitude and sense of the couple moment. Each force has a magnitude of $F = 8 \text{ kN}$.

$$\begin{aligned} \curvearrowleft +M_C = \Sigma M_B: \quad M_C &= 8 \left(\frac{3}{5}\right)(5+4) - 8 \left(\frac{4}{5}\right)(3+1) \\ &= 17.6 \text{ kN}\cdot\text{m} \quad (\text{Counterclockwise}) \quad \text{Ans} \end{aligned}$$

*4-72. If the couple moment has a magnitude of $300 \text{ lb} \cdot \text{ft}$, determine the magnitude F of the couple forces.

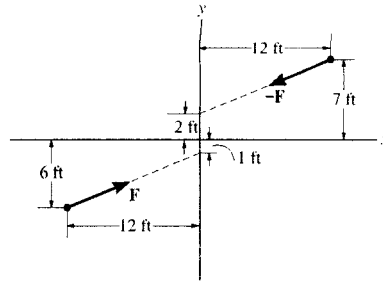

$$300 = F \left(\frac{12}{13} \right) (13) - F \left(\frac{5}{13} \right) (24)$$

$$F = 108 \text{ lb}$$

Ans

4-73. A twist of $4 \text{ N} \cdot \text{m}$ is applied to the handle of the screwdriver. Resolve this couple moment into a pair of couple forces F exerted on the handle and P exerted on the blade.

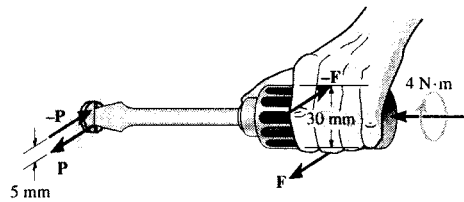

For the handle

$$M_C = \Sigma M_x; \quad F(0.03) = 4$$

$$F = 133 \text{ N}$$

Ans

For the blade,

$$M_C = \Sigma M_x; \quad P(0.005) = 4$$

$$P = 800 \text{ N}$$

Ans

4-74. The resultant couple moment created by the two couples acting on the disk is $\mathbf{M}_R = \{10\mathbf{k}\} \text{ kip} \cdot \text{in}$. Determine the magnitude of force T .

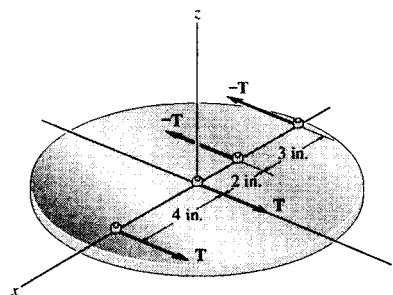

$$M_R = \Sigma M_z; \quad 10 = T(9) + T(2)$$

$$T = 0.909 \text{ kip}$$

Ans

4-75. A device called a rolamite is used in various ways to replace slipping motion with rolling motion. If the belt, which wraps between the rollers, is subjected to a tension of 15 N, determine the reactive forces N of the top and bottom plates on the rollers so that the resultant couple acting on the rollers is equal to zero.

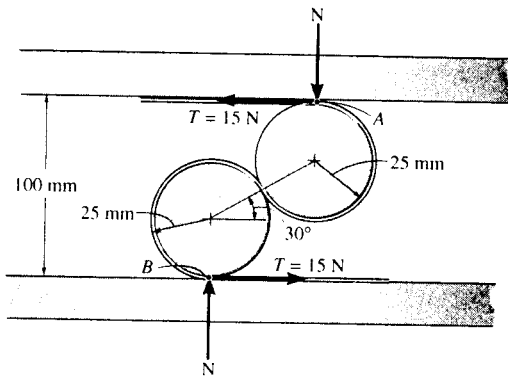

$$\left(+ \Sigma M_A = 0; \quad 15(50 + 50 \sin 30^\circ) - N(50 \cos 30^\circ) = 0 \right.$$

$$N = 26.0 \text{ N}$$

Ans

4-76. The caster wheel is subjected to the two couples. Determine the forces F that the bearings create on the shaft so that the resultant couple moment on the caster is zero.

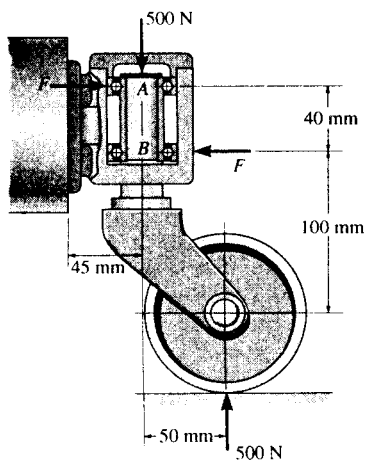

$$\left(+ \Sigma M_A = 0; \quad 500(50) - F(40) = 0 \right.$$

$$F = 625 \text{ N}$$

Ans

4-77. When the engine of the plane is running, the vertical reaction that the ground exerts on the wheel at A is measured as 650 lb. When the engine is turned off, however, the vertical reactions at A and B are 575 lb each. The difference in readings at A is caused by a couple acting on the propeller when the engine is running. This couple tends to overturn the plane counterclockwise, which is opposite to the propeller's clockwise rotation. Determine the magnitude of this couple and the magnitude of the reaction force exerted at B when the engine is running.

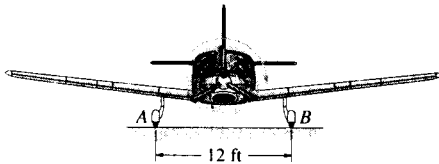

When the engine of the plane is turned on, the resulting couple moment exerts an additional force of $F = 650 - 575 = 75.0$ lb on wheel A and a lesser the reactive force on wheel B of $F = 75.0$ lb as well. Hence,

$$M = 75.0(12) = 900 \text{ lb} \cdot \text{ft} \quad \text{Ans}$$

The reactive force at wheel B is

$$R_B = 575 - 75.0 = 500 \text{ lb} \quad \text{Ans}$$

4-78. Two couples act on the beam. Determine the magnitude of F so that the resultant couple moment is $450 \text{ lb} \cdot \text{ft}$, counterclockwise. Where on the beam does the resultant couple moment act?

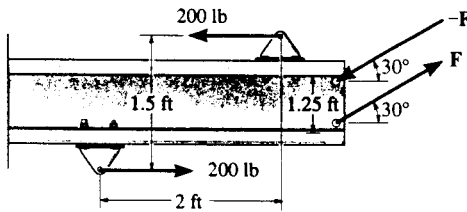

$$(+M_R = \Sigma M; \quad 450 = 200(1.5) + F \cos 30^\circ(1.25)$$

$$F = 139 \text{ lb} \quad \text{Ans}$$

The resultant couple moment is a free vector. It can act at any point on the beam.

4-79. Express the moment of the couple acting on the pipe assembly in Cartesian vector form. Solve the problem (a) using Eq. 4-13, and (b) summing the moment of each force about point O . Take $F = \{25\mathbf{k}\}$ N.

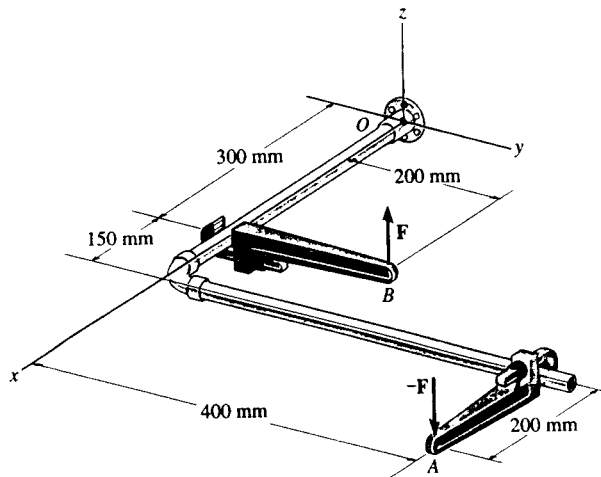

$$(a) \quad M_C = r_{AB} \times (25\mathbf{k})$$

$$= \begin{vmatrix} \mathbf{i} & \mathbf{j} & \mathbf{k} \\ -0.35 & -0.2 & 0 \\ 0 & 0 & 25 \end{vmatrix}$$

$$M_C = \{-5\mathbf{i} + 8.75\mathbf{j}\} \text{ N}\cdot\text{m} \quad \text{Ans}$$

$$(b) \quad M_C = r_{OB} \times (25\mathbf{k}) + r_{OA} \times (-25\mathbf{k})$$

$$= \begin{vmatrix} \mathbf{i} & \mathbf{j} & \mathbf{k} \\ 0.3 & 0.2 & 0 \\ 0 & 0 & 25 \end{vmatrix} + \begin{vmatrix} \mathbf{i} & \mathbf{j} & \mathbf{k} \\ 0.65 & 0.4 & 0 \\ 0 & 0 & -25 \end{vmatrix}$$

$$M_C = (5 - 10)\mathbf{i} + (-7.5 + 16.25)\mathbf{j}$$

$$M_C = \{-5\mathbf{i} + 8.75\mathbf{j}\} \text{ N}\cdot\text{m} \quad \text{Ans}$$

*4-80. If the couple moment acting on the pipe has a magnitude of $400 \text{ N}\cdot\text{m}$, determine the magnitude F of the vertical force applied to each wrench.

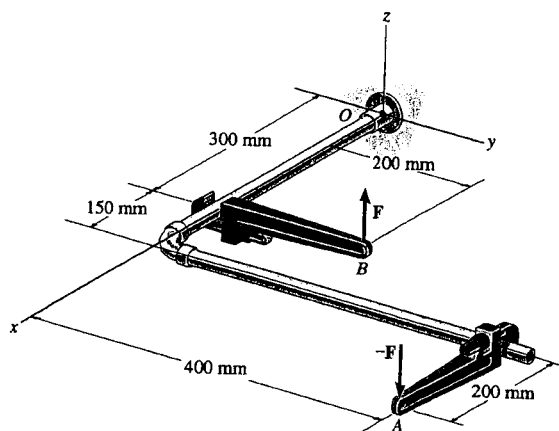

$$(a) \quad M_C = r_{AB} \times (F\mathbf{k})$$

$$= \begin{vmatrix} \mathbf{i} & \mathbf{j} & \mathbf{k} \\ -0.35 & -0.2 & 0 \\ 0 & 0 & F \end{vmatrix}$$

$$M_C = \{-0.2F\mathbf{i} + 0.35F\mathbf{j}\} \text{ N}\cdot\text{m}$$

$$M_C = \sqrt{(-0.2F)^2 + (0.35F)^2} = 400$$

$$F = \frac{400}{\sqrt{(-0.2)^2 + (0.35)^2}} = 992 \text{ N} \quad \text{Ans}$$

4-81. The ends of the triangular plate are subjected to three couples. Determine the plate dimension d so that the resultant couple is 350 N·m clockwise.

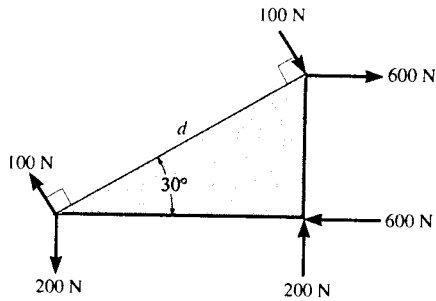

$$\begin{aligned} \curvearrowright + M_R = \Sigma M_A: \quad -350 &= 200(d \cos 30^\circ) - 600(d \sin 30^\circ) - 100d \\ d &= 1.54 \text{ m} \quad \text{Ans} \end{aligned}$$

4-82. Two couples act on the beam as shown. Determine the magnitude of F so that the resultant couple moment is 300 lb·ft counterclockwise. Where on the beam does the resultant couple act?

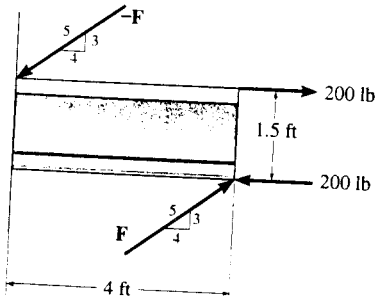

$$\curvearrowright + (M_C)_R = \frac{3}{5}F(4) + \frac{4}{5}F(1.5) - 200(1.5) = 300$$

$$F = 167 \text{ lb} \quad \text{Ans}$$

Resultant couple can act anywhere. Ans

4-83. Two couples act on the frame. If the resultant couple moment is to be zero, determine the distance d between the 80-lb couple forces.

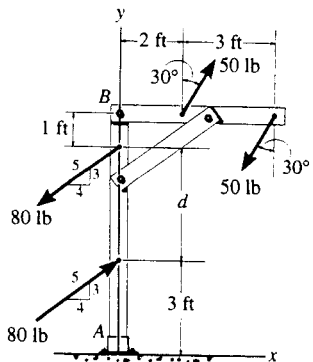

$$\curvearrowright + M_C = -50 \cos 30^\circ(3) + \frac{4}{5}(80)(d) = 0$$

$$d = 2.03 \text{ ft} \quad \text{Ans}$$

*4-84. Two couples act on the frame. If $d = 4$ ft, determine the resultant couple moment. Compute the result by resolving each force into x and y components and (a) finding the moment of each couple (Eq. 4-13) and (b) summing the moments of all the force components about point A .

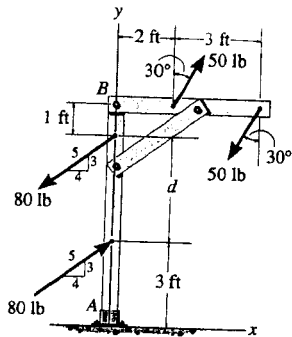

$$(a) \quad \mathbf{M}_C = \Sigma(\mathbf{r} \times \mathbf{F})$$

$$= \begin{vmatrix} \mathbf{i} & \mathbf{j} & \mathbf{k} \\ 3 & 0 & 0 \\ -50 \sin 30^\circ & -50 \cos 30^\circ & 0 \end{vmatrix} + \begin{vmatrix} \mathbf{i} & \mathbf{j} & \mathbf{k} \\ 0 & 4 & 0 \\ -\frac{4}{5}(80) & -\frac{3}{5}(80) & 0 \end{vmatrix}$$

$$\mathbf{M}_C = \{126\mathbf{k}\} \text{ lb}\cdot\text{ft} \quad \text{Ans}$$

$$(b) \quad \Sigma +M_C = -\frac{4}{5}(80)(3) + \frac{4}{5}(80)(7) + 50 \cos 30^\circ(2) - 50 \cos 30^\circ(5)$$

$$M_C = 126 \text{ lb}\cdot\text{ft} \quad \text{Ans}$$

4-85. Two couples act on the frame. If $d = 4$ ft, determine the resultant couple moment. Compute the result by resolving each force into x and y components and (a) finding the moment of each couple (Eq. 4-13) and (b) summing the moments of all the force components about point B .

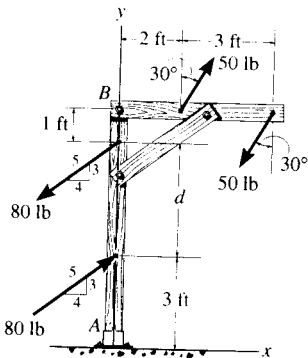

$$(a) \quad \mathbf{M}_C = \Sigma(\mathbf{r} \times \mathbf{F})$$

$$= \begin{vmatrix} \mathbf{i} & \mathbf{j} & \mathbf{k} \\ 3 & 0 & 0 \\ -50 \sin 30^\circ & -50 \cos 30^\circ & 0 \end{vmatrix} + \begin{vmatrix} \mathbf{i} & \mathbf{j} & \mathbf{k} \\ 0 & -4 & 0 \\ \frac{4}{5}(80) & \frac{3}{5}(80) & 0 \end{vmatrix}$$

$$\mathbf{M}_C = \{126\mathbf{k}\} \text{ lb}\cdot\text{ft} \quad \text{Ans}$$

$$(b) \quad \Sigma +M_C = 50 \cos 30^\circ(2) - 50 \cos 30^\circ(5) - \frac{4}{5}(80)(1) + \frac{4}{5}(80)(5)$$

$$M_C = 126 \text{ lb}\cdot\text{ft} \quad \text{Ans}$$

4-86. Determine the couple moment. Express the result as a Cartesian vector.

Position Vector:

$$\begin{aligned} \mathbf{r}_{AB} &= \{[0 - (-4)]\mathbf{i} + [-3 - 5]\mathbf{j} + [8 - (-6)]\mathbf{k}\} \text{ ft} \\ &= \{4\mathbf{i} - 8\mathbf{j} + 14\mathbf{k}\} \text{ ft} \end{aligned}$$

Couple Moment: With $\mathbf{F} = \{50\mathbf{i} - 20\mathbf{j} + 80\mathbf{k}\}$ lb, applying Eq. 4-15, we have

$$\begin{aligned} \mathbf{M}_C &= \mathbf{r}_{AB} \times \mathbf{F} \\ &= \begin{vmatrix} \mathbf{i} & \mathbf{j} & \mathbf{k} \\ 4 & -8 & 14 \\ 50 & -20 & 80 \end{vmatrix} \\ &= \{-360\mathbf{i} + 380\mathbf{j} + 320\mathbf{k}\} \text{ lb}\cdot\text{ft} \quad \text{Ans} \end{aligned}$$

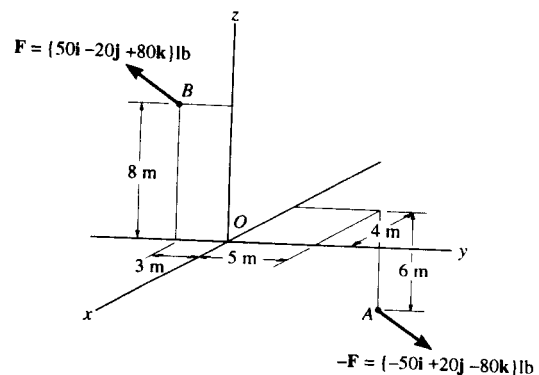

4-87. Determine the couple moment. Express the result as a Cartesian vector. Each force has a magnitude of $F = 120$ lb.

Position Vector and Force Vector :

$$\begin{aligned} \mathbf{r}_{BA} &= ((-3-2)\mathbf{i} + [6-(-2)]\mathbf{j} + (3-3)\mathbf{k}) \text{ ft} \\ &= (-5\mathbf{i} + 8\mathbf{j}) \text{ ft} \end{aligned}$$

$$\begin{aligned} \mathbf{F} &= 120 \left(\frac{[3-(-3)]\mathbf{i} + (4-6)\mathbf{j} + (0-3)\mathbf{k}}{\sqrt{[3-(-3)]^2 + (4-6)^2 + (0-3)^2}} \right) \\ &= \{102.86\mathbf{i} - 34.26\mathbf{j} - 51.43\mathbf{k}\} \text{ lb} \end{aligned}$$

Couple Moment : Applying Eq. 4-15, we have

$$\begin{aligned} \mathbf{M}_C &= \mathbf{r}_{BA} \times \mathbf{F} \\ &= \begin{vmatrix} \mathbf{i} & \mathbf{j} & \mathbf{k} \\ -5 & 8 & 0 \\ 102.86 & -34.26 & -51.43 \end{vmatrix} \\ &= \{-411\mathbf{i} - 257\mathbf{j} - 651\mathbf{k}\} \text{ lb}\cdot\text{ft} \end{aligned} \quad \text{Ans}$$

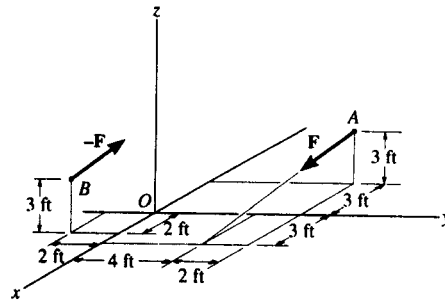

*4-88. The gear reducer is subjected to the four couple moments. Determine the magnitude of the resultant couple moment and its coordinate direction angles.

$$\begin{aligned} (M_R)_x &= \Sigma M_x; & (M_R)_x &= 35 + 50 = 85.0 \text{ N}\cdot\text{m} \\ (M_R)_y &= \Sigma M_y; & (M_R)_y &= 30 + 10 = 40.0 \text{ N}\cdot\text{m} \end{aligned}$$

The magnitude of the resultant couple moment is

$$\begin{aligned} M_R &= \sqrt{(M_R)_x^2 + (M_R)_y^2} \\ &= \sqrt{85.0^2 + 40.0^2} \\ &= 93.941 \text{ N}\cdot\text{m} = 93.9 \text{ N}\cdot\text{m} \end{aligned} \quad \text{Ans}$$

The coordinate direction angles are

$$\begin{aligned} \alpha &= \cos^{-1} \left[\frac{(M_R)_x}{M_R} \right] = \cos^{-1} \left(\frac{85.0}{93.941} \right) = 25.2^\circ & \text{Ans} \\ \beta &= \cos^{-1} \left[\frac{(M_R)_y}{M_R} \right] = \cos^{-1} \left(\frac{40.0}{93.941} \right) = 64.8^\circ & \text{Ans} \\ \gamma &= \cos^{-1} \left[\frac{(M_R)_z}{M_R} \right] = \cos^{-1} \left(\frac{0}{93.941} \right) = 90.0^\circ & \text{Ans} \end{aligned}$$

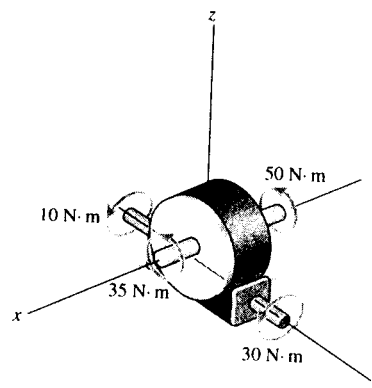

4-89. The main beam along the wing of an airplane is swept back at an angle of 25° . From load calculations it is determined that the beam is subjected to couple moments $M_x = 17 \text{ kip}\cdot\text{ft}$ and $M_y = 25 \text{ kip}\cdot\text{ft}$. Determine the resultant couple moments created about the x' and y' axes. The axes all lie in the same horizontal plane.

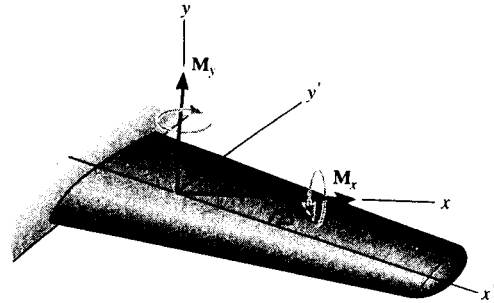

$$(M_R)_{x'} = \Sigma M_x; \quad (M_R)_{x'} = 17 \cos 25^\circ - 25 \sin 25^\circ = 4.84 \text{ kip}\cdot\text{ft} \quad \text{Ans}$$

$$(M_R)_{y'} = \Sigma M_y; \quad (M_R)_{y'} = 17 \sin 25^\circ + 25 \cos 25^\circ = 29.8 \text{ kip}\cdot\text{ft} \quad \text{Ans}$$

4-90. If $\mathbf{F} = \{100\mathbf{k}\} \text{ N}$, determine the couple moment that acts on the assembly. Express the result as a Cartesian vector. Member BA lies in the x - y plane.

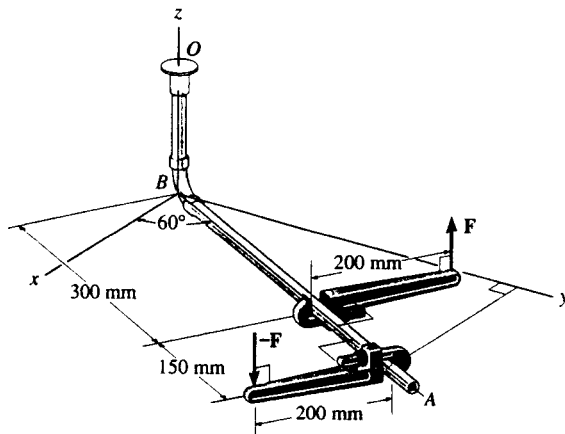

$$\phi = \tan^{-1}\left(\frac{2}{3}\right) - 30^\circ = 3.69^\circ$$

$$\mathbf{r}_1 = \{-360.6 \sin 3.69^\circ \mathbf{i} + 360.6 \cos 3.69^\circ \mathbf{j}\} \\ = \{-23.21 \mathbf{i} + 359.8 \mathbf{j}\} \text{ mm}$$

$$\theta = \tan^{-1}\left(\frac{2}{4.5}\right) + 30^\circ = 53.96^\circ$$

$$\mathbf{r}_2 = \{492.4 \sin 53.96^\circ \mathbf{i} + 492.4 \cos 53.96^\circ \mathbf{j}\} \\ = \{398.2 \mathbf{i} + 289.7 \mathbf{j}\} \text{ mm}$$

$$\mathbf{M}_C = (\mathbf{r}_1 - \mathbf{r}_2) \times \mathbf{F}$$

$$= \begin{vmatrix} \mathbf{i} & \mathbf{j} & \mathbf{k} \\ -421.4 & 70.10 & 0 \\ 0 & 0 & 100 \end{vmatrix}$$

$$\mathbf{M}_C = \{7.01 \mathbf{i} + 42.1 \mathbf{j}\} \text{ N}\cdot\text{m} \quad \text{Ans}$$

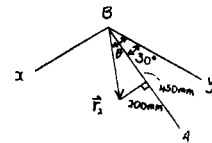
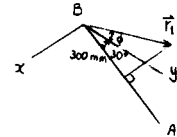

4-91. If the magnitude of the resultant couple moment is $15 \text{ N}\cdot\text{m}$, determine the magnitude F of the forces applied to the wrenches.

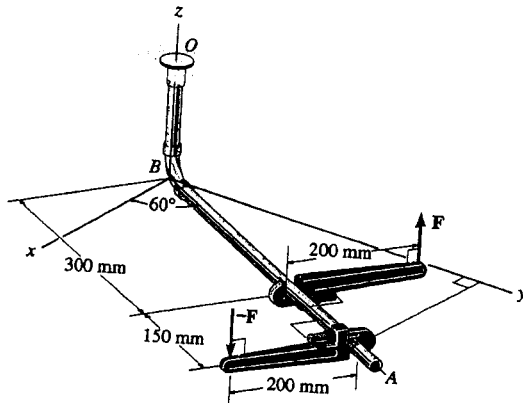

$$\phi = \tan^{-1}\left(\frac{2}{3}\right) - 30^\circ = 3.69^\circ$$

$$\begin{aligned} \mathbf{r}_1 &= \{-360.6 \sin 3.69^\circ \mathbf{i} + 360.6 \cos 3.69^\circ \mathbf{j}\} \\ &= \{-23.21 \mathbf{i} + 359.8 \mathbf{j}\} \text{ mm} \end{aligned}$$

$$\theta = \tan^{-1}\left(\frac{2}{4.5}\right) + 30^\circ = 53.96^\circ$$

$$\begin{aligned} \mathbf{r}_2 &= \{492.4 \sin 53.96^\circ \mathbf{i} + 492.4 \cos 53.96^\circ \mathbf{j}\} \\ &= \{398.2 \mathbf{i} + 289.7 \mathbf{j}\} \text{ mm} \end{aligned}$$

$$\mathbf{M}_C = (\mathbf{r}_1 - \mathbf{r}_2) \times \mathbf{F}$$

$$= \begin{vmatrix} \mathbf{i} & \mathbf{j} & \mathbf{k} \\ -421.4 & 70.10 & 0 \\ 0 & 0 & F \end{vmatrix}$$

$$\mathbf{M}_C = \{0.07F \mathbf{i} + 0.421F \mathbf{j}\} \text{ N}\cdot\text{m}$$

$$M_C = \sqrt{(0.07F)^2 + (0.421F)^2} = 15$$

$$F = \frac{15}{\sqrt{(0.07)^2 + (0.421)^2}} = 35.1 \text{ N} \quad \text{Ans}$$

Also, align y' axis along BA .

$$\mathbf{M}_C = -F(0.15) \mathbf{i}' - F(0.4) \mathbf{j}'$$

$$15 = \sqrt{(F(0.15))^2 + (F(0.4))^2}$$

$$F = 35.1 \text{ N} \quad \text{Ans}$$

4-92. The gear reducer is subjected to the couple moments shown. Determine the resultant couple moment and specify its magnitude and coordinate direction angles.

Express Each Couple Moment as a Cartesian Vector :

$$\mathbf{M}_1 = \{50 \mathbf{j}\} \text{ N}\cdot\text{m}$$

$$\mathbf{M}_2 = 60(\cos 30^\circ \mathbf{i} + \sin 30^\circ \mathbf{k}) \text{ N}\cdot\text{m} = \{51.96 \mathbf{i} + 30.0 \mathbf{k}\} \text{ N}\cdot\text{m}$$

Resultant Couple Moment :

$$\begin{aligned} \mathbf{M}_R &= \Sigma \mathbf{M}; \quad \mathbf{M}_R = \mathbf{M}_1 + \mathbf{M}_2 \\ &= \{51.96 \mathbf{i} + 50.0 \mathbf{j} + 30.0 \mathbf{k}\} \text{ N}\cdot\text{m} \end{aligned}$$

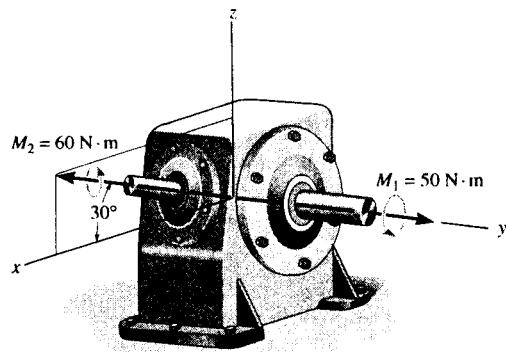

The magnitude of the resultant couple moment is

$$\begin{aligned} M_R &= \sqrt{51.96^2 + 50.0^2 + 30.0^2} \\ &= 78.102 \text{ N}\cdot\text{m} = 78.1 \text{ N}\cdot\text{m} \quad \text{Ans} \end{aligned}$$

The coordinate direction angles are

$$\alpha = \cos^{-1}\left(\frac{51.96}{78.102}\right) = 48.3^\circ \quad \text{Ans}$$

$$\beta = \cos^{-1}\left(\frac{50.0}{78.102}\right) = 50.2^\circ \quad \text{Ans}$$

$$\gamma = \cos^{-1}\left(\frac{30.0}{78.102}\right) = 67.4^\circ \quad \text{Ans}$$

4-91. If the magnitude of the resultant couple moment is $15 \text{ N} \cdot \text{m}$ determine the magnitude F of the forces applied to the wrenches.

$$\phi = \tan^{-1}\left(\frac{2}{3}\right) - 30^\circ = 3.69^\circ$$

$$\begin{aligned} \mathbf{r}_1 &= [-360.6 \sin 3.69^\circ \mathbf{i} + 360.6 \cos 3.69^\circ \mathbf{j}] \\ &= [-23.21 \mathbf{i} + 359.8 \mathbf{j}] \text{ mm} \end{aligned}$$

$$\theta = \tan^{-1}\left(\frac{2}{4.5}\right) + 30^\circ = 53.96^\circ$$

$$\begin{aligned} \mathbf{r}_2 &= [492.4 \sin 53.96^\circ \mathbf{i} + 492.4 \cos 53.96^\circ \mathbf{j}] \\ &= [398.2 \mathbf{i} + 289.7 \mathbf{j}] \text{ mm} \end{aligned}$$

$$\mathbf{M}_C = (\mathbf{r}_1 - \mathbf{r}_2) \times \mathbf{F}$$

$$= \begin{vmatrix} \mathbf{i} & \mathbf{j} & \mathbf{k} \\ -421.4 & 70.10 & 0 \\ 0 & 0 & F \end{vmatrix}$$

$$\mathbf{M}_C = \{0.07F \mathbf{i} + 0.421F \mathbf{j}\} \text{ N} \cdot \text{m}$$

$$M_C = \sqrt{(0.07F)^2 + (0.421F)^2} = 15$$

$$F = \frac{15}{\sqrt{(0.07)^2 + (0.421)^2}} = 35.1 \text{ N} \quad \text{Ans}$$

Also, align y' axis along BA .

$$\mathbf{M}_C = -F(0.15) \mathbf{i}' + F(0.4) \mathbf{j}'$$

$$15 = \sqrt{(F(0.15))^2 + (F(0.4))^2}$$

$$F = 35.1 \text{ N} \quad \text{Ans}$$

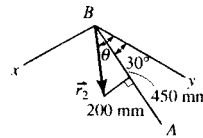
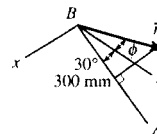
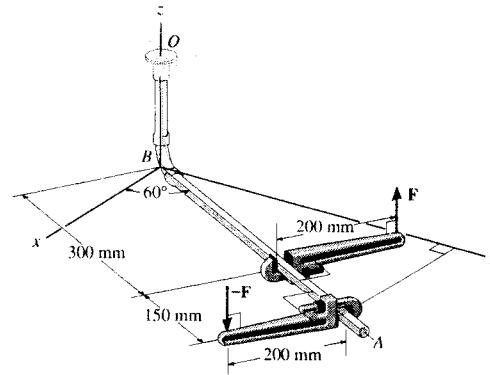

4-92. The gear reducer is subjected to the couple moments shown. Determine the resultant couple moment and specify its magnitude and coordinate direction angles.

Express Each Couple Moment as a Cartesian Vector:

$$\mathbf{M}_1 = \{50\mathbf{j}\} \text{ N} \cdot \text{m}$$

$$\mathbf{M}_2 = 60(\cos 30^\circ \mathbf{i} + \sin 30^\circ \mathbf{k}) \text{ N} \cdot \text{m} = \{51.96\mathbf{i} + 30.0\mathbf{k}\} \text{ N} \cdot \text{m}$$

Resultant Couple Moment:

$$\mathbf{M}_R = \Sigma \mathbf{M}; \quad \mathbf{M}_R = \mathbf{M}_1 + \mathbf{M}_2$$

$$= \{51.96\mathbf{i} + 50.0\mathbf{j} + 30.0\mathbf{k}\} \text{ N} \cdot \text{m}$$

The magnitude of the resultant couple moment is

$$M_R = \sqrt{51.96^2 + 50.0^2 + 30.0^2}$$

$$= 78.102 \text{ N} \cdot \text{m} = 78.1 \text{ N} \cdot \text{m} \quad \text{Ans}$$

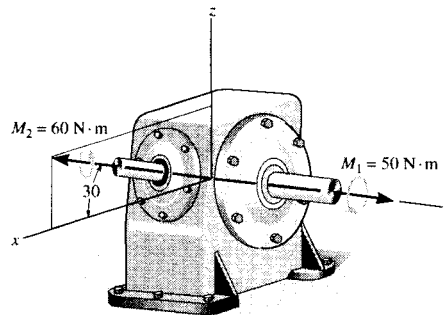

The coordinate direction angles are

$$\alpha = \cos^{-1}\left(\frac{51.96}{78.102}\right) = 48.3^\circ \quad \text{Ans}$$

$$\beta = \cos^{-1}\left(\frac{50.0}{78.102}\right) = 50.2^\circ \quad \text{Ans}$$

$$\gamma = \cos^{-1}\left(\frac{30.0}{78.102}\right) = 67.4^\circ \quad \text{Ans}$$

4-93. The gear reducer is subject to the couple moments shown. Determine the resultant couple moment and specify its magnitude and coordinate direction angles.

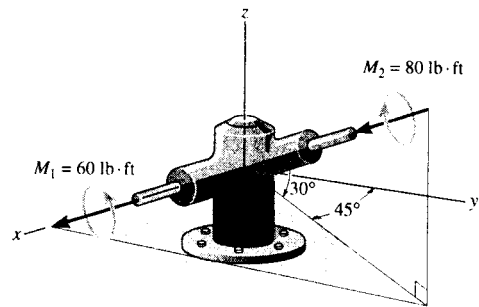

Express Each :

$$M_1 = \{60\mathbf{i}\} \text{ lb} \cdot \text{ft}$$

$$M_2 = 80(-\cos 30^\circ \sin 45^\circ \mathbf{i} - \cos 30^\circ \cos 45^\circ \mathbf{j} - \sin 30^\circ \mathbf{k}) \text{ lb} \cdot \text{ft}$$

$$= \{-48.99\mathbf{i} - 48.99\mathbf{j} - 40.0\mathbf{k}\} \text{ lb} \cdot \text{ft}$$

Resultant Couple Moment :

$$M_R = \Sigma M; \quad M_R = M_1 + M_2$$

$$= \{(60 - 48.99)\mathbf{i} - 48.99\mathbf{j} - 40.0\mathbf{k}\} \text{ lb} \cdot \text{ft}$$

$$= \{11.01\mathbf{i} - 48.99\mathbf{j} - 40.0\mathbf{k}\} \text{ lb} \cdot \text{ft}$$

$$= \{11.0\mathbf{i} - 49.0\mathbf{j} - 40.0\mathbf{k}\} \text{ lb} \cdot \text{ft} \quad \text{Ans}$$

The magnitude of the resultant couple moment is

$$M_R = \sqrt{11.01^2 + (-48.99)^2 + (-40.0)^2}$$

$$= 64.20 \text{ lb} \cdot \text{ft} = 64.2 \text{ lb} \cdot \text{ft} \quad \text{Ans}$$

The coordinate direction angles are

$$\alpha = \cos^{-1}\left(\frac{11.01}{64.20}\right) = 80.1^\circ \quad \text{Ans}$$

$$\beta = \cos^{-1}\left(\frac{-48.99}{64.20}\right) = 140^\circ \quad \text{Ans}$$

$$\gamma = \cos^{-1}\left(\frac{-40.0}{64.20}\right) = 129^\circ \quad \text{Ans}$$

4-94. The meshed gears are subjected to the couple moments shown. Determine the magnitude of the resultant couple moment and specify its coordinate direction angles.

$$M_1 = \{50\mathbf{k}\} \text{ N} \cdot \text{m}$$

$$M_2 = 20(-\cos 20^\circ \sin 30^\circ \mathbf{i} - \cos 20^\circ \cos 30^\circ \mathbf{j} + \sin 20^\circ \mathbf{k}) \text{ N} \cdot \text{m}$$

$$= \{-9.397\mathbf{i} - 16.276\mathbf{j} + 6.840\mathbf{k}\} \text{ N} \cdot \text{m}$$

Resultant Couple Moment :

$$M_R = \Sigma M; \quad M_R = M_1 + M_2$$

$$= \{-9.397\mathbf{i} - 16.276\mathbf{j} + (50 + 6.840)\mathbf{k}\} \text{ N} \cdot \text{m}$$

$$= \{-9.397\mathbf{i} - 16.276\mathbf{j} + 56.840\mathbf{k}\} \text{ N} \cdot \text{m}$$

The magnitude of the resultant couple moment is

$$M_R = \sqrt{(-9.397)^2 + (-16.276)^2 + (56.840)^2}$$

$$= 59.867 \text{ N} \cdot \text{m} = 59.9 \text{ N} \cdot \text{m} \quad \text{Ans}$$

The coordinate direction angles are

$$\alpha = \cos^{-1}\left(\frac{-9.397}{59.867}\right) = 99.0^\circ \quad \text{Ans}$$

$$\beta = \cos^{-1}\left(\frac{-16.276}{59.867}\right) = 106^\circ \quad \text{Ans}$$

$$\gamma = \cos^{-1}\left(\frac{56.840}{59.867}\right) = 18.3^\circ \quad \text{Ans}$$

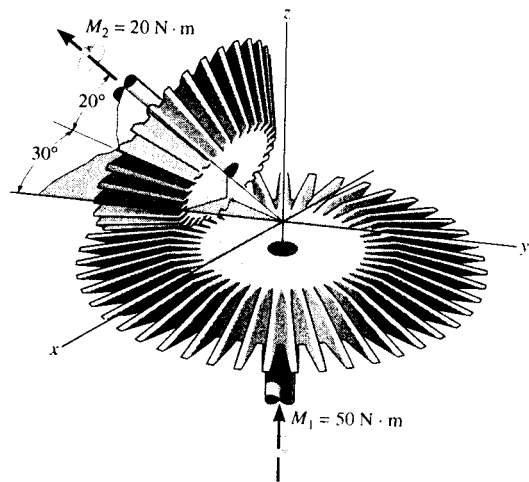

4-95. A couple acts on each of the handles of the minidial valve. Determine the magnitude and coordinate direction angles of the resultant couple moment.

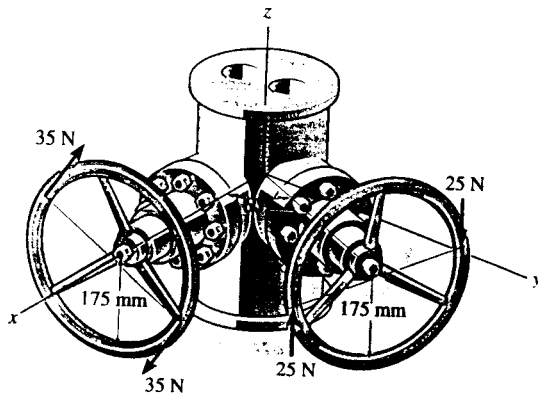

$$M_x = -35(0.35) - 25(0.35) \cos 60^\circ = -16.625$$

$$M_y = -25(0.35) \sin 60^\circ = -7.5777 \text{ N}\cdot\text{m}$$

$$|M| = \sqrt{(-16.625)^2 + (-7.5777)^2} = 18.2705 = 18.3 \text{ N}\cdot\text{m}$$

$$\alpha = \cos^{-1}\left(\frac{-16.625}{18.2705}\right) = 155^\circ \quad \text{Ans}$$

$$\beta = \cos^{-1}\left(\frac{-7.5777}{18.2705}\right) = 115^\circ \quad \text{Ans}$$

$$\gamma = \cos^{-1}\left(\frac{0}{18.2705}\right) = 90^\circ \quad \text{Ans}$$

*4-96. Determine the resultant couple moment of the two couples that act on the pipe assembly. The distance from A to B is $d = 400$ mm. Express the result as a Cartesian vector.

Vector Analysis

Position Vector :

$$\begin{aligned} \mathbf{r}_{AB} &= \{(0.35 - 0.35)\mathbf{i} + (-0.4 \cos 30^\circ - 0)\mathbf{j} + (0.4 \sin 30^\circ - 0)\mathbf{k}\} \text{ m} \\ &= \{-0.3464\mathbf{j} + 0.20\mathbf{k}\} \text{ m} \end{aligned}$$

Couple Moments : With $\mathbf{F}_1 = \{35\mathbf{k}\}$ N and $\mathbf{F}_2 = \{-50\mathbf{i}\}$ N, applying Eq. 4-15, we have

$$\begin{aligned} (\mathbf{M}_C)_1 &= \mathbf{r}_{AB} \times \mathbf{F}_1 \\ &= \begin{vmatrix} \mathbf{i} & \mathbf{j} & \mathbf{k} \\ 0 & -0.3464 & 0.20 \\ 0 & 0 & 35 \end{vmatrix} = \{-12.12\mathbf{i}\} \text{ N}\cdot\text{m} \end{aligned}$$

$$\begin{aligned} (\mathbf{M}_C)_2 &= \mathbf{r}_{AB} \times \mathbf{F}_2 \\ &= \begin{vmatrix} \mathbf{i} & \mathbf{j} & \mathbf{k} \\ 0 & -0.3464 & 0.20 \\ -50 & 0 & 0 \end{vmatrix} = \{-10.0\mathbf{j} - 17.32\mathbf{k}\} \text{ N}\cdot\text{m} \end{aligned}$$

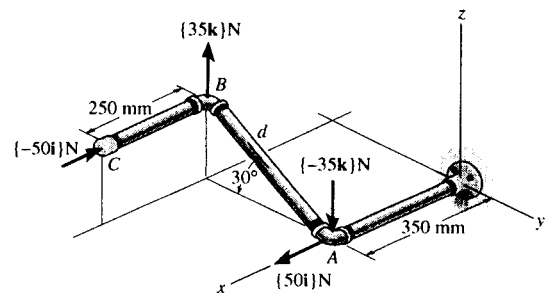

Resultant Couple Moment :

$$\begin{aligned} \mathbf{M}_R &= \Sigma \mathbf{M}; \quad \mathbf{M}_R = (\mathbf{M}_C)_1 + (\mathbf{M}_C)_2 \\ &= \{-12.1\mathbf{i} - 10.0\mathbf{j} - 17.3\mathbf{k}\} \text{ N}\cdot\text{m} \quad \text{Ans} \end{aligned}$$

Scalar Analysis : Summing moments about x , y and z axes, we have

$$\begin{aligned} (\mathbf{M}_R)_x &= \Sigma M_x; \quad (\mathbf{M}_R)_x = -35(0.4 \cos 30^\circ) = -12.12 \text{ N}\cdot\text{m} \\ (\mathbf{M}_R)_y &= \Sigma M_y; \quad (\mathbf{M}_R)_y = -50(0.4 \sin 30^\circ) = -10.0 \text{ N}\cdot\text{m} \\ (\mathbf{M}_R)_z &= \Sigma M_z; \quad (\mathbf{M}_R)_z = -50(0.4 \cos 30^\circ) = -17.32 \text{ N}\cdot\text{m} \end{aligned}$$

Express \mathbf{M}_R as a Cartesian vector, we have

$$\mathbf{M}_R = \{-12.1\mathbf{i} - 10.0\mathbf{j} - 17.3\mathbf{k}\} \text{ N}\cdot\text{m}$$

4-97. Determine the distance d between A and B so that the resultant couple moment has a magnitude of $M_R = 20 \text{ N}\cdot\text{m}$.

Position Vector :

$$\begin{aligned} \mathbf{r}_{AB} &= \{(0.35 - 0.35)\mathbf{i} + (-d\cos 30^\circ - 0)\mathbf{j} + (d\sin 30^\circ - 0)\mathbf{k}\} \text{ m} \\ &= \{-0.8660d\mathbf{j} + 0.50d\mathbf{k}\} \text{ m} \end{aligned}$$

Couple Moments : With $\mathbf{F}_1 = \{35\mathbf{k}\} \text{ N}$ and $\mathbf{F}_2 = \{-50\mathbf{i}\} \text{ N}$, applying Eq. 4-15, we have

$$\begin{aligned} (\mathbf{M}_C)_1 &= \mathbf{r}_{AB} \times \mathbf{F}_1 \\ &= \begin{vmatrix} \mathbf{i} & \mathbf{j} & \mathbf{k} \\ 0 & -0.8660d & 0.50d \\ 0 & 0 & 35 \end{vmatrix} = \{-30.31d\mathbf{i}\} \text{ N}\cdot\text{m} \end{aligned}$$

$$\begin{aligned} (\mathbf{M}_C)_2 &= \mathbf{r}_{AB} \times \mathbf{F}_2 \\ &= \begin{vmatrix} \mathbf{i} & \mathbf{j} & \mathbf{k} \\ 0 & -0.8660d & 0.50d \\ -50 & 0 & 0 \end{vmatrix} = \{-25.0d\mathbf{j} - 43.30d\mathbf{k}\} \text{ N}\cdot\text{m} \end{aligned}$$

Resultant Couple Moment :

$$\begin{aligned} \mathbf{M}_R &= \Sigma \mathbf{M}; \quad \mathbf{M}_R = (\mathbf{M}_C)_1 + (\mathbf{M}_C)_2 \\ &= \{-30.31d\mathbf{i} - 25.0d\mathbf{j} - 43.30d\mathbf{k}\} \text{ N}\cdot\text{m} \end{aligned}$$

The magnitude of \mathbf{M}_R is $20 \text{ N}\cdot\text{m}$ thus

$$20 = \sqrt{(-30.31d)^2 + (-25.0d)^2 + (43.30d)^2}$$

$$d = 0.3421 \text{ m} = 342 \text{ mm}$$

Ans

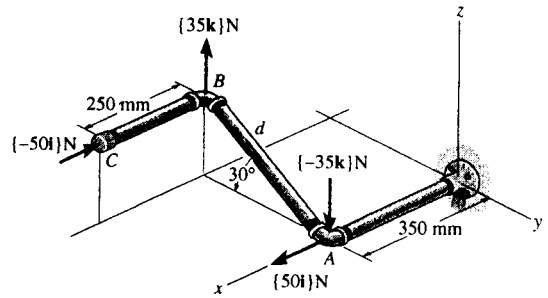

4-98. Replace the force at A by an equivalent force and couple moment at point O .

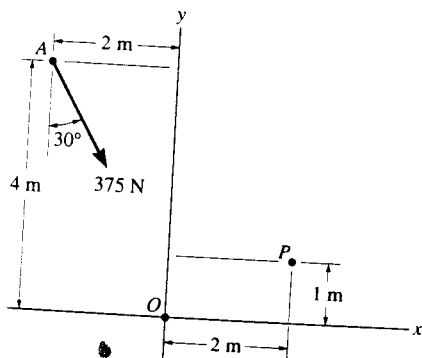

$$F = 375 \text{ N} \quad \text{Ans}$$

$$(+M_O = 375 \cos 30^\circ(2) - 375 \sin 30^\circ(4))$$

$$M_O = -100.48 = 100 \text{ N}\cdot\text{m} \quad \text{Ans}$$

4-99. Replace the force at A by an equivalent force and couple moment at point P .

$$F_P = 375 \text{ N} \quad \text{Ans}$$

$$(+M_P = 375 \cos 30^\circ(4) - 375 \sin 30^\circ(3))$$

$$M_P = 737 \text{ N}\cdot\text{m} \quad \text{Ans}$$

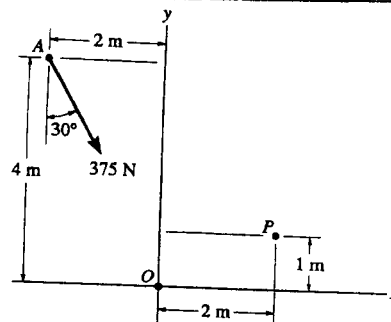

4-100. Replace the force and couple moment system by an equivalent force and couple moment acting at point O .

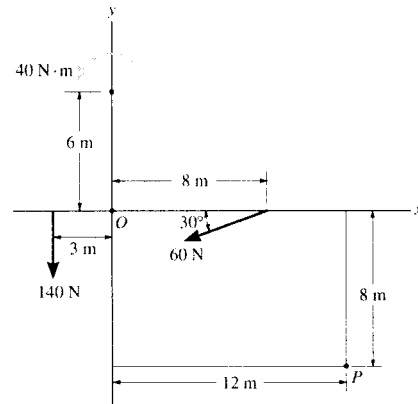

$$\begin{aligned} \rightarrow F_{R_x} &= \Sigma F_x; & F_{R_x} &= -60 \cos 30^\circ = -51.96 \text{ N} = 51.96 \text{ N} \leftarrow \\ + \uparrow F_{R_y} &= \Sigma F_y; & F_{R_y} &= -60 \sin 30^\circ - 140 \\ & & &= -170.0 \text{ N} = 170.0 \text{ N} \downarrow \end{aligned}$$

Thus,

$$F_R = \sqrt{F_{R_x}^2 + F_{R_y}^2} = \sqrt{51.96^2 + 170.0^2} = 178 \text{ N} \quad \text{Ans}$$

and

$$\theta = \tan^{-1} \left(\frac{F_{R_y}}{F_{R_x}} \right) = \tan^{-1} \left(\frac{170.0}{51.96} \right) = 73.0^\circ \quad \text{Ans}$$

$$\begin{aligned} \curvearrowright + M_{R_o} &= \Sigma M_o; & M_{R_o} &= -60 \sin 30^\circ (8) + 40 + 140(3) \\ & & &= 220 \text{ N} \cdot \text{m} \quad (\text{Counterclockwise}) \quad \text{Ans} \end{aligned}$$

4-101. Replace the force and couple moment system by an equivalent force and couple moment acting at point P .

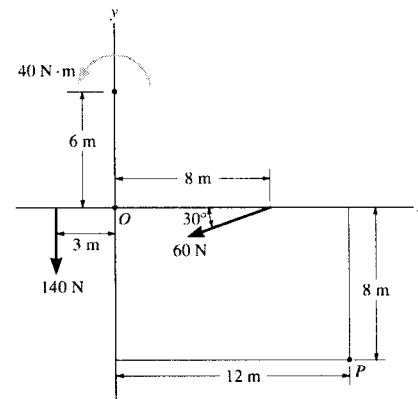

$$\begin{aligned} \rightarrow F_{R_x} &= \Sigma F_x; & F_{R_x} &= -60 \cos 30^\circ = -51.96 \text{ N} = 51.96 \text{ N} \leftarrow \\ + \uparrow F_{R_y} &= \Sigma F_y; & F_{R_y} &= -60 \sin 30^\circ - 140 \\ & & &= -170.0 \text{ N} = 170.0 \text{ N} \downarrow \end{aligned}$$

Thus,

$$F_R = \sqrt{F_{R_x}^2 + F_{R_y}^2} = \sqrt{51.96^2 + 170.0^2} = 178 \text{ N} \quad \text{Ans}$$

and

$$\theta = \tan^{-1} \left(\frac{F_{R_y}}{F_{R_x}} \right) = \tan^{-1} \left(\frac{170.0}{51.96} \right) = 73.0^\circ \quad \text{Ans}$$

$$\begin{aligned} \curvearrowright + M_{R_p} &= \Sigma M_p; & M_{R_p} &= 60 \sin 30^\circ (12 - 8) + 60 \cos 30^\circ (8) \\ & & &+ 40 + 140(3 + 12) \\ & & &= 2676 \text{ N} \cdot \text{m} \\ & & &= 2.68 \text{ kN} \cdot \text{m} \quad (\text{Counterclockwise}) \quad \text{Ans} \end{aligned}$$

4-102. Replace the force system by an equivalent force and couple moment at point O .

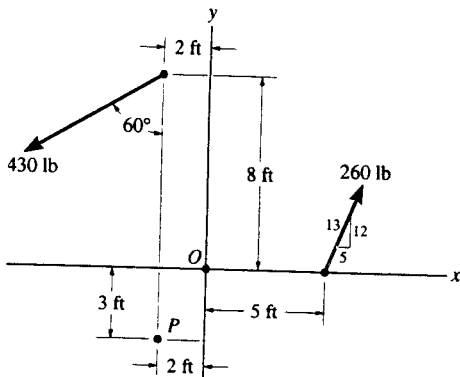

$$\begin{aligned} \rightarrow \Sigma F_{Rx} = \Sigma F_x; \quad F_{Rx} &= 260\left(\frac{5}{13}\right) - 430 \sin 60^\circ \\ &= -272.39 \text{ lb} \end{aligned}$$

$$\begin{aligned} + \uparrow \Sigma F_{Ry} = \Sigma F_y; \quad F_{Ry} &= 260\left(\frac{12}{13}\right) - 430 \cos 60^\circ \\ &= 25 \text{ lb} \end{aligned}$$

$$F_R = \sqrt{(-272.39)^2 + (25)^2} = 274 \text{ lb} \quad \text{Ans}$$

$$\theta = \tan^{-1}\left[\frac{25}{272.39}\right] = 5.24^\circ \quad \text{e}_{\Delta} \quad \text{Ans}$$

$$\begin{aligned} (+) M_O = \Sigma M_O; \quad M_O &= 430 \cos 60^\circ(2) + 430 \sin 60^\circ(8) + 260\left(\frac{12}{13}\right)(5) \\ M_O &= 4609 \text{ lb}\cdot\text{ft} = 4.61 \text{ kip}\cdot\text{ft} \quad \text{Ans} \end{aligned}$$

4-103. Replace the force system by an equivalent force and couple moment at point P .

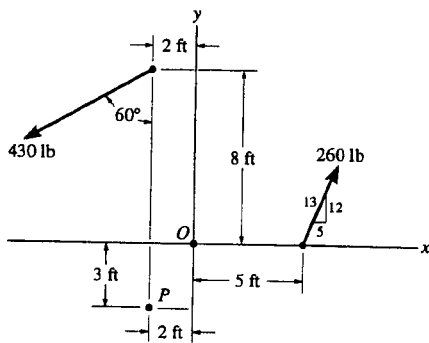

$$\begin{aligned} \rightarrow \Sigma F_{Rx} = \Sigma F_x; \quad F_{Rx} &= 260\left(\frac{5}{13}\right) - 430 \sin 60^\circ \\ &= -272.39 \text{ lb} \end{aligned}$$

$$\begin{aligned} + \uparrow \Sigma F_{Ry} = \Sigma F_y; \quad F_{Ry} &= 260\left(\frac{12}{13}\right) - 430 \cos 60^\circ \\ &= 25 \text{ lb} \end{aligned}$$

$$F_R = \sqrt{(-272.39)^2 + (25)^2} = 274 \text{ lb} \quad \text{Ans}$$

$$\theta = \tan^{-1}\left[\frac{25}{272.39}\right] = 5.24^\circ \quad \text{e}_{\Delta} \quad \text{Ans}$$

$$\begin{aligned} (+) M_P = \Sigma M_P; \quad M_P &= 430 \sin 60^\circ(11) + 260\left(\frac{12}{13}\right)(7) - 260\left(\frac{5}{13}\right)(3) \\ M_P &= 5.48 \text{ kip}\cdot\text{ft} \quad \text{Ans} \end{aligned}$$

***4-104.** Replace the force and couple system by an equivalent force and couple moment acting at point O.

Note that the 6 kN pair of forces form a couple.

$$\begin{aligned} \rightarrow F_{R_x} &= \Sigma F_x; & F_{R_x} &= 5 \cos 45^\circ = 3.536 \text{ kN} \rightarrow \\ + \uparrow F_{R_y} &= \Sigma F_y; & F_{R_y} &= -5 \sin 45^\circ - 2 \\ & & &= -5.536 \text{ kN} = 5.536 \text{ kN} \downarrow \end{aligned}$$

Thus,

$$F_R = \sqrt{F_{R_x}^2 + F_{R_y}^2} = \sqrt{3.536^2 + 5.536^2} = 6.57 \text{ kN} \quad \text{Ans}$$

and

$$\theta = \tan^{-1} \left(\frac{F_{R_y}}{F_{R_x}} \right) = \tan^{-1} \left(\frac{5.536}{3.536} \right) = 57.4^\circ \quad \text{Ans}$$

$$\begin{aligned} \curvearrowright +M_{R_o} &= \Sigma M_o; & M_{R_o} &= 6(3) + 2(4.5) - 5 \sin 45^\circ(2) \\ & & &= 19.9 \text{ kN} \cdot \text{m} \quad (\text{Counterclockwise}) \quad \text{Ans} \end{aligned}$$

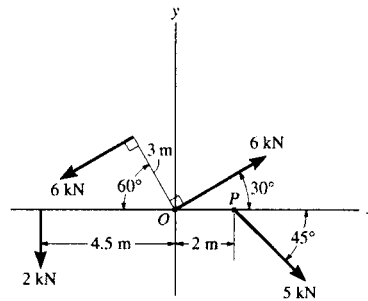

4-105. Replace the force and couple system by an equivalent force and couple moment acting at point P.

Note that the 6 kN pair of forces form a couple.

$$\begin{aligned} \rightarrow F_{R_x} &= \Sigma F_x; & F_{R_x} &= 5 \cos 45^\circ = 3.536 \text{ kN} \rightarrow \\ + \uparrow F_{R_y} &= \Sigma F_y; & F_{R_y} &= -5 \sin 45^\circ - 2 \\ & & &= -5.536 \text{ kN} = 5.536 \text{ kN} \downarrow \end{aligned}$$

Thus,

$$F_R = \sqrt{F_{R_x}^2 + F_{R_y}^2} = \sqrt{3.536^2 + 5.536^2} = 6.57 \text{ kN} \quad \text{Ans}$$

and

$$\theta = \tan^{-1} \left(\frac{F_{R_y}}{F_{R_x}} \right) = \tan^{-1} \left(\frac{5.536}{3.536} \right) = 57.4^\circ \quad \curvearrowright \quad \text{Ans}$$

$$\begin{aligned} \curvearrowright +M_{R_p} &= \Sigma M_p; & M_{R_p} &= 6(3) + 2(4.5 + 2) - 5(0) \\ & & &= 31.0 \text{ kN} \cdot \text{m} \quad (\text{Counterclockwise}) \quad \text{Ans} \end{aligned}$$

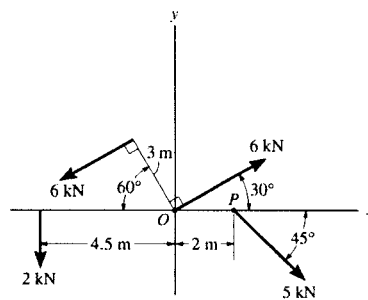

4-106. Replace the force and couple system by an equivalent force and couple moment at point O .

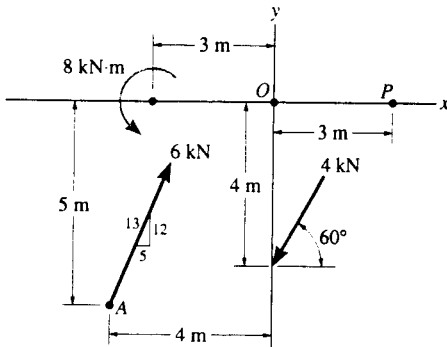

$$\begin{aligned} \rightarrow \Sigma F_{Rx} = \Sigma F_x; \quad F_{Rx} &= 6\left(\frac{5}{13}\right) - 4 \cos 60^\circ \\ &= 0.30769 \text{ kN} \end{aligned}$$

$$\begin{aligned} + \uparrow \Sigma F_{Ry} = \Sigma F_y; \quad F_{Ry} &= 6\left(\frac{12}{13}\right) - 4 \sin 60^\circ \\ &= 2.0744 \text{ kN} \end{aligned}$$

$$F_R = \sqrt{(0.30769)^2 + (2.0744)^2} = 2.10 \text{ kN} \quad \text{Ans}$$

$$\theta = \tan^{-1}\left[\frac{2.0744}{0.30769}\right] = 81.6^\circ \angle \theta \quad \text{Ans}$$

$$\begin{aligned} (+) M_O = \Sigma M_O; \quad M_O &= 8 - 6\left(\frac{12}{13}\right)(4) + 6\left(\frac{5}{13}\right)(5) - 4 \cos 60^\circ(4) \\ M_O &= -10.62 \text{ kN}\cdot\text{m} = 10.6 \text{ kN}\cdot\text{m} \quad \text{Ans} \end{aligned}$$

4-107. Replace the force and couple system by an equivalent force and couple moment at point P .

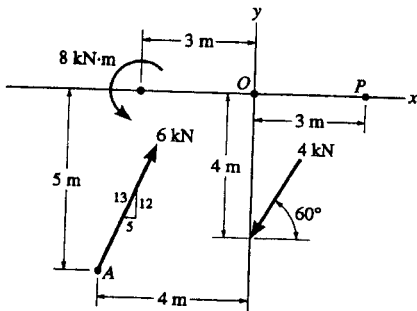

$$\begin{aligned} \rightarrow \Sigma F_{Rx} = \Sigma F_x; \quad F_{Rx} &= 6\left(\frac{5}{13}\right) - 4 \cos 60^\circ \\ &= 0.30769 \text{ kN} \end{aligned}$$

$$\begin{aligned} + \uparrow \Sigma F_{Ry} = \Sigma F_y; \quad F_{Ry} &= 6\left(\frac{12}{13}\right) - 4 \sin 60^\circ \\ &= 2.0744 \text{ kN} \end{aligned}$$

$$F_R = \sqrt{(0.30769)^2 + (2.0744)^2} = 2.10 \text{ kN} \quad \text{Ans}$$

$$\theta = \tan^{-1}\left[\frac{2.0744}{0.30769}\right] = 81.6^\circ \angle \theta \quad \text{Ans}$$

$$\begin{aligned} (+) M_P = \Sigma M_P; \quad M_P &= 8 - 6\left(\frac{12}{13}\right)(7) + 6\left(\frac{5}{13}\right)(5) - 4 \cos 60^\circ(4) + 4 \sin 60^\circ(3) \\ M_P &= -16.8 \text{ kN}\cdot\text{m} = 16.8 \text{ kN}\cdot\text{m} \quad \text{Ans} \end{aligned}$$

*4-108. Replace the force system by a single force resultant and specify its point of application, measured along the x axis from point O .

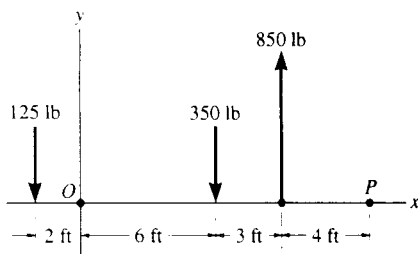

$$+\uparrow \Sigma F_{Ry} = \Sigma F_y; \quad F_{Ry} = 850 - 350 - 125 = 375 \text{ lb}$$

$$F_R = 375 \text{ lb } \uparrow \quad \text{Ans}$$

$$(+M_{RO} = \Sigma M_O; \quad 375(x) = 850(9) - 350(6) + 125(2)$$

$$x = 15.5 \text{ ft} \quad \text{Ans}$$

4-109. Replace the force system by a single force resultant and specify its point of application, measured along the x axis from point P .

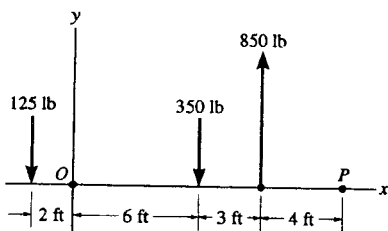

$$+\uparrow \Sigma F_{Ry} = \Sigma F_y; \quad F_{Ry} = 850 - 350 - 125 = 375 \text{ lb}$$

$$F_R = 375 \text{ lb } \uparrow \quad \text{Ans}$$

$$(+M_{RP} = \Sigma M_P; \quad 375(x) = 350(7) - 850(4) + 125(15)$$

$$x = 2.47 \text{ ft} \quad \text{Ans} \quad (\text{to the left})$$

4-110. Replace the force system acting on the beam by an equivalent force and couple moment at point A.

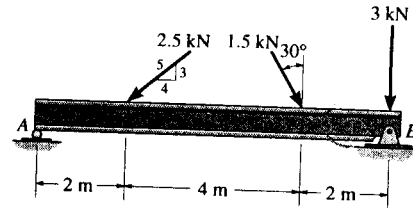

$$\begin{aligned} \rightarrow F_{R_x} = \Sigma F_x; \quad F_{R_x} &= 1.5 \sin 30^\circ - 2.5 \left(\frac{4}{5}\right) \\ &= -1.25 \text{ kN} = 1.25 \text{ kN} \leftarrow \end{aligned}$$

$$\begin{aligned} + \uparrow F_{R_y} = \Sigma F_y; \quad F_{R_y} &= -1.5 \cos 30^\circ - 2.5 \left(\frac{3}{5}\right) - 3 \\ &= -5.799 \text{ kN} = 5.799 \text{ kN} \downarrow \end{aligned}$$

Thus,

$$F_R = \sqrt{F_{R_x}^2 + F_{R_y}^2} = \sqrt{1.25^2 + 5.799^2} = 5.93 \text{ kN}$$

and

$$\theta = \tan^{-1} \left(\frac{F_{R_y}}{F_{R_x}} \right) = \tan^{-1} \left(\frac{5.799}{1.25} \right) = 77.8^\circ$$

Ans

Ans

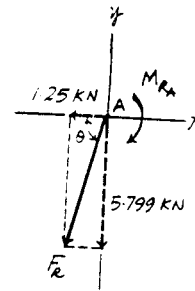

$$\begin{aligned} \curvearrowright + M_{R_A} = \Sigma M_A; \quad M_{R_A} &= -2.5 \left(\frac{3}{5}\right)(2) - 1.5 \cos 30^\circ(6) - 3(8) \\ &= -34.8 \text{ kN} \cdot \text{m} = 34.8 \text{ kN} \cdot \text{m} \text{ (Clockwise)} \end{aligned} \quad \text{Ans}$$

4-111. Replace the force system acting on the beam by an equivalent force and couple moment at point B.

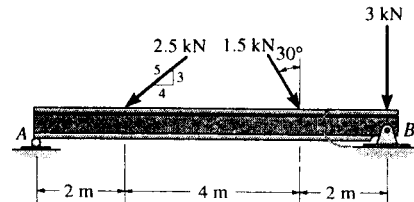

$$\begin{aligned} \rightarrow F_{R_x} = \Sigma F_x; \quad F_{R_x} &= 1.5 \sin 30^\circ - 2.5 \left(\frac{4}{5}\right) \\ &= -1.25 \text{ kN} = 1.25 \text{ kN} \leftarrow \end{aligned}$$

$$\begin{aligned} + \uparrow F_{R_y} = \Sigma F_y; \quad F_{R_y} &= -1.5 \cos 30^\circ - 2.5 \left(\frac{3}{5}\right) - 3 \\ &= -5.799 \text{ kN} = 5.799 \text{ kN} \downarrow \end{aligned}$$

Thus,

$$F_R = \sqrt{F_{R_x}^2 + F_{R_y}^2} = \sqrt{1.25^2 + 5.799^2} = 5.93 \text{ kN}$$

and

$$\theta = \tan^{-1} \left(\frac{F_{R_y}}{F_{R_x}} \right) = \tan^{-1} \left(\frac{5.799}{1.25} \right) = 77.8^\circ$$

Ans

Ans

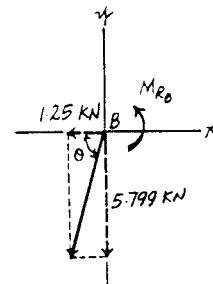

$$\begin{aligned} \curvearrowleft + M_{R_B} = \Sigma M_B; \quad M_{R_B} &= 1.5 \cos 30^\circ(2) + 2.5 \left(\frac{3}{5}\right)(6) \\ &= 11.6 \text{ kN} \cdot \text{m} \text{ (Counterclockwise)} \end{aligned} \quad \text{Ans}$$

***4-112.** Replace the three forces acting on the shaft by a single resultant force. Specify where the force acts, measured from end A.

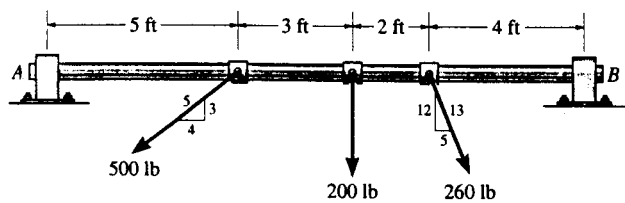

$$\rightarrow F_{Rx} = \Sigma F_x; \quad F_{Rx} = -500\left(\frac{4}{5}\right) + 260\left(\frac{5}{13}\right) = -300 \text{ lb} = 300 \text{ lb} \leftarrow$$

$$+\uparrow F_{Ry} = \Sigma F_y; \quad F_{Ry} = -500\left(\frac{3}{5}\right) - 200 - 260\left(\frac{12}{13}\right) = -740 \text{ lb} = 740 \text{ lb} \downarrow$$

$$F = \sqrt{(-300)^2 + (-740)^2} = 798 \text{ lb} \quad \text{Ans}$$

$$\theta = \tan^{-1}\left(\frac{740}{300}\right) = 67.9^\circ \text{ } \overleftrightarrow{xy} \quad \text{Ans}$$

$$+\circlearrowleft M_{RA} = \Sigma M_A; \quad 740(x) = 500\left(\frac{3}{5}\right)(5) + 200(8) + 260\left(\frac{12}{13}\right)(10)$$

$$740(x) = 5500$$

$$x = 7.43 \text{ ft} \quad \text{Ans}$$

4-113. Replace the three forces acting on the shaft by a single resultant force. Specify where the force acts, measured from end B.

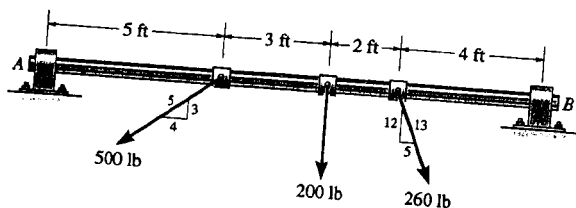

$$\rightarrow F_{Rx} = \Sigma F_x; \quad F_{Rx} = -500\left(\frac{4}{5}\right) + 260\left(\frac{5}{13}\right) = -300 \text{ lb} = 300 \text{ lb} \leftarrow$$

$$+\uparrow F_{Ry} = \Sigma F_y; \quad F_{Ry} = -500\left(\frac{3}{5}\right) - 200 - 260\left(\frac{12}{13}\right) = -740 \text{ lb} = 740 \text{ lb} \downarrow$$

$$F = \sqrt{(-300)^2 + (-740)^2} = 798 \text{ lb} \quad \text{Ans}$$

$$\theta = \tan^{-1}\left(\frac{740}{300}\right) = 67.9^\circ \text{ } \overleftrightarrow{xy} \quad \text{Ans}$$

$$(+\circlearrowleft M_{RB} = \Sigma M_B; \quad 740(x) = 500\left(\frac{3}{5}\right)(9) + 200(6) + 260\left(\frac{12}{13}\right)(4)$$

$$x = 6.57 \text{ ft} \quad \text{Ans}$$

4-114. Replace the loading on the frame by a single resultant force. Specify where its line of action intersects member AB, measured from A.

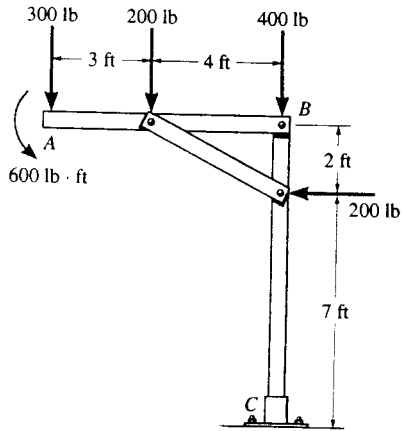

$$\rightarrow F_{Rx} = \Sigma F_x; \quad F_{Rx} = -200 \text{ lb} = 200 \text{ lb} \leftarrow$$

$$+\uparrow F_{Ry} = \Sigma F_y; \quad F_{Ry} = -300 - 200 - 400 = -900 \text{ lb} = 900 \text{ lb} \downarrow$$

$$F = \sqrt{(-200)^2 + (-900)^2} = 922 \text{ lb} \quad \text{Ans}$$

$$\theta = \tan^{-1}\left(\frac{900}{200}\right) = 77.5^\circ \quad \text{Ans}$$

$$\zeta + M_{RA} = \Sigma M_A; \quad 900(x) = 200(3) + 400(7) + 200(2) - 600$$

$$x = \frac{3200}{900} = 3.56 \text{ ft} \quad \text{Ans}$$

4-115. Replace the three forces acting on the beam by a single resultant force. Specify where the force acts, measured from end A.

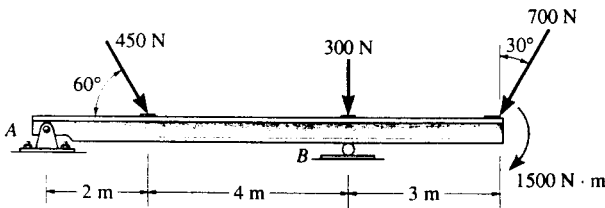

$$\rightarrow F_{Rx} = \Sigma F_x; \quad F_{Rx} = 450 \cos 60^\circ - 700 \sin 30^\circ = -125 \text{ N} = 125 \text{ N} \leftarrow$$

$$+\uparrow F_{Ry} = \Sigma F_y; \quad F_{Ry} = -450 \sin 60^\circ - 700 \cos 30^\circ - 300 = -1296 \text{ N} = 1296 \text{ N} \downarrow$$

$$F = \sqrt{(-125)^2 + (-1296)^2} = 1302 \text{ N} \quad \text{Ans}$$

$$\theta = \tan^{-1}\left(\frac{1296}{125}\right) = 84.5^\circ \quad \text{Ans}$$

$$\zeta + M_{RA} = \Sigma M_A; \quad 1296(x) = 450 \sin 60^\circ(2) + 300(6) + 700 \cos 30^\circ(9) + 1500$$

$$x = 7.36 \text{ m} \quad \text{Ans}$$

*4-116. Replace the three forces acting on the beam by a single resultant force. Specify where the force acts, measured from B.

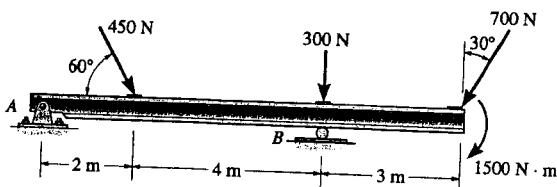

$$\rightarrow F_{Rx} = \Sigma F_x; \quad F_{Rx} = 450 \cos 60^\circ - 700 \sin 30^\circ = -125 \text{ N} = 125 \text{ N} \leftarrow$$

$$+\uparrow F_{Ry} = \Sigma F_y; \quad F_{Ry} = -450 \sin 60^\circ - 700 \cos 30^\circ - 300 = -1296 \text{ N} = 1296 \text{ N} \downarrow$$

$$F = \sqrt{(-125)^2 + (-1296)^2} = 1302 \text{ N} \quad \text{Ans}$$

$$\theta = \tan^{-1}\left(\frac{1296}{125}\right) = 84.5^\circ \quad \text{Ans}$$

$$\zeta + M_{RB} = \Sigma M_B; \quad 1296(x) = -450 \sin 60^\circ(4) + 700 \cos 30^\circ(3) + 1500$$

$$x = 1.36 \text{ m (to the right)} \quad \text{Ans}$$

4-117. Determine the magnitudes of F_1 and F_2 and the direction of F_1 so that the loading creates a zero resultant force and couple moment on the wheel.

Force Summation :

$$\begin{aligned} \rightarrow 0 = \Sigma F_x; \quad 0 &= F_2 + 60 - F_1 \cos \theta - 30 \cos 45^\circ \\ F_2 - F_1 \cos \theta &= -38.79 \end{aligned} \quad [1]$$

$$\begin{aligned} + \uparrow 0 = \Sigma F_y; \quad 0 &= F_1 \sin \theta - 30 \sin 45^\circ \\ F_1 \sin \theta &= 21.21 \end{aligned} \quad [2]$$

Moment Summation :

$$\begin{aligned} \curvearrowright + 0 = \Sigma M_O; \quad 0 &= 80 - F_2(0.75) - 30(0.75) \\ &\quad - F_1 \sin \theta(0.75 \cos 30^\circ) \\ &\quad - F_1 \cos \theta(0.75 \sin 30^\circ) \end{aligned}$$

$$0.6495 F_1 \sin \theta + 0.375 F_1 \cos \theta - 0.75 F_2 = 57.5 \quad [3]$$

Solving Eqs. [1], [2] and [3] yields

$$F_2 = 25.9 \text{ lb} \quad \theta = 18.1^\circ \quad F_1 = 68.1 \text{ lb} \quad \text{Ans}$$

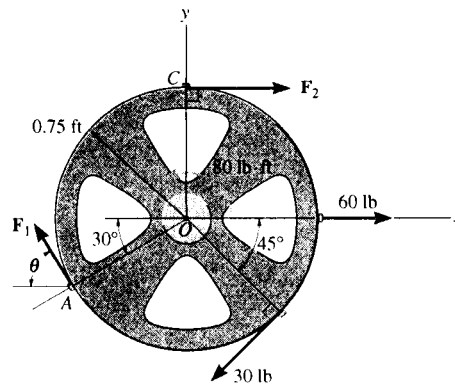

4-118. The weights of the various components of the truck are shown. Replace this system of forces by an equivalent resultant force and couple moment acting at point A.

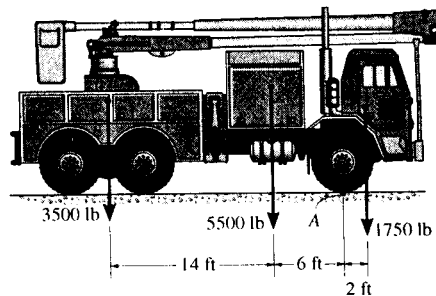

$$\begin{aligned} + \uparrow F_R = \Sigma F_y; \quad F_R &= -1750 - 5500 - 3500 \\ &= -10750 \text{ lb} = 10.75 \text{ kip} \downarrow \end{aligned} \quad \text{Ans}$$

$$\begin{aligned} \curvearrowright + M_{R_A} = \Sigma M_A; \quad M_{R_A} &= 3500(20) + 5500(6) - 1750(2) \\ &= 99500 \text{ lb} \cdot \text{ft} \\ &= 99.5 \text{ kip} \cdot \text{ft} \quad (\text{Counterclockwise}) \end{aligned} \quad \text{Ans}$$

4-119. The weights of the various components of the truck are shown. Replace this system of forces by an equivalent resultant force and specify its location measured from point A.

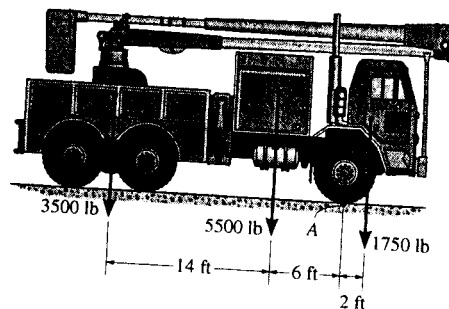

Equivalent Force :

$$+\uparrow F_R = \Sigma F_y; \quad F_R = -1750 - 5500 - 3500 \\ = -10750 \text{ lb} = 10.75 \text{ kip} \downarrow \quad \text{Ans}$$

Location of Resultant Force From Point A :

$$\curvearrowright + M_{R_A} = \Sigma M_A; \quad 10750(d) = 3500(20) + 5500(6) - 1750(2)$$

$$d = 9.26 \text{ ft} \quad \text{Ans}$$

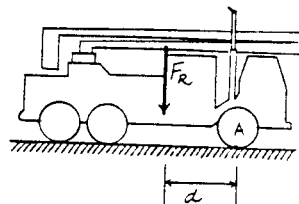

*4-120. Replace the loading on the frame by a single resultant force. Specify where its line of action intersects member AB, measured from A.

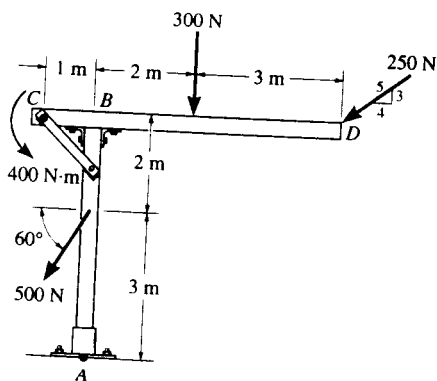

$$\rightarrow \Sigma F_x = F_{R_x}; \quad F_{R_x} = -250\left(\frac{4}{5}\right) - 500(\cos 60^\circ) = -450 \text{ N} = 450 \text{ N} \leftarrow$$

$$+\uparrow \Sigma F_y = \Sigma F_y; \quad F_{R_y} = -300 - 250\left(\frac{3}{5}\right) - 500 \sin 60^\circ = -883.0127 \text{ N} = 883.0127 \text{ N} \downarrow$$

$$F_R = \sqrt{(-450)^2 + (-883.0127)^2} = 991 \text{ N} \quad \text{Ans}$$

$$\theta = \tan^{-1}\left(\frac{883.0127}{450}\right) = 63.0^\circ \nearrow$$

$$\curvearrowright + M_{R_A} = \Sigma M_A; \quad 450y = 400 + (500 \cos 60^\circ)(3) + 250\left(\frac{4}{5}\right)(5) - 300(2) - 250\left(\frac{3}{5}\right)(5)$$

$$y = \frac{800}{450} = 1.78 \text{ m} \quad \text{Ans}$$

4-121. Replace the loading on the frame by a single resultant force. Specify where its line of action intersects member CD , measured from end C .

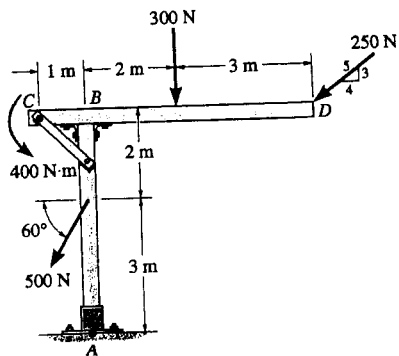

$$\rightarrow \Sigma F_x = F_{Rx}; \quad F_{Rx} = -250\left(\frac{4}{5}\right) - 500(\cos 60^\circ) = -450 \text{ N} = 450 \text{ N} \leftarrow$$

$$+\uparrow \Sigma F_y = \Sigma F_y; \quad F_{Ry} = -300 - 250\left(\frac{3}{5}\right) - 500 \sin 60^\circ = -883.0127 \text{ N} = 883.0127 \text{ N} \downarrow$$

$$F_R = \sqrt{(-450)^2 + (-883.0127)^2} = 991 \text{ N} \quad \text{Ans}$$

$$\theta = \tan^{-1}\left(\frac{883.0127}{450}\right) = 63.0^\circ \nearrow$$

$$\zeta + M_{RA} = \Sigma M_C; \quad 883.0127 x = -400 + 300(3) + 250\left(\frac{3}{5}\right)(6) + 500 \cos 60^\circ(2) + (500 \sin 60^\circ)(1)$$

$$x = \frac{2333}{883.0127} = 2.64 \text{ m} \quad \text{Ans}$$

4-122. Replace the force system acting on the frame by an equivalent resultant force and specify where the resultant's line of action intersects member AB , measured from point A .

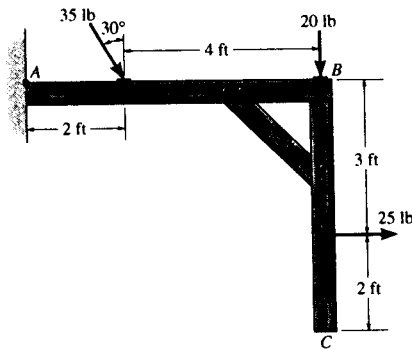

$$\rightarrow F_{Rx} = \Sigma F_x; \quad F_{Rx} = 35 \sin 30^\circ + 25 = 42.5 \text{ lb}$$

$$+\downarrow F_{Ry} = \Sigma F_y; \quad F_{Ry} = 35 \cos 30^\circ + 20 = 50.31 \text{ lb}$$

$$F_R = \sqrt{(42.5)^2 + (50.31)^2} = 65.9 \text{ lb} \quad \text{Ans}$$

$$\theta = \tan^{-1}\left(\frac{50.31}{42.5}\right) = 49.8^\circ \swarrow \text{Ans}$$

$$\zeta + M_{RA} = \Sigma M_A; \quad 50.31(d) = 35 \cos 30^\circ(2) + 20(6) - 25(3)$$

$$d = 2.10 \text{ ft} \quad \text{Ans}$$

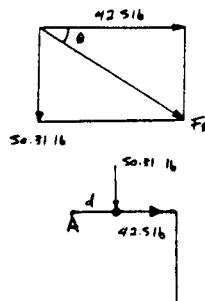

4-123. Replace the force system acting on the frame by an equivalent resultant force and specify where the resultant's line of action intersects member BC , measured from point B .

$$\rightarrow F_{Rx} = \Sigma F_x; \quad F_{Rx} = 35 \sin 30^\circ + 25 = 42.5 \text{ lb}$$

$$+\downarrow F_{Ry} = \Sigma F_y; \quad F_{Ry} = 35 \cos 30^\circ + 20 = 50.31 \text{ lb}$$

$$F_R = \sqrt{(42.5)^2 + (50.31)^2} = 65.9 \text{ lb} \quad \text{Ans}$$

$$\theta = \tan^{-1} \left(\frac{50.31}{42.5} \right) = 49.8^\circ \quad \text{Ans}$$

$$\left(+M_{RA} = \Sigma M_A; \quad 50.31(6) - 42.5(d) = 35 \cos 30^\circ(2) + 20(6) - 25(3) \right)$$

$$d = 4.62 \text{ ft} \quad \text{Ans}$$

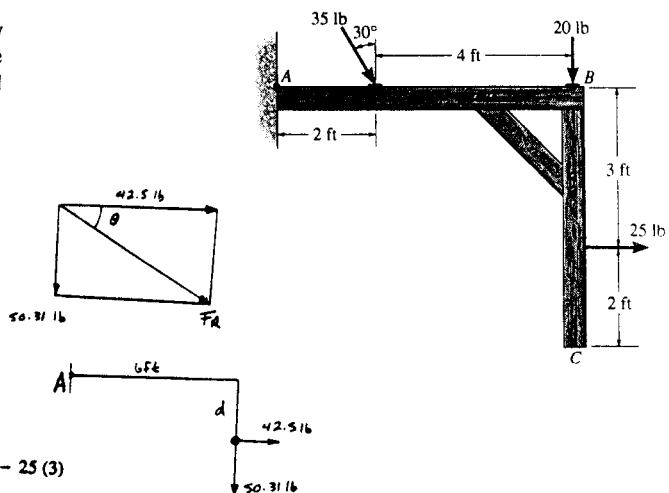

*4-124. Replace the force system acting on the frame by an equivalent resultant force and couple moment acting at point A .

$$\rightarrow F_{Rx} = \Sigma F_x; \quad F_{Rx} = 35 \sin 30^\circ + 25 = 42.5 \text{ lb}$$

$$+\downarrow F_{Ry} = \Sigma F_y; \quad F_{Ry} = 35 \cos 30^\circ + 20 = 50.31 \text{ lb}$$

$$F_R = \sqrt{(42.5)^2 + (50.31)^2} = 65.9 \text{ lb} \quad \text{Ans}$$

$$\theta = \tan^{-1} \left(\frac{50.31}{42.5} \right) = 49.8^\circ \quad \text{Ans}$$

$$\left(+M_{RA} = \Sigma M_A; \quad M_{RA} = 35 \cos 30^\circ(2) + 20(6) - 25(3) \right)$$

$$M_{RA} = 104 \text{ lb} \cdot \text{ft} \quad \text{Ans}$$

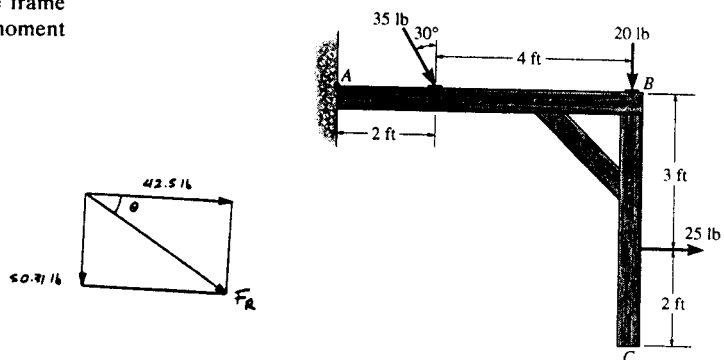

4-125. Replace the force and couple-moment system by an equivalent resultant force and couple moment at point O . Express the results in Cartesian vector form.

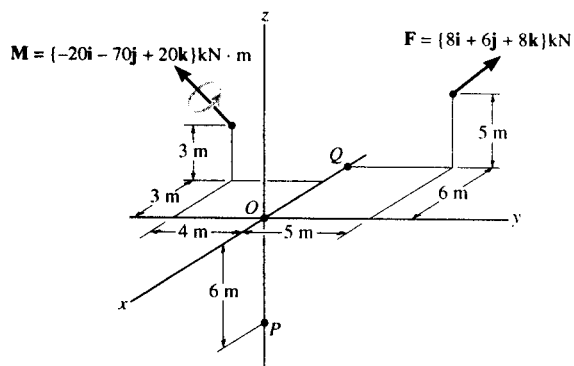

$$\mathbf{F}_R = \Sigma \mathbf{F}; \quad \mathbf{F}_R = (8\mathbf{i} + 6\mathbf{j} + 8\mathbf{k}) \text{ kN} \quad \text{Ans}$$

$$\mathbf{M}_{RO} = \Sigma \mathbf{M}_O; \quad \mathbf{M}_{RO} = -20\mathbf{i} - 70\mathbf{j} + 20\mathbf{k} + \begin{vmatrix} \mathbf{i} & \mathbf{j} & \mathbf{k} \\ -6 & 5 & 5 \\ 8 & 6 & 8 \end{vmatrix}$$

$$= (-10\mathbf{i} + 18\mathbf{j} - 56\mathbf{k}) \text{ kN} \cdot \text{m} \quad \text{Ans}$$

4-126. Replace the force and couple-moment system by an equivalent resultant force and couple moment at point P . Express the results in Cartesian vector form.

$$\mathbf{F}_R = (8\mathbf{i} + 6\mathbf{j} + 8\mathbf{k}) \text{ kN} \quad \text{Ans}$$

$$\mathbf{M}_{RP} = \Sigma \mathbf{M}_P = -20\mathbf{i} - 70\mathbf{j} + 20\mathbf{k} + \begin{vmatrix} \mathbf{i} & \mathbf{j} & \mathbf{k} \\ -6 & 5 & 11 \\ 8 & 6 & 8 \end{vmatrix}$$

$$= (-46\mathbf{i} + 66\mathbf{j} - 56\mathbf{k}) \text{ kN}\cdot\text{m} \quad \text{Ans}$$

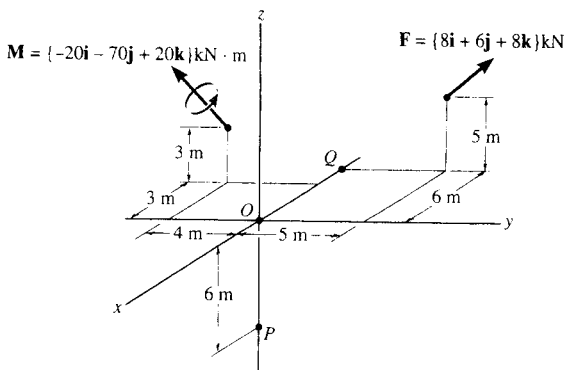

4-127. Replace the force and couple-moment system by an equivalent resultant force and couple moment at point Q . Express the results in Cartesian vector form.

$$\mathbf{F}_R = (8\mathbf{i} + 6\mathbf{j} + 8\mathbf{k}) \text{ kN} \quad \text{Ans}$$

$$\mathbf{M}_{RQ} = -20\mathbf{i} - 70\mathbf{j} + 20\mathbf{k} + \begin{vmatrix} \mathbf{i} & \mathbf{j} & \mathbf{k} \\ 0 & 5 & 5 \\ 8 & 6 & 8 \end{vmatrix}$$

$$= (-10\mathbf{i} - 30\mathbf{j} - 20\mathbf{k}) \text{ kN}\cdot\text{m} \quad \text{Ans}$$

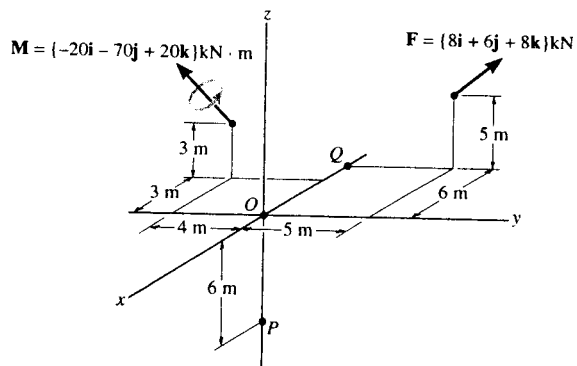

*4-128. The belt passing over the pulley is subjected to forces F_1 and F_2 , each having a magnitude of 40 N. F_1 acts in the $-\mathbf{k}$ direction. Replace these forces by an equivalent force and couple moment at point A . Express the result in Cartesian vector form. Set $\theta = 0^\circ$ so that F_2 acts in the $-\mathbf{j}$ direction.

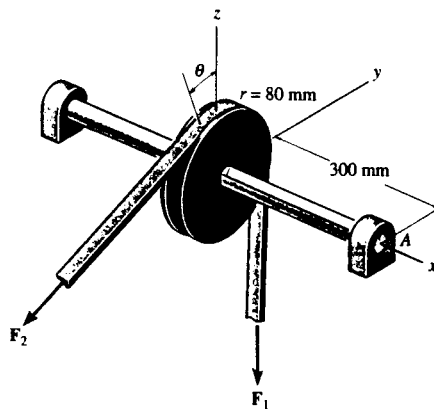

$$\mathbf{F}_R = \mathbf{F}_1 + \mathbf{F}_2$$

$$\mathbf{F}_R = \{-40\mathbf{j} - 40\mathbf{k}\} \text{ N} \quad \text{Ans}$$

$$\mathbf{M}_{RA} = \Sigma(\mathbf{r} \times \mathbf{F})$$

$$= \begin{vmatrix} \mathbf{i} & \mathbf{j} & \mathbf{k} \\ -0.3 & 0 & 0.08 \\ 0 & -40 & 0 \end{vmatrix} + \begin{vmatrix} \mathbf{i} & \mathbf{j} & \mathbf{k} \\ -0.3 & 0.08 & 0 \\ 0 & 0 & -40 \end{vmatrix}$$

$$\mathbf{M}_{RA} = \{-12\mathbf{j} + 12\mathbf{k}\} \text{ N}\cdot\text{m} \quad \text{Ans}$$

4-129. The belt passing over the pulley is subjected to two forces F_1 and F_2 , each having a magnitude of 40 N. F_1 acts in the $-k$ direction. Replace these forces by an equivalent force and couple moment at point A. Express the result in Cartesian vector form. Take $\theta = 45^\circ$.

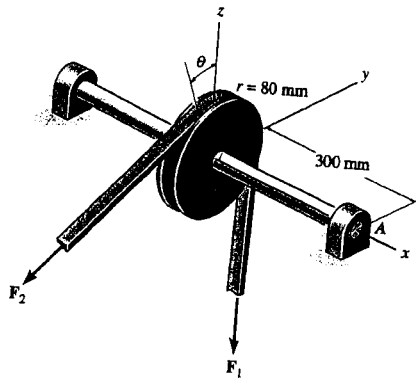

$$\begin{aligned} \mathbf{F}_R &= \mathbf{F}_1 + \mathbf{F}_2 \\ &= -40 \cos 45^\circ \mathbf{j} + (-40 - 40 \sin 45^\circ) \mathbf{k} \end{aligned}$$

$$\mathbf{F}_R = \{-28.3\mathbf{j} - 68.3\mathbf{k}\} \text{ N} \quad \text{Ans}$$

$$\mathbf{r}_{AF1} = \{-0.3\mathbf{i} + 0.08\mathbf{j}\} \text{ m}$$

$$\begin{aligned} \mathbf{r}_{AF2} &= -0.3\mathbf{i} - 0.08 \sin 45^\circ \mathbf{j} + 0.08 \cos 45^\circ \mathbf{k} \\ &= \{-0.3\mathbf{i} - 0.0566\mathbf{j} + 0.0566\mathbf{k}\} \text{ m} \end{aligned}$$

$$\mathbf{M}_{RA} = (\mathbf{r}_{AF1} \times \mathbf{F}_1) + (\mathbf{r}_{AF2} \times \mathbf{F}_2)$$

$$= \begin{vmatrix} \mathbf{i} & \mathbf{j} & \mathbf{k} \\ -0.3 & 0.08 & 0 \\ 0 & 0 & -40 \end{vmatrix} + \begin{vmatrix} \mathbf{i} & \mathbf{j} & \mathbf{k} \\ -0.3 & -0.0566 & 0.0566 \\ 0 & -40 \cos 45^\circ & -40 \sin 45^\circ \end{vmatrix}$$

$$\mathbf{M}_{RA} = \{-20.5\mathbf{j} + 8.49\mathbf{k}\} \text{ N}\cdot\text{m} \quad \text{Ans}$$

Also,

$$M_{RA_z} = \Sigma M_{A_z}$$

$$M_{RA_z} = 28.28(0.0566) + 28.28(0.0566) - 40(0.08)$$

$$M_{RA_z} = 0$$

$$M_{RA_y} = \Sigma M_{A_y}$$

$$M_{RA_y} = -28.28(0.3) - 40(0.3)$$

$$M_{RA_y} = -20.5 \text{ N}\cdot\text{m}$$

$$M_{RA_x} = \Sigma M_{A_x}$$

$$M_{RA_x} = 28.28(0.3)$$

$$M_{RA_x} = 8.49 \text{ N}\cdot\text{m}$$

$$\mathbf{M}_{RA} = \{-20.5\mathbf{j} + 8.49\mathbf{k}\} \text{ N}\cdot\text{m} \quad \text{Ans}$$

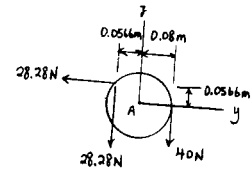

4-130. Replace the force system by an equivalent force and couple moment at point A.

$$\begin{aligned} \mathbf{F}_R &= \Sigma \mathbf{F}; \quad \mathbf{F}_R = \mathbf{F}_1 + \mathbf{F}_2 + \mathbf{F}_3 \\ &= (300 + 100)\mathbf{i} + (400 - 100)\mathbf{j} + (-100 - 50 - 500)\mathbf{k} \\ &= \{400\mathbf{i} + 300\mathbf{j} - 650\mathbf{k}\} \text{ N} \quad \text{Ans} \end{aligned}$$

The position vectors are $\mathbf{r}_{AB} = \{12\mathbf{k}\}$ m and $\mathbf{r}_{AE} = \{-1\mathbf{j}\}$ m.

$$\begin{aligned} \mathbf{M}_{R_A} &= \Sigma \mathbf{M}_A; \quad \mathbf{M}_{R_A} = \mathbf{r}_{AB} \times \mathbf{F}_1 + \mathbf{r}_{AE} \times \mathbf{F}_2 + \mathbf{r}_{AE} \times \mathbf{F}_3 \\ &= \begin{vmatrix} \mathbf{i} & \mathbf{j} & \mathbf{k} \\ 0 & 0 & 12 \\ 300 & 400 & -100 \end{vmatrix} + \begin{vmatrix} \mathbf{i} & \mathbf{j} & \mathbf{k} \\ 0 & 0 & 12 \\ 100 & -100 & -50 \end{vmatrix} \\ &\quad + \begin{vmatrix} \mathbf{i} & \mathbf{j} & \mathbf{k} \\ 0 & -1 & 0 \\ 0 & 0 & -500 \end{vmatrix} \\ &= \{-3100\mathbf{i} + 4800\mathbf{j}\} \text{ N} \cdot \text{m} \quad \text{Ans} \end{aligned}$$

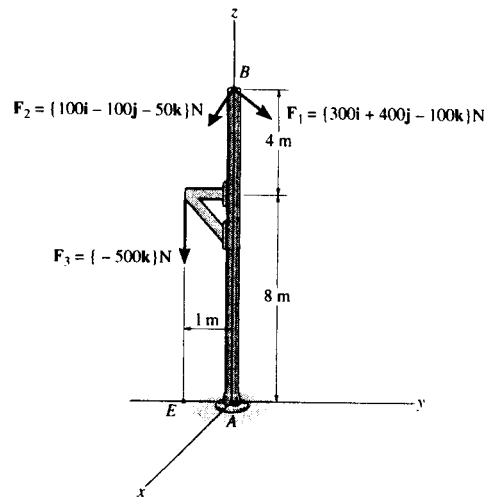

4-131. The slab is to be hoisted using the three slings shown. Replace the system of forces acting on slings by an equivalent force and couple moment at point O. The force \mathbf{F}_1 , is vertical.

Force Vectors :

$$\mathbf{F}_1 = \{6.00\mathbf{k}\} \text{ kN}$$

$$\begin{aligned} \mathbf{F}_2 &= 5(-\cos 45^\circ \sin 30^\circ \mathbf{i} + \cos 45^\circ \cos 30^\circ \mathbf{j} + \sin 45^\circ \mathbf{k}) \\ &= \{-1.768\mathbf{i} + 3.062\mathbf{j} + 3.536\mathbf{k}\} \text{ kN} \end{aligned}$$

$$\begin{aligned} \mathbf{F}_3 &= 4(\cos 60^\circ \mathbf{i} + \cos 60^\circ \mathbf{j} + \cos 45^\circ \mathbf{k}) \\ &= \{2.00\mathbf{i} + 2.00\mathbf{j} + 2.828\mathbf{k}\} \text{ kN} \end{aligned}$$

Equivalent Force and Couple Moment At Point O :

$$\begin{aligned} \mathbf{F}_R &= \Sigma \mathbf{F}; \quad \mathbf{F}_R = \mathbf{F}_1 + \mathbf{F}_2 + \mathbf{F}_3 \\ &= (-1.768 + 2.00)\mathbf{i} + (3.062 + 2.00)\mathbf{j} \\ &\quad + (6.00 + 3.536 + 2.828)\mathbf{k} \\ &= \{0.232\mathbf{i} + 5.06\mathbf{j} + 12.4\mathbf{k}\} \text{ kN} \quad \text{Ans} \end{aligned}$$

The position vectors are $\mathbf{r}_1 = \{2\mathbf{i} + 6\mathbf{j}\}$ m and $\mathbf{r}_2 = \{4\mathbf{i}\}$ m.

$$\begin{aligned} \mathbf{M}_{R_O} &= \Sigma \mathbf{M}_O; \quad \mathbf{M}_{R_O} = \mathbf{r}_1 \times \mathbf{F}_1 + \mathbf{r}_2 \times \mathbf{F}_2 \\ &= \begin{vmatrix} \mathbf{i} & \mathbf{j} & \mathbf{k} \\ 2 & 6 & 0 \\ 0 & 0 & 6.00 \end{vmatrix} + \begin{vmatrix} \mathbf{i} & \mathbf{j} & \mathbf{k} \\ 4 & 0 & 0 \\ -1.768 & 3.062 & 3.536 \end{vmatrix} \\ &= \{36.0\mathbf{i} - 26.1\mathbf{j} + 12.2\mathbf{k}\} \text{ kN} \cdot \text{m} \quad \text{Ans} \end{aligned}$$

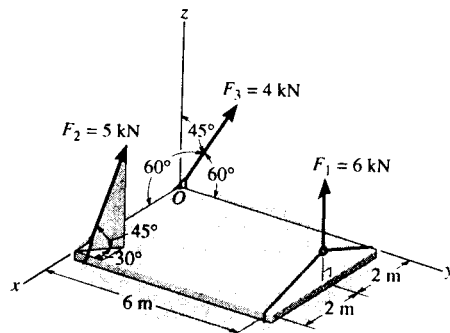

***4-132.** A biomechanical model of the lumber region of the human trunk is shown. The forces acting in the four muscle groups consist of $F_R = 35\text{ N}$ for the rectus, $F_O = 45\text{ N}$ for the oblique, $F_L = 23\text{ N}$ for the lumbar latissimus dorsi, and $F_E = 32\text{ N}$ for the erector spinae. These loadings are symmetric with respect to the y - z plane. Replace this system of parallel forces by an equivalent force and couple moment acting at the spine, point O . Express the results in Cartesian vector form.

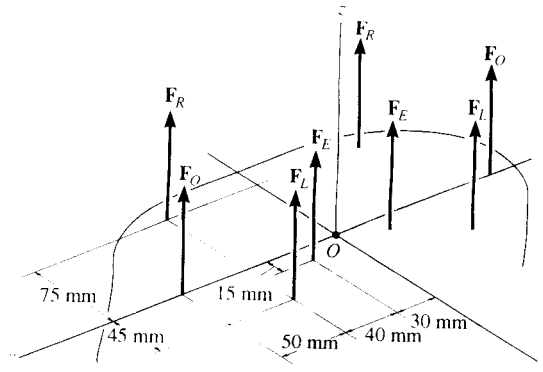

$$F_R = \Sigma F_z; \quad F_R = \{ 2(35 + 45 + 23 + 32)\mathbf{k} \} = \{ 270\mathbf{k} \} \text{ N} \quad \text{Ans}$$

$$M_{RO} = \Sigma M_O; \quad M_{RO} = [-2(35)(0.075) + 2(32)(0.015) + 2(23)(0.045)]\mathbf{i}$$

$$M_{RO} = \{-2.22\mathbf{i}\} \text{ N}\cdot\text{m} \quad \text{Ans}$$

4-133. The building slab is subjected to four parallel column loadings. Determine the equivalent resultant force and specify its location (x, y) on the slab. Take $F_1 = 30\text{ kN}$, $F_2 = 40\text{ kN}$.

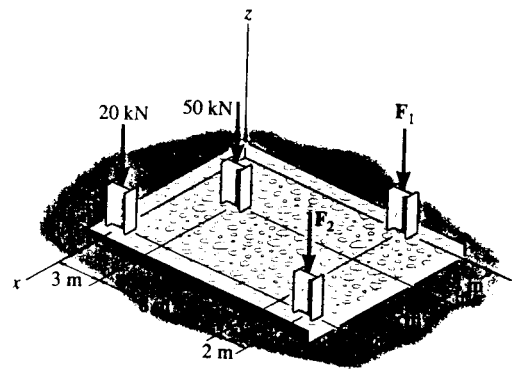

$$+\uparrow F_R = \Sigma F_z; \quad F_R = -30 - 50 - 40 - 20 = -140\text{ kN} = 140\text{ kN} \downarrow \quad \text{Ans}$$

$$(M_R)_x = \Sigma M_x; \quad -140y = -50(3) - 30(11) - 40(13)$$

$$y = 7.14\text{ m}$$

$$(M_R)_y = \Sigma M_y; \quad 140x = 50(4) + 20(10) + 40(10)$$

$$x = 5.71\text{ m}$$

4-134. The building slab is subjected to four parallel column loadings. Determine the equivalent resultant force and specify its location (x, y) on the slab. Take $F_1 = 20\text{ kN}$, $F_2 = 50\text{ kN}$.

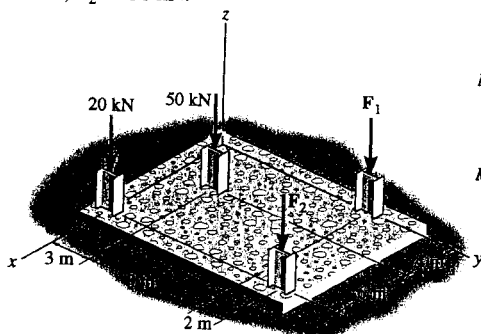

$$+\downarrow F_R = \Sigma F_z; \quad F_R = 20 + 50 + 20 + 50 = 140\text{ kN} \quad \text{Ans}$$

$$M_{ROy} = \Sigma M_y; \quad 140(x) = (50)(4) + 20(10) + 50(10)$$

$$x = 6.43\text{ m}$$

Ans

$$M_{ROx} = \Sigma M_x; \quad -140(y) = -(50)(3) - 20(11) - 50(13)$$

$$y = 7.29\text{ m}$$

Ans

*4-135. Replace the two wrenches and the force, acting on the pipe assembly, by an equivalent resultant force and couple moment at point O .

Force And Moment Vectors :

$$F_1 = \{300\mathbf{k}\} \text{ N} \quad F_3 = \{100\mathbf{j}\} \text{ N}$$

$$F_2 = 200\{\cos 45^\circ\mathbf{i} - \sin 45^\circ\mathbf{k}\} \text{ N} \\ = \{141.42\mathbf{i} - 141.42\mathbf{k}\} \text{ N}$$

$$M_1 = \{100\mathbf{k}\} \text{ N} \cdot \text{m}$$

$$M_2 = 180\{\cos 45^\circ\mathbf{i} - \sin 45^\circ\mathbf{k}\} \text{ N} \cdot \text{m} \\ = \{127.28\mathbf{i} - 127.28\mathbf{k}\} \text{ N} \cdot \text{m}$$

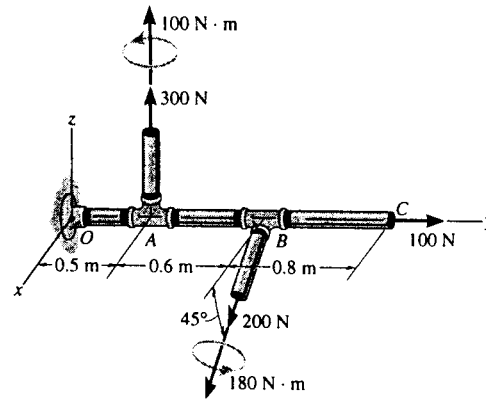

Equivalent Force and Couple Moment At Point O :

$$F_R = \Sigma F; \quad F_R = F_1 + F_2 + F_3 \\ = 141.42\mathbf{i} + 100.0\mathbf{j} + (300 - 141.42)\mathbf{k} \\ = \{141\mathbf{i} + 100\mathbf{j} + 159\mathbf{k}\} \text{ N}$$

Ans

The position vectors are $r_1 = \{0.5\mathbf{j}\} \text{ m}$ and $r_2 = \{1.1\mathbf{j}\} \text{ m}$.

$$M_{R_O} = \Sigma M_{O_i}; \quad M_{R_O} = r_1 \times F_1 + r_2 \times F_2 + M_1 + M_2$$

$$= \begin{vmatrix} \mathbf{i} & \mathbf{j} & \mathbf{k} \\ 0 & 0.5 & 0 \\ 0 & 0 & 300 \end{vmatrix} \\ + \begin{vmatrix} \mathbf{i} & \mathbf{j} & \mathbf{k} \\ 0 & 1.1 & 0 \\ 141.42 & 0 & -141.42 \end{vmatrix}$$

$$+ 100\mathbf{k} + 127.28\mathbf{i} - 127.28\mathbf{k}$$

$$= \{122\mathbf{i} - 183\mathbf{k}\} \text{ N} \cdot \text{m}$$

Ans

*4-136. The three forces acting on the block each have a magnitude of 10 lb. Replace this system by a wrench and specify the point where the wrench intersects the z axis, measured from point O .

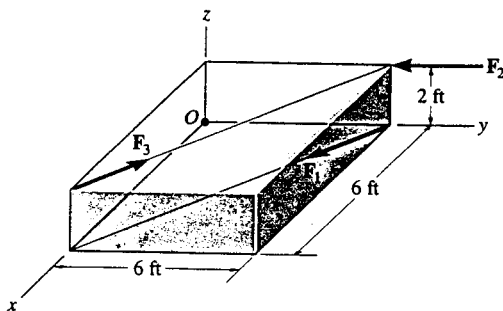

$$F_R = \{-10\mathbf{j}\} \text{ lb}$$

$$M_O = (6\mathbf{j} + 2\mathbf{k}) \times (-10\mathbf{j}) + 2(10)(-0.707\mathbf{i} - 0.707\mathbf{j}) \\ = \{5.858\mathbf{i} - 14.14\mathbf{j}\} \text{ lb} \cdot \text{ft}$$

Require

$$z = \frac{5.858}{10} = 0.586 \text{ ft} \quad \text{Ans}$$

$$F_w = \{-10\mathbf{j}\} \text{ lb} \quad \text{Ans}$$

$$M_w = \{-14.1\mathbf{j}\} \text{ lb} \cdot \text{ft} \quad \text{Ans}$$

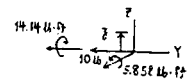

4-137. Replace the three forces acting on the plate by a wrench. Specify the magnitude of the force and couple moment for the wrench and the point $P(x, y)$ where its line of action intersects the plate.

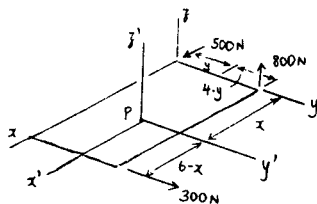
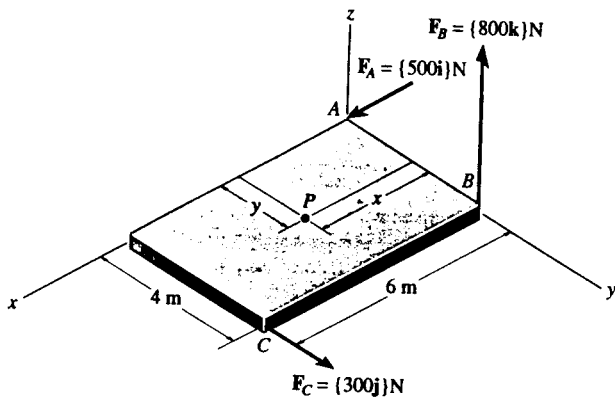

$$\mathbf{F}_R = \{500\mathbf{i} + 300\mathbf{j} + 800\mathbf{k}\} \text{ N}$$

$$F_R = \sqrt{(500)^2 + (300)^2 + (800)^2} = 990 \text{ N} \quad \text{Ans}$$

$$\mathbf{u}_{FR} = \{0.5051\mathbf{i} + 0.3030\mathbf{j} + 0.8081\mathbf{k}\}$$

$$M_{R_x} = \Sigma M_x; \quad M_{R_x} = 800(4-y)$$

$$M_{R_y} = \Sigma M_y; \quad M_{R_y} = 800x$$

$$M_{R_z} = \Sigma M_z; \quad M_{R_z} = 500y + 300(6-x)$$

Since M_R also acts in the direction of \mathbf{u}_{FR} ,

$$M_R(0.5051) = 800(4-y)$$

$$M_R(0.3030) = 800x$$

$$M_R(0.8081) = 500y + 300(6-x)$$

$$M_R = 3.07 \text{ kN}\cdot\text{m} \quad \text{Ans}$$

$$x = 1.16 \text{ m} \quad \text{Ans}$$

$$y = 2.06 \text{ m} \quad \text{Ans}$$

4-138. Replace the three forces acting on the plate by a wrench. Specify the magnitude of the force and couple moment for the wrench and the point $P(y, z)$ where its line of action intersects the plate.

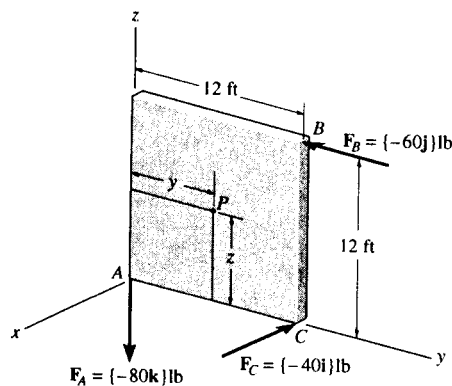

Resultant Force Vector :

$$\mathbf{F}_R = \{-40\mathbf{i} - 60\mathbf{j} - 80\mathbf{k}\} \text{ lb}$$

$$F_R = \sqrt{(-40)^2 + (-60)^2 + (-80)^2} = 107.70 \text{ lb} = 108 \text{ lb} \quad \text{Ans}$$

$$\mathbf{u}_{FR} = \frac{-40\mathbf{i} - 60\mathbf{j} - 80\mathbf{k}}{107.70} = -0.3714\mathbf{i} - 0.5571\mathbf{j} - 0.7428\mathbf{k}$$

Resultant Moment: The line of action of M_R of the wrench is parallel to the line of action of \mathbf{F}_R . Assume that both M_R and \mathbf{F}_R have the same sense. Therefore, $\mathbf{u}_{M_R} = -0.3714\mathbf{i} - 0.5571\mathbf{j} - 0.7428\mathbf{k}$.

$$(M_R)_x = \Sigma M_x; \quad -0.3714M_R = 60(12-z) + 80y \quad [1]$$

$$(M_R)_y = \Sigma M_y; \quad -0.5571M_R = 40z \quad [2]$$

$$(M_R)_z = \Sigma M_z; \quad -0.7428M_R = 40(12-y) \quad [3]$$

Solving Eqs. [1], [2], and [3] yields :

$$M_R = -624 \text{ lb}\cdot\text{ft} \quad z = 8.69 \text{ ft} \quad y = 0.414 \text{ ft} \quad \text{Ans}$$

The negative sign indicates that the line of action for M_R is directed in the opposite sense to that of \mathbf{F}_R .

4-139. The loading on the bookshelf is distributed. Determine the magnitude of the equivalent resultant location, measured from point O .

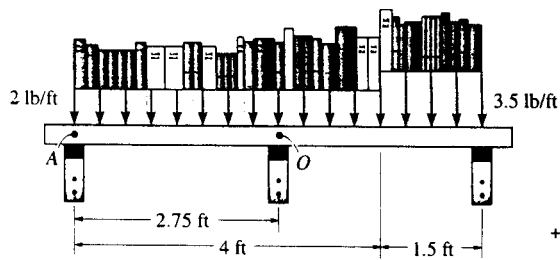

$$+\downarrow F_{Ro} = \Sigma F; \quad F_{Ro} = 8 + 5.25 = 13.25 = 13.2 \text{ lb } \downarrow$$

$$\zeta + M_{Ro} = \Sigma M_O; \quad 13.25x = 5.25(0.75 + 1.25) - 8(2 - 1.25)$$

$$x = 0.340 \text{ ft}$$

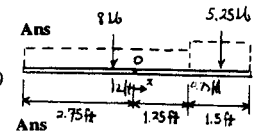

*4-140. The masonry support creates the loading distribution acting on the end of the beam. Simplify this load to a single resultant force and specify its location measured from point O .

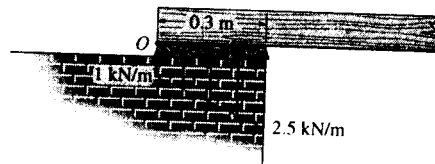

Equivalent Resultant Force :

$$+\uparrow F_R = \Sigma F_y; \quad F_R = 0.300 + 0.225 = 0.525 \text{ kN } \uparrow \quad \text{Ans}$$

Location of Equivalent Resultant Force :

$$\zeta + (M_R)_O = \Sigma M_O; \quad 0.525(d) = 0.300(0.15) + 0.225(0.2)$$

$$d = 0.171 \text{ m} \quad \text{Ans}$$

4-141. Replace the loading by an equivalent force and couple moment acting at point O .

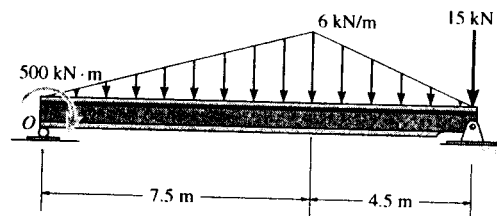

$$+\uparrow F_R = \Sigma F_y; \quad F_R = -22.5 - 13.5 - 15.0$$

$$= -51.0 \text{ kN} = 51.0 \text{ kN } \downarrow \quad \text{Ans}$$

$$\zeta + M_{Ro} = \Sigma M_O; \quad M_{Ro} = -500 - 22.5(5) - 13.5(9) - 15(12)$$

$$= -914 \text{ kN} \cdot \text{m}$$

$$= 914 \text{ kN} \cdot \text{m} \text{ (Clockwise)} \quad \text{Ans}$$

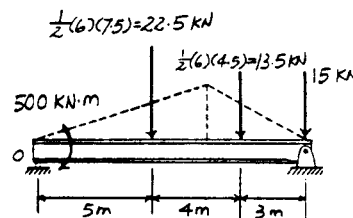

4-142. Replace the loading by a single resultant force, and specify the location of the force on the beam measured from point O .

Equivalent Resultant Force:

$$+\uparrow F_R = \Sigma F_y; \quad -F_R = -22.5 - 13.5 - 15$$

$$F_R = 51.0 \text{ kN} \downarrow \quad \text{Ans}$$

Location of Equivalent Resultant Force:

$$(+M_R)_O = \Sigma M_O; \quad -51.0(d) = -500 - 22.5(5) - 13.5(9) - 15(12)$$

$$d = 17.9 \text{ m} \quad \text{Ans}$$

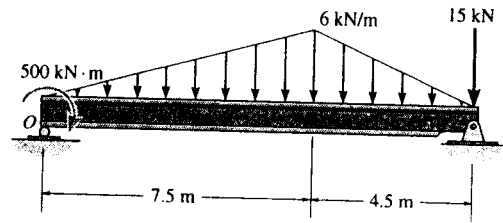

4-143. The column is used to support the floor which exerts a force of 3000 lb on the top of the column. The effect of soil pressure along its side is distributed as shown. Replace this loading by an equivalent resultant force and specify where it acts along the column, measured from its base A .

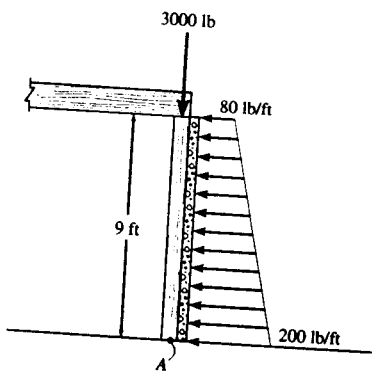

$$+\leftarrow \Sigma F_{Rx} = \Sigma F_x; \quad F_{Rx} = 720 + 540 = 1260 \text{ lb}$$

$$+\downarrow F_{Ry} = \Sigma F_y; \quad F_{Ry} = 3000 \text{ lb}$$

$$F_R = \sqrt{(1260)^2 + (3000)^2} = 3254 \text{ lb}$$

$$F_R = 3.25 \text{ kip} \quad \text{Ans}$$

$$\theta = \tan^{-1} \left[\frac{3000}{1260} \right] = 67.2^\circ \quad \text{Ans}$$

$$(+M_{RA}) = \Sigma M_A; \quad 1260x = 540(3) + 720(4.5)$$

$$x = 3.86 \text{ ft} \quad \text{Ans}$$

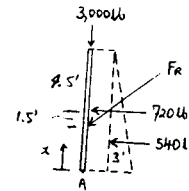

*4-144. Replace the loading by an equivalent force and couple moment acting at point O .

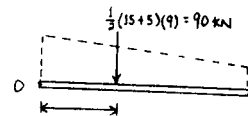
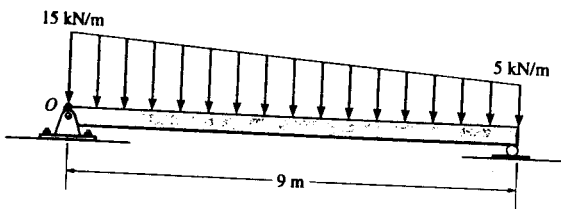

$$+\downarrow F_R = \Sigma F; \quad F_R = 90 \text{ kN} \downarrow$$

Ans

$$(+M_{RO}) = \Sigma M_O; \quad M_{RO} = 90(3.75) = 338 \text{ kN}\cdot\text{m}$$

Ans

4-145. Replace the distributed loading by an equivalent resultant force, and specify its location on the beam, measured from the pin at C .

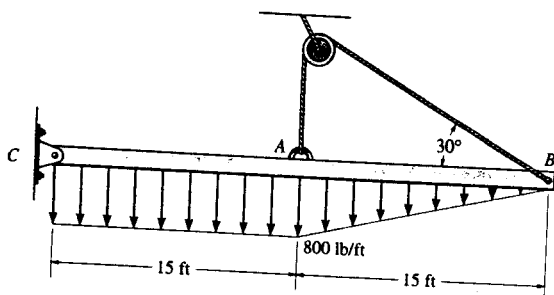

$$+\downarrow F_R = \Sigma F; \quad F_R = 12000 + 6000 = 18000 \text{ lb}$$

$$F_R = 18.0 \text{ kip} \downarrow \quad \text{Ans}$$

$$(+M_{RC}) = \Sigma M_C; \quad 18000x = 12000(7.5) + 6000(20)$$

$$x = 11.7 \text{ ft} \quad \text{Ans}$$

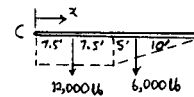

4-146. Replace the loading by an equivalent force and couple moment acting at point O .

Equivalent Force and Couple Moment At Point O :

$$+\uparrow F_R = \Sigma F_y; \quad F_R = -800 - 300 \\ = -1100 \text{ N} = 1.10 \text{ kN} \downarrow \quad \text{Ans}$$

$$+ M_{R_o} = \Sigma M_o; \quad M_{R_o} = -800(2) - 300(5) \\ = -3100 \text{ N} \cdot \text{m} \\ = 3.10 \text{ kN} \cdot \text{m} \text{ (Clockwise)} \quad \text{Ans}$$

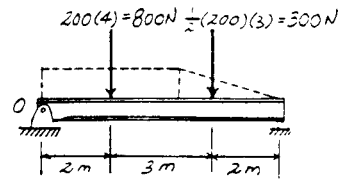
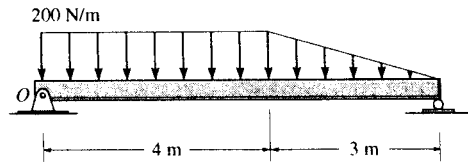

*4-147. The bricks on top of the beam and the supports at the bottom create the distributed loading shown in the second figure. Determine the required intensity w and dimension d of the right support so that the resultant force and couple moment about point A of the system are both zero.

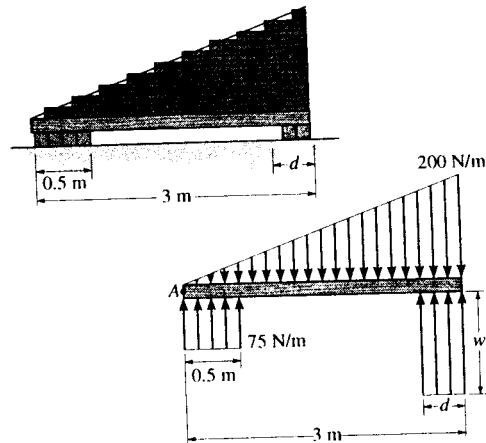

Require $F_R = 0$.

$$+\uparrow F_R = \Sigma F_y; \quad 0 = wd + 37.5 - 300 \\ wd = 262.5 \quad [1]$$

Require $M_{R_A} = 0$.

$$\curvearrowright + M_{R_A} = \Sigma M_A; \quad 0 = 37.5(0.25) + wd\left(3 - \frac{d}{2}\right) - 300(2) \\ 3wd - \frac{wd^2}{2} = 590.625 \quad [2]$$

Solving Eqs. [1] and [2] yields

$$d = 1.50 \text{ m} \quad w = 175 \text{ N/m} \quad \text{Ans}$$

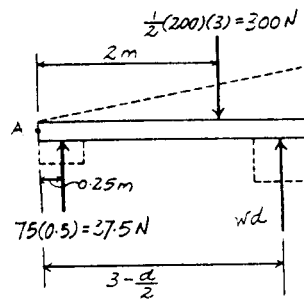

***4-148.** Replace the distributed loading by an equivalent resultant force and specify its location, measured from point A.

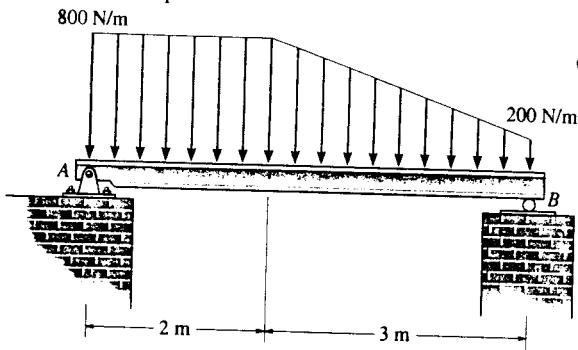

$$+\downarrow F_R = \Sigma F; \quad F_R = 1600 + 900 + 600 = 3100 \text{ N}$$

$$F_R = 3.10 \text{ kN} \downarrow \quad \text{Ans}$$

$$\curvearrowright + M_{RA} = \Sigma M_A; \quad x(3100) = 1600(1) + 900(3) + 600(3.5)$$

$$x = 2.06 \text{ m} \quad \text{Ans}$$

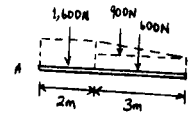

4-149. The distribution of soil loading on the bottom of a building slab is shown. Replace this loading by an equivalent resultant force and specify its location, measured from point O.

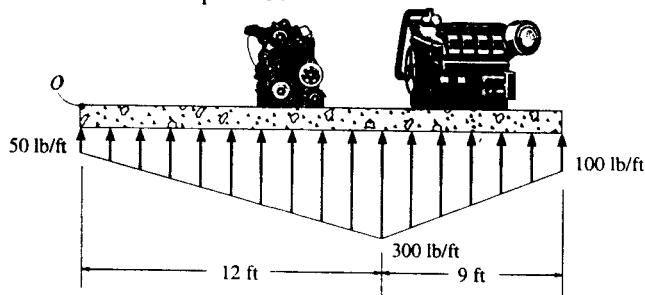

$$+\uparrow F_R = \Sigma F; \quad F_R = 50(12) + \frac{1}{2}(250)(12) + \frac{1}{2}(200)(9) + 100(9)$$

$$= 3900 \text{ lb} = 3.90 \text{ kip} \uparrow \quad \text{Ans}$$

$$\curvearrowleft + M_{RO} = \Sigma M_O; \quad 3900(d) = 50(12)(6) + \frac{1}{2}(250)(12)(8) + \frac{1}{2}(200)(9)(15) + 100(9)(16.5)$$

$$d = 11.3 \text{ ft} \quad \text{Ans}$$

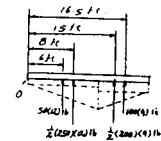

4-150. The beam is subjected to the distributed loading. Determine the length b of the uniform load and its position a on the beam such that the resultant force and couple moment acting on the beam are zero.

Require $F_R = 0$.

$$+\uparrow F_R = \Sigma F_y; \quad 0 = 180 - 20b$$

$$b = 9.00 \text{ ft} \quad \text{Ans}$$

Require $M_{RA} = 0$. Using the result $b = 9.00$ ft, we have

$$\curvearrowleft + M_{RA} = \Sigma M_A; \quad 0 = 180(12) - 20(9.00)\left(a + \frac{9.00}{2}\right)$$

$$a = 7.50 \text{ ft} \quad \text{Ans}$$

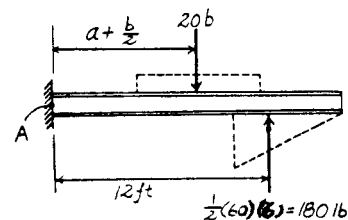
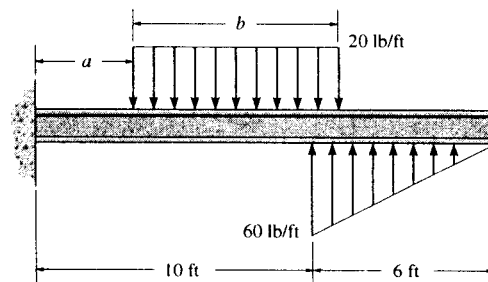

***4-148.** Replace the distributed loading by an equivalent resultant force and specify its location, measured from point A.

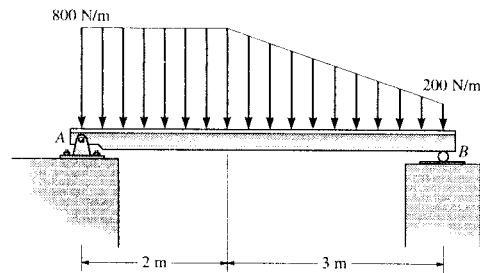

$$+\downarrow F_R = \Sigma F; \quad F_R = 1600 + 900 + 600 = 3100 \text{ N}$$

$$F_R = 3.10 \text{ kN} \downarrow \quad \text{Ans}$$

$$\curvearrowleft +M_{RA} = \Sigma M_A; \quad x(3100) = 1600(1) + 900(3) + 600(3.5)$$

$$x = 2.06 \text{ m}$$

Ans

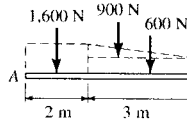

4-149. The distribution of soil loading on the bottom of a building slab is shown. Replace this loading by an equivalent resultant force and specify its location, measured from point O.

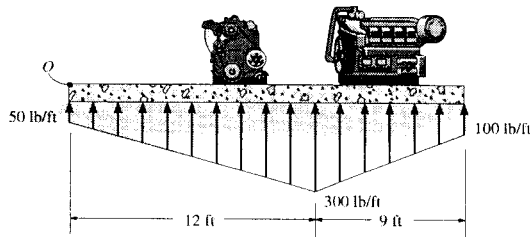

$$+\uparrow F_R = \Sigma F_y; \quad F_R = 50(12) + \frac{1}{2}(250)(12)$$

$$+ \frac{1}{2}(200)(9) + 100(9)$$

$$= 3900 \text{ lb} = 3.90 \text{ kip} \uparrow$$

Ans

$$\curvearrowleft +M_{R_O} = \Sigma M_O; \quad 3900(d) = 50(12)(6) + \frac{1}{2}(250)(12)(8)$$

$$+ \frac{1}{2}(200)(9)(15) + 100(9)(16.5)$$

$$d = 11.3 \text{ ft}$$

Ans

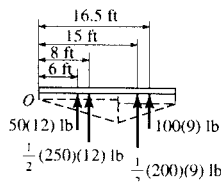

4-150. The beam is subjected to the distributed loading. Determine the length b of the uniform load and its position a on the beam such that the resultant force and couple moment acting on the beam are zero.

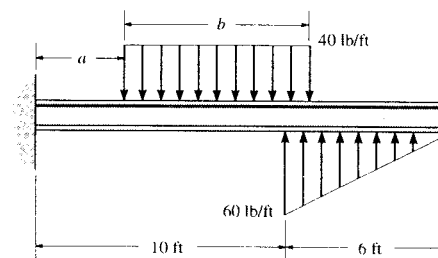

Require $F_R = 0$.

$$+\uparrow F_R = \Sigma F_y; \quad 0 = 180 - 40b$$

$$b = 4.50 \text{ ft}$$

Ans

Require $M_{R_A} = 0$. Using the result $b = 4.50 \text{ ft}$, we have

$$\curvearrowleft +M_{R_A} = \Sigma M_A; \quad 0 = 180(12) - 40(4.50) \left(a + \frac{4.50}{2} \right)$$

$$a = 9.75 \text{ ft}$$

Ans

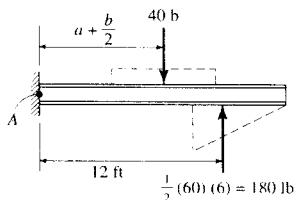

4-151. Replace the loading by an equivalent resultant force and specify its location on the beam, measured from point B.

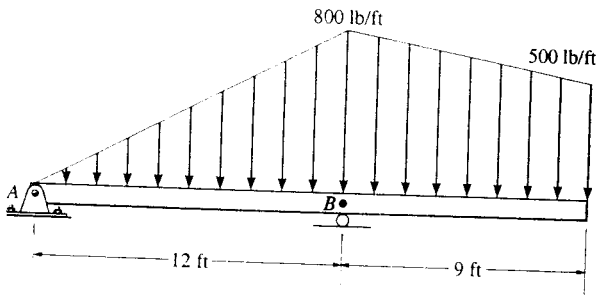

$$+\downarrow F_R = \Sigma F; \quad F_R = 4800 + 1350 + 4500 = 10\,650 \text{ lb}$$

$$F_R = 10.6 \text{ kip} \downarrow \quad \text{Ans}$$

$$\curvearrowleft + M_{RB} = \Sigma M_B; \quad 10\,650x = -4800(4) + 1350(3) + 4500(4.5)$$

$$x = 0.479 \text{ ft} \quad \text{Ans}$$

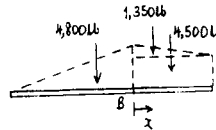

*4-152. Replace the distributed loading by an equivalent resultant force and specify where its line of action intersects member AB, measured from A.

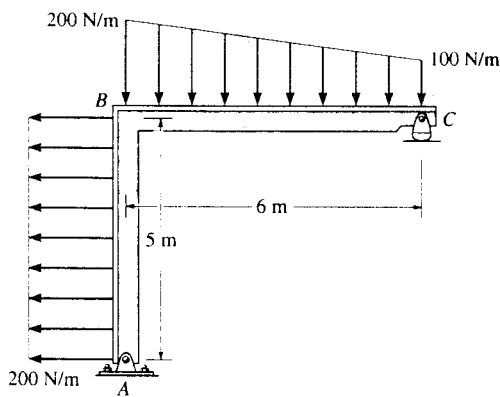

$$\curvearrowleft - \Sigma F_{Rx} = \Sigma F_x; \quad F_{Rx} = 1000 \text{ N}$$

$$+\downarrow F_{Ry} = \Sigma F_y; \quad F_{Ry} = 900 \text{ N}$$

$$F_R = \sqrt{(1000)^2 + (900)^2} = 1345 \text{ N}$$

$$F_R = 1.35 \text{ kN} \quad \text{Ans}$$

$$\theta = \tan^{-1}\left[\frac{900}{1000}\right] = 42.0^\circ \text{ } \curvearrowright \text{ Ans}$$

$$\curvearrowleft + M_{RA} = \Sigma M_A; \quad 1000y = 1000(2.5) - 300(2) - 600(3)$$

$$y = 0.1 \text{ m} \quad \text{Ans}$$

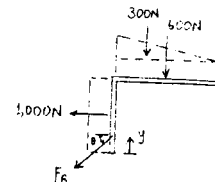

4-153. Replace the distributed loading by an equivalent resultant force and specify where its line of action intersects member BC, measured from C.

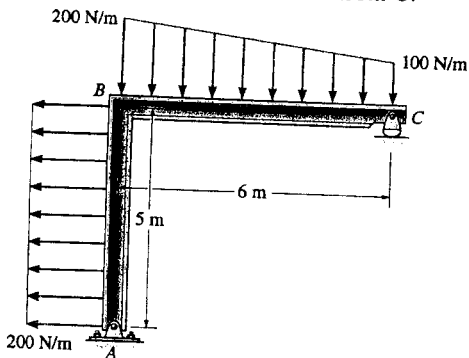

$$\curvearrowleft - \Sigma F_{Rx} = \Sigma F_x; \quad F_{Rx} = 1000 \text{ N}$$

$$+\downarrow F_{Ry} = \Sigma F_y; \quad F_{Ry} = 900 \text{ N}$$

$$F_R = \sqrt{(1000)^2 + (900)^2} = 1345 \text{ N}$$

$$F_R = 1.35 \text{ kN} \quad \text{Ans}$$

$$\theta = \tan^{-1}\left[\frac{900}{1000}\right] = 42.0^\circ \text{ } \curvearrowright \text{ Ans}$$

$$\curvearrowleft + M_{RC} = \Sigma M_C; \quad 900x = 600(3) + 300(4) - 1000(2.5)$$

$$x = 0.556 \text{ m} \quad \text{Ans}$$

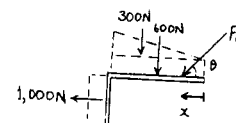

4-154. Replace the loading by an equivalent resultant force and couple moment acting at point O .

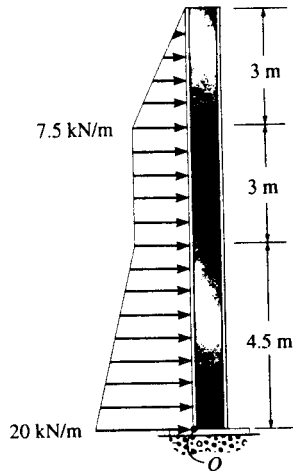

$$\begin{aligned} \rightarrow F_R = \Sigma F_x: \quad F_R &= \frac{1}{2}(12.5)(4.5) + 7.5(4.5) + 7.5(3) + \frac{1}{2}(7.5)(3) \\ &= 95.6 \text{ kN} \rightarrow \quad \text{Ans} \\ \curvearrowright +M_{R_o} = \Sigma M_o: \quad M_{R_o} &= -\frac{1}{2}(12.5)(4.5)(1.5) - 7.5(4.5)(2.25) - 7.5(3)(6) - \frac{1}{2}(7.5)(3)(8.5) \\ &= -349 \text{ kN} \cdot \text{m} = 349 \text{ kN} \cdot \text{m} \quad \text{Ans} \end{aligned}$$

4-155. Wet concrete exerts a pressure distribution along the wall of the form. Determine the resultant force of this distribution and specify the height h where the bracing strut should be placed so that it lies through the line of action of the resultant force. The wall has a width of 5 m.

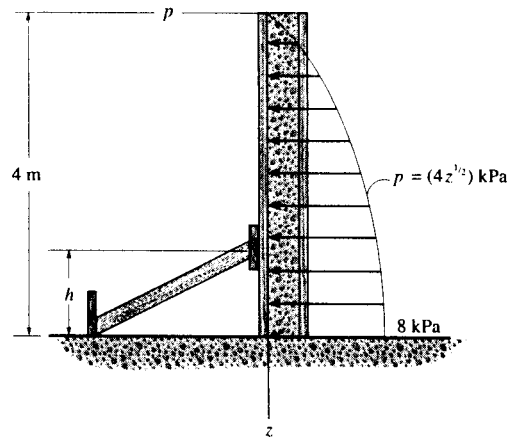

Equivalent Resultant Force:

$$\begin{aligned} \rightarrow F_R = \Sigma F_x: \quad -F_R &= -\int_A dA = -\int_0^4 w dz \\ F_R &= \int_0^{4\text{m}} (20z^{1/2})(10^3) dz \\ &= 106.67(10^3) \text{ N} = 107 \text{ kN} \leftarrow \quad \text{Ans} \end{aligned}$$

Location of Equivalent Resultant Force:

$$\begin{aligned} \bar{z} &= \frac{\int_A z dA}{\int_A dA} = \frac{\int_0^4 zw dz}{\int_0^4 w dz} \\ &= \frac{\int_0^{4\text{m}} z[(20z^{1/2})(10^3)] dz}{\int_0^{4\text{m}} (20z^{1/2})(10^3) dz} \\ &= \frac{\int_0^{4\text{m}} (20z^{3/2})(10^3) dz}{\int_0^{4\text{m}} (20z^{1/2})(10^3) dz} \\ &= 2.40 \text{ m} \end{aligned}$$

Thus, $h = 4 - \bar{z} = 4 - 2.40 = 1.60 \text{ m}$ Ans

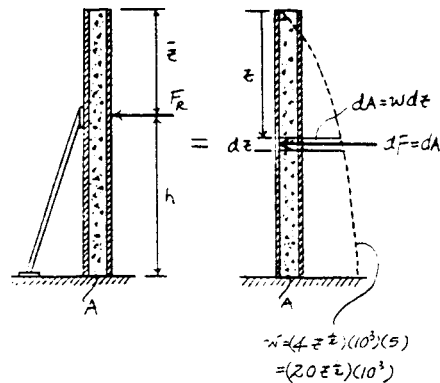

*4-156. Wind has blown sand over a platform such that the intensity of the load can be approximated by the function $w = (0.5x^3)$ N/m. Simplify this distributed loading to an equivalent resultant force and specify the magnitude and location of the force, measured from A.

$$dA = w dx$$

$$F_R = \int dA = \int_0^{10} \frac{1}{2} x^3 dx$$

$$= \left[\frac{1}{8} x^4 \right]_0^{10}$$

$$= 1250 \text{ N}$$

$$F_R = 1.25 \text{ kN}$$

Ans

$$\int \bar{x} dA = \int_0^{10} \frac{1}{2} x^4 dx$$

$$= \left[\frac{1}{10} x^5 \right]_0^{10}$$

$$= 10\,000 \text{ N}\cdot\text{m}$$

$$\bar{x} = \frac{10\,000}{1250} = 8.00 \text{ m}$$

Ans

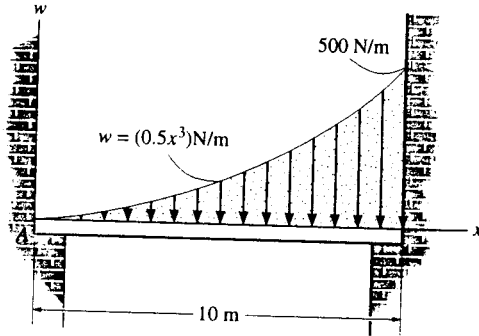
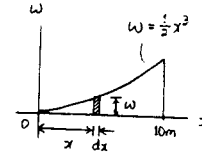

4-157. Replace the loading by an equivalent force and couple moment acting at point O.

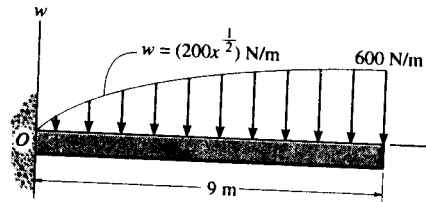

Equivalent Resultant Force And Moment At Point O :

$$+ \uparrow F_R = \Sigma F_y; \quad F_R = - \int_A dA = - \int_0^9 w dx$$

$$F_R = - \int_0^9 (200x^{1/2}) dx$$

$$= -3600 \text{ N} = 3.60 \text{ kN} \downarrow$$

Ans

$$(+ M_{R_o} = \Sigma M_o; \quad M_{R_o} = - \int_0^9 x w dx$$

$$= - \int_0^9 x (200x^{1/2}) dx$$

$$= - \int_0^9 (200x^{3/2}) dx$$

$$= -19\,440 \text{ N}\cdot\text{m}$$

$$= 19.4 \text{ kN}\cdot\text{m (Clockwise)}$$

Ans

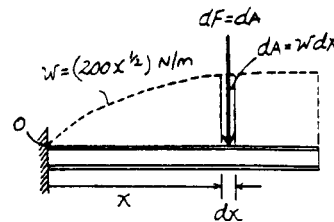

***4-158.** The lifting force along the wing of a jet aircraft consists of a uniform distribution along AB , and a semiparabolic distribution along BC with origin at B . Replace this loading by a single resultant force and specify its location measured from point A .

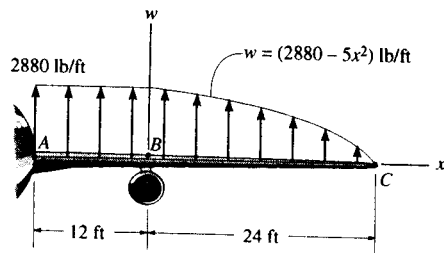

Equivalent Resultant Force :

$$\begin{aligned}
 + \uparrow F_R = \Sigma F_y; \quad F_R &= 34560 + \int_0^{24} w dx \\
 F_R &= 34560 + \int_0^{24} (2880 - 5x^2) dx \\
 &= 80640 \text{ lb} = 80.6 \text{ kip} \uparrow
 \end{aligned}$$

Ans

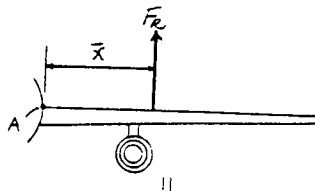

Location of Equivalent Resultant Force :

$$\begin{aligned}
 (+ M_{R_A} = \Sigma M_A; \\
 80640 \bar{x} &= 34560(6) + \int_0^{24} (x+12) w dx \\
 80640 \bar{x} &= 207360 + \int_0^{24} (x+12)(2880 - 5x^2) dx \\
 80640 \bar{x} &= 207360 + \int_0^{24} (-5x^3 - 60x^2 + 2880x + 34560) dx \\
 \bar{x} &= 14.6 \text{ ft}
 \end{aligned}$$

Ans

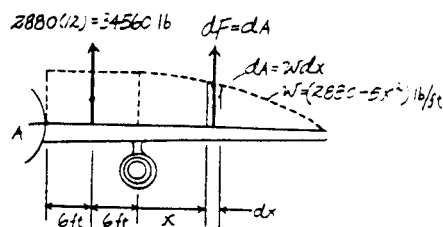

4-159. Determine the magnitude of the equivalent resultant force of the distributed load and specify its location on the beam measured from point A .

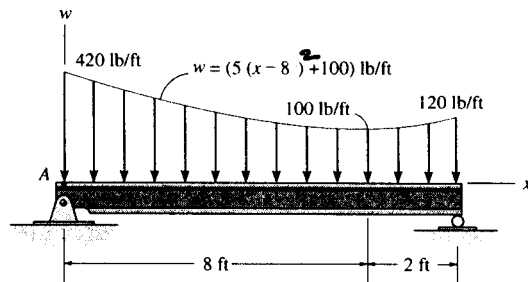

Equivalent Resultant Force :

$$\begin{aligned}
 + \uparrow F_R = \Sigma F_y; \quad -F_R &= - \int_A dA = - \int_0^{10} w dx \\
 F_R &= \int_0^{10} [5(x-8)^2 + 100] dx \\
 &= 1866.67 \text{ lb} = 1.87 \text{ kip} \downarrow
 \end{aligned}$$

Ans

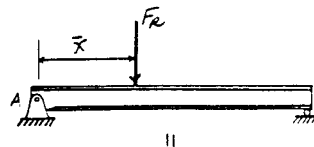

Location of Equivalent Resultant Force :

$$\begin{aligned}
 \bar{x} &= \frac{\int_A x dA}{\int_A dA} = \frac{\int_0^{10} x w dx}{\int_0^{10} w dx} \\
 &= \frac{\int_0^{10} x [5(x-8)^2 + 100] dx}{\int_0^{10} [5(x-8)^2 + 100] dx} \\
 &= \frac{\int_0^{10} (5x^3 - 80x^2 + 420x) dx}{\int_0^{10} [5(x-8)^2 + 100] dx} \\
 &= 3.66 \text{ ft}
 \end{aligned}$$

Ans

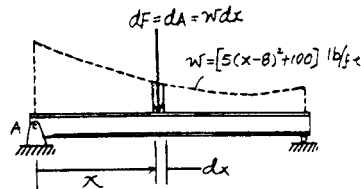

***4-160.** Determine the equivalent resultant force of the distributed loading and its location, measured from point A. Evaluate the integrals using Simpson's rule.

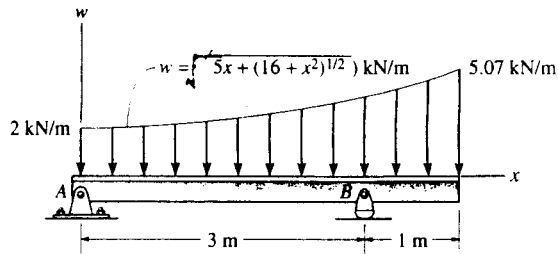

$$F_R = \int w dx = \int_0^4 \sqrt{5x + (16 + x^2)^{1/2}} dx$$

$$F_R = 14.9 \text{ kN} \quad \text{Ans}$$

$$\int_0^4 \bar{x} dF = \int_0^4 (x) \sqrt{5x + (16 + x^2)^{1/2}} dx$$

$$= 33.74 \text{ kN}\cdot\text{m}$$

$$\bar{x} = \frac{33.74}{14.9} = 2.27 \text{ m} \quad \text{Ans}$$

4-161. Determine the coordinate direction angles α , β , γ of F , which is applied to the end A of the pipe assembly, so that the moment of F about O is zero.

Require $M_O = 0$. This happens when force F is directed along line OA either from point O to A or from point A to O . The unit vectors u_{OA} and u_{AO} are

$$u_{OA} = \frac{(6-0)\mathbf{i} + (14-0)\mathbf{j} + (10-0)\mathbf{k}}{\sqrt{(6-0)^2 + (14-0)^2 + (10-0)^2}}$$

$$= 0.3293\mathbf{i} + 0.7683\mathbf{j} + 0.5488\mathbf{k}$$

Thus,

$$\alpha = \cos^{-1} 0.3293 = 70.8^\circ \quad \text{Ans}$$

$$\beta = \cos^{-1} 0.7683 = 39.8^\circ \quad \text{Ans}$$

$$\gamma = \cos^{-1} 0.5488 = 56.7^\circ \quad \text{Ans}$$

$$u_{AO} = \frac{(0-6)\mathbf{i} + (0-14)\mathbf{j} + (0-10)\mathbf{k}}{\sqrt{(0-6)^2 + (0-14)^2 + (0-10)^2}}$$

$$= -0.3293\mathbf{i} - 0.7683\mathbf{j} - 0.5488\mathbf{k}$$

Thus,

$$\alpha = \cos^{-1} (-0.3293) = 109^\circ \quad \text{Ans}$$

$$\beta = \cos^{-1} (-0.7683) = 140^\circ \quad \text{Ans}$$

$$\gamma = \cos^{-1} (-0.5488) = 123^\circ \quad \text{Ans}$$

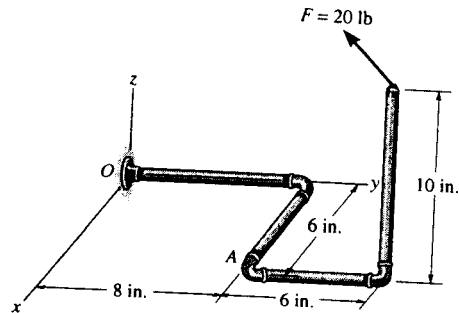

4-162. Determine the moment of the force F about point O . The force has coordinate direction angles $\alpha = 60^\circ$, $\beta = 120^\circ$, $\gamma = 45^\circ$. Express the result as a Cartesian vector.

Position Vector And Force Vectors :

$$r_{OA} = \{(6-0)\mathbf{i} + (14-0)\mathbf{j} + (10-0)\mathbf{k}\} \text{ in.}$$

$$= \{6\mathbf{i} + 14\mathbf{j} + 10\mathbf{k}\} \text{ in.}$$

$$F = 20(\cos 60^\circ\mathbf{i} + \cos 120^\circ\mathbf{j} + \cos 45^\circ\mathbf{k}) \text{ lb}$$

$$= \{10.0\mathbf{i} - 10.0\mathbf{j} + 14.142\mathbf{k}\} \text{ lb}$$

Moment of Force F About Point O : Applying Eq. 4-7, we have

$$M_O = r_{OA} \times F$$

$$= \begin{vmatrix} \mathbf{i} & \mathbf{j} & \mathbf{k} \\ 6 & 14 & 10 \\ 10.0 & -10.0 & 14.142 \end{vmatrix}$$

$$= \{298\mathbf{i} + 15.1\mathbf{j} - 200\mathbf{k}\} \text{ lb}\cdot\text{in} \quad \text{Ans}$$

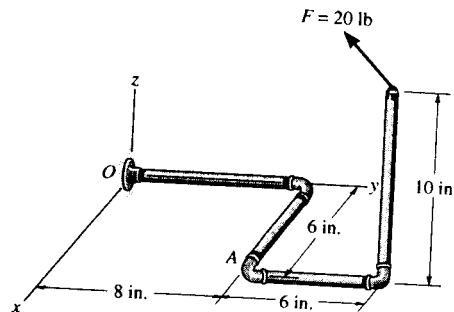

4-163. If it takes a force of $F = 125$ lb to pull the nail out, determine the smallest vertical force P that must be applied to the handle of the crowbar. *Hint:* This requires the moment of F about point A to be equal to the moment of P about A . Why?

$$\uparrow +M_F = 125(\sin 60^\circ)(3) = 324.7595 \text{ lb} \cdot \text{in.}$$

$$\uparrow +M_P = P(14 \cos 20^\circ + 1.5 \sin 20^\circ) = M_F = 324.7595 \text{ lb} \cdot \text{in.}$$

$$P = 23.8 \text{ lb}$$

Ans

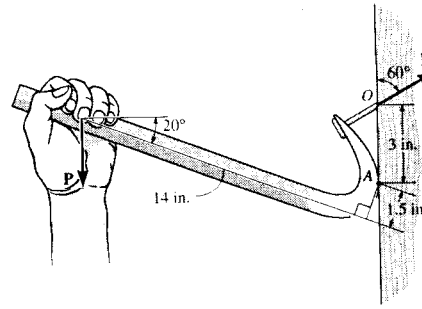

***4-164.** Determine the moment of the force F_C about the door hinge at A . Express the result as a Cartesian vector.

Position Vector And Force Vector:

$$\mathbf{r}_{AB} = \{[-0.5 - (-0.5)]\mathbf{i} + [0 - (-1)]\mathbf{j} + (0 - 0)\mathbf{k}\} \text{ m} = \{1\mathbf{j}\} \text{ m}$$

$$\mathbf{F}_C = 250 \left(\frac{[-0.5 - (-1 + 1.5 \cos 30^\circ)]\mathbf{i} + [0 - (-1.5 \sin 30^\circ)]\mathbf{j} + [0 - (-1 + 1.5 \cos 30^\circ)]\mathbf{k}}{\sqrt{[-0.5 - (-1 + 1.5 \cos 30^\circ)]^2 + [0 - (-1.5 \sin 30^\circ)]^2 + [0 - (-1 + 1.5 \cos 30^\circ)]^2}} \right) \text{ N}$$

$$= \{159.33\mathbf{i} + 183.15\mathbf{j} - 59.75\mathbf{k}\} \text{ N}$$

Moment of Force F_C About Point A : Applying Eq. 4-7, we have

$$\mathbf{M}_A = \mathbf{r}_{AB} \times \mathbf{F}_C$$

$$= \begin{vmatrix} \mathbf{i} & \mathbf{j} & \mathbf{k} \\ 0 & 1 & 0 \\ 159.33 & 183.15 & -59.75 \end{vmatrix}$$

$$= \{-59.7\mathbf{i} - 159\mathbf{k}\} \text{ N} \cdot \text{m} \quad \text{Ans}$$

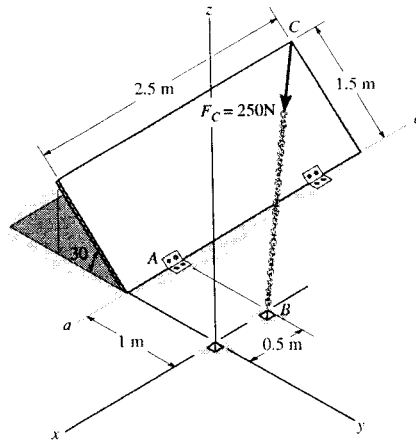

4-165. Determine the magnitude of the moment of the force F_C about the hinged axis aa of the door.

Position Vector And Force Vectors:

$$\mathbf{r}_{AB} = \{[-0.5 - (-0.5)]\mathbf{i} + [0 - (-1)]\mathbf{j} + (0 - 0)\mathbf{k}\} \text{ m} = \{1\mathbf{j}\} \text{ m}$$

$$\mathbf{F}_C = 250 \left(\frac{[-0.5 - (-1 + 1.5 \cos 30^\circ)]\mathbf{i} + [0 - (-1.5 \sin 30^\circ)]\mathbf{j} + [0 - (-1 + 1.5 \cos 30^\circ)]\mathbf{k}}{\sqrt{[-0.5 - (-1 + 1.5 \cos 30^\circ)]^2 + [0 - (-1.5 \sin 30^\circ)]^2 + [0 - (-1 + 1.5 \cos 30^\circ)]^2}} \right) \text{ N}$$

$$= \{159.33\mathbf{i} + 183.15\mathbf{j} - 59.75\mathbf{k}\} \text{ N}$$

Moment of Force F_C About $a-a$ Axis: The unit vector along the $a-a$ axis is \mathbf{i} . Applying Eq. 4-11, we have

$$M_{a-a} = \mathbf{i} \cdot (\mathbf{r}_{AB} \times \mathbf{F}_C)$$

$$= \begin{vmatrix} 1 & 0 & 0 \\ 0 & 1 & 0 \\ 159.33 & 183.15 & -59.75 \end{vmatrix}$$

$$= 1[1(-59.75) - (183.15)(0)] - 0 + 0$$

$$= -59.7 \text{ N} \cdot \text{m}$$

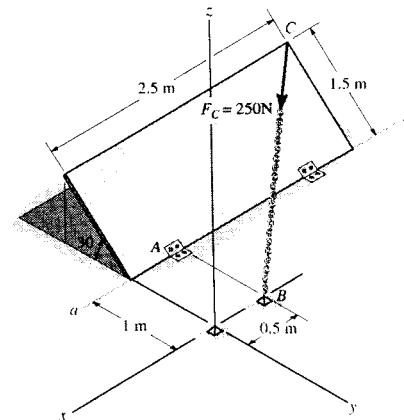

The negative sign indicates that M_{a-a} is directed toward negative x axis.

$$M_{a-a} = 59.7 \text{ N} \cdot \text{m} \quad \text{Ans}$$

4-166. Determine the resultant couple moment of the two couples that act on the assembly. Member OB lies in the x - z plane.

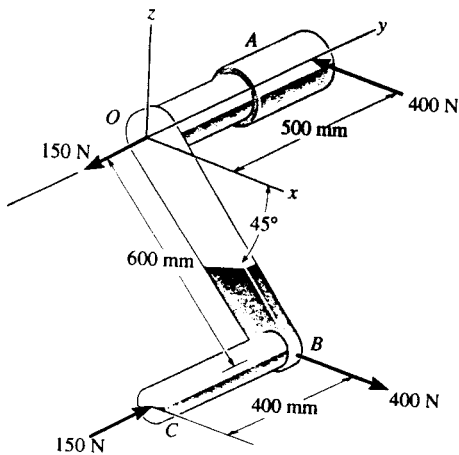

For the 400-N forces :

$$\begin{aligned} M_{C1} &= r_{AB} \times (400i) \\ &= \begin{vmatrix} i & j & k \\ 0.6 \cos 45^\circ & -0.5 & -0.6 \sin 45^\circ \\ 400 & 0 & 0 \end{vmatrix} \\ &= -169.7j + 200k \end{aligned}$$

For the 150-N forces :

$$\begin{aligned} M_{C2} &= r_{OB} \times (150j) \\ &= \begin{vmatrix} i & j & k \\ 0.6 \cos 45^\circ & 0 & -0.6 \sin 45^\circ \\ 0 & 150 & 0 \end{vmatrix} \\ &= 63.6i + 63.6k \end{aligned}$$

$$M_{CR} = M_{C1} + M_{C2}$$

$$M_{CR} = \{63.6i - 170j + 264k\} \text{ N}\cdot\text{m} \quad \text{Ans}$$

4-167. Replace the force F having a magnitude of $F = 50$ lb and acting at point A by an equivalent force and couple moment at point C .

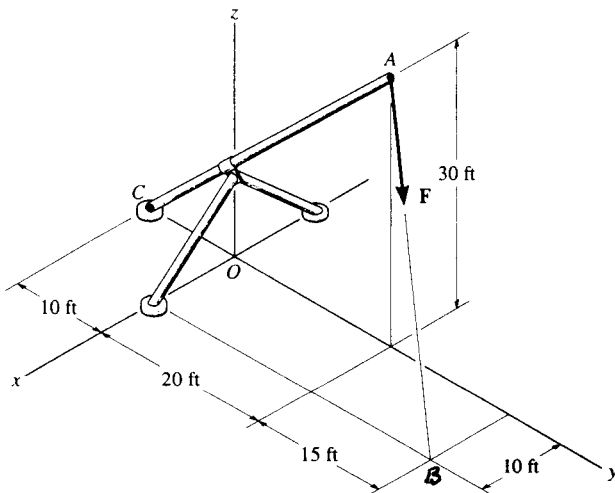

$$F_R = 50 \left[\frac{(10i + 15j - 30k)}{\sqrt{(10)^2 + (15)^2 + (-30)^2}} \right]$$

$$F_R = \{14.3i + 21.4j - 42.9k\} \text{ lb} \quad \text{Ans}$$

$$\begin{aligned} M_{RC} &= r_{CB} \times F = \begin{vmatrix} i & j & k \\ 10 & 45 & 0 \\ 14.29 & 21.43 & -42.86 \end{vmatrix} \\ &= \{-1929i + 428.6j - 428.6k\} \text{ lb}\cdot\text{ft} \end{aligned}$$

$$M_A = \{-1.93i + 0.429j - 0.429k\} \text{ kip}\cdot\text{ft} \quad \text{Ans}$$

***4-168.** The horizontal 30-N force acts on the handle of the wrench. What is the magnitude of the moment of this force about the z axis?

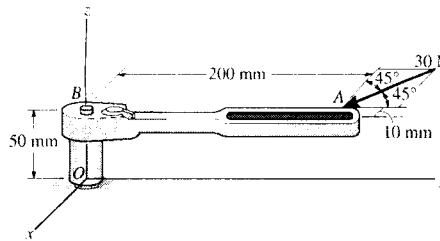

Position Vector And Force Vectors:

$$\mathbf{r}_{BA} = \{-0.01\mathbf{i} + 0.2\mathbf{j}\} \text{ m}$$

$$\begin{aligned} \mathbf{r}_{OA} &= \{(-0.01 - 0)\mathbf{i} + (0.2 - 0)\mathbf{j} + (0.05 - 0)\mathbf{k}\} \text{ m} \\ &= \{-0.01\mathbf{i} + 0.2\mathbf{j} + 0.05\mathbf{k}\} \text{ m} \end{aligned}$$

$$\begin{aligned} \mathbf{F} &= 30(\sin 45^\circ \mathbf{i} - \cos 45^\circ \mathbf{j}) \text{ N} \\ &= \{21.213\mathbf{i} - 21.213\mathbf{j}\} \text{ N} \end{aligned}$$

Moment of Force F About z Axis: The unit vector along the z axis is \mathbf{k} . Applying Eq. 4-11, we have

$$M_z = \mathbf{k} \cdot (\mathbf{r}_{BA} \times \mathbf{F})$$

$$= \begin{vmatrix} 0 & 0 & 1 \\ -0.01 & 0.2 & 0 \\ 21.213 & -21.213 & 0 \end{vmatrix}$$

$$= 0 - 0 + 1[(-0.01)(-21.213) - 21.213(0.2)]$$

$$= -4.03 \text{ N} \cdot \text{m}$$

Ans

Or

$$M_z = \mathbf{k} \cdot (\mathbf{r}_{OA} \times \mathbf{F})$$

$$= \begin{vmatrix} 0 & 0 & 1 \\ -0.01 & 0.2 & 0.05 \\ 21.213 & -21.213 & 0 \end{vmatrix}$$

$$= 0 - 0 + 1[(-0.01)(-21.213) - 21.213(0.2)]$$

$$= -4.03 \text{ N} \cdot \text{m}$$

Ans

The negative sign indicates that M_z is directed along the negative z axis.

4-169. The horizontal 30-N force acts on the handle of the wrench. Determine the moment of this force about point O . Specify the coordinate direction angles α , β , γ of the moment axis.

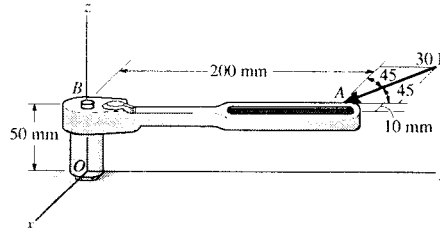

Position Vector And Force Vectors:

$$\begin{aligned} \mathbf{r}_{OA} &= \{(-0.01 - 0)\mathbf{i} + (0.2 - 0)\mathbf{j} + (0.05 - 0)\mathbf{k}\} \text{ m} \\ &= \{-0.01\mathbf{i} + 0.2\mathbf{j} + 0.05\mathbf{k}\} \text{ m} \end{aligned}$$

$$\begin{aligned} \mathbf{F} &= 30(\sin 45^\circ \mathbf{i} - \cos 45^\circ \mathbf{j}) \text{ N} \\ &= \{21.213\mathbf{i} - 21.213\mathbf{j}\} \text{ N} \end{aligned}$$

Moment of Force F About Point O: Applying Eq. 4-7, we have

$$\mathbf{M}_O = \mathbf{r}_{OA} \times \mathbf{F}$$

$$= \begin{vmatrix} \mathbf{i} & \mathbf{j} & \mathbf{k} \\ -0.01 & 0.2 & 0.05 \\ 21.213 & -21.213 & 0 \end{vmatrix}$$

$$= \{1.061\mathbf{i} + 1.061\mathbf{j} - 4.031\mathbf{k}\} \text{ N} \cdot \text{m}$$

$$= \{1.06\mathbf{i} + 1.06\mathbf{j} - 4.03\mathbf{k}\} \text{ N} \cdot \text{m} \quad \text{Ans}$$

The magnitude of \mathbf{M}_O is

$$M_O = \sqrt{1.061^2 + 1.061^2 + (-4.031)^2} = 4.301 \text{ N} \cdot \text{m}$$

The coordinate direction angles for \mathbf{M}_O are

$$\alpha = \cos^{-1} \left(\frac{1.061}{4.301} \right) = 75.7^\circ \quad \text{Ans}$$

$$\beta = \cos^{-1} \left(\frac{1.061}{4.301} \right) = 75.7^\circ \quad \text{Ans}$$

$$\gamma = \cos^{-1} \left(\frac{-4.031}{4.301} \right) = 160^\circ \quad \text{Ans}$$

4-170. The forces and couple moments that are exerted on the toe and heel plates of a snow ski are $\mathbf{F}_t = \{-50\mathbf{i} + 80\mathbf{j} - 158\mathbf{k}\}$ N, $\mathbf{M}_t = \{-6\mathbf{i} + 4\mathbf{j} + 2\mathbf{k}\}$ N·m, and $\mathbf{F}_h = \{-20\mathbf{i} + 60\mathbf{j} - 250\mathbf{k}\}$ N, $\mathbf{M}_h = \{-20\mathbf{i} + 8\mathbf{j} + 3\mathbf{k}\}$ N·m, respectively. Replace this system by an equivalent force and couple moment acting at point P . Express the results in Cartesian vector form.

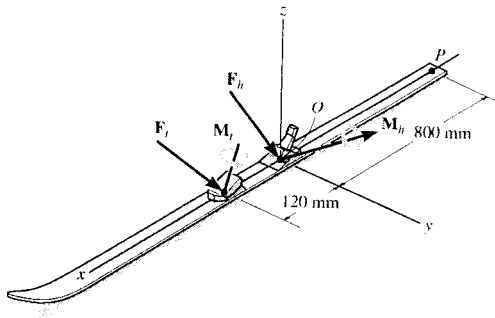

$$\mathbf{F}_R = \mathbf{F}_t + \mathbf{F}_h = \{-70\mathbf{i} + 140\mathbf{j} - 408\mathbf{k}\} \text{ N}$$

Ans

$$\mathbf{M}_{RP} = \begin{vmatrix} \mathbf{i} & \mathbf{j} & \mathbf{k} \\ 0.8 & 0 & 0 \\ -20 & 60 & -250 \end{vmatrix}$$

$$+ \begin{vmatrix} \mathbf{i} & \mathbf{j} & \mathbf{k} \\ 0.92 & 0 & 0 \\ -50 & 80 & -158 \end{vmatrix} + (-6\mathbf{i} + 4\mathbf{j} + 2\mathbf{k}) + (-20\mathbf{i} + 8\mathbf{j} + 3\mathbf{k})$$

$$\mathbf{M}_{RP} = (200\mathbf{j} + 48\mathbf{k}) + (145.36\mathbf{j} + 73.6\mathbf{k})$$

$$+ (-6\mathbf{i} + 4\mathbf{j} + 2\mathbf{k}) + (-20\mathbf{i} + 8\mathbf{j} + 3\mathbf{k})$$

$$\mathbf{M}_{RP} = \{-26\mathbf{i} + 357.36\mathbf{j} + 126.6\mathbf{k}\} \text{ N} \cdot \text{m}$$

$$\mathbf{M}_{RP} = \{-26\mathbf{i} + 357\mathbf{j} + 127\mathbf{k}\} \text{ N} \cdot \text{m}$$

Ans

5-1. Draw the free-body diagram of the 50-kg paper roll which has a center of mass at G and rests on the smooth blade of the paper hauler. Explain the significance of each force acting on the diagram. (See Fig. 5-7b.)

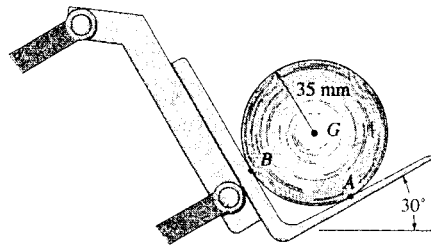

The Significance of Each Force :

W is the effect of gravity (weight) on the paper roll.

N_A and N_B are the smooth blade reactions on the paper roll.

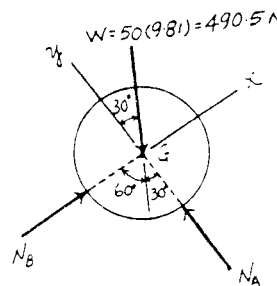

5-2. Draw the free-body diagram of the hand punch, which is pinned at A and bears down on the smooth surface at B .

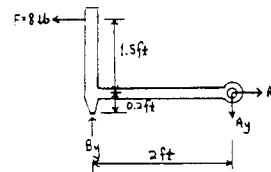
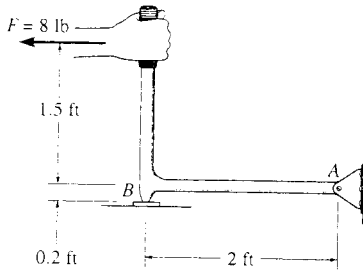

5-3. Draw the free-body diagram of the dumpster D of the truck, which has a weight of 5000 lb and a center of gravity at G . It is supported by a pin at A and a pin-connected hydraulic cylinder BC (short link). Explain the significance of each force on the diagram. (See Fig. 5-7b.)

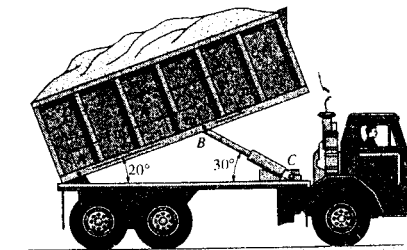

The Significance of Each Force :

W is the effect of gravity (weight) on the dumpster.

A_y and A_x are the pin A reactions on the dumpster.

F_{BC} is the hydraulic cylinder BC reaction on the dumpster.

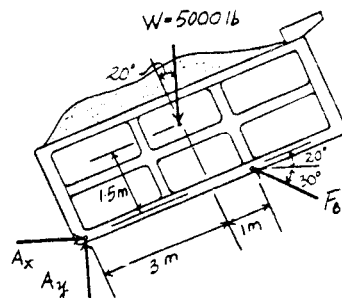

*5-4. Draw the free-body diagram of the jib crane AB , which is pin-connected at A and supported by member (link) BC .

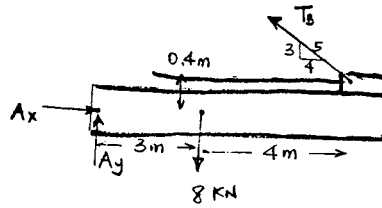
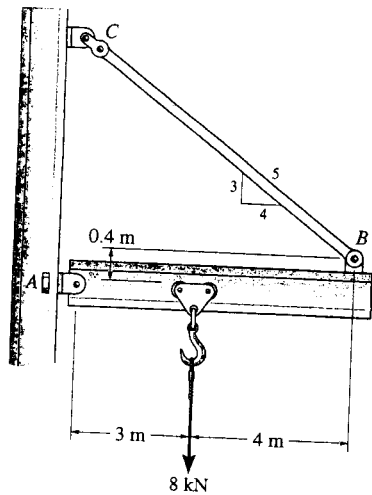

5-5. Draw the free-body diagram of the truss that is supported by the cable AB and pin C . Explain the significance of each force acting on the diagram. (See Fig. 5-7b.)

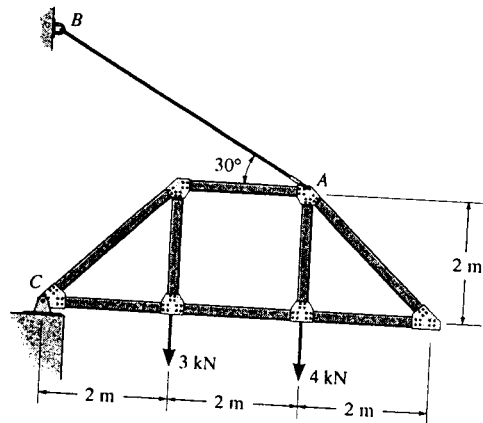

The Significance of Each Force :

C_y and C_x are the pin C reactions on the truss.

T_{AB} is the cable AB tension on the truss.

3 kN and 4 kN force are the effect of external applied forces on the truss.

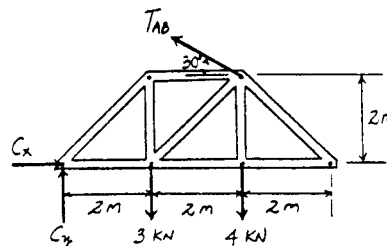

5-6. Draw the free-body diagram of the crane boom AB which has a weight of 650 lb and center of gravity at G . The boom is supported by a pin at A and cable BC . The load of 1250 lb is suspended from a cable attached at B . Explain the significance of each force acting on the diagram. (See Fig. 5-7b.)

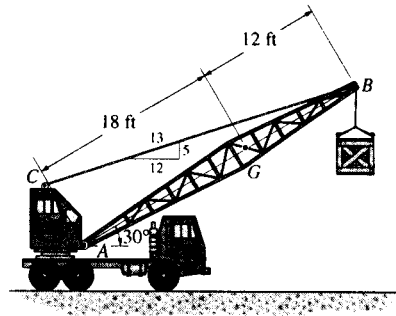

The Significance of Each Force :

- W is the effect of gravity (weight) on the boom.
- A_y and A_x are the pin A reactions on the boom.
- T_{BC} is the cable BC force reactions on the boom.
- 1250 lb force is the suspended load reaction on the boom.

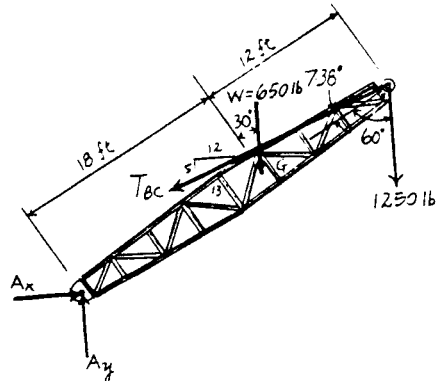

5-7. Draw the free-body diagram of the beam, which is pin-supported at A and rests on the smooth incline at B .

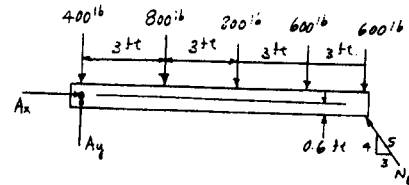
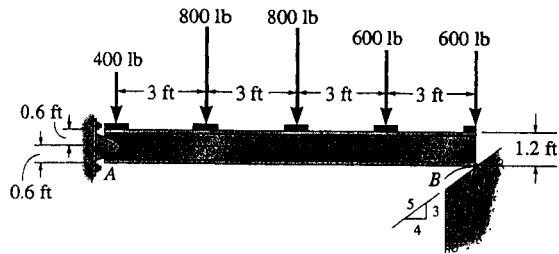

Prob. 5-7

*5-8. Draw the free-body diagram of member ABC which is supported by a smooth collar at A , roller at B , and short link CD . Explain the significance of each force acting on the diagram. (See Fig. 5-7b.)

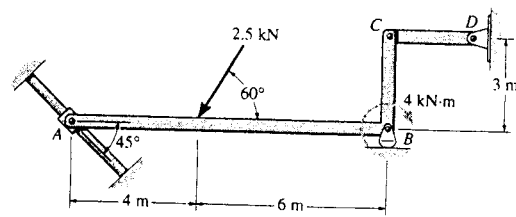

The Significance of Each Force :

N_A is the smooth collar reaction on member ABC .

N_B is the roller support B reaction on member ABC .

F_{CD} is the short link reaction on member ABC .

2.5 kN is the effect of external applied force on member ABC .

4 kN · m is the effect of external applied couple moment on member ABC .

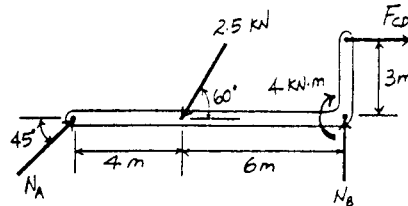

5-9. Draw the free-body diagram of the uniform bar, which has a mass of 100 kg and a center of mass at G . The supports A , B , and C are smooth.

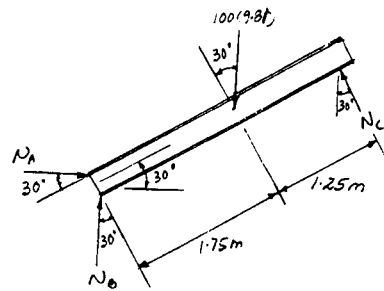
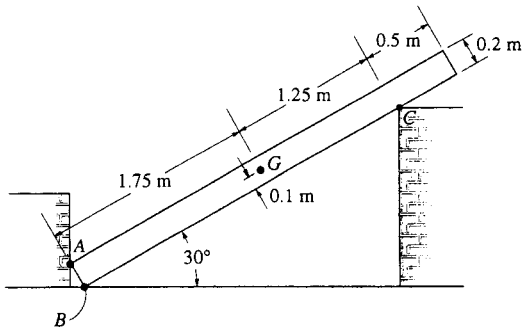

5-10. Draw the free-body diagram of the beam, which is pin-connected at A and rocker-supported at B .

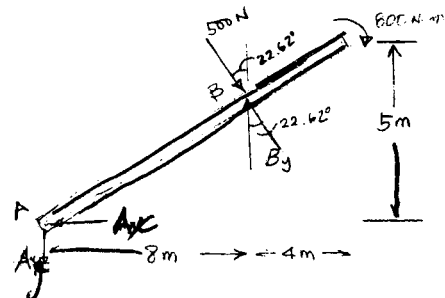
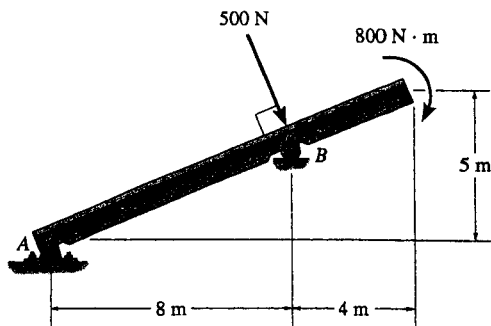

5-11. Determine the reactions at the supports in Prob. 5-1.

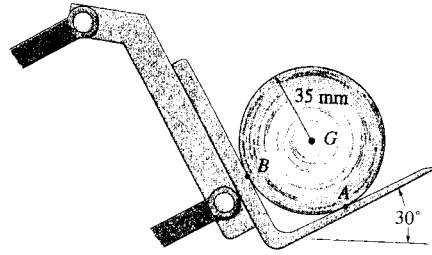

Equations of Equilibrium : By setting up the x and y axes in the manner shown, one can obtain the direct solution for N_A and N_B .

$$\rightarrow + \Sigma F_x = 0; \quad N_B - 490.5 \sin 30^\circ = 0 \quad N_B = 245 \text{ N} \quad \text{Ans}$$

$$\uparrow + \Sigma F_y = 0; \quad N_A - 490.5 \cos 30^\circ = 0 \quad N_A = 425 \text{ N} \quad \text{Ans}$$

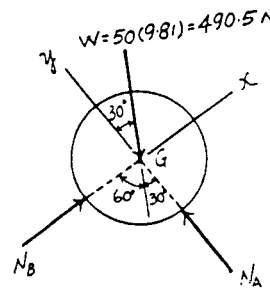

*5-12. Determine the magnitude of the resultant force acting at A of the handpunch in Prob. 5-2.

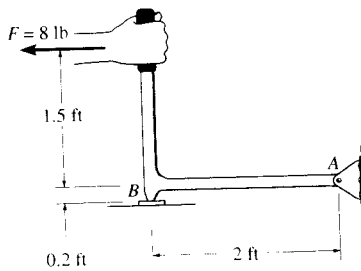

$$\rightarrow + \Sigma F_x = 0; \quad A_x - 8 = 0$$

$$A_x = 8 \text{ lb}$$

$$\curvearrowleft + \Sigma M_B = 0; \quad 8(1.5) - A_y(2) = 0$$

$$A_y = 6 \text{ lb}$$

$$F_A = \sqrt{(8)^2 + (6)^2} = 10 \text{ lb} \quad \text{Ans}$$

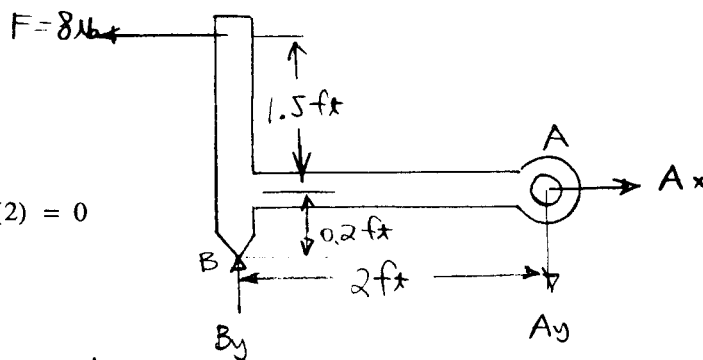

5-13. Determine the reactions at the supports for the truss in Prob. 5-5.

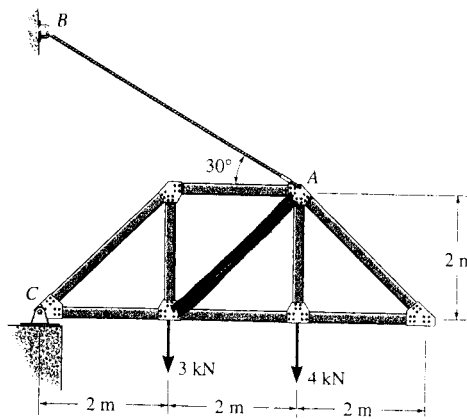

Equations of Equilibrium: The tension in the cable can be obtained directly by summing moments about point C.

$$\begin{aligned} (+ \Sigma M_C = 0; & \quad T_{AB} \cos 30^\circ(2) + T_{AB} \sin 30^\circ(4) - 3(2) - 4(4) = 0 \\ & \quad T_{AB} = 5.89 \text{ kN} \quad \text{Ans} \end{aligned}$$

$$\begin{aligned} \rightarrow \Sigma F_x = 0; & \quad C_x - 5.89 \cos 30^\circ = 0 \\ & \quad C_x = 5.11 \text{ kN} \quad \text{Ans} \end{aligned}$$

$$\begin{aligned} + \uparrow \Sigma F_y = 0; & \quad C_y + 5.89 \sin 30^\circ - 3 - 4 = 0 \\ & \quad C_y = 4.05 \text{ kN} \quad \text{Ans} \end{aligned}$$

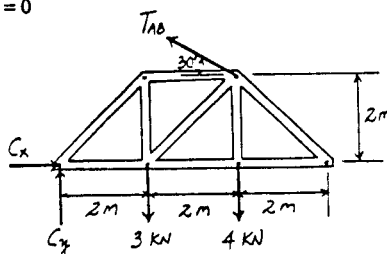

5-14. Determine the reactions on the boom in Prob. 5-6.

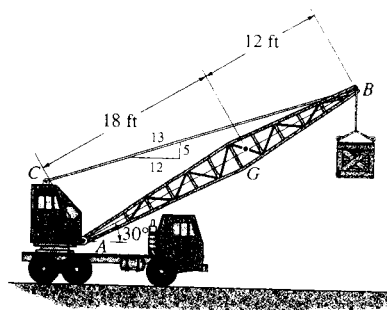

Equations of Equilibrium: The force in cable BC can be obtained directly by summing moments about point A.

$$\begin{aligned} (+ \Sigma M_A = 0; & \quad T_{BC} \sin 7.380^\circ(30) - 650 \cos 30^\circ(18) \\ & \quad - 1250 \sin 60^\circ(30) = 0 \end{aligned}$$

$$T_{BC} = 11056.9 \text{ lb} = 11.1 \text{ kip} \quad \text{Ans}$$

$$\rightarrow \Sigma F_x = 0; \quad A_x - 11056.9 \left(\frac{12}{13} \right) = 0$$

$$A_x = 10206.4 \text{ lb} = 10.2 \text{ kip} \quad \text{Ans}$$

$$+ \uparrow \Sigma F_y = 0; \quad A_y - 650 - 1250 - 11056.9 \left(\frac{5}{13} \right) = 0$$

$$A_y = 6152.7 \text{ lb} = 6.15 \text{ kip} \quad \text{Ans}$$

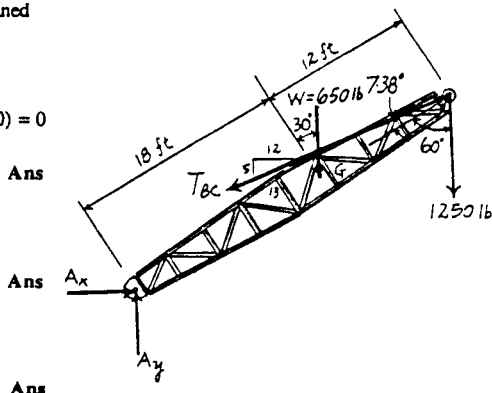

5-15. Determine the support reactions on the beam in Prob. 5-7.

$$(+ \Sigma M_A = 0; \quad \frac{4}{3}N_B(12) - \frac{3}{5}N_B(0.6) - 800(3) - 800(6) - 600(9) - 600(12) = 0$$

$$N_B = 2142.86 \text{ lb} = 2.14 \text{ kip}$$

Ans

$$(\rightarrow \Sigma F_x = 0; \quad A_x - \frac{3}{5}(2142.86) = 0$$

$$A_x = 1286 \text{ lb} = 1.29 \text{ kip}$$

Ans

$$(+ \uparrow \Sigma F_y = 0; \quad A_y + \frac{4}{5}(2142.86) - 400 - 800 - 800 - 600 - 600 = 0$$

$$A_y = 1486 \text{ lb} = 1.49 \text{ kip}$$

Ans

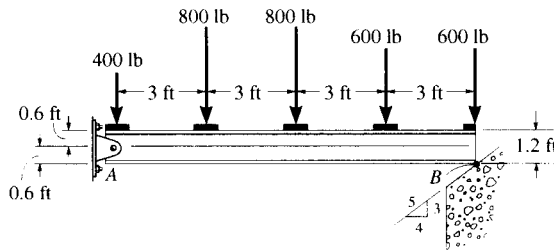

*5-16. Determine the reactions on the member A, B, C in Prob. 5-8.

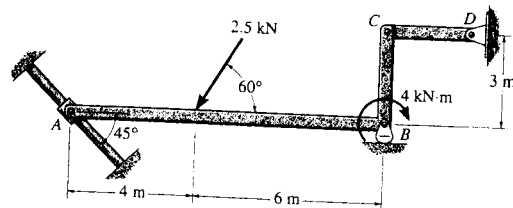

Equations of Equilibrium: The normal reaction N_A can be obtained directly by summing moments about point C.

$$(+ \Sigma M_C = 0; \quad 2.5 \sin 60^\circ(6) - 2.5 \cos 60^\circ(3) - 4 + N_A \cos 45^\circ(3) - N_A \sin 45^\circ(10) = 0$$

$$N_A = 1.059 \text{ kN} = 1.06 \text{ kN}$$

Ans

$$(\rightarrow \Sigma F_x = 0; \quad 1.059 \cos 45^\circ - 2.5 \cos 60^\circ + F_{CD} = 0$$

$$F_{CD} = 0.501 \text{ kN}$$

Ans

$$(+ \uparrow \Sigma F_y = 0; \quad N_B + 1.059 \sin 45^\circ - 2.5 \sin 60^\circ = 0$$

$$N_B = 1.42 \text{ kN}$$

Ans

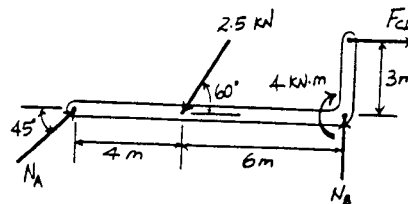

5-17. Determine the reactions at the points of contact at A, B, and C of the bar in Prob. 5-9.

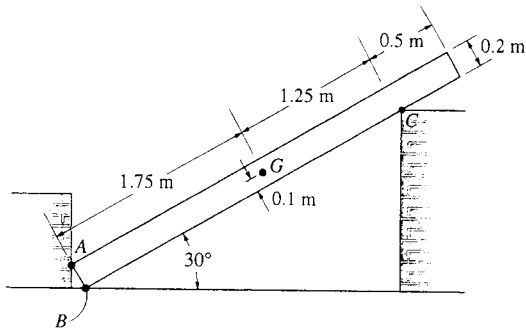

$$\begin{aligned} \sum M_A = 0; & \quad -100(9.81)(\cos 30^\circ)(1.75) - 100(9.81)(\sin 30^\circ)(0.1) \\ & \quad + N_B(\sin 30^\circ)(0.2) + N_C(3) = 0 \\ & \quad -1535.7991 + 0.1N_B + 3N_C = 0 \end{aligned}$$

$$\sum F_y = 0; \quad N_B - 100(9.81) + N_C \cos 30^\circ = 0$$

$$N_B = 981 - N_C(\cos 30^\circ)$$

$$\sum F_x = 0; \quad N_A - N_C(\sin 30^\circ) = 0$$

Solving:

$$N_C = 493 \text{ N} \quad \text{Ans}$$

$$N_B = 554 \text{ N} \quad \text{Ans}$$

$$N_A = 247 \text{ N} \quad \text{Ans}$$

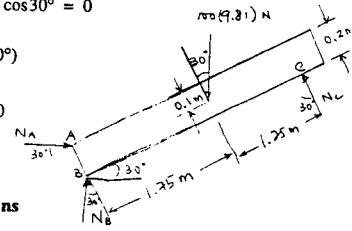

5-18. Determine the reactions at the pin A and at the roller at B of the beam in Prob. 5-10.

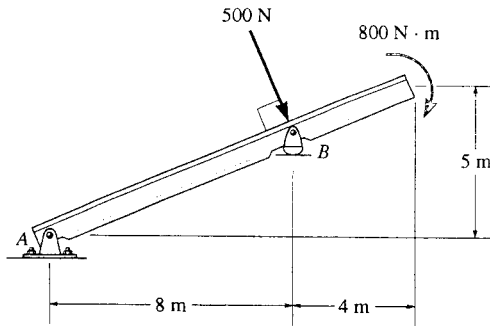

$$\sum M_A = 0; \quad -500\left(\frac{8}{\cos 22.6198^\circ}\right) - 800 + B_y(8) = 0$$

$$B_y = 641.6667 = 642 \text{ N} \quad \text{Ans}$$

$$\sum F_x = 0; \quad -A_x + 500(\sin 22.6198^\circ) = 0$$

$$A_x = 192 \text{ N} \quad \text{Ans}$$

$$\sum F_y = 0; \quad -A_y - 500(\cos 22.6198^\circ) + 641.6667 = 0$$

$$A_y = 180 \text{ N} \quad \text{Ans}$$

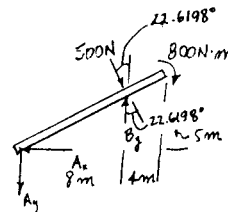

5-19. Determine the magnitude of the reactions on the beam at A and B. Neglect the thickness of the beam.

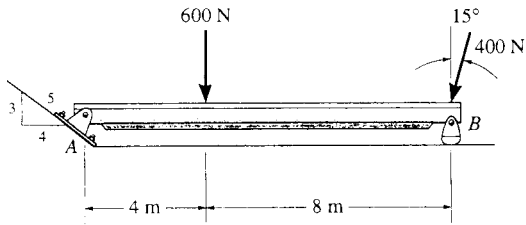

$$\begin{aligned} +\Sigma M_A = 0; & \quad B_y(12) - (400 \cos 15^\circ)(12) - 600(4) = 0 \\ & \quad B_y = 586.37 = 586 \text{ N} \quad \text{Ans} \\ +\Sigma F_x = 0; & \quad A_x - 400 \sin 15^\circ = 0 \\ & \quad A_x = 103.528 \text{ N} \\ +\Sigma F_y = 0; & \quad A_y - 600 - 400 \cos 15^\circ + 586.37 = 0 \\ & \quad A_y = 400 \text{ N} \\ & \quad F_A = \sqrt{(103.528)^2 + (400)^2} = 413 \text{ N} \quad \text{Ans} \end{aligned}$$

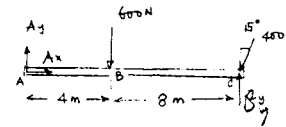

*5-20. Determine the reactions at the supports A and B of the frame.

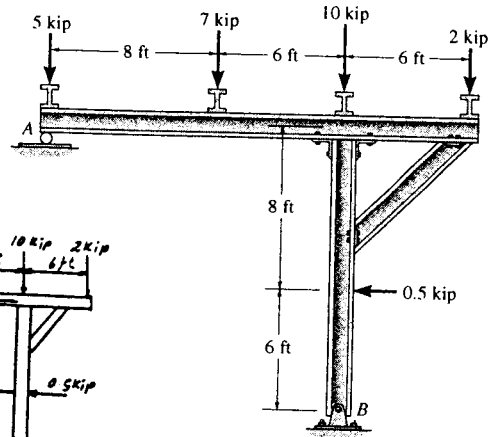

$$\begin{aligned} +\Sigma M_B = 0; & \quad 5(14) + 7(6) + 0.5(6) - 2(6) - A_y(14) = 0 \\ & \quad A_y = 7.357 \text{ kip} = 7.36 \text{ kip} \\ +\Sigma F_x = 0; & \quad B_x - 0.5 = 0 \quad B_x = 0.5 \text{ kip} \\ +\Sigma F_y = 0; & \quad B_y + 7.357 - 5 - 7 - 10 - 2 = 0 \\ & \quad B_y = 16.6 \text{ kip} \quad \text{Ans} \end{aligned}$$

Ans
Ans
Ans

5-21. When holding the 5-lb stone in equilibrium, the humerus H, assumed to be smooth, exerts normal forces F_C and F_A on the radius C and ulna A as shown. Determine these forces and the force F_B that the biceps B exerts on the radius for equilibrium. The stone has a center of mass at G. Neglect the weight of the arm.

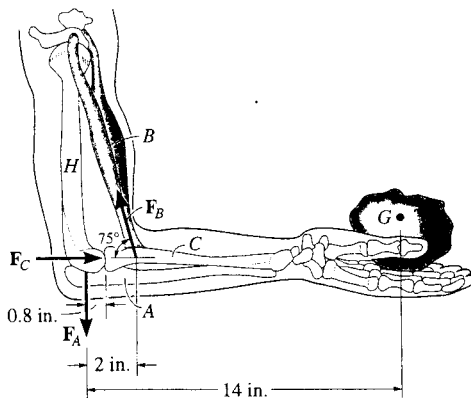

$$\begin{aligned} +\Sigma M_B = 0; & \quad -5(12) + F_A(2) = 0 \\ & \quad F_A = 30 \text{ lb} \quad \text{Ans} \\ +\Sigma F_y = 0; & \quad F_B \sin 75^\circ - 5 - 30 = 0 \\ & \quad F_B = 36.2 \text{ lb} \quad \text{Ans} \\ +\Sigma F_x = 0; & \quad F_C - 36.2 \cos 75^\circ = 0 \\ & \quad F_C = 9.38 \text{ lb} \quad \text{Ans} \end{aligned}$$

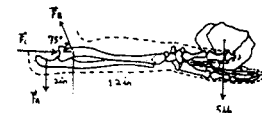

5-22. The man is pulling a load of 8 lb with one arm held as shown. Determine the force F_H this exerts on the humerus bone H , and the tension developed in the biceps muscle B . Neglect the weight of the man's arm.

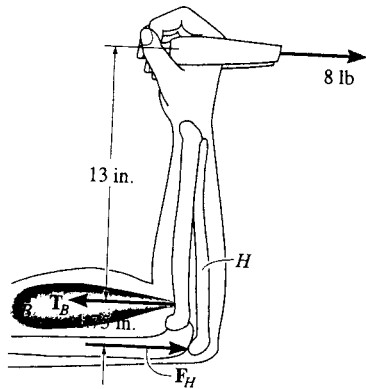

$$\sum M_B = 0;$$

$$-8(13) + F_H(1.75) = 0$$

$$F_H = 59.43 = 59.4 \text{ lb}$$

Ans

$$\sum F_x = 0;$$

$$8 - T_B + 59.43 = 0$$

$$T_B = 67.4 \text{ lb}$$

Ans

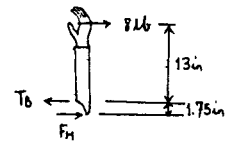

5-23. The ramp of a ship has a weight of 200 lb and a center of gravity at G . Determine the cable force in CD needed to just start lifting the ramp, (i.e., so the reaction at B becomes zero). Also, determine the horizontal and vertical components of force at the hinge (pin) at A .

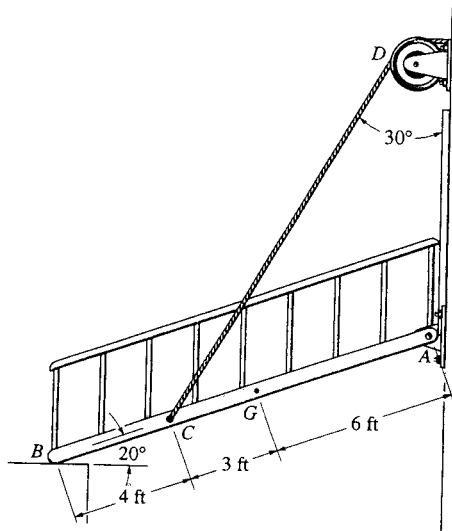

$$\sum M_A = 0;$$

$$-F_{CD} \cos 30^\circ (9 \cos 20^\circ) + F_{CD} \sin 30^\circ (9 \sin 20^\circ) + 200(6 \cos 20^\circ) = 0$$

$$F_{CD} = 194.9 = 195 \text{ lb}$$

Ans

$$\sum F_x = 0;$$

$$194.9 \sin 30^\circ - A_x = 0$$

$$A_x = 97.4 \text{ lb}$$

Ans

$$\sum F_y = 0;$$

$$A_y - 200 + 194.9 \cos 30^\circ = 0$$

$$A_y = 31.2 \text{ lb}$$

Ans

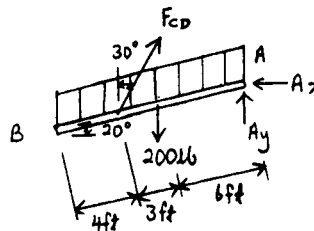

***5-24.** Determine the magnitude of force at the pin A and in the cable BC needed to support the 500-lb load. Neglect the weight of the boom AB .

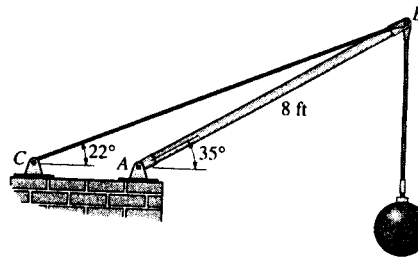

Equations of Equilibrium: The force in cable BC can be obtained directly by summing moments about point A .

$$\begin{aligned} \left(+ \Sigma M_A = 0; \quad F_{BC} \sin 13^\circ (8) - 500 \cos 35^\circ (8) = 0 \right. \\ \left. F_{BC} = 1820.7 \text{ lb} = 1.82 \text{ kip} \right. \quad \text{Ans} \end{aligned}$$

$$\begin{aligned} \left(+ \Sigma F_x = 0; \quad A_x - 1820.7 \cos 13^\circ - 500 \sin 35^\circ = 0 \right. \\ \left. A_x = 2060.9 \text{ lb} \right. \end{aligned}$$

$$\begin{aligned} \left(+ \Sigma F_y = 0; \quad A_y + 1820.7 \sin 13^\circ - 500 \cos 35^\circ = 0 \right. \\ \left. A_y = 0 \right. \end{aligned}$$

Thus, $F_A = A_x = 2060.9 \text{ lb} = 2.06 \text{ kip}$ **Ans**

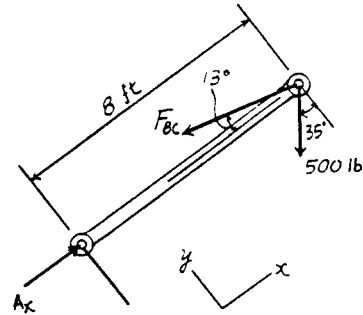

5-25. Compare the force exerted on the toe and heel of a 120-lb woman when she is wearing regular shoes and stiletto heels. Assume all her weight is placed on one foot and the reactions occur at points *A* and *B* as shown.

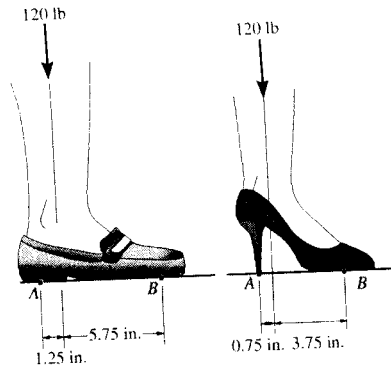

Equations of Equilibrium: Regular shoe, we have

$$\begin{aligned} \curvearrowleft +\Sigma M_B = 0; \quad 120(5.75) - (N_A)_r(7) &= 0 \\ (N_A)_r &= 98.6 \text{ lb} \quad \text{Ans} \end{aligned}$$

Stiletto heel shoe,

$$\begin{aligned} \curvearrowleft +\Sigma M_B = 0; \quad 120(3.75) - (N_A)_s(4.5) &= 0 \\ (N_A)_s &= 100 \text{ lb} \quad \text{Ans} \end{aligned}$$

The heel of the stiletto shoe is subjected to a greater force than that of the heel of the regular shoe. Actually the force per area (stress) under the stiletto heel will be much greater than that of the regular shoe. It is this stress that can cause damage to soft flooring.

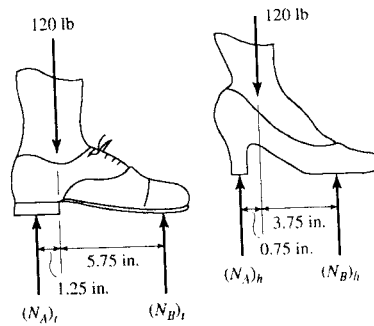

5-26. Determine the reactions at the pins *A* and *B*. The spring has an unstretched length of 80 mm.

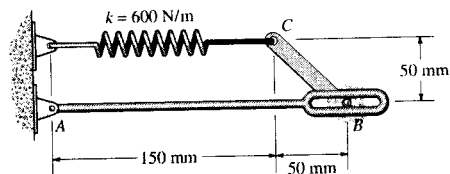

Spring Force: The spring stretches $x = 0.15 - 0.08 = 0.07$ m. Applying the spring formula, we have

$$F_{sp} = kx = 600(0.07) = 42.0 \text{ N}$$

Equations of Equilibrium: The normal reaction N_B can be obtained directly by summing moments about point *A*.

$$\begin{aligned} \curvearrowleft +\Sigma M_A = 0; \quad 42.0(0.05) - N_B(0.2) &= 0 \\ N_B &= 10.5 \text{ N} \quad \text{Ans} \end{aligned}$$

$$\rightarrow +\Sigma F_x = 0; \quad A_x - 42.0 = 0 \quad A_x = 42.0 \text{ N} \quad \text{Ans}$$

$$+\uparrow \Sigma F_y = 0; \quad A_y - 10.5 = 0 \quad A_y = 10.5 \text{ N} \quad \text{Ans}$$

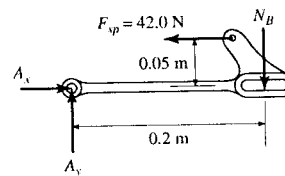

5-27. The platform assembly has a weight of 250 lb and center of gravity at G_1 . If it is intended to support a maximum load of 400 lb placed at point G_2 , determine the smallest counterweight W that should be placed at B in order to prevent the platform from tipping over.

When tipping occurs, $R_c = 0$

$$\sum M_D = 0; \quad -400(2) + 250(1) + W_B(7) = 0$$

$$W_B = 78.6 \text{ lb} \quad \text{Ans}$$

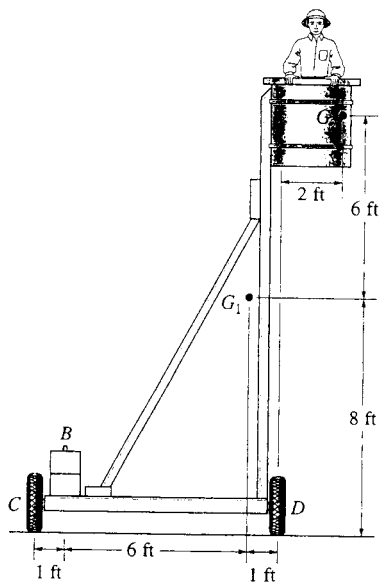
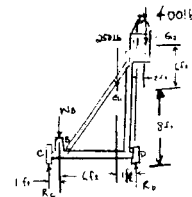

*5-28. Determine the tension in the cable and the horizontal and vertical components of reaction of the pin A . The pulley at D is frictionless and the cylinder weighs 80 lb.

Equations of Equilibrium: The tension force developed in the cable is the same throughout the whole cable. The force in the cable can be obtained directly by summing moments about point A .

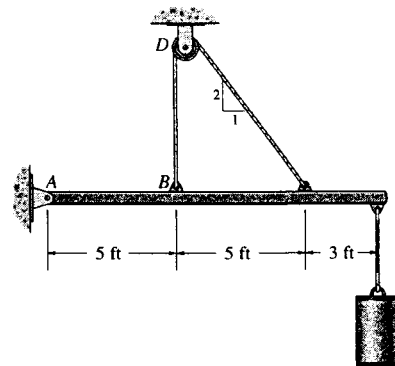

$$\begin{aligned} \sum M_A = 0; \quad T(5) + T\left(\frac{2}{\sqrt{5}}\right)(10) - 80(13) &= 0 \\ T &= 74.583 \text{ lb} = 74.6 \text{ lb} \quad \text{Ans} \end{aligned}$$

$$\begin{aligned} \sum F_x = 0; \quad A_x - 74.583\left(\frac{1}{\sqrt{5}}\right) &= 0 \\ A_x &= 33.4 \text{ lb} \quad \text{Ans} \end{aligned}$$

$$\begin{aligned} \sum F_y = 0; \quad 74.583 + 74.583\left(\frac{2}{\sqrt{5}}\right) - 80 - B_y &= 0 \\ B_y &= 61.3 \text{ lb} \quad \text{Ans} \end{aligned}$$

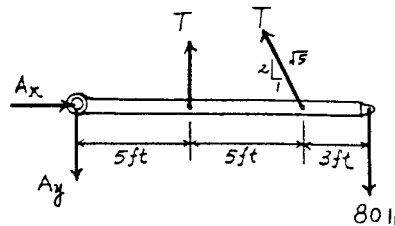

5-29. The device is used to hold an elevator door open. If the spring has a stiffness of $k = 40 \text{ N/m}$ and it is compressed 0.2 m , determine the horizontal and vertical components of reaction at the pin A and the resultant force at the wheel bearing B .

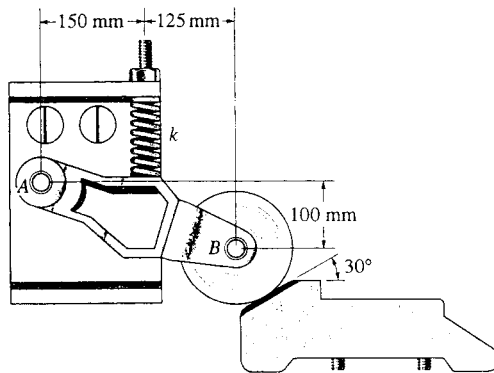

$$F_s = ks = (40)(0.2) = 8 \text{ N}$$

$$\zeta + \Sigma M_A = 0; \quad -(8)(150) + F_B(\cos 30^\circ)(275) - F_B(\sin 30^\circ)(100) = 0$$

$$F_B = 6.37765 \text{ N} = 6.38 \text{ N} \quad \text{Ans}$$

$$\rightarrow \Sigma F_x = 0; \quad A_x - 6.37765 \sin 30^\circ = 0$$

$$A_x = 3.19 \text{ N} \quad \text{Ans}$$

$$+ \uparrow \Sigma F_y = 0; \quad A_y - 8 + 6.37765 \cos 30^\circ = 0$$

$$A_y = 2.48 \text{ N} \quad \text{Ans}$$

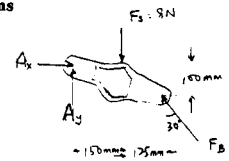

5-30. The cutter is subjected to a horizontal force of 580 lb and a normal force of 350 lb . Determine the horizontal and vertical components of force acting on the pin A and the force along the hydraulic cylinder BC (a two-force member).

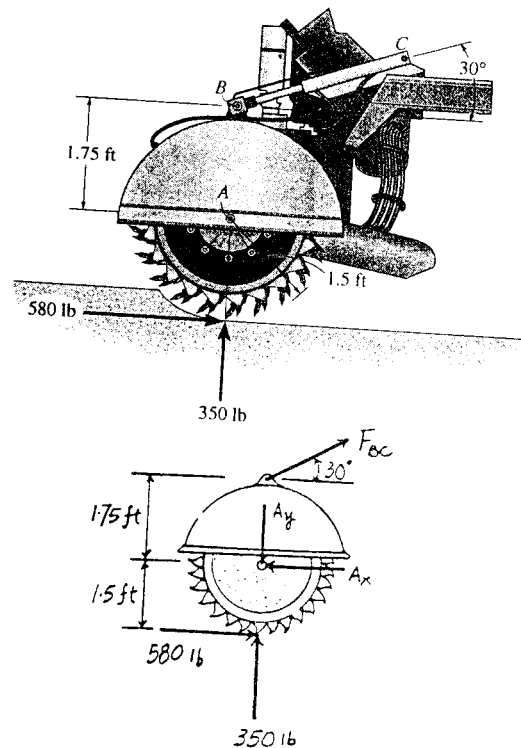

Equations of Equilibrium: The force in hydraulic cylinder BC can be obtained directly by summing moments about point A .

$$\zeta + \Sigma M_A = 0; \quad 580(1.5) - F_{BC} \cos 30^\circ(1.75) = 0$$

$$F_{BC} = 574.05 \text{ lb} = 574 \text{ lb} \quad \text{Ans}$$

$$\rightarrow \Sigma F_x = 0; \quad 574.05 \cos 30^\circ + 580 - A_x = 0$$

$$A_x = 1077 \text{ lb} = 1.08 \text{ kip} \quad \text{Ans}$$

$$+ \uparrow \Sigma F_y = 0; \quad 574.05 \sin 30^\circ + 350 - A_y = 0$$

$$A_y = 637 \text{ lb} \quad \text{Ans}$$

5-31. The cantilevered jib crane is used to support the load of 780 lb. If the trolley T can be placed anywhere between $1.5 \text{ ft} \leq x \leq 7.5 \text{ ft}$, determine the maximum magnitude of reaction at the supports A and B . Note that the supports are collars that allow the crane to rotate freely about the vertical axis. The collar at B supports a force in the vertical direction, whereas the one at A does not.

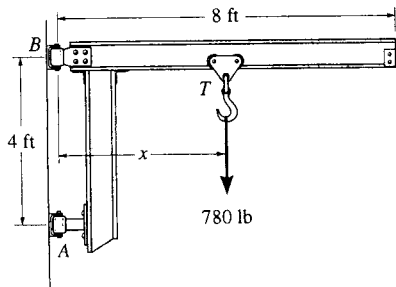

Require $x = 7.5 \text{ ft}$

$$+\Sigma M_A = 0; \quad -780(7.5) + B_y(4) = 0$$

$$B_y = 1462.5 \text{ lb}$$

$$+\Sigma F_x = 0; \quad A_x - 1462.5 = 0$$

$$A_x = 1462.5 = 1462 \text{ lb}$$

$$+\Sigma F_y = 0; \quad B_y - 780 = 0$$

$$B_y = 780 \text{ lb}$$

$$F_B = \sqrt{(1462.5)^2 + (780)^2}$$

$$= 1657.5 \text{ lb} = 1.66 \text{ kip}$$

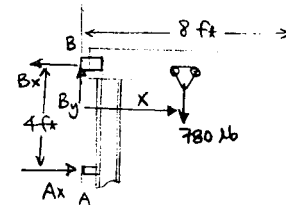

Ans

Ans

*5-32. The sports car has a mass of 1.5 Mg and mass center at G . If the front two springs each have a stiffness of $k_A = 58 \text{ kN/m}$ and the rear two springs each have a stiffness of $k_B = 65 \text{ kN/m}$, determine their compression when the car is parked on the 30° incline. Also, what friction force F_B must be applied to each of the rear wheels to hold the car in equilibrium? *Hint:* First determine the normal force at A and B , then determine the compression in the springs.

Equations of Equilibrium: The normal reaction N_A can be obtained directly by summing moments about point B .

$$(+\Sigma M_B = 0; \quad 14715 \cos 30^\circ (1.2) - 14715 \sin 30^\circ (0.4) - 2N_A (2) = 0$$

$$N_A = 3087.32 \text{ N}$$

$$+\Sigma F_x = 0; \quad 2F_B - 14715 \sin 30^\circ = 0$$

$$F_B = 3678.75 \text{ N} = 3.68 \text{ kN} \quad \text{Ans}$$

$$+\Sigma F_y = 0; \quad 2N_B + 2(3087.32) - 14715 \cos 30^\circ = 0$$

$$N_B = 3284.46 \text{ N}$$

Spring Force Formula: The compression of the spring can be determined using the spring formula $x = \frac{F_{sp}}{k}$.

$$x_A = \frac{3087.32}{58(10^3)} = 0.05323 \text{ m} = 53.2 \text{ mm} \quad \text{Ans}$$

$$x_B = \frac{3284.46}{65(10^3)} = 0.05053 \text{ m} = 50.5 \text{ mm} \quad \text{Ans}$$

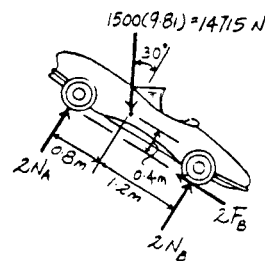
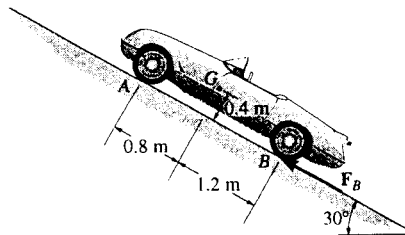

5-33. The power pole supports the three lines, each line exerting a vertical force on the pole due to its weight as shown. Determine the reactions at the fixed support D . If it is possible for wind or ice to snap the lines, determine which line(s) when removed create(s) a condition for the greatest moment reaction at D .

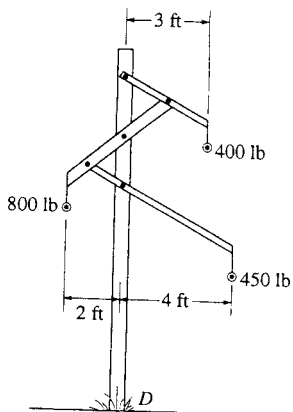

$$\begin{aligned} \rightarrow \Sigma F_x = 0; & \quad D_x = 0 & \text{Ans} \\ + \uparrow \Sigma F_y = 0; & \quad D_y - 1650 = 0 \\ & \quad D_y = 1.65 \text{ kip} & \text{Ans} \\ \curvearrowleft + \Sigma M_D = 0; & \quad -450(4) - 400(3) + 800(2) + M_D = 0 \\ & \quad M_D = 1.40 \text{ kip}\cdot\text{ft} & \text{Ans} \end{aligned}$$

Require 800 lb line to snap.

$$(M_D)_{\max} = 3.00 \text{ kip}\cdot\text{ft} \quad \text{Ans}$$

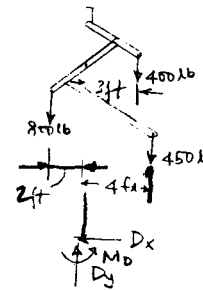

5-34. The jib crane is pin-connected at A and supported by a smooth collar at B . Determine the roller placement x of the 5000-lb load so that it gives the maximum and minimum reactions at the supports. Calculate these reactions in each case. Neglect the weight of the crane. Require $4 \text{ ft} \leq x \leq 10 \text{ ft}$.

Equations of Equilibrium :

$$\curvearrowleft + \Sigma M_A = 0; \quad N_B(12) - 5x = 0 \quad N_B = 0.4167x \quad [1]$$

$$+ \uparrow \Sigma F_y = 0; \quad A_y - 5 = 0 \quad A_y = 5.00 \text{ kip} \quad [2]$$

$$\rightarrow \Sigma F_x = 0; \quad A_x - 0.4167x = 0 \quad A_x = 0.4167x \quad [3]$$

By observation, the maximum support reactions occur when

$$x = 10 \text{ ft} \quad \text{Ans}$$

With $x = 10 \text{ ft}$, from Eqs. [1], [2] and [3], the maximum support reactions are

$$A_x = N_B = 4.17 \text{ kip} \quad A_y = 5.00 \text{ kip} \quad \text{Ans}$$

By observation, the minimum support reactions occur when

$$x = 4 \text{ ft} \quad \text{Ans}$$

With $x = 4 \text{ ft}$, from Eqs. [1], [2] and [3], the minimum support reactions are

$$A_x = N_B = 1.67 \text{ kip} \quad A_y = 5.00 \text{ kip} \quad \text{Ans}$$

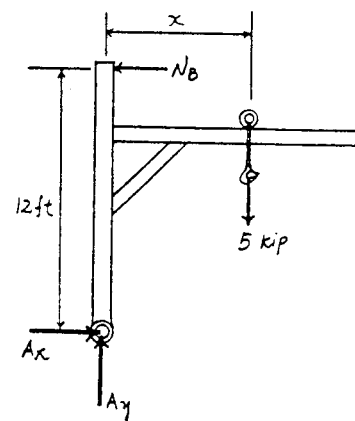
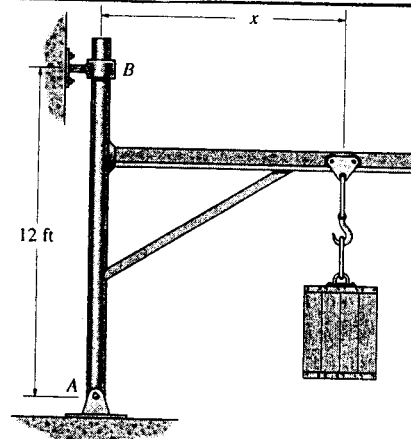

5-35. If the wheelbarrow and its contents have a mass of 60 kg and center of mass at G , determine the magnitude of the resultant force which the man must exert on *each* of the two handles in order to hold the wheelbarrow in equilibrium.

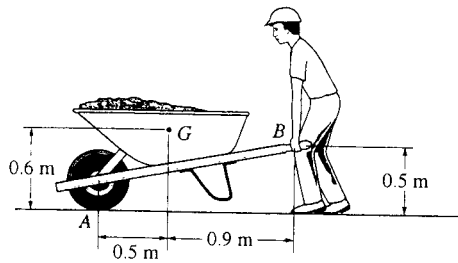

$$+\circlearrowleft \Sigma M_B = 0; \quad -A_y(1.4) + 60(9.81)(0.9) = 0$$

$$A_y = 378.39 \text{ N}$$

$$+\uparrow \Sigma F_y = 0; \quad 378.39 - 60(9.81) + 2B_y = 0$$

$$B_y = 105.11 \text{ N}$$

$$\rightarrow \Sigma F_x = 0; \quad B_x = 0$$

$$F_B = 105 \text{ N} \quad \text{Ans}$$

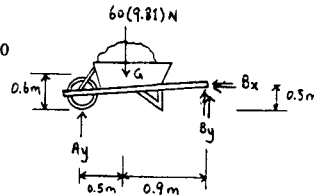

*5-36. The pad footing is used to support the load of 12 000 lb. Determine the intensities w_1 and w_2 of the distributed loading acting on the base of the footing for the equilibrium.

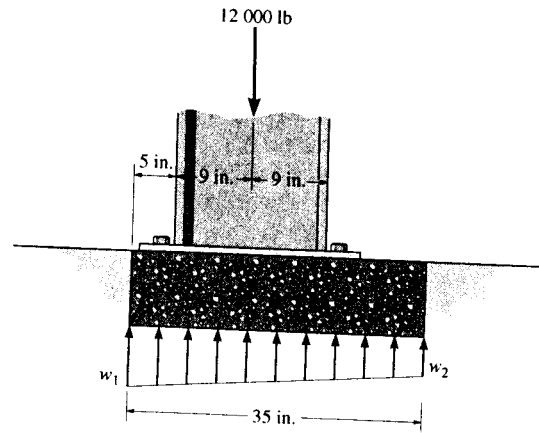

Equations of Equilibrium: The load intensity w_2 can be determined directly by summing moments about point A.

$$\begin{aligned} \left(+ \Sigma M_A = 0; \quad w_2 \left(\frac{35}{12} \right) (17.5 - 11.67) - 12(14 - 11.67) = 0 \right. \\ \left. w_2 = 1.646 \text{ kip/ft} = 1.65 \text{ kip/ft} \quad \text{Ans} \right. \end{aligned}$$

$$\begin{aligned} + \uparrow \Sigma F_y = 0; \quad \frac{1}{2} (w_1 - 1.646) \left(\frac{35}{12} \right) + 2.743 \left(\frac{35}{12} \right) - 12 = 0 \\ w_1 = 6.58 \text{ kip/ft} \quad \text{Ans} \end{aligned}$$

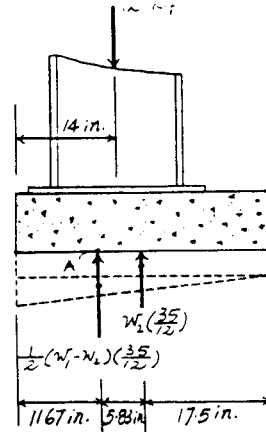

5-37. The bulk head AD is subjected to both water and soil-backfill pressures. Assuming AD is "pinned" to the ground at A , determine the horizontal and vertical reactions there and also the required tension in the ground anchor BC necessary for equilibrium. The bulk head has a mass of 800 kg.

Equations of Equilibrium: The force in ground anchor BC can be obtained directly by summing moments about point A .

$$\begin{aligned} \left(+ \Sigma M_A = 0; \quad 1007.5(2.167) - 236(1.333) - F(6) = 0 \right. \\ \left. F = 311.375 \text{ kN} = 311 \text{ kN} \quad \text{Ans} \right. \end{aligned}$$

$$\begin{aligned} \rightarrow \Sigma F_x = 0; \quad A_x + 311.375 + 236 - 1007.5 = 0 \\ A_x = 460 \text{ kN} \quad \text{Ans} \end{aligned}$$

$$+ \uparrow \Sigma F_y = 0; \quad A_y - 7.848 = 0 \quad A_y = 7.85 \text{ kN} \quad \text{Ans}$$

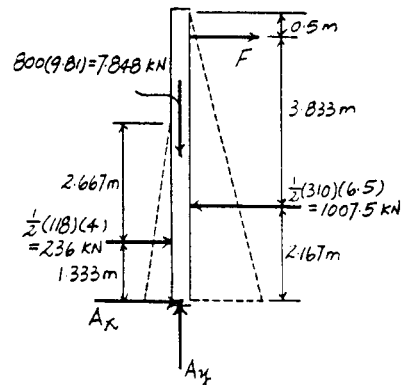
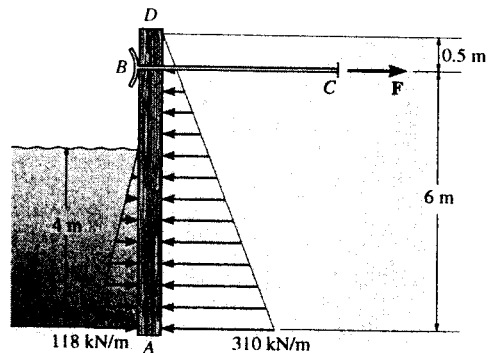

5-38. The telephone pole of negligible thickness is subjected to the force of 80 lb directed as shown. It is supported by the cable BCD and can be assumed pinned at its base A . In order to provide clearance for a sidewalk right of way, where D is located, a strut CE is attached at C , as shown by the dashed lines (cable segment CD is removed). If the tension in CD' is to be twice the tension in BCD , determine the height h for placement of the strut CE .

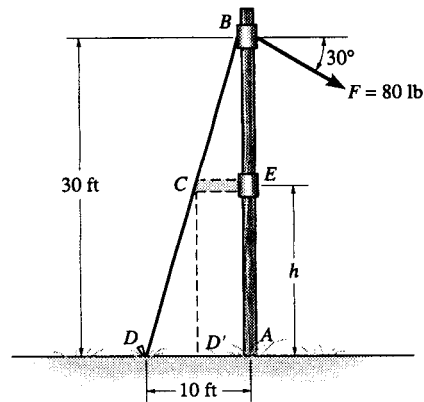

$$\curvearrowleft +\Sigma M_A = 0; \quad -80(30) \cos 30^\circ + \frac{1}{\sqrt{10}} T_{BCD}(30) = 0$$

$$T_{BCD} = 219.089 \text{ lb}$$

$$\text{Require } T_{CD'} = 2(219.089) = 438.178 \text{ lb}$$

$$+\Sigma M_A = 0; \quad 438.178(d) - 80 \cos 30^\circ (30) = 0$$

$$d = 4.7434 \text{ ft}$$

$$\frac{30 - h}{4.7434} = \frac{30}{10}$$

$$300 - 10h = 142.3025$$

$$h = 15.8 \text{ ft} \quad \text{Ans}$$

5-39. The worker uses the hand truck to move material down the ramp. If the truck and its contents are held in the position shown and have a weight of 100 lb with center of gravity at G , determine the resultant normal force of both wheels on the ground A and the magnitude of the force required at the grip B .

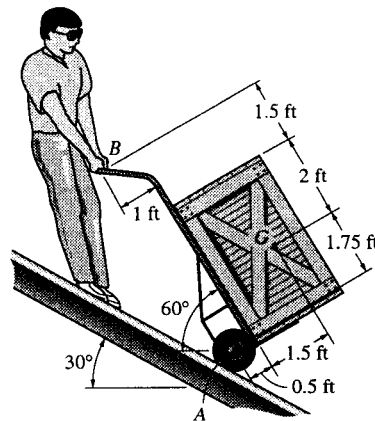

$$\curvearrowleft +\Sigma M_B = 0; \quad (N_A \cos 30^\circ)(5.25) + N_A \sin 30^\circ(0.5)$$

$$- 100 \sin 30^\circ(3.5) - 100 \cos 30^\circ(2.5) = 0$$

$$N_A = 81.621 \text{ lb} = 81.6 \text{ lb} \quad \text{Ans}$$

$$+\searrow \Sigma F_x = 0; \quad -B_x + 100 \cos 30^\circ - 81.621 \sin 30^\circ = 0$$

$$B_x = 45.792 \text{ lb}$$

$$\nearrow +\Sigma F_y = 0; \quad B_y - 100 \sin 30^\circ + 81.621 \cos 30^\circ = 0$$

$$B_y = -20.686 \text{ lb}$$

$$F_B = \sqrt{(45.792)^2 + (-20.686)^2} = 50.2 \text{ lb} \quad \text{Ans}$$

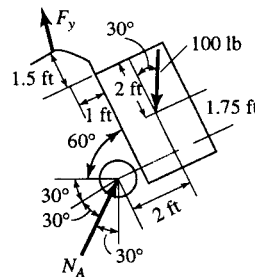

*5-40. The beam is subjected to the two concentrated loads as shown. Assuming that the foundation exerts a linearly varying load distribution on its bottom, determine the load intensities w_1 and w_2 for equilibrium (a) in terms of the parameters shown; (b) set $P = 500$ lb, $L = 12$ ft.

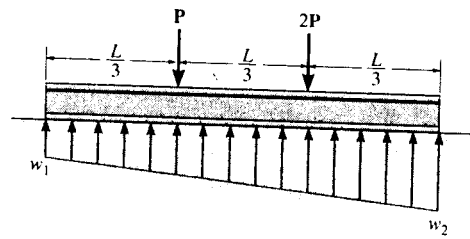

Equations of Equilibrium: The load intensity w_1 can be determined directly by summing moments about point A.

$$\begin{aligned} \left(+ \Sigma M_A = 0; \right. & P\left(\frac{L}{3}\right) - w_1 L\left(\frac{L}{6}\right) = 0 \\ & w_1 = \frac{2P}{L} \quad \text{Ans} \end{aligned}$$

$$\begin{aligned} + \uparrow \Sigma F_y = 0; & \frac{1}{2}\left(w_2 - \frac{2P}{L}\right)L + \frac{2P}{L}(L) - 3P = 0 \\ & w_2 = \frac{4P}{L} \quad \text{Ans} \end{aligned}$$

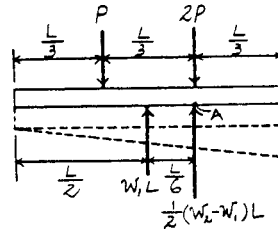

If $P = 500$ lb and $L = 12$ ft,

$$w_1 = \frac{2(500)}{12} = 83.3 \text{ lb/ft} \quad \text{Ans}$$

$$w_2 = \frac{4(500)}{12} = 167 \text{ lb/ft} \quad \text{Ans}$$

5-41. The shelf supports the electric motor which has a mass of 15 kg and mass center at G_m . The platform upon which it rests has a mass of 4 kg and mass center at G_p . Assuming that a single bolt B holds the shelf up and the bracket bears against the smooth wall at A , determine this normal force at A and the horizontal and vertical components of reaction of the bolt on the bracket.

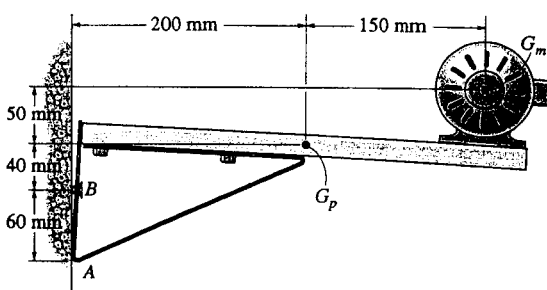

$$\left(+ \Sigma M_A = 0; \right.$$

$$B_x(60) - 4(9.81)(200) - 15(9.81)(350) = 0$$

$$B_x = 989.18 = 989 \text{ N} \quad \text{Ans}$$

$$\rightarrow \Sigma F_x = 0;$$

$$A_x = 989.18 = 989 \text{ N} \quad \text{Ans}$$

$$+ \uparrow \Sigma F_y = 0;$$

$$B_y = 4(9.81) + 15(9.81)$$

$$B_y = 186.39 = 186 \text{ N} \quad \text{Ans}$$

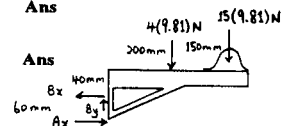

5-42. A cantilever beam, having an extended length of 3 m, is subjected to a vertical force of 500 N. Assuming that the wall resists this load with linearly varying distributed loads over the 0.15-m length of the beam portion inside the wall, determine the intensities w_1 and w_2 for equilibrium.

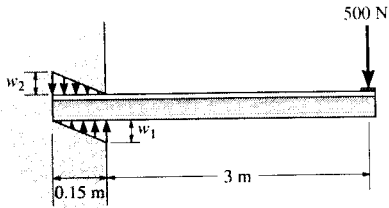

$$+\uparrow \Sigma F_y = 0; \quad \frac{1}{2}(w_1)(0.15) - \frac{1}{2}(w_2)(0.15) - 500 = 0$$

$$\begin{aligned} \curvearrowleft +\Sigma M_A = 0; \quad & -(500)3 - \frac{1}{2}(w_1)(0.15)(0.05) + \frac{1}{2}(w_2) \\ & (0.15)(0.1) = 0 \end{aligned}$$

These equations become

$$w_1 - w_2 = 6666.7$$

$$2w_2 - w_1 = 400000$$

Solving,

$$w_1 = 413 \text{ kN/m} \quad \text{Ans}$$

$$w_2 = 407 \text{ kN/m} \quad \text{Ans}$$

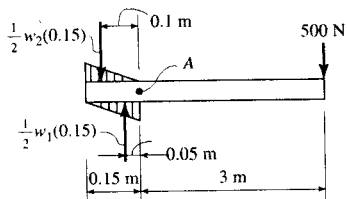

5-43. The upper portion of the crane boom consists of the jib AB , which is supported by the pin at A , the guy line BC , and the backstay CD , each cable being separately attached to the mast at C . If the 5-kN load is supported by the hoist line, which passes over the pulley at B , determine the magnitude of the resultant force the pin exerts on the jib at A for equilibrium, the tension in the guy line BC , and the tension T in the hoist line. Neglect the weight of the jib. The pulley at B has a radius of 0.1 m.

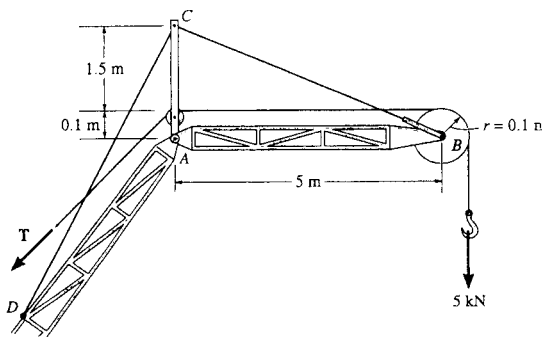

From pulley, tension in the hoist line is

$$\curvearrowleft + \Sigma M_B = 0; \quad T(0.1) - 5(0.1) = 0;$$

$$T = 5 \text{ kN} \quad \text{Ans}$$

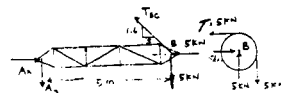

From the jib,

$$\curvearrowleft + \Sigma M_A = 0; \quad -5(5) + T_{BC} \left(\frac{1.6}{\sqrt{27.56}} \right) (5) = 0$$

$$T_{BC} = 16.4055 = 16.4 \text{ kN} \quad \text{Ans}$$

$$+\uparrow \Sigma F_y = 0; \quad -A_y + (16.4055) \left(\frac{1.6}{\sqrt{27.56}} \right) - 5 = 0$$

$$A_y = 0$$

$$\rightarrow \Sigma F_x = 0; \quad A_x - 16.4055 \left(\frac{5}{\sqrt{27.56}} \right) - 5 = 0$$

$$F_A = A_x = 20.6 \text{ kN} \quad \text{Ans}$$

*5-44. The mobile crane has a weight of 120,000 lb and center of gravity at G_1 ; the boom has a weight of 30,000 lb and center of gravity at G_2 . Determine the smallest angle of tilt θ of the boom, without causing the crane to overturn if the suspended load is $W = 40,000$ lb. Neglect the thickness of the tracks at A and B .

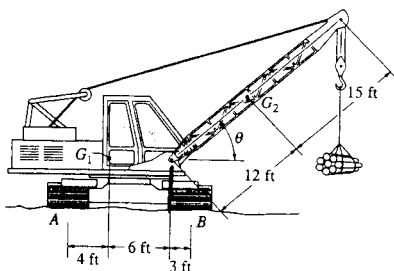

When tipping occurs, $R_A = 0$

$$\curvearrowleft + \Sigma M_B = 0; \quad -(30\,000)(12 \cos \theta - 3) - (40\,000)(27 \cos \theta - 3) + (120\,000)(9) = 0$$

$$\theta = \cos^{-1}(0.896) = 26.4^\circ \quad \text{Ans}$$

5-45. The mobile crane has a weight of 120,000 lb and center of gravity at G_1 ; the boom has a weight of 30,000 lb and center of gravity at G_2 . If the suspended load has a weight of $W = 16,000$ lb, determine the normal reactions at the tracks A and B . For the calculation, neglect the thickness of the tracks and take $\theta = 30^\circ$.

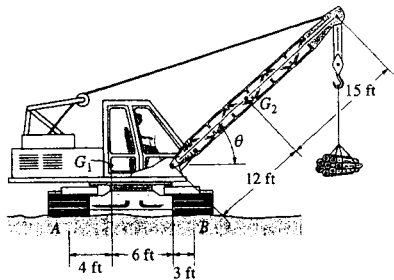
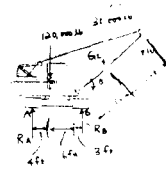

$$+\circlearrowleft \Sigma M_B = 0; \quad -(30\,000)(12 \cos 30^\circ - 3) - (16\,000)(27 \cos 30^\circ - 3) - R_A(13) + (120\,000)(9) = 0$$

$$R_A = 40\,931 \text{ lb} = 40.9 \text{ kip} \quad \text{Ans}$$

$$+\uparrow \Sigma F_y = 0; \quad 40\,931 + R_B - 120\,000 - 30\,000 - 16\,000 = 0$$

$$R_B = 125 \text{ kip} \quad \text{Ans}$$

5-46. The winch consists of a drum radius 4 in., which is pin-connected at its center C . At its outer rim is a ratchet gear having a mean radius of 6 in. The pawl AB serves as a two-force member (short link) and holds the drum from rotating. If the suspended load is 500 lb, determine the horizontal and vertical components of reaction at the pin C .

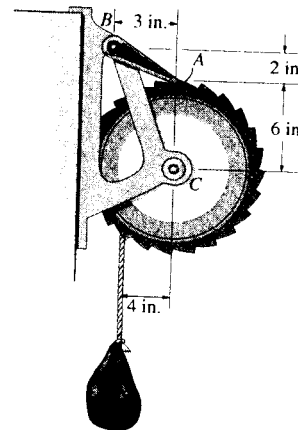

Equations of Equilibrium: The force in short link AB can be obtained directly by summing moments about point C .

$$+\circlearrowleft \Sigma M_C = 0; \quad 500(4) - F_{AB} \left(\frac{3}{\sqrt{13}} \right) (6) = 0 \quad F_{AB} = 400.62 \text{ lb}$$

$$\begin{aligned} \rightarrow \Sigma F_x = 0; \quad 400.62 \left(\frac{3}{\sqrt{13}} \right) - C_x = 0 \\ C_x = 333 \text{ lb} \quad \text{Ans} \end{aligned}$$

$$\begin{aligned} +\uparrow \Sigma F_y = 0; \quad C_y - 500 - 400.62 \left(\frac{2}{\sqrt{13}} \right) = 0 \\ C_y = 722 \text{ lb} \quad \text{Ans} \end{aligned}$$

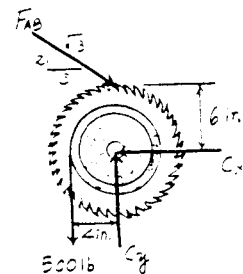

5-47. The crane consists of three parts, which have weights of $W_1 = 3500$ lb, $W_2 = 900$ lb, $W_3 = 1500$ lb and centers of gravity at G_1 , G_2 , and G_3 , respectively. Neglect the weight of the boom, determine (a) the reactions on each of the four tires if the load is hoisted at constant velocity and has a weight of 800 lb, and (b), with the boom held in the position shown, the maximum load the crane can lift without tipping over.

Equations of Equilibrium: The normal reaction N_B can be obtained directly by summing moments about point A.

$$\begin{aligned} \zeta + \Sigma M_A = 0; \quad & 2N_B(17) + W(10) - 3500(3) \\ & - 900(11) - 1500(18) = 0 \\ N_B = & 1394.12 - 0.2941W \end{aligned} \quad [1]$$

Using the result $N_B = 2788.24 - 0.5882W$,

$$\begin{aligned} + \uparrow \Sigma F_y = 0; \quad & 2N_A + (2788.24 - 0.5882W) - W \\ & - 3500 - 900 - 1500 = 0 \\ N_A = & 0.7941W + 1555.88 \end{aligned} \quad [2]$$

a) Set $W = 800$ lb and substitute into Eqs. [1] and [2] yields

$$\begin{aligned} N_A &= 0.7941(800) + 1555.88 = 2191.18 \text{ lb} = 2.19 \text{ kip} & \text{Ans} \\ N_B &= 1394.12 - 0.2941(800) = 1158.82 \text{ lb} = 1.16 \text{ kip} & \text{Ans} \end{aligned}$$

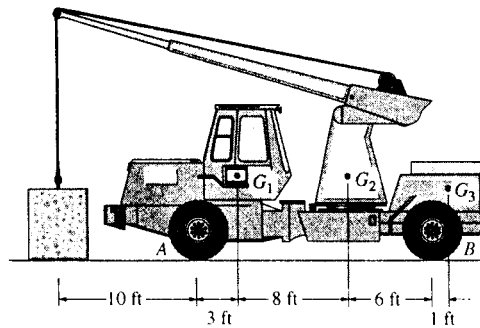

b) When the crane is about to tip over, the normal reaction on $N_C = 0$. From Eq. [1],

$$\begin{aligned} N_B = 0 &= 1394.12 - 0.2941W \\ W &= 4740 \text{ lb} = 4.74 \text{ kip} \end{aligned} \quad \text{Ans}$$

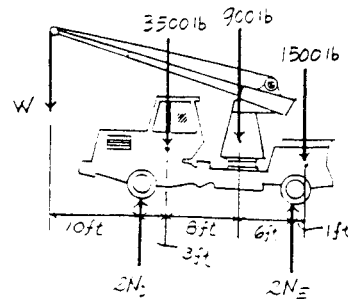

*5-48. The boom supports the two vertical loads. Neglect the size of the collars at D and B and the thickness of the boom, and compute the horizontal and vertical components of force at the pin A and the force in cable CB. Set $F_1 = 800$ N and $F_2 = 350$ N.

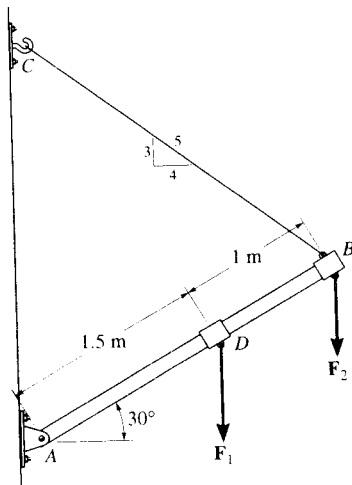

$$\begin{aligned} \zeta + \Sigma M_A = 0; \quad & -800(1.5 \cos 30^\circ) - 350(2.5 \cos 30^\circ) \\ & + \frac{4}{5}F_{CB}(2.5 \sin 30^\circ) + \frac{3}{5}F_{CB}(2.5 \cos 30^\circ) = 0 \end{aligned}$$

$$F_{CB} = 781.6 = 782 \text{ N} \quad \text{Ans}$$

$$\rightarrow \Sigma F_x = 0; \quad A_x - \frac{4}{5}(781.6) = 0$$

$$A_x = 625 \text{ N} \quad \text{Ans}$$

$$+ \uparrow \Sigma F_y = 0; \quad A_y - 800 - 350 + \frac{3}{5}(781.6) = 0$$

$$A_y = 681 \text{ N} \quad \text{Ans}$$

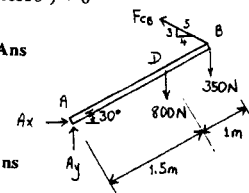

5-49. The boom is intended to support two vertical loads, F_1 and F_2 . If the cable CB can sustain a maximum load of 1500 lb before it fails, determine the critical loads if $F_1 = 2F_2$. Also, what is the magnitude of the maximum reaction at pin A ?

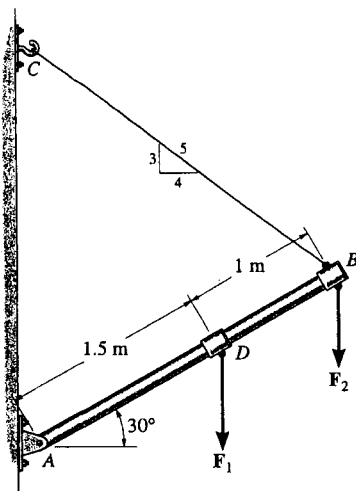

$$+\circlearrowleft \Sigma M_A = 0;$$

$$-2F_2(1.5 \cos 30^\circ) - F_2(2.5 \cos 30^\circ) + \frac{4}{5}(1500)(2.5 \sin 30^\circ) + \frac{3}{5}(1500)(2.5 \cos 30^\circ) = 0$$

$$F_2 = 724 \text{ lb} \quad \text{Ans}$$

$$F_1 = 2F_2 = 1448 \text{ lb}$$

$$F_1 = 1.45 \text{ kip} \quad \text{Ans}$$

$$+\rightarrow \Sigma F_x = 0;$$

$$A_x - \frac{4}{5}(1500) = 0$$

$$A_x = 1200 \text{ lb}$$

$$+\uparrow \Sigma F_y = 0;$$

$$A_y - 724 - 1448 + \frac{3}{5}(1500) = 0$$

$$A_y = 1272 \text{ lb}$$

$$F_A = \sqrt{(1200)^2 + (1272)^2} = 1749 \text{ lb} = 1.75 \text{ kip} \quad \text{Ans}$$

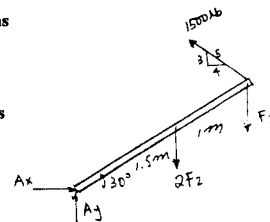

5-50. Three uniform books, each having a weight W and length a , are stacked as shown. Determine the maximum distance d that the top book can extend out from the bottom one so the stack does not topple over.

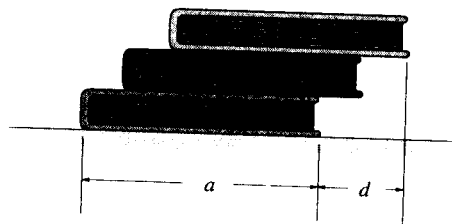

Equilibrium: For top two books, the upper book will topple when the center of gravity of this book is to the right of point A . Therefore, the maximum distance from the right edge of this book to point A is $a/2$.

Equation of Equilibrium: For the entire three books, the top two books will topple about point B .

$$+\circlearrowleft \Sigma M_B = 0; \quad W(a-d) - W\left(d - \frac{a}{2}\right) = 0$$

$$d = \frac{3a}{4}$$

Ans

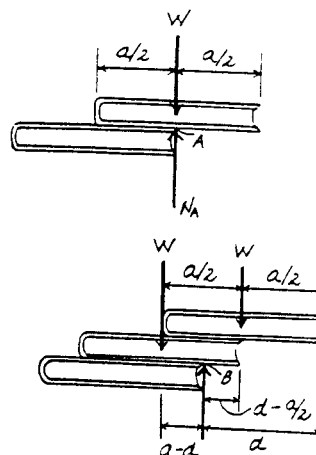

5-51. The toggle switch consists of a cocking lever that is pinned to a fixed frame at A and held in place by the spring which has an unstretched length of 200 mm. Determine the magnitude of the resultant force at A and the normal force on the peg at B when the lever is in the position shown.

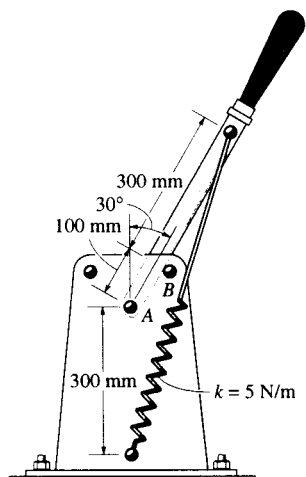

$$l = \sqrt{(0.3)^2 + (0.4)^2 - 2(0.3)(0.4)\cos 150^\circ} = 0.67664 \text{ m}$$

$$\frac{\sin \theta}{0.3} = \frac{\sin 150^\circ}{0.67664}; \quad \theta = 12.808^\circ$$

$$F_s = ks = 5(0.67664 - 0.2) = 2.3832 \text{ N}$$

$$\sum M_A = 0; \quad -(2.3832 \sin 12.808^\circ)(0.4) + N_B(0.1) = 0$$

$$N_B = 2.11327 \text{ N} = 2.11 \text{ N} \quad \text{Ans}$$

$$\sum F_x = 0; \quad A_x - 2.3832 \cos 12.808^\circ = 0$$

$$A_x = 2.3239 \text{ N}$$

$$\sum F_y = 0; \quad A_y + 2.11327 - 2.3832 \sin 12.808^\circ = 0$$

$$A_y = -1.5850 \text{ N}$$

$$F_A = \sqrt{(2.3239)^2 + (-1.5850)^2} = 2.81 \text{ N} \quad \text{Ans}$$

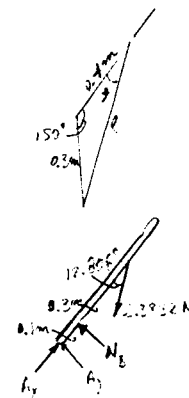

*5-52. The rigid beam of negligible weight is supported horizontally by two springs and a pin. If the springs are uncompressed when the load is removed, determine the force in each spring when the load P is applied. Also, compute the vertical deflection of end C. Assume the spring stiffness k is large enough so that only small deflections occur. Hint: The beam rotates about A so the deflections in the springs can be related.

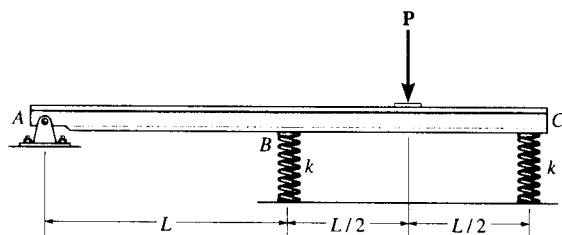

$$\sum M_A = 0;$$

$$F_B(L) + F_C(2L) - P\left(\frac{3}{2}L\right) = 0$$

$$F_B + 2F_C = 1.5P$$

$$\frac{L}{\Delta_B} = \frac{2L}{\Delta_C}$$

$$\Delta_C = 2\Delta_B$$

$$\frac{F_C}{k} = \frac{2F_B}{k}$$

$$F_C = 2F_B$$

$$5F_B = 1.5P$$

$$F_B = 0.3P \quad \text{Ans}$$

$$F_C = 0.6P \quad \text{Ans}$$

Deflection

$$x_C = \frac{0.6P}{k} \quad \text{Ans}$$

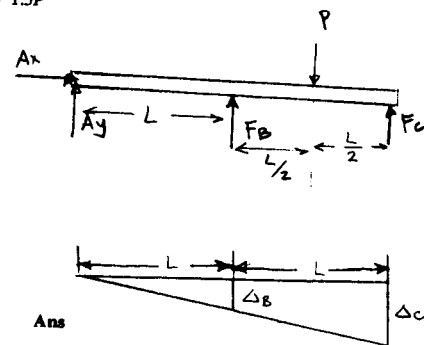

5-53. The uniform rod AB has a weight of 15 lb and the spring is unstretched when $\theta = 0^\circ$. If $\theta = 30^\circ$, determine the stiffness k of the spring.

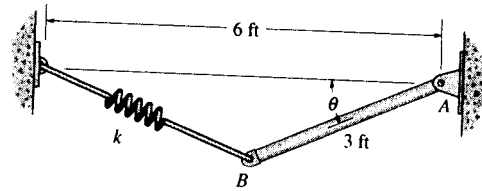

Geometry : From triangle CDE , the cosine law gives

$$l = \sqrt{2.536^2 + 1.732^2 - 2(2.536)(1.732) \cos 120^\circ} = 3.718 \text{ ft}$$

Using the sine law,

$$\frac{\sin \alpha}{2.536} = \frac{\sin 120^\circ}{3.718} \quad \alpha = 36.21^\circ$$

Equations of Equilibrium : The force in the spring can be obtained directly by summing moments about point A .

$$\begin{aligned} \zeta + \Sigma M_A = 0; \quad & 15 \cos 30^\circ (1.5) - F_{sp} \cos 36.21^\circ (3) = 0 \\ & F_{sp} = 8.050 \text{ lb} \end{aligned}$$

Spring Force Formula : The spring stretches $x = 3.718 - 3 = 0.718 \text{ ft}$

$$k = \frac{F_{sp}}{x} = \frac{8.050}{0.718} = 11.2 \text{ lb/ft} \quad \text{Ans}$$

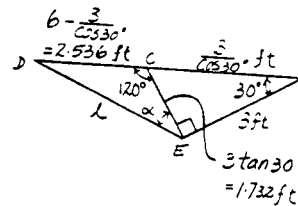
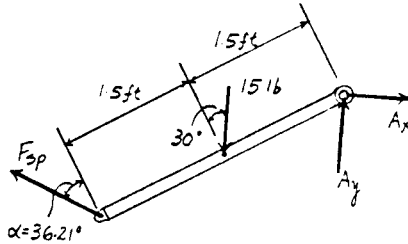

5-54. The smooth pipe rests against the wall at the points of contact A , B , and C . Determine the reactions at these points needed to support the vertical force of 45 lb. Neglect the pipe's thickness in the calculation.

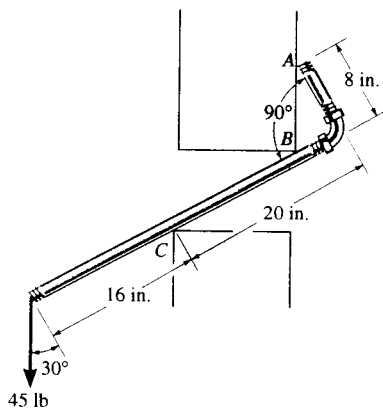

$$\zeta + \Sigma M_A = 0; \quad 45 \cos 30^\circ (36) - 45 \sin 30^\circ (8) - R_C (20) + R_B (8 \tan 30^\circ) = 0$$

$$+ \uparrow \Sigma F_y = 0; \quad R_C \cos 30^\circ - R_B \cos 30^\circ - 45 = 0$$

$$R_C = 63.91 = 63.9 \text{ lb} \quad \text{Ans}$$

$$R_B = 11.95 = 11.9 \text{ lb} \quad \text{Ans}$$

$$\rightarrow \Sigma F_x = 0; \quad R_A + 11.95 \sin 30^\circ - 63.91 \sin 30^\circ = 0$$

$$R_A = 26.0 \text{ lb} \quad \text{Ans}$$

Also,

$$+ \Sigma F_x = 0; \quad 45 \sin 30^\circ - R_A \cos 30^\circ = 0$$

$$R_A = 26.0 \text{ lb} \quad \text{Ans}$$

$$+ \Sigma F_y = 0; \quad -45 \cos 30^\circ + R_C - R_B - 25.98 \sin 30^\circ = 0$$

$$\zeta + \Sigma M_C = 0; \quad 45 \cos 30^\circ (16) - R_B (20 - 8 \tan 30^\circ) - 25.98 (8 \cos 30^\circ + 20 \sin 30^\circ) = 0$$

$$R_B = 11.9 \text{ lb} \quad \text{Ans}$$

$$R_C = 63.9 \text{ lb} \quad \text{Ans}$$

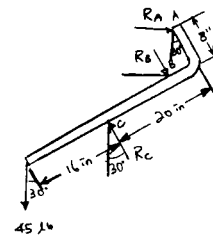

***5-55.** The horizontal beam is supported by springs at its ends. Each spring has a stiffness of $k = 5 \text{ kN/m}$ and is originally unstretched so that the beam is in the horizontal position. Determine the angle of tilt of the beam if a load of 800 N is applied at point C as shown.

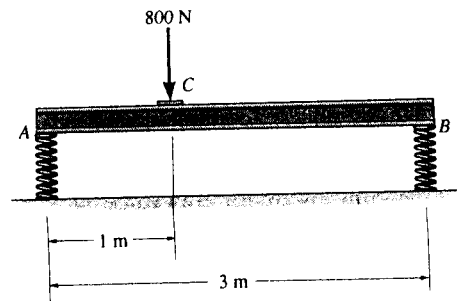

Equations of Equilibrium : The spring force at A and B can be obtained directly by summing moments about points B and A , respectively.

$$\left(+ \Sigma M_B = 0; \quad 800(2) - F_A(3) = 0 \quad F_A = 533.33 \text{ N} \right.$$

$$\left(+ \Sigma M_A = 0; \quad F_B(3) - 800(1) = 0 \quad F_B = 266.67 \text{ N} \right.$$

Spring Formula : Applying $\Delta = \frac{F}{k}$, we have

$$\Delta_A = \frac{533.33}{5(10^3)} = 0.1067 \text{ m}$$

$$\Delta_B = \frac{266.67}{5(10^3)} = 0.05333 \text{ m}$$

Geometry : The angle of tilt α is

$$\alpha = \tan^{-1}\left(\frac{0.05333}{3}\right) = 1.02^\circ \quad \text{Ans}$$

***5-56.** The horizontal beam is supported by springs at its ends. If the stiffness of the spring at A is $k_A = 5 \text{ kN/m}$, determine the required stiffness of the spring at B so that if the beam is loaded with the 800 N it remains in the horizontal position. The springs are originally constructed so that the beam is in the horizontal position when it is unloaded.

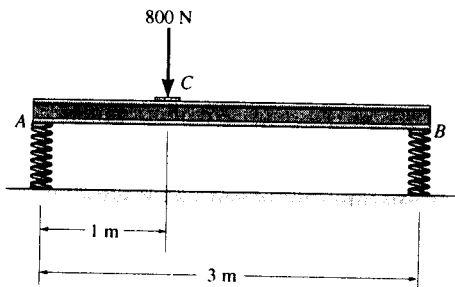

Equations of Equilibrium : The spring forces at A and B can be obtained directly by summing moments about points B and A respectively.

$$\left(+ \Sigma M_B = 0; \quad 800(2) - F_A(3) = 0 \quad F_A = 533.33 \text{ N} \right.$$

$$\left(+ \Sigma M_A = 0; \quad F_B(3) - 800(1) = 0 \quad F_B = 266.67 \text{ N} \right.$$

Spring Formula : Applying $\Delta = \frac{F}{k}$, we have

$$\Delta_A = \frac{533.33}{5(10^3)} = 0.1067 \text{ m} \quad \Delta_B = \frac{266.67}{k_B}$$

Geometry : Requires, $\Delta_B = \Delta_A$. Then

$$\frac{266.67}{k_B} = 0.1067$$

$$k_B = 2500 \text{ N/m} = 2.50 \text{ kN/m} \quad \text{Ans}$$

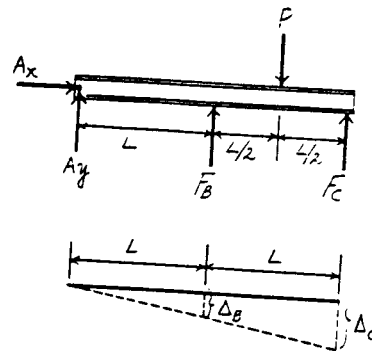

5-57. Determine the distance d for placement of the load P for equilibrium of the smooth bar in the position θ as shown. Neglect the weight of the bar.

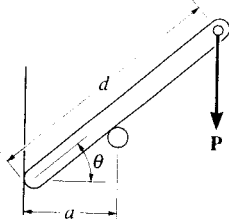

$$+\uparrow \Sigma F_y = 0;$$

$$R \cos \theta - P = 0$$

$$(+\Sigma M_A = 0;$$

$$-P(d \cos \theta) + R\left(\frac{a}{\cos \theta}\right) = 0$$

$$Rd \cos^2 \theta = R\left(\frac{a}{\cos \theta}\right)$$

$$d = \frac{a}{\cos^3 \theta} \quad \text{Ans}$$

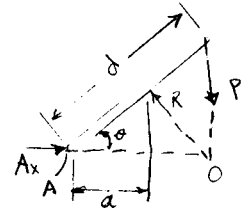

Also;

Require forces to be concurrent at point O .

$$AO = d \cos \theta = \frac{a/\cos \theta}{\cos \theta}$$

thus

$$d = \frac{a}{\cos^3 \theta} \quad \text{Ans}$$

5-58. The wheelbarrow and its contents have a mass m and center of mass at G . Determine the greatest angle of tilt θ without causing the wheelbarrow to tip over.

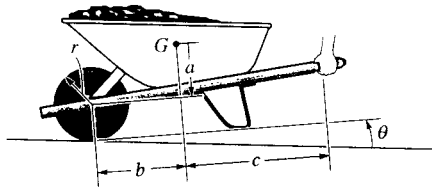

Require point G to be over the wheel axle for tipping. Thus

$$b \cos \theta = a \sin \theta$$

$$\theta = \tan^{-1} \frac{b}{a} \quad \text{Ans}$$

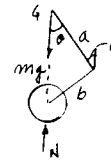

5-59. A man stands out at the end of the diving board, which is supported by two springs *A* and *B*, each having a stiffness of $k = 15 \text{ kN/m}$. In the position shown the board is horizontal. If the man has a mass of 40 kg , determine the angle of tilt which the board makes with the horizontal after he jumps off. Neglect the weight of the board and assume it is rigid.

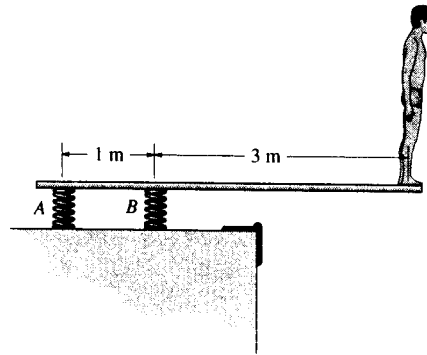

Equations of Equilibrium : The spring force at *A* and *B* can be obtained directly by summing moments about points *B* and *A*, respectively.

$$\left(+ \Sigma M_B = 0; \quad F_A (1) - 392.4(3) = 0 \quad F_A = 1177.2 \text{ N} \right.$$

$$\left(+ \Sigma M_A = 0; \quad F_B (1) - 392.4(4) = 0 \quad F_B = 1569.6 \text{ N} \right.$$

Spring Formula : Applying $\Delta = \frac{F}{k}$, we have

$$\Delta_A = \frac{1177.2}{15(10^3)} = 0.07848 \text{ m} \quad \Delta_B = \frac{1569.6}{15(10^3)} = 0.10464 \text{ m}$$

Geometry : The angle of tilt α is

$$\alpha = \tan^{-1} \left(\frac{0.10464 + 0.07848}{1} \right) = 10.4^\circ \quad \text{Ans}$$

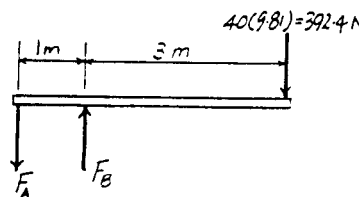

*5-60. The uniform beam has a weight W and length l and is supported by a pin at *A* and a cable *BC*. Determine the horizontal and vertical components of reaction at *A* and the tension in the cable necessary to hold the beam in the position shown.

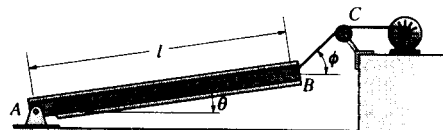

Equations of Equilibrium : The tension the cable can be obtained directly by summing moments about point *A*.

$$\left(+ \Sigma M_A = 0; \quad T \sin(\phi - \theta) l - W \cos \theta \left(\frac{l}{2} \right) = 0 \right.$$

$$T = \frac{W \cos \theta}{2 \sin(\phi - \theta)} \quad \text{Ans}$$

Using the result $T = \frac{W \cos \theta}{2 \sin(\phi - \theta)}$

$$\rightarrow \Sigma F_x = 0; \quad \left(\frac{W \cos \theta}{2 \sin(\phi - \theta)} \right) \cos \phi - A_x = 0$$

$$A_x = \frac{W \cos \phi \cos \theta}{2 \sin(\phi - \theta)} \quad \text{Ans}$$

$$+\uparrow \Sigma F_y = 0; \quad A_y + \left(\frac{W \cos \theta}{2 \sin(\phi - \theta)} \right) \sin \phi - W = 0$$

$$A_y = \frac{W(\sin \phi \cos \theta - 2 \cos \phi \sin \theta)}{2 \sin(\phi - \theta)} \quad \text{Ans}$$

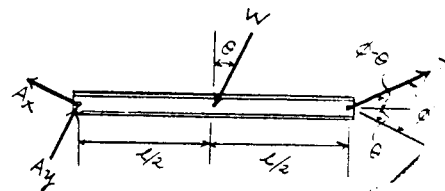

5-61. The uniform rod has a length l and weight W . It is supported at one end A by a smooth wall and the other end by a cord of length s which is attached to the wall as shown. Show that for equilibrium it is required that $h = [(s^2 - l^2)/3]^{1/2}$.

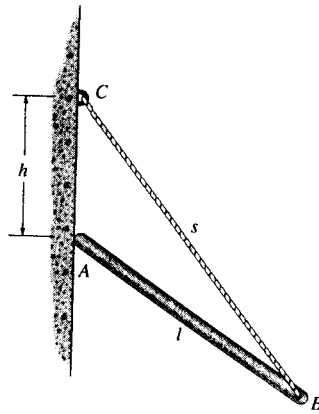

Equations of Equilibrium: The tension in the cable can be obtained directly by summing moments about point A .

$$\begin{aligned} \sum M_A = 0; \quad T \sin \phi (l) - W \sin \theta \left(\frac{l}{2}\right) &= 0 \\ T &= \frac{W \sin \theta}{2 \sin \phi} \end{aligned}$$

Using the result $T = \frac{W \sin \theta}{2 \sin \phi}$,

$$\begin{aligned} + \uparrow \sum F_y = 0; \quad \frac{W \sin \theta}{2 \sin \phi} \cos(\theta - \phi) - W &= 0 \\ \sin \theta \cos(\theta - \phi) - 2 \sin \phi &= 0 \end{aligned} \quad [1]$$

Geometry: Applying the sine law with $\sin(180^\circ - \theta) = \sin \theta$, we have

$$\frac{\sin \phi}{h} = \frac{\sin \theta}{s} \quad \sin \phi = \frac{h}{s} \sin \theta \quad [2]$$

Substituting Eq. [2] into [1] yields

$$\cos(\theta - \phi) = \frac{2h}{s} \quad [3]$$

Using the cosine law,

$$\begin{aligned} l^2 &= h^2 + s^2 - 2hs \cos(\theta - \phi) \\ \cos(\theta - \phi) &= \frac{h^2 + s^2 - l^2}{2hs} \end{aligned} \quad [4]$$

Equating Eqs. [3] and [4] yields

$$\begin{aligned} \frac{2h}{s} &= \frac{h^2 + s^2 - l^2}{2hs} \\ h &= \sqrt{\frac{s^2 - l^2}{3}} \quad (Q. E. D) \end{aligned}$$

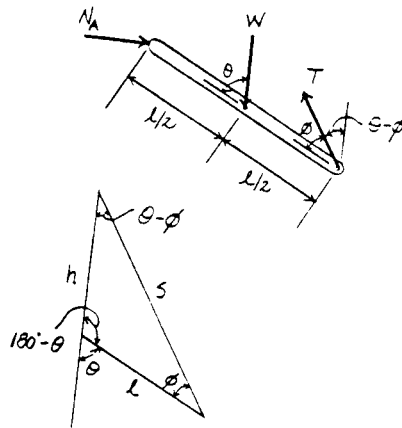

5-62. The disk has a mass of 20 kg and is supported on the smooth cylindrical surface by a spring having a stiffness of $k = 400 \text{ N/m}$ and unstretched length of $l_0 = 1 \text{ m}$. The spring remains in the horizontal position since its end A is attached to the small roller guide which has negligible weight. Determine the angle θ to the nearest degree for equilibrium of the roller.

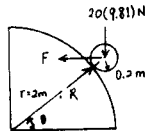
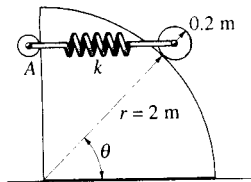

$$+\uparrow \Sigma F_y = 0; \quad R \sin \theta - 20(9.81) = 0$$

$$\rightarrow \Sigma F_x = 0; \quad R \cos \theta - F = 0$$

$$\tan \theta = \frac{20(9.81)}{F}$$

$$\text{Since } \cos \theta = \frac{1.0 + \frac{F}{400}}{2.2}$$

$$2.2 \cos \theta = 1.0 + \frac{20(9.81)}{400 \tan \theta}$$

$$880 \sin \theta = 400 \tan \theta + 20(9.81)$$

Solving,

$$\theta = 27.1^\circ \text{ and } \theta = 50.2^\circ \quad \text{Ans}$$

5-63. The uniform load has a mass of 600 kg and is lifted using a uniform 30-kg strongback beam and four wire ropes as shown. Determine the tension in each segment of rope and the force that must be applied to the sling at A .

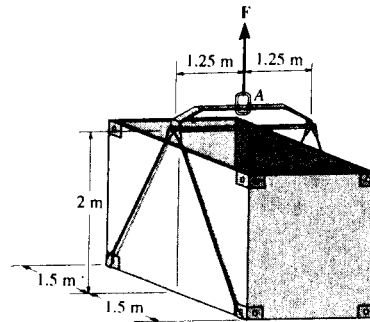

Prob. 5-63

Equations of Equilibrium: Due to symmetry, all wires are subjected to the same tension. This condition satisfies moment equilibrium about the x and y axes and force equilibrium along y axis.

$$\Sigma F_z = 0; \quad 4T \left(\frac{4}{5} \right) - 5886 = 0$$

$$T = 1839.375 \text{ N} = 1.84 \text{ kN} \quad \text{Ans}$$

The force F applied to the sling A must support the weight of the load and strongback beam. Hence

$$\Sigma F_z = 0; \quad F - 600(9.81) - 30(9.81) = 0$$

$$F = 6180.3 \text{ N} = 6.18 \text{ kN} \quad \text{Ans}$$

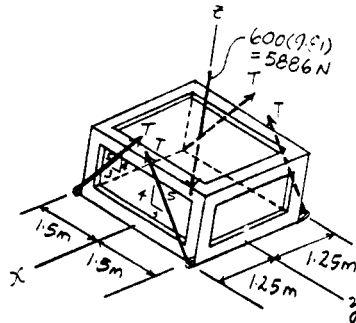

*5-64. The wing of the jet aircraft is subjected to a thrust of $T = 8 \text{ kN}$ from its engine and the resultant lift force $L = 45 \text{ kN}$. If the mass of the wing is 2.1 Mg and the mass center is at G , determine the x, y, z components of reaction where the wing is fixed to the fuselage at A .

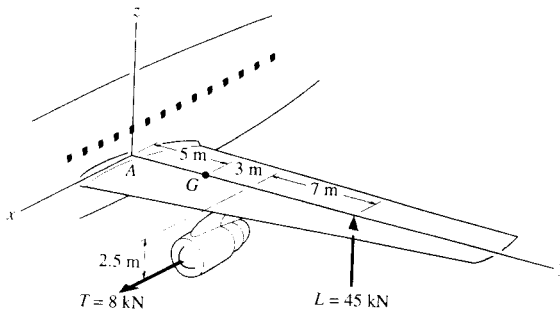

$$\begin{aligned} \Sigma F_x = 0; & \quad -A_x + 8000 = 0 \\ & \quad A_x = 8.00 \text{ kN} \quad \text{Ans} \\ \Sigma F_y = 0; & \quad A_y = 0 \quad \text{Ans} \\ \Sigma F_z = 0; & \quad -A_z - 20\,601 + 45\,000 = 0 \\ & \quad A_z = 24.4 \text{ kN} \quad \text{Ans} \\ \Sigma M_x = 0; & \quad M_x - 2.5(8000) = 0 \\ & \quad M_x = 20.0 \text{ kN}\cdot\text{m} \quad \text{Ans} \\ \Sigma M_y = 0; & \quad 45\,000(15) - 20\,601(5) - M_y = 0 \\ & \quad M_y = 572 \text{ kN}\cdot\text{m} \quad \text{Ans} \\ \Sigma M_z = 0; & \quad M_z - 8000(8) = 0 \\ & \quad M_z = 64.0 \text{ kN}\cdot\text{m} \quad \text{Ans} \end{aligned}$$

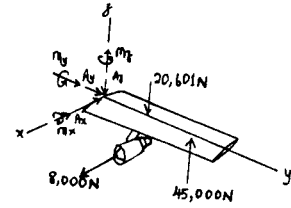

5-65. The uniform concrete slab has a weight of 5500 lb . Determine the tension in each of the three parallel supporting cables when the slab is held in the horizontal plane as shown.

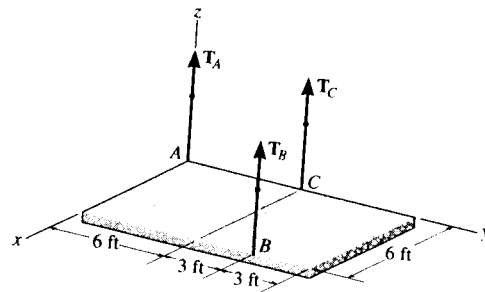

Equations of Equilibrium: The cable tension T_B can be obtained directly by summing moments about the y axis.

$$\Sigma M_y = 0; \quad 5.50(3) - T_B(6) = 0 \quad T_B = 2.75 \text{ kip} \quad \text{Ans}$$

$$\Sigma M_x = 0; \quad T_C(6) + 2.75(9) - 5.50(6) = 0 \\ T_C = 1.375 \text{ kip} \quad \text{Ans}$$

$$\Sigma F_z = 0; \quad T_A + 2.75 + 1.375 - 5.50 = 0 \\ T_A = 1.375 \text{ kip} \quad \text{Ans}$$

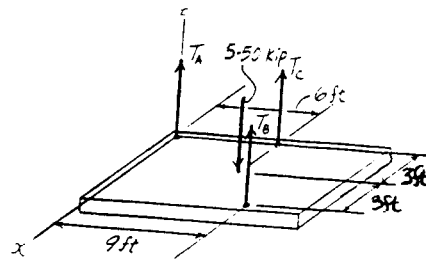

5-66. The air-conditioning unit is hoisted to the roof of a building using the three cables. If the tensions in the cables are $T_A = 250$ lb, $T_B = 300$ lb, and $T_C = 200$ lb, determine the weight of the unit and the location (x, y) of its center of gravity G .

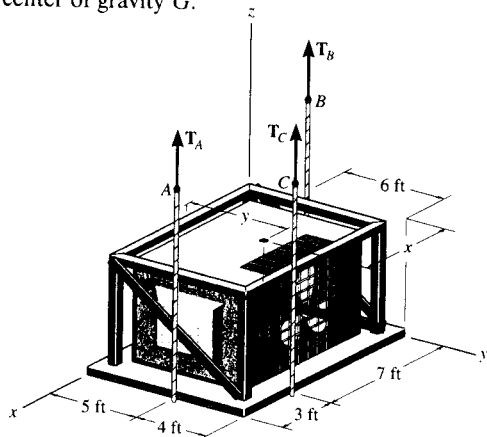

$$\begin{aligned} \Sigma F_z = 0; & \quad 250 + 300 + 200 - W = 0 \\ & \quad W = 750 \text{ lb} \quad \text{Ans} \\ \Sigma M_y = 0; & \quad 750(x) - 250(10) - 200(7) = 0 \\ & \quad x = 5.20 \text{ ft} \quad \text{Ans} \\ \Sigma M_x = 0; & \quad 250(5) + 300(3) + 200(9) - 750(y) = 0 \\ & \quad y = 5.27 \text{ ft} \quad \text{Ans} \end{aligned}$$

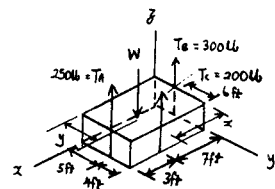

5-67. The platform truck supports the three loadings shown. Determine the normal reactions on each of its three wheels.

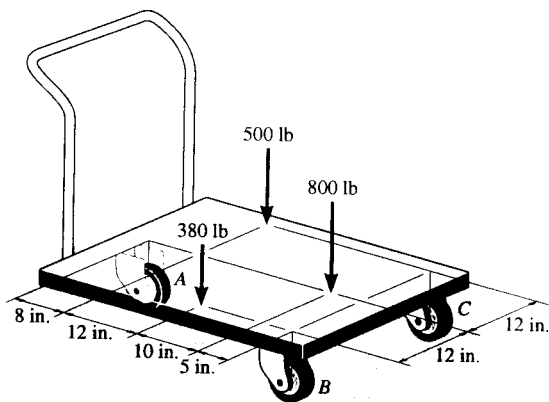

$$\Sigma M_x = 0; \quad 380(15) + 500(27) + 800(5) - F_A(35) = 0$$

$$F_A = 662.8571 = 663 \text{ lb} \quad \text{Ans}$$

$$\Sigma M_y = 0; \quad 380(12) - F_B(12) - 500(12) + F_C(12)$$

$$F_C - F_B = 120$$

$$\Sigma F_z = 0; \quad F_B + F_C - 500 + 663 - 380 - 800 = 0$$

$$F_B + F_C = 1017.1429$$

Solving,

$$F_C = 569 \text{ lb} \quad \text{Ans}$$

$$F_B = 449 \text{ lb} \quad \text{Ans}$$

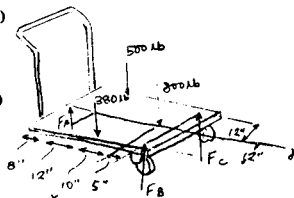

***5-68.** The wrench is used to tighten the bolt at *A*. If the force $F = 6$ lb is applied to the handle as shown, determine the magnitudes of the resultant force and moment that the bolt head exerts on the wrench. The force F is in a plane parallel to the $x-z$ plane.

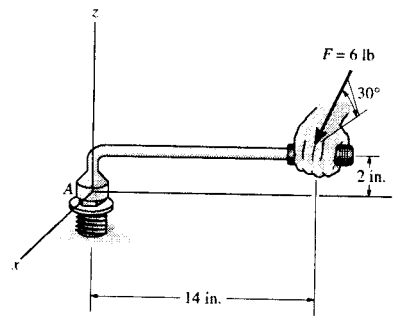

Equations of Equilibrium:

$$\Sigma F_x = 0; \quad 6 \cos 30^\circ - A_x = 0 \quad A_x = 5.196 \text{ lb}$$

$$\Sigma F_y = 0; \quad A_y = 0$$

$$\Sigma F_z = 0; \quad A_z - 6 \sin 30^\circ = 0 \quad A_z = 3.00 \text{ lb}$$

$$\Sigma M_x = 0; \quad (M_A)_x - 6 \sin 30^\circ (14) = 0 \quad (M_A)_x = 42.0 \text{ lb} \cdot \text{in}$$

$$\Sigma M_y = 0; \quad 6 \cos 30^\circ (2) - (M_A)_y = 0 \quad (M_A)_y = 10.39 \text{ lb} \cdot \text{in}$$

$$\Sigma M_z = 0; \quad (M_A)_z - 6 \cos 30^\circ (14) = 0 \quad (M_A)_z = 72.75 \text{ lb} \cdot \text{in}$$

The magnitude of force and moment reactions are

$$F_A = \sqrt{A_x^2 + A_z^2} = \sqrt{5.196^2 + 3.00^2} = 6.00 \text{ lb} \quad \text{Ans}$$

$$M_A = \sqrt{(M_A)_x^2 + (M_A)_y^2 + (M_A)_z^2}$$

$$= \sqrt{42.0^2 + 10.39^2 + 72.75^2}$$

$$= 84.64 \text{ lb} \cdot \text{in} = 7.05 \text{ lb} \cdot \text{ft} \quad \text{Ans}$$

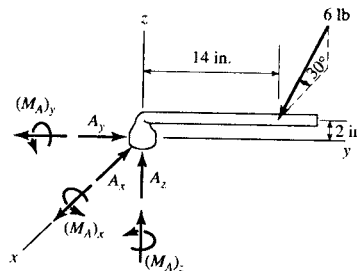

5-69. The cart supports the uniform crate having a mass of 85 kg. Determine the vertical reactions on the three casters at *A*, *B*, and *C*. The caster at *B* is not shown. Neglect the mass of the cart.

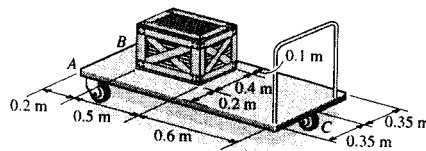

Equations of Equilibrium: The normal reaction N_C can be obtained directly by summing moments about x axis.

$$\Sigma M_x = 0; \quad N_C(1.3) - 833.85(0.45) = 0$$

$$N_C = 288.64 \text{ N} = 289 \text{ N} \quad \text{Ans}$$

$$\Sigma M_y = 0; \quad 833.85(0.3) - 288.64(0.35) - N_A(0.7) = 0$$

$$N_A = 213.04 \text{ N} = 213 \text{ N} \quad \text{Ans}$$

$$\Sigma F_z = 0; \quad N_B + 288.64 + 213.04 - 833.85 = 0$$

$$N_B = 332 \text{ N} \quad \text{Ans}$$

5-70. The boom AB is held in equilibrium by a ball-and-socket joint A and a pulley and cord system as shown. Determine the x, y, z components of reaction at A and the tension in cable DEC if $\mathbf{F} = \{-1500\mathbf{k}\}$ lb.

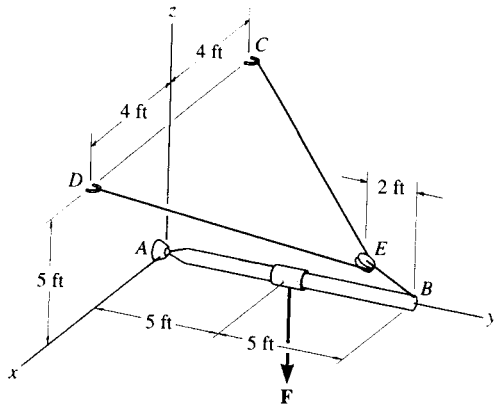

From FBD of boom,

$$\Sigma M_x = 0; \quad \frac{5}{\sqrt{125}} T_{BE}(10) - 1500(5) = 0$$

$$T_{BE} = 1677.05 \text{ lb}$$

$$\Sigma F_x = 0; \quad A_x = 0$$

$$\Sigma F_y = 0; \quad A_y - \frac{10}{\sqrt{125}}(1677.05) = 0$$

$$A_y = 1500 \text{ lb} = 1.50 \text{ kip}$$

$$\Sigma F_z = 0; \quad A_z - 1500 + \frac{5}{\sqrt{125}}(1677.05) = 0$$

$$A_z = 750 \text{ lb}$$

From FBD of pulley,

$$\Sigma F_z = 0; \quad 2\left(\frac{4}{\sqrt{96}}\right)T - \frac{1}{\sqrt{5}}(1677.05) = 0$$

$$T = 918.56 = 919 \text{ lb}$$

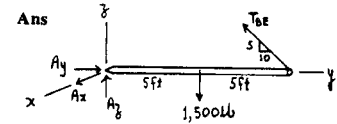

Ans

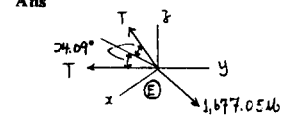

Ans

Ans

5-71. The cable CED can sustain a maximum tension of 800 lb before it fails. Determine the greatest vertical force F that can be applied to the boom. Also, what are the x, y, z components of reaction at the ball-and-socket joint A ?

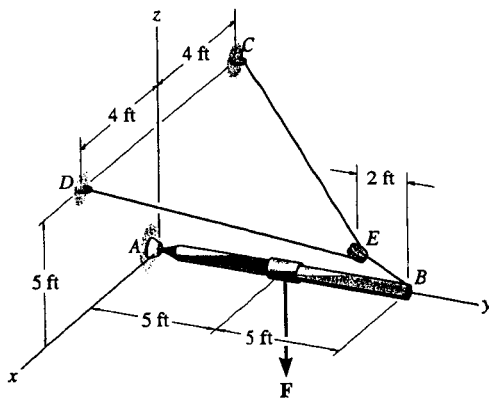

From FBD of pulley,

$$\Sigma F_z = 0; \quad 2(800) \cos 24.09^\circ - F_{BE} = 0$$

$$F_{BE} = 1460.59 \text{ lb}$$

From FBD of boom,

$$\Sigma M_x = 0; \quad \frac{5}{\sqrt{125}}(1460.59)(10) - F(5) = 0$$

$$F = 1306.39 \text{ lb} = 1.31 \text{ kip}$$

$$\Sigma F_x = 0; \quad A_x = 0$$

$$\Sigma F_y = 0; \quad A_y - \frac{10}{\sqrt{125}}(1460.59) = 0$$

$$A_y = 1306.39 \text{ lb} = 1.31 \text{ kip}$$

$$\Sigma F_z = 0; \quad A_z - 1306.39 + \frac{5}{\sqrt{125}}(1460.59) = 0$$

$$A_z = 653 \text{ lb}$$

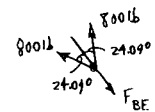

Ans

Ans

Ans

Ans

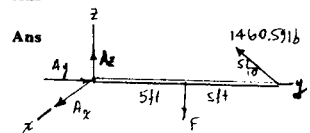

*5-72. Determine the force components acting on the ball-and-socket at A , the reaction at the roller B and the tension on the cord CD needed for equilibrium of the quarter circular plate.

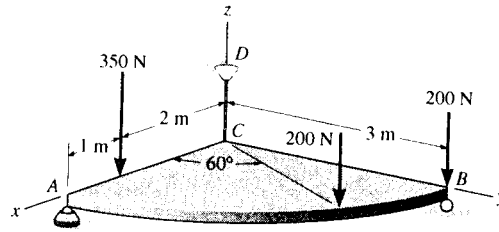

Equations of Equilibrium: The normal reaction N_B and A_z can be obtained directly by summing moments about the x and y axes respectively.

$$\Sigma M_x = 0; \quad N_B(3) - 200(3) - 200(3 \sin 60^\circ) = 0$$

$$N_B = 373.21 \text{ N} = 373 \text{ N}$$

Ans

$$\Sigma M_y = 0; \quad 350(2) + 200(3 \cos 60^\circ) - A_z(3) = 0$$

$$A_z = 333.33 \text{ N} = 333 \text{ N}$$

Ans

$$\Sigma F_z = 0; \quad T_{CD} + 373.21 + 333.33 - 350 - 200 - 200 = 0$$

$$T_{CD} = 43.5 \text{ N}$$

Ans

$$\Sigma F_x = 0; \quad A_x = 0$$

Ans

$$\Sigma F_y = 0; \quad A_y = 0$$

Ans

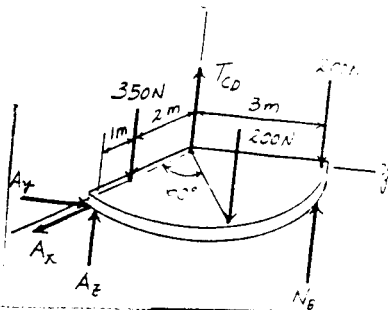

5-73. The windlass is subjected to a load of 150 lb. Determine the horizontal force P needed to hold the handle in the position shown, and the components of reaction at the ball-and-socket joint A and the smooth journal bearing B . The bearing at B is in proper alignment and exerts only force reactions on the windlass.

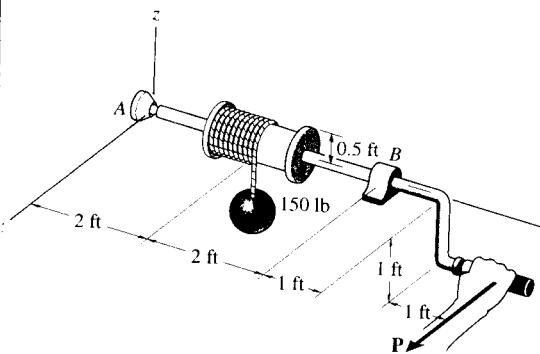

$$\Sigma M_y = 0; \quad (150)(0.5) - P(1) = 0$$

$$P = 75 \text{ lb} \quad \text{Ans}$$

$$\Sigma F_y = 0; \quad A_y = 0 \quad \text{Ans}$$

$$\Sigma M_x = 0; \quad -(150)(2) + B_z(4) = 0$$

$$B_z = 75 \text{ lb} \quad \text{Ans}$$

$$\Sigma F_z = 0; \quad A_z + 75 - 150 = 0$$

$$A_z = 75 \text{ lb}$$

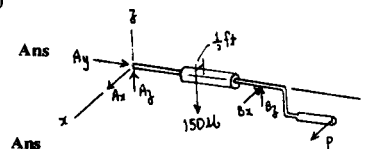

$$\Sigma M_z = 0; \quad B_x(4) - 75(6) = 0$$

$$B_x = 112.5 = 112 \text{ lb} \quad \text{Ans}$$

$$\Sigma F_x = 0; \quad A_x - 112.5 + 75 = 0$$

$$A_x = 37.5 \text{ lb} \quad \text{Ans}$$

5-74. The pole for a power line is subjected to the two cable forces of 60 lb, each force lying in a plane parallel to the x - y plane. If the tension in the guy wire AB is 80 lb, determine the x , y , z components of reaction at the fixed base of the pole, O .

Equations of Equilibrium:

$$\Sigma F_x = 0; \quad O_x + 60 \sin 45^\circ - 60 \sin 45^\circ = 0$$

$$O_x = 0$$

Ans

$$\Sigma F_y = 0; \quad O_y + 60 \cos 45^\circ + 60 \cos 45^\circ = 0$$

$$O_y = -84.9 \text{ lb}$$

Ans

$$\Sigma F_z = 0; \quad O_z - 80 = 0 \quad O_z = 80.0 \text{ lb}$$

Ans

$$\Sigma M_x = 0; \quad (M_0)_x + 80(3) - 2[60 \cos 45^\circ (14)] = 0$$

$$(M_0)_x = 948 \text{ lb} \cdot \text{ft}$$

Ans

$$\Sigma M_y = 0; \quad (M_0)_y + 60 \sin 45^\circ (14) - 60 \sin 45^\circ (14) = 0$$

$$(M_0)_y = 0$$

Ans

$$\Sigma M_z = 0; \quad (M_0)_z + 60 \sin 45^\circ (1) - 60 \sin 45^\circ (1) = 0$$

$$(M_0)_z = 0$$

Ans

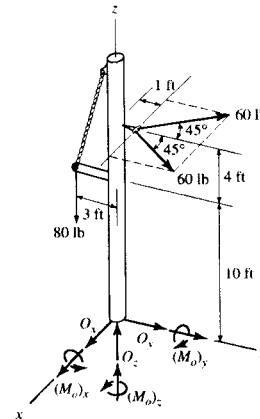
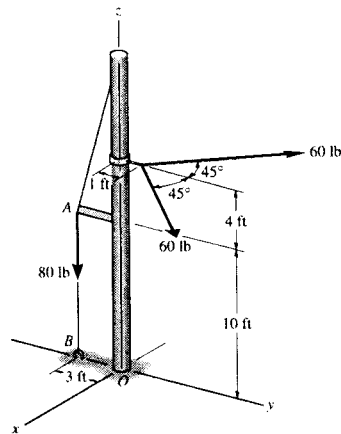

5-75. Member AB is supported by a cable BC and at A by a square rod which fits loosely through the square hole at the end joint of the member as shown. Determine the components of reaction at A and the tension in the cable needed to hold the 800-lb cylinder in equilibrium.

$$\mathbf{F}_{BC} = F_{BC} \left(\frac{3}{7}\mathbf{i} - \frac{6}{7}\mathbf{j} + \frac{2}{7}\mathbf{k} \right)$$

$$\Sigma F_x = 0; \quad F_{BC} \left(\frac{3}{7} \right) = 0$$

$$F_{BC} = 0$$

Ans

$$\Sigma F_y = 0; \quad A_y = 0$$

Ans

$$\Sigma F_z = 0; \quad A_z = 800 \text{ lb}$$

Ans

$$\Sigma M_x = 0; \quad (M_A)_x - 800(6) = 0$$

$$(M_A)_x = 4.80 \text{ kip} \cdot \text{ft}$$

Ans

$$\Sigma M_y = 0; \quad (M_A)_y = 0$$

Ans

$$\Sigma M_z = 0; \quad (M_A)_z = 0$$

Ans

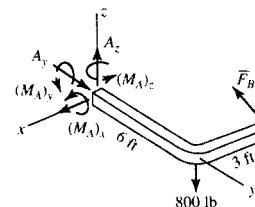
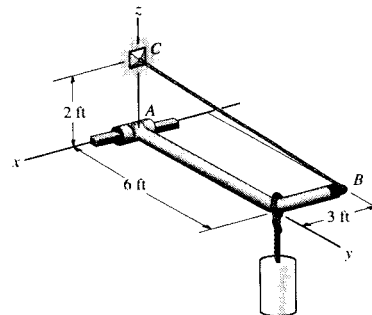

*5-76. The pipe assembly supports the vertical loads shown. Determine the components of reaction at the ball-and-socket joint A and the tension in the supporting cables BC and BD .

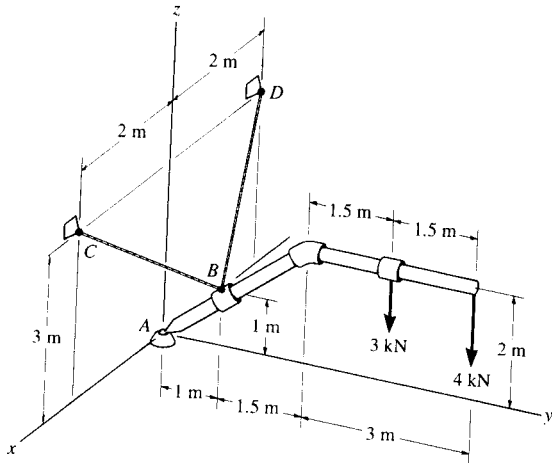

$$\mathbf{T}_{BD} = T_{BD} \left(\frac{-2}{3}\mathbf{i} - \frac{1}{3}\mathbf{j} + \frac{2}{3}\mathbf{k} \right)$$

$$\mathbf{T}_{BC} = T_{BC} \left(\frac{2}{3}\mathbf{i} - \frac{1}{3}\mathbf{j} + \frac{2}{3}\mathbf{k} \right)$$

$$\Sigma M_x = 0; \quad -3(4) - 4(5.5) + \frac{2}{3}T_{BD}(1) + \frac{2}{3}T_{BC}(1) + \frac{1}{3}T_{BD}(1) + \frac{1}{3}T_{BC}(1) = 0$$

$$T_{BD} + T_{BC} = 34$$

$$\Sigma M_y = 0; \quad \frac{2}{3}T_{BC}(1) - \frac{2}{3}T_{BD} = 0$$

$$T_{BC} = T_{BD}$$

$$T_{BC} = T_{BD} = 17 \text{ kN} \quad \text{Ans}$$

$$\Sigma F_y = 0; \quad A_y - 17\left(\frac{1}{3}\right) - 17\left(\frac{1}{3}\right) = 0$$

$$A_y = 11.3 \text{ kN} \quad \text{Ans}$$

$$\Sigma F_x = 0; \quad A_x = 0 \quad \text{Ans}$$

$$\Sigma F_z = 0; \quad A_z + 17\left(\frac{2}{3}\right) + 17\left(\frac{2}{3}\right) - 3 - 4 = 0$$

$$A_z = -15.7 \text{ kN} \quad \text{Ans}$$

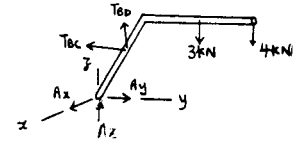

5-77. Both pulleys are fixed to the shaft and as the shaft turns with constant angular velocity, the power of pulley A is transmitted to pulley B . Determine the horizontal tension T in the belt on pulley B and the x , y , z components of reaction at the journal bearing C and thrust bearing D if $\theta = 0^\circ$. The bearings are in proper alignment and exert only force reactions on the shaft.

Equations of Equilibrium:

$$\Sigma M_x = 0; \quad 65(0.08) - 80(0.08) + T(0.15) - 50(0.15) = 0$$

$$T = 58.0 \text{ N} \quad \text{Ans}$$

$$\Sigma M_y = 0; \quad (65 + 80)(0.45) - C_z(0.75) = 0$$

$$C_z = 87.0 \text{ N} \quad \text{Ans}$$

$$\Sigma M_z = 0; \quad (50 + 58.0)(0.2) - C_y(0.75) = 0$$

$$C_y = 28.8 \text{ N} \quad \text{Ans}$$

$$\Sigma F_x = 0; \quad D_x = 0 \quad \text{Ans}$$

$$\Sigma F_y = 0; \quad D_y + 28.8 - 50 - 58.0 = 0$$

$$D_y = 79.2 \text{ N} \quad \text{Ans}$$

$$\Sigma F_z = 0; \quad D_z + 87.0 - 80 - 65 = 0$$

$$D_z = 58.0 \text{ N} \quad \text{Ans}$$

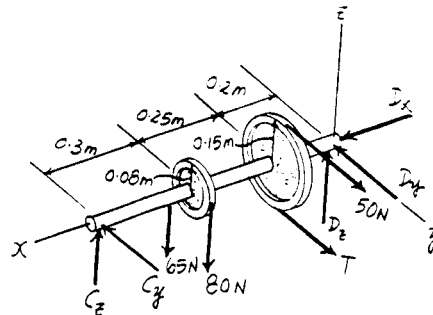
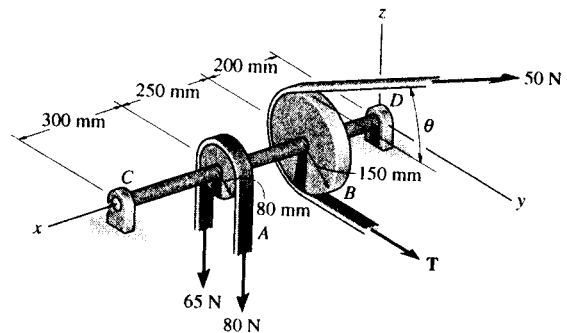

5-78. Both pulleys are fixed to the shaft and as the shaft turns with constant angular velocity, the power of pulley *A* is transmitted to pulley *B*. Determine the horizontal tension *T* in the belt on pulley *B* and the *x*, *y*, *z* components of reaction at the journal bearing *C* and thrust bearing *D* if $\theta = 45^\circ$. The bearings are in proper alignment and exert only force reactions on the shaft.

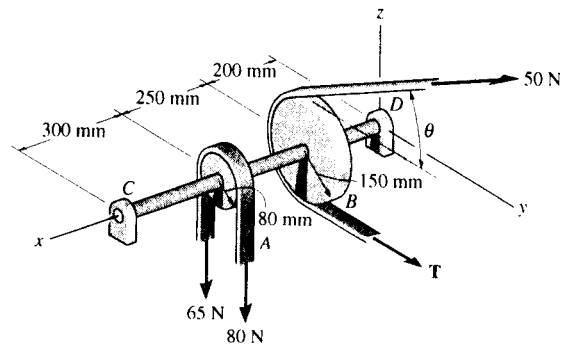

Equations of Equilibrium :

$$\Sigma M_x = 0; \quad 65(0.08) - 80(0.08) + T(0.15) - 50(0.15) = 0$$

$$T = 58.0 \text{ N} \quad \text{Ans}$$

$$\Sigma M_y = 0; \quad (65 + 80)(0.45) - 50 \sin 45^\circ (0.2) - C_z (0.75) = 0$$

$$C_z = 77.57 \text{ N} = 77.6 \text{ N} \quad \text{Ans}$$

$$\Sigma M_z = 0; \quad 58.0(0.2) + 50 \cos 45^\circ (0.2) - C_y (0.75) = 0$$

$$C_y = 24.89 \text{ N} = 24.9 \text{ N} \quad \text{Ans}$$

$$\Sigma F_x = 0; \quad D_x = 0 \quad \text{Ans}$$

$$\Sigma F_y = 0; \quad D_y + 24.89 - 50 \cos 45^\circ - 58.0 = 0$$

$$D_y = 68.5 \text{ N} \quad \text{Ans}$$

$$\Sigma F_z = 0; \quad D_z + 77.57 + 50 \sin 45^\circ - 80 - 65 = 0$$

$$D_z = 32.1 \text{ N} \quad \text{Ans}$$

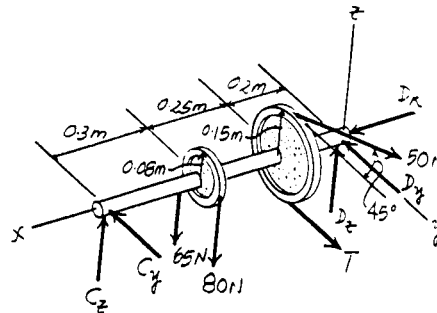

5-79. The bent rod is supported at A , B , and C by smooth journal bearings. Compute the x , y , z components of reaction at the bearings if the rod is subjected to forces $F_1 = 300$ lb and $F_2 = 250$ lb. F_1 lies in the y - z plane. The bearings are in proper alignment and exert only force reactions on the rod.

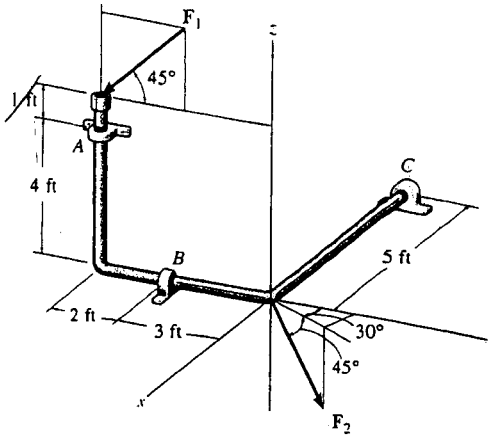

$$F_1 = (-300 \cos 45^\circ \mathbf{j} - 300 \sin 45^\circ \mathbf{k})$$

$$= \{-212.1 \mathbf{j} - 212.1 \mathbf{k}\} \text{ lb}$$

$$F_2 = (250 \cos 45^\circ \sin 30^\circ \mathbf{i} + 250 \cos 45^\circ \cos 30^\circ \mathbf{j} - 250 \sin 45^\circ \mathbf{k})$$

$$= \{88.39 \mathbf{i} + 153.1 \mathbf{j} - 176.8 \mathbf{k}\} \text{ lb}$$

$$\Sigma F_x = 0; \quad A_x + B_x + 88.39 = 0$$

$$\Sigma F_y = 0; \quad A_y + C_y - 212.1 + 153.1 = 0$$

$$\Sigma F_z = 0; \quad B_z + C_z - 212.1 - 176.8 = 0$$

$$\Sigma M_x = 0; \quad -B_z(3) - A_y(4) + 212.1(5) + 212.1(5) = 0$$

$$\Sigma M_y = 0; \quad C_z(5) + A_x(4) = 0$$

$$\Sigma M_z = 0; \quad A_x(5) + B_x(3) - C_y(5) = 0$$

$$A_x = 633 \text{ lb} \quad \text{Ans}$$

$$A_y = -141 \text{ lb} \quad \text{Ans}$$

$$B_x = -721 \text{ lb} \quad \text{Ans}$$

$$B_z = 895 \text{ lb} \quad \text{Ans}$$

$$C_y = 200 \text{ lb} \quad \text{Ans}$$

$$C_z = -506 \text{ lb} \quad \text{Ans}$$

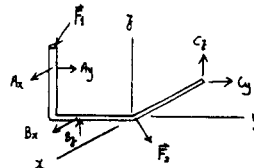

***5-80.** The bent rod is supported at A , B , and C by smooth journal bearings. Determine the magnitude of F_2 which will cause the reaction C_y at the bearing C to be equal to zero. The bearings are in proper alignment and exert only force reactions on the rod. Set $F_1 = 300$ lb.

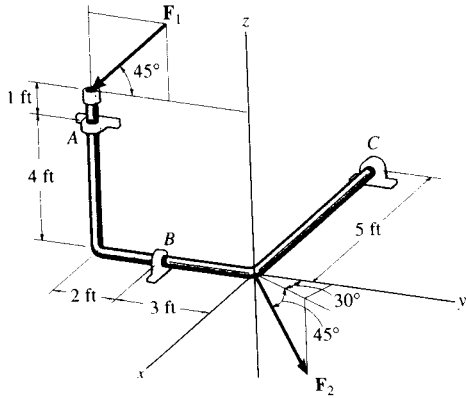

$$\begin{aligned} \mathbf{F}_1 &= (-300\cos 45^\circ\mathbf{j} - 300\sin 45^\circ\mathbf{k}) \\ &= \{-212.1\mathbf{j} - 212.1\mathbf{k}\} \text{ lb} \end{aligned}$$

$$\begin{aligned} \mathbf{F}_2 &= (F_2 \cos 45^\circ \sin 30^\circ\mathbf{i} + F_2 \cos 45^\circ \cos 30^\circ\mathbf{j} - F_2 \sin 45^\circ\mathbf{k}) \\ &= \{0.3536F_2\mathbf{i} + 0.6124F_2\mathbf{j} - 0.7071F_2\mathbf{k}\} \text{ lb} \end{aligned}$$

$$\Sigma F_x = 0; \quad A_x + B_x + 0.3536F_2 = 0$$

$$\Sigma F_y = 0; \quad A_y + 0.6124F_2 - 212.1 = 0$$

$$\Sigma F_z = 0; \quad B_z + C_z - 0.7071F_2 - 212.1 = 0$$

$$\Sigma M_x = 0; \quad -B_z(3) - A_y(4) + 212.1(5) + 212.1(5) = 0$$

$$\Sigma M_y = 0; \quad C_z(5) + A_z(4) = 0$$

$$\Sigma M_z = 0; \quad A_x(5) + B_x(3) = 0$$

$$A_x = 357 \text{ lb}$$

$$A_y = -200 \text{ lb}$$

$$B_x = -596 \text{ lb}$$

$$B_z = 974 \text{ lb}$$

$$C_z = -286 \text{ lb}$$

$$F_2 = 674 \text{ lb} \quad \text{Ans}$$

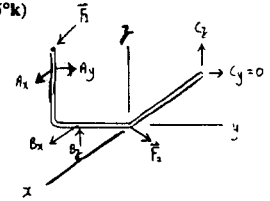

5-81. The silo has a weight of 3500 lb and a center of gravity at G . Determine the vertical component of force that each of the three struts at A , B , and C exerts on the silo if it is subjected to a resultant wind loading of 250 lb which acts in the direction shown.

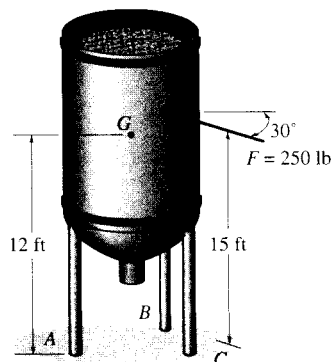
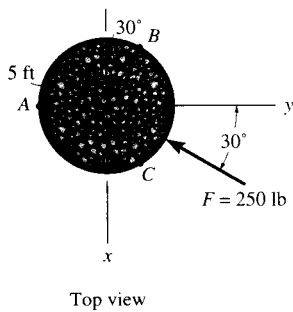

Set the coordinate-axes system at the base of the silo with the origin at point O .

$$\Sigma M_x = 0; \quad B_z(5 \sin 60^\circ) - C_z(5 \sin 60^\circ) - 250 \sin 30^\circ(15) = 0$$

$$4.330B_z - 4.330C_z - 1875 = 0 \quad [1]$$

$$\Sigma M_z = 0; \quad B_x(5 \cos 60^\circ) + C_x(5 \cos 60^\circ) - A_x(5) + 250 \cos 30^\circ(15) = 0$$

$$2.5B_x + 2.5C_x - 5A_x + 3247.6 = 0 \quad [2]$$

$$\Sigma F_z = 0; \quad A_z + B_z + C_z - 3500 = 0 \quad [3]$$

Solving Eqs. [1], [2] and [3] yields :

$$B_z = 1167 \text{ lb} \quad C_z = 734 \text{ lb} \quad A_z = 1600 \text{ lb} \quad \text{Ans}$$

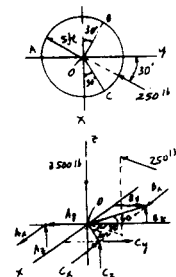

5-82. Determine the tensions in the cables and the components of reaction acting on the smooth collar at A necessary to hold the 50-lb sign in equilibrium. The center of gravity for the sign is at G.

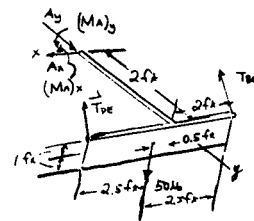
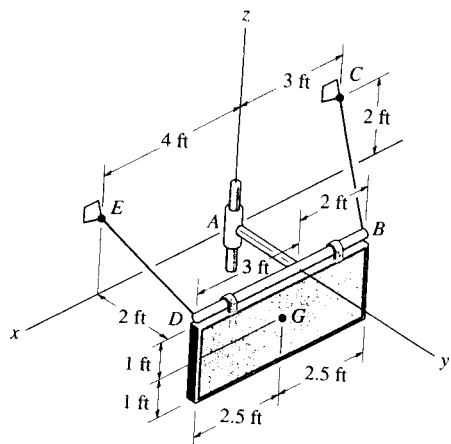

$$T_{DE} = T_{DE} \left(\frac{1}{3}i - \frac{2}{3}j + \frac{2}{3}k \right)$$

$$T_{BC} = T_{BC} \left(-\frac{1}{3}i - \frac{2}{3}j + \frac{2}{3}k \right)$$

$$\Sigma F_x = 0; \quad \frac{1}{3}T_{DE} - \frac{1}{3}T_{BC} + A_x = 0$$

$$\Sigma F_y = 0; \quad \frac{2}{3}T_{DE} + \frac{2}{3}T_{BC} - 50 = 0$$

$$\Sigma F_z = 0; \quad -\frac{2}{3}T_{DE} - \frac{2}{3}T_{BC} + A_y = 0$$

$$\Sigma M_x = 0; \quad (M_A)_x + \frac{2}{3}T_{DE}(2) + \frac{2}{3}T_{BC}(2) - 50(2) = 0$$

$$\Sigma M_y = 0; \quad (M_A)_y - \frac{2}{3}T_{DE}(3) + \frac{2}{3}T_{BC}(2) + 50(0.5) = 0$$

$$\Sigma M_z = 0; \quad -\frac{1}{3}T_{DE}(2) - \frac{2}{3}T_{DE}(3) + \frac{1}{3}T_{BC}(2) + \frac{2}{3}T_{BC}(2) = 0$$

Solving;

$$T_{DE} = 32.1429 = 32.1 \text{ lb} \quad \text{Ans}$$

$$T_{BC} = 42.8571 = 42.9 \text{ lb} \quad \text{Ans}$$

$$A_x = 3.5714 = 3.57 \text{ lb} \quad \text{Ans}$$

$$A_y = 50 \text{ lb} \quad \text{Ans}$$

$$(M_A)_x = 0 \quad \text{Ans}$$

$$(M_A)_y = -17.8571 = -17.9 \text{ lb}\cdot\text{ft} \quad \text{Ans}$$

5-83. The boom is supported by a ball-and-socket joint at A and a guy wire at B. If the 5-kN loads lie in a plane which is parallel to the x-y plane, determine the x, y, z components of reaction at A and the tension in the cable at B.

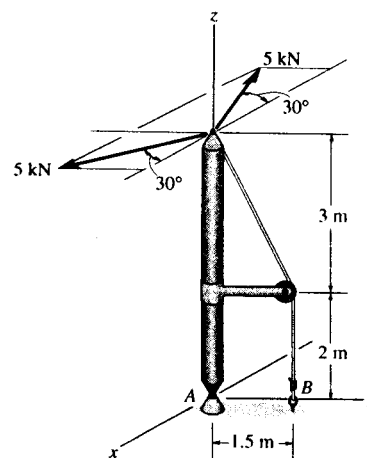

Equations of Equilibrium :

$$\Sigma M_x = 0; \quad 2[5 \sin 30^\circ (5)] - T_B (1.5) = 0$$

$$T_B = 16.67 \text{ kN} = 16.7 \text{ kN}$$

$$\Sigma M_y = 0; \quad 5 \cos 30^\circ (5) - 5 \cos 30^\circ (5) = 0 \text{ (Satisfied!)}$$

$$\Sigma F_x = 0; \quad A_x + 5 \cos 30^\circ - 5 \cos 30^\circ = 0$$

$$A_x = 0$$

$$\Sigma F_y = 0; \quad A_y - 2(5 \sin 30^\circ) = 0$$

$$A_y = 5.00 \text{ kN}$$

$$\Sigma F_z = 0; \quad A_z - 16.67 = 0 \quad A_z = 16.7 \text{ kN}$$

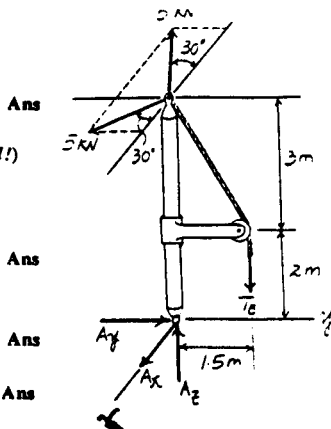

*5-84. The boom AC is supported at A by a ball-and-socket joint and by two cables BDC and CE . Cable BDC is continuous and passes over a pulley at D . Calculate the tension in the cables and the x, y, z components of reaction at A if a crate has a weight of 80 lb.

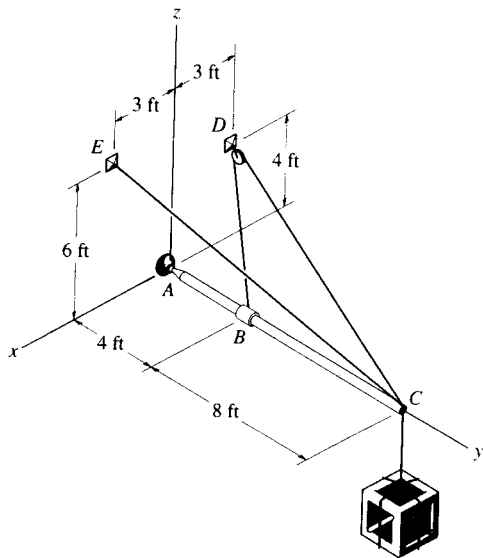

$$\mathbf{F}_{CE} = F_{CE} \frac{(3\mathbf{i} - 12\mathbf{j} + 6\mathbf{k})}{\sqrt{3^2 + (-12)^2 + 6^2}}$$

$$= \{ 0.2182F_{CE}\mathbf{i} - 0.8729F_{CE}\mathbf{j} + 0.4364F_{CE}\mathbf{k} \} \text{ lb}$$

$$\mathbf{F}_{CD} = F_{BDC} \frac{(-3\mathbf{i} - 12\mathbf{j} + 4\mathbf{k})}{\sqrt{(-3)^2 + (-12)^2 + 4^2}}$$

$$= \{ -0.2308F_{BDC}\mathbf{i} - 0.9231F_{BDC}\mathbf{j} + 0.3077F_{BDC}\mathbf{k} \} \text{ lb}$$

$$\mathbf{F}_{BD} = F_{BDC} \frac{(-3\mathbf{i} - 4\mathbf{j} + 4\mathbf{k})}{\sqrt{(-3)^2 + (-4)^2 + 4^2}}$$

$$= F_{BDC}(-0.4685\mathbf{i} - 0.6247\mathbf{j} + 0.6247\mathbf{k})$$

$$\Sigma M_x = 0; \quad F_{BDC}(0.6247)(4) + 0.4364F_{CE}(12) + 0.3077F_{BDC}(12) - 80(12) = 0$$

$$\Sigma M_y = 0; \quad 0.4685F_{BDC}(4) + 0.2308F_{BDC}(12) - 0.2182F_{CE}(12) = 0$$

$$F_{BDC} = 62.02 = 62.0 \text{ lb} \quad \text{Ans}$$

$$F_{CE} = 109.99 = 110 \text{ lb} \quad \text{Ans}$$

$$\Sigma F_x = 0; \quad A_x + 0.2182(109.99) - 0.2308(62.02) - 0.4685(62.02) = 0$$

$$A_x = 19.4 \text{ lb} \quad \text{Ans}$$

$$\Sigma F_y = 0; \quad A_y - 0.8729(109.99) - 0.9231(62.02) - 0.6247(62.02) = 0$$

$$A_y = 192 \text{ lb} \quad \text{Ans}$$

$$\Sigma F_z = 0; \quad A_z + 0.4364(109.99) + 0.3077(62.02) + 0.6247(62.02) - 80 = 0$$

$$A_z = -25.8 \text{ lb} \quad \text{Ans}$$

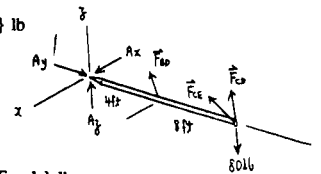

5-85. Rod AB is supported by a ball-and-socket joint at A and a cable at B . Determine the x, y, z components of reaction at these supports if the rod is subjected to a 50-lb vertical force as shown.

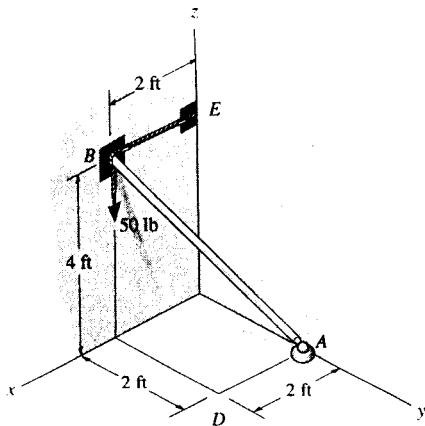

$$\Sigma F_x = 0; \quad -T_B + A_x = 0$$

$$\Sigma F_y = 0; \quad A_y + B_y = 0$$

$$\Sigma F_z = 0; \quad -50 + A_z = 0$$

$$\Sigma M_{Ax} = 0; \quad 50(2) - B_y(4) = 0$$

$$\Sigma M_{Ay} = 0; \quad 50(2) - T_B(4) = 0$$

$$\Sigma M_{Az} = 0; \quad B_y(2) - T_B(2) = 0$$

Solving,

$$T_B = 25 \text{ lb} \quad \text{Ans}$$

$$A_x = 25 \text{ lb} \quad \text{Ans}$$

$$A_y = -25 \text{ lb} \quad \text{Ans}$$

$$A_z = 50 \text{ lb} \quad \text{Ans}$$

$$B_y = 25 \text{ lb} \quad \text{Ans}$$

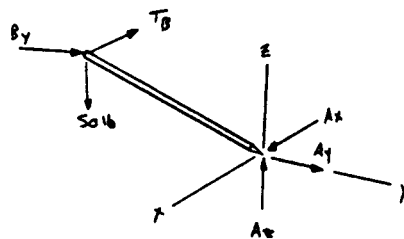

5-86. A vertical force of 50 lb acts on the crankshaft. Determine the horizontal equilibrium force P that must be applied to the handle and the x, y, z components of reaction at the journal bearing A and thrust bearing B . The bearings are properly aligned and exert only force reactions on the shaft.

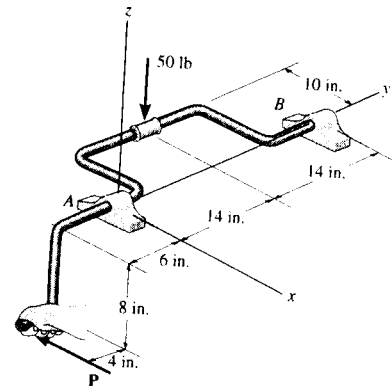

Equations of Equilibrium :

$$\Sigma M_x = 0; \quad B_z(28) - 50(14) = 0 \quad B_z = 25.0 \text{ lb} \quad \text{Ans}$$

$$\Sigma M_y = 0; \quad P(8) - 50(10) = 0 \quad P = 62.5 \text{ lb} \quad \text{Ans}$$

$$\Sigma M_z = 0; \quad B_x(28) - 62.5(10) = 0 \\ B_x = 22.32 \text{ lb} = 22.3 \text{ lb} \quad \text{Ans}$$

$$\Sigma F_x = 0; \quad 62.5 + 22.32 - A_x = 0 \quad A_x = 84.8 \text{ lb} \quad \text{Ans}$$

$$\Sigma F_y = 0; \quad B_y = 0 \quad \text{Ans}$$

$$\Sigma F_z = 0; \quad A_z + 25.0 - 50 = 0 \quad A_z = 25.0 \text{ lb} \quad \text{Ans}$$

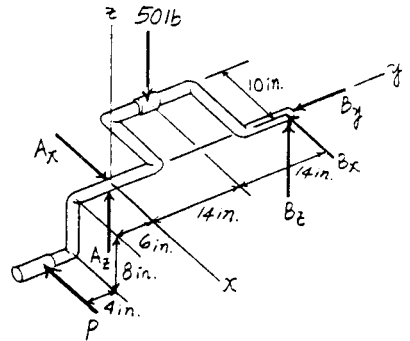

5-87. The platform has a mass of 2 Mg and center of mass located at G . If it is lifted using the three cables, determine the force in each of these cables. Solve for each force by using a single moment equation of equilibrium.

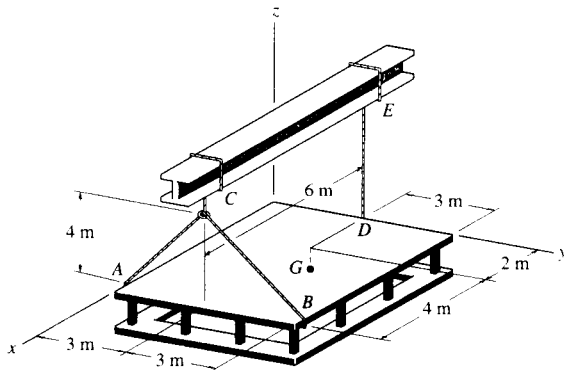

$$\Sigma F_y = 0; \quad \frac{3}{4}F_{AC} - \frac{3}{4}F_{BC} = 0; \quad F_{AC} = F_{BC}$$

$$\Sigma M_y = 0; \quad 3(9.81)(2) - \frac{4}{5}F_{AC}(6) - \frac{4}{5}F_{BC}(6) = 0$$

$$F_{AC} = F_{BC} = 6.131 = 6.13 \text{ kN} \quad \text{Ans}$$

$$\Sigma M_x = 0; \quad \frac{4}{5}(6.131)(6) - 3(9.81)(3) + F_{DE}(3) = 0$$

$$F_{DE} = 19.62 = 19.6 \text{ kN} \quad \text{Ans}$$

$$\Sigma F_z = 0; \quad \frac{4}{5}(6.131) + \frac{4}{5}(6.131) + 19.62 - 3(9.81) = 0 \quad \text{Check !}$$

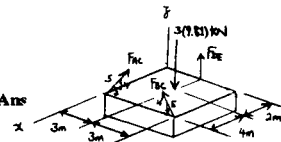

*5-88. The platform has a mass of 2 Mg and center of mass located at G . If it is lifted using the three cables, determine the force in each of the cables. Solve for each force by using a single moment equation of equilibrium.

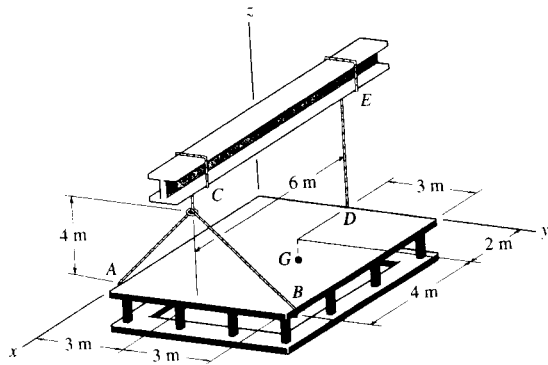

$$\Sigma M_y = 0; \quad F_{DE}(6) - 2(9.81)(4) = 0$$

$$F_{DE} = 13.1 \text{ kN} \quad \text{Ans}$$

$$\Sigma M_{aa} = 0; \quad \mathbf{u}_{aa} \cdot (\mathbf{r}_{AB} \times \mathbf{F}_{BC}) + \mathbf{u}_{aa} \cdot (\mathbf{r}_{AG} \times \mathbf{W}) = 0$$

$$\begin{vmatrix} -0.8944 & 0.4472 & 0 \\ 0 & 6 & 0 \\ 0 & -0.6F_{BC} & 0.8F_{BC} \end{vmatrix} + \begin{vmatrix} -0.8944 & 0.4472 & 0 \\ -4 & 3 & 0 \\ 0 & 0 & -19.62 \end{vmatrix} = 0$$

$$-0.8944(6)(0.8F_{BC}) - 0.8944(3)(-19.62) - 0.4472(-4)(-19.62) = 0$$

$$F_{BC} = 4.09 \text{ kN} \quad \text{Ans}$$

$$\Sigma M_{bb} = 0; \quad \mathbf{u}_{bb} \cdot (\mathbf{r}_{BA} \times \mathbf{F}_{AC}) + \mathbf{u}_{bb} \cdot (\mathbf{r}_{BG} \times \mathbf{W}) = 0$$

$$\begin{vmatrix} -0.8944 & -0.4472 & 0 \\ 0 & -6 & 0 \\ 0 & 0.6F_{AC} & 0.8F_{AC} \end{vmatrix} + \begin{vmatrix} -0.8944 & -0.4472 & 0 \\ -4 & -3 & 0 \\ 0 & 0 & -19.62 \end{vmatrix} = 0$$

$$-0.8944(-6)(0.8F_{AC}) - 0.8944(-3)(-19.62) + (0.4472)(-4)(-19.62) = 0$$

$$F_{AC} = 4.09 \text{ kN} \quad \text{Ans}$$

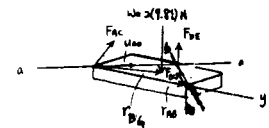

5-89. The cables exert the forces shown on the pole. Assuming the pole is supported by a ball-and-socket joint at its base, determine the components of reaction at A. The forces of 140 lb and 75 lb lie in a horizontal plane.

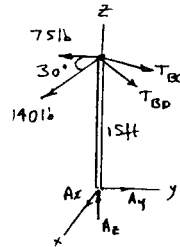
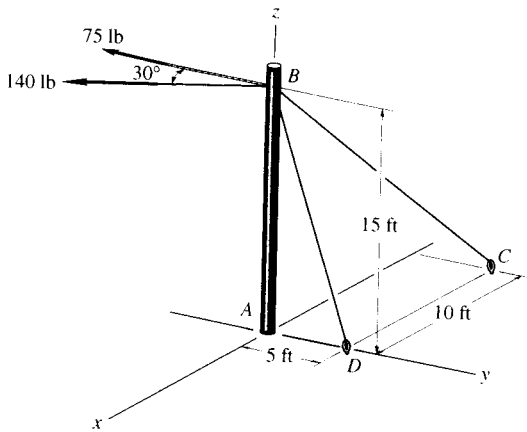

$$T_{BD} = \frac{1}{\sqrt{10}} T_{BD} \mathbf{j} - \frac{3}{\sqrt{10}} T_{BD} \mathbf{k}$$

$$T_{BC} = \frac{-10}{\sqrt{350}} T_{BC} \mathbf{i} + \frac{5}{\sqrt{350}} T_{BC} \mathbf{j} - \frac{15}{\sqrt{350}} T_{BC} \mathbf{k}$$

$$\Sigma M_x = 0; \quad (140 \cos 30^\circ + 75)(15) - \frac{5}{\sqrt{350}} T_{BC}(15) - \frac{1}{\sqrt{10}} T_{BD}(15) = 0$$

$$\Sigma M_y = 0; \quad 140 \sin 30^\circ (15) - \frac{10}{\sqrt{350}} T_{BC}(15) = 0$$

$$\Sigma F_x = 0; \quad A_x + 140 \sin 30^\circ - \frac{10}{\sqrt{350}} T_{BC} = 0$$

$$\Sigma F_y = 0; \quad A_y - 140 \cos 30^\circ - 75 + \frac{1}{\sqrt{10}} T_{BD} + \frac{5}{\sqrt{350}} T_{BC} = 0$$

$$\Sigma F_z = 0; \quad A_z - \frac{3}{\sqrt{10}} T_{BD} - \frac{15}{\sqrt{350}} T_{BC} = 0$$

$$T_{BC} = 130.96 = 131 \text{ lb} \quad \text{Ans}$$

$$T_{BD} = 510 \text{ lb} \quad \text{Ans}$$

$$A_x = 0 \quad \text{Ans}$$

$$A_y = 0 \quad \text{Ans}$$

$$A_z = 589 \text{ lb} \quad \text{Ans}$$

Also, note that BA is a two-force member, so that $A_x = A_y = 0$.

5-90. The pole is subjected to the two forces shown. Determine the components of reaction at A assuming it to be a ball-and-socket joint. Also, compute the tension in each of the guy wires, BC and ED .

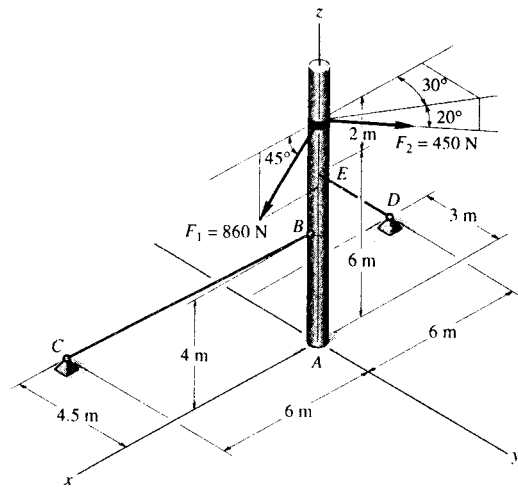

Force Vector and Position Vectors :

$$F_A = A_x i + A_y j + A_z k$$

$$F_1 = 860 \{ \cos 45^\circ i - \sin 45^\circ k \} \text{ N} = \{ 608.11i - 608.11k \} \text{ N}$$

$$F_2 = 450 \{ -\cos 20^\circ \cos 30^\circ i + \cos 20^\circ \sin 30^\circ k - \sin 20^\circ j \} \text{ N} \\ = \{ -366.21i + 211.43j - 153.91k \} \text{ N}$$

$$F_{ED} = F_{ED} \left[\frac{(-6-0)i + (-3-0)j + (0-6)k}{\sqrt{(-6-0)^2 + (-3-0)^2 + (0-6)^2}} \right] \\ = -\frac{2}{3}F_{ED}i - \frac{1}{3}F_{ED}j - \frac{2}{3}F_{ED}k$$

$$F_{BC} = F_{BC} \left[\frac{(6-0)i + (-4.5-0)j + (0-4)k}{\sqrt{(6-0)^2 + (-4.5-0)^2 + (0-4)^2}} \right] \\ = \frac{12}{17}F_{BC}i - \frac{9}{17}F_{BC}j - \frac{8}{17}F_{BC}k$$

$$r_1 = \{ 4k \} \text{ m} \quad r_2 = \{ 8k \} \text{ m} \quad r_3 = \{ 6k \} \text{ m}$$

Equations of Equilibrium : Force equilibrium requires

$$\Sigma F = 0; \quad F_A + F_1 + F_2 + F_{ED} + F_{BC} = 0$$

$$\left(A_x + 608.11 - 366.21 - \frac{2}{3}F_{ED} + \frac{12}{17}F_{BC} \right) i \\ + \left(A_y + 211.43 - \frac{1}{3}F_{ED} - \frac{9}{17}F_{BC} \right) j \\ + \left(A_z - 608.11 - 153.91 - \frac{2}{3}F_{ED} - \frac{8}{17}F_{BC} \right) k = 0$$

Equating i, j and k components, we have

$$\Sigma F_x = 0; \quad A_x + 608.11 - 366.21 - \frac{2}{3}F_{ED} + \frac{12}{17}F_{BC} = 0 \quad [1]$$

$$\Sigma F_y = 0; \quad A_y + 211.43 - \frac{1}{3}F_{ED} - \frac{9}{17}F_{BC} = 0 \quad [2]$$

$$\Sigma F_z = 0; \quad A_z - 608.11 - 153.91 - \frac{2}{3}F_{ED} - \frac{8}{17}F_{BC} = 0 \quad [3]$$

Moment equilibrium requires

$$\Sigma M_A = 0; \quad r_1 \times F_{BC} + r_2 \times (F_1 + F_2) + r_3 \times F_{ED} = 0$$

$$4k \times \left(\frac{12}{17}F_{BC}i - \frac{9}{17}F_{BC}j - \frac{8}{17}F_{BC}k \right) \\ + 8k \times (241.90i + 211.43j - 762.02k) \\ + 6k \times \left(-\frac{2}{3}F_{ED}i - \frac{1}{3}F_{ED}j - \frac{2}{3}F_{ED}k \right) = 0$$

Equating i, j and k components, we have

$$\Sigma M_x = 0; \quad \frac{36}{17}F_{BC} + 2F_{ED} - 1691.45 = 0 \quad [4]$$

$$\Sigma M_y = 0; \quad \frac{48}{17}F_{BC} - 4F_{ED} + 1935.22 = 0 \quad [5]$$

Solving Eqs. [4] and [5] yields

$$F_{BC} = 205.09 \text{ N} = 205 \text{ N} \quad F_{ED} = 628.57 \text{ N} = 629 \text{ N} \quad \text{Ans}$$

Substituting the results into Eqs. [1], [2] and [3] yields

$$A_x = 32.4 \text{ N} \quad A_y = 107 \text{ N} \quad A_z = 1277.58 \text{ N} = 1.28 \text{ kN} \quad \text{Ans}$$

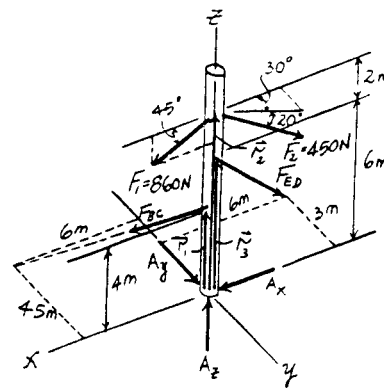

***5-91.** The shaft assembly is supported by two smooth journal bearings *A* and *B* and a short link *DC*. If a couple moment is applied to the shaft as shown, determine the components of force reaction at the bearings and the force in the link. The link lies in a plane parallel to the *y-z* plane and the bearings are properly aligned on the shaft.

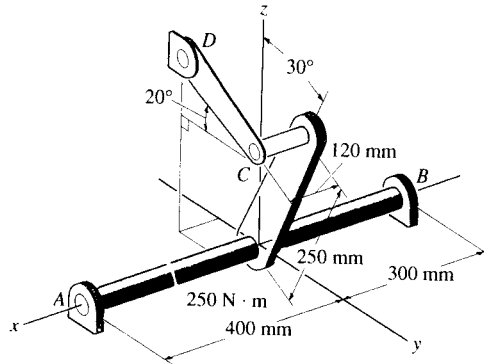

$$\Sigma M_x = 0; \quad -250 + F_{CD} \cos 20^\circ (0.25 \cos 30^\circ) + F_{CD} \sin 20^\circ (0.25 \sin 30^\circ) = 0$$

$$F_{CD} = 1015.43 \text{ N} = 1.02 \text{ kN} \quad \text{Ans}$$

$$\Sigma (M_B)_y = 0; \quad -A_z (0.7) - 1015.43 \sin 20^\circ (0.42) = 0$$

$$A_z = -208.38 = -208 \text{ N} \quad \text{Ans}$$

$$\Sigma F_z = 0; \quad -208.38 + 1015.43 \sin 20^\circ + B_z = 0$$

$$B_z = -139 \text{ N} \quad \text{Ans}$$

$$\Sigma (M_B)_x = 0; \quad A_y (0.7) - 1015.43 \cos 20^\circ (0.42) = 0$$

$$A_y = 572.51 = 573 \text{ N} \quad \text{Ans}$$

$$\Sigma F_y = 0; \quad 572.51 - 1015.43 \cos 20^\circ + B_y = 0$$

$$B_y = 382 \text{ N} \quad \text{Ans}$$

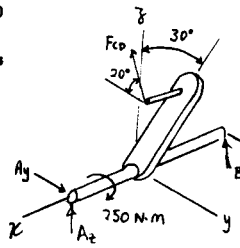

5-92. Determine the horizontal and vertical components of reaction at the pin A and the reaction at the roller B required to support the truss. Set $F = 600$ N.

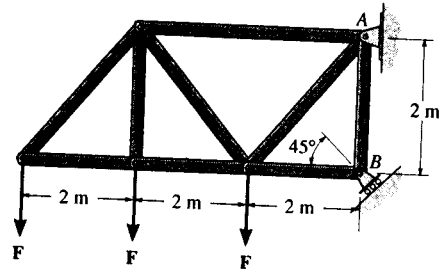

Equations of Equilibrium: The normal reaction N_B can be obtained directly by summing moments about point A .

$$\begin{aligned} \curvearrowright + \Sigma M_A = 0; & \quad 600(6) + 600(4) + 600(2) - N_B \cos 45^\circ(2) = 0 \\ & \quad N_B = 5091.17 \text{ N} = 5.09 \text{ kN} \end{aligned} \quad \text{Ans}$$

$$\begin{aligned} \rightarrow \Sigma F_x = 0; & \quad A_x - 5091.17 \cos 45^\circ = 0 \\ & \quad A_x = 3600 \text{ N} = 3.60 \text{ kN} \end{aligned} \quad \text{Ans}$$

$$\begin{aligned} + \uparrow \Sigma F_y = 0; & \quad 5091.17 \sin 45^\circ - 3(600) - A_y = 0 \\ & \quad A_y = 1800 \text{ N} = 1.80 \text{ kN} \end{aligned} \quad \text{Ans}$$

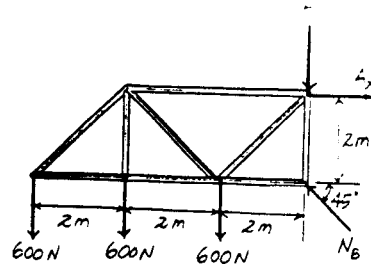

5-93. If the roller at B can sustain a maximum load of 3 kN, determine the largest magnitude of each of the three forces F that can be supported by the truss.

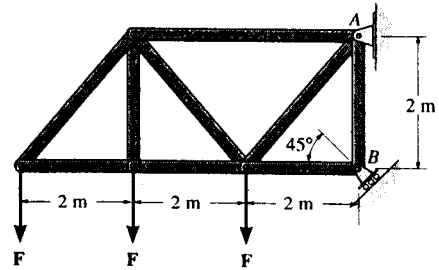

Equations of Equilibrium: The unknowns A_x and A_y can be eliminated by summing moments about point A .

$$\begin{aligned} \curvearrowright + \Sigma M_A = 0; & \quad F(6) + F(4) + F(2) - 3 \cos 45^\circ(2) = 0 \\ & \quad F = 0.3536 \text{ kN} = 354 \text{ N} \end{aligned} \quad \text{Ans}$$

5-94. Determine the normal reaction at the roller A and horizontal and vertical components at pin B for equilibrium of the member.

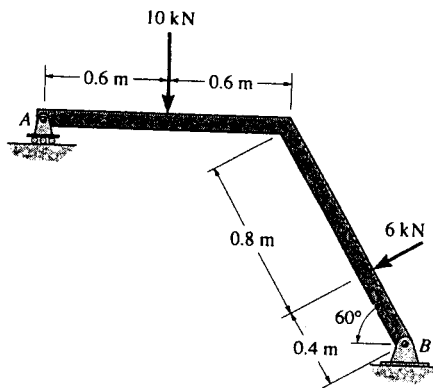

Equations of Equilibrium : The normal reaction N_A can be obtained directly by summing moments about point B .

$$\begin{aligned} \curvearrowright + \Sigma M_B = 0; & \quad 10(0.6 + 1.2 \cos 60^\circ) + 6(0.4) \\ & \quad - N_A(1.2 + 1.2 \cos 60^\circ) = 0 \end{aligned}$$

$$N_A = 8.00 \text{ kN}$$

Ans

$$\rightarrow \Sigma F_x = 0; \quad B_x - 6 \cos 30^\circ = 0 \quad B_x = 5.20 \text{ kN}$$

Ans

$$\begin{aligned} + \uparrow \Sigma F_y = 0; & \quad B_y + 8.00 - 6 \sin 30^\circ - 10 = 0 \\ & \quad B_y = 5.00 \text{ kN} \end{aligned}$$

Ans

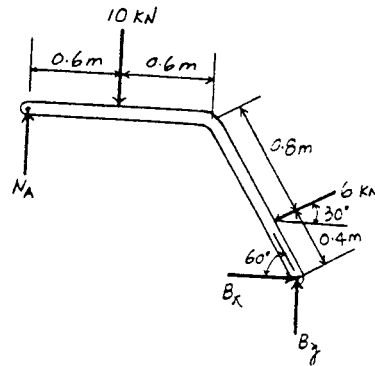

*5-95. The symmetrical shelf is subjected to a uniform load of 4 kPa. Support is provided by a bolt (or pin) located at each end A and A' and by the symmetrical brace arms, which bear against the smooth wall on both sides at B and B' . Determine the force resisted by each bolt at the wall and the normal force at B for equilibrium.

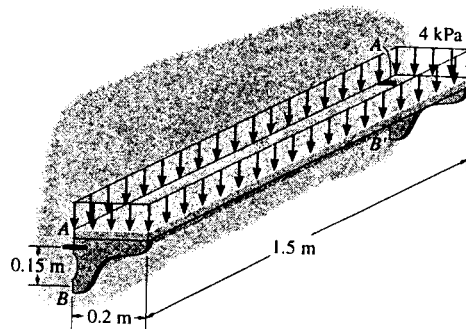

Equations of Equilibrium : Each shelf's post at its end supports half of the applied load, i.e., $4000(0.2)(0.75) = 600 \text{ N}$. The normal reaction N_B can be obtained directly by summing moments about point A .

$$\curvearrowright + \Sigma M_A = 0; \quad N_B(0.15) - 600(0.1) = 0 \quad N_B = 400 \text{ N} \quad \text{Ans}$$

$$\rightarrow \Sigma F_x = 0; \quad 400 - A_x = 0 \quad A_x = 400 \text{ N}$$

$$+ \uparrow \Sigma F_y = 0; \quad A_y - 600 = 0 \quad A_y = 600 \text{ N}$$

The force resisted by the bolt at A is

$$F_A = \sqrt{A_x^2 + A_y^2} = \sqrt{400^2 + 600^2} = 721 \text{ N}$$

Ans

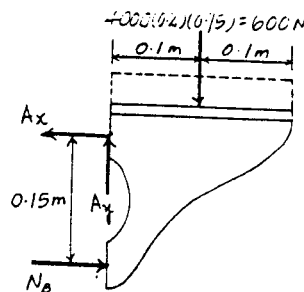

5-96. Determine the x and z components of reaction at the journal bearing A and the tension in cords BC and BD necessary for equilibrium of the rod.

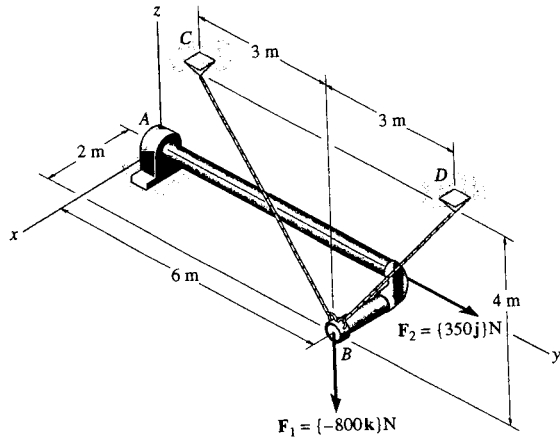

$$\mathbf{F}_1 = \{-800\mathbf{k}\} \text{ N}$$

$$\mathbf{F}_2 = \{350\mathbf{j}\} \text{ N}$$

$$\begin{aligned} \mathbf{F}_{BC} &= F_{BC} \frac{(-3\mathbf{j} + 4\mathbf{k})}{5} \\ &= \{-0.6F_{BC}\mathbf{j} + 0.8F_{BC}\mathbf{k}\} \text{ N} \end{aligned}$$

$$\begin{aligned} \mathbf{F}_{BD} &= F_{BD} \frac{(3\mathbf{j} + 4\mathbf{k})}{5} \\ &= \{0.6F_{BD}\mathbf{j} + 0.8F_{BD}\mathbf{k}\} \text{ N} \end{aligned}$$

$$\Sigma F_x = 0; \quad A_x = 0 \quad \text{Ans}$$

$$\Sigma F_y = 0; \quad 350 - 0.6F_{BC} + 0.6F_{BD} = 0$$

$$\Sigma F_z = 0; \quad A_z - 800 + 0.8F_{BC} + 0.8F_{BD} = 0$$

$$\Sigma M_x = 0; \quad M_{Ax} + 0.8F_{BD}(6) + 0.8F_{BC}(6) - 800(6) = 0$$

$$\Sigma M_y = 0; \quad 800(2) - 0.8F_{BC}(2) - 0.8F_{BD}(2) = 0$$

$$\Sigma M_z = 0; \quad M_{Az} - 0.6F_{BC}(2) + 0.6F_{BD}(2) = 0$$

$$F_{BD} = 208 \text{ N} \quad \text{Ans}$$

$$F_{BC} = 792 \text{ N} \quad \text{Ans}$$

$$A_z = 0 \quad \text{Ans}$$

$$M_{Ax} = 0 \quad \text{Ans}$$

$$M_{Az} = 700 \text{ N}\cdot\text{m} \quad \text{Ans}$$

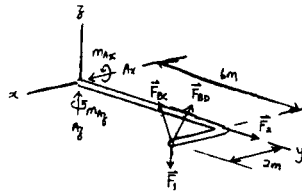

5-97. Determine the reactions at the supports A and B for equilibrium of the beam.

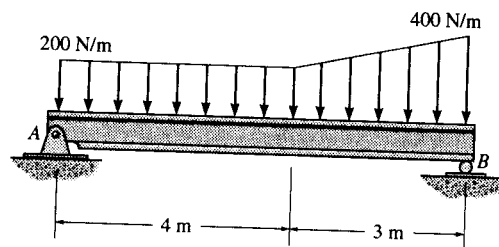

Equations of Equilibrium: The normal reaction N_B can be obtained directly by summing moments about point A .

$$+\Sigma M_A = 0; \quad N_B(7) - 1400(3.5) - 300(6) = 0$$

$$N_B = 957.14 \text{ N} = 957 \text{ N} \quad \text{Ans}$$

$$A_g - 1400 - 300 + 957 = 0 \quad A_g = 743 \text{ N}$$

$$+\Sigma F_x = 0; \quad A_x = 0 \quad \text{Ans}$$

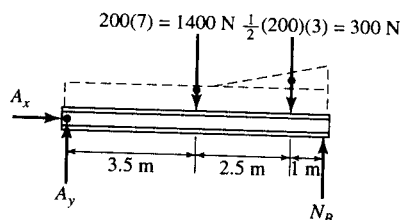

5-98. Determine the x , y , z components of reaction at the ball supports B and C and the ball-and-socket A (not shown) for the uniformly loaded plate.

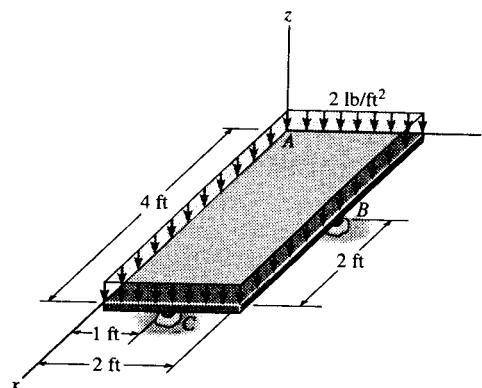

$$W = (4 \text{ ft})(2 \text{ ft})(2 \text{ lb/ft}^2) = 16 \text{ lb}$$

$$\Sigma F_x = 0; \quad A_x = 0 \quad \text{Ans}$$

$$\Sigma F_y = 0; \quad A_y = 0 \quad \text{Ans}$$

$$\Sigma F_z = 0; \quad A_z + B_z + C_z - 16 = 0 \quad (1)$$

$$\Sigma M_x = 0; \quad 2B_z - 16(1) + C_z(1) = 0 \quad (2)$$

$$\Sigma M_y = 0; \quad -B_z(2) + 16(2) - C_z(4) = 0 \quad (3)$$

Solving Eqs. (1)–(3):

$$A_z = B_z = C_z = 5.33 \text{ lb} \quad \text{Ans}$$

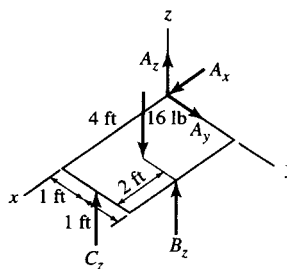

*5-99. Determine the x , y , z components of reaction at the fixed wall A . The 150-N force is parallel to the z axis and the 200-N force is parallel to the y axis.

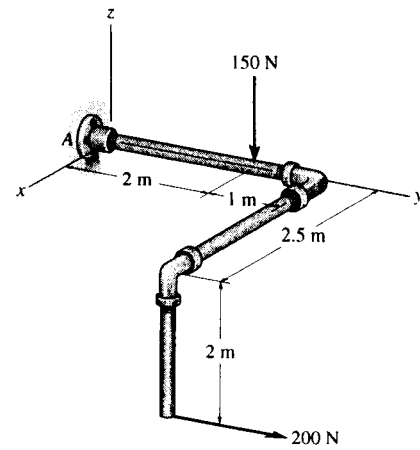

Equations of Equilibrium :

$$\Sigma F_x = 0; \quad A_x = 0 \quad \text{Ans}$$

$$\Sigma F_y = 0; \quad A_y + 200 = 0 \quad A_y = -200 \text{ N} \quad \text{Ans}$$

$$\Sigma F_z = 0; \quad A_z - 150 = 0 \quad A_z = 150 \text{ N} \quad \text{Ans}$$

$$\Sigma M_x = 0; \quad (M_A)_x + 200(2) - 150(2) = 0 \\ (M_A)_x = -100 \text{ N} \cdot \text{m} \quad \text{Ans}$$

$$\Sigma M_y = 0; \quad (M_A)_y = 0 \quad \text{Ans}$$

$$\Sigma M_z = 0; \quad (M_A)_z + 200(2.5) = 0 \\ (M_A)_z = -500 \text{ N} \cdot \text{m} \quad \text{Ans}$$

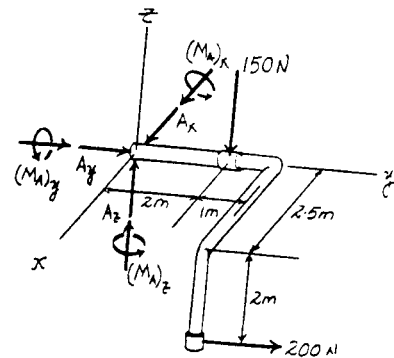

The negative signs indicate that the direction of the reaction components are in the opposite sense of those shown on FBD.

5-100. The horizontal beam is supported by springs at its ends. If the stiffness of the spring at A is $k_A = 5 \text{ kN/m}$, determine the required stiffness of the spring at B so that if the beam is loaded with the 800-N force, it remains in the horizontal position both before and after loading.

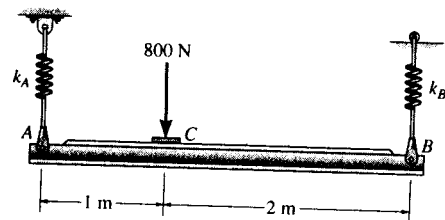

Equilibrium :

$$\left(\begin{array}{l} + \\ - \end{array} \right) \Sigma M_A = 0; \quad F_B(3) - 800(1) = 0 \quad F_B = 266.67 \text{ N}$$

$$\left(\begin{array}{l} + \\ - \end{array} \right) \Sigma M_B = 0; \quad 800(2) - F_A(3) = 0 \quad F_A = 533.33 \text{ N}$$

Spring force formula : $x = \frac{F}{k}$

$$x_A = x_B$$

$$\frac{533.33}{5000} = \frac{266.67}{k_B}$$

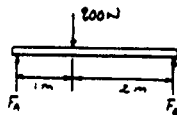

$$k_B = 2500 \text{ N/m} = 2.50 \text{ kN/m} \quad \text{Ans}$$

6-1. Determine the force in each member of the truss and state if the members are in tension or compression. Set $P_1 = 800$ lb and $P_2 = 400$ lb.

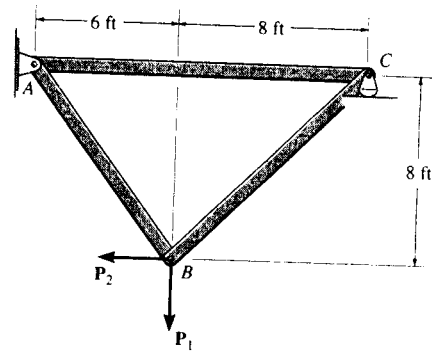

Method of Joints : In this case, the support reactions are not required for determining the member forces.

Joint B

$$\rightarrow \Sigma F_x = 0; \quad F_{BC} \cos 45^\circ - F_{BA} \left(\frac{3}{5}\right) - 400 = 0 \quad [1]$$

$$+ \uparrow \Sigma F_y = 0; \quad F_{BC} \sin 45^\circ + F_{BA} \left(\frac{4}{5}\right) - 800 = 0 \quad [2]$$

Solving Eqs. [1] and [2] yields

$$F_{BA} = 285.71 \text{ lb (T)} = 286 \text{ lb (T)} \quad \text{Ans}$$

$$F_{BC} = 808.12 \text{ lb (T)} = 808 \text{ lb (T)} \quad \text{Ans}$$

Joint C

$$\rightarrow \Sigma F_x = 0; \quad F_{CA} - 808.12 \cos 45^\circ = 0$$

$$F_{CA} = 571 \text{ lb (C)} \quad \text{Ans}$$

$$+ \uparrow \Sigma F_y = 0; \quad C_y - 808.12 \sin 45^\circ = 0$$

$$C_y = 571 \text{ lb}$$

Note : The support reactions A_x and A_y can be determined by analyzing Joint A using the results obtained above.

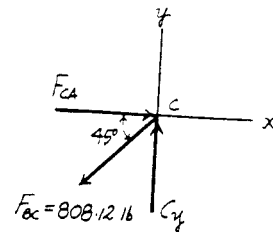
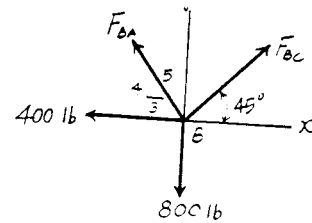

6-2. Determine the force on each member of the truss and state if the members are in tension or compression. Set $P_1 = 500$ lb and $P_2 = 100$ lb.

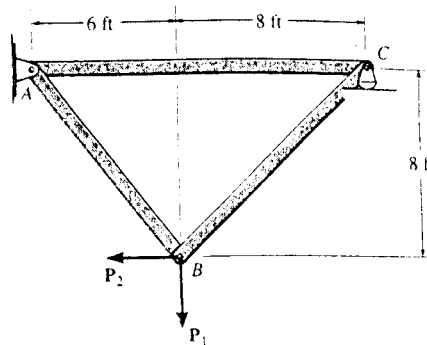

Method of Joints : In this case, the support reactions are not required for determining the member forces.

Joint B

$$\rightarrow \Sigma F_x = 0; \quad F_{BC} \cos 45^\circ - F_{BA} \left(\frac{3}{5}\right) - 100 = 0 \quad [1]$$

$$+ \uparrow \Sigma F_y = 0; \quad F_{BC} \sin 45^\circ + F_{BA} \left(\frac{4}{5}\right) - 500 = 0 \quad [2]$$

Solving Eqs. [1] and [2] yields

$$F_{BA} = 285.71 \text{ lb (T)} = 286 \text{ lb (T)} \quad \text{Ans}$$

$$F_{BC} = 383.86 \text{ lb (T)} = 384 \text{ lb (T)} \quad \text{Ans}$$

Joint C

$$\rightarrow \Sigma F_x = 0; \quad F_{CA} - 383.86 \cos 45^\circ = 0$$

$$F_{CA} = 271 \text{ lb (C)} \quad \text{Ans}$$

$$+ \uparrow \Sigma F_y = 0; \quad C_y - 383.86 \sin 45^\circ = 0$$

$$C_y = 271.43 \text{ lb}$$

Note : The support reactions A_x and A_y can be determined by analyzing Joint A using the results obtained above.

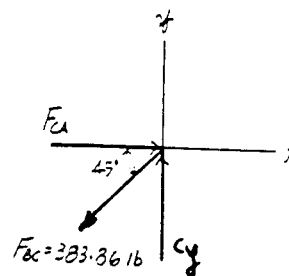
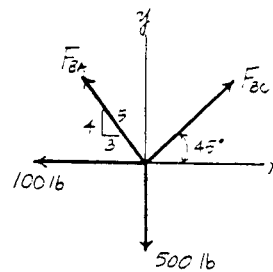

6-3. The truss, used to support a balcony, is subjected to the loading shown. Approximate each joint as a pin and determine the force in each member. State whether the members are in tension or compression. Set $P_1 = 600$ lb, $P_2 = 400$ lb.

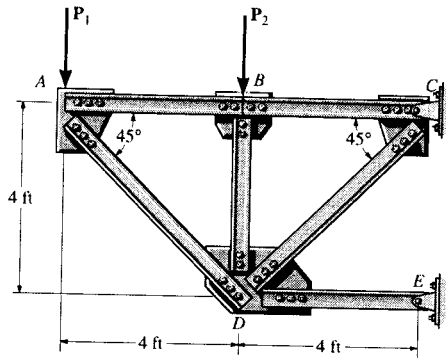

Joint A:

$$+\uparrow \Sigma F_y = 0; F_{AD} \sin 45^\circ - 600 = 0$$

$$F_{AD} = 848.528 = 849 \text{ lb(C)} \quad \text{Ans}$$

$$\rightarrow \Sigma F_x = 0; F_{AB} - 848.528 \cos 45^\circ = 0$$

$$F_{AB} = 600 \text{ lb(T)} \quad \text{Ans}$$

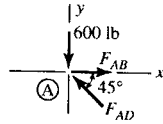

Joint B:

$$+\uparrow \Sigma F_y = 0; F_{BD} - 400 = 0$$

$$F_{BD} = 400 \text{ lb(C)} \quad \text{Ans}$$

$$\rightarrow \Sigma F_x = 0; F_{BC} - 600 = 0$$

$$F_{BC} = 600 \text{ lb(T)} \quad \text{Ans}$$

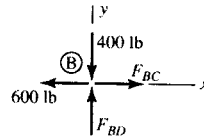

Joint D:

$$+\uparrow \Sigma F_y = 0; F_{DC} \sin 45^\circ - 400 - 848.528 \sin 45^\circ = 0$$

$$F_{DC} = 1414.214 \text{ lb} = 1.41 \text{ kip(T)} \quad \text{Ans}$$

$$\rightarrow \Sigma F_x = 0; 848.528 \cos 45^\circ + 1414.214 \cos 45^\circ - F_{DE} = 0$$

$$F_{DE} = 1600 \text{ lb} = 1.60 \text{ kip(C)} \quad \text{Ans}$$

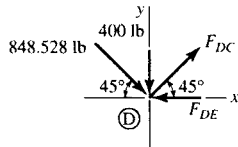

*6-4. The truss, used to support a balcony, is subjected to the loading shown. Approximate each joint as a pin and determine the force in each member. State whether the members are in tension or compression. Set $P_1 = 800 \text{ lb}$, $P_2 = 0$.

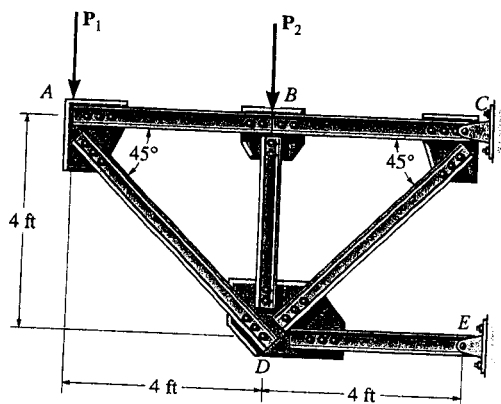

Joint A :

$$+\uparrow \Sigma F_y = 0; \quad F_{AD} \sin 45^\circ - 800 = 0$$

$$F_{AD} = 1131.4 \text{ lb} = 1.13 \text{ kip (C)} \quad \text{Ans}$$

$$\rightarrow \Sigma F_x = 0; \quad F_{AB} - 1131.4 \cos 45^\circ = 0$$

$$F_{AB} = 800 \text{ lb (T)} \quad \text{Ans}$$

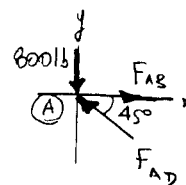

Joint B :

$$+\uparrow \Sigma F_y = 0; \quad F_{BD} - 0 = 0$$

$$F_{BD} = 0 \quad \text{Ans}$$

$$\rightarrow \Sigma F_x = 0; \quad F_{BC} - 800 = 0$$

$$F_{BC} = 800 \text{ lb (T)} \quad \text{Ans}$$

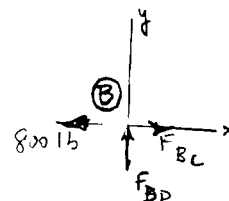

Joint D :

$$+\uparrow \Sigma F_y = 0; \quad F_{DC} \sin 45^\circ - 0 - 1131.4 \sin 45^\circ = 0$$

$$F_{DC} = 1131.4 \text{ lb} = 1.13 \text{ kip (T)} \quad \text{Ans}$$

$$\rightarrow \Sigma F_x = 0; \quad 1131.4 \cos 45^\circ + 1131.4 \cos 45^\circ - F_{DE} = 0$$

$$F_{DE} = 1600 \text{ lb} = 1.60 \text{ kip (C)} \quad \text{Ans}$$

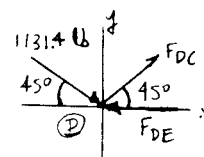

6-5. Determine the force in each member of the truss and state if the members are in tension or compression. Assume each joint as a pin. Set $P = 4$ kN.

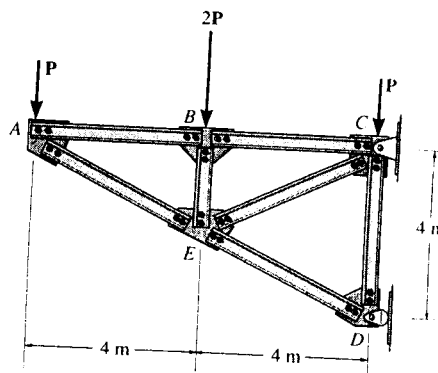

Method of Joints : In this case, the support reactions are not required for determining the member forces.

Joint A

$$+\uparrow \Sigma F_y = 0; \quad F_{AE} \left(\frac{1}{\sqrt{5}} \right) - 4 = 0$$

$$F_{AE} = 8.944 \text{ kN (C)} = 8.94 \text{ kN (C)} \quad \text{Ans}$$

$$\rightarrow \Sigma F_x = 0; \quad F_{AB} - 8.944 \left(\frac{2}{\sqrt{5}} \right) = 0$$

$$F_{AB} = 8.00 \text{ kN (T)} \quad \text{Ans}$$

Joint B

$$\rightarrow \Sigma F_x = 0; \quad F_{BC} - 8.00 = 0 \quad F_{BC} = 8.00 \text{ kN (T)} \quad \text{Ans}$$

$$+\uparrow \Sigma F_y = 0; \quad F_{BE} - 8 = 0 \quad F_{BE} = 8.00 \text{ kN (C)} \quad \text{Ans}$$

Joint E

$$+\Sigma F_y = 0; \quad F_{EC} \cos 36.87^\circ - 8.00 \cos 26.57^\circ = 0$$

$$F_{EC} = 8.944 \text{ kN (T)} = 8.94 \text{ kN (T)} \quad \text{Ans}$$

$$+\Sigma F_x = 0; \quad 8.944 + 8.00 \sin 26.57^\circ + 8.944 \sin 36.87^\circ - F_{ED} = 0$$

$$F_{ED} = 17.89 \text{ kN (C)} = 17.9 \text{ kN (C)} \quad \text{Ans}$$

Joint D

$$+\uparrow \Sigma F_y = 0; \quad F_{DC} - 17.89 \left(\frac{1}{\sqrt{5}} \right) = 0 \quad F_{DC} = 8.00 \text{ kN (T)} \quad \text{Ans}$$

$$\rightarrow \Sigma F_x = 0; \quad -D_x + 17.89 \left(\frac{2}{\sqrt{5}} \right) = 0 \quad D_x = 16.0 \text{ kN}$$

Note : The support reactions C_x and C_y can be determined by analysing Joint C using the results obtained above.

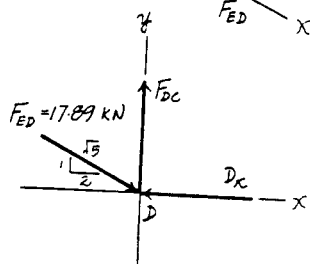
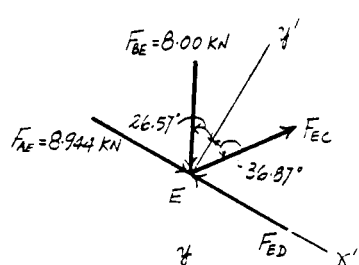
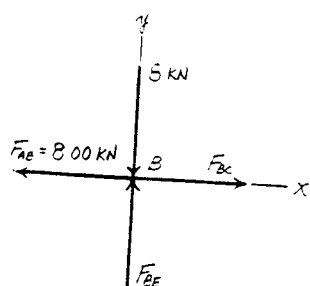
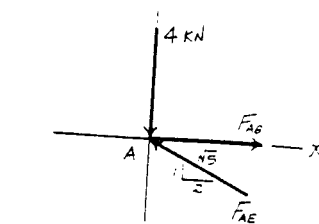

6-6. Assume that each member of the truss is made of steel having a mass per length of 4 kg/m. Set $P = 0$, determine the force in each member, and indicate if the members are in tension or compression. Neglect the weight of the gusset plates and assume each joint is a pin. Solve the problem by assuming the weight of each member can be represented as a vertical force, half of which is applied at the end of each member.

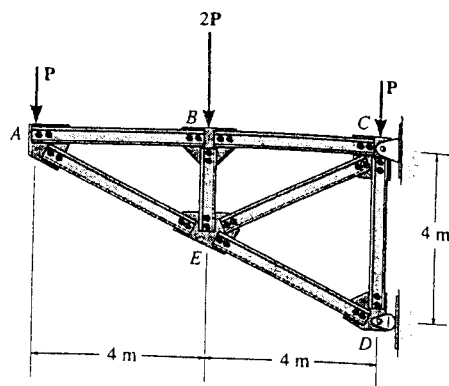

Joint Forces :

$$F_A = 4(9.81) \left(2 + \frac{\sqrt{20}}{2} \right) = 166.22 \text{ N}$$

$$F_B = 4(9.81)(2 + 2 + 1) = 196.2 \text{ N}$$

$$F_E = 4(9.81) \left[1 + 3 \left(\frac{\sqrt{20}}{2} \right) \right] = 302.47 \text{ N}$$

$$F_D = 4(9.81) \left(2 + \frac{\sqrt{20}}{2} \right) = 166.22 \text{ N}$$

Method of Joints : In this case, the support reactions are not required for determining the member forces.

Joint A

$$+\uparrow \Sigma F_y = 0; \quad F_{AE} \left(\frac{1}{\sqrt{5}} \right) - 166.22 = 0$$

$$F_{AE} = 371.69 \text{ N (C)} = 372 \text{ N (C)} \quad \text{Ans}$$

$$\rightarrow \Sigma F_x = 0; \quad F_{AB} - 371.69 \left(\frac{2}{\sqrt{5}} \right) = 0$$

$$F_{AB} = 332.45 \text{ N (T)} = 332 \text{ N (T)} \quad \text{Ans}$$

Joint B

$$\rightarrow \Sigma F_x = 0; \quad F_{BC} - 332.45 = 0 \quad F_{BC} = 332 \text{ N (T)} \quad \text{Ans}$$

$$+\uparrow \Sigma F_y = 0; \quad F_{BE} - 196.2 = 0$$

$$F_{BE} = 196.2 \text{ N (C)} = 196 \text{ N (C)} \quad \text{Ans}$$

Joint E

$$\nearrow \Sigma F_y = 0; \quad F_{EC} \cos 36.87^\circ - (196.2 + 302.47) \cos 26.57^\circ = 0$$

$$F_{EC} = 557.53 \text{ N (T)} = 558 \text{ N (T)} \quad \text{Ans}$$

$$\searrow \Sigma F_x = 0; \quad 371.69 + (196.2 + 302.47) \sin 26.57^\circ + 557.53 \sin 36.87^\circ - F_{ED} = 0$$

$$F_{ED} = 929.22 \text{ N (C)} = 929 \text{ N (C)} \quad \text{Ans}$$

Joint D

$$+\uparrow \Sigma F_y = 0; \quad F_{DC} - 929.22 \left(\frac{1}{\sqrt{5}} \right) - 166.22 = 0$$

$$F_{DC} = 582 \text{ N (T)} \quad \text{Ans}$$

$$\rightarrow \Sigma F_x = 0; \quad D_x - 929.22 \left(\frac{2}{\sqrt{5}} \right) = 0 \quad D_x = 831.12 \text{ N}$$

Note : The support reactions C_x and C_y can be determined by analyzing Joint C using the results obtained above.

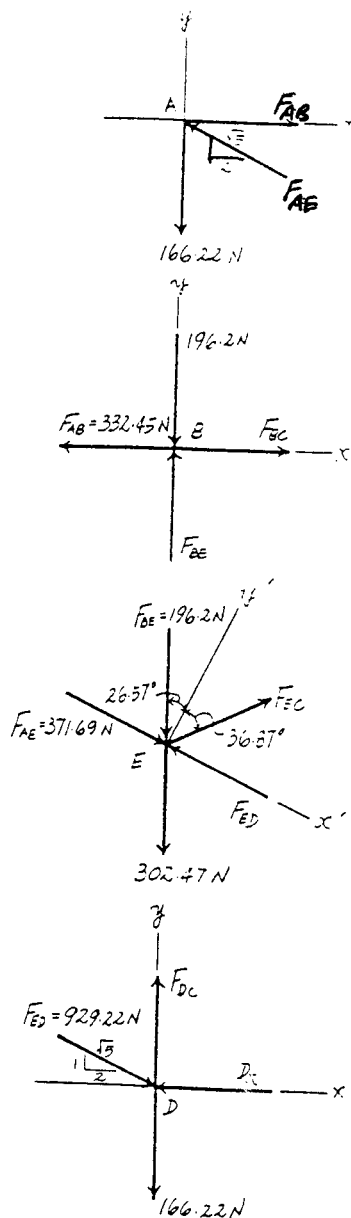

6-7. Determine the force in each member of the truss and state if the members are in tension or compression.

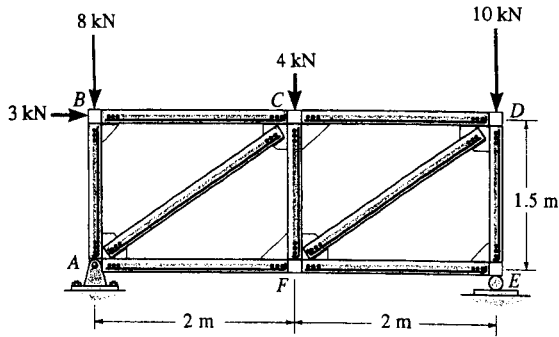

$$(+\Sigma M_A = 0; \quad -3(1.5) - 4(2) - 10(4) + E_y(4) = 0$$

$$E_y = 13.125 \text{ kN}$$

$$+\uparrow \Sigma F_y = 0; \quad A_y - 8 - 4 - 10 + 13.125 = 0$$

$$A_y = 8.875 \text{ kN}$$

$$\rightarrow \Sigma F_x = 0; \quad A_x = 3 \text{ kN}$$

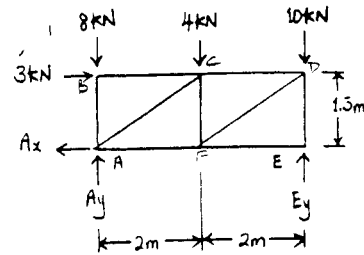

Joint B :

$$\rightarrow \Sigma F_x = 0; \quad F_{BC} = 3 \text{ kN (C)} \quad \text{Ans}$$

$$+\uparrow \Sigma F_y = 0; \quad F_{BA} = 8 \text{ kN (C)} \quad \text{Ans}$$

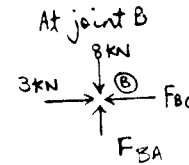

Joint A :

$$+\uparrow \Sigma F_y = 0; \quad 8.875 - 8 - \frac{3}{5}F_{AC} = 0$$

$$F_{AC} = 1.458 = 1.46 \text{ kN (C)} \quad \text{Ans}$$

$$\rightarrow \Sigma F_x = 0; \quad F_{AF} - 3 - \frac{4}{5}(1.458) = 0$$

$$F_{AF} = 4.17 \text{ kN (T)} \quad \text{Ans}$$

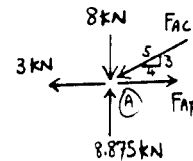

6-7 cont'd

Joint C:

$$\rightarrow \Sigma F_x = 0; \quad 3 + \frac{4}{5}(1.458) - F_{CD} = 0$$

$$F_{CD} = 4.167 = 4.17 \text{ kN (C)}$$

Ans

$$+ \uparrow \Sigma F_y = 0; \quad F_{CF} - 4 + \frac{3}{5}(1.458) = 0$$

$$F_{CF} = 3.125 = 3.12 \text{ kN (C)}$$

Ans

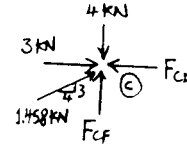

Joint E:

$$\rightarrow \Sigma F_x = 0; \quad F_{EF} = 0$$

Ans

$$+ \uparrow \Sigma F_y = 0; \quad F_{ED} = 13.125 = 13.1 \text{ kN (C)}$$

Ans

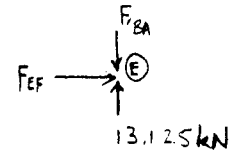

Joint D:

$$+ \uparrow \Sigma F_y = 0; \quad 13.125 - 10 - \frac{3}{5}F_{DF} = 0$$

$$F_{DF} = 5.21 \text{ kN (T)}$$

Ans

$$\rightarrow \Sigma F_x = 0; \quad 4.167 - \frac{4}{5}(5.21) = 0$$

Check!

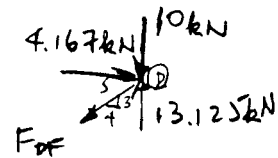

*6-8. Determine the force in each member of the truss and state if the members are in tension or compression. Set $P_1 = 2 \text{ kN}$ and $P_2 = 1.5 \text{ kN}$.

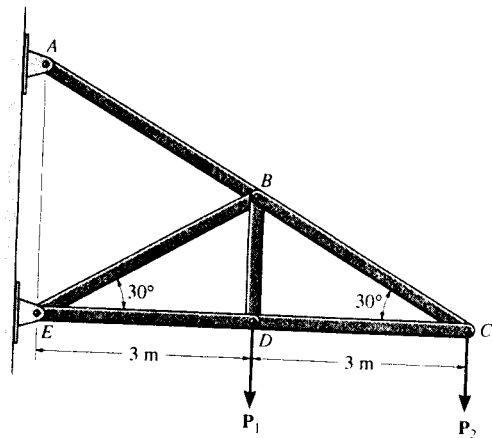

Method of Joints : In this case, the support reactions are not required for determining the member forces.

Joint C

$$+\uparrow \Sigma F_y = 0; \quad F_{CB} \sin 30^\circ - 1.5 = 0$$

$$F_{CB} = 3.00 \text{ kN (T)} \quad \text{Ans}$$

$$\rightarrow \Sigma F_x = 0; \quad F_{CD} - 3.00 \cos 30^\circ = 0$$

$$F_{CD} = 2.598 \text{ kN (C)} = 2.60 \text{ kN (C)} \quad \text{Ans}$$

Joint D

$$\rightarrow \Sigma F_x = 0; \quad F_{DE} - 2.598 = 0 \quad F_{DE} = 2.60 \text{ kN (C)} \quad \text{Ans}$$

$$+\uparrow \Sigma F_y = 0; \quad F_{DB} - 2 = 0 \quad F_{DB} = 2.00 \text{ kN (T)} \quad \text{Ans}$$

Joint B

$$+\nearrow \Sigma F_y = 0; \quad F_{BE} \cos 30^\circ - 2.00 \cos 30^\circ = 0$$

$$F_{BE} = 2.00 \text{ kN (C)} \quad \text{Ans}$$

$$+\searrow \Sigma F_x = 0; \quad (2.00 + 2.00) \sin 30^\circ + 3.00 - F_{BA} = 0$$

$$F_{BA} = 5.00 \text{ kN (T)} \quad \text{Ans}$$

Note : The support reactions at support A and E can be determined by analyzing Joints A and E respectively using the results obtained above.

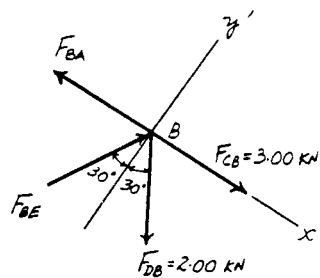
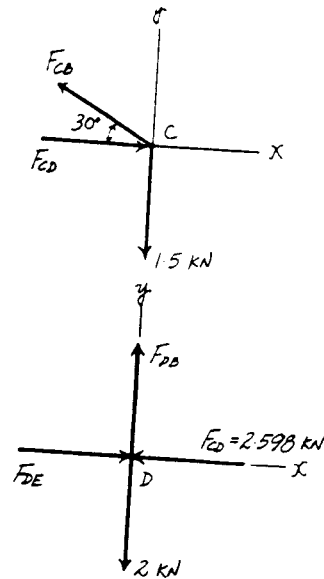

6-9. Determine the force in each member of the truss and state if the members are in tension or compression. Set $P_1 = P_2 = 4 \text{ kN}$.

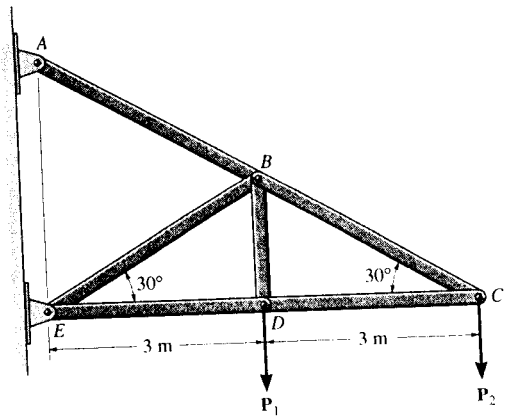

Method of Joints : In this case, the support reactions are not required for determining the member forces.

Joint C

$$+\uparrow \Sigma F_y = 0; \quad F_{CB} \sin 30^\circ - 4 = 0$$

$$F_{CB} = 8.00 \text{ kN (T)} \quad \text{Ans}$$

$$\rightarrow \Sigma F_x = 0; \quad F_{CD} - 8.00 \cos 30^\circ = 0$$

$$F_{CD} = 6.928 \text{ kN (C)} = 6.93 \text{ kN (C)} \quad \text{Ans}$$

Joint D

$$\rightarrow \Sigma F_x = 0; \quad F_{DE} - 6.928 = 0 \quad F_{DE} = 6.93 \text{ kN (C)} \quad \text{Ans}$$

$$+\uparrow \Sigma F_y = 0; \quad F_{DB} - 4 = 0 \quad F_{DB} = 4.00 \text{ kN (T)} \quad \text{Ans}$$

Joint B

$$\nearrow \Sigma F_y = 0; \quad F_{BE} \cos 30^\circ - 4.00 \cos 30^\circ = 0$$

$$F_{BE} = 4.00 \text{ kN (C)} \quad \text{Ans}$$

$$\swarrow \Sigma F_x = 0; \quad (4.00 + 4.00) \sin 30^\circ + 8.00 - F_{BA} = 0$$

$$F_{BA} = 12.0 \text{ kN (T)} \quad \text{Ans}$$

Note : The support reactions at support A and E can be determined by analyzing Joints A and E respectively using the results obtained above.

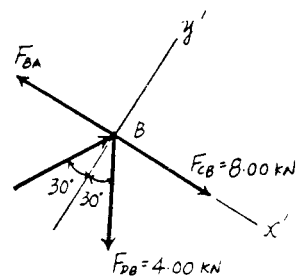
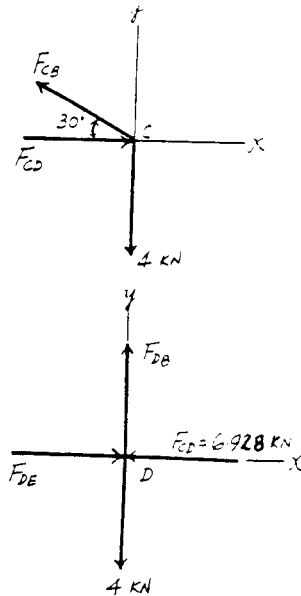

6-10. Determine the force in each member of the truss and state if the members are in tension or compression. Set $P_1 = 0$, $P_2 = 1000$ lb.

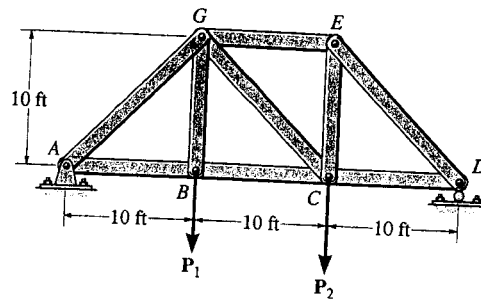

Reactions at A and D :

$$A_x = 0$$

$$A_y = 333.3 \text{ lb}$$

$$D_y = 666.7 \text{ lb}$$

Joint A :

$$\rightarrow \Sigma F_x = 0; \quad F_{AB} - F_{AG} \cos 45^\circ = 0$$

$$+ \uparrow \Sigma F_y = 0; \quad 333.3 - F_{AG} \sin 45^\circ = 0$$

$$F_{AG} = 471 \text{ lb (C)} \quad \text{Ans}$$

$$F_{AB} = 333 \text{ lb (T)} \quad \text{Ans}$$

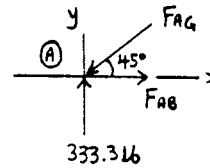

Joint B :

$$F_{BG} = 0 \quad \text{Ans}$$

$$F_{BC} = 333 \text{ lb (T)} \quad \text{Ans}$$

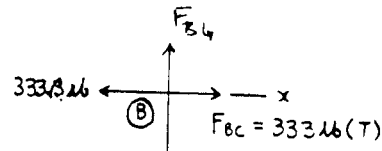

Joint D :

$$\rightarrow \Sigma F_x = 0; \quad -F_{DC} + F_{DE} \cos 45^\circ = 0$$

$$+ \uparrow \Sigma F_y = 0; \quad 666.7 - F_{DE} \sin 45^\circ = 0$$

$$F_{DE} = 942.9 = 943 \text{ lb (C)} \quad \text{Ans}$$

$$F_{DC} = 666.7 = 667 \text{ lb (T)} \quad \text{Ans}$$

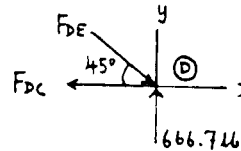

Joint E :

$$\rightarrow \Sigma F_x = 0; \quad F_{EG} - 942.9 \sin 45^\circ = 0$$

$$+ \uparrow \Sigma F_y = 0; \quad -F_{EC} + 942.9 \cos 45^\circ = 0$$

$$F_{EC} = 666.7 = 667 \text{ lb (T)} \quad \text{Ans}$$

$$F_{EG} = 666.7 = 667 \text{ lb (C)} \quad \text{Ans}$$

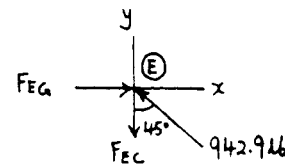

Joint C :

$$+ \uparrow \Sigma F_y = 0; \quad F_{CG} \cos 45^\circ + 666.7 - 1000 = 0$$

$$F_{CG} = 471 \text{ lb (T)} \quad \text{Ans}$$

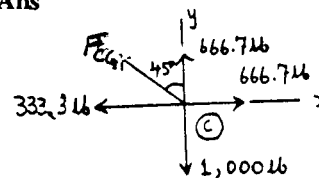

6-11. Determine the force in each member of the truss and state if the members are in tension or compression. Set $P_1 = 500$ lb, $P_2 = 1500$ lb.

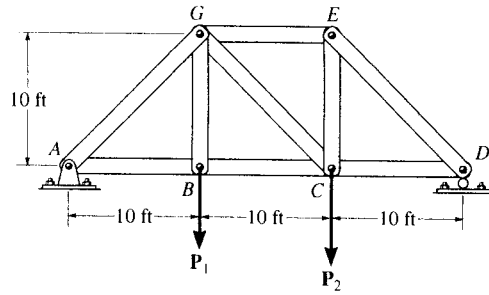

Reactions at A and D :

$$A_x = 0$$

$$A_y = 833.33 \text{ lb}$$

$$D_y = 1166.67 \text{ lb}$$

Joint A :

$$\rightarrow \Sigma F_x = 0; \quad F_{AB} - F_{AG} \cos 45^\circ = 0$$

$$+ \uparrow \Sigma F_y = 0; \quad 833.33 - F_{AG} \sin 45^\circ = 0$$

$$F_{AG} = 1178.51 = 1179 \text{ lb (C)} \quad \text{Ans}$$

$$F_{AB} = 833.33 = 833 \text{ lb (T)} \quad \text{Ans}$$

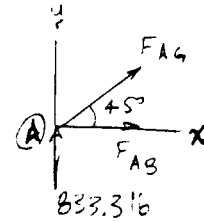

Joint B :

$$\rightarrow \Sigma F_x = 0; \quad F_{BC} - 833 = 0$$

$$+ \uparrow \Sigma F_y = 0; \quad F_{BG} - 500 = 0$$

$$F_{BC} = 833 \text{ lb (T)} \quad \text{Ans}$$

$$F_{BG} = 500 \text{ lb (T)} \quad \text{Ans}$$

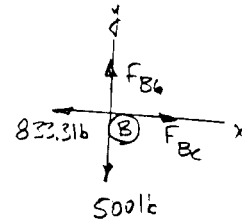

Joint D :

$$\rightarrow \Sigma F_x = 0; \quad -F_{DC} + F_{DE} \cos 45^\circ = 0$$

$$+ \uparrow \Sigma F_y = 0; \quad 1166.67 - F_{DE} \sin 45^\circ = 0$$

$$F_{DE} = 1649.96 = 1650 \text{ lb (C)} \quad \text{Ans}$$

$$F_{DC} = 1166.67 = 1167 \text{ lb (T)} \quad \text{Ans}$$

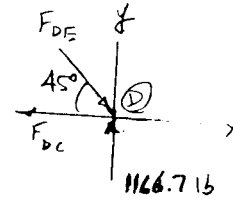

Joint E :

$$\rightarrow \Sigma F_x = 0; \quad F_{EG} - 1649.96 \sin 45^\circ = 0$$

$$+ \uparrow \Sigma F_y = 0; \quad -F_{EC} + 1649.96 \cos 45^\circ = 0$$

$$F_{EC} = 1166.67 = 1167 \text{ lb (T)} \quad \text{Ans}$$

$$F_{EG} = 1166.67 = 1167 \text{ lb (C)} \quad \text{Ans}$$

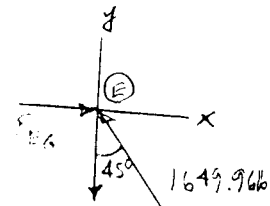

Joint C :

$$+ \uparrow \Sigma F_y = 0; \quad F_{CG} \cos 45^\circ + 1166.67 - 1500 = 0$$

$$F_{CG} = 470.93 = 471 \text{ lb (T)} \quad \text{Ans}$$

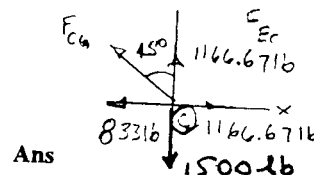

*6-12. Determine the force in each member of the truss and state if the members are in tension or compression. Set $P_1 = 10 \text{ kN}$, $P_2 = 15 \text{ kN}$.

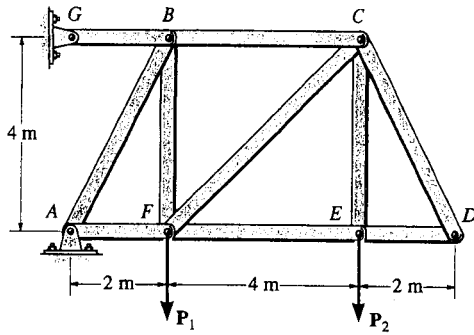

Probs. 6-12/13

$$\curvearrowright + \Sigma M_A = 0; \quad G_x(4) - 10(2) - 15(6) = 0$$

$$G_x = 27.5 \text{ kN}$$

$$\rightarrow \Sigma F_x = 0; \quad A_x - 27.5 = 0$$

$$A_x = 27.5 \text{ kN}$$

$$+ \uparrow \Sigma F_y = 0; \quad A_y - 10 - 15 = 0$$

$$A_y = 25 \text{ kN}$$

Joint G :

$$\rightarrow \Sigma F_x = 0; \quad F_{GB} - 27.5 = 0$$

$$F_{GB} = 27.5 \text{ kN (T)}$$

Ans

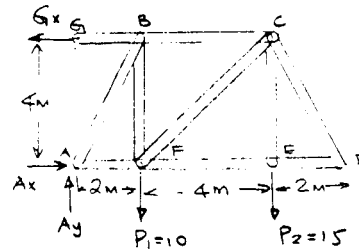

Joint A :

$$\rightarrow \Sigma F_x = 0; \quad 27.5 - F_{AF} - \frac{1}{\sqrt{5}}(F_{AB}) = 0$$

$$+ \uparrow \Sigma F_y = 0; \quad 25 - F_{AB}\left(\frac{2}{\sqrt{5}}\right) = 0$$

$$F_{AF} = 15.0 \text{ kN (C)}$$

Ans

$$F_{AB} = 27.95 = 28.0 \text{ kN (C)}$$

Ans

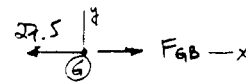

Joint B :

$$\rightarrow \Sigma F_x = 0; \quad 27.95\left(\frac{1}{\sqrt{5}}\right) + F_{BC} - 27.5 = 0$$

$$+ \uparrow \Sigma F_y = 0; \quad 27.95\left(\frac{2}{\sqrt{5}}\right) - F_{BF} = 0$$

$$F_{BF} = 24.99 = 25.0 \text{ kN (T)}$$

Ans

$$F_{BC} = 15.0 \text{ kN (T)}$$

Ans

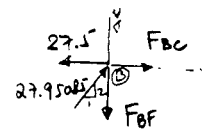

6-12 cont'd

Joint F:

$$\rightarrow \Sigma F_x = 0; \quad 15 + F_{FE} - \frac{1}{\sqrt{2}}(F_{FC}) = 0$$

$$+ \uparrow \Sigma F_y = 0; \quad 25 - 10 - F_{FC}\left(\frac{1}{\sqrt{2}}\right) = 0$$

$$F_{FC} = 21.21 = 21.2 \text{ kN (C)}$$

Ans

$$F_{FE} = 0$$

Ans

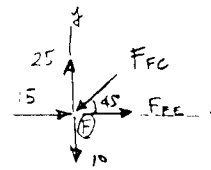

Joint E:

$$\rightarrow \Sigma F_x = 0; \quad F_{ED} = 0$$

Ans

$$+ \uparrow \Sigma F_y = 0; \quad F_{EC} - 15 = 0$$

$$F_{EC} = 15.0 \text{ kN (T)}$$

Ans

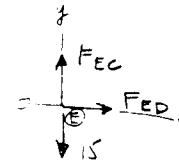

Joint D:

$$\rightarrow \Sigma F_x = 0; \quad F_{DC} = 0$$

Ans

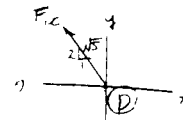

6-13. Determine the force in each member of the truss and state if the members are in tension or compression. Set $P_1 = 0$, $P_2 = 20$ kN.

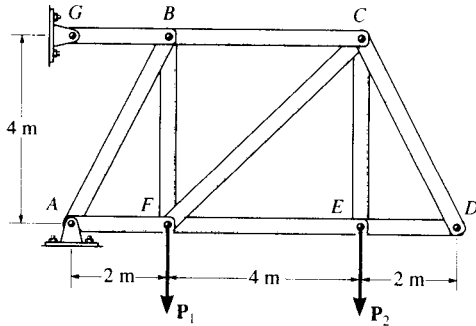

$$\curvearrowleft + \Sigma M_A = 0; \quad F_{GB}(4) - 20(6) = 0$$

$$F_{GB} = 30 \text{ kN (T)}$$

Ans

$$\rightarrow \Sigma F_x = 0; \quad A_x - 30 = 0$$

$$A_x = 30 \text{ kN}$$

$$+\uparrow \Sigma F_y = 0; \quad A_y - 20 = 0$$

$$A_y = 20 \text{ kN}$$

Joint A :

$$\rightarrow \Sigma F_x = 0; \quad 30 - F_{AF} - \frac{1}{\sqrt{5}}(F_{AB}) = 0$$

$$+\uparrow \Sigma F_y = 0; \quad 20 - F_{AB}\left(\frac{2}{\sqrt{5}}\right) = 0$$

$$F_{AF} = 20 \text{ kN (C)}$$

Ans

$$F_{AB} = 22.36 = 22.4 \text{ kN (C)}$$

Ans

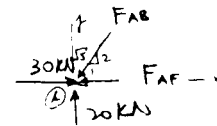
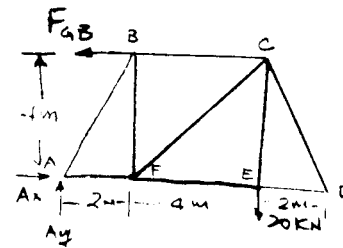

6-13 cont.

Joint B :

$$\rightarrow \Sigma F_x = 0; \quad 22.36\left(\frac{1}{\sqrt{5}}\right) + F_{BC} - 30 = 0$$

$$+ \uparrow \Sigma F_y = 0; \quad 22.36\left(\frac{2}{\sqrt{5}}\right) - F_{BF} = 0$$

$$F_{BF} = 20 \text{ kN (T)} \quad \text{Ans}$$

$$F_{BC} = 20 \text{ kN (T)} \quad \text{Ans}$$

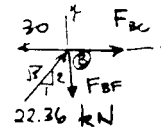

Joint F :

$$\rightarrow \Sigma F_x = 0; \quad 20 + F_{FE} - \frac{1}{\sqrt{2}}(F_{FC}) = 0$$

$$+ \uparrow \Sigma F_y = 0; \quad 20 - F_{FC}\left(\frac{1}{\sqrt{2}}\right) = 0$$

$$F_{FC} = 28.28 = 28.3 \text{ kN (C)} \quad \text{Ans}$$

$$F_{FE} = 0 \quad \text{Ans}$$

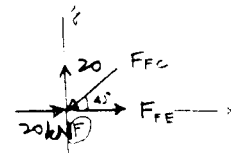

Joint E :

$$\rightarrow \Sigma F_x = 0; \quad F_{ED} - 0 = 0$$

$$+ \uparrow \Sigma F_y = 0; \quad F_{EC} - 20 = 0$$

$$F_{ED} = 0 \quad \text{Ans}$$

$$F_{EC} = 20.0 \text{ kN (T)} \quad \text{Ans}$$

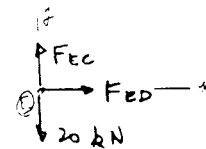

Joint D :

$$\rightarrow \Sigma F_x = 0; \quad \frac{1}{\sqrt{5}}(F_{DC}) - 0 = 0$$

$$F_{DC} = 0 \quad \text{Ans}$$

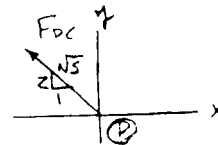

6-14. Determine the force in each member of the truss and state if the members are in tension or compression. Set $P_1 = 100 \text{ lb}$, $P_2 = 200 \text{ lb}$, $P_3 = 300 \text{ lb}$.

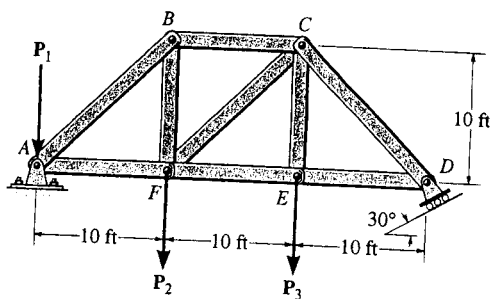

$$\curvearrowleft + \Sigma M_A = 0; \quad 200(10) + 300(20) - R_D \cos 30^\circ(30) = 0$$

$$R_D = 307.9 \text{ lb}$$

$$+ \uparrow \Sigma F_y = 0; \quad A_y - 100 - 200 - 300 + 307.9 \cos 30^\circ = 0$$

$$A_y = 333.4 \text{ lb}$$

$$\rightarrow \Sigma F_x = 0; \quad A_x - 307.9 \sin 30^\circ = 0$$

$$A_x = 154.0 \text{ lb}$$

Joint A :

$$+ \uparrow \Sigma F_y = 0; \quad 333.4 - 100 - \frac{1}{\sqrt{2}} F_{AB} = 0$$

$$F_{AB} = 330 \text{ lb (C)}$$

Ans

$$\rightarrow \Sigma F_x = 0; \quad 154.0 + F_{AF} - \frac{1}{\sqrt{2}}(330) = 0$$

$$F_{AF} = 79.37 = 79.4 \text{ lb (T)}$$

Ans

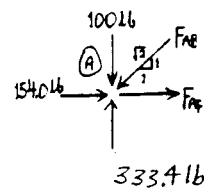
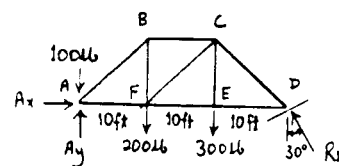

Con'd

6-14 cont'd

Joint B :

$$+\uparrow \Sigma F_y = 0; \quad \frac{1}{\sqrt{2}}(330) - F_{BF} = 0$$

$$F_{BF} = 233.3 = 233 \text{ lb (T)}$$

Ans

$$\rightarrow \Sigma F_x = 0; \quad \frac{1}{\sqrt{2}}(330) - F_{BC} = 0$$

$$F_{BC} = 233.3 = 233 \text{ lb (C)}$$

Ans

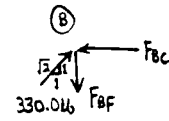

Joint F :

$$+\uparrow \Sigma F_y = 0; \quad -\frac{1}{\sqrt{2}}F_{FC} - 200 + 233.3 = 0$$

$$F_{FC} = 47.14 = 47.1 \text{ lb (C)}$$

Ans

$$\rightarrow \Sigma F_x = 0; \quad F_{FE} - 79.37 - \frac{1}{\sqrt{2}}(47.14) = 0$$

$$F_{FE} = 112.7 = 113 \text{ lb (T)}$$

Ans

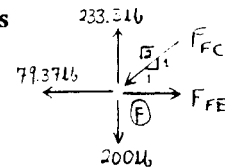

Joint E :

$$\rightarrow \Sigma F_x = 0; \quad F_{EC} = 300 \text{ lb (T)}$$

Ans

$$+\uparrow \Sigma F_y = 0; \quad F_{ED} = 112.7 = 113 \text{ lb (T)}$$

Ans

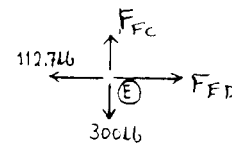

Joint C :

$$\rightarrow \Sigma F_x = 0; \quad \frac{1}{\sqrt{2}}(47.14) + 233.3 - \frac{1}{\sqrt{2}}F_{CD} = 0$$

$$F_{CD} = 377.1 = 377 \text{ lb (C)}$$

Ans

$$+\uparrow \Sigma F_y = 0; \quad \frac{1}{\sqrt{2}}(47.14) - 300 + \frac{1}{\sqrt{2}}(377.1) = 0$$

Check!

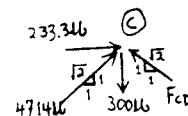

6-15. Determine the force in each member of the truss and state if the members are in tension or compression.
 Set $P_1 = 400 \text{ lb}$, $P_2 = 400 \text{ lb}$, $P_3 = 0$.

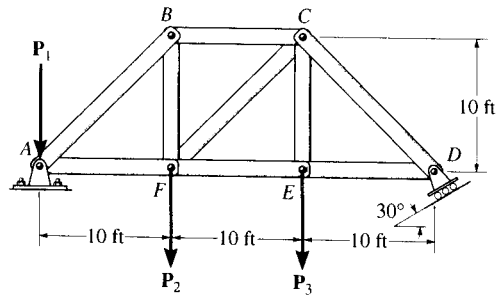

$$\curvearrowright + \Sigma M_A = 0; \quad -400(10) + R_D \cos 30^\circ(30) = 0$$

$$R_D = 153.96 \text{ lb}$$

$$+ \uparrow \Sigma F_y = 0; \quad A_y - 400 - 400 + 153.96 \cos 30^\circ = 0$$

$$A_y = 666.67 \text{ lb}$$

$$\rightarrow \Sigma F_x = 0; \quad A_x - 153.96 \sin 30^\circ = 0$$

$$A_x = 76.98 \text{ lb}$$

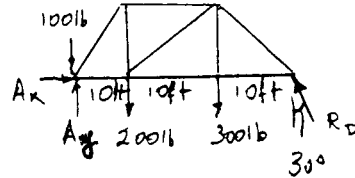

Joint A :

$$+ \uparrow \Sigma F_y = 0; \quad 666.67 - 400 - \frac{1}{\sqrt{2}} F_{AB} = 0$$

$$F_{AB} = 377.12 = 377 \text{ lb (C)}$$

Ans

$$\rightarrow \Sigma F_x = 0; \quad 76.98 + F_{AF} - \frac{1}{\sqrt{2}}(377.12) = 0$$

$$F_{AF} = 189.68 = 190 \text{ lb (T)}$$

Ans

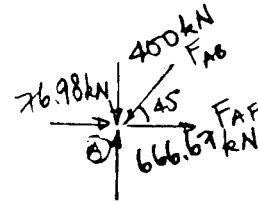

Joint B :

$$+ \uparrow \Sigma F_y = 0; \quad \frac{1}{\sqrt{2}}(377.12) - F_{BF} = 0$$

$$F_{BF} = 266.67 = 267 \text{ lb (T)}$$

Ans

$$\rightarrow \Sigma F_x = 0; \quad \frac{1}{\sqrt{2}}(377.12) - F_{BC} = 0$$

$$F_{BC} = 266.67 = 267 \text{ lb (C)}$$

Ans



Con'd

6-13 cont'd

Joint F:

$$+\uparrow \Sigma F_y = 0; \quad \frac{1}{\sqrt{2}} F_{FC} - 400 + 266.67 = 0$$

$$F_{FC} = 188.56 = 189 \text{ lb (T)} \quad \text{Ans}$$

$$\rightarrow \Sigma F_x = 0; \quad F_{FE} - 190 + \frac{1}{\sqrt{2}} (188.56) = 0$$

$$F_{FE} = 56.68 = 56.7 \text{ lb (T)} \quad \text{Ans}$$

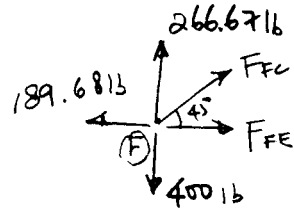

Joint E:

$$\rightarrow \Sigma F_x = 0; \quad F_{ED} = 56.7 \text{ lb (T)} \quad \text{Ans}$$

$$+\uparrow \Sigma F_y = 0; \quad F_{EC} = 0 \quad \text{Ans}$$

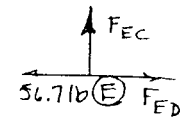

Joint C:

$$\rightarrow \Sigma F_x = 0; \quad -\frac{1}{\sqrt{2}} (188.56) + 266.67 - \frac{1}{\sqrt{2}} F_{CD} = 0$$

$$F_{CD} = 188.57 = 189 \text{ lb (C)} \quad \text{Ans}$$

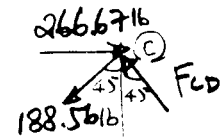

*6-16. Determine the force in each member of the truss. State whether the members are in tension or compression. Set $P = 8$ kN.

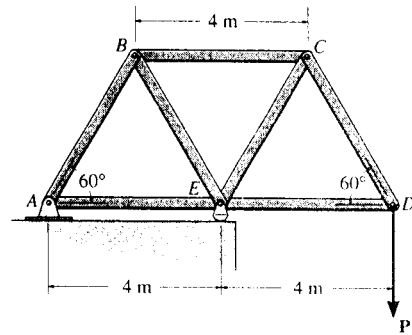

Method of Joints : In this case, the support reactions are not required for determining the member forces.

Joint D

$$+\uparrow \Sigma F_y = 0; \quad F_{DC} \sin 60^\circ - 8 = 0$$

$$F_{DC} = 9.238 \text{ kN (T)} = 9.24 \text{ kN (T)} \quad \text{Ans}$$

$$\rightarrow \Sigma F_x = 0; \quad F_{DE} - 9.238 \cos 60^\circ = 0$$

$$F_{DE} = 4.619 \text{ kN (C)} = 4.62 \text{ kN (C)} \quad \text{Ans}$$

Joint C

$$+\uparrow \Sigma F_y = 0; \quad F_{CE} \sin 60^\circ - 9.238 \sin 60^\circ = 0$$

$$F_{CE} = 9.238 \text{ kN (C)} = 9.24 \text{ kN (C)} \quad \text{Ans}$$

$$\rightarrow \Sigma F_x = 0; \quad 2(9.238 \cos 60^\circ) - F_{CB} = 0$$

$$F_{CB} = 9.238 \text{ kN (T)} = 9.24 \text{ kN (T)} \quad \text{Ans}$$

Joint B

$$+\uparrow \Sigma F_y = 0; \quad F_{BE} \sin 60^\circ - F_{BA} \sin 60^\circ = 0$$

$$F_{BE} = F_{BA} = F$$

$$\rightarrow \Sigma F_x = 0; \quad 9.238 - 2F \cos 60^\circ = 0$$

$$F = 9.238 \text{ kN}$$

Thus, $F_{BE} = 9.24 \text{ kN (C)}$ $F_{BA} = 9.24 \text{ kN (T)}$ **Ans**

Joint E

$$+\uparrow \Sigma F_y = 0; \quad E_y - 2(9.238 \sin 60^\circ) = 0 \quad E_y = 16.0 \text{ kN}$$

$$\rightarrow \Sigma F_x = 0; \quad F_{EA} + 9.238 \cos 60^\circ - 9.238 \cos 60^\circ + 4.619 = 0$$

$$F_{EA} = 4.62 \text{ kN (C)} \quad \text{Ans}$$

Note : The support reactions A_x and A_y can be determined by analysing Joint A using the results obtained above.

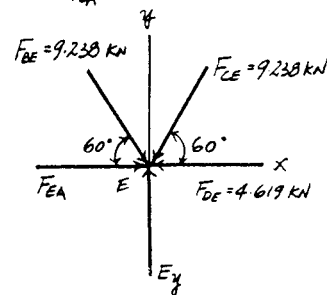
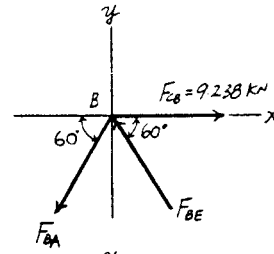
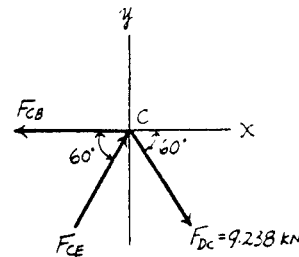
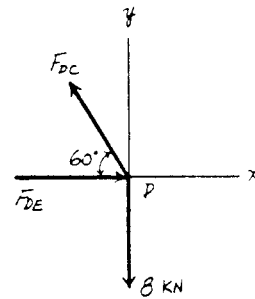

6-17. If the maximum force that any member can support is 8 kN in tension and 6 kN in compression, determine the maximum force P that can be supported at joint D .

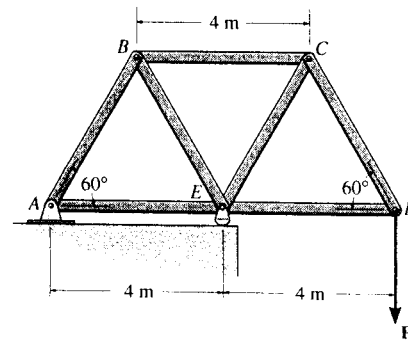

Method of Joints : In this case, the support reactions are not required for determining the member forces.

Joint D

$$+\uparrow \Sigma F_y = 0; \quad F_{DC} \sin 60^\circ - P = 0 \quad F_{DC} = 1.1547P \text{ (T)}$$

$$\rightarrow \Sigma F_x = 0; \quad F_{DE} - 1.1547P \cos 60^\circ = 0 \quad F_{DE} = 0.57735P \text{ (C)}$$

Joint C

$$+\uparrow \Sigma F_y = 0; \quad F_{CE} \sin 60^\circ - 1.1547P \sin 60^\circ = 0 \\ F_{CE} = 1.1547P \text{ (C)}$$

$$\rightarrow \Sigma F_x = 0; \quad 2(1.1547P \cos 60^\circ) - F_{CB} = 0 \quad F_{CB} = 1.1547P \text{ (T)}$$

Joint B

$$+\uparrow \Sigma F_y = 0; \quad F_{BE} \sin 60^\circ - F_{BA} \sin 60^\circ = 0 \quad F_{BE} = F_{BA} = F$$

$$\rightarrow \Sigma F_x = 0; \quad 1.1547P - 2F \cos 60^\circ = 0 \quad F = 1.1547P$$

Thus, $F_{BE} = 1.1547P \text{ (C)}$ $F_{BA} = 1.1547P \text{ (T)}$

Joint E

$$\rightarrow \Sigma F_x = 0; \quad F_{EA} + 1.1547P \cos 60^\circ - 1.1547P \cos 60^\circ + 0.57735P = 0 \\ F_{EA} = 0.57735P \text{ (C)}$$

From the above analysis, the maximum compression and tension in the truss member is 1.1547P. For this case, compression controls which requires

$$1.1547P = 6 \\ P = 5.20 \text{ kN}$$

Ans

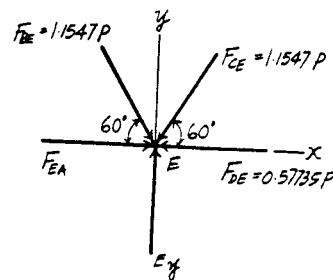
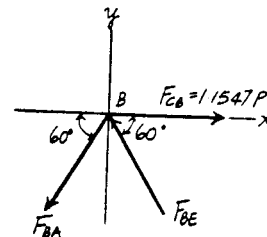
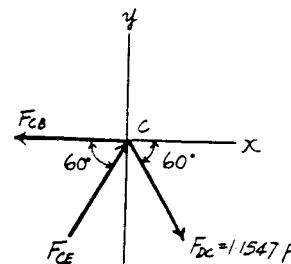
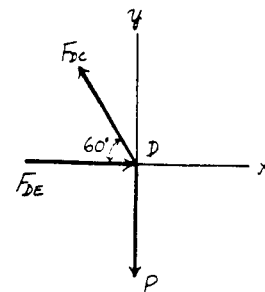

6-18. Determine the force in each member of the truss and state if the members are in tension or compression. *Hint:* The horizontal force component at *A* must be zero. Why?

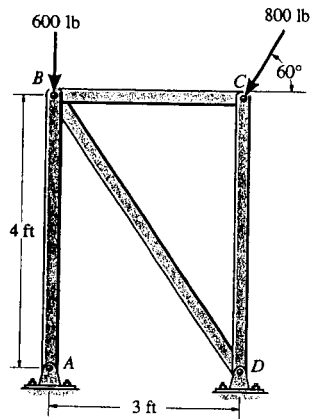

Joint *C* :

$$\rightarrow \Sigma F_x = 0; \quad F_{CB} - 800 \cos 60^\circ = 0$$

$$F_{CB} = 400 \text{ lb (C)} \quad \text{Ans}$$

$$+ \uparrow \Sigma F_y = 0; \quad F_{CD} - 800 \sin 60^\circ = 0$$

$$F_{CD} = 693 \text{ lb (C)} \quad \text{Ans}$$

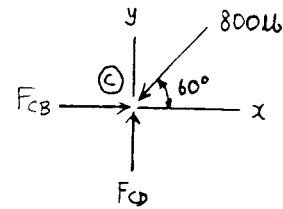

Joint *B* :

$$\rightarrow \Sigma F_x = 0; \quad \frac{3}{5} F_{BD} - 400 = 0$$

$$F_{BD} = 666.7 = 667 \text{ lb (T)} \quad \text{Ans}$$

$$+ \uparrow \Sigma F_y = 0; \quad F_{BA} - \frac{4}{5}(666.7) - 600 = 0$$

$$F_{BA} = 1133 \text{ lb} = 1.13 \text{ kip (C)} \quad \text{Ans}$$

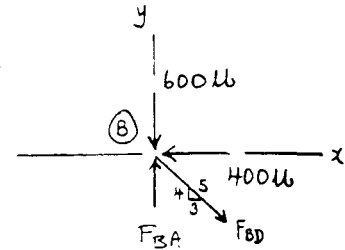

Member *AB* is a two-force member and exerts only a vertical force along *AB* at *A*.

6-19. Determine the force in each member of the truss and state if the members are in tension or compression. *Hint:* The resultant force at the pin E acts along member ED . Why?

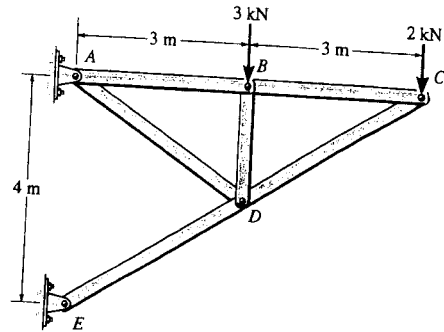

Joint C :

$$+\uparrow \Sigma F_y = 0; \quad \frac{2}{\sqrt{13}} F_{CD} - 2 = 0$$

$$F_{CD} = 3.606 = 3.61 \text{ kN (C)}$$

Ans

$$+\rightarrow \Sigma F_x = 0; \quad -F_{CB} + 3.606\left(\frac{3}{\sqrt{13}}\right) = 0$$

$$F_{CB} = 3 \text{ kN (T)}$$

Ans

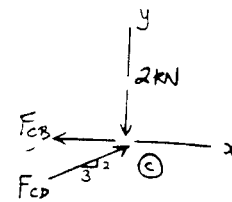

Joint B :

$$+\rightarrow \Sigma F_x = 0; \quad F_{BA} = 3 \text{ kN (T)} \quad \text{Ans}$$

$$+\uparrow \Sigma F_y = 0; \quad F_{BD} = 3 \text{ kN (C)} \quad \text{Ans}$$

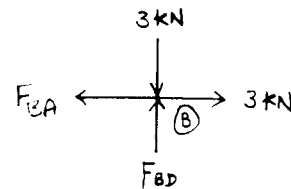

Joint D :

$$+\rightarrow \Sigma F_x = 0; \quad \frac{3}{\sqrt{13}} F_{DE} - \frac{3}{\sqrt{13}} (3.606) + \frac{3}{\sqrt{13}} F_{DA} = 0$$

$$+\uparrow \Sigma F_y = 0; \quad \frac{2}{\sqrt{13}} (F_{DE}) - \frac{2}{\sqrt{13}} (F_{DA}) - \frac{2}{\sqrt{13}} (3.606) - 3 = 0$$

$$F_{DA} = 2.70 \text{ kN (T)} \quad \text{Ans}$$

$$F_{DE} = 6.31 \text{ kN (C)} \quad \text{Ans}$$

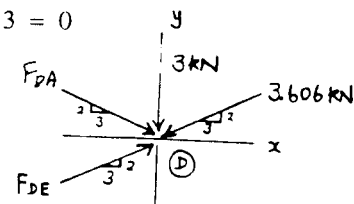

*6-20. Each member of the truss is uniform and has a mass of 8 kg/m. Remove the external loads of 3 kN and 2 kN and determine the approximate force in each member due to the weight of the truss. State if the members are in tension or compression. Solve the problem by *assuming* the weight of each member can be represented as a vertical force, half of which is applied at each end of the member.

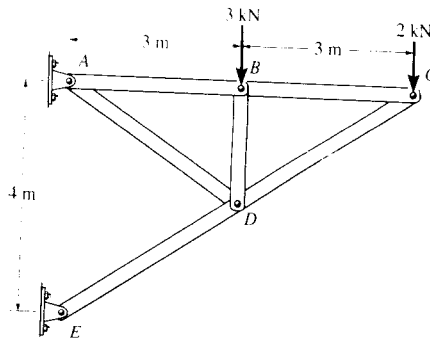

Joint C :

$$+\uparrow \Sigma F_y = 0; \quad \frac{2}{\sqrt{13}} F_{CD} - 259.2 = 0$$

$$F_{CD} = 467.3 = 467 \text{ N (C)}$$

Ans

$$\rightarrow \Sigma F_x = 0; \quad -F_{CB} + 467.3 \left(\frac{3}{\sqrt{13}} \right) = 0$$

$$F_{CB} = 388.8 = 389 \text{ N (T)}$$

Ans

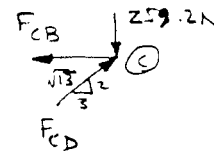
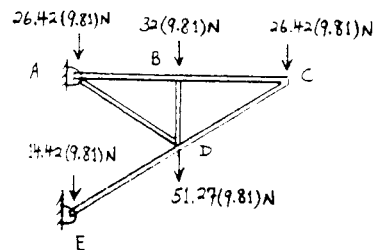

Joint B :

$$\rightarrow \Sigma F_x = 0; \quad F_{BA} = 388.8 = 389 \text{ N (T)}$$

Ans

$$+\uparrow \Sigma F_y = 0; \quad F_{BD} = 313.9 = 314 \text{ N (C)}$$

Ans

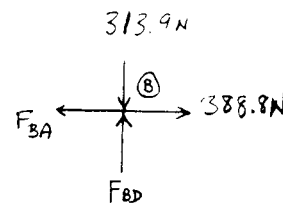

Joint D :

$$\rightarrow \Sigma F_x = 0; \quad \frac{3}{\sqrt{13}} F_{DE} - \frac{3}{\sqrt{13}} (467.3) - \frac{3}{\sqrt{13}} F_{DA} = 0$$

$$+\uparrow \Sigma F_y = 0; \quad \frac{2}{\sqrt{13}} (F_{DE}) + \frac{2}{\sqrt{13}} (F_{DA}) - \frac{2}{\sqrt{13}} (467.3) - 313.9 - 503.0 = 0$$

$$F_{DE} = 1203 = 1.20 \text{ kN (C)}$$

Ans

$$F_{DA} = 736 \text{ N (T)}$$

Ans

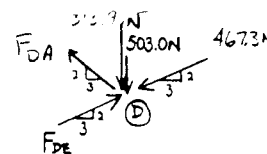

6-21. Determine the force in each member of the truss in terms of the external loading and state if the members are in tension or compression.

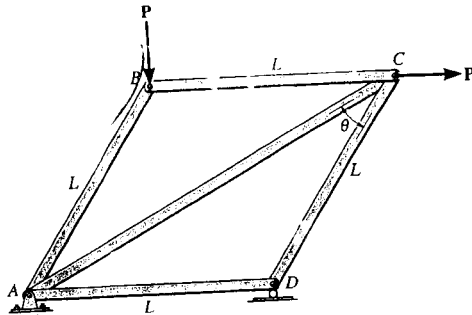

Joint B :

$$+\uparrow \Sigma F_y = 0; \quad F_{BA} \sin 2\theta - P = 0$$

$$F_{BA} = P \csc 2\theta \quad (\text{C}) \quad \text{Ans}$$

$$+\rightarrow \Sigma F_x = 0; \quad P \csc 2\theta (\cos 2\theta) - F_{BC} = 0$$

$$F_{BC} = P \cot 2\theta \quad (\text{C}) \quad \text{Ans}$$

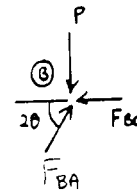

Joint C :

$$+\rightarrow \Sigma F_x = 0; \quad P \cot 2\theta + P + F_{CD} \cos 2\theta - F_{CA} \cos \theta = 0$$

$$+\uparrow \Sigma F_y = 0; \quad F_{CD} \sin 2\theta - F_{CA} \sin \theta = 0$$

$$F_{CA} = \frac{\cot 2\theta + 1}{\cos \theta - \sin \theta \cot 2\theta} P$$

$$F_{CA} = (\cot \theta \cos \theta - \sin \theta + 2 \cos \theta) P \quad (\text{T}) \quad \text{Ans}$$

$$F_{CD} = (\cot 2\theta + 1) P \quad (\text{C})$$

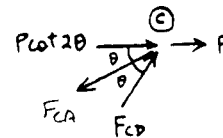

Joint D :

$$+\rightarrow \Sigma F_x = 0; \quad F_{DA} - (\cot 2\theta + 1)(\cos 2\theta) P = 0$$

$$F_{DA} = (\cot 2\theta + 1)(\cos 2\theta) P \quad (\text{C})$$

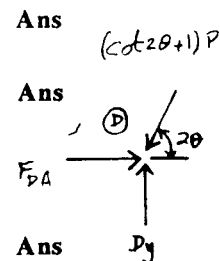

6-22. The maximum allowable tensile force in the members of the truss is $(F_t)_{max} = 2 \text{ kN}$, and the maximum allowable compressive force is $(F_c)_{max} = 1.2 \text{ kN}$. Determine the maximum magnitude P of the two loads that can be applied to the truss. Take $L = 2 \text{ m}$ and $\theta = 30^\circ$.

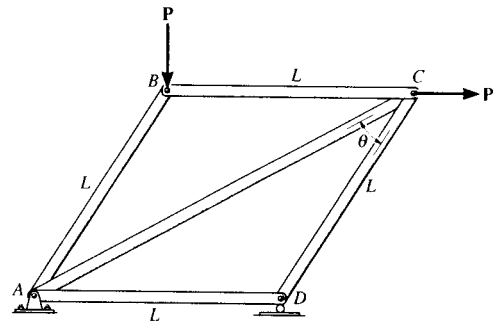

$$(T_t)_{max} = 2 \text{ kN}$$

$$(F_c)_{max} = 1.2 \text{ kN}$$

Joint B :

$$+\uparrow \Sigma F_y = 0; \quad F_{BA} \cos 30^\circ - P = 0$$

$$F_{BA} = \frac{P}{\cos 30^\circ} = 1.1547 P (C)$$

$$\rightarrow \Sigma F_x = 0; \quad F_{AB} \sin 30^\circ - F_{BC} = 0$$

$$F_{BC} = P \tan 30^\circ = 0.57735 P (C)$$

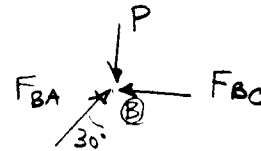

Joint C :

$$+\uparrow \Sigma F_y = 0; \quad -F_{CA} \cos 30^\circ + F_{CD} \sin 60^\circ = 0$$

$$F_{CA} = F_{CD} \left(\frac{\sin 60^\circ}{\sin 30^\circ} \right) = 1.732 F_{CD}$$

$$\rightarrow \Sigma F_x = 0; \quad P \tan 30^\circ + P + F_{CD} \cos 60^\circ - F_{CA} \cos 30^\circ = 0$$

$$F_{CD} = \left(\frac{\tan 30^\circ + 1}{\sqrt{3} \cos 30^\circ - \cos 60^\circ} \right) P = 1.577 P (C)$$

$$F_{CA} = 2.732 P (T)$$

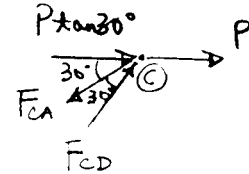

Joint D :

$$\rightarrow \Sigma F_x = 0; \quad F_{DA} - 1.577 P \sin 30^\circ = 0$$

$$F_{DA} = 0.7887 P (C)$$

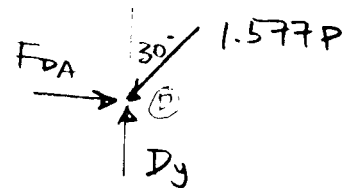

1) Assume $F_{CA} = 2 \text{ kN} = 2.732 P$

$$P = 732.06 \text{ N}$$

$$F_{CD} = 1.577(732.06) = 1154.5 \text{ N} < (F_c)_{max} = 1200 \text{ N} \quad (\text{O.K.})$$

Thus, $P_{max} = 732 \text{ N} \quad \text{Ans}$

6-23. Determine the force in each member of the truss and state if the members are in tension or compression.

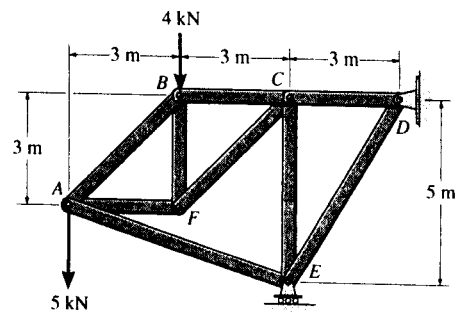

Support Reactions :

$$(+\Sigma M_D = 0; \quad 4(6) + 5(9) - E_y(3) = 0 \quad E_y = 23.0 \text{ kN}$$

$$+\uparrow \Sigma F_y = 0; \quad 23.0 - 4 - 5 - D_y = 0 \quad D_y = 14.0 \text{ kN}$$

$$\rightarrow \Sigma F_x = 0 \quad D_x = 0$$

Method of Joints :

Joint D

$$+\uparrow \Sigma F_y = 0; \quad F_{DE} \left(\frac{5}{\sqrt{34}} \right) - 14.0 = 0$$

$$F_{DE} = 16.33 \text{ kN (C)} = 16.3 \text{ kN (C)} \quad \text{Ans}$$

$$\rightarrow \Sigma F_x = 0; \quad 16.33 \left(\frac{3}{\sqrt{34}} \right) - F_{DC} = 0$$

$$F_{DC} = 8.40 \text{ kN (T)} \quad \text{Ans}$$

Joint E

$$\rightarrow \Sigma F_x = 0; \quad F_{EA} \left(\frac{3}{\sqrt{10}} \right) - 16.33 \left(\frac{3}{\sqrt{34}} \right) = 0$$

$$F_{EA} = 8.854 \text{ kN (C)} = 8.85 \text{ kN (C)} \quad \text{Ans}$$

$$+\uparrow \Sigma F_y = 0; \quad 23.0 - 16.33 \left(\frac{5}{\sqrt{34}} \right) - 8.854 \left(\frac{1}{\sqrt{10}} \right) - F_{EC} = 0$$

$$F_{EC} = 6.20 \text{ kN (C)} \quad \text{Ans}$$

Joint C

$$+\uparrow \Sigma F_y = 0; \quad 6.20 - F_{CF} \sin 45^\circ = 0$$

$$F_{CF} = 8.768 \text{ kN (T)} = 8.77 \text{ kN (T)} \quad \text{Ans}$$

$$\rightarrow \Sigma F_x = 0; \quad 8.40 - 8.768 \cos 45^\circ - F_{CB} = 0$$

$$F_{CB} = 2.20 \text{ kN (T)} \quad \text{Ans}$$

Joint B

$$\rightarrow \Sigma F_x = 0; \quad 2.20 - F_{BA} \cos 45^\circ = 0$$

$$F_{BA} = 3.111 \text{ kN (T)} = 3.11 \text{ kN (T)} \quad \text{Ans}$$

$$+\uparrow \Sigma F_y = 0; \quad F_{BF} - 4 - 3.111 \sin 45^\circ = 0$$

$$F_{BF} = 6.20 \text{ kN (C)} \quad \text{Ans}$$

Joint F

$$+\uparrow \Sigma F_y = 0; \quad 8.768 \sin 45^\circ - 6.20 = 0 \quad (\text{Check!})$$

$$\rightarrow \Sigma F_x = 0; \quad 8.768 \cos 45^\circ - F_{FA} = 0$$

$$F_{FA} = 6.20 \text{ kN (T)} \quad \text{Ans}$$

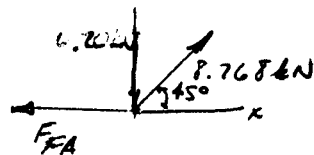
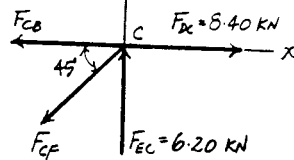
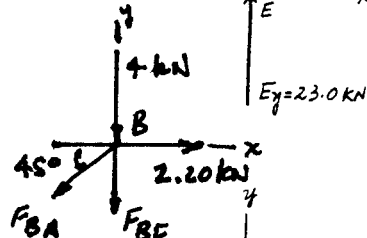
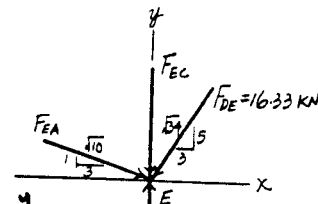
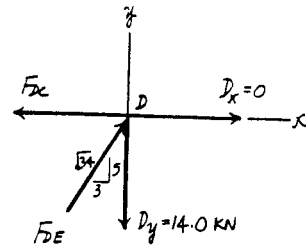
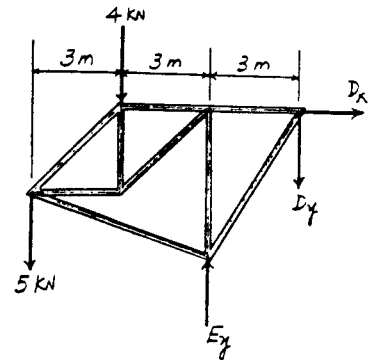

*6-24. Determine the force in each member of the double scissors truss in terms of the load P and state if the members are in tension or compression.

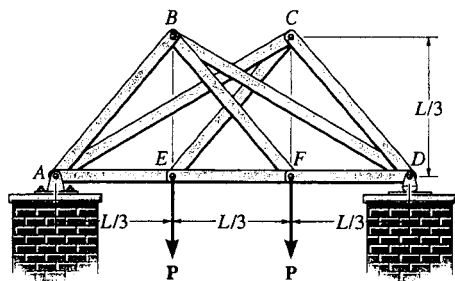

Prob. 6-24

$$\uparrow + \Sigma M_A = 0; \quad P\left(\frac{L}{3}\right) + P\left(\frac{2L}{3}\right) - (D_y)(L) = 0$$

$$D_y = P$$

$$+\uparrow \Sigma F_y = 0; \quad A_y = P$$

Joint F:

$$+\uparrow \Sigma F_y = 0; \quad F_{FB}\left(\frac{1}{\sqrt{2}}\right) - P = 0$$

$$F_{FB} = \sqrt{2}P = 1.41P \text{ (T)}$$

$$\rightarrow \Sigma F_x = 0; \quad F_{FD} - F_{FE} - F_{FB}\left(\frac{1}{\sqrt{2}}\right) = 0$$

$$F_{FD} - F_{FE} = P \quad (1)$$

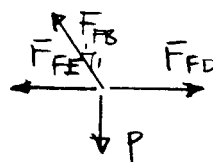
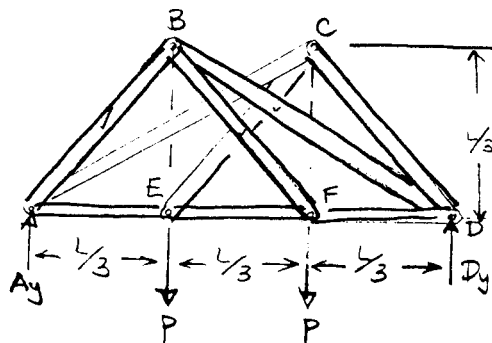

Con'd

6-24 cont'd

Joint E :

$$+\uparrow \Sigma F_y = 0; \quad F_{EC} \left(\frac{1}{\sqrt{2}} \right) - P = 0$$

$$F_{EC} = \sqrt{2}P = 1.41P (T)$$

$$\rightarrow \Sigma F_x = 0; \quad F_{EF} - F_{EA} + 1.41P \left(\frac{1}{\sqrt{2}} \right) = 0$$

$$F_{EA} - F_{EF} = P \quad (2)$$

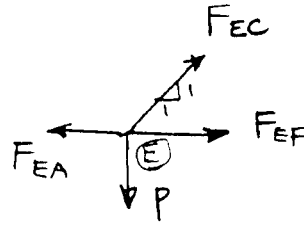

Joint B :

$$+\uparrow \Sigma F_y = 0; \quad F_{BA} \left(\frac{1}{\sqrt{2}} \right) + F_{BD} \left(\frac{1}{\sqrt{5}} \right) - (\sqrt{2}P) \left(\frac{1}{\sqrt{2}} \right) = 0$$

$$\frac{1}{\sqrt{2}} F_{BA} + \frac{1}{\sqrt{5}} F_{BD} = P$$

$$\rightarrow \Sigma F_x = 0; \quad F_{BA} \left(\frac{1}{\sqrt{2}} \right) + \sqrt{2}P \left(\frac{1}{\sqrt{2}} \right) - F_{BD} \left(\frac{2}{\sqrt{5}} \right) = 0$$

$$\frac{1}{\sqrt{2}} F_{BA} - \frac{2}{\sqrt{5}} F_{BD} = -P$$

$$F_{BD} = \frac{2\sqrt{5}}{3}P = 1.4907P = 1.49P (C)$$

$$F_{BA} = \frac{\sqrt{2}}{3}P = 0.4714P = 0.471P (C)$$

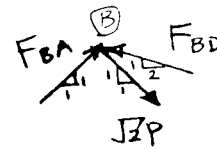

Joint C :

$$+\uparrow \Sigma F_y = 0; \quad F_{CA} \left(\frac{1}{\sqrt{5}} \right) + F_{CD} \left(\frac{1}{\sqrt{2}} \right) - (\sqrt{2}P) \left(\frac{1}{\sqrt{2}} \right) = 0$$

$$\frac{1}{\sqrt{5}} F_{CA} + \frac{1}{\sqrt{2}} F_{CD} = P$$

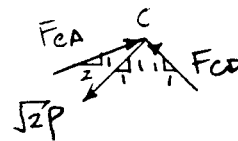

Con'd

6-24 cont'd

$$\rightarrow \Sigma F_x = 0; \quad F_{CA} \left(\frac{2}{\sqrt{5}} \right) - \sqrt{2} P \left(\frac{1}{\sqrt{2}} \right) - F_{CD} \left(\frac{1}{\sqrt{2}} \right) = 0$$

$$\frac{2}{\sqrt{5}} F_{CA} - \frac{1}{\sqrt{2}} F_{CD} = P$$

$$F_{CA} = \frac{2\sqrt{5}}{3} P = 1.4907P = 1.49P \text{ (C)}$$

$$F_{CD} = \frac{\sqrt{2}}{3} P = 0.4714P = 0.471P \text{ (C)}$$

Joint A :

$$\rightarrow \Sigma F_x = 0; \quad F_{AE} - \frac{\sqrt{2}}{3} P \left(\frac{1}{\sqrt{2}} \right) - \frac{2\sqrt{5}}{3} P \left(\frac{2}{\sqrt{5}} \right) = 0$$

$$F_{AE} = \frac{5}{3} P = 1.67 P \text{ (T)}$$

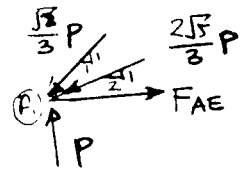

From Eqs. (1) and (2) :

$$F_{EF} = 0.667 P \text{ (T)} \quad \text{Ans}$$

$$F_{FD} = 1.67 P \text{ (T)} \quad \text{Ans}$$

$$F_{AB} = 0.471 P \text{ (C)} \quad \text{Ans}$$

$$F_{AE} = 1.67 P \text{ (T)} \quad \text{Ans}$$

$$F_{AC} = 1.49P \text{ (C)} \quad \text{Ans}$$

$$F_{BF} = 1.41 P \text{ (T)} \quad \text{Ans}$$

$$F_{BD} = 1.49 P \text{ (C)} \quad \text{Ans}$$

$$F_{EC} = 1.41 P \text{ (T)} \quad \text{Ans}$$

$$F_{CD} = 0.471 P \text{ (C)} \quad \text{Ans}$$

6-25. Determine the force in each member of the truss and state if the members are in tension or compression. *Hint:* The vertical component of force at C must equal zero. Why?

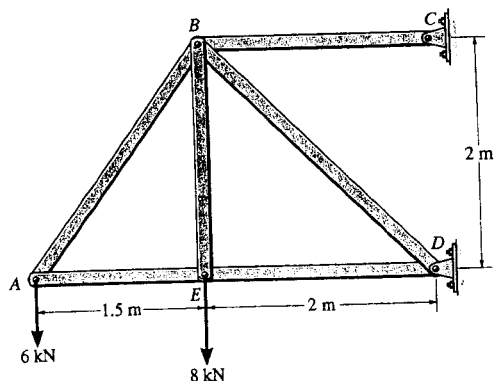

Joint A :

$$+\uparrow \Sigma F_y = 0; \quad \frac{4}{5}F_{AB} - 6 = 0$$

$$F_{AB} = 7.5 \text{ kN (T)}$$

Ans

$$+\rightarrow \Sigma F_x = 0; \quad -F_{AE} + 7.5\left(\frac{3}{5}\right) = 0$$

$$F_{AE} = 4.5 \text{ kN (C)}$$

Ans

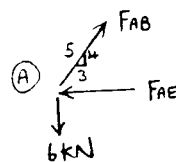

Joint E :

$$+\rightarrow \Sigma F_x = 0; \quad F_{ED} = 4.5 \text{ kN (C)}$$

Ans

$$+\uparrow \Sigma F_y = 0; \quad F_{EB} = 8 \text{ kN (T)}$$

Ans

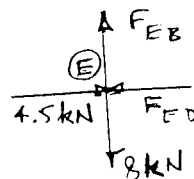

Joint B :

$$+\uparrow \Sigma F_y = 0; \quad \frac{1}{\sqrt{2}}(F_{BD}) - 8 - \frac{4}{5}(7.5) = 0$$

$$F_{BD} = 19.8 \text{ kN (C)}$$

Ans

$$+\rightarrow \Sigma F_x = 0; \quad F_{BC} - \frac{3}{5}(7.5) - \frac{1}{\sqrt{2}}(19.8) = 0$$

$$F_{BC} = 18.5 \text{ kN (T)}$$

Ans

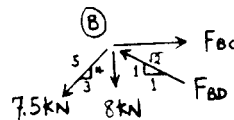

C_y is zero because BC is a two-force member.

6-26. Each member of the truss is uniform and has a mass of 8 kg/m. Remove the external loads of 6 kN and 8 kN and determine the approximate force in each member due to the weight of the truss. State if the members are in tension or compression. Solve the problem by *assuming* the weight of each member can be represented as a vertical force, half of which is applied at each end of the member.

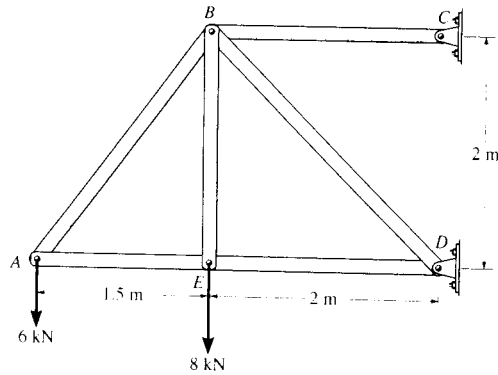

Joint A :

$$+\uparrow \Sigma F_y = 0; \quad \frac{4}{5}F_{AB} - 157.0 = 0$$

$$F_{AB} = 196.2 = 196 \text{ N (T)}$$

Ans

$$+\rightarrow \Sigma F_x = 0; \quad -F_{AE} + 196.2\left(\frac{3}{5}\right) = 0$$

$$F_{AE} = 117.7 = 118 \text{ N (C)}$$

Ans

Joint E :

$$+\rightarrow \Sigma F_x = 0; \quad F_{ED} = 117.7 = 118 \text{ N (C)}$$

Ans

$$+\uparrow \Sigma F_y = 0; \quad F_{EB} = 215.8 = 216 \text{ N (T)}$$

Ans

Joint B :

$$+\uparrow \Sigma F_y = 0; \quad \frac{1}{\sqrt{2}}(F_{BD}) - 366.0 - 215.8 - \frac{4}{5}(196.2) = 0$$

$$F_{BD} = 1045 = 1.04 \text{ kN (C)}$$

Ans

$$+\rightarrow \Sigma F_x = 0; \quad F_{BC} - \frac{3}{5}(196.2) - \frac{1}{\sqrt{2}}(1045) = 0$$

$$F_{BC} = 857 \text{ N (T)}$$

Ans

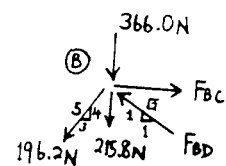
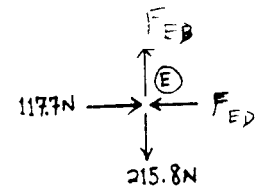
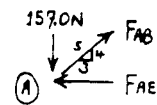
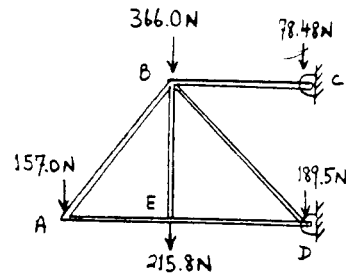

6-27. Determine the force in each member of the truss in terms of the load P , and indicate whether the members are in tension or compression.

Support Reactions :

$$(+\Sigma M_E = 0; \quad P(2d) - A_y \left(\frac{3}{2}d\right) = 0 \quad A_y = \frac{4}{3}P$$

$$+\uparrow \Sigma F_y = 0; \quad \frac{4}{3}P - E_y = 0 \quad E_y = \frac{4}{3}P$$

$$\rightarrow \Sigma F_x = 0 \quad E_x - P = 0 \quad E_x = P$$

Method of Joints : By inspection of joint C, members CB and CD are zero force member. Hence

$$F_{CB} = F_{CD} = 0 \quad \text{Ans}$$

Joint A

$$+\uparrow \Sigma F_y = 0; \quad F_{AB} \left(\frac{1}{\sqrt{3.25}}\right) - \frac{4}{3}P = 0$$

$$F_{AB} = 2.404P \text{ (C)} = 2.40P \text{ (C)} \quad \text{Ans}$$

$$\rightarrow \Sigma F_x = 0; \quad F_{AF} - 2.404P \left(\frac{1.5}{\sqrt{3.25}}\right) = 0$$

$$F_{AF} = 2.00P \text{ (T)} \quad \text{Ans}$$

Joint B

$$\rightarrow \Sigma F_x = 0; \quad 2.404P \left(\frac{1.5}{\sqrt{3.25}}\right) - P$$

$$- F_{BF} \left(\frac{0.5}{\sqrt{1.25}}\right) - F_{BD} \left(\frac{0.5}{\sqrt{1.25}}\right) = 0$$

$$1.00P - 0.4472F_{BF} - 0.4472F_{BD} = 0 \quad [1]$$

$$+\uparrow \Sigma F_y = 0; \quad 2.404P \left(\frac{1}{\sqrt{3.25}}\right) + F_{BD} \left(\frac{1}{\sqrt{1.25}}\right) - F_{BF} \left(\frac{1}{\sqrt{1.25}}\right) = 0$$

$$1.333P + 0.8944F_{BD} - 0.8944F_{BF} = 0 \quad [2]$$

Solving Eqs. [1] and [2] yield,

$$F_{BF} = 1.863P \text{ (T)} = 1.86P \text{ (T)} \quad \text{Ans}$$

$$F_{BD} = 0.3727P \text{ (C)} = 0.373P \text{ (C)} \quad \text{Ans}$$

Joint F

$$+\uparrow \Sigma F_y = 0; \quad 1.863P \left(\frac{1}{\sqrt{1.25}}\right) - F_{FE} \left(\frac{1}{\sqrt{1.25}}\right) = 0$$

$$F_{FE} = 1.863P \text{ (T)} = 1.86P \text{ (T)} \quad \text{Ans}$$

$$\rightarrow \Sigma F_x = 0; \quad F_{FD} + 2 \left[1.863P \left(\frac{0.5}{\sqrt{1.25}}\right) \right] - 2.00P = 0$$

$$F_{FD} = 0.3333P \text{ (T)} = 0.333P \text{ (T)} \quad \text{Ans}$$

Joint D

$$+\uparrow \Sigma F_y = 0; \quad F_{DE} \left(\frac{1}{\sqrt{1.25}}\right) - 0.3727P \left(\frac{1}{\sqrt{1.25}}\right) = 0$$

$$F_{DE} = 0.3727P \text{ (C)} = 0.373P \text{ (C)} \quad \text{Ans}$$

$$\rightarrow \Sigma F_x = 0; \quad 2 \left[0.3727P \left(\frac{0.5}{\sqrt{1.25}}\right) \right] - 0.3333P = 0 \text{ (Check!)}$$

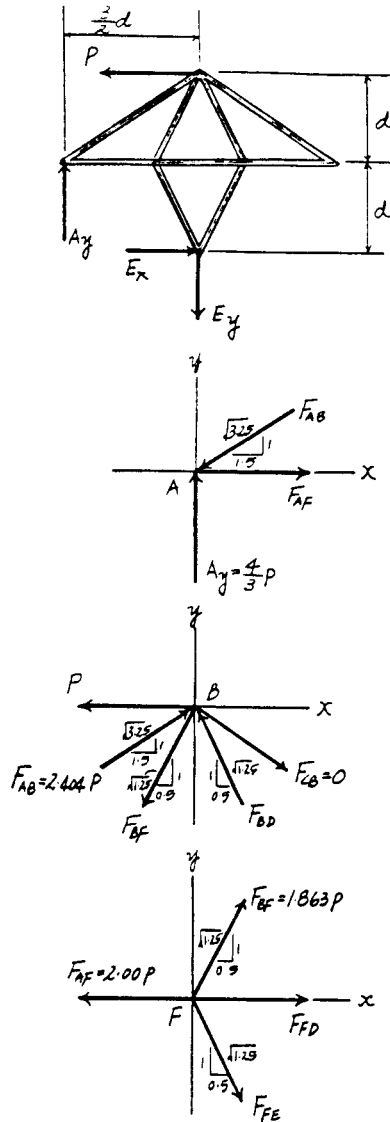

*6-28. If the maximum force that any member can support is 4 kN in tension and 3 kN in compression, determine the maximum force P that can be supported at point B . Take $d = 1$ m.

Support Reactions :

$$+\circlearrowleft \Sigma M_E = 0; \quad P(2d) - A_y \left(\frac{3}{2}d \right) = 0 \quad A_y = \frac{4}{3}P$$

$$+\uparrow \Sigma F_y = 0; \quad \frac{4}{3}P - E_y = 0 \quad E_y = \frac{4}{3}P$$

$$\rightarrow \Sigma F_x = 0 \quad E_x - P = 0 \quad E_x = P$$

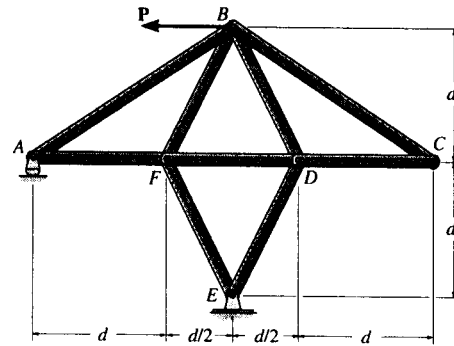

Method of Joints : By inspection of joint C , members CB and CD are zero force member. Hence

$$F_{CB} = F_{CD} = 0$$

Joint A

$$+\uparrow \Sigma F_y = 0; \quad F_{AB} \left(\frac{1}{\sqrt{3.25}} \right) - \frac{4}{3}P = 0 \quad F_{AB} = 2.404P \text{ (C)}$$

$$\rightarrow \Sigma F_x = 0; \quad F_{AF} - 2.404P \left(\frac{1.5}{\sqrt{3.25}} \right) = 0 \quad F_{AF} = 2.00P \text{ (T)}$$

Joint B

$$\rightarrow \Sigma F_x = 0; \quad 2.404P \left(\frac{1.5}{\sqrt{3.25}} \right) - P - F_{BF} \left(\frac{0.5}{\sqrt{1.25}} \right) - F_{BD} \left(\frac{0.5}{\sqrt{1.25}} \right) = 0$$

$$1.00P - 0.4472F_{BF} - 0.4472F_{BD} = 0 \quad [1]$$

$$+\uparrow \Sigma F_y = 0; \quad 2.404P \left(\frac{1}{\sqrt{3.25}} \right) + F_{BD} \left(\frac{1}{\sqrt{1.25}} \right) - F_{BF} \left(\frac{1}{\sqrt{1.25}} \right) = 0$$

$$1.333P + 0.8944F_{BD} - 0.8944F_{BF} = 0 \quad [2]$$

Solving Eqs. [1] and [2] yield,

$$F_{BF} = 1.863P \text{ (T)} \quad F_{BD} = 0.3727P \text{ (C)}$$

Joint F

$$+\uparrow \Sigma F_y = 0; \quad 1.863P \left(\frac{1}{\sqrt{1.25}} \right) - F_{FE} \left(\frac{1}{\sqrt{1.25}} \right) = 0$$

$$F_{FE} = 1.863P \text{ (T)}$$

$$\rightarrow \Sigma F_x = 0; \quad F_{FD} + 2 \left[1.863P \left(\frac{0.5}{\sqrt{1.25}} \right) \right] - 2.00P = 0$$

$$F_{FD} = 0.3333P \text{ (T)}$$

Joint D

$$+\uparrow \Sigma F_y = 0; \quad F_{DE} \left(\frac{1}{\sqrt{1.25}} \right) - 0.3727P \left(\frac{1}{\sqrt{1.25}} \right) = 0$$

$$F_{DE} = 0.3727P \text{ (C)}$$

$$\rightarrow \Sigma F_x = 0; \quad 2 \left[0.3727P \left(\frac{0.5}{\sqrt{1.25}} \right) \right] - 0.3333P = 0 \text{ (Check!)}$$

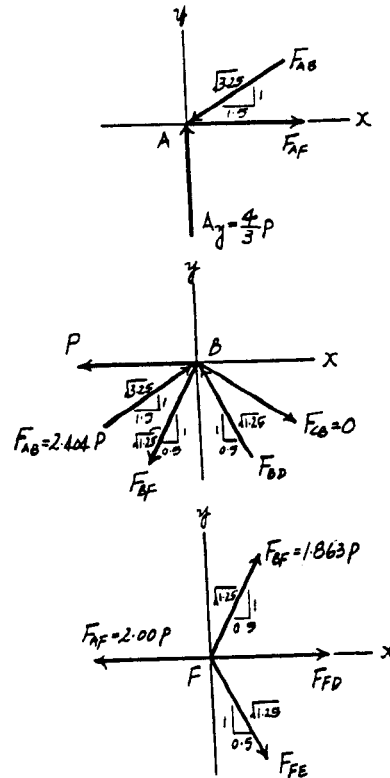

From the above analysis, the maximum compression and tension in the truss members are $2.404P$ and $2.00P$, respectively. For this case, compression controls which requires

$$2.404P = 3$$

$$P = 1.25 \text{ kN}$$

#6-29. The two-member truss is subjected to the force of 300 lb. Determine the range of θ for application of the load so that the force in either member does not exceed 400 lb (T) or 200 lb (C).

Joint A:

$$\rightarrow \Sigma F_x = 0: \quad 300 \cos \theta + F_{AC} + F_{AB} \left(\frac{4}{5}\right) = 0$$

$$+\uparrow \Sigma F_y = 0: \quad -300 \sin \theta + F_{AB} \left(\frac{3}{5}\right) = 0$$

Thus,

$$F_{AB} = 500 \sin \theta$$

$$F_{AC} = -300 \cos \theta - 400 \sin \theta$$

For AB require:

$$-200 \leq 500 \sin \theta \leq 400$$

$$-2 \leq 5 \sin \theta \leq 4 \quad (1)$$

For AC require:

$$-200 \leq -300 \cos \theta - 400 \sin \theta \leq 400$$

$$-4 \leq 3 \cos \theta + 4 \sin \theta \leq 2 \quad (2)$$

Solving Eqs. (1) and (2) simultaneously,

$$127^\circ \leq \theta \leq 196^\circ \quad \text{Ans}$$

$$336^\circ \leq \theta \leq 347^\circ \quad \text{Ans}$$

A possible hand solution:

$$\theta_2 = \theta_1 + \tan^{-1} \left(\frac{3}{4}\right) = \theta_1 + 36.870$$

Then

$$F_{AB} = 500 \sin \theta_1$$

$$F_{AC} = -300 \cos (\theta_2 - 36.870^\circ) - 400 \sin (\theta_2 - 36.870^\circ)$$

$$= -300 [\cos \theta_2 \cos 36.870^\circ + \sin \theta_2 \sin 36.870^\circ]$$

$$-400 [\sin \theta_2 \cos 36.870^\circ - \cos \theta_2 \sin 36.870^\circ]$$

$$= -240 \cos \theta_2 - 180 \sin \theta_2 - 320 \sin \theta_2 + 240 \cos \theta_2$$

$$= -500 \sin \theta_2$$

Thus, we require

$$-2 \leq 5 \sin \theta_1 \leq 4 \quad \text{or} \quad -0.4 \leq \sin \theta_1 \leq 0.8 \quad (1)$$

$$-4 \leq 5 \sin \theta_2 \leq 2 \quad \text{or} \quad -0.8 \leq \sin \theta_2 \leq 0.4 \quad (2)$$

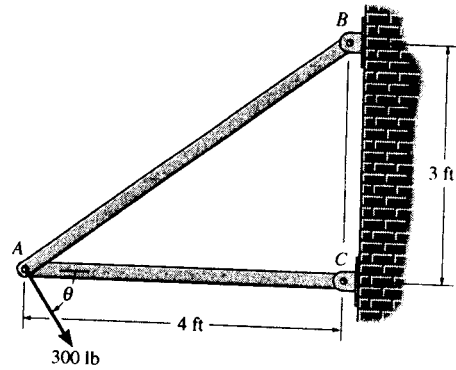
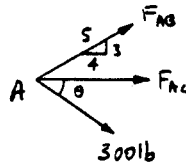

The range of values for Eqs. (1) and (2) are shown in the figures:

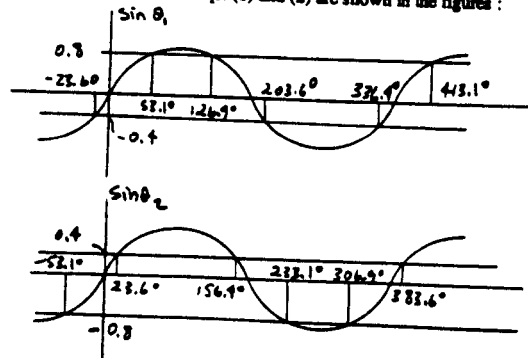

Since $\theta_1 = \theta_2 - 36.870^\circ$, the range of acceptable values for $\theta = \theta_1$ is

$$127^\circ \leq \theta \leq 196^\circ \quad \text{Ans}$$

$$336^\circ \leq \theta \leq 347^\circ \quad \text{Ans}$$

6-30. Determine the force in members BC , HC , and HG of the bridge truss, and indicate whether the members are in tension or compression.

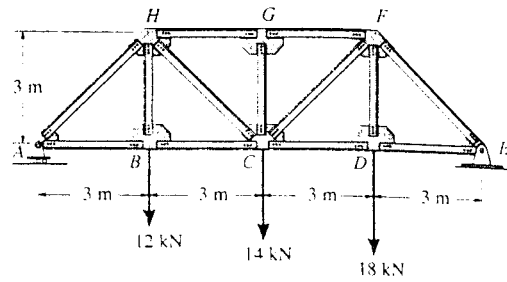

Support Reactions :

$$\left(+ \Sigma M_E = 0; \quad 18(3) + 14(6) + 12(9) - A_y(12) = 0 \quad A_y = 20.5 \text{ kN} \right.$$

Method of Sections :

$$\left(+ \Sigma M_C = 0; \quad F_{HG}(3) + 12(3) - 20.5(6) = 0 \right. \\ \left. F_{HG} = 29.0 \text{ kN (C)} \right.$$

Ans

$$\left(+ \Sigma M_H = 0; \quad F_{BC}(3) - 20.5(3) = 0 \right. \\ \left. F_{BC} = 20.5 \text{ kN (T)} \right.$$

Ans

$$\left(+ \uparrow \Sigma F_y = 0; \quad 20.5 - 12 - F_{HC} \sin 45^\circ = 0 \right. \\ \left. F_{HC} = 12.0 \text{ kN (T)} \right.$$

Ans

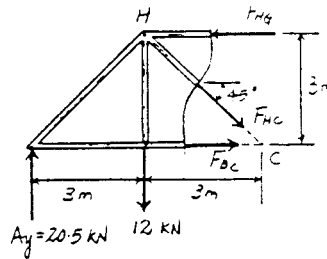
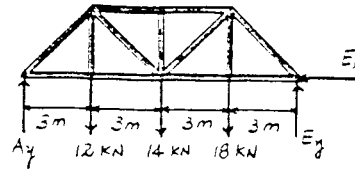

6-31. Determine the force in members GF , CF , and CD of the bridge truss, and indicate whether the members are in tension or compression.

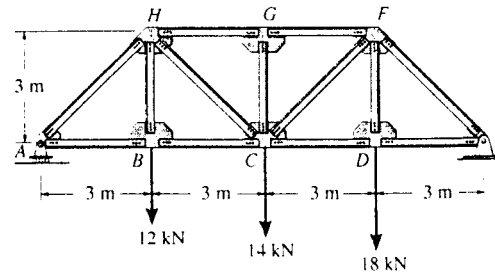

Support Reactions :

$$\left(+ \Sigma M_A = 0; \quad E_y(12) - 18(9) - 14(6) - 12(3) = 0 \quad E_y = 23.5 \text{ kN} \right.$$

$$\left(\rightarrow \Sigma F_x = 0; \quad E_x = 0 \right.$$

Method of Sections :

$$\left(+ \Sigma M_C = 0; \quad 23.5(6) - 18(3) - F_{GF}(3) = 0 \right. \\ \left. F_{GF} = 29.0 \text{ kN (C)} \right.$$

Ans

$$\left(+ \Sigma M_F = 0; \quad 23.5(3) - F_{CD}(3) = 0 \right. \\ \left. F_{CD} = 23.5 \text{ kN (T)} \right.$$

Ans

$$\left(+ \uparrow \Sigma F_y = 0; \quad 23.5 - 18 - F_{CF} \sin 45^\circ = 0 \right. \\ \left. F_{CF} = 7.78 \text{ kN (T)} \right.$$

Ans

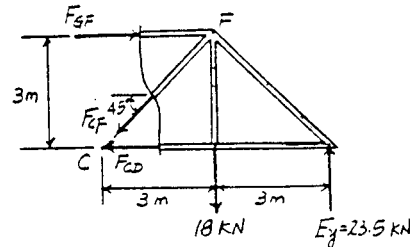

*6-32. Determine the force in members DE , DF , and GF of the cantilevered truss and state if the members are in tension or compression.

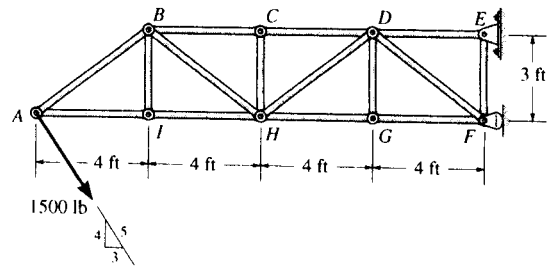

$$+\uparrow \Sigma F_y = 0; \quad \frac{3}{5} F_{DF} - \frac{4}{5} (1500) = 0$$

$$F_{DF} = 2000 \text{ lb} = 2.0 \text{ kip (C)} \quad \text{Ans}$$

$$\curvearrow + \Sigma M_D = 0; \quad \frac{4}{5} (1500) (12) + \frac{3}{5} (1500) (3) - F_{GF} (3) = 0$$

$$F_{GF} = 5700 \text{ lb} = 5.70 \text{ kip (C)} \quad \text{Ans}$$

$$\curvearrow + \Sigma M_F = 0; \quad \frac{4}{5} (1500) (16) - F_{DE} (3) = 0$$

$$F_{DE} = 6400 \text{ lb} = 6.40 \text{ kip (T)} \quad \text{Ans}$$

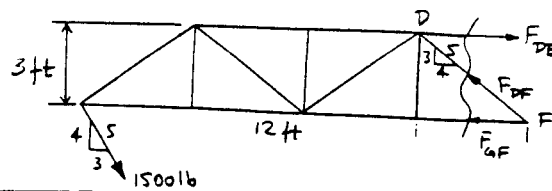

6-33. The roof truss supports the vertical loading shown. Determine the force in members BC , CK , and KJ and state if these members are in tension or compression.

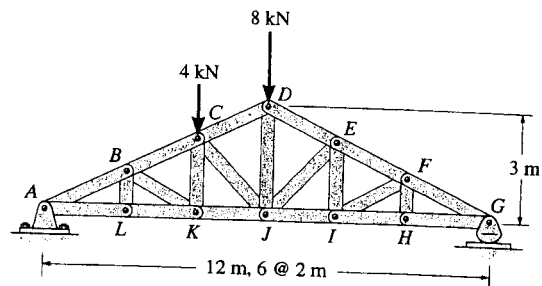

$$\rightarrow \Sigma F_x = 0; \quad A_x = 0$$

$$\curvearrow + \Sigma M_G = 0; \quad -A_y (12) + 4(8) + 8(6) = 0$$

$$A_y = 6.667 \text{ kN}$$

$$\curvearrow + \Sigma M_C = 0; \quad -6.667(4) + F_{KJ}(2) = 0$$

$$F_{KJ} = 13.3 \text{ kN (T)} \quad \text{Ans}$$

$$\curvearrow + \Sigma M_K = 0; \quad 6.667(4) - \frac{2}{\sqrt{5}} F_{BC}(2) = 0$$

$$F_{BC} = 14.907 = 14.9 \text{ kN (C)} \quad \text{Ans}$$

$$\curvearrow + \Sigma M_A = 0; \quad F_{CK} = 0 \quad \text{Ans}$$

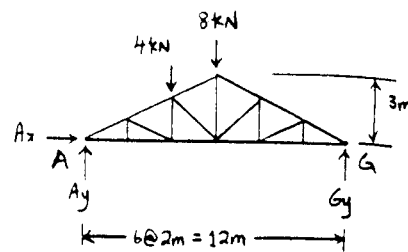

Ans

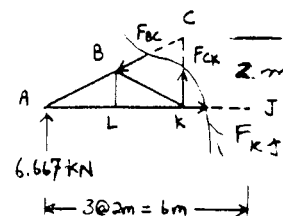

Ans

Ans

6-34. Determine the force in members CD , CJ , KJ , and DJ of the truss which serves to support the deck of a bridge. State if these members are in tension or compression.

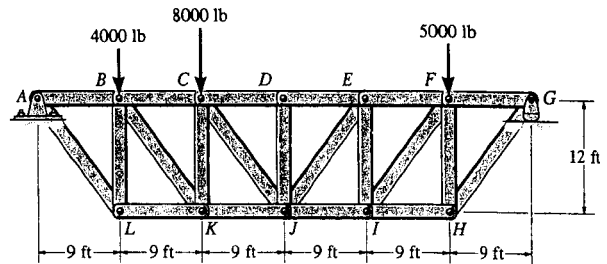

$$\curvearrowleft + \Sigma M_C = 0; \quad -9500(18) + 4000(9) + F_{KJ}(12) = 0$$

$$F_{KJ} = 11\,250 \text{ lb} = 11.2 \text{ kip (T)} \quad \text{Ans}$$

$$\curvearrowleft + \Sigma M_J = 0; \quad -9500(27) + 4000(18) + 8000(9) + F_{CD}(12) = 0$$

$$F_{CD} = 9375 \text{ lb} = 9.38 \text{ kip (C)} \quad \text{Ans}$$

$$\rightarrow \Sigma F_x = 0; \quad -9375 + 11\,250 - \frac{3}{5}F_{CJ} = 0$$

$$F_{CJ} = 3125 \text{ lb} = 3.12 \text{ kip (C)} \quad \text{Ans}$$

Joint D, $F_{DJ} = 0 \quad \text{Ans}$

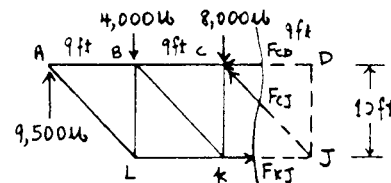
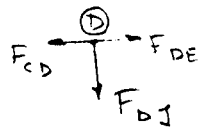

6-35. Determine the force in members EI and JI of the truss which serves to support the deck of a bridge. State if these members are in tension or compression.

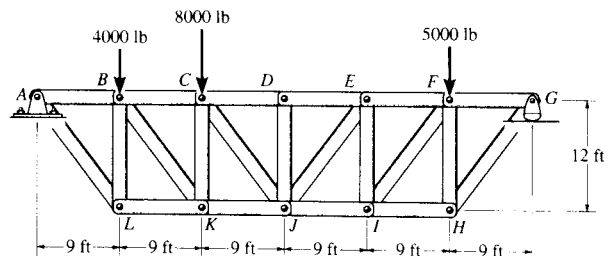

$$\curvearrowleft + \Sigma M_E = 0; \quad -5000(9) + 7500(18) - F_{JI}(12) = 0$$

$$F_{JI} = 7500 \text{ lb} = 7.50 \text{ kip (T)} \quad \text{Ans}$$

$$+ \uparrow \Sigma F_y = 0; \quad 7500 - 5000 - F_{EI} = 0$$

$$F_{EI} = 2500 \text{ lb} = 2.50 \text{ kip (C)} \quad \text{Ans}$$

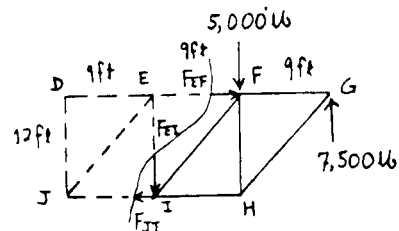

*6-36. Determine the force in members BC , CG , and GF of the Warren truss. Indicate if the members are in tension or compression.

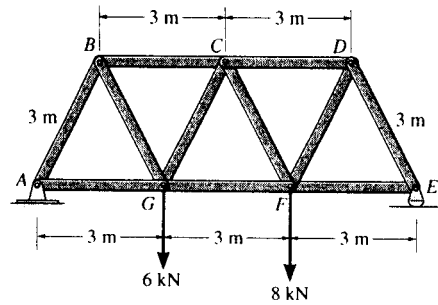

Support Reactions :

$$\left(+\Sigma M_E = 0; \quad 6(6) + 8(3) - A_y(9) = 0 \quad A_y = 6.667 \text{ kN} \right.$$

$$\rightarrow \Sigma F_x = 0; \quad A_x = 0$$

Method of Sections :

$$\left(+\Sigma M_C = 0; \quad F_{GF}(3\sin 60^\circ) + 6(1.5) - 6.667(4.5) = 0 \right.$$

$$F_{GF} = 8.08 \text{ kN (T)}$$

Ans

$$\left(+\Sigma M_G = 0; \quad F_{BC}(3\sin 60^\circ) - 6.667(3) = 0 \right.$$

$$F_{BC} = 7.70 \text{ kN (C)}$$

Ans

$$+ \uparrow \Sigma F_y = 0; \quad 6.667 - 6 - F_{CG}\sin 60^\circ = 0$$

$$F_{CG} = 0.770 \text{ kN (C)}$$

Ans

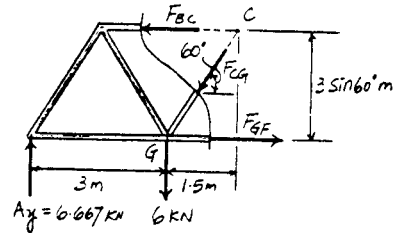
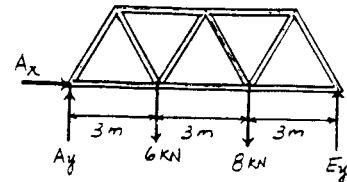

6-37. Determine the force in members CD , CF , and FG of the Warren truss. Indicate if the members are in tension or compression.

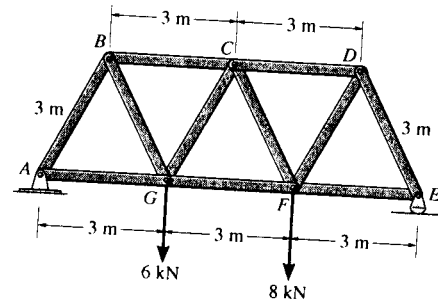

Support Reactions :

$$\left(+\Sigma M_A = 0; \quad E_y(9) - 8(6) - 6(3) = 0 \quad E_y = 7.333 \text{ kN} \right.$$

Method of Sections :

$$\left(+\Sigma M_C = 0; \quad 7.333(4.5) - 8(1.5) - F_{FG}(3\sin 60^\circ) = 0 \right.$$

$$F_{FG} = 8.08 \text{ kN (T)}$$

Ans

$$\left(+\Sigma M_F = 0; \quad 7.333(3) - F_{CD}(3\sin 60^\circ) = 0 \right.$$

$$F_{CD} = 8.47 \text{ kN (C)}$$

Ans

$$+ \uparrow \Sigma F_y = 0; \quad F_{CF}\sin 60^\circ + 7.333 - 8 = 0$$

$$F_{CF} = 0.770 \text{ kN (T)}$$

Ans

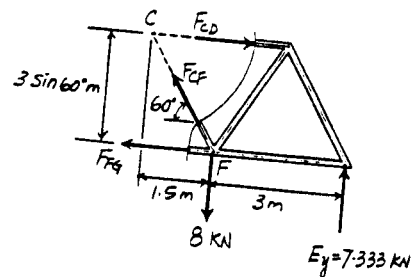

6-38. Determine the force developed in members GB and GF of the bridge truss and state if these members are in tension or compression.

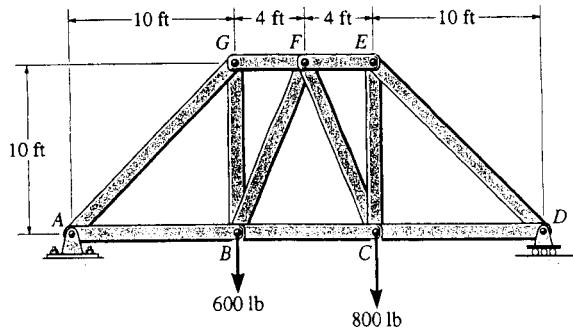

$$(+\Sigma M_A = 0; \quad -600(10) - 800(18) + D_y(28) = 0$$

$$D_y = 728.571 \text{ lb}$$

$$(\rightarrow \Sigma F_x = 0; \quad A_x = 0$$

$$(+\uparrow \Sigma F_y = 0; \quad A_y - 600 - 800 + 728.571 = 0$$

$$A_y = 671.429 \text{ lb}$$

$$(+\Sigma M_B = 0; \quad -671.429(10) + F_{GF}(10) = 0$$

$$F_{GF} = 671.429 \text{ lb} = 671 \text{ lb (C)}$$

$$(+\uparrow \Sigma F_y = 0; \quad 671.429 - F_{GB} = 0$$

$$F_{GB} = 671 \text{ lb (T)}$$

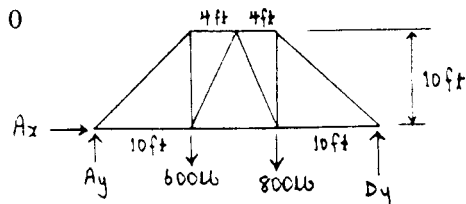

Ans

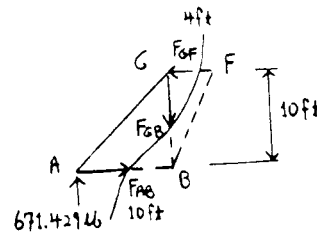

Ans

6-39. The truss supports the vertical load of 600 N. Determine the force in members BC , BG , and HG as the dimension L varies. Plot the results of F (ordinate with tension as positive) versus L (abscissa) for $0 \leq L \leq 3 \text{ m}$.

$$(+\uparrow \Sigma F_y = 0; \quad -600 - F_{BC} \sin \theta = 0$$

$$F_{BC} = -\frac{600}{\sin \theta}$$

$$\sin \theta = \frac{3}{\sqrt{L^2 + 9}}$$

$$F_{BC} = -200\sqrt{L^2 + 9}$$

$$(+\Sigma M_G = 0; \quad -F_{BC}(3) - 600(L) = 0$$

$$F_{BC} = -200L$$

$$(+\Sigma M_B = 0; \quad F_{HG}(3) - 600(2L) = 0$$

$$F_{HG} = 400L$$

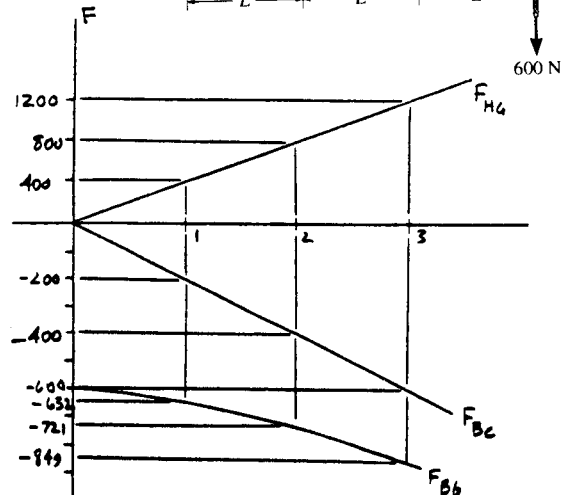
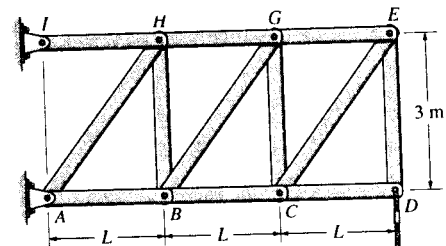
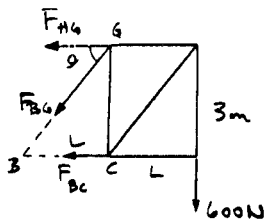

***6-40.** Determine the force in members IC and CG of the truss and state if these members are in tension or compression. Also, indicate all zero-force members.

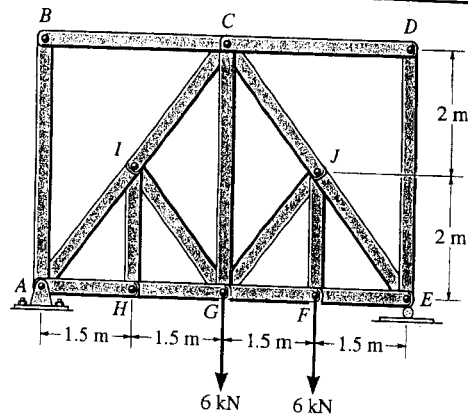

By inspection of joints B , D , H and I ,

AB , BC , CD , DE , HI , and GI are all zero-force members. **Ans**

$$+\Sigma M_G = 0; \quad -4.5(3) + F_{IC}\left(\frac{3}{5}\right)(4) = 0$$

$$F_{IC} = 5.62 \text{ kN (C)} \quad \text{Ans}$$

Joint C :

$$\rightarrow \Sigma F_x = 0; \quad F_{CI} = 5.625 \text{ kN}$$

$$+\uparrow \Sigma F_y = 0; \quad \frac{4}{5}(5.625) + \frac{4}{5}(5.625) - F_{CG} = 0$$

$$F_{CG} = 9.00 \text{ kN (T)} \quad \text{Ans}$$

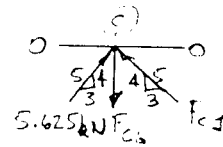
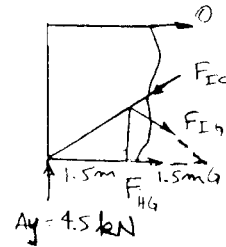

6-41. Determine the force in members JE and GF of the truss and state if these members are in tension or compression. Also, indicate all zero-force members.

By inspection of joints B , D , H and I ,

AB , BC , CD , DE , HI , and GI are zero-force members. **Ans**

Joint E :

$$+\uparrow \Sigma F_y = 0; \quad 7.5 - \frac{4}{5}F_{JE} = 0$$

$$F_{JE} = 9.375 = 9.38 \text{ kN (C)} \quad \text{Ans}$$

$$\rightarrow \Sigma F_x = 0; \quad \frac{3}{5}(9.375) - F_{GF} = 0$$

$$F_{GF} = 5.625 \text{ kN (T)} \quad \text{Ans}$$

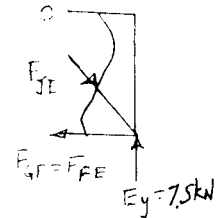

6-42. Determine the force in members BC , HC , and HG . After the truss is sectioned use a single equation of equilibrium for the calculation of each force. State if these members are in tension or compression.

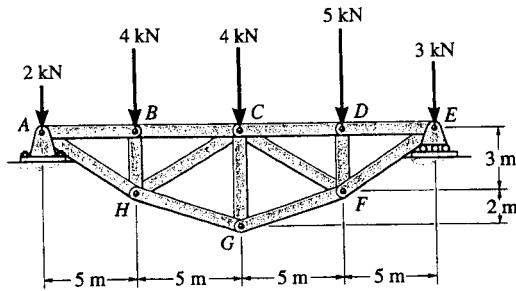

Probs. 6-42/43

$$\curvearrowleft + \Sigma M_E = 0; \quad -A_y(20) + 2(20) + 4(15) + 4(10) + 5(5) = 0$$

$$A_y = 8.25 \text{ kN}$$

$$\curvearrowleft + \Sigma M_H = 0; \quad -8.25(5) + 2(5) + F_{BC}(3) = 0$$

$$F_{BC} = 10.4 \text{ kN (C)}$$

$$\curvearrowleft + \Sigma M_C = 0; \quad -8.25(10) + 2(10) + 4(5) + \frac{5}{\sqrt{29}} F_{HG}(5) = 0$$

$$F_{HG} = 9.155 = 9.16 \text{ kN (T)} \quad \text{Ans}$$

$$\curvearrowleft + \Sigma M_{O'} = 0; \quad -2(2.5) + 8.25(2.5) - 4(7.5) + \frac{3}{\sqrt{34}} F_{HC}(12.5) = 0$$

$$F_{HC} = 2.24 \text{ kN (T)} \quad \text{Ans}$$

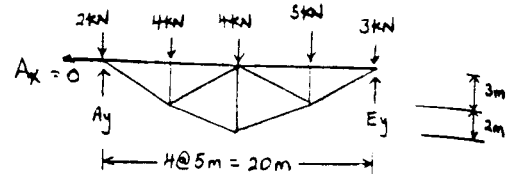

Ans

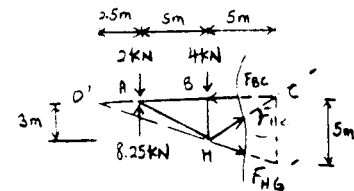

6-43. Determine the force in members CD , CF , and CG and state if these members are in tension or compression.

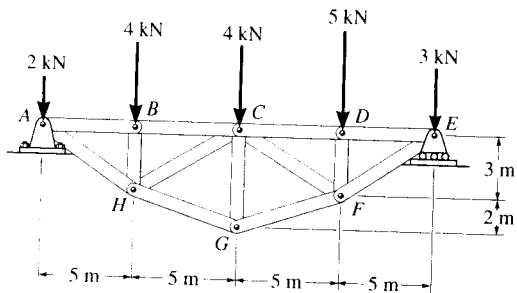

$$\rightarrow \Sigma F_x = 0; \quad E_x = 0$$

$$\curvearrow + \Sigma M_A = 0; \quad -4(5) - 4(10) - 5(15) - 3(20) + E_y(20) = 0$$

$$E_y = 9.75 \text{ kN}$$

$$\curvearrow + \Sigma M_C = 0; \quad -5(5) - 3(10) + 9.75(10) - \frac{5}{\sqrt{29}} F_{FG}(5) = 0$$

$$F_{FG} = 9.155 \text{ kN (T)}$$

$$\curvearrow + \Sigma M_F = 0; \quad -3(5) + 9.75(5) - F_{CD}(3) = 0$$

$$F_{CD} = 11.25 = 11.2 \text{ kN (C)} \quad \text{Ans}$$

$$\curvearrow + \Sigma M_{O'} = 0; \quad -9.75(2.5) + 5(7.5) + 3(2.5) - \frac{3}{\sqrt{34}} F_{CF}(12.5) = 0$$

$$F_{CF} = 3.21 \text{ kN (T)} \quad \text{Ans}$$

Joint G :

$$\rightarrow \Sigma F_x = 0; \quad F_{GH} = 9.155 \text{ kN (T)}$$

$$+ \uparrow \Sigma F_y = 0; \quad \frac{2}{\sqrt{29}}(9.155)(2) - F_{CG} = 0$$

$$F_{CG} = 6.80 \text{ kN (C)} \quad \text{Ans}$$

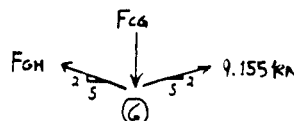
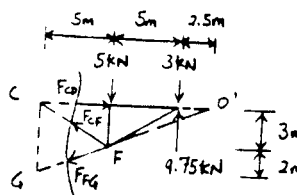
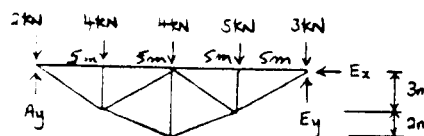

*6-44. Determine the force in members GF , FB , and BC of the Fink truss and state if the members are in tension or compression.

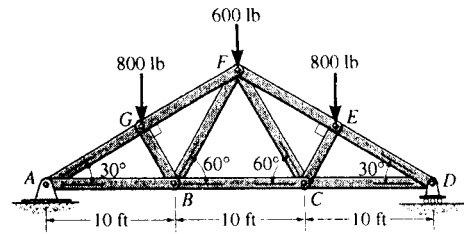

Support Reactions : Due to symmetry, $D_y = A_y$.

$$+\uparrow \Sigma F_y = 0; \quad 2A_y - 800 - 600 - 800 = 0 \quad A_y = 1100 \text{ lb}$$

$$\rightarrow \Sigma F_x = 0; \quad A_x = 0$$

Method of Sections :

$$\begin{aligned} (+\Sigma M_B = 0; \quad & F_{GF} \sin 30^\circ (10) + 800(10 - 10\cos^2 30^\circ) - 1100(10) = 0 \\ & F_{GF} = 1800 \text{ lb (C)} = 1.80 \text{ kip (C)} \quad \text{Ans} \end{aligned}$$

$$\begin{aligned} (+\Sigma M_A = 0; \quad & F_{FB} \sin 60^\circ (10) - 800(10\cos^2 30^\circ) = 0 \\ & F_{FB} = 692.82 \text{ lb (T)} = 693 \text{ lb (T)} \quad \text{Ans} \end{aligned}$$

$$\begin{aligned} (+\Sigma M_F = 0; \quad & F_{BC} (15 \tan 30^\circ) + 800(15 - 10\cos^2 30^\circ) - 1100(15) = 0 \\ & F_{BC} = 1212.43 \text{ lb (T)} = 1.21 \text{ kip (T)} \quad \text{Ans} \end{aligned}$$

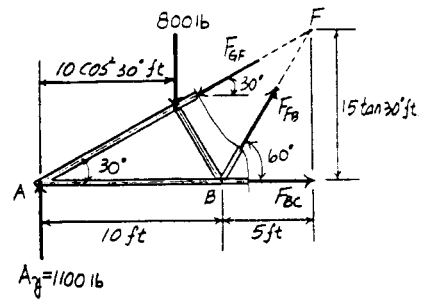
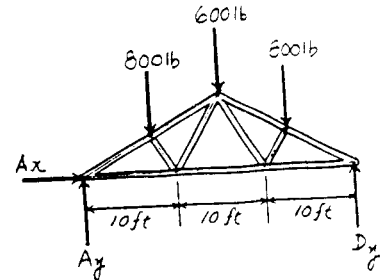

6-45. Determine the force in member GJ of the truss and state if this member is in tension or compression.

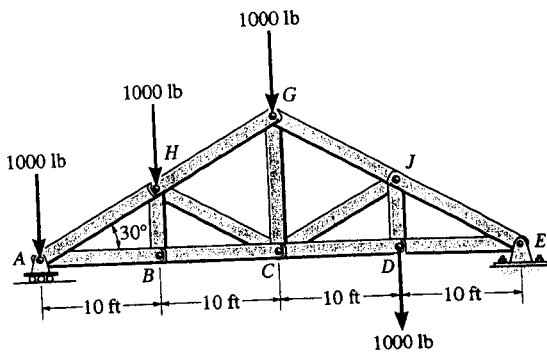

$$(+\Sigma M_C = 0; \quad -1000(10) + 1500(20) - F_{GJ} \cos 30^\circ (20 \tan 30^\circ) = 0$$

$$F_{GJ} = 2.00 \text{ kip (C)} \quad \text{Ans}$$

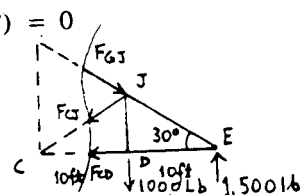

6-46. Determine the force in member GC of the truss and state if this member is in tension or compression.

Using the results of Prob. 6-45:

Joint G :

$$\rightarrow \Sigma F_x = 0; \quad F_{HG} = 2000 \text{ lb}$$

$$+ \uparrow \Sigma F_y = 0; \quad -1000 + 2(2000 \cos 60^\circ) - F_{GC} = 0$$

$$F_{GC} = 1.00 \text{ kip (T)}$$

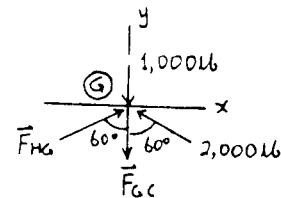
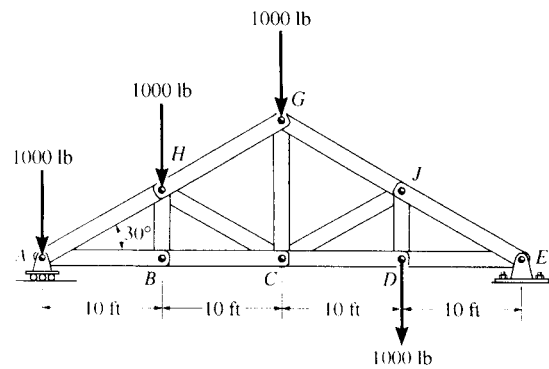

6-47. Determine the force in members GF , CF , and CD of the roof truss and indicate if the members are in tension or compression.

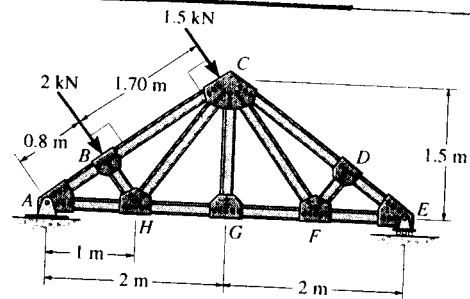

$$\left(+ \Sigma M_A = 0; \quad E_y(4) - 2(0.8) - 1.5(2.50) = 0 \quad E_y = 1.3375 \text{ kN} \right.$$

Method of Sections:

$$\left(+ \Sigma M_C = 0; \quad 1.3375(2) - F_{GF}(1.5) = 0 \right. \\ \left. F_{GF} = 1.78 \text{ kN (T)} \right. \quad \text{Ans}$$

$$\left(+ \Sigma M_F = 0; \quad 1.3375(1) - F_{CD}\left(\frac{3}{5}\right)(1) = 0 \right. \\ \left. F_{CD} = 2.23 \text{ kN (C)} \right. \quad \text{Ans}$$

$$\left(+ \Sigma M_E = 0; \quad F_{CF}\left(\frac{1.5}{\sqrt{3.25}}\right)(1) = 0 \quad F_{CF} = 0 \right. \quad \text{Ans}$$

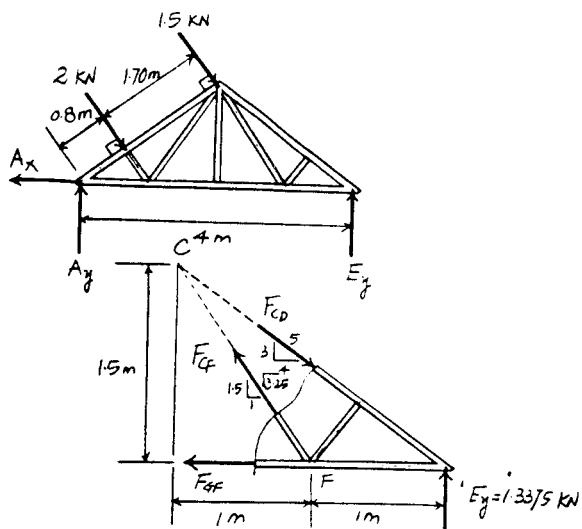

*6-48. Determine the force in members BG , HG , and BC of the truss and state if the members are in tension or compression.

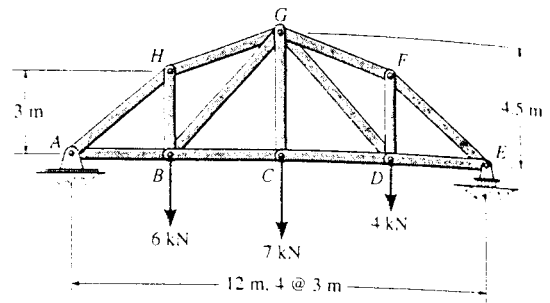

$$\left(+ \Sigma M_E = 0; \quad 6(9) + 7(6) + 4(3) - A_y(12) = 0 \quad A_y = 9.00 \text{ kN} \right.$$

$$\left(\rightarrow \Sigma F_x = 0; \quad A_x = 0 \right.$$

Method of Sections :

$$\left(+ \Sigma M_G = 0; \quad F_{BC}(4.5) + 6(3) - 9(6) = 0 \right.$$

$$F_{BC} = 8.00 \text{ kN (T)}$$

Ans

$$\left(+ \Sigma M_B = 0; \quad F_{HG} \left(\frac{1}{\sqrt{5}} \right) (6) - 9(3) = 0 \right.$$

$$F_{HG} = 10.1 \text{ kN (C)}$$

Ans

$$\left(+ \Sigma M_O = 0; \quad F_{BG} \left(\frac{1.5}{\sqrt{3.25}} \right) (6) + 9(3) - 6(6) = 0 \right.$$

$$F_{BG} = 1.80 \text{ kN (T)}$$

Ans

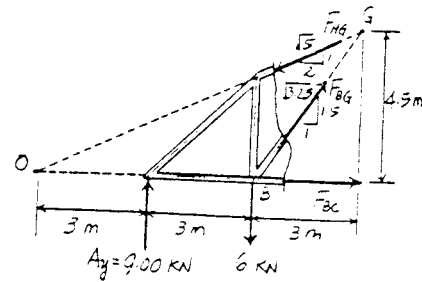
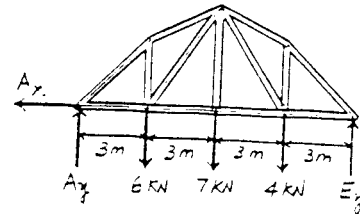

6-49. The skewed truss carries the load shown. Determine the force in members CB , BE , and EF and state if these members are in tension or compression. Assume that all joints are pinned.

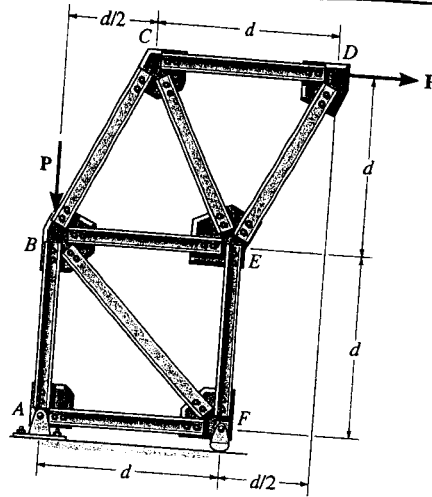

$$\curvearrowleft + \Sigma M_B = 0; \quad -P(d) + F_{EF}(d) = 0$$

$$F_{EF} = P \text{ (C)} \quad \text{Ans}$$

$$\curvearrowleft + \Sigma M_E = 0; \quad -P(d) + \left[\frac{d}{\sqrt{(d)^2 + (\frac{d}{2})^2}} \right] F_{CB}(d) = 0$$

$$F_{CB} = 1.12P \text{ (T)} \quad \text{Ans}$$

$$\rightarrow \Sigma F_x = 0; \quad P - \frac{0.5}{\sqrt{1.25}}(1.12P) - F_{BE} = 0$$

$$F_{BE} = 0.5P \text{ (T)} \quad \text{Ans}$$

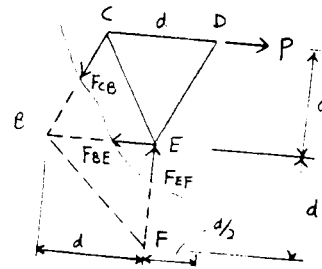

6-50. The skewed truss carries the load shown. Determine the force in members AB , BF , and EF and state if these members are in tension or compression. Assume that all joints are pinned.

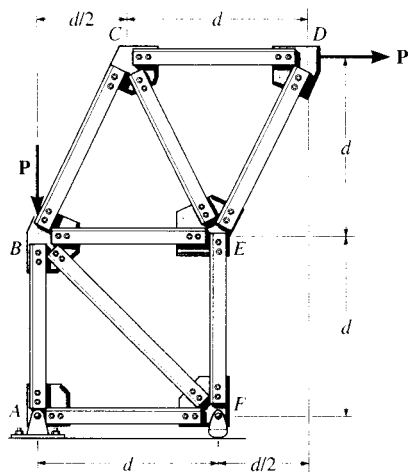

$$\curvearrowleft + \Sigma M_F = 0; \quad -P(2d) + P(d) + F_{AB}(d) = 0$$

$$F_{AB} = P \text{ (T)} \quad \text{Ans}$$

$$\curvearrowleft + \Sigma M_B = 0; \quad -P(d) + F_{EF}(d) = 0$$

$$F_{EF} = P \text{ (C)} \quad \text{Ans}$$

$$\rightarrow \Sigma F_x = 0; \quad P - F_{BF}\left(\frac{1}{\sqrt{2}}\right) = 0$$

$$F_{BF} = 1.41P \text{ (C)} \quad \text{Ans}$$

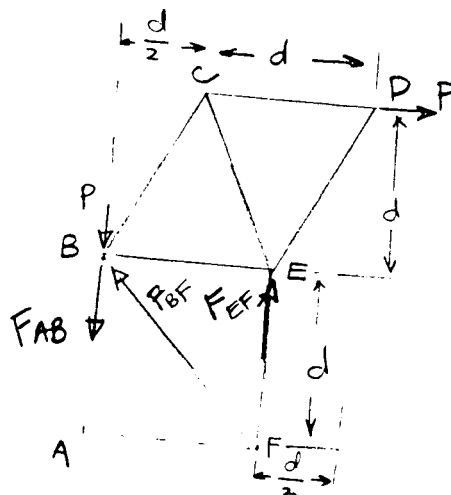

*6-51. Determine the force in members CD and CM of the *Baltimore bridge truss* and state if the members are in tension or compression. Also, indicate all zero-force members.

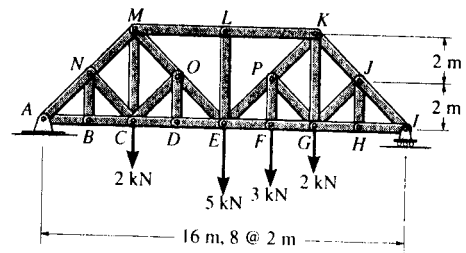

Support Reactions :

$$\begin{aligned} \sum M_I = 0; & \quad 2(12) + 5(8) + 3(6) + 2(4) - A_y(16) = 0 \\ & \quad A_y = 5.625 \text{ kN} \end{aligned}$$

$$\sum F_x = 0; \quad A_x = 0$$

Method of Joints : By inspection, members BN, NC, DO, OC, HJ and LE and JG are zero force member.

Ans

Method of Sections :

$$\begin{aligned} \sum M_M = 0; & \quad F_{CD}(4) - 5.625(4) = 0 \\ & \quad F_{CD} = 5.625 \text{ kN (T)} \end{aligned}$$

Ans

$$\begin{aligned} \sum M_A = 0; & \quad F_{CM}(4) - 2(4) = 0 \\ & \quad F_{CM} = 2.00 \text{ kN (T)} \end{aligned}$$

Ans

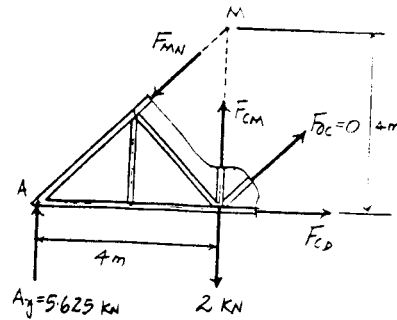

*6-52. Determine the force in members $EF, EP,$ and LK of the *Baltimore bridge truss* and state if the members are in tension or compression. Also, indicate all zero-force members.

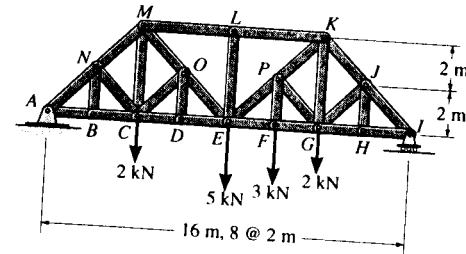

Support Reactions :

$$\begin{aligned} \sum M_A = 0; & \quad I_y(16) - 2(12) - 3(10) - 5(8) - 2(4) = 0 \\ & \quad I_y = 6.375 \text{ kN} \end{aligned}$$

Method of Joints : By inspection, members BN, NC, DO, OC, HJ and LE and JG are zero force member.

Ans

Method of Sections :

$$\begin{aligned} \sum M_K = 0; & \quad 3(2) + 6.375(4) - F_{EP}(4) = 0 \\ & \quad F_{EP} = 7.875 \text{ kN (T)} \end{aligned}$$

Ans

$$\begin{aligned} \sum M_E = 0; & \quad 6.375(8) - 2(4) - 3(2) - F_{LK}(4) = 0 \\ & \quad F_{LK} = 9.25 \text{ kN (C)} \end{aligned}$$

Ans

$$\begin{aligned} \sum F_y = 0; & \quad 6.375 - 3 - 2 - F_{ED} \sin 45^\circ = 0 \\ & \quad F_{EP} = 1.94 \text{ kN (T)} \end{aligned}$$

Ans

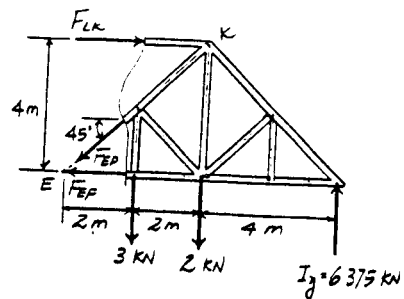

6-53. Determine the force in members KJ , NJ , ND , and CD of the K truss. Indicate if the members are in tension or compression. *Hint: Use sections aa and bb .*

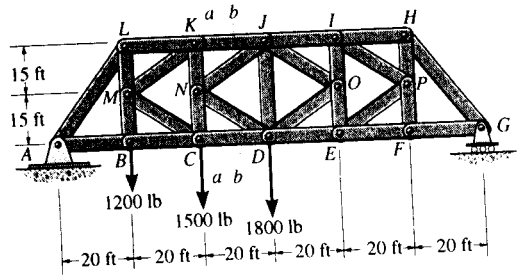

Support Reactions :

$$\begin{aligned} \curvearrowright + \Sigma M_G = 0; & \quad 1.20(100) + 1.50(80) + 1.80(60) - A_y(120) = 0 \\ & \quad A_y = 2.90 \text{ kip} \end{aligned}$$

$$\rightarrow \Sigma F_x = 0; \quad A_x = 0$$

Method of Sections : From section $a-a$, F_{KJ} and F_{CD} can be obtained directly by summing moment about points C and K respectively.

$$\begin{aligned} \curvearrowright + \Sigma M_C = 0; & \quad F_{KJ}(30) + 1.20(20) - 2.90(40) = 0 \\ & \quad F_{KJ} = 3.067 \text{ kip (C)} = 3.07 \text{ kip (C)} \quad \text{Ans} \end{aligned}$$

$$\begin{aligned} \curvearrowright + \Sigma M_K = 0; & \quad F_{CD}(30) + 1.20(20) - 2.90(40) = 0 \\ & \quad F_{CD} = 3.067 \text{ kip (T)} = 3.07 \text{ kip (T)} \quad \text{Ans} \end{aligned}$$

From sec $b-b$, summing forces along x and y axes yields

$$\begin{aligned} \rightarrow \Sigma F_x = 0; & \quad F_{ND}\left(\frac{4}{5}\right) - F_{NJ}\left(\frac{4}{5}\right) + 3.067 - 3.067 = 0 \\ & \quad F_{ND} = F_{NJ} \quad [1] \end{aligned}$$

$$\begin{aligned} + \uparrow \Sigma F_y = 0; & \quad 2.90 - 1.20 - 1.50 - F_{ND}\left(\frac{3}{5}\right) - F_{NJ}\left(\frac{3}{5}\right) = 0 \\ & \quad F_{ND} + F_{NJ} = 0.3333 \quad [2] \end{aligned}$$

Solving Eqs. [1] and [2] yields

$$F_{ND} = 0.167 \text{ kip (T)} \quad F_{NJ} = 0.167 \text{ kip (C)} \quad \text{Ans}$$

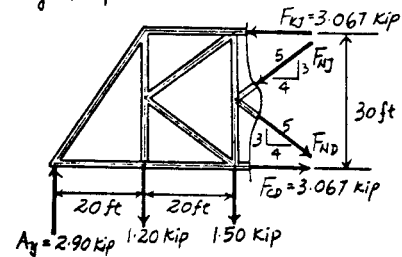
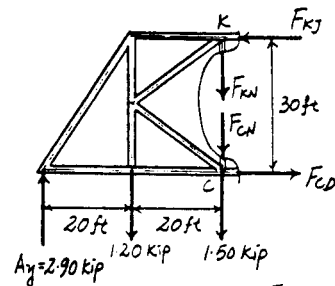
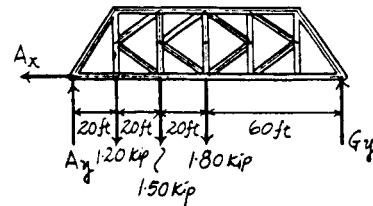

6-54. Determine the force in members JI and DE of the K truss. Indicate if the members are in tension or compression.

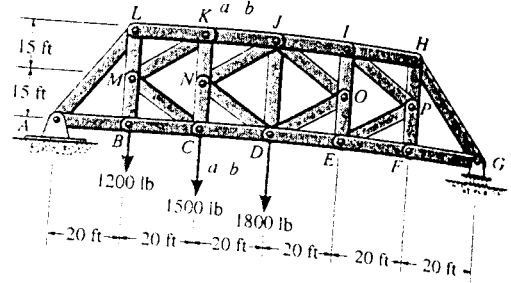

Support Reactions:

$$\begin{aligned} \sum M_A = 0; \quad G_y(120) - 1.30(60) - 1.50(40) - 1.20(20) &= 0 \\ G_y &= 1.60 \text{ kip} \end{aligned}$$

Method of Sections:

$$\begin{aligned} \sum M_E = 0; \quad 1.60(40) - F_{JI}(30) &= 0 \\ F_{JI} &= 2.13 \text{ kip (C)} \end{aligned}$$

Ans

$$\begin{aligned} \sum M_I = 0; \quad 1.60(40) - F_{DE}(30) &= 0 \\ F_{DE} &= 2.13 \text{ kip (T)} \end{aligned}$$

Ans

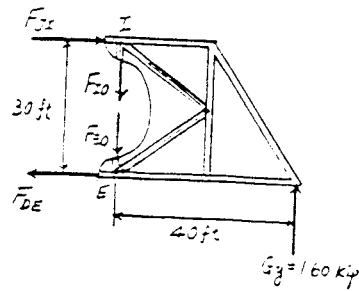

6-55. Determine the force in each member of the three-member space truss that supports the loading of 1000 lb and state if the members are in tension or compression.

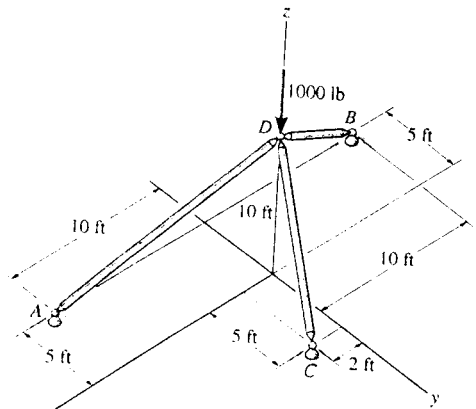

Joint D:

$$F_{AD} = F_{AD} \left(-\frac{10}{15} \mathbf{i} + \frac{5}{15} \mathbf{j} + \frac{10}{15} \mathbf{k} \right)$$

$$F_{CD} = F_{CD} \left(-\frac{2}{11.358} \mathbf{i} - \frac{5}{11.358} \mathbf{j} + \frac{10}{11.358} \mathbf{k} \right)$$

$$F_{BD} = F_{BD} \left(\frac{10}{15} \mathbf{i} + \frac{5}{15} \mathbf{j} + \frac{10}{15} \mathbf{k} \right)$$

$$P = -1000 \mathbf{k}$$

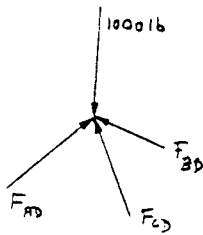

$$\sum F_x = 0; \quad F_{AD} \left(-\frac{10}{15} \right) + F_{CD} \left(-\frac{2}{11.358} \right) + F_{BD} \left(\frac{10}{15} \right) = 0$$

$$\sum F_y = 0; \quad F_{AD} \left(\frac{5}{15} \right) + F_{CD} \left(-\frac{5}{11.358} \right) + F_{BD} \left(\frac{5}{15} \right) = 0$$

$$\sum F_z = 0; \quad F_{AD} \left(\frac{10}{15} \right) + F_{CD} \left(\frac{10}{11.358} \right) + F_{BD} \left(\frac{10}{15} \right) - 1000 = 0$$

Solving,

$$F_{AD} = 300 \text{ lb (C)} \quad \text{Ans}$$

$$F_{BD} = 450 \text{ lb (C)} \quad \text{Ans}$$

$$F_{CD} = 568 \text{ lb (C)} \quad \text{Ans}$$

*6-56. Determine the force in each member of the space truss and state if the members are in tension or compression. *Hint:* The support reaction at E acts along member EB . Why?

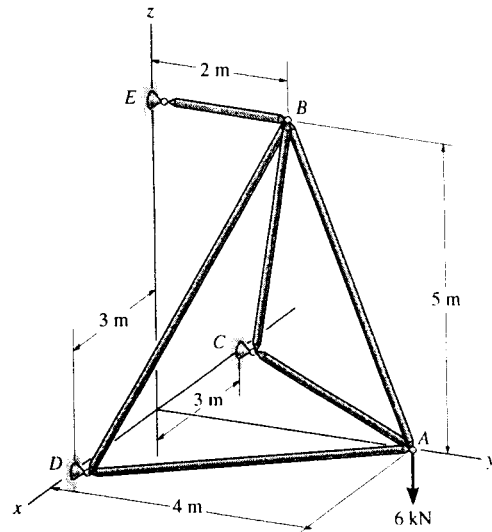

Method of Joints : In this case, the support reactions are not required for determining the member forces.

Joint A

$$\Sigma F_z = 0; \quad F_{AB} \left(\frac{5}{\sqrt{29}} \right) - 6 = 0$$

$$F_{AB} = 6.462 \text{ kN (T)} = 6.46 \text{ kN (T)} \quad \text{Ans}$$

$$\Sigma F_x = 0; \quad F_{AC} \left(\frac{3}{5} \right) - F_{AD} \left(\frac{3}{5} \right) = 0 \quad F_{AC} = F_{AD} \quad [1]$$

$$\Sigma F_y = 0; \quad F_{AC} \left(\frac{4}{5} \right) + F_{AD} \left(\frac{4}{5} \right) - 6.462 \left(\frac{2}{\sqrt{29}} \right) = 0$$

$$F_{AC} + F_{AD} = 3.00 \quad [2]$$

Solving Eqs. [1] and [2] yields

$$F_{AC} = F_{AD} = 1.50 \text{ kN (C)} \quad \text{Ans}$$

Joint B

$$\Sigma F_x = 0; \quad F_{BC} \left(\frac{3}{\sqrt{38}} \right) - F_{BD} \left(\frac{3}{\sqrt{38}} \right) = 0 \quad F_{BC} = F_{BD} \quad [1]$$

$$\Sigma F_z = 0; \quad F_{BC} \left(\frac{5}{\sqrt{38}} \right) + F_{BD} \left(\frac{5}{\sqrt{38}} \right) - 6.462 \left(\frac{5}{\sqrt{29}} \right) = 0$$

$$F_{BC} + F_{BD} = 7.397 \quad [2]$$

Solving Eqs. [1] and [2] yields

$$F_{BC} = F_{BD} = 3.699 \text{ kN (C)} = 3.70 \text{ kN (C)} \quad \text{Ans}$$

$$\Sigma F_y = 0; \quad 2 \left[3.699 \left(\frac{2}{\sqrt{38}} \right) \right] + 6.462 \left(\frac{2}{\sqrt{29}} \right) - F_{BE} = 0$$

$$F_{BE} = 4.80 \text{ kN (T)} \quad \text{Ans}$$

Note : The support reactions at supports C and D can be determined by analyzing joints C and D , respectively using the results obtained above.

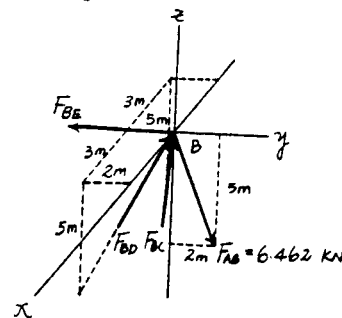
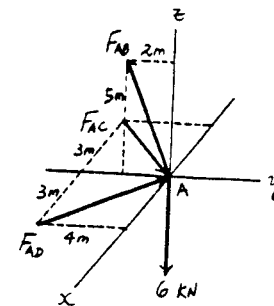

6-57. Determine the force in each member of the space truss and state if the members are in tension or compression. The truss is supported by rollers at A, B, and C.

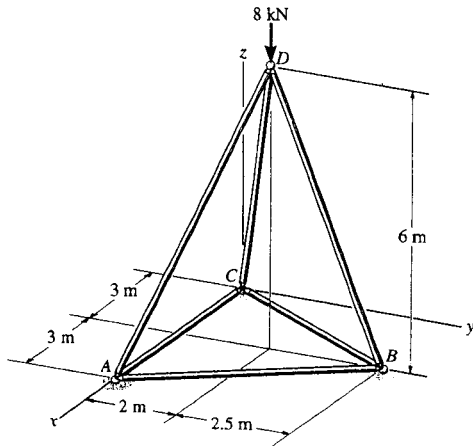

$$\Sigma F_x = 0; \quad \frac{3}{7}F_{DC} - \frac{3}{7}F_{DA} = 0$$

$$F_{DC} = F_{DA}$$

$$\Sigma F_y = 0; \quad \frac{2}{7}F_{DC} + \frac{2}{7}F_{DA} - \frac{2.5}{6.5}F_{DB} = 0$$

$$F_{DB} = 1.486 F_{DC}$$

$$\Sigma F_z = 0; \quad -8 + 2\left(\frac{6}{7}\right)F_{DC} + \frac{6}{6.5}F_{DB} = 0$$

$$F_{DC} = F_{DA} = 2.59 \text{ kN (C)}$$

Ans

$$F_{DB} = 3.85 \text{ kN (C)}$$

Ans

$$\Sigma F_x = 0; \quad F_{BC} = F_{BA}$$

$$\Sigma F_y = 0; \quad 3.85\left(\frac{2.5}{6.5}\right) - 2\left(\frac{4.5}{\sqrt{29.25}}\right)F_{BC} = 0$$

$$F_{BC} = F_{BA} = 0.890 \text{ kN (T)}$$

Ans

$$\Sigma F_x = 0; \quad 2.59\left(\frac{3}{7}\right) - 0.890\left(\frac{3}{\sqrt{29.25}}\right) - F_{AC} = 0$$

$$F_{AC} = 0.616 \text{ kN (T)}$$

Ans

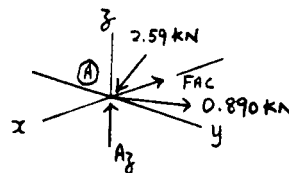
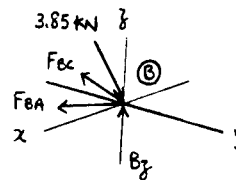
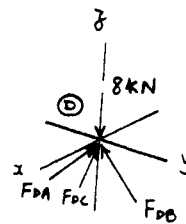

*6-58. The space truss is supported by a ball-and-socket joint at D and short links at C and E . Determine the force in each member and state if the members are in tension or compression. Take $\mathbf{F}_1 = \{-500\mathbf{k}\}$ lb and $\mathbf{F}_2 = \{400\mathbf{j}\}$ lb.

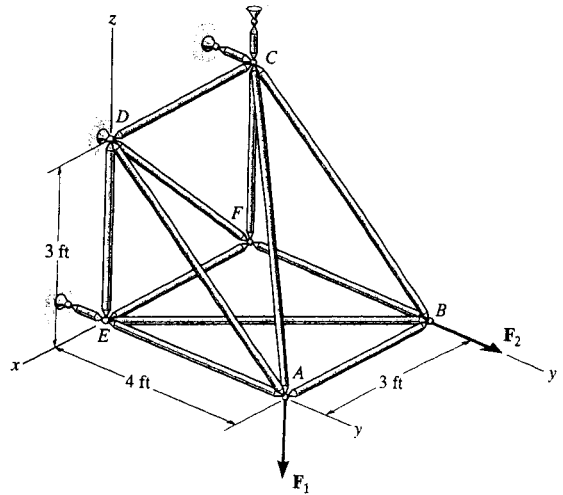

$$\Sigma M_z = 0; \quad -C_y(3) - 400(3) = 0$$

$$C_y = -400 \text{ lb}$$

$$\Sigma F_x = 0; \quad D_x = 0$$

$$\Sigma M_y = 0; \quad C_z = 0$$

Joint F : $\Sigma F_y = 0; \quad F_{BF} = 0 \quad \text{Ans}$

Joint B :

$$\Sigma F_z = 0; \quad F_{BC} = 0 \quad \text{Ans}$$

$$\Sigma F_y = 0; \quad 400 - \frac{4}{5}F_{BE} = 0$$

$$F_{BE} = 500 \text{ lb (T)} \quad \text{Ans}$$

$$\Sigma F_x = 0; \quad F_{AB} - \frac{3}{5}(500) = 0$$

$$F_{AB} = 300 \text{ lb (C)} \quad \text{Ans}$$

Joint A :

$$\Sigma F_x = 0; \quad 300 - \frac{3}{\sqrt{34}}F_{AC} = 0$$

$$F_{AC} = 583.1 = 583 \text{ lb (T)} \quad \text{Ans}$$

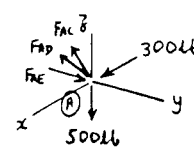
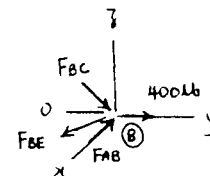
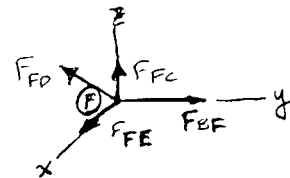
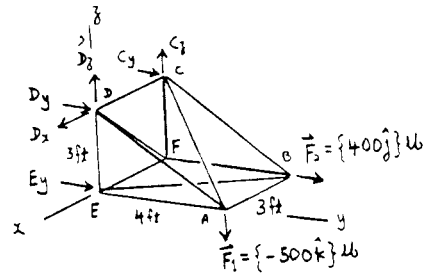

6-58 Cont'd

$$\Sigma F_z = 0; \quad \frac{3}{\sqrt{34}}(583.1) - 500 + \frac{3}{5}F_{AD} = 0$$

$$F_{AD} = 333 \text{ lb (T)} \quad \text{Ans}$$

$$\Sigma F_y = 0; \quad F_{AE} - \frac{4}{5}(333.3) - \frac{4}{\sqrt{34}}(583.1) = 0$$

$$F_{AE} = 667 \text{ lb (C)} \quad \text{Ans}$$

Joint E:

$$\Sigma F_z = 0; \quad F_{DE} = 0 \quad \text{Ans}$$

$$\Sigma F_x = 0; \quad F_{EF} - \frac{3}{5}(500) = 0$$

$$F_{EF} = 300 \text{ lb (C)} \quad \text{Ans}$$

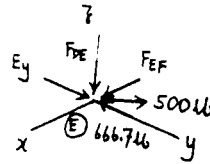

Joint C:

$$\Sigma F_x = 0; \quad \frac{3}{\sqrt{34}}(583.1) - F_{CD} = 0$$

$$F_{CD} = 300 \text{ lb (C)} \quad \text{Ans}$$

$$\Sigma F_z = 0; \quad F_{CF} - \frac{3}{\sqrt{34}}(583.1) = 0$$

$$F_{CF} = 300 \text{ lb (C)} \quad \text{Ans}$$

$$\Sigma F_y = 0; \quad \frac{4}{\sqrt{34}}(583.1) - 400 = 0 \quad \text{Check!}$$

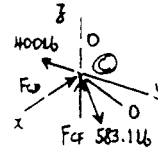

Joint F:

$$\Sigma F_x = 0; \quad \frac{3}{\sqrt{18}}F_{DF} - 300 = 0$$

$$F_{DF} = 424 \text{ lb (T)} \quad \text{Ans}$$

$$\Sigma F_z = 0; \quad \frac{3}{\sqrt{18}}(424.3) - 300 = 0 \quad \text{Check!}$$

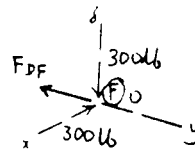

6-59. The space truss is supported by a ball-and-socket joint at D and short links at C and E . Determine the force in each member and state if the members are in tension or compression. Take $\mathbf{F}_1 = \{200\mathbf{i} + 300\mathbf{j} - 500\mathbf{k}\}$ lb and $\mathbf{F}_2 = \{400\mathbf{j}\}$ lb.

$$\Sigma F_x = 0; \quad D_x + 200 = 0$$

$$D_x = -200 \text{ lb}$$

$$\Sigma M_z = 0; \quad -C_y(3) - 400(3) - 200(4) = 0$$

$$C_y = -666.7 \text{ lb}$$

$$\Sigma M_y = 0; \quad C_z(3) - 200(3) = 0$$

$$C_z = 200 \text{ lb}$$

Joint F : $F_{BF} = 0$ **Ans**

Joint B :

$$\Sigma F_z = 0; \quad F_{BC} = 0$$
 Ans

$$\Sigma F_y = 0; \quad 400 - \frac{4}{5}F_{BE} = 0$$

$$F_{BE} = 500 \text{ lb (T)}$$
 Ans

$$\Sigma F_x = 0; \quad F_{AB} - \frac{3}{5}(500) = 0$$

$$F_{AB} = 300 \text{ lb (C)}$$
 Ans

Joint A :

$$\Sigma F_x = 0; \quad 300 + 200 - \frac{3}{\sqrt{34}}F_{AC} = 0$$

$$F_{AC} = 971.8 = 972 \text{ lb (T)}$$
 Ans

$$\Sigma F_z = 0; \quad \frac{3}{\sqrt{34}}(971.8) - 500 + \frac{3}{5}F_{AD} = 0$$

$$F_{AD} = 0$$
 Ans

$$\Sigma F_y = 0; \quad F_{AE} + 300 - \frac{4}{\sqrt{34}}(971.8) = 0$$

$$F_{AE} = 367 \text{ lb (C)}$$
 Ans

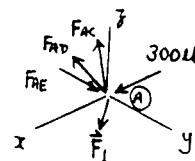
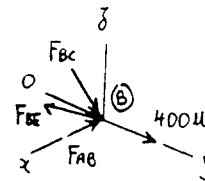
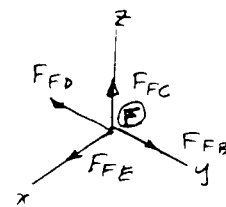
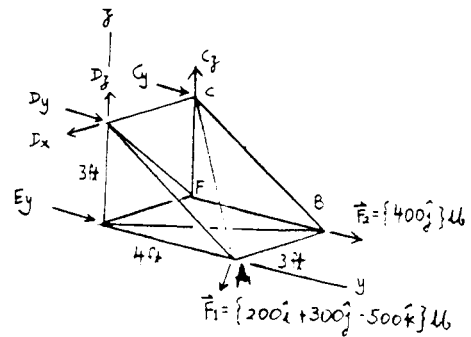

Cor

6-59 cont'd

Joint E :

$$\Sigma F_z = 0; \quad F_{DE} = 0 \quad \text{Ans}$$

$$\Sigma F_x = 0; \quad F_{EF} - \frac{3}{5}(500) = 0$$

$$F_{EF} = 300 \text{ lb (C)} \quad \text{Ans}$$

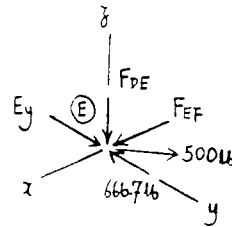

Joint C :

$$\Sigma F_x = 0; \quad \frac{3}{\sqrt{34}}(971.8) - F_{CD} = 0$$

$$F_{CD} = 500 \text{ lb (C)} \quad \text{Ans}$$

$$\Sigma F_z = 0; \quad F_{CF} - \frac{3}{\sqrt{34}}(971.8) + 200 = 0$$

$$F_{CF} = 300 \text{ lb (C)} \quad \text{Ans}$$

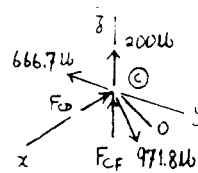

$$\Sigma F_y = 0; \quad \frac{4}{\sqrt{34}}(971.8) - 666.7 = 0 \quad \text{Check!}$$

Joint F :

$$\Sigma F_x = 0; \quad \frac{3}{\sqrt{18}}F_{DF} - 300 = 0$$

$$F_{DF} = 424 \text{ lb (T)} \quad \text{Ans}$$

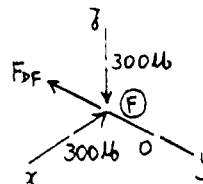

*6-62 Determine the force in each member of the space truss and state if the members are in tension or compression. The truss is supported by ball-and-socket joints at A, B, and E. Set $\mathbf{F} = \{-200\mathbf{i} + 400\mathbf{j}\}$ N. *Hint:* The support reaction at E acts along member EC. Why?

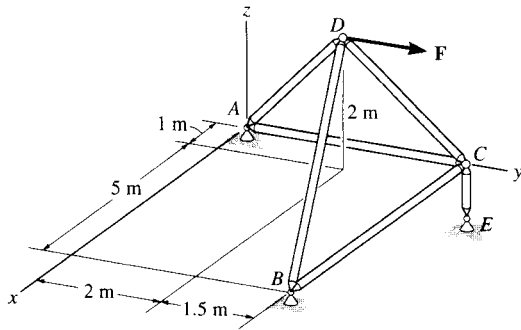

Joint D:

$$\Sigma F_x = 0; \quad -\frac{1}{3}F_{AD} + \frac{5}{\sqrt{31.25}}F_{BD} + \frac{1}{\sqrt{7.25}}F_{CD} - 200 = 0$$

$$\Sigma F_y = 0; \quad -\frac{2}{3}F_{AD} + \frac{1.5}{\sqrt{31.25}}F_{BD} - \frac{1.5}{\sqrt{7.25}}F_{CD} + 400 = 0$$

$$\Sigma F_z = 0; \quad -\frac{2}{3}F_{AD} - \frac{2}{\sqrt{31.25}}F_{BD} + \frac{2}{\sqrt{7.25}}F_{CD} = 0$$

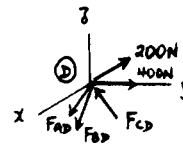

$$F_{AD} = 343 \text{ N (T)} \quad \text{Ans}$$

$$F_{BD} = 186 \text{ N (T)} \quad \text{Ans}$$

$$F_{CD} = 397 \text{ N (C)} \quad \text{Ans}$$

Joint C:

$$\Sigma F_x = 0; \quad F_{BC} - \frac{1}{\sqrt{7.25}}(397) = 0$$

$$F_{BC} = 148 \text{ N (T)} \quad \text{Ans}$$

$$\Sigma F_z = 0; \quad F_{EC} - \frac{2}{\sqrt{7.25}}(397) = 0$$

$$F_{EC} = 295 \text{ N (C)} \quad \text{Ans}$$

$$\Sigma F_y = 0; \quad \frac{1.5}{\sqrt{7.25}}(397) - F_{AC} = 0$$

$$F_{AC} = 221 \text{ N (T)} \quad \text{Ans}$$

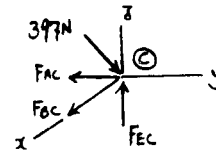

6-61. Determine the force in each member of the space truss and state if the members are in tension or compression. The truss is supported by ball-and-socket joints at C, D, E, and G.

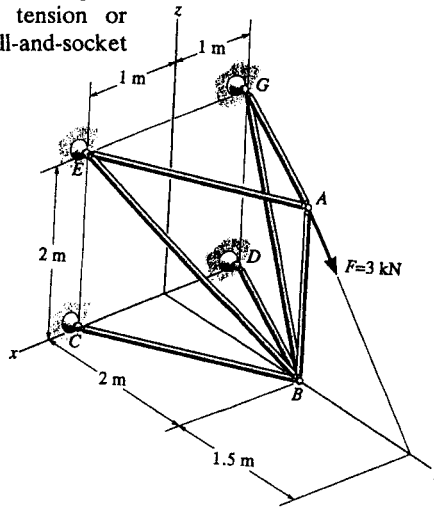

$$\Sigma(M_{EG})_x = 0;$$

$$\frac{2}{\sqrt{5}}F_{BC}(2) + \frac{2}{\sqrt{5}}F_{BD}(2) - \frac{4}{5}(3)(2) = 0$$

$$F_{BC} + F_{BD} = 2.683 \text{ kN}$$

Due to symmetry:

$$F_{BC} = F_{BD} = 1.342 = 1.34 \text{ kN (C)}$$

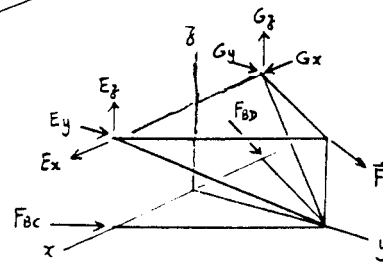

Ans

Joint A :

$$\Sigma F_z = 0;$$

$$F_{AB} - \frac{4}{5}(3) = 0$$

$$F_{AB} = 2.4 \text{ kN (C)}$$

Ans

$$\Sigma F_x = 0;$$

$$F_{AG} = F_{AE}$$

$$\Sigma F_y = 0;$$

$$\frac{3}{5}(3) - \frac{2}{\sqrt{5}}F_{AE} - \frac{2}{\sqrt{5}}F_{AG} = 0$$

$$F_{AG} = F_{AE} = 1.01 \text{ kN (T)}$$

Ans

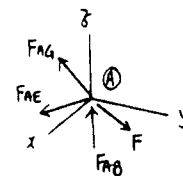

Joint B :

$$\Sigma F_x = 0;$$

$$\frac{1}{\sqrt{5}}(1.342) + \frac{1}{3}F_{BE} - \frac{1}{\sqrt{5}}(1.342) - \frac{1}{3}F_{BG} = 0$$

$$\Sigma F_y = 0;$$

$$\frac{2}{\sqrt{5}}(1.342) - \frac{2}{3}F_{BE} + \frac{2}{\sqrt{5}}(1.342) - \frac{2}{3}F_{BG} = 0$$

$$\Sigma F_z = 0;$$

$$\frac{2}{3}F_{BE} + \frac{2}{3}F_{BG} - 2.4 = 0$$

$$F_{BG} = 1.80 \text{ kN (T)}$$

Ans

$$F_{BE} = 1.80 \text{ kN (T)}$$

Ans

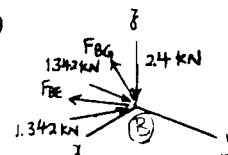

6-62. Determine the force in members BE , DF , and BC of the space truss and state if the members are in tension or compression.

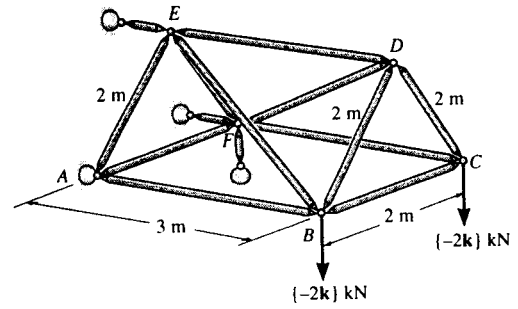

Method of Joints: In this case, the support reactions are not required for determining the member forces.

Joint C

$$\Sigma F_z = 0; \quad F_{CD} \sin 60^\circ - 2 = 0 \quad F_{CD} = 2.309 \text{ kN (T)}$$

$$\Sigma F_x = 0; \quad 2.309 \cos 60^\circ - F_{BC} = 0 \\ F_{BC} = 1.154 \text{ kN (C)} = 1.15 \text{ kN (C)} \quad \text{Ans}$$

Joint D Since F_{CD} , F_{DE} and F_{DF} lie within the same plane and F_{DB} is out of this plane, then $F_{DB} = 0$.

$$\Sigma F_x = 0; \quad F_{DF} \left(\frac{1}{\sqrt{13}} \right) - 2.309 \cos 60^\circ = 0 \\ F_{DF} = 4.16 \text{ kN (C)} \quad \text{Ans}$$

Joint B

$$\Sigma F_z = 0; \quad F_{BE} \left(\frac{1.732}{\sqrt{13}} \right) - 2 = 0 \\ F_{BE} = 4.16 \text{ kN (T)} \quad \text{Ans}$$

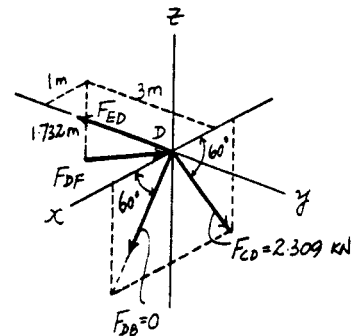
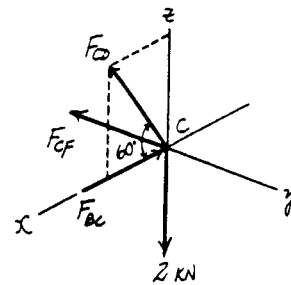

6-63. Determine the force in members AB , CD , ED , and CF of the space truss and state if the members are in tension or compression.

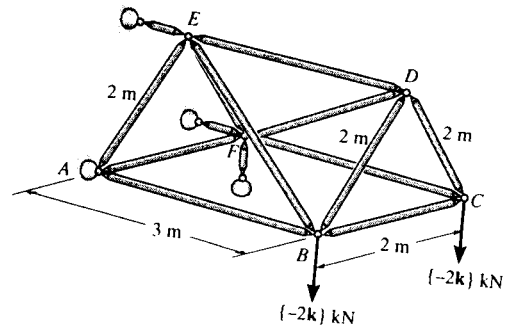

Method of Joints : In this case, the support reactions are not required for determining the member forces.

Joint C Since F_{CD} , F_{BC} and 2 kN force lie within the same plane and F_{CF} is out of this plane, then

$$F_{CF} = 0 \quad \text{Ans}$$

$$\begin{aligned} \Sigma F_z = 0; \quad F_{CD} \sin 60^\circ - 2 = 0 \\ F_{CD} = 2.309 \text{ kN (T)} = 2.31 \text{ kN (T)} \quad \text{Ans} \end{aligned}$$

$$\Sigma F_x = 0; \quad 2.309 \cos 60^\circ - F_{BC} = 0 \quad F_{BC} = 1.154 \text{ kN (C)}$$

Joint D Since F_{CD} , F_{DE} and F_{DF} lie within the same plane and F_{DB} is out of this plane, then $F_{DB} = 0$.

$$\begin{aligned} \Sigma F_x = 0; \quad F_{DF} \left(\frac{1}{\sqrt{13}} \right) - 2.309 \cos 60^\circ = 0 \\ F_{DF} = 4.163 \text{ kN (C)} \end{aligned}$$

$$\begin{aligned} \Sigma F_y = 0; \quad 4.163 \left(\frac{3}{\sqrt{13}} \right) - F_{ED} = 0 \\ F_{ED} = 3.46 \text{ kN (T)} \quad \text{Ans} \end{aligned}$$

Joint B

$$\Sigma F_z = 0; \quad F_{BB} \left(\frac{1.732}{\sqrt{13}} \right) - 2 = 0 \quad F_{BB} = 4.163 \text{ kN (T)}$$

$$\begin{aligned} \Sigma F_x = 0; \quad F_{AB} - 4.163 \left(\frac{3}{\sqrt{13}} \right) = 0 \\ F_{AB} = 3.46 \text{ kN (C)} \quad \text{Ans} \end{aligned}$$

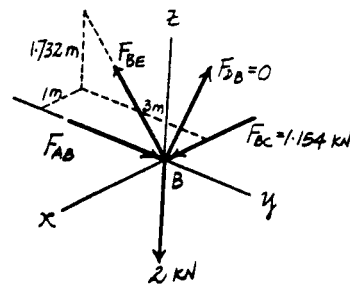

*6-64. Determine the force developed in each member of the space truss and state if the members are in tension or compression. The crate has a weight of 150 lb.

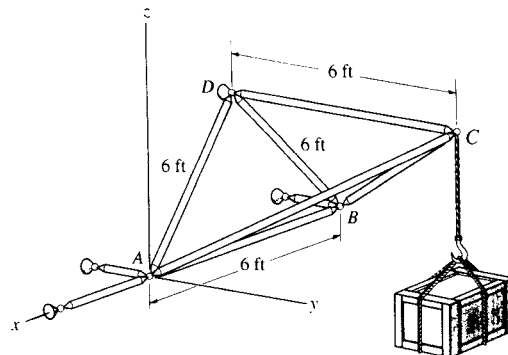

$$\mathbf{F}_{CA} = F_{CA} \left[\frac{-1\mathbf{i} + 2\mathbf{j} + 2 \sin 60^\circ \mathbf{k}}{\sqrt{8}} \right]$$

$$= -0.354 F_{CA} \mathbf{i} + 0.707 F_{CA} \mathbf{j} + 0.612 F_{CA} \mathbf{k}$$

$$\mathbf{F}_{CB} = 0.354 F_{CB} \mathbf{i} + 0.707 F_{CB} \mathbf{j} + 0.612 F_{CB} \mathbf{k}$$

$$\mathbf{F}_{CD} = -F_{CD} \mathbf{j}$$

$$\mathbf{W} = -150 \mathbf{k}$$

$$\Sigma F_x = 0; \quad -0.354 F_{CA} + 0.354 F_{CB} = 0$$

$$\Sigma F_y = 0; \quad 0.707 F_{CA} + 0.707 F_{CB} - F_{CD} = 0$$

$$\Sigma F_z = 0; \quad 0.612 F_{CA} + 0.612 F_{CB} - 150 = 0$$

Solving :

$$F_{CA} = F_{CB} = 122.5 \text{ lb} = 122 \text{ lb (C)}$$

$$F_{CD} = 173 \text{ lb (T)}$$

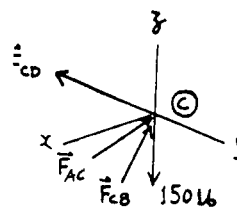

Ans

$$\mathbf{F}_{BA} = F_{BA} \mathbf{i}$$

$$\mathbf{F}_{BD} = F_{BD} \cos 60^\circ \mathbf{i} + F_{BD} \sin 60^\circ \mathbf{k}$$

$$\mathbf{F}_{CB} = 122.5 (-0.354 \mathbf{i} - 0.707 \mathbf{j} - 0.612 \mathbf{k})$$

$$= -43.3 \mathbf{i} - 86.6 \mathbf{j} - 75.0 \mathbf{k}$$

$$\Sigma F_x = 0; \quad F_{BA} + F_{BD} \cos 60^\circ - 43.3 = 0$$

$$\Sigma F_z = 0; \quad F_{BD} \sin 60^\circ - 75 = 0$$

Solving :

$$F_{BD} = 86.6 \text{ lb (T)}$$

Ans

$$F_{BA} = 0$$

Ans

$$\mathbf{F}_{AC} = 122.5 (0.354 F_{AC} \mathbf{i} - 0.707 F_{AC} \mathbf{j} - 0.612 F_{AC} \mathbf{k})$$

$$\Sigma F_z = 0; \quad F_{DA} \cos 30^\circ - 0.612 (122.5) = 0$$

$$F_{DA} = 86.6 \text{ lb (T)}$$

Ans

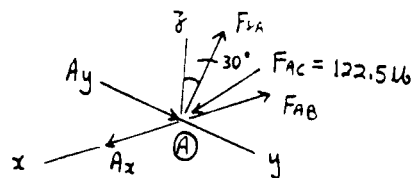
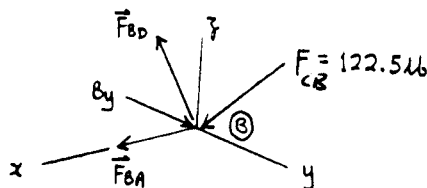

6-65. The space truss is used to support vertical forces at joints B , C , and D . Determine the force in each member and state if the members are in tension or compression.

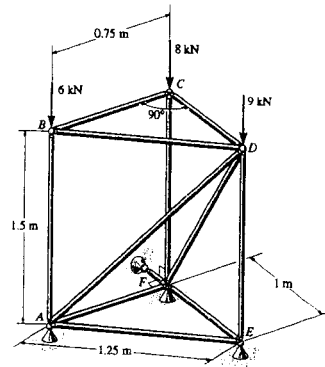

Prob. 6-65

Joint C :

$$\Sigma F_x = 0; \quad F_{BC} = 0 \quad \text{Ans}$$

$$\Sigma F_y = 0; \quad F_{CD} = 0 \quad \text{Ans}$$

$$\Sigma F_z = 0; \quad F_{CF} = 8 \text{ kN (C)} \quad \text{Ans}$$

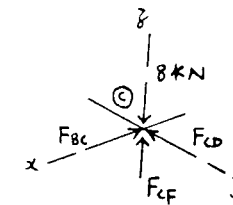

Joint B :

$$\Sigma F_y = 0; \quad F_{BD} = 0 \quad \text{Ans}$$

$$\Sigma F_z = 0; \quad F_{BA} = 6 \text{ kN (C)} \quad \text{Ans}$$

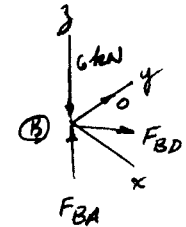
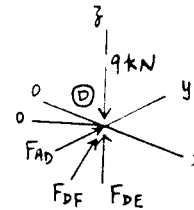

Joint D :

$$\Sigma F_y = 0; \quad F_{AD} = 0 \quad \text{Ans}$$

$$\Sigma F_x = 0; \quad F_{DF} = 0 \quad \text{Ans}$$

$$\Sigma F_z = 0; \quad F_{DE} = 9 \text{ kN (C)} \quad \text{Ans}$$

Joint E :

$$\Sigma F_x = 0; \quad F_{EF} = 0 \quad \text{Ans}$$

$$\Sigma F_y = 0; \quad F_{EA} = 0 \quad \text{Ans}$$

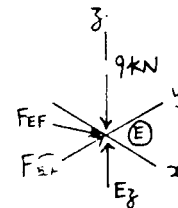

Joint A :

$$\Sigma F_x = 0; \quad F_{AF} = 0 \quad \text{Ans}$$

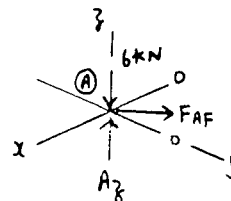

6-66. In each case, determine the force P required to maintain equilibrium. The block weighs 100 lb.

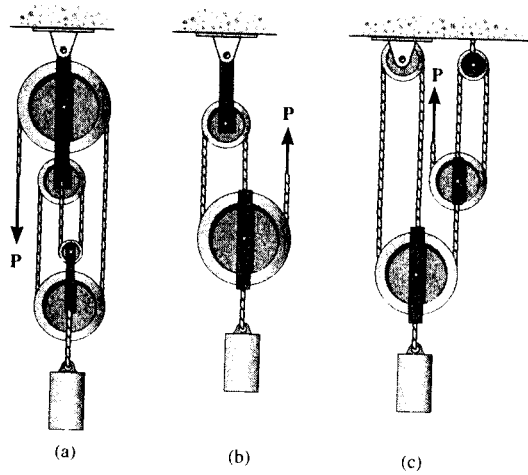

Equations of Equilibrium :

a) $+\uparrow \Sigma F_y = 0; \quad 4P - 100 = 0$
 $P = 25.0 \text{ lb}$

Ans

b) $+\uparrow \Sigma F_y = 0; \quad 3P - 100 = 0$
 $P = 33.3 \text{ lb}$

Ans

c) $+\uparrow \Sigma F_y = 0; \quad 3P' - 100 = 0$
 $P' = 33.33 \text{ lb}$

$+\uparrow \Sigma F_y = 0; \quad 3P - 33.33 = 0$
 $P = 11.1 \text{ lb}$

Ans

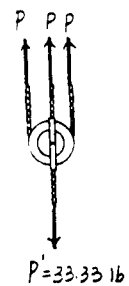
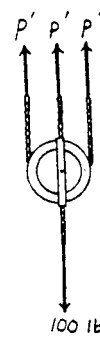

(c)

6-67. The eye hook has a positive locking latch when it supports the load because its two parts are pin-connected at A and they bear against one another along the smooth surface at B . Determine the resultant force at the pin and the normal force at B when the eye hook supports a load of 800 lb.

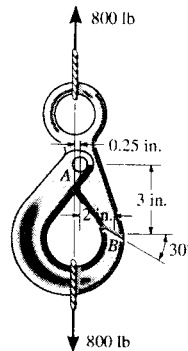

$$\begin{aligned} \curvearrowleft + \Sigma M_A = 0; & \quad - F_B \cos 60^\circ (3) - F_B \sin 60^\circ (2) \\ & \quad + 800(0.25) = 0 \end{aligned}$$

$$F_B = 61.88 = 61.9 \text{ lb} \quad \text{Ans}$$

$$+ \uparrow \Sigma F_y = 0; \quad - 800 - 61.88 \sin 60^\circ + A_y = 0$$

$$A_y = 853.59 = 854 \text{ lb}$$

$$\rightarrow \Sigma F_x = 0; \quad A_x - F_B \cos 60^\circ = 0$$

$$A_x = 30.9 \text{ lb}$$

$$F_A = \sqrt{(853.59)^2 + (30.9)^2}$$

$$= 854 \text{ lb} \quad \text{Ans}$$

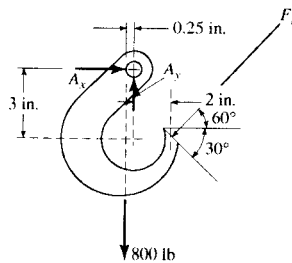

***6-68.** Determine the force P needed to support the 100-lb weight. Each pulley has a weight of 10 lb. Also, what are the cord reactions at A and B ?

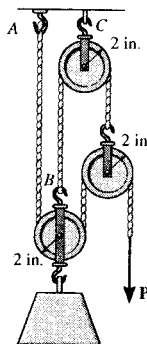

Equations of Equilibrium: From FBD (a),

$$+ \uparrow \Sigma F_y = 0; \quad P' - 2P - 10 = 0 \quad [1]$$

From FBD (b),

$$+ \uparrow \Sigma F_y = 0; \quad 2P + P' - 100 - 10 = 0 \quad [2]$$

Solving Eqs. [1] and [2] yields,

$$P = 25.0 \text{ lb} \quad \text{Ans}$$

$$P' = 60.0 \text{ lb}$$

The cord reactions at A and B are

$$F_A = P = 25.0 \text{ lb} \quad F_B = P' = 60.0 \text{ lb}$$

Ans

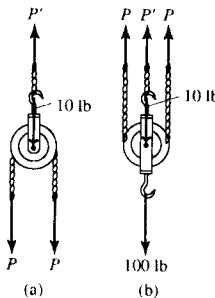

6-69. The link is used to hold the rod in place. Determine the required axial force on the screw at E if the largest force to be exerted on the rod at B , C or D is to be 100 lb. Also, find the magnitude of the force reaction at pin A . Assume all surfaces of contact are smooth.

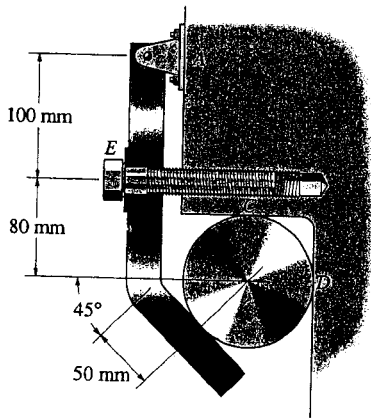

$$\Sigma F_y = 0: \quad R_C = \frac{1}{\sqrt{2}} R_B$$

$$\Sigma F_x = 0: \quad R_D = \frac{1}{\sqrt{2}} R_B$$

Assume $R_B = 100$ lb

$$R_C = R_D = \frac{100}{\sqrt{2}} = 70.71 \text{ lb} < 100 \text{ lb} \quad (\text{O.K.})$$

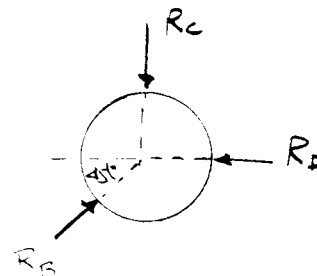

$$(+\Sigma M_A = 0; \quad -100 \sin 45^\circ (50 \sin 45^\circ) - 100 \cos 45^\circ (180 + 50 \cos 45^\circ) + R_E (100) = 0$$

$$R_E = 177.28 = 177 \text{ lb} \quad \text{Ans}$$

$$+\uparrow \Sigma F_y = 0; \quad -100 \sin 45^\circ + A_y = 0$$

$$A_y = 70.71 \text{ lb}$$

$$\rightarrow \Sigma F_x = 0; \quad 177.28 - 100 \cos 45^\circ - A_x = 0$$

$$A_x = 106.57 \text{ lb}$$

$$R_A = \sqrt{106.57^2 + 70.71^2} = 128 \text{ lb} \quad \text{Ans}$$

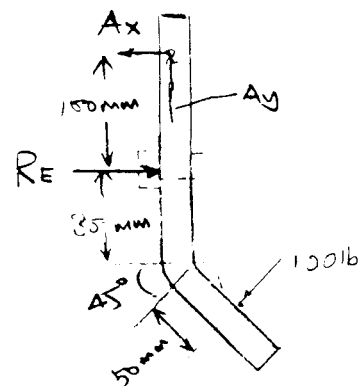

6-70. The principles of a differential chain block are indicated schematically in the figure. Determine the magnitude of force P needed to support the 800-N force. Also, find the distance x where the cable must be attached to bar AB so the bar remains horizontal. All pulleys have a radius of 60 mm.

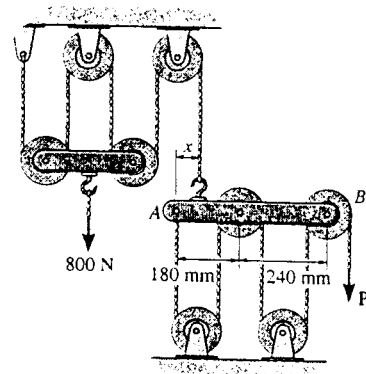

Equations of Equilibrium: From FBD(a),

$$+\uparrow \Sigma F_y = 0; \quad 4P' - 800 = 0 \quad P' = 200 \text{ N}$$

From FBD(b),

$$+\uparrow \Sigma F_y = 0; \quad 200 - 5P = 0 \quad P = 40.0 \text{ N} \quad \text{Ans}$$

$$\begin{aligned} \left(+ \Sigma M_A = 0; \quad 200(x) - 40.0(120) - 40.0(240) \right. \\ \left. - 40.0(360) - 40.0(480) = 0 \right. \end{aligned}$$

$$x = 240 \text{ mm} \quad \text{Ans}$$

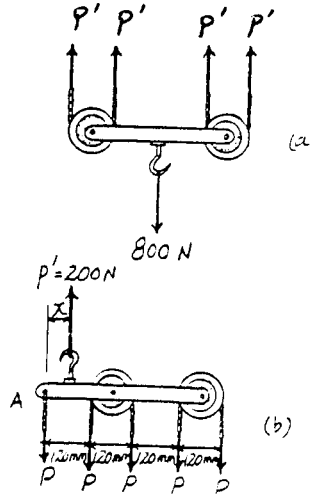

6-71. Determine the force P needed to support the 20-kg mass using the Spanish Burton rig. Also, what are the reactions at the supporting hooks A , B , and C ?

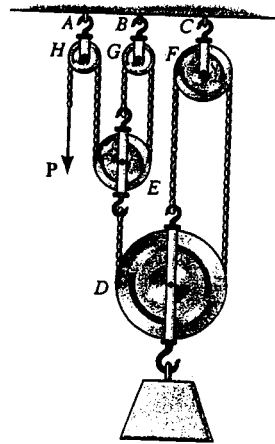

For pulley D :

$$+\uparrow \Sigma F_y = 0; \quad 9P - 20(9.81) = 0$$

$$P = 21.8 \text{ N}$$

At A , $R_A = 2P = 43.6 \text{ N}$

At B , $R_B = 2P = 43.6 \text{ N}$

At C , $R_C = 6P = 131 \text{ N}$

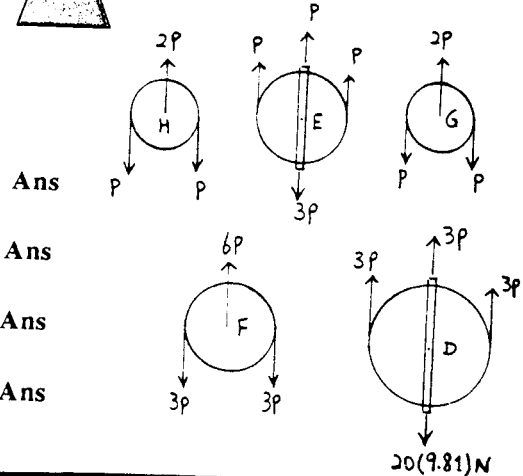

***6-72.** The compound beam is fixed at A and supported by a rocker at B and C . There are hinges (pins) at D and E . Determine the reactions at the supports.

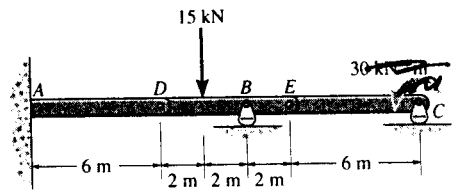

Equations of Equilibrium: From FBD(a),

$$\curvearrowleft + \Sigma M_E = 0; \quad C_y(6) = 0 \quad C_y = 0 \quad \text{Ans}$$

$$+ \uparrow \Sigma F_y = 0; \quad E_y - 0 = 0 \quad E_y = 0$$

$$\rightarrow \Sigma F_x = 0; \quad E_x = 0$$

From FBD(b),

$$\curvearrowleft + \Sigma M_D = 0; \quad B_y(4) - 15(2) = 0$$

$$B_y = 7.50 \text{ kN} \quad \text{Ans}$$

$$+ \uparrow \Sigma F_y = 0; \quad D_y + 7.50 - 15 = 0$$

$$D_y = 7.50 \text{ kN}$$

$$\rightarrow \Sigma F_x = 0; \quad D_x = 0$$

From FBD(c),

$$\curvearrowleft + \Sigma M_A = 0; \quad M_A - 5.00(6) = 0$$

$$M_A = 30.0 \text{ kN} \cdot \text{m} \quad \text{Ans}$$

$$+ \uparrow \Sigma F_y = 0; \quad A_y - 5.00 = 0 \quad A_y = 5.00 \text{ kN} \quad \text{Ans}$$

$$\rightarrow \Sigma F_x = 0; \quad A_x = 0 \quad \text{Ans}$$

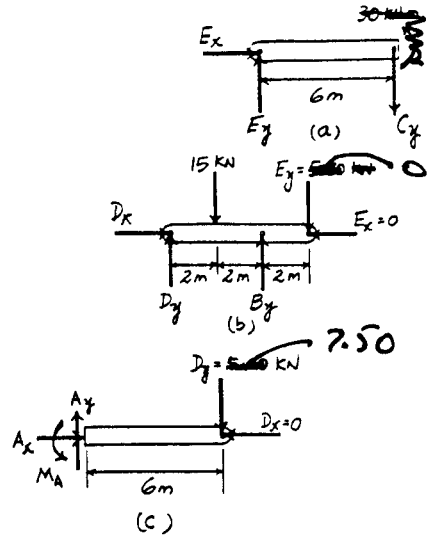

6-73. The compound beam is pin-supported at C and supported by a roller at A and B . There is a hinge (pin) at D . Determine the reactions at the supports. Neglect the thickness of the beam.

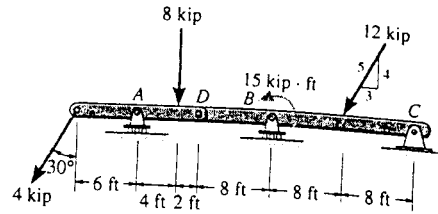

Equations of Equilibrium: From FBD(a),

$$\begin{aligned} \left(+ \Sigma M_D = 0; \quad 4 \cos 30^\circ (12) + 8(2) - A_y (6) = 0 \right. \\ \left. A_y = 9.595 \text{ kip} = 9.59 \text{ kip} \right. \end{aligned} \quad \text{Ans}$$

$$\begin{aligned} + \uparrow \Sigma F_y = 0; \quad D_y + 9.595 - 4 \cos 30^\circ - 8 = 0 \\ D_y = 1.869 \text{ kip} \end{aligned}$$

$$\begin{aligned} \rightarrow \Sigma F_x = 0; \quad D_x - 4 \sin 30^\circ = 0 \quad D_x = 2.00 \text{ kip} \end{aligned}$$

From FBD(b),

$$\begin{aligned} \left(+ \Sigma M_C = 0; \quad 1.869(24) + 15 + 12 \left(\frac{4}{5} \right) (8) - B_y (16) = 0 \right. \\ \left. B_y = 8.541 \text{ kip} = 8.54 \text{ kip} \right. \end{aligned} \quad \text{Ans}$$

$$\begin{aligned} + \uparrow \Sigma F_y = 0; \quad C_y + 8.541 - 1.869 - 12 \left(\frac{4}{5} \right) = 0 \\ C_y = 2.93 \text{ kip} \end{aligned} \quad \text{Ans}$$

$$\begin{aligned} \rightarrow \Sigma F_x = 0; \quad C_x - 2.00 - 12 \left(\frac{3}{5} \right) = 0 \\ C_x = 9.20 \text{ kip} \end{aligned} \quad \text{Ans}$$

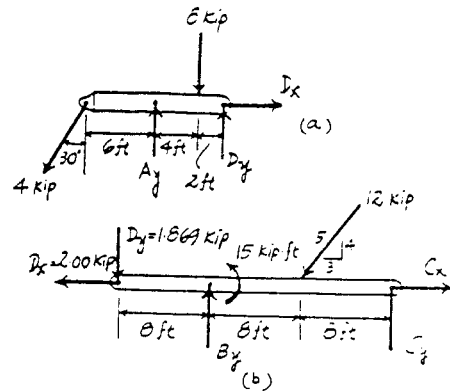

6-74. Determine the greatest force P that can be applied to the frame if the largest force resultant acting at A can have a magnitude of 2 kN.

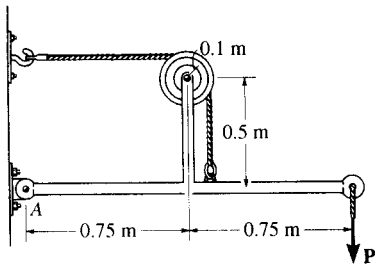

$$+\circlearrowleft \Sigma M_A = 0; \quad T(0.6) - P(1.5) = 0$$

$$\rightarrow \Sigma F_x = 0; \quad A_x - T = 0$$

$$+\uparrow \Sigma F_y = 0; \quad A_y - P = 0$$

$$\text{Thus, } A_x = 2.5P, \quad A_y = P$$

Require.

$$2 = \sqrt{(2.5P)^2 + (P)^2}$$

$$P = 0.743 \text{ kN} = 743 \text{ N} \quad \text{Ans}$$

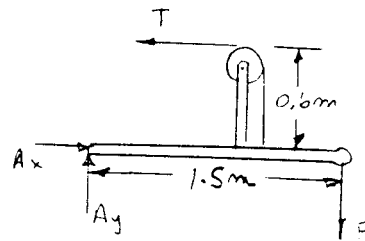

6-75. Determine the horizontal and vertical components force at pins A and C of the two-member frame.

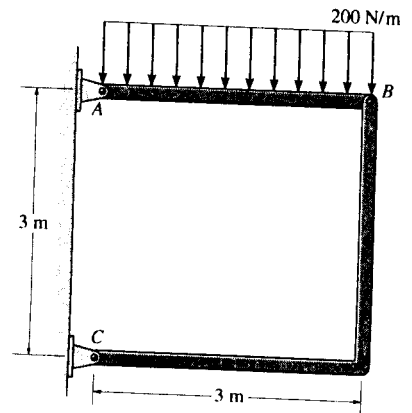

Free Body Diagram : The solution for this problem will be simplified if one realizes that member BC is a two force member.

Equations of Equilibrium :

$$\begin{aligned} \curvearrowright + \Sigma M_A = 0; & \quad F_{BC} \cos 45^\circ (3) - 600(1.5) = 0 \\ & \quad F_{BC} = 424.26 \text{ N} \end{aligned}$$

$$\begin{aligned} + \uparrow \Sigma F_y = 0; & \quad A_y + 424.26 \cos 45^\circ - 600 = 0 \\ & \quad A_y = 300 \text{ N} \end{aligned}$$

Ans

$$\begin{aligned} \rightarrow \Sigma F_x = 0; & \quad 424.26 \sin 45^\circ - A_x = 0 \\ & \quad A_x = 300 \text{ N} \end{aligned}$$

Ans

For pin C ,

$$C_x = F_{BC} \sin 45^\circ = 424.26 \sin 45^\circ = 300 \text{ N} \quad \text{Ans}$$

$$C_y = F_{BC} \cos 45^\circ = 424.26 \cos 45^\circ = 300 \text{ N} \quad \text{Ans}$$

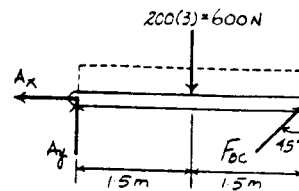

6-76. The three-hinged arch supports the loads $F_1 = 8 \text{ kN}$ and $F_2 = 5 \text{ kN}$. Determine the horizontal and vertical components of reaction at the pin supports A and B . Take $h = 2 \text{ m}$.

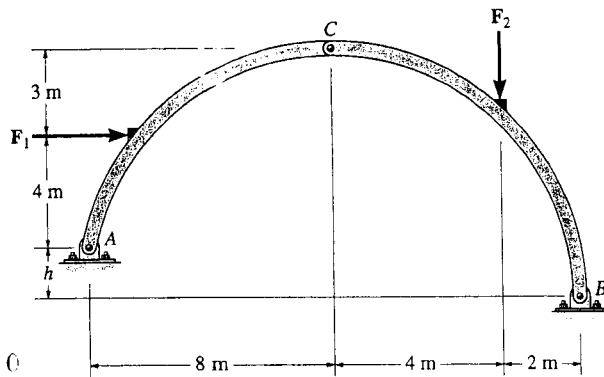

Member AC :

$$\sum M_A = 0; \quad -8(4) + C_y(8) + C_x(7) = 0$$

$$8C_y + 7C_x - 32 = 0$$

$$\rightarrow \Sigma F_x = 0; \quad 8 - A_x - C_x = 0$$

$$+\uparrow \Sigma F_y = 0; \quad -A_y + C_y = 0$$

$$A_y = C_y$$

Member BC :

$$\sum M_B = 0; \quad 5(2) + C_y(6) - C_x(9) = 0$$

$$6C_y - 9C_x + 10 = 0$$

$$\rightarrow \Sigma F_x = 0; \quad C_x - B_x = 0$$

$$B_x = C_x$$

$$+\uparrow \Sigma F_y = 0; \quad -C_y + B_y - 5 = 0$$

Solving:

$$A_x = 5.6141 = 5.61 \text{ kN} \quad \text{Ans}$$

$$A_y = 1.9122 = 1.91 \text{ kN} \quad \text{Ans}$$

$$C_x = 2.3859 = 2.39 \text{ kN} \quad \text{Ans}$$

$$C_y = 1.9122 = 1.91 \text{ kN} \quad \text{Ans}$$

$$B_x = 2.3859 = 2.39 \text{ kN} \quad \text{Ans}$$

$$B_y = 6.9122 = 6.91 \text{ kN} \quad \text{Ans}$$

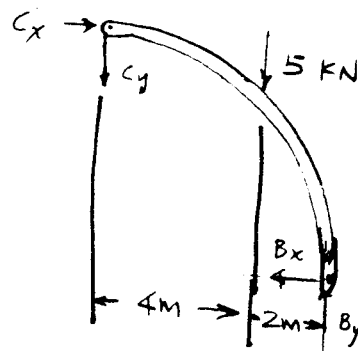
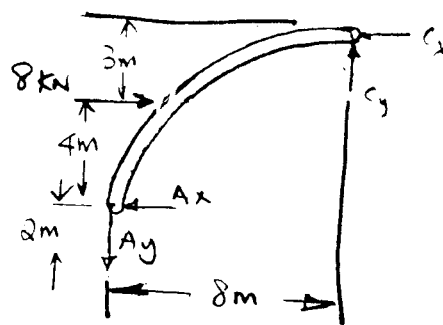
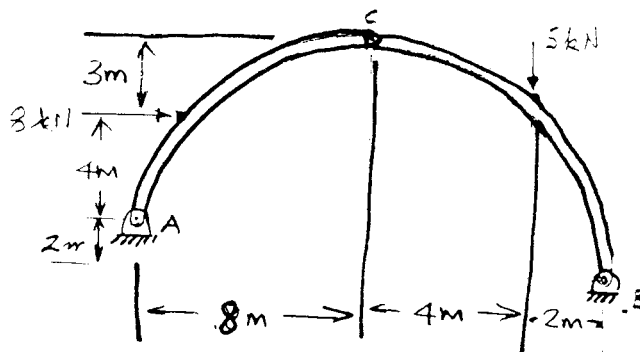

6-77. Determine the horizontal and vertical components of force at pins A , B , and C , and the reactions to the fixed support D of the three-member frame.

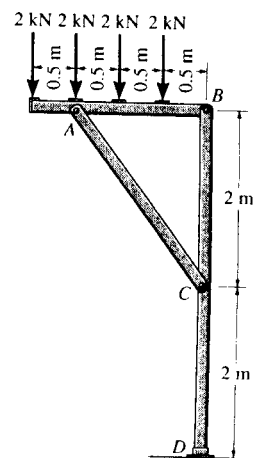

Free Body Diagram: The solution for this problem will be simplified if one realizes that member AC is a two force member.

Equations of Equilibrium: For FBD(a),

$$\begin{aligned} \curvearrowright + \Sigma M_B = 0; & \quad 2(0.5) + 2(1) + 2(1.5) + 2(2) - F_{AC} \left(\frac{4}{5}\right)(1.5) = 0 \\ & \quad F_{AC} = 8.333 \text{ kN} \end{aligned}$$

$$\begin{aligned} + \uparrow \Sigma F_y = 0; & \quad B_y + 8.333 \left(\frac{4}{5}\right) - 2 - 2 - 2 - 2 = 0 \\ & \quad B_y = 1.333 \text{ kN} = 1.33 \text{ kN} \quad \text{Ans} \end{aligned}$$

$$\begin{aligned} \rightarrow \Sigma F_x = 0; & \quad B_x - 8.333 \left(\frac{3}{5}\right) = 0 \\ & \quad B_x = 5.00 \text{ kN} \quad \text{Ans} \end{aligned}$$

For pin A and C ,

$$A_x = C_x = F_{AC} \left(\frac{3}{5}\right) = 8.333 \left(\frac{3}{5}\right) = 5.00 \text{ kN} \quad \text{Ans}$$

$$A_y = C_y = F_{AC} \left(\frac{4}{5}\right) = 8.333 \left(\frac{4}{5}\right) = 6.67 \text{ kN} \quad \text{Ans}$$

From FBD (b),

$$\begin{aligned} \curvearrowright + \Sigma M_D = 0; & \quad 5.00(4) - 8.333 \left(\frac{3}{5}\right)(2) - M_D = 0 \\ & \quad M_D = 10.0 \text{ kN} \cdot \text{m} \quad \text{Ans} \end{aligned}$$

$$\begin{aligned} + \uparrow \Sigma F_y = 0; & \quad D_y - 1.333 - 8.333 \left(\frac{4}{5}\right) = 0 \\ & \quad D_y = 8.00 \text{ kN} \quad \text{Ans} \end{aligned}$$

$$\begin{aligned} \rightarrow \Sigma F_x = 0; & \quad 8.333 \left(\frac{3}{5}\right) - 5.00 - D_x = 0 \\ & \quad D_x = 0 \quad \text{Ans} \end{aligned}$$

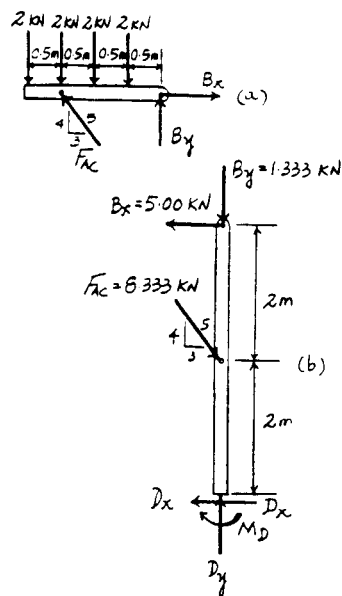

6-78. Determine the horizontal and vertical components of force at C which member ABC exerts on member CEF.

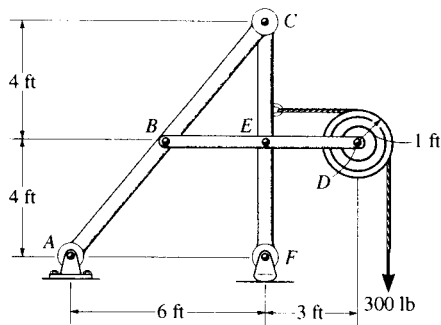

Member BED :

$$(+\Sigma M_B = 0; \quad -300(6) + E_y(3) = 0$$

$$E_y = 600 \text{ lb}$$

$$+\uparrow \Sigma F_y = 0; \quad -B_y + 600 - 300 = 0$$

$$B_y = 300 \text{ lb}$$

$$\rightarrow \Sigma F_x = 0; \quad B_x + E_x - 300 = 0$$

Member FEC :

$$(+\Sigma M_C = 0; \quad 300(3) - E_x(4) = 0$$

$$E_x = 225 \text{ lb}$$

From Eq. (1) $B_x = 75 \text{ lb}$

$$\rightarrow \Sigma F_x = 0; \quad -C_x + 300 - 225 = 0$$

$$C_x = 75 \text{ lb} \quad \text{Ans}$$

Member ABC :

$$(+\Sigma M_A = 0; \quad -75(8) - C_y(6) + 75(4) + 300(3) = 0$$

$$C_y = 100 \text{ lb} \quad \text{Ans}$$

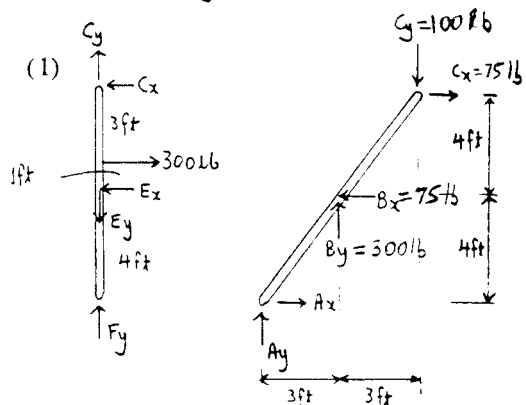
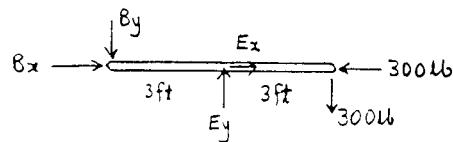
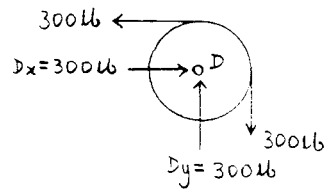

6-79. Determine the horizontal and vertical components of force that the pins at A, B, and C exert on their connecting members.

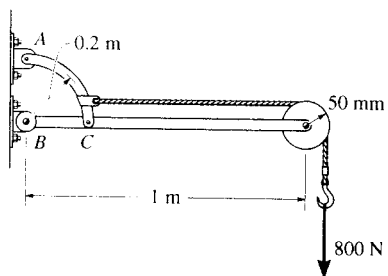

$$\curvearrowleft + \Sigma M_B = 0; \quad -800(1 + 0.05) + A_x(0.2) = 0$$

$$A_x = 4200 \text{ N} = 4.20 \text{ kN}$$

$$\rightarrow \Sigma F_x = 0; \quad B_x = 4200 \text{ N} = 4.20 \text{ kN}$$

$$+\uparrow \Sigma F_y = 0; \quad A_y - B_y - 800 = 0 \quad (1)$$

Member AC:

$$\curvearrowleft + \Sigma M_C = 0; \quad -800(50) - A_y(200) + 4200(200) = 0$$

$$A_y = 4000 \text{ N} = 4.00 \text{ kN} \quad \text{Ans}$$

From Eq. (1) $B_y = 3.20 \text{ kN} \quad \text{Ans}$

$$\rightarrow \Sigma F_x = 0; \quad -4200 + 800 + C_x = 0$$

$$C_x = 3.40 \text{ kN} \quad \text{Ans}$$

$$+\uparrow \Sigma F_y = 0; \quad 4000 - C_y = 0$$

$$C_y = 4.00 \text{ kN} \quad \text{Ans}$$

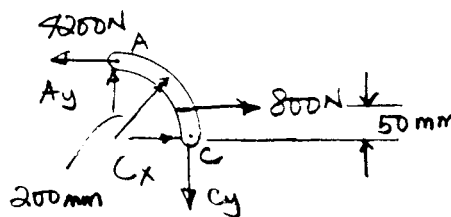
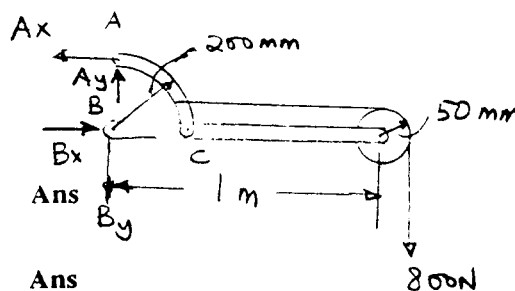

*6-80. The hoist supports the 125-kg engine. Determine the force the load creates in member DB and in member FB , which contains the hydraulic cylinder H .

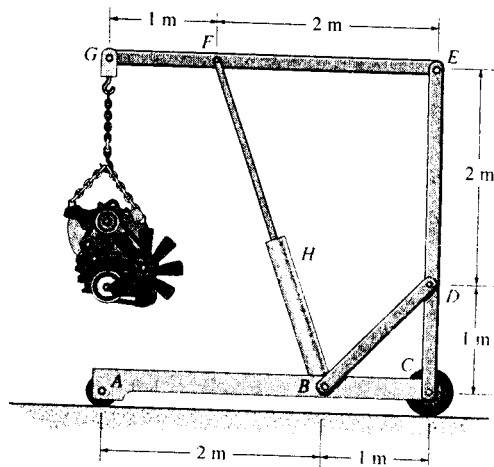

Free Body Diagram : The solution for this problem will be simplified if one realizes that members FB and DB are two force members.

Equations of Equilibrium : For FBD(a),

$$\begin{aligned} \sum M_E = 0; \quad 1226.25(3) - F_{FB} \left(\frac{3}{\sqrt{10}} \right) (2) &= 0 \\ F_{FB} &= 1938.87 \text{ N} = 1.94 \text{ kN} \quad \text{Ans} \end{aligned}$$

$$\begin{aligned} + \uparrow \sum F_y = 0; \quad 1938.87 \left(\frac{3}{\sqrt{10}} \right) - 1226.25 - E_y &= 0 \\ E_y &= 613.125 \text{ N} \end{aligned}$$

$$\begin{aligned} \rightarrow \sum F_x = 0; \quad E_x - 1938.87 \left(\frac{1}{\sqrt{10}} \right) &= 0 \\ E_x &= 613.125 \text{ N} \end{aligned}$$

From FBD (b),

$$\begin{aligned} \sum M_C = 0; \quad 613.125(3) - F_{DB} \sin 45^\circ (1) &= 0 \\ F_{DB} &= 2601.27 \text{ N} = 2.60 \text{ kN} \quad \text{Ans} \end{aligned}$$

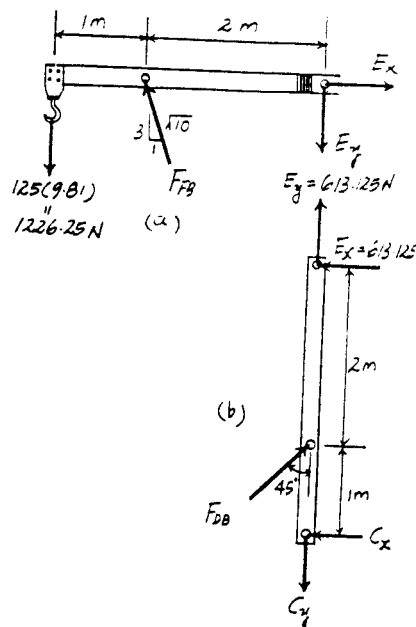

6-81. Determine the force P on the cord, and the angle θ that the pulley-supporting link AB makes with the vertical. Neglect the mass of the pulleys and the link. The block has a weight of 200 lb and the cord is attached to the pin at B . The pulleys have radii of $r_1 = 2$ in. and $r_2 = 1$ in.

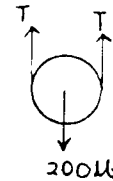
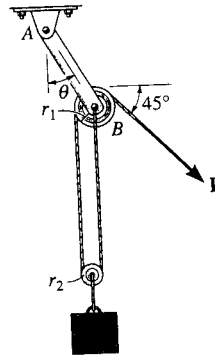

$$+\uparrow \Sigma F_y = 0; \quad 2T - 200 = 0$$

$$T = 100 \text{ lb} \quad \text{Ans}$$

$$\rightarrow \Sigma F_x = 0; \quad 100 \cos 45^\circ - F_{AB} \sin \theta = 0$$

$$+\uparrow \Sigma F_y = 0; \quad F_{AB} \cos \theta - 100 - 100 - 100 \sin 45^\circ = 0$$

$$\theta = 14.6^\circ \quad \text{Ans}$$

$$F_{AB} = 280 \text{ lb}$$

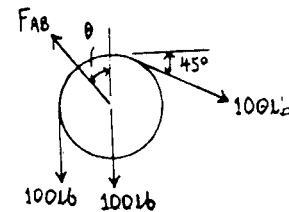

6-82. The front of the car is to be lifted using a smooth, rigid 10-ft long board. The car has a weight of 3500 lb and a center of gravity at G . Determine the position x of the fulcrum so that an applied force of 100 lb at E will lift the front wheels of the car.

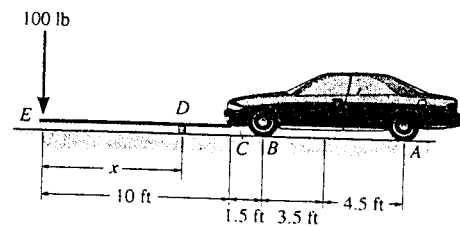

Free Body Diagram : When the front wheels are lifted, the normal reaction $N_B = 0$.

Equations of Equilibrium : From FBD (a),

$$(+\Sigma M_A = 0; \quad 3500(4.5) - F_C(9.5) = 0 \quad F_C = 1657.89 \text{ lb}$$

From FBD (b),

$$(+\Sigma M_D = 0; \quad 100(x) - 1657.89(10 - x) = 0$$

$$x = 9.43 \text{ ft} \quad \text{Ans}$$

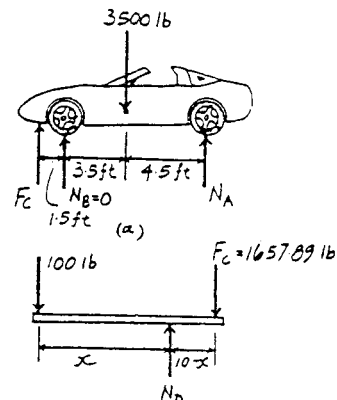

6-83. The wall crane supports a load of 700 lb. Determine the horizontal and vertical components of reaction at the pins A and D . Also, what is the force in the cable at the winch W ?

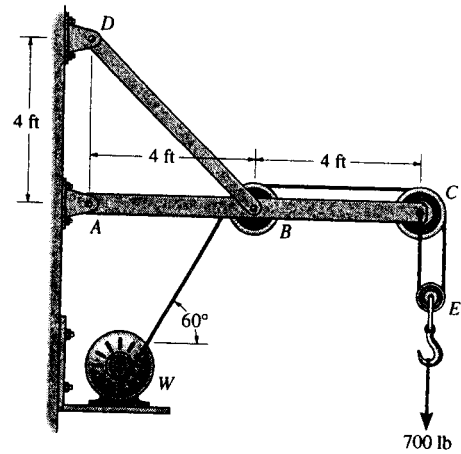

Pulley E :

$$+\uparrow \Sigma F_y = 0; \quad 2T - 700 = 0$$

$$T = 350 \text{ lb} \quad \text{Ans}$$

Member ABC :

$$\curvearrowleft + \Sigma M_A = 0; \quad T_{BD} \sin 45^\circ (4) - 350 \sin 60^\circ (4) - 700 (8) = 0$$

$$T_{BD} = 2409 \text{ lb}$$

$$+\uparrow \Sigma F_y = 0; \quad -A_y + 2409 \sin 45^\circ - 350 \sin 60^\circ - 700 = 0$$

$$A_y = 700 \text{ lb} \quad \text{Ans}$$

$$\rightarrow \Sigma F_x = 0; \quad A_x - 2409 \cos 45^\circ - 350 \cos 60^\circ + 350 - 350 = 0$$

$$A_x = 1.88 \text{ kip} \quad \text{Ans}$$

At D :

$$D_x = 2409 \cos 45^\circ = 1703.1 \text{ lb} = 1.70 \text{ kip} \quad \text{Ans}$$

$$D_y = 2409 \sin 45^\circ = 1.70 \text{ kip} \quad \text{Ans}$$

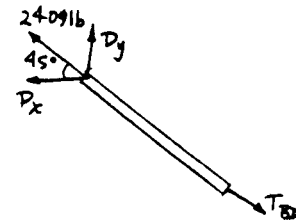
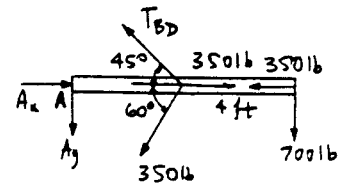
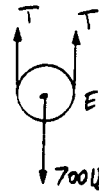

***6-84.** Determine the force that the smooth roller C exerts on beam AB . Also, what are the horizontal and vertical components of reaction at pin A ? Neglect the weight of the frame and roller.

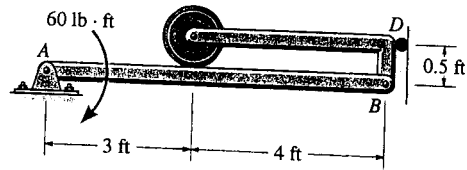

$$\curvearrowleft + \Sigma M_A = 0; \quad -60 + D_x(0.5) = 0$$

$$D_x = 120 \text{ lb}$$

$$\rightarrow + \Sigma F_x = 0; \quad A_x = 120 \text{ lb} \quad \text{Ans}$$

$$+ \uparrow \Sigma F_y = 0; \quad A_y = 0 \quad \text{Ans}$$

$$\curvearrowleft + \Sigma M_B = 0; \quad -N_C(4) + 120(0.5) = 0$$

$$N_C = 15.0 \text{ lb} \quad \text{Ans}$$

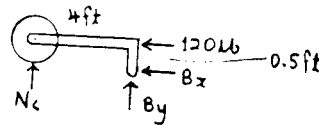
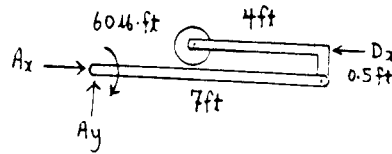

6-85. Determine the horizontal and vertical components of force which the pins exert on member ABC .

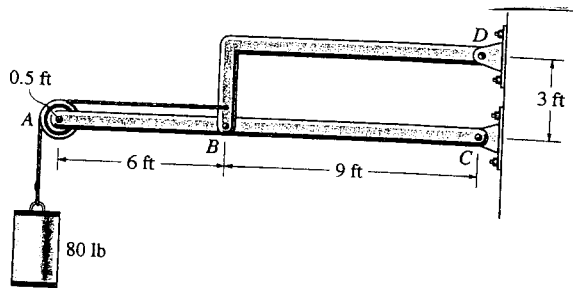

$$\rightarrow + \Sigma F_x = 0; \quad A_x = 80 \text{ lb} \quad \text{Ans}$$

$$+ \uparrow \Sigma F_y = 0; \quad A_y = 80 \text{ lb} \quad \text{Ans}$$

$$\curvearrowleft + \Sigma M_C = 0; \quad 80(15) - B_y(9) = 0$$

$$B_y = 133.3 = 133 \text{ lb} \quad \text{Ans}$$

$$\curvearrowleft + \Sigma M_D = 0; \quad -80(2.5) + 133.3(9) - B_x(3) = 0$$

$$B_x = 333 \text{ lb} \quad \text{Ans}$$

$$\rightarrow + \Sigma F_x = 0; \quad 80 + 333 - C_x = 0$$

$$C_x = 413 \text{ lb} \quad \text{Ans}$$

$$+ \uparrow \Sigma F_y = 0; \quad -80 + 133.3 - C_y = 0$$

$$C_y = 53.3 \text{ lb} \quad \text{Ans}$$

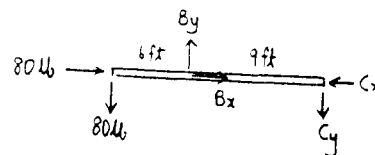
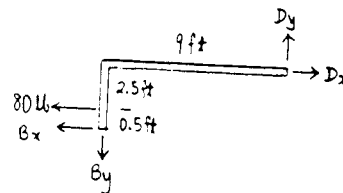
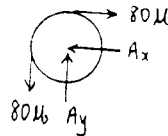

6-86. The engine hoist is used to support the 200-kg engine. Determine the force acting in the hydraulic cylinder AB , the horizontal and vertical components of force at the pin C , and the reactions at the fixed support D .

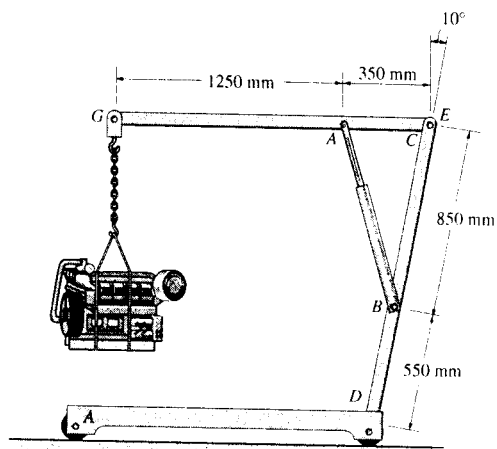

Free Body Diagram : The solution for this problem will be simplified if one realizes that member AB is a two force member. From the geometry,

$$l_{AB} = \sqrt{350^2 + 850^2 - 2(350)(850)\cos 80^\circ} = 861.21 \text{ mm}$$

$$\frac{\sin \theta}{850} = \frac{\sin 80^\circ}{861.21} \quad \theta = 76.41^\circ$$

Equations of Equilibrium : From FBD (a),

$$\begin{aligned} +\Sigma M_C = 0; \quad & 1962(1.60) - F_{AB} \sin 76.41^\circ(0.35) = 0 \\ & F_{AB} = 9227.60 \text{ N} = 9.23 \text{ kN} \end{aligned} \quad \text{Ans}$$

$$\begin{aligned} \rightarrow \Sigma F_x = 0; \quad & C_x - 9227.60 \cos 76.41^\circ = 0 \\ & C_x = 2168.65 \text{ N} = 2.17 \text{ kN} \end{aligned} \quad \text{Ans}$$

$$\begin{aligned} +\uparrow \Sigma F_y = 0; \quad & 9227.60 \sin 76.41^\circ - 1962 - C_y = 0 \\ & C_y = 7007.14 \text{ N} = 7.01 \text{ kN} \end{aligned} \quad \text{Ans}$$

From FBD (b),

$$\rightarrow \Sigma F_x = 0; \quad D_x = 0 \quad \text{Ans}$$

$$\begin{aligned} +\uparrow \Sigma F_y = 0; \quad & D_y - 1962 = 0 \\ & D_y = 1962 \text{ N} = 1.96 \text{ kN} \end{aligned} \quad \text{Ans}$$

$$\begin{aligned} +\Sigma M_D = 0; \quad & 1962(1.60 - 1.40 \sin 10^\circ) - M_D = 0 \\ & M_D = 2662.22 \text{ N} \cdot \text{m} = 2.66 \text{ kN} \cdot \text{m} \end{aligned} \quad \text{Ans}$$

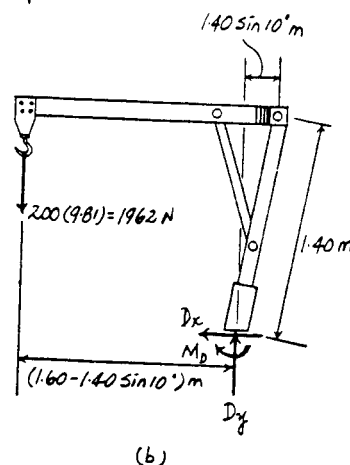
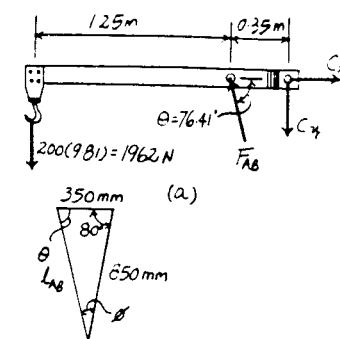

6-87. Determine the horizontal and vertical components of force at pins B and C .

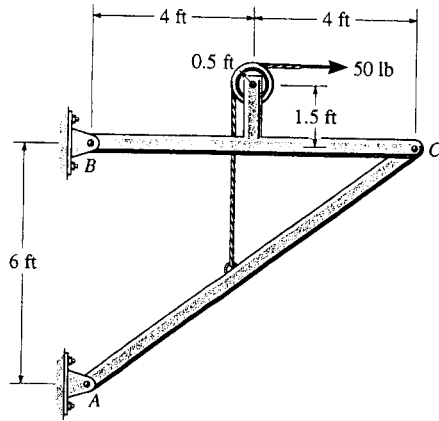

$$\sum M_A = 0; \quad -C_y(8) + C_x(6) + 50(3.5) = 0$$

$$\sum F_x = 0; \quad A_x = C_x$$

$$\sum F_y = 0; \quad 50 - A_y - C_y = 0$$

$$\sum M_B = 0; \quad -50(2) - 50(3.5) + C_y(8) = 0$$

$$C_y = 34.38 = 34.4 \text{ lb} \quad \text{Ans}$$

$$C_x = 16.67 = 16.7 \text{ lb} \quad \text{Ans}$$

$$\sum F_x = 0; \quad 16.67 + 50 - B_x = 0$$

$$B_x = 66.7 \text{ lb} \quad \text{Ans}$$

$$\sum F_y = 0; \quad B_y - 50 + 34.38 = 0$$

$$B_y = 15.6 \text{ lb} \quad \text{Ans}$$

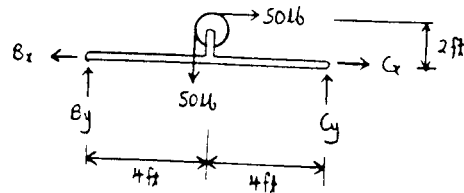
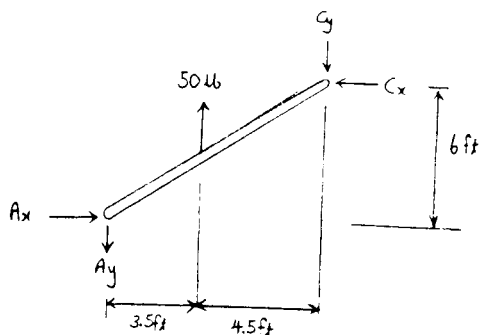

*6-88. The pipe cutter is clamped around the pipe P . If the wheel at A exerts a normal force of $F_A = 80$ N on the pipe, determine the normal forces of wheels B and C on the pipe. Also compute the pin reaction on the wheel at C . The three wheels each have a radius of 7 mm and the pipe has an outer radius of 10 mm.

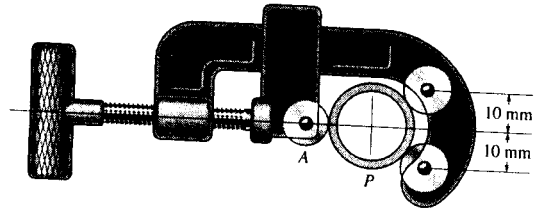

$$\theta = \sin^{-1}\left(\frac{10}{17}\right) = 36.03^\circ$$

Equations of Equilibrium:

$$\begin{aligned}
 + \uparrow \Sigma F_y = 0; & \quad N_B \sin 36.03^\circ - N_C \sin 36.03^\circ = 0 \\
 & \quad N_B = N_C \\
 \rightarrow \Sigma F_x = 0; & \quad 80 - N_C \cos 36.03^\circ - N_C \cos 36.03^\circ = 0 \\
 & \quad N_B = N_C = 49.5 \text{ N} \quad \text{Ans}
 \end{aligned}$$

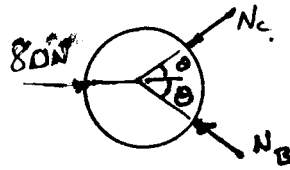

6-89. Determine the horizontal and vertical components of force at each pin. The suspended cylinder has a weight of 80 lb.

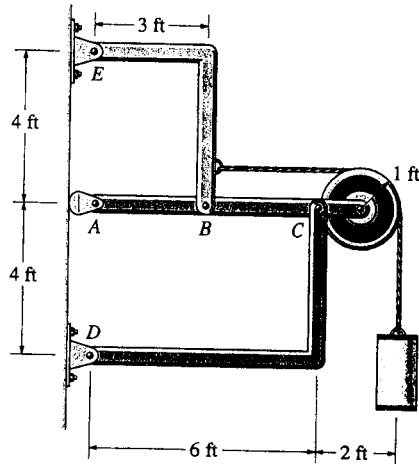

$$\curvearrow + \Sigma M_B = 0; \quad F_{CD} \left(\frac{2}{\sqrt{13}} \right) (3) - 80(4) = 0$$

$$F_{CD} = 192.3 \text{ lb}$$

$$C_x = D_x = \frac{3}{\sqrt{13}} (192.3) = 160 \text{ lb} \quad \text{Ans}$$

$$C_y = D_y = \frac{2}{\sqrt{13}} (192.3) = 107 \text{ lb} \quad \text{Ans}$$

$$+ \uparrow \Sigma F_y = 0; \quad -B_y + \frac{2}{\sqrt{13}} (192.3) - 80 = 0$$

$$B_y = 26.7 \text{ lb}$$

$$\curvearrow + \Sigma M_E = 0; \quad -B_x(4) + 80(3) + 26.7(3) = 0$$

$$B_x = 80.0 \text{ lb} \quad \text{Ans}$$

$$\rightarrow \Sigma F_x = 0; \quad E_x + 80 - 80 = 0$$

$$E_x = 0 \quad \text{Ans}$$

$$+ \uparrow \Sigma F_y = 0; \quad -E_y + 26.7 = 0$$

$$E_y = 26.7 \text{ lb} \quad \text{Ans}$$

$$\rightarrow \Sigma F_x = 0; \quad -A_x + 80 + \frac{3}{\sqrt{13}} (192.3) - 80 = 0$$

$$A_x = 160 \text{ lb} \quad \text{Ans}$$

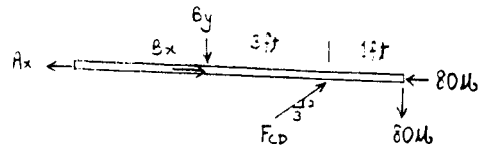

Ans

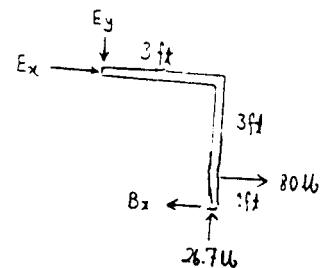

6-90. The toggle clamp is subjected to a force F at the handle. Determine the vertical clamping force acting at E .

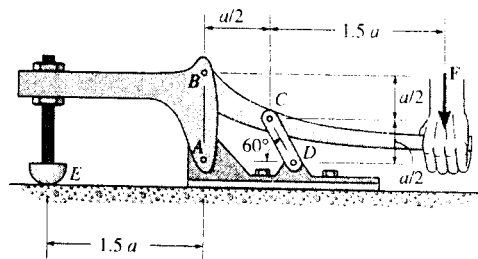

Free Body Diagram : The solution for this problem will be simplified if one realizes that member CD is a two force member.

Equations of Equilibrium : From FBD (a),

$$\left(+ \Sigma M_B = 0; \quad F_{CD} \cos 30^\circ \left(\frac{a}{2} \right) - F_{CD} \sin 30^\circ \left(\frac{a}{2} \right) - F(2a) = 0 \right. \\ \left. F_{CD} = 10.93F \right.$$

$$+ \uparrow \Sigma F_y = 0; \quad 10.93F \cos 30^\circ - F - B_y = 0 \\ B_y = 8.464F$$

$$\rightarrow \Sigma F_x = 0; \quad B_x - 10.93 \sin 30^\circ = 0 \\ B_x = 5.464F$$

From (b),

$$\left(+ \Sigma M_A = 0; \quad 5.464F(a) - F_E(1.5a) = 0 \right. \\ \left. F_E = 3.64F \right.$$

Ans

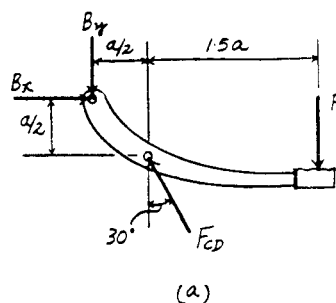

(a)

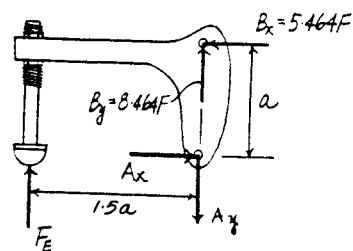

(b)

6-91. Determine the horizontal and vertical components of force which the pins at A, B, and C exert on member ABC of the frame.

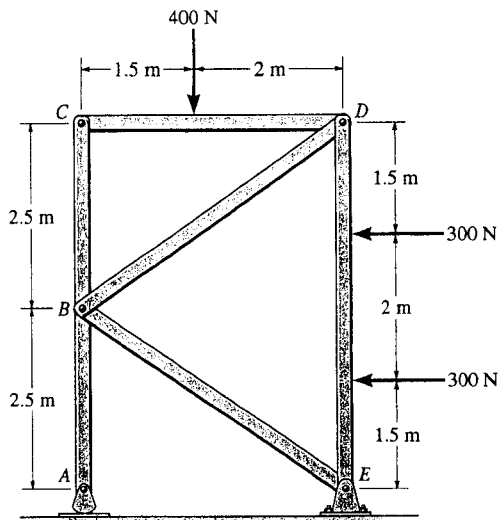

$$\curvearrowleft + \Sigma M_E = 0; \quad -A_y(3.5) + 400(2) + 300(3.5) + 300(1.5) = 0$$

$$A_y = 657.1 = 657 \text{ N} \quad \text{Ans}$$

$$\curvearrowleft + \Sigma M_D = 0; \quad -C_y(3.5) + 400(2) = 0$$

$$C_y = 228.6 = 229 \text{ N} \quad \text{Ans}$$

$$\curvearrowleft + \Sigma M_B = 0; \quad C_x = 0 \quad \text{Ans}$$

$$\rightarrow \Sigma F_x = 0; \quad F_{BD} = F_{BE}$$

$$+ \uparrow \Sigma F_y = 0; \quad 657.1 - 228.6 - 2\left(\frac{5}{\sqrt{74}}\right)F_{BD} = 0$$

$$F_{BD} = F_{BE} = 368.7 \text{ N}$$

$$B_x = 0 \quad \text{Ans}$$

$$B_y = \frac{5}{\sqrt{74}}(368.7)(2) = 429 \text{ N} \quad \text{Ans}$$

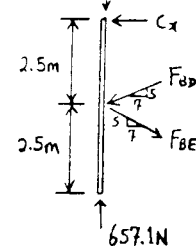
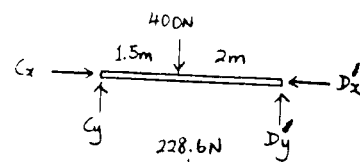
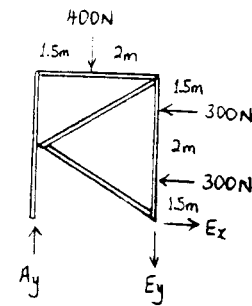

*6-92. The derrick is pin-connected to the pivot at A . Determine the largest mass that can be supported by the derrick if the maximum force that can be sustained by the pin at A is 18 kN.

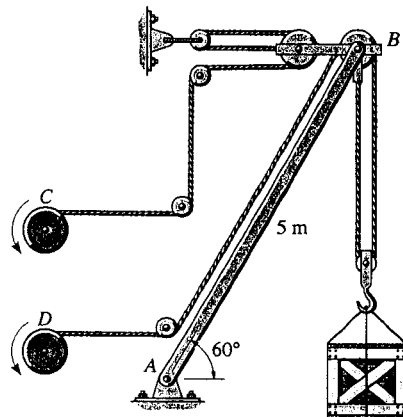

AB is a two-force member.

Pin B

Require $F_{AB} = 18 \text{ kN}$

$$+\uparrow \Sigma F_y = 0; \quad 18 \sin 60^\circ - \frac{W}{2} \sin 60^\circ - W = 0$$

$$W = 10.878 \text{ kN}$$

$$m = \frac{10.878}{9.81} = 1.11 \text{ Mg} \quad \text{Ans}$$

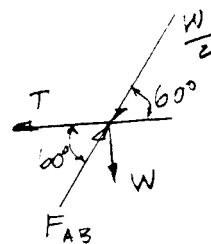

6-93. Determine the required mass of the suspended cylinder if the tension in the chain wrapped around the freely turning gear is to be 2 kN. Also, what is the magnitude of the resultant force on pin A?

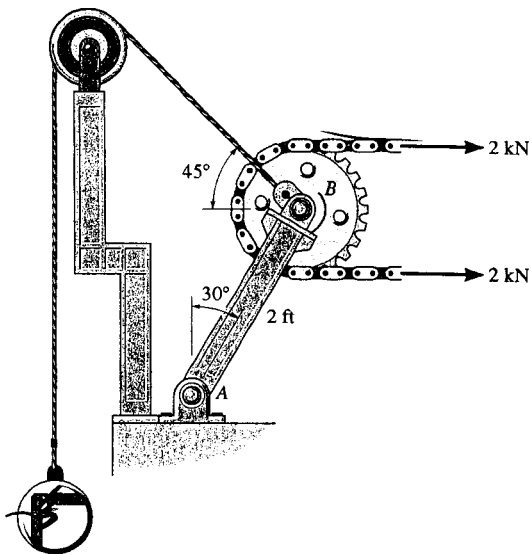

$$+\circlearrowleft \Sigma M_A = 0; \quad -4(2 \cos 30^\circ) + W \cos 45^\circ(2 \cos 30^\circ) + W \sin 45^\circ(2 \sin 30^\circ) = 0$$

$$W = 3.586 \text{ kN}$$

$$m = 3.586(1000)/9.81 = 366 \text{ kg} \quad \text{Ans}$$

$$\rightarrow \Sigma F_x = 0; \quad 4 - 3.586 \cos 45^\circ - A_x = 0$$

$$A_x = 1.464 \text{ kN}$$

$$+\uparrow \Sigma F_y = 0; \quad 3.586 \sin 45^\circ - A_y = 0$$

$$A_y = 2.536 \text{ kN}$$

$$F_A = \sqrt{(1.464)^2 + (2.536)^2} = 2.93 \text{ kN} \quad \text{Ans}$$

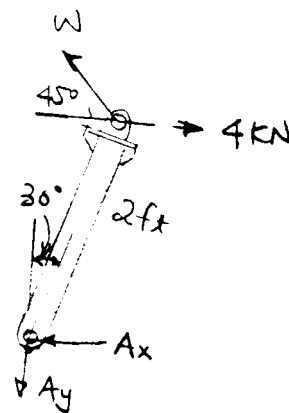

6-94. The pumping unit is used to recover oil. When the walking beam ABC is horizontal, the force acting in the wireline at the well head is 250 lb. Determine the torque M which must be exerted by the motor in order to overcome this load. The horse-head C weighs 60 lb and has a center of gravity at G_C . The walking beam ABC has a weight of 130 lb and a center of gravity at G_B , and the counterweight has a weight of 200 lb and a center of gravity at G_W . The pitman, AD , is pin-connected at its ends and has negligible weight.

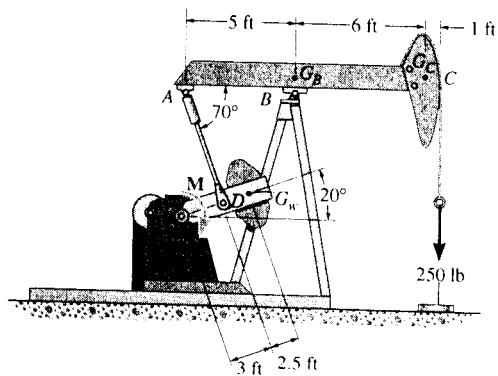

Free Body Diagram : The solution for this problem will be simplified if one realizes that the pitman AD is a two force member.

Equations of Equilibrium : From FBD (a),

$$\begin{aligned} \sum M_B = 0; & \quad F_{AD} \sin 70^\circ (5) - 60(6) - 250(7) = 0 \\ & \quad F_{AD} = 449.08 \text{ lb} \end{aligned}$$

From (b),

$$\begin{aligned} \sum M_E = 0; & \quad 449.08(3) - 200 \cos 20^\circ (5.5) - M = 0 \\ & \quad M = 314 \text{ lb} \cdot \text{ft} \quad \text{Ans} \end{aligned}$$

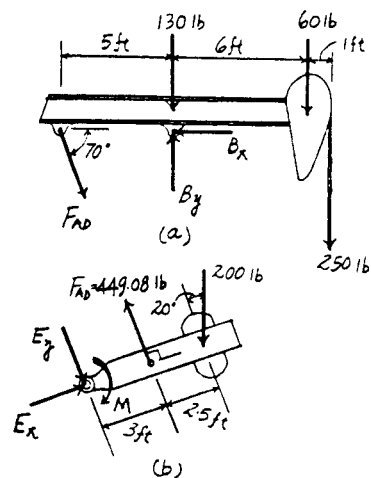

6-95. Determine the force P on the cable if the spring is compressed 0.5 in. when the mechanism is in the position shown. The spring has a stiffness of $k = 800$ lb/ft.

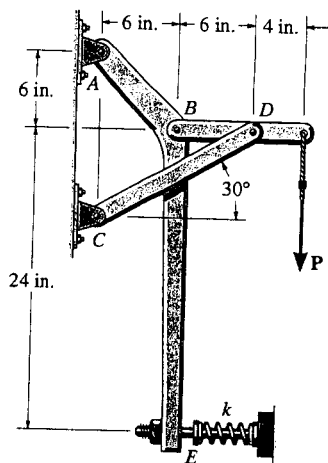

Prob. 6-95

$$F_E = ks = 800\left(\frac{0.5}{12}\right) = 33.33 \text{ lb}$$

$$\curvearrowleft + \Sigma M_A = 0; \quad B_x(6) + B_y(6) - 33.33(30) = 0$$

$$B_x + B_y = 166.67 \text{ lb} \quad (1)$$

$$\curvearrowleft + \Sigma M_D = 0; \quad B_y(6) - P(4) = 0$$

$$B_y = 0.6667P \quad (2)$$

$$\rightarrow \Sigma F_x = 0; \quad -B_x + F_{CD} \cos 30^\circ = 0 \quad (3)$$

$$\curvearrowleft + \Sigma M_B = 0; \quad F_{CD} \sin 30^\circ(6) - P(10) = 0$$

$$F_{CD} = 3.333P$$

Thus from Eq. (3)

$$B_x = 2.8867P$$

Using Eqs. (1) and (2) :

$$2.8867P + 0.6667P = 166.67$$

$$P = 46.9 \text{ lb} \quad \text{Ans}$$

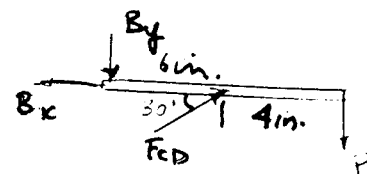
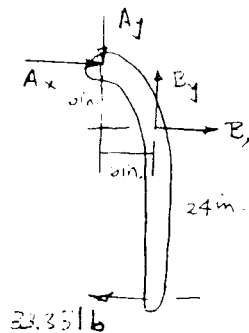

*6-96. Determine the force that the jaws *J* of the metal cutters exert on the smooth cable *C* if 100-N forces are applied to the handles. The jaws are pinned at *E* and *A*, and *D* and *B*. There is also a pin at *F*.

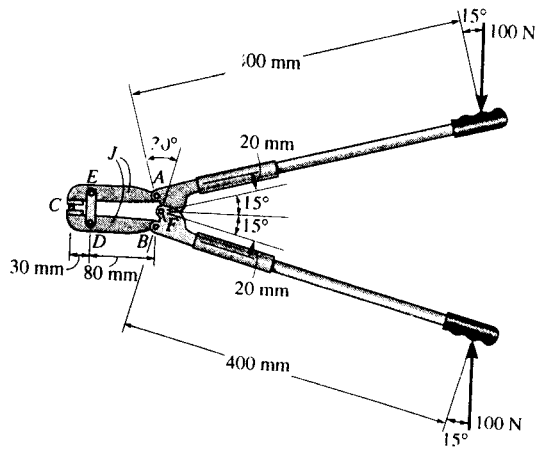

Free Body Diagram : The solution for this problem will be simplified if one realizes that member *ED* is a two force member.

Equations of Equilibrium : From FBD (b),

$$\rightarrow \Sigma F_x = 0; \quad A_x = 0$$

From (a),

$$\begin{aligned} (+\Sigma M_F = 0; \quad & A_y \sin 15^\circ (20) + 100 \sin 15^\circ (20) \\ & - 100 \cos 15^\circ (400) = 0 \\ & A_y = 7364.10 \text{ N} \end{aligned}$$

From FBD (b),

$$\begin{aligned} (+\Sigma M_E = 0; \quad & 7364.10(80) - F_C(30) = 0 \\ & F_C = 19637.60 \text{ N} = 19.6 \text{ kN} \quad \text{Ans} \end{aligned}$$

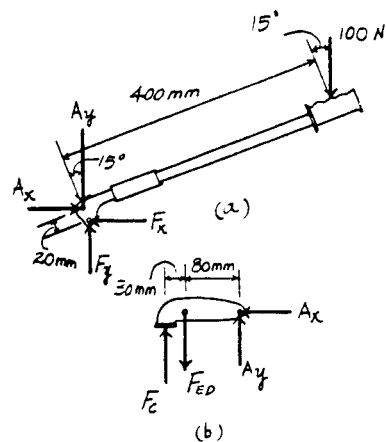

6-97. The compound arrangement of the pan scale is shown. If the mass on the pan is 4 kg, determine the horizontal and vertical components at pins A, B, and C and the distance x of the 25-g mass to keep the scale in balance.

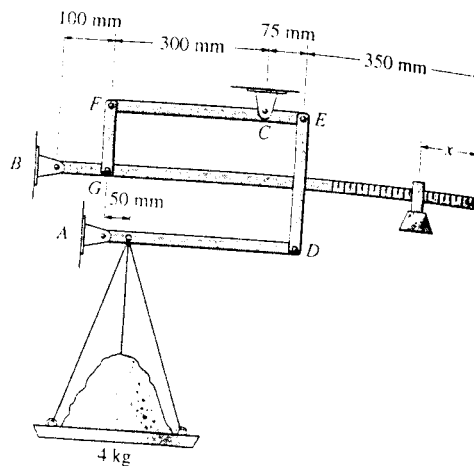

Free Body Diagram: The solution for this problem will be simplified if one realizes that members *DE* and *FG* are two force members.

Equations of Equilibrium: From FBD (a),

$$\curvearrowleft + \Sigma M_A = 0: \quad F_{DE}(375) - 39.24(50) = 0 \quad F_{DE} = 5.232 \text{ N}$$

$$+ \uparrow \Sigma F_y = 0: \quad A_y + 5.232 - 39.24 = 0$$

$$A_y = 34.0 \text{ N} \quad \text{Ans}$$

$$\rightarrow \Sigma F_x = 0: \quad A_x = 0 \quad \text{Ans}$$

From (b),

$$\curvearrowleft + \Sigma M_C = 0: \quad F_{FG}(300) - 5.232(75) = 0 \quad F_{FG} = 1.308 \text{ N}$$

$$+ \uparrow \Sigma F_y = 0: \quad C_y - 1.308 - 5.232 = 0$$

$$C_y = 6.54 \text{ N} \quad \text{Ans}$$

$$\rightarrow \Sigma F_x = 0: \quad C_x = 0 \quad \text{Ans}$$

From (c),

$$\curvearrowleft + \Sigma M_B = 0: \quad 1.308(100) - 0.24525(825 - x) = 0$$

$$x = 292 \text{ mm} \quad \text{Ans}$$

$$+ \uparrow \Sigma F_y = 0: \quad 1.308 - 0.24525 - B_y = 0$$

$$B_y = 1.06 \text{ N} \quad \text{Ans}$$

$$\rightarrow \Sigma F_x = 0: \quad B_x = 0 \quad \text{Ans}$$

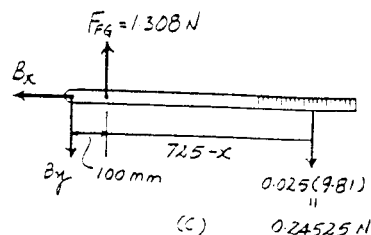
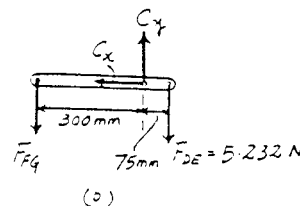
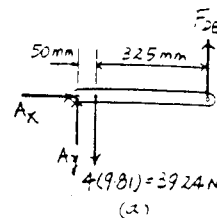

6-98. The scissors lift consists of two sets of cross members and two hydraulic cylinders, DE , symmetrically located on each side of the platform. The platform has a uniform mass of 60 kg, with a center of gravity at G_1 . The load of 85 kg, with center of gravity at G_2 , is centrally located on each side of the platform. Determine the force in each of the hydraulic cylinders for equilibrium. Rollers are located at B and D .

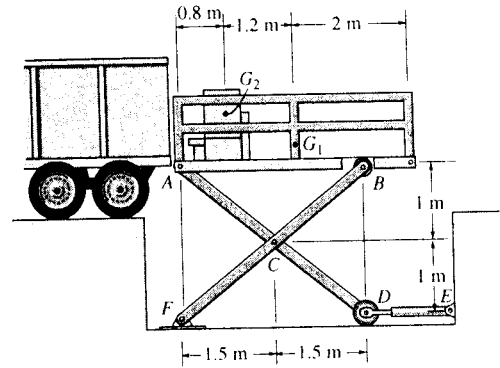

Free Body Diagram: The solution for this problem will be simplified if one realizes that the hydraulic cylinder DE is a two force member.

Equations of Equilibrium: From FBD (a),

$$\begin{aligned} \curvearrowright + \Sigma M_A = 0; & \quad 2N_B(3) - 833.85(0.8) - 588.6(2) = 0 \\ & \quad 2N_B = 614.76 \text{ N} \end{aligned}$$

$$\rightarrow \Sigma F_x = 0; \quad A_x = 0$$

$$\begin{aligned} + \uparrow \Sigma F_y = 0; & \quad 2A_y + 614.76 - 833.85 - 588.6 = 0 \\ & \quad 2A_y = 807.69 \text{ N} \end{aligned}$$

From FBD (b),

$$\begin{aligned} \curvearrowright + \Sigma M_D = 0; & \quad 807.69(3) - 2C_y(1.5) - 2C_x(1) = 0 \\ & \quad 2C_x + 3C_y = 2423.07 \end{aligned} \quad [1]$$

From FBD (c),

$$\begin{aligned} \curvearrowright + \Sigma M_F = 0; & \quad 2C_x(1) - 2C_y(1.5) - 614.76(3) = 0 \\ & \quad 2C_x - 3C_y = 1844.28 \end{aligned} \quad [2]$$

Solving Eqs. [1] and [2] yields

$$C_x = 1066.84 \text{ N} \quad C_y = 96.465 \text{ N}$$

From FBD (b),

$$\begin{aligned} \rightarrow \Sigma F_x = 0; & \quad 2(1066.84) - 2F_{DE} = 0 \\ & \quad F_{DE} = 1066.84 \text{ N} = 1.07 \text{ kN} \end{aligned} \quad \text{Ans}$$

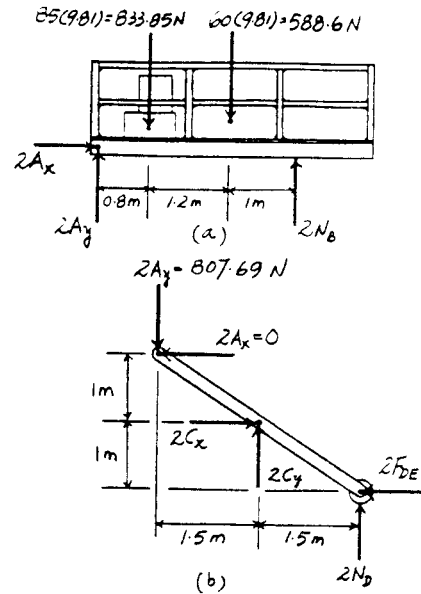

6-99. Determine the horizontal and vertical components of force that the pins at A , B , and C exert on the frame. The cylinder has a mass of 80 kg.

Equations of Equilibrium: From FBD (b).

$$\begin{aligned} \curvearrowleft + \Sigma M_B = 0; & \quad 784.8(1.7) - C_y(1) = 0 \\ & \quad C_y = 1334.16 \text{ N} = 1.33 \text{ kN} \quad \text{Ans} \end{aligned}$$

$$\begin{aligned} + \uparrow \Sigma F_y = 0; & \quad B_y + 784.8 - 1334.16 = 0 \\ & \quad B_y = 549 \text{ N} \quad \text{Ans} \end{aligned}$$

$$\rightarrow \Sigma F_x = 0; \quad C_x - B_x = 0 \quad [1]$$

From FBD (a),

$$\begin{aligned} \curvearrowleft + \Sigma M_A = 0; & \quad C_x(0.5) + 1334.16(1) - 784.8(1.7) - 784.8(1.9) = 0 \\ & \quad C_x = 2982.24 \text{ N} = 2.98 \text{ kN} \quad \text{Ans} \end{aligned}$$

$$\begin{aligned} + \uparrow \Sigma F_y = 0; & \quad A_y + 1334.16 - 784.8 - 784.8 = 0 \\ & \quad A_y = 235 \text{ N} \quad \text{Ans} \end{aligned}$$

$$\begin{aligned} \rightarrow \Sigma F_x = 0; & \quad A_x - 2982.24 = 0 \\ & \quad A_x = 2982.24 \text{ N} = 2.98 \text{ kN} \quad \text{Ans} \end{aligned}$$

Substitute $C_x = 2982.24 \text{ N}$ into Eq. [1] yields,

$$B_x = 2982.24 \text{ N} = 2.98 \text{ kN} \quad \text{Ans}$$

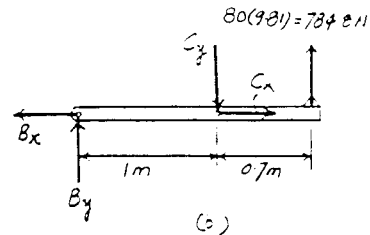
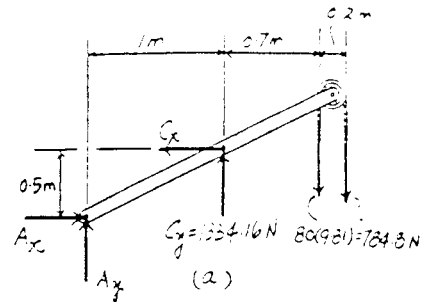
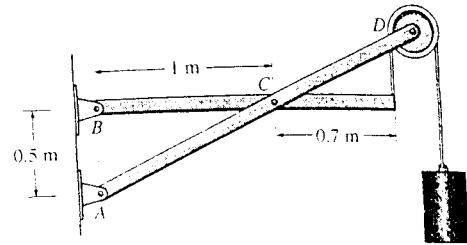

*6-100. By squeezing on the hand brake of the bicycle, the rider subjects the brake cable to a tension of 50 lb. If the caliper mechanism is pin-connected to the bicycle frame at B , determine the normal force each brake pad exerts on the rim of the wheel. Is this the force that stops the wheel from turning? Explain.

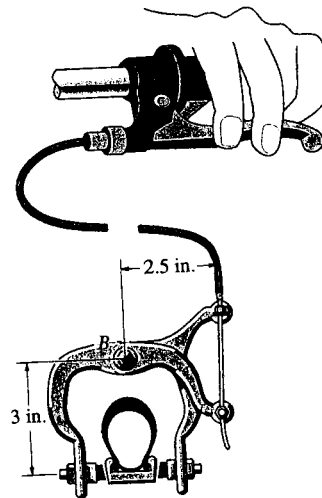

$$\curvearrowleft + \Sigma M_B = 0; \quad -N(3) + 50(2.5) = 0$$

$$N = 41.7 \text{ lb} \quad \text{Ans}$$

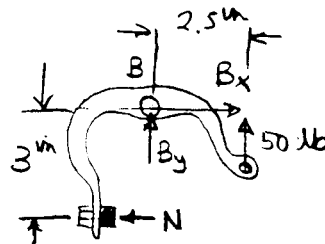

This normal force **does not** stop the wheel from turning. A frictional force (See Chapter 8), which acts along on the wheel's rim stops the wheel. **Ans**

6-101. If a force of $P = 6$ lb is applied perpendicular to the handle of the mechanism, determine the magnitude of force F for equilibrium. The members are pin-connected at A , B , C , and D .

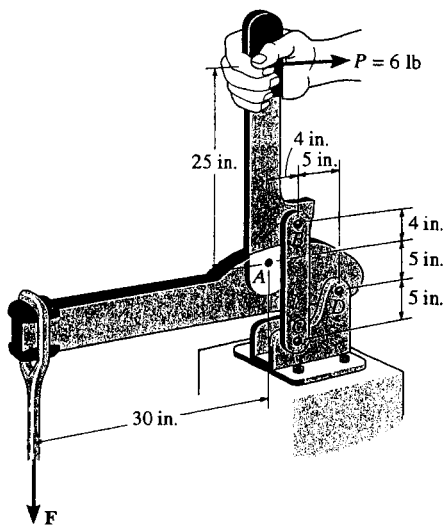

$$\curvearrowleft + \Sigma M_A = 0; \quad F_{BC}(4) - 6(25) = 0$$

$$F_{BC} = 37.5 \text{ lb}$$

$$\rightarrow \Sigma F_x = 0; \quad -A_x + 6 = 0$$

$$A_x = 6 \text{ lb}$$

$$+ \uparrow \Sigma F_y = 0; \quad -A_y + 37.5 = 0$$

$$A_y = 37.5 \text{ lb}$$

$$\curvearrowleft + \Sigma M_D = 0; \quad -5(6) - 37.5(9) + 39(F) = 0$$

$$F = 9.42 \text{ lb} \quad \text{Ans}$$

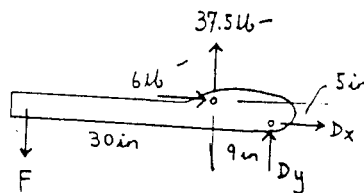
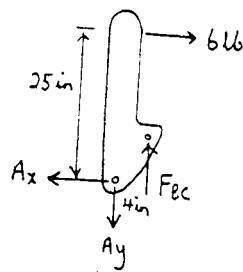

6-102. The bucket of the backhoe and its contents have a weight of 1200 lb and a center of gravity at G . Determine the forces of the hydraulic cylinder AB and in links AC and AD in order to hold the load in the position shown. The bucket is pinned at E .

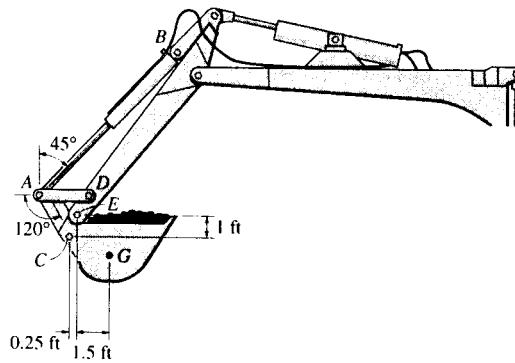

Free Body Diagram: The solution for this problem will be simplified if one realizes that the hydraulic cylinder AB , links AD and AC are two force members.

Equations of Equilibrium: From FBD (a),

$$\left(+ \Sigma M_E = 0; \quad F_{AC} \cos 60^\circ (1) + F_{AC} \sin 60^\circ (0.25) - 1200(1.5) = 0 \right.$$

$$F_{AC} = 2512.19 \text{ lb} = 2.51 \text{ kip} \quad \text{Ans}$$

Using method of joint [FBD (b)],

$$\begin{aligned} + \uparrow \Sigma F_y = 0; \quad & 2512.19 \sin 60^\circ - F_{AB} \cos 45^\circ = 0 \\ & F_{AB} = 3076.79 \text{ lb} = 3.08 \text{ kip} \quad \text{Ans} \end{aligned}$$

$$\begin{aligned} \rightarrow \Sigma F_x = 0; \quad & F_{AD} - 3076.79 \sin 45^\circ - 2512.19 \cos 60^\circ = 0 \\ & F_{AD} = 3431.72 \text{ lb} = 3.43 \text{ kip} \quad \text{Ans} \end{aligned}$$

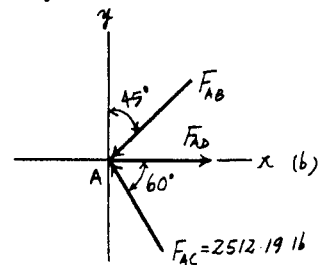
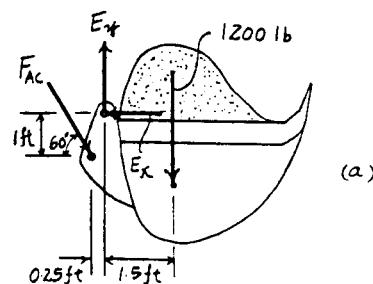

6-103. Two smooth tubes A and B , each having the same weight, W , are suspended from a common point O by means of equal-length cords. A third tube, C , is placed between A and B . Determine the greatest weight of C without upsetting equilibrium.

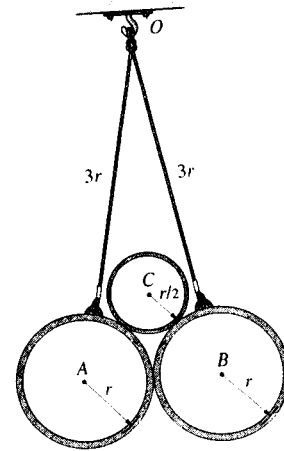

Free Body Diagram : When the equilibrium is about to be upset, the reaction at B must be zero ($N_B = 0$). From the geometry, $\phi = \cos^{-1}\left(\frac{r}{\frac{3}{2}r}\right) = 48.19^\circ$ and $\theta = \cos^{-1}\left(\frac{r}{4r}\right) = 75.52^\circ$.

Equations of Equilibrium : From FBD (a),

$$\rightarrow \Sigma F_x = 0; \quad T \cos 75.52^\circ - N_C \cos 48.19^\circ = 0 \quad [1]$$

$$+ \uparrow \Sigma F_y = 0; \quad T \sin 75.52^\circ - N_C \sin 48.19^\circ - W = 0 \quad [2]$$

Solving Eq. [1] and [2] yields,

$$T = 1.452W \quad N_C = 0.5445W$$

From FBD (b),

$$+ \uparrow \Sigma F_y = 0; \quad 2(0.5445W \sin 48.19^\circ) - W_C = 0$$

$$W_C = 0.812W \quad \text{Ans}$$

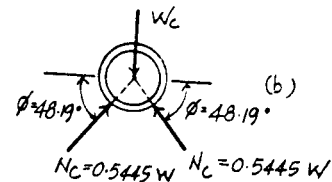
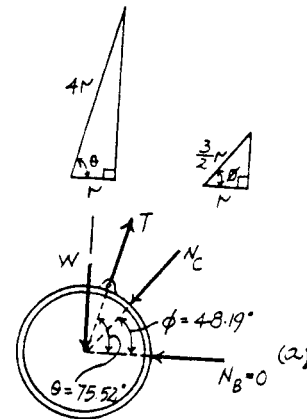

*6-104. The double link grip is used to lift the beam. If the beam weighs 4 kN, determine the horizontal and vertical components of force acting on the pin at A and the horizontal and vertical components of force that the flange of the beam exerts on the jaw at B .

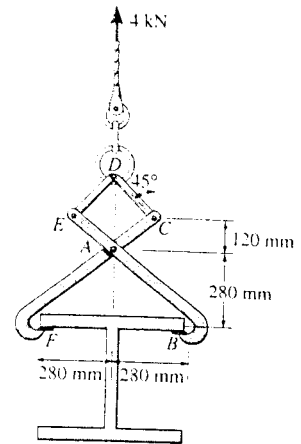

Free Body Diagram : The solution for this problem will be simplified if one realizes that members AD and CD are two force members.

Equations of Equilibrium : Using method of joint [FBD (a)].

$$+\uparrow \Sigma F_y = 0; \quad 4 - 2F \sin 45^\circ = 0 \quad F = 2.828 \text{ kN}$$

From FBD (b),

$$+\uparrow \Sigma F_y = 0; \quad 2B_y - 4 = 0 \quad B_y = 2.00 \text{ kN} \quad \text{Ans}$$

From FBD (c),

$$\begin{aligned} (+\Sigma M_A = 0; \quad B_x(280) - 2.00(280) - 2.828 \cos 45^\circ(120) \\ - 2.828 \sin 45^\circ(160) = 0 \\ B_x = 4.00 \text{ kN} \quad \text{Ans} \end{aligned}$$

$$+\uparrow \Sigma F_y = 0; \quad A_y + 2.828 \sin 45^\circ - 2.00 = 0 \\ A_y = 0 \quad \text{Ans}$$

$$\rightarrow \Sigma F_x = 0; \quad 4.00 + 2.828 \cos 45^\circ - A_x = 0 \\ A_x = 6.00 \text{ kN} \quad \text{Ans}$$

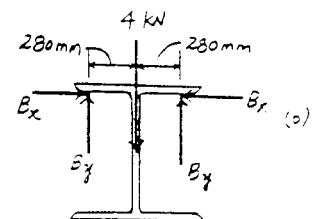
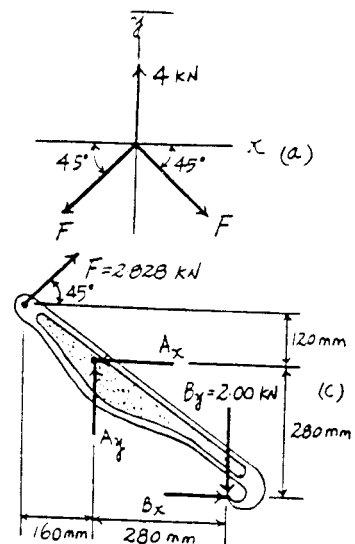

6-105. The compound beam is fixed supported at C and supported by rockers at A and B. If there are hinges (pins) at D and E, determine the components of reaction at the supports. Neglect the thickness of the beam.

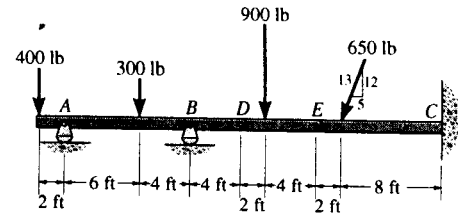

Equations of Equilibrium : From FBD (a),

$$\begin{aligned} \left(+\Sigma M_D = 0; \quad E_y(6) - 900(2) = 0 \quad E_y = 300 \text{ lb} \right. \\ \left. + \uparrow \Sigma F_y = 0; \quad D_y + 300 - 900 = 0 \quad D_y = 600 \text{ lb} \right. \\ \left. \rightarrow \Sigma F_x = 0; \quad D_x - E_x = 0 \right. \end{aligned} \quad [1]$$

From FBD (b),

$$\begin{aligned} \left(+\Sigma M_A = 0; \quad B_y(10) + 400(2) - 300(6) - 600(14) = 0 \right. \\ \left. B_y = 940 \text{ lb} \right. \quad \text{Ans} \\ \left. + \uparrow \Sigma F_y = 0; \quad A_y + 940 - 400 - 300 - 600 = 0 \right. \\ \left. A_y = 360 \text{ lb} \right. \quad \text{Ans} \\ \left. \rightarrow \Sigma F_x = 0; \quad D_x = 0 \right. \end{aligned}$$

Substitute $D_x = 0$ into Eq. [1] yields $E_x = 0$

From FBD (c),

$$\begin{aligned} \left(+\Sigma M_C = 0; \quad 300(10) + 650\left(\frac{12}{13}\right)(8) - M_C = 0 \right. \\ \left. M_C = 7800 \text{ lb} \cdot \text{ft} = 7.80 \text{ kip} \cdot \text{ft} \right. \quad \text{Ans} \\ \left. + \uparrow \Sigma F_y = 0; \quad C_y - 300 - 650\left(\frac{12}{13}\right) = 0 \quad C_y = 900 \text{ lb} \right. \quad \text{Ans} \\ \left. \rightarrow \Sigma F_x = 0; \quad C_x - 650\left(\frac{5}{13}\right) = 0 \quad C_x = 250 \text{ lb} \right. \quad \text{Ans} \end{aligned}$$

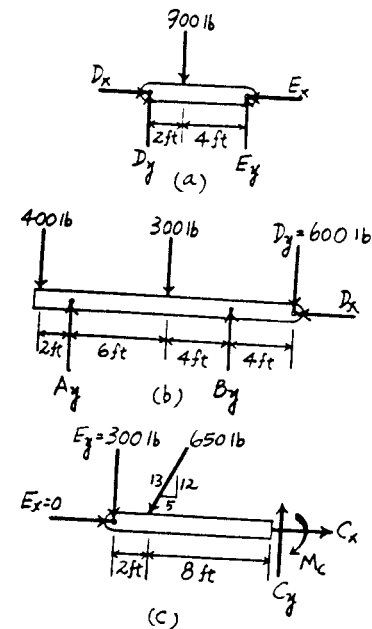

6-106. Determine the horizontal and vertical components of force at pin B and the normal force the pin at C exerts on the smooth slot. Also, determine the moment and horizontal and vertical reactions of force at A . There is a pulley at E .

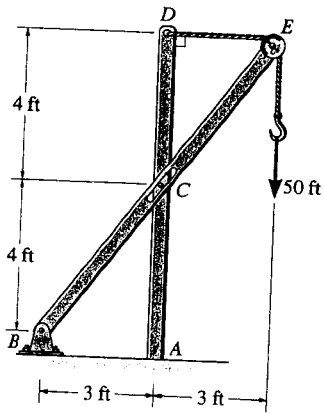

BCE :

$$\curvearrowleft + \Sigma M_B = 0; \quad -50(6) - N_C(5) + 50(8) = 0$$

$$N_C = 20 \text{ lb} \quad \text{Ans}$$

$$\rightarrow \Sigma F_x = 0; \quad B_x + 20\left(\frac{4}{5}\right) - 50 = 0$$

$$B_x = 34 \text{ lb} \quad \text{Ans}$$

$$+\uparrow \Sigma F_y = 0; \quad B_y - 20\left(\frac{3}{5}\right) - 50 = 0$$

$$B_y = 62 \text{ lb} \quad \text{Ans}$$

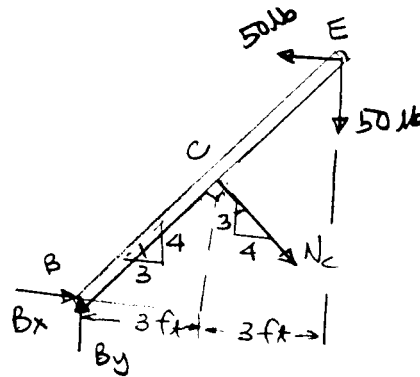

ACD :

$$\rightarrow \Sigma F_x = 0; \quad -A_x - 20\left(\frac{4}{5}\right) + 50 = 0$$

$$A_x = 34 \text{ lb} \quad \text{Ans}$$

$$+\uparrow \Sigma F_y = 0; \quad -A_y + 20\left(\frac{3}{5}\right) = 0$$

$$A_y = 12 \text{ lb} \quad \text{Ans}$$

$$\curvearrowleft + \Sigma M_A = 0; \quad M_A + 20\left(\frac{4}{5}\right)(4) - 50(8) = 0$$

$$M_A = 336 \text{ lb}\cdot\text{ft} \quad \text{Ans}$$

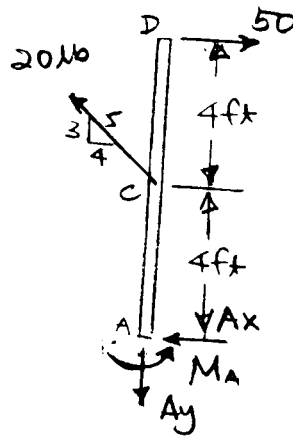

6-107. The symmetric coil tong supports the coil which has a mass of 800 kg and center of mass at G . Determine the horizontal and vertical components of force the linkage exerts on plate $DEIJH$ at points D and E . The coil exerts only vertical reactions at K and L .

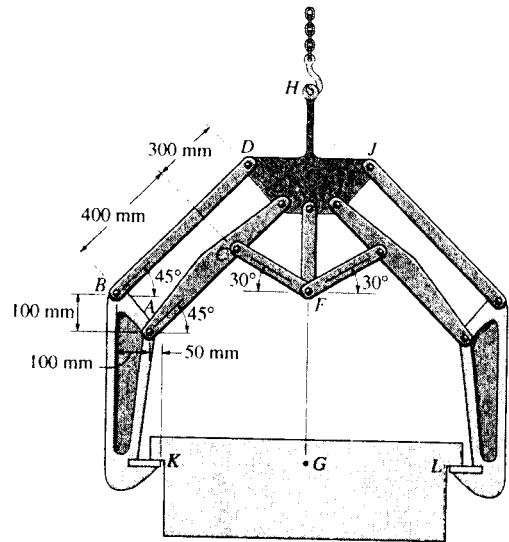

Free Body Diagram : The solution for this problem will be simplified if one realizes that links BD and CF are the two force members.

Equations of Equilibrium : From FBD (a).

$$\left(+ \Sigma M_L = 0; \quad 7848(x) - F_K(2x) = 0 \quad F_K = 3924 \text{ N} \right.$$

From FBD (b),

$$\left(+ \Sigma M_A = 0; \quad F_{BD} \cos 45^\circ (100) + F_{BD} \sin 45^\circ (100) - 3924(50) = 0 \right. \\ \left. F_{BD} = 1387.34 \text{ N} \right.$$

$$\rightarrow \Sigma F_x = 0; \quad A_x - 1387.34 \cos 45^\circ = 0 \quad A_x = 981 \text{ N}$$

$$+ \uparrow \Sigma F_y = 0; \quad A_y - 3924 - 1387.34 \sin 45^\circ = 0 \\ A_y = 4905 \text{ N}$$

From FBD (c),

$$\left(+ \Sigma M_E = 0; \quad 4905 \sin 45^\circ (700) - 981 \sin 45^\circ (700) \right. \\ \left. - F_{CF} \cos 15^\circ (300) = 0 \right. \\ \left. F_{CF} = 6702.66 \text{ N} \right.$$

$$\rightarrow \Sigma F_x = 0; \quad E_x - 981 - 6702.66 \cos 30^\circ = 0 \\ E_x = 6785.67 \text{ N} = 6.79 \text{ kN} \quad \text{Ans}$$

$$+ \uparrow \Sigma F_y = 0; \quad E_y + 6702.66 \sin 30^\circ - 4905 = 0 \\ E_y = 1553.67 \text{ N} = 1.55 \text{ kN} \quad \text{Ans}$$

At point D ,

$$D_x = F_{BD} \cos 45^\circ = 1387.34 \cos 45^\circ = 981 \text{ N} \quad \text{Ans}$$

$$D_y = F_{BD} \sin 45^\circ = 1387.34 \sin 45^\circ = 981 \text{ N} \quad \text{Ans}$$

$$800(9.81) = 7848 \text{ N}$$

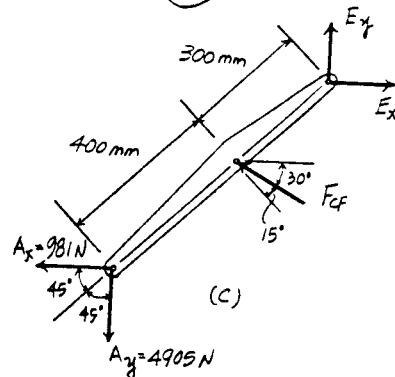
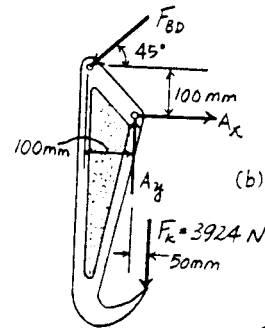
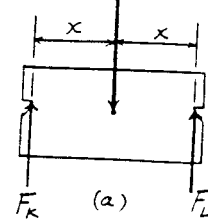

*6-108. If a force of 10 lb is applied to the grip of the clamp, determine the compressive force F that the wood block exerts on the clamp.

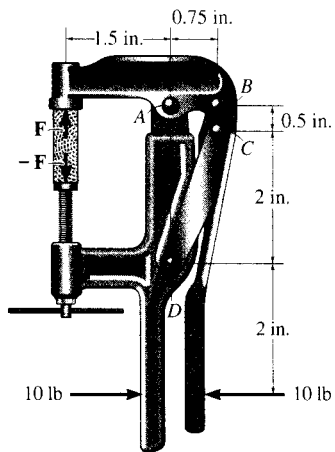

From FBD (a)

$$\sum M_B = 0; \quad F_{CD} \cos 69.44^\circ (0.5) - 10(4.5) = 0 \quad F_{CD} = 256.32 \text{ lb}$$

$$+\uparrow \sum F_y = 0; \quad 256.32 \sin 69.44^\circ - B_y = 0 \quad B_y = 240 \text{ lb}$$

From FBD (b)

$$\sum M_A = 0; \quad 240(0.75) - F(1.5) = 0 \quad F = 120 \text{ lb} \quad \text{Ans}$$

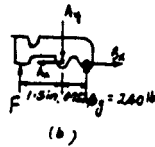
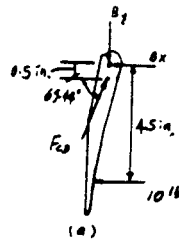

6-109. If each of the three uniform links of the mechanism has a length L and weight W , determine the angle θ for equilibrium. The spring, which always remains vertical, is unstretched when $\theta = 0^\circ$.

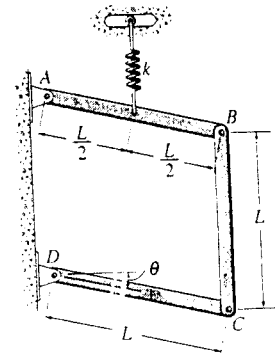

Free Body Diagram : The spring stretches $x = \frac{L}{2} \sin \theta$. Then, the spring force is $F_{sp} = kx = \frac{kL}{2} \sin \theta$.

Equations of Equilibrium : From FBD (b),

$$\left(+ \Sigma M_B = 0; \quad C_x = 0 \right.$$

$$\left. \begin{aligned} \rightarrow \Sigma F_x = 0; \quad B_x = 0 \\ + \uparrow \Sigma F_y = 0; \quad B_y - C_y - W = 0 \end{aligned} \right. \quad [1]$$

From FBD (a),

$$\left(+ \Sigma M_D = 0; \quad C_y (L \cos \theta) - W \left(\frac{L}{2} \cos \theta \right) = 0 \right.$$

$$\left. \quad \quad \quad C_y = \frac{W}{2} \right.$$

Substitute $C_y = \frac{W}{2}$ into Eq. [1], we have $B_y = \frac{3W}{2}$. From FBD (c),

$$\left(+ \Sigma M_A = 0; \quad \frac{kL}{2} \sin \theta \left(\frac{L}{2} \cos \theta \right) \right.$$

$$\left. - W \left(\frac{L}{2} \cos \theta \right) - \frac{3W}{2} (L \cos \theta) = 0 \right.$$

$$\theta = \sin^{-1} \left(\frac{8W}{kL} \right) \quad \text{Ans}$$

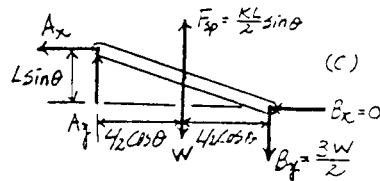
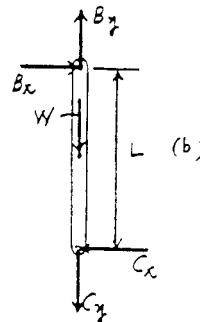
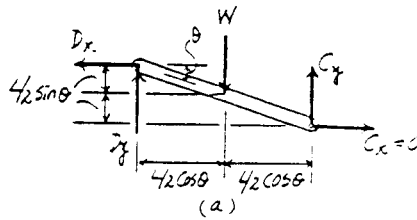

6-110. The flat-bed trailer has a weight of 7000 lb and center of gravity at G_T . It is pin-connected to the cab at D . The cab has a weight of 6000 lb and center of gravity at G_C . Determine the range of values x for the position of the 2000-lb load L so that when it is placed over the rear axle, no axle is subjected to more than 5500 lb. The load has a center of gravity at G_L .

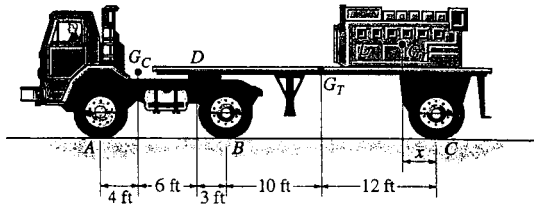

Case 1 : Assume $A_y = 5500$ lb

$$\zeta + \Sigma M_B = 0; \quad -5500(13) + 6000(9) + D_y(3) = 0$$

$$D_y = 5833.33 \text{ lb}$$

$$+ \uparrow \Sigma F_y = 0; \quad B_y - 6000 - 5833.33 + 5500 = 0$$

$$B_y = 6333.33 \text{ lb} > 5500 \text{ lb} \quad (\text{N.G.})$$

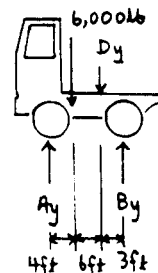

Case 2 : Assume $B_y = 5500$ lb

$$\zeta + \Sigma M_A = 0; \quad 5500(13) - 6000(4) - D_y(10) = 0$$

$$D_y = 4750 \text{ lb}$$

$$+ \uparrow \Sigma F_y = 0; \quad A_y - 6000 - 4750 + 5500 = 0$$

$$A_y = 5250 \text{ lb}$$

$$+ \uparrow \Sigma F_y = 0; \quad 4750 - 7000 - 2000 + C_y = 0$$

$$C_y = 4250 \text{ lb} < 5500 \text{ lb} \quad (\text{O.K.})$$

$$\zeta + \Sigma M_D = 0; \quad -7000(13) - 2000(13 + 12 - x) + 4250(25) = 0$$

$$x = 17.4 \text{ ft}$$

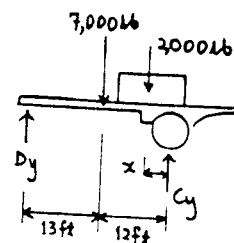

6-110 cont'd

Case 3 : Assume $C_y = 5500$ lb

$$+\uparrow \Sigma F_y = 0; \quad D_y - 9000 + 5500 = 0$$

$$D_y = 3500 \text{ lb}$$

$$\curvearrowright + \Sigma M_C = 0; \quad -3500(25) + 7000(12) + 2000(x) = 0$$

$$x = 1.75 \text{ ft}$$

$$\curvearrowright + \Sigma M_A = 0; \quad -6000(4) - 3500(10) + B_y(13) = 0$$

$$B_y = 4538.46 \text{ lb} < 5500 \text{ lb} \quad (\text{O.K.})$$

$$+\uparrow \Sigma F_y = 0; \quad A_y - 6000 - 3500 + 4538.46 = 0$$

$$A_y = 4961.54 \text{ lb} < 5500 \text{ lb} \quad (\text{O.K.})$$

Thus, $1.75 \text{ ft} \leq x \leq 17.4 \text{ ft} \quad \text{Ans}$

6-111. The three pin-connected members shown in the top view support a downward force of 60 lb at G. If only vertical forces are supported at the connections B, C, E and pad supports A, D, F, determine the reactions at each pad.

Equations of Equilibrium : From FBD (a),

$$\curvearrowright + \Sigma M_D = 0; \quad 60(8) + F_C(6) - F_B(10) = 0 \quad [1]$$

$$+\uparrow \Sigma F_y = 0; \quad F_B + F_D - F_C - 60 = 0 \quad [2]$$

From FBD (b),

$$\curvearrowright + \Sigma M_F = 0; \quad F_E(6) - F_C(10) = 0 \quad [3]$$

$$+\uparrow \Sigma F_y = 0; \quad F_C + F_F - F_E = 0 \quad [4]$$

From FBD (c),

$$\curvearrowright + \Sigma M_A = 0; \quad F_E(10) - F_B(6) = 0 \quad [5]$$

$$+\uparrow \Sigma F_y = 0; \quad F_A + F_E - F_B = 0 \quad [6]$$

Solving Eqs. [1], [2], [3], [4], [5] and [6] yields,

$$\begin{aligned} F_E &= 36.73 \text{ lb} & F_C &= 22.04 \text{ lb} & F_B &= 61.22 \text{ lb} \\ F_D &= 20.8 \text{ lb} & F_F &= 14.7 \text{ lb} & F_A &= 24.5 \text{ lb} \end{aligned} \quad \text{Ans}$$

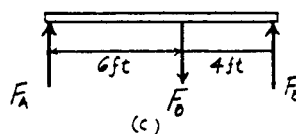
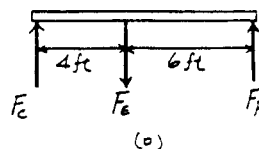
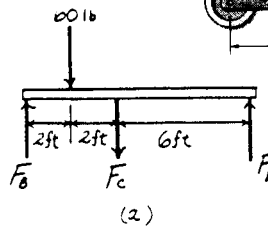
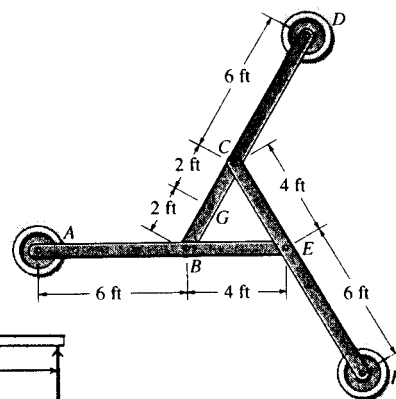

*6-112. The aircraft-hangar door opens and closes slowly by means of a motor which draws in the cable AB . If the door is made in two sections (bifold) and each section has a uniform weight W and length L , determine the force in the cable as a function of the door's position θ . The sections are pin-connected at C and D and the bottom is attached to a roller that travels along the vertical track.

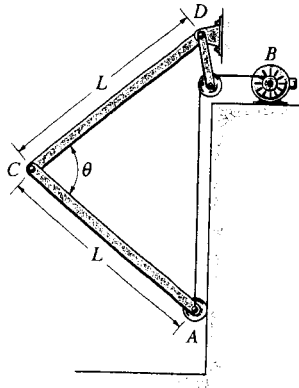

$$\sum M_D = 0: \quad 2(W)\left(\frac{L}{2}\right)\cos\left(\frac{\theta}{2}\right) - 2L\left(\sin\left(\frac{\theta}{2}\right)\right)N_A = 0$$

$$N_A = \frac{W}{2\tan\left(\frac{\theta}{2}\right)}$$

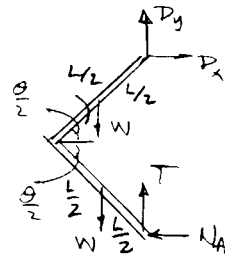

$$\sum M_C = 0: \quad TL\left(\cos\left(\frac{\theta}{2}\right)\right) - \frac{W}{2\tan\left(\frac{\theta}{2}\right)}\left(L\sin\left(\frac{\theta}{2}\right)\right) - W\left(\frac{L}{2}\right)\left(\cos\left(\frac{\theta}{2}\right)\right) = 0$$

$$T = W \quad \text{Ans}$$

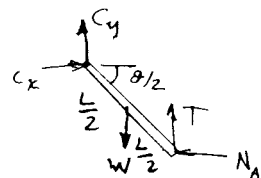

6-113. A man having a weight of 175 lb attempts to lift himself using one of the two methods shown. Determine the total force he must exert on bar AB in each case and the normal reaction he exerts on the platform at C . Neglect the weight of the platform.

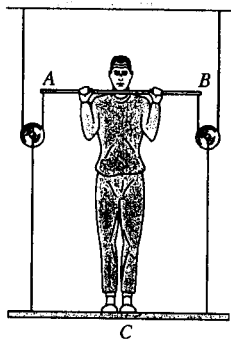

(a)

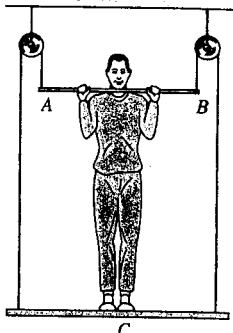

(b)

(a)

Bar :

$$+\uparrow \Sigma F_y = 0; \quad 2(F/2) - 2(87.5) = 0$$

$$F = 175 \text{ lb} \quad \text{Ans}$$

Man :

$$+\uparrow \Sigma F_y = 0; \quad N_C - 175 - 2(87.5) = 0$$

$$N_C = 350 \text{ lb} \quad \text{Ans}$$

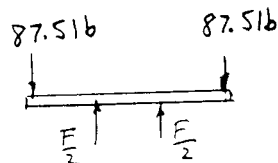

(b)

Bar :

$$+\uparrow \Sigma F_y = 0; \quad 2(43.75) - 2(F/2) = 0$$

$$F = 87.5 \text{ lb} \quad \text{Ans}$$

Man :

$$+\uparrow \Sigma F_y = 0; \quad N_C - 175 + 2(43.75) = 0$$

$$N_C = 87.5 \text{ lb} \quad \text{Ans}$$

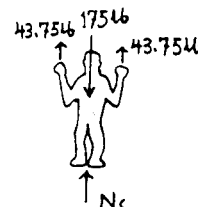
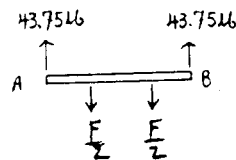

6-114. A man having a weight of 175 lb attempts to lift himself using one of the two methods shown. Determine the total force he must exert on bar AB in each case and the normal reaction he exerts on the platform at C . The platform has a weight of 30 lb.

(a)

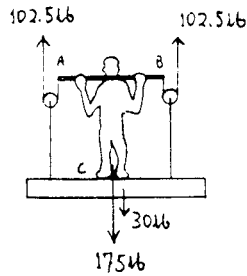

Bar :

$$+\uparrow \Sigma F_y = 0; \quad 2(F/2) - 102.5 - 102.5 = 0$$

$$F = 205 \text{ lb} \quad \text{Ans}$$

Man :

$$+\uparrow \Sigma F_y = 0; \quad N_C - 175 - 102.5 - 102.5 = 0$$

$$N_C = 380 \text{ lb} \quad \text{Ans}$$

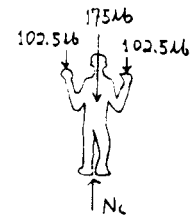
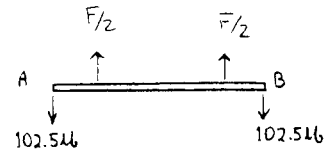

(b)

Bar :

$$+\uparrow \Sigma F_y = 0; \quad 2(F/2) - 51.25 - 51.25 = 0$$

$$F = 102 \text{ lb} \quad \text{Ans}$$

Man :

$$+\uparrow \Sigma F_y = 0; \quad N_C - 175 + 51.25 + 51.25 = 0$$

$$N_C = 72.5 \text{ lb} \quad \text{Ans}$$

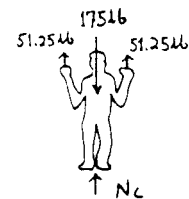
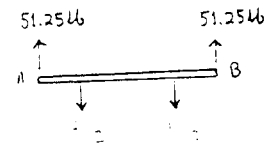
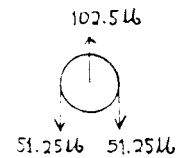

6-115. The piston C moves vertically between the two smooth walls. If the spring has a stiffness of $k = 15 \text{ lb/in.}$, and is unstretched when $\theta = 0^\circ$, determine the couple M that must be applied to AB to hold the mechanism in equilibrium when $\theta = 30^\circ$.

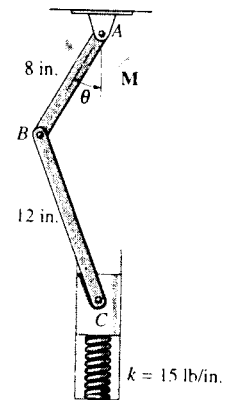

Geometry :

$$\frac{\sin \psi}{8} = \frac{\sin 30^\circ}{12} \quad \psi = 19.47^\circ$$

$$\phi = 180^\circ - 30^\circ - 19.47^\circ = 130.53^\circ$$

$$\frac{l_{AC}}{\sin 130.53^\circ} = \frac{12}{\sin 30^\circ} \quad l_{AC} = 18.242 \text{ in.}$$

Free Body Diagram : The solution for this problem will be simplified if one realizes that member CB is a two force member. Since the spring stretches $x = l_{AC} - l_{AC} = 20 - 18.242 = 1.758 \text{ in.}$ the spring force is $F_p = kx = 15(1.758) = 26.37 \text{ lb.}$

Equations of Equilibrium : Using the method of joints [FBD (a)],

$$+\uparrow \Sigma F_y = 0; \quad F_{CB} \cos 19.47^\circ - 26.37 = 0$$

$$F_{CB} = 27.97 \text{ lb}$$

From FBD (b),

$$+\Sigma M_A = 0; \quad 27.97 \cos 40.53^\circ (8) - M = 0$$

$$M = 170.08 \text{ lb} \cdot \text{in} = 14.2 \text{ lb} \cdot \text{ft} \quad \text{Ans}$$

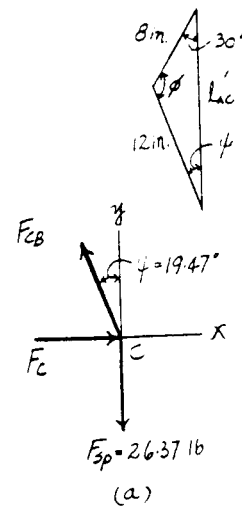

*6-116. The two-member frame supports the loading shown. Determine the force of the roller at B on member AC and the horizontal and vertical components of force which the pin at C exerts on member CB and the pin at A exerts on member AC . The roller does not contact member CB .

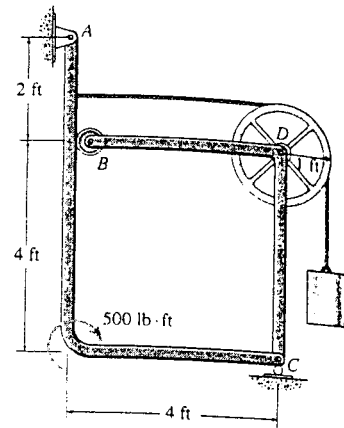

Equations of Equilibrium : From FBD (a),

$$\begin{aligned} (+\Sigma M_A = 0; \quad N_C(4) - 200(5) - 500 = 0 \quad N_C = 375 \text{ lb} \\ \rightarrow F_x = 0; \quad A_x = 0 \quad \text{Ans} \\ +\uparrow \Sigma F_y = 0; \quad 375 - 200 - A_y = 0 \quad A_y = 175 \text{ lb} \quad \text{Ans} \end{aligned}$$

From: FBD (b),

$$\begin{aligned} (+\Sigma M_C = 0; \quad 200(5) - 200(1) - B_x(4) = 0 \\ B_x = 200 \text{ lb} \quad \text{Ans} \\ \rightarrow F_x = 0; \quad 200 - 200 - C_x = 0 \quad C_x = 0 \quad \text{Ans} \\ +\uparrow \Sigma F_y = 0; \quad C_y - 200 = 0 \quad C_y = 200 \text{ lb} \quad \text{Ans} \end{aligned}$$

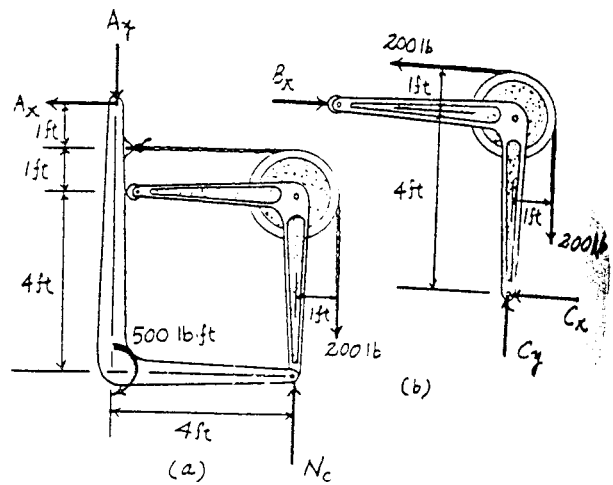

6-117. The tractor boom supports the uniform mass of 500 kg in the bucket which has a center of mass at G . Determine the force in each hydraulic cylinder AB and CD and the resultant force at pins E and F . The load is supported equally on each side of the tractor by a similar mechanism.

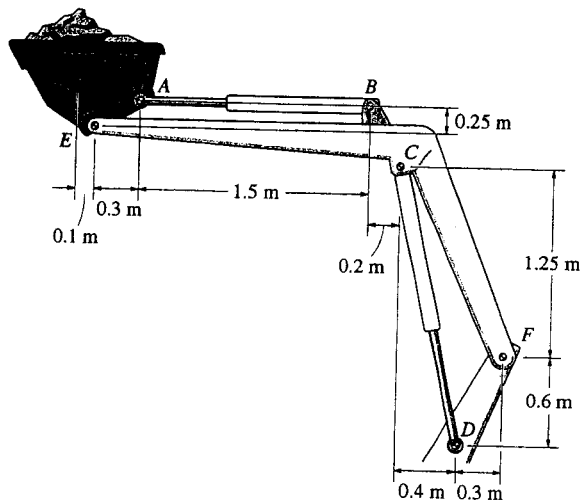

$$\curvearrow + \Sigma M_E = 0; \quad 2452.5(0.1) - F_{AB}(0.25) = 0$$

$$F_{AB} = 981 \text{ N} \quad \text{Ans}$$

$$\rightarrow \Sigma F_x = 0; \quad -E_x + 981 = 0; \quad E_x = 981 \text{ N}$$

$$+\uparrow \Sigma F_y = 0; \quad E_y - 2452.5 = 0; \quad E_y = 2452.5 \text{ N}$$

$$F_E = \sqrt{(981)^2 + (2452.5)^2} = 2.64 \text{ kN} \quad \text{Ans}$$

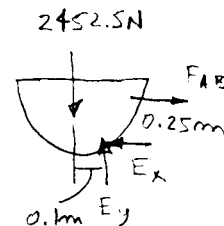

$$\curvearrow + \Sigma M_F = 0; \quad 2452.5(2.80) - F_{CD}(\cos 12.2^\circ)(0.7) + F_{CD}(\sin 12.2^\circ)(1.25) = 0$$

$$F_{CD} = 16\,349 \text{ N} = 16.3 \text{ kN} \quad \text{Ans}$$

$$\rightarrow \Sigma F_x = 0; \quad F_x - 16\,349 \sin 12.2^\circ = 0$$

$$F_x = 3455 \text{ N}$$

$$+\uparrow \Sigma F_y = 0; \quad -F_y - 2452.5 + 16\,349 \cos 12.2^\circ = 0$$

$$F_y = 13\,527 \text{ N}$$

$$F_F = \sqrt{(3455)^2 + (13\,527)^2} = 14.0 \text{ kN} \quad \text{Ans}$$

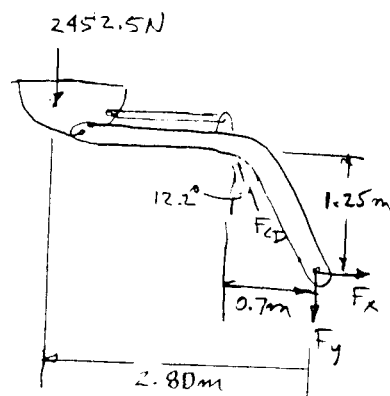

6-118. The mechanism is used to hide kitchen appliances under a cabinet by allowing the shelf to rotate downward. If the mixer weighs 10 lb, is centered on the shelf, and has a mass center at G , determine the stretch in the spring necessary to hold the shelf in the equilibrium position shown. There is a similar mechanism on each side of the shelf, so that each mechanism supports 5 lb of the load. The springs each have a stiffness of $k = 4$ lb/in. spring.

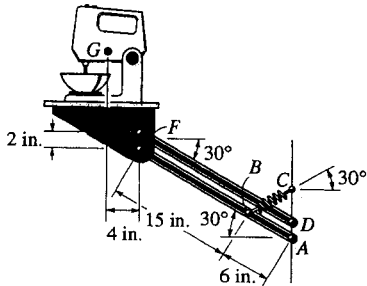

$$\curvearrowleft + \Sigma M_F = 0; \quad 5(4) - 2(F_{ED})(\cos 30^\circ) = 0$$

$$F_{ED} = 11.547 \text{ lb}$$

$$\rightarrow \Sigma F_x = 0; \quad -F_x + 11.547 \cos 30^\circ = 0$$

$$F_x = 10.00 \text{ lb}$$

$$+ \uparrow \Sigma F_y = 0; \quad -5 + F_y - 11.547 \sin 30^\circ = 0$$

$$F_y = 10.77 \text{ lb}$$

Member FBA :

$$\curvearrowleft + \Sigma M_A = 0; \quad 10.77(21 \cos 30^\circ) - 10(21 \sin 30^\circ) - F_s(\sin 60^\circ)(6) = 0$$

$$F_s = 17.5 \text{ lb}$$

$$F_s = ks; \quad 17.5 = 4x$$

$$x = 4.38 \text{ in.} \quad \text{Ans}$$

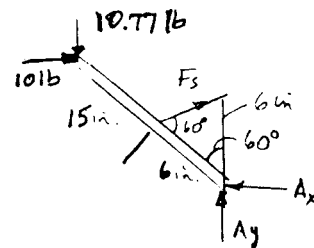
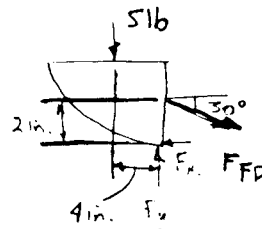

6-119. The linkage for a hydraulic jack is shown. If the load on the jack is 2000 lb, determine the pressure acting on the fluid when the jack is in the position shown. All lettered points are pins. The piston at H has a cross-sectional area of $A = 2 \text{ in}^2$. *Hint:* First find the force F acting along link EH . The pressure in the fluid is $p = F/A$.

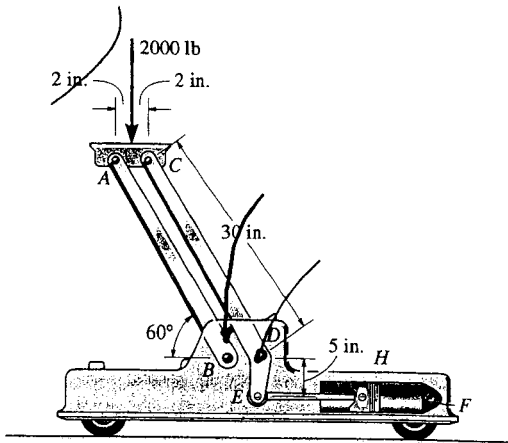

$$\curvearrowleft + \Sigma M_C = 0; \quad -F_{AB}(\sin 60^\circ)(4) + 2000(2) = 0$$

$$F_{AB} = 1154.70 \text{ lb}$$

$$\rightarrow \Sigma F_x = 0; \quad C_x - F_{AB} \cos 60^\circ = 0$$

$$C_x = 577.35 \text{ lb}$$

$$+\uparrow \Sigma F_y = 0; \quad C_y + 1154.70 \sin 60^\circ - 2000 = 0$$

$$C_y = 1000 \text{ lb}$$

$$\curvearrowleft + \Sigma M_D = 0; \quad -F(5) + 1000(30 \cos 60^\circ) + 577.35(30 \sin 60^\circ) = 0$$

$$F = 6000 \text{ lb}$$

$$p = \frac{F}{A} = \frac{6000}{2} = 3000 \text{ psi} \quad \text{Ans}$$

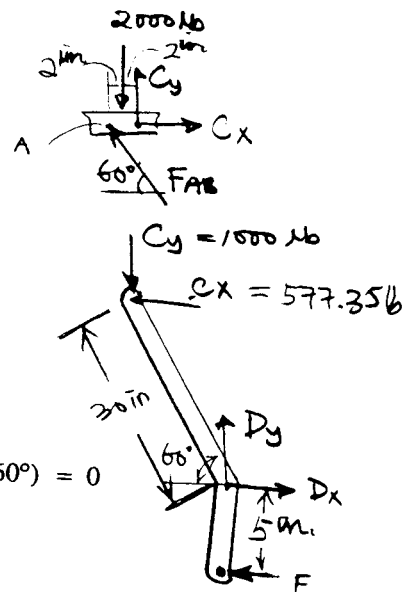

*6-120. Determine the required force P that must be applied at the blade of the pruning shears so that the blade exerts a normal force of 20 lb on the twig at E .

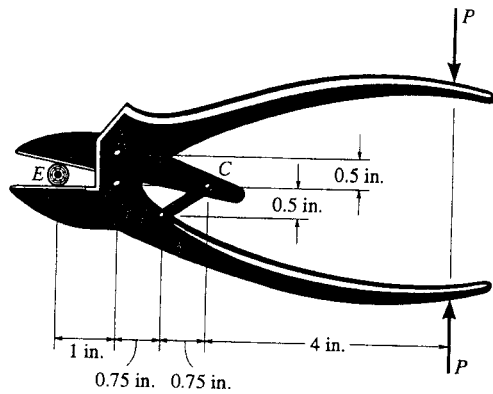

$$\curvearrowleft + \Sigma M_D = 0; \quad -P(5.5) - A_x(0.5) + 20(1) = 0$$

$$5.5P + 0.5A_x = 20$$

$$+\uparrow \Sigma F_y = 0; \quad D_y - P - A_y - 20 = 0$$

$$\rightarrow \Sigma F_x = 0; \quad D_x = A_x$$

$$\curvearrowleft + \Sigma M_B = 0; \quad A_y(0.75) + A_x(0.5) - 4.75P = 0$$

$$\rightarrow \Sigma F_x = 0; \quad A_x - F_{CB} \left(\frac{3}{\sqrt{13}} \right) = 0$$

$$+\uparrow \Sigma F_y = 0; \quad A_y + P - F_{CB} \left(\frac{2}{\sqrt{13}} \right) = 0$$

Solving:

$$A_x = 13.3 \text{ lb}$$

$$A_y = 6.46 \text{ lb}$$

$$D_x = 13.3 \text{ lb}$$

$$D_y = 28.9 \text{ lb}$$

$$P = 2.42 \text{ lb}$$

Ans

$$F_{CB} = 16.0 \text{ lb}$$

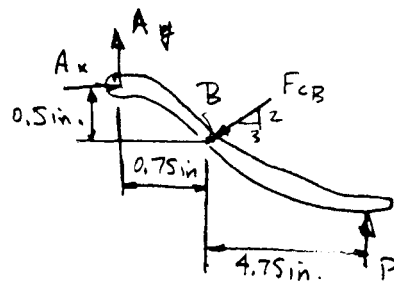
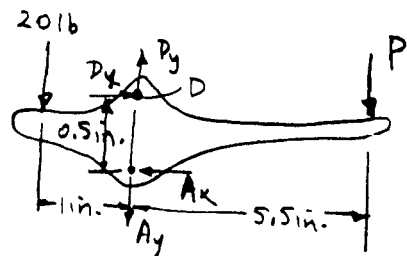

6-121. The three power lines exert the forces shown on the truss joints, which in turn are pin-connected to the poles AH and EG. Determine the force in the guy cable AI and the pin reaction at the support H.

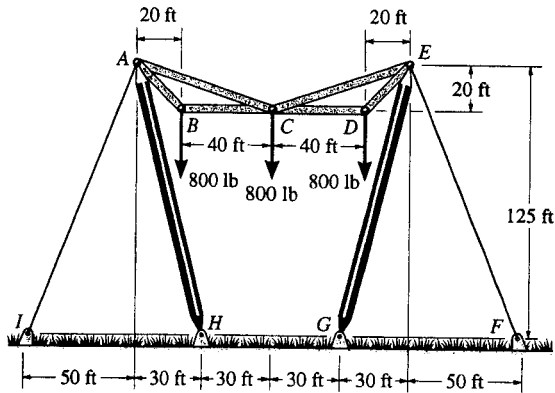

AH is a two-force member.

Joint B :

$$+\uparrow \Sigma F_y = 0; \quad F_{AB} \sin 45^\circ - 800 = 0$$

$$F_{AB} = 1131.37 \text{ lb}$$

Joint C :

$$+\uparrow \Sigma F_y = 0; \quad 2F_{CA} \sin 18.435^\circ - 800 = 0$$

$$F_{CA} = 1264.91 \text{ lb}$$

Joint A :

$$\rightarrow \Sigma F_x = 0; \quad -T_{AI} \sin 21.801^\circ - F_H \cos 76.504^\circ + 1264.91 \cos 18.435^\circ + 1131.37 \cos 45^\circ = 0$$

$$+\uparrow \Sigma F_y = 0; \quad -T_{AI} \cos 21.801^\circ + F_H \sin 76.504^\circ - 1131.37 \sin 45^\circ - 1264.91 \sin 18.435^\circ = 0$$

$$T_{AI}(0.3714) + F_H(0.2334) = 2000$$

$$-T_{AI}(0.9285) + F_H(0.97239) = 1200$$

Solving,

$$T_{AI} = T_{EF} = 2.88 \text{ kip} \quad \text{Ans}$$

$$F_H = F_G = 3.99 \text{ kip} \quad \text{Ans}$$

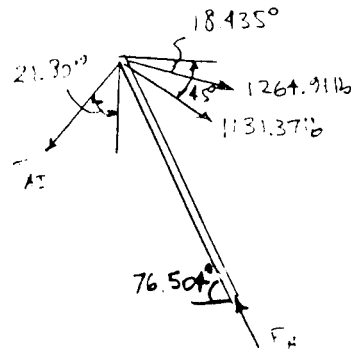
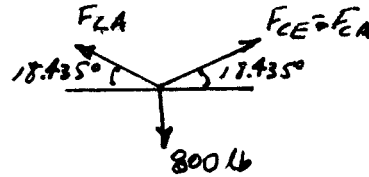
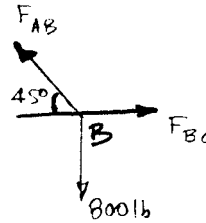

6-122. The hydraulic crane is used to lift the 1400-lb load. Determine the force in the hydraulic cylinder AB and the force in links AC and AD when the load is held in the position shown.

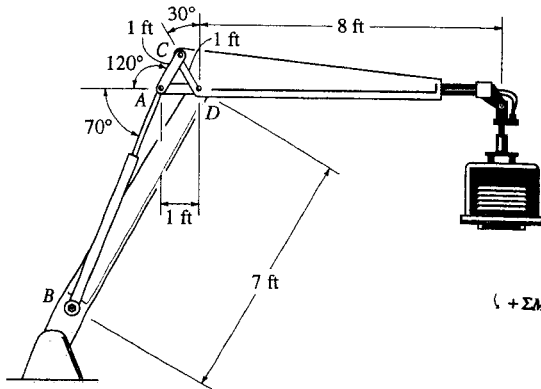

$$\zeta + \Sigma M_D = 0; \quad F_{CA}(\sin 60^\circ)(1) - 1400(8) = 0$$

$$F_{CA} = 12\,932.65 \text{ lb} = 12.9 \text{ kip} \quad \text{Ans}$$

$$+\uparrow \Sigma F_y = 0; \quad 12\,932.65 \sin 60^\circ - F_{AB} \sin 70^\circ = 0$$

$$F_{AB} = 11\,918.79 \text{ lb} = 11.9 \text{ kip} \quad \text{Ans}$$

$$\rightarrow \Sigma F_x = 0; \quad -11\,918.79 \cos 70^\circ + 12\,932.65 \cos 60^\circ - F_{AD} = 0$$

$$F_{AD} = 2389.85 \text{ lb} = 2.39 \text{ kip} \quad \text{Ans}$$

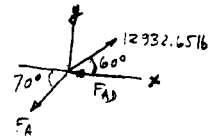
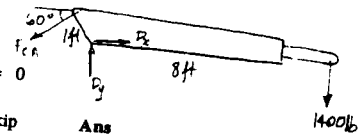

6-123. The kinetic sculpture requires that each of the three pinned beams be in perfect balance at all times during its slow motion. If each member has a uniform weight of 2 lb/ft and length of 3 ft, determine the necessary counterweights W_1 , W_2 , and W_3 which must be added to the ends of each member to keep the system in balance for any position. Neglect the size of the counterweights.

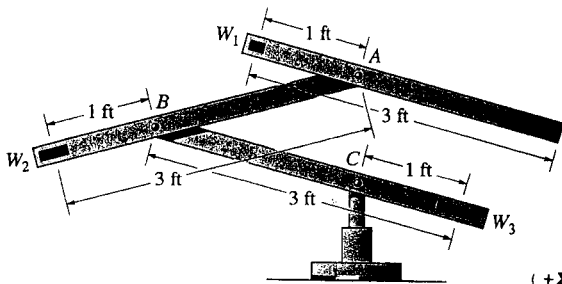

$$\zeta + \Sigma M_A = 0; \quad W_1(1 \cos \theta) - 6(0.5 \cos \theta) = 0$$

$$W_1 = 3 \text{ lb} \quad \text{Ans}$$

$$+\uparrow \Sigma F_y = 0; \quad R_A - 3 - 6 = 0$$

$$R_A = 9 \text{ lb}$$

$$\zeta + \Sigma M_B = 0; \quad W_2(1 \cos \phi) - 6(0.5 \cos \phi) - 9(2 \cos \phi) = 0$$

$$W_2 = 21 \text{ lb} \quad \text{Ans}$$

$$+\uparrow \Sigma F_y = 0; \quad R_B - 21 - 6 - 9 = 0$$

$$R_B = 36 \text{ lb}$$

$$\zeta + \Sigma M_C = 0; \quad 36(2 \cos \phi) + 6(0.5 \cos \phi) - W_3(1 \cos \phi) = 0$$

$$W_3 = 75 \text{ lb} \quad \text{Ans}$$

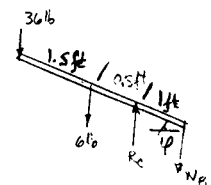
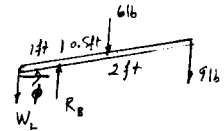
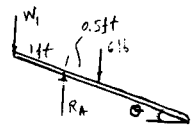

*6-124. The three-member frame is connected at its ends using ball-and-socket joints. Determine the x , y , z components of reaction at B and the tension in member ED . The force acting at D is $\mathbf{F} = \{135\mathbf{i} + 200\mathbf{j} - 180\mathbf{k}\}$ lb.

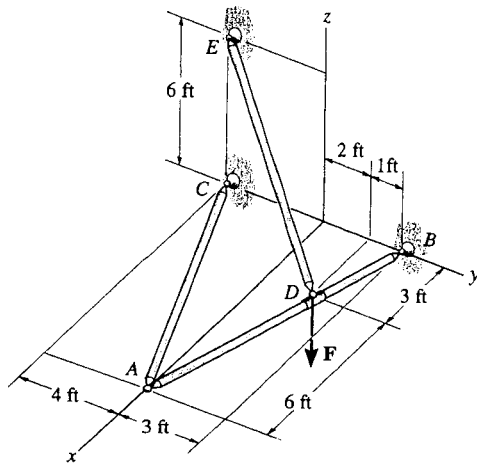

AC is a two-force member.

$$\mathbf{F} = \{135\mathbf{i} + 200\mathbf{j} - 180\mathbf{k}\} \text{ lb}$$

$$\Sigma M_y = 0; \quad -\frac{6}{9}F_{DE}(3) + 180(3) = 0$$

$$F_{DE} = 270 \text{ lb} \quad \text{Ans}$$

$$\Sigma F_z = 0; \quad B_z + \frac{6}{9}(270) - 180 = 0$$

$$B_z = 0 \quad \text{Ans}$$

$$\Sigma(M_B)_x = 0; \quad -\frac{9}{\sqrt{97}}F_{AC}(3) - \frac{4}{\sqrt{97}}F_{AC}(9) + 135(1) + 200(3) - \frac{6}{9}(270)(3) - \frac{3}{9}(270)(1) = 0$$

$$F_{AC} = 16.41 \text{ lb}$$

$$\Sigma F_x = 0; \quad 135 - \frac{3}{9}(270) + B_x - \frac{9}{\sqrt{97}}(16.41) = 0$$

$$B_x = -30 \text{ lb} \quad \text{Ans}$$

$$\Sigma F_y = 0; \quad B_y - \frac{4}{\sqrt{97}}(16.41) + 200 - \frac{6}{9}(270) = 0$$

$$B_y = -13.3 \text{ lb} \quad \text{Ans}$$

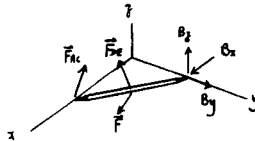

6-125. The four-member "A" frame is supported at A and E by smooth collars and at G by a pin. All the other joints are ball-and-sockets. If the pin at G will fail when the resultant force there is 800 N, determine the largest vertical force P that can be supported by the frame. Also, what are the x , y , z force components which member BD exerts on members EDC and ABC ? The collars at A and E and the pin at G only exert force components on the frame.

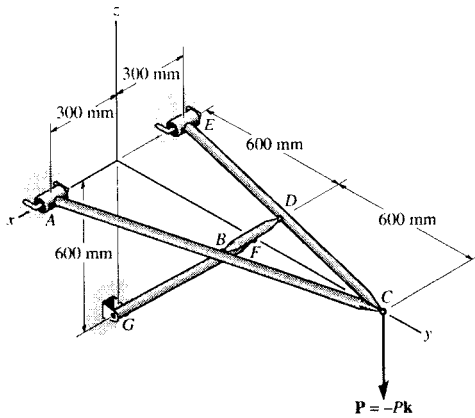

$$\Sigma M_x = 0; \quad -P(1.2) + 800 \sin 45^\circ (0.6) = 0$$

$$P = 471 \text{ N} \quad \text{Ans}$$

$$B_x + D_x = 800 \cos 45^\circ$$

$$B_x = D_x = 283 \text{ N} \quad \text{Ans}$$

$$B_y + D_y = 800 \sin 45^\circ$$

$$B_y D_y = 283 \text{ N} \quad \text{Ans}$$

$$B_z = D_z = 0 \quad \text{Ans}$$

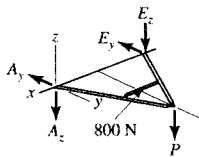

6-126. The structure is subjected to the loading shown. Member AD is supported by a cable AB and roller at C and fits through a smooth circular hole at D . Member ED is supported by a roller at D and a pole that fits in a smooth snug circular hole at E . Determine the x , y , z components of reaction at E and the tension in cable AB .

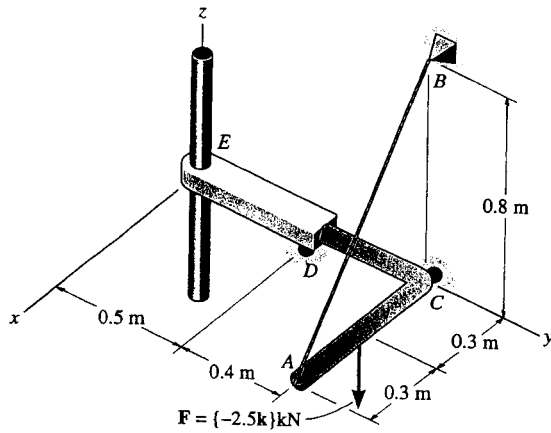

$$\begin{aligned} \Sigma M_y = 0; & \quad -\frac{4}{5}F_{AB}(0.6) + 2.5(0.3) = 0 \\ & \quad F_{AB} = 1.563 = 1.56 \text{ kN} \quad \text{Ans} \\ \Sigma F_z = 0; & \quad \frac{4}{5}(1.563) - 2.5 + D_z = 0 \\ & \quad D_z = 1.25 \text{ kN} \\ \Sigma F_y = 0; & \quad D_y = 0 \\ \Sigma F_x = 0; & \quad D_x + C_x - \frac{3}{5}(1.563) = 0 \quad (1) \\ \Sigma M_x = 0; & \quad M_{Dx} + \frac{4}{5}(1.563)(0.4) - 2.5(0.4) = 0 \\ & \quad M_{Dx} = 0.5 \text{ kN}\cdot\text{m} \\ \Sigma M_z = 0; & \quad M_{Dz} + \frac{3}{5}(1.563)(0.4) - C_x(0.4) = 0 \quad (2) \\ \Sigma F_z = 0; & \quad D_z = 1.25 \text{ kN} \\ \Sigma M_x = 0; & \quad M_{Dx} = 0.5 \text{ kN}\cdot\text{m} \quad \text{Ans} \\ \Sigma M_y = 0; & \quad M_{Dy} = 0 \quad \text{Ans} \\ \Sigma F_y = 0; & \quad E_y = 0 \quad \text{Ans} \\ \Sigma M_z = 0; & \quad D_x(0.5) - M_{Dz} = 0 \quad (3) \end{aligned}$$

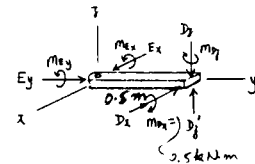
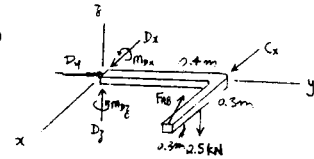

Solving Eqs. (1), (2) and (3) :

$$\begin{aligned} C_x &= 0.938 \text{ kN} \\ M_{Dz} &= 0 \\ D_x &= 0 \\ \Sigma F_x = 0; & \quad E_x = 0 \quad \text{Ans} \end{aligned}$$

$$\begin{aligned} (+\Sigma M_F = 0; & \quad F_{CD}(7) - \frac{4}{5}F_{BE}(2) = 0 \\ (+\Sigma M_A = 0; & \quad -150(7)(3.5) + \frac{4}{5}F_{BE}(5) - F_{CD}(7) = 0 \\ & \quad F_{BE} = 1531 \text{ lb} = 1.53 \text{ kip} \quad \text{Ans} \\ & \quad F_{CD} = 350 \text{ lb} \quad \text{Ans} \end{aligned}$$

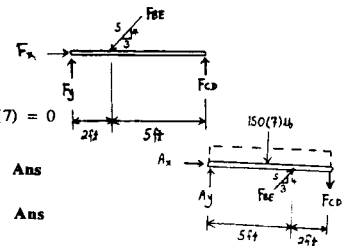

6-127. The structure is subjected to the force of 450 lb which lies in a plane parallel to the y - z plane. Member AB is supported by a ball-and-socket joint at A and fits through a snug hole at B . Member CD is supported by a pin at C . Determine the x , y , z components of reaction at A and C .

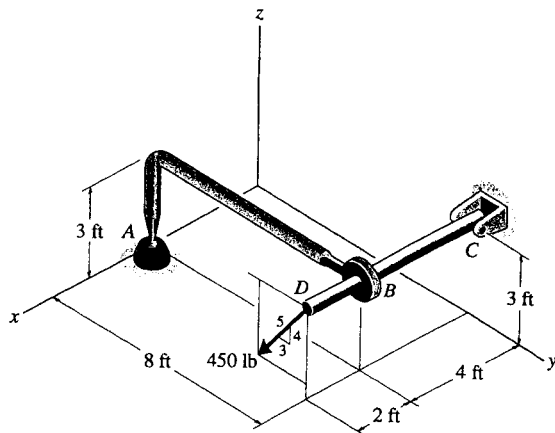

$$\begin{aligned} \Sigma M_x = 0; & \quad M_{Cx} = 0 & \quad \text{Ans} \\ \Sigma F_x = 0; & \quad C_x = 0 & \quad \text{Ans} \\ \Sigma F_y = 0; & \quad -450\left(\frac{3}{5}\right) + F_{BA}\left(\frac{8}{\sqrt{73}}\right) + C_y = 0 \\ \Sigma F_z = 0; & \quad C_z + F_{BA}\left(\frac{3}{\sqrt{73}}\right) - 450\left(\frac{4}{5}\right) = 0 \\ \Sigma M_y = 0; & \quad 450\left(\frac{4}{5}\right)(6) - F_{BA}\left(\frac{3}{\sqrt{73}}\right)(4) = 0 \\ \Sigma M_z = 0; & \quad M_{Cz} + F_{BA}\left(\frac{8}{\sqrt{73}}\right)(4) - 450\left(\frac{3}{5}\right)(6) = 0 \end{aligned}$$

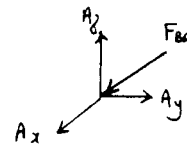
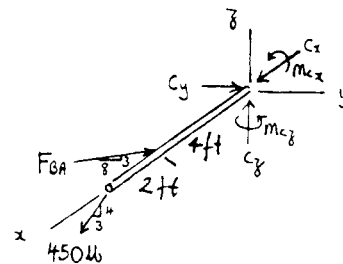

$$\begin{aligned} F_{BA} &= 1.538 \text{ kip} = 1.54 \text{ kip} & \quad \text{Ans} \\ C_z &= -0.18 \text{ kip} & \quad \text{Ans} \\ C_y &= -1.17 \text{ kip} & \quad \text{Ans} \\ M_{Cz} &= -4.14 \text{ kip}\cdot\text{ft} & \quad \text{Ans} \\ A_x &= 0 & \quad \text{Ans} \\ A_y &= 1.538\left(\frac{8}{\sqrt{73}}\right) = 1.44 \text{ kip} & \quad \text{Ans} \\ A_z &= 1.538\left(\frac{3}{\sqrt{73}}\right) = 0.540 \text{ kip} & \quad \text{Ans} \end{aligned}$$

*6-128. Determine the resultant forces at pins B and C on member ABC of the four-member frame.

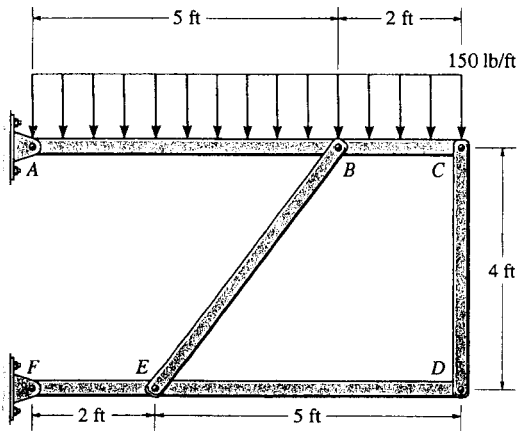

Prob. 6-128

$$(+\Sigma M_F = 0; \quad F_{CD}(7) - \frac{4}{5}F_{BE}(2) = 0$$

$$(+\Sigma M_A = 0; \quad -150(7)(3.5) + \frac{4}{5}F_{BE}(5) - F_{CD}(7) = 0$$

$$F_{BE} = 1531 \text{ lb} = 1.53 \text{ kip}$$

$$F_{CD} = 350 \text{ lb}$$

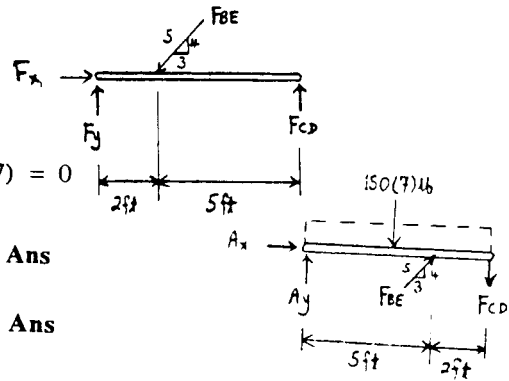

Ans

Ans

6-129. The mechanism consists of identical meshed gears A and B and arms which are fixed to the gears. The spring attached to the ends of the arms has an unstretched length of 100 mm and a stiffness of $k = 250$ N/m. If a torque of $M = 6$ N·m is applied to gear A , determine the angle θ through which each arm rotates. The gears are each pinned to fixed supports at their centers.

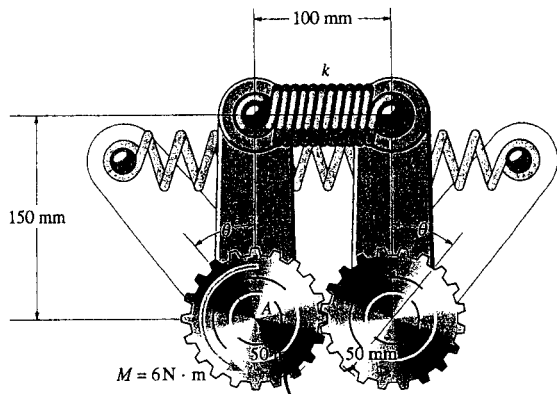

$$\zeta + \Sigma M_A = 0; \quad -F(0.05) - P(0.15 \cos \theta) + 6 = 0$$

$$\zeta + \Sigma M_B = 0; \quad P(0.15 \cos \theta) - F(0.05) = 0$$

$$2P(0.15 \cos \theta) = 6$$

$$2(2)(250)(0.15 \sin \theta)(0.15 \cos \theta) = 6$$

$$\sin 2\theta = 0.5333$$

$$\theta = 16.1^\circ \quad \text{Ans}$$

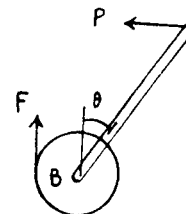
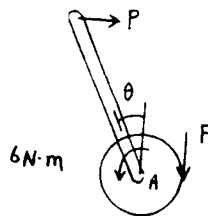

6-130. Determine the horizontal and vertical components of force at pins A and C of the two-member frame.

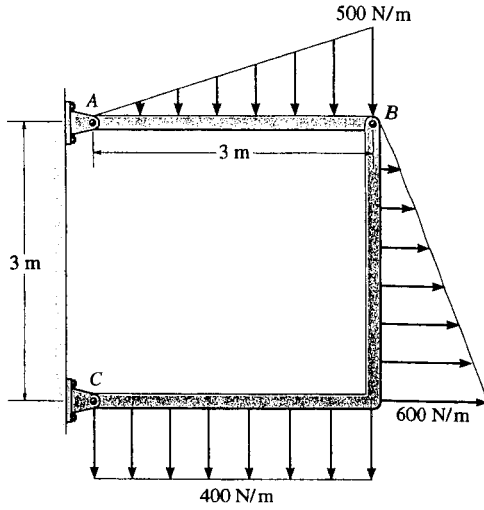

$$\curvearrowleft + \Sigma M_A = 0; \quad -750(2) + B_y(3) = 0$$

$$B_y = 500 \text{ N}$$

$$\curvearrowleft + \Sigma M_C = 0; \quad -1200(1.5) - 900(1) + B_x(3) - 500(3) = 0$$

$$B_x = 1400 \text{ N}$$

$$\rightarrow \Sigma F_x = 0; \quad -A_x + 1400 = 0$$

$$A_x = 1400 \text{ N} = 1.40 \text{ kN}$$

$$+\uparrow \Sigma F_y = 0; \quad A_y - 750 + 500 = 0$$

$$A_y = 250 \text{ N}$$

$$\rightarrow \Sigma F_x = 0; \quad C_x + 900 - 1400 = 0$$

$$C_x = 500 \text{ N}$$

$$+\uparrow \Sigma F_y = 0; \quad -500 - 1200 + C_y = 0$$

$$C_y = 1700 \text{ N} = 1.70 \text{ kN}$$

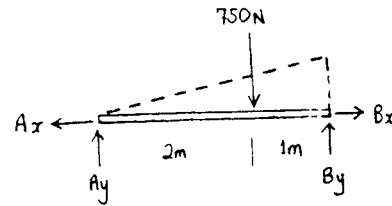

Ans

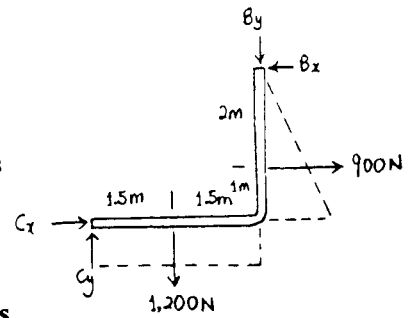

Ans

Ans

Ans

6-131. The spring has an unstretched length of 0.3 m. Determine the angle θ for equilibrium if the uniform links each have a mass of 5 kg.

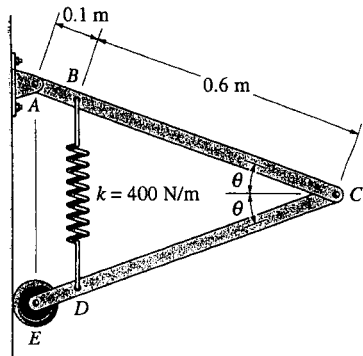

$$x = 0.6 \sin \theta$$

$$F_{BD} = 400[2(0.6) \sin \theta - 0.3]$$

$$= 480 \sin \theta - 120$$

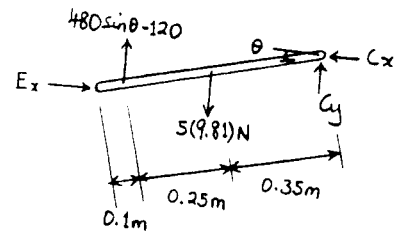
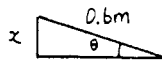

$$\zeta + \Sigma M_C = 0; \quad -(480 \sin \theta - 120)(0.6 \cos \theta) + E_x(0.7 \sin \theta) + 5(9.81)(0.35 \cos \theta) = 0$$

$$E_x = 411.4 \cos \theta - 127.4 \cot \theta$$

$$\zeta + \Sigma M_A = 0; \quad -5(9.81)(2)(0.35 \cos \theta) + (411.4 \cos \theta - 127.4 \cot \theta)(2)(0.7 \sin \theta) = 0$$

$$\sin \theta = \frac{212.7}{576}$$

$$\theta = 21.7^\circ \quad \text{Ans}$$

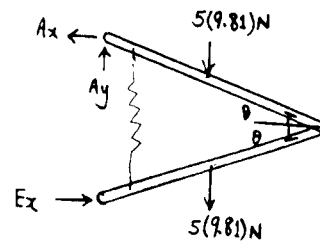

*6-132. The spring has an unstretched length of 0.3 m. Determine the mass m of each uniform link if the angle $\theta = 20^\circ$ for equilibrium.

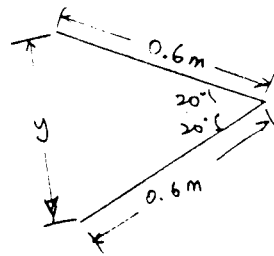
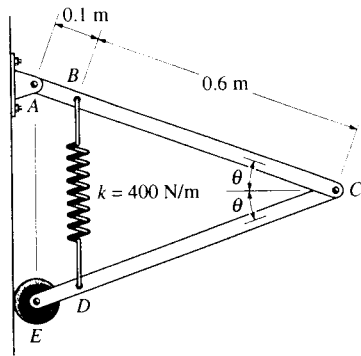

$$\frac{y}{2(0.6)} = \sin 20^\circ$$

$$y = 1.2 \sin 20^\circ$$

$$F_s = (1.2 \sin 20^\circ - 0.3)(400) = 44.1697 \text{ N}$$

$$\sum M_A = 0: E_y (1.4 \sin 20^\circ) - 2(mg)(0.35 \cos 20^\circ) = 0$$

$$E_y = 1.37374(mg)$$

$$\sum M_C = 0: 1.37374mg(0.7 \sin 20^\circ) + mg(0.35 \cos 20^\circ) - 44.1697(0.6 \cos 20^\circ) = 0$$

$$mg = 37.860$$

$$m = 37.860/9.81 = 3.86 \text{ kg} \quad \text{Ans}$$

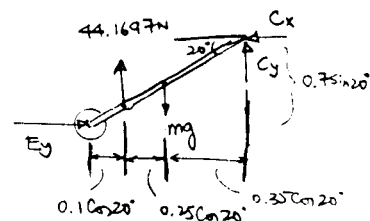
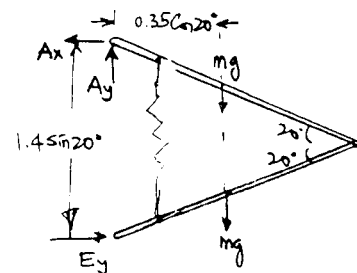

6-1.3. Determine the horizontal and vertical components of force that the pins A and B exert on the two-member frame. Set $F = 0$.

CB is a two-force member.

Member AC :

$$\sum M_A = 0; \quad -600(0.75) + 1.5(F_{CB} \sin 75^\circ) = 0$$

$$F_{CB} = 310.6$$

Thus,

$$B_x = B_y = 310.6 \left(\frac{1}{\sqrt{2}} \right) = 220 \text{ N} \quad \text{Ans}$$

$$\sum F_x = 0; \quad -A_x + 600 \sin 60^\circ - 310.6 \cos 45^\circ = 0$$

$$A_x = 300 \text{ N} \quad \text{Ans}$$

$$\sum F_y = 0; \quad A_y - 600 \cos 60^\circ + 310.6 \sin 45^\circ = 0$$

$$A_y = 80.4 \text{ N} \quad \text{Ans}$$

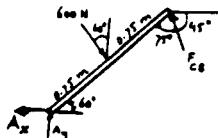
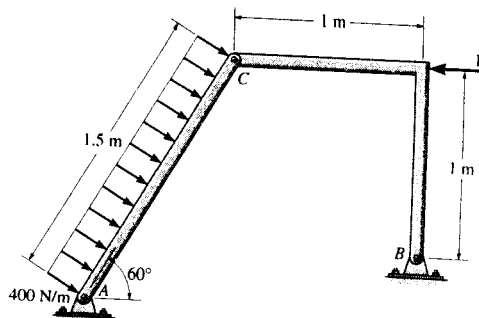

6-1.4. Determine the horizontal and vertical components of force that pins A and B exert on the two-member frame. Set $F = 500 \text{ N}$.

Member AC :

$$\sum M_A = 0; \quad -600(0.75) - C_x(1.5 \cos 60^\circ) + C_y(1.5 \sin 60^\circ) = 0$$

Member CB :

$$\sum M_B = 0; \quad -C_x(1) - C_y(1) + 500(1) = 0$$

Solving,

$$C_x = 402.6 \text{ N}$$

$$C_y = 97.4 \text{ N}$$

Member AC :

$$\sum F_x = 0; \quad -A_x + 600 \sin 60^\circ - 402.6 = 0$$

$$A_x = 117 \text{ N} \quad \text{Ans}$$

$$\sum F_y = 0; \quad A_y - 600 \cos 60^\circ - 97.4 = 0$$

$$A_y = 397 \text{ N} \quad \text{Ans}$$

Member CB :

$$\sum F_x = 0; \quad 402.6 - 500 + B_x = 0$$

$$B_x = 97.4 \text{ N} \quad \text{Ans}$$

$$\sum F_y = 0; \quad -B_y + 97.4 = 0$$

$$B_y = 97.4 \text{ N} \quad \text{Ans}$$

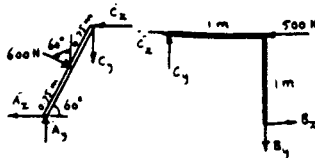
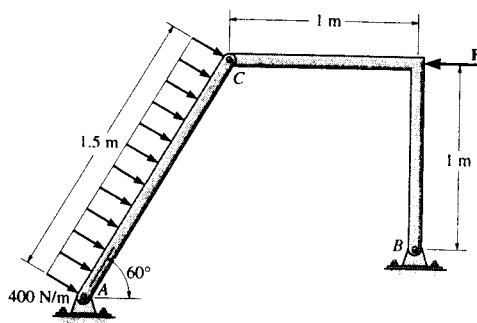

6-135. The two-bar mechanism consists of a lever arm AB and smooth link CD , which has a fixed collar at its end C and a roller at the other end D . Determine the force \mathbf{P} needed to hold the lever in the position θ . The spring has a stiffness k and unstretched length $2L$. The roller contacts either the top or bottom portion of the horizontal guide.

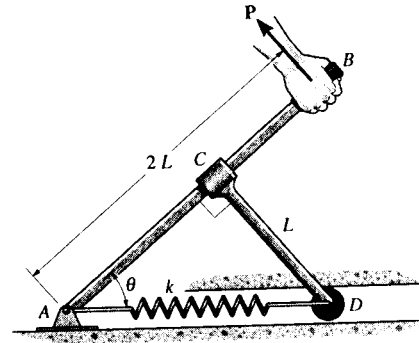

Free Body Diagram : The spring compresses $x = 2L - \frac{L}{\sin \theta}$. Then, the spring force developed is $F_{sp} = kx = kL\left(2 - \frac{1}{\sin \theta}\right)$.

Equations of Equilibrium : From FBD (a),

$$\rightarrow \Sigma F_x = 0; \quad kL\left(2 - \frac{1}{\sin \theta}\right) - F_{CD} \sin \theta = 0$$

$$F_{CD} = \frac{kL}{\sin \theta} \left(2 - \frac{1}{\sin \theta}\right)$$

$$+\Sigma M_D = 0; \quad M_C = 0$$

From FBD (b),

$$+\Sigma M_A = 0; \quad P(2L) - \frac{kL}{\sin \theta} \left(2 - \frac{1}{\sin \theta}\right) (L \cot \theta) = 0$$

$$P = \frac{kL}{2 \tan \theta \sin \theta} (2 - \csc \theta) \quad \text{Ans}$$

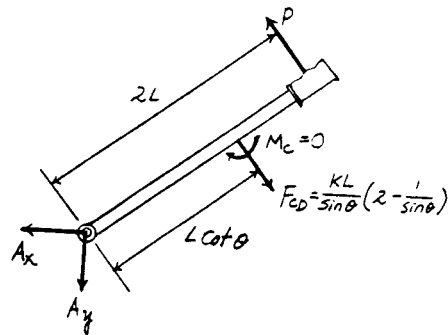
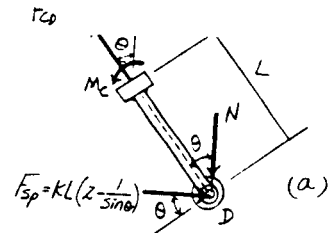

*6-136. Determine the force in each member of the truss and state if the members are in tension or compression.

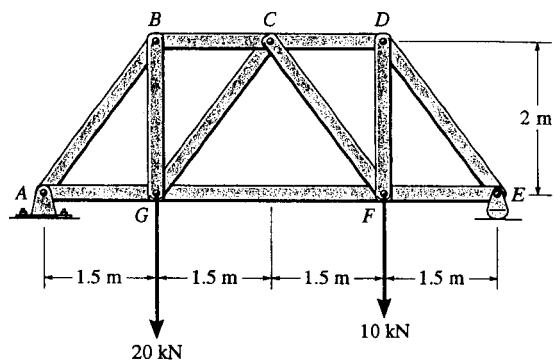

$$\curvearrow + \Sigma M_A = 0; \quad -20(1.5) - 10(4.5) + E_y(6) = 0$$

$$E_y = 12.5 \text{ kN}$$

$$\rightarrow \Sigma F_x = 0; \quad A_x = 0$$

$$+ \uparrow \Sigma F_y = 0; \quad A_y - 20 - 10 + 12.5 = 0$$

$$A_y = 17.5 \text{ kN}$$

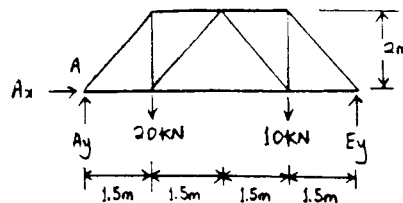

Joint A :

$$+ \uparrow \Sigma F_y = 0; \quad 17.5 - \frac{4}{5}F_{AB} = 0$$

$$F_{AB} = 21.88 = 21.9 \text{ kN (C)} \quad \text{Ans}$$

$$\rightarrow \Sigma F_x = 0; \quad F_{AG} - \frac{3}{5}(21.88) = 0$$

$$F_{AG} = 13.125 = 13.1 \text{ kN (T)} \quad \text{Ans}$$

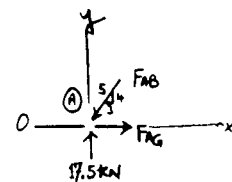

Joint B :

$$\rightarrow \Sigma F_x = 0; \quad -F_{BC} + \frac{3}{5}(21.88) = 0$$

$$F_{BC} = 13.1 \text{ kN (C)} \quad \text{Ans}$$

$$+ \uparrow \Sigma F_y = 0; \quad \frac{4}{5}(21.88) - F_{BG} = 0$$

$$F_{BG} = 17.5 \text{ kN (T)} \quad \text{Ans}$$

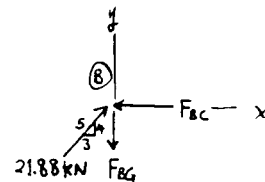

6-136 cont'd

Joint G:

$$+\uparrow \Sigma F_y = 0; \quad 17.5 - 20 + \frac{4}{5}F_{GC} = 0$$

$$F_{GC} = 3.125 = 3.12 \text{ kN (T)} \quad \text{Ans}$$

$$\rightarrow \Sigma F_x = 0; \quad \frac{3}{5}(3.125) + F_{GF} - 13.125 = 0$$

$$F_{GF} = 11.2 \text{ kN (T)} \quad \text{Ans}$$

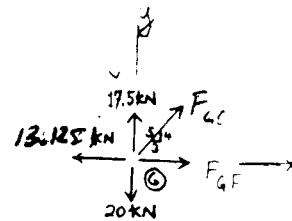

Joint C:

$$+\uparrow \Sigma F_y = 0; \quad \frac{4}{5}F_{CF} - \frac{4}{5}(3.125) = 0$$

$$F_{CF} = 3.12 \text{ kN (C)} \quad \text{Ans}$$

$$\rightarrow \Sigma F_x = 0; \quad 13.12 - \frac{3}{5}(3.125) - \frac{3}{5}(3.125) - F_{CD} = 0$$

$$F_{CD} = 9.375 = 9.38 \text{ kN (C)} \quad \text{Ans}$$

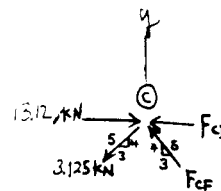

Joint D:

$$\rightarrow \Sigma F_x = 0; \quad 9.375 - \frac{3}{5}(F_{DE}) = 0$$

$$F_{DE} = 15.63 = 15.6 \text{ kN (C)} \quad \text{Ans}$$

$$+\uparrow \Sigma F_y = 0; \quad \frac{4}{5}(15.63) - F_{DF} = 0$$

$$F_{DF} = 12.5 \text{ kN (T)} \quad \text{Ans}$$

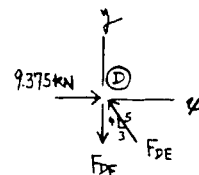

Joint F:

$$\rightarrow \Sigma F_x = 0; \quad \frac{3}{5}(3.125) - 11.25 + F_{EF} = 0$$

$$F_{EF} = 9.38 \text{ kN (T)} \quad \text{Ans}$$

$$+\uparrow \Sigma F_y = 0; \quad 12.5 - 10 - \frac{4}{5}(3.125) = 0 \quad \text{Check!}$$

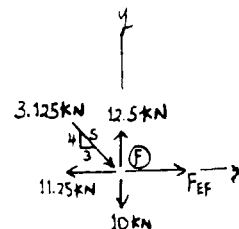

6-137. Determine the force in members AB , AD , and AC of the space truss and state if the members are in tension or compression.

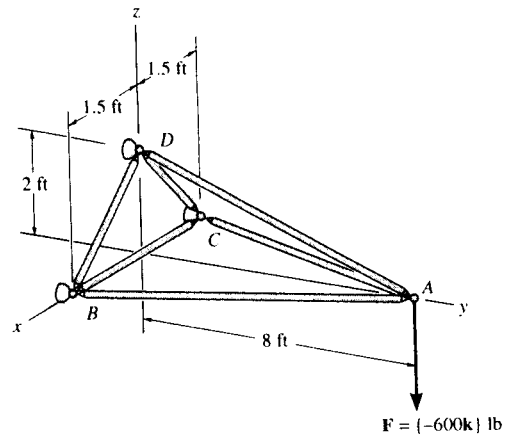

Method of Joints : In this case the support reactions are not required for determining the member forces.

Joint A

$$\Sigma F_z = 0; \quad F_{AD} \left(\frac{2}{\sqrt{68}} \right) - 600 = 0$$

$$F_{AD} = 2473.86 \text{ lb (T)} = 2.47 \text{ kip (T)} \quad \text{Ans}$$

$$\Sigma F_x = 0; \quad F_{AC} \left(\frac{1.5}{\sqrt{66.25}} \right) - F_{AB} \left(\frac{1.5}{\sqrt{66.25}} \right) = 0$$

$$F_{AC} = F_{AB} \quad [1]$$

$$\Sigma F_y = 0; \quad F_{AC} \left(\frac{8}{\sqrt{66.25}} \right) + F_{AB} \left(\frac{8}{\sqrt{66.25}} \right) - 2473.86 \left(\frac{8}{\sqrt{68}} \right) = 0$$

$$0.9829 F_{AC} + 0.9829 F_{AB} = 2400 \quad [2]$$

Solving Eqs. [1] and [2] yields

$$F_{AC} = F_{AB} = 1220.91 \text{ lb (C)} = 1.22 \text{ kip (C)} \quad \text{Ans}$$

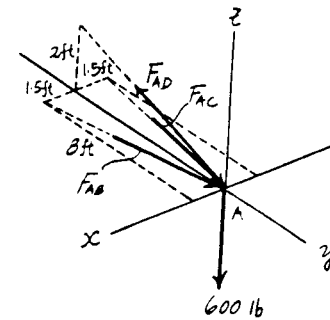

7-1. The column is fixed to the floor and is subjected to the loads shown. Determine the internal normal force, shear force, and moment at points A and B.

Free body Diagram : The support reaction need not be computed in this case.

Internal Forces : Applying equations of equilibrium to the top segment sectioned through point A, we have

$$\rightarrow \Sigma F_x = 0; \quad V_A = 0 \quad \text{Ans}$$

$$+ \uparrow \Sigma F_y = 0; \quad N_A - 6 - 6 = 0 \quad N_A = 12.0 \text{ kN} \quad \text{Ans}$$

$$\curvearrowleft + \Sigma M_A = 0; \quad 6(0.15) - 6(0.15) - M_A = 0 \quad M_A = 0 \quad \text{Ans}$$

Applying equations of equilibrium to the top segment sectioned through point B, we have

$$\rightarrow \Sigma F_x = 0; \quad V_B = 0 \quad \text{Ans}$$

$$+ \uparrow \Sigma F_y = 0; \quad N_B - 6 - 6 - 8 = 0 \quad N_B = 20.0 \text{ kN} \quad \text{Ans}$$

$$+ \Sigma M_B = 0; \quad 6(0.15) - 6(0.15) - 8(0.15) + M_B = 0 \\ M_B = 1.20 \text{ kN} \cdot \text{m} \quad \text{Ans}$$

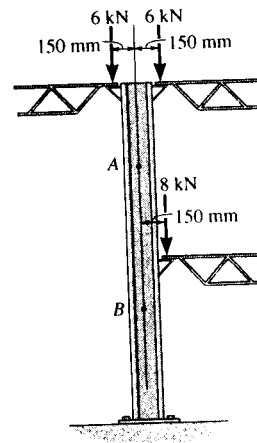
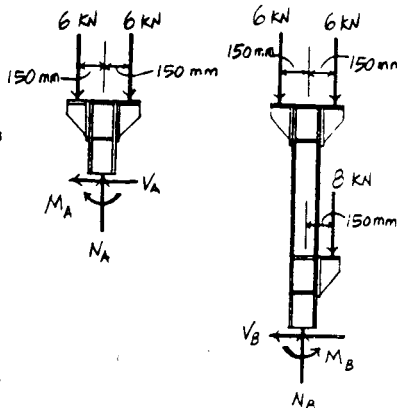

7-2. The rod is subjected to the forces shown. Determine the internal normal force at points A, B, and C.

Free body Diagram : The support reaction need not be computed in this case.

Internal Forces : Applying equations of equilibrium to the top segment sectioned through point A, we have

$$+ \uparrow \Sigma F_y = 0; \quad N_A - 550 = 0 \quad N_A = 550 \text{ lb} \quad \text{Ans}$$

Applying equations of equilibrium to the top segment sectioned through point B, we have

$$+ \uparrow \Sigma F_y = 0; \quad N_B - 550 + 150 + 150 = 0 \\ N_B = 250 \text{ lb} \quad \text{Ans}$$

Applying equations of equilibrium to the top segment sectioned through point C, we have

$$+ \uparrow \Sigma F_y = 0; \quad N_C - 550 + 150 + 150 - 350 - 350 = 0 \\ N_C = 950 \text{ lb} \quad \text{Ans}$$

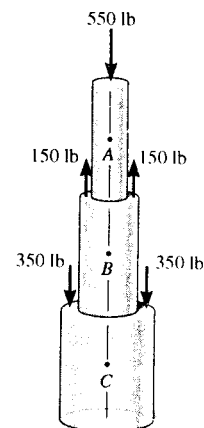
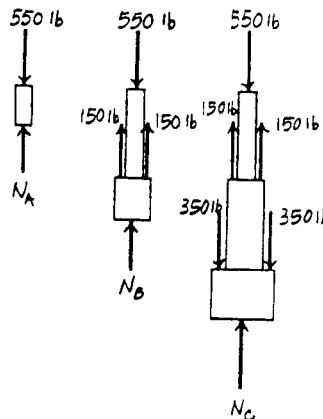

7-3. The forces act on the shaft shown. Determine the internal normal force at points A, B, and C.

Internal Forces : Applying the equation of equilibrium to the left segment sectioned through point A, we have

$$\rightarrow \Sigma F_x = 0; \quad N_A - 5 = 0 \quad N_A = 5.00 \text{ kN} \quad \text{Ans}$$

Applying the equation of equilibrium to the right segment sectioned through point B, we have

$$\rightarrow \Sigma F_x = 0; \quad 4 - N_C = 0 \quad N_C = 4.00 \text{ kN} \quad \text{Ans}$$

Applying the equation of equilibrium to the right segment sectioned through point C, we have

$$\rightarrow \Sigma F_x = 0; \quad N_B + 4 - 7 = 0 \quad N_B = 3.00 \text{ kN} \quad \text{Ans}$$

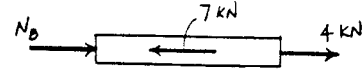
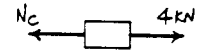
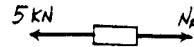
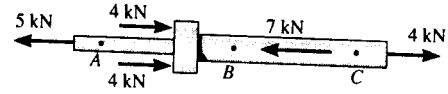

*7-4. The shaft is supported by the two smooth bearings A and B. The four pulleys attached to the shaft are used to transmit power to adjacent machinery. If the torques applied to the pulleys are as shown, determine the internal torques at points C, D, and E.

Internal Forces : Applying the equation of equilibrium to the left segment sectioned through point C, we have

$$\Sigma M_x = 0; \quad 40 - T_C = 0 \quad T_C = 40.0 \text{ lb} \cdot \text{ft} \quad \text{Ans}$$

Applying the equation of equilibrium to the left segment sectioned through point D, we have

$$\Sigma M_x = 0; \quad 40 + 15 - T_D = 0 \quad T_D = 55.0 \text{ lb} \cdot \text{ft} \quad \text{Ans}$$

Applying the equation of equilibrium to the right segment sectioned through point E, we have

$$\Sigma M_x = 0; \quad 10 - T_E = 0 \quad T_E = 10.0 \text{ lb} \cdot \text{ft} \quad \text{Ans}$$

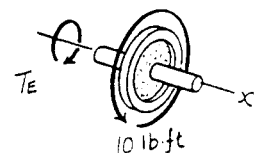
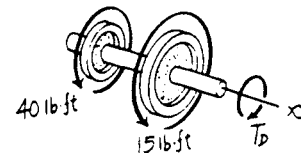
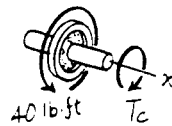
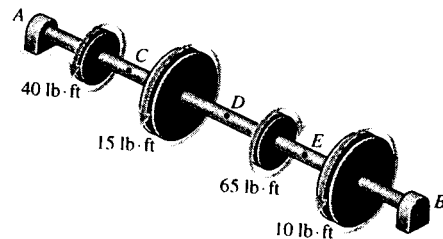

7-5. The shaft is supported by a journal bearing at A and a thrust bearing at B . Determine the normal force, shear force, and moment at a section passing through (a) point C , which is just to the right of the bearing at A , and (b) point D , which is just to the left of the 3000-lb force.

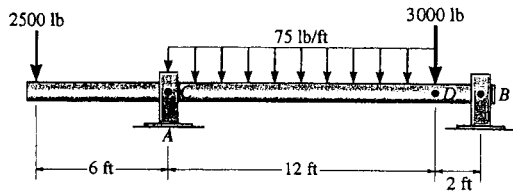

Prob. 7-5

$$\curvearrowleft + \Sigma M_B = 0; \quad -A_y(14) + 2500(20) + 900(8) + 3000(2) = 0$$

$$A_y = 4514 \text{ lb}$$

$$\rightarrow \Sigma F_x = 0; \quad B_x = 0$$

$$+ \uparrow \Sigma F_y = 0; \quad 4514 - 2500 - 900 - 3000 + B_y = 0$$

$$B_y = 1886 \text{ lb}$$

$$\curvearrowleft + \Sigma M_C = 0; \quad 2500(6) + M_C = 0$$

$$M_C = -15000 \text{ lb}\cdot\text{ft} = -15.0 \text{ kip}\cdot\text{ft}$$

$$\rightarrow \Sigma F_x = 0; \quad N_C = 0$$

$$+ \uparrow \Sigma F_y = 0; \quad -2500 + 4514 - V_C = 0$$

$$V_C = 2014 \text{ lb} = 2.01 \text{ kip}$$

$$\curvearrowleft + \Sigma M_D = 0; \quad -M_D + 1886(2) = 0$$

$$M_D = 3771 \text{ lb}\cdot\text{ft} = 3.77 \text{ kip}\cdot\text{ft}$$

$$\rightarrow \Sigma F_x = 0; \quad N_D = 0$$

$$+ \uparrow \Sigma F_y = 0; \quad V_D - 3000 + 1886 = 0$$

$$V_D = 1114 \text{ lb} = 1.11 \text{ kip}$$

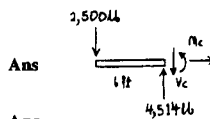
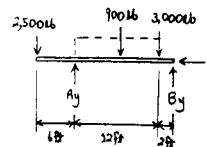

Ans

Ans

Ans

Ans

Ans

Ans

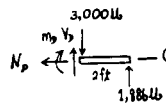

Ans

7-6. Determine the internal normal force and shear force, and the bending moment in the beam at points C and D. Assume the support at B is a roller. Point C is located just to the right of the 8-kip load.

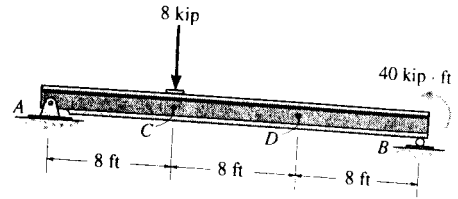

Support Reactions : FBD (a).

$$\begin{aligned} \left(+ \Sigma M_A = 0; \quad B_y(24) + 40 - 8(8) = 0 \quad B_y = 1.00 \text{ kip} \right. \\ \left. + \uparrow \Sigma F_y = 0; \quad A_y + 1.00 - 8 = 0 \quad A_y = 7.00 \text{ kip} \right. \\ \left. \rightarrow \Sigma F_x = 0 \quad A_x = 0 \right. \end{aligned}$$

Internal Forces : Applying the equations of equilibrium to segment AC [FBD (b)], we have

$$\rightarrow \Sigma F_x = 0; \quad N_C = 0 \quad \text{Ans}$$

$$+ \uparrow \Sigma F_y = 0; \quad 7.00 - 8 - V_C = 0 \quad V_C = -1.00 \text{ kip} \quad \text{Ans}$$

$$\left(+ \Sigma M_C = 0; \quad M_C - 7.00(8) = 0 \quad M_C = 56.0 \text{ kip} \cdot \text{ft} \quad \text{Ans} \right.$$

Applying the equations of equilibrium to segment BD [FBD (c)], we have

$$\rightarrow \Sigma F_x = 0; \quad N_D = 0 \quad \text{Ans}$$

$$+ \uparrow \Sigma F_y = 0; \quad V_D + 1.00 = 0 \quad V_D = -1.00 \text{ kip} \quad \text{Ans}$$

$$\left(+ \Sigma M_D = 0; \quad 1.00(8) + 40 - M_D = 0 \right. \\ \left. M_D = 48.0 \text{ kip} \cdot \text{ft} \quad \text{Ans} \right.$$

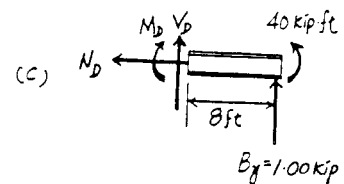
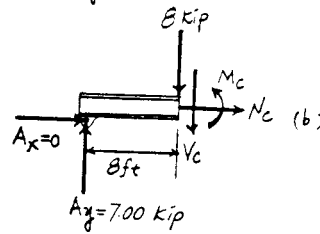
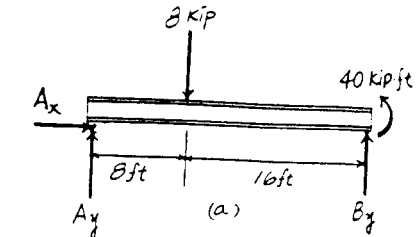

7-7. Determine the shear force and moment at points C and D.

Support Reactions : FBD (a).

$$\left(+ \Sigma M_B = 0; \quad 500(8) - 300(8) - A_y(14) = 0 \right. \\ \left. A_y = 114.29 \text{ lb} \right.$$

Internal Forces : Applying the equations of equilibrium to segment AC [FBD (b)], we have

$$\rightarrow \Sigma F_x = 0; \quad N_C = 0 \quad \text{Ans}$$

$$+ \uparrow \Sigma F_y = 0; \quad 114.29 - 500 - V_C = 0 \quad V_C = -386 \text{ lb} \quad \text{Ans}$$

$$\left(+ \Sigma M_C = 0; \quad M_C + 500(4) - 114.29(10) = 0 \right. \\ \left. M_C = -857 \text{ lb} \cdot \text{ft} \quad \text{Ans} \right.$$

Applying the equations of equilibrium to segment ED [FBD (c)], we have

$$\rightarrow \Sigma F_x = 0; \quad N_D = 0 \quad \text{Ans}$$

$$+ \uparrow \Sigma F_y = 0; \quad V_D - 300 = 0 \quad V_D = 300 \text{ lb} \quad \text{Ans}$$

$$\left(+ \Sigma M_D = 0; \quad -M_D - 300(2) = 0 \quad M_D = -600 \text{ lb} \cdot \text{ft} \quad \text{Ans} \right.$$

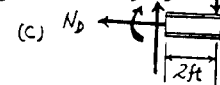
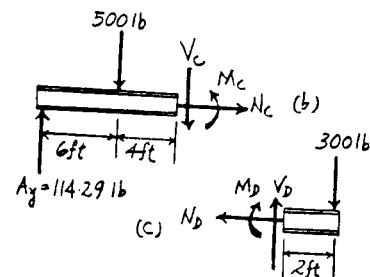
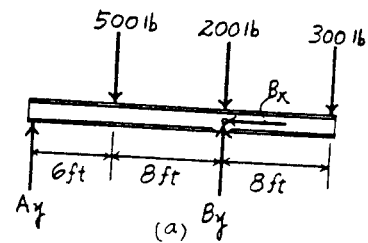
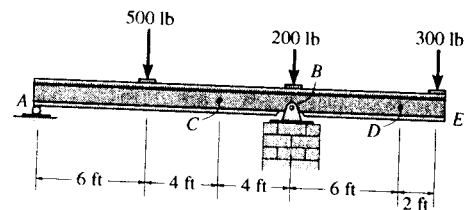

*7-8. Determine the normal force, shear force, and moment at a section passing through point C. Assume the support at A can be approximated by a pin and B as a roller.

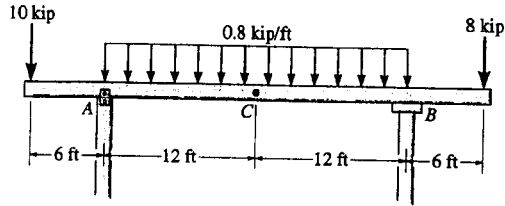

$$\begin{aligned} \zeta + \Sigma M_A = 0; & \quad -19.2(12) - 8(30) + B_y(24) + 10(6) = 0 \\ & \quad B_y = 17.1 \text{ kip} \\ \rightarrow \Sigma F_x = 0; & \quad A_x = 0 \\ + \uparrow \Sigma F_y = 0; & \quad A_y - 10 - 19.2 + 17.1 - 8 = 0 \\ & \quad A_y = 20.1 \text{ kip} \\ \rightarrow \Sigma F_x = 0; & \quad N_C = 0 \quad \text{Ans} \\ + \uparrow \Sigma F_y = 0; & \quad V_C - 9.6 + 17.1 - 8 = 0 \\ & \quad V_C = 0.5 \text{ kip} \quad \text{Ans} \\ \zeta + \Sigma M_C = 0; & \quad -M_C - 9.6(6) + 17.1(12) - 8(18) = 0 \\ & \quad M_C = 3.6 \text{ kip}\cdot\text{ft} \quad \text{Ans} \end{aligned}$$

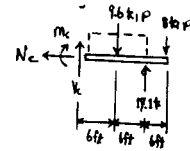
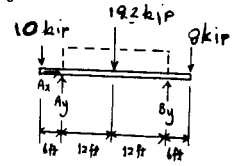

7-9. Determine the normal force, shear force, and moment at a section passing through point D. Take $w = 150 \text{ N/m}$.

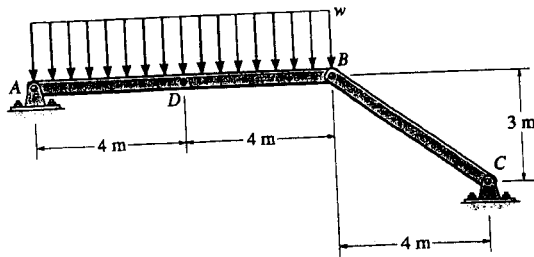

$$\begin{aligned} \zeta + \Sigma M_A = 0; & \quad -150(8)(4) + \frac{3}{5}F_{BC}(8) = 0 \\ & \quad F_{BC} = 1000 \text{ N} \\ \rightarrow \Sigma F_x = 0; & \quad A_x - \frac{4}{5}(1000) = 0 \\ & \quad A_x = 800 \text{ N} \\ + \uparrow \Sigma F_y = 0; & \quad A_y - 150(8) + \frac{3}{5}(1000) = 0 \\ & \quad A_y = 600 \text{ N} \\ \rightarrow \Sigma F_x = 0; & \quad N_D = -800 \text{ N} \\ + \uparrow \Sigma F_y = 0; & \quad 600 - 150(4) - V_D = 0 \\ & \quad V_D = 0 \\ \zeta + \Sigma M_D = 0; & \quad -600(4) + 150(4)(2) + M_D = 0 \\ & \quad M_D = 1200 \text{ N}\cdot\text{m} = 1.20 \text{ kN}\cdot\text{m} \quad \text{Ans} \end{aligned}$$

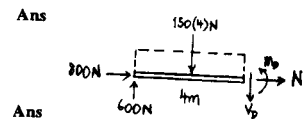
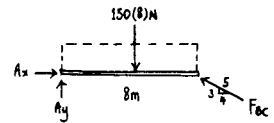

7-10. The beam AB will fail if the maximum internal moment at D reaches $800 \text{ N}\cdot\text{m}$ or the normal force in member BC becomes 1500 N . Determine the largest load w it can support.

Assume maximum moment occurs at D ;

$$\zeta + \Sigma M_D = 0; \quad M_D - 4w(2) = 0$$

$$800 = 4w(2)$$

$$w = 100 \text{ N/m}$$

$$\zeta + \Sigma M_A = 0; \quad -800(4) + T_{BC}(0.6)(8) = 0$$

$$T_{BC} = 666.7 \text{ N} < 1500 \text{ N} \quad (\text{O.K.})$$

$$w = 100 \text{ N/m}$$

Ans

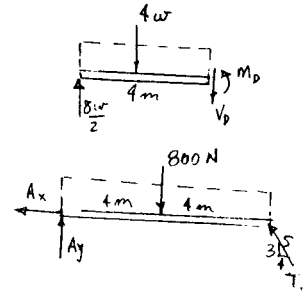
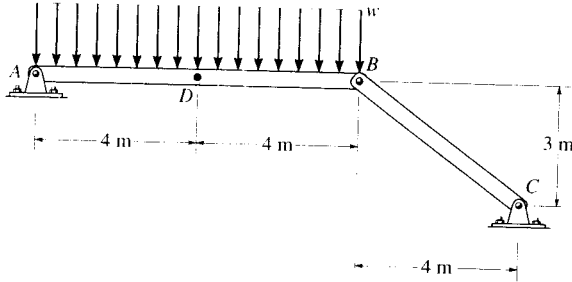

7-11. Determine the shear force and moment acting at a section passing through point C in the beam.

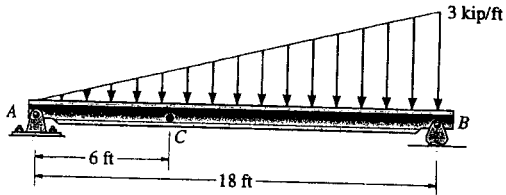

$$\zeta + \Sigma M_B = 0; \quad -A_y(18) + 27(6) = 0$$

$$A_y = 9 \text{ kip}$$

$$\rightarrow \Sigma F_x = 0; \quad A_x = 0$$

$$\zeta + \Sigma M_C = 0; \quad -9(6) + 3(2) + M_C = 0$$

$$M_C = 48 \text{ kip}\cdot\text{ft} \quad \text{Ans}$$

$$+ \uparrow \Sigma F_y = 0; \quad 9 - 3 - V_C = 0$$

$$V_C = 6 \text{ kip} \quad \text{Ans}$$

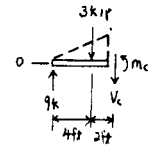
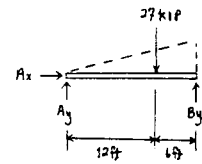

*7-12. The boom DF of the jib crane and the column DE have a uniform weight of 50 lb/ft. If the hoist and load weigh 300 lb, determine the normal force, shear force, and moment in the crane at sections passing through points A , B , and C .

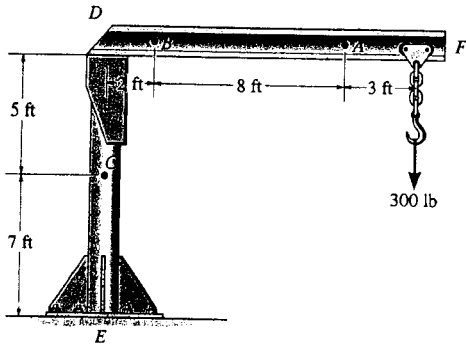

$$\begin{aligned} \rightarrow \Sigma F_x = 0; \quad N_A &= 0 && \text{Ans} \\ + \uparrow \Sigma F_y = 0; \quad V_A - 450 &= 0; \quad V_A = 450 \text{ lb} && \text{Ans} \\ \curvearrowright + \Sigma M_A = 0; \quad M_A - 150(1.5) - 300(3) &= 0; \quad M_A = 1125 \text{ lb}\cdot\text{ft} && \text{Ans} \\ \rightarrow \Sigma F_x = 0; \quad N_B &= 0 && \text{Ans} \\ + \uparrow \Sigma F_y = 0; \quad V_B - 550 - 300 &= 0; \quad V_B = 850 \text{ lb} && \text{Ans} \\ \curvearrowright + \Sigma M_B = 0; \quad M_B - 550(5.5) - 300(11) &= 0; \quad M_B = 6325 \text{ lb}\cdot\text{ft} && \text{Ans} \\ \rightarrow \Sigma F_x = 0; \quad V_C &= 0 && \text{Ans} \\ + \uparrow \Sigma F_y = 0; \quad N_C - 650 - 300 - 250 &= 0; \quad N_C = 1200 \text{ lb} && \text{Ans} \\ \curvearrowright + \Sigma M_C = 0; \quad M_C - 650(6.5) - 300(13) &= 0; \quad M_C = 8125 \text{ lb}\cdot\text{ft} && \text{Ans} \end{aligned}$$

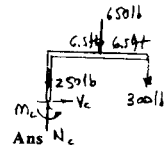
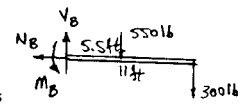
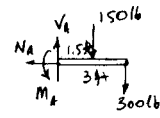

7-13. Determine the internal normal force, shear force, and moment acting at point C and at point D , which is located just to the right of the roller support at B .

Support Reactions : From FBD (a),

$$\begin{aligned} \curvearrowright + \Sigma M_A = 0; \quad B_y(8) + 800(2) - 2400(4) - 800(10) &= 0 \\ B_y &= 2000 \text{ lb} \end{aligned}$$

Internal Forces : Applying the equations of equilibrium to segment ED [FBD (b)], we have

$$\begin{aligned} \rightarrow \Sigma F_x = 0; \quad N_D &= 0 && \text{Ans} \\ + \uparrow \Sigma F_y = 0; \quad V_D - 800 &= 0 \quad V_D = 800 \text{ lb} && \text{Ans} \\ \curvearrowright + \Sigma M_D = 0; \quad -M_D - 800(2) &= 0 \\ M_D &= -1600 \text{ lb}\cdot\text{ft} = -1.60 \text{ kip}\cdot\text{ft} && \text{Ans} \end{aligned}$$

Applying the equations of equilibrium to segment EC [FBD (c)], we have

$$\begin{aligned} \rightarrow \Sigma F_x = 0; \quad N_C &= 0 && \text{Ans} \\ + \uparrow \Sigma F_y = 0; \quad V_C + 2000 - 1200 - 800 &= 0 \quad V_C = 0 && \text{Ans} \\ \curvearrowright + \Sigma M_C = 0; \quad 2000(4) - 1200(2) - 800(6) - M_C &= 0 \\ M_C &= 800 \text{ lb}\cdot\text{ft} && \text{Ans} \end{aligned}$$

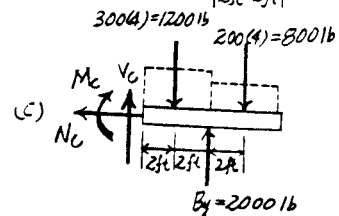
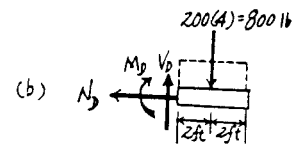
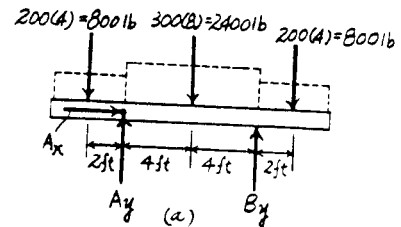
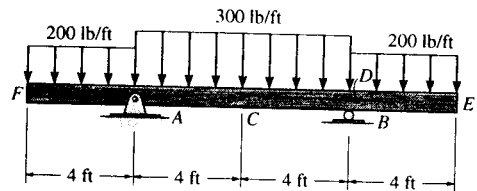

7-14. Determine the normal force, shear force, and moment at a section passing through point D of the two-member frame.

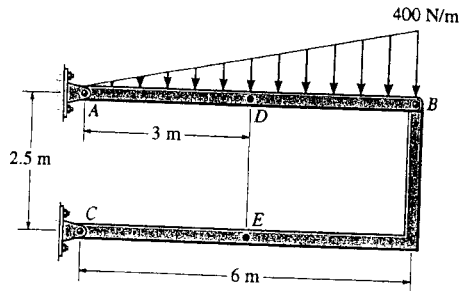

$$\zeta + \Sigma M_A = 0; \quad -1200(4) + \frac{5}{13} F_{BC}(6) = 0$$

$$F_{BC} = 2080 \text{ N}$$

$$\rightarrow \Sigma F_x = 0; \quad \frac{12}{13}(2080) - A_x = 0$$

$$A_x = 1920 \text{ N}$$

$$+\uparrow \Sigma F_y = 0; \quad A_y - 1200 + \frac{5}{13}(2080) = 0$$

$$A_y = 400 \text{ N}$$

$$\rightarrow \Sigma F_x = 0; \quad N_D = 1920 \text{ N} = 1.92 \text{ kN}$$

$$+\uparrow \Sigma F_y = 0; \quad 400 - 300 - V_D = 0$$

$$V_D = 100 \text{ N}$$

$$\zeta + \Sigma M_D = 0; \quad -400(3) + 300(1) + M_D = 0$$

$$M_D = 900 \text{ N}\cdot\text{m}$$

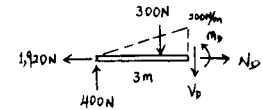
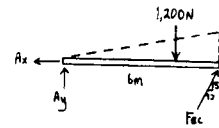

Ans

Ans

Ans

7-15. Determine the normal force, shear force, and moment at a section passing through point E of the two-member frame.

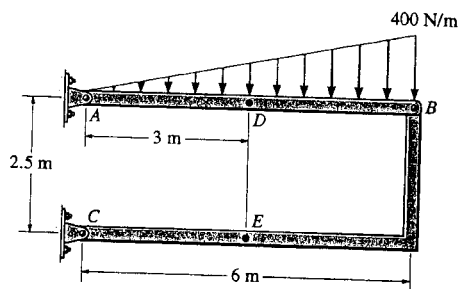

$$\zeta + \Sigma M_A = 0; \quad -1200(4) - \frac{5}{13} F_{BC}(6) = 0$$

$$F_{BC} = 2080 \text{ N}$$

$$\rightarrow \Sigma F_x = 0; \quad -N_E - \frac{12}{13}(2080) = 0$$

$$N_E = -1920 \text{ N} = -1.92 \text{ kN}$$

Ans

$$+\uparrow \Sigma F_y = 0; \quad V_E - \frac{5}{13}(2080) = 0$$

$$V_E = 800 \text{ N}$$

Ans

$$\zeta + \Sigma M_E = 0; \quad -\frac{5}{13}(2080)(3) + \frac{12}{13}(2080)(2.5) - M_E = 0$$

$$M_E = 2400 \text{ N}\cdot\text{m} = 2.40 \text{ kN}\cdot\text{m}$$

Ans

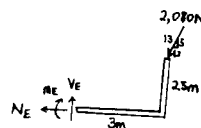
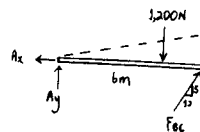

7-16. The strongback or lifting beam is used for materials handling. If the suspended load has a weight of 2 kN and a center of gravity of G , determine the placement d of the padeyes on the top of the beam so that there is no moment developed within the length AB of the beam. The lifting bridle has two legs that are positioned at 45° , as shown.

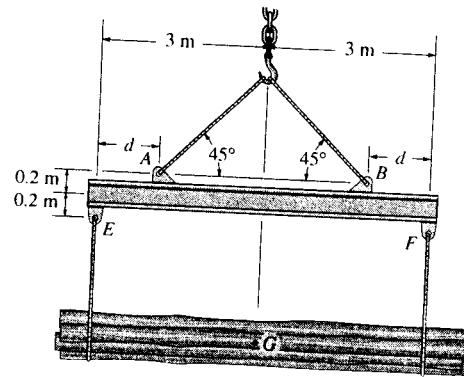

Support Reactions : From FBD (a),

$$\begin{aligned} \curvearrowleft + \Sigma M_E = 0; & \quad F_F(6) - 2(3) = 0 & \quad F_F = 1.00 \text{ kN} \\ + \uparrow \Sigma F_y = 0; & \quad F_F + 1.00 - 2 = 0 & \quad F_F = 1.00 \text{ kN} \end{aligned}$$

From FBD (b),

$$\begin{aligned} \rightarrow \Sigma F_x = 0; & \quad F_{AC} \cos 45^\circ - F_{BC} \cos 45^\circ = 0 & \quad F_{AC} = F_{BC} = F \\ + \uparrow \Sigma F_y = 0; & \quad 2F \sin 45^\circ - 1.00 - 1.00 = 0 \\ & \quad F_{AC} = F_{BC} = F = 1.414 \text{ kN} \end{aligned}$$

Internal Forces : This problem requires $M_H = 0$. Summing moments about point H of segment EH [FBD (c)], we have

$$\begin{aligned} \curvearrowleft + \Sigma M_H = 0; & \quad 1.00(d+x) - 1.414 \sin 45^\circ(x) \\ & \quad - 1.414 \cos 45^\circ(0.2) = 0 \\ & \quad d = 0.200 \text{ m} \quad \text{Ans} \end{aligned}$$

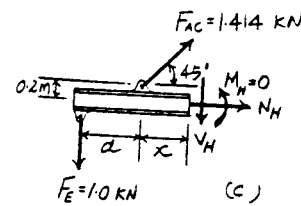
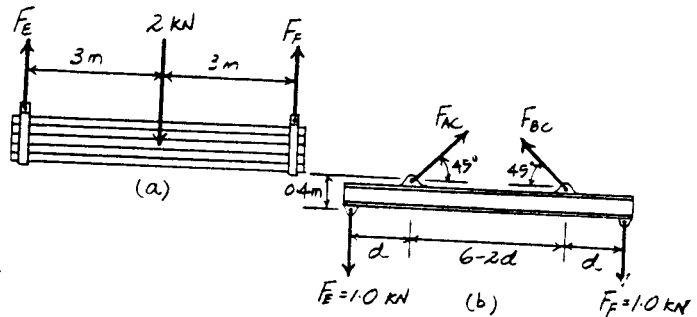

7-17. Determine the normal force, shear force, and moment acting at a section passing through point C.

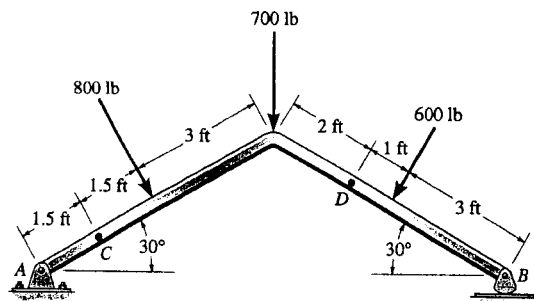

$$\zeta + \Sigma M_A = 0;$$

$$-800(3) - 700(6 \cos 30^\circ) - 600 \cos 30^\circ(6 \cos 30^\circ + 3 \cos 30^\circ) + 600 \sin 30^\circ(3 \sin 30^\circ) + B_y(6 \cos 30^\circ + 6 \cos 30^\circ) = 0$$

$$B_y = 927.4 \text{ lb}$$

$$\rightarrow \Sigma F_x = 0;$$

$$800 \sin 30^\circ - 600 \sin 30^\circ - A_x = 0$$

$$A_x = 100 \text{ lb}$$

$$\uparrow \Sigma F_y = 0;$$

$$A_y - 800 \cos 30^\circ - 700 - 600 \cos 30^\circ + 927.4 = 0$$

$$A_y = 985.1 \text{ lb}$$

$$\swarrow \Sigma F_x = 0;$$

$$N_C - 100 \cos 30^\circ + 985.1 \sin 30^\circ = 0$$

$$N_C = -406 \text{ lb} \quad \text{Ans}$$

$$\nwarrow \Sigma F_y = 0;$$

$$100 \sin 30^\circ + 985.1 \cos 30^\circ - V_C = 0$$

$$V_C = 903 \text{ lb} \quad \text{Ans}$$

$$\zeta + \Sigma M_C = 0;$$

$$-985.1(1.5 \cos 30^\circ) - 100(1.5 \sin 30^\circ) + M_C = 0$$

$$M_C = 1355 \text{ lb}\cdot\text{ft} = 1.35 \text{ kip}\cdot\text{ft} \quad \text{Ans}$$

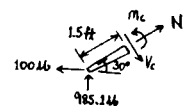
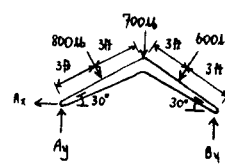

7-18. Determine the normal force, shear force, and moment acting at a section passing through point D.

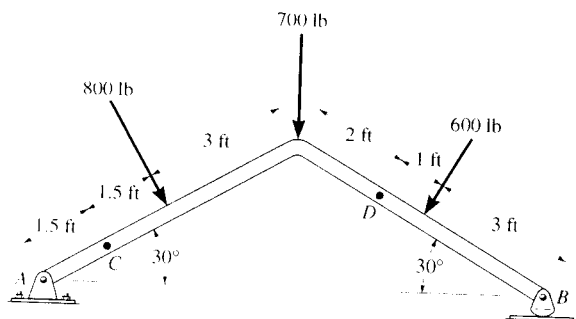

$$\zeta + \Sigma M_A = 0;$$

$$-800(3) - 700(6 \cos 30^\circ) - 600 \cos 30^\circ(6 \cos 30^\circ + 3 \cos 30^\circ) + 600 \sin 30^\circ(3 \sin 30^\circ) + B_y(6 \cos 30^\circ + 6 \cos 30^\circ) = 0$$

$$B_y = 927.4 \text{ lb}$$

$$\rightarrow \Sigma F_x = 0;$$

$$800 \sin 30^\circ - 600 \sin 30^\circ - A_x = 0$$

$$A_x = 100 \text{ lb}$$

$$+ \uparrow \Sigma F_y = 0;$$

$$A_y - 800 \cos 30^\circ - 700 - 600 \cos 30^\circ + 927.4 = 0$$

$$A_y = 985.1 \text{ lb}$$

$$\swarrow \Sigma F_x = 0;$$

$$N_D + 927.4 \sin 30^\circ = 0$$

$$N_D = -464 \text{ lb} \quad \text{Ans}$$

$$\nwarrow \Sigma F_y = 0;$$

$$V_D - 600 + 927.4 \cos 30^\circ = 0$$

$$V_D = -203 \text{ lb} \quad \text{Ans}$$

$$\zeta + \Sigma M_D = 0;$$

$$-M_D - 600(1) + 927.4(4 \cos 30^\circ) = 0$$

$$M_D = 2612 \text{ lb}\cdot\text{ft} = 2.61 \text{ kip}\cdot\text{ft} \quad \text{Ans}$$

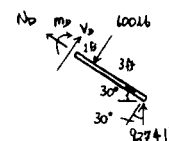
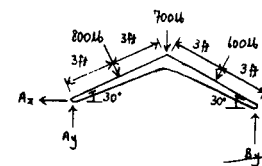

7-19. Determine the normal force, shear force, and moment at a section passing through point C. Take $P = 8 \text{ kN}$.

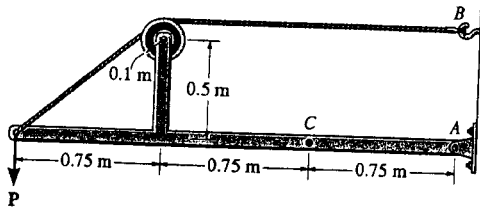

$$\zeta + \Sigma M_A = 0; \quad -T(0.6) + 8(2.25) = 0$$

$$T = 30 \text{ kN}$$

$$\rightarrow \Sigma F_x = 0; \quad A_x = 30 \text{ kN}$$

$$+ \uparrow \Sigma F_y = 0; \quad A_y = 8 \text{ kN}$$

$$\rightarrow \Sigma F_x = 0; \quad -N_C - 30 = 0$$

$$N_C = -30 \text{ kN}$$

Ans

$$+ \uparrow \Sigma F_y = 0; \quad V_C + 8 = 0$$

$$V_C = -8 \text{ kN}$$

Ans

$$\zeta + \Sigma M_C = 0; \quad -M_C + 8(0.75) = 0$$

$$M_C = 6 \text{ kN}\cdot\text{m}$$

Ans

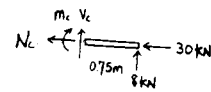
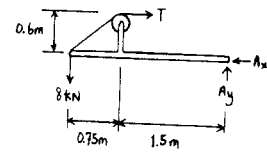

*7-20. The cable will fail when subjected to a tension of 2 kN. Determine the largest vertical load P the frame will support and calculate the internal normal force, shear force, and moment at a section passing through point C for this loading.

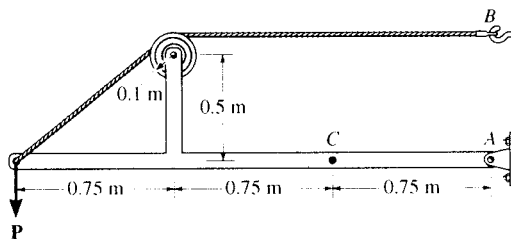

$$\zeta + \Sigma M_A = 0; \quad -2(0.6) + P(2.25) = 0$$

$$P = 0.533 \text{ kN}$$

Ans

$$\rightarrow \Sigma F_x = 0; \quad A_x = 2 \text{ kN}$$

$$+ \uparrow \Sigma F_y = 0; \quad A_y = 0.533 \text{ kN}$$

$$\rightarrow \Sigma F_x = 0; \quad -N_C - 2 = 0$$

$$N_C = -2 \text{ kN}$$

Ans

$$+ \uparrow \Sigma F_y = 0; \quad -V_C + 0.533 = 0$$

$$V_C = 0.533 \text{ kN}$$

Ans

$$\zeta + \Sigma M_C = 0; \quad -M_C + 0.533(0.75) = 0$$

$$M_C = 0.400 \text{ kN}\cdot\text{m}$$

Ans

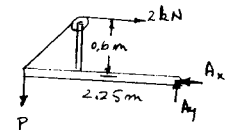

7-21. Determine the internal normal force, shear force, and bending moment in the beam at point B.

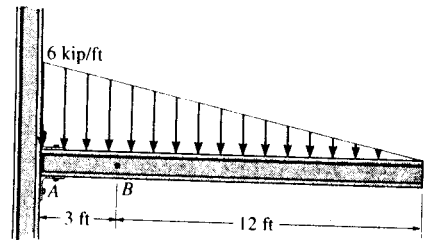

Free body Diagram : The support reactions at A need not be computed.

Internal Forces : Applying the equations of equilibrium to segment CB, we have

$$\begin{aligned} \rightarrow \Sigma F_x = 0; \quad N_B &= 0 && \text{Ans} \\ + \uparrow \Sigma F_y = 0; \quad V_B - 28.8 &= 0 \quad V_B = 28.8 \text{ kip} && \text{Ans} \\ \curvearrowright + \Sigma M_B = 0; \quad -28.8(4) - M_B &= 0 \\ M_B &= -115 \text{ kip} \cdot \text{ft} && \text{Ans} \end{aligned}$$

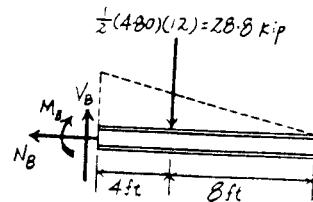

7-22. Determine the ratio of a/b for which the shear force will be zero at the midpoint C of the beam.

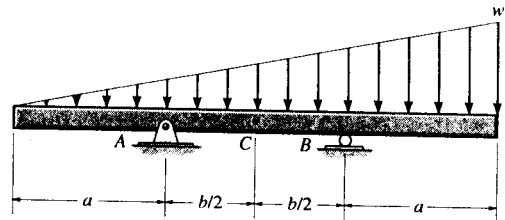

Support Reactions : From FBD (a).

$$\begin{aligned} \curvearrowright + \Sigma M_B = 0; \quad \frac{1}{2}(2a+b)w \left[\frac{1}{3}(b-a) \right] - A_y(b) &= 0 \\ A_y &= \frac{w}{6b}(2a+b)(b-a) \end{aligned}$$

Internal Forces : This problem requires $V_C = 0$. Summing forces vertically [FBD (b)], we have

$$+ \uparrow \Sigma F_y = 0; \quad \frac{w}{6b}(2a+b)(b-a) - \frac{1}{2}\left(a + \frac{b}{2}\right)\left(\frac{w}{2}\right) = 0$$

$$\frac{w}{6b}(2a+b)(b-a) = \frac{w}{8}(2a+b)$$

$$\frac{a}{b} = \frac{1}{4}$$

Ans

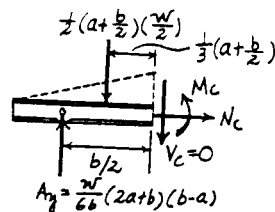
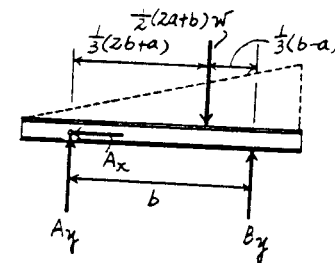

7-23. Determine the internal normal force, shear force, and bending moment at point C.

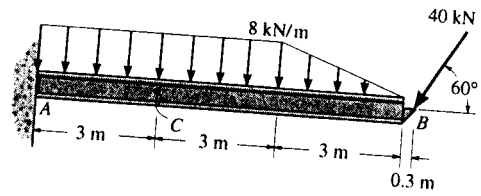

Free body Diagram : The support reactions at A need not be computed.

Internal Forces : Applying equations of equilibrium to segment BC, we have

$$\rightarrow \Sigma F_x = 0; \quad -40 \cos 60^\circ + N_C = 0 \quad N_C = 20.0 \text{ kN} \quad \text{Ans}$$

$$+\uparrow \Sigma F_y = 0; \quad V_C - 24.0 - 12.0 - 40 \sin 60^\circ = 0 \\ V_C = 70.6 \text{ kN} \quad \text{Ans}$$

$$\curvearrowleft + \Sigma M_C = 0; \quad -24.0(1.5) - 12.0(4) - 40 \sin 60^\circ (6.3) - M_C = 0 \\ M_C = -302 \text{ kN} \cdot \text{m} \quad \text{Ans}$$

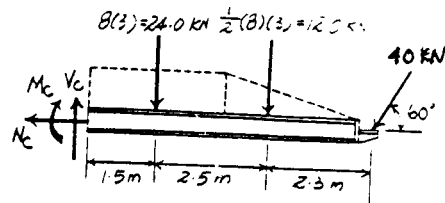

*7-24. The jack AB is used to straighten the bent beam DE using the arrangement shown. If the axial compressive force in the jack is 5000 lb, determine the internal moment developed at point C of the top beam. Neglect the weight of the beams.

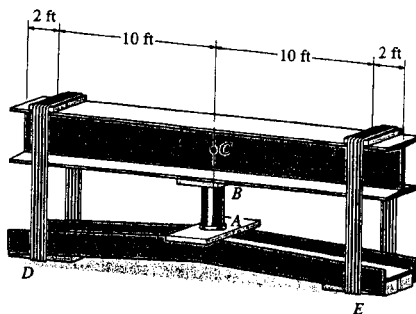

Segment :

$$\curvearrowleft + \Sigma M_C = 0; \quad M_C + 2500(10) = 0$$

$$M_C = -25.0 \text{ kip} \cdot \text{ft} \quad \text{Ans}$$

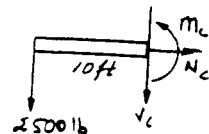
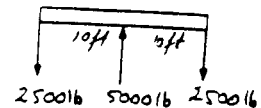

7-25. Solve Prob. 7-24 assuming that each beam has a uniform weight of 150 lb/ft.

Beam :

$$+\uparrow \Sigma F_y = 0; \quad 5000 - 3600 - 2R = 0$$

$$R = 700 \text{ lb}$$

Segment :

$$\curvearrowleft + \Sigma M_C = 0; \quad M_C + 700(10) + 1800(6) = 0$$

$$M_C = -17.8 \text{ kip} \cdot \text{ft} \quad \text{Ans}$$

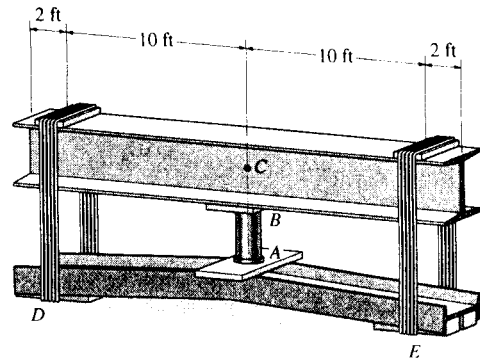
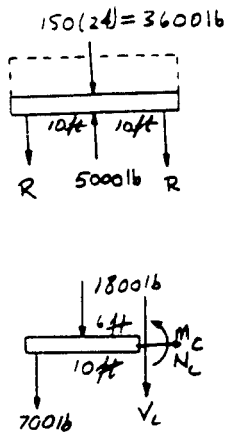

7-26. Determine the normal force, shear force, and moment in the beam at sections passing through points D and E. Point E is just to the right of the 3-kip load.

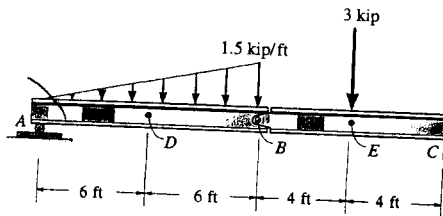

$$\curvearrowleft + \Sigma M_B = 0; \quad \frac{1}{2}(1.5)(12)(4) - A_y(12) = 0$$

$$A_y = 3 \text{ kip}$$

$$\rightarrow \Sigma F_x = 0; \quad B_x = 0$$

$$+\uparrow \Sigma F_y = 0; \quad B_y + 3 - \frac{1}{2}(1.5)(12) = 0$$

$$B_y = 6 \text{ kip}$$

$$\rightarrow \Sigma F_x = 0; \quad N_D = 0 \quad \text{Ans}$$

$$+\uparrow \Sigma F_y = 0; \quad 3 - \frac{1}{2}(0.75)(6) - V_D = 0$$

$$V_D = 0.75 \text{ kip} \quad \text{Ans}$$

$$\curvearrowleft + \Sigma M_D = 0; \quad M_D + \frac{1}{2}(0.75)(6)(2) - 3(6) = 0$$

$$M_D = 13.5 \text{ kip} \cdot \text{ft} \quad \text{Ans}$$

$$\rightarrow \Sigma F_x = 0; \quad N_E = 0 \quad \text{Ans}$$

$$+\uparrow \Sigma F_y = 0; \quad -V_E - 3 - 6 = 0$$

$$V_E = -9 \text{ kip} \quad \text{Ans}$$

$$\Sigma M_E = 0; \quad M_E + 6(4) = 0$$

$$M_E = -24.0 \text{ kip} \cdot \text{ft} \quad \text{Ans}$$

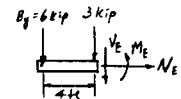
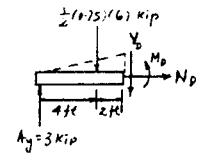
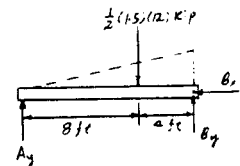

7-27. Determine the normal force, shear force, and moment at a section passing through point D of the two-member frame.

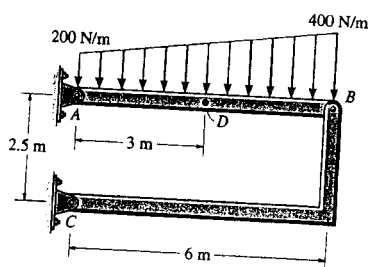

$$\begin{aligned} \zeta + \Sigma M_A = 0; & \quad -1200(3) - 600(4) + \frac{5}{13}F_{BC}(6) = 0 \\ & \quad F_{BC} = 2600 \text{ N} \\ \rightarrow \Sigma F_x = 0; & \quad A_x = \frac{12}{13}(2600) = 2400 \text{ N} \\ + \uparrow \Sigma F_y = 0; & \quad A_y - 1200 - 600 + \frac{5}{13}(2600) = 0 \\ & \quad A_y = 800 \text{ N} \\ \rightarrow \Sigma F_x = 0; & \quad N_D = 2400 \text{ N} = 2.40 \text{ kN} \\ + \uparrow \Sigma F_y = 0; & \quad 800 - 600 - 150 - V_D = 0 \\ & \quad V_D = 50 \text{ N} \\ \zeta + \Sigma M_D = 0; & \quad -800(3) + 600(1.5) + 150(1) + M_D = 0 \\ & \quad M_D = 1350 \text{ N}\cdot\text{m} = 1.35 \text{ kN}\cdot\text{m} \end{aligned}$$

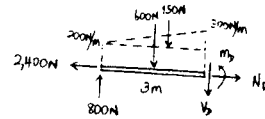
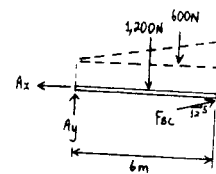

Ans
Ans
Ans
Ans

*7-28. Determine the normal force, shear force, and moment at sections passing through points E and F. Member BC is pinned at B and there is a smooth slot in it at C. The pin at C is fixed to member CD.

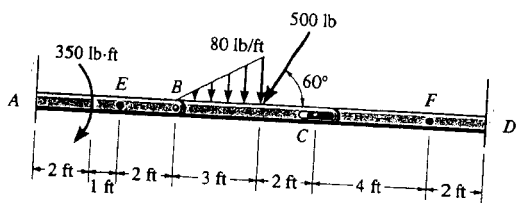

$$\begin{aligned} \zeta + \Sigma M_B = 0; & \quad -120(2) - 500 \sin 60^\circ(3) + C_y(5) = 0 \\ & \quad C_y = 307.8 \text{ lb} \\ \rightarrow \Sigma F_x = 0; & \quad B_x - 500 \cos 60^\circ = 0 \\ & \quad B_x = 250 \text{ lb} \\ + \uparrow \Sigma F_y = 0; & \quad B_y - 120 - 500 \sin 60^\circ + 307.8 = 0 \\ & \quad B_y = 245.2 \text{ lb} \\ \rightarrow \Sigma F_x = 0; & \quad -N_E - 250 = 0 \\ & \quad N_E = -250 \text{ lb} \\ + \uparrow \Sigma F_y = 0; & \quad V_E = 245 \text{ lb} \\ \zeta + \Sigma M_E = 0; & \quad -M_E - 245.2(2) = 0 \\ & \quad M_E = -490 \text{ lb}\cdot\text{ft} \\ \rightarrow \Sigma F_x = 0; & \quad N_F = 0 \\ + \uparrow \Sigma F_y = 0; & \quad -307.8 - V_F = 0 \\ & \quad V_F = -308 \text{ lb} \\ \zeta + \Sigma M_F = 0; & \quad 307.8(4) + M_F = 0 \\ & \quad M_F = -1231 \text{ lb}\cdot\text{ft} = -1.23 \text{ kip}\cdot\text{ft} \end{aligned}$$

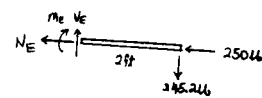
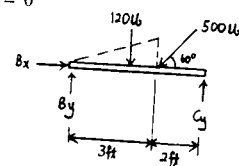

Ans
Ans
Ans
Ans
Ans

7-29. Determine the internal normal force, shear force, and the moment at points C and D.

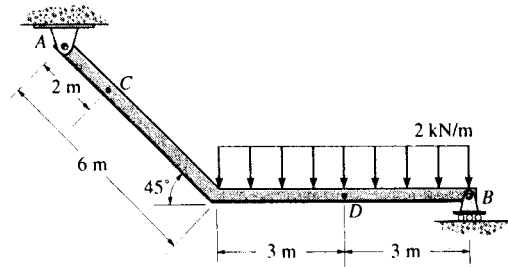

Support Reactions : FBD (a).

$$\begin{aligned} \curvearrowright + \Sigma M_A = 0; & \quad B_y (6 + 6 \cos 45^\circ) - 12.0(3 + 6 \cos 45^\circ) = 0 \\ & \quad B_y = 8.485 \text{ kN} \\ + \uparrow \Sigma F_y = 0; & \quad A_y + 8.485 - 12.0 = 0 \quad A_y = 3.515 \text{ kN} \\ \rightarrow \Sigma F_x = 0 & \quad A_x = 0 \end{aligned}$$

Internal Forces : Applying the equations of equilibrium to segment AC [FBD (b)], we have

$$\begin{aligned} \nearrow + \Sigma F_x = 0; & \quad 3.515 \cos 45^\circ - V_C = 0 \quad V_C = 2.49 \text{ kN} \quad \text{Ans} \\ \nwarrow + \Sigma F_y = 0; & \quad 3.515 \sin 45^\circ - N_C = 0 \quad N_C = 2.49 \text{ kN} \quad \text{Ans} \\ \curvearrowright + \Sigma M_C = 0; & \quad M_C - 3.515 \cos 45^\circ (2) = 0 \\ & \quad M_C = 4.97 \text{ kN} \cdot \text{m} \quad \text{Ans} \end{aligned}$$

Applying the equations of equilibrium to segment BD [FBD (c)], we have

$$\begin{aligned} \rightarrow \Sigma F_x = 0; & \quad N_D = 0 \quad \text{Ans} \\ + \uparrow \Sigma F_y = 0; & \quad V_D + 8.485 - 6.00 = 0 \quad V_D = -2.49 \text{ kN} \quad \text{Ans} \\ \curvearrowright + \Sigma M_D = 0; & \quad 8.485(3) - 6(1.5) - M_D = 0 \\ & \quad M_D = 16.5 \text{ kN} \cdot \text{m} \quad \text{Ans} \end{aligned}$$

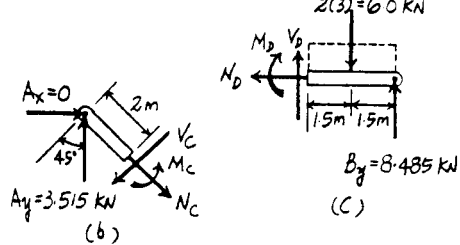
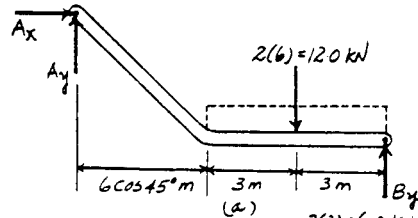

7-30. Determine the normal force, shear force, and moment acting at sections passing through points *B* and *C* on the curved rod.

$$\nearrow + \Sigma F_x = 0; \quad 400 \sin 30^\circ - 300 \cos 30^\circ + N_B = 0$$

$$N_B = 59.8 \text{ lb} \quad \text{Ans}$$

$$+ \searrow \Sigma F_y = 0; \quad V_B + 400 \cos 30^\circ + 300 \sin 30^\circ = 0$$

$$V_B = -496 \text{ lb} \quad \text{Ans}$$

$$\curvearrow + \Sigma M_B = 0; \quad M_B + 400(2 \sin 30^\circ)$$

$$+ 300(2 - 2 \cos 30^\circ) = 0$$

$$M_B = -480 \text{ lb}\cdot\text{ft} \quad \text{Ans}$$

Also,

$$\curvearrow + \Sigma M_O = 0; \quad -59.81(2) + 300(2) + M_B = 0$$

$$M_B = -480 \text{ lb}\cdot\text{ft} \quad \text{Ans}$$

$$\rightarrow \Sigma F_x = 0; \quad A_x = 400 \text{ lb}$$

$$+ \uparrow \Sigma F_y = 0; \quad A_y = 300 \text{ lb}$$

$$\curvearrow + \Sigma M_A = 0; \quad M_A - 300(4) = 0$$

$$M_A = 1200 \text{ lb}\cdot\text{ft}$$

$$+ \searrow \Sigma F_x = 0; \quad N_C + 400 \sin 45^\circ + 300 \cos 45^\circ = 0$$

$$N_C = -495 \text{ lb} \quad \text{Ans}$$

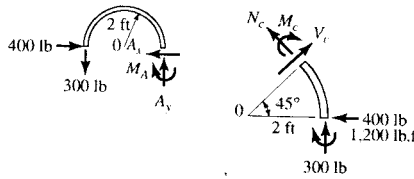
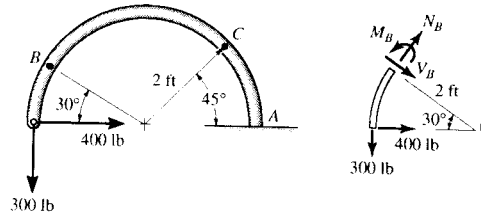

$$\nearrow + \Sigma F_y = 0; \quad V_C - 400 \cos 45^\circ + 300 \sin 45^\circ = 0$$

$$V_C = 70.7 \text{ lb} \quad \text{Ans}$$

$$\curvearrow + \Sigma M_C = 0; \quad -M_C - 1200 - 400(2 \sin 45^\circ)$$

$$+ 300(2 - 2 \cos 45^\circ) = 0$$

$$M_C = -1590 \text{ lb}\cdot\text{ft} = -1.59 \text{ kip}\cdot\text{ft} \quad \text{Ans}$$

Also,

$$\curvearrow + \Sigma M_O = 0; \quad 495.0(2) + 300(2) + M_C = 0$$

$$M_C = -1590 \text{ lb}\cdot\text{ft} = -1.59 \text{ kip}\cdot\text{ft} \quad \text{Ans}$$

7-31. The cantilevered rack is used to support each end of a smooth pipe that has a total weight of 300 lb. Determine the normal force, shear force, and moment that act in the arm at its fixed support *A* along a vertical section.

Pipe:

$$+ \uparrow \Sigma F_x = 0; \quad N_B \cos 30^\circ - 150 = 0$$

$$N_B = 173.205 \text{ lb}$$

Rack:

$$\rightarrow \Sigma F_x = 0; \quad -N_A + 173.205 \sin 30^\circ = 0$$

$$N_A = 86.6 \text{ lb} \quad \text{Ans}$$

$$+ \uparrow \Sigma F_y = 0; \quad V_A - 173.205 \cos 30^\circ = 0$$

$$V_A = 150 \text{ lb} \quad \text{Ans}$$

$$\curvearrow + \Sigma M_A = 0; \quad M_A - 173.205(10.3923) = 0$$

$$M_A = 1800 \text{ lb}\cdot\text{in.} \quad \text{Ans}$$

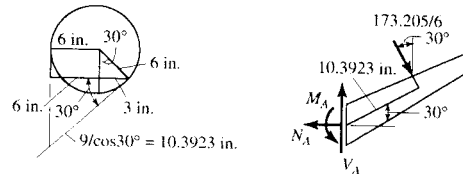
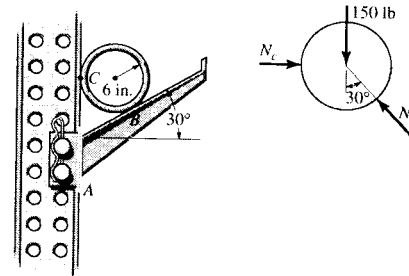

*7-32. Determine the normal force, shear force, and moment at a section passing through point D of the two-member frame.

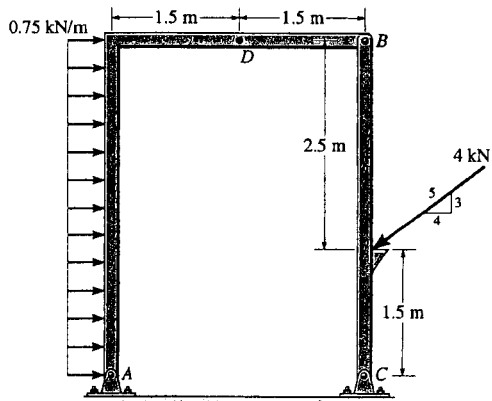

$$\begin{aligned} \curvearrowleft + \Sigma M_A = 0; & \quad -3(2) + B_y(3) + B_x(4) = 0 \\ \curvearrowleft + \Sigma M_C = 0; & \quad -B_x(4) + \frac{4}{5}(4)(1.5) = 0 \\ & \quad B_x = 1.2 \text{ kN} \\ & \quad B_y = 0.4 \text{ kN} \\ \rightarrow \Sigma F_x = 0; & \quad -N_D - 1.2 = 0 \\ & \quad N_D = -1.2 \text{ kN} \\ + \uparrow \Sigma F_y = 0; & \quad V_D + 0.4 = 0 \\ & \quad V_D = -0.4 \text{ kN} \\ \curvearrowleft + \Sigma M_D = 0; & \quad -M_D + 0.4(1.5) = 0 \\ & \quad M_D = 0.6 \text{ kN}\cdot\text{m} \end{aligned}$$

Ans

Ans

Ans

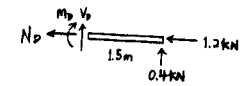
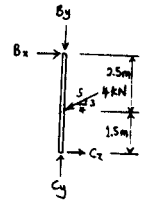
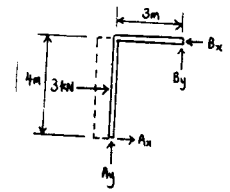

7-33. Determine the internal normal force, shear force, and bending moment in the beam at points D and E . Point E is just to the right of the 4-kip load. Assume A is a roller support, the splice at B is a pin, and C is a fixed support.

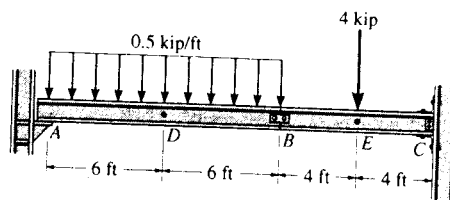

Support Reactions : Support reactions at C need not be computed for this case. From FBD (a),

$$\begin{aligned} \left(+\Sigma M_B = 0; \quad 6.00(6) - A_y(12) = 0 \quad A_y = 3.00 \text{ kN} \right. \\ \left. +\uparrow \Sigma F_y = 0; \quad B_y + 3.00 - 6.00 = 0 \quad B_y = 3.00 \text{ kN} \right. \\ \left. \rightarrow \Sigma F_x = 0 \quad B_x = 0 \right. \end{aligned}$$

Internal Forces : Applying the equations of equilibrium to segment AD [FBD (b)], we have

$$\begin{aligned} \rightarrow \Sigma F_x = 0; \quad N_D = 0 \quad \text{Ans} \\ +\uparrow \Sigma F_y = 0; \quad 3.00 - 3.00 - V_D = 0 \quad V_D = 0 \quad \text{Ans} \\ \left(+\Sigma M_D = 0; \quad M_D - 3.00(3) = 0 \quad M_D = 9.00 \text{ kN} \cdot \text{m} \quad \text{Ans} \right. \end{aligned}$$

Applying the equations of equilibrium to segment BE [FBD (c)], we have

$$\begin{aligned} \rightarrow \Sigma F_x = 0; \quad N_E = 0 \quad \text{Ans} \\ +\uparrow \Sigma F_y = 0; \quad -3.00 - 4 - V_E = 0 \quad V_E = -7.00 \text{ kN} \quad \text{Ans} \\ \left(+\Sigma M_E = 0; \quad M_E + 3.00(4) = 0 \quad M_E = -12.0 \text{ kN} \cdot \text{m} \quad \text{Ans} \right. \end{aligned}$$

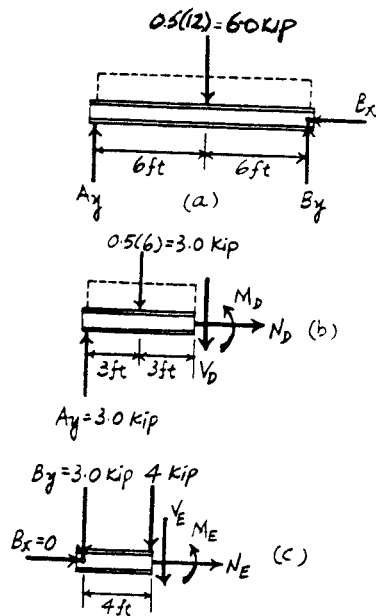

7-34. Determine the internal normal force, shear force, and bending moment at points *E* and *F* of the frame.

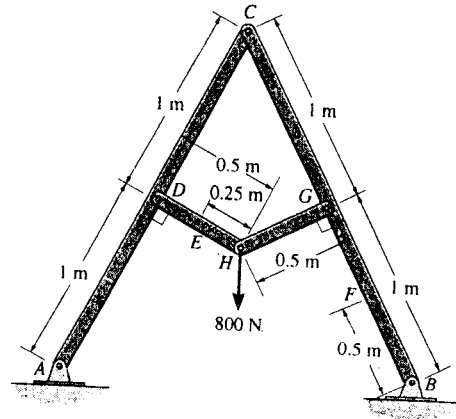

Support Reactions : Members *HD* and *HG* are two force members. Using method of joint [FBD (a)], we have

$$\begin{aligned} \rightarrow \Sigma F_x = 0 \quad & F_{HG} \cos 26.57^\circ - F_{HD} \cos 26.57^\circ = 0 \\ & F_{HD} = F_{HG} = F \\ + \uparrow \Sigma F_y = 0; \quad & 2F \sin 26.57^\circ - 800 = 0 \\ & F_{HD} = F_{HG} = F = 894.43 \text{ N} \end{aligned}$$

From FBD (b),

$$\left(+ \Sigma M_A = 0; \quad C_x (2 \cos 26.57^\circ) + C_y (2 \sin 26.57^\circ) - 894.43 (1) = 0 \quad [1] \right.$$

From FBD (c),

$$\left(+ \Sigma M_B = 0; \quad 894.43 (1) - C_x (2 \cos 26.57^\circ) + C_y (2 \sin 26.57^\circ) = 0 \quad [2] \right.$$

Solving Eqs. [1] and [2] yields,

$$C_y = 0 \quad C_x = 500 \text{ N}$$

Internal Forces : Applying the equations of equilibrium to segment *DE* [FBD (d)], we have

$$+ \Sigma F_x = 0; \quad V_E = 0 \quad \text{Ans}$$

$$+ \Sigma F_y = 0; \quad 894.43 - N_E = 0 \quad N_E = 894 \text{ N} \quad \text{Ans}$$

$$\left(+ \Sigma M_E = 0; \quad M_E = 0 \quad \text{Ans} \right.$$

Applying the equations of equilibrium to segment *CF* [FBD (e)], we have

$$+ \Sigma F_x = 0; \quad V_F + 500 \cos 26.57^\circ - 894.43 = 0 \quad \text{Ans}$$

$$V_F = 447 \text{ N}$$

$$\downarrow + \Sigma F_y = 0; \quad N_F - 500 \sin 26.57^\circ = 0 \quad N_F = 224 \text{ N} \quad \text{Ans}$$

$$\left(+ \Sigma M_F = 0; \quad M_F + 894.43 (0.5) - 500 \cos 26.57^\circ (1.5) = 0 \quad \text{Ans} \right.$$

$$M_F = 224 \text{ N} \cdot \text{m}$$

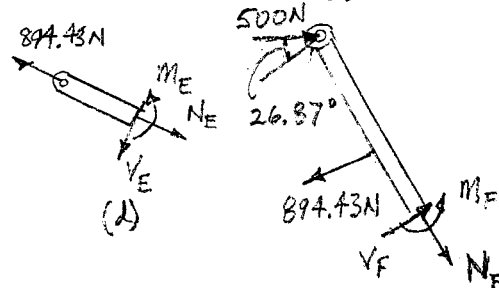
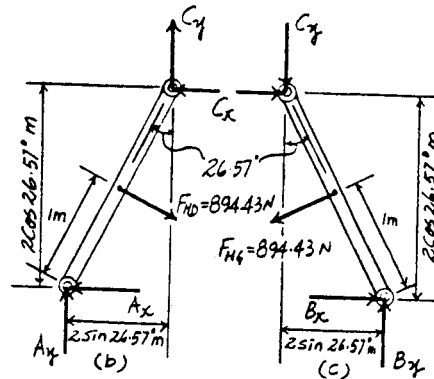
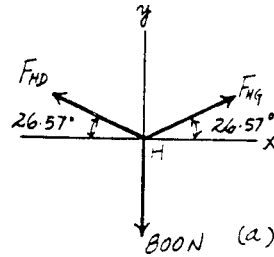

7-35. Draw the shear and moment diagrams for the beam (a) in terms of the parameters shown; (b) set $P = 800$ lb, $a = 5$ ft, $L = 12$ ft.

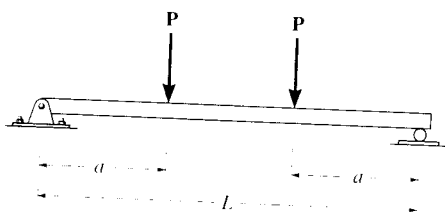

(a) For $0 \leq x < a$

$+\uparrow \Sigma F_y = 0; \quad V = P \quad \text{Ans}$

$(+\Sigma M = 0; \quad M = Px \quad \text{Ans}$

For $a < x < L - a$

$+\uparrow \Sigma F_y = 0; \quad V = 0 \quad \text{Ans}$

$(+\Sigma M = 0; \quad -Px + P(x-a) + M = 0$

$M = Pa \quad \text{Ans}$

For $L - a < x \leq L$

$+\uparrow \Sigma F_y = 0; \quad V = -P \quad \text{Ans}$

$(+\Sigma M = 0; \quad -M + P(L-x) = 0$

$M = P(L-x) \quad \text{Ans}$

(b) Set $P = 800$ lb, $a = 5$ ft, $L = 12$ ft

For $0 \leq x \leq 5$ ft

$+\uparrow \Sigma F_y = 0; \quad V = 800 \text{ lb} \quad \text{Ans}$

$(+\Sigma M = 0; \quad M = 800x \text{ lb}\cdot\text{ft} \quad \text{Ans}$

For $5 \text{ ft} < x < 7 \text{ ft}$

$+\uparrow \Sigma F_y = 0; \quad V = 0 \quad \text{Ans}$

$(+\Sigma M = 0; \quad -800x + 800(x-5) + M = 0$

$M = 4000 \text{ lb}\cdot\text{ft} \quad \text{Ans}$

For $7 \text{ ft} < x \leq 12 \text{ ft}$

$+\uparrow \Sigma F_y = 0; \quad V = -800 \text{ lb} \quad \text{Ans}$

$(+\Sigma M = 0; \quad -M + 800(12-x) = 0$

$M = (9600 - 800x) \text{ lb}\cdot\text{ft} \quad \text{Ans}$

7-35. Determine the distance a as a fraction of the beam's length L for locating the roller support so that the moment in the beam at B is zero.

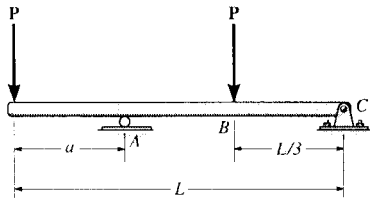

$$\curvearrowleft +\Sigma M_A = 0; \quad -P\left(\frac{2L}{3} - a\right) + C_y(L - a) + Pa = 0$$

$$C_y = \frac{2P\left(\frac{L}{3} - a\right)}{L - a}$$

$$\curvearrowleft +\Sigma M = 0; \quad M = \frac{2P\left(\frac{L}{3} - a\right)}{L - a} \left(\frac{L}{3}\right) = 0$$

$$2PL\left(\frac{L}{3} - a\right) = 0$$

$$a = \frac{L}{3}$$

Ans

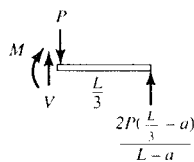
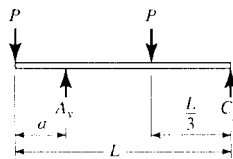

*7-36. The semicircular arch is subjected to a uniform distributed load along its axis of w_0 per unit length. Determine the internal normal force, shear force, and moment in the arch at $\theta = 45^\circ$.

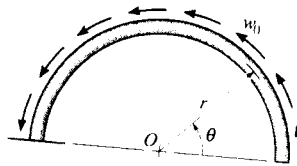

Resultants of distributed load:

$$F_{Rx} = \int_0^\theta w_0(r d\theta) \sin \theta = r w_0 (-\cos \theta) \Big|_0^\theta = r w_0 (1 - \cos \theta)$$

$$F_{Ry} = \int_0^\theta w_0(r d\theta) \cos \theta = r w_0 (\sin \theta) \Big|_0^\theta = r w_0 (\sin \theta)$$

$$M_{R_0} = \int_0^\theta w_0(r d\theta) r = r^2 w_0 \theta$$

At $\theta = 45^\circ$

$$\uparrow \Sigma F_x = 0: -V + F_{Rx} \cos \theta - F_{Ry} \sin \theta = 0$$

$$V = 0.2929 r w_0 \cos 45^\circ - 0.707 r w_0 \sin 45^\circ$$

$$V = -0.293 r w_0 \quad \text{Ans}$$

$$\rightarrow \Sigma F_y = 0: N + F_{Ry} \cos \theta + F_{Rx} \sin \theta = 0$$

$$N = -0.707 r w_0 \sin 45^\circ - 0.2929 r w_0 \cos 45^\circ$$

$$N = -0.707 r w_0 \quad \text{Ans}$$

$$\curvearrowright \Sigma M_0 = 0: -M + r^2 w_0 \left(\frac{\pi}{4}\right) + (-0.707 r w_0)(r) = 0$$

$$M = -0.0783 r^2 w_0 \quad \text{Ans}$$

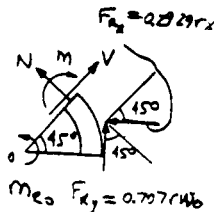
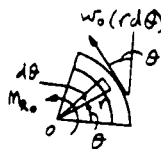

7-37. Solve Prob. 7-36 for $\theta = 120^\circ$.

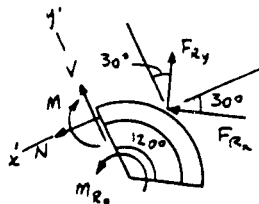
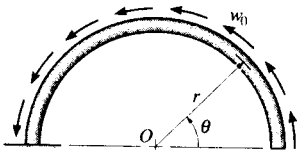

Resultants of distributed load:

$$F_{Rx} = \int_0^\theta w_0(r d\theta) \sin \theta = r w_0 (-\cos \theta) \Big|_0^\theta = r w_0 (1 - \cos \theta)$$

$$F_{Ry} = \int_0^\theta w_0(r d\theta) \cos \theta = r w_0 (\sin \theta) \Big|_0^\theta = r w_0 (\sin \theta)$$

$$M_{R_0} = \int_0^\theta w_0(r d\theta) r = r^2 w_0 \theta$$

At $\theta = 120^\circ$,

$$F_{Rx} = r w_0 (1 - \cos 120^\circ) = 1.5 r w_0$$

$$F_{Ry} = r w_0 \sin 120^\circ = 0.86603 r w_0$$

$$\rightarrow \Sigma F_x = 0: N + 1.5 r w_0 \cos 30^\circ - 0.86603 r w_0 \sin 30^\circ = 0$$

$$N = -0.866 r w_0 \quad \text{Ans}$$

$$\uparrow \Sigma F_y = 0: V + 1.5 r w_0 \sin 30^\circ + 0.86603 r w_0 \cos 30^\circ = 0$$

$$V = -1.5 r w_0 \quad \text{Ans}$$

$$\curvearrowright \Sigma M_0 = 0: -M + r^2 w_0 \left(\frac{\pi}{180^\circ}\right) + (-0.866 r w_0) r = 0$$

$$M = 1.23 r^2 w_0 \quad \text{Ans}$$

7-38. Determine the x , y , z components of internal loading at a section passing through point C in the pipe assembly. Neglect the weight of the pipe. Take $F_1 = \{350\mathbf{j} - 400\mathbf{k}\}$ lb and $F_2 = \{150\mathbf{i} - 300\mathbf{k}\}$ lb.

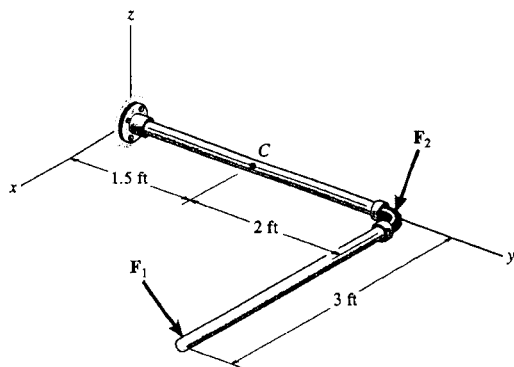

$$\Sigma F_R = 0;$$

$$F_C + F_1 + F_2 = 0$$

$$F_C = \{-150\mathbf{i} - 350\mathbf{j} + 700\mathbf{k}\} \text{ lb}$$

$$C_x = -150 \text{ lb} \quad \text{Ans}$$

$$C_y = -350 \text{ lb} \quad \text{Ans}$$

$$C_z = 700 \text{ lb} \quad \text{Ans}$$

$$\Sigma M_R = 0; \quad M_C + r_{C1} \times F_1 + r_{C2} \times F_2 = 0$$

$$M_C + \begin{vmatrix} \mathbf{i} & \mathbf{j} & \mathbf{k} \\ 3 & 2 & 0 \\ 0 & 350 & -400 \end{vmatrix} + \begin{vmatrix} \mathbf{i} & \mathbf{j} & \mathbf{k} \\ 0 & 2 & 0 \\ 150 & 0 & -300 \end{vmatrix} = 0$$

$$M_C = \{1400\mathbf{i} - 1200\mathbf{j} - 750\mathbf{k}\} \text{ lb}\cdot\text{ft}$$

$$M_{Cx} = 1.40 \text{ kip}\cdot\text{ft} \quad \text{Ans}$$

$$M_{Cy} = -1.20 \text{ kip}\cdot\text{ft} \quad \text{Ans}$$

$$M_{Cz} = -750 \text{ lb}\cdot\text{ft} \quad \text{Ans}$$

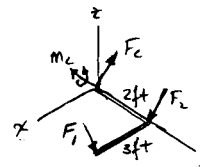

7-39. Determine the x , y , z components of internal loading at a section passing through point C in the pipe assembly. Neglect the weight of the pipe. Take $F_1 = \{-80\mathbf{i} + 200\mathbf{j} - 300\mathbf{k}\}$ lb and $F_2 = \{250\mathbf{i} - 150\mathbf{j} - 200\mathbf{k}\}$ lb.

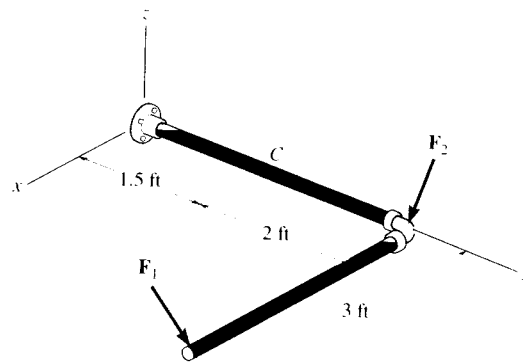

$$\Sigma F_R = 0; \quad F_C + F_1 + F_2 = 0$$

$$F_C = \{-170\mathbf{i} - 50\mathbf{j} + 500\mathbf{k}\} \text{ lb}$$

$$C_x = -170 \text{ lb} \quad \text{Ans}$$

$$C_y = -50 \text{ lb} \quad \text{Ans}$$

$$C_z = 500 \text{ lb} \quad \text{Ans}$$

$$\Sigma M_R = 0; \quad M_C + r_{C1} \times F_1 + r_{C2} \times F_2 = 0$$

$$M_C + \begin{vmatrix} \mathbf{i} & \mathbf{j} & \mathbf{k} \\ 3 & 2 & 0 \\ -80 & 200 & -300 \end{vmatrix} + \begin{vmatrix} \mathbf{i} & \mathbf{j} & \mathbf{k} \\ 0 & 2 & 0 \\ 250 & -150 & -200 \end{vmatrix} = 0$$

$$M_C = \{1000\mathbf{i} - 900\mathbf{j} - 260\mathbf{k}\} \text{ lb}\cdot\text{ft}$$

$$M_{Cx} = 1 \text{ kip}\cdot\text{ft} \quad \text{Ans}$$

$$M_{Cy} = -900 \text{ lb}\cdot\text{ft} \quad \text{Ans}$$

$$M_{Cz} = -260 \text{ lb}\cdot\text{ft} \quad \text{Ans}$$

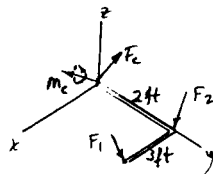

*7-40. Determine the x , y , z components of force and moment at point C in the pipe assembly. Neglect the weight of the pipe. The load acting at $(0, 3.5 \text{ ft}, 3 \text{ ft})$ is $\mathbf{F}_1 = \{-24\mathbf{i} - 10\mathbf{k}\} \text{ lb}$ and $\mathbf{M} = \{-30\mathbf{k}\} \text{ lb} \cdot \text{ft}$ and at point $(0, 3.5 \text{ ft}, 0)$ $\mathbf{F}_2 = \{-80\mathbf{i}\} \text{ lb}$.

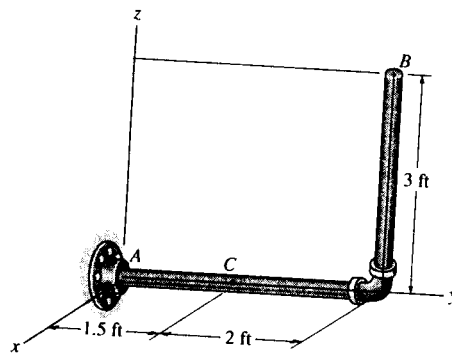

Free body Diagram : The support reactions need not be computed.

Internal Forces : Applying the equations of equilibrium to segment BC , we have

$$\begin{aligned} \Sigma F_x = 0; & \quad (V_C)_x - 24 - 80 = 0 & \quad (V_C)_x = 104 \text{ lb} & \quad \text{Ans} \\ \Sigma F_y = 0; & \quad N_C = 0 & & \quad \text{Ans} \\ \Sigma F_z = 0; & \quad (V_C)_z - 10 = 0 & \quad (V_C)_z = 10.0 \text{ lb} & \quad \text{Ans} \\ \Sigma M_x = 0; & \quad (M_C)_x - 10(2) = 0 & \quad (M_C)_x = 20.0 \text{ lb} \cdot \text{ft} & \quad \text{Ans} \\ \Sigma M_y = 0; & \quad (M_C)_y - 24(3) = 0 & \quad (M_C)_y = 72.0 \text{ lb} \cdot \text{ft} & \quad \text{Ans} \\ \Sigma M_z = 0; & \quad (M_C)_z + 24(2) + 80(2) - 30 = 0 & & \\ & \quad (M_C)_z = -178 \text{ lb} \cdot \text{ft} & & \quad \text{Ans} \end{aligned}$$

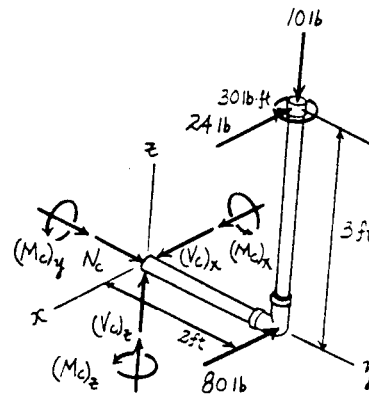

7-41. Determine the x , y , z components of force and moment at point C in the pipe assembly. Neglect the weight of the pipe. Take $\mathbf{F}_1 = \{350\mathbf{i} - 400\mathbf{j}\}$ lb and $\mathbf{F}_2 = \{-300\mathbf{j} + 150\mathbf{k}\}$ lb.

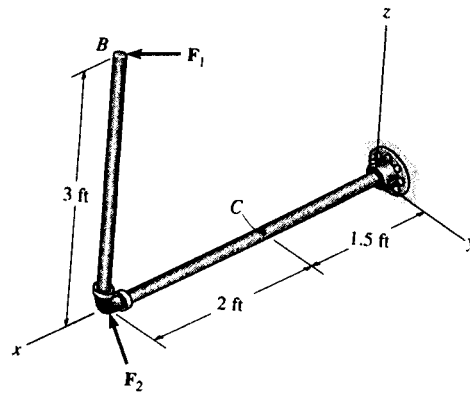

Free body Diagram : The support reactions need not be computed.

Internal Forces : Applying the equations of equilibrium to segment BC , we have

$$\Sigma F_x = 0; \quad N_C + 350 = 0 \quad N_C = -350 \text{ lb} \quad \text{Ans}$$

$$\Sigma F_y = 0; \quad (V_C)_y - 400 - 300 = 0 \quad (V_C)_y = 700 \text{ lb} \quad \text{Ans}$$

$$\Sigma F_z = 0; \quad (V_C)_z + 150 = 0 \quad (V_C)_z = -150 \text{ lb} \quad \text{Ans}$$

$$\Sigma M_x = 0; \quad (M_C)_x + 400(3) = 0 \\ (M_C)_x = -1200 \text{ lb} \cdot \text{ft} = -1.20 \text{ kip} \cdot \text{ft} \quad \text{Ans}$$

$$\Sigma M_y = 0; \quad (M_C)_y + 350(3) - 150(2) = 0 \\ (M_C)_y = -750 \text{ lb} \cdot \text{ft} \quad \text{Ans}$$

$$\Sigma M_z = 0; \quad (M_C)_z - 300(2) - 400(2) = 0 \\ (M_C)_z = 1400 \text{ lb} \cdot \text{ft} = 1.40 \text{ kip} \cdot \text{ft} \quad \text{Ans}$$

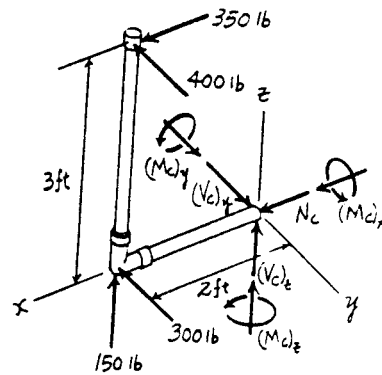

7-42. Draw the shear and moment diagrams for the beam (a) in terms of the parameters shown; (b) set $P = 600$ lb, $a = 5$ ft, $b = 7$ ft.

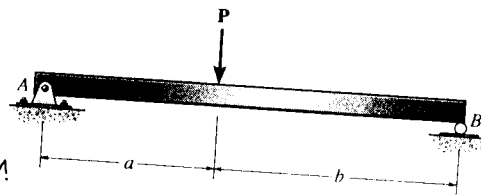

(a) For $0 \leq x < a$

$$+\uparrow \Sigma F_y = 0; \quad \frac{Pb}{a+b} - V = 0$$

$$V = \frac{Pb}{a+b} \quad \text{Ans}$$

$$(+\Sigma M = 0; \quad M - \frac{Pb}{a+b}x = 0$$

$$M = \frac{Pb}{a+b}x \quad \text{Ans}$$

For $a < x \leq (a+b)$

$$+\uparrow \Sigma F_y = 0; \quad \frac{Pb}{a+b} - P - V = 0$$

$$V = -\frac{Pa}{a+b} \quad \text{Ans}$$

$$(+\Sigma M = 0; \quad -\frac{Pb}{a+b}x + P(x-a) + M = 0$$

$$M = Pa - \frac{Pa}{a+b}x \quad \text{Ans}$$

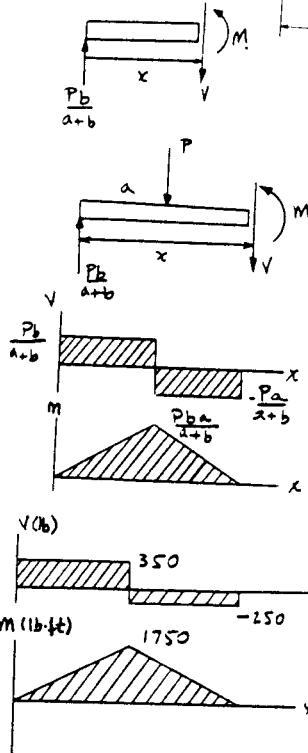

(b) For $P = 600$ lb, $a = 5$ ft, $b = 7$ ft

7-43. Draw the shear and moment diagrams for the cantilevered beam.

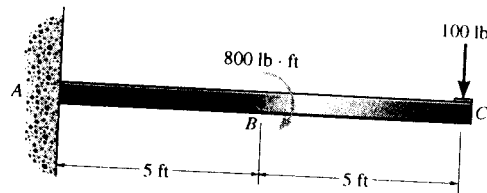
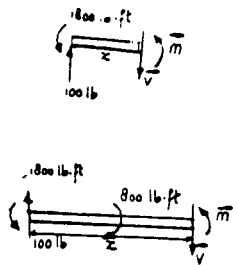

For $0 \leq x < 5$ ft:

$$+\uparrow \Sigma F_y = 0; \quad 100 - V = 0; \quad V = 100 \quad \text{Ans}$$

$$(+\Sigma M = 0; \quad M - 100x + 1800 = 0; \quad M = 100x - 1800 \quad \text{Ans}$$

For $5 < x \leq 10$ ft:

$$+\uparrow \Sigma F_y = 0; \quad 100 - V = 0; \quad V = 100 \quad \text{Ans}$$

$$(+\Sigma M = 0; \quad M - 100x + 1000 = 0; \quad M = 100x - 1000 \quad \text{Ans}$$

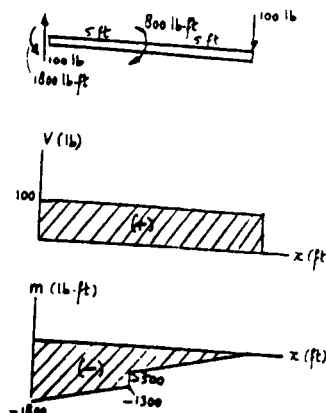

7-44. The suspender bar supports the 600-lb engine.
 Draw the shear and moment diagrams for the bar.

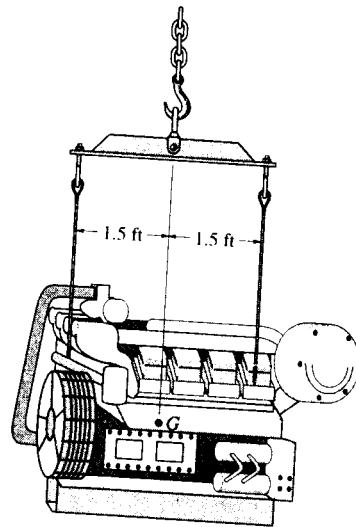

For $0 \leq x < 1.5$ ft:

$$+\uparrow \Sigma F_y = 0: -300 - V = 0$$

$$V = -300 \quad \text{Ans}$$

$$\curvearrowright + \Sigma M = 0: M + 300x = 0$$

$$M = -300x \quad \text{Ans}$$

For $1.5 \text{ ft} < x \leq 3$ ft:

$$+\uparrow \Sigma F_y = 0: 600 - 300 - V = 0$$

$$V = 300 \quad \text{Ans}$$

$$\curvearrowright + \Sigma M = 0: M + 300x - 600(x - 1.5) = 0$$

$$M = 300x - 900 \quad \text{Ans}$$

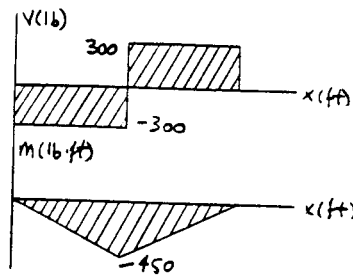
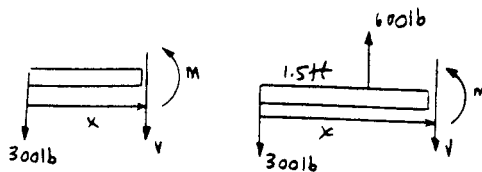

7-45. Draw the shear and moment diagrams for the beam (a) in terms of the parameters shown; (b) set $M_0 = 500 \text{ N}\cdot\text{m}$, $L = 8 \text{ m}$.

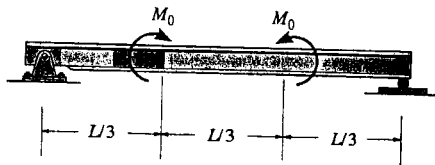

(a) For $0 \leq x \leq \frac{L}{3}$

$+\uparrow \Sigma F_y = 0; \quad V = 0$ Ans

$\zeta + \Sigma M = 0; \quad M = 0$ Ans

For $\frac{L}{3} < x < \frac{2L}{3}$

$+\uparrow \Sigma F_y = 0; \quad V = 0$ Ans

$\zeta + \Sigma M = 0; \quad M = M_0$ Ans

For $\frac{2L}{3} < x \leq L$

$+\uparrow \Sigma F_y = 0; \quad V = 0$ Ans

$\zeta + \Sigma M = 0; \quad M = 0$ Ans

(b) Set $M_0 = 500 \text{ N}\cdot\text{m}$, $L = 8 \text{ m}$

For $0 \leq x < \frac{8}{3} \text{ m}$

$+\uparrow \Sigma F_y = 0; \quad V = 0$ Ans

$\zeta + \Sigma M = 0; \quad M = 0$ Ans

For $\frac{8}{3} \text{ m} < x < \frac{16}{3} \text{ m}$

$+\uparrow \Sigma F_y = 0; \quad V = 0$ Ans

$\zeta + \Sigma M = 0; \quad M = 500 \text{ N}\cdot\text{m}$ Ans

For $\frac{16}{3} \text{ m} < x \leq 8 \text{ m}$

$+\uparrow \Sigma F_y = 0; \quad V = 0$ Ans

$\zeta + \Sigma M = 0; \quad M = 0$ Ans

7-46. If $L = 9 \text{ m}$, the beam will fail when the maximum shear force is $V_{\max} = 5 \text{ kN}$ or the maximum bending moment is $M_{\max} = 2 \text{ kN}\cdot\text{m}$. Determine the magnitude M_0 of the largest couple moments it will support.

See solution to Prob. 7-45

$M_{\max} = M_0 = 2 \text{ kN}\cdot\text{m}$ Ans

7-47. The shaft is supported by a thrust bearing at A and a journal bearing at B . If $L = 10$ ft the shaft will fail when the maximum moment is $M_{\max} = 5$ kip-ft. Determine the largest uniform distributed load w the shaft will support.

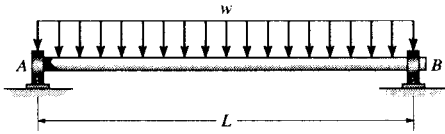

For $0 \leq x \leq L$

$$+\uparrow \Sigma F_y = 0; \quad \frac{wL}{2} - wx - V = 0$$

$$V = -wx + \frac{wL}{2}$$

$$V = \frac{w}{2}(L - 2x)$$

$$\curvearrowleft + \Sigma M = 0; \quad -\frac{wL}{2}x + wx\left(\frac{x}{2}\right) + M = 0$$

$$M = \frac{wL}{2}x - \frac{wx^2}{2}$$

$$M = \frac{w}{2}(Lx - x^2)$$

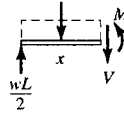

From the moment diagram

$$M_{\max} = \frac{wL^2}{8}$$

$$5000 = \frac{w(10)^2}{8}$$

$$w = 400 \text{ lb/ft} \quad \text{Ans}$$

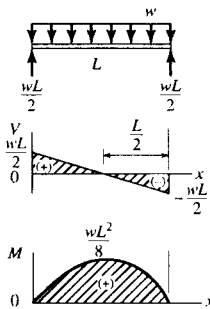

*7-48. Draw the shear and moment diagrams for the beam.

Support Reactions:

$$\curvearrowleft + \Sigma M_A = 0; \quad C_c(3) - 1.5(2.5) = 0 \quad C_c = 1.25 \text{ kN}$$

$$+ \uparrow \Sigma F_y = 0; \quad A_y - 1.5 + 1.25 = 0 \quad A_y = 0.250 \text{ kN}$$

Shear and Moment Functions: For $0 \leq x < 2 \text{ m}$ [FBD (a)],

$$+ \uparrow \Sigma F_y = 0; \quad 0.250 - V = 0 \quad V = 0.250 \text{ kN} \quad \text{Ans}$$

$$\curvearrowleft + \Sigma M = 0; \quad M - 0.250x = 0 \quad M = \{0.250x\} \text{ kN}\cdot\text{m}$$

Ans

For $2 \text{ m} < x \leq 3 \text{ m}$ [FBD (b)],

$$+ \uparrow \Sigma F_y = 0; \quad 0.25 - 1.5(x - 2) - V = 0$$

$$V = \{3.25 - 1.50x\} \text{ kN} \quad \text{Ans}$$

$$\curvearrowleft + \Sigma M = 0; \quad 0.25x - 1.5(x - 2)\left(\frac{x - 2}{2}\right) - M = 0$$

$$M = \{-0.750x^2 + 3.25x - 3.00\} \text{ kN}\cdot\text{m} \quad \text{Ans}$$

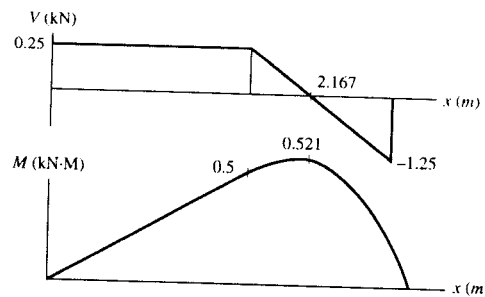
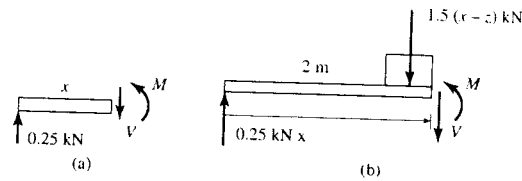
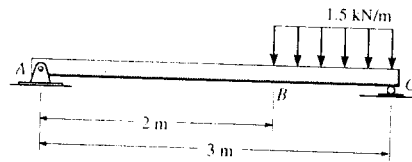

7-49. Draw the shear and bending-moment diagrams for the beam.

Support Reactions:

$$\curvearrowleft + \Sigma M_B = 0; \quad 1000(10) - 200 - A_y(20) = 0 \quad A_y = 490 \text{ lb}$$

Shear and Moment Functions: For $0 \leq x < 20 \text{ ft}$ [FBD (a)],

$$+ \uparrow \Sigma F_y = 0; \quad 490 - 50x - V = 0$$

$$V = \{490 - 50.0x\} \text{ lb} \quad \text{Ans}$$

$$\curvearrowleft + \Sigma M = 0; \quad M + 50x\left(\frac{x}{2}\right) - 490x = 0$$

$$M = \{490x - 25.0x^2\} \text{ lb}\cdot\text{ft} \quad \text{Ans}$$

For $20 \text{ ft} < x \leq 30 \text{ ft}$ [FBD (b)],

$$+ \uparrow \Sigma F_y = 0; \quad V = 0 \quad \text{Ans}$$

$$\curvearrowleft + \Sigma M = 0; \quad -200 - M = 0 \quad M = -200 \text{ lb}\cdot\text{ft} \quad \text{Ans}$$

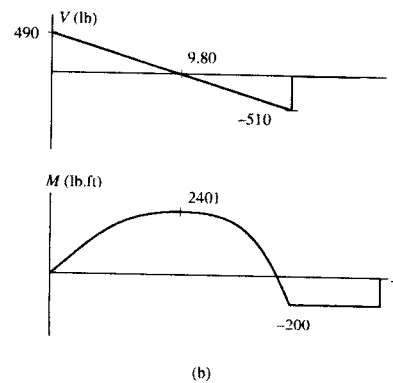
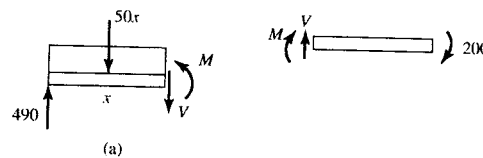
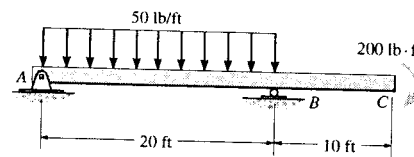

7-50. Draw the shear and moment diagrams for the beam.

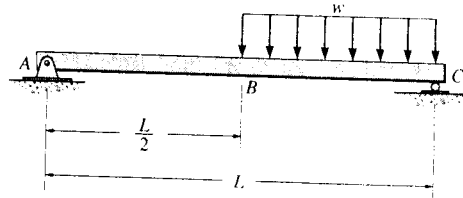

Support Reactions : From FBD (a),

$$\begin{aligned} +\Sigma M_A = 0; \quad C_y(L) - \frac{wL}{2}\left(\frac{3L}{4}\right) &= 0 \quad C_y = \frac{3wL}{8} \\ +\Sigma F_y = 0; \quad A_y + \frac{3wL}{8} - \frac{wL}{2} &= 0 \quad A_y = \frac{wL}{8} \end{aligned}$$

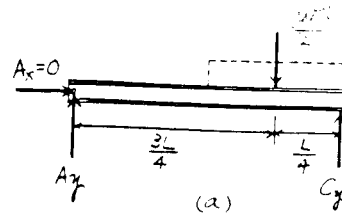

Shear and Moment Functions : For $0 \leq x < \frac{L}{2}$ [FBD (b)],

$$+\uparrow \Sigma F_y = 0; \quad \frac{wL}{8} - V = 0 \quad V = \frac{wL}{8} \quad \text{Ans}$$

$$(+\Sigma M = 0; \quad M - \frac{wL}{8}(x) = 0 \quad M = \frac{wL}{8}x \quad \text{Ans}$$

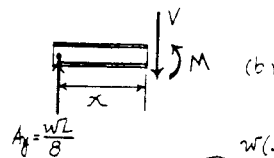

For $\frac{L}{2} < x \leq L$ [FBD (c)],

$$\begin{aligned} +\uparrow \Sigma F_y = 0; \quad V + \frac{3wL}{8} - w(L-x) &= 0 \\ V &= \frac{w}{8}(5L - 8x) \quad \text{Ans} \end{aligned}$$

$$\begin{aligned} (+\Sigma M = 0; \quad \frac{3wL}{8}(L-x) - w(L-x)\left(\frac{L-x}{2}\right) - M &= 0 \\ M &= \frac{w}{8}(-L^2 + 5Lx - 4x^2) \quad \text{Ans} \end{aligned}$$

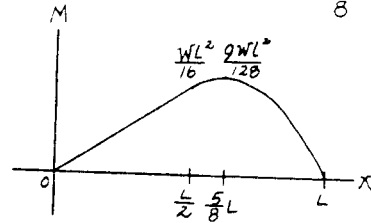
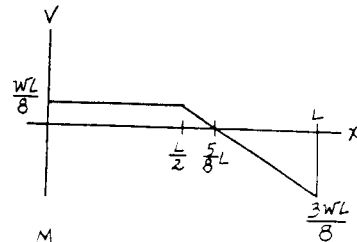
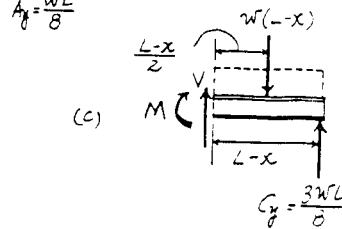

7-51. Draw the shear and moment diagrams for the beam.

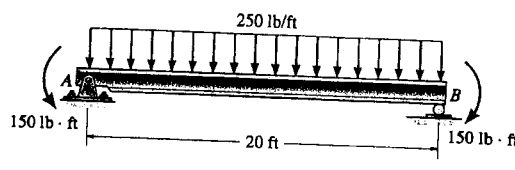

$$\begin{aligned} \sum M_A = 0; & \quad -5000(10) - 150 + B_y(20) = 0 \\ B_y = 2500 \text{ lb} \\ \sum F_x = 0; & \quad A_x = 0 \\ \sum F_y = 0; & \quad A_y - 5000 + 2500 = 0 \\ & \quad A_y = 2500 \text{ lb} \end{aligned}$$

For $0 \leq x \leq 20 \text{ ft}$

$$\begin{aligned} \sum F_y = 0; & \quad 2500 - 250x - V = 0 \\ & \quad V = 250(10 - x) \quad \text{Ans.} \\ \sum M = 0; & \quad -2500(x) + 150 + 250x\left(\frac{x}{2}\right) + M = 0 \\ & \quad M = 25(100x - 5x^2 - 6) \end{aligned}$$

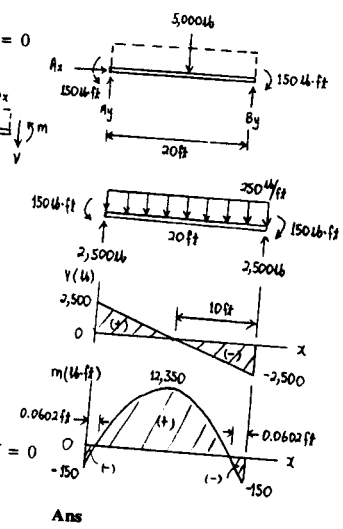

*7-52. Draw the shear and moment diagrams for the beam:

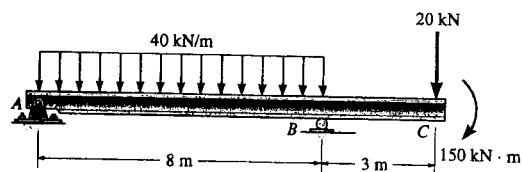

$0 \leq x < 8$

$$\begin{aligned} \sum F_y = 0; & \quad 133.75 - 40x - V = 0 \\ & \quad V = 133.75 - 40x \quad \text{Ans} \end{aligned}$$

$$\sum M = 0; \quad M + 40x\left(\frac{x}{2}\right) - 133.75x = 0$$

$$M = 133.75x - 20x^2 \quad \text{Ans}$$

$8 < x \leq 11$

$$\begin{aligned} \sum F_y = 0; & \quad V - 20 = 0 \\ & \quad V = 20 \quad \text{Ans} \end{aligned}$$

$$\begin{aligned} \sum M = 0; & \quad M + 20(11 - x) + 150 = 0 \\ & \quad M = 20x - 370 \quad \text{Ans} \end{aligned}$$

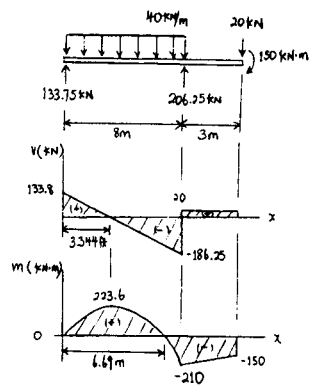

7-53. Draw the shear and bending-moment diagrams for each of the two segments of the compound beam.

Support Reactions : From FBD (a).

$$\begin{aligned} \sum M_A = 0; & B_y(12) - 2100(7) = 0 & B_y = 1225 \text{ lb} \\ + \uparrow \sum F_y = 0; & A_y + 1225 - 2100 = 0 & A_y = 875 \text{ lb} \end{aligned}$$

From FBD (b),

$$\begin{aligned} \sum M_D = 0; & 1225(6) - C_y(8) = 0 & C_y = 918.75 \text{ lb} \\ + \uparrow \sum F_y = 0; & D_y + 918.75 - 1225 = 0 & D_y = 306.25 \text{ lb} \end{aligned}$$

Shear and Moment Functions : Member AB.

For $0 \leq x < 12 \text{ ft}$ [FBD (c)].

$$\begin{aligned} + \uparrow \sum F_y = 0; & 875 - 150x - V = 0 \\ & V = \{875 - 150x\} \text{ lb} \end{aligned} \quad \text{Ans}$$

$$\begin{aligned} \sum M = 0; & M + 150x\left(\frac{x}{2}\right) - 875x = 0 \\ & M = \{875x - 75.0x^2\} \text{ lb} \cdot \text{ft} \end{aligned} \quad \text{Ans}$$

For $12 \text{ ft} < x \leq 14 \text{ ft}$ [FBD (d)].

$$\begin{aligned} + \uparrow \sum F_y = 0; & V - 150(14-x) = 0 \\ & V = \{2100 - 150x\} \text{ lb} \end{aligned} \quad \text{Ans}$$

$$\begin{aligned} \sum M = 0; & -150(14-x)\left(\frac{14-x}{2}\right) - M = 0 \\ & M = \{-75.0x^2 + 2100x - 14700\} \text{ lb} \cdot \text{ft} \end{aligned} \quad \text{Ans}$$

For member CBD, $0 \leq x < 2 \text{ ft}$ [FBD (e)].

$$+ \uparrow \sum F_y = 0; \quad 918.75 - V = 0 \quad V = 919 \text{ lb} \quad \text{Ans}$$

$$\sum M = 0; \quad 918.75x - M = 0 \quad M = \{919x\} \text{ lb} \cdot \text{ft} \quad \text{Ans}$$

For $2 \text{ ft} < x \leq 8 \text{ ft}$ [FBD (f)].

$$+ \uparrow \sum F_y = 0; \quad V + 306.25 = 0 \quad V = -306 \text{ lb} \quad \text{Ans}$$

$$\sum M = 0; \quad 306.25(8-x) - M = 0 \\ M = \{2450 - 306x\} \text{ lb} \cdot \text{ft} \quad \text{Ans}$$

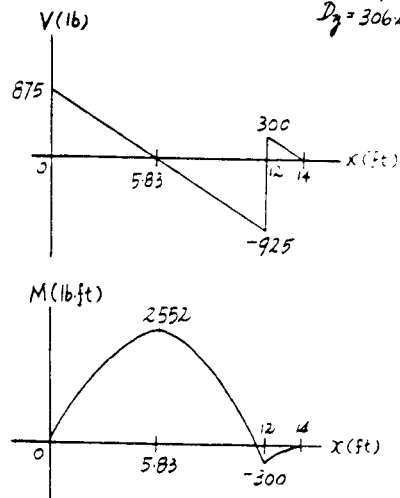
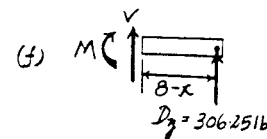
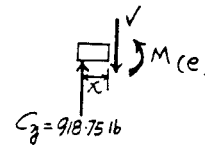
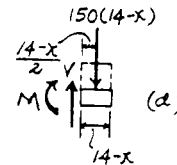
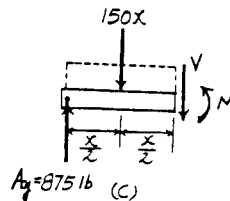
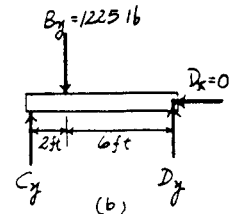
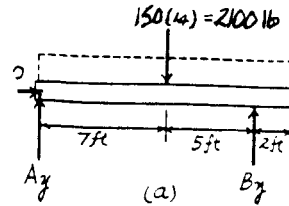
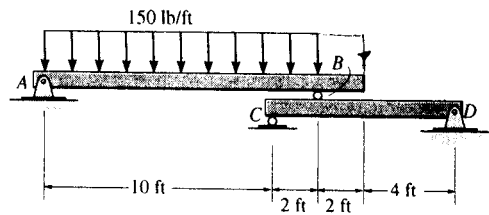
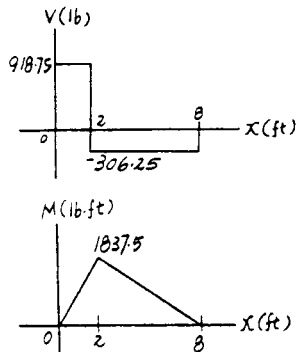

7-54. Draw the shear and bending-moment diagrams for beam ABC. Note that there is a pin at B.

Support Reactions : From FBD (a).

$$\left(+\Sigma M_C = 0; \frac{wL}{2} \left(\frac{L}{4} \right) - B_y \left(\frac{L}{2} \right) = 0 \quad B_y = \frac{wL}{4} \right.$$

From FBD (b).

$$+\uparrow \Sigma F_y = 0; \quad A_y - \frac{wL}{2} - \frac{wL}{4} = 0 \quad A_y = \frac{3wL}{4}$$

Shear and Moment Functions : For $0 \leq x \leq L$ [FBD (c)].

$$+\uparrow \Sigma F_y = 0; \quad \frac{3wL}{4} - wx - V = 0$$

$$V = \frac{w}{4} (3L - 4x) \quad \text{Ans}$$

$$\left(+\Sigma M = 0; \quad \frac{3wL}{4} (x) - wx \left(\frac{x}{2} \right) - \frac{wL^2}{4} - M = 0 \right.$$

$$M = \frac{w}{4} (3Lx - 2x^2 - L^2) \quad \text{Ans}$$

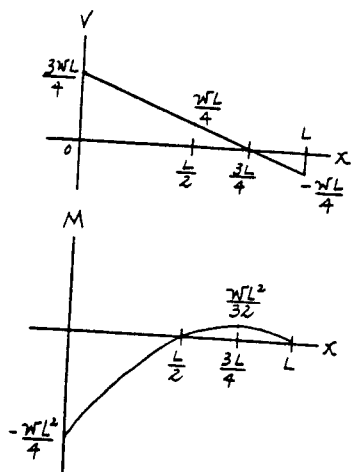
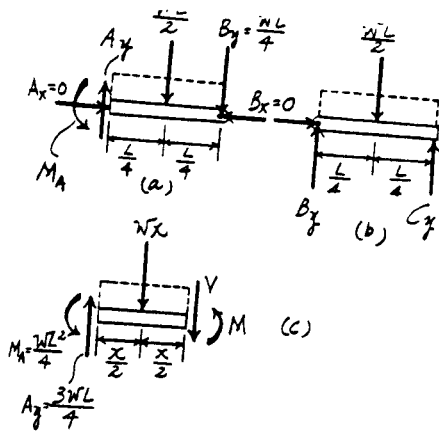
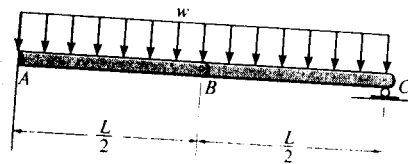

7-55. Draw the shear and moment diagrams for the compound beam. The beam is pin-connected at E and F.

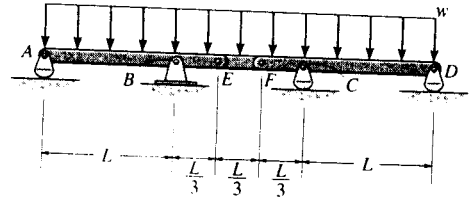

Support Reactions : From FBD (b),

$$\begin{aligned} \circlearrowleft + \Sigma M_E = 0; \quad F_y \left(\frac{L}{3}\right) - \frac{wL}{3} \left(\frac{L}{6}\right) &= 0 \quad F_y = \frac{wL}{6} \\ + \uparrow \Sigma F_y = 0; \quad E_y + \frac{wL}{6} - \frac{wL}{3} &= 0 \quad E_y = \frac{wL}{6} \end{aligned}$$

From FBD (a),

$$\circlearrowleft + \Sigma M_C = 0; \quad D_y(L) + \frac{wL}{6} \left(\frac{L}{3}\right) - \frac{4wL}{3} \left(\frac{L}{3}\right) = 0 \quad D_y = \frac{7wL}{18}$$

From FBD (c),

$$\begin{aligned} \circlearrowleft + \Sigma M_B = 0; \quad \frac{4wL}{3} \left(\frac{L}{3}\right) - \frac{wL}{6} \left(\frac{L}{3}\right) - A_y(L) &= 0 \quad A_y = \frac{7wL}{18} \\ + \uparrow \Sigma F_y = 0; \quad B_y + \frac{7wL}{18} - \frac{4wL}{3} - \frac{wL}{6} &= 0 \quad B_y = \frac{10wL}{9} \end{aligned}$$

Shear and Moment Functions : For $0 \leq x < L$ [FBD (d)],

$$\begin{aligned} + \uparrow \Sigma F_y = 0; \quad \frac{7wL}{18} - wx - V &= 0 \\ V &= \frac{w}{18}(7L - 18x) \end{aligned}$$

$$\begin{aligned} \circlearrowleft + \Sigma M = 0; \quad M + wx \left(\frac{x}{2}\right) - \frac{7wL}{18}x &= 0 \\ M &= \frac{w}{18}(7Lx - 9x^2) \end{aligned}$$

For $L \leq x < 2L$ [FBD (e)],

$$\begin{aligned} + \uparrow \Sigma F_y = 0; \quad \frac{7wL}{18} + \frac{10wL}{9} - wx - V &= 0 \\ V &= \frac{w}{2}(3L - 2x) \end{aligned}$$

$$\begin{aligned} \circlearrowleft + \Sigma M = 0; \quad M + wx \left(\frac{x}{2}\right) - \frac{7wL}{18}x - \frac{10wL}{9}(x-L) &= 0 \\ M &= \frac{w}{18}(27Lx - 20L^2 - 9x^2) \end{aligned}$$

For $2L < x \leq 3L$ [FBD (f)],

$$\begin{aligned} + \uparrow \Sigma F_y = 0; \quad V + \frac{7wL}{18} - w(3L-x) &= 0 \\ V &= \frac{w}{18}(47L - 18x) \end{aligned}$$

$$\begin{aligned} \circlearrowleft + \Sigma M = 0; \quad \frac{7wL}{18}(3L-x) - w(3L-x) \left(\frac{3L-x}{2}\right) - M &= 0 \\ M &= \frac{w}{18}(47Lx - 9x^2 - 60L^2) \end{aligned}$$

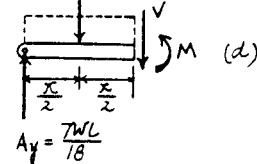
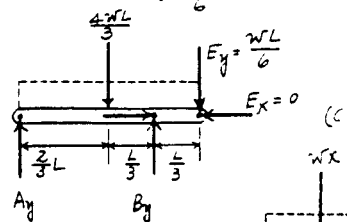
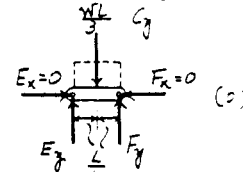
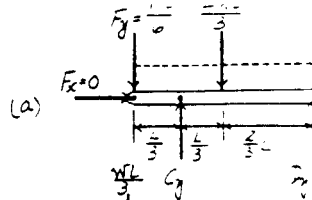

Ans

Ans

Ans

Ans

Ans

Ans

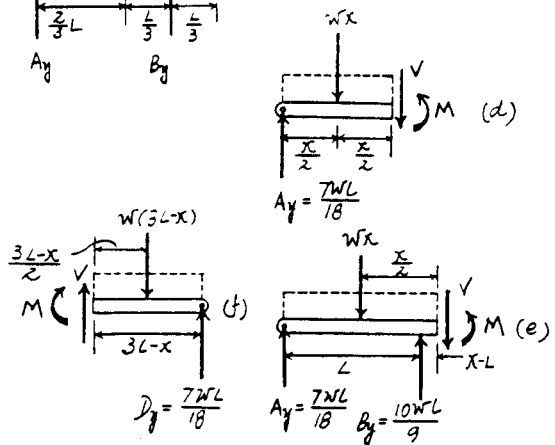

*7-56. Draw the shear and moment diagrams for the beam.

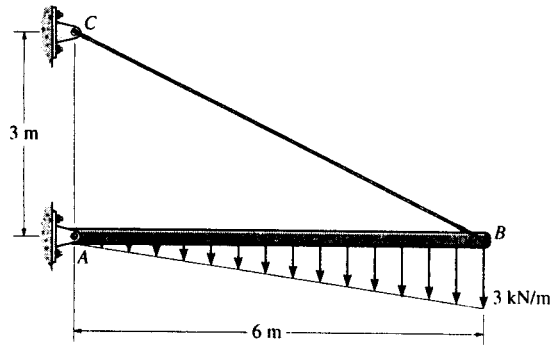

Support Reactions : From FBD (a),

$$(+\Sigma M_B = 0; \quad 9.00(2) - A_y(6) = 0 \quad A_y = 3.00 \text{ kN}$$

Shear and Moment Functions : For $0 \leq x \leq 6 \text{ m}$ [FBD (b)].

$$+\uparrow \Sigma F_y = 0; \quad 3.00 - \frac{x^2}{4} - V = 0$$

$$V = \left\{ 3.00 - \frac{x^2}{4} \right\} \text{ kN}$$

Ans

The maximum moment occurs when $V = 0$, then

$$0 = 3.00 - \frac{x^2}{4} \quad x = 3.464 \text{ m}$$

$$(+\Sigma M = 0; \quad M + \left(\frac{x^2}{4}\right)\left(\frac{x}{3}\right) - 3.00x = 0$$

$$M = \left\{ 3.00x - \frac{x^3}{12} \right\} \text{ kN} \cdot \text{m}$$

Ans

Thus,

$$M_{\max} = 3.00(3.464) - \frac{3.464^3}{12} = 6.93 \text{ kN} \cdot \text{m}$$

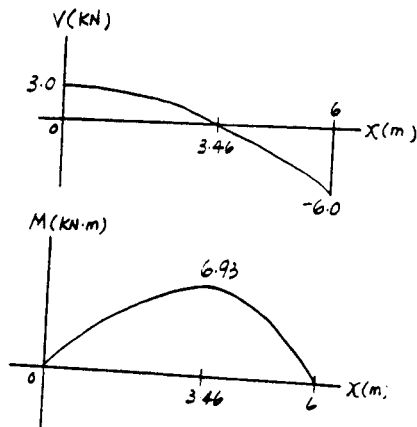
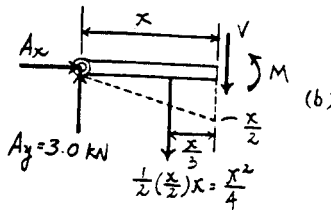
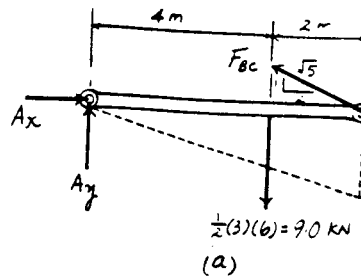

7-57. If $L = 18$ ft, the beam will fail when the maximum shear force is $V_{\max} = 800$ lb or the maximum moment is $M_{\max} = 1200$ lb-ft. Determine the largest intensity w of the distributed loading it will support.

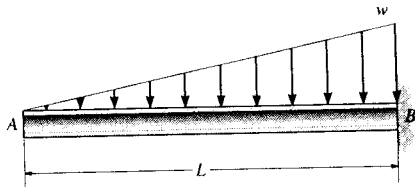

For $0 \leq x \leq L$

$$+\uparrow \Sigma F_y = 0; \quad V = -\frac{wx^2}{2L}$$

$$\curvearrowleft + \Sigma M = 0; \quad M = -\frac{wx^3}{6L}$$

$$V_{\max} = \frac{-wL}{2}$$

$$-800 = \frac{-w(18)}{2}$$

$$w = 88.9 \text{ lb/ft}$$

$$M_{\max} = -\frac{wL^2}{6}$$

$$-1200 = \frac{-w(18)^2}{6}$$

$$w = 22.2 \text{ lb/ft}$$

Ans

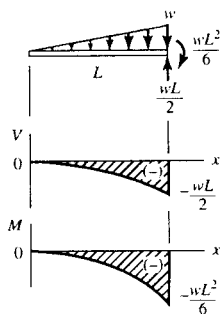
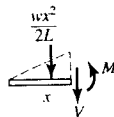

7-58. The beam will fail when the maximum internal moment is M_{max} . Determine the position x of the concentrated force P and its smallest magnitude that will cause failure.

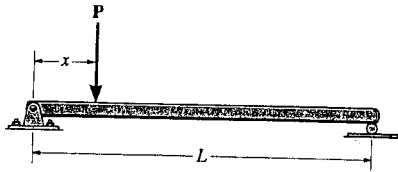

For $\xi < x$,

$$M_1 = \frac{P\xi(L-x)}{L}$$

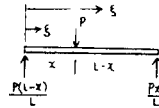

For $\xi > x$,

$$M_2 = -\frac{Px}{L}(L-\xi)$$

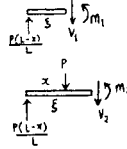

Note that $M_1 = M_2$ when $x = \xi$

$$M_{max} = M_1 = M_2 = \frac{Px}{L}(L-x)$$

$$\frac{dM_{max}}{dx} = \frac{P}{L}(L-2x) = 0$$

$$x = \frac{L}{2} \quad \text{Ans}$$

Thus, $M_{max} = \frac{P}{L} \left(\frac{L}{2}\right) \left(L - \frac{L}{2}\right) = \frac{P}{2} \left(\frac{L}{2}\right)$

$$P = \frac{4M_{max}}{L} \quad \text{Ans}$$

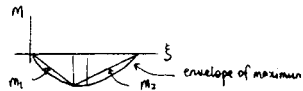

7-59. Draw the shear and moment diagrams for the beam.

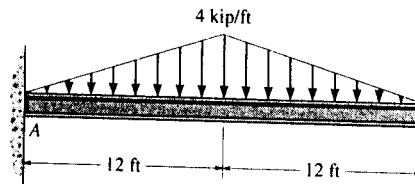

Support Reactions : From FBD (a).

$$\begin{aligned} \sum M_A = 0; \quad M_A - 48.0(12) = 0 \quad M_A = 576 \text{ kip} \cdot \text{ft} \\ \sum F_y = 0; \quad A_y - 48.0 = 0 \quad A_y = 48.0 \text{ kip} \end{aligned}$$

Shear and Moment Functions : For $0 \leq x < 12 \text{ ft}$ [FBD (b)].

$$+\uparrow \sum F_y = 0; \quad 48.0 - \frac{x^2}{6} - V = 0$$

$$V = \left\{ 48.0 - \frac{x^2}{6} \right\} \text{ kip}$$

Ans

$$\sum M = 0; \quad M + \frac{x^2}{6} \left(\frac{x}{3} \right) + 576 - 48.0x = 0$$

$$M = \left\{ 48.0x - \frac{x^3}{18} - 576 \right\} \text{ kip} \cdot \text{ft}$$

Ans

For $12 \text{ ft} < x \leq 24 \text{ ft}$ [FBD (c)].

$$+\uparrow \sum F_y = 0; \quad V - \frac{1}{2} \left[\frac{1}{3} (24-x) \right] (24-x) = 0$$

$$V = \left\{ \frac{1}{6} (24-x)^2 \right\} \text{ kip}$$

Ans

$$\sum M = 0; \quad -\frac{1}{2} \left[\frac{1}{3} (24-x) \right] (24-x) \left(\frac{24-x}{3} \right) - M = 0$$

$$M = \left\{ -\frac{1}{18} (24-x)^3 \right\} \text{ kip} \cdot \text{ft}$$

Ans

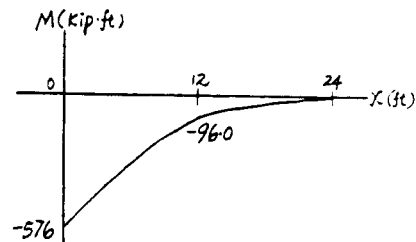
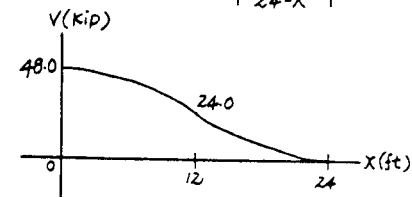
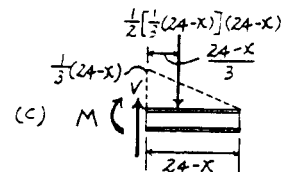
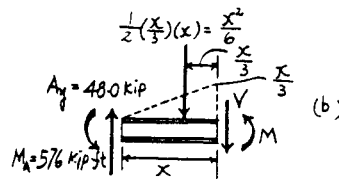
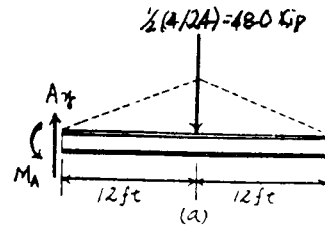

*7-60. Draw the shear and bending-moment diagrams for the beam.

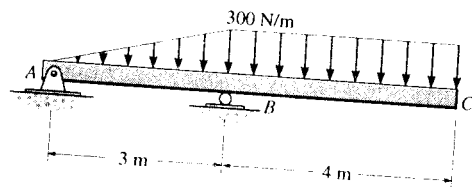

Support Reactions : From FBD (a),

$$\circlearrowleft + \Sigma M_B = 0; \quad A_y(3) + 450(1) - 1200(2) = 0 \quad A_y = 650 \text{ N}$$

Shear and Moment Functions : For $0 \leq x < 3 \text{ m}$ [FBD (b)],

$$+ \uparrow \Sigma F_y = 0; \quad -650 - 50.0x^2 - V = 0$$

$$V = \{-650 - 50.0x^2\} \text{ N} \quad \text{Ans}$$

$$\circlearrowleft + \Sigma M = 0; \quad M + (50.0x^2)\left(\frac{x}{3}\right) + 650x = 0$$

$$M = \{-650x - 16.7x^3\} \text{ N} \cdot \text{m} \quad \text{Ans}$$

For $3 \text{ m} < x \leq 7 \text{ m}$ [FBD (c)],

$$+ \uparrow \Sigma F_y = 0; \quad V - 300(7-x) = 0$$

$$V = \{2100 - 300x\} \text{ N} \quad \text{Ans}$$

$$\circlearrowleft + \Sigma M = 0; \quad -300(7-x)\left(\frac{7-x}{2}\right) - M = 0$$

$$M = \{-150(7-x)^2\} \text{ N} \cdot \text{m} \quad \text{Ans}$$

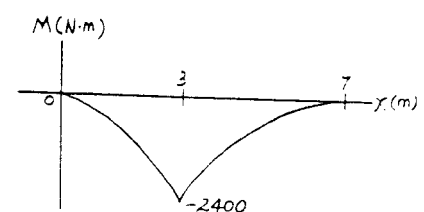
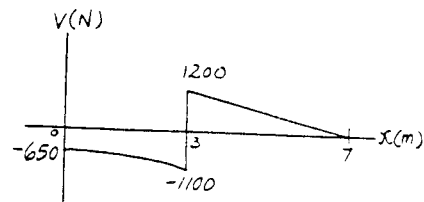
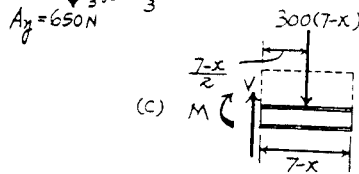
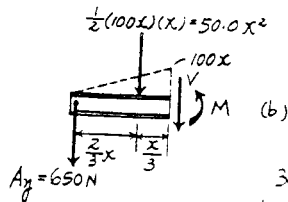
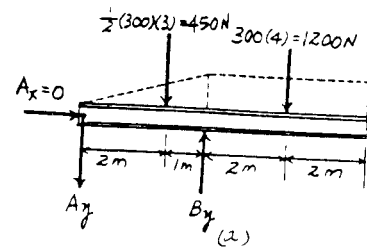

7-61. Draw the shear and moment diagrams for the beam.

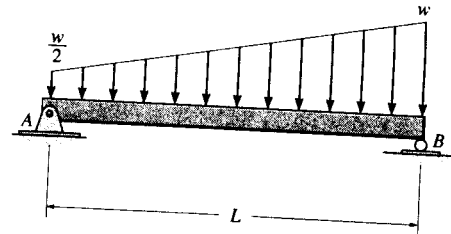

Support Reactions : From FBD (a).

$$\sum M_B = 0; \quad \frac{wL}{4} \left(\frac{L}{3}\right) + \frac{wL}{2} \left(\frac{L}{2}\right) - A_y(L) = 0 \quad A_y = \frac{wL}{3}$$

Shear and Moment Functions : For $0 \leq x \leq L$ [FBD (b)].

$$\begin{aligned} + \uparrow \sum F_y = 0; \quad \frac{wL}{3} - \frac{w}{2}x - \frac{1}{2} \left(\frac{w}{2L}x\right)x - V = 0 \\ V = \frac{w}{12L} (4L^2 - 6Lx - 3x^2) \quad \text{Ans} \end{aligned}$$

The maximum moment occurs when $V = 0$, then

$$0 = 4L^2 - 6Lx - 3x^2 \quad x = 0.5275L$$

$$\begin{aligned} \sum M = 0; \quad M + \frac{1}{2} \left(\frac{w}{2L}x\right)x \left(\frac{x}{3}\right) + \frac{wx}{2} \left(\frac{x}{2}\right) - \frac{wL}{3}(x) = 0 \\ M = \frac{w}{12L} (4L^2x - 3Lx^2 - x^3) \quad \text{Ans} \end{aligned}$$

Thus,

$$\begin{aligned} M_{\max} &= \frac{w}{12L} [4L^2(0.5275L) - 3L(0.5275L)^2 - (0.5275L)^3] \\ &= 0.0940wL^2 \quad \text{Ans.} \end{aligned}$$

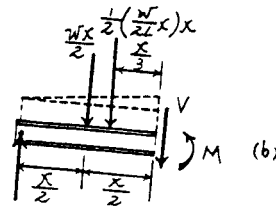
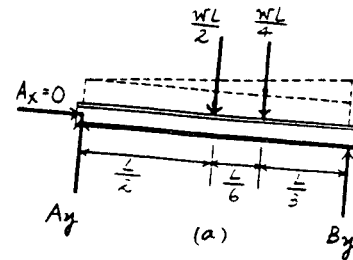

$$A_y = \frac{wL}{3}$$

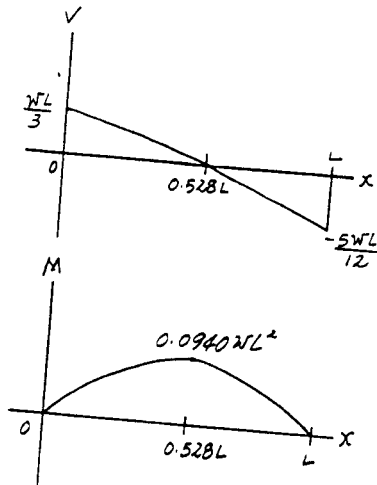

7-62. Draw the shear and moment diagrams for the beam
 (a) in terms of the parameters shown; (b) set $P = 800$ lb,
 $a = 5$ ft, $L = 12$ ft.

(a) For $0 \leq x < a$

$$+\uparrow \Sigma F_y = 0; \quad V = P$$

Ans

$$\curvearrowleft +\Sigma M = 0; \quad M = Px$$

Ans

For $a < x < L - a$

$$+\uparrow \Sigma F_y = 0; \quad V = 0$$

Ans

$$\curvearrowleft +\Sigma M = 0; \quad -Px + P(x - a) + M = 0$$

$$M = Pa$$

Ans

For $L - a < x \leq L$

$$+\uparrow \Sigma F_y = 0; \quad V = -P$$

Ans

$$\curvearrowleft +\Sigma M = 0; \quad -M + P(L - x) = 0$$

$$M = P(L - x)$$

Ans

(b) Set $P = 800$ lb, $a = 5$ ft, $L = 12$ ft

For $0 \leq x \leq 5$ ft

$$+\uparrow \Sigma F_y = 0; \quad V = 800 \text{ lb}$$

Ans

$$\curvearrowleft +\Sigma M = 0; \quad M = 800x \text{ lb}\cdot\text{ft}$$

Ans

For $5 \text{ ft} < x < 7 \text{ ft}$

$$+\uparrow \Sigma F_y = 0; \quad V = 0$$

Ans

$$\curvearrowleft +\Sigma M = 0; \quad -800x + 800(x - 5) + M = 0$$

$$M = 4000 \text{ lb}\cdot\text{ft}$$

Ans

For $7 \text{ ft} < x \leq 12 \text{ ft}$

$$+\uparrow \Sigma F_y = 0; \quad V = -800 \text{ lb}$$

Ans

$$\curvearrowleft +\Sigma M = 0; \quad -M + 800(12 - x) = 0$$

$$M = (9600 - 800x) \text{ lb}\cdot\text{ft}$$

Ans

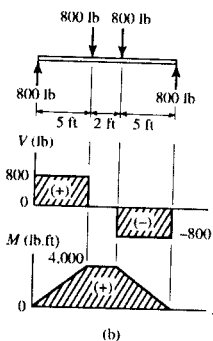
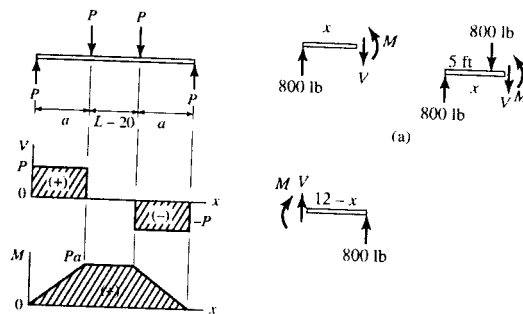
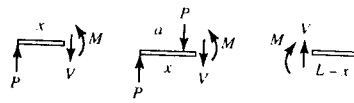
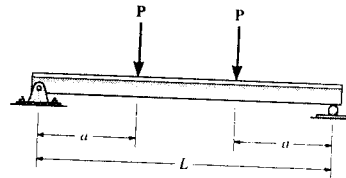

7-63. Express the x , y , z components of internal loading
 in the rod as a function of y , where $0 \leq y \leq 4$ ft.

For $0 \leq y \leq 4$ ft

$$\Sigma F_x = 0; \quad V_x = 1500 \text{ lb} = 1.5 \text{ kip} \quad \text{Ans}$$

$$\Sigma F_y = 0; \quad V_y = 0 \quad \text{Ans}$$

$$\Sigma F_z = 0; \quad V_z = 800(4 - y) \text{ lb} \quad \text{Ans}$$

$$\Sigma M_x = 0; \quad M_x - 800(4 - y) \left(\frac{4 - y}{2} \right) = 0$$

$$M_x = 400(4 - y)^2 \text{ lb}\cdot\text{ft} \quad \text{Ans}$$

$$\Sigma M_y = 0; \quad M_y + 1500(2) = 0$$

$$M_y = -3000 \text{ lb}\cdot\text{ft} = -3 \text{ kip}\cdot\text{ft} \quad \text{Ans}$$

$$\Sigma M_z = 0; \quad M_z + 1500(4 - y) = 0$$

$$M_z = -1500(4 - y) \text{ lb}\cdot\text{ft} \quad \text{Ans}$$

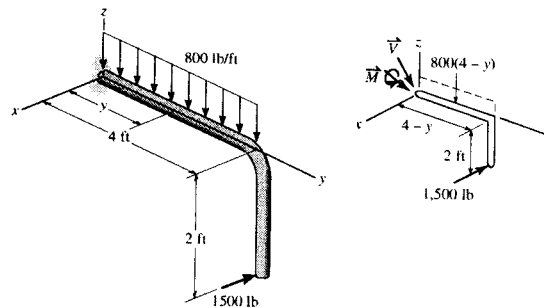

*7-64. Determine the normal force, shear force, and moment in the curved rod as a function of θ .

For $0 \leq \theta \leq 180^\circ$

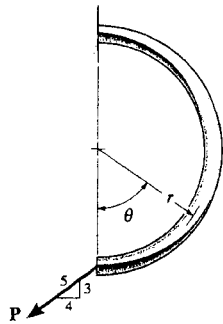

$$\sum F_x = 0; \quad N - \frac{4}{5}P \cos \theta - \frac{3}{5}P \sin \theta = 0$$

$$N = \frac{P}{5}(4 \cos \theta + 3 \sin \theta) \quad \text{Ans}$$

$$\sum F_y = 0; \quad V - \frac{4}{5}P \sin \theta + \frac{3}{5}P \cos \theta = 0$$

$$V = \frac{P}{5}(4 \sin \theta - 3 \cos \theta) \quad \text{Ans}$$

$$\sum M = 0; \quad -\frac{4}{5}P(r - r \cos \theta) + \frac{3}{5}P(r \sin \theta) + M = 0$$

$$M = \frac{Pr}{5}(4 - 4 \cos \theta - 3 \sin \theta) \quad \text{Ans}$$

Also,

$$\sum M = 0; \quad -P\left(\frac{4}{5}\right)(r) + N(r) + M = 0$$

$$M = \frac{Pr}{5}(4 - 4 \cos \theta - 3 \sin \theta) \quad \text{Ans}$$

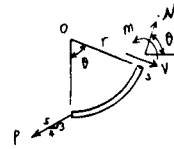

7-65. Express the internal shear and moment components acting in the rod as a function of y , where $0 \leq y \leq 4$ ft.

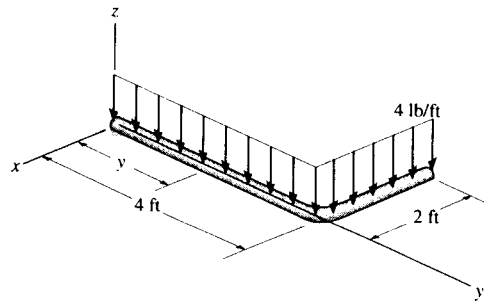

Shear and Moment Functions :

$$\sum F_x = 0; \quad V_x = 0$$

Ans

$$\sum F_z = 0; \quad V_z - 4(4-y) - 8.00 = 0$$

$$V_z = \{24.0 - 4y\} \text{ lb}$$

Ans

$$\sum M_x = 0; \quad M_x - 4(4-y)\left(\frac{4-y}{2}\right) - 8.00(4-y) = 0$$

$$M_x = \{2y^2 - 24y + 64.0\} \text{ lb} \cdot \text{ft}$$

Ans

$$\sum M_y = 0; \quad M_y - 8.00(1) = 0 \quad M_y = 8.00 \text{ lb} \cdot \text{ft}.$$

Ans

$$\sum M_z = 0; \quad M_z = 0$$

Ans

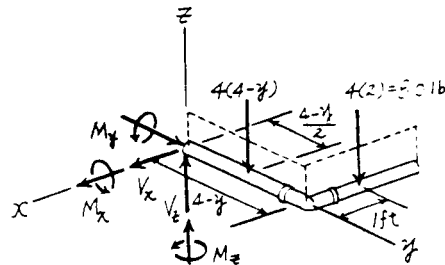

7-66. Draw the shear and moment diagrams for the beam.

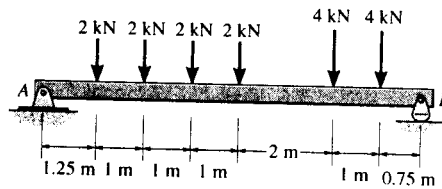

Support Reactions :

$$\begin{aligned} \sum M_A = 0: & B_y(8) - 4(7.25) - 4(6.25) - 2(4.25) \\ & \quad - 2(3.25) - 2(2.25) - 2(1.25) = 0 \\ & B_y = 9.50 \text{ kN} \\ \sum F_y = 0: & A_y + 9.50 - 2 - 2 - 2 - 2 - 4 - 4 = 0 \\ & A_y = 6.50 \text{ kN} \end{aligned}$$

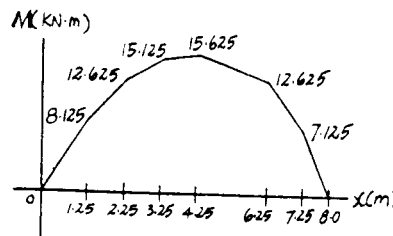
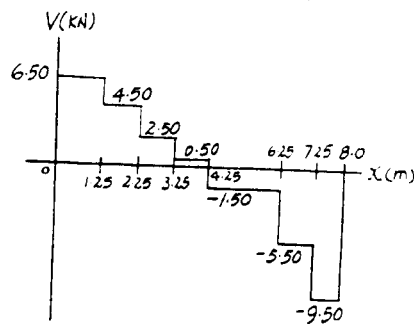
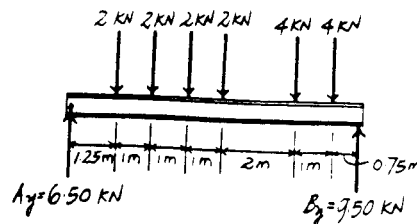

7-67. Draw the shear and moment diagrams for the beam $ABCDE$. All pulleys have a radius of 1 ft. Neglect the weight of the beam and pulley arrangement. The load weighs 500 lb.

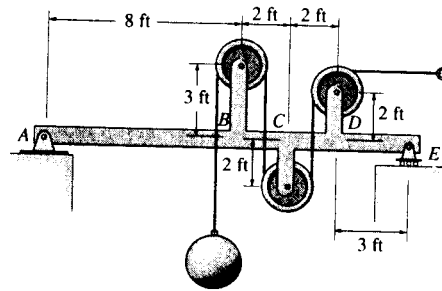

Support Reactions : From FBD (a),

$$\begin{aligned} \left(+\Sigma M_A = 0; \quad E_y(15) - 500(7) - 500(3) = 0 \quad E_y = 333.33 \text{ lb} \right. \\ \left. +\uparrow \Sigma F_y = 0; \quad A_y + 333.33 - 500 = 0 \quad A_y = 166.67 \text{ lb} \right. \end{aligned}$$

Shear and Moment Diagrams : The load on the pulley at D can be replaced by equivalent force and couple moment at D as shown on FBD (b).

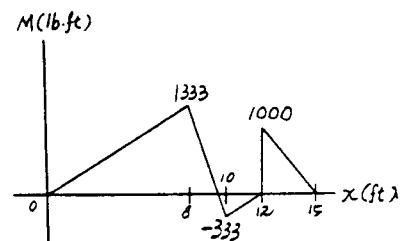
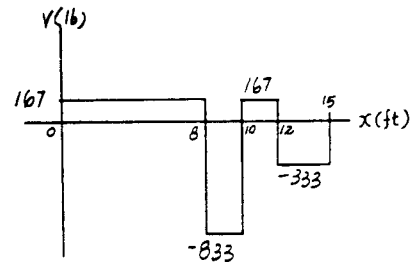
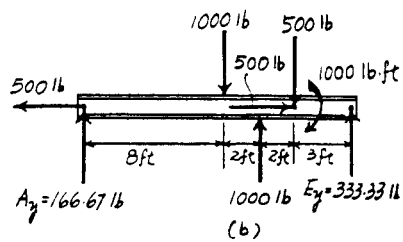
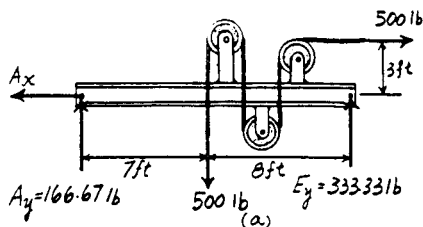

*7-68. Draw the shear and moment diagrams for the beam.

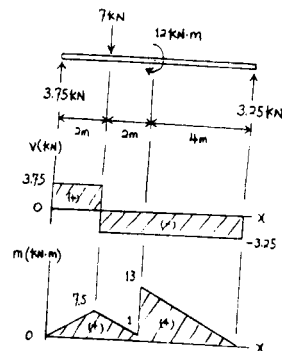
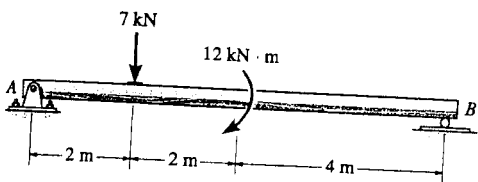

7-69. Draw the shear and moment diagrams for the beam.

Support Reactions :

$$\sum M_A = 0; \quad F_C \left(\frac{3}{5}\right)(4) - 500(2) - 500(1) = 0 \quad F_C = 625 \text{ N}$$

$$\sum F_y = 0; \quad A_y + 625 \left(\frac{3}{5}\right) - 500 - 500 = 0 \quad A_y = 625 \text{ N}$$

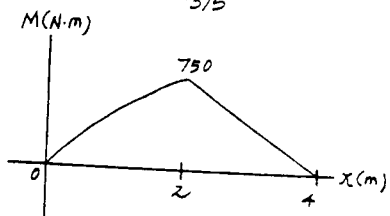
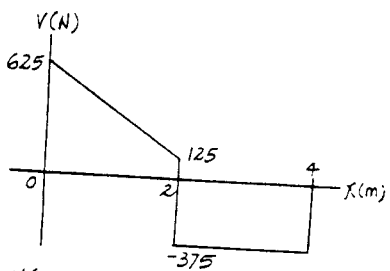
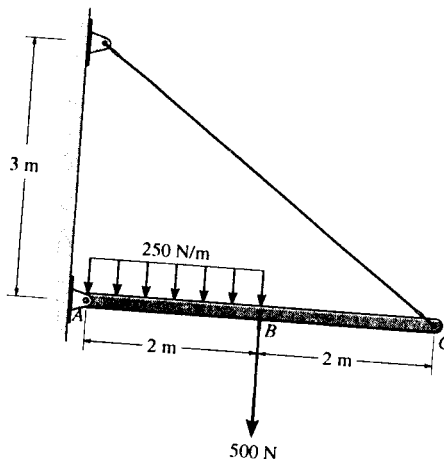
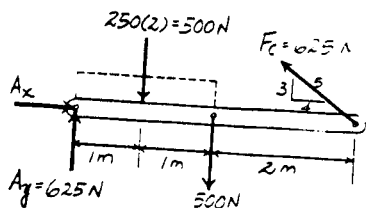

7-70. Draw the shear and moment diagrams for the beam.

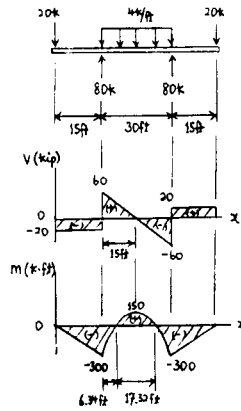
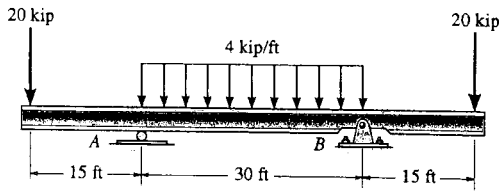

7-71. Draw the shear and moment diagrams for the beam.

Support Reactions :

$$\begin{aligned} \sum M_A = 0; & \quad B_y(8) - 320(4) - 20(11) - 150 = 0 \\ & \quad B_y = 206.25 \text{ kN} \\ \sum F_y = 0; & \quad A_y + 206.25 - 320 - 20 = 0 \quad A_y = 133.75 \text{ kN} \end{aligned}$$

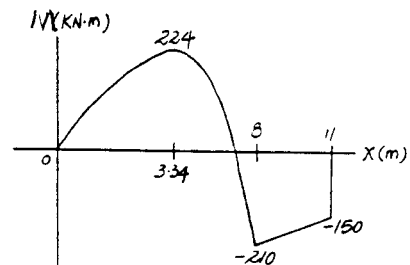
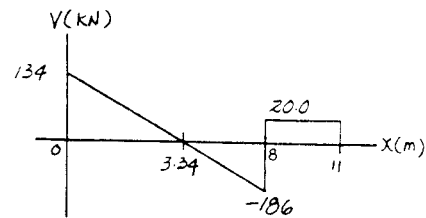
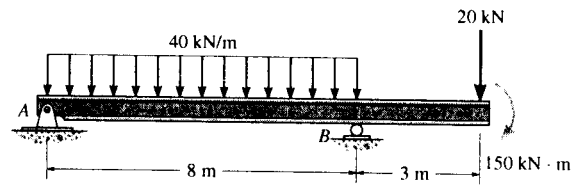
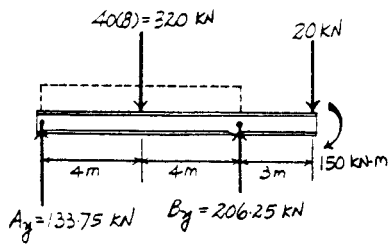

*7-72. Draw the shear and moment diagrams for the shaft. The support at A is a journal bearing and at B it is a thrust bearing.

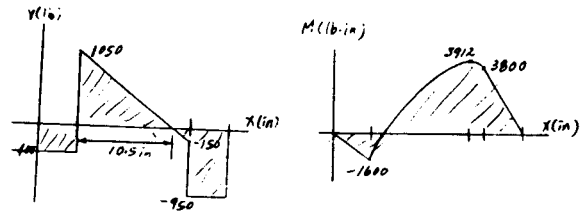
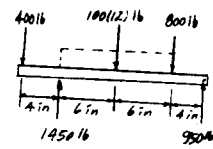
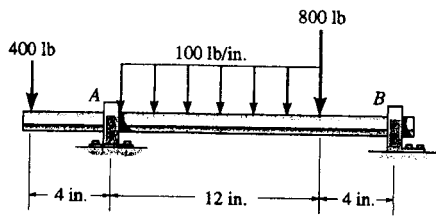

7-73. Draw the shear and moment diagrams for the beam.

Support Reactions :

$$\begin{aligned} +\Sigma M_A = 0; & B_y(10) - 10.0(2.5) - 10(8) = 0 \quad B_y = 10.5 \text{ kN} \\ +\uparrow \Sigma F_y = 0; & A_y + 10.5 - 10.0 - 10 = 0 \quad A_y = 9.50 \text{ kN} \end{aligned}$$

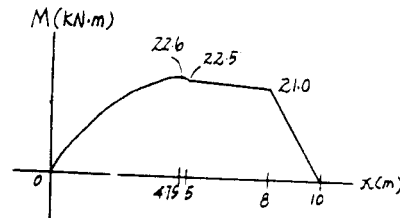
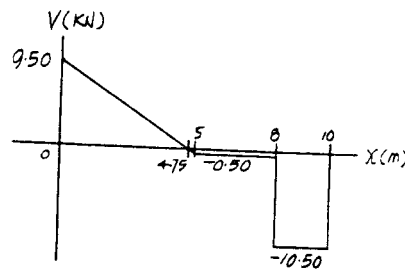
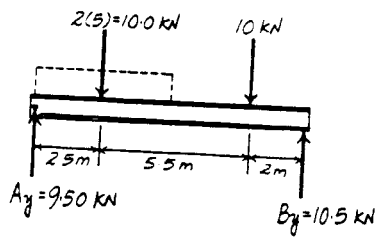
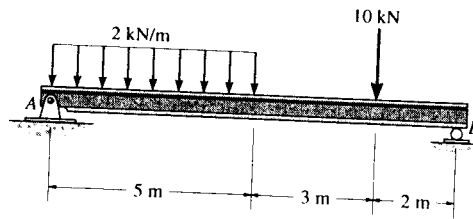

7-74. Draw the shear and moment diagrams for the shaft. The support at A is a journal bearing and at B it is a thrust bearing.

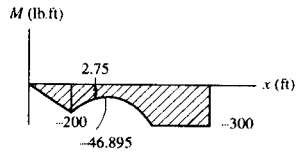
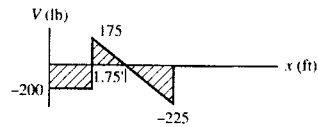
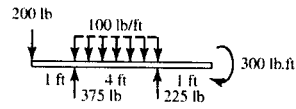
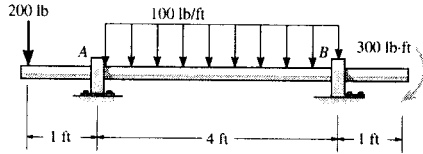

7-75. Draw the shear and moment diagrams for the beam.

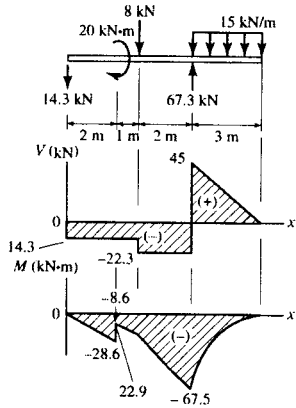
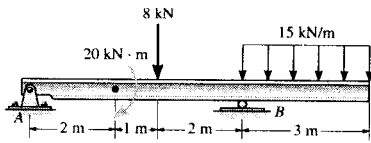

*7-76. Draw the shear and moment diagrams for the shaft. The support at A is a thrust bearing and at B it is a journal bearing.

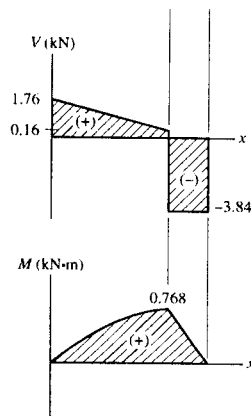
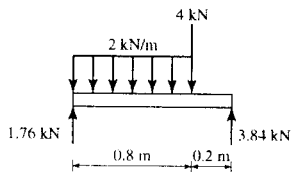
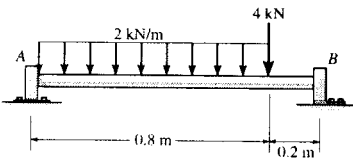

7-77. Draw the shear and moment diagrams for the beam.

Support Reactions :

$$\sum M_A = 0: D_y(3) - 8(1) - 8(2) - 15.0(3.5) - 20 = 0$$

$$D_y = 32.167 \text{ kN}$$

$$+\uparrow \sum F_y = 0: 32.167 - 8 - 8 - 15.0 - A_y = 0$$

$$A_y = 1.167 \text{ kN}$$

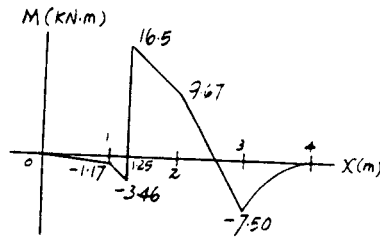
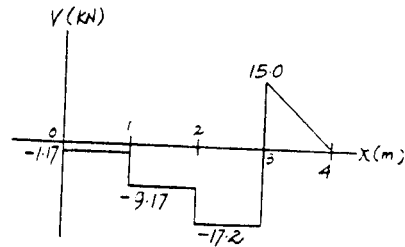
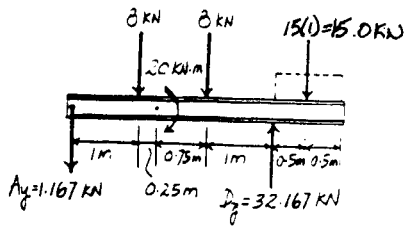
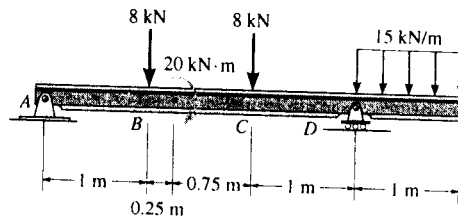

7-78. The beam will fail when the maximum moment is $M_{\max} = 30 \text{ kip} \cdot \text{ft}$ or the maximum shear is $V_{\max} = 8 \text{ kip}$. Determine the largest distributed load w the beam will support.

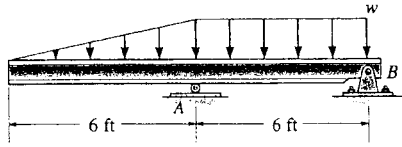

$$V_{\max} = 4w; \quad 8 = 4w$$

$$w = 2 \text{ kip/ft}$$

$$M_{\max} = -6w; \quad -30 = -6w$$

$$w = 5 \text{ kip/ft}$$

Thus, $w = 2 \text{ kip/ft}$ **Ans**

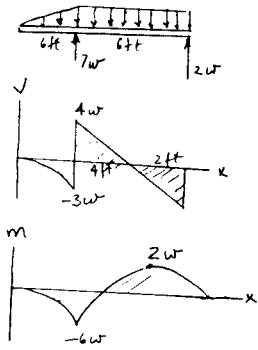

7-79. The beam consists of two segments pin connected at B. Draw the shear and moment diagrams for the beam.

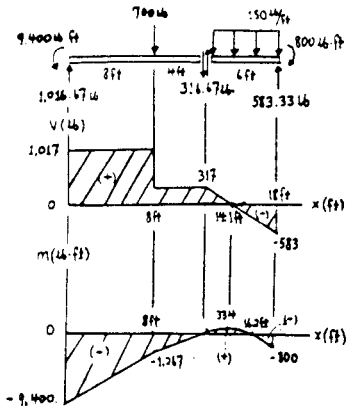
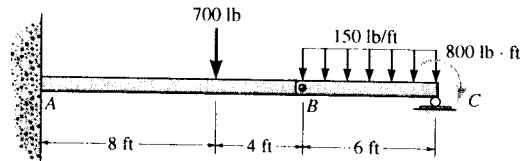

*7-80. Draw the shear and moment diagrams for the beam.

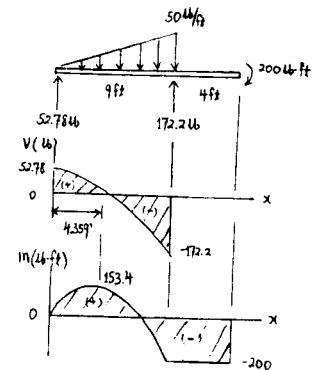
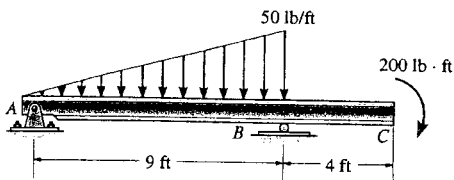

7-81. The beam consists of two segments pin-connected at B . Draw the shear and moment diagrams for the beam.

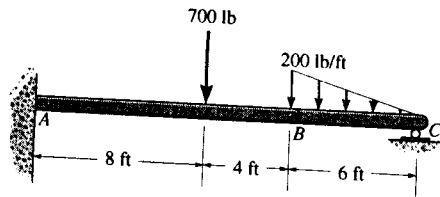

Support Reactions : From FBD (a),

$$\begin{aligned}
 +\Sigma M_B = 0; & \quad C_y(6) - 0.600(2) = 0 \quad C_y = 0.200 \text{ kip} \\
 +\uparrow \Sigma F_y = 0; & \quad B_y + 0.200 - 0.600 = 0 \quad B_y = 0.400 \text{ kip}
 \end{aligned}$$

From FBD (b),

$$\begin{aligned}
 (+\Sigma M_A = 0; & \quad M_A - 0.700(8) - 0.400(12) = 0 \\
 & \quad M_A = 10.4 \text{ kip}\cdot\text{ft} \\
 +\uparrow \Sigma F_y = 0; & \quad A_y - 0.700 - 0.400 = 0 \quad A_y = 1.10 \text{ kip}
 \end{aligned}$$

Shear and Moment Diagrams : The peak value of the moment for segment BC can be evaluated using the method of sections. The maximum moment occurs when $V = 0$. From FBD (c)

$$+\uparrow \Sigma F_y = 0; \quad 0.200 - \frac{1}{2}\left(\frac{x}{30}\right)x = 0 \quad x = 2\sqrt{3} \text{ ft}$$

$$\begin{aligned}
 (+\Sigma M = 0; & \quad 0.200x - \frac{1}{2}\left(\frac{x}{30}\right)x\left(\frac{x}{3}\right) - M = 0 \\
 & \quad M = 0.200x - \frac{x^3}{180}
 \end{aligned}$$

Thus,

$$(M_{\max})_{BC} = 0.200(2\sqrt{3}) - \frac{(2\sqrt{3})^3}{180} = 0.462 \text{ kip}\cdot\text{ft}$$

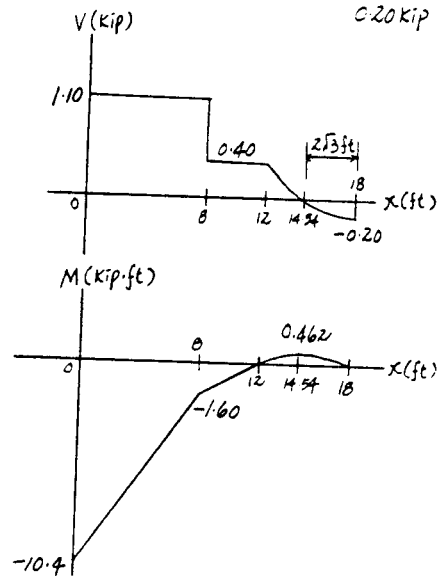
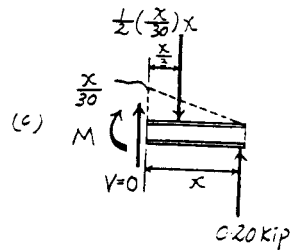
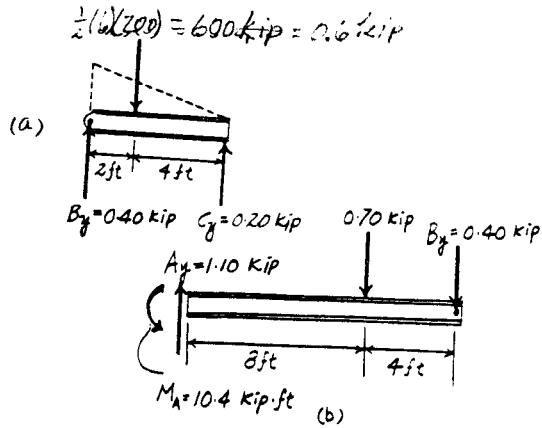

7-82. Draw the shear and moment diagrams for the beam.

Support Reactions : From FBD (a),

$$\begin{aligned} +\Sigma M_A = 0; & C_y(6) - 3.00(1) - 3.00(5) = 0 \quad C_y = 3.00 \text{ kN} \\ +\Sigma F_y = 0; & A_y + 3.00 - 3.00 - 3.00 = 0 \quad A_y = 3.00 \text{ kN} \end{aligned}$$

Shear and Moment Diagrams : The peak value of the moment diagram can be evaluated using the method of sections. The maximum moment occurs at the midspan ($x = 3 \text{ m}$) where $V = 0$. From FBD (b),

$$+\Sigma M = 0; \quad M - 3.00(1) = 0 \quad M = 3.00 \text{ kN}\cdot\text{m}$$

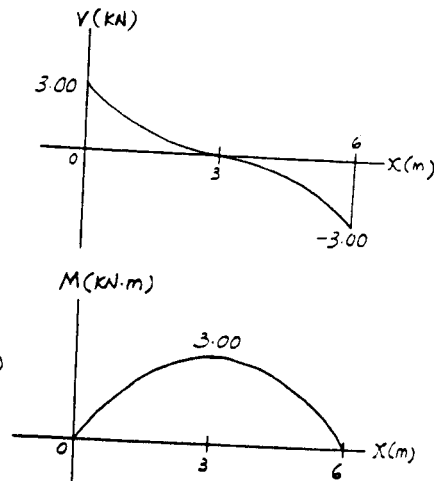
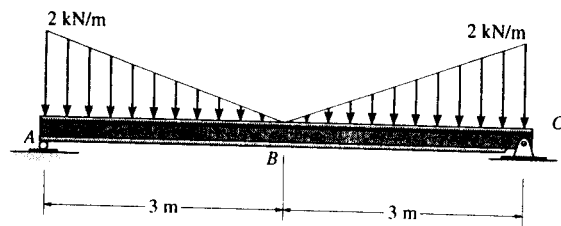
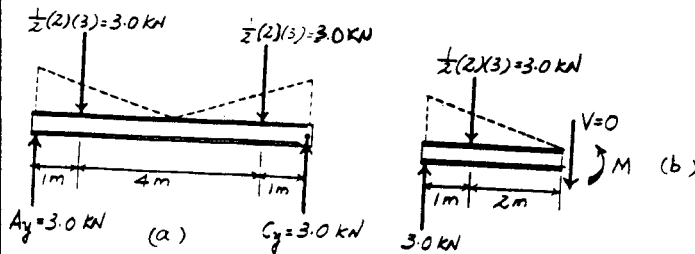

7-83. Draw the shear and moment diagrams for the beam.

Support Reactions :

$$\begin{aligned} +\Sigma M_A = 0; & B_y(L) - w_0L\left(\frac{L}{2}\right) - \frac{w_0L}{2}\left(\frac{4L}{3}\right) = 0 \\ & B_y = \frac{7w_0L}{6} \\ +\Sigma F_y = 0; & A_y + \frac{7w_0L}{6} - w_0L - \frac{w_0L}{2} = 0 \\ & A_y = \frac{w_0L}{3} \end{aligned}$$

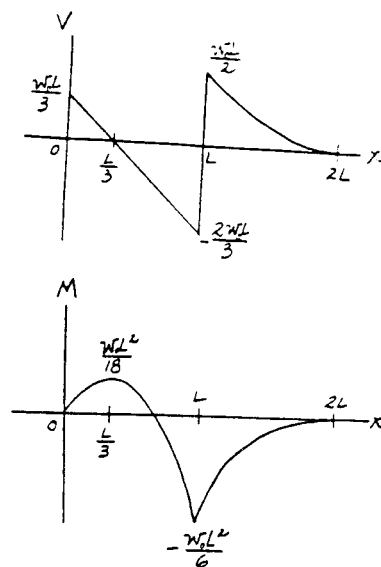
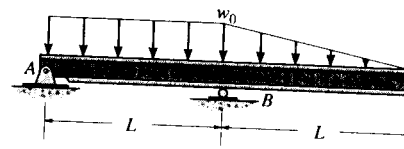
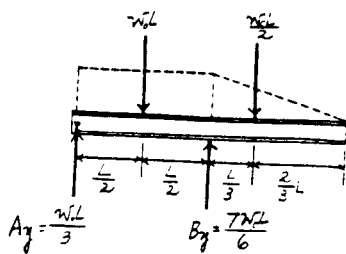

*7-84. Draw the shear and moment diagrams for the beam.

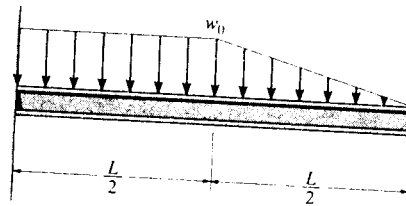

Support Reactions :

$$\begin{aligned} \sum M_A = 0; \quad M_A - \frac{w_0 L}{2} \left(\frac{L}{4} \right) - \frac{w_0 L}{4} \left(\frac{2L}{3} \right) &= 0 \\ M_A &= \frac{7w_0 L^2}{24} \end{aligned}$$

$$\sum F_y = 0; \quad A_y - \frac{w_0 L}{2} - \frac{w_0 L}{4} = 0 \quad A_y = \frac{3w_0 L}{4}$$

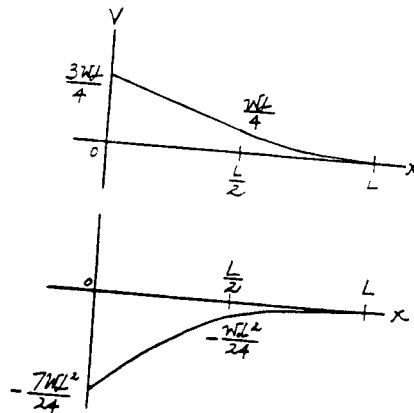
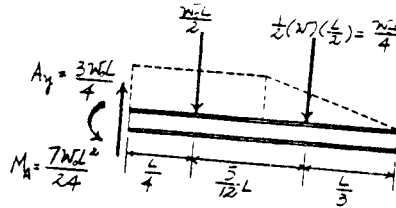

7-85. Draw the shear and moment diagrams for the beam.

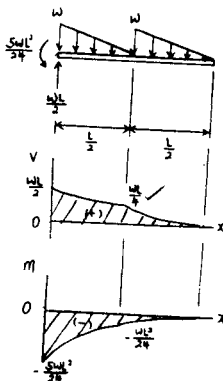
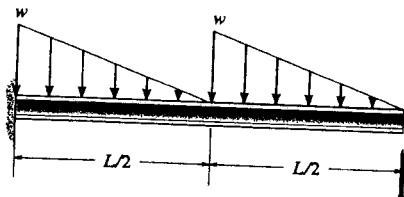

7-86. Draw the shear and moment diagrams for the beam.

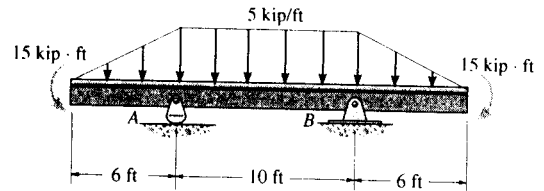

Support Reactions : From FBD (a),

$$\begin{aligned} +\Sigma M_A = 0; & \quad B_y(10) + 15.0(2) + 15 \\ & \quad - 50.0(5) - 15.0(12) - 15 = 0 \\ & \quad B_y = 40.0 \text{ kip} \\ +\uparrow \Sigma F_y = 0; & \quad A_y + 40.0 - 15.0 - 50.0 - 15.0 = 0 \\ & \quad A_y = 40.0 \text{ kip} \end{aligned}$$

Shear and Moment Diagrams : The value of the moment at supports A and B can be evaluated using the method of sections [FBD (c)].

$$+\Sigma M = 0; \quad M + 15.0(2) + 15 = 0 \quad M = -45.0 \text{ kip}\cdot\text{ft}$$

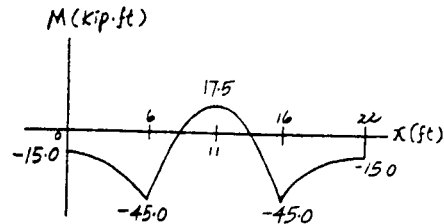
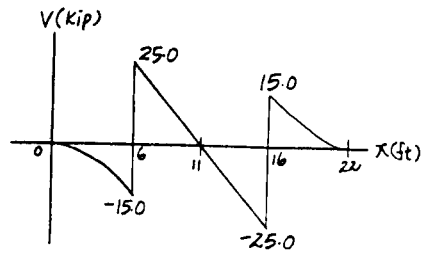
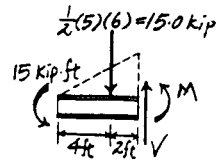
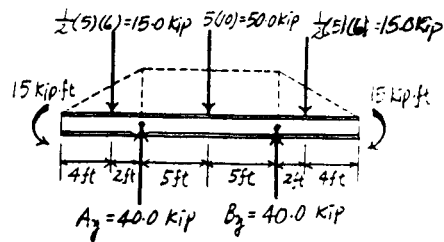

7-87. Draw the shear and moment diagrams for the beam.

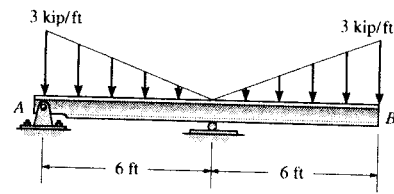

Support reactions: Shown on FBD (a)

From FBD (b)

$$+\uparrow \Sigma F_y = 0; \quad -V_6 - \frac{1}{2}(3)(6) = 0$$

$$V_6 = -9 \text{ kip}$$

$$\Sigma M = 0; \quad M_6 + \frac{1}{2}(3)(6)(4) = 0$$

$$M_6 = -36 \text{ kip}\cdot\text{ft}$$

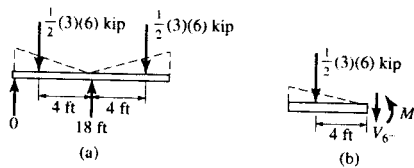
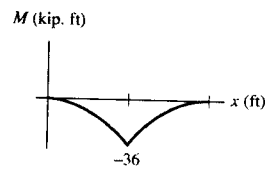
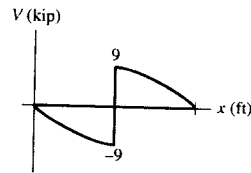

*7-88. Draw the shear and moment diagrams for the beam.

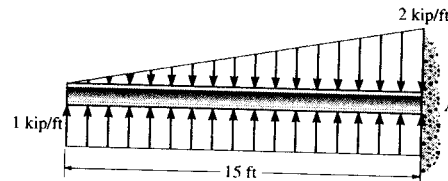

Shear and Moment Functions: For $0 \leq x < 15$ ft

$$+\uparrow \Sigma F_y = 0; \quad 1x - x^2/15 - V = 0$$

$$V = \{x - x^2/15\} \text{ N} \quad \text{Ans}$$

$$\curvearrowleft + \Sigma M = 0; \quad M + (x^2/15)\left(\frac{x}{3}\right) - 1x(x/2) = 0$$

$$M = \{x^2/2 - x^3/45\} \text{ N}\cdot\text{m} \quad \text{Ans}$$

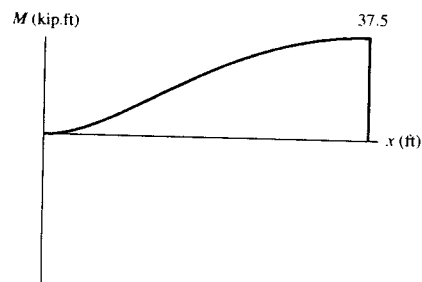
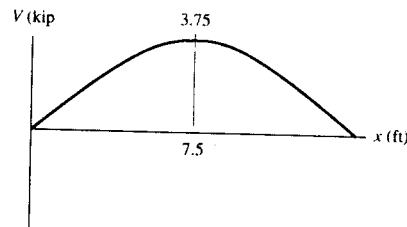

*7-89. Determine the tension in each segment of the cable and the cable's total length.

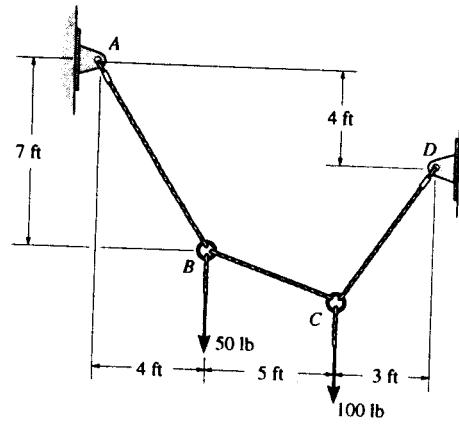

Equations of Equilibrium : Applying method of joints, we have

Joint B

$$\rightarrow \Sigma F_x = 0; \quad F_{BC} \cos \theta - F_{BA} \left(\frac{4}{\sqrt{65}} \right) = 0 \quad [1]$$

$$+ \uparrow \Sigma F_y = 0; \quad F_{BA} \left(\frac{7}{\sqrt{65}} \right) - F_{BC} \sin \theta - 50 = 0 \quad [2]$$

Joint C

$$\rightarrow \Sigma F_x = 0; \quad F_{CD} \cos \phi - F_{BC} \cos \theta = 0 \quad [3]$$

$$+ \uparrow \Sigma F_y = 0; \quad F_{BC} \sin \theta + F_{CD} \sin \phi - 100 = 0 \quad [4]$$

Geometry :

$$\sin \theta = \frac{y}{\sqrt{y^2 + 25}} \quad \cos \theta = \frac{5}{\sqrt{y^2 + 25}}$$

$$\sin \phi = \frac{3+y}{\sqrt{y^2 + 6y + 18}} \quad \cos \phi = \frac{3}{\sqrt{y^2 + 6y + 18}}$$

Substitute the above results into Eqs. [1], [2], [3] and [4] and solve. We have

$$F_{BC} = 46.7 \text{ lb} \quad F_{BA} = 83.0 \text{ lb} \quad F_{CD} = 88.1 \text{ lb} \quad \text{Ans}$$

$$y = 2.679 \text{ ft}$$

The total length of the cable is

$$l = \sqrt{7^2 + 4^2} + \sqrt{5^2 + 2.679^2} + \sqrt{3^2 + (2.679 + 3)^2}$$

$$= 20.2 \text{ ft}$$

Ans

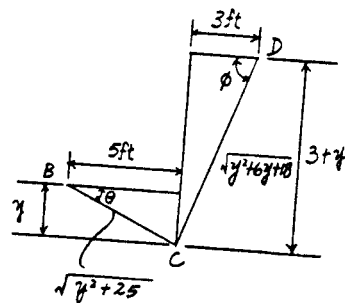
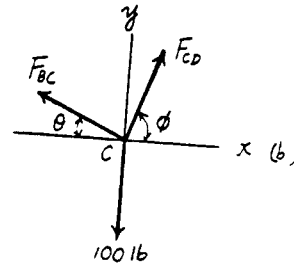
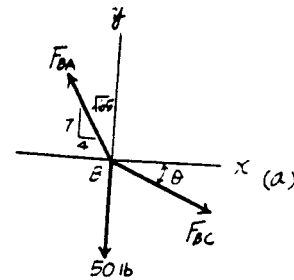

7-90. Determine the tension in each segment of the cable and the cable's total length.

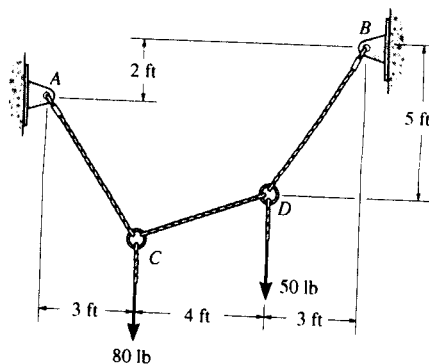

Equations of Equilibrium: Applying method of joints, we have

Joint D

$$\rightarrow \Sigma F_x = 0; \quad F_{DB} \left(\frac{3}{\sqrt{34}} \right) - F_{DC} \cos \theta = 0 \quad [1]$$

$$+ \uparrow \Sigma F_y = 0; \quad F_{DB} \left(\frac{5}{\sqrt{34}} \right) - F_{DC} \sin \theta - 50 = 0 \quad [2]$$

Joint C

$$\rightarrow \Sigma F_x = 0; \quad F_{DC} \cos \theta - F_{CA} \cos \phi = 0 \quad [3]$$

$$+ \uparrow \Sigma F_y = 0; \quad F_{DC} \sin \theta + F_{CA} \sin \phi - 80 = 0 \quad [4]$$

Geometry:

$$\sin \theta = \frac{y}{\sqrt{y^2 + 16}} \quad \cos \theta = \frac{4}{\sqrt{y^2 + 16}}$$

$$\sin \phi = \frac{y + 3}{\sqrt{y^2 + 6y + 18}} \quad \cos \phi = \frac{3}{\sqrt{y^2 + 6y + 18}}$$

Substitute the above results into Eqs. [1], [2], [3] and [4] and solve. We have

$$F_{DC} = 43.7 \text{ lb} \quad F_{DB} = 78.2 \text{ lb} \quad F_{CA} = 74.7 \text{ lb} \quad \text{Ans}$$

$$y = 1.695 \text{ ft}$$

The total length of the cable is

$$l = \sqrt{5^2 + 3^2} + \sqrt{4^2 + 1.695^2} + \sqrt{3^2 + (1.695 + 3)^2}$$

$$= 15.7 \text{ ft} \quad \text{Ans}$$

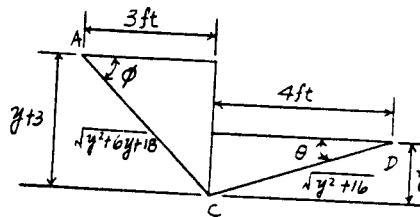
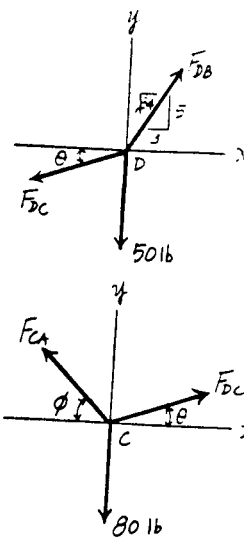

7-91. The cable supports the three loads shown. Determine the sags y_B and y_D of points B and D . Take $P_1 = 400$ lb, $P_2 = 250$ lb.

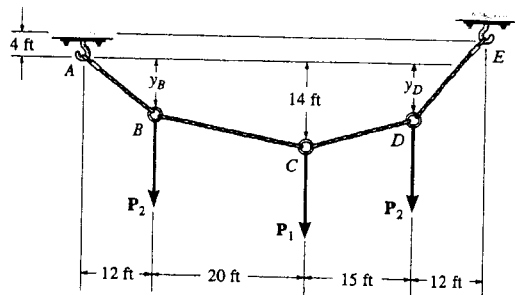

At B

$$\rightarrow \Sigma F_x = 0; \quad \frac{20}{\sqrt{(14-y_B)^2 + 400}} T_{BC} - \frac{12}{\sqrt{y_B^2 + 144}} T_{AB} = 0$$

$$+\uparrow \Sigma F_y = 0; \quad -\frac{14-y_B}{\sqrt{(14-y_B)^2 + 400}} T_{BC} + \frac{y_B}{\sqrt{y_B^2 + 144}} T_{AB} - 250 = 0$$

$$\frac{32y_B - 168}{\sqrt{(14-y_B)^2 + 400}} T_{BC} = 3000 \quad (1)$$

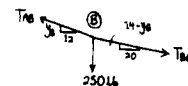

At C

$$\rightarrow \Sigma F_x = 0; \quad \frac{15}{\sqrt{(14-y_D)^2 + 225}} T_{CD} - \frac{20}{\sqrt{(14-y_B)^2 + 400}} T_{BC} = 0$$

$$+\uparrow \Sigma F_y = 0; \quad \frac{14-y_D}{\sqrt{(14-y_D)^2 + 225}} T_{CD} + \frac{14-y_B}{\sqrt{(14-y_B)^2 + 400}} T_{BC} - 400 = 0$$

$$\frac{-20y_D + 490 - 15y_B}{\sqrt{(14-y_D)^2 + 400}} T_{BC} = 6000 \quad (2)$$

$$\frac{-20y_D + 490 - 15y_B}{\sqrt{(14-y_D)^2 + 225}} T_{CD} = 8000 \quad (3)$$

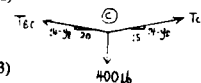

At D

$$\rightarrow \Sigma F_x = 0; \quad \frac{12}{\sqrt{(4+y_D)^2 + 144}} T_{DE} - \frac{15}{\sqrt{(14-y_D)^2 + 225}} T_{CD} = 0$$

$$+\uparrow \Sigma F_y = 0; \quad \frac{4+y_D}{\sqrt{(4+y_D)^2 + 144}} T_{DE} - \frac{14-y_D}{\sqrt{(14-y_D)^2 + 225}} T_{CD} - 250 = 0$$

$$\frac{-108 + 27y_D}{\sqrt{(14-y_D)^2 + 225}} T_{CD} = 3000 \quad (4)$$

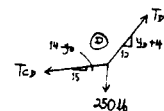

Combining Eqs. (1) & (2)

$$79y_B + 20y_D = 826$$

Combining Eqs. (3) & (4)

$$45y_B + 276y_D = 2334$$

$$y_B = 8.67 \text{ ft} \quad \text{Ans}$$

$$y_D = 7.04 \text{ ft} \quad \text{Ans}$$

*7-92. The cable supports the three loads shown. Determine the magnitude of P_1 if $P_2 = 300$ lb and $y_B = 8$ ft. Also find the sag y_D .

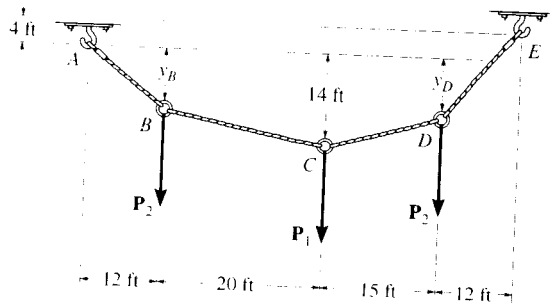

At B

$$\rightarrow \Sigma F_x = 0; \quad \frac{20}{\sqrt{436}} T_{BC} - \frac{12}{\sqrt{208}} T_{AB} = 0$$

$$+ \uparrow \Sigma F_y = 0; \quad \frac{-6}{\sqrt{436}} T_{BC} + \frac{8}{\sqrt{208}} T_{AB} - 300 = 0$$

$$T_{AB} = 983.3 \text{ lb}$$

$$T_{BC} = 854.2 \text{ lb}$$

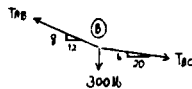

At C

$$\rightarrow \Sigma F_x = 0; \quad \frac{-20}{\sqrt{436}} (854.2) + \frac{15}{\sqrt{(14-y_D)^2 + 225}} T_{CD} = 0 \quad (1)$$

$$+ \uparrow \Sigma F_y = 0; \quad \frac{6}{\sqrt{436}} (854.2) + \frac{14-y_D}{\sqrt{(14-y_D)^2 + 225}} T_{CD} - P_1 = 0 \quad (2)$$

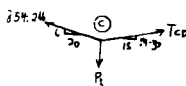

At D

$$\rightarrow \Sigma F_x = 0; \quad \frac{12}{\sqrt{(4+y_D)^2 + 144}} T_{DE} - \frac{15}{\sqrt{(14-y_D)^2 + 225}} T_{CD} = 0$$

$$+ \uparrow \Sigma F_y = 0; \quad \frac{4+y_D}{\sqrt{(4+y_D)^2 + 144}} T_{DE} - \frac{14-y_D}{\sqrt{(14-y_D)^2 + 225}} T_{CD} - 300 = 0$$

$$T_{CD} = \frac{3600\sqrt{225 + (14-y_D)^2}}{27y_D - 108}$$

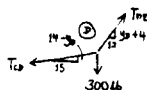

Substitute into Eq. (1):

$$y_D = 6.44 \text{ ft} \quad \text{Ans}$$

$$T_{CD} = 916.1 \text{ lb}$$

$$P_1 = 658 \text{ lb} \quad \text{Ans}$$

7-93. The cable supports the loading shown. Determine the distance x_B the force at point B acts from A. Set $P = 40$ lb.

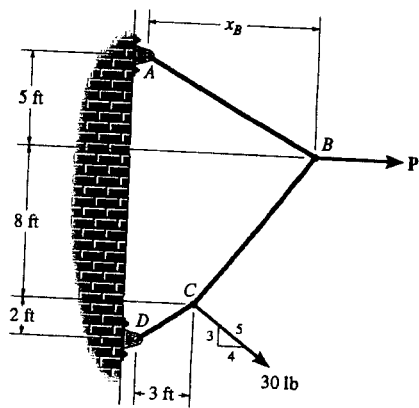

At B

$$\begin{aligned} \rightarrow \Sigma F_x = 0; & \quad 40 - \frac{x_B}{\sqrt{x_B^2 + 25}} T_{AB} - \frac{x_B - 3}{\sqrt{(x_B - 3)^2 + 64}} T_{BC} = 0 \\ + \uparrow \Sigma F_y = 0; & \quad \frac{5}{\sqrt{x_B^2 + 25}} T_{AB} - \frac{8}{\sqrt{(x_B - 3)^2 + 64}} T_{BC} = 0 \\ & \quad \frac{13x_B - 15}{\sqrt{(x_B - 3)^2 + 64}} T_{BC} = 200 \quad (1) \end{aligned}$$

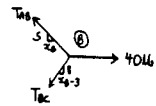

At C

$$\begin{aligned} \rightarrow \Sigma F_x = 0; & \quad \frac{4}{5}(30) + \frac{x_B - 3}{\sqrt{(x_B - 3)^2 + 64}} T_{BC} - \frac{3}{\sqrt{13}} T_{CD} = 0 \\ + \uparrow \Sigma F_y = 0; & \quad \frac{8}{\sqrt{(x_B - 3)^2 + 64}} T_{BC} - \frac{2}{\sqrt{13}} T_{CD} - \frac{3}{5}(30) = 0 \\ & \quad \frac{30 - 2x_B}{\sqrt{(x_B - 3)^2 + 64}} T_{BC} = 102 \quad (2) \end{aligned}$$

Solving Eqs. (1) & (2)

$$\begin{aligned} \frac{13x_B - 15}{30 - 2x_B} &= \frac{200}{102} \\ x_B &= 4.36 \text{ ft} \quad \text{Ans} \end{aligned}$$

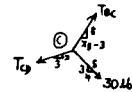

7-94. The cable supports the loading shown. Determine the magnitude of the horizontal force P so that $x_B = 6$ ft.

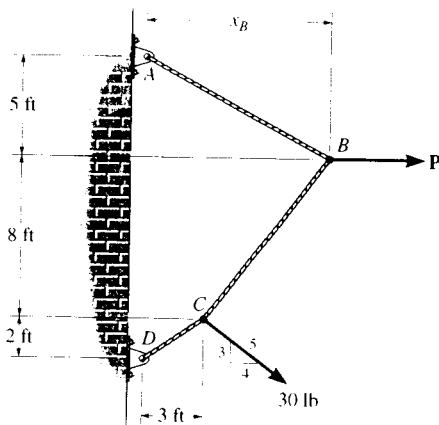

At B

$$\begin{aligned} \rightarrow \Sigma F_x = 0; & \quad P - \frac{6}{\sqrt{61}} T_{AB} - \frac{3}{\sqrt{73}} T_{BC} = 0 \\ + \uparrow \Sigma F_y = 0; & \quad \frac{5}{\sqrt{61}} T_{AB} - \frac{8}{\sqrt{73}} T_{BC} = 0 \\ & \quad 5P - \frac{63}{\sqrt{73}} T_{BC} = 0 \quad (1) \end{aligned}$$

At C

$$\begin{aligned} \rightarrow \Sigma F_x = 0; & \quad \frac{4}{5}(30) + \frac{3}{\sqrt{73}} T_{BC} - \frac{3}{\sqrt{13}} T_{CD} = 0 \\ + \uparrow \Sigma F_y = 0; & \quad \frac{8}{\sqrt{73}} T_{BC} - \frac{2}{\sqrt{13}} T_{CD} - \frac{3}{5}(30) = 0 \\ & \quad \frac{18}{\sqrt{73}} T_{BC} = 102 \quad (2) \end{aligned}$$

Solving Eqs. (1) & (2)

$$\begin{aligned} \frac{63}{18} &= \frac{5P}{102} \\ P &= 71.4 \text{ lb} \quad \text{Ans} \end{aligned}$$

7-95. Determine the forces P_1 and P_2 needed to hold the cable in the position shown, i.e., so segment CD remains horizontal. Also, find the maximum tension in the cable.

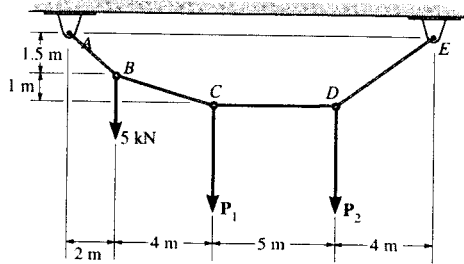

Method of Joints:

Joint B

$$\rightarrow \Sigma F_x = 0; \quad F_{BC} \left(\frac{4}{\sqrt{17}} \right) - F_{AB} \left(\frac{2}{2.5} \right) = 0 \quad [1]$$

$$+ \uparrow \Sigma F_y = 0; \quad F_{AB} \left(\frac{1.5}{2.5} \right) - F_{BC} \left(\frac{1}{\sqrt{17}} \right) - 5 = 0 \quad [2]$$

Solving Eqs. [1] and [2] yields

$$F_{BC} = 10.31 \text{ kN} \quad F_{AB} = 12.5 \text{ kN}$$

Joint C

$$\rightarrow \Sigma F_x = 0; \quad F_{CD} - 10.31 \left(\frac{4}{\sqrt{17}} \right) = 0 \quad F_{CD} = 10.0 \text{ kN}$$

$$+ \uparrow \Sigma F_y = 0; \quad 10.31 \left(\frac{1}{\sqrt{17}} \right) - P_1 = 0 \quad P_1 = 2.50 \text{ kN} \quad \text{Ans}$$

Joint D

$$\rightarrow \Sigma F_x = 0; \quad F_{DE} \left(\frac{4}{\sqrt{22.25}} \right) - 10 = 0 \quad [1]$$

$$+ \uparrow \Sigma F_y = 0; \quad F_{DE} \left(\frac{P_2}{\sqrt{22.25}} \right) - 2.5 = 0 \quad [2]$$

Solving Eqs. [1] and [2] yields

$$P_2 = 6.25 \text{ kN} \quad \text{Ans}$$

$$F_{DE} = 11.79 \text{ kN}$$

Thus, the maximum tension in the cable is

$$F_{\max} = F_{AB} = 12.5 \text{ kN} \quad \text{Ans}$$

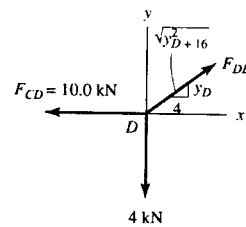
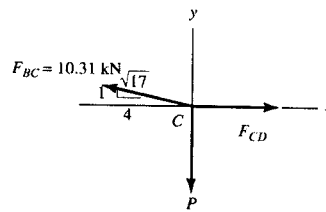
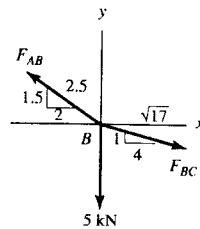

*7-96. The cable supports the three loads shown. Determine the sags y_B and y_D of points B and D and the tension in each segment of the cable.

Equations of Equilibrium: From FBD (a),

$$\begin{aligned} \left(+\Sigma M_E = 0; \right. & -F_{AB} \left(\frac{y_B}{\sqrt{y_B^2 + 144}} \right) (47) - F_{AB} \left(\frac{12}{\sqrt{y_B^2 + 144}} \right) (y_B + 4) \\ & + 200(12) + 500(27) + 300(47) = 0 \\ & F_{AB} \left(\frac{47y_B}{\sqrt{y_B^2 + 144}} \right) + F_{AB} \left(\frac{12(y_B + 4)}{\sqrt{y_B^2 + 144}} \right) = 30000 \end{aligned} \quad [1]$$

From FBD (b),

$$\begin{aligned} \left(+\Sigma M_C = 0; \right. & -F_{AB} \left(\frac{y_B}{\sqrt{y_B^2 + 144}} \right) (20) + F_{AB} \left(\frac{12}{\sqrt{y_B^2 + 144}} \right) (14 - y_B) \\ & + 300(20) = 0 \\ & F_{AB} \left(\frac{20y_B}{\sqrt{y_B^2 + 144}} \right) - F_{AB} \left(\frac{12(14 - y_B)}{\sqrt{y_B^2 + 144}} \right) = 6000 \end{aligned} \quad [2]$$

Solving Eqs. [1] and [2] yields

$$y_B = 8.792 \text{ ft} = 8.79 \text{ ft} \quad F_{AB} = 787.47 \text{ lb} = 787 \text{ lb} \quad \text{Ans}$$

Method of Joints:

Joint B

$$\begin{aligned} \rightarrow \Sigma F_x = 0; & F_{BC} \cos 14.60^\circ - 787.47 \cos 36.23^\circ = 0 \\ & F_{BC} = 656.40 \text{ lb} = 656 \text{ lb} \quad \text{Ans} \end{aligned}$$

$$\begin{aligned} + \uparrow \Sigma F_y = 0; & 787.47 \sin 36.23^\circ \\ & - 656.40 \sin 14.60^\circ - 300 = 0 \quad (\text{Checks!}) \end{aligned}$$

Joint C

$$\begin{aligned} \rightarrow \Sigma F_x = 0; & F_{CD} \left(\frac{15}{\sqrt{y_D^2 - 28y_D + 421}} \right) - 656.40 \cos 14.60^\circ = 0 \end{aligned} \quad [3]$$

$$\begin{aligned} + \uparrow \Sigma F_y = 0; & F_{CD} \left(\frac{14 - y_D}{\sqrt{y_D^2 - 28y_D + 421}} \right) \\ & + 656.40 \sin 14.60^\circ - 500 = 0 \end{aligned} \quad [4]$$

Solving Eqs. [1] and [2] yields

$$y_D = 6.099 \text{ ft} = 6.10 \text{ ft} \quad F_{CD} = 717.95 \text{ lb} = 718 \text{ lb} \quad \text{Ans}$$

Joint D

$$\begin{aligned} \rightarrow \Sigma F_x = 0; & F_{DE} \cos 40.08^\circ - 717.95 \cos 27.78^\circ = 0 \\ & F_{DE} = 830.24 \text{ lb} = 830 \text{ lb} \quad \text{Ans} \end{aligned}$$

$$\begin{aligned} + \uparrow \Sigma F_y = 0; & 830.24 \sin 40.08^\circ \\ & - 717.95 \sin 27.78^\circ - 200 = 0 \quad (\text{Checks!}) \end{aligned}$$

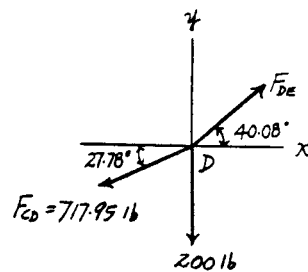
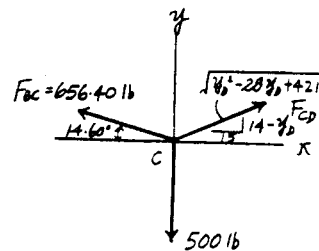
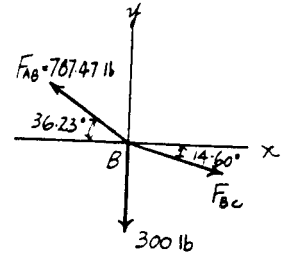
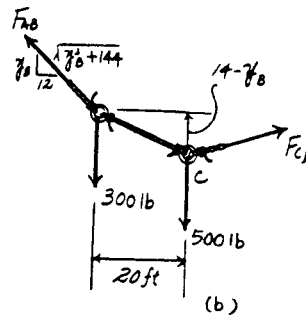
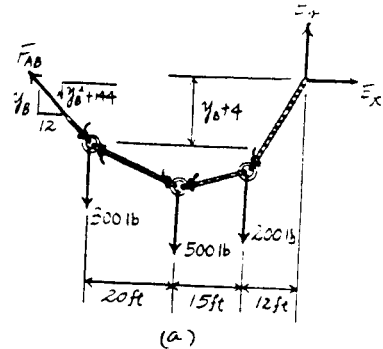
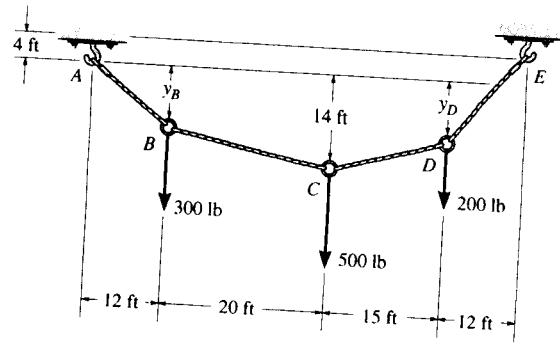

7-97. Determine the maximum uniform loading w , measured in lb/ft, that the cable can support if it is capable of sustaining a maximum tension of 3000 lb before it will break.

$$y = \frac{1}{F_H} \int \left(\int w dx \right) dx$$

$$\text{At } x = 0, \quad \frac{dy}{dx} = 0$$

$$\text{At } x = 0, \quad y = 0$$

$$C_1 = C_2 = 0$$

$$y = \frac{w}{2F_H} x^2$$

$$\text{At } x = 25 \text{ ft}, \quad y = 6 \text{ ft} \quad F_H = 52.08 w$$

$$\left. \frac{dy}{dx} \right|_{x=25} = \tan \theta_{\max} = \left. \frac{w}{F_H} x \right|_{x=25}$$

$$\theta_{\max} = \tan^{-1}(0.48) = 25.64^\circ$$

$$T_{\max} = \frac{F_H}{\cos \theta_{\max}} = 3000$$

$$F_H = 2705 \text{ lb}$$

$$w = 51.9 \text{ lb/ft} \quad \text{Ans}$$

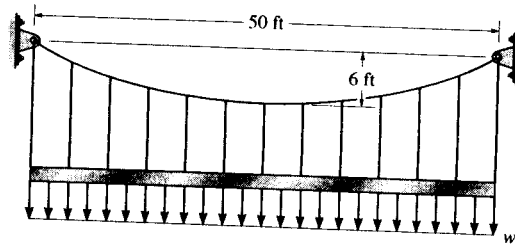
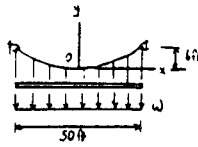

7-98. The cable is subjected to a uniform loading of $w = 250$ lb/ft. Determine the maximum and minimum tension in the cable.

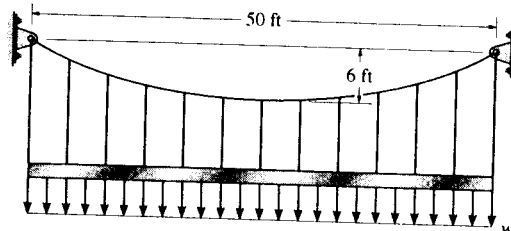

From Example 7-14;

$$F_H = \frac{w_0 L^2}{8h} = \frac{250(50)^2}{8(6)} = 13\,021 \text{ lb}$$

$$\theta_{\max} = \tan^{-1} \left(\frac{w_0 L}{2F_H} \right) = \tan^{-1} \left(\frac{250(50)}{2(13\,021)} \right) = 25.64^\circ$$

$$T_{\max} = \frac{F_H}{\cos \theta_{\max}} = \frac{13\,021}{\cos 25.64^\circ} = 14.4 \text{ kip} \quad \text{Ans}$$

The minimum tension occurs at $\theta = 0^\circ$.

$$T_{\min} = F_H = 13.0 \text{ kip} \quad \text{Ans}$$

7-99. The cable AB is subjected to a uniform loading of 200 N/m . If the weight of the cable is neglected and the slope angles at points A and B are 30° and 60° , respectively, determine the curve that defines the cable shape and the maximum tension developed in the cable.

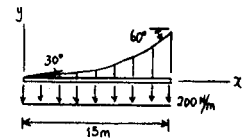
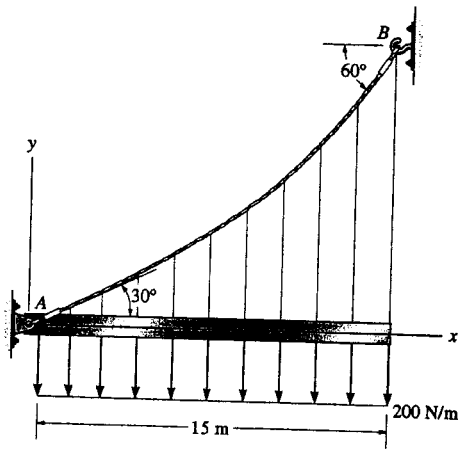

$$y = \frac{1}{F_H} \int (\int 200 \, dx) \, dx$$

$$y = \frac{1}{F_H} (100x^2 + C_1x + C_2)$$

$$\frac{dy}{dx} = \frac{1}{F_H} (200x + C_1)$$

$$\text{At } x = 0, \quad y = 0; \quad C_2 = 0$$

$$\text{At } x = 0, \quad \frac{dy}{dx} = \tan 30^\circ; \quad C_1 = F_H \tan 30^\circ$$

$$y = \frac{1}{F_H} (100x^2 + F_H \tan 30^\circ x)$$

$$\text{At } x = 15 \text{ m}, \quad \frac{dy}{dx} = \tan 60^\circ; \quad F_H = 2598 \text{ N}$$

$$y = (38.5x^2 + 577x)(10^{-3}) \text{ m} \quad \text{Ans}$$

$$\theta_{max} = 60^\circ$$

$$T_{max} = \frac{F_H}{\cos \theta_{max}} = \frac{2598}{\cos 60^\circ} = 5196 \text{ N}$$

$$T_{max} = 5.20 \text{ kN} \quad \text{Ans}$$

*7-100. The cable supports a girder which weighs 850 lb/ft. Determine the tension in the cable at points A, B, and C.

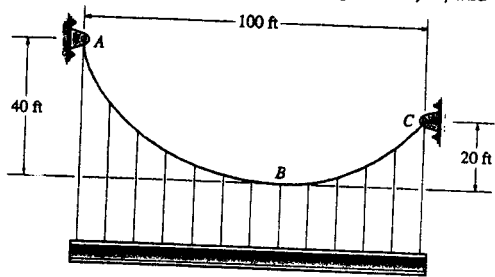

$$y = \frac{1}{F_H} \int (\int w_0 dx) dx$$

$$y = \frac{1}{F_H} (425x^2 + C_1x + C_2)$$

$$\frac{dy}{dx} = \frac{850}{F_H}x + \frac{C_1}{F_H}$$

$$\text{At } x = 0, \quad \frac{dy}{dx} = 0 \quad C_1 = 0$$

$$\text{At } x = 0, \quad y = 0 \quad C_2 = 0$$

$$y = \frac{425}{F_H}x^2$$

$$\text{At } y = 20 \text{ ft}, \quad x = x'$$

$$20 = \frac{425(x')^2}{F_H}$$

$$\text{At } y = 40 \text{ ft}, \quad x = (100 - x')$$

$$40 = \frac{425(100 - x')^2}{F_H}$$

$$2(x')^2 = (x')^2 - 200x' + 100^2$$

$$(x')^2 + 200x' - 100^2 = 0$$

$$x' = \frac{-200 \pm \sqrt{200^2 + 4(100)^2}}{2} = 41.42 \text{ ft}$$

$$F_H = 36\,459 \text{ lb}$$

At A,

$$\frac{dy}{dx} = \tan \theta_A = \left. \frac{2(425)x}{F_H} \right|_{x=38.58 \text{ ft}} = 1.366$$

$$\theta_A = 53.79^\circ$$

$$T_A = \frac{F_H}{\cos \theta_A} = \frac{36\,459}{\cos 53.79^\circ} = 61\,714 \text{ lb}$$

$$T_A = 61.7 \text{ kip} \quad \text{Ans}$$

At B,

$$T_B = F_H = 36.5 \text{ kip} \quad \text{Ans}$$

At C,

$$\frac{dy}{dx} = \tan \theta_C = \left. \frac{2(425)x}{F_H} \right|_{x=41.42 \text{ ft}} = 0.9657$$

$$\theta_C = 44.0^\circ$$

$$T_C = \frac{F_H}{\cos \theta_C} = \frac{36\,459}{\cos 44.0^\circ} = 50\,683 \text{ lb}$$

$$T_C = 50.7 \text{ kip} \quad \text{Ans}$$

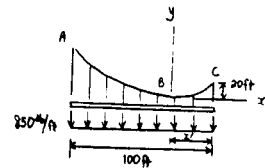

7-10L. The cable is subjected to the triangular loading. If the slope of the cable at point O is zero, determine the equation of the curve $y = f(x)$ which defines the cable shape OB , and the maximum tension developed in the cable.

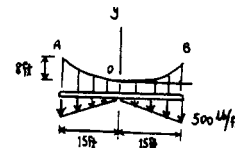
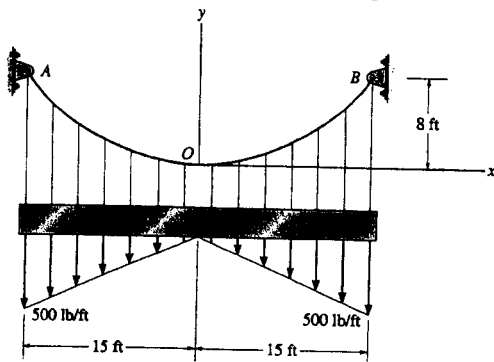

$$\begin{aligned}
 y &= \frac{1}{F_H} \int (\int w(x) dx) dx \\
 &= \frac{1}{F_H} \int (\int \frac{500}{15} x dx) dx \\
 &= \frac{1}{F_H} \int (\frac{50}{3} x^2 + C_1) dx \\
 &= \frac{1}{F_H} (\frac{50}{9} x^3 + C_1 x + C_2)
 \end{aligned}$$

$$\frac{dy}{dx} = \frac{50}{3F_H} x^2 + \frac{C_1}{F_H}$$

At $x = 0$, $\frac{dy}{dx} = 0$ $C_1 = 0$

At $x = 0$, $y = 0$ $C_2 = 0$

$$y = \frac{50}{9F_H} x^3$$

At $x = 15$ ft, $y = 8$ ft $F_H = 2344$ lb

$$y = 2.37(10^{-3})x^3 \quad \text{Ans}$$

$$\left. \frac{dy}{dx} \right|_{x=15} = \tan \theta_{max} = \left. \frac{50}{3(2344)} x^2 \right|_{x=15}$$

$$\theta_{max} = \tan^{-1}(1.6) = 57.99^\circ$$

$$T_{max} = \frac{F_H}{\cos \theta_{max}} = \frac{2344}{\cos 57.99^\circ} = 4422 \text{ lb}$$

$$T_{max} = 4.42 \text{ kip} \quad \text{Ans}$$

7-102. The cable is subjected to the parabolic loading $w = 150(1 - (x/50)^2)$ lb/ft, where x is in ft. Determine the equation $y = f(x)$ which defines the cable shape AB and the maximum tension in the cable.

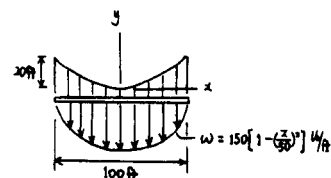
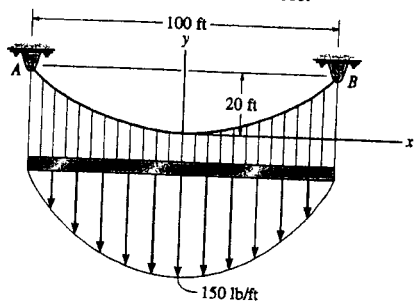

$$y = \frac{1}{F_H} \int (\int w(x) dx) dx$$

$$y = \frac{1}{F_H} \int [150x - \frac{x^3}{3(50)^2}] + C_1 dx$$

$$y = \frac{1}{F_H} (75x^2 - \frac{x^4}{200} + C_1x + C_2)$$

$$\frac{dy}{dx} = \frac{150x}{F_H} - \frac{1}{50F_H} x^3 + \frac{C_1}{F_H}$$

$$\text{At } x = 0, \quad \frac{dy}{dx} = 0 \quad C_1 = 0$$

$$\text{At } x = 0, \quad y = 0 \quad C_2 = 0$$

$$y = \frac{1}{F_H} (75x^2 - \frac{x^4}{200})$$

$$\text{At } x = 50 \text{ ft}, \quad y = 20 \text{ ft} \quad F_H = 7813 \text{ lb}$$

$$y = \frac{x^2}{7813} (75 - \frac{x^2}{200}) \text{ ft} \quad \text{Ans}$$

$$\frac{dy}{dx} = \frac{1}{7813} (150x - \frac{4x^3}{200}) \Big|_{x=50 \text{ ft}} = \tan \theta_{max}$$

$$\theta_{max} = 32.62^\circ$$

$$T_{max} = \frac{F_H}{\cos \theta_{max}} = \frac{7813}{\cos 32.62^\circ} = 9275.9 \text{ lb}$$

$$T_{max} = 9.28 \text{ kip} \quad \text{Ans}$$

7-103. The cable will break when the maximum tension reaches $T_{\max} = 10\text{kN}$. Determine the sag h if it supports the uniform distributed load of $w = 600\text{ N/m}$.

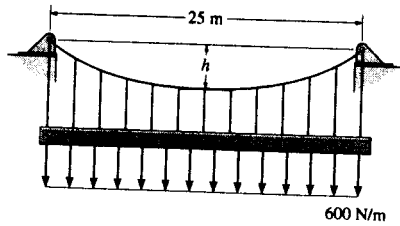

The Equation of The Cable :

$$y = \frac{1}{F_H} \int (\int w(x) dx) dx$$

$$= \frac{1}{F_H} \left(\frac{w_0}{2} x^2 + C_1 x + C_2 \right) \quad [1]$$

$$\frac{dy}{dx} = \frac{1}{F_H} (w_0 x + C_1) \quad [2]$$

Boundary Conditions :

$$y = 0 \text{ at } x = 0, \text{ then from Eq.[1]} \quad 0 = \frac{1}{F_H} (C_2) \quad C_2 = 0$$

$$\frac{dy}{dx} = 0 \text{ at } x = 0, \text{ then from Eq.[2]} \quad 0 = \frac{1}{F_H} (C_1) \quad C_1 = 0$$

$$\text{Thus,} \quad y = \frac{w_0}{2F_H} x^2 \quad [3]$$

$$\frac{dy}{dx} = \frac{w_0}{F_H} x \quad [4]$$

$$y = h \text{ at } x = 12.5 \text{ m, then from Eq.[3]} \quad h = \frac{w_0}{2F_H} (12.5^2) \quad F_H = \frac{78.125}{h} w_0$$

$\theta = \theta_{\max}$ at $x = 12.5$ m and the maximum tension occurs when $\theta = \theta_{\max}$. From Eq.[4]

$$\tan \theta_{\max} = \left. \frac{dy}{dx} \right|_{x=12.5 \text{ m}} = \frac{w_0}{F_H} x = \frac{78.125}{h} w_0 x = 0.0128h(12.5) = 0.160h$$

$$\text{Thus,} \quad \cos \theta_{\max} = \frac{1}{\sqrt{0.0256h^2 + 1}}$$

The maximum tension in the cable is

$$T_{\max} = \frac{F_H}{\cos \theta_{\max}}$$

$$10 = \frac{\frac{78.125}{h} (0.6)}{\frac{1}{\sqrt{0.0256h^2 + 1}}}$$

$$h = 7.09 \text{ m} \quad \text{Ans}$$

*7-104. Determine the maximum tension developed in the cable if it is subjected to a uniform load of 600 N/m.

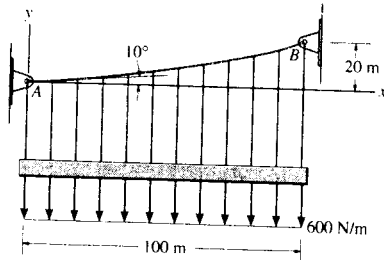

The Equation of The Cable :

$$y = \frac{1}{F_H} \int (\int w(x) dx) dx$$

$$= \frac{1}{F_H} \left(\frac{w_0}{2} x^2 + C_1 x + C_2 \right) \quad [1]$$

$$\frac{dy}{dx} = \frac{1}{F_H} (w_0 x + C_1) \quad [2]$$

Boundary Conditions :

$$y = 0 \text{ at } x = 0, \text{ then from Eq.[1]} \quad 0 = \frac{1}{F_H} (C_2) \quad C_2 = 0$$

$$\frac{dy}{dx} = \tan 10^\circ \text{ at } x = 0, \text{ then from Eq.[2]} \quad \tan 10^\circ = \frac{1}{F_H} (C_1) \quad C_1 = F_H \tan 10^\circ$$

$$\text{Thus,} \quad y = \frac{w_0}{2F_H} x^2 + \tan 10^\circ x \quad [3]$$

$y = 20 \text{ m}$ at $x = 100 \text{ m}$, then from Eq.[3]

$$20 = \frac{600}{2F_H} (100^2) + \tan 10^\circ (100) \quad F_H = 1\,267\,265.47 \text{ N}$$

and

$$\frac{dy}{dx} = \frac{w_0}{F_H} x + \tan 10^\circ$$

$$= \frac{600}{1\,267\,265.47} x + \tan 10^\circ$$

$$= 0.4735 (10^{-3}) x + \tan 10^\circ$$

$\theta = \theta_{\max}$ at $x = 100 \text{ m}$ and the maximum tension occurs when $\theta = \theta_{\max}$.

$$\tan \theta_{\max} = \left. \frac{dy}{dx} \right|_{x=100 \text{ m}} = 0.4735 (10^{-3}) (100) + \tan 10^\circ$$

$$\theta_{\max} = 12.61^\circ$$

The maximum tension in the cable is

$$T_{\max} = \frac{F_H}{\cos \theta_{\max}} = \frac{1\,267\,265.47}{\cos 12.61^\circ} = 1\,298\,579.00 \text{ N} = 1.30 \text{ MN} \quad \text{Ans}$$

■ 7-105. A cable has a weight of 5 lb/ft. If it can span 300 ft and has a sag of 15 ft, determine the length of the cable. The ends of the cable are supported at the same elevation.

$$w_0 = 5 \text{ lb/ft}$$

From Example 7-15,

$$y = \frac{F_H}{w_0} \left[\cosh \left(\frac{w_0}{F_H} x \right) - 1 \right]$$

$$\text{At } x = 150 \text{ ft, } y = 15 \text{ ft}$$

$$\frac{15w_0}{F_H} = \cosh \left(\frac{150w_0}{F_H} \right) - 1$$

$$F_H = 3762 \text{ lb}$$

$$s = \frac{F_H}{w_0} \sinh \left(\frac{w_0}{F_H} x \right)$$

$$s = 151.0 \text{ ft}$$

$$L = 2s = 302 \text{ ft} \quad \text{Ans}$$

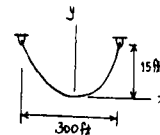

7-106. Show that the deflection curve of the cable discussed in Example 7-15 reduces to Eq. (4) in Example 7-14 when the *hyperbolic cosine function* is expanded in terms of a series and only the first two terms are retained. (The answer indicates that the *catenary* may be replaced by a *parabola* in the analysis of problems in which the sag is small. In this case, the cable weight is assumed to be uniformly distributed along the horizontal.)

$$\cosh x = 1 + \frac{x^2}{2!} + \dots$$

Substituting into

$$y = \frac{F_H}{w_0} \left[\cosh \left(\frac{w_0}{F_H} x \right) - 1 \right]$$

$$= \frac{F_H}{w_0} \left[1 + \frac{w_0^2 x^2}{2F_H^2} + \dots - 1 \right]$$

$$\cong \frac{w_0 x^2}{2F_H}$$

Using Eq. (3) in Example 7-14,

$$F_H = \frac{w_0 L^2}{8h}$$

$$\text{We get } y = \frac{4h}{L^2} x^2 \quad \text{QED}$$

7-107. A uniform cord is suspended between two points having the same elevation. Determine the sag-to-span ratio so that the maximum tension in the cord equals the cord's total weight.

From Example 7-15.

$$s = \frac{F_H}{w_0} \sinh\left(\frac{w_0 x}{F_H}\right)$$

$$y = \frac{F_H}{w_0} \left[\cosh\left(\frac{w_0 x}{F_H}\right) - 1 \right]$$

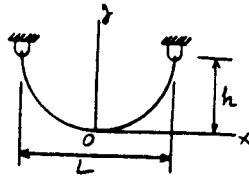

$$\tanh\left(\frac{w_0 L}{2F_H}\right) = \frac{1}{2}$$

$$\frac{w_0 L}{2F_H} = \tanh^{-1}(0.5) = 0.5493$$

At $x = \frac{L}{2}$,

when $x = \frac{L}{2}$, $y = h$

$$\left. \frac{dy}{dx} \right|_{\max} = \tan \theta_{\max} = \sinh\left(\frac{w_0 L}{2F_H}\right)$$

$$h = \frac{F_H}{w_0} \left[\cosh\left(\frac{w_0 x}{F_H}\right) - 1 \right]$$

$$\cos \theta_{\max} = \frac{1}{\cosh\left(\frac{w_0 L}{2F_H}\right)}$$



$$h = \frac{F_H}{w_0} \left\{ \frac{1}{\sqrt{1 - \tanh^2\left(\frac{w_0 L}{2F_H}\right)}} - 1 \right\} = 0.1547 \left(\frac{F_H}{w_0} \right)$$

$$T_{\max} = \frac{F_H}{\cos \theta_{\max}}$$

$$\frac{0.1547 L}{2h} = 0.5493$$

$$w_0(2s) = F_H \cosh\left(\frac{w_0 L}{2F_H}\right)$$

$$\frac{h}{L} = 0.141 \quad \text{Ans}$$

$$2F_H \sinh\left(\frac{w_0 L}{2F_H}\right) = F_H \cosh\left(\frac{w_0 L}{2F_H}\right)$$

*7-108. A cable has a weight of 2 lb/ft. If it can span 100 ft and has a sag of 12 ft, determine the length of the cable. The ends of the cable are supported from the same elevation.

From Eq. (5) of Example 7-15:

$$h = \frac{F_H}{w_0} \left[\cosh\left(\frac{w_0 L}{2F_H}\right) - 1 \right]$$

$$12 = \frac{F_H}{2} \left[\cosh\left(\frac{2(100)}{2F_H}\right) - 1 \right]$$

$$24 = F_H \left[\cosh\left(\frac{100}{F_H}\right) - 1 \right]$$

$$F_H = 212.2 \text{ lb}$$

From Eq. (3) of Example 7-15:

$$s = \frac{F_H}{w_0} \sinh\left(\frac{w_0}{F_H} x\right)$$

$$\frac{l}{2} = \frac{212.2}{2} \sinh\left(\frac{2(50)}{212.2}\right)$$

$$l = 104 \text{ ft} \quad \text{Ans}$$

7-109. The transmission cable having a weight of 20 lb/ft is strung across the river as shown. Determine the required force that must be applied to the cable at its points of attachment to the towers at *B* and *C*.

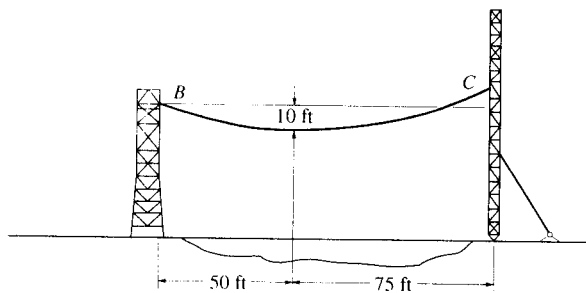

$$\bar{w} = 20 \text{ lb/ft}$$

From Example 7-15,

$$y = \frac{F_H}{w_0} \left[\cosh\left(\frac{w_0}{F_H}x\right) - 1 \right]$$

At *B*:

$$10 = \frac{F_H}{20} \left[\cosh\left(\frac{20}{F_H}(50)\right) - 1 \right]$$

Solving,

$$F_H = 2532 \text{ lb}$$

$$\frac{dy}{dx} = \sinh\left(\frac{w_0}{F_H}x\right) = \sinh\left(\frac{20(50)}{2532}\right) = 0.40529$$

$$\theta = \tan^{-1}(0.40529) = 22.06^\circ$$

$$(T_{max})_B = \frac{2532}{\cos 22.06^\circ} = 2732 \text{ lb} = 2.73 \text{ kip} \quad \text{Ans}$$

At *C*:

$$\frac{dy}{dx} = \sinh\left(\frac{w_0}{F_H}x\right) = \sinh\left(\frac{20(75)}{2532}\right) = 0.6277$$

$$\theta = \tan^{-1}(0.6277) = 32.12^\circ$$

$$(T_{max})_C = 2532/\cos 32.12^\circ = 2989 \text{ lb} = 2.99 \text{ kip} \quad \text{Ans}$$

7-110. The cable weighs 6 lb/ft and is 150 ft in length. Determine the sag h so that the cable spans 100 ft. Find the minimum tension in the cable.

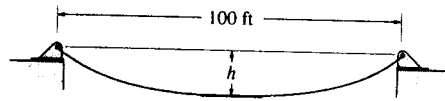

Deflection Curve of The Cable :

$$x = \int \frac{ds}{\left[1 + \left(\frac{1}{F_H}\right) (w_0 ds)^2\right]^{1/2}} \quad \text{where } w_0 = 6 \text{ lb/ft}$$

Performing the integration yields

$$x = \frac{F_H}{6} \left\{ \sinh^{-1} \left[\frac{1}{F_H} (6s + C_1) \right] + C_2 \right\} \quad [1]$$

From Eq. 7-14

$$\frac{dy}{dx} = \frac{1}{F_H} \int w_0 ds = \frac{1}{F_H} (6s + C_1) \quad [2]$$

Boundary Conditions :

$$\frac{dy}{dx} = 0 \text{ at } s = 0. \text{ From Eq. [2]} \quad 0 = \frac{1}{F_H} (0 + C_1) \quad C_1 = 0$$

Then, Eq. [2] becomes

$$\frac{dy}{dx} = \tan \theta = \frac{6s}{F_H} \quad [3]$$

$s = 0$ at $x = 0$ and use the result $C_1 = 0$. From Eq. [1]

$$x = \frac{F_H}{6} \left\{ \sinh^{-1} \left[\frac{1}{F_H} (0 + 0) \right] + C_2 \right\} \quad C_2 = 0$$

Rearranging Eq. [1], we have

$$s = \frac{F_H}{6} \sinh \left(\frac{6}{F_H} x \right) \quad [4]$$

Substituting Eq. [4] into [3] yields

$$\frac{dy}{dx} = \sinh \left(\frac{6}{F_H} x \right)$$

Performing the integration

$$y = \frac{F_H}{6} \cosh \left(\frac{6}{F_H} x \right) + C_3 \quad [5]$$

$y = 0$ at $x = 0$. From Eq. [5] $0 = \frac{F_H}{6} \cosh 0 + C_3$, thus, $C_3 = -\frac{F_H}{6}$

Then, Eq. [5] becomes

$$y = \frac{F_H}{6} \left[\cosh \left(\frac{6}{F_H} x \right) - 1 \right] \quad [6]$$

$s = 75$ ft at $x = 50$ ft. From Eq. [4]

$$75 = \frac{F_H}{6} \sinh \left[\frac{6}{F_H} (50) \right]$$

By trial and error

$$F_H = 184.9419 \text{ lb}$$

The maximum tension occurs at $\theta = \theta_{\text{min}} = 0^\circ$. Thus,

$$T_{\text{min}} = \frac{F_H}{\cos \theta_{\text{min}}} = \frac{184.9419}{\cos 0^\circ} = 185 \text{ lb}$$

Ans

$y = h$ at $x = 50$ ft. From Eq. [6]

$$h = \frac{184.9419}{6} \left\{ \cosh \left[\frac{6}{184.9419} (50) \right] - 1 \right\} = 50.3 \text{ ft} \quad \text{Ans}$$

7-111. A telephone line (cable) stretches between two points which are 150 ft apart and at the same elevation. The line sags 5 ft and the cable has a weight of 0.3 lb/ft. Determine the length of the cable and the maximum tension in the cable.

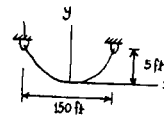
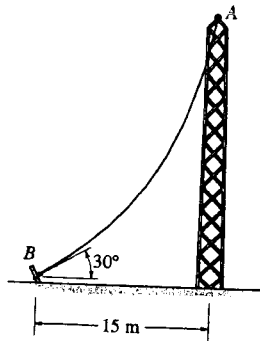

$$w = 0.3 \text{ lb/ft}$$

From Example 7-15,

$$s = \frac{F_H}{w} \sinh\left(\frac{w}{F_H} x\right)$$

$$y = \frac{F_H}{w} \left[\cosh\left(\frac{w}{F_H} x\right) - 1 \right]$$

$$\text{At } x = 75 \text{ ft, } y = 5 \text{ ft, } w = 0.3 \text{ lb/ft}$$

$$5 = \frac{F_H}{w} \left[\cosh\left(\frac{75w}{F_H}\right) - 1 \right]$$

$$F_H = 169.0 \text{ lb}$$

$$\left. \frac{dy}{dx} \right|_{\max} = \tan \theta_{\max} = \sinh\left(\frac{w}{F_H} x\right) \Big|_{x=75 \text{ ft}}$$

$$\theta_{\max} = \tan^{-1} \left[\sinh\left(\frac{75(0.3)}{169}\right) \right] = 7.606^\circ$$

$$T_{\max} = \frac{F_H}{\cos \theta_{\max}} = \frac{169}{\cos 7.606^\circ} = 170 \text{ lb} \quad \text{Ans}$$

$$s = \frac{169.0}{0.3} \sinh\left[\frac{0.3}{169.0}(75)\right] = 75.22$$

$$L = 2s = 150 \text{ ft} \quad \text{Ans}$$

7-112. The cable has a mass of 0.5 kg/m and is 25 m long. Determine the vertical and horizontal components of force it exerts on the top of the tower.

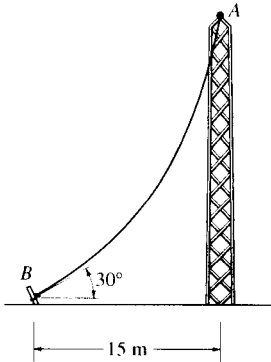

$$x = \int \frac{ds}{\left\{1 + \frac{1}{F_H^2} (w_0 ds)^2\right\}^{\frac{1}{2}}}$$

Performing the integration yields :

$$x = \frac{F_H}{4.905} \left\{ \sinh^{-1} \left[\frac{1}{F_H} (4.905s + C_1) \right] + C_2 \right\} \quad [1]$$

From Eq. 7-13

$$\frac{dy}{dx} = \frac{1}{F_H} \int w_0 ds$$

$$\frac{dy}{dx} = \frac{1}{F_H} (4.905s + C_1)$$

At $s = 0$; $\frac{dy}{dx} = \tan 30^\circ$. Hence $C_1 = F_H \tan 30^\circ$

$$\frac{dy}{dx} = \frac{4.905s}{F_H} + \tan 30^\circ \quad [2]$$

Applying boundary conditions at $x = 0$; $s = 0$ to Eq.[1] and using the result $C_1 = F_H \tan 30^\circ$ yields $C_2 = -\sinh^{-1}(\tan 30^\circ)$. Hence

$$x = \frac{F_H}{4.905} \left\{ \sinh^{-1} \left[\frac{1}{F_H} (4.905s + F_H \tan 30^\circ) \right] - \sinh^{-1}(\tan 30^\circ) \right\} \quad [3]$$

At $x = 15$ m; $s = 25$ m. From Eq.[3]

$$15 = \frac{F_H}{4.905} \left\{ \sinh^{-1} \left[\frac{1}{F_H} (4.905(25) + F_H \tan 30^\circ) \right] - \sinh^{-1}(\tan 30^\circ) \right\}$$

By trial and error $F_H = 73.94$ N

At point A, $s = 25$ m From Eq.[2]

$$\tan \theta_A = \left. \frac{dy}{dx} \right|_{s=25} = \frac{4.905(25)}{73.94} + \tan 30^\circ \quad \theta_A = 65.90^\circ$$

$$(F_v)_A = F_H \tan \theta_A = 73.94 \tan 65.90^\circ = 165 \text{ N} \quad \text{Ans}$$

$$(F_H)_A = F_H = 73.9 \text{ N} \quad \text{Ans}$$

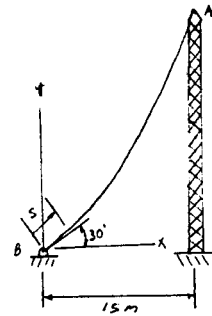

7-113. A 50-ft cable is suspended between two points a distance of 15 ft apart and at the same elevation. If the minimum tension in the cable is 200 lb, determine the total weight of the cable and the maximum tension developed in the cable.

$$T_{\min} = F_H = 200 \text{ lb}$$

From Example 7-15 :

$$s = \frac{F_H}{w_0} \sinh \left(\frac{w_0 x}{F_H} \right)$$

$$\frac{50}{2} = \frac{200}{w_0} \sinh \left(\frac{w_0}{200} \left(\frac{15}{2} \right) \right)$$

Solving,

$$w_0 = 79.9 \text{ lb/ft}$$

$$\text{Total weight} = w_0 l = 79.9 (50) = 4.00 \text{ kip} \quad \text{Ans}$$

$$\left. \frac{dy}{dx} \right|_{x=s} = \tan \theta_{\max} = \frac{w_0 s}{F_H}$$

$$\theta_{\max} = \tan^{-1} \left[\frac{79.9 (25)}{200} \right] = 84.3^\circ$$

Then,

$$T_{\max} = \frac{F_H}{\cos \theta_{\max}} = \frac{200}{\cos 84.3^\circ} = 2.01 \text{ kip} \quad \text{Ans}$$

7-114. The man picks up the 52-ft chain and holds it just high enough so it is completely off the ground. The chain has points of attachment *A* and *B* that are 50 ft apart. If the chain has a weight of 3 lb/ft, and the man weighs 150 lb, determine the force he exerts on the ground. Also, how high *h* must he lift the chain? *Hint*: The slopes at *A* and *B* are zero.

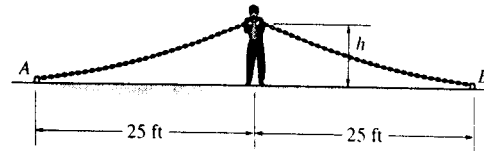

Deflection Curve of The Cable :

$$x = \int \frac{ds}{\left[1 + \left(\frac{1}{F_H^2}\right) \left(\int w_0 ds\right)^2\right]^{3/2}} \quad \text{where } w_0 = 3 \text{ lb/ft}$$

Performing the integration yields

$$x = \frac{F_H}{3} \left\{ \sinh^{-1} \left[\frac{1}{F_H} (3s + C_1) \right] + C_2 \right\} \quad [1]$$

From Eq. 7-14

$$\frac{dy}{dx} = \frac{1}{F_H} \int w_0 ds = \frac{1}{F_H} (3s + C_1) \quad [2]$$

Boundary Conditions :

$$\frac{dy}{dx} = 0 \text{ at } s = 0. \text{ From Eq. [2]} \quad 0 = \frac{1}{F_H} (0 + C_1) \quad C_1 = 0$$

Then, Eq. [2] becomes

$$\frac{dy}{dx} = \tan \theta = \frac{3s}{F_H} \quad [3]$$

$s = 0$ at $x = 0$ and use the result $C_1 = 0$. From Eq. [1]

$$x = \frac{F_H}{3} \left\{ \sinh^{-1} \left[\frac{1}{F_H} (0 + 0) \right] + C_2 \right\} \quad C_2 = 0$$

Rearranging Eq. [1], we have

$$s = \frac{F_H}{3} \sinh \left(\frac{3}{F_H} x \right) \quad [4]$$

Substituting Eq. [4] into [3] yields

$$\frac{dy}{dx} = \sinh \left(\frac{3}{F_H} x \right)$$

Performing the integration

$$y = \frac{F_H}{3} \cosh \left(\frac{3}{F_H} x \right) + C_3 \quad [5]$$

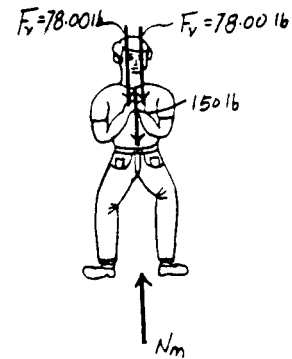
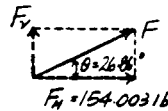

$$y = 0 \text{ at } x = 0. \text{ From Eq. [5]} \quad 0 = \frac{F_H}{3} \cosh 0 + C_3, \text{ thus, } C_3 = -\frac{F_H}{3}$$

Then, Eq. [5] becomes

$$y = \frac{F_H}{3} \left[\cosh \left(\frac{3}{F_H} x \right) - 1 \right] \quad [6]$$

$s = 26$ ft at $x = 25$ ft. From Eq. [4]

$$26 = \frac{F_H}{3} \sinh \left[\frac{3}{F_H} (25) \right]$$

By trial and error

$$F_H = 154.003 \text{ lb}$$

$y = h$ at $x = 25$ ft. From Eq. [6]

$$h = \frac{154.003}{3} \left\{ \cosh \left[\frac{3}{154.003} (25) \right] - 1 \right\} = 6.21 \text{ ft} \quad \text{Ans}$$

From Eq. [3]

$$\left. \frac{dy}{dx} \right|_{x=26 \text{ ft}} = \tan \theta = \frac{3(26)}{154.003} = 0.5065 \quad \theta = 26.86^\circ$$

The vertical force F_V that each chain exerts on the man is

$$F_V = F_H \tan \theta = 154.003 \tan 26.86^\circ = 78.00 \text{ lb}$$

Equation of Equilibrium : By considering the equilibrium of the man,

$$+\uparrow \Sigma F_y = 0; \quad N_m - 150 - 2(78.00) = 0 \quad N_m = 306 \text{ lb} \quad \text{Ans}$$

7-115. The balloon is held in place using a 400-ft cord that weighs 0.8 lb/ft and makes a 60° angle with the horizontal. If the tension in the cord at point A is 150 lb, determine the length of the cord, l , that is lying on the ground and the height h . *Hint:* Establish the coordinate system at B as shown.

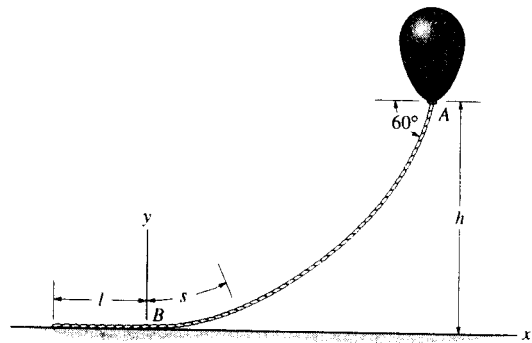

Deflection Curve of The Cable :

$$x = \int \frac{ds}{\left[1 + \left(\frac{1}{F_H^2}\right) (w_0 ds)^2\right]^{1/2}} \quad \text{where } w_0 = 0.8 \text{ lb/ft}$$

Performing the integration yields

$$x = \frac{F_H}{0.8} \left\{ \sinh^{-1} \left[\frac{1}{F_H} (0.8s + C_1) \right] + C_2 \right\} \quad [1]$$

From Eq. 7-14

$$\frac{dy}{dx} = \frac{1}{F_H} \int w_0 ds = \frac{1}{F_H} (0.8s + C_1) \quad [2]$$

Boundary Conditions :

$$\frac{dy}{dx} = 0 \text{ at } s = 0. \text{ From Eq. [2]} \quad 0 = \frac{1}{F_H} (0 + C_1) \quad C_1 = 0$$

Then, Eq. [2] becomes

$$\frac{dy}{dx} = \tan \theta = \frac{0.8s}{F_H} \quad [3]$$

$s = 0$ at $x = 0$ and use the result $C_1 = 0$. From Eq. [1]

$$x = \frac{F_H}{3} \left\{ \sinh^{-1} \left[\frac{1}{F_H} (0 + 0) \right] + C_2 \right\} \quad C_2 = 0$$

Rearranging Eq. [1], we have

$$s = \frac{F_H}{0.8} \sinh \left(\frac{0.8}{F_H} x \right) \quad [4]$$

Substituting Eq. [4] into [3] yields

$$\frac{dy}{dx} = \sinh \left(\frac{0.8}{F_H} x \right)$$

Performing the integration

$$y = \frac{F_H}{0.8} \cosh \left(\frac{0.8}{F_H} x \right) + C_3 \quad [5]$$

$y = 0$ at $x = 0$. From Eq. [5] $0 = \frac{F_H}{0.8} \cosh 0 + C_3$, thus, $C_3 = -\frac{F_H}{0.8}$

Then, Eq. [5] becomes

$$y = \frac{F_H}{0.8} \left[\cosh \left(\frac{0.8}{F_H} x \right) - 1 \right] \quad [6]$$

The tension developed at the end of the cord is $T = 150$ lb and $\theta = 60^\circ$. Thus

$$T = \frac{F_H}{\cos \theta} \quad 150 = \frac{F_H}{\cos 60^\circ} \quad F_H = 75.0 \text{ lb}$$

From Eq. [3]

$$\frac{dy}{dx} = \tan 60^\circ = \frac{0.8s}{75} \quad s = 162.38 \text{ ft}$$

Thus,

$$l = 400 - 162.38 = 238 \text{ ft}$$

Substituting $s = 162.38$ ft into Eq. [4],

Ans

$$162.38 = \frac{75}{0.8} \sinh \left(\frac{0.8}{75} x \right) \quad x = 123.46 \text{ ft}$$

$y = h$ at $x = 123.46$ ft. From Eq. [6]

$$h = \frac{75.0}{0.8} \left[\cosh \left[\frac{0.8}{75.0} (123.46) \right] - 1 \right] = 93.75 \text{ ft} \quad \text{Ans}$$

7-11. A 100-lb cable is attached between two points at a distance 50 ft apart having equal elevations. If the maximum tension developed in the cable is 75 lb, determine the length of the cable and the sag.

From Example 7-15,

$$T_{max} = \frac{F_H}{\cos \theta_{max}} = 75 \text{ lb}$$

$$\cos \theta_{max} = \frac{F_H}{75}$$

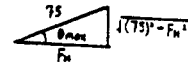

For $\frac{1}{2}$ of cable,

$$w_0 = \frac{\frac{100}{2}}{s} = \frac{50}{s}$$

$$\tan \theta_{max} = \frac{w_0 s}{F_H} = \frac{\sqrt{(75)^2 - F_H^2}}{F_H} = \frac{50}{F_H}$$

Thus,

$$\sqrt{(75)^2 - F_H^2} = 50; \quad F_H = 55.9 \text{ lb}$$

$$s = \frac{F_H}{w_0} \sinh \left(\frac{w_0 s}{F_H} \right) = \frac{55.9}{\left(\frac{50}{s} \right)} \sinh \left\{ \left(\frac{50}{s(55.9)} \right) \left(\frac{50}{2} \right) \right\}$$

$$s = 27.8 \text{ ft}$$

$$w_0 = \frac{50}{27.8} = 1.80 \text{ lb/ft}$$

$$\text{Total length} = 2s = 55.6 \text{ ft} \quad \text{Ans}$$

$$h = \frac{F_H}{w_0} \left[\cosh \left(\frac{w_0 L}{2 F_H} \right) - 1 \right] = \frac{55.9}{1.80} \left[\cosh \left(\frac{1.80(50)}{2(55.9)} \right) - 1 \right]$$

$$= 10.6 \text{ ft} \quad \text{Ans}$$

7-117. Determine the distance a between the supports in terms of the beam's length L so that the moment in the symmetric beam is zero at the beam's center.

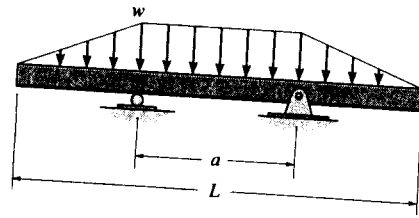

Support Reactions : From FBD (a),

$$\sum M_C = 0; \quad \frac{w}{2}(L+a)\left(\frac{a}{2}\right) - B_y(a) = 0 \quad B_y = \frac{w}{4}(L+a)$$

Free body Diagram : The FBD for segment AC sectioned through point C is drawn.

Internal Forces : This problem requires $M_C = 0$. Summing moments about point C [FBD (b)], we have

$$\begin{aligned} \sum M_C = 0; \quad & \frac{wa}{2}\left(\frac{a}{4}\right) + \frac{w}{4}(L-a)\left[\frac{1}{6}(2a+L)\right] \\ & - \frac{w}{4}(L+a)\left(\frac{a}{2}\right) = 0 \\ & 2a^2 + 2aL - L^2 = 0 \\ & a = 0.366L \end{aligned}$$

Ans

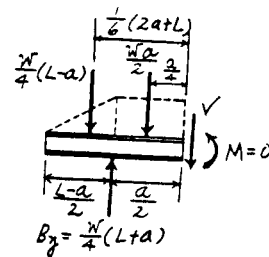
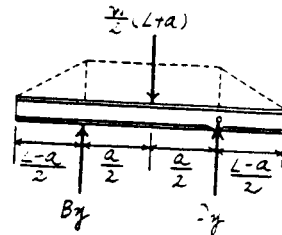

7-118. Draw the shear and moment diagrams for the beam.

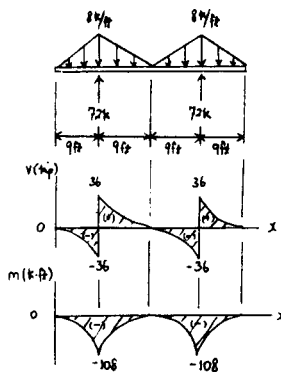
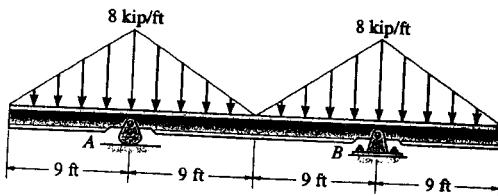

7-11. Draw the shear and moment diagrams for the beam ABC.

Support Reactions: The 6 kN load can be replaced by an equivalent force and couple moment at B as shown on FBD (a).

$$\begin{aligned} \sum M_A = 0; & F_{CD} \sin 45^\circ (6) - 6(3) - 9.00 = 0 & F_{CD} = 6.364 \text{ kN} \\ \sum F_y = 0; & A_y + 6.364 \sin 45^\circ - 6 = 0 & A_y = 1.50 \text{ kN} \end{aligned}$$

Shear and Moment Functions: For $0 \leq x < 3 \text{ m}$ [FBD (b)].

$$\sum F_y = 0; \quad 1.50 - V = 0 \quad V = 1.50 \text{ kN} \quad \text{Ans}$$

$$\sum M = 0; \quad M - 1.50x = 0 \quad M = (1.50x) \text{ kN} \cdot \text{m} \quad \text{Ans}$$

For $3 \text{ m} < x \leq 6 \text{ m}$ [FBD (c)].

$$\sum F_y = 0; \quad V + 6.364 \sin 45^\circ = 0 \quad V = -4.50 \text{ kN} \quad \text{Ans}$$

$$\sum M = 0; \quad 6.364 \sin 45^\circ (6-x) - M = 0 \\ M = (27.0 - 4.50x) \text{ kN} \cdot \text{m} \quad \text{Ans}$$

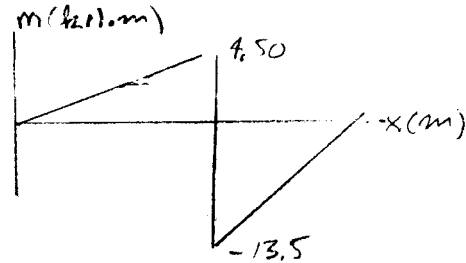
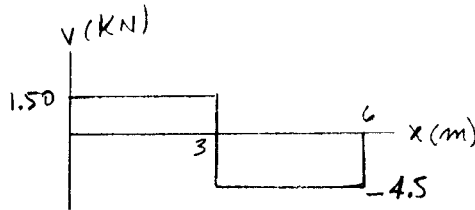
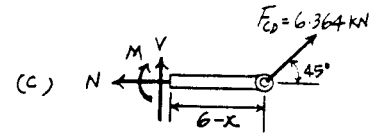
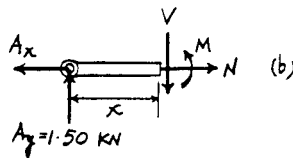
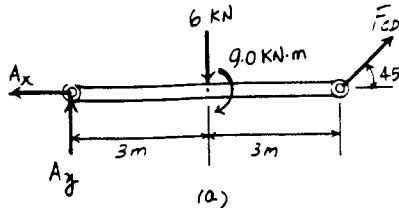
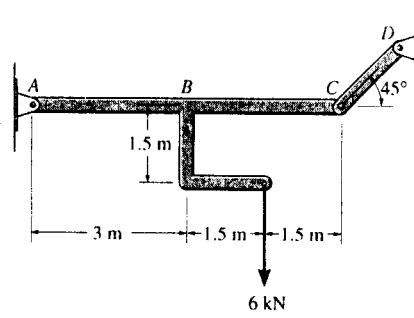

7-120. Draw the shear and moment diagrams for the beam.

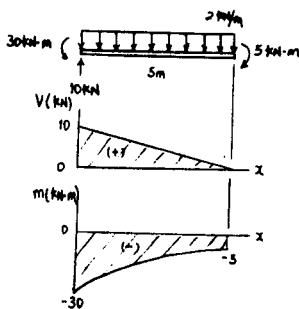
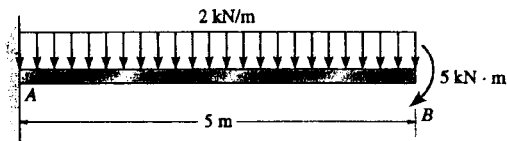

7-121. Determine the normal force, shear force, and moment at points *B* and *C* of the beam.

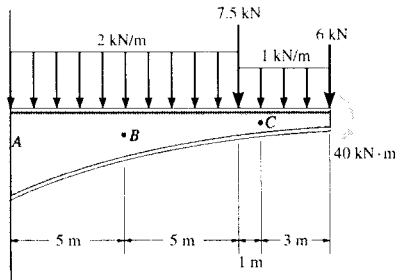

Free body Diagram: The Support reactions need not be computed for this case.

Internal Forces: Applying the equations of equilibrium to segment *DC* [FBD (a)], we have

$$\rightarrow \Sigma F_x = 0; \quad N_C = 0 \quad \text{Ans}$$

$$+ \uparrow \Sigma F_y = 0; \quad V_C - 3.00 - 6 = 0 \quad V_C = 9.00 \text{ kN} \quad \text{Ans}$$

$$\curvearrowleft + \Sigma M_C = 0; \quad -M_C - 3.00(1.5) - 6(3) - 40 = 0$$

$$M_C = -62.5 \text{ kN}\cdot\text{m} \quad \text{Ans}$$

Applying the equations of equilibrium to segment *DB* [FBD (b)], we have

$$\rightarrow \Sigma F_x = 0; \quad N_B = 0 \quad \text{Ans}$$

$$+ \uparrow \Sigma F_y = 0; \quad V_B - 10.0 - 7.5 - 4.00 - 6 = 0$$

$$V_B = 27.5 \text{ kN} \quad \text{Ans}$$

$$\curvearrowleft + \Sigma M_B = 0; \quad -M_B - 10.0(2.5) - 7.5(5)$$

$$- 4.00(7) - 6(9) - 40 = 0$$

$$M_B = -184.5 \text{ kN}\cdot\text{m} \quad \text{Ans}$$

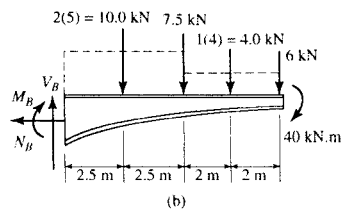
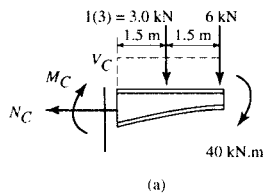

7-122. A chain is suspended between points at the same elevation and spaced a distance of 60 ft apart. If it has a weight of 0.5 lb/ft and the sag is 3 ft, determine the maximum tension in the chain.

$$x = \int \frac{ds}{\left[1 + \frac{1}{F_H^2} (w_0 ds)^2\right]^{1/2}}$$

Performing the integration yields :

$$x = \frac{F_H}{0.5} \left\{ \sinh^{-1} \left[\frac{1}{F_H} (0.5s + C_1) \right] + C_2 \right\} \quad [1]$$

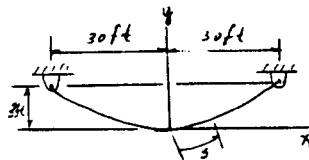

From Eq. 7-13

$$\frac{dy}{dx} = \frac{1}{F_H} \int w_0 ds$$

$$\frac{dy}{dx} = \frac{1}{F_H} (0.5s + C_1)$$

At $s = 0$; $\frac{dy}{dx} = 0$ hence $C_1 = 0$

$$\frac{dy}{dx} = \tan \theta = \frac{0.5s}{F_H} \quad [2]$$

Applying boundary conditions at $x = 0$; $s = 0$ to Eq. [1] and using the result $C_1 = 0$ yields $C_2 = 0$. Hence

$$s = \frac{F_H}{0.5} \sinh \left(\frac{0.5}{F_H} x \right) \quad [3]$$

Substituting Eq. [3] into [2] yields :

$$\frac{dy}{dx} = \sinh \left(\frac{0.5x}{F_H} \right) \quad [4]$$

Performing the integration

$$y = \frac{F_H}{0.5} \cosh \left(\frac{0.5}{F_H} x \right) + C_3$$

Applying boundary conditions at $x = 0$; $y = 0$ yields $C_3 = -\frac{F_H}{0.5}$. Therefore

$$y = \frac{F_H}{0.5} \left[\cosh \left(\frac{0.5}{F_H} x \right) - 1 \right]$$

$$\text{At } x = 30 \text{ ft; } y = 3 \text{ ft} \quad 3 = \frac{F_H}{0.5} \left[\cosh \left(\frac{0.5}{F_H} (30) \right) - 1 \right]$$

By trial and error $F_H = 75.25 \text{ lb}$

At $x = 30 \text{ ft}$; $\theta = \theta_{max}$. From Eq. [4]

$$\tan \theta_{max} = \frac{dy}{dx} \Big|_{x=30 \text{ ft}} = \sinh \left(\frac{0.5(30)}{75.25} \right) \quad \theta_{max} = 11.346^\circ$$

$$T_{max} = \frac{F_H}{\cos \theta_{max}} = \frac{75.25}{\cos 11.346^\circ} = 76.7 \text{ lb.} \quad \text{Ans}$$

7-123. Draw the shear and moment diagrams for the beam.

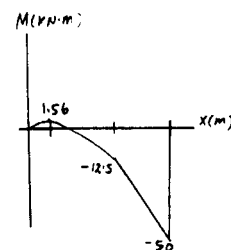
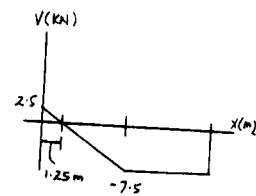
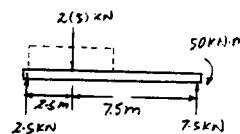
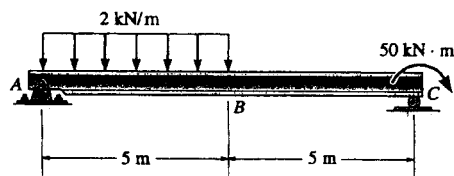

8-1. The mine car and its contents have a total mass of 6 Mg and a center of gravity at G . If the coefficient of static friction between the wheels and the tracks is $\mu_s = 0.4$ when the wheels are locked, find the normal force acting on the front wheels at B and the rear wheels at A when (a) only the brakes at A are locked, and (b) the brakes at both A and B are locked. In either case, does the car move?

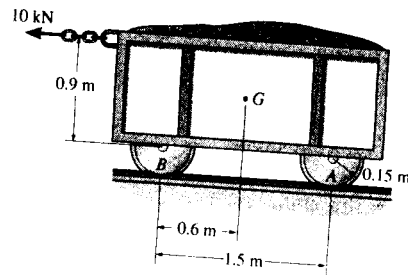

Equations of Equilibrium: The normal reactions acting on the wheels at (A and B) are independent as to whether the wheels are locked or not. Hence, The normal reactions acting on the wheels are the same for both cases.

$$\begin{aligned} \sum M_B = 0; \quad N_A(1.5) + 10(1.05) - 58.86(0.6) &= 0 \\ N_A &= 16.544 \text{ kN} = 16.5 \text{ kN} \quad \text{Ans} \end{aligned}$$

$$\begin{aligned} \sum F_y = 0; \quad N_B + 16.544 - 58.86 &= 0 \\ N_B &= 42.316 \text{ kN} = 42.3 \text{ kN} \quad \text{Ans} \end{aligned}$$

Friction: When the wheels at A are locked, $(F_A)_{\max} = \mu_s N_A = 0.4(16.544) = 6.6176 \text{ kN}$. Since $(F_A)_{\max} < 10 \text{ kN}$, the wheels at A will slip and the wheels at B will roll. Thus, **the mine car moves.**

When both wheels at A and B are locked, then $(F_A)_{\max} = \mu_s N_A = 0.4(16.544) = 6.6176 \text{ kN}$ and $(F_B)_{\max} = \mu_s N_B = 0.4(42.316) = 16.9264 \text{ kN}$. Since $(F_A)_{\max} + (F_B)_{\max} = 23.544 \text{ kN} > 10 \text{ kN}$, the wheels do not slip. Thus, **the mine car does not move.**

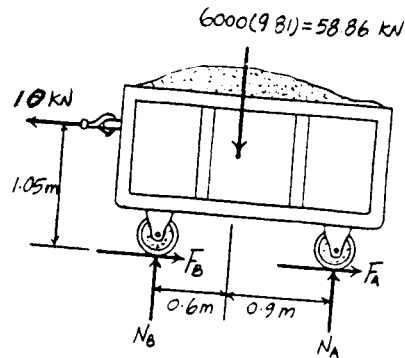

8-2. If the horizontal force $P = 80 \text{ lb}$, determine the normal and frictional forces acting on the 300-lb crate. Take $\mu_s = 0.3$, $\mu_k = 0.2$.

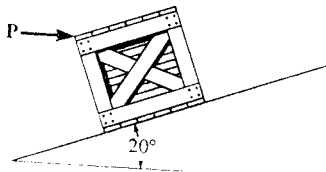

Assume no slipping:

$$\sum F_x = 0; \quad 80 \cos 20^\circ - 300 \sin 20^\circ + F_c = 0$$

$$F_c = 27.43 \text{ lb}$$

$$\sum F_y = 0; \quad N_c - 300 \cos 20^\circ - 80 \sin 20^\circ = 0$$

$$N_c = 309.26 \text{ lb}$$

$$(F_c)_{\max} = \mu_s N_c; \quad (F_c)_{\max} = 0.3(309.26) = 92.8 \text{ lb} > 27.43 \text{ lb} \quad (\text{O.K.})$$

$$F_c = 27.4 \text{ lb} \quad \text{Ans}$$

$$N_c = 309 \text{ lb} \quad \text{Ans}$$

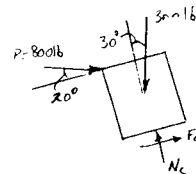

8-3. The uniform pole has a weight of 30 lb and a length of 26 ft. If it is placed against the smooth wall and on the rough floor in the position $d = 10$ ft, will it remain in this position when it is released? The coefficient of static friction is $\mu_s = 0.3$.

$$\left(+ \sum M_A = 0; \quad 30(5) - N_B(24) = 0 \right.$$

$$N_B = 6.25 \text{ lb}$$

$$\rightarrow \sum F_x = 0; \quad 6.25 - F_A = 0$$

$$F_A = 6.25 \text{ lb}$$

$$+ \uparrow \sum F_y = 0; \quad N_A - 30 = 0$$

$$N_A = 30 \text{ lb}$$

$$(F_A)_{\max} = 0.3(30) = 9 \text{ lb} > 6.25 \text{ lb}$$

Yes, the pole will remain stationary. **Ans**

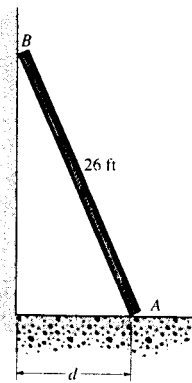
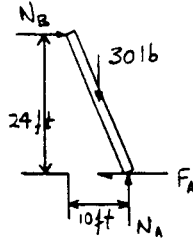

*8-4. The uniform pole has a weight of 30 lb and a length of 26 ft. Determine the maximum distance d it can be placed from the smooth wall and not slip. The coefficient of static friction between the floor and the pole is $\mu_s = 0.3$.

$$+ \uparrow \sum F_y = 0; \quad N_A - 30 = 0$$

$$N_A = 30 \text{ lb}$$

$$F_A = (F_A)_{\max} = 0.3(30) = 9 \text{ lb}$$

$$\rightarrow \sum F_x = 0; \quad N_B - 9 = 0$$

$$N_B = 9 \text{ lb}$$

$$\left(+ \sum M_A = 0; \quad 30(13 \cos \theta) - 9(26 \sin \theta) = 0 \right.$$

$$\theta = 59.04^\circ$$

$$d = 26 \cos 59.04^\circ = 13.4 \text{ ft} \quad \mathbf{Ans}$$

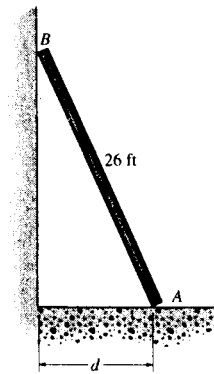
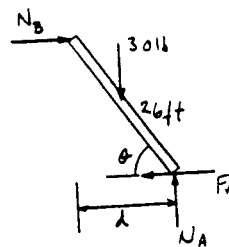

8-5. The uniform 20-lb ladder rests on the rough floor for which the coefficient of static friction is $\mu_s = 0.8$ and against the smooth wall at B . Determine the horizontal force P the man must exert on the ladder in order to cause it to move.

Assume that the ladder tips about A :

$$N_B = 0;$$

$$\rightarrow \Sigma F_x = 0; \quad P - F_A = 0$$

$$+\uparrow \Sigma F_y = 0; \quad -20 + N_A = 0$$

$$N_A = 20 \text{ lb}$$

$$(\rightarrow \Sigma M_A = 0; \quad 20(3) - P(4) = 0$$

$$P = 15 \text{ lb}$$

Thus

$$F_A = 15 \text{ lb}$$

$$(F_A)_{max} = 0.8(20) = 16 \text{ lb} > 15 \text{ lb} \quad \text{OK}$$

Ladder tips as assumed.

$$P = 15 \text{ lb} \quad \text{Ans}$$

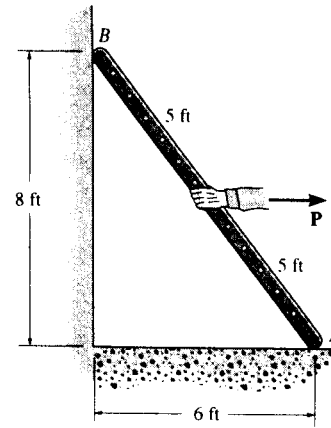
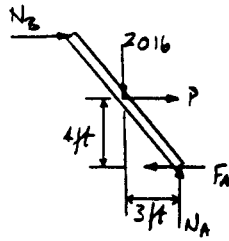

8-6. The uniform 20-lb ladder rests on the rough floor for which the coefficient of static friction is $\mu_s = 0.4$ and against the smooth wall at B . Determine the horizontal force P the man must exert on the ladder in order to cause it to move.

Assume that the ladder slips at A :

$$F_A = 0.4 N_A$$

$$+\uparrow \Sigma F_y = 0; \quad N_A - 20 = 0$$

$$N_A = 20 \text{ lb}$$

$$F_A = 0.4(20) = 8 \text{ lb}$$

$$(\rightarrow \Sigma M_B = 0; \quad P(4) - 20(3) + 20(6) - 8(8) = 0$$

$$P = 1 \text{ lb} \quad \text{Ans}$$

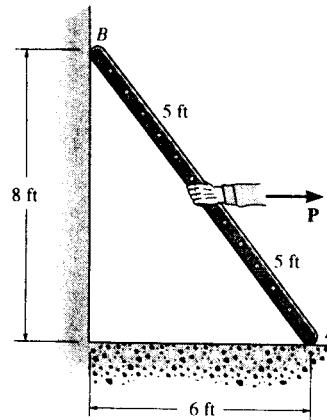
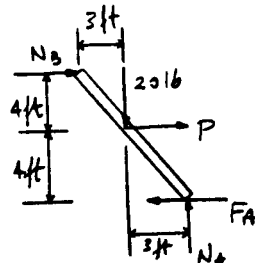

$$\rightarrow \Sigma F_x = 0; \quad N_B + 1 - 8 = 0$$

$$N_B = 7 \text{ lb} > 0 \quad \text{OK}$$

The ladder will remain in contact with the wall.

8-7. An axial force of $T = 800$ lb is applied to the bar. If the coefficient of static friction at the jaws C and D is $\mu_s = 0.5$, determine the smallest normal force that the screw at A must exert on the smooth surface of the links at B and C in order to hold the bar stationary. The links are pin-connected at F and G .

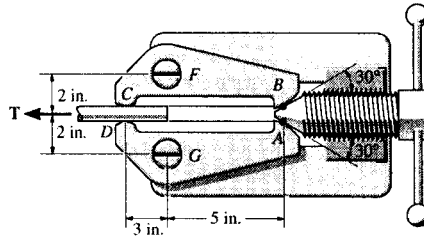

Require $F_C = \mu_s N_C$

$$400 = 0.5 N_C$$

$$N_C = 800 \text{ lb}$$

Ans

$$\begin{aligned} +\Sigma M_F = 0; & \quad -800(3) - 400(2) - (N_B \sin 30^\circ)(2) \\ & \quad + (N_B \cos 30^\circ)(5) = 0 \end{aligned}$$

$$N_B = 961 \text{ lb}$$

Ans

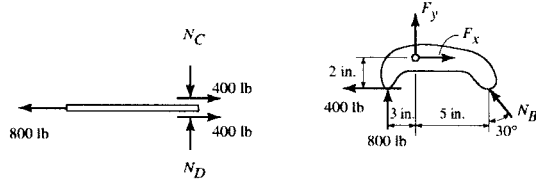

*8-8. The winch on the truck is used to hoist the garbage bin onto the bed of the truck. If the loaded bin has a weight of 8500 lb and center of gravity at G , determine the force in the cable needed to begin the lift. The coefficients of static friction at A and B are $\mu_A = 0.3$ and $\mu_B = 0.2$, respectively. Neglect the height of the support at A .

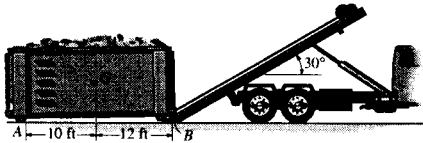

$$+\Sigma M_B = 0; \quad 8500(12) - N_A(22) = 0$$

$$N_A = 4636.364 \text{ lb}$$

$$\rightarrow \Sigma F_x = 0; \quad T \cos 30^\circ$$

$$- 0.2 N_B \cos 30^\circ - N_B \sin 30^\circ - 0.3(4636.364) = 0$$

$$T(0.86603) - 0.67321 N_B = 1390.91$$

$$+\uparrow \Sigma F_y = 0; \quad 4636.364 - 8500 + T \sin 30^\circ + N_B \cos 30^\circ$$

$$- 0.2 N_B \sin 30^\circ = 0$$

$$T(0.5) + 0.766025 N_B = 3863.636$$

Solving;

$$T = 3666.5 \text{ lb} = 3.67 \text{ kip}$$

Ans

$$N_B = 2650.5 \text{ lb}$$

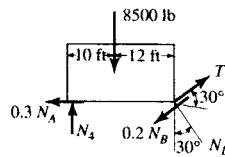

8-9. The 15-ft ladder has a uniform weight of 80 lb and rests against the smooth wall at B . If the coefficient of static friction at A is $\mu_A = 0.4$, determine if the ladder will slip. Take $\theta = 60^\circ$.

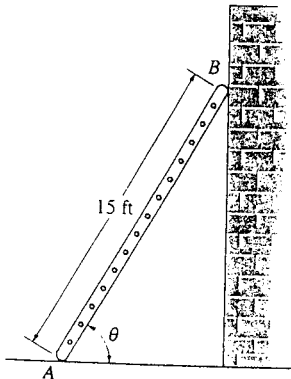

$$+\Sigma M_A = 0; \quad N_B(15 \sin 60^\circ) - 80(7.5) \cos 60^\circ = 0$$

$$N_B = 23.094 \text{ lb}$$

$$\rightarrow \Sigma F_x = 0; \quad F_A = 23.094 \text{ lb}$$

$$+\uparrow \Sigma F_y = 0; \quad N_A = 80 \text{ lb}$$

$$(F_A)_{\max} = 0.4(80) = 32 \text{ lb} > 23.094 \text{ lb} \quad (\text{O.K.})$$

The ladder will not slip. Ans

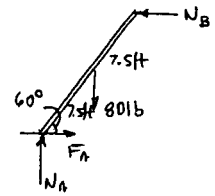

8-10. The block brake is used to stop the wheel from rotating when the wheel is subjected to a couple moment M_0 . If the coefficient of static friction between the wheel and the block is μ_s , determine the smallest force P that should be applied.

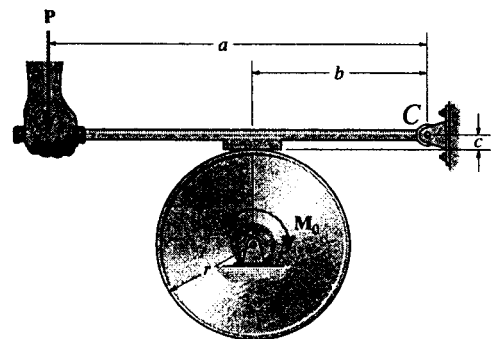

$$\left(\sum M_C = 0; \quad Pa - Nb + \mu_s Nc = 0\right.$$

$$N = \frac{Pa}{(b - \mu_s c)}$$

$$\left(\sum M_O = 0; \quad \mu_s N r - M_0 = 0\right.$$

$$\mu_s P \left(\frac{a}{b - \mu_s c} \right) r = M_0$$

$$P = \frac{M_0}{\mu_s r a} (b - \mu_s c) \quad \text{Ans}$$

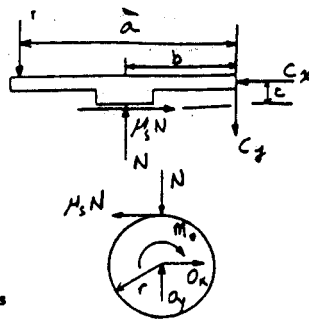

8-11. Show that the brake in Prob. 8-10 is self locking, i.e., $P \leq 0$, provided $b/c \leq \mu_s$.

See solution to Prob. 8-10. Require $P \leq 0$. Then

$$b \leq \mu_s c$$

$$\mu_s \geq \frac{b}{c} \quad \text{Ans}$$

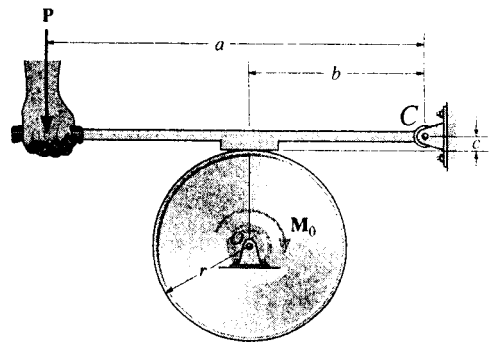

*8-12. Solve Prob. 8-10 if the couple moment M_0 is applied counterclockwise.

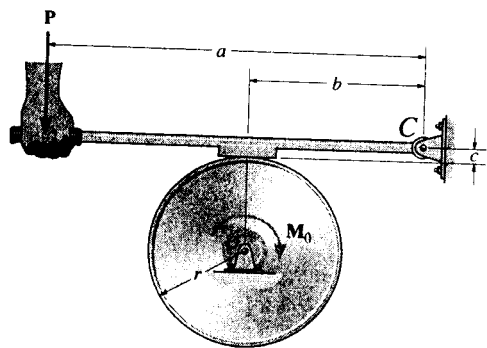

$$\left(\sum M_C = 0; \quad Pa - Nb - \mu_s Nc = 0 \right.$$

$$N = \frac{Pa}{(b + \mu_s c)}$$

$$\left(\sum M_O = 0; \quad \mu_s N r - M_0 = 0 \right.$$

$$\mu_s P \left(\frac{a}{b + \mu_s c} \right) r = M_0$$

$$P = \frac{M_0}{\mu_s r a} (b + \mu_s c) \quad \text{Ans}$$

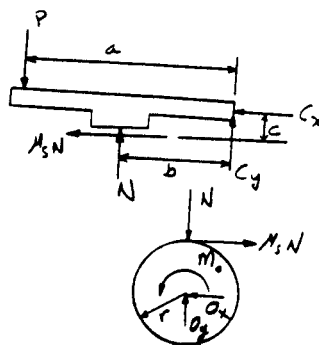

8-13. The block brake consists of a pin-connected lever and friction block at B . The coefficient of static friction between the wheel and the lever is $\mu_s = 0.3$, and a torque of $5 \text{ N} \cdot \text{m}$ is applied to the wheel. Determine if the brake can hold the wheel stationary when the force applied to the lever is (a) $P = 30 \text{ N}$, (b) $P = 70 \text{ N}$.

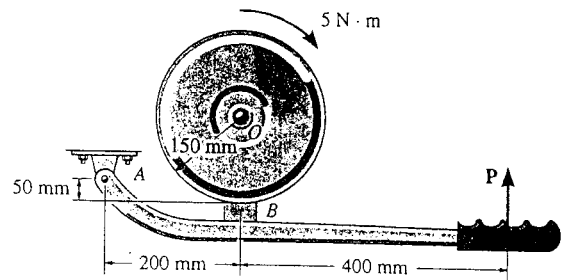

To hold lever:

$$\zeta + \Sigma M_O = 0; \quad F_B(0.15) - 5 = 0; \quad F_B = 33.333 \text{ N}$$

Require

$$N_B = \frac{33.333 \text{ N}}{0.3} = 111.1 \text{ N}$$

Lever:

$$\zeta + \Sigma M_A = 0; \quad P_{\text{Reqd.}}(0.6) - 111.1(0.2) - 33.333(0.05) = 0$$

$$P_{\text{Reqd.}} = 39.8 \text{ N}$$

a) $P = 30 \text{ N} < 39.8 \text{ N}$ No **Ans**

b) $P = 70 \text{ N} > 39.8 \text{ N}$ Yes **Ans**

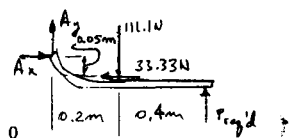
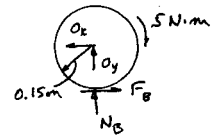

8-14. Solve Prob. 8-13 if the $5\text{-N} \cdot \text{m}$ torque is applied counter-clockwise.

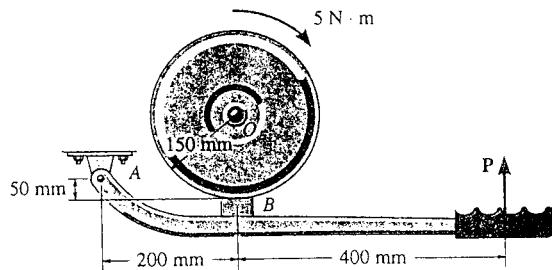

To hold lever:

$$\zeta + \Sigma M_O = 0; \quad -F_B(0.15) + 5 = 0; \quad F_B = 33.333 \text{ N}$$

Require

$$N_B = \frac{33.333 \text{ N}}{0.3} = 111.1 \text{ N}$$

Lever:

$$\zeta + \Sigma M_A = 0; \quad P_{\text{Reqd.}}(0.6) - 111.1(0.2) + 33.333(0.05) = 0$$

$$P_{\text{Reqd.}} = 34.26 \text{ N}$$

a) $P = 30 \text{ N} < 34.26 \text{ N}$ No **Ans**

b) $P = 70 \text{ N} > 34.26 \text{ N}$ Yes **Ans**

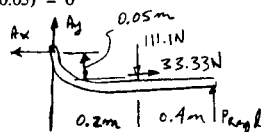
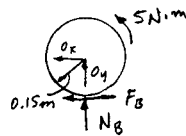

8-15. The tractor has a weight of 4500 lb with center of gravity at G . The driving traction is developed at the rear wheels B , while the front wheels at A are free to roll. If the coefficient of static friction between the wheels at B and the ground is $\mu_s = 0.5$, determine if it is possible to pull at $P = 1200$ lb without causing the wheels at B to slip or the front wheels at A to lift off the ground.

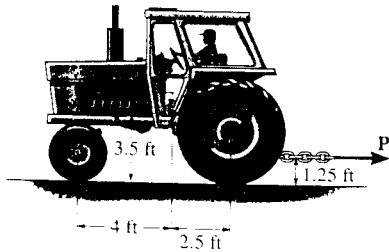

Slipping :

$$\zeta + \Sigma M_A = 0; \quad -4500(4) - P(1.25) + N_B(6.5) = 0$$

$$\rightarrow \Sigma F_x = 0; \quad P = 0.5 N_B$$

$$P = 1531.9 \text{ lb}$$

$$N_B = 3063.8 \text{ lb}$$

Tipping ($N_A = 0$)

$$\zeta + \Sigma M_B = 0; \quad -P(1.25) + 4500(2.5) = 0$$

$$P = 9000 \text{ lb}$$

Since $P_{required} = 1200 \text{ lb} < 1531.9 \text{ lb}$

It is possible to pull the load without slipping or tipping.

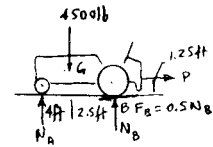

Ans

8-16. The car has a mass of 1.6 Mg and center of mass at G . If the coefficient of static friction between the shoulder of the road and the tires is $\mu_s = 0.4$, determine the greatest slope θ the shoulder can have without causing the car to slip or tip over if the car travels along the shoulder at constant velocity.

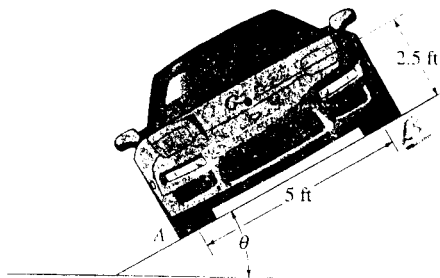

Tipping :

$$\zeta + \Sigma M_A = 0; \quad -W \cos \theta (2.5) + W \sin \theta (2.5) = 0$$

$$\tan \theta = 1$$

$$\theta = 45^\circ$$

Slipping :

$$\Sigma F_x = 0; \quad 0.4 N - W \sin \theta = 0$$

$$\Sigma F_y = 0; \quad N - W \cos \theta = 0$$

$$\tan \theta = 0.4$$

$$\theta = 21.8^\circ \quad \text{Ans (car slips)}$$

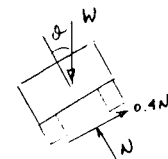
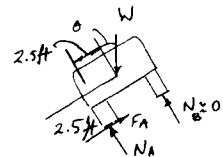

8-17. The drum has a weight of 100 lb and rests on the floor for which the coefficient of static friction is $\mu_s = 0.6$. If $a = 2$ ft and $b = 3$ ft, determine the smallest magnitude of the force P that will cause impending motion of the drum.

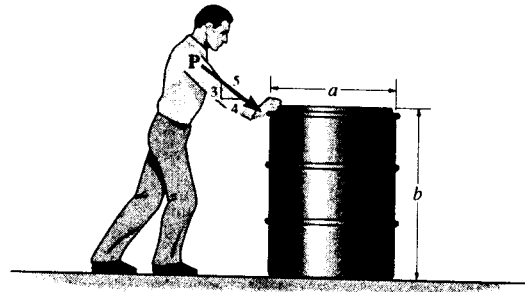

Assume that the drum tips :

$$x = 1 \text{ ft}$$

$$\left(+\Sigma M_O = 0; \quad 100(1) + P\left(\frac{3}{5}\right)(2) - P\left(\frac{4}{5}\right)(3) = 0 \right.$$

$$P = 83.3 \text{ lb}$$

$$\rightarrow \Sigma F_x = 0; \quad -F + 83.3\left(\frac{4}{5}\right) = 0$$

$$F = 66.7 \text{ lb}$$

$$+\uparrow \Sigma F_y = 0; \quad N - 100 - 83.3\left(\frac{3}{5}\right) = 0$$

$$N = 150 \text{ lb}$$

$$F_{max} = 0.6(150) = 90 \text{ lb} > 66.7 \quad \text{OK}$$

Drum tips as assumed.

$$P = 83.3 \text{ lb} \quad \text{Ans}$$

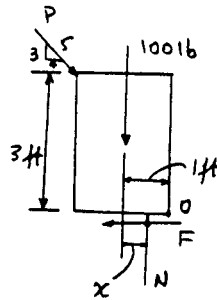

8-18. The drum has a weight of 100 lb and rests on the floor for which the coefficient of static friction is $\mu_s = 0.5$. If $a = 3$ ft and $b = 4$ ft, determine the smallest magnitude of the force P that will cause impending motion of the drum.

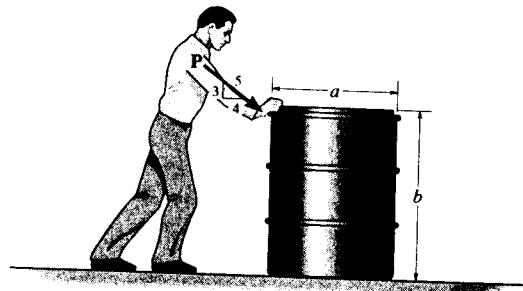

Assume that the drum slips :

$$F = 0.5N$$

$$\rightarrow \Sigma F_x = 0; \quad -0.5N + P\left(\frac{4}{5}\right) = 0$$

$$+\uparrow \Sigma F_y = 0; \quad -P\left(\frac{3}{5}\right) - 100 + N = 0$$

$$P = 100 \text{ lb}$$

$$N = 160 \text{ lb}$$

$$\left(+\Sigma M_O = 0; \quad 160(x) + 100\left(\frac{3}{5}\right)(1.5) - 100\left(\frac{4}{5}\right)(4) = 0 \right.$$

$$x = 1.44 \text{ ft} < 1.5 \text{ ft} \quad \text{OK}$$

Drum slips as assumed.

$$P = 100 \text{ lb} \quad \text{Ans}$$

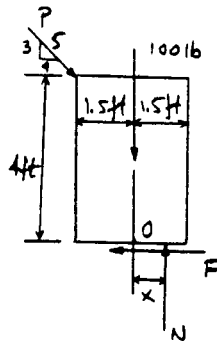

8-19. The coefficient of static friction between the shoes at A and B of the tongs and the pallet is $\mu_s = 0.5$, and between the pallet and the floor $\mu_s = 0.4$. If a horizontal towing force of $P = 300$ N is applied to the tongs, determine the largest mass that can be towed.

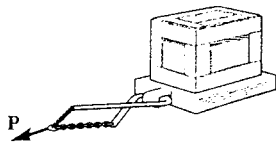
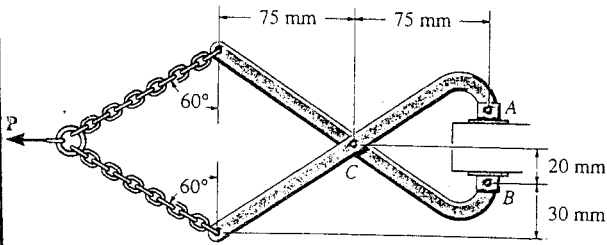

Chain:

$$+\uparrow \Sigma F_y = 0; \quad 2T \sin 60^\circ - 300 = 0$$

$$T = 173.2 \text{ N}$$



Tongs:

$$+\circlearrowleft \Sigma M_C = 0; \quad -173.2 \cos 60^\circ (75) - 173.2 \sin 60^\circ (50) + N_A (75) - F_A (20) = 0$$

$$F = \mu N; \quad F_A = 0.5 N_A$$

$$F_A = 107.7 \text{ N}$$

Cratic:

$$+\rightarrow \Sigma F_x = 0; \quad F = 2(107.7) = 215.3 \text{ N}$$

$$F = \mu N; \quad F = 0.4 N$$

$$N = 538.3 \text{ N}$$

$$+\uparrow \Sigma F_y = 0; \quad W = 538.3 \text{ N}$$

$$m = \frac{538.3}{9.81} = 54.9 \text{ kg} \quad \text{Ans}$$

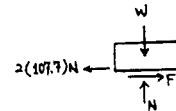
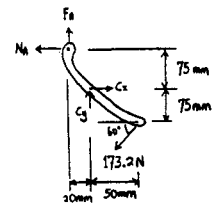

*8-20. The pipe is hoisted using the tongs. If the coefficient of static friction at A and B is μ_s , determine the smallest dimension b so that any pipe of inner diameter d can be lifted.

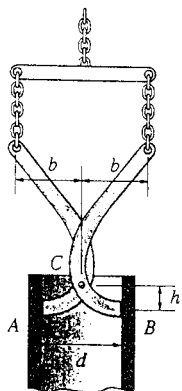

Require:

$$F_B = \frac{W}{2} \leq \mu_s N_B$$

$$+\circlearrowleft \Sigma M_C = 0; \quad -\frac{W}{2} \left(\frac{d}{2}\right) - N_A (h) + b \left(\frac{W}{2}\right) = 0$$

$$N_B = \frac{W}{2h} \left(b - \frac{d}{2}\right)$$

Thus,

$$\frac{W}{2} \leq \frac{\mu_s W}{2h} \left(b - \frac{d}{2}\right)$$

$$h \leq \left(b - \frac{d}{2}\right) \mu_s$$

$$b \geq \frac{h}{\mu_s} + \frac{d}{2}$$

$$b = \frac{h}{\mu_s} + \frac{d}{2} \quad \text{Ans}$$

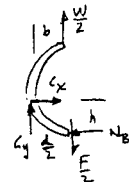

8-21. Determine the maximum weight W the man can lift with constant velocity using the pulley system, without and then with the "leading block" or pulley at A . The man has a weight of 200 lb and the coefficient of static friction between his feet and the ground is $\mu_s = 0.6$.

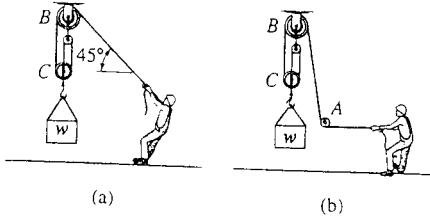

(a)

$$+\uparrow \Sigma F_y = 0; \quad \frac{W}{3} \sin 45^\circ + N - 200 = 0$$

$$\rightarrow \Sigma F_x = 0; \quad -\frac{W}{3} \cos 45^\circ + 0.6N = 0$$

$$W = 318 \text{ lb} \quad \text{Ans}$$

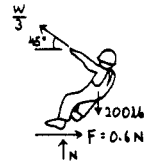

(b)

$$+\uparrow \Sigma F_y = 0; \quad N = 200 \text{ lb}$$

$$\rightarrow \Sigma F_x = 0; \quad 0.6(200) = \frac{W}{3}$$

$$W = 360 \text{ lb} \quad \text{Ans}$$

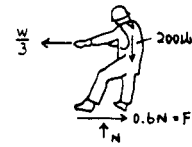

8-22. The uniform dresser has a weight of 90 lb and rests on a tile floor for which $\mu_s = 0.25$. If the man pushes on it in the horizontal direction $\theta = 0^\circ$, determine the smallest magnitude of force F needed to move the dresser. Also, if the man has a weight of 150 lb, determine the smallest coefficient of static friction between his shoes and the floor so that he does not slip.

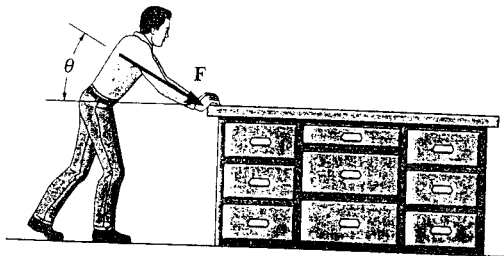

Dresser:

$$+\uparrow \Sigma F_y = 0; \quad N_D - 90 = 0$$

$$N_D = 90 \text{ lb}$$

$$\rightarrow \Sigma F_x = 0; \quad F - 0.25(90) = 0$$

$$F = 22.5 \text{ lb} \quad \text{Ans}$$

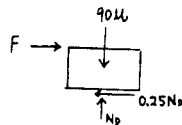

Man:

$$+\uparrow \Sigma F_y = 0; \quad N_m - 150 = 0$$

$$N_m = 150 \text{ lb}$$

$$\rightarrow \Sigma F_x = 0; \quad -22.5 + \mu_m(150) = 0$$

$$\mu_m = 0.15 \quad \text{Ans}$$

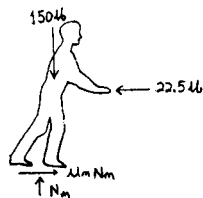

8-23. The uniform dresser has a weight of 90 lb and rests on a tile floor for which $\mu_s = 0.25$. If the man pushes on it in the direction $\theta = 30^\circ$, determine the smallest magnitude of force F needed to move the dresser. Also, if the man has a weight of 150 lb, determine the smallest coefficient of static friction between his shoes and the floor so that he does not slip.

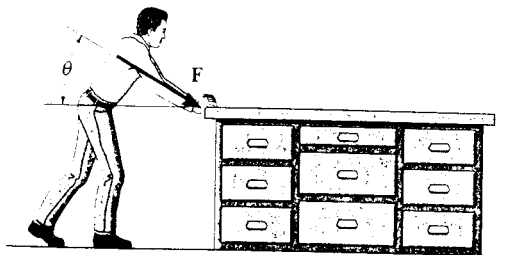

Dresser :

$$+\uparrow \Sigma F_y = 0; \quad N - 90 - F \sin 30^\circ = 0$$

$$\rightarrow \Sigma F_x = 0; \quad F \cos 30^\circ - 0.25 N = 0$$

$$N = 105.1 \text{ lb}$$

$$F = 30.363 \text{ lb} = 30.4 \text{ lb} \quad \text{Ans}$$

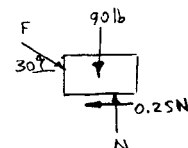

Man :

$$+\uparrow \Sigma F_y = 0; \quad N_m - 150 + 30.363 \sin 30^\circ = 0$$

$$\rightarrow \Sigma F_x = 0; \quad F_m - 30.363 \cos 30^\circ = 0$$

$$N_m = 134.82 \text{ lb}$$

$$F_m = 26.295 \text{ lb}$$

$$\mu_m = \frac{F_m}{N_m} = \frac{26.295}{134.82} = 0.195 \quad \text{Ans}$$

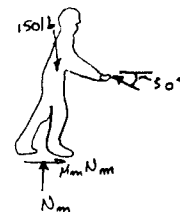

*8-24. The 5-kg cylinder is suspended from two equal-length cords. The end of each cord is attached to a ring of negligible mass, which passes along a horizontal shaft. If the coefficient of static friction between each ring and the shaft is $\mu_s = 0.5$, determine the greatest distance d by which the rings can be separated and still support the cylinder.

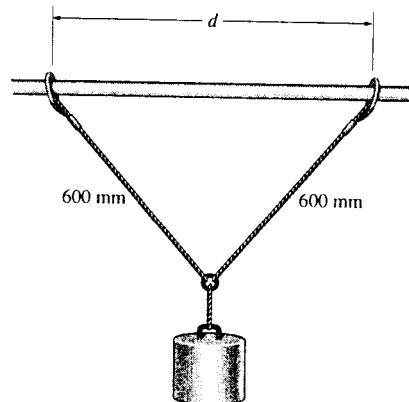

Friction : When the ring is on the verge to sliding along the rod, slipping will have to occur. Hence, $F = \mu N = 0.5N$. From the force diagram (T is the tension developed by the cord)

$$\tan \theta = \frac{N}{0.5N} = 2 \quad \theta = 63.43^\circ$$

Geometry :

$$d = 2(600 \cos 63.43^\circ) = 537 \text{ mm}$$

Ans

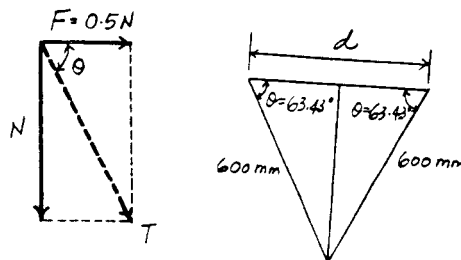

8-25. The board can be adjusted vertically by tilting it up and sliding the smooth pin A along the vertical guide G . When placed horizontally, the bottom C then bears along the edge of the guide, where $\mu_s = 0.4$. Determine the largest dimension d which will support any applied force F without causing the board to slip downward.

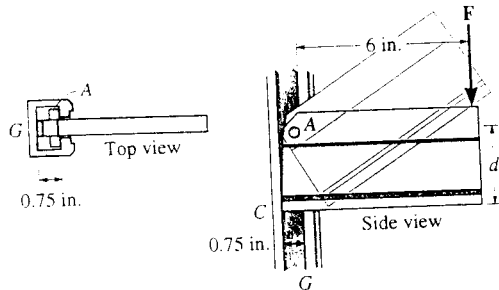

$$\begin{aligned}
 +\uparrow \Sigma F_y &= 0; & 0.4N_C - F &= 0 \\
 \curvearrowleft +\Sigma M_A &= 0; & -F(6) + d(N_C) - 0.4N_C(0.75) &= 0 \\
 \text{Thus,} & & -0.4N_C(6) + d(N_C) - 0.4N_C(0.75) &= 0 \\
 & & d &= 2.70 \text{ in.} \quad \text{Ans}
 \end{aligned}$$

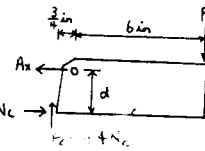

8-26. The homogeneous semicylinder has a mass m and mass center at G . Determine the largest angle θ of the inclined plane upon which it rests so that it does not slip down the plane. The coefficient of static friction between the plane and the cylinder is $\mu_s = 0.3$. Also, what is the angle ϕ for this case?

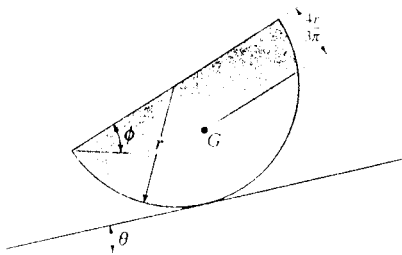

The semi cylinder is a two-force member :

$$\text{Since } F = \mu N$$

$$\tan \theta = \frac{\mu N}{N} = \mu$$

$$\theta = \tan^{-1} 0.3 = 16.7^\circ \quad \text{Ans}$$

$$\frac{r}{\sin(180^\circ - \phi)} = \frac{\frac{4r}{3\pi}}{\sin 16.7^\circ}$$

$$0.6771 = \sin \phi$$

$$\phi = 42.6^\circ \quad \text{Ans}$$

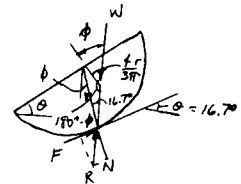

8-27. Car A has a mass of 1.4 Mg and mass center at G. If car B exerts a horizontal force on A of 2 kN, determine if this force is great enough to move car A. The coefficients of static and kinetic friction between the tires and the road are $\mu_s = 0.5$ and $\mu_k = 0.35$. Assume B's bumper is smooth.

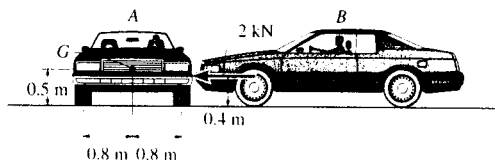

Slipping :

$$\rightarrow \Sigma F_x = 0; \quad F - 2 = 0$$

$$F = 2 \text{ kN}$$

$$+\uparrow \Sigma F_y = 0; \quad N_A = 13.734 \text{ kN}$$

$$F_{max} = 0.5(13.734) = 6.867 \text{ kN} > 2 \text{ kN}$$

Tipping :

$$(+\Sigma M_C = 0; \quad 2(0.5) < 13.734(0.8)$$

$$1 < 10.99$$

Therefore car A will not move. **Ans**

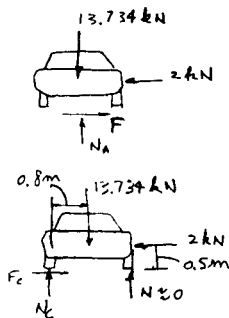

*8-28. A 35-kg disk rests on an inclined surface for which $\mu_s = 0.2$. Determine the maximum vertical force P that may be applied to link AB without causing the disk to slip at C .

Equations of Equilibrium: From FBD (a),

$$\left(+ \Sigma M_B = 0; \quad P(600) - A_y(900) = 0 \quad A_y = 0.6667P \right)$$

From FBD (b),

$$+ \uparrow \Sigma F_y = 0 \quad N_C \sin 60^\circ - F_C \sin 30^\circ - 0.6667P - 343.35 = 0 \quad [1]$$

$$\left(+ \Sigma M_O = 0; \quad F_C(200) - 0.6667P(200) = 0 \quad [2] \right)$$

Friction: If the disk is on the verge of moving, slipping would have to occur at point C . Hence, $F_C = \mu_s N_C = 0.2N_C$. Substituting this value into Eqs. [1] and [2] and solving, we have

$$\begin{aligned} P &= 182 \text{ N} & \text{Ans} \\ N_C &= 606.60 \text{ N} \end{aligned}$$

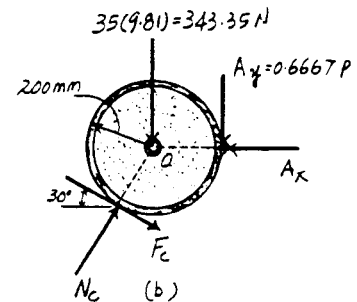
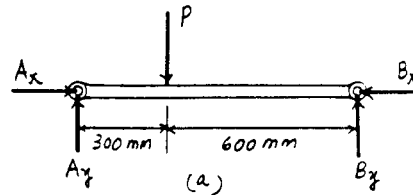
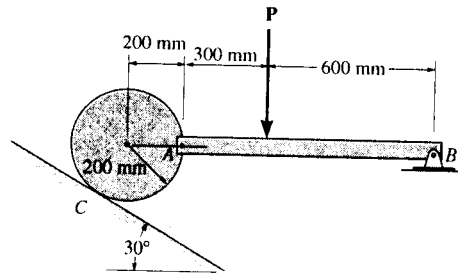

8-29. The crate has a W and the coefficient of static friction at the surface is $\mu_s = 0.3$. Determine the orientation of the cord and the smallest possible force P that has to be applied to the cord so that the crate is on the verge of moving.

Equations of Equilibrium:

$$+ \uparrow \Sigma F_y = 0; \quad N + P \sin \theta - W = 0 \quad [1]$$

$$\rightarrow \Sigma F_x = 0; \quad P \cos \theta - F = 0 \quad [2]$$

Friction: If the crate is on the verge of moving, slipping will have to occur. Hence, $F = \mu_s N = 0.3N$. Substituting this value into Eqs. [1] and [2] and solving, we have

$$P = \frac{0.3W}{\cos \theta + 0.3 \sin \theta} \quad N = \frac{W \cos \theta}{\cos \theta + 0.3 \sin \theta}$$

In order to obtain the minimum P , $\frac{dP}{d\theta} = 0$.

$$\begin{aligned} \frac{dP}{d\theta} &= 0.3W \left[\frac{\sin \theta - 0.3 \cos \theta}{(\cos \theta + 0.3 \sin \theta)^2} \right] = 0 \\ \sin \theta - 0.3 \cos \theta &= 0 \\ \theta &= 16.70^\circ = 16.7^\circ \end{aligned}$$

Ans

$$\frac{d^2P}{d\theta^2} = 0.3W \left[\frac{(\cos \theta + 0.3 \sin \theta)^2 + 2(\sin \theta - 0.3 \cos \theta)^2}{(\cos \theta + 0.3 \sin \theta)^3} \right]$$

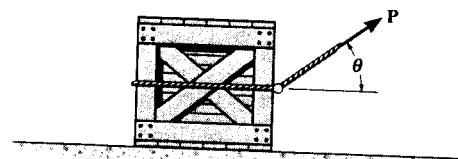

[1]

[2] At $\theta = 16.70^\circ$, $\frac{d^2P}{d\theta^2} = 0.2873W > 0$. Thus, $\theta = 16.70^\circ$ will result in a minimum P .

$$P = \frac{0.3W}{\cos 16.70^\circ + 0.3 \sin 16.70^\circ} = 0.287W \quad \text{Ans}$$

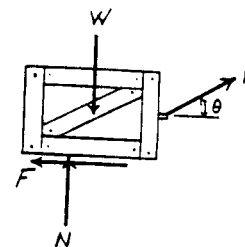

8-30. The 800-lb concrete pipe is being lowered from the truck bed when it is in the position shown. If the coefficient of static friction at the points of support A and B is $\mu_s = 0.4$, determine where it begins to slip first: at A or B , or both at A and B .

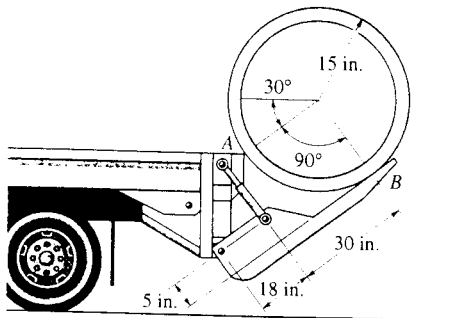

$$\Sigma F_x = 0; \quad N_A + F_B - 800 \sin 30^\circ = 0$$

$$\Sigma F_y = 0; \quad F_A + N_B - 800 \cos 30^\circ = 0$$

$$(+\Sigma M_O = 0; \quad F_B(15) - F_A(15) = 0$$

$$F_A = F_B$$

Assume slipping at A :

$$F_A = 0.4 N_A$$

Thus,

$$N_A = 285.71 \text{ lb}$$

$$N_B = 578.53 \text{ lb}$$

$$F_A = F_B = 114.29 \text{ lb}$$

At B :

$$(F_B)_{\max} = 0.4 N_B = 0.4(578.53) = 231.4 \text{ lb} > 114.29 \text{ lb} \quad (\text{O.K.})$$

Thus, slipping occurs at A . **Ans**

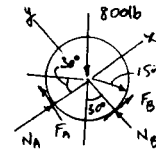

8-31. The friction pawl is pinned at A and rests against the wheel at B . It allows freedom of movement when the wheel is rotating counterclockwise about C . Clockwise rotation is prevented due to friction of the pawl which tends to bind the wheel. If $(\mu_s)_B = 0.6$, determine the design angle θ which will prevent clockwise motion for any value of applied moment M . *Hint:* Neglect the weight of the pawl so that it becomes a two-force member.

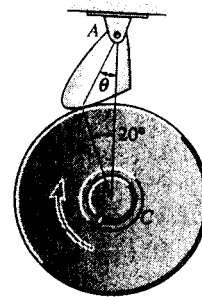

Friction: When the wheel is on the verge of rotating, slipping would have to occur. Hence, $F_B = \mu N_B = 0.6 N_B$. From the force diagram (F_{AB} is the force developed in the two force member AB)

$$\tan(20^\circ + \theta) = \frac{0.6 N_B}{N_B} = 0.6$$

$$\theta = 11.0^\circ$$

Ans

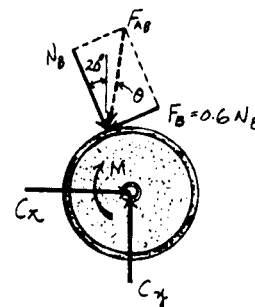

***8-32.** The semicylinder of mass m and radius r lies on the rough inclined plane for which $\phi = 10^\circ$ and the coefficient of static friction is $\mu_s = 0.3$. Determine if the semicylinder slides down the plane, and if not, find the angle of tip θ of its base AB .

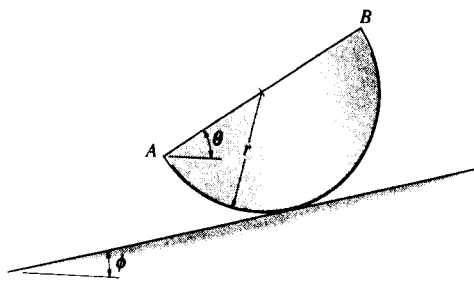

Equations of Equilibrium :

$$\left(+ \Sigma M_O = 0; \quad F(r) - 9.81m \sin \theta \left(\frac{4r}{3\pi} \right) = 0 \right. \quad [1]$$

$$\left(\rightarrow \Sigma F_x = 0; \quad F \cos 10^\circ - N \sin 10^\circ = 0 \right. \quad [2]$$

$$\left(+ \uparrow \Sigma F_y = 0 \quad F \sin 10^\circ + N \cos 10^\circ - 9.81m = 0 \right. \quad [3]$$

Solving Eqs. [1], [2] and [3] yields

$$N = 9.661m \quad F = 1.703m \quad \theta = 24.2^\circ \quad \text{Ans}$$

Friction : The maximum friction force that can be developed between the semicylinder and the inclined plane is $(F)_{\max} = \mu N = 0.3(9.661m) = 2.898m$. Since $F_{\max} > F = 1.703m$, the semicylinder will not slide down the plane. Ans

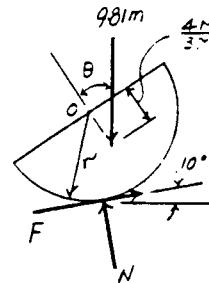

8-33. The semicylinder of mass m and radius r lies on the rough inclined plane. If the inclination $\phi = 15^\circ$, determine the smallest coefficient of static friction which will prevent the semicylinder from slipping.

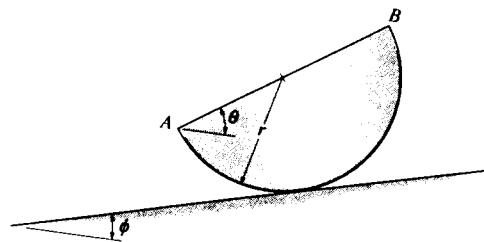

Equations of Equilibrium :

$$\left(+ \Sigma F_x = 0; \quad F - 9.81m \sin 15^\circ = 0 \quad F = 2.539m \right.$$

$$\left(+ \Sigma F_y = 0; \quad N - 9.81m \cos 15^\circ = 0 \quad N = 9.476m \right.$$

Friction : If the semicylinder is on the verge of moving, slipping would have to occur. Hence,

$$F = \mu_s N$$

$$2.539m = \mu_s (9.476m)$$

$$\mu_s = 0.268 \quad \text{Ans}$$

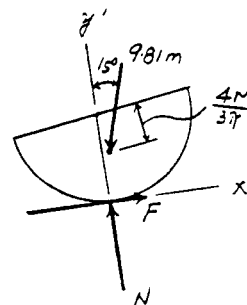

8-34. The door brace AB is to be designed to prevent opening the door. If the brace forms a pin connection under the doorknob and the coefficient of static friction with the floor is $\mu_s = 0.5$, determine the largest length L the brace can have to prevent the door from being opened. Neglect the weight of the brace.

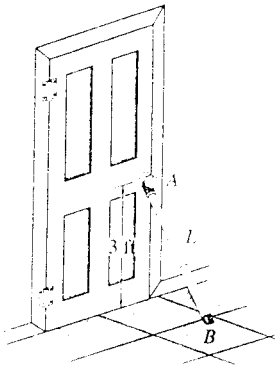

The brace is a two-force member.

$$\frac{0.5N}{N} = \frac{\sqrt{L^2 - (3)^2}}{3}$$

$$1.5 = \frac{\sqrt{L^2 - (3)^2}}{3}$$

$$L = 3.35 \text{ ft} \quad \text{Ans}$$

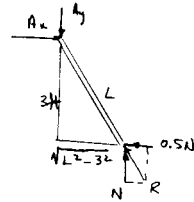

8-35. The man has a weight of 200 lb, and the coefficient of static friction between his shoes and the floor is $\mu_s = 0.5$. Determine where he should position his center of gravity G at d in order to exert the maximum horizontal force on the door. What is this force?

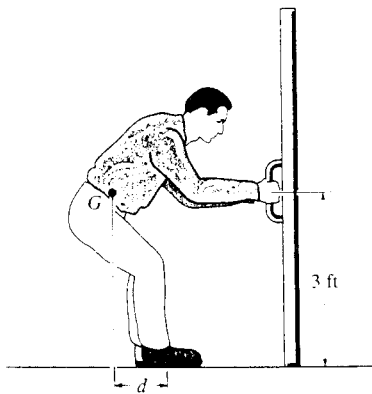

$$F_{max} = 0.5N = 0.5(200) = 100 \text{ lb}$$

$$\rightarrow \Sigma F_x = 0; \quad P - 100 = 0; \quad P = 100 \text{ lb} \quad \text{Ans}$$

$$\curvearrowleft + \Sigma M_O = 0; \quad 200(d) - 100(3) = 0$$

$$d = 1.50 \text{ ft} \quad \text{Ans}$$

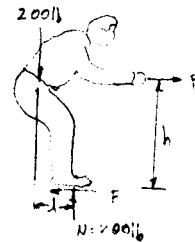

***8-36.** The 80-lb boy stands on the beam and pulls on the cord with a force large enough to just cause him to slip. If $(\mu_s)_D = 0.4$ between his shoes and the beam, determine the reactions at A and B . The beam is uniform and has a weight of 100 lb. Neglect the size of the pulleys and the thickness of the beam.

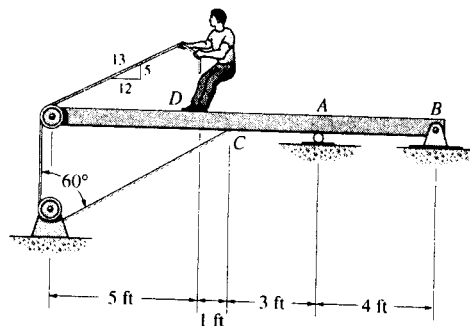

Equations of Equilibrium and Friction: When the boy is on the verge to slipping, then $F_D = (\mu_s)_D N_D = 0.4N_D$. From FBD (a),

$$+\uparrow \Sigma F_y = 0; \quad N_D - T\left(\frac{5}{13}\right) - 80 = 0 \quad [1]$$

$$\rightarrow \Sigma F_x = 0; \quad 0.4N_D - T\left(\frac{12}{13}\right) = 0 \quad [2]$$

Solving Eqs. [1] and [2] yields

$$T = 41.6 \text{ lb} \quad N_D = 96.0 \text{ lb}$$

Hence, $F_D = 0.4(96.0) = 38.4 \text{ lb}$. From FBD (b),

$$\begin{aligned} (+\Sigma M_B = 0; \quad 100(6.5) + 96.0(8) - 41.6\left(\frac{5}{13}\right)(13) \\ + 41.6(13) + 41.6\sin 30^\circ(7) - A_y(4) = 0 \\ A_y = 474.1 \text{ lb} = 474 \text{ lb} \end{aligned} \quad \text{Ans}$$

$$\begin{aligned} \rightarrow \Sigma F_x = 0; \quad B_x + 41.6\left(\frac{12}{13}\right) - 38.4 - 41.6\cos 30^\circ = 0 \\ B_x = 36.0 \text{ lb} \end{aligned} \quad \text{Ans}$$

$$\begin{aligned} +\uparrow \Sigma F_y = 0; \quad 474.1 + 41.6\left(\frac{5}{13}\right) - 41.6 \\ - 41.6\sin 30^\circ - 96.0 - 100 - B_y = 0 \\ B_y = 231.7 \text{ lb} = 232 \text{ lb} \end{aligned} \quad \text{Ans}$$

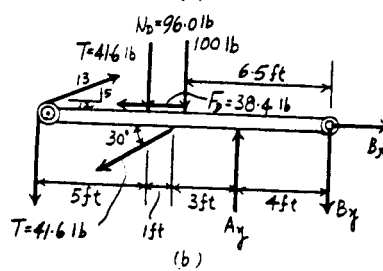
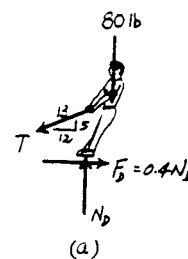

8-37. The 80-lb boy stands on the beam and pulls with a force of 40 lb. If $(\mu_s)_D = 0.4$, determine the frictional force between his shoes and the beam and the reactions at A and B. The beam is uniform and has a weight of 100 lb. Neglect the size of the pulleys and the thickness of the beam.

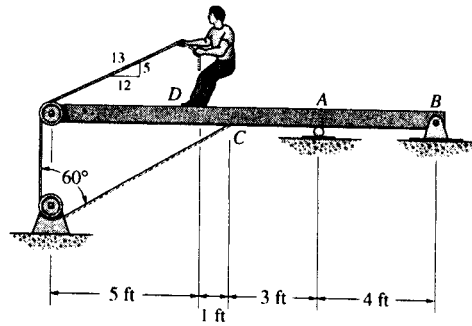

Equations of Equilibrium and Friction : From FBD (a).

$$+\uparrow \Sigma F_y = 0; \quad N_D - 40\left(\frac{5}{13}\right) - 80 = 0 \quad N_D = 95.38 \text{ lb}$$

$$\rightarrow \Sigma F_x = 0; \quad F_D - 40\left(\frac{12}{13}\right) = 0 \quad F_D = 36.92 \text{ lb}$$

Since $(F_D)_{\max} = (\mu_s)N_D = 0.4(95.38) = 38.15 \text{ lb} > F_D$, then the boy does not slip. Therefore, the friction force developed is

$$F_D = 36.92 \text{ lb} = 36.9 \text{ lb}$$

From FBD (b),

$$\begin{aligned} (+\Sigma M_B = 0; \quad & 100(6.5) + 95.38(8) - 40\left(\frac{5}{13}\right)(13) \\ & + 40(13) + 40\sin 30^\circ(7) - A_y(4) = 0 \\ & A_y = 468.27 \text{ lb} = 468 \text{ lb} \end{aligned}$$

$$\begin{aligned} \rightarrow \Sigma F_x = 0; \quad & B_x + 40\left(\frac{12}{13}\right) - 36.92 - 40\cos 30^\circ = 0 \\ & B_x = 34.64 \text{ lb} = 34.6 \text{ lb} \end{aligned}$$

$$\begin{aligned} +\uparrow \Sigma F_y = 0; \quad & 468.27 + 40\left(\frac{5}{13}\right) - 40 \\ & - 40\sin 30^\circ - 95.38 - 100 - B_y = 0 \\ & B_y = 228.27 \text{ lb} = 228 \text{ lb} \end{aligned}$$

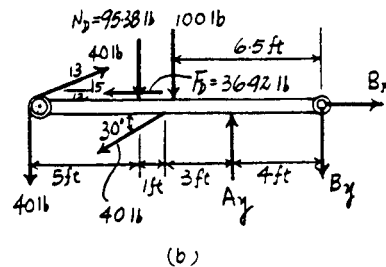
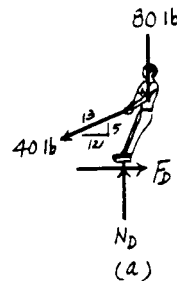

8-38. Two blocks *A* and *B* have a weight of 10 lb and 6 lb, respectively. They are resting on the incline for which the coefficients of static friction are $\mu_A = 0.15$ and $\mu_B = 0.25$. Determine the incline angle θ for which both blocks begin to slide. Also find the required stretch or compression in the connecting spring for this to occur. The spring has a stiffness of $k = 2$ lb/ft.

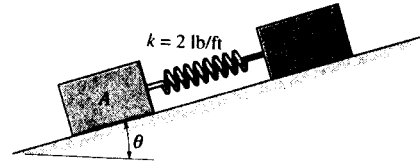

Equations of Equilibrium: Using the spring force formula, $F_{sp} = kx = 2x$. From FBD (a),

$$+\Sigma F_x = 0; \quad 2x + F_A - 10\sin\theta = 0 \quad [1]$$

$$+\Sigma F_y = 0; \quad N_A - 10\cos\theta = 0 \quad [2]$$

From FBD (b),

$$+\Sigma F_x = 0; \quad F_B - 2x - 6\sin\theta = 0 \quad [3]$$

$$+\Sigma F_y = 0; \quad N_B - 6\cos\theta = 0 \quad [4]$$

Friction: If block *A* and *B* are on the verge to move, slipping would have to occur at point *A* and *B*. Hence, $F_A = \mu_A N_A = 0.15N_A$ and $F_B = \mu_B N_B = 0.25N_B$. Substituting these values into Eqs. [1], [2], [3] and [4] and solving, we have

$$\theta = 10.6^\circ \quad x = 0.184 \text{ ft} \quad \text{Ans}$$

$$N_A = 9.829 \text{ lb} \quad N_B = 5.897 \text{ lb}$$

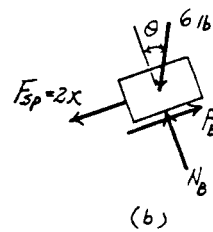
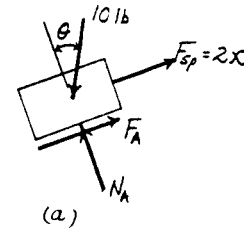

8-39. Two blocks *A* and *B* have a weight of 10 lb and 6 lb, respectively. They are resting on the incline for which the coefficients of static friction are $\mu_A = 0.15$ and $\mu_B = 0.25$. Determine the angle θ which will cause motion of one of the blocks. What is the friction force under each of the blocks when this occurs? The spring has a stiffness of $k = 2$ lb/ft and is originally unstretched.

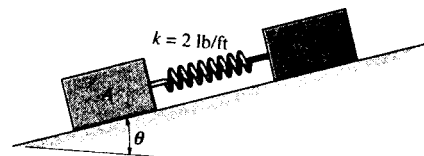

Equations of Equilibrium: Since Block *A* and *B* is either not moving or on the verge of moving, the spring force $F_{sp} = 0$. From FBD (a),

$$+\Sigma F_x = 0; \quad F_A - 10\sin\theta = 0 \quad [1]$$

$$+\Sigma F_y = 0; \quad N_A - 10\cos\theta = 0 \quad [2]$$

From FBD (b),

$$+\Sigma F_x = 0; \quad F_B - 6\sin\theta = 0 \quad [3]$$

$$+\Sigma F_y = 0; \quad N_B - 6\cos\theta = 0 \quad [4]$$

Friction: Assuming block *A* is on the verge of slipping, then

$$F_A = \mu_A N_A = 0.15N_A \quad [5]$$

Solving Eqs. [1], [2], [3], [4] and [5] yields

$$\theta = 8.531^\circ \quad N_A = 9.889 \text{ lb} \quad F_A = 1.483 \text{ lb}$$

$$F_B = 0.8900 \text{ lb} \quad N_B = 5.934 \text{ lb}$$

Since $(F_B)_{\max} = \mu_B N_B = 0.25(5.934) = 1.483 \text{ lb} > F_B$, block *B* does not slip. Therefore, the above assumption is correct. Thus

$$\theta = 8.53^\circ \quad F_A = 1.48 \text{ lb} \quad F_B = 0.890 \text{ lb} \quad \text{Ans}$$

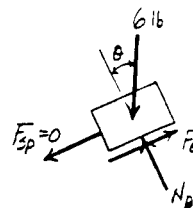
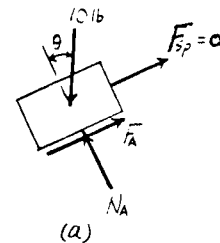

*8-40. Determine the smallest force the man must exert on the rope in order to move the 80-kg crate. Also, what is the angle θ at this moment? The coefficient of static friction between the crate and the floor is $\mu_s = 0.3$.

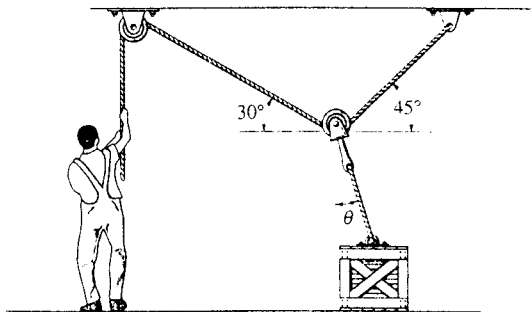

Crate:

$$\rightarrow \Sigma F_x = 0; \quad 0.3N_c - T' \sin \theta = 0 \quad (1)$$

$$+ \uparrow \Sigma F_y = 0; \quad N_c + T' \cos \theta - 80(9.81) = 0 \quad (2)$$

Pulley:

$$\rightarrow \Sigma F_x = 0; \quad -T \cos 30^\circ + T \cos 45^\circ + T' \sin \theta = 0$$

$$+ \uparrow \Sigma F_y = 0; \quad T \sin 30^\circ + T \sin 45^\circ - T' \cos \theta = 0$$

Thus,

$$T = 6.29253 T' \sin \theta$$

$$T = 0.828427 T' \cos \theta$$

$$\theta = \tan^{-1} \left(\frac{0.828427}{6.29253} \right) = 7.50^\circ \quad \text{Ans}$$

$$T = 0.82134 T' \quad (3)$$

From Eqs. (1) and (2),

$$N_c = 239 \text{ N}$$

$$T' = 550 \text{ N}$$

So that

$$T = 452 \text{ N} \quad \text{Ans}$$

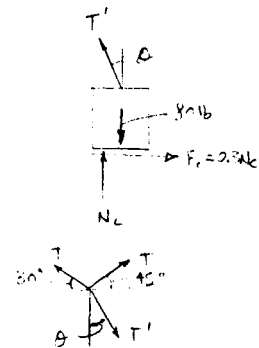

8-41. The three bars have a weight of $W_A = 20$ lb, $W_B = 40$ lb, and $W_C = 60$ lb, respectively. If the coefficients of static friction at the surfaces of contact are as shown, determine the smallest horizontal force P needed to move block A.

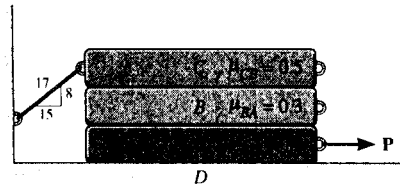

Equations of Equilibrium and Friction: If blocks A and B move together, then slipping will have to occur at the contact surfaces CB and AD. Hence, $F_{CB} = \mu_{s,CB} N_{CB} = 0.5N_{CB}$ and $F_{AD} = \mu_{s,AD} N_{AD} = 0.2N_{AD}$. From FBD (a)

$$+\uparrow \Sigma F_y = 0; \quad N_{CB} - T\left(\frac{8}{17}\right) - 60 = 0 \quad [1]$$

$$\rightarrow \Sigma F_x = 0; \quad 0.5N_{CB} - T\left(\frac{15}{17}\right) = 0 \quad [2]$$

and FBD (b)

$$+\uparrow \Sigma F_y = 0; \quad N_{AD} - N_{CB} - 60 = 0 \quad [3]$$

$$\rightarrow \Sigma F_x = 0; \quad P - 0.5N_{CB} - 0.2N_{AD} = 0 \quad [4]$$

Solving Eqs. [1], [2], [3] and [4] yields

$$T = 46.36 \text{ lb} \quad N_{CB} = 81.82 \text{ lb} \quad N_{AD} = 141.82 \text{ lb} \\ P = 69.27 \text{ lb}$$

If blocks A move only, then slipping will have to occur at contact surfaces BA and AD. Hence, $F_{BA} = \mu_{s,BA} N_{BA} = 0.3N_{BA}$ and $F_{AD} = \mu_{s,AD} N_{AD} = 0.2N_{AD}$. From FBD (c)

$$+\uparrow \Sigma F_y = 0; \quad N_{BA} - T\left(\frac{8}{17}\right) - 100 = 0 \quad [5]$$

$$\rightarrow \Sigma F_x = 0; \quad 0.3N_{BA} - T\left(\frac{15}{17}\right) = 0 \quad [6]$$

and FBD (d)

$$+\uparrow \Sigma F_y = 0; \quad N_{AD} - N_{BA} - 20 = 0 \quad [7]$$

$$\rightarrow \Sigma F_x = 0; \quad P - 0.3N_{BA} - 0.2N_{AD} = 0 \quad [8]$$

Solving Eqs. [5], [6], [7] and [8] yields

$$T = 40.48 \text{ lb} \quad N_{BA} = 119.05 \text{ lb} \quad N_{AD} = 139.05 \text{ lb} \\ P = 63.52 \text{ lb} = 63.5 \text{ lb (Control!)} \quad \mathbf{Ans}$$

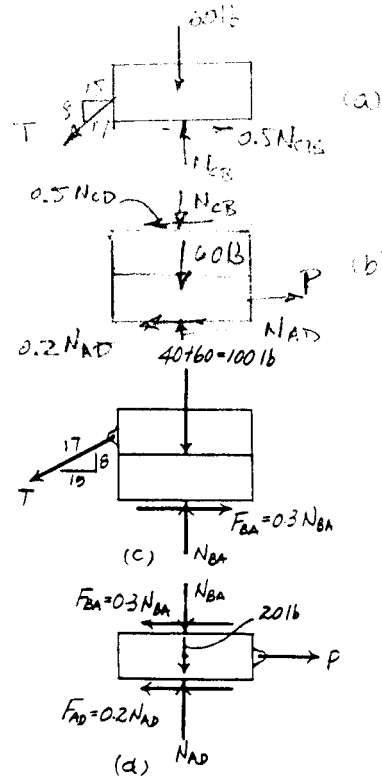

8-42. The friction hook is made from a fixed frame which is shown colored and a cylinder of negligible weight. A piece of paper is placed between the smooth wall and the cylinder. If $\theta = 20^\circ$, determine the smallest coefficient of static friction μ at all points of contact so that any weight W of paper p can be held.

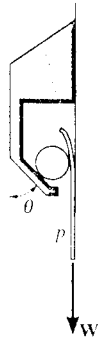

Paper:

$$+\uparrow \Sigma F_y = 0; \quad F = 0.5W$$

$$F = \mu N; \quad F = \mu N$$

$$N = \frac{0.5W}{\mu}$$

Cylinder:

$$\curvearrowleft + \Sigma M_O = 0; \quad F = 0.5W$$

$$\rightarrow \Sigma F_x = 0; \quad N \cos 20^\circ + F \sin 20^\circ - \frac{0.5W}{\mu} = 0$$

$$+\uparrow \Sigma F_y = 0; \quad N \sin 20^\circ - F \cos 20^\circ - 0.5W = 0$$

$$F = \mu N; \quad \mu^2 \sin 20^\circ + 2\mu \cos 20^\circ - \sin 20^\circ = 0$$

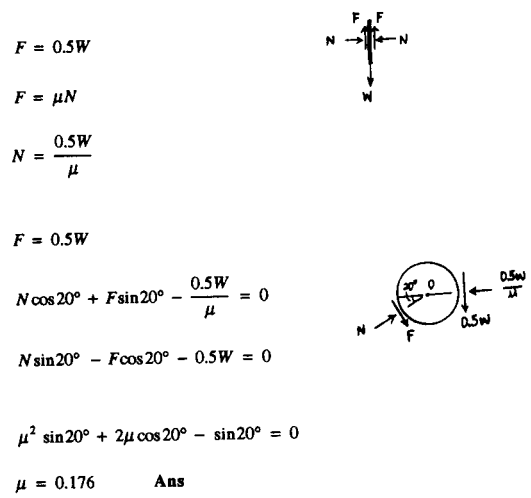

$\mu = 0.176$ **Ans**

8-43. The refrigerator has a weight of 180 lb and rests on a tile floor for which $\mu_s = 0.25$. If the man pushes horizontally on the refrigerator in the direction shown, determine the smallest magnitude of force needed to move it. Also, if the man has a weight of 150 lb, determine the smallest coefficient of friction between his shoes and the floor so that he does not slip.

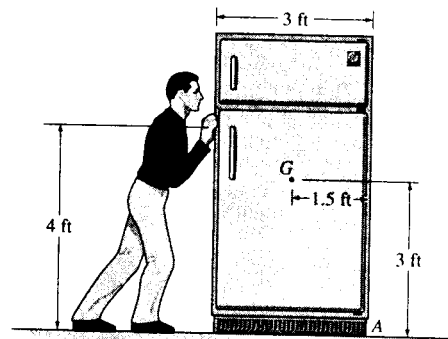

Equations of Equilibrium: From FBD (a),

$$+\uparrow \Sigma F_y = 0; \quad N - 180 = 0 \quad N = 180 \text{ lb}$$

$$\rightarrow \Sigma F_x = 0; \quad P - F = 0 \quad [1]$$

$$\curvearrowleft + \Sigma M_A = 0; \quad 180(x) - P(4) = 0 \quad [2]$$

Friction: Assuming the refrigerator is on the verge of slipping, then $F = \mu N = 0.25(180) = 45 \text{ lb}$. Substituting this value into Eqs. [1], and [2] and solving yields

$$P = 45.0 \text{ lb} \quad x = 1.00 \text{ ft}$$

Since $x < 1.5 \text{ ft}$, the refrigerator does not tip. Therefore, the above assumption is correct. Thus

$$P = 45.0 \text{ lb} \quad \text{Ans}$$

From FBD (b),

$$+\uparrow \Sigma F_y = 0; \quad N_m - 150 = 0 \quad N_m = 150 \text{ lb}$$

$$\rightarrow \Sigma F_x = 0; \quad F_m - 45.0 = 0 \quad F_m = 45.0 \text{ lb}$$

When the man is on the verge of slipping, then

$$F_m = \mu_s' N_m$$

$$45.0 = \mu_s' (150)$$

$$\mu_s' = 0.300 \quad \text{Ans}$$

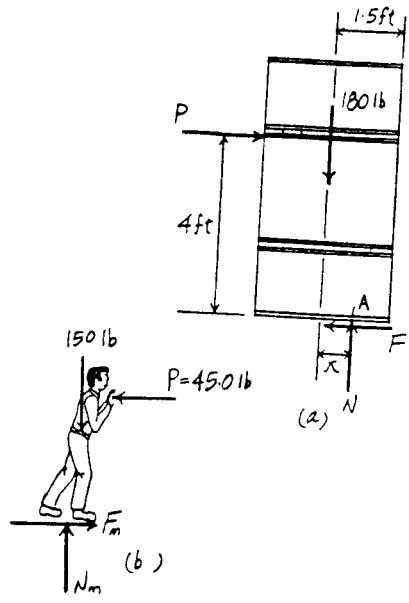

*8-44. The refrigerator has a weight of 180 lb and rests on a tile floor for which $\mu_s = 0.25$. Also, the man has a weight of 150 lb and the coefficient of static friction between the floor and his shoes is $\mu_s = 0.6$. If he pushes horizontally on the refrigerator, determine if he can move it. If so does the refrigerator slip or tip?

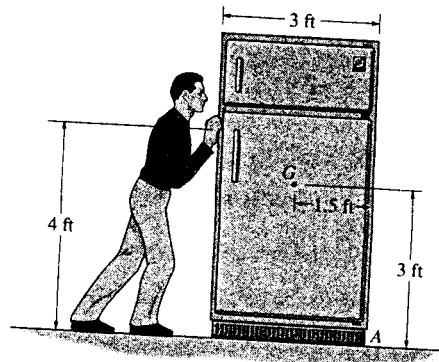

Equations of Equilibrium : From FBD (a),

$$\begin{aligned} +\uparrow \Sigma F_y = 0; \quad N - 180 = 0 \quad N = 180 \text{ lb} \\ \rightarrow \Sigma F_x = 0; \quad P - F = 0 \quad [1] \\ \curvearrowleft + \Sigma M_A = 0; \quad 180(x) - P(4) = 0 \quad [2] \end{aligned}$$

Friction : Assuming the refrigerator is on the verge of slipping, then $F = \mu N = 0.25(180) = 45 \text{ lb}$. Substituting this value into Eqs. [1], and [2] and solving yields

$$P = 45.0 \text{ lb} \quad x = 1.00 \text{ ft}$$

Since $x < 1.5 \text{ ft}$, the refrigerator does not tip. Therefore, the above assumption is correct. Thus, the refrigerator slips. **Ans**

From FBD (b),

$$\begin{aligned} +\uparrow \Sigma F_y = 0; \quad N_m - 150 = 0 \quad N_m = 150 \text{ lb} \\ \rightarrow \Sigma F_x = 0; \quad F_m - 45.0 = 0 \quad F_m = 45.0 \text{ lb} \end{aligned}$$

Since $(F_m)_{\max} = \mu_s N_m = 0.6(150) = 90.0 \text{ lb} > F_m$, then the man does not slip. Thus, The man is capable of moving the refrigerator. **Ans**

8-45. The wheel weighs 20 lb and rests on a surface for which $\mu_B = 0.2$. A cord wrapped around it is attached to the top of the 30-lb homogeneous block. If the coefficient of static friction at D is $\mu_D = 0.3$, determine the smallest vertical force that can be applied tangentially to the wheel which will cause motion to impend.

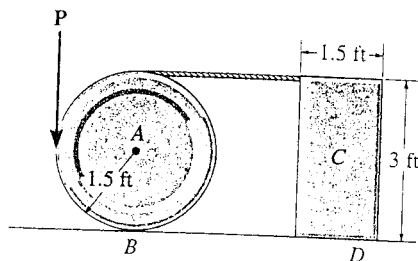

Cylinder A :
Assume slipping at B, $F_B = 0.2 N_B$

$$\begin{aligned} \curvearrowleft + \Sigma M_A = 0; \quad F_B + T = P \\ \rightarrow \Sigma F_x = 0; \quad F_B = T \\ +\uparrow \Sigma F_y = 0; \quad N_B = 20 + P \\ N_B = 20 + 2(0.2N_B) \\ N_B = 33.33 \text{ lb} \\ F_B = 6.67 \text{ lb} \\ T = 6.67 \text{ lb} \\ P = 13.3 \text{ lb} \quad \text{Ans} \end{aligned}$$

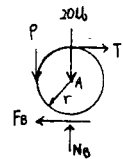

$$\begin{aligned} \rightarrow \Sigma F_x = 0; \quad F_D = 6.67 \text{ lb} \\ +\uparrow \Sigma F_y = 0; \quad N_D = 30 \text{ lb} \\ (F_D)_{\max} = 0.3(30) = 9 \text{ lb} > 6.67 \text{ lb} \quad (\text{O.K.}) \\ \text{(No slipping occurs)} \\ \curvearrowleft + \Sigma M_D = 0; \quad -30(x) + 6.67(3) = 0 \\ x = 0.667 \text{ ft} < \frac{1.5}{2} = 0.75 \text{ ft} \quad (\text{O.K.}) \\ \text{(No tipping occurs)} \end{aligned}$$

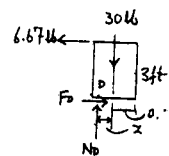

8-46. Each of the cylinders has a mass of 50 kg. If the coefficients of static friction at the points of contact are $\mu_A = 0.5$, $\mu_B = 0.5$, $\mu_C = 0.5$, and $\mu_D = 0.6$, determine the couple moment M needed to rotate cylinder E .

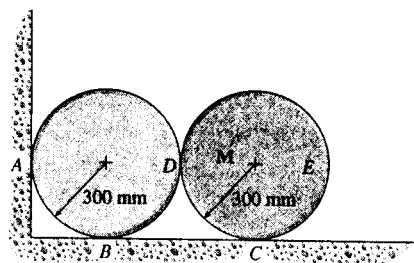

Equations of Equilibrium : From FBD (a),

$$\rightarrow \Sigma F_x = 0; \quad N_D - F_C = 0 \quad [1]$$

$$+\uparrow \Sigma F_y = 0 \quad N_C + F_D - 490.5 = 0 \quad [2]$$

$$\curvearrowright + \Sigma M_O = 0; \quad M - F_C(0.3) - F_D(0.3) = 0 \quad [3]$$

From FBD (b),

$$\rightarrow \Sigma F_x = 0; \quad N_A + F_B - N_D = 0 \quad [4]$$

$$+\uparrow \Sigma F_y = 0 \quad N_B - F_A - F_D - 490.5 = 0 \quad [5]$$

$$\curvearrowright + \Sigma M_P = 0; \quad F_A(0.3) + F_B(0.3) - F_D(0.3) = 0 \quad [6]$$

Friction : Assuming cylinder E slips at points C and D and cylinder F does not move, then $F_C = \mu_{C} N_C = 0.5 N_C$ and $F_D = \mu_{D} N_D = 0.6 N_D$. Substituting these values into Eqs. [1], [2] and [3] and solving, we have

$$\begin{aligned} N_C &= 377.31 \text{ N} & N_D &= 188.65 \text{ N} \\ M &= 90.55 \text{ N} \cdot \text{m} = 90.6 \text{ N} \cdot \text{m} \end{aligned} \quad \text{Ans}$$

If cylinder F is on the verge of slipping at point A , then $F_A = \mu_{A} N_A = 0.5 N_A$. Substitute this value into Eqs. [4], [5] and [6] and solving, we have

$$N_A = 150.92 \text{ N} \quad N_B = 679.15 \text{ N} \quad F_B = 37.73 \text{ N}$$

Since $(F_B)_{\max} = \mu_{B} N_B = 0.5(679.15) = 339.58 \text{ N} > F_B$, cylinder F does not move. Therefore the above assumption is correct.

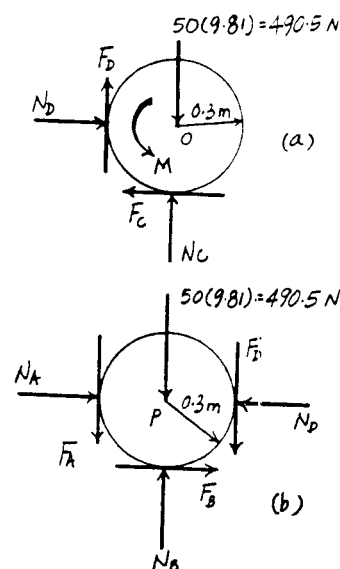

8-47. The beam AB has a negligible mass and thickness and is subjected to a triangular distributed loading. It is supported at one end by a pin and at the other end by a post having a mass of 50 kg and negligible thickness. Determine the minimum force P needed to move the post. The coefficients of static friction at B and C are $\mu_B = 0.4$ and $\mu_C = 0.2$, respectively.

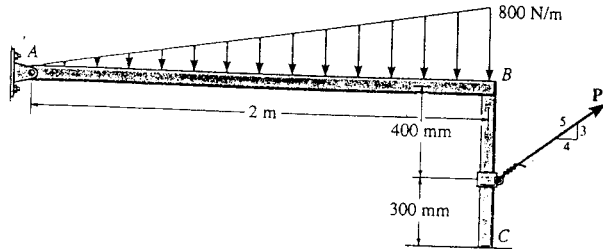

Member AB :

$$(+\Sigma M_A = 0; \quad -800\left(\frac{4}{3}\right) + N_B(2) = 0$$

$$N_B = 533.3 \text{ N}$$

Post :

Assume slipping occurs at C ; $F_C = 0.2 N_C$

$$(+\Sigma M_C = 0; \quad -\frac{4}{5}P(0.3) + F_B(0.7) = 0$$

$$\rightarrow \Sigma F_x = 0; \quad \frac{4}{5}P - F_B - 0.2N_C = 0$$

$$+\uparrow \Sigma F_y = 0; \quad \frac{3}{5}P + N_C - 533.3 - 50(9.81) = 0$$

$$P = 355 \text{ N} \quad \text{Ans}$$

$$N_C = 811.0 \text{ N}$$

$$F_B = 121.6 \text{ N}$$

$$(F_B)_{\max} = 0.4(533.3) = 213.3 \text{ N} > 121.6 \text{ N} \quad (\text{O.K.})$$

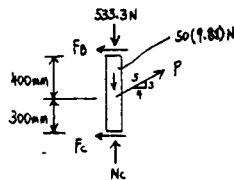
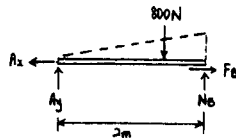

*8-48. The beam AB has a negligible mass and thickness and is subjected to a triangular distributed loading. It is supported at one end by a pin and at the other end by a post having a mass of 50 kg and negligible thickness. Determine the two coefficients of static friction at B and at C so that when the magnitude of the applied force is increased to $P = 150$ N, the post slips at both B and C simultaneously.

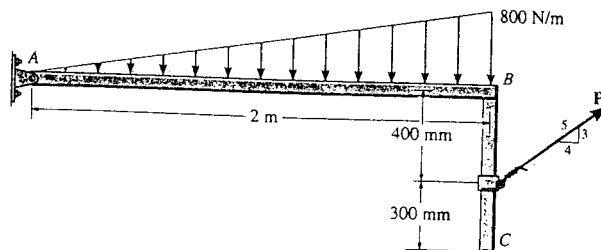

Member AB :

$$(+\Sigma M_A = 0; \quad -800\left(\frac{4}{3}\right) + N_B(2) = 0$$

$$N_B = 533.3 \text{ N}$$

Post :

$$+\uparrow \Sigma F_y = 0; \quad N_C - 533.3 + 150\left(\frac{3}{5}\right) = 0$$

$$N_C = 933.84 \text{ N}$$

$$(+\Sigma M_C = 0; \quad -\frac{4}{5}(150)(0.3) + F_B(0.7) = 0$$

$$F_B = 51.429 \text{ N}$$

$$+\rightarrow \Sigma F_x = 0; \quad \frac{4}{5}(150) - F_C - 51.429 = 0$$

$$F_C = 68.571 \text{ N}$$

$$\mu_C = \frac{F_C}{N_C} = \frac{68.571}{933.84} = 0.0734 \quad \text{Ans}$$

$$\mu_B = \frac{F_B}{N_B} = \frac{51.429}{533.3} = 0.0964 \quad \text{Ans}$$

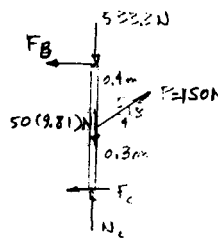
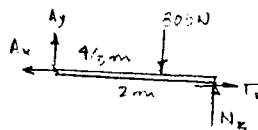

8-49. The block of weight W is being pulled up the inclined plane of slope α using a force \mathbf{P} . If \mathbf{P} acts at the angle ϕ as shown, show that for slipping to occur, $P = W \sin(\alpha + \theta) / \cos(\phi - \theta)$ where θ is the angle of friction; $\theta = \tan^{-1} \mu$.

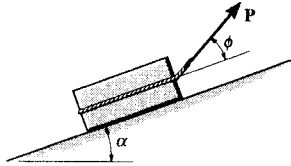

$$\uparrow + \Sigma F_x = 0; \quad P \cos \phi - W \sin \alpha - \mu N = 0$$

$$+ \uparrow \Sigma F_y = 0; \quad N - W \cos \alpha + P \sin \phi = 0$$

$$P \cos \phi - W \sin \alpha - \mu(W \cos \alpha - P \sin \phi) = 0$$

$$P = W \left(\frac{\sin \alpha + \mu \cos \alpha}{\cos \phi + \mu \sin \phi} \right)$$

Let $\mu = \tan \theta$

$$P = W \left(\frac{\sin(\alpha + \theta)}{\cos(\phi - \theta)} \right) \quad (\text{QED})$$

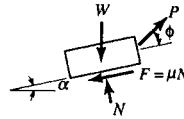

8-50. Determine the angle ϕ at which \mathbf{P} should act on the block so that the magnitude of \mathbf{P} is as small as possible to begin pushing the block up the incline. What is the corresponding value of P ? The block weighs W and the slope α is known.

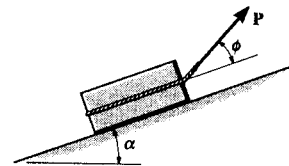

From Prob. 8-49:

$$P = W \left(\frac{\sin(\alpha + \theta)}{\cos(\phi - \theta)} \right)$$

$$\frac{dP}{d\phi} = W \left(\frac{\sin(\alpha + \theta) \sin(\phi - \theta)}{\cos^2(\phi - \theta)} \right) = 0$$

$$\sin(\alpha + \theta) \sin(\phi - \theta) = 0$$

$$\sin(\alpha + \theta) = 0 \quad \text{or} \quad \sin(\phi - \theta) = 0$$

$$\alpha = -\theta \quad \phi = \theta \quad \text{Ans}$$

$$P = W \sin(\alpha + \theta)$$

$$P = W \sin(\alpha + \phi) \quad \text{Ans}$$

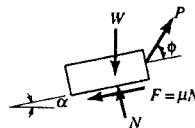

8-51. The beam AB has a negligible mass and thickness and is subjected to a force of 200 N. It is supported at one end by a pin and at the other end by a spool having a mass of 40 kg. If a cable is wrapped around the inner core of the spool, determine the minimum cable force P needed to move the spool. The coefficients of static friction at B and D are $\mu_B = 0.4$ and $\mu_D = 0.2$, respectively.

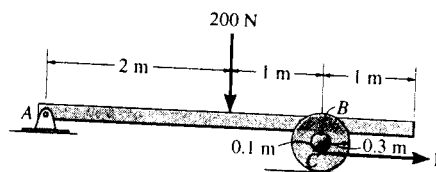

Equations of Equilibrium: From FBD (a),

$$\zeta + \Sigma M_A = 0; \quad N_B(3) - 200(2) = 0 \quad N_B = 133.33 \text{ N}$$

From FBD (b),

$$+\uparrow \Sigma F_y = 0 \quad N_D - 133.33 - 392.4 = 0 \quad N_D = 525.73 \text{ N}$$

$$\rightarrow \Sigma F_x = 0; \quad P - F_B - F_D = 0 \quad [1]$$

$$\zeta + \Sigma M_D = 0; \quad F_B(0.4) - P(0.2) = 0 \quad [2]$$

Friction: Assuming the spool slips at point B , then $F_B = \mu_B N_B = 0.4(133.33) = 53.33 \text{ N}$. Substituting this value into Eqs. [1] and [2] and solving, we have

$$F_D = 53.33 \text{ N} \\ P = 106.67 \text{ N} = 107 \text{ N} \quad \text{Ans}$$

Since $(F_D)_{\max} = \mu_D N_D = 0.2(525.73) = 105.15 \text{ N} > F_D$, the spool does not slip at point D . Therefore the above assumption is correct.

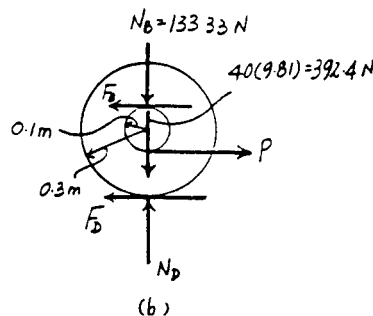
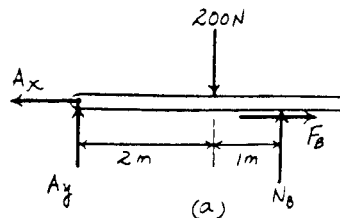

***8-52.** Block C has a mass of 50 kg and is confined between two walls by smooth rollers. If the block rests on top of the 40-kg spool, determine the minimum cable force P needed to move the spool. The cable is wrapped around the spool's inner core. The coefficients of static friction at A and B are $\mu_A = 0.3$ and $\mu_B = 0.6$.

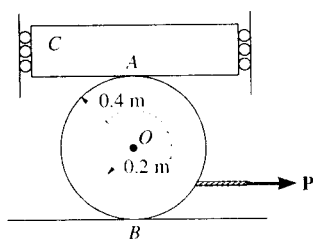

$$+\uparrow \Sigma F_y = 0; \quad N_B - 490.5 - 392.4 = 0$$

$$N_B = 882.9 \text{ N}$$

$$\zeta + \Sigma M_B = 0; \quad F_A(0.4) - F_B(0.4) + P(0.2) = 0$$

$$\rightarrow \Sigma F_x = 0; \quad -F_A + P - F_B = 0$$

Assume spool slips at A , then

$$F_A = 0.3(490.5) = 147.2 \text{ N}$$

Solving,

$$F_B = 441.4 \text{ N} \\ P = 589 \text{ N} \quad \text{Ans}$$

$$N_B = 882.9 \text{ N}$$

$$\text{Since } (F_B)_{\max} = 0.6(882.9) = 529.7 \text{ N} > 441.4 \text{ N} \quad (\text{O.K!})$$

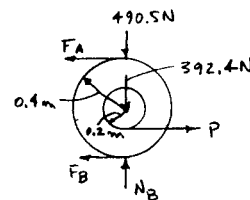

8-53. The uniform 60-kg crate C rests uniformly on a 10-kg dolly D . If the front casters of the dolly at A are locked to prevent rolling while the casters at B are free to roll, determine the maximum force P that may be applied without causing motion of the crate. The coefficient of static friction between the casters and the floor is $\mu_f = 0.35$ and between the dolly and the crate, $\mu_d = 0.5$.

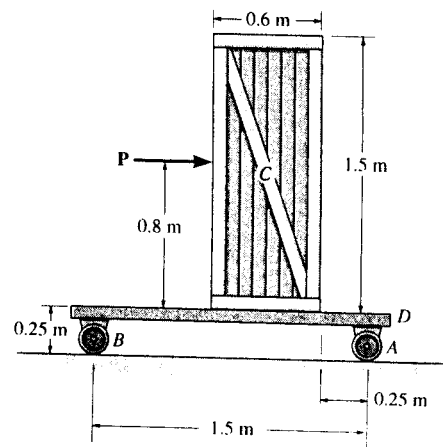

Equations of Equilibrium: From FBD (a),

$$+\uparrow \Sigma F_y = 0; \quad N_d - 588.6 = 0 \quad N_d = 588.6 \text{ N}$$

$$\rightarrow \Sigma F_x = 0; \quad P - F_d = 0 \quad [1]$$

$$\curvearrowleft + \Sigma M_A = 0; \quad 588.6(x) - P(0.8) = 0 \quad [2]$$

From FBD (b),

$$+\uparrow \Sigma F_y = 0 \quad N_B + N_A - 588.6 - 98.1 = 0 \quad [3]$$

$$\rightarrow \Sigma F_x = 0; \quad P - F_A = 0 \quad [4]$$

$$\curvearrowleft + \Sigma M_B = 0; \quad N_A(1.5) - P(1.05) - 588.6(0.95) - 98.1(0.75) = 0 \quad [5]$$

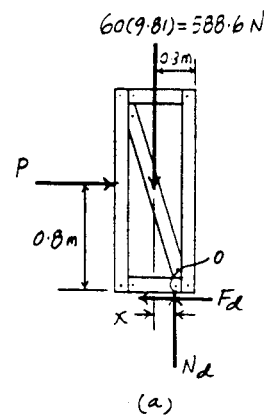

Friction: Assuming the crate slips on dolly, then $F_d = \mu_d N_d = 0.5(588.6) = 294.3 \text{ N}$. Substituting this value into Eqs. [1] and [2] and solving, we have

$$P = 294.3 \text{ N} \quad x = 0.400 \text{ m}$$

Since $x > 0.3 \text{ m}$, the crate tips on the dolly. If this is the case $x = 0.3 \text{ m}$. Solving Eqs. [1] and [2] with $x = 0.3 \text{ m}$ yields

$$P = 220.725 \text{ N} = 221 \text{ N}$$

$$F_d = 220.725 \text{ N}$$

Assuming the dolly slips at A , then $F_A = \mu_f N_A = 0.35 N_A$. Substituting this value into Eqs. [3], [4] and [5] and solving, we have

$$N_A = 559 \text{ N} \quad N_B = 128 \text{ N}$$

$$P = 195.6 \text{ N} = 196 \text{ N (Control!)}$$

Ans

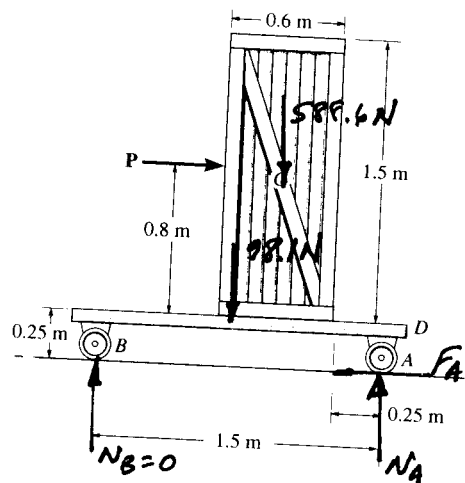

8-54. Two blocks A and B, each having a mass of 6 kg, are connected by the linkage shown. If the coefficients of static friction at the contacting surfaces are $\mu_A = 0.2$ and $\mu_B = 0.8$, determine the largest vertical force P that may be applied to pin C without causing the blocks to slip. Neglect the weight of the links.

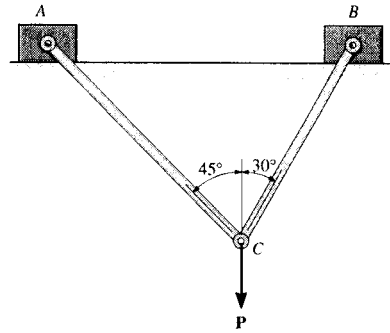

Equations of Equilibrium: From FBD (a),

$$+\uparrow \Sigma F_{x'} = 0; \quad T_B \cos 15^\circ - P \sin 45^\circ = 0 \quad T_B = 0.7321 P$$

$$+\rightarrow \Sigma F_{y'} = 0; \quad T_A + 0.7321 P \sin 15^\circ - P \cos 45^\circ = 0$$

$$T_A = 0.5176 P$$

From FBD (b),

$$+\uparrow \Sigma F_y = 0; \quad N_A - 0.5176 P \sin 45^\circ - 58.86 = 0 \quad [1]$$

$$\rightarrow \Sigma F_x = 0; \quad 0.5176 P \cos 45^\circ - F_A = 0 \quad [2]$$

From FBD (c),

$$+\uparrow \Sigma F_y = 0; \quad N_B - 0.7321 P \sin 60^\circ - 58.86 = 0 \quad [3]$$

$$\rightarrow \Sigma F_x = 0; \quad F_B - 0.7321 P \cos 60^\circ = 0 \quad [4]$$

Friction: Assuming block A slips, then $F_A = \mu_{sA} N_A = 0.2 N_A$. Substituting this value into Eqs. [1], [2], [3] and [4] and solving, we have

$$P = 40.20 \text{ N} = 40.2 \text{ N} \quad \text{Ans}$$

$$N_A = 73.575 \text{ N} \quad N_B = 84.35 \text{ N} \quad F_B = 14.715 \text{ N}$$

Since $(F_B)_{\max} = \mu_{sB} N_B = 0.8(84.35) = 67.48 \text{ N} > F_B$, block B does not slip. Therefore, the above assumption is correct.

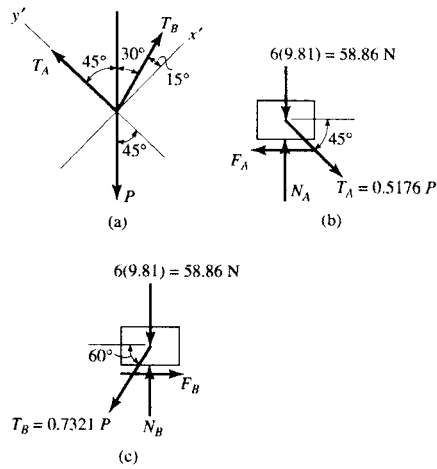

8-55. The uniform beam has a weight W and length 4a. It rests on the fixed rails at A and B. If the coefficient of static friction at the rails is μ_s , determine the horizontal force P, applied perpendicular to the face of the beam, which will cause the beam to move.

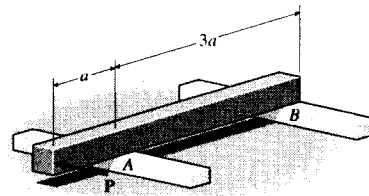

From FBD (a),

$$+\uparrow \Sigma F = 0; \quad N_A + N_B - W = 0$$

$$\curvearrowleft + \Sigma M_B = 0; \quad -N_A(3a) + W(2a) = 0$$

$$N_A = \frac{2}{3} W \quad N_B = \frac{1}{3} W$$

Support A can sustain twice as much static frictional force as support B.

From FBD (b),

$$+\uparrow \Sigma F = 0; \quad P + F_B - F_A = 0$$

$$\curvearrowleft + \Sigma M_B = 0; \quad -P(4a) + F_A(3a) = 0$$

$$F_A = \frac{4}{3} P \quad F_B = \frac{1}{3} P$$

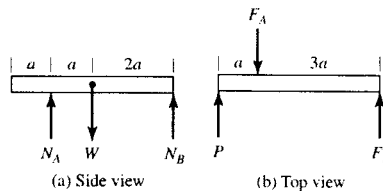

The frictional load at A is 4 times as great as at B. The beam will slip at A first.

$$P = \frac{3}{4} (F_A)_{\max} = \frac{3}{4} (\mu_s N_A) = \frac{1}{2} \mu_s W \quad \text{Ans}$$

***8-56.** The uniform 6-kg slender rod rests on the top center of the 3-kg block. If the coefficients of static friction at the points of contact are $\mu_A = 0.4$, $\mu_B = 0.6$, and $\mu_C = 0.3$, determine the largest couple moment M which can be applied to the rod without causing motion of the rod.

Equations of Equilibrium : From FBD (a),

$$\rightarrow \Sigma F_x = 0; \quad F_B - N_C = 0 \quad [1]$$

$$+\uparrow \Sigma F_y = 0; \quad N_B + F_C - 58.86 = 0 \quad [2]$$

$$+\Sigma M_B = 0; \quad F_C(0.6) + N_C(0.8) - M - 58.86(0.3) = 0 \quad [3]$$

From FBD (b),

$$+\uparrow \Sigma F_y = 0; \quad N_A - N_B - 29.43 = 0 \quad [4]$$

$$\rightarrow \Sigma F_x = 0; \quad F_A - F_B = 0 \quad [5]$$

$$+\Sigma M_O = 0; \quad F_B(0.3) - N_B(x) - 29.43(x) = 0 \quad [6]$$

Friction : Assume slipping occurs at point C and the block tips, then $F_C = \mu_C N_C = 0.3N_C$ and $x = 0.1$ m. Substituting these values into Eqs. [1], [2], [3], [4], [5] and [6] and solving, we have

$$M = 8.561 \text{ N} \cdot \text{m} = 8.56 \text{ N} \cdot \text{m} \quad \text{Ans}$$

$$N_B = 50.83 \text{ N} \quad N_A = 80.26 \text{ N} \quad F_A = F_B = N_C = 26.75 \text{ N}$$

Since $(F_A)_{\max} = \mu_A N_A = 0.4(80.26) = 32.11 \text{ N} > F_A$, the block does not slip. Also, $(F_B)_{\max} = \mu_B N_B = 0.6(50.83) = 30.50 \text{ N} > F_B$, then slipping does not occur at point B. Therefore, the above assumption is correct.

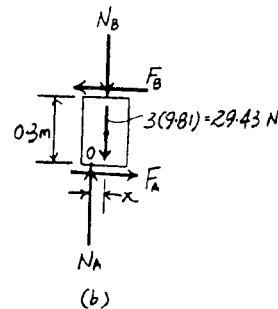
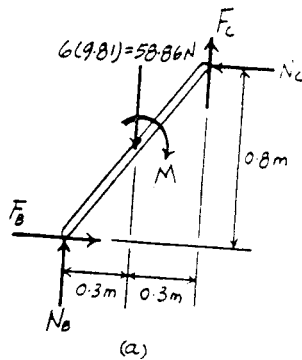
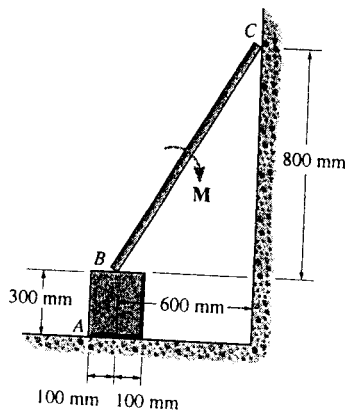

8-57. The carpenter slowly pushes the uniform board horizontally over the top of the saw horse. The board has a uniform weight of 3 lb/ft, and the saw horse has a weight of 15 lb and a center of gravity at G. Determine if the saw horse will stay in position, slip, or tip if the board is pushed forward when $d = 10$ ft. The coefficients of static friction are shown in the figure.

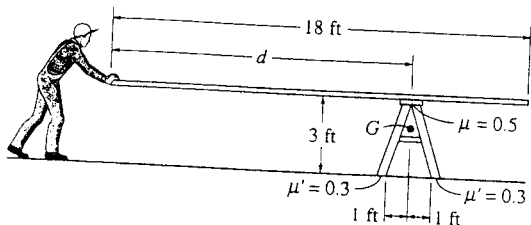

Board :

$$(+\Sigma M_p = 0; \quad -54(9) + N(10) = 0$$

$$N = 48.6 \text{ lb}$$

To cause slipping of board on saw horse :

$$P_x = F_{\max} = 0.5N = 24.3 \text{ lb}$$

Saw horse :

To cause slipping at ground :

$$P_x = F = F_{\max} = 0.3(48.6 + 15) = 19.08 \text{ lb}$$

To cause tipping :

$$(+\Sigma M_b = 0; \quad (48.6 + 15)(1) - P_x(3) = 0$$

$$P_x = 21.2 \text{ lb}$$

$$\text{Thus, } P_x = 19.1 \text{ lb} \quad \text{Ans}$$

The saw horse will start to slip.

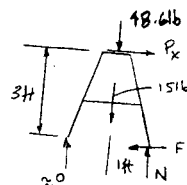
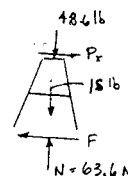
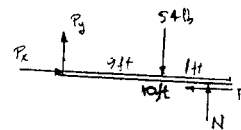

8-58. The carpenter slowly pushes the uniform board horizontally over the top of the saw horse. The board has a uniform weight of 3 lb/ft, and the saw horse has a weight of 15 lb and a center of gravity at G . Determine if the board will stay in position, slip, or tip if the board is pushed forward when $d = 14$ ft. The coefficients of static friction are shown in the figure.

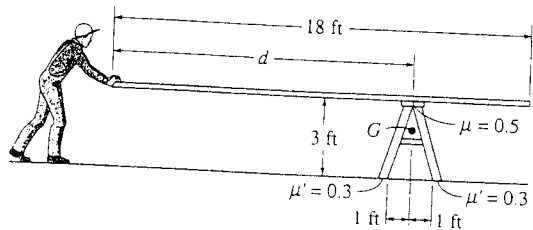

Board :

$$\zeta + \Sigma M_P = 0; \quad -54(9) + N(14) = 0$$

$$N = 34.714 \text{ lb}$$

To cause slipping of board on saw horse :

$$P_x = F_{max} = 0.5 N = 17.36 \text{ lb}$$

Saw horse :

To cause slipping at ground :

$$P_x = F = F_{max} = 0.3(34.714 + 15) = 14.91 \text{ lb}$$

To cause tipping :

$$\zeta + \Sigma M_B = 0; \quad (34.714 + 15)(1) - P_x(3) = 0$$

$$P_x = 16.57 \text{ lb}$$

Thus, $P_x = 14.9 \text{ lb}$ **Ans**

The saw horse will start to slip.

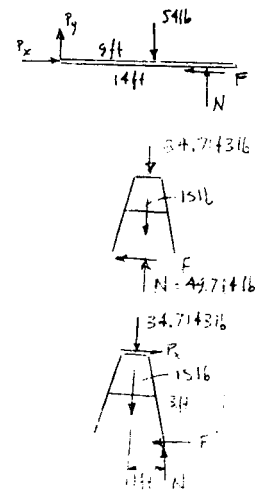

8-59. The 45-kg disk rests on the surface for which the coefficient of static friction is $\mu_A = 0.2$. Determine the largest couple moment M that can be applied to the bar without causing motion.

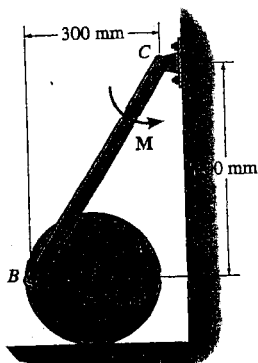

$$\zeta + \Sigma M_O = 0; \quad F_A = B_y = 0.2 N_A$$

$$\rightarrow \Sigma F_x = 0; \quad B_x - 0.2 N_A = 0$$

$$+ \uparrow \Sigma F_y = 0; \quad N_A - B_y - 45(9.81) = 0$$

$$N_A = 551.8 \text{ N}$$

$$B_x = 110.4 \text{ N}$$

$$B_y = 110.4 \text{ N}$$

$$\zeta + \Sigma M_C = 0; \quad -110.4(0.3) - 110.4(0.4) + M = 0$$

$$M = 77.3 \text{ N}\cdot\text{m} \quad \text{Ans}$$

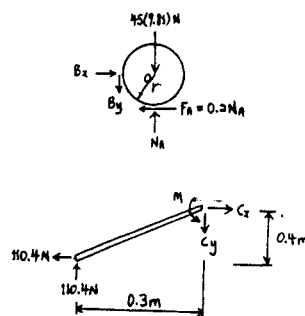

*8-60. The 45-kg disk rests on the surface for which the coefficient of static friction is $\mu_A = 0.15$. If $M = 50 \text{ N} \cdot \text{m}$, determine the friction force at A .

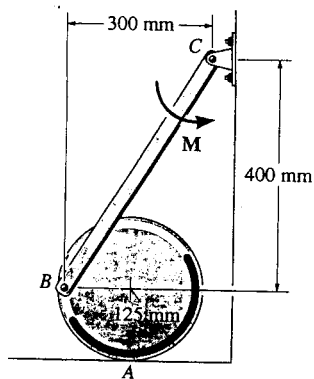

Bar :

$$(+\Sigma M_C = 0; \quad -B_y(0.3) - B_x(0.4) + 50 = 0$$

$$+\rightarrow \Sigma F_x = 0; \quad B_x = C_x$$

$$+\uparrow \Sigma F_y = 0; \quad B_y = C_y$$

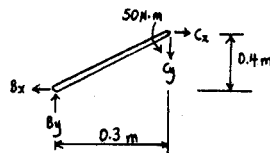

Disk :

$$+\rightarrow \Sigma F_x = 0; \quad B_x = F_A$$

$$+\uparrow \Sigma F_y = 0; \quad N_A - B_y - 45(9.81) = 0$$

$$(+\Sigma M_O = 0; \quad B_y(0.125) - F_A(0.125) = 0$$

$$N_A = 512.9 \text{ N}$$

$$F_A = 71.4 \text{ N} \quad \text{Ans}$$

$$(F_A)_{max} = 0.15(512.9) = 76.93 \text{ N} > 71.43 \text{ N}$$

No motion of disk.

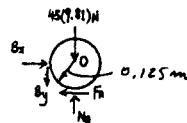

8-61. The end C of the two-bar linkage rests on the top center of the 50-kg cylinder. If the coefficients of static friction at C and E are $\mu_C = 0.6$ and $\mu_E = 0.3$, determine the largest vertical force P which can be applied at B without causing motion. Neglect the mass of the bars.

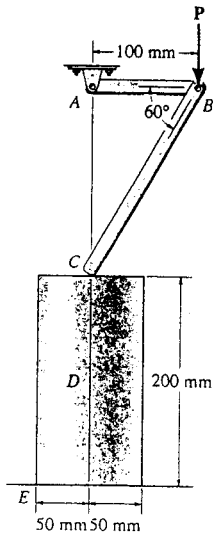

Joint B :

$$+\uparrow \Sigma F_y = 0; \quad F_{CB} \sin 60^\circ - P = 0$$

$$F_{CB} = 1.1547P$$

$$\text{Since } (F_C)_{max} = 0.6P > 1.1547P \cos 60^\circ = 0.5774P$$

Bar will not slip at C .

$$+\uparrow \Sigma F_y = 0; \quad N_E - 1.1547P \cos 30^\circ - 490.5 = 0$$

$$N_E = 490.5 + P$$

$$\rightarrow \Sigma F_x = 0; \quad F_E - 1.1547P \sin 30^\circ = 0$$

$$F_E = 0.5774P$$

$$(+\Sigma M_O = 0; \quad -490.5(x) - P(x) + 0.5774P(0.2) = 0$$

Assume tipping,

$$x = 0.05 \text{ m}$$

$$P = 375 \text{ N}$$

$$F_E = 216 \text{ N}$$

$$N_E = 865 \text{ N}$$

$$(F_E)_{max} = 0.3(865) = 259 \text{ N} > 216.5 \text{ N} \quad (\text{O.K.})$$

At C ,

$$(0.6)(375) = 225 > 0.577(375) = 216.4 \quad (\text{O.K.})$$

Cylinder tips,

$$P = 375 \text{ N} \quad \text{Ans}$$

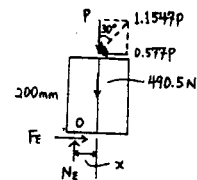
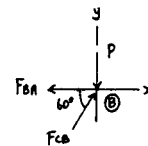

8-62. Determine the minimum applied force P required to move wedge A to the right. The spring is compressed a distance of 175 mm. Neglect the weight of A and B . The coefficient of static friction for all contacting surfaces is $\mu_s = 0.35$. Neglect friction at the rollers.

Equations of Equilibrium and Friction : Using the spring formula, $F_{sp} = kx = 15(0.175) = 2.625$ kN. If the wedge is on the verge of moving to the right, then slipping will have to occur at both contact surfaces. Thus, $F_A = \mu_s N_A = 0.35N_A$ and $F_B = \mu_s N_B = 0.35N_B$. From FBD (a),

$$+\uparrow \Sigma F_y = 0; \quad N_B - 2.625 = 0 \quad N_B = 2.625 \text{ kN}$$

From FBD (b),

$$+\uparrow \Sigma F_y = 0; \quad N_A \cos 10^\circ - 0.35N_A \sin 10^\circ - 2.625 = 0$$

$$N_A = 2.841 \text{ kN}$$

$$\rightarrow \Sigma F_x = 0; \quad P - 0.35(2.625) - 0.35(2.841) \cos 10^\circ - 2.841 \sin 10^\circ = 0$$

$$P = 2.39 \text{ kN} \quad \text{Ans}$$

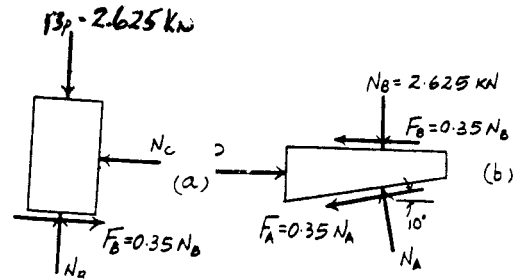
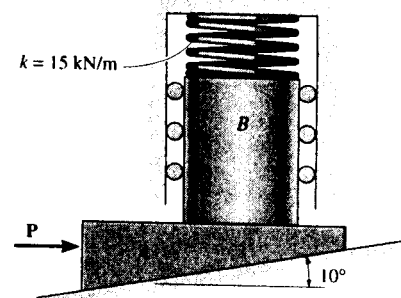

8-63. Determine the largest weight of the wedge that can be placed between the 8-lb cylinder and the wall without upsetting equilibrium. The coefficient of static friction at A and C is $\mu_s = 0.5$ and at B , $\mu_s = 0.6$.

Equations of Equilibrium : From FBD (a),

$$\rightarrow \Sigma F_x = 0; \quad N_B \cos 30^\circ - F_B \cos 60^\circ - N_C = 0 \quad [1]$$

$$+\uparrow \Sigma F_y = 0; \quad N_B \sin 30^\circ + F_B \sin 60^\circ + F_C - W = 0 \quad [2]$$

From FBD (b),

$$+\uparrow \Sigma F_y = 0; \quad N_A - N_B \sin 30^\circ - F_B \sin 60^\circ - 8 = 0 \quad [3]$$

$$\rightarrow \Sigma F_x = 0; \quad F_A + F_B \cos 60^\circ - N_B \cos 30^\circ = 0 \quad [4]$$

$$(+\Sigma M_O = 0; \quad F_A(0.5) - F_B(0.5) = 0 \quad [5]$$

Friction : Assume slipping occurs at points C and A , then $F_C = \mu_s N_C = 0.5N_C$ and $F_A = \mu_s N_A = 0.5N_A$. Substituting these values into Eqs. [1], [2], [3], [4], and [5] and solving, we have

$$W = 66.64 \text{ lb} = 66.6 \text{ lb} \quad \text{Ans}$$

$$N_B = 51.71 \text{ lb} \quad N_A = 59.71 \text{ lb} \quad F_B = N_C = 29.86 \text{ lb}$$

Since $(F_B)_{\max} = \mu_s N_B = 0.6(51.71) = 31.03 \text{ lb} > F_B$, slipping does not occur at point B . Therefore, the above assumption is correct.

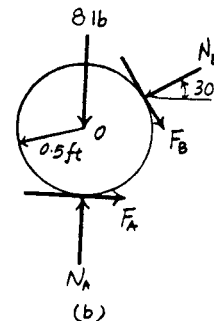
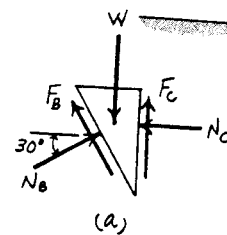
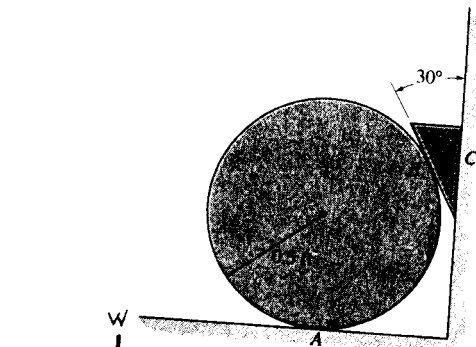

***8-64.** The wedge has a negligible weight and a coefficient of static friction $\mu_s = 0.35$ with all contacting surfaces. Determine the angle θ so that it is "self-locking." This requires no slipping for any magnitude of the force P applied to the joint.

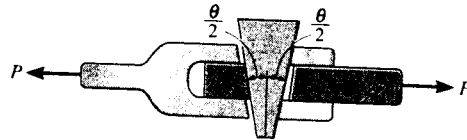

Friction : When the wedge is on the verge of slipping, then $F = \mu N = 0.35N$.
From the force diagram (P is the 'locking' force.),

$$\tan \frac{\theta}{2} = \frac{0.35N}{N} = 0.35$$

$$\theta = 38.6^\circ$$

Ans

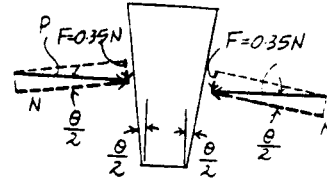

8-65. If the spring is compressed 60 mm and the coefficient of static friction between the tapered stub S and the slider A is $\mu_{SA} = 0.5$, determine the horizontal force P needed to move the slider forward. The stub is free to move without friction within the fixed collar C . The coefficient of static friction between A and surface B is $\mu_{AB} = 0.4$. Neglect the weights of the slider and stub.

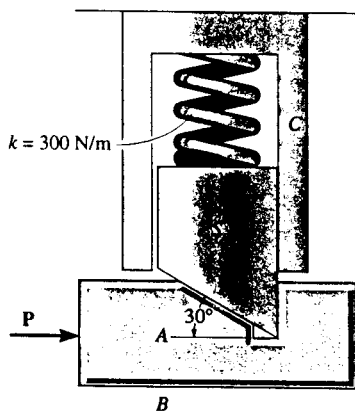

Stub :

$$+\uparrow \Sigma F_y = 0; \quad N_A \cos 30^\circ - 0.5N_A \sin 30^\circ - 300(0.06) = 0$$

$$N_A = 29.22 \text{ N}$$

Slider :

$$+\uparrow \Sigma F_y = 0; \quad N_B - 29.22 \cos 30^\circ + 0.5(29.22) \sin 30^\circ = 0$$

$$N_B = 18 \text{ N}$$

$$\rightarrow \Sigma F_x = 0;$$

$$P - 0.4(18) - 29.22 \sin 30^\circ - 0.5(29.22) \cos 30^\circ = 0$$

$$P = 34.5 \text{ N} \quad \text{Ans}$$

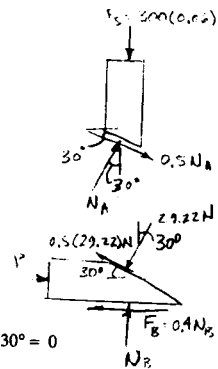

8-66. The coefficient of static friction between wedges *B* and *C* is $\mu_s = 0.6$ and between the surfaces of contact *B* and *A* and *C* and *D*, $\mu_s' = 0.4$. If the spring is compressed 200 mm when in the position shown, determine the smallest force *P* needed to move wedge *C* to the left. Neglect the weight of the wedges.

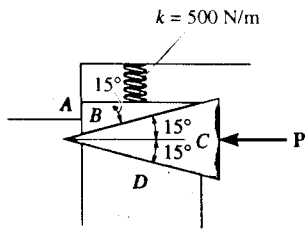

Wedge *B* :

$$\rightarrow \Sigma F_x = 0; \quad N_{AB} - 0.6N_{BC} \cos 15^\circ - N_{BC} \sin 15^\circ = 0$$

$$+\uparrow \Sigma F_y = 0; \quad N_{BC} \cos 15^\circ - 0.6N_{BC} \sin 15^\circ - 0.4N_{AB} - 100 = 0$$

$$N_{BC} = 210.4 \text{ N}$$

$$N_{AB} = 176.4 \text{ N}$$

Wedge *C* :

$$+\uparrow \Sigma F_y = 0; \quad N_{CD} \cos 15^\circ - 0.4N_{CD} \sin 15^\circ + 0.6(210.4) \sin 15^\circ - 210.4 \cos 15^\circ = 0$$

$$N_{CD} = 197.8 \text{ N}$$

$$\rightarrow \Sigma F_x = 0; \quad 197.8 \sin 15^\circ + 0.4(197.8) \cos 15^\circ + 210.4 \sin 15^\circ + 0.6(210.4) \cos 15^\circ - P = 0$$

$$P = 304 \text{ N} \quad \text{Ans}$$

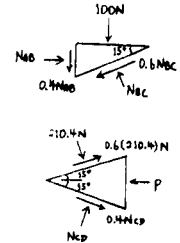

8-67. The coefficient of static friction between the wedges *B* and *C* is $\mu_s = 0.6$ and between the surfaces of contact *B* and *A* and *C* and *D*, $\mu_s' = 0.4$. If $P = 50 \text{ N}$, determine the largest allowable compression of the spring without causing wedge *C* to move to the left. Neglect the weight of the wedges.

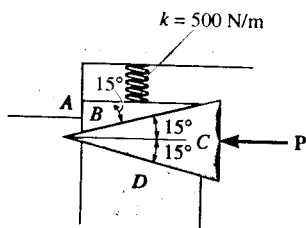

Wedge *C* :

$$\rightarrow \Sigma F_x = 0; \quad (N_{CD} + N_{BC}) \sin 15^\circ + (0.4N_{CD} + 0.6N_{BC}) \cos 15^\circ - 50 = 0$$

$$+\uparrow \Sigma F_y = 0; \quad (N_{CD} - N_{BC}) \cos 15^\circ + (-0.4N_{CD} + 0.6N_{BC}) \sin 15^\circ = 0$$

$$N_{BC} = 34.61 \text{ N}$$

$$N_{CD} = 32.53 \text{ N}$$

Wedge *B* :

$$\rightarrow \Sigma F_x = 0; \quad N_{AB} - 0.6(34.61) \cos 15^\circ - 34.61 \sin 15^\circ = 0$$

$$N_{AB} = 29.01 \text{ N}$$

$$+\uparrow \Sigma F_y = 0; \quad 34.61 \cos 15^\circ - 0.6(34.61) \sin 15^\circ - 0.4(29.01) - 500x = 0$$

$$x = 0.03290 \text{ m} = 32.9 \text{ mm} \quad \text{Ans}$$

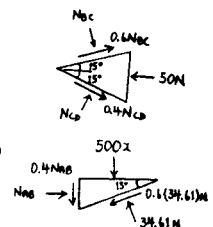

***8-68.** The wedge blocks are used to hold the specimen in a tension testing machine. Determine the design angle θ of the wedges so that the specimen will not slip regardless of the applied load. The coefficients of static friction are $\mu_A = 0.1$ at A and $\mu_B = 0.6$ at B . Neglect the weight of the blocks.

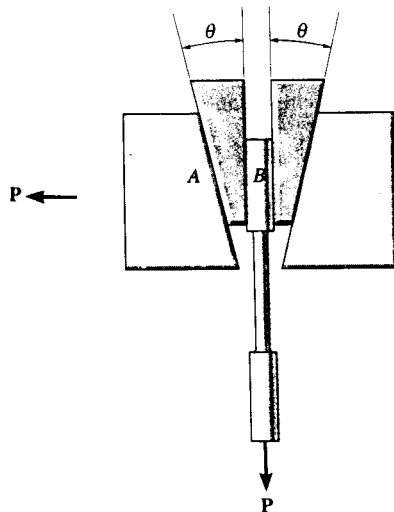

Specimen:

$$+\uparrow \Sigma F_y = 0;$$

$$F_B = \frac{P}{2}$$

Wedge:

$$\rightarrow \Sigma F_x = 0;$$

$$N_A \cos \theta - 0.1N_A \sin \theta - \frac{P}{2} = 0$$

$$+\uparrow \Sigma F_y = 0;$$

$$0.1N_A \cos \theta + N_A \sin \theta - \frac{P}{2} = 0$$

$$P = 2N_A(0.1 \cos \theta + \sin \theta)$$

$$0.6N_A(\cos \theta - 0.1 \sin \theta) - N_A(0.1 \cos \theta + \sin \theta) = 0$$

$$0.5 \cos \theta - 1.06 \sin \theta = 0$$

$$\theta = \tan^{-1}\left(\frac{0.5}{1.06}\right) = 25.3^\circ \quad \text{Ans}$$

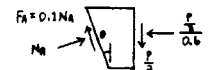
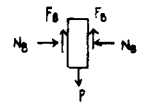

8-69. The beam is adjusted to the horizontal position by means of a wedge located at its right support. If the coefficient of static friction is $\mu_s = 0.25$, determine the horizontal force P required to push the wedge forward. Neglect the weight and size of the wedge and the thickness of the beam.

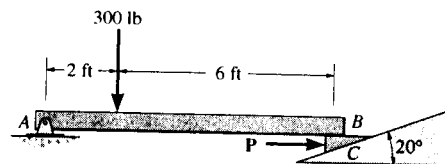

Equations of Equilibrium and Friction: If the wedge is on the verge of moving to the right, then slipping will have to occur at both contact surfaces. Thus, $F_B = \mu_s N_B = 0.25N_B$ and $F_C = \mu_s N_C = 0.25N_C$. From FBD (a),

$$\left(+\Sigma M_A = 0; \quad N_B(8) - 300(2) = 0 \quad N_B = 75.0 \text{ lb} \right.$$

From FBD (b),

$$+\uparrow \Sigma F_y = 0; \quad N_C \sin 70^\circ - 0.25N_C \sin 20^\circ - 75.0 = 0$$

$$N_C = 87.80 \text{ lb}$$

$$\rightarrow \Sigma F_x = 0; \quad P - 0.25(75.0) - 0.25(87.80) \cos 20^\circ - 87.80 \cos 70^\circ = 0$$

$$P = 69.4 \text{ lb} \quad \text{Ans}$$

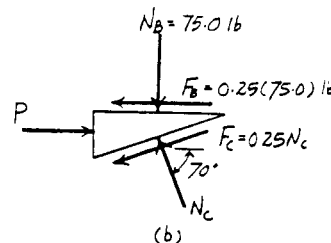
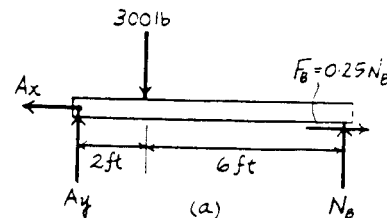

8-70. If the beam AD is loaded as shown, determine the horizontal force P which must be applied to the wedge in order to remove it from under the beam. The coefficients of static friction at the wedge's top and bottom surfaces are $\mu_{CA} = 0.25$ and $\mu_{CB} = 0.35$, respectively. If $P = 0$, is the wedge self-locking? Neglect the weight and size of the wedge and the thickness of the beam.

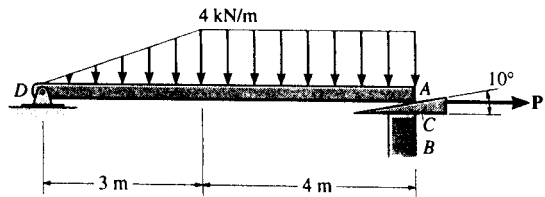

Equations of Equilibrium and Friction: If the wedge is on the verge of moving to the right, then slipping will have to occur at both contact surfaces. Thus, $F_A = \mu_{CA} N_A = 0.25N_A$ and $F_B = \mu_{CB} N_B = 0.35N_B$. From FBD (a),

$$\begin{aligned} +\Sigma M_D = 0; \quad N_A \cos 10^\circ (7) + 0.25N_A \sin 10^\circ (7) - 6.00(2) - 16.0(5) &= 0 \\ N_A &= 12.78 \text{ kN} \end{aligned}$$

From FBD (b),

$$\begin{aligned} +\uparrow \Sigma F_y = 0; \quad N_B - 12.78 \sin 80^\circ - 0.25(12.78) \sin 10^\circ &= 0 \\ N_B &= 13.14 \text{ kN} \\ \rightarrow \Sigma F_x = 0; \quad P + 12.78 \cos 80^\circ - 0.25(12.78) \cos 10^\circ - 0.35(13.14) &= 0 \\ P &= 5.53 \text{ kN} \end{aligned}$$

Ans

Since a force $P(>0)$ is required to pull out the wedge, the wedge will be self-locking when $P=0$.

Ans

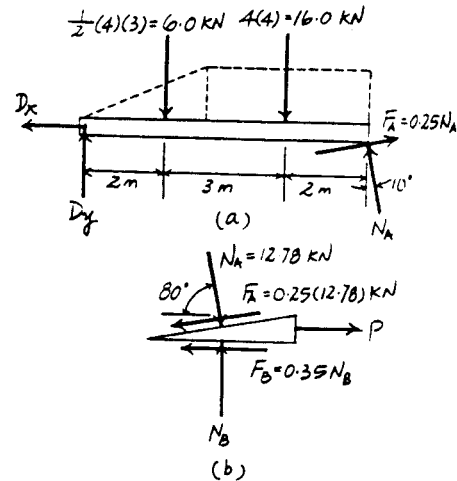

8-71. The column is used to support the upper floor. If a force $F = 80 \text{ N}$ is applied perpendicular to the handle to tighten the screw, determine the compressive force in the column. The square-threaded screw on the jack has a coefficient of static friction of $\mu_s = 0.4$, mean diameter of 25 mm, and a lead of 3 mm.

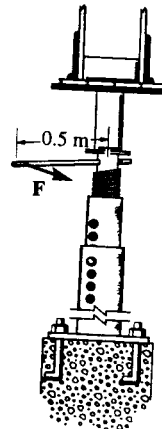

$$M = W(r) \tan(\phi_s + \theta_p)$$

$$\phi_s = \tan^{-1}(0.4) = 21.80^\circ$$

$$\theta_p = \tan^{-1}\left[\frac{3}{2\pi(12.5)}\right] = 2.188^\circ$$

$$80(0.5) = W(0.0125) \tan(21.80^\circ + 2.188^\circ)$$

$$W = 7.19 \text{ kN} \quad \text{Ans}$$

*8-72. If the force F is removed from the handle of the jack in Prob. 8-71, determine if the screw is self-locking.

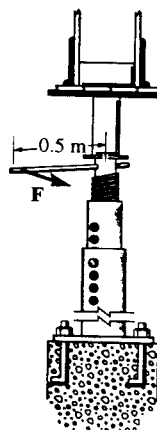

$$\phi_s = \tan^{-1}(0.4) = 21.80^\circ$$

$$\theta_p = \tan^{-1}\left[\frac{3}{2\pi(12.5)}\right] = 2.188^\circ$$

Since $\phi_s > \theta_p$, Screw is self locking. Ans

8-73. The square-threaded screw has a mean diameter of 20 mm and a lead of 4 mm. If the weight of the plate A is 5 lb, determine the smallest coefficient of static friction between the screw and the plate so that the plate does not travel down the screw when the plate is suspended as shown.

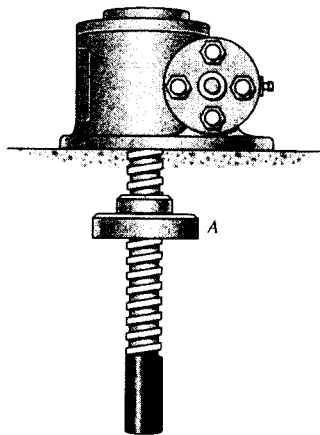

Frictional Forces on Screw : This requires a "self-locking" screw where

$$\phi_s \geq \theta. \text{ Here, } \theta = \tan^{-1} \left(\frac{l}{2\pi r} \right) = \tan^{-1} \left[\frac{4}{2\pi(10)} \right] = 3.643^\circ.$$

$$\begin{aligned} \phi_s &= \tan^{-1} \mu_s \\ \mu_s &= \tan \phi_s \quad \text{where } \phi_s = \theta = 3.643^\circ \\ &= 0.0637 \quad \text{Ans} \end{aligned}$$

8-74. The square threaded screw of the clamp has a mean diameter of 14 mm and a lead of 6 mm. If $\mu_s = 0.2$ for the threads, and the torque applied to the handle is $1.5 \text{ N} \cdot \text{m}$, determine the compressive force F on the block.

Frictional Forces on Screw : Here, $\theta = \tan^{-1} \left(\frac{l}{2\pi r} \right) = \tan^{-1} \left[\frac{6}{2\pi(7)} \right] = 7.768^\circ.$

$W = F$ and $\phi_s = \tan^{-1} \mu_s = \tan^{-1} (0.2) = 11.310^\circ.$ Applying Eq. 8-3, we have

$$\begin{aligned} M &= Wr \tan(\theta + \phi) \\ 1.5 &= F(0.007) \tan(7.768^\circ + 11.310^\circ) \end{aligned}$$

$$F = 620 \text{ N}$$

Ans

Note : Since $\phi_s > \theta$, the screw is self-locking. It will not unscrew even if the moment is removed.

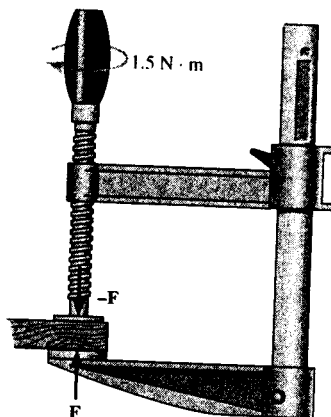

8-75. The device is used to pull the battery cable terminal C from the post of a battery. If the required pulling force is 85 lb, determine the torque M that must be applied to the handle on the screw to tighten it. The screw has square threads, a mean diameter of 0.2 in., a lead of 0.08 in., and the coefficient of static friction is $\mu_s = 0.5$.

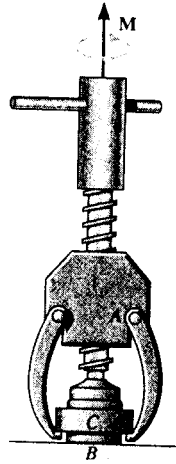

Frictional Forces on Screw : Here, $\theta = \tan^{-1}\left(\frac{l}{2\pi r}\right) = \tan^{-1}\left[\frac{0.08}{2\pi(0.1)}\right] = 7.256^\circ$,
 $W = 85$ lb and $\phi_s = \tan^{-1}\mu_s = \tan^{-1}(0.5) = 26.565^\circ$. Applying Eq. 8-3, we have

$$\begin{aligned} M &= Wr \tan(\theta + \phi) \\ &= 85(0.1) \tan(7.256^\circ + 26.565^\circ) \\ &= 5.69 \text{ lb} \cdot \text{in} \end{aligned}$$

Ans

Note : Since $\phi_s > \theta$, the screw is self-locking. It will not unscrew even if the moment is removed.

8-76. The automobile jack is subjected to a vertical load of $F = 8 \text{ kN}$. If a square-threaded screw, having a lead of 5 mm and a mean diameter of 10 mm , is used in the jack, determine the force that must be applied perpendicular to the handle to (a) raise the load, and (b) lower the load; $\mu_s = 0.2$. The supporting plate exerts only vertical forces at A and B , and each cross link has a total length of 200 mm .

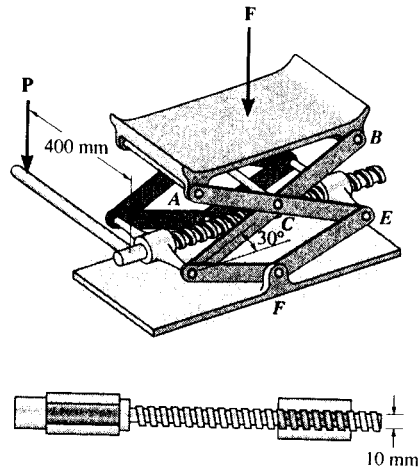

Equations of Equilibrium : From FBD (a),

$$\left(+ \Sigma M_E = 0; \quad 8(x) - D_y(2x) = 0 \quad D_y = 4.00 \text{ kN} \right.$$

From FBD (b),

$$\left(+ \Sigma M_A = 0; \quad F_B(2x) - 8(x) = 0 \quad F_B = 4.00 \text{ kN} \right.$$

From FBD (c),

$$\left(+ \Sigma M_C = 0; \quad D_x(0.1 \sin 30^\circ) - 4.00(0.2 \cos 30^\circ) = 0 \right. \\ \left. D_x = 13.86 \text{ kN} \right.$$

Member DF is a two force member. Analysing the forces that act on pin D [FBD (d)], we have

$$\begin{aligned} + \uparrow \Sigma F_y = 0; \quad F_{DF} \sin 30^\circ - 4.00 = 0 \quad F_{DF} = 8.00 \text{ kN} \\ \rightarrow \Sigma F_x = 0; \quad P' - 13.86 - 8.00 \cos 30^\circ = 0 \quad P' = 20.78 \text{ kN} \end{aligned}$$

Frictional Forces on Screw : Here, $\theta = \tan^{-1} \left(\frac{l}{2\pi r} \right) = \tan^{-1} \left[\frac{5}{2\pi(5)} \right] = 9.043^\circ$,

$W = P' = 20.78 \text{ kN}$, $M = 0.4P$ and $\phi_s = \tan^{-1} \mu_s = \tan^{-1}(0.2) = 11.310^\circ$. Applying Eq. 8-3 if the jack is raising the load, we have

$$\begin{aligned} M &= Wr \tan(\theta + \phi) \\ 0.4P &= 20.78(0.005) \tan(9.043^\circ + 11.310^\circ) \\ P &= 0.09638 \text{ kN} = 96.4 \text{ N} \end{aligned} \quad \text{Ans}$$

Applying Eq. 8-5 if the jack is lowering the load, we have

$$\begin{aligned} M'' &= Wr \tan(\phi - \theta) \\ 0.4P &= 20.78(0.005) \tan(11.310^\circ - 9.043^\circ) \\ P &= 0.01028 \text{ kN} = 10.3 \text{ N} \end{aligned} \quad \text{Ans}$$

Note : Since $\phi_s > \theta$, the screw is self-locking. It will not unscrew even if force P is removed.

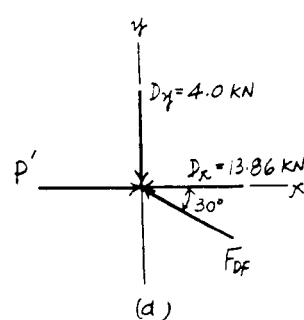
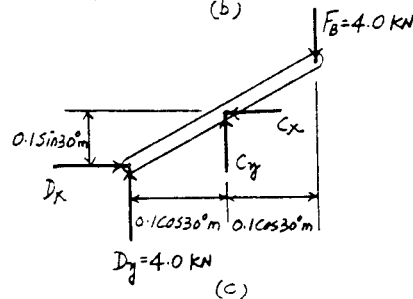
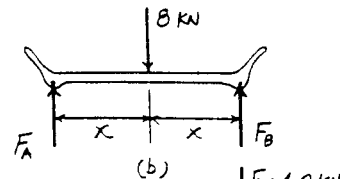
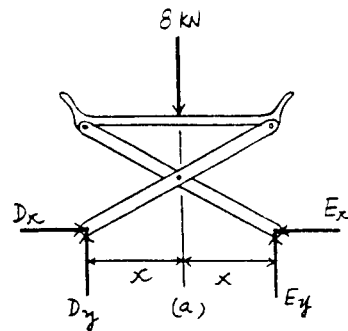

8-77. Determine the clamping force on the board *A* if the screw of the "C" clamp is tightened with a twist of $M = 8 \text{ N}\cdot\text{m}$. The single square-threaded screw has a mean radius of 10 mm, a lead of 3 mm, and the coefficient of static friction is $\mu_s = 0.35$.

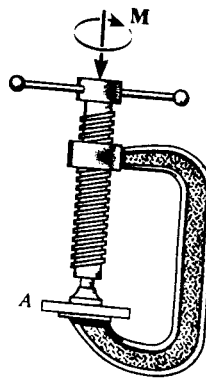

$$\phi_s = \tan^{-1}(0.35) = 19.29^\circ$$

$$\theta_p = \tan^{-1}\left[\frac{3}{2\pi(10)}\right] = 2.734^\circ$$

$$M = W(r) \tan(\phi_s + \theta_p)$$

$$8 = F(0.01) \tan(19.29^\circ + 2.734^\circ)$$

$$P = 1978 \text{ N} = 1.98 \text{ kN} \quad \text{Ans}$$

8-78. If the required clamping force at the board *A* is to be 50 N, determine the torque M that must be applied to the handle of the "C" clamp to tighten it down. The single square-threaded screw has a mean radius of 10 mm, a lead of 3 mm, and the coefficient of static friction is $\mu_s = 0.35$.

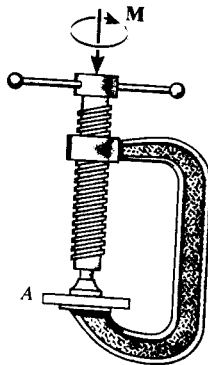

$$\phi_s = \tan^{-1}(0.35) = 19.29^\circ$$

$$\theta_p = \tan^{-1}\left(\frac{P}{2\pi r}\right) = \tan^{-1}\left[\frac{3}{2\pi(10)}\right] = 2.734^\circ$$

$$M = W(r) \tan(\phi_s + \theta_p)$$

$$= 50(0.01) \tan(19.29^\circ + 2.734^\circ) = 0.202 \text{ N}\cdot\text{m} \quad \text{Ans}$$

8-79. The shaft has a square-threaded screw with a lead of 8 mm and a mean radius of 15 mm. If it is in contact with a plate gear having a mean radius of 30 mm, determine the resisting torque M on the plate gear which can be overcome if a torque of $7 \text{ N}\cdot\text{m}$ is applied to the shaft. The coefficient of static friction at the screw is $\mu_B = 0.2$. Neglect friction of the bearings located at *A* and *B*.

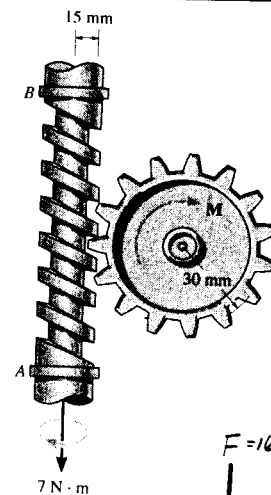

Frictional Forces on Screw : Here, $\theta = \tan^{-1}\left(\frac{l}{2\pi r}\right) = \tan^{-1}\left[\frac{8}{2\pi(15)}\right] = 4.852^\circ$.

$W = F$, $M = 7 \text{ N}\cdot\text{m}$ and $\phi_s = \tan^{-1}\mu_s = \tan^{-1}(0.2) = 11.310^\circ$. Applying Eq. 8-3, we have

$$M = W r \tan(\theta + \phi)$$

$$7 = F(0.015) \tan(4.852^\circ + 11.310^\circ)$$

$$F = 1610.29 \text{ N}$$

Note : Since $\phi_s > \theta$, the screw is self-locking. It will not unscrew even if force F is removed.

Equations of Equilibrium :

$$+\Sigma M_O = 0; \quad 1610.29(0.03) - M = 0$$

$$M = 48.3 \text{ N}\cdot\text{m} \quad \text{Ans}$$

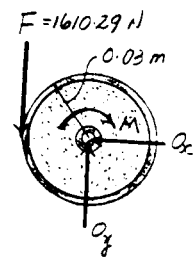

*8-80. The braking mechanism consists of two pinned arms and a square-threaded screw with left and right-hand threads. Thus when turned, the screw draws the two arms together. If the lead of the screw is 4 mm, the mean diameter 12 mm, and the coefficient of static friction is $\mu_s = 0.35$, determine the tension in the screw when a torque of $5 \text{ N} \cdot \text{m}$ is applied to tighten the screw. If the coefficient of static friction between the brake pads A and B and the circular shaft is $\mu'_s = 0.5$, determine the maximum torque M the brake can resist.

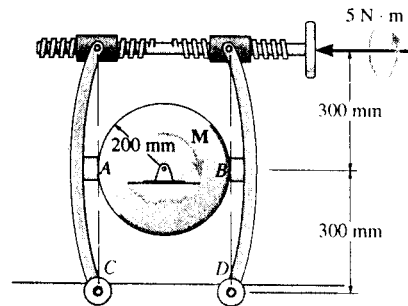

Frictional Forces on Screw : Here, $\theta = \tan^{-1} \left(\frac{l}{2\pi r} \right) = \tan^{-1} \left[\frac{4}{2\pi(6)} \right] = 6.057^\circ$.

$M = 5 \text{ N} \cdot \text{m}$ and $\phi_s = \tan^{-1} \mu_s = \tan^{-1} (0.35) = 19.290^\circ$. Since friction at two screws must be overcome, then, $W = 2P$. Applying Eq. 8-3, we have

$$\begin{aligned} M &= W r \tan(\theta + \phi) \\ 5 &= 2P(0.006) \tan(6.057^\circ + 19.290^\circ) \\ P &= 879.61 \text{ N} = 880 \text{ N} \end{aligned}$$

Ans

Note : Since $\phi_s > \theta$, the screw is self-locking. It will not unscrew even if moment M is removed.

Equations of Equilibrium and Friction : Since the shaft is on the verge to rotate about point O , then, $F_A = \mu'_s N_A = 0.5N_A$ and $F_B = \mu'_s N_B = 0.5N_B$. From FBD (a),

$$(+\Sigma M_D = 0; \quad 879.61(0.6) - N_B(0.3) = 0 \quad N_B = 1759.22 \text{ N}$$

From FBD (b),

$$(+\Sigma M_O = 0; \quad 2[0.5(1759.22)](0.2) - M = 0 \quad M = 352 \text{ N} \cdot \text{m} \quad \text{Ans}$$

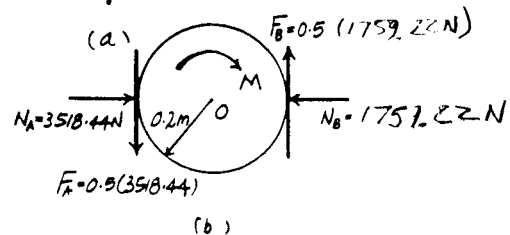
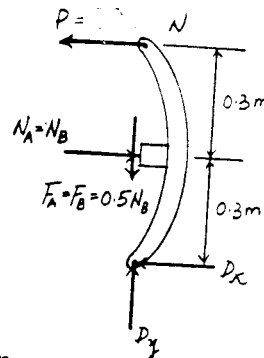

8-81. The fixture clamp consist of a square-threaded screw having a coefficient of static friction of $\mu_s = 0.3$, mean diameter of 3 mm, and a lead of 1 mm. The five points indicated are pin connections. Determine the clamping force at the smooth blocks D and E when a torque of $M = 0.08 \text{ N} \cdot \text{m}$ is applied to the handle of the screw.

Frictional Forces on Screw : Here, $\theta = \tan^{-1} \left(\frac{l}{2\pi r} \right) = \tan^{-1} \left[\frac{1}{2\pi(1.5)} \right] = 6.057^\circ$, $W = P$, $M = 0.08 \text{ N} \cdot \text{m}$ and $\phi_s = \tan^{-1} \mu_s = \tan^{-1} (0.3) = 16.699^\circ$. Applying Eq. 8-3, we have

$$\begin{aligned} M &= W r \tan(\theta + \phi) \\ 0.08 &= P(0.0015) \tan(6.057^\circ + 16.699^\circ) \\ P &= 127.15 \text{ N} \end{aligned}$$

Note : Since $\phi_s > \theta$, the screw is self-locking. It will not unscrew even if moment M is removed.

Equation of Equilibrium :

$$(+\Sigma M_C = 0; \quad 127.15 \cos 45^\circ (40) - F_E \cos 45^\circ (40) - F_E \sin 45^\circ (30) = 0$$

$$F_E = 72.65 \text{ N} = 72.7 \text{ N} \quad \text{Ans}$$

The equilibrium of clamped block requires that

$$F_D = F_E = 72.7 \text{ N} \quad \text{Ans}$$

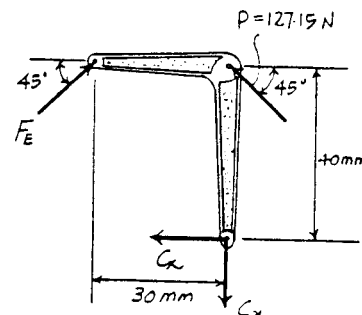
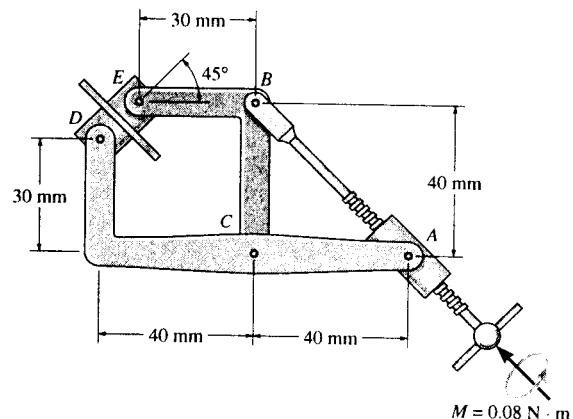

8-82. The clamp provides pressure from several directions on the edges of the board. If the square-threaded screw has a lead of 3 mm, radius of 10 mm, and the coefficient of static friction is $\mu_s = 0.4$, determine the horizontal force developed on the board at A and the vertical forces developed at B and C if a torque of $M = 1.5 \text{ N} \cdot \text{m}$ is applied to the handle to tighten it further. The blocks at B and C are pin-connected to the board.

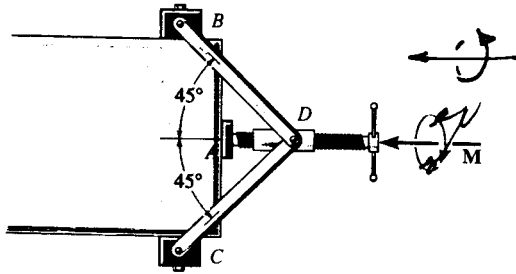

$$\phi_s = \tan^{-1}(0.4) = 21.801^\circ$$

$$\theta_p = \tan^{-1}\left[\frac{3}{2\pi(10)}\right] = 2.734^\circ$$

$$M = W(r)\tan(\phi_s + \theta_p)$$

$$1.5 = A_x(0.01)\tan(21.801^\circ + 2.734^\circ)$$

$$A_x = 328.6 \text{ N} \quad \text{Ans}$$

$$\rightarrow \Sigma F_x = 0; \quad 328.6 - 2T \cos 45^\circ = 0$$

$$T = 232.36 \text{ N}$$

$$B_y = C_y = 232.36 \sin 45^\circ = 164 \text{ N} \quad \text{Ans}$$

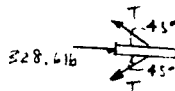

8-83. A turnbuckle, similar to that shown in Fig. 8-18, is used to tension member AB of the truss. The coefficient of the static friction between the square threaded screws and the turnbuckle is $\mu_s = 0.5$. The screws have a mean radius of 6 mm and a lead of 3 mm. If a torque of $M = 10 \text{ N} \cdot \text{m}$ is applied to the turnbuckle, to draw the screws closer together, determine the force in each member of the truss. No external forces act on the truss.

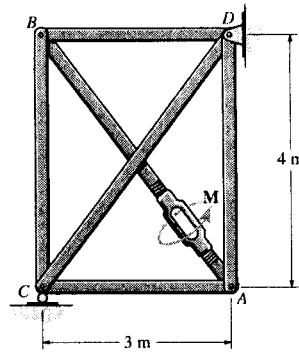

Frictional Forces on Screw: Here, $\theta = \tan^{-1} \left(\frac{l}{2\pi r} \right) = \tan^{-1} \left[\frac{3}{2\pi(6)} \right] = 4.550^\circ$, $M = 5 \text{ N} \cdot \text{m}$ and $\phi_s = \tan^{-1} \mu_s = \tan^{-1}(0.5) = 26.565^\circ$. Since friction at two screws must be overcome, then, $W = 2F_{AB}$. Applying Eq. 8-3, we have

$$M = W r \tan(\theta + \phi)$$

$$10 = 2F_{AB}(0.006) \tan(4.550^\circ + 26.565^\circ)$$

$$F_{AB} = 1380.62 \text{ N (T)} = 1.38 \text{ kN(T)} \quad \text{Ans}$$

Note: Since $\phi_s > \theta$, the screw is self-locking. It will not unscrew even if moment M is removed.

Method of Joints:

Joint B

$$\rightarrow \Sigma F_x = 0; \quad 1380.62 \left(\frac{3}{5} \right) - F_{BD} = 0$$

$$F_{BD} = 828.37 \text{ N(C)} = 828 \text{ N (C)} \quad \text{Ans}$$

$$+ \uparrow \Sigma F_y = 0; \quad F_{BC} - 1380.62 \left(\frac{4}{5} \right) = 0$$

$$F_{BC} = 1104.50 \text{ N (C)} = 1.10 \text{ kN (C)} \quad \text{Ans}$$

Joint A

$$\rightarrow \Sigma F_x = 0; \quad F_{AC} - 1380.62 \left(\frac{3}{5} \right) = 0$$

$$F_{AC} = 828.37 \text{ N (C)} = 828 \text{ N (C)} \quad \text{Ans}$$

$$+ \uparrow \Sigma F_y = 0; \quad 1380.62 \left(\frac{4}{5} \right) - F_{AD} = 0$$

$$F_{AD} = 1104.50 \text{ N (C)} = 1.10 \text{ kN (C)} \quad \text{Ans}$$

Joint C

$$\rightarrow \Sigma F_x = 0; \quad F_{CD} \left(\frac{3}{5} \right) - 828.37 = 0$$

$$F_{CD} = 1380.62 \text{ N (T)} = 1.38 \text{ kN (T)} \quad \text{Ans}$$

$$+ \uparrow \Sigma F_y = 0; \quad C_y + 1380.62 \left(\frac{4}{5} \right) - 1104.50 = 0$$

$$C_y = 0 \text{ (No external applied load, check!)} \quad \text{Ans}$$

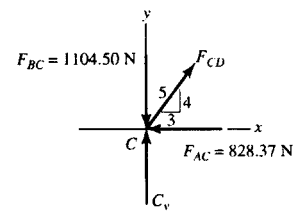
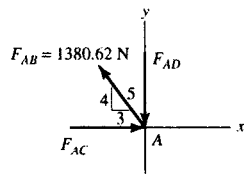
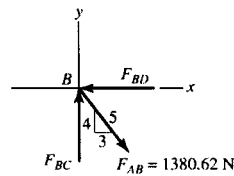

*8-84. A turnbuckle, similar to that shown in Fig. 8-18, is used to tension member AB of the truss. The coefficient of the static friction between the square-threaded screws and the turnbuckle is $\mu_s = 0.5$. The screws have a mean radius of 6 mm and a lead of 3 mm. Determine the torque M which must be applied to the turnbuckle to draw the screws closer together, so that the compressive force of 500 N is developed in member BC .

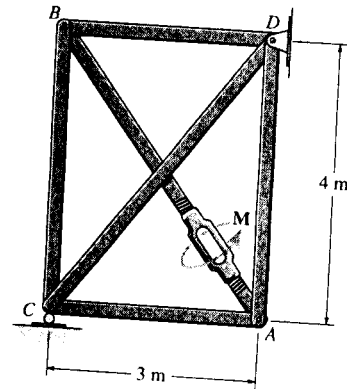

Method of Joints :

Joint B

$$+\uparrow \Sigma F_y = 0; \quad 500 - F_{AB} \left(\frac{4}{5}\right) = 0 \quad F_{AB} = 625 \text{ N (C)}$$

Frictional Forces on Screws : Here, $\theta = \tan^{-1} \left(\frac{l}{2\pi r} \right) = \tan^{-1} \left[\frac{3}{2\pi(6)} \right] = 4.550^\circ$, $M = 5 \text{ N} \cdot \text{m}$ and $\phi_s = \tan^{-1} \mu_s = \tan^{-1}(0.5) = 26.565^\circ$. Since friction at two screws must be overcome, then, $W = 2F_{AB} = 2(625) = 1250 \text{ N}$. Applying Eq. 8-3, we have

$$\begin{aligned} M &= W r \tan(\theta + \phi) \\ &= 1250(0.006) \tan(4.550^\circ + 26.565^\circ) \\ &= 4.53 \text{ N} \cdot \text{m} \end{aligned}$$

Ans

Note : Since $\phi_s > \theta$, the screw is self-locking. It will not unscrew even if moment M is removed.

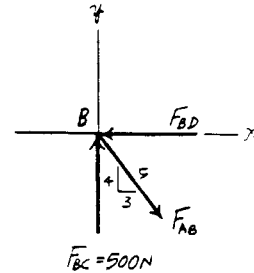

8-85. A "hawser" is wrapped around a fixed "capstan" to secure a ship for docking. If the tension in the rope, caused by the ship, is 1500 lb, determine the least number of complete turns the rope must be rapped around the capstan in order to prevent slipping of the rope. The greatest horizontal force that a longshoreman can exert on the rope is 50 lb. The coefficient of static friction is $\mu_s = 0.3$.

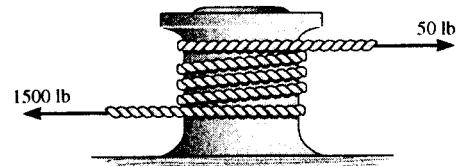

Frictional Force on Flat Belt : Here, $T_1 = 50 \text{ lb}$ and $T_2 = 1500 \text{ lb}$. Applying Eq. 8-6, we have

$$\begin{aligned} T_2 &= T_1 e^{\mu \beta} \\ 1500 &= 50 e^{0.3\beta} \end{aligned}$$

$$\beta = 11.337 \text{ rad}$$

The least number of turns of the rope required is $\frac{11.337}{2\pi} = 1.80$ turns. Thus

$$\text{Use } n = 2 \text{ turns} \quad \text{Ans}$$

8-86. The truck, which has a mass of 3.4 Mg, is to be lowered down the slope by a rope that is wrapped around a tree. If the wheels are free to roll and the man at A can resist a pull of 300 N, determine the minimum number of turns the rope should be wrapped around the tree to lower the truck at a constant speed. The coefficient of kinetic friction between the tree and rope is $\mu_k = 0.3$.

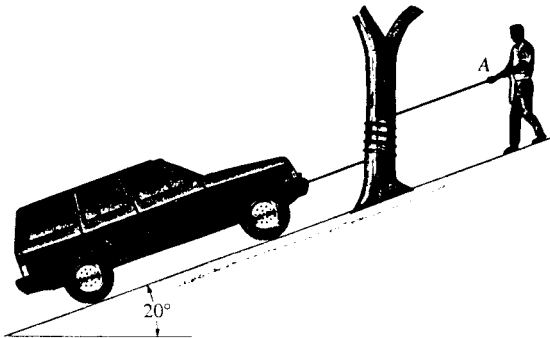

$$\sum F_x = 0;$$

$$T_2 - 33\,354 \sin 20^\circ = 0$$

$$T_2 = 11\,407.7$$

$$T_2 = T_1 e^{\mu\beta}$$

$$11\,407.7 = 300 e^{0.3\beta}$$

$$\beta = 12.1275 \text{ rad}$$

$$\text{Approx. 2 turns (695^\circ)}$$

Ans

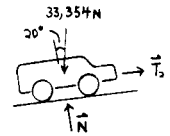

8-87. Determine the maximum and the minimum values of weight W which may be applied without causing the 50-lb block to slip. The coefficient of static friction between the block and the plane is $\mu_s = 0.2$, and between the rope and the drum $\mu' = 0.3$.

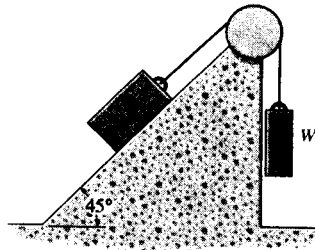

Equations of Equilibrium and Friction: Since the block is on the verge of sliding up or down the plane, then, $F = \mu_s N = 0.2N$. If the block is on the verge of sliding up the plane [FBD (a)],

$$\sum F_y = 0; \quad N - 50 \cos 45^\circ = 0 \quad N = 35.36 \text{ lb}$$

$$\sum F_x = 0; \quad T_1 - 0.2(35.36) - 50 \sin 45^\circ = 0 \quad T_1 = 42.43 \text{ lb}$$

If the block is on the verge of sliding down the plane [FBD (b)],

$$\sum F_y = 0; \quad N - 50 \cos 45^\circ = 0 \quad N = 35.36 \text{ lb}$$

$$\sum F_x = 0; \quad T_2 + 0.2(35.36) - 50 \sin 45^\circ = 0 \quad T_2 = 28.28 \text{ lb}$$

Frictional Force on Flat Belt: Here, $\beta = 45^\circ + 90^\circ = 135^\circ = \frac{3\pi}{4}$ rad.

If the block is on the verge of sliding up the plane, $T_1 = 42.43$ lb and $T_2 = W$.

$$T_2 = T_1 e^{\mu'\beta}$$

$$W = 42.43 e^{0.3(\frac{3\pi}{4})}$$

$$= 86.02 \text{ lb} = 86.0 \text{ lb}$$

Ans

If the block is on the verge of sliding down the plane, $T_1 = W$ and $T_2 = 28.28$ lb.

$$T_2 = T_1 e^{\mu'\beta}$$

$$28.28 = W e^{0.3(\frac{3\pi}{4})}$$

$$W = 13.95 \text{ lb} = 13.9 \text{ lb}$$

Ans

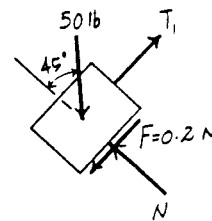

(a)

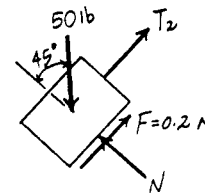

(b)

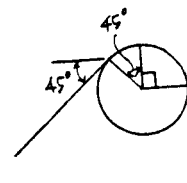

***8-88.** A cylinder having a mass of 250 kg is to be supported by the cord which wraps over the pipe. Determine the smallest vertical force F needed to support the load if the cord passes (a) once over the pipe, $\beta = 180^\circ$, and (b) two times over the pipe, $\beta = 540^\circ$. Take $\mu_s = 0.2$.

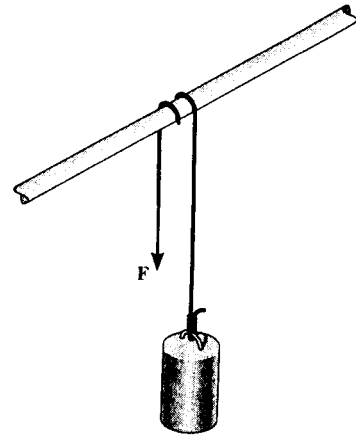

Frictional Force on Flat Belt : Here, $T_1 = F$ and $T_2 = 250(9.81) = 2452.5 \text{ N}$. Applying Eq. 8-6, we have

a) If $\beta = 180^\circ = \pi \text{ rad}$

$$T_2 = T_1 e^{\mu\beta}$$

$$2452.5 = F e^{0.2\pi}$$

$$F = 1308.38 \text{ N} = 1.31 \text{ kN} \quad \text{Ans}$$

b) If $\beta = 540^\circ = 3\pi \text{ rad}$

$$T_2 = T_1 e^{\mu\beta}$$

$$2452.5 = F e^{0.2(3\pi)}$$

$$F = 372.38 \text{ N} = 372 \text{ N} \quad \text{Ans}$$

8-89. A cylinder having a mass of 250 kg is to be supported by the cord which wraps over the pipe. Determine the largest vertical force F that can be applied to the cord without moving the cylinder. The cord passes (a) once over the pipe, $\beta = 180^\circ$, and (b) two times over the pipe, $\beta = 540^\circ$. Take $\mu_s = 0.2$.

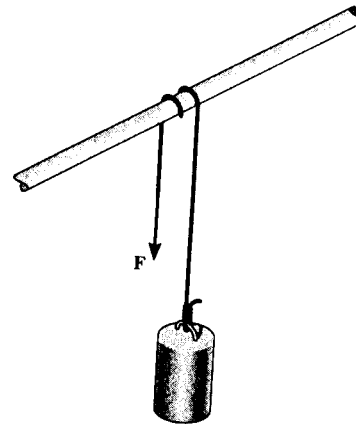

Frictional Force on Flat Belt : Here, $T_1 = 250(9.81) = 2452.5 \text{ N}$ and $T_2 = F$. Applying Eq. 8-6, we have

a) If $\beta = 180^\circ = \pi \text{ rad}$

$$T_2 = T_1 e^{\mu\beta}$$

$$F = 2452.5 e^{0.2\pi}$$

$$F = 4597.10 \text{ N} = 4.60 \text{ kN} \quad \text{Ans}$$

b) If $\beta = 540^\circ = 3\pi \text{ rad}$

$$T_2 = T_1 e^{\mu\beta}$$

$$F = 2452.5 e^{0.2(3\pi)}$$

$$F = 15152.32 \text{ N} = 16.2 \text{ kN} \quad \text{Ans}$$

***8-90.** The boat has a weight of 500 lb and is held in position off the side of a ship by the spars at *A* and *B*. A man having a weight of 130 lb gets in the boat, wraps a rope around an overhead boom at *C*, and ties it to the end of the boat as shown. If the boat is disconnected from the spars, determine the *minimum number of half turns* the rope must make around the boom so that the boat can be safely lowered into the water at constant velocity. Also, what is the normal force between the boat and the man? The coefficient of kinetic friction between the rope and the boom is $\mu_k = 0.15$. *Hint:* The problem requires that the normal force between the man's feet and the boat be as small as possible.

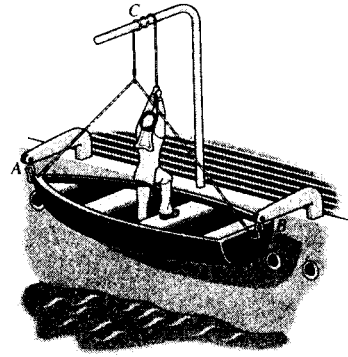

Frictional Force on Flat Belt : If the normal force between the man and the boat is equal to zero, then, $T_1 = 130$ lb and $T_2 = 500$ lb. Applying Eq. 8-6, we have

$$T_2 = T_1 e^{\mu\beta}$$

$$500 = 130e^{0.15\beta}$$

$$\beta = 8.980 \text{ rad}$$

The least number of half turns of the rope required is $\frac{8.980}{\pi} = 2.86$ turns. Thus

Use $n = 3$ half turns Ans

Equations of Equilibrium : From FBD (a),

$$+\uparrow \Sigma F_y = 0; \quad T_2 - N_m - 500 = 0 \quad T_2 = N_m + 500$$

From FBD (b),

$$+\uparrow \Sigma F_y = 0; \quad T_1 + N_m - 130 = 0 \quad T_1 = 130 - N_m$$

Frictional Force on Flat Belts : Here, $\beta = 3\pi$ rad. Applying Eq. 8-6, we have

$$T_2 = T_1 e^{\mu\beta}$$

$$N_m + 500 = (130 - N_m)e^{0.15(3\pi)}$$

$$N_m = 6.74 \text{ lb} \quad \text{Ans}$$

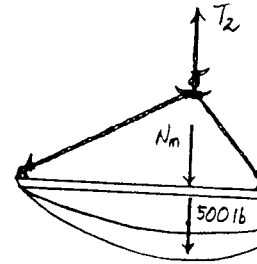

(a)



(b)

8-91. Determine the smallest lever force *P* needed to prevent the wheel from rotating if it is subjected to a torque of $M = 250 \text{ N} \cdot \text{m}$. The coefficient of static friction between the belt and the wheel is $\mu_s = 0.3$. The wheel is pin-connected at its center, *B*.

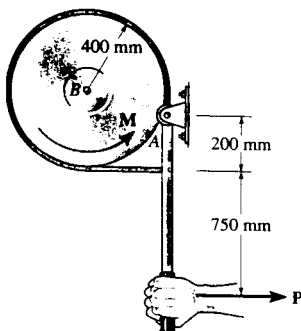

$$(+\Sigma M_A = 0; \quad -F(200) + P(950) = 0$$

$$F = 4.75 P$$

$$T_2 = T_1 e^{\mu\beta}$$

$$F' = 4.75 P e^{0.3(\frac{\pi}{2})} = 19.53 P$$

$$(+\Sigma M_B = 0; \quad -19.53 P(0.4) + 250 + 4.75 P(0.4) = 0$$

$$P = 42.3 \text{ N} \quad \text{Ans}$$

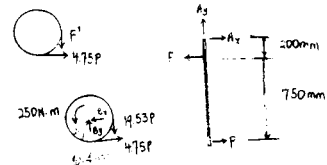

*8-92. Determine the torque M that can be resisted by the band brake if a force of $P = 30 \text{ N}$ is applied to the handle of the lever. The coefficient of static friction between the belt and the wheel is $\mu_s = 0.3$. The wheel is pin-connected at its center, B .

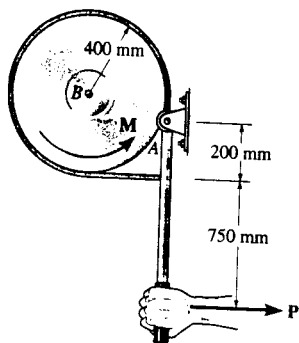

$$\sum M_A = 0;$$

$$-F(200) + 30(950) = 0$$

$$F = 142.5 \text{ N}$$

$$T_2 = T_1 e^{\mu\beta}$$

$$F' = 142.5 e^{0.3(\frac{\pi}{2})} = 585.8 \text{ N}$$

$$\sum M_B = 0;$$

$$-585.8(0.4) + 142.5(0.4) + M = 0$$

$$M = 177 \text{ N}\cdot\text{m} \quad \text{Ans}$$

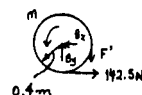
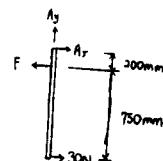

8-93. Blocks A and B weigh 50 lb and 30 lb , respectively. Using the coefficients of static friction indicated, determine the greatest weight of block D without causing motion.

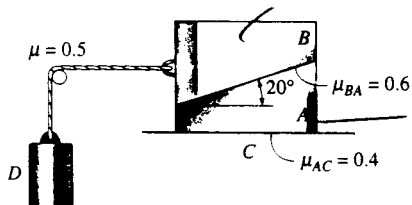

For block A and B : Assuming block B does not slip

$$+\uparrow \Sigma F_y = 0; \quad N_C - (50 + 30) = 0 \quad N_C = 80 \text{ lb}$$

$$\rightarrow \Sigma F_x = 0; \quad 0.4(80) - T_B = 0 \quad T_B = 32 \text{ lb}$$

For block B :

$$+\uparrow \Sigma F_y = 0; \quad N_B \cos 20^\circ + F_B \sin 20^\circ - 30 = 0 \quad [1]$$

$$\rightarrow \Sigma F_x = 0; \quad F_B \cos 20^\circ - N_B \sin 20^\circ - 32 = 0 \quad [2]$$

Solving Eqs. [1] and [2] yields:

$$F_B = 40.32 \text{ lb} \quad N_B = 17.25 \text{ lb}$$

Since $F_B = 40.32 \text{ lb} > \mu N_B = 0.6(17.25) = 10.35 \text{ lb}$, slipping does occur between A and B . Therefore, the assumption is no good.

Since slipping occurs, $F_B = 0.6 N_B$.

$$+\uparrow \Sigma F_y = 0; \quad N_B \cos 20^\circ + 0.6 N_B \sin 20^\circ - 30 = 0 \quad N_B = 26.20 \text{ lb}$$

$$\rightarrow \Sigma F_x = 0; \quad 0.6(26.20) \cos 20^\circ - 26.20 \sin 20^\circ - T_B = 0 \quad T_B = 5.812 \text{ lb}$$

$$T_2 = T_1 e^{\mu\beta} \quad \text{Where} \quad T_2 = W_D, \quad T_1 = T_B = 5.812 \text{ lb}, \quad \beta = 0.5\pi \text{ rad}$$

$$W_D = 5.812 e^{0.5(0.5\pi)}$$

$$= 12.7 \text{ lb}$$

Ans

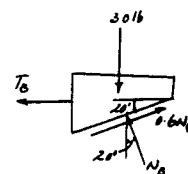
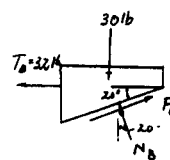
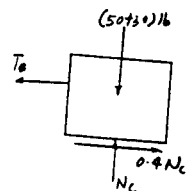

8-94. Blocks *A*, *B* and *D* weigh 75 lb and 30 lb, respectively. Using the coefficients of static friction indicated, determine the frictional force between blocks *A* and *B* and between block *A* and the floor *C*.

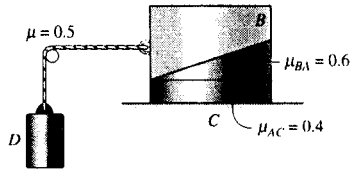

For the rope, $T_2 = T_1 e^{\mu\beta}$, where $T_2 = 30$ lb, $T_1 = T_B$, and $\beta = 0.5\pi$ rad.

$$30 = T_B e^{0.5(0.5\pi)}$$

$$T_B = 13.678 \text{ lb}$$

$$F_C = 13.7 \text{ lb} \quad \text{Ans}$$

For block *B*:

$$+\uparrow \Sigma F_y = 0; N_B \cos 20^\circ + F_B \sin 20^\circ - 75 = 0 \quad [1]$$

$$\rightarrow \Sigma F_x = 0; F_B \cos 20^\circ - N_B \sin 20^\circ - 13.678 = 0 \quad [2]$$

Solving Eqs. [1] and [2] yields:

$$N_B = 65.8 \text{ lb}$$

$$F_B = 38.5 \text{ lb} \quad \text{Ans}$$

Since $F_B = 38.5 \text{ lb} < \mu N_B = 0.6(65.8) = 39.5 \text{ lb}$, slipping between *A* and *B* does not occur.

8-95. Show that the frictional relationship between the belt tensions, the coefficient of friction μ , and the angular contacts α and β for the V-belt is $T_2 = T_1 e^{\mu\beta/\sin(\alpha/2)}$.

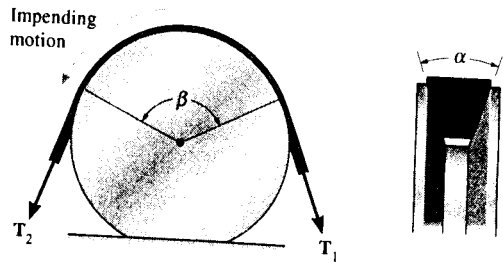
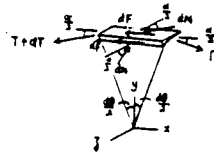

F.B.D of a section of the belt is shown.
Proceeding in the general manner :

$$\Sigma F_x = 0; \quad -(T+dT) \cos \frac{d\theta}{2} + T \cos \frac{d\theta}{2} + 2 dF = 0$$

$$\Sigma F_y = 0; \quad -(T+dT) \sin \frac{d\theta}{2} - T \sin \frac{d\theta}{2} + 2 dN \sin \frac{\alpha}{2} = 0$$

Replace $\sin \frac{d\theta}{2}$ by $\frac{d\theta}{2}$.

$\cos \frac{d\theta}{2}$ by 1,

$$dF = \mu dN$$

Using this and $(dT)(d\theta) \rightarrow 0$, the above relations become

$$dT = 2\mu dN$$

$$T d\theta = 2 \left(dN \sin \frac{\alpha}{2} \right)$$

Combine $\frac{dT}{T} = \mu \frac{d\theta}{\sin \frac{\alpha}{2}}$

Integrate from $\theta = 0, T = T_1$
to $\theta = \beta, T = T_2$

we get,

$$T_2 = T_1 e^{\left(\frac{\mu\beta}{\sin \frac{\alpha}{2}}\right)}$$

Q.E.D

***8-96.** The smooth beam is being hoisted using a rope which is wrapped around the beam and passes through a ring at A as shown. If the end of the rope is subjected to a tension T and the coefficient of static friction between the rope and ring is $\mu_s = 0.3$, determine the angle of θ for equilibrium.

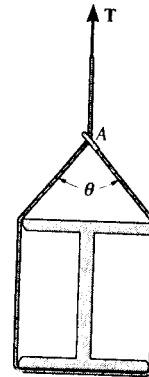

Equation of Equilibrium :

$$+\uparrow \Sigma F_x = 0; \quad T - 2T' \cos \frac{\theta}{2} = 0 \quad T = 2T' \cos \frac{\theta}{2} \quad [1]$$

Frictional Force on Flat Belt : Here, $\beta = \frac{\theta}{2}$, $T_2 = T$ and $T_1 = T'$.

Applying Eq. 8-6 $T_2 = T_1 e^{\mu\beta}$, we have

$$T = T' e^{0.3(\theta/2)} = T' e^{0.15\theta} \quad [2]$$

Substituting Eqs. [1] into [2] yields

$$2T' \cos \frac{\theta}{2} = T' e^{0.15\theta}$$

$$e^{0.15\theta} = 2 \cos \frac{\theta}{2}$$

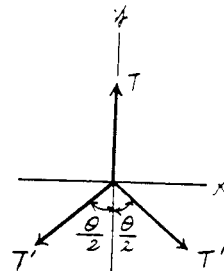

Solving by trial and error

$$\theta = 1.73104 \text{ rad} = 99.2^\circ$$

Ans

8-97. The 20-kg motor has a center of gravity at G and is pin-connected at C to maintain a tension in the drive belt. Determine the smallest counterclockwise twist or torque M that must be supplied by the motor to turn the disk B if wheel A locks and causes the belt to slip over the disk. No slipping occurs at A . The coefficient of static friction between the belt and the disk is $\mu_s = 0.3$.

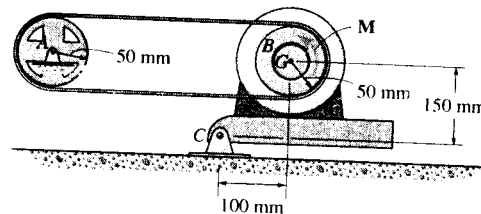

Equations of Equilibrium : From FBD (a),

$$(+\Sigma M_C = 0; \quad T_2(100) + T_1(200) - 196.2(100) = 0 \quad [1]$$

From FBD (b),

$$(+\Sigma M_O = 0; \quad M + T_1(0.05) - T_2(0.05) = 0 \quad [2]$$

Frictional Force on Flat Belt : Here, $\beta = 180^\circ = \pi$ rad. Applying Eq. 8-6, $T_2 = T_1 e^{\mu\beta}$, we have

$$T_2 = T_1 e^{0.3\pi} = 2.5667 T_1 \quad [3]$$

Solving Eqs. [1], [2] and [3] yields

$$M = 3.37 \text{ N} \cdot \text{m} \quad \text{Ans}$$

$$T_1 = 42.97 \text{ N} \quad T_2 = 110.27 \text{ N}$$

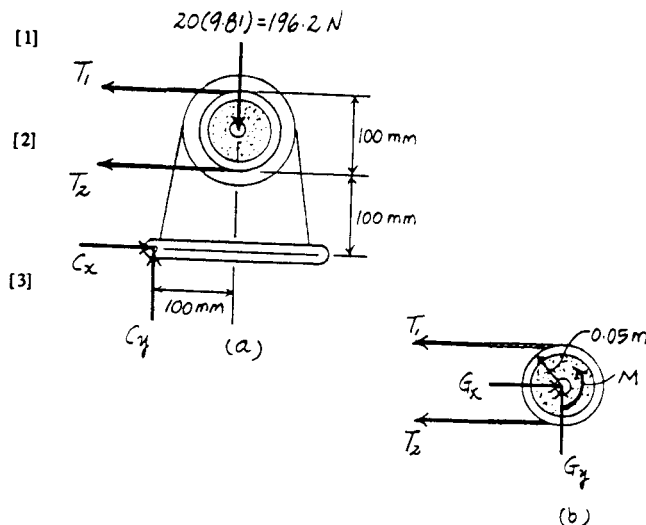

8-98. The simple band brake is constructed so that the ends of the friction strap are connected to the pin at A and the lever arm at B . If the wheel is subjected to a torque of $M = 80 \text{ lb} \cdot \text{ft}$, determine the smallest force P applied to the lever that is required to hold the wheel stationary. The coefficient of static friction between the strap and wheel is $\mu_s = 0.5$.

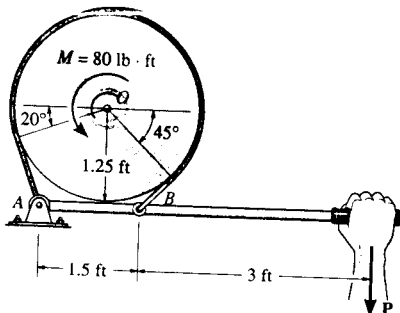

$$\beta = 20^\circ + 180^\circ + 45^\circ = 245^\circ$$

$$\sum M_O = 0; \quad T_1(1.25) + 80 - T_2(1.25) = 0$$

$$T_2 = T_1 e^{\mu_s \beta}; \quad T_2 = T_1 e^{0.5(245^\circ)(\frac{\pi}{180})} = 8.4827T_1$$

Solving;

$$T_1 = 8.553 \text{ lb}$$

$$T_2 = 72.553 \text{ lb}$$

$$\sum M_A = 0; \quad -72.553(\sin 45^\circ)(1.5) - 4.5P = 0$$

$$P = 17.1 \text{ lb} \quad \text{Ans}$$

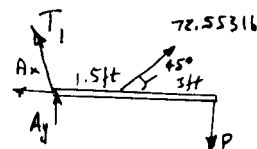
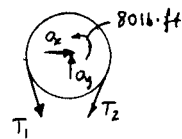

8-99. The cylinder weighs 10 lb and is held in equilibrium by the belt and wall. If slipping does not occur at the wall, determine the minimum vertical force P which must be applied to the belt for equilibrium. The coefficient of static friction between the belt and the cylinder is $\mu_s = 0.25$.

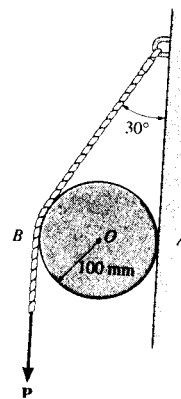

Equations of Equilibrium :

$$\begin{aligned} \sum M_A = 0; \quad & P(0.2) + 10(0.1) - T_2 \cos 30^\circ(0.1 + 0.1 \cos 30^\circ) \\ & - T_2 \sin 30^\circ(0.1 \sin 30^\circ) = 0 \end{aligned} \quad [1]$$

Frictional Force on Flat Belt : Here, $\beta = 30^\circ = \frac{\pi}{6}$ rad and $T_1 = P$.

Applying Eq. 8-6, $T_2 = T_1 e^{\mu_s \beta}$, we have

$$T_2 = P e^{0.25(\pi/6)} = 1.140P \quad [2]$$

Solving Eqs. [1] and [2] yields

$$P = 78.7 \text{ lb} \quad \text{Ans}$$

$$T_2 = 89.76 \text{ lb}$$

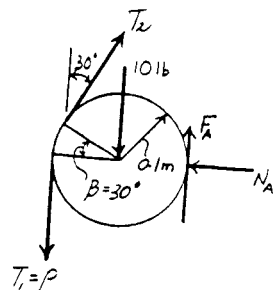

***8-100.** The uniform concrete pipe has a weight of 800 lb and is unloaded slowly from the truck bed using the rope and skids shown. If the coefficient of kinetic friction between the rope and pipe is $\mu_k = 0.3$, determine the force the worker must exert on the rope to lower the pipe at constant speed. There is a pulley at B , and the pipe does not slip on the skids. The lower portion of the rope is parallel to the skids.

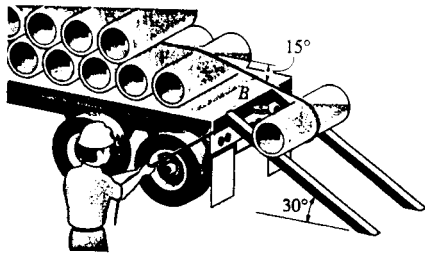

$$\sum M_A = 0; \quad -800(r \sin 30^\circ) + T_2 \cos 15^\circ (r \cos 15^\circ + r \cos 30^\circ) + T_1 \sin 15^\circ (r \sin 15^\circ + r \sin 30^\circ) =$$

$$T_2 = 203.466 \text{ lb}$$

$$\beta = 180^\circ + 15^\circ = 195^\circ$$

$$T_2 = T_1 e^{\mu \beta}, \quad 203.466 = T_1 e^{(0.3)(\frac{195^\circ}{180^\circ})(\pi)}$$

$$T_1 = 73.3 \text{ lb} \quad \text{Ans}$$

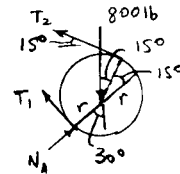

8-101. A cord having a weight of 0.5 lb/ft and a total length of 10 ft is suspended over a peg P as shown. If the coefficient of static friction between the peg and cord is $\mu_s = 0.5$, determine the longest length h which one side of the suspended cord can have without causing motion. Neglect the size of the peg and the length of cord draped over it.



$$T_2 = T_1 e^{\mu \beta} \quad \text{Where } T_2 = 0.5h, T_1 = 0.5(10-h), \beta = \pi \text{ rad}$$

$$0.5h = 0.5(10-h)e^{0.5(\pi)}$$

$$h = 8.28 \text{ ft}$$

Ans

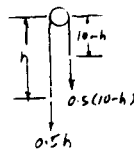

8-102. A conveyer belt is used to transfer granular material and the frictional resistance on the top of the belt is $F = 500$ N. Determine the smallest stretch of the spring attached to the moveable axle of the idle pulley B so that the belt does not slip at the drive pulley A when the torque M is applied. What minimum torque M is required to keep the belt moving? The coefficient of static friction between the belt and the wheel at A is $\mu_s = 0.2$.

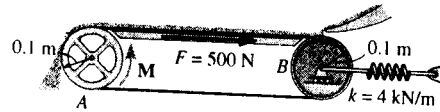

Frictional Force on Flat Belt: Here, $\beta = 180^\circ = \pi$ rad and $T_2 = 500 + T$ and $T_1 = T$. Applying Eq. 8-6, we have

$$\begin{aligned} T_2 &= T_1 e^{\mu\beta} \\ 500 + T &= T e^{0.2\pi} \\ T &= 571.78 \text{ N} \end{aligned}$$

Equations of Equilibrium: From FBD (a),

$$\begin{aligned} \sum M_O = 0; \quad M + 571.78(0.1) - (500 + 571.78)(0.1) &= 0 \\ M &= 50.0 \text{ N}\cdot\text{m} \end{aligned}$$

Ans

From FBD (b),

$$\sum F_x = 0; \quad F_{sp} - 2(571.78) = 0 \quad F_{sp} = 1143.57 \text{ N}$$

Thus, the spring stretch is

$$x = \frac{F_{sp}}{k} = \frac{1143.57}{4000} = 0.2859 \text{ m} = 286 \text{ mm}$$

Ans

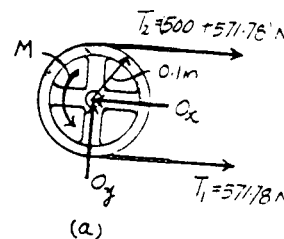

(a)

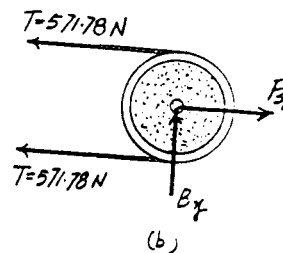

(b)

8-103. Blocks *A* and *B* have a mass of 7 kg and 10 kg, respectively. Using the coefficients of static friction indicated, determine the largest vertical force *P* which can be applied to the cord without causing motion.

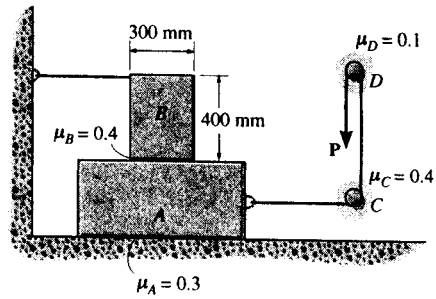

Frictional Forces on Flat Belts : When the cord pass over peg *D*, $\beta = 180^\circ = \pi$ rad and $T_2 = P$. Applying Eq. 8-6, $T_2 = T_1 e^{\mu\beta}$, we have

$$P = T_1 e^{0.1\pi} \quad T_1 = 0.7304P$$

When the cord pass over peg *C*, $\beta = 90^\circ = \frac{\pi}{2}$ rad and $T_2' = T_1 = 0.7304P$. Applying Eq. 8-6, $T_2' = T_1' e^{\mu\beta}$, we have

$$0.7304P = T_1' e^{0.4(\pi/2)} \quad T_1' = 0.3897P$$

Equations of Equilibrium : From FBD (b),

$$+\uparrow \Sigma F_y = 0; \quad N_B - 98.1 = 0 \quad N_B = 98.1 \text{ N}$$

$$\rightarrow \Sigma F_x = 0; \quad F_B - T = 0 \quad [1]$$

$$\curvearrowleft + \Sigma M_O = 0; \quad T(0.4) - 98.1(x) = 0 \quad [2]$$

From FBD (b),

$$+\uparrow \Sigma F_y = 0; \quad N_A - 98.1 - 68.67 = 0 \quad N_A = 166.77 \text{ N}$$

$$\rightarrow \Sigma F_x = 0; \quad 0.3897P - F_B - F_A = 0 \quad [3]$$

Friction : Assuming the block *B* is on the verge of tipping, then $x = 0.15$ m. At for motion to occur, block *A* will have slip. Hence, $F_A = (\mu_s)_A N_A = 0.3(166.77) = 50.031$ N. Substituting these values into Eqs. [1], [2] and [3] and solving yields

$$P = 222.81 \text{ N} = 223 \text{ N} \quad \text{Ans}$$

$$F_B = T = 36.79 \text{ N}$$

Since $(F_B)_{\max} = (\mu_s)_B N_B = 0.4(98.1) = 39.24 \text{ N} > F_B$, block *B* does not slip but tips. Therefore, the above assumption is correct.

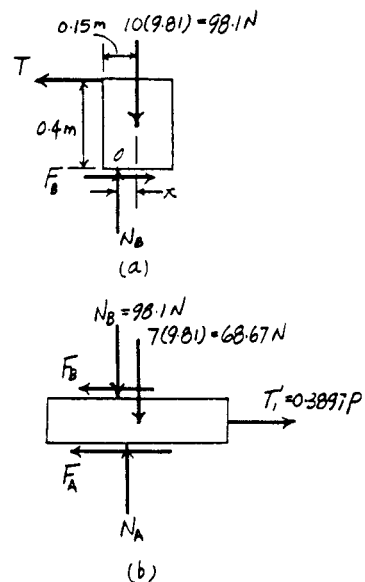

***8-104.** The belt on the portable dryer wraps around the drum D , idler pulley A , and motor pulley B . If the motor can develop a maximum torque of $M = 0.80 \text{ N}\cdot\text{m}$, determine the smallest spring tension required to hold the belt from slipping. The coefficient of static friction between the belt and the drum and motor pulley is $\mu_s = 0.3$.

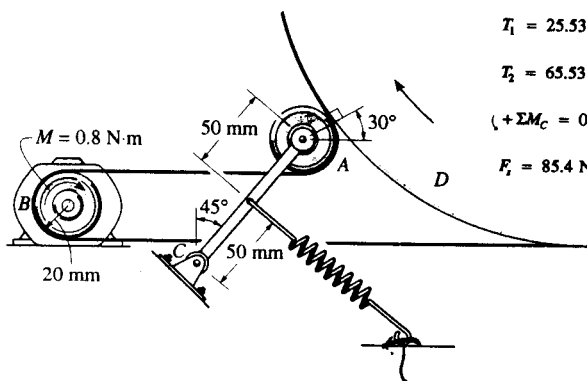

$$\sum M_B = 0; \quad -T_1(0.02) + T_2(0.02) - 0.8 = 0$$

$$T_2 = T_1 e^{\mu\theta}; \quad T_2 = T_1 e^{(0.3)(\pi)} = 2.5663T_1$$

$$T_1 = 25.537 \text{ N}$$

$$T_2 = 65.53 \text{ N}$$

$$\sum M_C = 0; \quad -F_s(0.05) + (25.537 + 25.537 \sin 30^\circ)(0.1 \cos 45^\circ) + 25.537 \cos 30^\circ(0.1 \sin 45^\circ) = 0$$

$$F_s = 85.4 \text{ N} \quad \text{Ans}$$

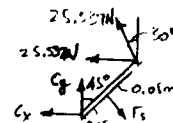
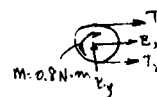

8-105. Block A has a mass of 50 kg and rests on surface B for which $\mu_s = 0.25$. If the coefficient of static friction between the cord and the fixed peg at C is $\mu_s = 0.3$, determine the greatest mass of the suspended cylinder D without causing motion.

Block A :

Assume block A slips and does not tip.

$$+\uparrow \Sigma F_y = 0; \quad N_B + \frac{3}{5}T - 50(9.81) = 0$$

$$\rightarrow \Sigma F_x = 0; \quad 0.25N_B - \frac{4}{5}T = 0$$

$$N_B = 413.1 \text{ N}$$

$$T = 129.1 \text{ N}$$

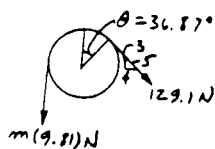

$$\sum M_B = 0; \quad -50(9.81)x + \frac{4}{5}(129.1)(0.3) - \frac{3}{5}(129.1)(0.125 - x) = 0$$

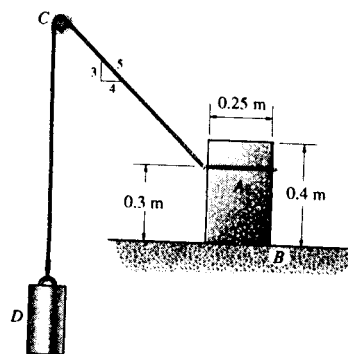

Peg:

$$T_2 = T_1 e^{\mu\theta}; \quad 9.81m = 129.1 e^{0.3 \left(\frac{90^\circ + 36.87^\circ}{180^\circ} \right) \pi}$$

$$m = 25.6 \text{ kg} \quad \text{Ans}$$

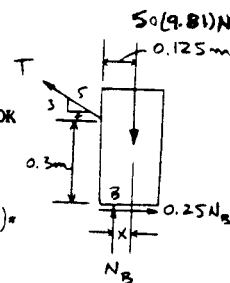

8-106. Block *A* rests on the surface for which $\mu_s = 0.25$. If the mass of the suspended cylinder *D* is 4 kg, determine the smallest mass of block *A* so that it does not slip or tip. The coefficient of static friction between the cord and the fixed peg at *C* is $\mu'_s = 0.3$.

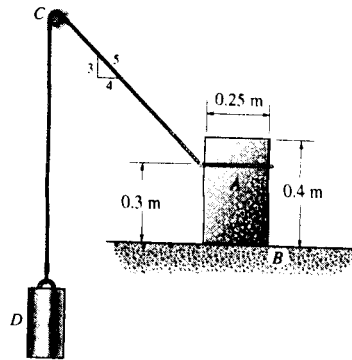

$$T_2 = T_1 e^{\mu\beta}$$

$$4(9.81) = T e^{0.3 \left(\frac{90 + 36.87}{180} \right) \pi}$$

$$T = 20.19 \text{ N}$$

$$\rightarrow \Sigma F_x = 0; \quad F_A - \frac{4}{5}(20.19) = 0$$

$$F_A = 16.152 \text{ N}$$

$$+\uparrow \Sigma F_y = 0; \quad N_A + \frac{3}{5}(20.19) - W = 0$$

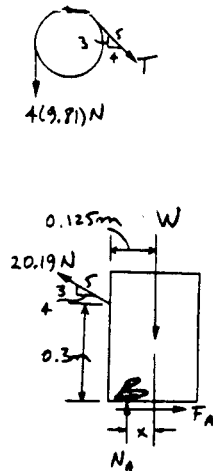

For slipping,

$$(F_A)_{max} = 0.25(N_A); \quad 16.152 \text{ N} = 0.25(N_A)$$

$$N_A = 64.61 \text{ N}, \quad W = 76.72 \text{ N}$$

For tipping, $x = 0.125 \text{ m}$

$$+\Sigma M_B = 0; \quad -W(0.125 \text{ m}) + \frac{4}{5}(20.19)(0.3) = 0$$

$$W = 38.8 \text{ N}$$

Require

$$m = \frac{76.72 \text{ N}}{9.81 \text{ m/s}^2} = 7.82 \text{ kg} \quad \text{Ans}$$

8-107. The collar bearing uniformly supports an axial force of $P = 500 \text{ lb}$. If the coefficient of static friction is $\mu_s = 0.3$, determine the torque M required to overcome friction.

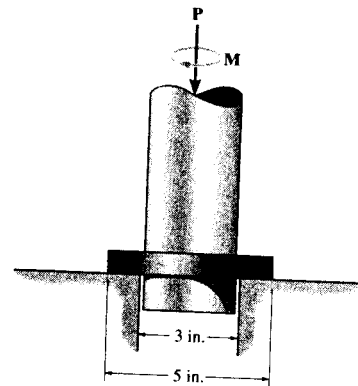

Bearing Friction: Applying Eq. 8-7 with $R_2 = 1.5 \text{ in.}$, $R_1 = 1 \text{ in.}$, $\mu_s = 0.3$ and $P = 500 \text{ lb}$, we have

$$\begin{aligned} M &= \frac{2}{3} \mu_s P \left(\frac{R_2^3 - R_1^3}{R_2^2 - R_1^2} \right) \\ &= \frac{2}{3} (0.3) (500) \left(\frac{1.5^3 - 1^3}{1.5^2 - 1^2} \right) \\ &= 190 \text{ lb} \cdot \text{in} = 15.8 \text{ lb} \cdot \text{ft} \end{aligned}$$

Ans

***8-108.** The collar bearing uniformly supports an axial force of $P = 500$ lb. If a torque of $M = 3$ lb · ft is applied to the shaft and causes it to rotate at constant velocity, determine the coefficient of kinetic friction at the surface of contact.

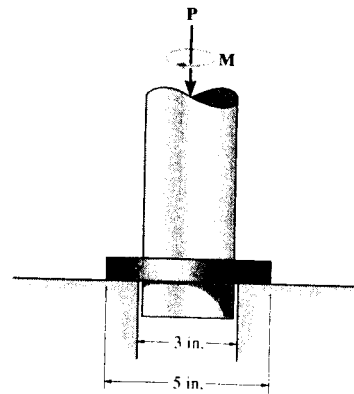

Bearing Friction : Applying Eq. 8-7 with $R_2 = 1.5$ in., $R_1 = 1$ in., $M = 3(12)$ = 36 lb · in and $P = 500$ lb, we have

$$M = \frac{2}{3} \mu_k P \left(\frac{R_2^3 - R_1^3}{R_2^2 - R_1^2} \right)$$

$$36 = \frac{2}{3} (\mu_k) (500) \left(\frac{1.5^3 - 1^3}{1.5^2 - 1^2} \right)$$

$$\mu_k = 0.0568$$

Ans

8-109. The disk clutch is used in standard transmissions of automobiles. If four springs are used to force the two plates *A* and *B* together, determine the force in each spring required to transmit a moment of $M = 600$ lb · ft across the plates. The coefficient of static friction between *A* and *B* is $\mu_s = 0.3$.

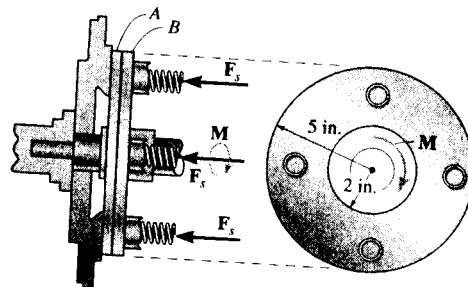

Bearing Friction : Applying Eq. 8-7 with $R_2 = 5$ in., $R_1 = 2$ in., $M = 600(12)$ = 7200 lb · in, $\mu_s = 0.3$ and $P = 4F_{sp}$, we have

$$M = \frac{2}{3} \mu_s P \left(\frac{R_2^3 - R_1^3}{R_2^2 - R_1^2} \right)$$

$$7200 = \frac{2}{3} (0.3) (4F_{sp}) \left(\frac{5^3 - 2^3}{5^2 - 2^2} \right)$$

$$F_{sp} = 1615.38 \text{ lb} = 1.62 \text{ kip}$$

Ans

8-110. The annular ring bearing is subjected to a thrust of 800 lb. If $\mu_s = 0.35$, determine the torque M that must be applied to overcome friction.

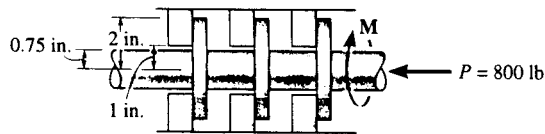

$$M = \frac{2}{3} \mu_s P \left(\frac{R_2^3 - R_1^3}{R_2^2 - R_1^2} \right)$$

$$= \frac{2}{3} (0.35) (800) \left[\frac{(2)^3 - 1^3}{(2)^2 - 1^2} \right]$$

$$= 435.6 \text{ lb}\cdot\text{in.}$$

$$M = 36.3 \text{ lb}\cdot\text{ft} \quad \text{Ans}$$

8-111. The floor-polishing machine rotates at a constant angular velocity. If it has a weight of 80 lb, determine the couple forces F the operator must apply to the handles to hold the machine stationary. The coefficient of kinetic friction between the floor and brush is $\mu_k = 0.3$. Assume the brush exerts a uniform pressure on the floor.

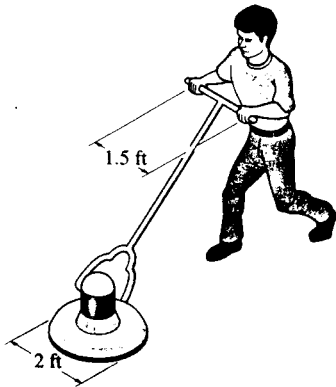

$$M = \frac{2}{3} \mu P R$$

$$F(1.5) = \frac{2}{3} (0.3) (80) (1)$$

$$F = 20.8 \text{ lb} \quad \text{Ans}$$

***8-112.** The plate clutch consists of a flat plate A that slides over the rotating shaft S . The shaft is fixed to the driving plate gear B . If the gear C , which is in mesh with B , is subjected to a torque of $M = 0.8 \text{ N}\cdot\text{m}$, determine the smallest force P , that must be applied via the control arm, to stop the rotation. The coefficient of static friction between the plates A and D is $\mu_s = 0.4$. Assume the bearing pressure between A and D to be uniform.

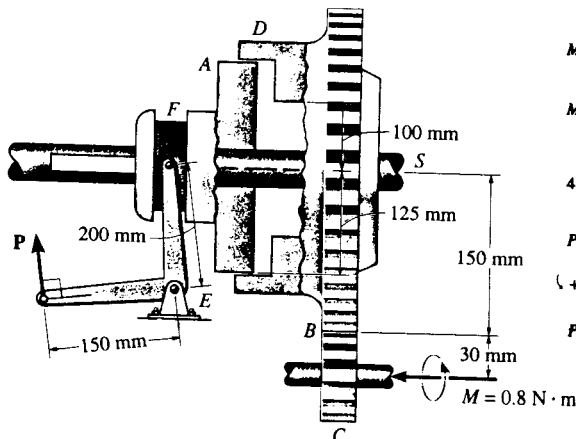

$$F = \frac{0.8}{0.03} = 26.667 \text{ N}$$

$$M = 26.667(0.150) = 4.00 \text{ N}\cdot\text{m}$$

$$M = \frac{2}{3} \mu P' \left(\frac{R_2^3 - R_1^3}{R_2^2 - R_1^2} \right)$$

$$4.00 = \frac{2}{3} (0.4) (P') \left(\frac{(0.125)^3 - (0.1)^3}{(0.125)^2 - (0.1)^2} \right)$$

$$P' = 88.525 \text{ N}$$

$$\sum M_F = 0; \quad 88.525(0.2) - P(0.15) = 0$$

$$P = 118 \text{ N} \quad \text{Ans}$$

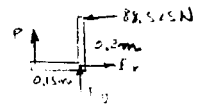
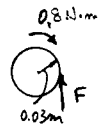

8-113. A tube has a total weight of 200 lb, length $l = 8$ ft, and radius = 0.75 ft. If it rests in sand for which the coefficient of static friction it is $\mu_s = 0.23$, determine the torque M needed to turn it. Assume that the pressure distribution along the length of the tube is defined by $p = p_0 \sin \theta$. For the solution it is necessary to determine p_0 , the peak pressure, in terms of the weight and tube dimensions.

Equations of Equilibrium and Friction: Here, $dN = p l r d\theta = p_0 l r \sin \theta d\theta$. Since the tube is on the verge of slipping, $dF = \mu_s dN = p_0 \mu_s l r \sin \theta d\theta$.

$$+\uparrow \Sigma F_y = 0; \quad 2 \int_0^{\frac{\pi}{2}} dN \sin \theta - W = 0$$

$$2 \int_0^{\frac{\pi}{2}} p_0 l r \sin^2 \theta d\theta = W$$

$$p_0 l r \int_0^{\frac{\pi}{2}} (1 - \cos 2\theta) d\theta = W$$

$$p_0 l r \left(\frac{\pi}{2} \right) = W$$

$$p_0 = \frac{2W}{\pi l r} \quad [1]$$

$$\zeta + \Sigma M_O = 0; \quad 2 \int_0^{\frac{\pi}{2}} dF(r) - M = 0$$

$$M = 2 \int_0^{\frac{\pi}{2}} p_0 \mu_s l r^2 \sin \theta d\theta = 2 p_0 \mu_s l r^2 \quad [2]$$

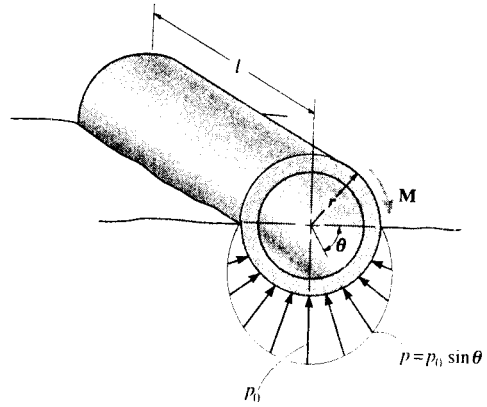

Substituting Eq. [1] into [2] yields

$$M = \frac{4W\mu_s r}{\pi}$$

However, $W = 200$ lb, $\mu_s = 0.23$ and $r = 0.75$ ft, then

$$M = \frac{4(200)(0.23)(0.75)}{\pi} = 43.9 \text{ lb} \cdot \text{ft} \quad \text{Ans}$$

8-114. Because of wearing at the edges, the pivot bearing is subjected to a conical pressure distribution at its surface of contact. Determine the torque M required to overcome friction and turn the shaft, which supports an axial force P . The coefficient of static friction is μ_s . For the solution, it is necessary to determine the peak pressure p_0 in terms of P and the bearing radius R .

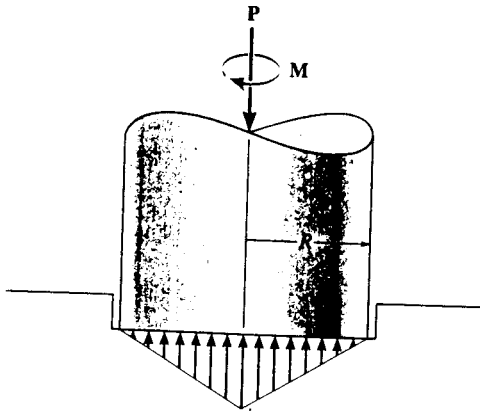

$$dM = r dF = r \mu dN = r \mu p dA = r \mu p (r d\theta dr)$$

$$M = \int dM = \int_0^R \mu \left(p_0 - \frac{p_0}{R} r \right) r^2 dr \int_0^{2\pi} d\theta$$

$$= \frac{\pi}{6} \mu p_0 R^3$$

$$P = \int p dA = \int_0^R \left(p_0 - \frac{p_0}{R} r \right) r dr \int_0^{2\pi} d\theta$$

$$= \frac{\pi}{3} p_0 R^2$$

Thus, $M = \frac{1}{2} \mu PR$ Ans

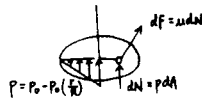

8-115. The pivot bearing is subjected to a pressure distribution at its surface of contact which varies as shown. If the coefficient of static friction is μ , determine the torque M required to overcome friction if the shaft supports an axial force P .

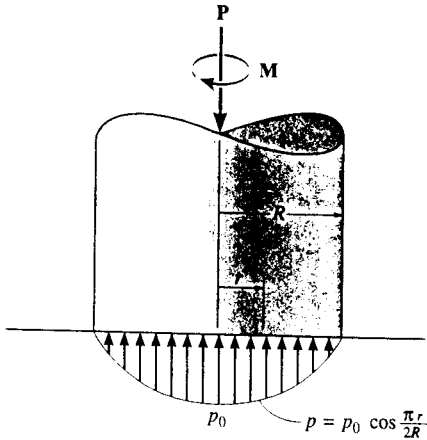

$$dF = \mu dN = \mu p_0 \cos\left(\frac{\pi r}{2R}\right) dA$$

$$M = \int_A r \mu p_0 \cos\left(\frac{\pi r}{2R}\right) r dr d\theta$$

$$= \mu p_0 \int_0^R \left(r^2 \cos\left(\frac{\pi r}{2R}\right) dr\right) \int_0^{2\pi} d\theta$$

$$= \mu p_0 \left[\frac{2r}{\left(\frac{\pi}{2R}\right)^2} \cos\left(\frac{\pi r}{2R}\right) + \frac{\left(\frac{\pi}{2R}\right)^2 r^2 - 2}{\left(\frac{\pi}{2R}\right)^3} \sin\left(\frac{\pi r}{2R}\right) \right]_0^R (2\pi)$$

$$= \mu p_0 \left(\frac{16R^3}{\pi^2}\right) \left[\left(\frac{\pi}{2}\right)^2 - 2\right]$$

$$= 0.7577 \mu p_0 R^3$$

$$P = \int_A dN = \int_0^R p_0 \left(\cos\left(\frac{\pi r}{2R}\right) r dr\right) \int_0^{2\pi} d\theta$$

$$= p_0 \left[\frac{1}{\left(\frac{\pi}{2R}\right)^2} \cos\left(\frac{\pi r}{2R}\right) + \frac{r}{\left(\frac{\pi}{2R}\right)} \sin\left(\frac{\pi r}{2R}\right) \right]_0^R (2\pi)$$

$$= 4p_0 R^2 \left(1 - \frac{2}{\pi}\right)$$

$$= 1.454 p_0 R^2$$

Thus,

$$M = 0.521 P \mu R \quad \text{Ans}$$

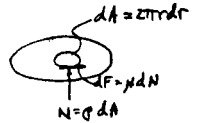

*8-116. The tractor is used to push the 1500-lb pipe. To do this it must overcome the frictional forces at the ground, caused by sand. Assuming that the sand exerts a pressure on the bottom of the pipe as shown, and the coefficient of static friction between the pipe and the sand is $\mu_s = 0.3$, determine the force required to push the pipe forward. Also, determine the peak pressure p_0 .

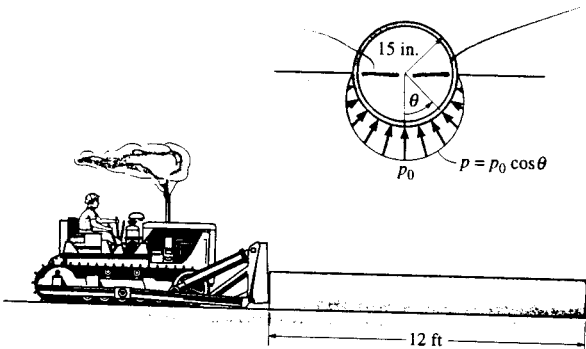

$$+\uparrow \Sigma F_y = 0; \quad 2l \int_0^{\pi/2} p_0 \cos \theta (r d\theta) \cos \theta - W = 0$$

$$2p_0 l r \int_0^{\pi/2} \cos^2 \theta d\theta = W$$

$$2p_0 r l \left(\frac{1}{2}\theta + \frac{1}{4}\sin 2\theta\right) \Big|_0^{\pi/2} = W$$

$$2(p_0) r l \left(\frac{\pi}{4}\right) = W$$

$$2 p_0 (15)(12)(12) \left(\frac{\pi}{4}\right) = 1500$$

$$p_0 = 0.442 \text{ psi} \quad \text{Ans}$$

$$F = \int_{-\pi/2}^{\pi/2} (0.3)(0.442 \text{ lb/in}^2)(12 \text{ ft})(12 \text{ in./ft})(15 \text{ in.}) d\theta$$

$$F = 573 \text{ lb} \quad \text{Ans}$$

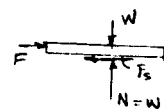

8-117. A 200-mm diameter post is driven 3 m into sand for which $\mu_s = 0.3$. If the normal pressure acting completely around the post varies linearly with depth as shown, determine the frictional torque M that must be overcome to rotate the post.

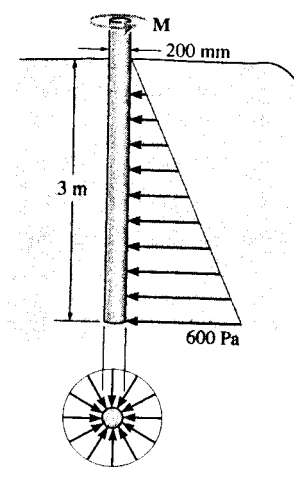

Equations of Equilibrium and Friction : The resultant normal force on the post is $N = \frac{1}{2}(600+0)(3)(\pi)(0.2) = 180\pi$ N. Since the post is on the verge of rotating, $F = \mu_s N = 0.3(180\pi) = 54.0\pi$ N.

$$\begin{aligned} \left(+\Sigma M_O = 0; \quad M - 54.0\pi(0.1) = 0 \right. \\ \left. M = 17.0 \text{ N}\cdot\text{m} \right. \end{aligned} \quad \text{Ans}$$

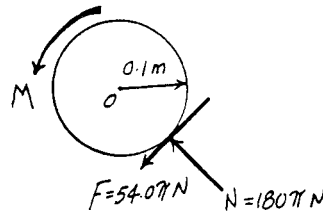

8-118. A pulley having a diameter of 80 mm and mass of 1.25 kg is supported loosely on a shaft having a diameter of 20 mm. Determine the torque M that must be applied to the pulley to cause it to rotate with constant motion. The coefficient of kinetic friction between the shaft and pulley is $\mu_k = 0.4$. Also calculate the angle θ which the normal force at the point of contact makes with the horizontal. The shaft itself cannot rotate.

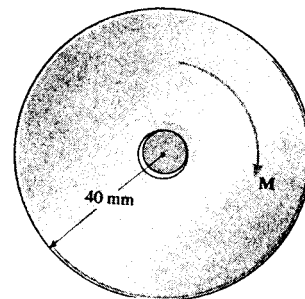

Frictional Force on Journal Bearing : Here, $\phi_k = \tan^{-1}\mu_k = \tan^{-1}0.4 = 21.80^\circ$. Then the radius of friction circle is $r_f = r \sin \phi_k = 0.01 \sin 21.80^\circ = 3.714(10^{-3})$ m. The angle for which the normal force makes with horizontal is

$$\theta = 90^\circ - \phi_k = 68.2^\circ \quad \text{Ans}$$

Equations of Equilibrium :

$$+\uparrow \Sigma F_y = 0; \quad R - 12.2625 = 0 \quad R = 12.2625 \text{ N}$$

$$\left(+\Sigma M_O = 0; \quad 12.2625(3.714)(10^{-3}) - M = 0 \right. \\ \left. M = 0.0455 \text{ N}\cdot\text{m} \right. \quad \text{Ans}$$

$$1.25(9.81) = 12.2625 \text{ N}$$

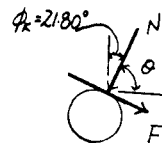
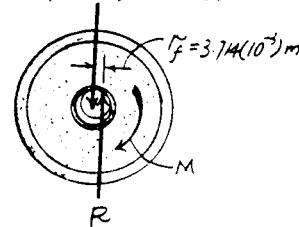

8-119. The pulley has a radius of 3 in. and fits loosely on the 0.5-in.-diameter shaft. If the loadings acting on the belt cause the pulley to rotate with constant angular velocity, determine the frictional force between the shaft and the pulley and compute the coefficient of kinetic friction. The pulley weighs 18 lb.

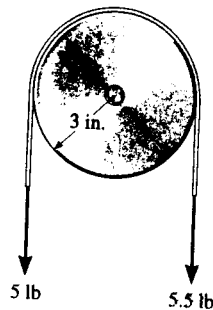

$$+\uparrow \Sigma F_y = 0; \quad R - 18 - 10.5 = 0$$

$$R = 28.5 \text{ lb}$$

$$\zeta + \Sigma M_O = 0; \quad -5.5(3) + 5(3) + 28.5 r_f = 0$$

$$r_f = 0.05263 \text{ in.}$$

$$r_f = r \sin \phi_k$$

$$0.05263 = \frac{0.5}{2} \sin \phi_k$$

$$\phi_k = 12.15^\circ$$

$$\mu = \tan \phi_k = \tan 12.15^\circ = 0.215 \quad \text{Ans}$$

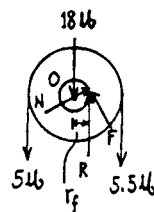

Note also by approximation,

$$r_f = r \mu$$

$$0.05263 = \frac{0.5}{2} \mu$$

$$\mu = 0.211 \quad \text{Ans} \quad (\text{approx.})$$

Also,

$$\zeta + \Sigma M_O = 0; \quad -5.5(3) + 5(3) + F\left(\frac{0.5}{2}\right) = 0$$

$$F = 6 \text{ lb} \quad \text{Ans}$$

$$N = \sqrt{R^2 - F^2} = \sqrt{(28.5)^2 - 6^2} = 27.86 \text{ lb}$$

$$\mu = \frac{F}{N} = \frac{6}{27.86} = 0.215 \quad \text{Ans}$$

***8-120.** The pulley has a radius of 3 in. and fits loosely on the 0.5-in.-diameter shaft. If the loadings acting on the belt cause the pulley to rotate with constant angular velocity, determine the frictional force between the shaft and the pulley and compute the coefficient of kinetic friction. Neglect the weight of the pulley.

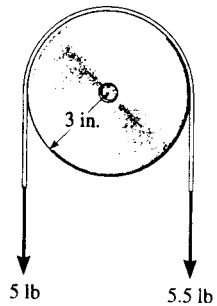

$$\begin{aligned}
 +\uparrow \Sigma F_y &= 0; & R - 5 - 5.5 &= 0 \\
 & & R &= 10.5 \text{ lb} \\
 \curvearrowright +\Sigma M_O &= 0; & -5.5(3) + 5(3) + F(0.25) &= 0 \\
 & & F &= 6 \text{ lb} & \text{Ans} \\
 & & N &= \sqrt{(10.5)^2 - 6^2} = 8.617 \text{ lb} \\
 & & \mu_k &= \frac{F}{N} = \frac{6}{8.617} = 0.696 & \text{Ans}
 \end{aligned}$$

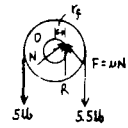

Also,

$$\begin{aligned}
 \curvearrowright +\Sigma M_O &= 0; & -5.5(3) + 5(3) + 10.5(r_f) &= 0 \\
 & & r_f &= 0.1429 \text{ in.} \\
 & & 0.1429 &= \frac{0.5}{2} \sin \phi_k \\
 & & \phi_k &= 34.85^\circ \\
 & & \mu_k &= \tan 34.85^\circ = 0.696 & \text{Ans}
 \end{aligned}$$

By approximation,

$$\begin{aligned}
 r_f &= r \mu_k \\
 \mu_k &= \frac{0.1429}{0.25} = 0.571 & \text{Ans} & \quad (\text{approx.})
 \end{aligned}$$

8-121. Determine the tension **T** in the belt needed to overcome the tension of 200 lb created on the other side. Also, what are the normal and frictional components of force developed on the collar bushing? The coefficient of static friction is $\mu_s = 0.21$.

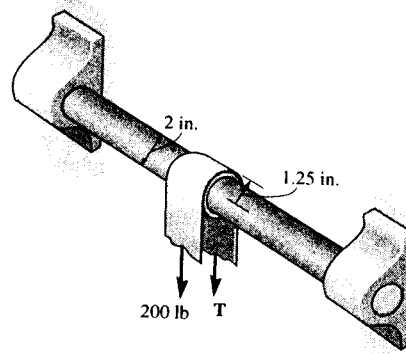

Frictional Force on Journal Bearing: Here, $\phi_s = \tan^{-1} \mu_s = \tan^{-1} 0.21 = 11.86^\circ$. Then the radius of friction circle is

$$r_f = r \sin \phi_s = 1.25 \sin 11.86^\circ = 0.2055 \text{ in.}$$

Equations of Equilibrium:

$$\begin{aligned}
 \curvearrowright +\Sigma M_P &= 0; & 200(1.125 + 0.2055) - T(1.125 - 0.2055) &= 0 \\
 & & T &= 289.41 \text{ lb} = 289 \text{ lb} & \text{Ans}
 \end{aligned}$$

$$+\uparrow F_y = 0; \quad R - 200 - 289.4 = 0 \quad R = 489.41 \text{ lb}$$

Thus, the normal and friction force are

$$\begin{aligned}
 N &= R \cos \phi_s = 489.41 \cos 11.86^\circ = 479 \text{ lb} & \text{Ans} \\
 F &= R \sin \phi_s = 489.41 \sin 11.86^\circ = 101 \text{ lb} & \text{Ans}
 \end{aligned}$$

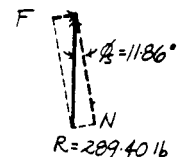
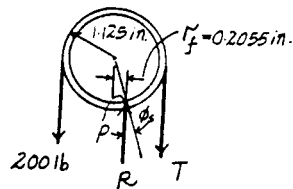

8-122. If a tension force $T = 215$ lb is required to pull the 200-lb force around the collar bushing, determine the coefficient of static friction at the contacting surface. The belt does not slip on the collar.

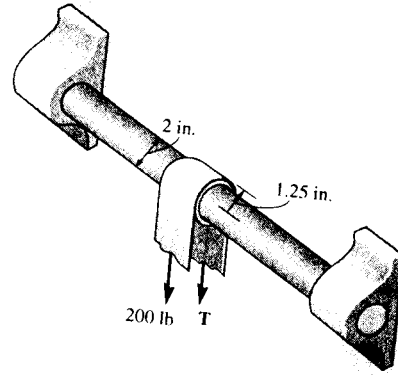

Equation of Equilibrium :

$$\begin{aligned} \left(+\Sigma M_p = 0; \quad 200(1.125 + r_f) - 215(1.125 - r_f) = 0 \right. \\ \left. r_f = 0.04066 \text{ in.} \right. \end{aligned}$$

Frictional Force on Journal Bearing : The radius of friction circle is

$$\begin{aligned} r_f &= r \sin \phi_k \\ 0.04066 &= 1 \sin \phi_k \\ \phi_k &= 2.330^\circ \end{aligned}$$

and the coefficient of static friction is

$$\mu_s = \tan \phi_s = \tan 2.330^\circ = 0.0407$$

Ans

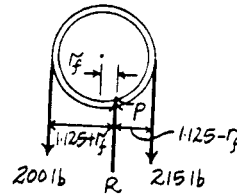

8-123. A disk having an outer diameter of 120 mm fits loosely over a fixed shaft having a diameter of 30 mm. If the coefficient of static friction between the disk and the shaft is $\mu_s = 0.15$ and the disk has a mass of 50 kg, determine the smallest vertical force F acting on the rim which must be applied to the disk to cause it to slip over the shaft.

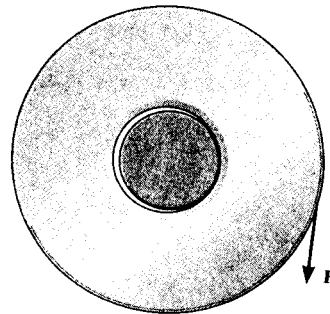

Frictional Force on Journal Bearing : Here, $\phi_s = \tan^{-1} \mu_s = \tan^{-1} 0.15 = 8.531^\circ$. Then the radius of friction circle is

$$r_f = r \sin \phi_s = 0.015 \sin 8.531^\circ = 2.225 (10^{-3}) \text{ m}$$

Equation of Equilibrium :

$$\begin{aligned} \left(+\Sigma M_p = 0; \quad 490.5(2.225) (10^{-3}) - F[0.06 - (2.225) (10^{-3})] = 0 \right. \\ \left. F = 18.9 \text{ N} \right. \end{aligned}$$

Ans

***8-124.** The weight of the body on the tibiotalar joint J is 125 lb. If the radius of curvature of the talus surface of the ankle is 1.40 in., and the coefficient of static friction between the bones is $\mu_s = 0.1$, determine the force T developed in the Achilles tendon necessary to rotate the joint.

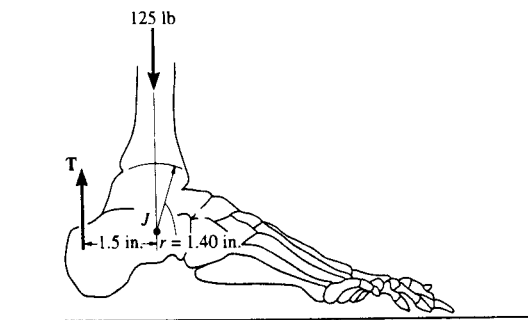

With the addition of force T , the resultant force $W + T$ acts a distance x horizontally from W .

$$F_{Rx} = \Sigma M_O; \quad -(W+T)x = -Ta \quad x = \frac{Ta}{W+T}$$

Friction:

$$\tan \phi = \frac{\mu N}{N} = \mu$$

However, from geometry r is the radius of curvature.

$$\sin \phi = \frac{x}{r}$$

Since ϕ is small $\sin \phi = \tan \phi = \mu = \frac{x}{r}$, substitute $x = \frac{Ta}{W+T}$ yields

$$\mu = \frac{Ta}{r(W+T)}$$

$$T = \frac{\mu r W}{a - \mu r}$$

Here $W = 125$ lb, $r = 1.40$ in, $\mu = 0.1$, $a = 1.50$ in.

$$T = \frac{0.1(1.40)(125)}{1.50 - 0.1(1.40)}$$

$$= 12.9 \text{ lb} \quad \text{Ans}$$

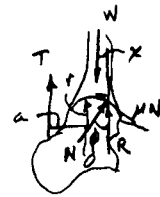

8-125. The collar fits *loosely* around a fixed shaft that has a radius of 2 in. If the coefficient of kinetic friction between the shaft and the collar is $\mu_k = 0.3$, determine the force P on the horizontal segment of the belt so that the collar rotates counterclockwise with a constant angular velocity. Assume that the belt does not slip on the collar; rather, the collar slips on the shaft. Neglect the weight and thickness of the belt and collar. The radius, measured from the center of the collar to the mean thickness of the belt, is 2.25 in.

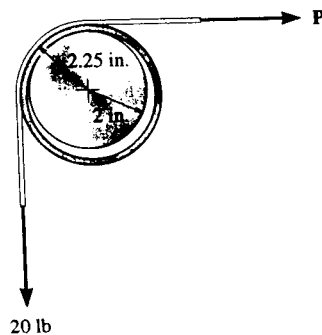

$$\phi_k = \tan^{-1} \mu_k = \tan^{-1} 0.3 = 16.699^\circ$$

$$r_f = 2 \sin 16.699^\circ = 0.5747 \text{ in.}$$

Equilibrium:

$$+\uparrow \Sigma F_y = 0; \quad R_y - 20 = 0 \quad R_y = 20 \text{ lb}$$

$$+\rightarrow \Sigma F_x = 0; \quad T - R_x = 0 \quad R_x = T$$

$$\text{Hence} \quad R = \sqrt{R_x^2 + R_y^2} = \sqrt{T^2 + 20^2}$$

$$(+ \Sigma M_O = 0; \quad -(\sqrt{T^2 + 20^2})(0.5747) + 20(2.25) - T(2.25) = 0$$

$$\text{Choose the smallest root} \quad T = 13.8 \text{ lb} \quad \text{Ans}$$

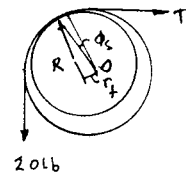

8-126. The collar fits *loosely* around a fixed shaft that has a radius of 2 in. If the coefficient of kinetic friction between the shaft and the collar is $\mu_k = 0.3$, determine the force P on the horizontal segment of the belt so that the collar rotates clockwise with a constant angular velocity. Assume that the belt does not slip on the collar; rather, the collar slips on the shaft. Neglect the weight and thickness of the belt and collar. The radius, measured from the center of the belt and collar, to the mean thickness of the belt, is 2.25 in.

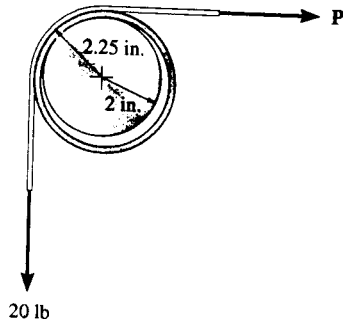

$$\phi_k = \tan^{-1} \mu_k = \tan^{-1} 0.3 = 16.699^\circ$$

$$r_f = 2 \sin 16.699^\circ = 0.5747 \text{ in.}$$

Equilibrium:

$$+\uparrow \Sigma F_y = 0; \quad R_y - 20 = 0 \quad R_y = 20 \text{ lb}$$

$$+\rightarrow \Sigma F_x = 0; \quad T - R_x = 0 \quad R_x = T$$

$$\text{Hence} \quad R = \sqrt{R_x^2 + R_y^2} = \sqrt{T^2 + 20^2}$$

$$(+\Sigma M_o = 0; \quad (\sqrt{T^2 + 20^2})(0.5747) + 20(2.25) - T(2.25) = 0$$

$$\text{Choose the largest root} \quad T = 29.0 \text{ lb} \quad \text{Ans}$$

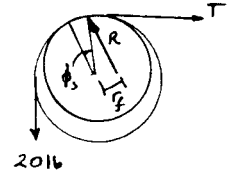

8-127. The connecting rod is attached to the piston by a 0.75-in.-diameter pin at B and to the crank shaft by a 2-in.-diameter bearing A . If the piston is moving downwards, and the coefficient of static friction at these points is $\mu_s = 0.2$, determine the radius of the friction circle at each connection.

$$(r_f)_A = r_A \mu_s = 0.2 \text{ in.} \quad \text{Ans}$$

$$(r_f)_B = r_B \mu_s = \frac{0.75(0.2)}{2} = 0.075 \text{ in.} \quad \text{Ans}$$

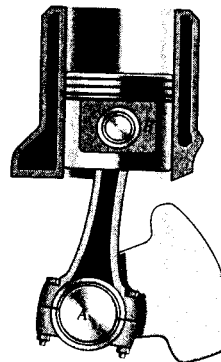

***8-128.** The connecting rod is attached to the piston by a 20-mm-diameter pin at B and to the crank shaft by a 50-mm-diameter bearing A . If the piston is moving upwards, and the coefficient of static friction at these points is $\mu_s = 0.3$, determine the radius of the friction circle at each connection.

$$(r_f)_A = r_A \mu_s = 25(0.3) = 7.50 \text{ mm} \quad \text{Ans}$$

$$(r_f)_B = r_B \mu_s = 10(0.3) = 3 \text{ mm} \quad \text{Ans}$$

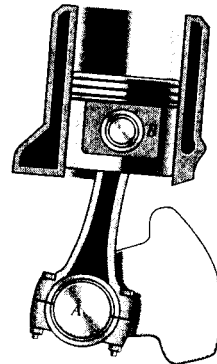

8-129. The vehicle has a weight of 2600 lb and center of gravity at G . Determine the horizontal force P that must be applied to overcome the rolling resistance of the wheels. The coefficient of rolling resistance is 0.5 in. The tires have a diameter of 2.75 ft.

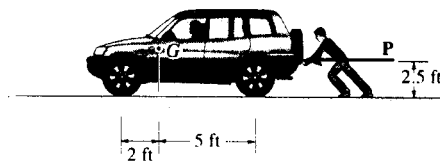

Equations of Equilibrium :

$$\begin{aligned} \sum M_A = 0; \quad N_B(7) + P(2.5) - 2600(2) &= 0 \\ N_B &= \frac{5200 - 2.5P}{7} \end{aligned}$$

$$\begin{aligned} \sum M_B = 0; \quad P(2.5) + 2600(5) - N_A(7) &= 0 \\ N_A &= \frac{13000 + 2.5P}{7} \end{aligned}$$

Rolling Resistance : Here, $W = N_A + N_B = \frac{5200 - 2.5P}{7} + \frac{13000 + 2.5P}{7}$
 $= 2600$ lb, $a = 0.5$ in. and $r = \left(\frac{2.75}{2}\right)(12) = 16.5$ in.. Applying Eq. 8 - 11,
 we have

$$\begin{aligned} P &= \frac{Wa}{r} \\ &= \frac{2600(0.5)}{16.5} \\ &= 78.8 \text{ lb} \end{aligned}$$

Ans

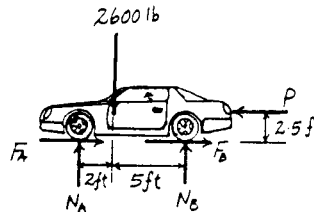

8-130. The hand cart has wheels with a diameter of 80 mm. If a crate having a mass of 500 kg is placed on the cart so that each wheel carries an equal load, determine the horizontal force P that must be applied to the handle to overcome the rolling resistance. The coefficient of rolling resistance is 2 mm. Neglect the mass of the cart.

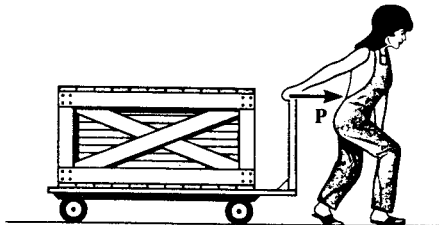

$$\begin{aligned} P &= \frac{Wa}{r} \\ &= 500(9.81)\left(\frac{2}{40}\right) \\ P &= 245 \text{ N} \end{aligned}$$

Ans

8-131. The cylinder is subjected to a load that has a weight W . If the coefficients of rolling resistance for the cylinder's top and bottom surfaces are a_A and a_B , respectively, show that a force having a magnitude of $P = [W(a_A + a_B)]/2r$ is required to move the load and thereby roll the cylinder forward. Neglect the weight of the cylinder.

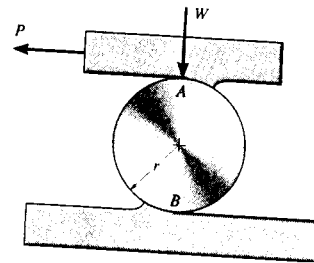

$$\begin{aligned} \rightarrow \Sigma F_x = 0: & \quad (R_A)_x - P = 0 & \quad (R_A)_x = P \\ + \uparrow \Sigma F_y = 0: & \quad (R_A)_y - W = 0 & \quad (R_A)_y = W \end{aligned}$$

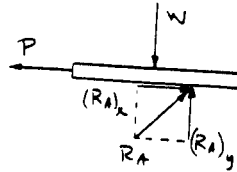

$$\left(+ \Sigma M_B = 0: \quad P(r \cos \phi_A + r \cos \phi_B) - W(a_A + a_B) = 0 \quad (1) \right.$$

Since ϕ_A and ϕ_B are very small, $\cos \phi_A = \cos \phi_B = 1$. Hence, from Eq. (1)

$$P = \frac{W(a_A + a_B)}{2r} \quad (\text{QED})$$

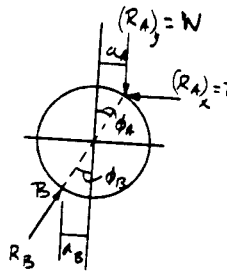

*8-132. A large crate having a mass of 200 kg is moved along the floor using a series of 150-mm-diameter rollers for which the coefficient of rolling resistance is 3 mm at the ground and 7 mm at the bottom surface of the crate. Determine the horizontal force P needed to push the crate forward at a constant speed. *Hint:* Use the result of Prob. 8-131.

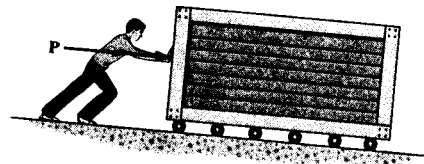

Rolling Resistance: Applying the result obtained in Prob. 8-131,

$$P = \frac{W(a_A + a_B)}{2r}, \text{ with } a_A = 7 \text{ mm}, a_B = 3 \text{ mm}, W = 200(9.81) = 1962 \text{ N}, \text{ and } r = 75 \text{ mm, we have}$$

$$P = \frac{1962(7+3)}{2(75)} = 130.8 \text{ N} = 131 \text{ N} \quad \text{Ans}$$

8-133. The lawn roller weighs 300 lb. If the rod BA is held at an angle of 30° from the horizontal and the coefficient of rolling resistance for the roller is 2 in., determine the force F needed to push the roller at constant speed. Neglect friction developed at the axle and assume that the resultant force acting on the handle is applied along BA .

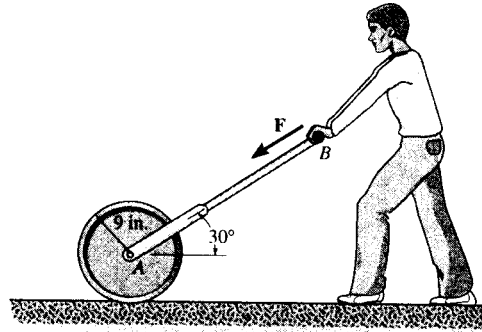

Rolling Resistance : The angle $\theta = \sin^{-1} \frac{2}{9} = 12.84^\circ$. From the equilibrium of the lawn roller, we have

$$\rightarrow \Sigma F_x = 0; \quad R \sin 12.84^\circ - F \cos 30^\circ = 0 \quad [1]$$

$$+ \uparrow \Sigma F_y = 0; \quad R \cos 12.84^\circ - 300 - F \sin 30^\circ = 0 \quad [2]$$

Solving Eq.[1] and [2]

$$F = 90.9 \text{ lb} \quad \text{Ans}$$

$$R = 354.31 \text{ lb}$$

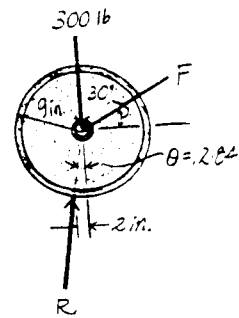

8-134. A single force P is applied to the handle of the drawer. If friction is neglected at the bottom side and the coefficient of static friction along the sides is $\mu_s = 0.4$, determine the largest spacing s between the symmetrically placed handles so that the drawer does not bind at the corners A and B when the force P is applied to one of the handles.

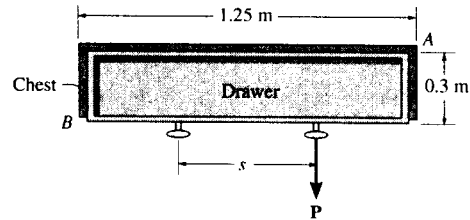

Equations of Equilibrium and Friction : If the drawer does not bind at corners A and B , slipping would have to occur at points A and B . Hence, $F_A = \mu N_A = 0.4N_A$ and $F_B = \mu N_B = 0.4N_B$.

$$\rightarrow \Sigma F_x = 0; \quad N_B - N_A = 0 \quad N_A = N_B = N$$

$$+ \uparrow \Sigma F_y = 0; \quad 0.4N + 0.4N - P = 0 \quad P = 0.8N$$

$$\begin{aligned} + \Sigma M_B = 0; \quad N(0.3) + 0.4N(1.25) - 0.8N\left(\frac{s+1.25}{2}\right) &= 0 \\ N\left[0.3 + 0.5 - 0.8\left(\frac{s+1.25}{2}\right)\right] &= 0 \end{aligned}$$

- Since $N \neq 0$, then

$$0.3 + 0.5 - 0.8\left(\frac{s+1.25}{2}\right) = 0$$

$$s = 0.750 \text{ m} \quad \text{Ans}$$

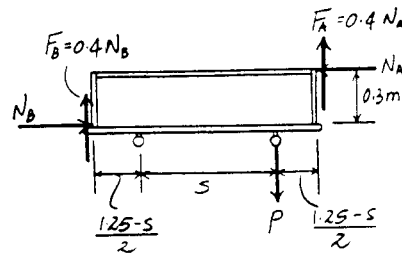

8-135. The truck has a mass of 1.25 Mg and a center of mass at G . Determine the greatest load it can pull if (a) the truck has rear-wheel drive while the front wheels are free to roll, and (b) the truck has four-wheel drive. The coefficient of static friction between the wheels and the ground is $\mu_s = 0.5$, and between the crate and the ground, it is $\mu_c = 0.4$.

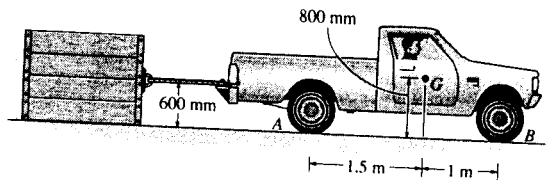

a) The truck with rear wheel drive.

Equations of Equilibrium and Friction: It is required that the rear wheels of the truck slip. Hence $F_A = \mu_s N_A = 0.5N_A$. From FBD (a),

$$\left(+ \Sigma M_B = 0; \quad 1.25(10^3)(9.81)(1) + T(0.6) - N_A(2.5) = 0 \quad [1] \right.$$

$$\left. \begin{aligned} \rightarrow \Sigma F_x = 0; \quad 0.5N_A - T = 0 \end{aligned} \quad [2] \right.$$

Solving Eqs. [1] and [2] yields

$$N_A = 5573.86 \text{ N} \quad T = 2786.93 \text{ N}$$

Since the crate moves, $F_C = \mu_c N_C = 0.4N_C$. From FBD (c),

$$+ \uparrow \Sigma F_y = 0; \quad N_C - W = 0 \quad N_C = W$$

$$\begin{aligned} \rightarrow \Sigma F_x = 0; \quad 2786.93 - 0.4W = 0 \\ W = 6967.33 \text{ N} = 6.97 \text{ kN} \end{aligned}$$

Ans

b) The truck with four wheel drive.

Equations of Equilibrium and Friction: It is required that the rear wheel and front wheels of the truck slip. Hence $F_A = \mu_s N_A = 0.5N_A$ and $F_B = \mu_s N_B = 0.5N_B$. From FBD (b),

$$\left(+ \Sigma M_B = 0; \quad 1.25(10^3)(9.81)(1) + T(0.6) - N_A(2.5) = 0 \quad [3] \right.$$

$$\left(+ \Sigma M_A = 0; \quad N_B(2.5) + T(0.6) - 1.25(10^3)(9.81)(1.5) = 0 \quad [4] \right.$$

$$\left. \begin{aligned} \rightarrow \Sigma F_x = 0; \quad 0.5N_A + 0.5N_B - T = 0 \end{aligned} \quad [5] \right.$$

Solving Eqs. [3], [4] and [5] yields

$$N_A = 6376.5 \text{ N} \quad N_B = 5886.0 \text{ N} \quad T = 6131.25 \text{ N}$$

Since the crate moves, $F_C = \mu_c N_C = 0.4N_C$. From FBD (c),

$$+ \uparrow \Sigma F_y = 0; \quad N_C - W = 0 \quad N_C = W$$

$$\rightarrow \Sigma F_x = 0; \quad 6131.25 - 0.4W = 0$$

$$W = 15328.125 \text{ N} = 15.3 \text{ kN} \quad \text{Ans}$$

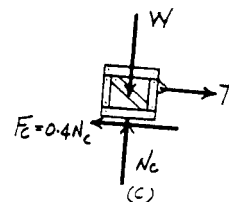
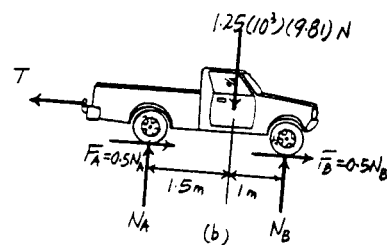
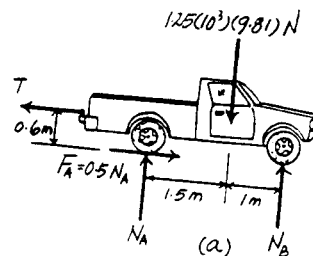

*8-136. Solve Prob. 8-135 if the truck and crate are traveling up a 10° incline.

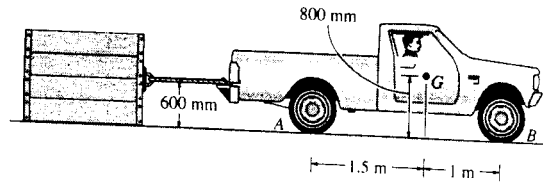

a) The truck with rear wheel drive.

Equations of Equilibrium and Friction: It is required that the rear wheel of the truck slip hence $F_A = \mu_s N_A = 0.5N_A$. From FBD (a),

$$\begin{aligned} (+\Sigma M_B = 0; & \quad 1.25(10^3)(9.81)\cos 10^\circ(1) \\ & \quad + 1.25(10^3)(9.81)\sin 10^\circ(0.8) \\ & \quad + T(0.6) - N_A(2.5) = 0 \end{aligned} \quad [1]$$

$$+\Sigma F_x = 0; \quad 0.5N_A - 1.25(10^3)(9.81)\sin 10^\circ - T = 0 \quad [2]$$

Solving Eqs. [1] and [2] yields

$$N_A = 5682.76 \text{ N} \quad T = 712.02 \text{ N}$$

Since the crate moves, $F_C = \mu_k N_C = 0.4N_C$. From FBD (c),

$$+\Sigma F_y = 0; \quad N_C - W\cos 10^\circ = 0 \quad N_C = 0.9848W$$

$$\begin{aligned} \rightarrow \Sigma F_x = 0; & \quad 712.02 - W\sin 10^\circ - 0.4(0.9848W) = 0 \\ & \quad W = 1254.50 \text{ N} = 1.25 \text{ kN} \end{aligned} \quad \text{Ans}$$

b) The truck with four wheel drive.

Equations of Equilibrium and Friction: It is required that the rear wheels of the truck slip hence $F_A = \mu_s N_A = 0.5N_A$. From FBD (a),

$$\begin{aligned} (+\Sigma M_B = 0; & \quad 1.25(10^3)(9.81)\cos 10^\circ(1) \\ & \quad + 1.25(10^3)(9.81)\sin 10^\circ(0.8) \\ & \quad + T(0.6) - N_A(2.5) = 0 \end{aligned} \quad [3]$$

$$\begin{aligned} (+\Sigma M_A = 0; & \quad -1.25(10^3)(9.81)\cos 10^\circ(1.5) \\ & \quad + 1.25(10^3)(9.81)\sin 10^\circ(0.8) \\ & \quad + T(0.6) + N_B(2.5) = 0 \end{aligned} \quad [4]$$

$$+\Sigma F_x = 0; \quad 0.5N_A + 0.5N_B - 1.25(10^3)(9.81)\sin 10^\circ - T = 0 \quad [5]$$

Solving Eqs. [3], [4] and [5] yields

$$N_A = 6449.98 \text{ N} \quad N_B = 5626.23 \text{ N} \quad T = 3908.74 \text{ N}$$

Since the crate moves, $F_C = \mu_k N_C = 0.4N_C$. From FBD (c),

$$+\Sigma F_y = 0; \quad N_C - W\cos 10^\circ = 0 \quad N_C = 0.9848W$$

$$\begin{aligned} \rightarrow \Sigma F_x = 0; & \quad 3908.74 - W\sin 10^\circ - 0.4(0.9848W) = 0 \\ & \quad W = 6886.79 \text{ N} = 6.89 \text{ kN} \end{aligned} \quad \text{Ans}$$

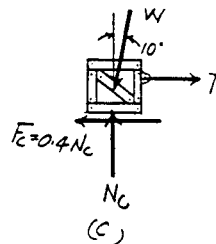
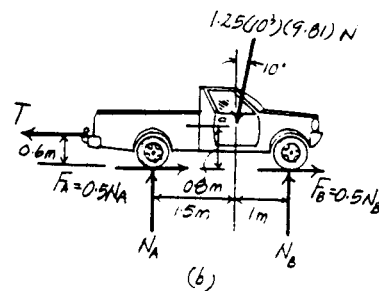
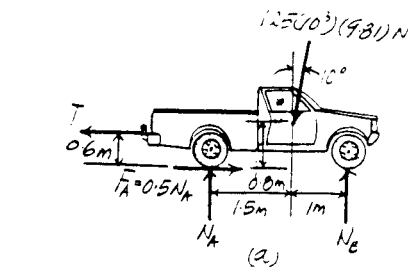

8-137. The cam or short link is pinned at A and is used to hold mops or brooms against a wall. If the coefficient of static friction between the broomstick and the cam is $\mu_s = 0.2$, determine if it is possible to support the broom having a weight W . The surface at B is smooth. Neglect the weight of the cam.

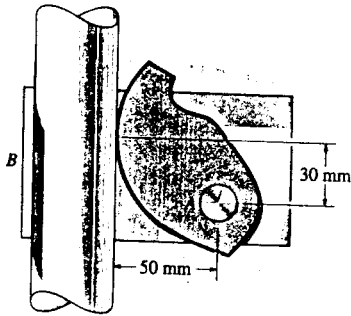

The cam is a two-force member.

Require

$$\frac{F}{3} = \frac{N}{5}$$

$$F = 0.6N$$

However $F_{max} = \mu_s N = 0.2N$

Therefore, the cam cannot support the broom.

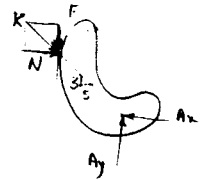

Ans

8-138. The carton clamp on the forklift has a coefficient of static friction of $\mu_s = 0.5$ with any cardboard carton, whereas a cardboard carton has a coefficient of static friction of $\mu'_s = 0.4$ with any other cardboard carton. Compute the smallest horizontal force P the clamp must exert on the sides of a carton so that two cartons A and B each weighing 30 lb can be lifted. What smallest clamping force P' is required to lift three 30-lb cartons? The third carton C is placed between A and B .

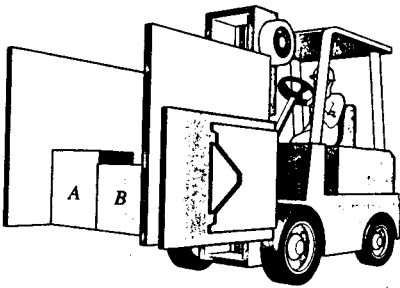

If two cartons against the clamp,

$$+\uparrow \Sigma F_y = 0; \quad 2F = 60$$

$$2(0.5N) = 60$$

$$N = 60 \text{ lb}$$

If the cartons slide against each other,

$$+\uparrow \Sigma F_y = 0; \quad F + F_c = 30$$

$$0.5N + 0.4N = 30$$

$$N = 33.33 \text{ lb}$$

Thus,

$$P = 60 \text{ lb for two cartons.}$$

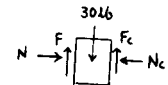
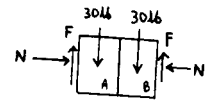

Ans

For three cartons:

If two cartons slide against each other,

$$+\uparrow \Sigma F_y = 0; \quad 2F_c = 30$$

$$2(0.4N_c) = 30$$

$$N_c = 37.5 \text{ lb}$$

If the cartons slide against the clamp,

$$+\uparrow \Sigma F_y = 0; \quad 2F = 90 \text{ lb}$$

$$2(0.5N) = 90$$

$$N = 90 \text{ lb}$$

$P = 90 \text{ lb for three cartons.}$

Ans

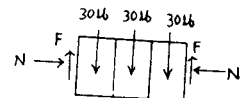
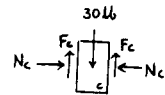

8-139. The tractor pulls on the fixed tree stump. Determine the torque that must be applied by the engine to the rear wheels to cause them to slip. The front wheels are free to roll. The tractor weighs 3500 lb and has a center of gravity at G . The coefficient of static friction between the rear wheels and the ground is $\mu_s = 0.5$.

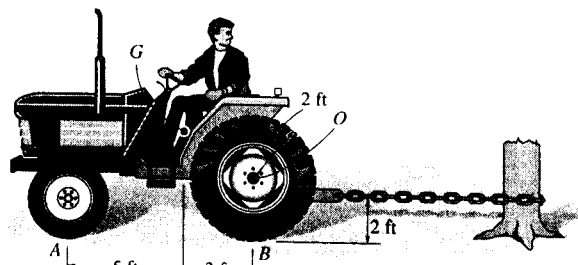

Equations of Equilibrium and Friction: Assume that the rear wheels B slip. Hence $F_B = \mu_s N_B = 0.5N_B$.

$$\curvearrowleft + \Sigma M_A = 0 \quad N_B(8) - T(2) - 3500(5) = 0 \quad [1]$$

$$+ \uparrow \Sigma F_y = 0; \quad N_B + N_A - 3500 = 0 \quad [2]$$

$$\rightarrow \Sigma F_x = 0; \quad T - 0.5N_B = 0 \quad [3]$$

Solving Eqs. [1], [2] and [3] yields

$$N_A = 1000 \text{ lb} \quad N_B = 2500 \text{ lb} \quad T = 1250 \text{ lb}$$

Since $N_A > 0$, the front wheels do not lift up. Therefore the rear wheels slip as assumed. Thus, $F_B = 0.5(2500) = 1250 \text{ lb}$. From FBD (b),

$$\begin{aligned} \curvearrowleft + \Sigma M_O = 0, \quad M - 1250(2) = 0 \\ M = 2500 \text{ lb} \cdot \text{ft} = 2.50 \text{ kip} \cdot \text{ft} \quad \text{Ans} \end{aligned}$$

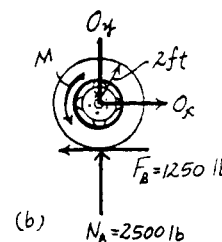
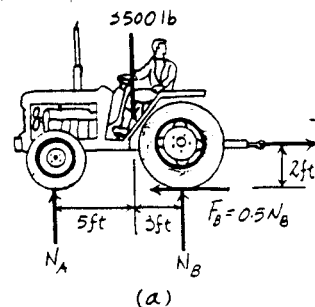

*8-140. The tractor pulls on the fixed tree stump. If the coefficient of static friction between the rear wheels and the ground is $\mu_s = 0.6$, determine if the rear wheels slip or the front wheels lift off the ground as the engine provides torque to the rear wheels. What is the torque needed to cause the motion? The front wheels are free to roll. The tractor weighs 2500 lb and has a center of gravity at G .

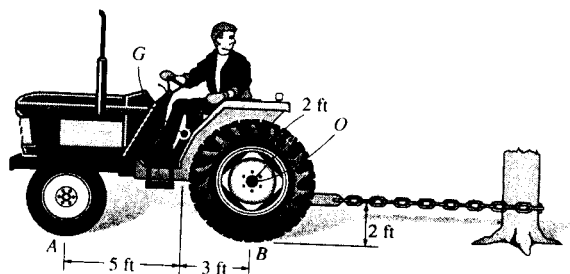

Equations of Equilibrium and Friction: Assume that the rear wheels B slip. Hence $F_B = \mu_s N_B = 0.6N_B$.

$$\curvearrowleft + \Sigma M_A = 0 \quad N_B(8) - T(2) - 2500(5) = 0 \quad [1]$$

$$+ \uparrow \Sigma F_y = 0; \quad N_B + N_A - 2500 = 0 \quad [2]$$

$$\rightarrow \Sigma F_x = 0; \quad T - 0.6N_B = 0 \quad [3]$$

Solving Eqs. [1], [2] and [3] yields

$$N_A = 661.76 \text{ lb} \quad N_B = 1838.24 \text{ lb} \quad T = 1102.94 \text{ lb}$$

Since $N_A > 0$, the front wheels do not lift off the ground. Therefore the rear wheels slip as assumed. Thus, $F_B = 0.6(1838.24) = 1102.94 \text{ lb}$. From FBD (b),

$$\begin{aligned} + \Sigma M_O = 0, \quad M - 1102.94(2) = 0 \\ M = 2205.88 \text{ lb} \cdot \text{ft} = 2.21 \text{ kip} \cdot \text{ft} \quad \text{Ans} \end{aligned}$$

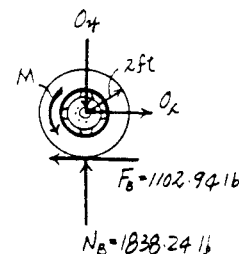
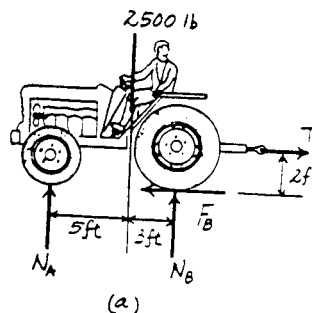

9-1. Determine the distance \bar{x} to the center of mass of the homogeneous rod bent into the shape shown. If the rod has a mass per unit length of 0.5 kg/m, determine the reactions at the fixed support O .

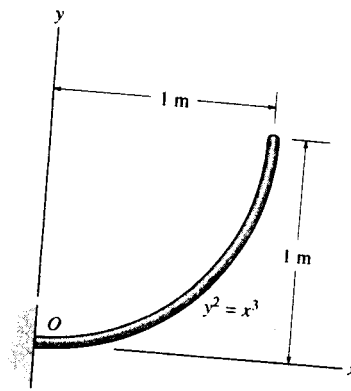

Length and Moment Arm: The length of the differential element is $dL = \sqrt{dx^2 + dy^2} = \sqrt{1 + \left(\frac{dy}{dx}\right)^2} dx$ and its centroid is $\bar{x} = x$. Here, $\frac{dy}{dx} = \frac{3}{2}x^{\frac{1}{2}}$. Performing the integration, we have

$$L = \int dL = \int_0^{1\text{m}} \left(1 + \frac{9}{4}x\right)^{\frac{1}{2}} dx = \frac{8}{27} \left(1 + \frac{9}{4}x\right)^{\frac{3}{2}} \Big|_0^{1\text{m}} = 1.4397 \text{ m}$$

$$\begin{aligned} \int_L \bar{x} dL &= \int_0^{1\text{m}} x \sqrt{1 + \frac{9}{4}x} dx \\ &= \left[\frac{8}{27} x \left(1 + \frac{9}{4}x\right)^{\frac{3}{2}} - \frac{64}{1215} \left(1 + \frac{9}{4}x\right)^{\frac{5}{2}} \right] \Big|_0^{1\text{m}} \\ &= 0.7857 \end{aligned}$$

Centroid: Applying Eq. 9-7, we have

$$\bar{x} = \frac{\int_L \bar{x} dL}{\int_L dL} = \frac{0.7857}{1.4397} = 0.5457 \text{ m} = 0.546 \text{ m} \quad \text{Ans}$$

Equations of Equilibrium:

$$\rightarrow \Sigma F_x = 0; \quad O_x = 0 \quad \text{Ans}$$

$$\begin{aligned} + \uparrow \Sigma F_y = 0; \quad O_y - 0.5(9.81)(1.4397) &= 0 \\ O_y &= 7.06 \text{ N} \quad \text{Ans} \end{aligned}$$

$$\begin{aligned} \curvearrowright + \Sigma M_O = 0; \quad M_O - 0.5(9.81)(1.4397)(0.5457) &= 0 \\ M_O &= 3.85 \text{ N} \cdot \text{m} \quad \text{Ans} \end{aligned}$$

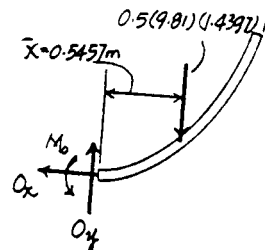
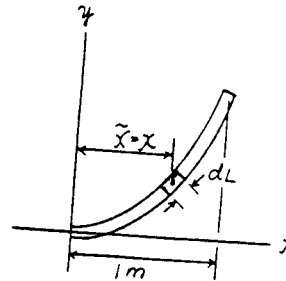

9-2. Determine the location (\bar{x}, \bar{y}) of the centroid of the wire.

Length and Moment Arm: The length of the differential element is dL

$$= \sqrt{dx^2 + dy^2} = \left(\sqrt{1 + \left(\frac{dy}{dx}\right)^2} \right) dx \text{ and its centroid is } \bar{y} = y = x^2. \text{ Here,}$$

$$\frac{dy}{dx} = 2x.$$

Centroid: Due to symmetry

$$\bar{x} = 0$$

Ans

Applying Eq. 9-7 and performing the integration, we have

$$\begin{aligned} \bar{y} &= \frac{\int_L \bar{y} dL}{\int_L dL} = \frac{\int_{-2\text{ft}}^{2\text{ft}} x^2 \sqrt{1+4x^2} dx}{\int_{-2\text{ft}}^{2\text{ft}} \sqrt{1+4x^2} dx} \\ &= \frac{16.9423}{9.2936} = 1.82 \text{ ft} \end{aligned}$$

Ans

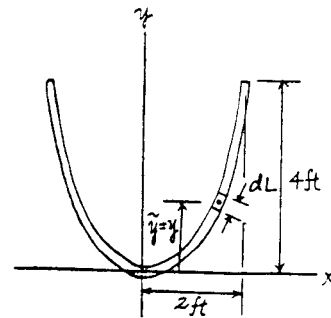
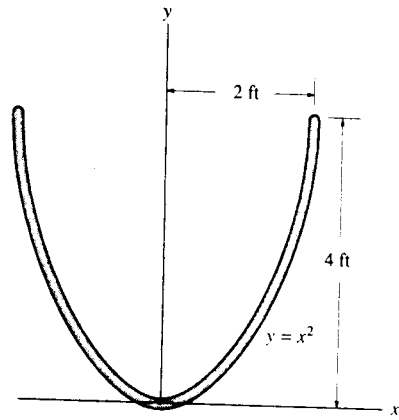

9-3. Locate the center of mass of the homogeneous rod bent into the shape of a circular arc.

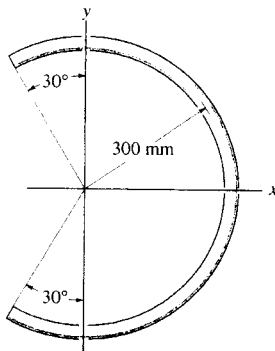

$$dL = 300 d\theta$$

$$\bar{x} = 300 \cos \theta$$

$$\bar{y} = 300 \sin \theta$$

$$\bar{x} = \frac{\int \bar{x} dL}{\int dL} = \frac{\int_{-\frac{\pi}{6}}^{\frac{\pi}{6}} 300 \cos \theta (300 d\theta)}{\int_{-\frac{\pi}{6}}^{\frac{\pi}{6}} 300 d\theta}$$

$$= \frac{(300)^2 [\sin \theta]_{-\frac{\pi}{6}}^{\frac{\pi}{6}}}{300(\frac{\pi}{3})}$$

$$= 124 \text{ mm} \quad \text{Ans}$$

$$\bar{y} = 0 \quad \text{Ans (By symmetry)}$$

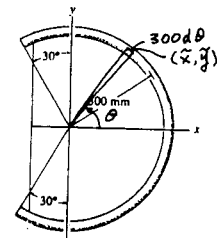

*9-4. Locate the center of gravity \bar{x} of the homogeneous rod bent in the form of a semicircular arc. The rod has a weight per unit length of 0.5 lb/ft. Also, determine the horizontal reaction at the smooth support B and the x and y components of reaction at the pin A .

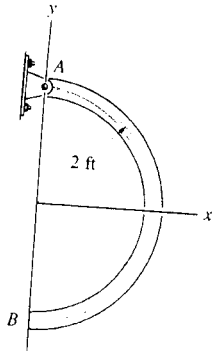

$$\bar{x} = 2 \cos \theta$$

$$\bar{y} = 2 \sin \theta$$

$$dL = 2 d\theta$$

$$\bar{x} = \frac{\int \bar{x} dL}{\int dL} = \frac{\int_{-\pi/2}^{\pi/2} 2 \cos \theta \cdot 2 d\theta}{\int_{-\pi/2}^{\pi/2} 2 d\theta}$$

$$= \frac{4[\sin \theta]_{-\pi/2}^{\pi/2}}{[2\theta]_{-\pi/2}^{\pi/2}}$$

$$= \frac{4}{\pi} \quad \text{Ans}$$

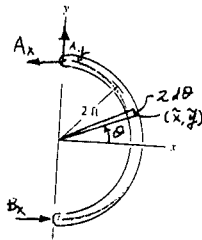

$$\text{Arc length} = \pi r = 2\pi$$

$$W = 2\pi(0.5) \text{ lb}$$

$$\sum M_A = 0; \quad -2\pi(0.5)\left(\frac{4}{\pi}\right) + B_x(4) = 0$$

$$B_x = 1 \text{ lb} \quad \text{Ans}$$

$$\sum F_x = 0; \quad A_x = 1 \text{ lb} \quad \text{Ans}$$

$$\sum F_y = 0; \quad A_y = 3.14 \text{ lb} \quad \text{Ans}$$

9-5. Determine the distance \bar{x} to the center of gravity of the homogeneous rod bent into the parabolic shape. If the rod has a weight per unit length of 0.5 lb/ft, determine the reactions at the fixed support O .

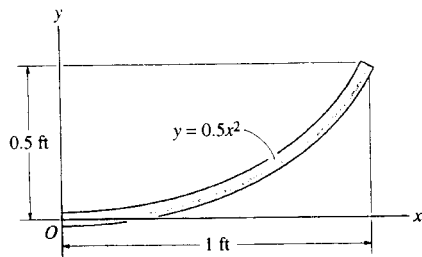

$$dL = \sqrt{dx^2 + dy^2}$$

$$dy = x dx$$

$$\bar{x} = \frac{\int \bar{x} dL}{\int dL} = \frac{\int_0^1 x \sqrt{dx^2 + x^2 dx^2}}{\int_0^1 \sqrt{dx^2 + x^2 dx^2}}$$

$$\text{Let } x = \tan \theta$$

$$dx = \sec^2 \theta d\theta$$

$$\begin{aligned} \bar{x} &= \frac{\int_0^{\frac{\pi}{2}} \tan \theta \sqrt{1 + \tan^2 \theta} \sec^2 \theta d\theta}{\int_0^{\frac{\pi}{2}} \sqrt{1 + \tan^2 \theta} \sec^2 \theta d\theta} \\ &= \frac{\left[\frac{\sec^2 \theta}{3} \right]_0^{\frac{\pi}{2}}}{\left[\frac{\sec \theta \tan \theta}{2} + \frac{1}{2} (\ln |\sec \theta + \tan \theta|) \right]_0^{\frac{\pi}{2}}} \end{aligned}$$

$$\bar{x} = 0.531 \text{ ft} \quad \text{Ans}$$

Also,

$$dL = \sqrt{dx^2 + dy^2}$$

$$L = \int \sqrt{1 + \left(\frac{dy}{dx}\right)^2} dx$$

$$= \int_0^1 \sqrt{1 + x^2} dx$$

$$= 1.148 \text{ ft}$$

$$\int \bar{x} dL = \int_0^1 x \sqrt{1 + x^2} dx$$

$$= 0.6095$$

$$\bar{x} = \frac{0.6095}{1.148} = 0.531 \text{ ft} \quad \text{Ans}$$

$$\rightarrow \Sigma F_x = 0; \quad O_x = 0 \quad \text{Ans}$$

$$\begin{aligned} + \uparrow \Sigma F_y = 0; \quad O_y - 0.5(1.148) &= 0 \\ O_y &= 0.574 \text{ lb} \quad \text{Ans} \end{aligned}$$

$$\begin{aligned} (+ \Sigma M_O = 0; \quad M_O - 0.5(1.148)(0.531) &= 0 \\ M_O &= 0.305 \text{ lb-ft} \quad \text{Ans} \end{aligned}$$

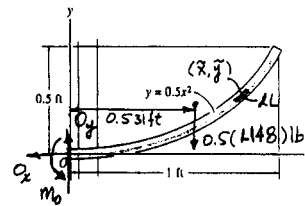

9-6. Determine the distance \bar{y} to the center of gravity of the homogeneous rod bent into the parabolic shape.

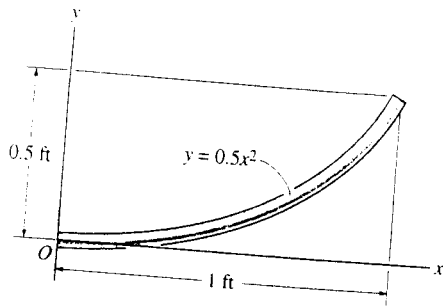

$$dL = \sqrt{dx^2 + dy^2}$$

$$L = \int \sqrt{1 + \left(\frac{dy}{dx}\right)^2} dx$$

$$= \int_0^1 \sqrt{1 + x^2} dx$$

$$= 1.148 \text{ ft}$$

$$\int \bar{y} dL = \int_0^1 0.5x^2 \sqrt{1 + x^2} dx$$

$$= 0.2101 \text{ ft}$$

$$\bar{y} = \frac{0.2101}{1.148} = 0.183 \text{ ft} \quad \text{Ans}$$

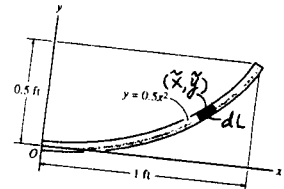

9-7. Locate the centroid of the parabolic area.

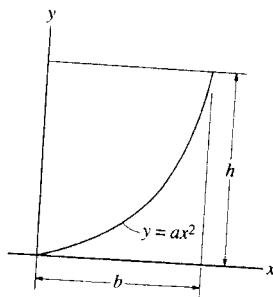

$$dA = x dy$$

$$\bar{x} = \frac{x}{2}$$

$$\bar{y} = y$$

$$\bar{x} = \frac{\int_A \bar{x} dA}{\int_A dA} = \frac{\int_0^h \frac{x}{2} \frac{2}{a} dy}{\int_0^h \frac{2}{a} dy} = \frac{\left[\frac{x^2}{4}\right]_0^h}{\left[\frac{2y}{a}\right]_0^h} = \frac{3}{8} \sqrt{\frac{h}{a}} = \frac{3}{8} b$$

$$\bar{y} = \frac{\int_A \bar{y} dA}{\int_A dA} = \frac{\int_0^h \frac{2y^2}{3a} dy}{\int_0^h \frac{2}{a} dy} = \frac{\left[\frac{2y^3}{9a}\right]_0^h}{\left[\frac{2y}{a}\right]_0^h} = \frac{3}{5} h$$

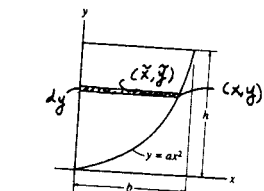

Ans

Ans

*9-8. Locate the centroid (\bar{x}, \bar{y}) of the shaded area.

Area and Moment Arm: The area of the differential element is $dA = y dx$
 $= \left(1 - \frac{1}{4}x^2\right) dx$ and its centroid is $\bar{y} = \frac{y}{2} = \frac{1}{2} \left(1 - \frac{1}{4}x^2\right)$.

Centroid: Due to symmetry

$$\bar{x} = 0$$

Ans

Applying Eq. 9-6 and performing the integration, we have

$$\bar{y} = \frac{\int_A \bar{y} dA}{\int_A dA} = \frac{\int_{-2m}^{2m} \frac{1}{2} \left(1 - \frac{1}{4}x^2\right) \left(1 - \frac{1}{4}x^2\right) dx}{\int_{-2m}^{2m} \left(1 - \frac{1}{4}x^2\right) dx}$$

$$= \frac{\left(\frac{x}{2} - \frac{x^3}{12} + \frac{x^5}{160}\right) \Big|_{-2m}^{2m}}{\left(x - \frac{x^3}{12}\right) \Big|_{-2m}^{2m}} = \frac{2}{5} \text{ m}$$

Ans

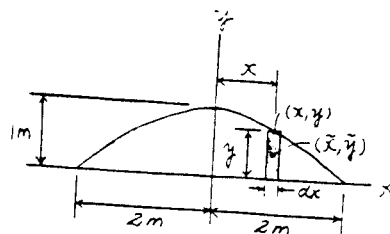
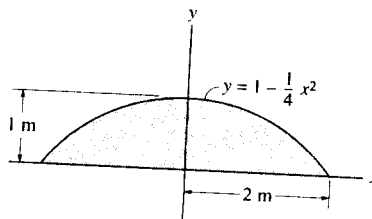

9-9. Locate the centroid of the shaded area.

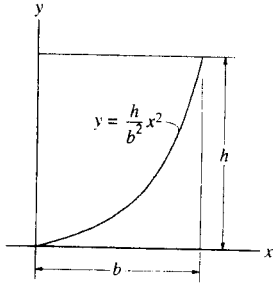

$$dA = y \, dx$$

$$\bar{x} = x$$

$$\bar{y} = \frac{y}{2}$$

$$\bar{x} = \frac{\int_A \bar{x} \, dA}{\int_A dA} = \frac{\int_0^b \frac{h}{b^2} x^3 \, dx}{\int_0^b \frac{h}{b^2} x^2 \, dx} = \frac{[\frac{h}{4b^2} x^4]_0^b}{[\frac{h}{3b^2} x^3]_0^b} = \frac{3}{4} b$$

$$\bar{y} = \frac{\int_A \bar{y} \, dA}{\int_A dA} = \frac{\int_0^b \frac{h}{2b^2} x^4 \, dx}{\int_0^b \frac{h}{b^2} x^2 \, dx} = \frac{[\frac{h^2}{10b^2} x^5]_0^b}{[\frac{h}{3b^2} x^3]_0^b} = \frac{3}{10} h$$

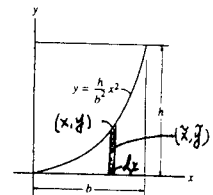

Ans

Ans

9-10. Locate the centroid \bar{x} of the shaded area.

Area and Moment Arm: The area of the differential element is $dA = y \, dx = 2k(x - \frac{x^2}{2a}) \, dx$ and its centroid is $\bar{x} = x$.

Centroid: Applying Eq. 9-6 and performing the integration, we have

$$\begin{aligned} \bar{x} &= \frac{\int_A \bar{x} \, dA}{\int_A dA} = \frac{\int_0^a x \left[2k \left(x - \frac{x^2}{2a} \right) dx \right]}{\int_0^a 2k \left(x - \frac{x^2}{2a} \right) dx} \\ &= \frac{2k \left(\frac{x^3}{3} - \frac{x^4}{8a} \right) \Big|_0^a}{2k \left(\frac{x^2}{2} - \frac{x^3}{6a} \right) \Big|_0^a} = \frac{5a}{8} \end{aligned}$$

Ans

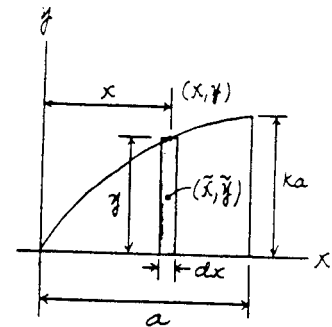
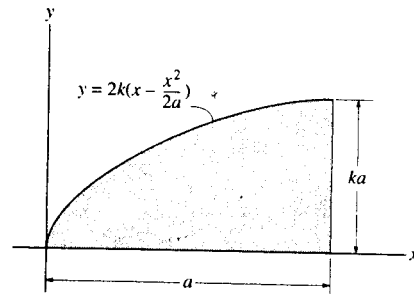

9-11. Locate the centroid \bar{x} of the shaded area.

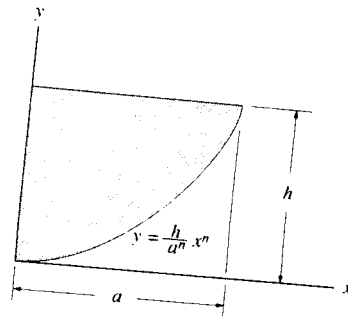

Area and Moment Arm : The area of the differential element is $dA = (h - y) dx$
 $= h \left(1 - \frac{x^n}{a^n} \right) dx$ and its centroid is $\bar{x} = x$.

Centroid : Applying Eq. 9-6 and performing the integration, we have

$$\begin{aligned} \bar{x} &= \frac{\int_A \bar{x} dA}{\int_A dA} = \frac{\int_0^a x \left[h \left(1 - \frac{x^n}{a^n} \right) dx \right]}{\int_0^a h \left(1 - \frac{x^n}{a^n} \right) dx} \\ &= \frac{h \left(\frac{x^2}{2} - \frac{x^{n+2}}{(n+2)a^n} \right) \Big|_0^a}{h \left(x - \frac{x^{n+1}}{(n+1)a^n} \right) \Big|_0^a} \\ &= \frac{n+1}{2(n+2)} a \end{aligned}$$

Ans

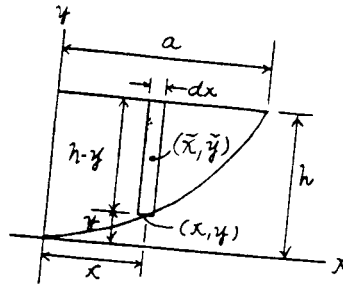

*9-12. Locate the centroid of the shaded area.

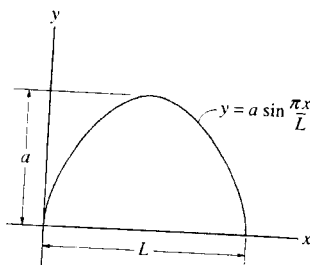

$$dA = y dx$$

$$\bar{x} = x$$

$$\bar{y} = \frac{y}{2}$$

$$\int_A dA = \int_0^L a \sin \frac{\pi x}{L} dx = \left[-\frac{a \cos \frac{\pi x}{L}}{\frac{\pi}{L}} \right]_0^L = \frac{2aL}{\pi}$$

$$\int_A \bar{y} dA = \frac{1}{2} \int_0^L a^2 \sin^2 \frac{\pi x}{L} dx = \frac{a^2}{2} \left[-\frac{\sin \frac{2\pi x}{L}}{\frac{2\pi}{L}} + \frac{x}{2} \right]_0^L = \frac{a^2 L}{4}$$

$$\bar{y} = \frac{\int_A \bar{y} dA}{\int_A dA} = \frac{\frac{a^2 L}{4}}{\frac{2aL}{\pi}} = \frac{a\pi}{8} \quad \text{Ans}$$

$$\bar{x} = \frac{L}{2}$$

Ans (By symmetry)

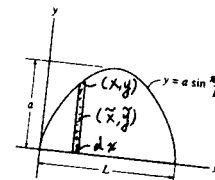

9-13. The plate has a thickness of 0.25 ft and a specific weight of $\gamma = 180 \text{ lb/ft}^3$. Determine the location of its center of gravity. Also, find the tension in each of the cords used to support it.

Area and Moment Arm: Here, $y = x - 8x^{\frac{1}{2}} + 16$. The area of the differential element is $dA = y dx = (x - 8x^{\frac{1}{2}} + 16) dx$ and its centroid is $\bar{x} = x$ and $\bar{y} = \frac{1}{2}(x - 8x^{\frac{1}{2}} + 16)$. Evaluating the integrals, we have

$$A = \int_A dA = \int_0^{16} (x - 8x^{\frac{1}{2}} + 16) dx$$

$$= \left(\frac{1}{2}x^2 - \frac{16}{3}x^{\frac{3}{2}} + 16x \right) \Big|_0^{16} = 42.67 \text{ ft}^2$$

$$\int_A \bar{x} dA = \int_0^{16} x(x - 8x^{\frac{1}{2}} + 16) dx$$

$$= \left(\frac{1}{3}x^3 - \frac{16}{5}x^{\frac{5}{2}} + 8x^2 \right) \Big|_0^{16} = 136.53 \text{ ft}^3$$

$$\int_A \bar{y} dA = \int_0^{16} \frac{1}{2}(x - 8x^{\frac{1}{2}} + 16)(x - 8x^{\frac{1}{2}} + 16) dx$$

$$= \frac{1}{2} \left(\frac{1}{3}x^3 - \frac{32}{5}x^{\frac{5}{2}} + 48x^2 - \frac{512}{3}x^{\frac{3}{2}} + 256x \right) \Big|_0^{16} = 136.53 \text{ ft}^3$$

Centroid: Applying Eq. 9-6, we have

$$\bar{x} = \frac{\int_A \bar{x} dA}{\int_A dA} = \frac{136.53}{42.67} = 3.20 \text{ ft} \quad \text{Ans}$$

$$\bar{y} = \frac{\int_A \bar{y} dA}{\int_A dA} = \frac{136.53}{42.67} = 3.20 \text{ ft} \quad \text{Ans}$$

Equations of Equilibrium: The weight of the plate is $W = 42.67(0.25)(180) = 1920 \text{ lb}$.

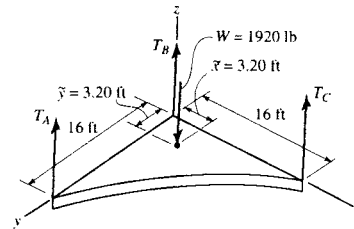
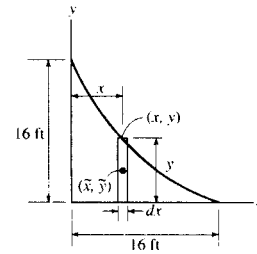
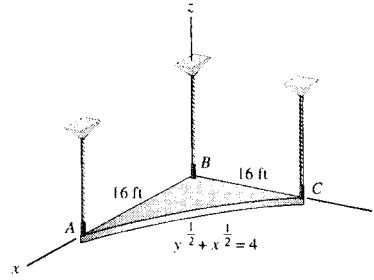

$$\Sigma M_x = 0; \quad 1920(3.20) - T_A(16) = 0 \quad T_A = 384 \text{ lb} \quad \text{Ans}$$

$$\Sigma M_y = 0; \quad T_C(16) - 1920(3.20) = 0 \quad T_C = 384 \text{ lb} \quad \text{Ans}$$

$$\Sigma F_z = 0; \quad T_B + 384 + 384 - 1920 = 0$$

$$T_B = 1152 \text{ lb} = 1.15 \text{ kip} \quad \text{Ans}$$

9-14. Locate the centroid \bar{y} of the shaded area.

$$dA = y dx$$

$$\bar{x} = x$$

$$\bar{y} = \frac{y}{2}$$

$$\bar{x} = \frac{\int_A \bar{x} dA}{\int_A dA} = \frac{\int_0^a \frac{h}{a^n} x^{n+1} dx}{\int_0^a \frac{h}{a^n} x^n dx} = \frac{\frac{h(a^{n+2})}{a^n(n+2)}}{\frac{h(a^{n+1})}{a^n(n+1)}}$$

$$= \frac{(n+1)}{2(n+2)} a \quad \text{Ans}$$

$$\bar{y} = \frac{\int_A \bar{y} dA}{\int_A dA} = \frac{\frac{1}{2} \int_0^a \frac{h^2}{a^{2n}} x^{2n} dx}{\int_0^a \frac{h}{a^n} x^n dx} = \frac{\frac{h^2(a^{2n+1})}{2a^{2n}(2n+1)}}{\frac{h(a^{n+1})}{a^n(n+1)}}$$

$$= \frac{n+1}{2(2n+1)} h \quad \text{Ans}$$

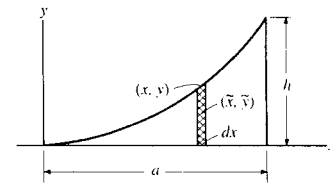
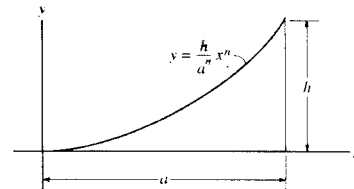

9-15. Locate the centroid of the shaded area.

$$dA = y dx$$

$$\bar{x} = x$$

$$\bar{y} = \frac{y}{2}$$

$$\bar{x} = \frac{\int_A \bar{x} dA}{\int_A dA} = \frac{\int_0^a \left(hx - \frac{h}{a^n} x^{n+1} \right) dx}{\int_0^a \left(h - \frac{h}{a^n} x^n \right) dx}$$

$$= \frac{\left[\frac{h}{2} x^2 - \frac{h(x^{n+2})}{a^n(n+2)} \right]_0^a}{\left[hx - \frac{h(x^{n+1})}{a^n(n+1)} \right]_0^a}$$

$$\bar{x} = \frac{\left(\frac{h}{2} - \frac{h}{n+2} \right) a^2}{\left(h - \frac{h}{n+1} \right) a} = \frac{n-1}{2(n+2)} a$$

Ans

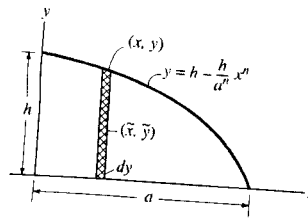
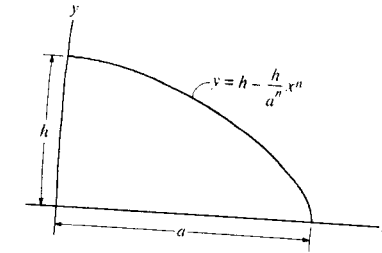

$$\bar{y} = \frac{\int_A \bar{y} dA}{\int_A dA} = \frac{\frac{1}{2} \int_0^a \left(h^2 - 2\frac{h^2}{a^n} x^n - \frac{h^2}{a^{2n}} x^{2n} \right) dx}{\int_0^a \left(h - \frac{h}{a^n} x^n \right) dx}$$

$$= \frac{\frac{1}{2} \left[h^2 x - \frac{2h^2(x^{n+1})}{a^n(n+1)} + \frac{h^2(x^{2n+1})}{a^{2n}(2n+1)} \right]_0^a}{\left[hx - \frac{h(x^{n+1})}{a^n(n+1)} \right]_0^a}$$

$$\bar{y} = \frac{2n^2}{2(n+1)(2n+1)} \frac{h}{n+1} = \frac{nh}{2n^2}$$

Ans

*9-16. Locate the centroid of the shaded area bounded by the parabola and the line $y = a$

$$dA = x dy$$

$$\bar{x} = \frac{x}{2}$$

$$\bar{y} = y$$

$$\int_A dA = \int_0^a x dy = \int_0^a \sqrt{\frac{2}{3} a^{3/2} y} dy = \sqrt{\frac{2}{3} a^{3/2}} \left(\frac{2}{3} a^{3/2} y^{3/2} \right) = \frac{2}{3} a^2$$

$$\int_A \bar{x} dA = \int_0^a \frac{x^2}{2} dy = \frac{1}{4} a^3$$

$$\bar{x} = \frac{\int_A \bar{x} dA}{\int_A dA} = \frac{\frac{1}{4} a^3}{\frac{2}{3} a^2} = \frac{3}{8} a$$

Ans

$$\int_A \bar{y} dA = \int_0^a xy dy = \int_0^a \sqrt{\frac{2}{3} a^{3/2} y^3} dy = \sqrt{\frac{2}{3} a^{3/2}} \left(\frac{2}{5} a^{3/2} y^{5/2} \right) = \frac{2}{5} a^3$$

$$\bar{y} = \frac{\int_A \bar{y} dA}{\int_A dA} = \frac{\frac{2}{5} a^3}{\frac{2}{3} a^2} = \frac{3}{5} a$$

Ans

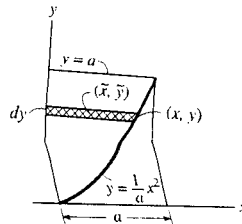
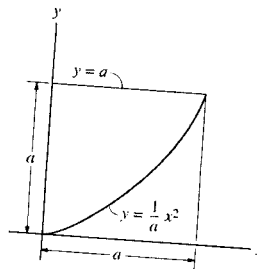

9-17. Locate the centroid of the quarter elliptical area.

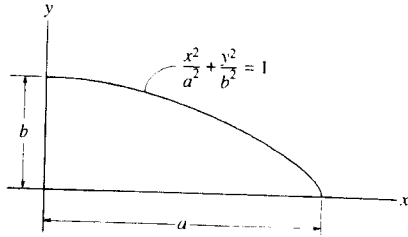

$$dA = y dx$$

$$\bar{x} = x$$

$$\bar{y} = \frac{y}{2}$$

$$\int_A dA = \int_0^a \sqrt{b^2 - \frac{b^2}{a^2}x^2} dx = \frac{b}{2a} \left[x\sqrt{a^2 - x^2} + a^2 \sin^{-1} \frac{x}{a} \right]_0^a = \frac{\pi}{4} ab$$

$$\int_A \bar{y} dA = \frac{1}{2} \int_0^a (b^2 - \frac{b^2}{a^2}x^2) dx = \frac{1}{2} \left[b^2x - \frac{b^2}{3a^2}x^3 \right]_0^a = \frac{1}{3} ab^2$$

$$\bar{y} = \frac{\int_A \bar{y} dA}{\int_A dA} = \frac{\frac{1}{3} ab^2}{\frac{\pi}{4} ab} = \frac{4b}{3\pi} \quad \text{Ans}$$

$$dA = x dy$$

$$\bar{x} = \frac{x}{2}$$

$$\int_A \bar{x} dA = \frac{1}{2} \int_0^b (a^2 - \frac{a^2}{b^2}y^2) dy = \frac{1}{2} \left[a^2y - \frac{a^2}{3b^2}y^3 \right]_0^b = \frac{1}{3} a^2b$$

$$\bar{x} = \frac{\int_A \bar{x} dA}{\int_A dA} = \frac{\frac{1}{3} a^2b}{\frac{\pi}{4} ab} = \frac{4a}{3\pi} \quad \text{Ans}$$

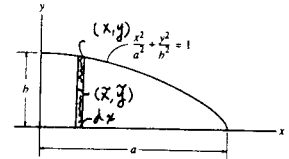

9-18. Locate the centroid (\bar{x} , \bar{y}) of the shaded area.

Area and Moment Arm: The area of the differential element is $dA = y dx$
 $= a \sin \frac{x}{a} dx$ and its centroid are $\bar{x} = x$ and $\bar{y} = \frac{y}{2} = \frac{a}{2} \sin \frac{x}{a}$.

Centroid: Applying Eq. 9-6 and performing the integration, we have

$$\begin{aligned} \bar{x} &= \frac{\int_A \bar{x} dA}{\int_A dA} = \frac{\int_0^{a\pi} x \left(a \sin \frac{x}{a} dx \right)}{\int_0^{a\pi} a \sin \frac{x}{a} dx} \\ &= \frac{\left[a^3 \sin \frac{x}{a} - x \left(a^2 \cos \frac{x}{a} \right) \right]_0^{a\pi}}{\left(-a^2 \cos \frac{x}{a} \right)_0^{a\pi}} \\ &= \frac{\pi}{2} a \quad \text{Ans} \end{aligned}$$

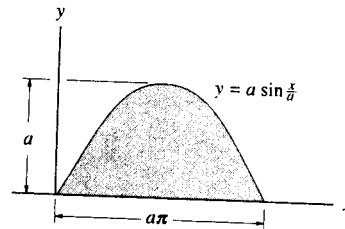

$$\begin{aligned} \bar{y} &= \frac{\int_A \bar{y} dA}{\int_A dA} = \frac{\int_0^{a\pi} \frac{a}{2} \sin \frac{x}{a} \left(a \sin \frac{x}{a} dx \right)}{\int_0^{a\pi} a \sin \frac{x}{a} dx} \\ &= \frac{\left[\frac{1}{4} a^2 \left(x - \frac{1}{2} a \sin \frac{2x}{a} \right) \right]_0^{a\pi}}{\left(-a^2 \cos \frac{x}{a} \right)_0^{a\pi}} = \frac{\pi}{8} a \quad \text{Ans} \end{aligned}$$

9-19. Locate the centroid of the shaded area.

$$dA = (4 - y)dx = \left(4 - \frac{1}{16}x^2\right) dx$$

$$\bar{x} = x$$

$$\bar{y} = \frac{4 + y}{2}$$

$$\bar{y} = \frac{\int_A \bar{y} dA}{\int_A dA} = \frac{\frac{1}{2} \int_0^8 \left(16 - \left(\frac{1}{16}x^2\right)^2\right) dx}{\int_0^8 \left(4 - \frac{1}{16}x^2\right) dx}$$

$$\bar{y} = 2.80 \text{ m}$$

Ans

$$\bar{x} = \frac{\int_A \bar{x} dA}{\int_A dA} = \frac{\int_0^8 x \left(4 - \frac{1}{16}x^2\right) dx}{\int_0^8 \left(4 - \frac{1}{16}x^2\right) dx}$$

$$\bar{x} = 3.00 \text{ m}$$

Ans

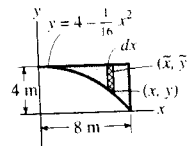
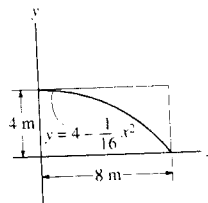

*9-20. Locate the centroid \bar{x} of the shaded area. Solve the problem by evaluating the integrals using Simpson's rule.

$$\int_A dA = \int_0^2 (2.786 - y) dx = \int_0^2 (2.786 - \sqrt{x^{1/2} + 2x^{5/3}}) dx = 2.177 \text{ ft}^2$$

$$\int_A \bar{x} dA = \int_0^2 x(2.786 - \sqrt{x^{1/2} + 2x^{5/3}}) dx = 1.412 \text{ ft}^3$$

$$\bar{x} = \frac{\int_A \bar{x} dA}{\int_A dA} = \frac{1.412}{2.177} = 0.649 \text{ ft}$$

Ans

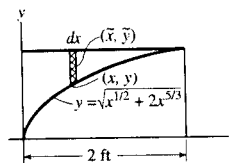
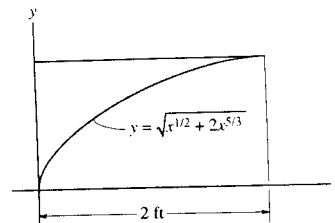

9-21. Locate the centroid \bar{y} of the shaded area. Solve the problem by evaluating the integrals using Simpson's rule.

$$\int_A dA = \int_0^2 (2.786 - y) dx = \int_0^2 (2.786 - \sqrt{x^{1/2} + 2x^{5/3}}) dx = 2.177 \text{ ft}^2$$

$$\int_A \bar{y} dA = \int_0^2 \left(\frac{2.786 + y}{2}\right) (2.786 - y) dx$$

$$= \int_0^2 \frac{1}{2} \{(2.786)^2 - y^2\} dx$$

$$= \frac{1}{2} \int_0^2 [7.764 - (x^{1/2} + 2x^{5/3})] dx = 4.440 \text{ ft}^3$$

$$\bar{y} = \frac{\int_A \bar{y} dA}{\int_A dA} = \frac{4.440}{2.177} = 2.04 \text{ ft}$$

Ans

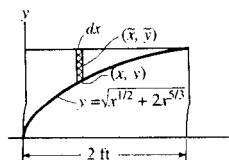
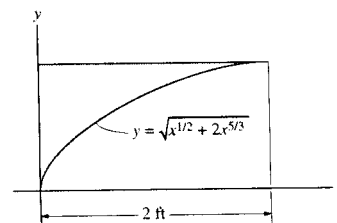

9-22. The steel plate is 0.3 m thick and has a density of 7850 kg/m³. Determine the location of its center of mass. Also compute the reactions at the pin and roller support.

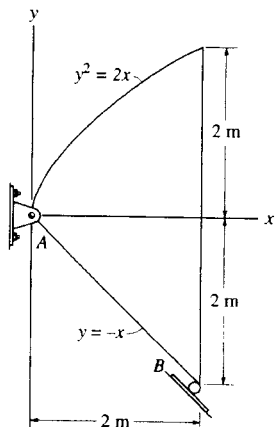

$$y_1 = -x_1$$

$$y_2^2 = 2x_2$$

$$dA = (y_2 - y_1) dx = (\sqrt{2x} + x) dx$$

$$\bar{x} = x$$

$$\bar{y} = \frac{y_2 + y_1}{2} = \frac{\sqrt{2x} - x}{2}$$

$$\bar{x} = \frac{\int_A \bar{x} dA}{\int_A dA} = \frac{\int_0^2 x(\sqrt{2x} + x) dx}{\int_0^2 (\sqrt{2x} + x) dx} = \frac{\left[\frac{2\sqrt{2}}{5}x^{5/2} + \frac{1}{2}x^3\right]_0^2}{\left[\frac{2\sqrt{2}}{3}x^{3/2} + \frac{1}{2}x^2\right]_0^2} = 1.2571 = 1.26 \text{ m} \quad \text{Ans}$$

$$\bar{y} = \frac{\int_A \bar{y} dA}{\int_A dA} = \frac{\int_0^2 \frac{\sqrt{2x} - x}{2} (\sqrt{2x} + x) dx}{\int_0^2 (\sqrt{2x} + x) dx} = \frac{\left[\frac{x^2}{2} - \frac{1}{6}x^3\right]_0^2}{\left[\frac{2\sqrt{2}}{3}x^{3/2} + \frac{1}{2}x^2\right]_0^2} = 0.143 \text{ m} \quad \text{Ans}$$

$$A = 4.667 \text{ m}^2$$

$$W = 7850(9.81)(4.667)(0.3) = 107.81 \text{ kN}$$

$$(+\Sigma M_A = 0; \quad -1.2571(107.81) + N_B(2\sqrt{2}) = 0$$

$$N_B = 47.92 = 47.9 \text{ kN} \quad \text{Ans}$$

$$(\rightarrow \Sigma F_x = 0; \quad -A_x + 47.92 \sin 45^\circ = 0$$

$$A_x = 33.9 \text{ kN} \quad \text{Ans}$$

$$(+\uparrow \Sigma F_y = 0; \quad A_y + 47.92 \cos 45^\circ - 107.81 = 0$$

$$A_y = 73.9 \text{ kN} \quad \text{Ans}$$

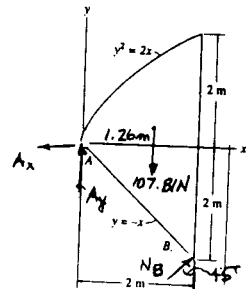
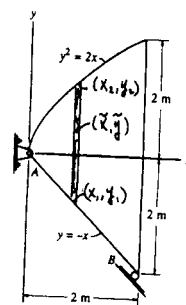

9-23. Locate the centroid \bar{x} of the shaded area.

Area and Moment Arm : Here, $x_1 = \frac{y}{2}$ and $x_2 = \frac{y^2}{4}$. The area of the differential element is $dA = (x_1 - x_2) dy = \left(\frac{y}{2} - \frac{y^2}{4}\right) dy$ and its centroid is $\bar{x} = x_2 + \frac{x_1 - x_2}{2} = \frac{1}{2}(x_1 + x_2) = \frac{1}{2}\left(\frac{y}{2} + \frac{y^2}{4}\right)$.

Centroid : Applying Eq. 9-6 and performing the integration, we have

$$\begin{aligned}\bar{x} &= \frac{\int_A \bar{x} dA}{\int_A dA} = \frac{\int_0^{2\text{ft}} \frac{1}{2} \left(\frac{y}{2} + \frac{y^2}{4}\right) \left[\left(\frac{y}{2} - \frac{y^2}{4}\right) dy\right]}{\int_0^{2\text{ft}} \left(\frac{y}{2} - \frac{y^2}{4}\right) dy} \\ &= \frac{\left[\frac{1}{2} \left(\frac{1}{12} y^3 - \frac{1}{80} y^5\right)\right]_0^{2\text{ft}}}{\left(\frac{1}{4} y^2 - \frac{1}{12} y^3\right)_0^{2\text{ft}}} = \frac{2}{5} \text{ ft} = 0.4 \text{ ft} \quad \text{Ans}\end{aligned}$$

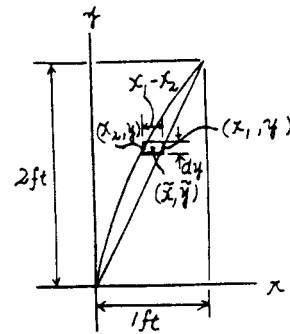
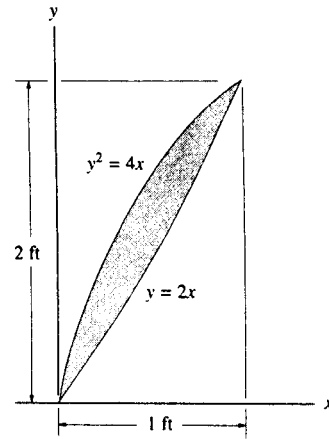

*9-24. Locate the centroid \bar{y} of the shaded area.

Area and Moment Arm : Here, $x_1 = \frac{y}{2}$ and $x_2 = \frac{y^2}{4}$. The area of the differential element is $dA = (x_1 - x_2) dy = \left(\frac{y}{2} - \frac{y^2}{4}\right) dy$ and its centroid is $\bar{y} = y$.

Centroid : Applying Eq. 9-6 and performing the integration, we have

$$\begin{aligned}\bar{y} &= \frac{\int_A \bar{y} dA}{\int_A dA} = \frac{\int_0^{2\text{ft}} y \left[\left(\frac{y}{2} - \frac{y^2}{4}\right) dy\right]}{\int_0^{2\text{ft}} \left(\frac{y}{2} - \frac{y^2}{4}\right) dy} \\ &= \frac{\left(\frac{1}{6} y^3 - \frac{1}{16} y^4\right)_0^{2\text{ft}}}{\left(\frac{1}{4} y^2 - \frac{1}{12} y^3\right)_0^{2\text{ft}}} = 1 \text{ ft} \quad \text{Ans}\end{aligned}$$

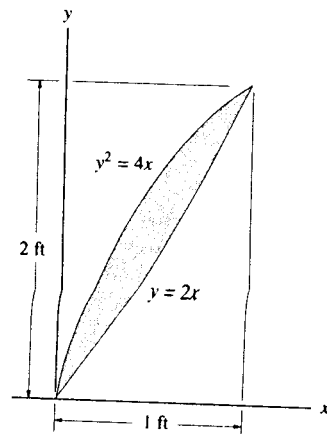

9-25. Locate the centroid \bar{x} of the shaded area.

Area and Moment Arm : Here, $y_1 = x^{\frac{1}{2}}$ and $y_2 = x^2$. The area of the differential element is $dA = (y_1 - y_2) dx = (x^{\frac{1}{2}} - x^2) dx$ and its centroid is $\bar{x} = x$.

Centroid : Applying Eq. 9-6 and performing the integration, we have

$$\begin{aligned} \bar{x} &= \frac{\int_A \bar{x} dA}{\int_A dA} = \frac{\int_0^{1\text{ m}} x [(x^{\frac{1}{2}} - x^2) dx]}{\int_0^{1\text{ m}} (x^{\frac{1}{2}} - x^2) dx} \\ &= \frac{\left(\frac{2}{5}x^{\frac{5}{2}} - \frac{1}{4}x^3\right)\Big|_0^{1\text{ m}}}{\left(\frac{2}{3}x^{\frac{3}{2}} - \frac{1}{3}x^3\right)\Big|_0^{1\text{ m}}} = \frac{9}{20} \text{ m} = 0.45 \text{ m} \quad \text{Ans} \end{aligned}$$

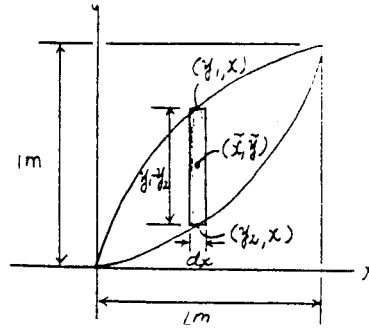
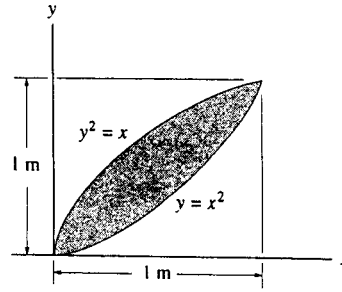

9-26. Locate the centroid \bar{y} of the shaded area.

Area and Moment Arm : Here, $y_1 = x^{\frac{1}{2}}$ and $y_2 = x^2$. The area of the differential element is $dA = (y_1 - y_2) dx = (x^{\frac{1}{2}} - x^2) dx$ and its centroid is $\bar{y} = y_2 + \frac{y_1 - y_2}{2} = \frac{1}{2}(y_1 + y_2) = \frac{1}{2}(x^{\frac{1}{2}} + x^2)$.

Centroid : Applying Eq. 9-6 and performing the integration, we have

$$\begin{aligned} \bar{y} &= \frac{\int_A \bar{y} dA}{\int_A dA} = \frac{\int_0^{1\text{ m}} \frac{1}{2}(x^{\frac{1}{2}} + x^2) [(x^{\frac{1}{2}} - x^2) dx]}{\int_0^{1\text{ m}} (x^{\frac{1}{2}} - x^2) dx} \\ &= \frac{\frac{1}{2}\left(\frac{1}{2}x^{\frac{3}{2}} - \frac{1}{5}x^5\right)\Big|_0^{1\text{ m}}}{\left(\frac{2}{3}x^{\frac{3}{2}} - \frac{1}{3}x^3\right)\Big|_0^{1\text{ m}}} = \frac{9}{20} \text{ m} = 0.45 \text{ m} \quad \text{Ans} \end{aligned}$$

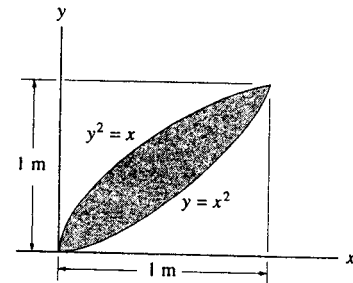

9-27. Locate the centroid \bar{x} of the shaded area.

Area and Moment Arm : The area of the differential element is $dA = ydx$
 $= \frac{1}{x} dx$ and its centroid is $\bar{x} = x$.

Centroid : Applying Eq. 9-6 and performing the integration, we have

$$\bar{x} = \frac{\int_A \bar{x} dA}{\int_A dA} = \frac{\int_{0.5 \text{ in.}}^{2 \text{ in.}} x \left(\frac{1}{x} dx \right)}{\int_{0.5 \text{ in.}}^{2 \text{ in.}} \frac{1}{x} dx} = \frac{x \Big|_{0.5 \text{ in.}}^{2 \text{ in.}}}{\ln x \Big|_{0.5 \text{ in.}}^{2 \text{ in.}}} = 1.08 \text{ in.} \quad \text{Ans}$$

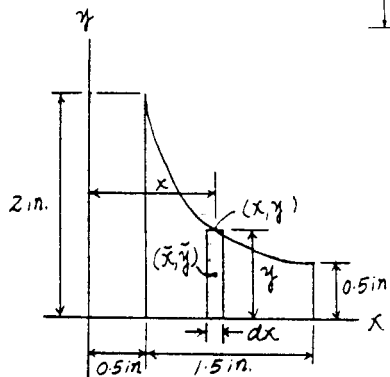
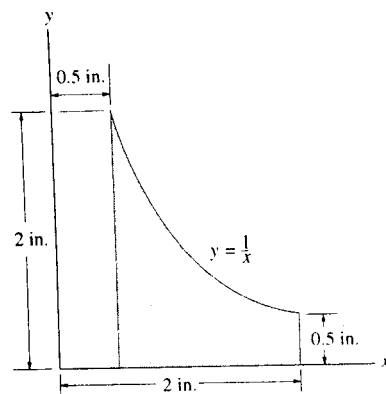

*9-28. Locate the centroid \bar{y} of the shaded area.

Area and Moment Arm : The area of the differential element is $dA = ydx$
 $= \frac{1}{x} dx$ and its centroid is $\bar{y} = \frac{y}{2} = \frac{1}{2x}$.

Centroid : Applying Eq. 9-6 and performing the integration, we have

$$\bar{y} = \frac{\int_A \bar{y} dA}{\int_A dA} = \frac{\int_{0.5 \text{ in.}}^{2 \text{ in.}} \frac{1}{2x} \left(\frac{1}{x} dx \right)}{\int_{0.5 \text{ in.}}^{2 \text{ in.}} \frac{1}{x} dx} = \frac{\frac{1}{2x} \Big|_{0.5 \text{ in.}}^{2 \text{ in.}}}{\ln x \Big|_{0.5 \text{ in.}}^{2 \text{ in.}}} = 0.541 \text{ in} \quad \text{Ans}$$

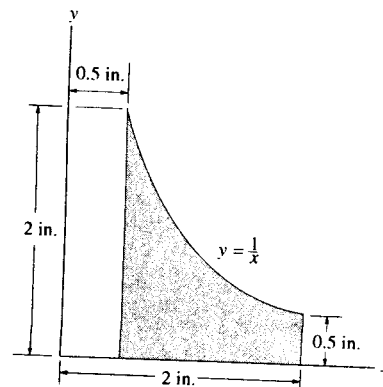

9-29. Locate the centroid \bar{x} of the shaded area.

Area and Moment Arm : The area of the differential element is $dA = ydx = x^2 dx$ and its centroid is $\bar{x} = x$.

Centroid : Applying Eq. 9-6 and performing the integration, we have

$$\bar{x} = \frac{\int_A \bar{x} dA}{\int_A dA} = \frac{\int_{1.1\text{ in.}}^{2.1\text{ in.}} x(x^2 dx)}{\int_{1.1\text{ in.}}^{2.1\text{ in.}} x^2 dx} = \frac{\frac{x^4}{4} \Big|_{1.1\text{ in.}}^{2.1\text{ in.}}}{\frac{x^3}{3} \Big|_{1.1\text{ in.}}^{2.1\text{ in.}}} = 1.61 \text{ in.} \quad \text{Ans}$$

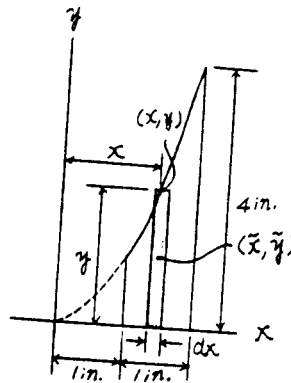
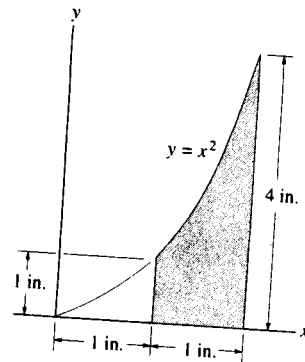

9-30. Locate the centroid \bar{y} of the shaded area.

Area and Moment Arm : The area of the differential element is $dA = ydx = x^2 dx$ and its centroid is $\bar{y} = \frac{y}{2} = \frac{1}{2}x^2$.

Centroid : Applying Eq. 9-6 and performing the integration, we have

$$\bar{y} = \frac{\int_A \bar{y} dA}{\int_A dA} = \frac{\int_{1.1\text{ in.}}^{2.1\text{ in.}} \frac{1}{2}x^2(x^2 dx)}{\int_{1.1\text{ in.}}^{2.1\text{ in.}} x^2 dx} = \frac{\frac{x^5}{5} \Big|_{1.1\text{ in.}}^{2.1\text{ in.}}}{\frac{x^3}{3} \Big|_{1.1\text{ in.}}^{2.1\text{ in.}}} = 1.33 \text{ in.} \quad \text{Ans}$$

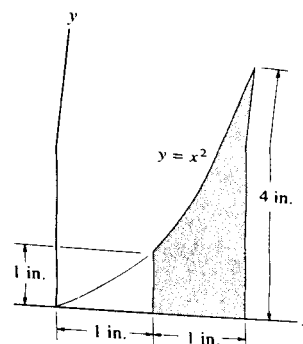

9-31. Determine the location \bar{r} of the centroid C of the cardioid, $r = a(1 - \cos \theta)$.

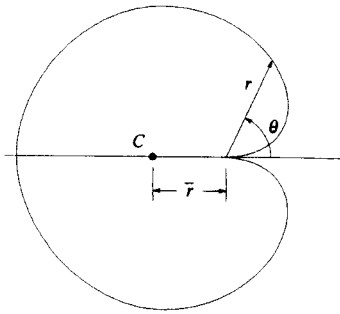

$$dA = \frac{1}{2} r^2 d\theta$$

$$A = 2 \int_0^{\pi} \frac{1}{2} (a^2)(1 - \cos \theta)^2 d\theta = \frac{3}{2} \pi a^2$$

$$\begin{aligned} \int_A \bar{r} dA &= 2 \int_0^{\pi} \left(\frac{2}{3} r \cos \theta\right) \left(\frac{1}{2}\right) (a^2)(1 - \cos \theta)^2 d\theta \\ &= \frac{2}{3} a^3 \int_0^{\pi} (1 - \cos \theta)^3 \cos \theta d\theta = 3.927 a^3 \end{aligned}$$

$$\bar{r} = \frac{\int_A \bar{r} dA}{\int_A dA} = \frac{3.927 a^3}{\frac{3}{2} \pi a^2} = 0.833 a \quad \text{Ans}$$

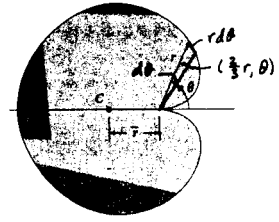

*9-32. Locate the centroid of the ellipsoid of revolution.

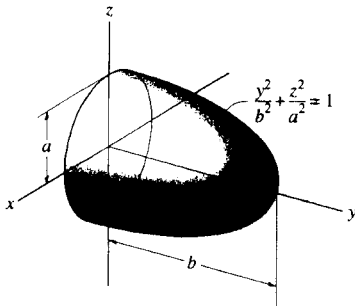

$$dV = \pi z^2 dy$$

$$\int dV = \int_0^b \pi a^2 \left(1 - \frac{y^2}{b^2}\right) dy = \pi a^2 \left[y - \frac{y^3}{3b^2} \right]_0^b = \frac{2\pi a^2 b}{3}$$

$$\int \bar{y} dV = \int_0^b \pi a^2 y \left(1 - \frac{y^2}{b^2}\right) dy = \pi a^2 \left[\frac{y^2}{2} - \frac{y^4}{4b^2} \right]_0^b = \frac{\pi a^2 b^2}{4}$$

$$\bar{y} = \frac{\int_V \bar{y} dV}{\int_V dV} = \frac{\frac{\pi a^2 b^2}{4}}{\frac{2\pi a^2 b}{3}} = \frac{3}{8} b \quad \text{Ans}$$

$$\bar{x} = \bar{z} = 0 \quad \text{Ans} \quad (\text{By symmetry})$$

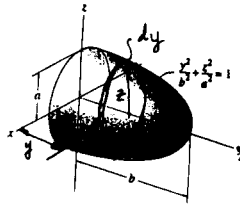

9-33. Locate the center of gravity of the volume. The material is homogeneous.

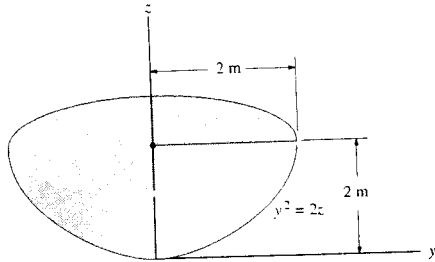

Volume and Moment Arm: The volume of the thin disk differential element is $dV = \pi y^2 dz = \pi(2z)dz = 2\pi z dz$ and its centroid $\bar{z} = z$.

Centroid: Due to symmetry about z axis

$$\bar{x} = \bar{y} = 0 \quad \text{Ans}$$

Applying Eq. 9-5 and performing the integration, we have

$$\begin{aligned} \bar{z} &= \frac{\int_V \bar{z} dV}{\int_V dV} = \frac{\int_0^{2m} z(2\pi z dz)}{\int_0^{2m} 2\pi z dz} \\ &= \frac{2\pi \left(\frac{z^3}{3}\right) \Big|_0^{2m}}{2\pi \left(\frac{z^2}{2}\right) \Big|_0^{2m}} = \frac{4}{3} \text{ m} \quad \text{Ans} \end{aligned}$$

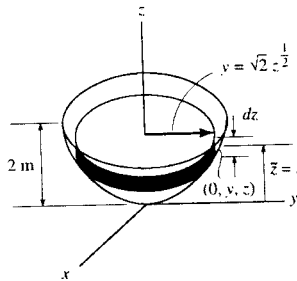

9-34. Locate the centroid \bar{z} of the hemisphere.

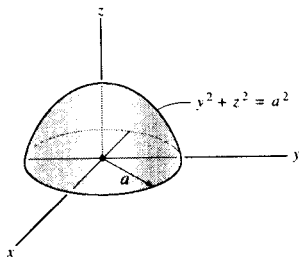

Volume and Moment Arm: The volume of the thin disk differential element is $dV = \pi y^2 dz = \pi(a^2 - z^2)dz$ and its centroid $\bar{z} = z$.

Centroid: Applying Eq. 9-5 and performing the integration, we have

$$\begin{aligned} \bar{z} &= \frac{\int_V \bar{z} dV}{\int_V dV} = \frac{\int_0^a z[\pi(a^2 - z^2)dz]}{\int_0^a \pi(a^2 - z^2)dz} \\ &= \frac{\pi \left(\frac{a^2 z^2}{2} - \frac{z^4}{4}\right) \Big|_0^a}{\pi \left(a^2 z - \frac{z^3}{3}\right) \Big|_0^a} = \frac{3}{8} a \quad \text{Ans} \end{aligned}$$

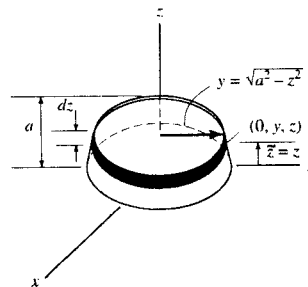

9-35. Locate the centroid of the solid.

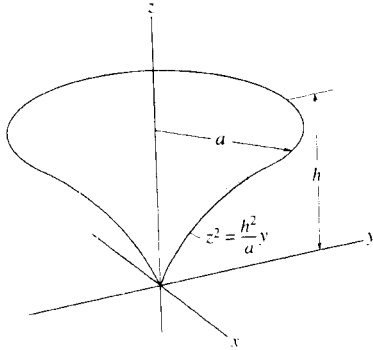

$$\bar{x} = \bar{y} = 0 \quad \text{Ans} \quad (\text{By symmetry})$$

$$\int dV = \int_0^h \pi y^2 dz = \pi \int_0^h \frac{a^2}{h^4} z^4 dz = \left[\frac{\pi a^2}{5h^4} z^5 \right]_0^h = \frac{\pi a^2 h}{5}$$

$$\int \bar{z} dV = \int_0^h \pi y^2 z dz = \frac{\pi a^2}{h^4} \int_0^h z^5 dz = \left[\frac{\pi a^2}{6h^4} z^6 \right]_0^h = \frac{\pi a^2 h^2}{6}$$

$$\bar{z} = \frac{\int_V \bar{z} dV}{\int_V dV} = \frac{\frac{\pi a^2 h^2}{6}}{\frac{\pi a^2 h}{5}} = \frac{5}{6} h \quad \text{Ans}$$

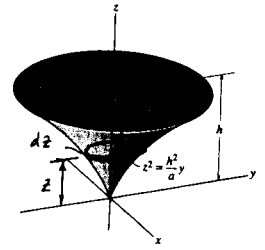

*9-36. Locate the centroid of the quarter-cone.

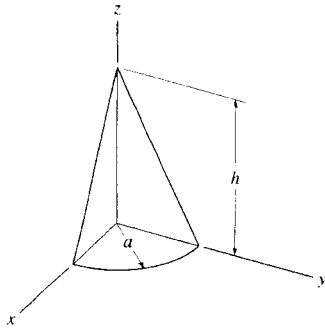

$$\bar{z} = z$$

$$r = \frac{a}{h}(h-z)$$

$$dV = \frac{\pi}{4} r^2 dz = \frac{\pi a^2}{4 h^2} (h-z)^2 dz$$

$$\begin{aligned} \int dV &= \frac{\pi a^2}{4 h^2} \int_0^h (h^2 - 2hz + z^2) dz = \frac{\pi a^2}{4 h^2} \left[h^2 z - h z^2 + \frac{z^3}{3} \right]_0^h \\ &= \frac{\pi a^2}{4 h^2} \left(\frac{h^3}{3} \right) = \frac{\pi a^2 h}{12} \end{aligned}$$

$$\begin{aligned} \int \bar{z} dV &= \frac{\pi a^2}{4 h^2} \int_0^h (h^2 - 2hz + z^2) z dz = \frac{\pi a^2}{4 h^2} \left[h^2 \frac{z^2}{2} - 2h \frac{z^3}{3} + \frac{z^4}{4} \right]_0^h \\ &= \frac{\pi a^2}{4 h^2} \left(\frac{h^4}{12} \right) = \frac{\pi a^2 h^2}{48} \end{aligned}$$

$$\bar{z} = \frac{\int \bar{z} dV}{\int dV} = \frac{\frac{\pi a^2 h^2}{48}}{\frac{\pi a^2 h}{12}} = \frac{h}{4} \quad \text{Ans}$$

$$\begin{aligned} \int \bar{x} dV &= \frac{\pi a^2}{4 h^2} \int_0^h \frac{4r}{3\pi} (h-z)^2 dz = \frac{\pi a^2}{4 h^2} \int_0^h \frac{4a}{3\pi h} (h^3 - 3h^2 z + 3h z^2 - z^3) dz \\ &= \frac{\pi a^2}{4 h^2} \left(h^4 - \frac{3h^4}{2} + h^4 - \frac{h^4}{4} \right) \\ &= \frac{\pi a^2}{4 h^2} \left(\frac{ah^3}{3\pi} \right) = \frac{a^3 h}{12} \end{aligned}$$

$$\bar{x} = \bar{y} = \frac{\int \bar{x} dV}{\int dV} = \frac{\frac{a^3 h}{12}}{\frac{\pi a^2 h}{12}} = \frac{a}{\pi} \quad \text{Ans}$$

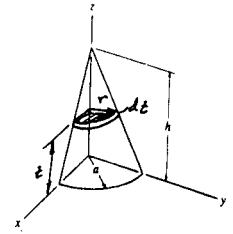

9-37. Locate the center of **MASS** \bar{x} of the hemisphere. The density of the material varies linearly from zero at the origin O to ρ_0 at the surface. *Suggestion:* Choose a hemispherical shell element for integration.

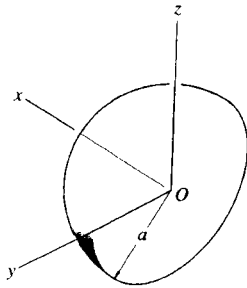

$$\bar{x} = \frac{x}{2}$$

$$\rho = \rho_0 \left(\frac{x}{a}\right)$$

$$dV = 2\pi x^2 dx$$

$$dW = \rho dV = \left(\frac{2\pi}{a}\right) \rho_0 x^3 dx$$

$$\begin{aligned} \bar{x} &= \frac{\int_W \bar{x} dW}{\int_W dW} = \frac{\int_0^a \frac{x}{2} \left(\frac{2\pi}{a}\right) \rho_0 x^3 dx}{\int_0^a \left(\frac{2\pi}{a}\right) \rho_0 x^3 dx} \\ &= \frac{\frac{1}{2} \left[\frac{x^4}{4}\right]_0^a}{\left[\frac{x^4}{4}\right]_0^a} = 0.4 a \quad \text{Ans} \end{aligned}$$

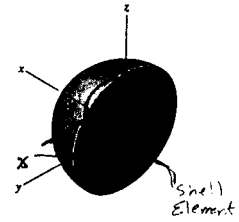

9-38. Locate the centroid \bar{z} of the right-elliptical cone.

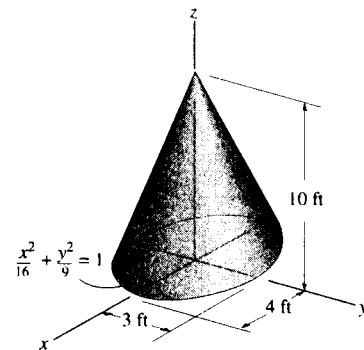

Volume and Moment Arm: From the geometry, $\frac{x}{10-z} = \frac{4}{10}$

$x = 0.4(10-z)$ and $\frac{y}{10-z} = \frac{3}{10}$, $y = 0.3(10-z)$. The volume of the thin disk differential element is $dV = \pi xy dz = \pi [0.4(10-z)][0.3(10-z)] dz = 0.12\pi(z^2 - 20z + 100) dz$ and its centroid $\bar{z} = z$.

Centroid: Applying Eq. 9-5 and performing the integration, we have

$$\begin{aligned} \bar{z} &= \frac{\int_V \bar{z} dV}{\int_V dV} = \frac{\int_0^{10ft} z [0.12\pi(z^2 - 20z + 100)] dz}{\int_0^{10ft} 0.12\pi(z^2 - 20z + 100) dz} \\ &= \frac{0.12\pi \left(\frac{z^4}{4} - \frac{20z^3}{3} + 50z^2 \right) \Big|_0^{10ft}}{0.12\pi \left(\frac{z^3}{3} - 10z^2 + 100z \right) \Big|_0^{10ft}} = 2.50 \text{ ft} \quad \text{Ans} \end{aligned}$$

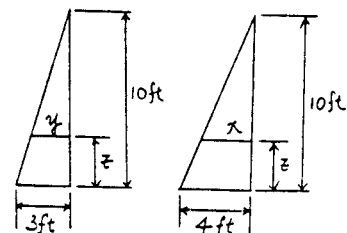
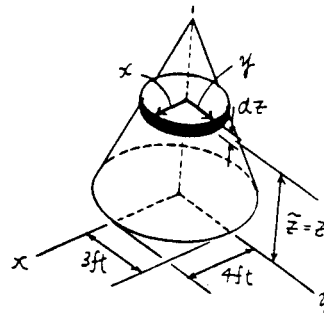

9-39. Locate the centroid \bar{y} of the paraboloid.

Volume and Moment Arm : here, $z = 2y^{\frac{1}{2}}$. The volume of the thin disk differential element is $dV = \pi z^2 dy = \pi(4y) dy$ and its centroid $\bar{y} = y$.

Centroid : Applying Eq. 9-5 and performing the integration, we have

$$\begin{aligned} \bar{y} &= \frac{\int_V \bar{y} dV}{\int_V dV} = \frac{\int_0^{4m} y[\pi(4y) dy]}{\int_0^{4m} \pi(4y) dy} \\ &= \frac{4\pi \left(\frac{y^3}{3}\right) \Big|_0^{4m}}{4\pi \left(\frac{y^2}{2}\right) \Big|_0^{4m}} = 2.67 \text{ m} \end{aligned}$$

Ans

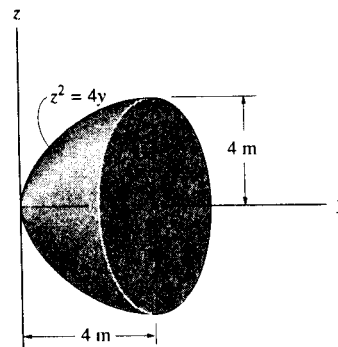
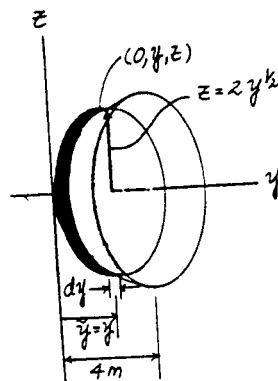

*9-40. The king's chamber of the Great Pyramid of Giza is located at its centroid. Assuming the pyramid to be a solid, prove that this point is at $\bar{z} = \frac{1}{4}h$. *Suggestion:* Use a rectangular differential plate element having a thickness dz and area $(2x)(2y)$.

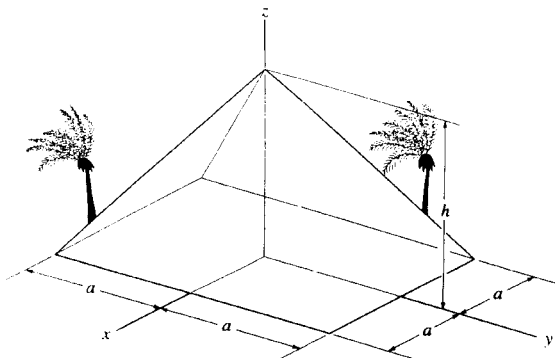

$$dV = (2x)(2y) dz = 4xy dz$$

$$x = y = \frac{a}{h}(h-z)$$

$$\int dV = \int_0^h \frac{4a^2}{h^2}(h-z)^2 dz = \frac{4a^2}{h^2} \left[h^2z - hz^2 + \frac{z^3}{3} \right]_0^h = \frac{4a^2}{3}h$$

$$\int \bar{z} dV = \int_0^h \frac{4a^2}{h^2}(h-z)^2 z dz = \frac{4a^2}{h^2} \left[h^2 \frac{z^2}{2} - 2h \frac{z^3}{3} + \frac{z^4}{4} \right]_0^h = \frac{a^2}{3}h^2$$

$$\bar{z} = \frac{\int \bar{z} dV}{\int dV} = \frac{\frac{a^2 h^2}{3}}{\frac{4a^2 h}{3}} = \frac{h}{4} \quad (\text{QED})$$

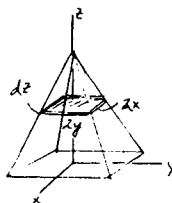

9-41. Locate the centroid \bar{z} of the frustum of the right-circular cone.

Volume and Moment Arm : From the geometry, $\frac{y-r}{R-r} = \frac{h-z}{h}$,
 $y = \frac{(r-R)z + Rh}{h}$. The volume of the thin disk differential element is

$$dV = \pi y^2 dz = \pi \left[\frac{(r-R)z + Rh}{h} \right]^2 dz$$

$$= \frac{\pi}{h^2} [(r-R)^2 z^2 + 2Rh(r-R)z + R^2 h^2] dz$$

and its centroid $\bar{z} = z$.

Centroid : Applying Eq. 9-5 and performing the integration, we have

$$\bar{z} = \frac{\int_V \bar{z} dV}{\int_V dV} = \frac{\int_0^h z \left\{ \frac{\pi}{h^2} [(r-R)^2 z^2 + 2Rh(r-R)z + R^2 h^2] dz \right\}}{\int_0^h \frac{\pi}{h^2} [(r-R)^2 z^2 + 2Rh(r-R)z + R^2 h^2] dz}$$

$$= \frac{\frac{\pi}{h^2} \left[(r-R)^2 \left(\frac{z^4}{4} \right) + 2Rh(r-R) \left(\frac{z^3}{3} \right) + R^2 h^2 \left(\frac{z^2}{2} \right) \right]_0^h}{\frac{\pi}{h^2} \left[(r-R)^2 \left(\frac{z^3}{3} \right) + 2Rh(r-R) \left(\frac{z^2}{2} \right) + R^2 h^2 (z) \right]_0^h}$$

$$= \frac{R^2 + 3r^2 + 2rR}{4(R^2 + r^2 + rR)} h \quad \text{Ans}$$

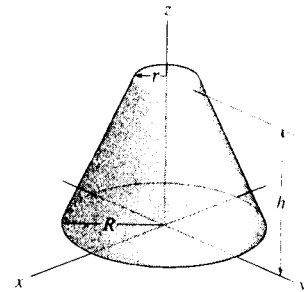
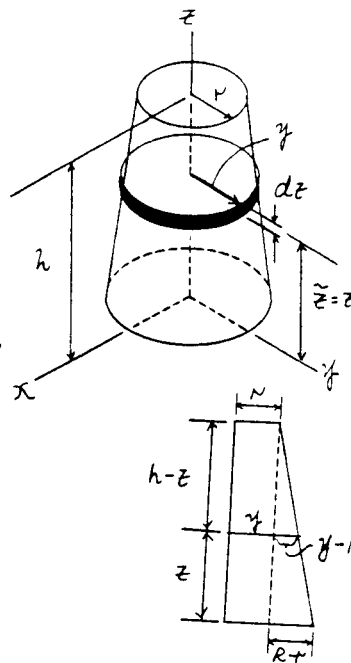

9-42. The hemisphere of radius r is made from a stack of very thin plates such that the density varies with height $\rho = kz$, where k is a constant. Determine its mass and the distance \bar{z} to the center of mass G .

Mass and Moment Arm : The density of the material is $\rho = kz$. The mass of the thin disk differential element is $dm = \rho dV = \rho \pi y^2 dz = kz [\pi (r^2 - z^2)] dz$ and its centroid $\bar{z} = z$. Evaluating the integrals, we have

$$m = \int_m dm = \int_0^r kz [\pi (r^2 - z^2)] dz$$

$$= \pi k \left(\frac{r^2 z^2}{2} - \frac{z^4}{4} \right) \Big|_0^r = \frac{\pi k r^4}{4} \quad \text{Ans}$$

$$\int_m \bar{z} dm = \int_0^r z \{ kz [\pi (r^2 - z^2)] dz \}$$

$$= \pi k \left(\frac{r^2 z^3}{3} - \frac{z^5}{5} \right) \Big|_0^r = \frac{2\pi k r^5}{15}$$

Centroid : Applying Eq. 9-4, we have

$$\bar{z} = \frac{\int_m \bar{z} dm}{\int_m dm} = \frac{2\pi k r^5 / 15}{\pi k r^4 / 4} = \frac{8}{15} r \quad \text{Ans}$$

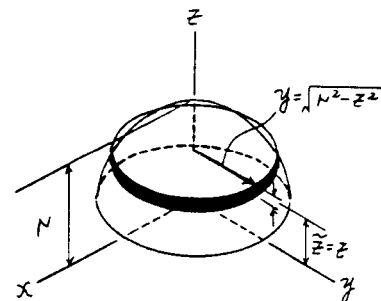
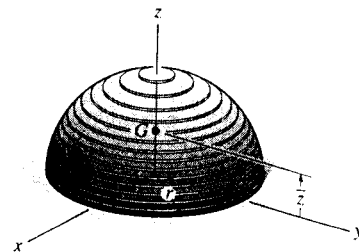

9-43. Determine the location \bar{z} of the centroid for the tetrahedron. *Suggestion:* Use a triangular "plate" element parallel to the x - y plane and of thickness dz .

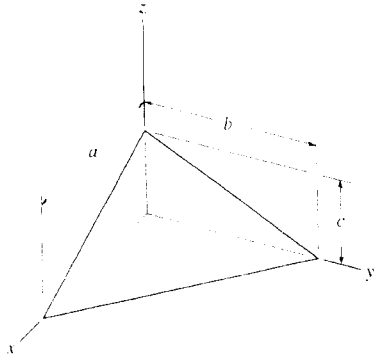

$$z = c(1 - \frac{1}{b}y) = c(1 - \frac{1}{a}x)$$

$$\int dV = \int_0^c \frac{1}{2}(x)(y) dz = \frac{1}{2} \int_0^c b(1 - \frac{z}{c})a(1 - \frac{z}{c}) dz = \frac{abc}{6}$$

$$\int \bar{z} dV = \frac{1}{2} \int_0^c z b(1 - \frac{z}{c})a(1 - \frac{z}{c}) dz = \frac{abc^2}{24}$$

$$\bar{z} = \frac{\int \bar{z} dV}{\int dV} = \frac{\frac{abc^2}{24}}{\frac{abc}{6}} = \frac{c}{4} \quad \text{Ans}$$

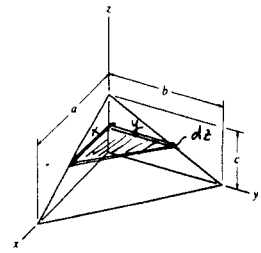

*9-44. Locate the center of gravity G of the five particles with respect to the origin O .

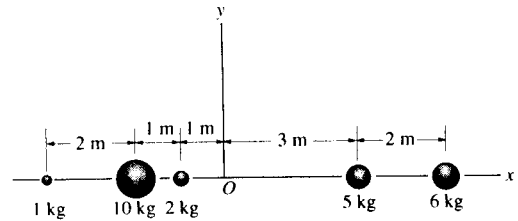

Center of Gravity: The weight of the particles are $W_1 = 5g$, $W_2 = 6g$, $W_3 = 2g$, $W_4 = 10g$ and $W_5 = 1g$ and their respective centers of gravity are $\bar{x}_1 = 3$ m, $\bar{x}_2 = 5$ m, $\bar{x}_3 = -1$ m, $\bar{x}_4 = -2$ m and $\bar{x}_5 = -4$ m. Applying Eq. 9-8, we have

$$\bar{x} = \frac{\Sigma \bar{x}W}{\Sigma W} = \frac{3(5g) + 5(6g) + (-1)(2g) + (-2)(10g) + (-4)(1g)}{5g + 6g + 2g + 10g + 1g}$$

$$= 0.792 \text{ m} \quad \text{Ans}$$

9-45. Locate the center of mass (\bar{x}, \bar{y}) of the four particles.

Center of Gravity: The weight of the particles are $W_1 = 2$ kg, $W_2 = 5$ kg, $W_3 = 2$ kg and $W_4 = 1$ kg. Their respective centers of mass are $\bar{x}_1 = 1$ m and $\bar{y}_1 = 3$ m, $\bar{x}_2 = 2$ m and $\bar{y}_2 = 4$ m, $\bar{x}_3 = 1$ m and $\bar{y}_3 = -2$ m and $\bar{x}_4 = -1$ m and $\bar{y}_4 = 1$ m. Applying Eq. 9-8, we have

$$\bar{x} = \frac{\Sigma \bar{x}W}{\Sigma W} = \frac{1(2) + 2(5) + 1(2) + (-1)(1)}{2 + 5 + 2 + 1}$$

$$= 1.30 \text{ m} \quad \text{Ans}$$

$$\bar{y} = \frac{\Sigma \bar{y}W}{\Sigma W} = \frac{3(2) + 4(5) + (-2)(2) + 1(1)}{2 + 5 + 2 + 1}$$

$$= 2.30 \text{ m} \quad \text{Ans}$$

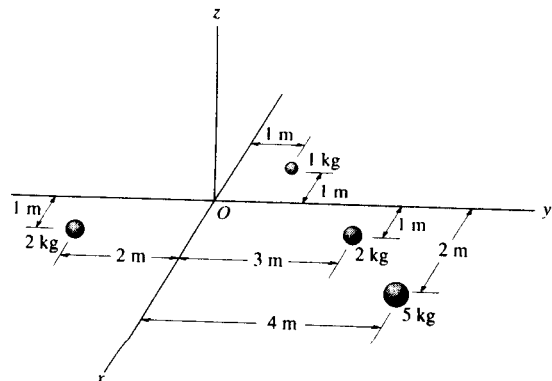

9-46. Locate the centroid (\bar{x} , \bar{y}) of the uniform wire bent in the shape shown.

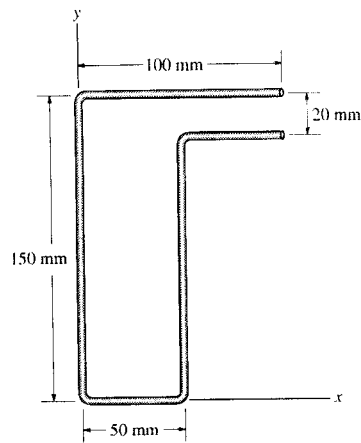

Centroid: The length of each segment and its respective centroid are tabulated below.

| Segment | L (mm) | \bar{x} (mm) | \bar{y} (mm) | $\bar{x}L$ (mm ²) | $\bar{y}L$ (mm ²) |
|----------|----------|----------------|----------------|-------------------------------|-------------------------------|
| 1 | 150 | 0 | 75 | 0 | 11250 |
| 2 | 50 | 25 | 0 | 1250 | 0 |
| 3 | 130 | 50 | 65 | 6500 | 8450 |
| 4 | 100 | 50 | 150 | 5000 | 15000 |
| 5 | 50 | 75 | 130 | 3750 | 6500 |
| Σ | 480 | | | 16500 | 41200 |

Thus,

$$\bar{x} = \frac{\Sigma \bar{x}L}{\Sigma L} = \frac{16500}{480} = 34.375 \text{ mm} = 34.4 \text{ mm} \quad \text{Ans}$$

$$\bar{y} = \frac{\Sigma \bar{y}L}{\Sigma L} = \frac{41200}{480} = 85.83 \text{ mm} = 85.8 \text{ mm} \quad \text{Ans}$$

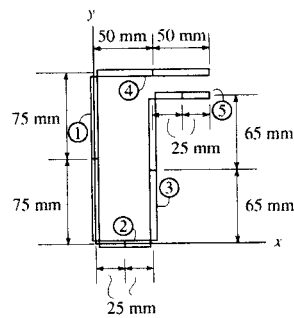

9-47. The steel and aluminum plate assembly is bolted together and fastened to the wall. Each plate has a constant width in the z direction of 200 mm and thickness of 20 mm. If the density of A and B is $\rho_s = 7.85 \text{ Mg/m}^3$, and for C , $\rho_{al} = 2.71 \text{ Mg/m}^3$, determine the location \bar{x} of the center of mass. Neglect the size of the bolts.

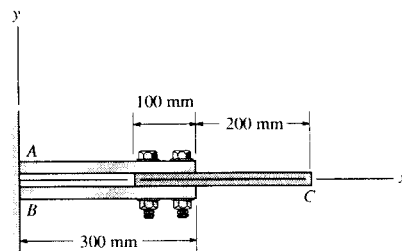

$$\begin{aligned} \Sigma m &= 2[7.85(10)^3(0.3)(0.2)(0.02)] + 2.71(10)^3(0.3)(0.2)(0.02) \\ &= 22.092 \text{ kg} \end{aligned}$$

$$\begin{aligned} \Sigma \bar{x}m &= 150[2[7.85(10)^3(0.3)(0.2)(0.02)]] \\ &\quad + 350[2.71(10)^3(0.3)(0.2)(0.02)] \\ &= 3964.2 \text{ kg}\cdot\text{mm} \end{aligned}$$

$$\bar{x} = \frac{\Sigma \bar{x}m}{\Sigma m} = \frac{3964.2}{22.092} = 179 \text{ mm}$$

Ans

*9-48. The truss is made from five members, each having a length of 4 m and a mass of 7 kg/m. If the mass of the gusset plates at the joints and the thickness of the members can be neglected, determine the distance d to where the hoisting cable must be attached, so that the truss does not tip (rotate) when it is lifted.

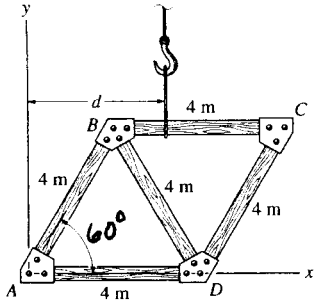

$$\Sigma \bar{x} M = 4(7)(1+4+2+3+5) = 420 \text{ kg} \cdot \text{m}$$

$$\Sigma M = 4(7)(5) = 140 \text{ kg}$$

$$d = \bar{x} = \frac{\Sigma \bar{x} M}{\Sigma M} = \frac{420}{140} = 3 \text{ m} \quad \text{Ans}$$

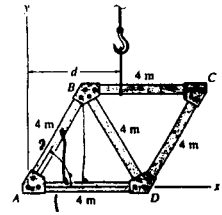

9-49. Locate the centroid for the wire. Neglect the thickness of the material and slight bends at the corners.

Centroid: The length of each segment and its respective centroid are tabulated below.

| Segment | $L(\text{in.})$ | $\bar{y}(\text{in.})$ | $\bar{y}L(\text{in}^2)$ |
|----------|-----------------|-----------------------|-------------------------|
| 1 | 3 | 9.5 | 28.5 |
| 2 | 5 | 9.5 | 47.5 |
| 3 | 8 | 4 | 32.0 |
| 4 | 10 | 0 | 0 |
| 5 | 8 | 4 | 32.0 |
| 6 | 5 | 9.5 | 47.5 |
| 7 | 3 | 9.5 | 28.5 |
| Σ | 42.0 | | 216.0 |

Due to symmetry about y axis, $\bar{x} = 0$

$$\bar{y} = \frac{\Sigma \bar{y}L}{\Sigma L} = \frac{216.0}{42.0} = 5.143 \text{ in.} = 5.14 \text{ in.}$$

Ans

Ans

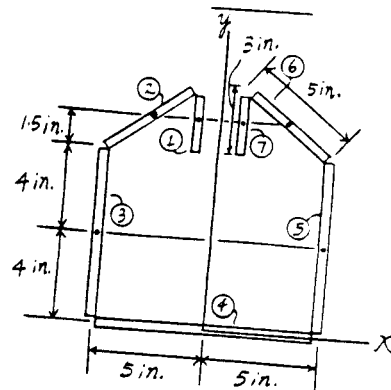
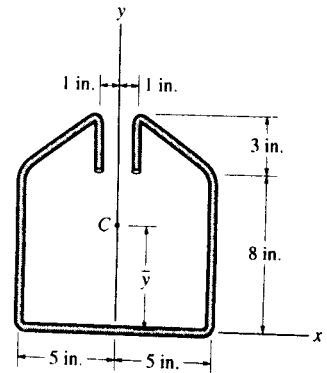

9-50. Locate the centroid (\bar{x}, \bar{y}) of the metal cross section. Neglect the thickness of the material and slight bends at the corners.

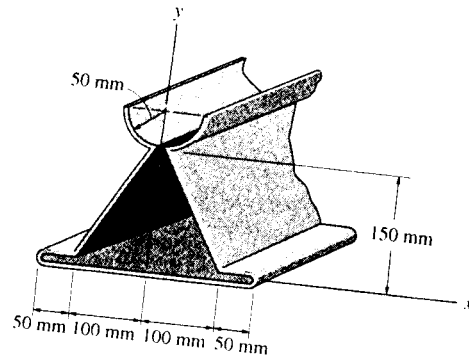

Centroid: The length of each segment and its respective centroid are tabulated below.

| Segment | L (mm) | \bar{y} (mm) | $\bar{y}L$ (mm ²) |
|----------|----------|----------------|-------------------------------|
| 1 | 50π | 168.17 | 26415.93 |
| 2 | 180.28 | 75 | 13520.82 |
| 3 | 400 | 0 | 0 |
| 4 | 180.28 | 75 | 13520.82 |
| Σ | 917.63 | | 53457.56 |

Due to symmetry about y axis, $\bar{x} = 0$

Ans

$$\bar{y} = \frac{\Sigma \bar{y}L}{\Sigma L} = \frac{53457.56}{917.63} = 58.26 \text{ mm} = 58.3 \text{ mm}$$

Ans

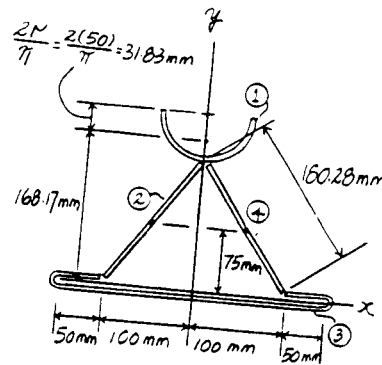

9-51. The three members of the frame each have a weight per unit length of 4 lb/ft. Locate the position (\bar{x}, \bar{y}) of the center of gravity. Neglect the size of the pins at the joints and the thickness of the members. Also, calculate the reactions at the fixed support A .

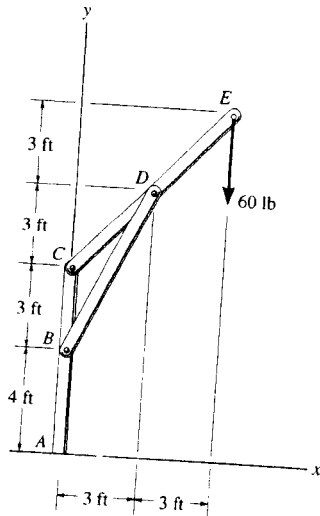

$$\Sigma \bar{x}W = 1.5(4)\sqrt{45} + 3(4)\sqrt{72} = 142.073 \text{ lb}\cdot\text{ft}$$

$$\Sigma W = 4(7) + 4\sqrt{45} + 4\sqrt{72} = 88.774 \text{ lb}$$

$$\bar{x} = \frac{\Sigma \bar{x}W}{\Sigma W} = \frac{142.073}{88.774} = 1.60 \text{ ft} \quad \text{Ans}$$

$$\Sigma \bar{y}W = 3.5(4)(7) + 7(4)\sqrt{45} + 10(4)\sqrt{72} = 625.241 \text{ lb}\cdot\text{ft}$$

$$\bar{y} = \frac{\Sigma \bar{y}W}{\Sigma W} = \frac{625.241}{88.774} = 7.04 \text{ ft} \quad \text{Ans}$$

$$\rightarrow \Sigma F_x = 0; \quad A_x = 0$$

Ans

$$+ \uparrow \Sigma F_y = 0; \quad A_y = 88.774 + 60 = 149 \text{ lb}$$

Ans

$$\curvearrowright + \Sigma M_A = 0; \quad -60(6) - 88.774(1.60) + M_A = 0$$

$$M_A = 502 \text{ lb}\cdot\text{ft}$$

Ans

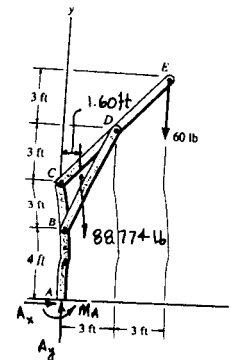

*9-52. Each of the three members of the frame has a mass per unit length of 6 kg/m. Locate the position (\bar{x}, \bar{y}) of the center of gravity. Neglect the size of the pins at the joints and the thickness of the members. Also, calculate the reactions at the pin A and roller E .

Centroid: The length of each segment and its respective centroid are tabulated below.

| Segment | L (m) | \bar{x} (m) | \bar{y} (m) | $\bar{x}L$ (m ²) | $\bar{y}L$ (m ²) |
|----------|---------|---------------|---------------|------------------------------|------------------------------|
| 1 | 8 | 4 | 13 | 32.0 | 104.0 |
| 2 | 7.211 | 2 | 10 | 14.42 | 72.11 |
| 3 | 13 | 0 | 6.5 | 0 | 84.5 |
| Σ | 28.211 | | | 46.42 | 260.61 |

Thus,

$$\bar{x} = \frac{\Sigma \bar{x}L}{\Sigma L} = \frac{46.42}{28.211} = 1.646 \text{ m} = 1.65 \text{ m} \quad \text{Ans}$$

$$\bar{y} = \frac{\Sigma \bar{y}L}{\Sigma L} = \frac{260.61}{28.211} = 9.238 \text{ m} = 9.24 \text{ m} \quad \text{Ans}$$

Equations of Equilibrium: The total weight of the frame is $W = 28.211(6) = 1660.51 \text{ N}$.

$$+\Sigma M_A = 0; \quad E_y(8) - 1660.51(1.646) = 0$$

$$E_y = 341.55 \text{ N} = 342 \text{ N} \quad \text{Ans}$$

$$+\uparrow \Sigma F_y = 0; \quad A_y + 341.55 - 1660.51 = 0$$

$$A_y = 1318.95 \text{ N} = 1.32 \text{ kN} \quad \text{Ans}$$

$$\rightarrow \Sigma F_x = 0; \quad A_x = 0 \quad \text{Ans}$$

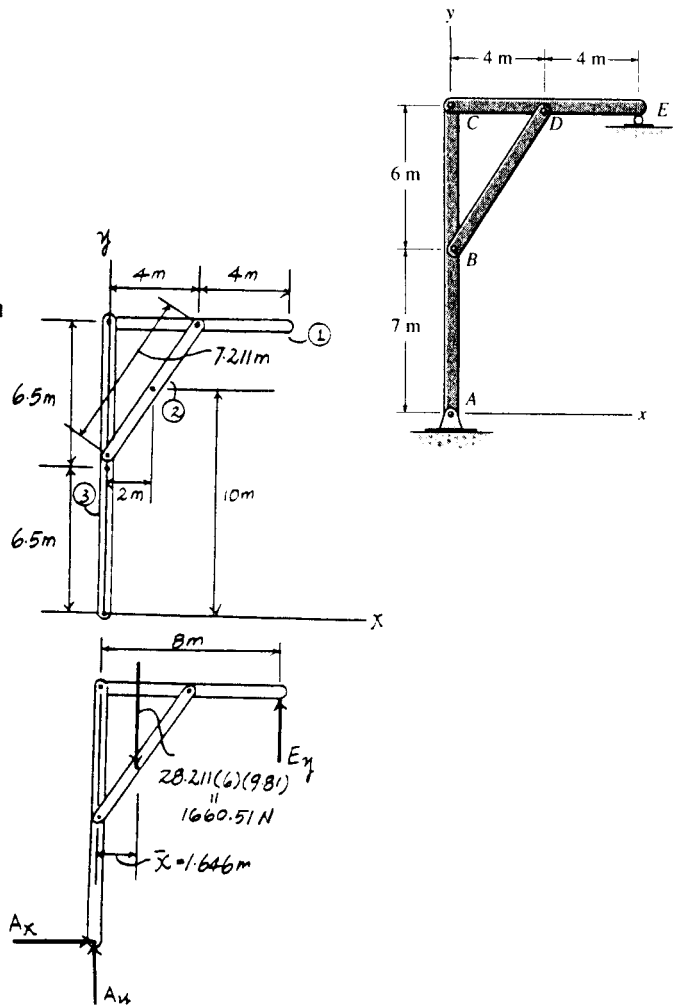

9-53. Determine the location \bar{y} of the centroid of the beam's cross-sectional area. Neglect the size of the corner fillets at A and B for the calculation.

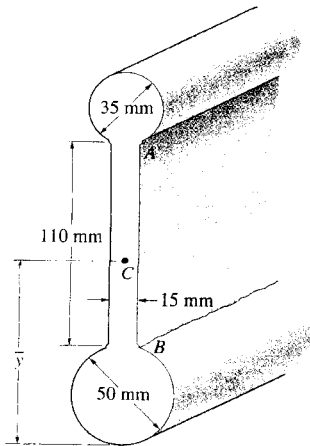

$$\Sigma \bar{y}A = \pi(25)^2(25) + 15(110)(50 + 55) + \pi\left(\frac{35}{2}\right)^2\left(50 + 110 + \frac{35}{2}\right) = 393\,112 \text{ mm}^3$$

$$\Sigma A = \pi(25)^2 + 15(110) + \pi\left(\frac{35}{2}\right)^2 = 4575.6 \text{ mm}^2$$

$$\bar{y} = \frac{\Sigma \bar{y}A}{\Sigma A} = \frac{393\,112}{4575.6} = 85.9 \text{ mm} \quad \text{Ans}$$

9-54. The gravity wall is made of concrete. Determine the location (\bar{x}, \bar{y}) of the center of gravity G for the wall

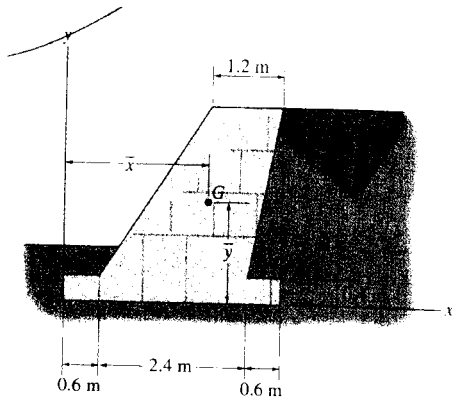

$$\Sigma \bar{x}A = 1.8(3.6)(0.4) + 2.1(3)(3) - 3.4\left(\frac{1}{2}\right)(3)(0.6) - 1.2\left(\frac{1}{2}\right)(1.8)(3)$$

$$= 15.192 \text{ m}^3$$

$$\Sigma \bar{y}A = 0.2(3.6)(0.4) + 1.9(3)(3) - 1.4\left(\frac{1}{2}\right)(3)(0.6) - 2.4\left(\frac{1}{2}\right)(1.8)(3)$$

$$= 9.648 \text{ m}^3$$

$$\Sigma A = 3.6(0.4) + 3(3) - \frac{1}{2}(3)(0.6) - \frac{1}{2}(1.8)(3)$$

$$= 6.84 \text{ m}^2$$

$$\bar{x} = \frac{\Sigma \bar{x}A}{\Sigma A} = \frac{15.192}{6.84} = 2.22 \text{ m} \quad \text{Ans}$$

$$\bar{y} = \frac{\Sigma \bar{y}A}{\Sigma A} = \frac{9.648}{6.84} = 1.41 \text{ m} \quad \text{Ans}$$

9-55. An aluminum strut has a cross section referred to as a deep hat. Locate the centroid \bar{y} of its area. Each segment has a thickness of 10 mm.

Centroid: The area of each segment and its respective centroid are tabulated below.

| Segment | A (mm ²) | \bar{y} (mm) | $\bar{y}A$ (mm ³) |
|----------|------------------------|----------------|-------------------------------|
| 1 | 40(10) | 5 | 2 000 |
| 2 | 100(20) | 50 | 100 000 |
| 3 | 60(10) | 95 | 57 000 |
| Σ | 3 000 | | 159 000 |

Thus,

$$\bar{y} = \frac{\Sigma \bar{y}A}{\Sigma A} = \frac{159 000}{3 000} = 53.0 \text{ mm} \quad \text{Ans}$$

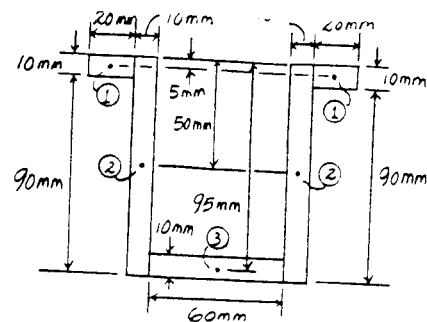
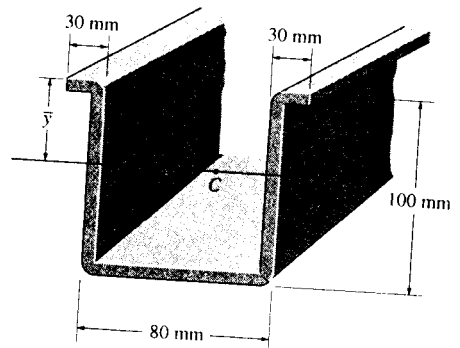

*9-56. Locate the centroid \bar{y} for the cross-sectional area of the angle.

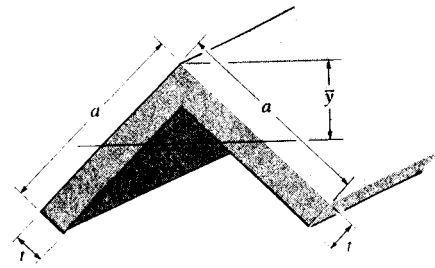

Centroid : The area and the centroid for segments 1 and 2 are

$$A_1 = t(a-t)$$

$$\bar{y}_1 = \left(\frac{a-t}{2} + \frac{t}{2}\right) \cos 45^\circ + \frac{t}{2 \cos 45^\circ} = \frac{\sqrt{2}}{4}(a+2t)$$

$$A_2 = at$$

$$\bar{y}_2 = \left(\frac{a}{2} - \frac{t}{2}\right) \cos 45^\circ + \frac{t}{2 \cos 45^\circ} = \frac{\sqrt{2}}{4}(a+t)$$

Listed in a tabular form, we have

| Segment | A | \bar{y} | $\bar{y}A$ |
|----------|-----------|----------------------------|--|
| 1 | $t(a-t)$ | $\frac{\sqrt{2}}{4}(a+2t)$ | $\frac{\sqrt{2}t}{4}(a^2 + at - 2t^2)$ |
| 2 | at | $\frac{\sqrt{2}}{4}(a+t)$ | $\frac{\sqrt{2}t}{4}(a^2 + at)$ |
| Σ | $t(2a-t)$ | | $\frac{\sqrt{2}t}{2}(a^2 + at - t^2)$ |

Thus,

$$\bar{y} = \frac{\Sigma \bar{y}A}{\Sigma A} = \frac{\frac{\sqrt{2}t}{2}(a^2 + at - t^2)}{t(2a-t)}$$

$$= \frac{\sqrt{2}(a^2 + at - t^2)}{2(2a-t)}$$

Ans

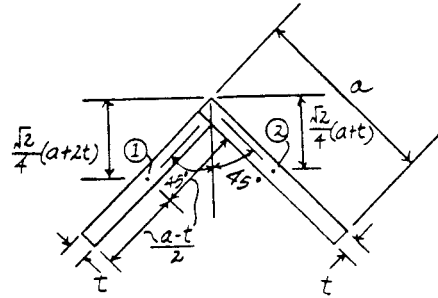

9-57. Determine the location \bar{y} of the centroidal axis \bar{x} of the beam's cross-sectional area. Neglect the size of the corner welds at A and B for the calculation.

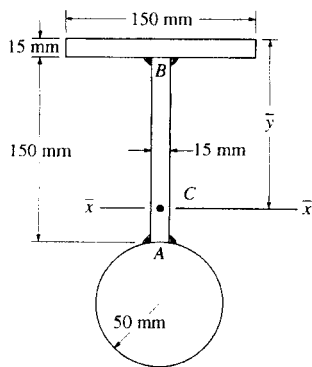

$$\Sigma \bar{y}A = 7.5(15)(150) + 90(150)(15) + 215(\pi)(50)^2$$

$$= 1\,907\,981.05 \text{ mm}^3$$

$$\Sigma A = 15(150) + 150(15) + \pi(50)^2$$

$$= 12\,353.98 \text{ mm}^2$$

$$\bar{y} = \frac{\Sigma \bar{y}A}{\Sigma A} = \frac{1\,907\,981.05}{12\,353.98} = 154 \text{ mm}$$

Ans

9-58. Determine the location (\bar{x}, \bar{y}) of the centroid C of the area.

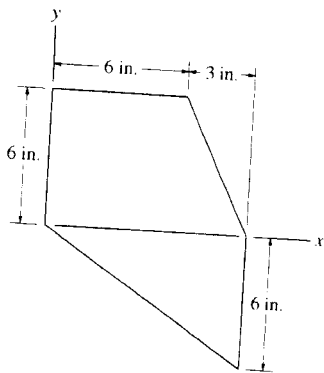

$$\Sigma \bar{x}A = 3(6)(6) + 7\left(\frac{1}{2}\right)(6)(3) + 6\left(\frac{1}{2}\right)(9)(6) = 333 \text{ in}^3$$

$$\Sigma \bar{y}A = 3(6)(6) + 2\left(\frac{1}{2}\right)(6)(3) - 2\left(\frac{1}{2}\right)(9)(6) = 72 \text{ in}^3$$

$$\Sigma A = 6(6) + \frac{1}{2}(6)(3) + \frac{1}{2}(9)(6) = 72 \text{ in}^2$$

$$\bar{x} = \frac{\Sigma \bar{x}A}{\Sigma A} = \frac{333}{72} = 4.625 = 4.62 \text{ in.} \quad \text{Ans}$$

$$\bar{y} = \frac{\Sigma \bar{y}A}{\Sigma A} = \frac{72}{72} = 1.00 \text{ in.} \quad \text{Ans}$$

9-59. Locate the centroid (\bar{x}, \bar{y}) for the angle's cross-sectional area.

Centroid: The area of each segment and its respective centroid are tabulated below.

| Segment | A (in ²) | \bar{x} (in.) | \bar{y} (in.) | $\bar{x}A$ (in ³) | $\bar{y}A$ (in ³) |
|----------|----------------------|-----------------|-----------------|-------------------------------|-------------------------------|
| 1 | 6(2) | 1 | 3 | 12.0 | 36.0 |
| 2 | 6(2) | 5 | 1 | 60.0 | 12.0 |
| Σ | 24.0 | | | 72.0 | 48.0 |

Thus,

$$\bar{x} = \frac{\Sigma \bar{x}A}{\Sigma A} = \frac{72.0}{24.0} = 3.00 \text{ in.} \quad \text{Ans}$$

$$\bar{y} = \frac{\Sigma \bar{y}A}{\Sigma A} = \frac{48.0}{24.0} = 2.00 \text{ in.} \quad \text{Ans}$$

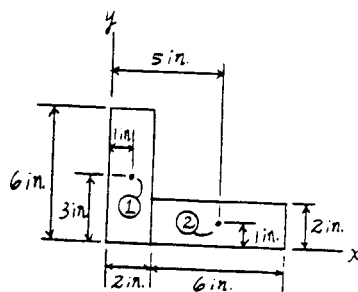
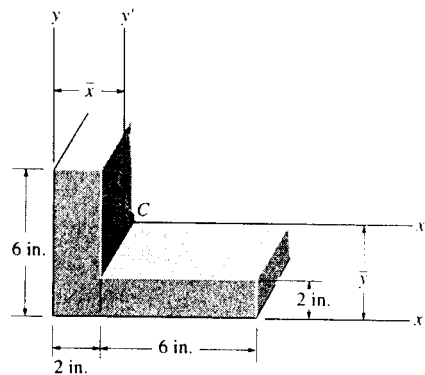

*9-60. The wooden table is made from a square board having a weight of 15 lb. Each of the legs weighs 2 lb and is 3 ft long. Determine how high its center of gravity is from the floor. Also, what is the angle, measured from the horizontal, through which its top surface can be tilted on two of its legs before it begins to overturn? Neglect the thickness of each leg.

$$\bar{z} = \frac{\Sigma \bar{z} W}{\Sigma W} = \frac{15(3) + 4(2)(1.5)}{15 + 4(2)} = 2.48 \text{ ft}$$

Ans

$$\theta = \tan^{-1}\left(\frac{2}{2.48}\right) = 38.9^\circ$$

Ans

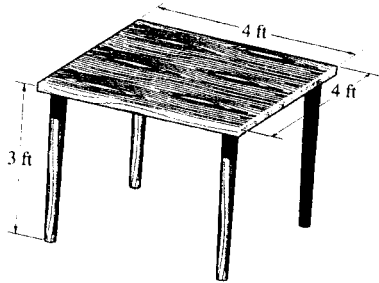
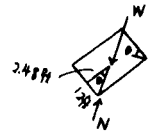

9-61. Locate the centroid \bar{y} of the cross-sectional area of the beam.

Centroid: The area of each segment and its respective centroid are tabulated below.

| Segment | A (in ²) | \bar{y} (in.) | $\bar{y}A$ (in ³) |
|----------|----------------------|-----------------|-------------------------------|
| 1 | 14(1) | 15.5 | 217.0 |
| 2 | 6(2) | 13 | 156.0 |
| 3 | 16(1) | 8 | 128.0 |
| Σ | 42.0 | | 501.0 |

Thus,

$$\bar{y} = \frac{\Sigma \bar{y}A}{\Sigma A} = \frac{501.0}{42.0} = 11.93 \text{ in.} = 11.9 \text{ in.} \quad \text{Ans}$$

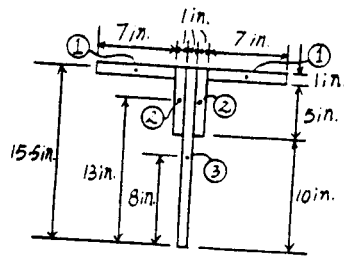
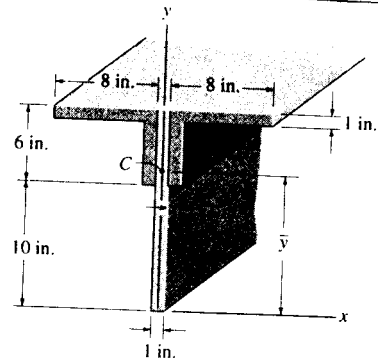

9-62. Determine the location \bar{x} of the centroid C of the shaded area which is part of a circle having a radius r .

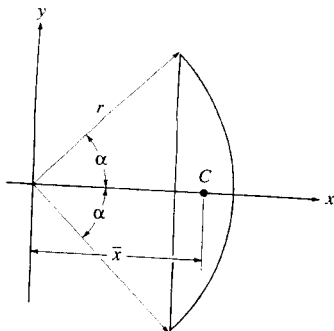

$$\Sigma \bar{x} A = \frac{1}{2} r^2 \alpha \left(\frac{2r}{3\alpha} \sin \alpha \right) - \frac{1}{2} (r \sin \alpha) (r \cos \alpha) \left(\frac{2}{3} r \cos \alpha \right)$$

$$= \frac{r^3}{3} \sin \alpha - \frac{r^3}{3} \sin \alpha \cos^2 \alpha$$

$$= \frac{r^3}{3} \sin^3 \alpha$$

$$\Sigma A = \frac{1}{2} r^2 \alpha - \frac{1}{2} (r \sin \alpha) (r \cos \alpha)$$

$$= \frac{1}{2} r^2 \left(\alpha - \frac{\sin 2\alpha}{2} \right)$$

$$\bar{x} = \frac{\Sigma \bar{x} A}{\Sigma A} = \frac{\frac{r^3}{3} \sin^3 \alpha}{\frac{1}{2} r^2 \left(\alpha - \frac{\sin 2\alpha}{2} \right)} = \frac{\frac{2}{3} r \sin^3 \alpha}{\alpha - \frac{\sin 2\alpha}{2}} \quad \text{Ans}$$

9-63. Locate the centroid \bar{y} of the channel's cross-sectional area.

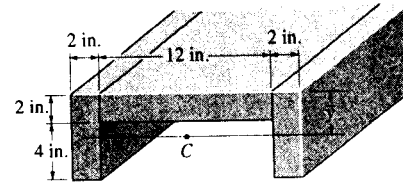

Centroid : The area of each segment and its respective centroid are tabulated below.

| Segment | A (in ²) | \bar{y} (in.) | $\bar{y}A$ (in ³) |
|----------|----------------------|-----------------|-------------------------------|
| 1 | 6(4) | 3 | 72.0 |
| 2 | 12(2) | 1 | 24.0 |
| Σ | 48.0 | | 96.0 |

Thus,

$$\bar{y} = \frac{\Sigma \bar{y}A}{\Sigma A} = \frac{96.0}{48.0} = 2.00 \text{ in.} \quad \text{Ans}$$

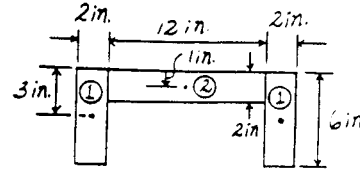

*9-64. Locate the centroid \bar{y} of the cross-sectional area of the beam constructed from a channel and a plate. Assume all corners are square and neglect the size of the weld at A.

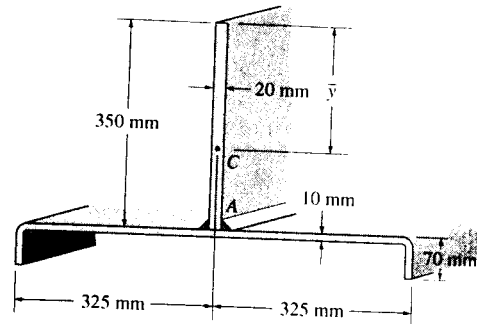

Centroid : The area of each segment and its respective centroid are tabulated below.

| Segment | A (mm ²) | \bar{y} (mm) | $\bar{y}A$ (mm ³) |
|----------|----------------------|----------------|-------------------------------|
| 1 | 350(20) | 175 | 1 225 000 |
| 2 | 630(10) | 355 | 2 236 500 |
| 3 | 70(20) | 385 | 539 000 |
| Σ | 14 700 | | 4 000 500 |

Thus,

$$\bar{y} = \frac{\Sigma \bar{y}A}{\Sigma A} = \frac{4\,000\,500}{14\,700} = 272.14 \text{ mm} = 272 \text{ mm} \quad \text{Ans}$$

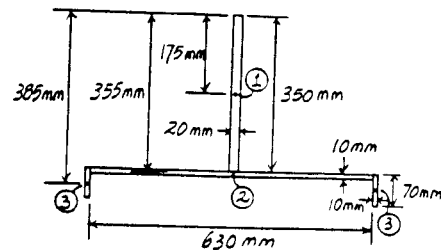

9-65. Locate the centroid (\bar{x}, \bar{y}) of the member's cross-sectional area.

Centroid: The area of each segment and its respective centroid are tabulated below.

| Segment | A (mm ²) | \bar{x} (mm) | \bar{y} (mm) | $\bar{x}A$ (mm ³) | $\bar{y}A$ (mm ³) |
|----------|------------------------|----------------|----------------|-------------------------------|-------------------------------|
| 1 | $\frac{1}{2}(30)(90)$ | 20 | 30 | 27 000 | 40 500 |
| 2 | $30(90)$ | 45 | 45 | 121 500 | 121 500 |
| 3 | $100(50)$ | 110 | 25 | 550 000 | 125 000 |
| Σ | 9 050 | | | 698 500 | 287 000 |

Thus,

$$\bar{x} = \frac{\Sigma \bar{x}A}{\Sigma A} = \frac{698\,500}{9\,050} = 77.18 \text{ mm} = 77.2 \text{ mm} \quad \text{Ans}$$

$$\bar{y} = \frac{\Sigma \bar{y}A}{\Sigma A} = \frac{287\,000}{9\,050} = 31.71 \text{ mm} = 31.7 \text{ mm} \quad \text{Ans}$$

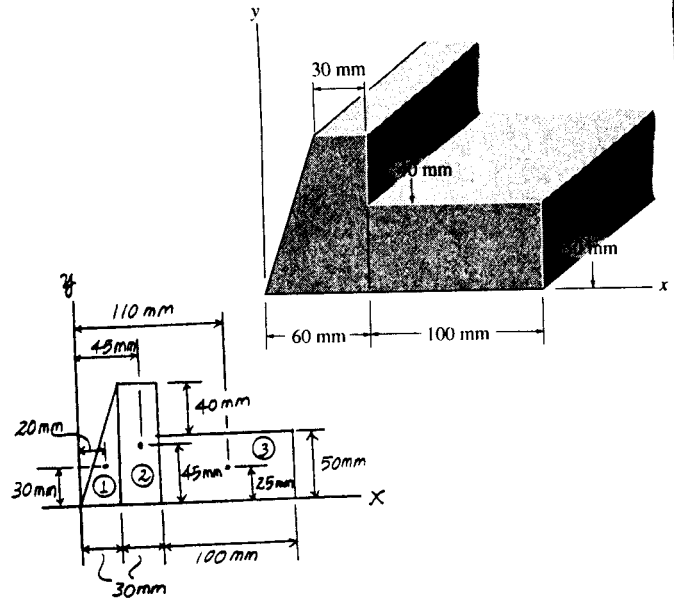

9-66. Locate the centroid \bar{y} of the concrete beam having the tapered cross section shown.

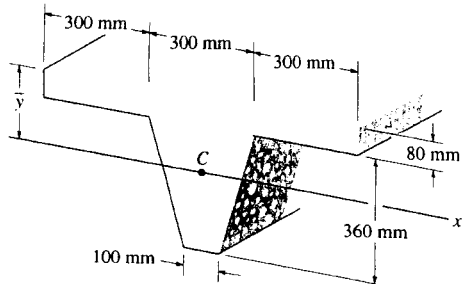

$$\Sigma \bar{y}A = 900(80)(40) + 100(360)(260) + 2\left[\frac{1}{2}(100)(360)(200)\right] = 19.44(10^6) \text{ mm}^3$$

$$\Sigma A = 900(80) + 100(360) + 2\left[\frac{1}{2}(100)(360)\right] = 0.144(10^6) \text{ mm}^2$$

$$\bar{y} = \frac{\Sigma \bar{y}A}{\Sigma A} = \frac{19.44(10^6)}{0.144(10^6)} = 135 \text{ mm} \quad \text{Ans}$$

9-67. Locate the centroid \bar{y} of the beam's cross-section built up from a channel and a wide-flange beam.

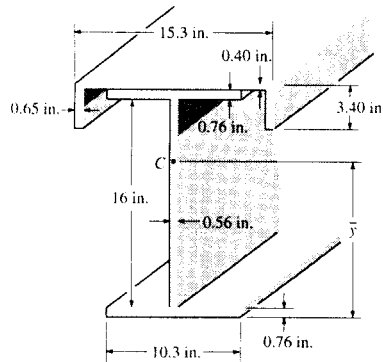

Centroid: The area of each segment and its respective centroid are tabulated below.

| Segment | $A(\text{in}^2)$ | $\bar{y}(\text{in.})$ | $\bar{y}A(\text{in}^3)$ |
|----------|------------------|-----------------------|-------------------------|
| 1 | 14.0(0.4) | 16.20 | 90.72 |
| 2 | 3.40(1.30) | 14.70 | 64.97 |
| 3 | 10.3(0.76) | 15.62 | 122.27 |
| 4 | 14.48(0.56) | 8.00 | 64.87 |
| 5 | 10.3(0.76) | 0.38 | 2.97 |
| Σ | 33.78 | | 345.81 |

Thus,

$$\bar{y} = \frac{\Sigma \bar{y}A}{\Sigma A} = \frac{345.81}{33.78} = 10.24 \text{ in.} = 10.2 \text{ in.} \quad \text{Ans}$$

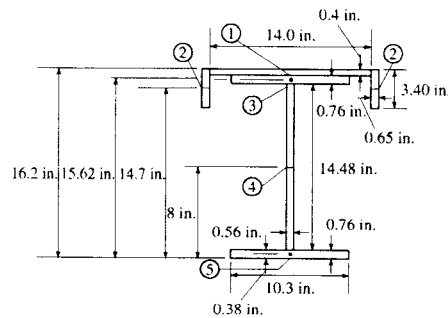

*9-68. Locate the centroid \bar{y} of the bulb-tee cross section.

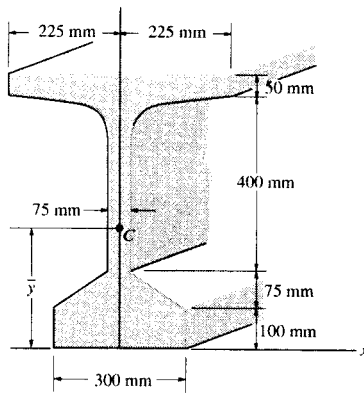

Centroid: The area of each segment and its respective centroid are tabulated below.

| Segment | $A(\text{mm}^2)$ | $\bar{y}(\text{mm})$ | $\bar{y}A(\text{mm}^3)$ |
|----------|------------------------|----------------------|-------------------------|
| 1 | 450(50) | 600 | 13 500 000 |
| 2 | 475(75) | 337.5 | 12 023 437.5 |
| 3 | $\frac{1}{2}(225)(75)$ | 125 | 1 054 687.5 |
| 4 | 300(100) | 50 | 1 500 000 |
| Σ | 96 562.5 | | 28 078 125 |

Thus,

$$\bar{y} = \frac{\Sigma \bar{y}A}{\Sigma A} = \frac{28 078 125}{96 562.5} = 290.78 \text{ mm} = 291 \text{ mm} \quad \text{Ans}$$

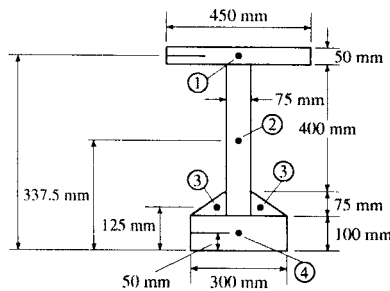

9-69. Determine the distance h to which a 100-mm diameter hole must be bored into the base of the cone so that the center of mass of the resulting shape is located at $\bar{z} = 115$ mm. The material has a density of 8 Mg/m^3 .

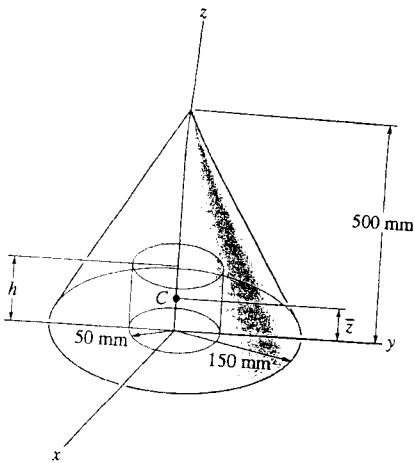

$$\frac{\frac{1}{3}\pi(0.15)^2(0.5)\left(\frac{0.5}{4}\right) - \pi(0.05)^2(h)\left(\frac{h}{2}\right)}{\frac{1}{3}\pi(0.15)^2(0.5) - \pi(0.05)^2(h)} = 0.115$$

$$0.4313 - 0.2875h = 0.4688 - 1.25h^2$$

$$h^2 - 0.230h - 0.0300 = 0$$

Choosing the positive root,

$$h = 323 \text{ mm} \quad \text{Ans}$$

9-70. Determine the distance \bar{z} to the centroid of the shape which consists of a cone with a hole of height $h = 50$ mm bored into its base.

$$\begin{aligned} \Sigma \bar{z}V &= \frac{1}{3}\pi(0.15)^2(0.5)\left(\frac{0.5}{4}\right) - \pi(0.05)^2(0.05)\left(\frac{0.05}{2}\right) \\ &= 1.463(10^{-3}) \text{ m}^4 \end{aligned}$$

$$\begin{aligned} \Sigma V &= \frac{1}{3}\pi(0.15)^2(0.5) - \pi(0.05)^2(0.05) \\ &= 0.01139 \text{ m}^3 \end{aligned}$$

$$\bar{z} = \frac{\Sigma \bar{z}V}{\Sigma V} = \frac{1.463(10^{-3})}{0.01139} = 0.12845 \text{ m} = 128 \text{ mm} \quad \text{Ans}$$

9-71. The sheet metal part has the dimensions shown. Determine the location $(\bar{x}, \bar{y}, \bar{z})$ of its centroid.

$$\Sigma A = 4(3) + \frac{1}{2}(3)(6) = 21 \text{ in}^2$$

$$\Sigma \bar{z}A = -2(4)(3) + 0\left(\frac{1}{2}\right)(3)(6) = -24 \text{ in}^3$$

$$\Sigma \bar{y}A = 1.5(4)(3) + \frac{2}{3}(3)\left(\frac{1}{2}\right)(3)(6) = 36 \text{ in}^3$$

$$\Sigma \bar{x}A = 0(4)(3) - \frac{1}{3}(6)\left(\frac{1}{2}\right)(3)(6) = -18 \text{ in}^3$$

$$\bar{z} = \frac{\Sigma \bar{z}A}{\Sigma A} = \frac{-24}{21} = -1.14 \text{ in.} \quad \text{Ans}$$

$$\bar{y} = \frac{\Sigma \bar{y}A}{\Sigma A} = \frac{36}{21} = 1.71 \text{ in.} \quad \text{Ans}$$

$$\bar{x} = \frac{\Sigma \bar{x}A}{\Sigma A} = \frac{-18}{21} = -0.857 \text{ in.} \quad \text{Ans}$$

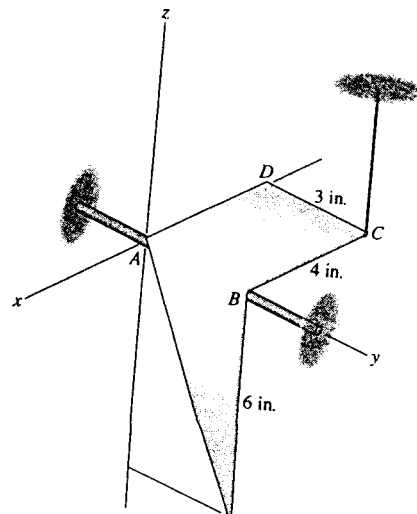

*9-72. The sheet metal part has a weight per unit area of 2 lb/ft² and is supported by the smooth rod and at C. If the cord is cut, the part will rotate about the y axis until it reaches equilibrium. Determine the equilibrium angle of tilt, measured downward from the negative x axis, that AD makes with the -x axis.

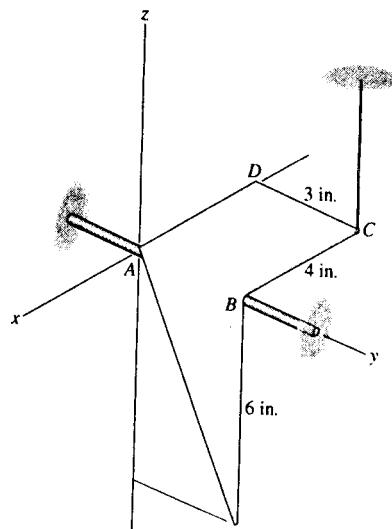

Since the material is homogeneous, the center of gravity coincides with the centroid.

See solution to Prob. 9-71.

$$\theta = \tan^{-1}\left(\frac{1.14}{0.857}\right) = 53.1^\circ \quad \text{Ans}$$

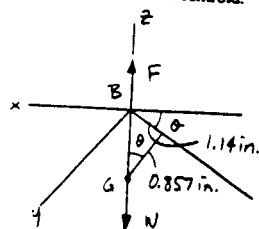

9-73. Determine the location (\bar{x}, \bar{y}) of the centroid C of the cross-sectional area for the structural member constructed from two equal-sized channels welded together as shown. Assume all corners are square. Neglect the size of the welds.

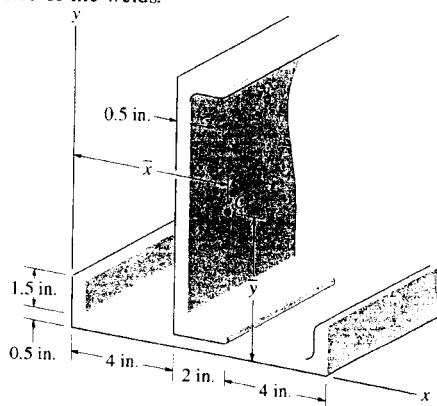

$$\begin{aligned} \Sigma \bar{x}A &= 1.5(0.5)(0.25) + 10(0.5)(5) + 1.5(0.5)(9.75) \\ &\quad + 1.5(0.5)(5.25)(2) + 10(0.5)(4.25) \\ &= 61.625 \text{ in}^3 \end{aligned}$$

$$\Sigma A = [1.5(0.5) + 10(0.5) + 1.5(0.5)](2) = 13 \text{ in}^2$$

$$\bar{x} = \frac{\Sigma \bar{x}A}{\Sigma A} = \frac{61.625}{13} = 4.74 \text{ in.} \quad \text{Ans}$$

$$\begin{aligned} \Sigma \bar{y}A &= 1.5(0.5)(1.25)(2) + 10(0.5)(0.25) + 1.5(0.5)(0.75) \\ &\quad + 10(0.5)(5.5) + 1.5(0.5)(10.25) \\ &= 38.875 \text{ in}^3 \end{aligned}$$

$$\bar{y} = \frac{\Sigma \bar{y}A}{\Sigma A} = \frac{38.875}{13} = 2.99 \text{ in.} \quad \text{Ans}$$

9-74. Determine the location (\bar{x}, \bar{y}) of the center of gravity of the three-wheeler. The location of the center of gravity of each component and its weight are tabulated in the figure. If the three-wheeler is symmetrical with respect to the $x-y$ plane, determine the normal reactions each of its wheels exerts on the ground.

$$\Sigma \bar{x}W = 4.5(18) + 2.3(85) + 3.1(120)$$

$$= 648.5 \text{ lb-ft}$$

$$\Sigma W = 18 + 85 + 120 + 8 = 231 \text{ lb}$$

$$\bar{x} = \frac{\Sigma \bar{x}W}{\Sigma W} = \frac{648.5}{231} = 2.81 \text{ ft} \quad \text{Ans}$$

$$\Sigma \bar{y}W = 1.30(18) + 1.5(85) + 2(120) + 1(8)$$

$$= 398.9 \text{ lb-ft}$$

$$\bar{y} = \frac{\Sigma \bar{y}W}{\Sigma W} = \frac{398.9}{231} = 1.73 \text{ ft} \quad \text{Ans}$$

$$+\Sigma M_A = 0; \quad 2(N_B)(4.5) - 231(2.81) = 0$$

$$N_B = 72.1 \text{ lb} \quad \text{Ans}$$

$$+\uparrow \Sigma F_y = 0; \quad N_A + 2(72.1) - 231 = 0$$

$$N_A = 86.9 \text{ lb} \quad \text{Ans}$$

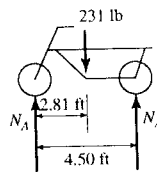
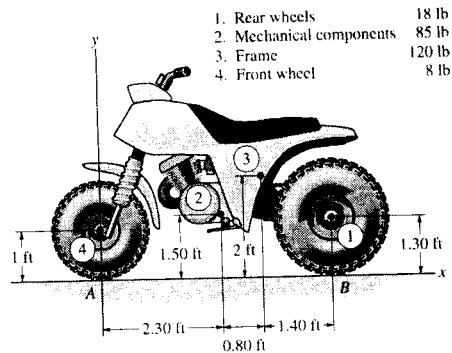

9-75. Major floor loadings in a shop are caused by the weights of the objects shown. Each force acts through its respective center of gravity G . Locate the center of gravity (\bar{x}, \bar{y}) of all these components.

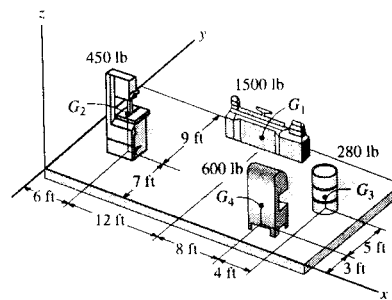

Centroid: The floor loadings on the floor and its respective centroid are tabulated below.

| Loading | W (lb) | \bar{x} (ft) | \bar{y} (ft) | $\bar{x}W$ (lb-ft) | $\bar{y}W$ (lb-ft) |
|----------|----------|----------------|----------------|--------------------|--------------------|
| 1 | 450 | 6 | 9 | 2700 | 3150 |
| 2 | 1500 | 18 | 16 | 27000 | 24000 |
| 3 | 600 | 26 | 3 | 15600 | 1800 |
| 4 | 280 | 8 | 8 | 8400 | 2240 |
| Σ | 2830 | | | 53700 | 31190 |

Thus,

$$\bar{x} = \frac{\Sigma \bar{x}W}{\Sigma W} = \frac{53700}{2830} = 18.98 \text{ ft} = 19.0 \text{ ft} \quad \text{Ans}$$

$$\bar{y} = \frac{\Sigma \bar{y}W}{\Sigma W} = \frac{31190}{2830} = 11.02 \text{ ft} = 11.0 \text{ ft} \quad \text{Ans}$$

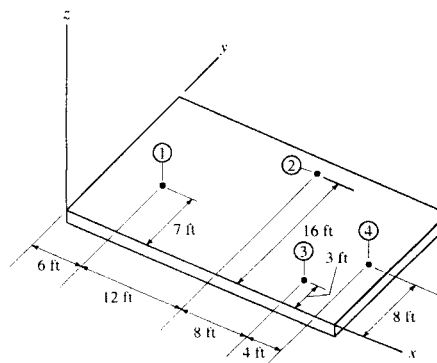

*9-76. Locate the center of gravity of the two-block assembly. The specific weights of the materials A and B are $\gamma_A = 150 \text{ lb/ft}^3$ and $\gamma_B = 400 \text{ lb/ft}^3$, respectively.

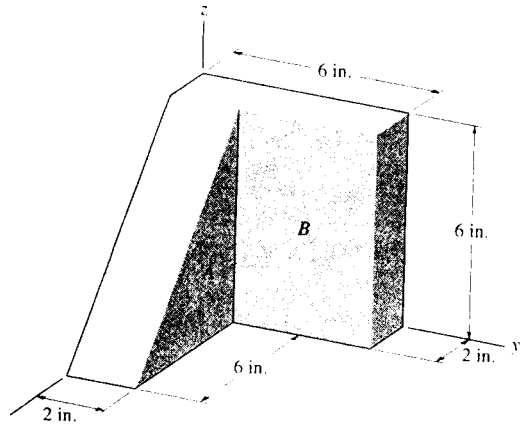

Centroid: The weight of block A and B are $W_A = \frac{1}{2} \left(\frac{6}{12} \right) \left(\frac{6}{12} \right) \left(\frac{2}{12} \right) (150) = 3.125 \text{ lb}$ and $W_B = \left(\frac{6}{12} \right) \left(\frac{6}{12} \right) \left(\frac{2}{12} \right) (400) = 16.67 \text{ lb}$. The weight of each block and its respective centroid are tabulated below.

| Block | W (lb) | \bar{x} (in.) | \bar{y} (in.) | \bar{z} (in.) | $\bar{x}W$ (lb·in) | $\bar{y}W$ (lb·in) | $\bar{z}W$ (lb·in) |
|----------|----------|-----------------|-----------------|-----------------|--------------------|--------------------|--------------------|
| A | 3.125 | 4 | 1 | 2 | 12.5 | 3.125 | 6.25 |
| B | 16.667 | 1 | 3 | 3 | 16.667 | 50.0 | 50.0 |
| Σ | 19.792 | | | | 29.167 | 53.125 | 56.25 |

Thus,

$$\bar{x} = \frac{\Sigma \bar{x}W}{\Sigma W} = \frac{29.167}{19.792} = 1.474 \text{ in.} = 1.47 \text{ in.} \quad \text{Ans}$$

$$\bar{y} = \frac{\Sigma \bar{y}W}{\Sigma W} = \frac{53.125}{19.792} = 2.684 \text{ in.} = 2.68 \text{ in.} \quad \text{Ans}$$

$$\bar{z} = \frac{\Sigma \bar{z}W}{\Sigma W} = \frac{56.25}{19.792} = 2.842 \text{ in.} = 2.84 \text{ in.} \quad \text{Ans}$$

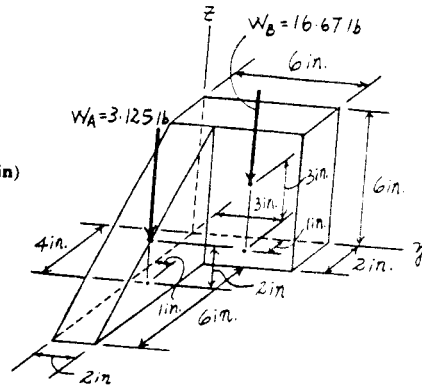

9-77. The buoy is made from two homogeneous cones each having a radius of 1.5 ft. If $h = 1.2 \text{ ft}$, find the distance \bar{z} to the buoy's center of gravity G .

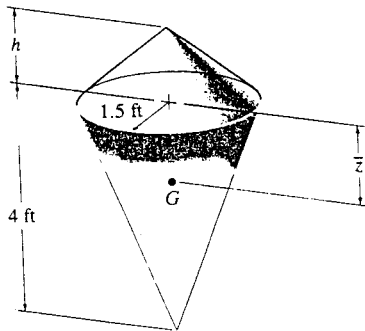

$$\Sigma \bar{z}V = \frac{1}{3} \pi (1.5)^2 (1.2) \left(-\frac{1.2}{4} \right) + \frac{1}{3} \pi (1.5)^2 (4) \left(\frac{4}{4} \right)$$

$$= 8.577 \text{ ft}^4$$

$$\Sigma V = \frac{1}{3} \pi (1.5)^2 (1.2) + \frac{1}{3} \pi (1.5)^2 (4)$$

$$= 12.25 \text{ ft}^3$$

$$\bar{z} = \frac{\Sigma \bar{z}V}{\Sigma V} = \frac{8.577}{12.25} = 0.70 \text{ ft} \quad \text{Ans}$$

9-78. The buoy is made from two homogeneous cones each having a radius of 1.5 ft. If it is required that the buoy's center of gravity G be located at $\bar{z} = 0.5$ ft, determine the height h of the top cone.

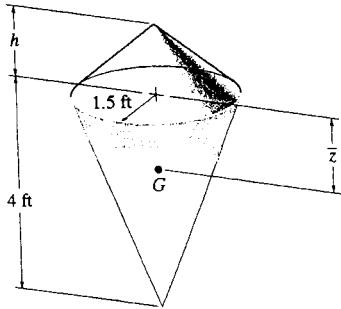

$$\Sigma \bar{z} V = \frac{1}{3} \pi (1.5)^2 (h) \left(\frac{h}{4}\right) + \frac{1}{3} \pi (1.5)^2 (4) \left(\frac{4}{4}\right)$$

$$= -0.5890 h^2 + 9.4248$$

$$\Sigma V = \frac{1}{3} \pi (1.5)^2 (h) + \frac{1}{3} \pi (1.5)^2 (4)$$

$$= 2.3562 h + 9.4248$$

$$\bar{z} = \frac{\Sigma \bar{z} V}{\Sigma V} = \frac{-0.5890 h^2 + 9.4248}{2.3562 h + 9.4248} = 0.5$$

$$-0.5890 h^2 + 9.4248 = 1.1781 h + 4.7124$$

$$h = 2.00 \text{ ft} \quad \text{Ans}$$

9-79. Locate the centroid \bar{z} of the top made from a hemisphere and a cone.

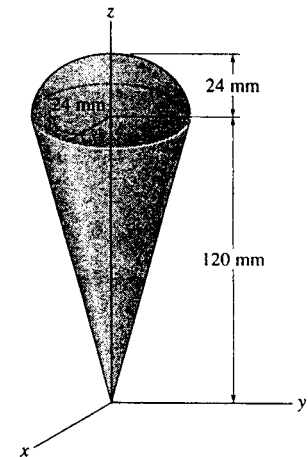

Centroid : The volume of each segment and its respective centroid are tabulated below.

| Segment | $V (\text{mm}^3)$ | $\bar{z} (\text{mm})$ | $\bar{z} V (\text{mm}^4)$ |
|----------|--------------------------------|-----------------------|---------------------------|
| 1 | $\frac{2}{3} \pi (24^3)$ | 129 | $1.188864 \pi (10^6)$ |
| 2 | $\frac{1}{3} \pi (24^2) (120)$ | 90 | $2.0736 \pi (10^6)$ |
| Σ | $32.256 \pi (10^3)$ | | $3.262464 \pi (10^6)$ |

Thus,

$$\bar{z} = \frac{\Sigma \bar{z} V}{\Sigma V} = \frac{3.262464 \pi (10^6)}{32.256 \pi (10^3)} = 101.14 \text{ mm} = 101 \text{ mm} \quad \text{Ans}$$

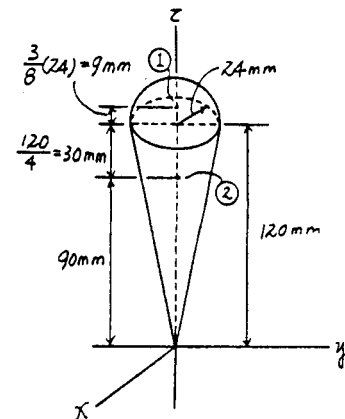

***9-80.** A triangular plate made of homogeneous material has a constant thickness which is very small. If it is folded over as shown, determine the location \bar{y} of the plate's center of gravity G .

$$\Sigma A = \frac{1}{2}(8)(12) = 48 \text{ in}^2$$

$$\Sigma \bar{y}A = 2(1)\left(\frac{1}{2}\right)(1)(3) + 1.5(6)(3) + 2(2)\left(\frac{1}{2}\right)(1)(3)$$

$$= 36 \text{ in}^3$$

$$\bar{y} = \frac{\Sigma \bar{y}A}{\Sigma A} = \frac{36}{48} = 0.75 \text{ in.}$$

Ans

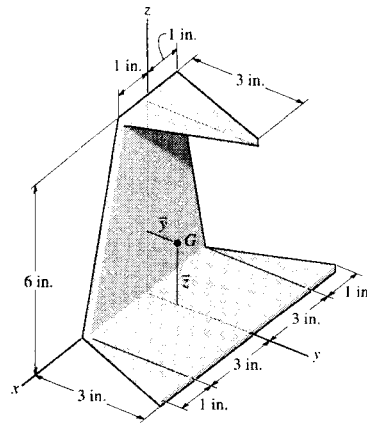

9-81. A triangular plate made of homogeneous material has a constant thickness which is very small. If it is folded over as shown, determine the location \bar{z} of the plate's center of gravity G .

$$\Sigma A = \frac{1}{2}(8)(12) = 48 \text{ in}^2$$

$$\Sigma \bar{z}A = 2(2)\left(\frac{1}{2}\right)(2)(6) + 3(6)(2) + 6\left(\frac{1}{2}\right)(2)(3)$$

$$= 78 \text{ in}^3$$

$$\bar{z} = \frac{\Sigma \bar{z}A}{\Sigma A} = \frac{78}{48} = 1.625 \text{ in.}$$

Ans

9-82. Locate the center of mass \bar{z} of the assembly. The material has a density of $\rho = 3 \text{ Mg/m}^3$. There is a 30-mm diameter hole bored through the center.

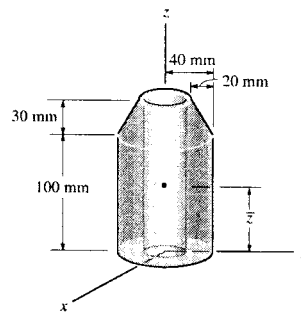

Centroid: Since the density is the same for the whole material, the centroid of the volume coincide with centroid of the mass. The volume of each segment and its respective centroid are tabulated below.

| Segment | $V(\text{mm}^3)$ | $\bar{z}(\text{mm})$ | $\bar{z}V(\text{mm}^4)$ |
|----------|-----------------------------|----------------------|-------------------------|
| 1 | $\frac{1}{3}\pi(40^2)(60)$ | 115 | $3.68\pi(10^6)$ |
| 2 | $\pi(40^2)(100)$ | 50 | $8.00\pi(10^6)$ |
| 3 | $-\frac{1}{3}\pi(20^2)(30)$ | 137.5 | $-0.550\pi(10^6)$ |
| 4 | $-\pi(15^2)(130)$ | 65 | $-1.90125\pi(10^6)$ |
| Σ | $158.75\pi(10^3)$ | | $9.22875\pi(10^6)$ |

Thus,

$$\bar{z} = \frac{\Sigma \bar{z}V}{\Sigma V} = \frac{9.22875\pi(10^6)}{158.75\pi(10^3)} = 58.13 \text{ mm} = 58.1 \text{ mm} \quad \text{Ans}$$

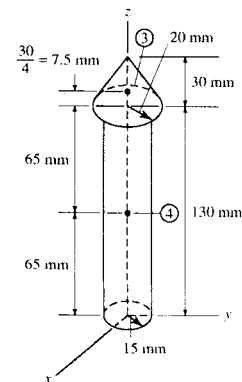
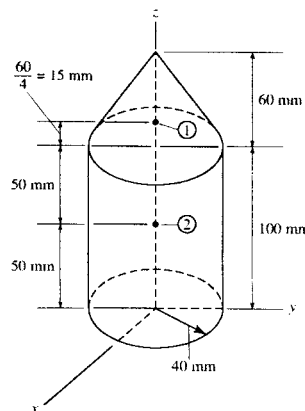

9-83. The assembly consists of a 20-in. wooden dowel rod and a tight-fitting steel collar. Determine the distance \bar{x} to its center of gravity if the specific weights of the materials are $\gamma_w = 150 \text{ lb/ft}^3$ and $\gamma_{st} = 490 \text{ lb/ft}^3$. The radii of the dowel and collar are shown.

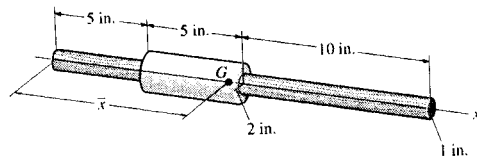

$$\Sigma \bar{x}W = (10\pi(1)^2(20)(150) + 7.5\pi(5)(2^2 - 1^2)(490)) \frac{1}{(12)^3}$$

$$= 154.8 \text{ lb-in.}$$

$$\Sigma W = (\pi(1)^2(20)(150) + \pi(5)(2^2 - 1^2)(490)) \frac{1}{(12)^3}$$

$$= 18.82 \text{ lb}$$

$$\bar{x} = \frac{\Sigma \bar{x}W}{\Sigma W} = \frac{154.8}{18.82} = 8.22 \text{ in.}$$

Ans

9-84. Using integration, determine both the area and the centroidal distance \bar{x} of the shaded area. Then, using the second theorem of Pappus-Guldinus, determine the volume of the solid generated by revolving the area about the y axis.

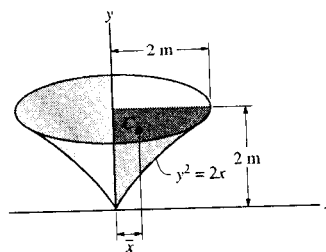

$$\bar{x} = \frac{x}{2}$$

$$\bar{y} = y$$

$$dA = x \, dy$$

$$A = \int dA = \int_0^2 \frac{y^2}{2} dy = \left[\frac{y^3}{6} \right]_0^2 = 1.333 = 1.33 \text{ m}^2 \quad \text{Ans}$$

$$\int \bar{x} dA = \int_0^2 \frac{y^4}{8} dy = \left[\frac{y^5}{40} \right]_0^2 = 0.8 \text{ m}^3$$

$$\bar{x} = \frac{\int \bar{x} dA}{\int dA} = \frac{0.8}{1.333} = 0.6 \text{ m}$$

Ans

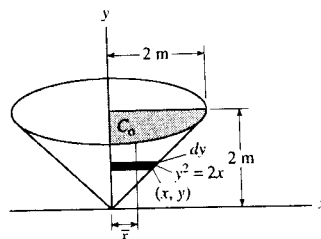

Thus,

$$V = \theta \bar{x} A = 2\pi(0.6)(1.333) = 5.03 \text{ m}^3 \quad \text{Ans}$$

9-85. The anchor ring is made of steel having a specific weight of $\gamma_{st} = 490 \text{ lb/ft}^3$. Determine the surface area of the ring. The cross section is circular as shown.

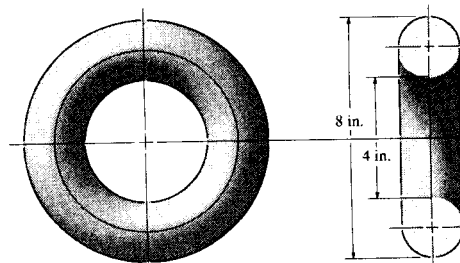

$$A = \theta \bar{r} L = 2\pi(3)2\pi(1)$$

$$= 118 \text{ in}^2$$

Ans

9-86. Using integration, determine both the area and the distance \bar{y} to the centroid of the shaded area. Then using the second theorem of Pappus-Guldinus, determine the volume of the solid generated by revolving the shaded area about the x axis.

Area of the differential element $dA = \left(1 + \frac{y^2}{2}\right) dy$ and $\bar{y} = y$

$$A = \int_A dA = \int_0^2 \left(1 + \frac{y^2}{2}\right) dy = 3.333 \text{ ft}^2 = 3.33 \text{ ft}^2 \quad \text{Ans}$$

$$\int_A \bar{y} dA = \int_0^2 y \left(1 + \frac{y^2}{2}\right) dy = 4 \text{ ft}^3$$

$$\bar{y} = \frac{\int_A \bar{y} dA}{\int_A dA} = \frac{4}{3.333} = 1.2 \text{ ft} \quad \text{Ans}$$

Volume:

$$V = \theta \bar{r} A = 2\pi(1.2)(3.333) = 25.1 \text{ ft}^3 \quad \text{Ans}$$

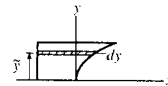
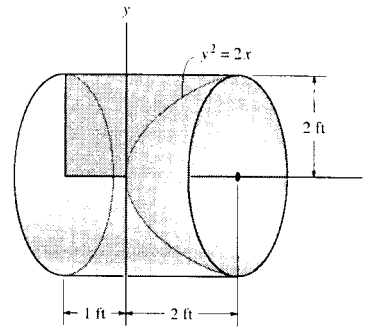

9-87. A steel wheel has a diameter of 840 mm and a cross section as shown in the figure. Determine the total mass of the wheel if $\rho = 5 \text{ Mg/m}^3$

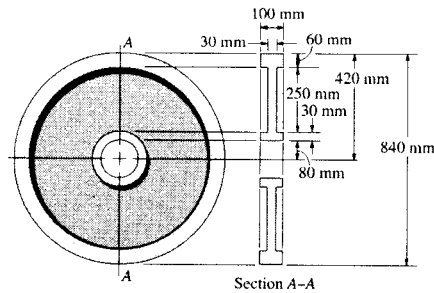

Volume: Applying the theorem of Pappus and Guldinus, Eq. 9-12, with $\theta = 2\pi$, $\bar{r}_1 = 0.095 \text{ m}$, $\bar{r}_2 = 0.235 \text{ m}$, $\bar{r}_3 = 0.39 \text{ m}$, $A_1 = 0.1(0.03) = 0.003 \text{ m}^2$, $A_2 = 0.25(0.03) = 0.0075 \text{ m}^2$ and $A_3 = (0.1)(0.06) = 0.006 \text{ m}^2$, we have

$$V = \theta \Sigma \bar{r} A = 2\pi[0.095(0.003) + 0.235(0.0075) + 0.39(0.006)]$$

$$= 8.775\pi(10^{-3}) \text{ m}^3$$

The mass of the wheel is

$$m = \rho V = 5(10^3)[8.775(10^{-3})\pi]$$

$$= 138 \text{ kg} \quad \text{Ans}$$

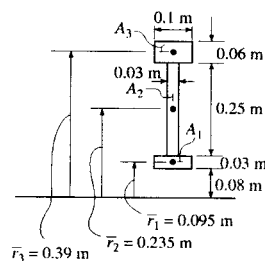

*9-88. The hopper is filled to its top with coal. Determine the volume of coal if the voids (air space) are 25 percent of the volume of the hopper.

Volume: The volume of the hopper can be obtained by applying the theorem of Pappus and Guldinus, Eq. 9-12, with $\theta = 2\pi$, $\bar{r}_1 = 0.75$ m, $\bar{r}_2 = 0.6333$ m, $\bar{r}_3 = 0.1$ m, $A_1 = 1.5(4) = 6.00$ m², $A_2 = \frac{1}{2}(1.3)(1.2) = 0.780$ m² and $A_3 = (0.2)(1.2) = 0.240$ m².

$$V_h = \theta \Sigma \bar{r} A = 2\pi[0.75(6.00) + 0.6333(0.780) + 0.1(0.240)] = 10.036\pi \text{ m}^3$$

The volume of the coal is

$$V_c = 0.65V_h = 0.65(10.036\pi) = 20.5 \text{ m}^3 \quad \text{Ans}$$

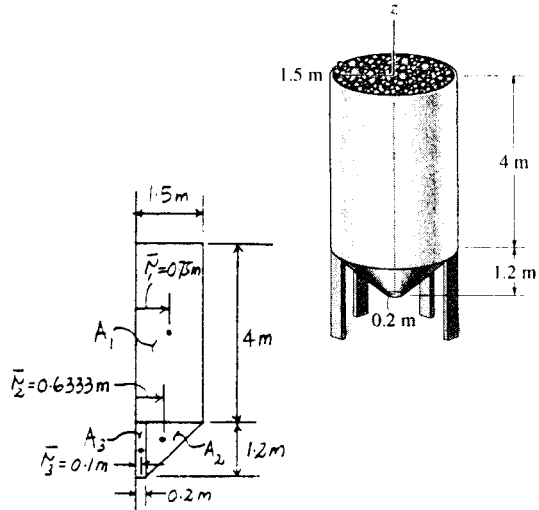

9-89. Sand is piled between two walls as shown. Assume the pile to be a quarter section of a cone and that 26 percent of this volume is voids (air space). Use the second theorem of Pappus-Guldinus to determine the volume of sand.

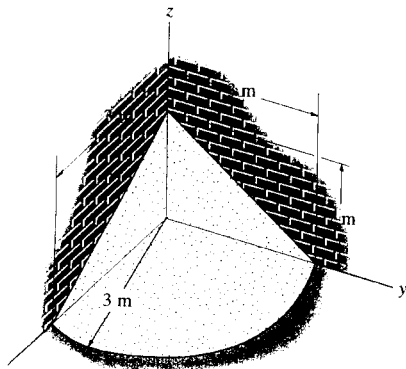

$$V = \theta \bar{r} A = \left[\left(\frac{\pi}{2} \right) (1) \left(\frac{1}{2} \right) (3)(2) \right] (0.74) = 3.49 \text{ m}^3 \quad \text{Ans}$$

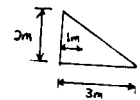

9-90. The rim of a flywheel has the cross section A-A shown. Determine the volume of material needed for its construction.

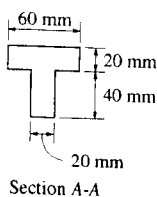
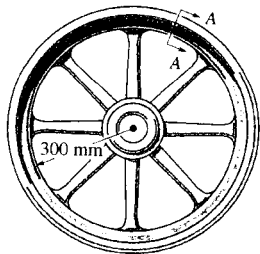

$$V = \Sigma \theta \bar{r} A = 2\pi(350)(60)(20) + 2\pi(320)(40)(20)$$

$$V = 4.25(10^6) \text{ mm}^3 \quad \text{Ans}$$

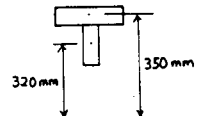

9-91. The open tank is fabricated from a hemisphere and cylindrical shell. Determine the vertical reactions that each of the four symmetrically placed legs exerts on the floor if the tank contains water which is 12 ft deep in the tank. The specific gravity of water is 62.4 lb/ft³. Neglect the weight of the tank.

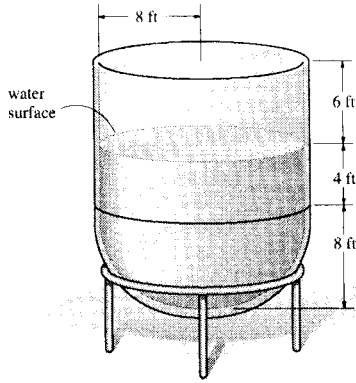

Volume: The volume of the water can be obtained by applying the theorem of Pappus and Guldinus, Eq. 9-12, with $\theta = 2\pi$, $\bar{r}_1 = 4$ ft, $\bar{r}_2 = 3.395$ ft, $A_1 = 8(4) = 32.0$ ft² and $A_2 = \frac{1}{4}\pi(8^2) = 50.27$ ft².

$$V = \theta \Sigma \bar{r} A = 2\pi[4(32.0) + 3.395(50.27)] = 1876.58 \text{ ft}^3$$

The weight of the water is

$$W = \gamma_w V = 62.4(1876.58) = 117098.47 \text{ lb}$$

Thus, the reaction of each leg on the floor is

$$R = \frac{W}{4} = \frac{117098.47}{4} = 29274.62 \text{ lb} = 29.3 \text{ kip} \quad \text{Ans}$$

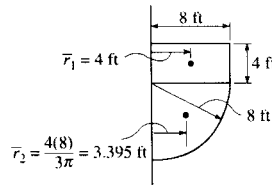

***9-92.** Determine the approximate amount of paint needed to cover the outside surface of the open tank. Assume that a gallon of paint covers 400 ft².

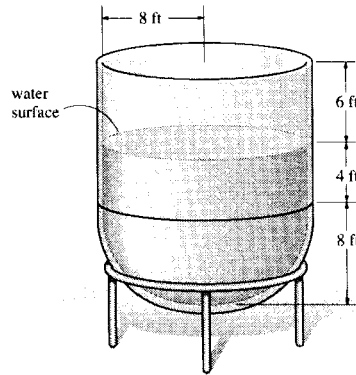

Surface Area: Applying the theorem of Pappus and Guldinus, Eq. 9-11, with $\theta = 2\pi$, $L_1 = 10$ ft, $L_2 = \frac{\pi(8)}{2} = 4\pi$ ft, $\bar{r}_1 = 8$ ft and $\bar{r}_2 = \frac{16}{\pi}$ ft, we have

$$A = \theta \Sigma \bar{r} L = 2\pi \left[8(10) + \frac{16}{\pi}(4\pi) \right] = 288\pi \text{ ft}^2$$

Thus,

$$\text{The required amount paint} = \frac{288\pi}{400} = 2.26 \text{ gallon} \quad \text{Ans}$$

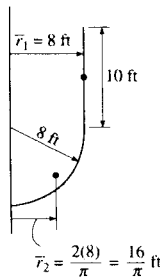

9-93. Determine the volume of material needed to make the casting.

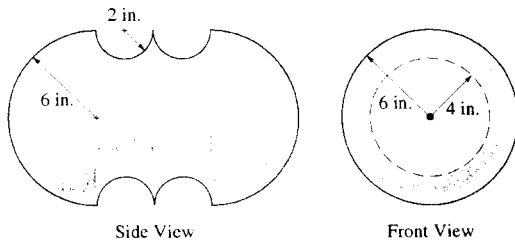

$$\begin{aligned}
 V &= \Sigma \theta A \bar{y} \\
 &= 2\pi \left[2\left(\frac{1}{4}\pi\right)(6)^2\left(\frac{4(6)}{3\pi}\right) + 2(6)(4)(3) - 2\left(\frac{1}{2}\pi\right)(2)^2\left(6 - \frac{4(2)}{3\pi}\right) \right] \\
 &= 1402.8 \text{ in}^3 \\
 V &= 1.40(10^3) \text{ in}^3 \quad \text{Ans}
 \end{aligned}$$

9-94. A circular sea wall is made of concrete. Determine the total weight of the wall if the concrete has a specific weight of $\gamma_c = 150 \text{ lb/ft}^3$.

$$\begin{aligned}
 V &= \Sigma \theta \bar{r} A = \left(\frac{50^\circ}{180^\circ}\right)\pi \left[\left(60 + \frac{2}{3}(7)\right)\left(\frac{1}{2}\right)(30)(7) + 71(30)(8) \right] \\
 &= 20795.6 \text{ ft}^3 \\
 W &= \gamma V = 150(20795.6) = 3.12(10^6) \text{ lb} \quad \text{Ans}
 \end{aligned}$$

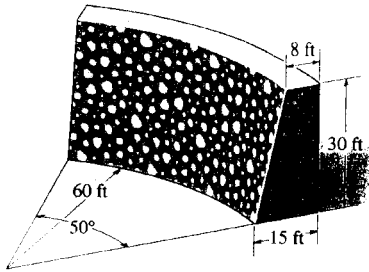
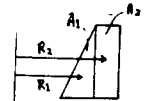

9-95. Determine the outside surface area of the storage tank.

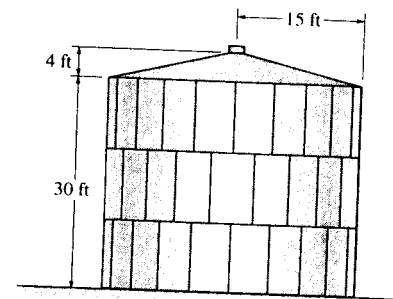

Surface Area: Applying the theorem of Pappus and Guldinus, Eq. 9-11, with $\theta = 2\pi$, $L_1 = \sqrt{15^2 + 4^2} = \sqrt{241} \text{ ft}$, $L_2 = 30 \text{ ft}$, $\bar{r}_1 = 7.5 \text{ ft}$ and $\bar{r}_2 = 15 \text{ ft}$, we have

$$A = \theta \Sigma \bar{r} L = 2\pi [7.5(\sqrt{241}) + 15(30)] = 3.56(10^3) \text{ ft}^2 \quad \text{Ans}$$

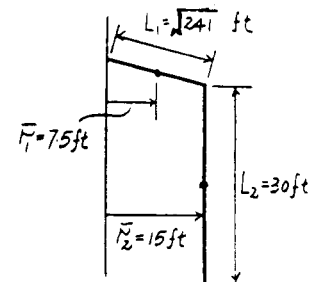

***9-96.** Determine the volume of the storage tank.

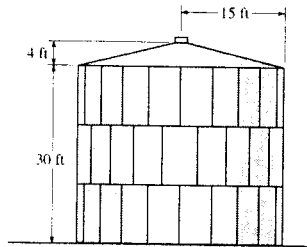

Volume: Applying the theorem of Pappus and Guldinus, Eq. 9-12, with $\theta = 2\pi$, $\bar{r}_1 = 5$ ft, $\bar{r}_2 = 7.5$ ft, $A_1 = \frac{1}{2}(15)(4) = 30.0$ ft² and $A_2 = 30(15) = 450$ ft², we have

$$V = \theta \Sigma \bar{r} A = 2\pi [5(30.0) + 7.5(450)] = 22.1(10^3) \text{ ft}^3 \quad \text{Ans}$$

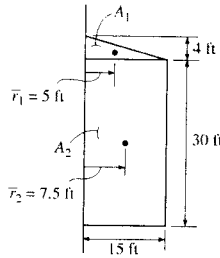

9-97. The water-supply tank has a hemispherical bottom and cylindrical sides. Determine the weight of water in the tank when it is filled to the top at C. Take $\gamma_w = 62.4$ lb/ft³.

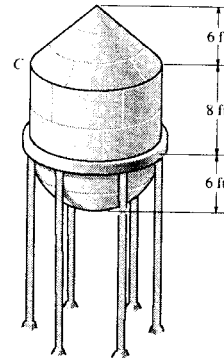

$$V = \Sigma \theta \bar{r} A = 2\pi \left\{ 3(8)(6) + \frac{4(6)}{3\pi} \left(\frac{1}{4} \right) (\pi)(6)^2 \right\}$$

$$V = 1357.17 \text{ ft}^3$$

$$W = \gamma V = 62.4(1357.17) = 84.7 \text{ kip} \quad \text{Ans}$$

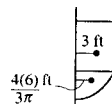

9-98. Determine the number of gallons of paint needed to paint the outside surface of the water-supply tank, which consists of a hemispherical bottom, cylindrical sides, and conical top. Each gallon of paint can cover 250 ft².

$$A = \Sigma \theta \bar{r} L = 2\pi \left\{ 3(6\sqrt{2}) + 6(8) + \frac{2(6)}{\pi} \left(\frac{2(6)\pi}{4} \right) \right\}$$

$$= 687.73 \text{ ft}^2$$

$$\text{Number of gal.} = \frac{687.73 \text{ ft}^2}{250 \text{ ft}^2/\text{gal.}} = 2.75 \text{ gal.} \quad \text{Ans}$$

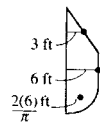

9-99. The process tank is used to store liquids during manufacturing. Estimate both the volume of the tank and its surface area. The tank has a flat top and the plates from which the tank is made have negligible thickness.

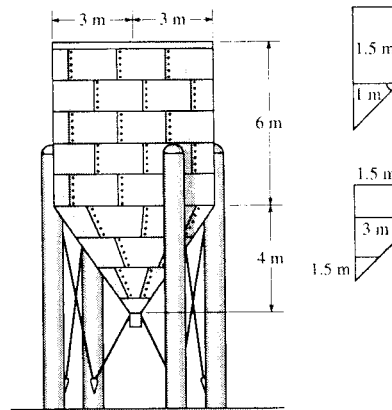

$$V = \Sigma \theta \bar{r} A = 2\pi \left[1 \left(\frac{1}{2} \right) (3)(4) + 1.5(3)(6) \right]$$

$$V = 207.3 \text{ m}^3 = 207 \text{ m}^3 \quad \text{Ans}$$

$$A = \Sigma \theta \bar{r} L = 2\pi [1.5(5) + 3(6) + 1.5(3)]$$

$$= 188 \text{ m}^2 \quad \text{Ans}$$

***9-100.** Determine the height h to which liquid should be poured into the cup so that it contacts half the surface area on the inside of the cup. Neglect the cup's thickness for the calculation.

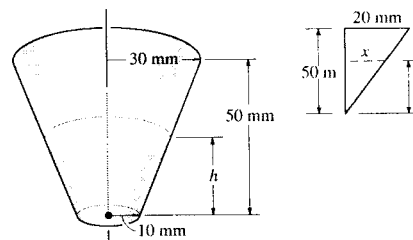

$$A = \theta \bar{r} L = 2\pi (20\sqrt{(20)^2 + (50)^2} + 5(10))$$

$$= 2\pi (1127.03) \text{ mm}^2$$

$$x = \frac{20h}{50} = \frac{2h}{5}$$

$$2\pi \left[5(10) + \left(10 + \frac{h}{5} \right) \sqrt{\left(\frac{2h}{5} \right)^2 + h^2} \right] = \frac{1}{2} (2\pi)(1127.03)$$

$$10.77h + 0.2154h^2 = 513.5$$

$$h = 29.9 \text{ mm} \quad \text{Ans}$$

9-101. A V-belt has an inner radius of 6 in., and a cross-sectional area as shown. Determine the volume of material used in making the V-belt.

Volume: Applying the theorem of Pappus and Guldinus, Eq. 9-12, with $\theta = 2\pi$, $\bar{r}_1 = 6.4665$ in., $\bar{r}_2 = 6.6220$ in., $A_1 = 0.5(0.9330) = 0.4665$ in² and $A_2 = \frac{1}{2}(0.5)(0.9330) = 0.2333$ in², we have

$$V = \theta \Sigma \bar{r} A = 2\pi [6.4665(0.4665) + 6.6220(0.2333)]$$

$$= 28.7 \text{ in}^3 \quad \text{Ans}$$

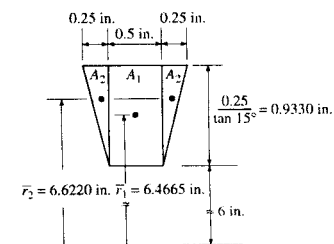
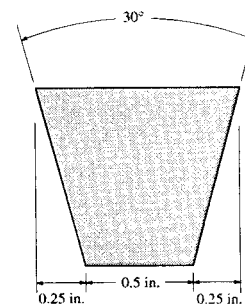

9-102. The full circular aluminum housing is used in an automotive brake system. The cross section is shown in the figure. Determine its weight if aluminum has a specific weight of 169 lb/ft³.

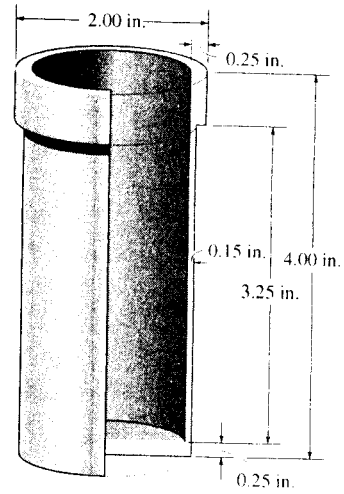

Volume: Applying the theorem of Pappus and Guldinus, Eq. 9-12, with $\theta = 2\pi$, $\bar{r}_1 = 0.875$ in., $\bar{r}_2 = 0.825$ in., $\bar{r}_3 = 0.45$ in., $A_1 = 0.25(0.5) = 0.125$ in², $A_2 = 0.15(3.25) = 0.4875$ in² and $A_3 = 0.25(0.9) = 0.225$ in², we have

$$V = \theta \sum \bar{r} A = 2\pi [0.875(0.125) + 0.825(0.4875) + 0.45(0.225)] = 3.850 \text{ in}^3$$

The weight of the housing is

$$W = \gamma V = 169 \left(\frac{3.850}{12^3} \right) = 0.377 \text{ lb} \quad \text{Ans}$$

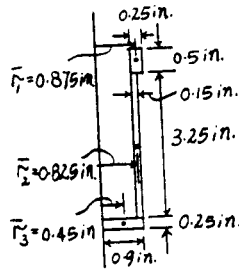

9-103. Determine the height h to which liquid should be poured into the conical cup so that it contacts half the surface area on the inside of the cup.

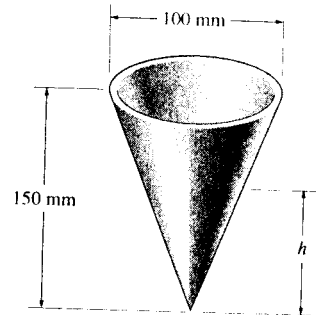

Surface Area: This problem requires that $\frac{1}{2}A_1 = A_2$. Applying the theorem of Pappus and Guldinus, Eq. 9-9, with $\theta = 2\pi$, $L_1 = \sqrt{50^2 + 150^2} = 158.11$ mm, $L_2 = \sqrt{h^2 + \left(\frac{h}{3}\right)^2} = \frac{\sqrt{10}}{3}h$, $\bar{r}_1 = 25$ mm and $\bar{r}_2 = \frac{h}{6}$, we have

$$\frac{1}{2}(\theta \bar{r}_1 L_1) = \theta \bar{r}_2 L_2$$

$$\frac{1}{2} [2\pi(25)(158.11)] = 2\pi \left(\frac{h}{6} \right) \left(\frac{\sqrt{10}}{3} h \right)$$

$$h = 106 \text{ mm} \quad \text{Ans}$$

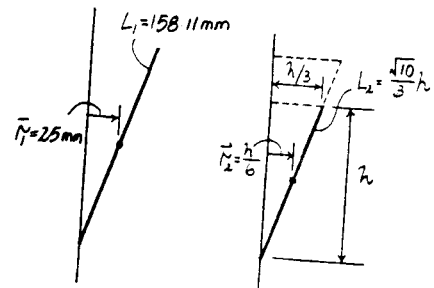

***9-104.** Determine the surface area of the roof of the structure if it is formed by rotating the parabola about the y axis.

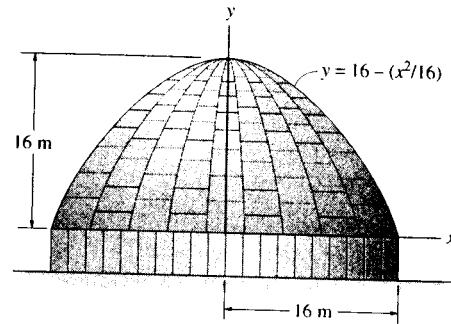

Centroid : The length of the differential element is $dL = \sqrt{dx^2 + dy^2}$
 $= \sqrt{1 + \left(\frac{dy}{dx}\right)^2} dx$ and its centroid is $\bar{x} = x$. Here, $\frac{dy}{dx} = -\frac{x}{8}$. Evaluating the integrals, we have

$$L = \int dL = \int_0^{16\text{m}} \left(\sqrt{1 + \frac{x^2}{64}} \right) dx = 23.663 \text{ m}$$

$$\int_L \bar{x} dL = \int_0^{16\text{m}} x \left(\sqrt{1 + \frac{x^2}{64}} \right) dx = 217.181 \text{ m}^2$$

Applying Eq. 9-7, we have

$$\bar{x} = \frac{\int_L \bar{x} dL}{\int_L dL} = \frac{217.181}{23.663} = 9.178 \text{ m}$$

Surface Area : Applying the theorem of Pappus and Guldinus, Eq. 9-9, with $\theta = 2\pi$, $L = 23.663 \text{ m}$, $\bar{r} = \bar{x} = 9.178$, we have

$$A = \theta \bar{r} L = 2\pi(9.178)(23.663) = 1365 \text{ m}^2 \quad \text{Ans}$$

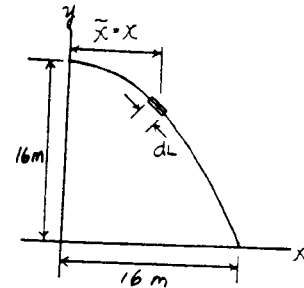

9-105. Determine the interior surface area of the brake piston. It consists of a full circular part. Its cross section is shown in the figure.

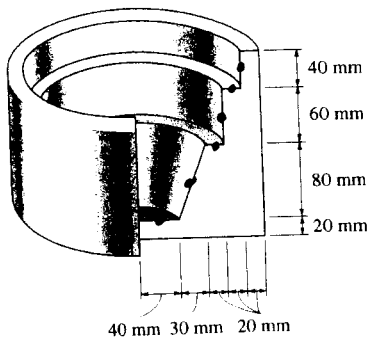

$$A = \Sigma \theta \bar{r} L = 2\pi [20(40) + 55\sqrt{(30)^2 + (80)^2} + 80(20) + 90(60) + 100(20) + 110(40)]$$

$$A = 119(10^3) \text{ mm}^2 \quad \text{Ans}$$

9-106. Determine the magnitude of the resultant hydrostatic force acting on the dam and its location, measured from the top surface of the water. The width of the dam is 8 m; $\rho_w = 1.0 \text{ Mg/m}^3$.

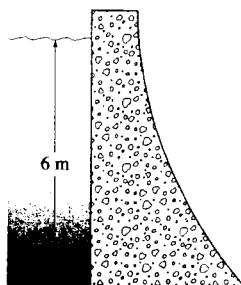

$$p = \rho(1)(10^3)(9.81) = 58\,860 \text{ N/m}^2$$

$$F = \frac{1}{2}(6)(8)(58\,860) = 1.41(10^6) \text{ N} = 1.41 \text{ MN} \quad \text{Ans}$$

$$h = \frac{2}{3}(6) = 4 \text{ m} \quad \text{Ans}$$

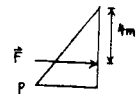

9-107. The tank is filled with water to a depth of $d = 4$ m. Determine the resultant force the water exerts on side A and side B of the tank. If oil instead of water is placed in the tank, to what depth d should it reach so that it creates the same resultant forces? $\rho_o = 900 \text{ kg/m}^3$ and $\rho_w = 1000 \text{ kg/m}^3$.

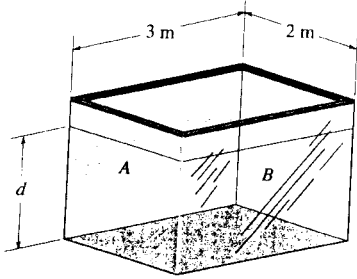

For water

At side A :

$$\begin{aligned} W_A &= b \rho_w g d \\ &= 2(1000)(9.81)(4) \\ &= 78\,480 \text{ N/m} \end{aligned}$$



$$F_{R_A} = \frac{1}{2}(78\,480)(4) = 156\,960 \text{ N} = 157 \text{ kN} \quad \text{Ans}$$

At side B :

$$\begin{aligned} W_B &= b \rho_w g d \\ &= 3(1000)(9.81)(4) \\ &= 117\,720 \text{ N/m} \end{aligned}$$



$$F_{R_B} = \frac{1}{2}(117\,720)(4) = 235\,440 \text{ N} = 235 \text{ kN} \quad \text{Ans}$$

For oil

At side A :

$$\begin{aligned} W_A &= b \rho_o g d \\ &= 2(900)(9.81)d \\ &= 17\,658 d \end{aligned}$$

$$F_{R_A} = \frac{1}{2}(17\,658 d)(d) = 156\,960 \text{ N}$$

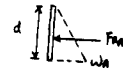

$$d = 4.22 \text{ m} \quad \text{Ans}$$

*9-108. When the tide water A subsides, the tide gate automatically swings open to drain the marsh B . For the condition of high tide shown, determine the horizontal reactions developed at the hinge C and stop block D . The length of the gate is 6 m and its height is 4 m. $\rho_w = 1.0 \text{ Mg/m}^3$.

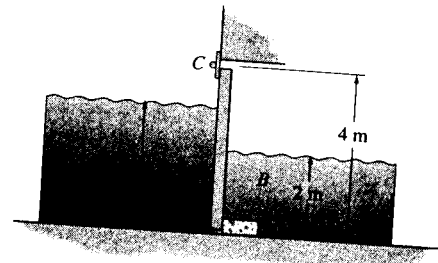

Fluid Pressure : The fluid pressure at points D and E can be determined using Eq. 9-15, $p = \rho g z$.

$$p_D = 1.0(10^3)(9.81)(2) = 19\,620 \text{ N/m}^2 = 19.62 \text{ kN/m}^2$$

$$p_E = 1.0(10^3)(9.81)(3) = 29\,430 \text{ N/m}^2 = 29.43 \text{ kN/m}^2$$

Thus,

$$w_D = 19.62(6) = 117.72 \text{ kN/m}$$

$$w_E = 29.43(6) = 176.58 \text{ kN/m}$$

Resultant Forces :

$$F_{R_1} = \frac{1}{2}(176.58)(3) = 264.87 \text{ kN}$$

$$F_{R_2} = \frac{1}{2}(117.72)(2) = 117.72 \text{ kN}$$

Equations of Equilibrium :

$$+\Sigma M_C = 0; \quad 264.87(3) - 117.72(3.333) - D_x(4) = 0$$

$$D_x = 100.55 \text{ kN} = 101 \text{ kN} \quad \text{Ans}$$

$$\rightarrow \Sigma F_x = 0; \quad 264.87 - 117.72 - 100.55 - C_x = 0$$

$$C_x = 46.6 \text{ kN} \quad \text{Ans}$$

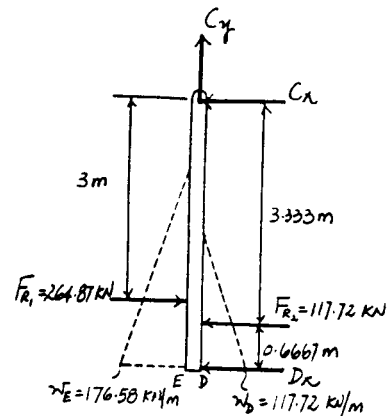

9-109. The concrete "gravity" dam is held in place by its own weight. If the density of concrete is $\rho_c = 2.5 \text{ Mg/m}^3$, and water has a density of $\rho_w = 1.0 \text{ Mg/m}^3$, determine the smallest dimension d that will prevent the dam from overturning about its end A .

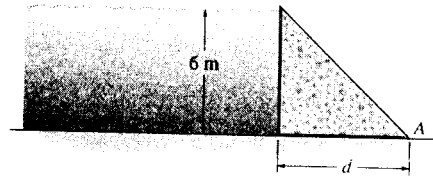

Consider a 1-m width of dam.

$$w = 1000(9.81)(6)(1) = 58\,860 \text{ N/m}$$

$$F = \frac{1}{2}(58\,860)(6)(1) = 176\,580 \text{ N}$$

$$W = \frac{1}{2}(d)(6)(1)(2500)(9.81) = 73\,575d \text{ N}$$

$$(+\Sigma M_A = 0: \quad -176\,580(2) + 73\,575d\left(\frac{2}{3}d\right) = 0$$

$$d = 2.68 \text{ m} \quad \text{Ans}$$

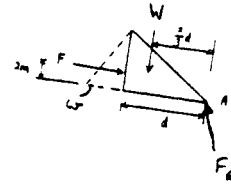

9-110. The concrete dam is designed so that its face AB has a gradual slope into the water as shown. Because of this, the frictional force at the base BD of the dam is increased due to the hydrostatic force of the water acting on the dam. Calculate the hydrostatic force acting on the face AB of the dam. The dam is 60 ft wide. $\gamma_w = 62.4 \text{ lb/ft}^3$.

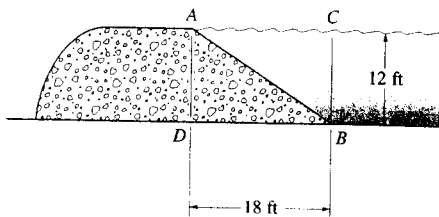

$$F_{AB} = \frac{1}{2}[(62.4)(12)(21.63)](60)$$

$$F_{AB} = 486 \text{ kip} \quad \text{Ans}$$



9-111. The semicircular tunnel passes under a river which is 9 m deep. Determine the vertical resultant hydrostatic force acting per meter of length along the length of the tunnel. The tunnel is 6 m wide; $\rho_w = 1.0 \text{ Mg/m}^3$.

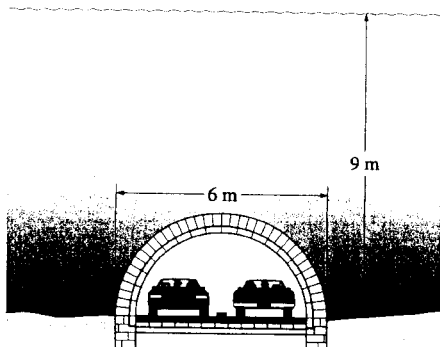

$$F = 9.81(1)(6)(6) + 2(1)(9.81)\left[3(3) - \frac{\pi}{4}(3)^2\right]$$

$$F = 391 \text{ kN/m} \quad \text{Ans}$$

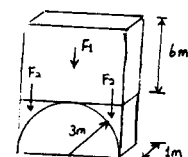

*9-112. The tank is used to store a liquid having a specific weight of 80 lb/ft^3 . If it is filled to the top, determine the magnitude of force the liquid exerts on each of its two sides $ABDC$ and $BDFE$.

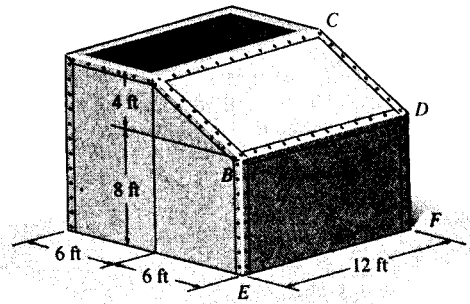

Fluid Pressure : The fluid pressure at points B and E can be determined using Eq. 9-15, $p = \gamma z$.

$$p_B = 80(4) = 320 \text{ lb/ft}^2 \quad p_E = 80(12) = 960 \text{ lb/ft}^2$$

Thus,

$$w_B = 320(12) = 3840 \text{ lb/ft} \quad w_E = 960(12) = 11520 \text{ lb/ft}$$

Resultant Forces : The resultant force acts on surface $ABCD$ is

$$F_{R_1} = \frac{1}{2}(3840)(\sqrt{52}) = 13\,845.31 \text{ lb} = 13.8 \text{ kip} \quad \text{Ans}$$

and acts on surface $BDFE$ is

$$F_{R_2} = \frac{1}{2}(3840 + 11520)(8) = 61\,440 \text{ lb} = 61.4 \text{ kip} \quad \text{Ans}$$

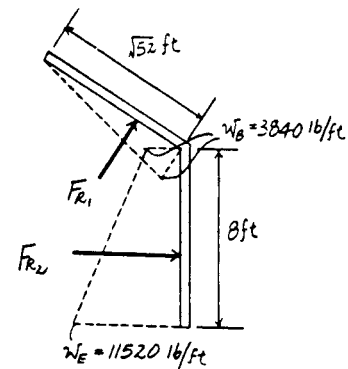

9-113. Determine the resultant horizontal and vertical force components that the water exerts on the side of the dam. The dam is 25 ft long and $\gamma_w = 62.4 \text{ lb/ft}^3$.

Fluid Pressure : The fluid pressure at the toe of the dam can be determined using Eq. 9-15, $p = \gamma z$.

$$p = 62.4(25) = 1560 \text{ lb/ft}^2 = 1.56 \text{ kip/ft}^2$$

Thus,

$$w = 1.56(25) = 39.0 \text{ kip/ft}$$

Resultant Force : From the inside back cover of the text, the area of the semiparabolic area is $A = \frac{2}{3}ab = \frac{2}{3}(10)(25) = 166.67 \text{ ft}^2$. Then, the vertical component of the resultant force is

$$F_{R_v} = \gamma V = 62.4[166.67(25)] = 260\,000 \text{ lb} = 260 \text{ kip} \quad \text{Ans}$$

and the horizontal component of the resultant force is

$$F_{R_h} = \frac{1}{2}(39.0)(25) = 487.5 \text{ kip} \quad \text{Ans}$$

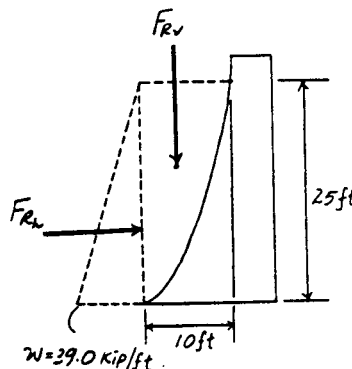
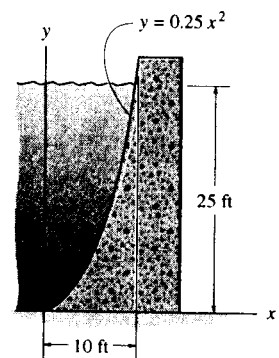

9-114. The gate AB is 8 m wide. Determine the horizontal and vertical components of force acting on the pin at B and the vertical reaction at the smooth support A . $\rho_w = 1.0 \text{ Mg/m}^3$.

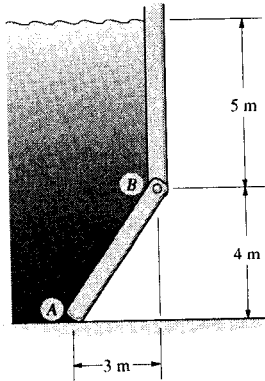

Fluid Pressure: The fluid pressure at points A and B can be determined using Eq. 9-15, $p = \rho g z$.

$$P_A = 1.0(10^3)(9.81)(9) = 88\,290 \text{ N/m}^2 = 88.29 \text{ kN/m}^2$$

$$P_B = 1.0(10^3)(9.81)(5) = 49\,050 \text{ N/m}^2 = 49.05 \text{ kN/m}^2$$

Thus,

$$w_A = 88.29(8) = 706.32 \text{ kN/m}$$

$$w_B = 49.05(8) = 392.40 \text{ kN/m}$$

Resultant Forces:

$$F_{R_1} = 392.4(5) = 1962.0 \text{ kN}$$

$$F_{R_2} = \frac{1}{2}(706.32 - 392.4)(8) = 784.8 \text{ kN}$$

Equations of Equilibrium:

$$+\Sigma M_B = 0: 1962.0(2.5) + 784.8(3.333) - A_y(3) = 0$$

$$A_y = 2507 \text{ kN} = 2.51 \text{ MN} \quad \text{Ans}$$

$$\rightarrow \Sigma F_x = 0: 784.8\left(\frac{4}{5}\right) + 1962\left(\frac{4}{5}\right) - B_x = 0$$

$$B_x = 2197 \text{ kN} = 2.20 \text{ MN} \quad \text{Ans}$$

$$+\uparrow \Sigma F_y = 0: 2507 - 784.8\left(\frac{3}{5}\right) - 1962\left(\frac{3}{5}\right) - B_y = 0$$

$$B_y = 859 \text{ kN} \quad \text{Ans}$$

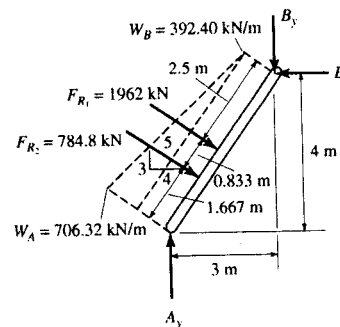

9-115. The storage tank contains oil having a specific weight of $\gamma_o = 56 \text{ lb/ft}^3$. If the tank is 6 ft wide, calculate the resultant force acting on the inclined side BC of the tank, caused by the oil, and specify its location along BC , measured from B . Also compute the total resultant force acting on the bottom of the tank.

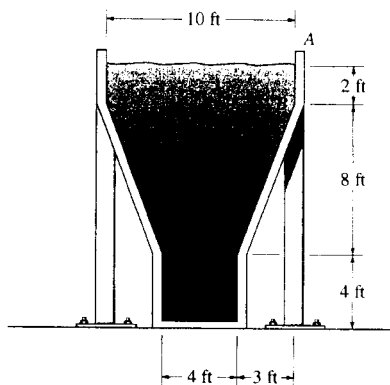

$$W_B = b \rho_o h = 6(56)(2) = 672 \text{ lb/ft}$$

$$W_C = b \rho_o h = 6(56)(10) = 3360 \text{ lb/ft}$$

$$F_{B_1} = 8(672) = 5376 \text{ lb}$$

$$F_{B_2} = \frac{1}{2}(3360 - 672)(8) = 10752 \text{ lb}$$

$$F_{V_1} = 3(2)(6)(56) = 2016 \text{ lb}$$

$$F_{V_2} = \frac{1}{2}(3)(8)(6)(56) = 4032 \text{ lb}$$

$$\rightarrow \Sigma F_{R_x} = \Sigma F_x; \quad F_{R_x} = 5376 + 10752 = 16128 \text{ lb}$$

$$+\downarrow \Sigma F_{R_y} = \Sigma F_y; \quad F_{R_y} = 2016 + 4032 = 6048 \text{ lb}$$

$$F_R = \sqrt{(16128)^2 + (6048)^2} \\ = 17225 \text{ lb} = 17.2 \text{ kip} \quad \text{Ans}$$

$$\theta = \tan^{-1}\left(\frac{6048}{16128}\right) = 20.56^\circ \searrow$$

$$\zeta + \Sigma M_{R_x} = F_R(d);$$

$$17225 d = 10752\left(\frac{2}{3}\right)(8) + 5376(4) + 2016(1.5) + 4032(2)$$

$$d = 5.22 \text{ ft} \quad \text{Ans}$$

At bottom

$$F_R = 4(14)(6)(56) = 18816 \text{ lb} = 18.8 \text{ kip} \quad \text{Ans}$$

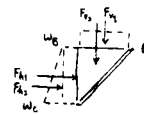

*9-116. The arched surface AB is shaped in the form of a quarter circle. If it is 8 m long, determine the horizontal and vertical components of the resultant force caused by the water acting on the surface. $\rho_w = 1.0 \text{ Mg/m}^3$.

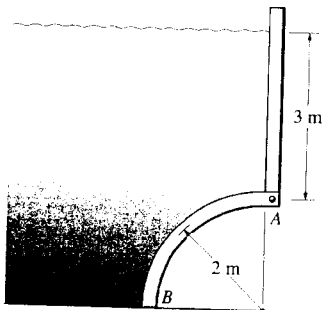

$$F_3 = 1000(9.81)(3)(2)(8) = 470.88 \text{ kN}$$

$$F_2 = 1000(9.81)(3)(2)(8) = 470.88 \text{ kN}$$

$$F_1 = 1000(9.81)(2)\left(\frac{1}{2}\right)(2)(8) = 156.96 \text{ kN}$$

$$W = [(2)^2 - \frac{1}{4}\pi(2)^2](8)(1000)(9.81) = 67.37 \text{ kN}$$

$$F_x = 156.96 + 470.88 = 628 \text{ kN} \quad \text{Ans}$$

$$F_y = 470.88 + 67.37 = 538 \text{ kN} \quad \text{Ans}$$

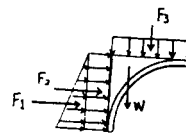

9-117. The rectangular bin is filled with coal, which creates a pressure distribution along wall A that varies as shown, i.e., $p = 4z^3$ lb/ft², where z is measured in feet. Determine the resultant force created by the coal, and specify its location measured from the top surface of the coal.

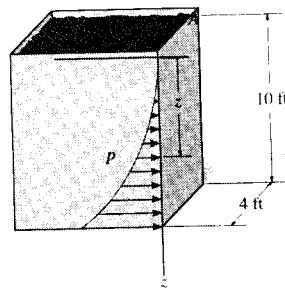

Resultant Force and Its Location: The volume of the differential element is $dV = dF_R = 4pdz = 4(4z^3)dz = 16z^3dz$ and its centroid is at $\bar{z} = z$.

$$F_R = \int_{F_R} dF_R = \int_0^{10 \text{ ft}} 16z^3 dz = 4z^4 \Big|_0^{10 \text{ ft}} = 40\,000 \text{ lb} = 40.0 \text{ kip} \quad \text{Ans}$$

$$\int_{F_R} \bar{z} dF_R = \int_0^{10 \text{ ft}} z(16z^3 dz) = \frac{16}{5} z^5 \Big|_0^{10 \text{ ft}} = 320\,000 \text{ lb}\cdot\text{ft}$$

$$\bar{z} = \frac{\int_{F_R} \bar{z} dF_R}{\int_{F_R} dF_R} = \frac{320\,000}{40\,000} = 8.00 \text{ ft} \quad \text{Ans}$$

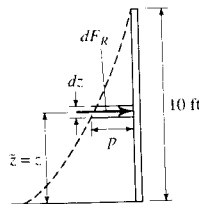

9-118. The semicircular drainage pipe is filled with water. Determine the resultant horizontal and vertical force components that the water exerts on the side AB of the pipe per foot of pipe length; $\gamma_w = 62.4$ lb/ft³.

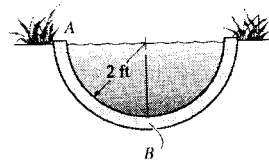

Fluid Pressure: The fluid pressure at the bottom of the drain can be determined using Eq. 9-15, $p = \gamma z$.

$$p = 62.4(2) = 124.8 \text{ lb/ft}^2$$

Thus,

$$w = 124.8(1) = 124.8 \text{ lb/ft}$$

Resultant Forces: The area of the quarter circle is $A = \frac{1}{4}\pi r^2 = \frac{1}{4}\pi(2^2) = \pi \text{ ft}^2$. Then, the vertical component of the resultant force is

$$F_{R_v} = \gamma V = 62.4[\pi(1)] = 196 \text{ lb} \quad \text{Ans}$$

and the horizontal component of the resultant force is

$$F_{R_h} = \frac{1}{2}(124.8)(2) = 125 \text{ lb} \quad \text{Ans}$$

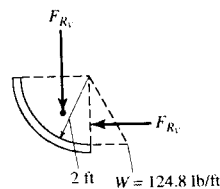

9-119. The pressure loading on the plate is described by the function $p = 10\left[\frac{6}{(x+1)} + 8\right]$ lb/ft². Determine the magnitude of the resultant force and the coordinates (\bar{x}, \bar{y}) of the point where the line of action of the force intersects the plate.

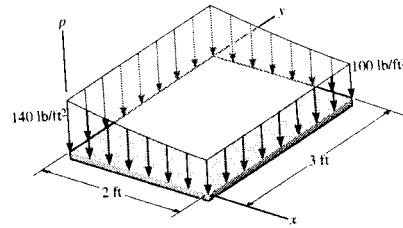

$$p = 10 \left[\frac{6}{(x+1)} + 8 \right]$$

$$F_R = \int_A p \, dA = \int_0^2 10 \left[\frac{6}{(x+1)} + 8 \right] 3 \, dx$$

$$F_R = 30[6 \ln(x+1) + 8x]_0^2 = 677.75 \text{ lb} = 678 \text{ lb} \quad \text{Ans}$$

$$\int_A \bar{x} p \, dA = \int_0^2 x(10) \left[\frac{6}{(x+1)} + 8 \right] 3 \, dx$$

$$= 30[6(x - \ln(1+x)) + 4x^2]_0^2 = 642.250$$

$$\bar{x} = \frac{\int_A \bar{x} p \, dA}{\int_A p \, dA} = \frac{642.250}{677.75} = 0.948 \text{ ft} \quad \text{Ans}$$

$$\bar{y} = 1.50 \text{ ft} \quad (\text{by symmetry}) \quad \text{Ans}$$

9-120. The tank is filled to the top ($y = 0.5$ m) with water having a density of $\rho_w = 1.0$ Mg/m³. Determine the resultant force of the water pressure acting on the flat end plate C of the tank, and its location, measured from the top of the tank.

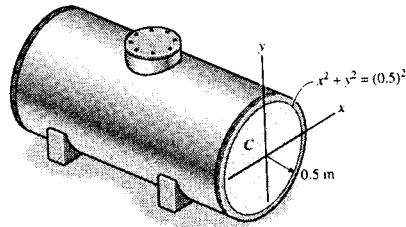

$$dF = p \, dA = (1)(9.81)(0.5 - y) 2x \, dy$$

$$F = 2(9.81) \int_{-0.5}^{0.5} (0.5 - y)(\sqrt{(0.5)^2 - y^2}) \, dy$$

$$= \frac{9.81}{2} \left[y\sqrt{(0.5)^2 - y^2} + 0.5^2 \sin^{-1} \left(\frac{y}{0.5} \right) \right]_{-0.5}^{0.5}$$

$$+ \frac{2(9.81)}{3} \left[\sqrt{(0.5)^2 - y^2} \right]_{-0.5}^{0.5}$$

$$F = 3.85 \text{ kN} \quad \text{Ans}$$

$$\int_A y \, dF = 2(9.81) \int_{-0.5}^{0.5} (0.5y - y^2)(\sqrt{(0.5)^2 - y^2}) \, dy = 19.62 \left\{ \left[-\frac{0.5}{3} \sqrt{(0.5)^2 - y^2} \right]_{-0.5}^{0.5} + \right.$$

$$\left. \frac{y}{4} \left[\sqrt{(0.5)^2 - y^2} \right]_{-0.5}^{0.5} - \frac{(0.5)^2}{8} \left[y\sqrt{(0.5)^2 - y^2} + (0.5)^2 \sin^{-1} \frac{y}{0.5} \right]_{-0.5}^{0.5} \right\}$$

$$= -0.481 \text{ kN m}$$

$$F(-d) = \int y \, dF$$

$$d = \frac{-0.481}{3.85} = -0.125 \text{ m}$$

Hence, measured from the top of the tank,

$$d' = 0.5 + 0.125 = 0.625 \text{ m} \quad \text{Ans}$$

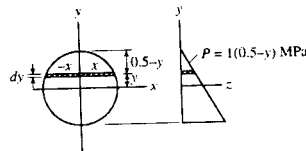

9-121. The wind blows uniformly on the front surface of the metal building with a pressure of 30 lb/ft². Determine the resultant force it exerts on the surface and the position of this resultant.

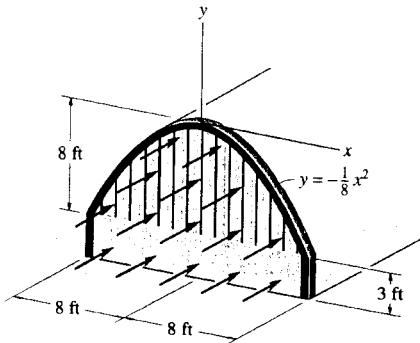

Parabola:

$$F_r = \int_0^8 30(2x \, dy)$$

$$= 60 \int_0^8 \sqrt{8} y^{1/2} \, dy$$

$$= 60\sqrt{8} \left(\frac{2}{3}\right) (8)^{3/2} = 2560 \text{ lb}$$

$$\bar{y} = \frac{\int_0^8 y(30)(2x \, dy)}{2560} = \frac{60 \int_0^8 \sqrt{8} y^{3/2} \, dy}{2560}$$

$$\bar{y} = \frac{60\sqrt{8} \left(\frac{2}{5}\right) (8)^{5/2}}{2560} = 4.80 \text{ ft}$$

Also, from table in back of text:

$$F_r = p \left(\frac{2}{3} ab\right) = 60 \left(\frac{2}{3}\right) (8)(8) = 2560$$

$$\bar{y} = \frac{3}{5}(8) = 4.80 \text{ ft}$$

$$F_R = 2560 + 30(3)(16) = 4000 \text{ lb} = 4.00 \text{ kip} \quad \text{Ans}$$

$$4000(\bar{y}) = 4.80(2560) + 9.5(30)(3)(16)$$

$$\bar{y} = -6.49 \text{ ft} \quad \text{Ans}$$

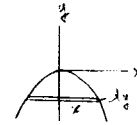

9-122. The loading acting on a square plate is represented by a parabolic pressure distribution. Determine the magnitude of the resultant force and the coordinates (\bar{x}, \bar{y}) of the point where the line of action of the force intersects the plate. Also, what are the reactions at the rollers B and C and the ball-and-socket joint A ? Neglect the weight of the plate.

$$\bar{y} = y$$

$$dA = p \, dy$$

$$\bar{x} = 0 \quad \text{Ans} \quad (\text{Due to symmetry})$$

$$\int dA = \int_0^4 2y^{1/2} dy = \left[\frac{4}{3} y^{3/2} \right]_0^4 = 10.67 \text{ kN/m}$$

$$\int \bar{y} \, dA = \int_0^4 2y^{3/2} dy = \left[\frac{4}{5} y^{5/2} \right]_0^4 = 25.6 \text{ kN}$$

$$\bar{y} = \frac{\int \bar{y} \, dA}{\int dA} = \frac{25.6}{10.67} = 2.40 \text{ m} \quad \text{Ans}$$

$$F_R = 10.67(4) = 42.7 \text{ kN} \quad \text{Ans}$$

$$\Sigma M_y = 0; \quad B_y = C_y$$

$$\Sigma M_x = 0; \quad 42.67(2.40) - 2B_y(4) = 0$$

$$B_y = C_y = 12.8 \text{ kN} \quad \text{Ans}$$

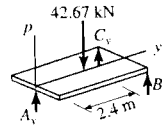
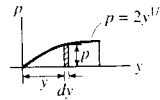
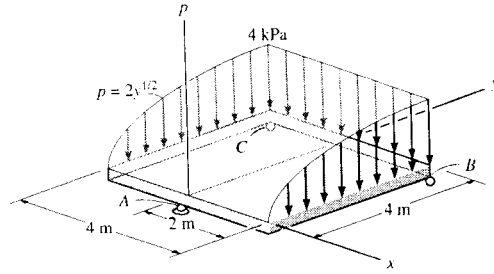

$$+\uparrow \Sigma F = 0; \quad A_y - 42.67 + 12.8 + 12.8 = 0$$

$$A_y = 17.1 \text{ kN} \quad \text{Ans}$$

9-123. The tank is filled with a liquid which has a density of 900 kg/m^3 . Determine the resultant force that it exerts on the elliptical end plate, and the location of the center of pressure, measured from the x axis.

Fluid Pressure: The fluid pressure at an arbitrary point along y axis can be determined using Eq. 9-15, $p = \gamma(0.5 - y) = 900(9.81)(0.5 - y) = 8829(0.5 - y)$.

Resultant Force and its Location: Here, $x = \sqrt{1 - 4y^2}$. The volume of the differential element is $dV = dF_R = p(2x \, dy) = 8829(0.5 - y)[2\sqrt{1 - 4y^2}] \, dy$. Evaluating the integrals using Simpson's rule, we have

$$F_R = \int_{F_R} dF_R = 17658 \int_{-0.5 \text{ m}}^{0.5 \text{ m}} (0.5 - y)(\sqrt{1 - 4y^2}) \, dy = 6934.2 \text{ N} = 6.93 \text{ kN} \quad \text{Ans}$$

$$\int_{F_R} \bar{y} \, dF_R = 17658 \int_{-0.5 \text{ m}}^{0.5 \text{ m}} y(0.5 - y)(\sqrt{1 - 4y^2}) \, dy = -866.7 \text{ N}\cdot\text{m}$$

$$\bar{y} = \frac{\int_{F_R} \bar{y} \, dF_R}{\int_{F_R} dF_R} = \frac{-866.7}{6934.2} = -0.125 \text{ m} \quad \text{Ans}$$

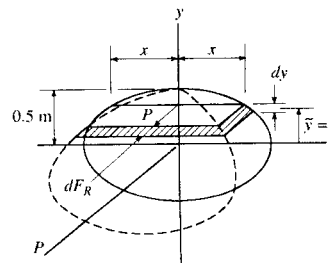
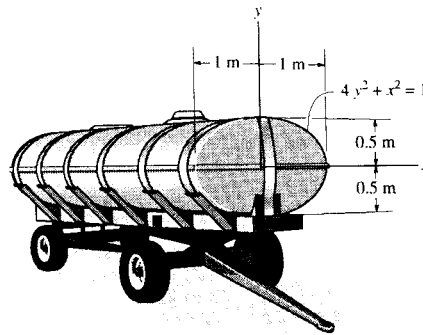

*9-124. A circular V-belt has an inner radius of 600 mm and a cross-sectional area as shown. Determine the volume of material required to make the belt.

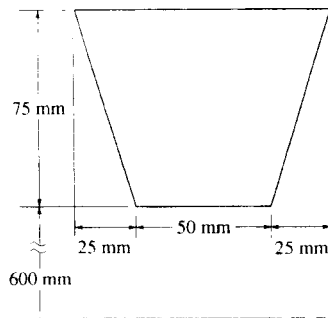

$$V = \Sigma \theta \bar{r} A$$

$$= 2\pi \left[0.625(2) \left(\frac{1}{2} \right) (0.025)(0.075) + 0.6375(0.05)(0.075) \right]$$

$$= 22.4(10)^{-3} \text{ m}^3$$

Ans

9-125. A circular V-belt has an inner radius of 600 mm and a cross-sectional area as shown. Determine the surface area of the belt.

$$A = \Sigma \theta \bar{r} L$$

$$= 2\pi [0.6(0.05) + 2(0.6375)(\sqrt{(0.025)^2 + (0.075)^2}) + 0.675(0.1)]$$

$$= 1.25 \text{ m}^2$$

Ans

9-126. Locate the centroid \bar{y} of the beam's cross-sectional area.

Centroid: The area of each segment and its respective centroid are tabulated below.

| Segment | A (mm ²) | \bar{y} (mm) | $\bar{y}A$ (mm ³) |
|----------|----------------------|----------------|-------------------------------|
| 1 | 300(25) | 112.5 | 843 750 |
| 2 | 100(50) | 50 | 250 000 |
| Σ | 12 500 | | 1 093 750 |

Thus,

$$\bar{y} = \frac{\Sigma \bar{y}A}{\Sigma A} = \frac{1\,093\,750}{12\,500} = 87.5 \text{ mm}$$

Ans

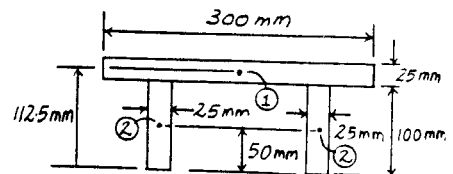
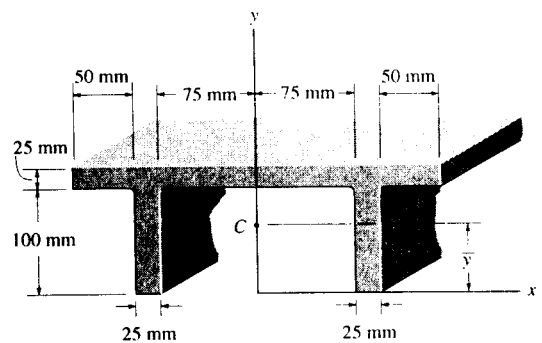

9-127. Locate the centroid of the solid.

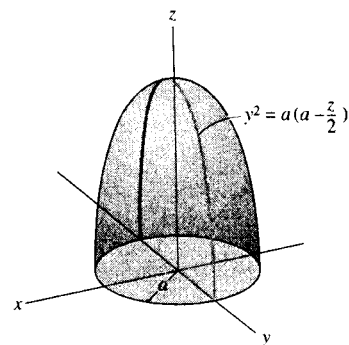

Volume and Moment Arm : The volume of the thin disk differential element is $dV = \pi y^2 dz = \pi \left[a \left(a - \frac{z}{2} \right) \right] dz = \pi a \left(a - \frac{z}{2} \right) dz$ and its centroid is at $\bar{z} = z$.

Centroid : Due to symmetry about the z axis

$$\bar{x} = \bar{y} = 0 \quad \text{Ans}$$

Applying Eq. 9-5 and performing the integration, we have

$$\begin{aligned} \bar{z} &= \frac{\int_V \bar{z} dV}{\int_V dV} = \frac{\int_0^{2a} z \left[\pi a \left(a - \frac{z}{2} \right) dz \right]}{\int_0^{2a} \pi a \left(a - \frac{z}{2} \right) dz} \\ &= \frac{\pi a \left(\frac{az^2}{2} - \frac{z^3}{6} \right) \Big|_0^{2a}}{\pi a \left(az - \frac{z^2}{4} \right) \Big|_0^{2a}} = \frac{2}{3}a \quad \text{Ans} \end{aligned}$$

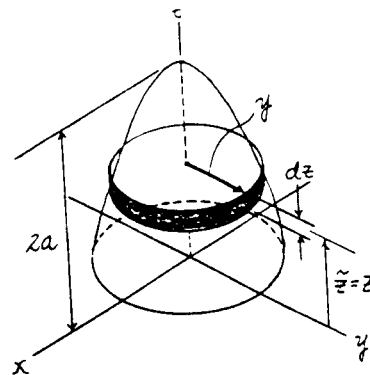

*9-128. Determine the magnitude of the resultant hydrostatic force acting per foot of length on the sea wall; $\gamma_w = 62.4 \text{ lb/ft}^3$.

Fluid Pressure : The fluid pressure at the toe of the dam can be determined using Eq. 9-15, $p = \gamma z$.

$$p = 62.4(8) = 499.2 \text{ lb/ft}^2$$

Thus,

$$w = 499.2(1) = 499.2 \text{ lb/ft}$$

Resultant Forces : From the inside back cover of the text, the parabolic area is $A = \frac{1}{3}ab = \frac{1}{3}(8)(2) = 5.333 \text{ ft}^2$. Then, the vertical and horizontal components of the resultant force are

$$F_R = \gamma V = 62.4[5.333(1)] = 332.8 \text{ lb}$$

$$F_{R_h} = \frac{1}{2}(499.2)(8) = 1996.8 \text{ lb}$$

The resultant force and is

$$\begin{aligned} F_R &= \sqrt{F_{R_h}^2 + F_R^2} = \sqrt{332.8^2 + 1996.8^2} \\ &= 2024.34 \text{ lb} = 2.02 \text{ kip} \quad \text{Ans} \end{aligned}$$

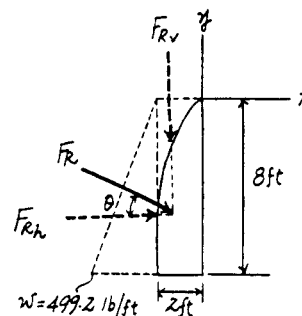
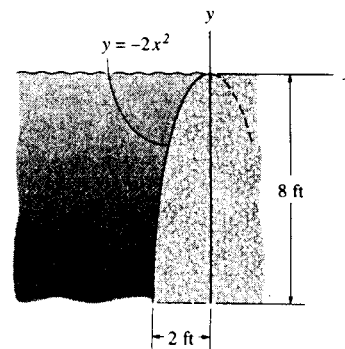

9-129. The tank and compressor have a mass of 15 kg and mass center at G_T and the motor has a mass of 70 kg and a mass center at G_M . Determine the angle of tilt, θ of the tank so that the unit will be on the verge of tipping over.

$$\bar{x} = \frac{\Sigma \bar{x}W}{\Sigma W} = \frac{0.2(15) + 0.5(70)}{15 + 70} = 0.4471 \text{ m}$$

$$\bar{y} = \frac{\Sigma \bar{y}W}{\Sigma W} = \frac{0.35(15) + 0.625(70)}{15 + 70} = 0.57647 \text{ m}$$

$$\theta = \tan^{-1}\left(\frac{\bar{x}}{\bar{y}}\right) = \frac{0.4471}{0.57647} = 37.8^\circ \quad \text{Ans}$$

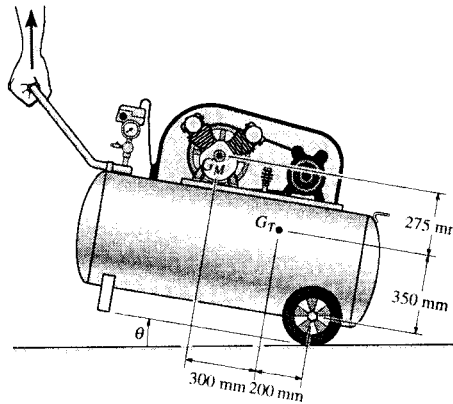
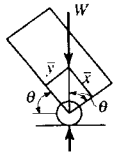

9-130. The thin-walled channel and stiffener have the cross section shown. If the material has a constant thickness, determine the location \bar{y} of its centroid. The dimensions are indicated to the center of each segment.

$$\bar{y} = \frac{\Sigma \bar{y}L}{\Sigma L} = \frac{(0)(9) + 2(1)(2) + 2(2)(1) + 2(0.5)(1) + 1(3)}{(9) + 2(2) + 2(1) + 2(1) + 3}$$

$$\bar{y} = 0.600 \text{ in.} \quad \text{Ans}$$

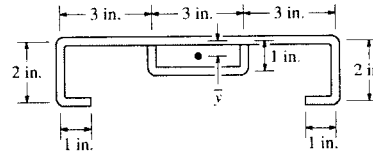

9-131. Locate the center of gravity of the homogeneous rod. The rod has a weight of 2 lb/ft. Also, compute the x , y , z components of reaction at the fixed support A.

$$\Sigma \bar{x}L = 0(4) + 2(\pi)(2) = 12.5664 \text{ ft}^2$$

$$\Sigma \bar{y}L = 0(4) + \frac{2(2)}{\pi}(\pi)(2) = 8 \text{ ft}^2$$

$$\Sigma \bar{z}L = 2(4) + 0(\pi)(2) = 8 \text{ ft}^2$$

$$\Sigma L = 4 + \pi(2) = 10.2832 \text{ ft}$$

$$\bar{x} = \frac{\Sigma \bar{x}L}{\Sigma L} = \frac{12.5664}{10.2832} = 1.22 \text{ ft} \quad \text{Ans}$$

$$\bar{y} = \frac{\Sigma \bar{y}L}{\Sigma L} = \frac{8}{10.2832} = 0.778 \text{ ft} \quad \text{Ans}$$

$$\bar{z} = \frac{\Sigma \bar{z}L}{\Sigma L} = \frac{8}{10.2832} = 0.778 \text{ ft} \quad \text{Ans}$$

$$W = (2 \text{ lb/ft})(10.2832 \text{ ft}) = 20.566 \text{ lb}$$

$$\Sigma M_x = 0; \quad M_{Ax} - 0.778(20.566) = 0$$

$$M_{Ax} = 16.0 \text{ lb-ft} \quad \text{Ans}$$

$$\Sigma M_y = 0; \quad M_{Ay} - (4 - 1.22)(20.566) = 0$$

$$M_{Ay} = 57.1 \text{ lb-ft} \quad \text{Ans}$$

$$\Sigma M_z = 0; \quad M_{Az} = 0 \quad \text{Ans}$$

$$\Sigma F_x = 0; \quad A_x = 0 \quad \text{Ans}$$

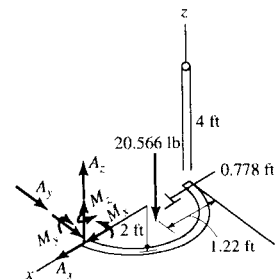
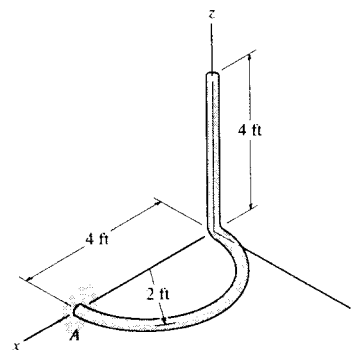

$$\Sigma F_y = 0; \quad A_y = 0 \quad \text{Ans}$$

$$\Sigma F_z = 0; \quad A_z = 2(10.2832) = 20.6 \text{ lb} \quad \text{Ans}$$

9-132. The rectangular bin is filled with coal, which creates a pressure distribution along wall A that varies as shown, i.e., $P = 4Z^{1/3}$ lb/ft², where Z is in feet. Compute the resultant force created by the coal, and its location, measured from that top surface of the coal.

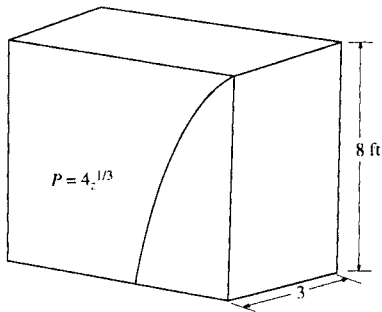

$$dF = f dA = 4Z^{1/3}(3)dZ$$

$$F = 12 \int_0^8 Z^{1/3} dZ$$

$$= 12 \left[\frac{3}{4} Z^{4/3} \right]_0^8$$

$$= 144 \text{ lb} \quad \text{Ans}$$

$$\int_A Z dF = 12 \int_0^8 Z^{4/3} dZ$$

$$= 12 \left[\frac{3}{7} Z^{7/3} \right]_0^8$$

$$= 658.29 \text{ lb-ft}$$

$$\bar{Z} = \frac{658.29}{144} = 4.57 \text{ ft} \quad \text{Ans}$$

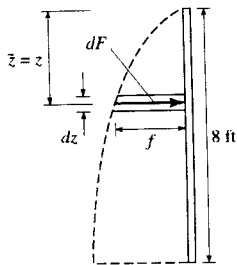

9-133. The load over the plate varies linearly along the sides of the plate such that $p = \frac{2}{3}[x(4 - y)]$ kPa. Determine the resultant force and its position (\bar{x}, \bar{y}) on the plate.

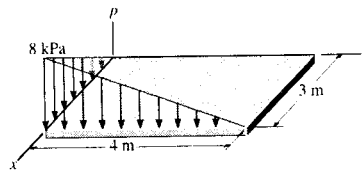

Resultant Force and its Location: The volume of the differential element is $dV = dF_R = p dx dy = \frac{2}{3}(x dx)[(4 - y) dy]$ and its centroid are $\bar{x} = x$ and $\bar{y} = y$.

$$F_R = \int_{F_R} dF_R = \int_0^3 \frac{2}{3}(x dx) \int_0^4 (4 - y) dy$$

$$= \frac{2}{3} \left[\left(\frac{x^2}{2} \right) \Big|_0^3 \left(4y - \frac{y^2}{2} \right) \Big|_0^4 \right] = 24.0 \text{ kN} \quad \text{Ans}$$

$$\int_{F_R} \bar{x} dF_R = \int_0^3 \frac{2}{3}(x^2 dx) \int_0^4 (4 - y) dy$$

$$= \frac{2}{3} \left[\left(\frac{x^3}{3} \right) \Big|_0^3 \left(4y - \frac{y^2}{2} \right) \Big|_0^4 \right] = 48.0 \text{ kN}\cdot\text{m}$$

$$\int_{F_R} \bar{y} dF_R = \int_0^3 \frac{2}{3}(x dx) \int_0^4 y(4 - y) dy$$

$$= \frac{2}{3} \left[\left(\frac{x^2}{2} \right) \Big|_0^3 \left(2y^2 - \frac{y^3}{3} \right) \Big|_0^4 \right] = 32.0 \text{ kN}\cdot\text{m}$$

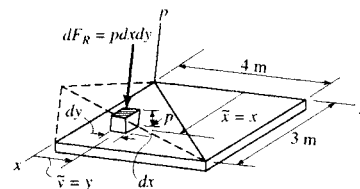

$$\bar{x} = \frac{\int_{F_R} \bar{x} dF_R}{\int_{F_R} dF_R} = \frac{48.0}{24.0} = 2.00 \text{ m} \quad \text{Ans}$$

$$\bar{y} = \frac{\int_{F_R} \bar{y} dF_R}{\int_{F_R} dF_R} = \frac{32.0}{24.0} = 1.33 \text{ m} \quad \text{Ans}$$

9-134. The pressure loading on the plate is described by the function $p = [-240/(x + 1) + 340]$ Pa. Determine the magnitude of the resultant force and coordinates of the point where the line of action of the force intersects the plate.

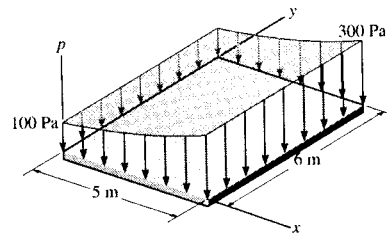

Resultant Force and its Location: The volume of the differential element is $dV = dF_R = 6p dx = 6 \left(-\frac{240}{x + 1} + 340 \right) dx$ and its centroid in $\bar{x} = x$.

$$F_R = \int_{F_R} dF_R = \int_0^5 6 \left(-\frac{240}{x + 1} + 340 \right) dx$$

$$= 6[-240 \ln(x + 1) + 340x^2] \Big|_0^5 \text{ m}$$

$$= 7619.87 \text{ N} = 7.62 \text{ kN} \quad \text{Ans}$$

$$\int_{F_R} \bar{x} dF_R = \int_0^5 6x \left(-\frac{240}{x + 1} + 340 \right) dx$$

$$= [-1440(x - \ln(x + 1)) + 1020x^2] \Big|_0^5 \text{ m}$$

$$= 20880.13 \text{ N}\cdot\text{m}$$

$$\bar{x} = \frac{\int_{F_R} \bar{x} dF_R}{\int_{F_R} dF_R} = \frac{20880.13}{7619.87} = 2.74 \text{ m} \quad \text{Ans}$$

Due to symmetry,

$$\bar{y} = 3.00 \text{ m} \quad \text{Ans}$$

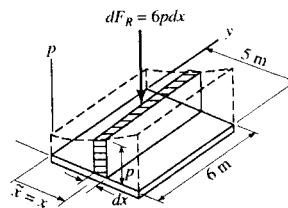

10-1. Determine the moment of inertia of the shaded area about the x axis.

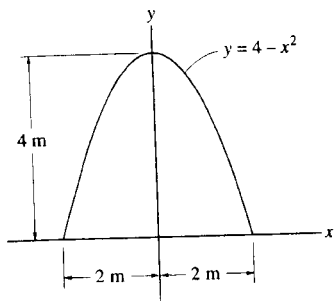

$$I_x = \int_0^4 y^2 dA = 2 \int_0^4 y^2 (x dy)$$

$$= 2 \int_0^4 y^2 \sqrt{4-y} dy$$

$$I_x = 2 \left[\frac{2(15y^2 + 12(4)y + 8(4)^2)(\sqrt{4-y})^3}{-105} \right]_0^4$$

$$I_x = 39.0 \text{ m}^4 \quad \text{Ans}$$

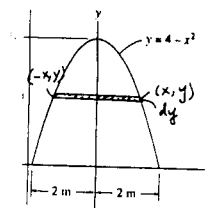

10-2. Determine the moment of inertia of the shaded area about the y axis.

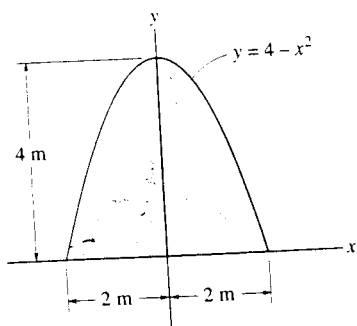

$$I_y = \int_A x^2 dA = 2 \int_0^2 x^2 (4-x^2) dx$$

$$= 2 \left[\frac{4x^3}{3} - \frac{x^5}{5} \right]_0^2$$

$$I_y = 8.53 \text{ m}^4 \quad \text{Ans}$$

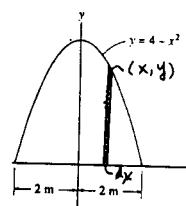

10-3. Determine the moment of inertia of the area about the x axis. Solve the problem in two ways, using rectangular differential elements: (a) having a thickness dx and (b) having a thickness of dy .

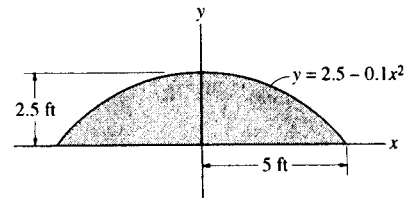

a) **Differential Element** : The area of the differential element parallel to y axis is $dA = ydx$. The moment of inertia of this element about x axis is

$$\begin{aligned} dI_x &= dI_x + dA\bar{y}^2 \\ &= \frac{1}{12}(dx)y^3 + ydx\left(\frac{y}{2}\right)^2 \\ &= \frac{1}{3}(2.5 - 0.1x^2)^3 dx \\ &= \frac{1}{3}(-0.001x^6 + 0.075x^4 - 1.875x^2 + 15.625) dx \end{aligned}$$

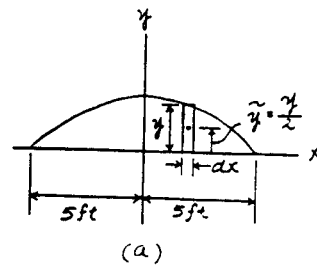

Moment of Inertia : Performing the integration, we have

$$\begin{aligned} I_x &= \int dI_x = \frac{1}{3} \int_{-5ft}^{5ft} (-0.001x^6 + 0.075x^4 - 1.875x^2 + 15.625) dx \\ &= \frac{1}{3} \left(-\frac{0.001}{7}x^7 + \frac{0.075}{5}x^5 - \frac{1.875}{3}x^3 + 15.625x \right) \Big|_{-5ft}^{5ft} \\ &= 23.8 \text{ ft}^4 \end{aligned}$$

Ans

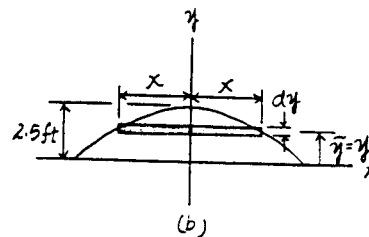

b) **Differential Element** : Here, $x = \sqrt{25 - 10y}$. The area of the differential element parallel to x axis is $dA = 2x dy = 2\sqrt{25 - 10y} dy$.

Moment of Inertia : Applying Eq. 10-1 and performing the integration, we have

$$\begin{aligned} I_x &= \int_A y^2 dA \\ &= 2 \int_0^{2.5ft} y^2 \sqrt{25 - 10y} dy \\ &= 2 \left[\frac{y^2}{15} (25 - 10y)^{3/2} - \frac{2y}{375} (25 - 10y)^{5/2} - \frac{2}{13125} (25 - 10y)^{7/2} \right] \Big|_0^{2.5ft} \\ &= 23.8 \text{ ft}^4 \end{aligned}$$

Ans

***10-4.** Determine the moment of inertia of the area about the x axis. Solve the problem in two ways, using rectangular differential elements: (a) having a thickness of dx , and (b) having a thickness of dy .

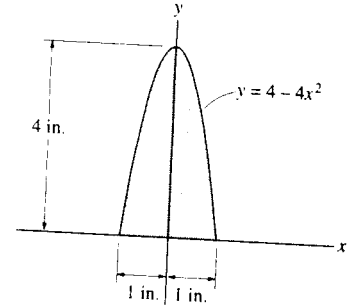

a) **Differential Element** : The area of the differential element parallel to y axis is $dA = y dx$. The moment of inertia of this element about x axis is

$$\begin{aligned} dI_x &= d\bar{I}_x + dA\bar{y}^2 \\ &= \frac{1}{12}(dx)y^3 + ydx\left(\frac{y}{2}\right)^2 \\ &= \frac{1}{3}(4-4x^2)^3 dx \\ &= \frac{1}{3}(-64x^6 + 192x^4 - 192x^2 + 64) dx \end{aligned}$$

Moment of Inertia : Performing the integration, we have

$$\begin{aligned} I_x &= \int dI_x = \frac{1}{3} \int_{-1.18}^{1.18} \frac{1}{3} (-64x^6 + 192x^4 - 192x^2 + 64) dx \\ &= \frac{1}{3} \left(-\frac{64}{7}x^7 + \frac{192}{5}x^5 - \frac{192}{3}x^3 + 64x \right) \Big|_{-1.18}^{1.18} \\ &= 19.5 \text{ in}^4 \end{aligned}$$

Ans

b) **Differential Element** : Here, $x = \frac{1}{2}\sqrt{4-y}$. The area of the differential element parallel to x axis is $dA = 2x dy = \sqrt{4-y} dy$.

Moment of Inertia : Applying Eq. 10-1 and performing the integration, we have

$$\begin{aligned} I_x &= \int_A y^2 dA \\ &= \int_0^{4.18} y^2 \sqrt{4-y} dy \\ &= \left[-\frac{2y^2}{3}(4-y)^{\frac{3}{2}} - \frac{8y}{15}(4-y)^{\frac{5}{2}} - \frac{16}{105}(4-y)^{\frac{7}{2}} \right]_0^{4.18} \\ &= 19.5 \text{ in}^4 \end{aligned}$$

Ans

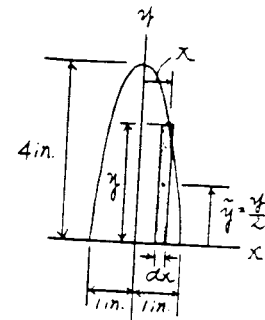

(a)

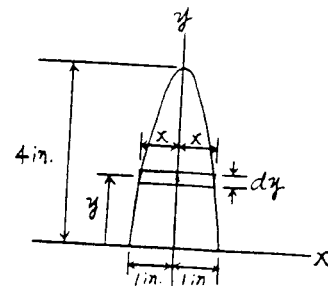

(b)

10-5. Determine the moment of inertia of the area about the y axis. Solve the problem in two ways, using rectangular differential elements: (a) having a thickness of dx , and (b) having a thickness of dy .

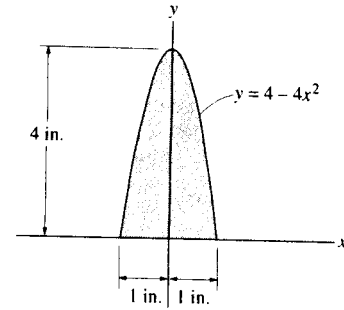

a) **Differential Element**: The area of the differential element parallel to y axis is $dA = y dx = (4 - 4x^2) dx$.

Moment of Inertia: Applying Eq. 10-1 and performing the integration, we have

$$I_y = \int_A x^2 dA = \int_{-1 \text{ in.}}^{1 \text{ in.}} x^2 (4 - 4x^2) dx$$

$$= \left[\frac{4}{3} x^3 - \frac{4}{5} x^5 \right]_{-1 \text{ in.}}^{1 \text{ in.}}$$

$$= 1.07 \text{ in}^4 \quad \text{Ans}$$

b) **Differential Element**: Here, $x = \frac{1}{2} \sqrt{4-y}$. The moment of inertia of the differential element about y axis is

$$dI_y = \frac{1}{12} (dy) (2x^3) = \frac{2}{3} x^3 dy = \frac{1}{12} (4-y)^{3/2} dy$$

Moment of Inertia: Performing the integration, we have

$$I_y = \int dI_y = \frac{1}{12} \int_0^{4 \text{ in.}} (4-y)^{3/2} dy$$

$$= \frac{1}{12} \left[-\frac{2}{5} (4-y)^{5/2} \right]_0^{4 \text{ in.}}$$

$$= 1.07 \text{ in}^4 \quad \text{Ans}$$

10-6. Determine the moment of inertia of the shaded area about the x axis.

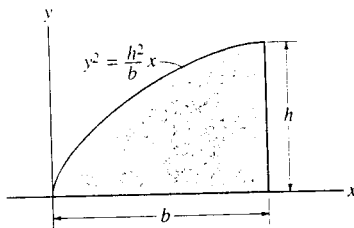

$$dI_x = \frac{1}{3} y^3 dx$$

$$I_x = \int dI_x$$

$$= \int_0^b \frac{y^3}{3} dy = \int_0^b \frac{1}{3} \left(\frac{h^2}{b} x \right)^{3/2} x^{1/2} dx$$

$$= \frac{1}{3} \left(\frac{h^2}{b} \right)^{3/2} \left(\frac{2}{5} \right) x^{5/2} \Big|_0^b$$

$$= \frac{2}{15} b h^3 \quad \text{Ans}$$

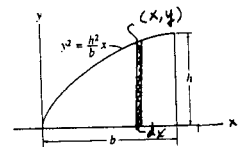

Also,

$$dA = (b-x) dy = \left(b - \frac{b}{h^2} y^2 \right) dy$$

$$I_x = \int y^2 dA$$

$$= \int_0^h y^2 \left(b - \frac{b}{h^2} y^2 \right) dy$$

$$= \left[\frac{b}{3} y^3 - \frac{b}{5 h^2} y^5 \right]_0^h$$

$$= \frac{2}{15} b h^3 \quad \text{Ans}$$

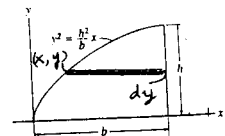

10-7. Determine the moment of inertia of the shaded area about the x axis.

Differential Element : The area of the differential element parallel to y axis is $dA = ydx$. The moment of inertia of this element about x axis is

$$\begin{aligned} dI_x &= d\bar{I}_x + dA\bar{y}^2 \\ &= \frac{1}{12}(dx)y^3 + ydx\left(\frac{y}{2}\right)^2 \\ &= \frac{1}{3}(2-2x^3)^3 dx \\ &= \frac{1}{3}(-8x^9 + 24x^6 - 24x^3 + 8) dx \end{aligned}$$

Moment of Inertia : Performing the integration, we have

$$\begin{aligned} I_x &= \int dI_x = \frac{1}{3} \int_0^{1 \text{ in.}} (-8x^9 + 24x^6 - 24x^3 + 8) dx \\ &= \frac{1}{3} \left(-\frac{8}{10}x^{10} + \frac{24}{7}x^7 - 6x^4 + 8x \right) \Big|_0^{1 \text{ in.}} \\ &= 1.54 \text{ in}^4 \end{aligned}$$

Ans

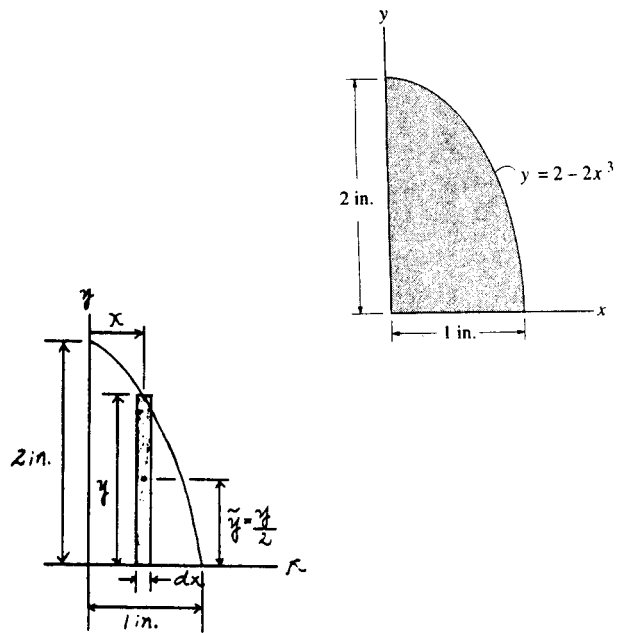

*10-8. Determine the moment of inertia of the shaded area about the y axis.

Differential Element : The area of the differential element parallel to y axis is $dA = ydx = (2-2x^3) dx$.

Moment of Inertia : Applying Eq. 10-1 and performing the integration, we have

$$\begin{aligned} I_y &= \int_A x^2 dA = \int_0^{1 \text{ in.}} x^2 (2-2x^3) dx \\ &= \left[\frac{2}{3}x^3 - \frac{1}{3}x^6 \right] \Big|_0^{1 \text{ in.}} \\ &= 0.333 \text{ in}^4 \end{aligned}$$

Ans

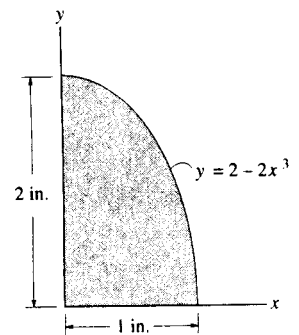

10-9. Determine the moment of inertia of the shaded area about the x axis.

Differential Element : Here, $x = \frac{b}{\sqrt{h}}y^{\frac{1}{2}}$. The area of the differential element

parallel to x axis is $dA = xdy = \left(\frac{b}{\sqrt{h}}y^{\frac{1}{2}}\right)dy$.

Moment of Inertia : Applying Eq. 10-1 and performing the integration, we have

$$\begin{aligned} I_x &= \int_A y^2 dA = \int_0^h y^2 \left(\frac{b}{\sqrt{h}}y^{\frac{1}{2}}\right) dy \\ &= \frac{b}{\sqrt{h}} \left(\frac{2}{7}y^{\frac{7}{2}}\right) \Big|_0^h \\ &= \frac{2}{7}bh^3 \end{aligned} \quad \text{Ans}$$

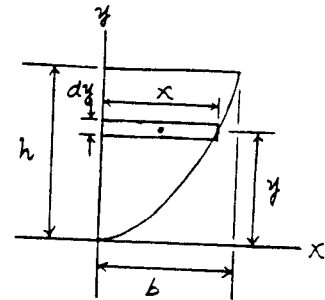
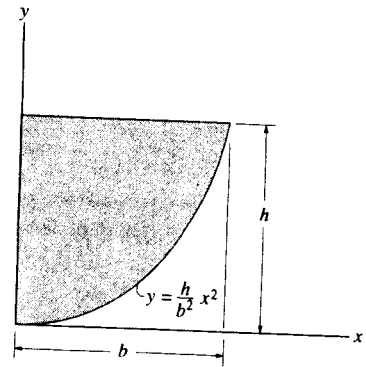

10-10. Determine the moment of inertia of the shaded area about the y axis.

Differential Element : The area of the differential element parallel to y axis is

$$dA = (h-y)dx = \left(h - \frac{h}{b^2}x^2\right)dx.$$

Moment of Inertia : Applying Eq. 10-1 and performing the integration, we have

$$\begin{aligned} I_y &= \int_A x^2 dA = \int_0^b x^2 \left(h - \frac{h}{b^2}x^2\right) dx \\ &= \left(\frac{h}{3}x^3 - \frac{h}{5b^2}x^5\right) \Big|_0^b \\ &= \frac{2}{15}hb^3 \end{aligned} \quad \text{Ans}$$

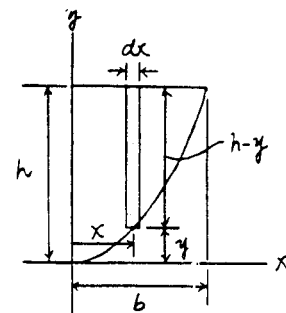
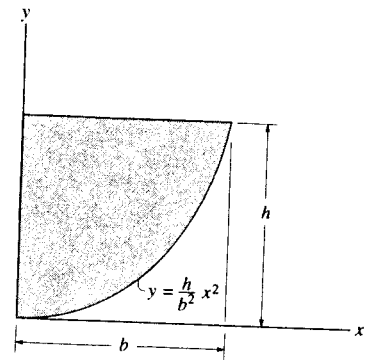

10-11. Determine the moment of inertia of the shaded area about the x axis.

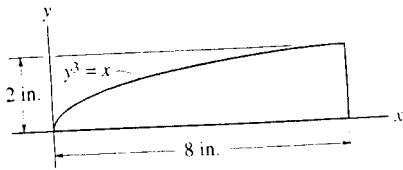

$$dI_x = d\bar{I}_x + dA y^2$$

$$= \frac{1}{12} dx y^3 + y dx \left(\frac{y}{2}\right)^2$$

$$= \frac{1}{3} y^3 dx$$

$$I_x = \int dI_x$$

$$= \int_0^8 \frac{1}{3} y^3 dx$$

$$= \int_0^8 \frac{1}{3} x dx$$

$$= \left[\frac{x^2}{6} \right]_0^8 = 10.7 \text{ in}^4 \quad \text{Ans}$$

Also,

$$I_x = \int y^2 dA$$

$$= \int_0^2 y^2 (8 - y^3) dy$$

$$= \left[\frac{8y^3}{3} - \frac{y^6}{6} \right]_0^2$$

$$= 10.7 \text{ in}^4 \quad \text{Ans}$$

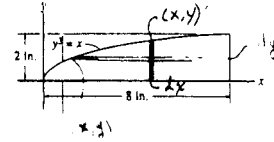

*10-12. Determine the moment of inertia of the shaded area about the x axis.

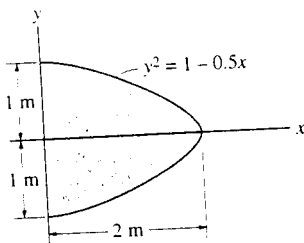

$$dI_x = \frac{1}{12} dx (2y)^3$$

$$I_x = \int dI_x$$

$$= \int_0^2 \frac{2}{3} (1 - 0.5x)^{3/2} dx$$

$$= \frac{2}{3} \left[\frac{2}{5(-0.5)} (1 - 0.5x)^{5/2} \right]_0^2$$

$$= 0.533 \text{ m}^4 \quad \text{Ans}$$

Also,

$$dA = x dy = 2(1 - y^2) dy$$

$$I_x = \int y^2 dA$$

$$= \int_{-1}^1 2y^2(1 - y^2) dy$$

$$= 2 \left[\frac{y^3}{3} - \frac{y^5}{5} \right]_{-1}^1$$

$$= 0.533 \text{ m}^4 \quad \text{Ans}$$

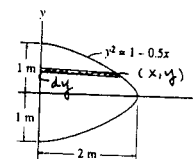
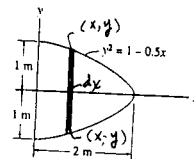

10-13. Determine the moment of inertia of the shaded area about the y axis.

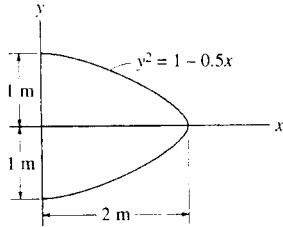

$$dA = 2y dx$$

$$I_y = \int x^2 dA$$

$$= \int_0^2 2x^2(1-0.5x)^{1/2} dx$$

$$= 2 \left[\frac{2(8+12(-0.5)x + 15(-0.5)^2 x^2) \sqrt{(1-0.5x)^3}}{105(-0.5)^3} \right]_0^2$$

$$= 2.44 \text{ m}^4 \quad \text{Ans}$$

Also,

$$I_y = \int dI_y$$

$$= 2 \int_0^1 \frac{1}{3} x^3 dy$$

$$= 2 \int_0^1 \frac{8}{3} (1-y^2)^3 dy$$

$$= 2 \left(\frac{8}{3} \right) \left[y - y^3 + \frac{3}{5} y^5 - \frac{1}{7} y^7 \right]_0^1$$

$$= 2.44 \text{ m}^4 \quad \text{Ans}$$

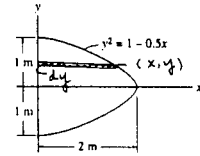
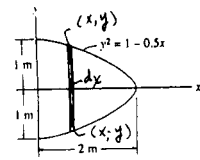

10-14. Determine the moment of inertia of the shaded area about the x axis.

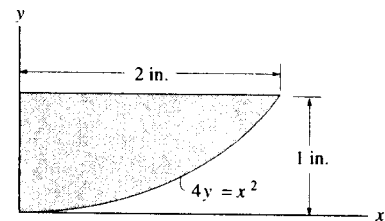

Differential Element : Here, $x = 2y^{1/2}$. The area of the differential element parallel to x axis is $dA = x dy = (2y^{1/2}) dy$.

Moment of Inertia : Applying Eq. 10-1 and performing the integration, we have

$$\begin{aligned} I_x &= \int_A y^2 dA = \int_0^{1 \text{ in.}} y^2 (2y^{1/2}) dy \\ &= \left(\frac{4}{7} y^{7/2} \right) \Big|_0^{1 \text{ in.}} \\ &= 0.571 \text{ in}^4 \end{aligned}$$

Ans

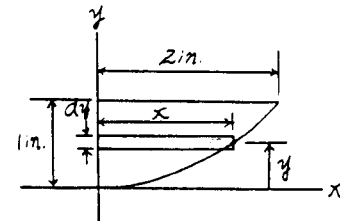

10-15. Determine the moment of inertia of the shaded area about the y axis.

Differential Element: The area of the differential element parallel to y axis is $dA = (1 - y)dx = \left(1 - \frac{1}{4}x^2\right) dx$.

Moment of Inertia: Applying Eq. 10-1 and performing the integration, we have

$$\begin{aligned} I_y &= \int_A x^2 dA = \int_0^{2 \text{ in.}} x^2 \left(1 - \frac{1}{4}x^2\right) dx \\ &= \left(\frac{1}{3}x^3 - \frac{1}{20}x^5\right) \Big|_0^{2 \text{ in.}} \\ &= 1.07 \text{ in}^4 \quad \text{Ans} \end{aligned}$$

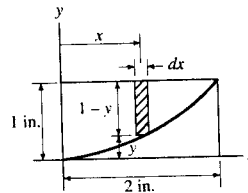
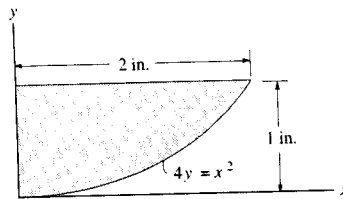

***10-16.** Determine the moment of inertia of the area about the y axis. Use Simpson's rule to evaluate the integral.

$$\begin{aligned} I_y &= \int x^2 dA \\ &= \int_0^1 x^2 (0.5e^{x^2}) dx \\ &= 0.314 \text{ m}^4 \quad \text{Ans} \end{aligned}$$

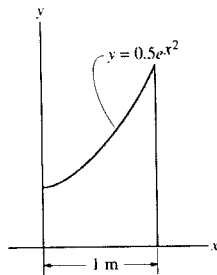
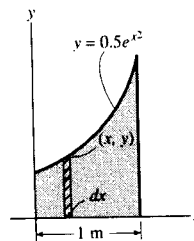

10-17. Determine the moment of inertia of the area about the x axis. Use Simpson's rule to evaluate the integral.

$$\begin{aligned} dI_x &= \frac{1}{3} dx y^3 \\ I_x &= \int_0^1 \frac{1}{3} (0.5e^{x^2})^3 dx \\ &= \frac{1}{24} \int_0^1 (e^{x^2})^3 dx \\ &= 0.176 \text{ m}^4 \quad \text{Ans} \end{aligned}$$

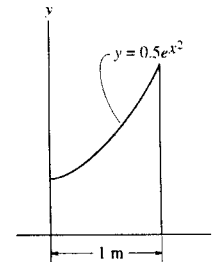
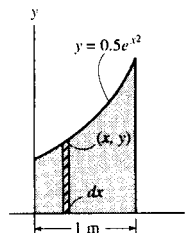

10-18. Determine the moment of inertia of the shaded area about the x axis.

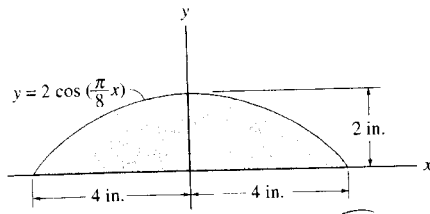

$$dI_x = dI_{\bar{x}} + dA \bar{y}^2$$

$$= \frac{1}{12} dx y^3 + y dx \left(\frac{y}{2}\right)^2 = \frac{1}{3} y^3 dx$$

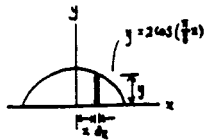

$$I_x = \int_A dI_x = \int_{-4}^4 \frac{8}{3} \cos^3\left(\frac{\pi}{8}x\right) dx$$

$$= \frac{8}{3} \left[\frac{\sin\left(\frac{\pi}{8}x\right)}{\frac{\pi}{8}} - \frac{\sin^3\left(\frac{\pi}{8}x\right)}{\frac{3\pi}{8}} \right]_{-4}^4 = \frac{256}{9\pi} = 9.05 \text{ in}^4 \quad \text{Ans}$$

10-19. Determine the moment of inertia of the shaded area about the y axis.

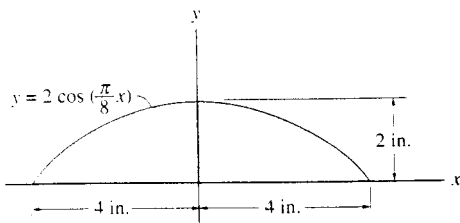

$$I_y = \int_A x^2 dA = \int_{-4}^4 x^2 2 \cos\left(\frac{\pi}{8}x\right) dx$$

$$= 2 \left[\frac{x^2 \sin\left(\frac{\pi}{8}x\right)}{\frac{\pi}{8}} + \frac{2x \cos\left(\frac{\pi}{8}x\right)}{\left(\frac{\pi}{8}\right)^2} - \frac{2 \sin\left(\frac{\pi}{8}x\right)}{\left(\frac{\pi}{8}\right)^3} \right]_{-4}^4$$

$$= 4 \left(\frac{128}{\pi} - \frac{1024}{\pi^3} \right) = 30.9 \text{ in}^4 \quad \text{Ans}$$

*10-20. Determine the moment of inertia of the shaded area about the x axis.

Differential Element : Here, $x = y^{\frac{1}{3}}$. The area of the differential element parallel to x axis is $dA = x dy = y^{\frac{1}{3}} dy$.

Moment of Inertia : Applying Eq. 10-1 and performing the integration, we have

$$I_x = \int_A y^2 dA = \int_0^{8 \text{ in.}} y^2 (y^{\frac{1}{3}}) dy$$

$$= \left[\frac{3}{10} y^{\frac{10}{3}} \right]_0^{8 \text{ in.}}$$

$$= 307 \text{ in}^4$$

Ans

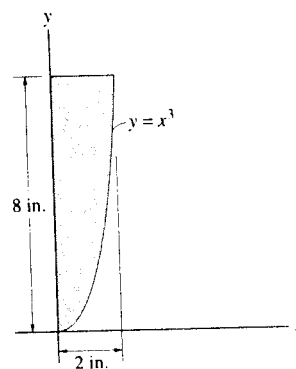
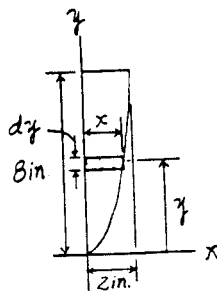

10-21. Determine the moment of inertia of the shaded area about the y axis.

Differential Element : The area of the differential element parallel to y axis is $dA = (8 - y) dx = (8 - x^3) dx$.

Moment of Inertia : Applying Eq. 10-1 and performing the integration, we have

$$I_y = \int_A x^2 dA = \int_0^{2 \text{ in.}} x^2 (8 - x^3) dx$$

$$= \left(\frac{8}{3} x^3 - \frac{1}{6} x^6 \right) \Big|_0^{2 \text{ in.}}$$

$$= 10.7 \text{ in}^4$$

Ans

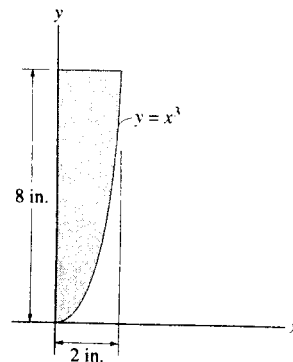
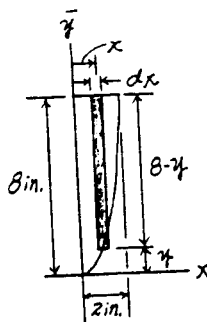

10-22. Determine the moment of inertia of the shaded area about the x axis.

$$dA = x dy = \frac{y^2}{2} dy$$

$$I_x = \int y^2 dA$$

$$= \int_0^2 \frac{y^4}{2} dy$$

$$= \left[\frac{y^5}{10} \right]_0^2$$

$$= 3.20 \text{ m}^4 \quad \text{Ans}$$

Also,

$$dA = (2 - \sqrt{2x}) dx$$

$$dI_x = dI_{\bar{x}} + dA \bar{y}^2$$

$$= \frac{1}{12} dx (2 - \sqrt{2x})^3 + (2 - \sqrt{2x}) dx \left(\frac{2 - \sqrt{2x}}{2} + \sqrt{2x} \right)^2$$

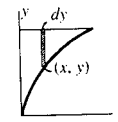
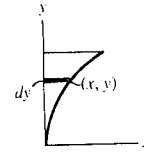
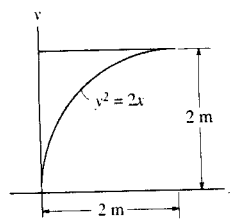

$$= \frac{1}{12} (2 - \sqrt{2x})^3 dx + \frac{1}{4} (2 - \sqrt{2x})(2 + \sqrt{2x})^2 dx$$

$$I_x = \int dI_x$$

$$= \int_0^2 \left[\frac{1}{12} (2 - \sqrt{2x})^3 + \frac{1}{4} (2 - \sqrt{2x})(2 + \sqrt{2x})^2 \right] dx$$

$$= 3.20 \text{ m}^4 \quad \text{Ans}$$

10-23. Determine the moment of inertia of the shaded area about the y axis. Use Simpson's rule to evaluate the integral.

Area of the differential element (shaded) $dA = y dx$ where $y = e^{x^2}$, hence, $dA = y dx = e^{x^2} dx$.

$$I_y = \int_A x^2 dA = \int_0^1 x^2 (e^{x^2}) dx$$

Use Simpson's rule to evaluate the integral: (to 500 intervals)

$$I_y = 0.628 \text{ m}^4$$

Ans

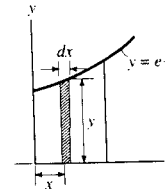
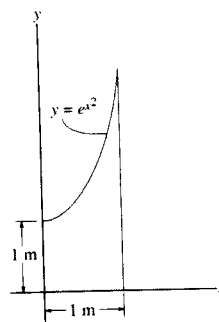

10-24. Determine the moment of inertia of the shaded area about the x axis. Use Simpson's rule to evaluate the integral.

$$dI_x = dI_{\bar{x}} + dA \bar{y}^2$$

$$= \frac{1}{12} dx y^3 + y dx \left(\frac{y}{2} \right)^2 = \frac{1}{3} y^3 dx$$

$$I_x = \frac{1}{3} \int_0^1 y^3 dx = \frac{1}{3} \int_0^1 (e^{x^2})^3 dx = 1.41 \text{ m}^4 \quad \text{Ans}$$

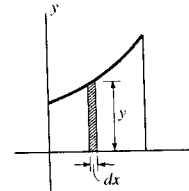
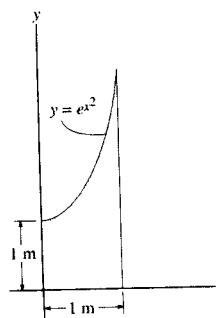

10-25. The polar moment of inertia of the area is $\bar{J}_C = 23 \text{ in}^4$ about the z axis passing through the centroid C . If the moment of inertia about the y' axis is 5 in^4 , and the moment of inertia about the x axis is 40 in^4 , determine the area A .

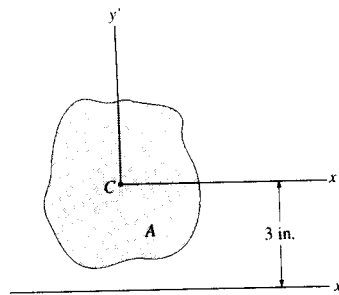

Moment of Inertia: The polar of moment inertia $\bar{J}_C = \bar{I}_{x'} + \bar{I}_{y'}$. Then, $\bar{I}_{y'} = \bar{J}_C - \bar{I}_{x'} = 23 - 5 = 18.0 \text{ in}^4$. Applying the parallel-axis theorem, Eq. 10-3, we have

$$I_x = \bar{I}_{x'} + Ad^2$$

$$40 = 18.0 + A(3^2)$$

$$A = 2.44 \text{ in}^2 \quad \text{Ans}$$

10-26. The polar moment of inertia of the area is $\bar{J}_C = 548(10^6) \text{ mm}^4$, about the z' axis passing through the centroid C . The moment of inertia about the y' axis is $383(10^6) \text{ mm}^4$, and the moment of inertia about the x axis is $856(10^6) \text{ mm}^4$. Determine the area A .

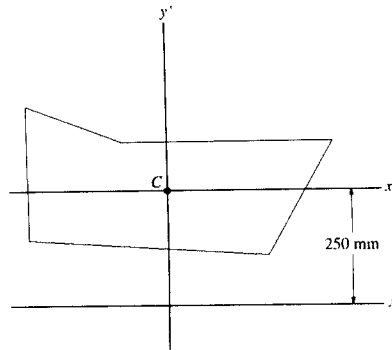

$$I_x = \bar{I}_{x'} + Ad^2 = 856(10^6) - A(250)^2$$

$$\bar{J}_C = \bar{I}_{x'} + \bar{I}_{y'}$$

$$548(10^6) = 856(10^6) - A(250)^2 + 383(10^6)$$

$$A = 11.1(10^3) \text{ mm}^2 \quad \text{Ans}$$

10-27. The beam is constructed from the two channels and two cover plates. If each channel has a cross-sectional area of $A_c = 11.8 \text{ in}^2$ and a moment of inertia about a horizontal axis passing through its own centroid, C_c , of $(\bar{J}_x)_{C_c} = 349 \text{ in}^4$, determine the moment of inertia of the beam about the x axis.

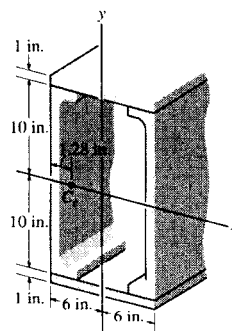

$$I_x = 2 \left[\frac{1}{12} (12)(1)^3 + (1)(12)(10.5)^2 \right] + 2(349)$$

$$= 3.35(10^3) \text{ in}^4 \quad \text{Ans}$$

***10-28.** The beam is constructed from the two channels and two cover plates. If each channel has a cross-sectional area of $A_c = 11.8 \text{ in}^2$ and a moment of inertia about a vertical axis passing through its own centroid, C_c , of $(I_y)_{C_c} = 9.23 \text{ in}^4$, determine the moment of inertia of the beam about the y axis.

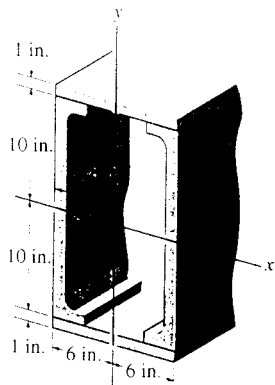

$$I_y = 2 \left[\frac{1}{12} (1)(12)^3 \right] + 2[(9.23) + 11.8(6 - 1.28)^2]$$

$$= 832 \text{ in}^4 \quad \text{Ans}$$

10-29. Determine the moment of inertia of the beam's cross-sectional area with respect to the x' centroidal axis. Neglect the size of all the rivet heads, R , for the calculation. Handbook values for the area, moment of inertia, and location of the centroid C of one of the angles are listed in the figure.

$$I_{x'} = \frac{1}{12} (15)(275)^3 + 4 \left[1.32(10^6) + 1.36(10^3) \left(\frac{275}{2} - 28 \right)^2 \right]$$

$$+ 2 \left[\frac{1}{12} (75)(20)^3 + (75)(20) \left(\frac{275}{2} + 10 \right)^2 \right] = 162(10^6) \text{ mm}^4 \quad \text{Ans}$$

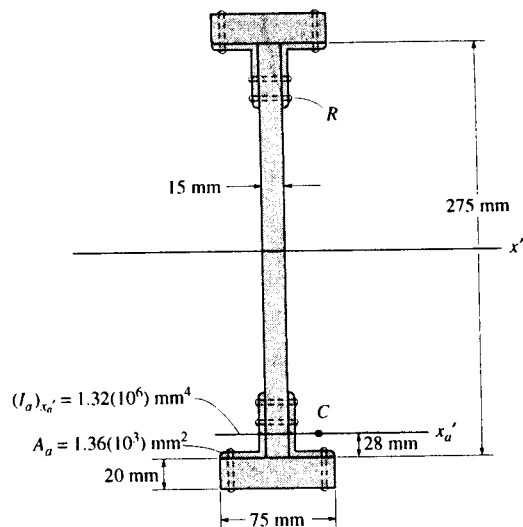

10-30. Locate the centroid \bar{y} of the cross-sectional area for the angle. Then find the moment of inertia $\bar{I}_{x'}$ about the x' centroidal axis.

Centroid: The area of each segment and its respective centroid are tabulated below.

| Segment | $A(\text{in}^2)$ | $\bar{y}(\text{in.})$ | $\bar{y}A(\text{in}^3)$ |
|----------|------------------|-----------------------|-------------------------|
| 1 | 6(2) | 3 | 36.0 |
| 2 | 6(2) | 1 | 12.0 |
| Σ | 24.0 | | 48.0 |

Thus,

$$\bar{y} = \frac{\Sigma \bar{y}A}{\Sigma A} = \frac{48.0}{24.0} = 2.00 \text{ in.} \quad \text{Ans}$$

Moment of Inertia: The moment of inertia about the x' axis for each segment can be determined using the parallel-axis theorem $I_{x'} = I_x + Ad_{x'}^2$.

| Segment | $A_i(\text{in}^2)$ | $(d_{y'})_i(\text{in.})$ | $(\bar{I}_{x'})_i(\text{in}^4)$ | $(Ad_{y'}^2)_i(\text{in}^4)$ | $(I_{x'})_i(\text{in}^4)$ |
|---------|--------------------|--------------------------|---------------------------------|------------------------------|---------------------------|
| 1 | 2(6) | 1 | $\frac{1}{12}(2)(6^3)$ | 12.0 | 48.0 |
| 2 | 6(2) | 1 | $\frac{1}{12}(6)(2^3)$ | 12.0 | 16.0 |

Thus,

$$\bar{I}_{x'} = \Sigma (I_{x'})_i = 64.0 \text{ in}^4 \quad \text{Ans}$$

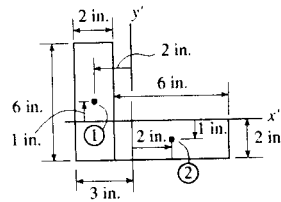
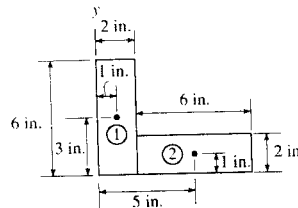
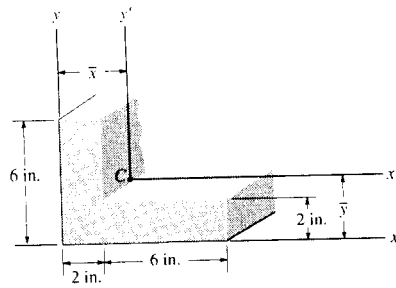

10-31. Locate the centroid \bar{x} of the cross-sectional area for the angle. Then find the moment of inertia $\bar{I}_{y'}$ about the y' centroidal axis.

Centroid: The area of each segment and its respective centroid are tabulated below.

| Segment | $A(\text{in}^2)$ | $\bar{x}(\text{in.})$ | $\bar{x}A(\text{in}^3)$ |
|----------|------------------|-----------------------|-------------------------|
| 1 | 6(2) | 1 | 12.0 |
| 2 | 6(2) | 5 | 60.0 |
| Σ | 24.0 | | 72.0 |

Thus,

$$\bar{x} = \frac{\Sigma \bar{x}A}{\Sigma A} = \frac{72.0}{24.0} = 3.00 \text{ in.} \quad \text{Ans}$$

Moment of Inertia: The moment of inertia about the y' axis for each segment can be determined using the parallel-axis theorem $I_{y'} = \bar{I}_y + Ad_{y'}^2$.

| Segment | $A_i(\text{in}^2)$ | $(d_x)_{y'}(\text{in.})$ | $(\bar{I}_{y'})_i(\text{in}^4)$ | $(Ad_{x'}^2)_i(\text{in}^4)$ | $(I_{y'})_i(\text{in}^4)$ |
|---------|--------------------|--------------------------|---------------------------------|------------------------------|---------------------------|
| 1 | 6(2) | 2 | $\frac{1}{12}(6)(2^3)$ | 48.0 | 52.0 |
| 2 | 2(6) | 2 | $\frac{1}{12}(2)(6^3)$ | 48.0 | 84.0 |

Thus,

$$\bar{I}_{y'} = \Sigma (I_{y'})_i = 136 \text{ in}^4 \quad \text{Ans}$$

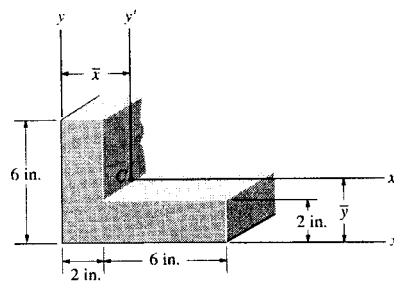

*10-32. Determine the distance \bar{x} to the centroid of the beam's cross-sectional area; then find the moment of inertia about the y' axis.

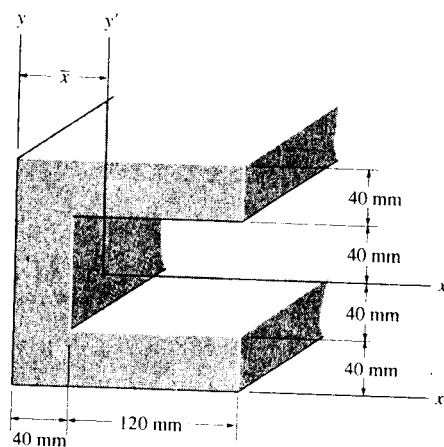

Centroid : The area of each segment and its respective centroid are tabulated below.

| Segment | A (mm ²) | \bar{x} (mm) | $\bar{x}A$ (mm ³) |
|----------|------------------------|----------------|-------------------------------|
| 1 | 160(80) | 80 | 1.024(10 ⁶) |
| 2 | 40(80) | 20 | 64.0(10 ³) |
| Σ | 16.0(10 ³) | | 1.088(10 ⁶) |

Thus,

$$\bar{x} = \frac{\Sigma \bar{x}A}{\Sigma A} = \frac{1.088(10^6)}{16.0(10^3)} = 68.0 \text{ mm} \quad \text{Ans}$$

Moment of Inertia : The moment of inertia about the y' axis for each segment can be determined using the parallel-axis theorem $I_{y'} = \bar{I}_y + Ad_x^2$.

| Segment | A_i (mm ²) | $(d_x)_i$ (mm) | $(\bar{I}_y)_i$ (mm ⁴) | $(Ad_x^2)_i$ (mm ⁴) | $(I_{y'})_i$ (mm ⁴) |
|---------|--------------------------|----------------|------------------------------------|---------------------------------|---------------------------------|
| 1 | 80(160) | 12.0 | $\frac{1}{12}(80)(160^3)$ | 1.8432(10 ⁶) | 29.150(10 ⁶) |
| 2 | 80(40) | 48.0 | $\frac{1}{12}(80)(40^3)$ | 7.3728(10 ⁶) | 7.799(10 ⁶) |

Thus,

$$I_{y'} = \Sigma (I_{y'})_i = 36.949(10^6) \text{ mm}^4 = 36.9(10^6) \text{ mm}^4 \quad \text{Ans}$$

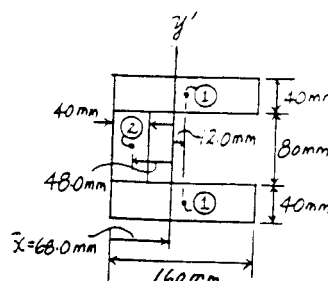
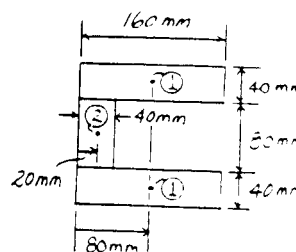

10-33. Determine the moment of inertia of the beam's cross-sectional area about the x' axis.

Moment of Inertia : The moment inertia for the rectangle about its centroidal axis can be determined using the formula, $I_x = \frac{1}{12}bh^3$, given on the inside back cover of the textbook.

$$I_{x'} = \frac{1}{12}(160)(160^3) - \frac{1}{12}(120)(80^3) = 49.5(10^6) \text{ mm}^4 \quad \text{Ans}$$

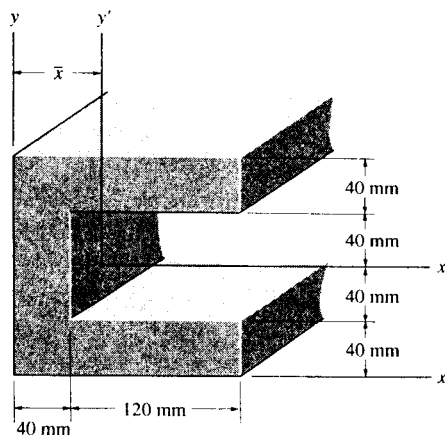

10-34. Determine the moments of inertia of the shaded area about the x and y axes.

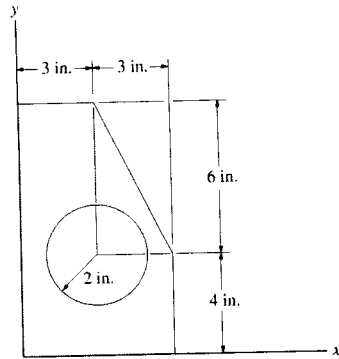

$$I_x = \left[\frac{1}{12}(6)(10)^3 + 6(10)(5)^2 \right] - \left[\frac{1}{36}(3)(6)^3 + \left(\frac{1}{2}\right)(3)(6)(8)^2 \right]$$

$$- \left[\frac{1}{4}\pi(2)^4 + \pi(2)^2(4)^2 \right] = 1.192(10^3) \quad \text{Ans}$$

$$I_y = \left[\frac{1}{12}(10)(6)^3 + 6(10)(3)^2 \right] - \left[\frac{1}{36}(6)(3)^3 + \left(\frac{1}{2}\right)(6)(3)(5)^2 \right]$$

$$- \left[\frac{1}{4}\pi(2)^4 + \pi(2)^2(3)^2 \right] = 364.8 \text{ in}^4 \quad \text{Ans}$$

10-35. Determine the moment of inertia of the beam's cross-sectional area about the x' axis. Neglect the size of the corner welds at A and B for the calculation, $\bar{y} = 154.4 \text{ mm}$.

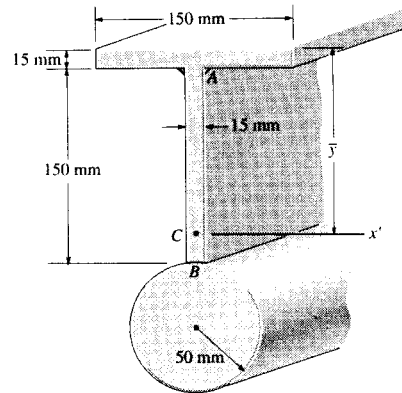

Moment of Inertia: The moment of inertia about the x' axis for each segment can be determined using the parallel-axis theorem $I_x = \bar{I}_x + Ad^2$.

| Segment | $A_i(\text{mm}^2)$ | $(d_y)_i(\text{mm})$ | $(\bar{I}_x)_i(\text{mm}^4)$ | $(Ad^2)_i(\text{mm}^4)$ | $(I_x)_i(\text{mm}^4)$ |
|---------|--------------------|----------------------|------------------------------|-------------------------|------------------------|
| 1 | 150(15) | 146.9 | $\frac{1}{12}(150)(15^3)$ | $48.554(10^6)$ | $48.596(10^6)$ |
| 2 | 15(150) | 64.4 | $\frac{1}{12}(15)(150^3)$ | $9.332(10^6)$ | $13.550(10^6)$ |
| 3 | $\pi(50^2)$ | 60.6 | $\frac{\pi}{4}(50^4)$ | $28.843(10^6)$ | $33.751(10^6)$ |

Thus,

$$I_{x'} = \Sigma(I_x)_i = 95.898(10^6) \text{ mm}^4 = 95.9(10^6) \text{ mm}^4 \quad \text{Ans}$$

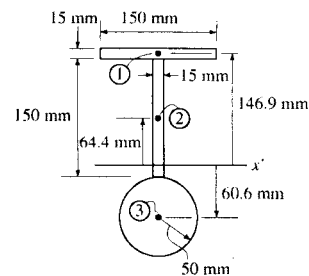

*10-36. Compute the moments of inertia I_x and I_y for the beam's cross-sectional area: about the x and y axes.

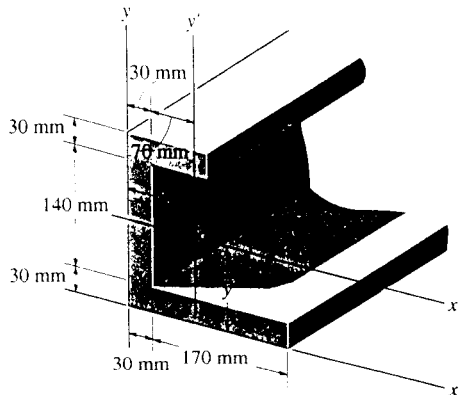

$$I_x = \frac{1}{12}(170)(30)^3 + 170(30)(15)^2 + \frac{1}{12}(30)(170)^3 + 30(170)(85)^2 + \frac{1}{12}(100)(30)^3 + 100(30)(185)^2$$

$$I_x = 154(10^6) \text{ mm}^4 \quad \text{Ans}$$

$$I_y = \frac{1}{12}(30)(170)^3 + 30(170)(115)^2 + \frac{1}{12}(170)(30)^3 + 30(170)(15)^2 + \frac{1}{12}(30)(100)^3 + 30(100)(50)^2$$

$$I_y = 91.3(10^6) \text{ mm}^4 \quad \text{Ans}$$

10-37. Determine the distance \bar{y} to the centroid C of the beam's cross-sectional area and then compute the moment of inertia \bar{I}_x about the x' axis.

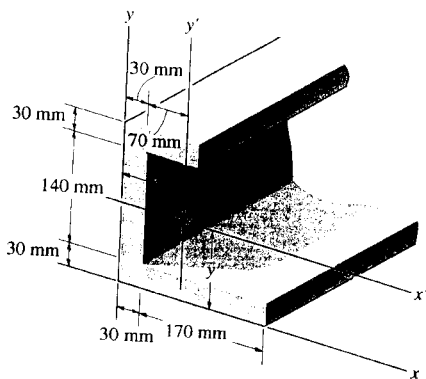

$$\bar{y} = \frac{170(30)(15) + 170(30)(85) + 100(30)(185)}{170(30) + 170(30) + 100(30)}$$

$$= 80.68 = 80.7 \text{ mm} \quad \text{Ans}$$

$$\bar{I}_x = \left[\frac{1}{12}(170)(30)^3 + 170(30)(80.68 - 15)^2 \right] + \left[\frac{1}{12}(30)(170)^3 + 30(170)(85 - 80.68)^2 \right] + \frac{1}{12}(100)(30)^3 + 100(30)(185 - 80.68)^2$$

$$\bar{I}_x = 67.6(10^6) \text{ mm}^4 \quad \text{Ans}$$

10-38. Determine the distance \bar{x} to the centroid C of the beam's cross-sectional area and then compute the moment of inertia \bar{I}_y about the y' axis.

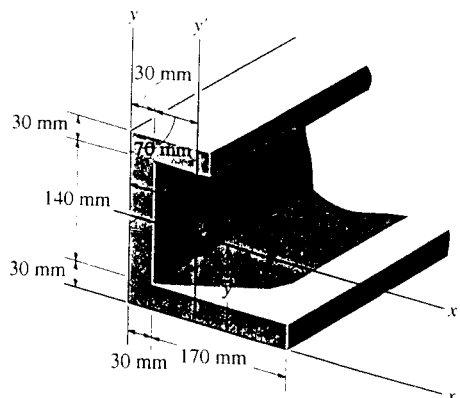

$$\bar{x} = \frac{170(30)(115) + 170(30)(15) + 100(30)(50)}{170(30) + 170(30) + 100(30)}$$

$$= 61.59 = 61.6 \text{ mm} \quad \text{Ans}$$

$$\bar{I}_y = \left[\frac{1}{12}(30)(170)^3 + 170(30)(115 - 61.59)^2 \right] + \left[\frac{1}{12}(170)(30)^3 + 30(170)(15 - 61.59)^2 \right] + \frac{1}{12}(30)(100)^3 + 100(30)(50 - 61.59)^2$$

$$\bar{I}_y = 41.2(10^6) \text{ mm}^4 \quad \text{Ans}$$

10-39. Locate the centroid \bar{y} of the cross section and determine the moment of inertia of the section about the x' axis.

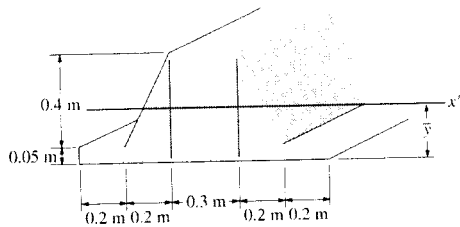

Centroid: The area of each segment and its respective centroid are tabulated below.

| Segment | $A(\text{m}^2)$ | $\bar{y}(\text{m})$ | $\bar{y}A(\text{m}^3)$ |
|----------|-------------------------|---------------------|------------------------|
| 1 | $0.3(0.4)$ | 0.25 | 0.03 |
| 2 | $\frac{1}{2}(0.4)(0.4)$ | 0.1833 | 0.014667 |
| 3 | $1.1(0.05)$ | 0.025 | 0.001375 |
| Σ | 0.255 | | 0.046042 |

Thus,

$$\bar{y} = \frac{\Sigma \bar{y}A}{\Sigma A} = \frac{0.046042}{0.255} = 0.1806 \text{ m} = 0.181 \text{ m} \quad \text{Ans}$$

Moment of Inertia: The moment of inertia about the x' axis for each segment can be determined using the parallel-axis theorem $I_x = I_c + Ad_c^2$.

| Segment | $A_i(\text{m}^2)$ | $(d_{y'})_i(\text{m})$ | $(\bar{I}_x)_i(\text{m}^4)$ | $(Ad_c^2)_i(\text{m}^4)$ | $(I_x)_i(\text{m}^4)$ |
|---------|-------------------------|------------------------|-----------------------------|--------------------------|-----------------------|
| 1 | $0.3(0.4)$ | 0.06944 | $\frac{1}{12}(0.3)(0.4)^3$ | $0.5787(10^{-3})$ | $2.1787(10^{-3})$ |
| 2 | $\frac{1}{2}(0.4)(0.4)$ | 0.002778 | $\frac{1}{36}(0.4)(0.4)^3$ | $0.6173(10^{-6})$ | $0.7117(10^{-3})$ |
| 3 | $1.1(0.05)$ | 0.1556 | $\frac{1}{12}(1.1)(0.05)^3$ | $1.3309(10^{-3})$ | $1.3423(10^{-3})$ |

Thus,

$$I_x = \Sigma (I_x)_i = 4.233(10^{-3}) \text{ m}^4 = 4.23(10^{-3}) \text{ m}^4 \quad \text{Ans}$$

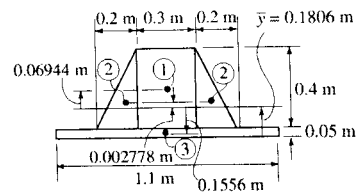
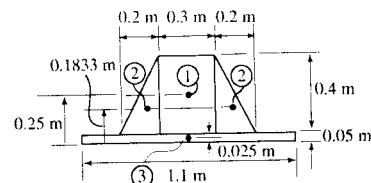

***10-40.** Determine \bar{y} , which locates the centroidal axis x' for the cross-sectional area of the T-beam, and then find the moments of inertia $\bar{I}_{x'}$ and $\bar{I}_{y'}$.

$$\bar{y} = \frac{\Sigma \bar{y}A}{\Sigma A} = \frac{125(250)(50) + (275)(50)(300)}{250(50) + 50(300)}$$

$$= 206.818 \text{ mm}$$

$$\bar{y} = 207 \text{ mm} \quad \text{Ans}$$

$$\bar{I}_{y'} = \left[\frac{1}{12}(50)(250)^3 + 50(250)(206.818 - 125)^2 \right]$$

$$+ \left[\frac{1}{12}(300)(50)^3 + 50(300)(275 - 206.818)^2 \right]$$

$$\bar{I}_{y'} = 222(10^6) \text{ mm}^4 \quad \text{Ans}$$

$$I_x = \frac{1}{12}(250)(50)^3 + \frac{1}{12}(50)(300)^3 = 115(10^6) \text{ mm}^4 \quad \text{Ans}$$

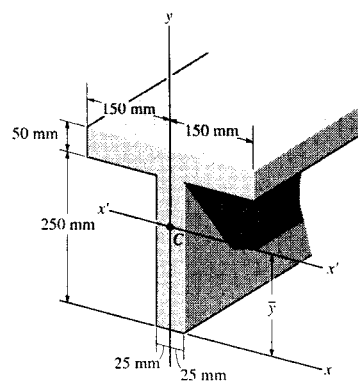

10-41. Determine the distance \bar{y} to the centroid for the beam's cross-sectional area; then determine the moment of inertia about the x' axis.

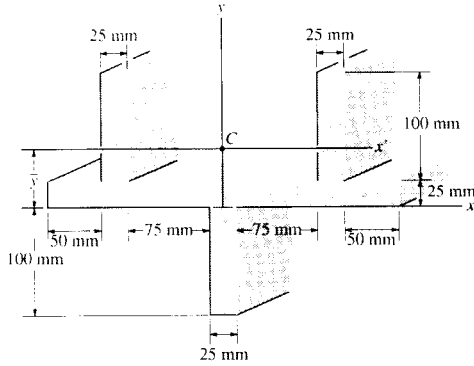

Centroid: The area of each segment and its respective centroid are tabulated below.

| Segment | $A(\text{mm}^2)$ | $\bar{y}(\text{mm})$ | $\bar{y}A(\text{mm}^3)$ |
|----------|------------------|----------------------|-------------------------|
| 1 | $50(100)$ | 75 | $375(10^3)$ |
| 2 | $325(25)$ | 12.5 | $101.5625(10^3)$ |
| 3 | $25(100)$ | -50 | $-125(10^3)$ |
| Σ | $15.625(10^3)$ | | $351.5625(10^3)$ |

Thus,

$$\bar{y} = \frac{\Sigma \bar{y}A}{\Sigma A} = \frac{351.5625(10^3)}{15.625(10^3)} = 22.5 \text{ mm Ans}$$

Moment of Inertia: The moment of inertia about the x' axis for each segment can be determined using the parallel-axis theorem $I_{x'} = I_c + Ad_c^2$.

| Segment | $A_i(\text{mm}^2)$ | $(d_y)_i(\text{mm})$ | $(\bar{I}_{x'})_i(\text{mm}^4)$ | $(Ad_y^2)_i(\text{mm}^4)$ | $(I_{x'})_i(\text{mm}^4)$ |
|---------|--------------------|----------------------|---------------------------------|---------------------------|---------------------------|
| 1 | $50(100)$ | 52.5 | $\frac{1}{12}(50)(100^3)$ | $13.781(10^6)$ | $17.948(10^6)$ |
| 2 | $325(25)$ | 10 | $\frac{1}{12}(325)(25^3)$ | $0.8125(10^6)$ | $1.236(10^6)$ |
| 3 | $25(100)$ | 72.5 | $\frac{1}{12}(25)(100^3)$ | $13.141(10^6)$ | $15.224(10^6)$ |

Thus,

$$I_{x'} = \Sigma (I_{x'})_i = 34.41(10^6) \text{ mm}^4 = 34.4(10^6) \text{ mm}^4 \quad \text{Ans}$$

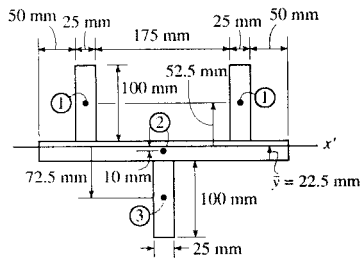
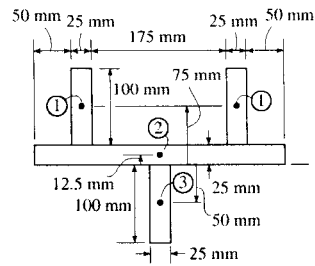

10-42. Determine the moment of inertia of the beam's cross-sectional area about the y axis.

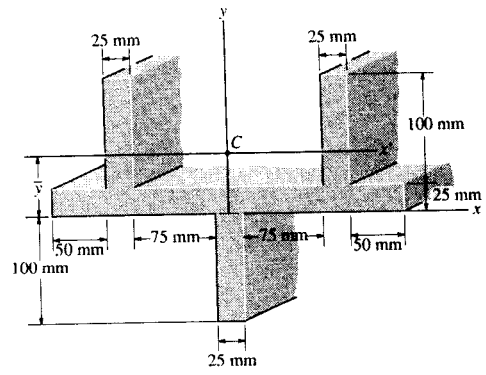

Moment of Inertia: The moment of inertia about the y' axis for each segment can be determined using the parallel-axis theorem $I_{y'} = \bar{I}_{y'} + Ad_x^2$.

| Segment | A_i (mm ²) | $(d_x)_i$ (mm) | $(\bar{I}_{y'})_i$ (mm ⁴) | $(Ad_x^2)_i$ (mm ⁴) | $(I_{y'})_i$ (mm ⁴) |
|---------|--------------------------|----------------|---------------------------------------|---------------------------------|---------------------------------|
| 1 | $2[100(25)]$ | 100 | $\frac{1}{12}(100)(25^3)$ | $50.0(10^6)$ | $50.130(10^6)$ |
| 2 | $25(325)$ | 0 | $\frac{1}{12}(25)(325^3)$ | 0 | $71.519(10^6)$ |
| 3 | $100(25)$ | 0 | $\frac{1}{12}(100)(25^3)$ | 0 | $0.130(10^6)$ |

Thus,

$$I_{y'} = \Sigma(I_{y'})_i = 121.78(10^6) \text{ mm}^4 = 122(10^6) \text{ mm}^4 \quad \text{Ans}$$

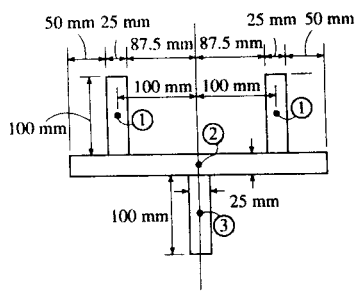

10-43. Determine the moment of inertia I_x of the shaded area about the x axis.

$$I_x = \left[\frac{1}{12}(6)(6)^3 + 6(6)(3)^2 \right] + \left[\frac{1}{36}(3)(6)^3 + \left(\frac{1}{2} \right)(3)(6)(2)^2 \right] + \left[\frac{1}{36}(9)(6)^3 + \frac{1}{2}(6)(9)(2)^2 \right]$$

$$I_x = 648 \text{ in}^4 \quad \text{Ans}$$

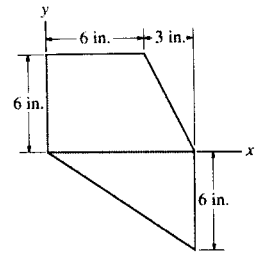

***10-44.** Determine the moment of inertia I_y of the shaded area about the y axis.

$$I_y = \left[\frac{1}{12}(6)(6)^3 + 6(6)(3)^2 \right] + \left[\frac{1}{36}(6)(3)^3 + \frac{1}{2}(6)(3)(6+1)^2 \right] + \left[\frac{1}{36}(6)(9)^3 + \frac{1}{2}(6)(9)(6)^2 \right] = 1971 \text{ in}^4 \quad \text{Ans}$$

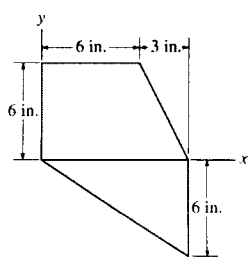

10-45. Locate the centroid \bar{y} of the channel's cross-sectional area, and then determine the moment of inertia with respect to the x' axis passing through the centroid.

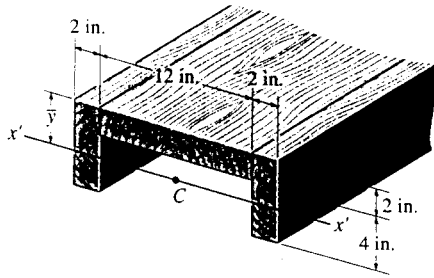

$$\bar{y} = \frac{\sum \bar{y}A}{\sum A} = \frac{(1)(12)(2) + 2[(3)(6)(2)]}{12(2) + 2(6)(2)}$$

$$= 2 \text{ in.} \quad \text{Ans}$$

$$\bar{I}_{x'} = \left[\frac{1}{12}(12)(2)^3 + 12(2)(1)^2 \right] + 2 \left[\frac{1}{12}(2)(6)^3 + 6(2)(3-2)^2 \right]$$

$$\bar{I}_{x'} = 128 \text{ in}^4 \quad \text{Ans}$$

10-46. Determine the moments of inertia I_x and I_y of the shaded area.

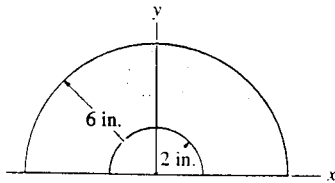

$$I_x = I_y = \frac{\pi(6)^4}{8} - \frac{\pi(2)^4}{8}$$

$$= 503 \text{ in}^4 \quad \text{Ans}$$

10-47. Determine the moment of inertia of the parallelogram about the x' axis, which passes through the centroid C of the area.

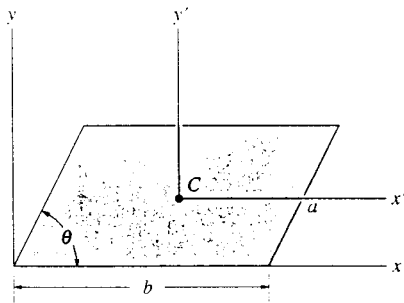

$$h = a \sin \theta$$

$$\bar{I}_{x'} = \frac{1}{12}bh^3 = \frac{1}{12}(b)(a \sin \theta)^3 = \frac{1}{12}a^3b \sin^3 \theta \quad \text{Ans}$$

*10-48. Determine the moment of inertia of the parallelogram about the y' axis, which passes through the centroid C of the area.

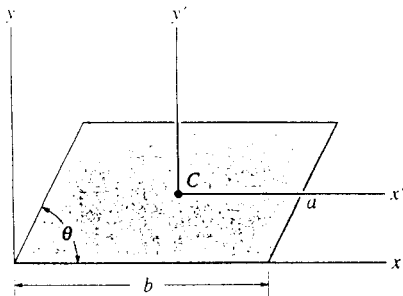

$$\bar{x} = a \cos \theta + \frac{b - a \cos \theta}{2} = \frac{1}{2}(a \cos \theta + b)$$

$$\bar{I}_{y'} = 2 \left[\frac{1}{36}(a \sin \theta)(a \cos \theta)^3 + \frac{1}{2}(a \sin \theta)(a \cos \theta) \left(\frac{b}{2} + \frac{a}{2} \cos \theta - \frac{2}{3} a \cos \theta \right)^2 \right]$$

$$+ \frac{1}{12}(a \sin \theta)(b - a \cos \theta)^3$$

$$= \frac{ab \sin \theta}{12} (b^2 + a^2 \cos^2 \theta) \quad \text{Ans}$$

10-49. An aluminum strut has a cross section referred to as a deep hat. Determine the location \bar{y} of the centroid of its area and the moment of inertia of the area about the x' axis. Each segment has a thickness of 10 mm.

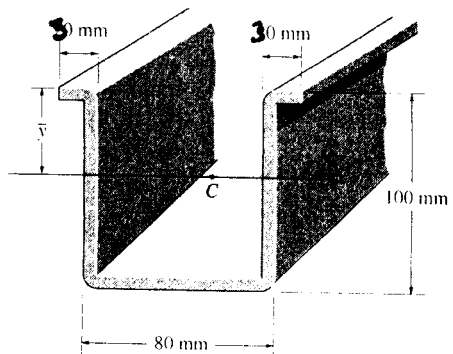

Centroid : The area of each segment and its respective centroid are tabulated below.

| Segment | A (mm^2) | \bar{y} (mm) | $\bar{y}A$ (mm^3) |
|----------|-----------------------|----------------|------------------------------|
| 1 | $40(10)$ | 5 | $2.00(10^3)$ |
| 2 | $20(100)$ | 50 | $100.0(10^3)$ |
| 3 | $60(10)$ | 95 | $57.0(10^3)$ |
| Σ | $3.00(10^3)$ | | $159.0(10^3)$ |

Thus,

$$\bar{y} = \frac{\Sigma \bar{y}A}{\Sigma A} = \frac{159.0(10^3)}{3.00(10^3)} = 53.0 \text{ mm} \quad \text{Ans}$$

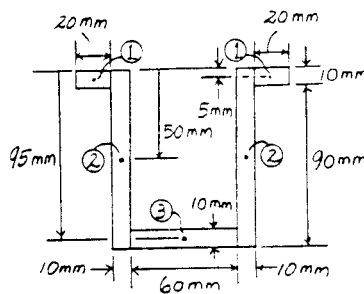

Moment of Inertia : The moment of inertia about the x' axis for each segment can be determined using the parallel-axis theorem $I_{x'} = I_x + Ad^2$.

| Segment | A_i (mm^2) | $(d_i)_i$ (mm) | $(\bar{I}_{x'})_i$ (mm^4) | $(Ad^2)_i$ (mm^4) | $(I_{x'})_i$ (mm^4) |
|---------|-------------------------|----------------|--------------------------------------|------------------------------|--------------------------------|
| 1 | $40(10)$ | 48.0 | $\frac{1}{12}(40)(10^3)$ | $0.9216(10^6)$ | $0.9249(10^6)$ |
| 2 | $20(100)$ | 3.00 | $\frac{1}{12}(20)(100^3)$ | $0.018(10^6)$ | $1.6847(10^6)$ |
| 3 | $60(10)$ | 42.0 | $\frac{1}{12}(60)(10^3)$ | $1.0584(10^6)$ | $1.0634(10^6)$ |

Thus,

$$I_{x'} = \Sigma (I_{x'})_i = 3.673(10^6) \text{ mm}^4 = 3.67(10^6) \text{ mm}^4 \quad \text{Ans}$$

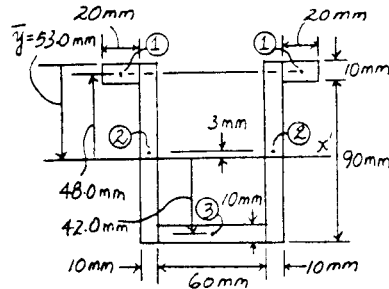

10-50. Determine the moment of inertia of the beam's cross-sectional area with respect to the x' axis passing through the centroid C of the cross section. Neglect the size of the corner welds at A and B for the calculation, $\bar{y} = 104.3 \text{ mm}$.

Moment of Inertia: The moment of inertia about the x' axis for each segment can be determined using the parallel-axis theorem $I_{x'} = \bar{I}_x + Ad^2$.

| Segment | $A_i \text{ (mm}^2\text{)}$ | $(d_i)_i \text{ (mm)}$ | $(\bar{I}_x)_i \text{ (mm}^4\text{)}$ | $(Ad^2)_i \text{ (mm}^4\text{)}$ | $(I_{x'})_i \text{ (mm}^4\text{)}$ |
|---------|-----------------------------|------------------------|---------------------------------------|----------------------------------|------------------------------------|
| 1 | $\pi(17.5^2)$ | 113.2 | $\frac{\pi}{4}(17.5^4)$ | $12.329(10^6)$ | $12.402(10^6)$ |
| 2 | $15(150)$ | 20.7 | $\frac{1}{12}(15)(150^3)$ | $0.964(10^6)$ | $5.183(10^6)$ |
| 3 | $\pi(25^2)$ | 79.3 | $\frac{\pi}{4}(25^4)$ | $12.347(10^6)$ | $12.654(10^6)$ |

Thus,

$$I_{x'} = \Sigma(I_{x'})_i = 30.24(10^6) \text{ mm}^4 = 30.2(10^6) \text{ mm}^4 \quad \text{Ans}$$

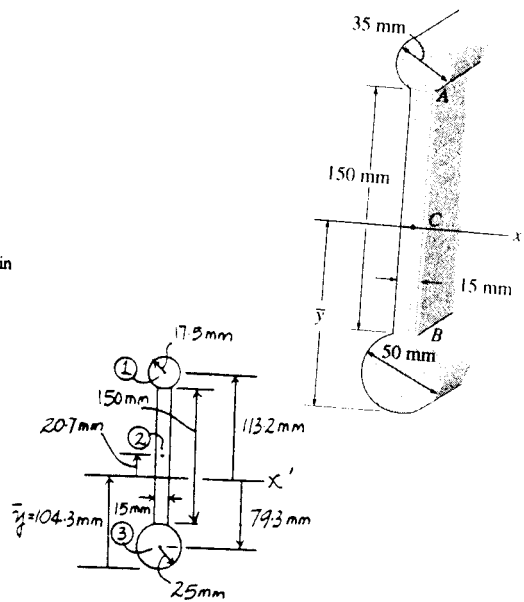

10-51. Determine the location \bar{y} of the centroid of the channel's cross-sectional area and then calculate the moment of inertia of the area about this axis.

Centroid: The area of each segment and its respective centroid are tabulated below.

| Segment | $A \text{ (mm}^2\text{)}$ | $\bar{y} \text{ (mm)}$ | $\bar{y}A \text{ (mm}^3\text{)}$ |
|----------|---------------------------|------------------------|----------------------------------|
| 1 | $100(250)$ | 125 | $3.125(10^6)$ |
| 2 | $250(50)$ | 25 | $0.3125(10^6)$ |
| Σ | $37.5(10^3)$ | | $3.4375(10^6)$ |

Thus,

$$\bar{y} = \frac{\Sigma \bar{y}A}{\Sigma A} = \frac{3.4375(10^6)}{37.5(10^3)} = 91.67 \text{ mm} = 91.7 \text{ mm} \quad \text{Ans}$$

Moment of Inertia: The moment of inertia about the x' axis for each segment can be determined using the parallel-axis theorem $I_{x'} = \bar{I}_x + Ad^2$.

| Segment | $A_i \text{ (mm}^2\text{)}$ | $(d_i)_i \text{ (mm)}$ | $(\bar{I}_x)_i \text{ (mm}^4\text{)}$ | $(Ad^2)_i \text{ (mm}^4\text{)}$ | $(I_{x'})_i \text{ (mm}^4\text{)}$ |
|---------|-----------------------------|------------------------|---------------------------------------|----------------------------------|------------------------------------|
| 1 | $100(250)$ | 33.33 | $\frac{1}{12}(100)(250^3)$ | $27.778(10^6)$ | $157.99(10^6)$ |
| 2 | $250(50)$ | 66.67 | $\frac{1}{12}(250)(50^3)$ | $55.556(10^6)$ | $58.16(10^6)$ |

Thus,

$$I_{x'} = \Sigma(I_{x'})_i = 216.15(10^6) \text{ mm}^4 = 216(10^6) \text{ mm}^4 \quad \text{Ans}$$

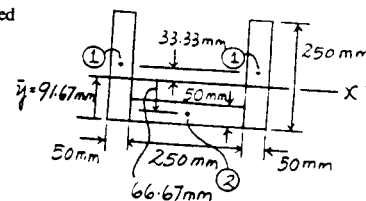
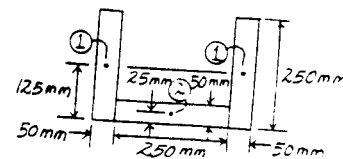
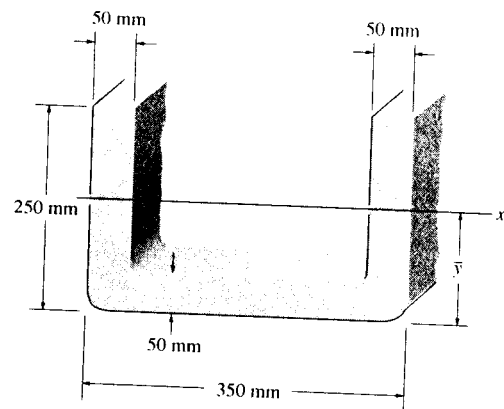

*10-52. Determine the radius of gyration k_x for the column's cross-sectional area.

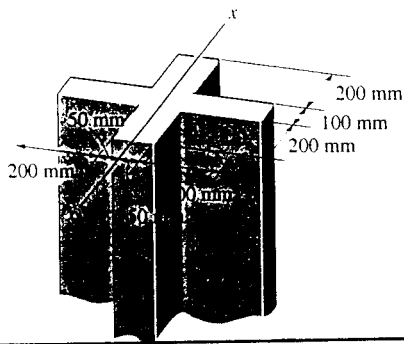

$$I_x = \frac{1}{12}(500)(100)^3 + 2\left[\frac{1}{12}(100)(200)^3 + (100)(200)(150)^2\right]$$

$$= 1.075(10^9) \text{ mm}^4$$

$$k_x = \sqrt{\frac{1.075(10^9)}{90(10^3)}} = 109 \text{ mm} \quad \text{Ans}$$

10-53. Determine the moments of inertia of the triangular area about the x' and y' axes, which pass through the centroid C of the area.

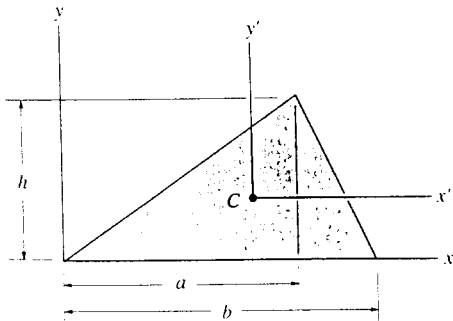

$$I_{x'} = \frac{1}{36}(a)h^3 + \frac{1}{36}(b-a)h^3 = \frac{1}{36}bh^3 \quad \text{Ans}$$

$$\bar{x} = \frac{\sum \bar{x}A}{\sum A} = \frac{\frac{2}{3}a\left[\frac{1}{2}h(a)\right] + \left[a + \frac{b-a}{3}\right]\left[\frac{1}{2}h(b-a)\right]}{\frac{1}{2}h(a) + \frac{1}{2}h(b-a)} = \frac{b+a}{3}$$

$$I_{y'} = \frac{1}{36}ha^3 + \frac{1}{2}ha\left(\frac{b-a}{3} - \frac{2}{3}a\right)^2 + \frac{1}{36}h(b-a)^3 + \frac{1}{2}h(b-a)\left(a + \frac{b-a}{3} - \frac{b-a}{3}\right)^2$$

$$= \frac{1}{36}hb(b^2 - ab + a^2) \quad \text{Ans}$$

*10-54. Determine the product of inertia of the shaded portion of the parabola with respect to the x and y axes.

Differential Element: Here, $x = \sqrt{50y}^{\frac{1}{2}}$. The area of the differential element parallel to the x axis is $dA = 2xdy = 2\sqrt{50y}^{\frac{1}{2}}dy$. The coordinates of the centroid for this element are $\bar{x} = 0$, $\bar{y} = y$. Then the product of inertia for this element is

$$dI_{xy} = d\bar{I}_{x'y'} + dA\bar{x}\bar{y}$$

$$= 0 + (2\sqrt{50y}^{\frac{1}{2}}dy)(0)(y)$$

$$= 0$$

Product of Inertia: Performing the integration, we have

$$I_{xy} = \int dI_{xy} = 0 \quad \text{Ans}$$

Note: By inspection, $I_{xy} = 0$ since the shaded area is symmetrical about the y axis.

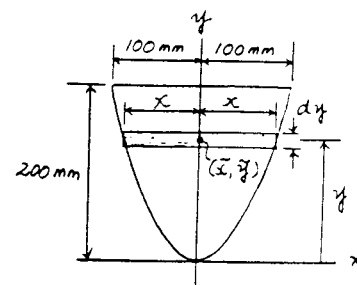
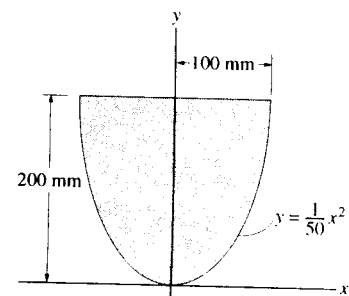

10-55. Determine the product of inertia of the shaded area with respect to the x and y axes.

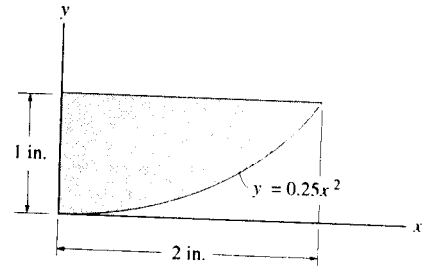

Differential Element : Here, $x = 2y^{1/2}$. The area of the differential element parallel to the x axis is $dA = xdy = 2y^{1/2}dy$. The coordinates of the centroid for this element are $\bar{x} = \frac{x}{2} = y^{1/2}$, $\bar{y} = y$. Then the product of inertia for this element is

$$\begin{aligned} dI_{xy} &= d\bar{I}_{xy} + dA\bar{x}\bar{y} \\ &= 0 + (2y^{1/2}dy)(y^{1/2})(y) \\ &= 2y^2 dy \end{aligned}$$

Product of Inertia : Performing the integration, we have

$$I_{xy} = \int dI_{xy} = \int_0^{1 \text{ in.}} 2y^2 dy = \frac{2}{3}y^3 \Big|_0^{1 \text{ in.}} = 0.667 \text{ in}^4 \quad \text{Ans}$$

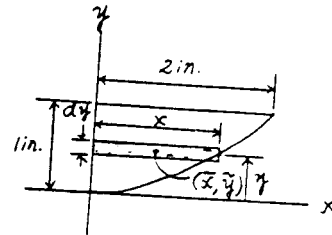

*10-56. Determine the product of inertia of the shaded area of the ellipse with respect to the x and y axes.

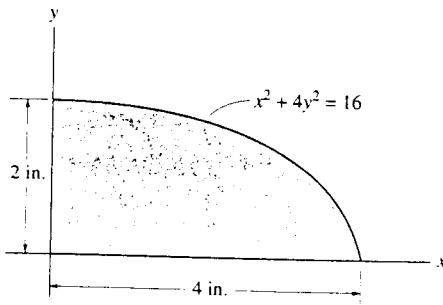

$$I_{xy} = \int_A \bar{x}\bar{y} dA = \int_0^4 \left(\frac{y}{2}\right)(xy) dx$$

$$= \frac{1}{2} \int_0^4 y^2 x dx$$

$$= \frac{1}{2} \int_0^4 \frac{1}{4}(16 - x^2)x dx$$

$$= \frac{1}{8} \int_0^4 (16x - x^3) dx$$

$$= \frac{1}{8} \left[8x^2 - \frac{1}{4}x^4 \right]_0^4$$

$$I_{xy} = 8 \text{ in}^4 \quad \text{Ans}$$

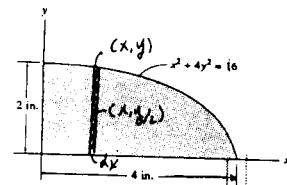

10-57. Determine the product of inertia of the parabolic area with respect to the x and y axes.

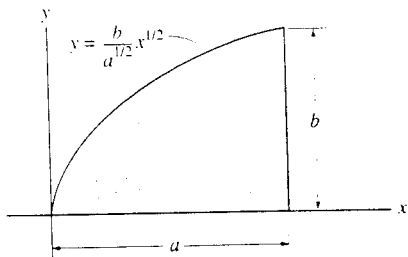

$$\bar{x} = x$$

$$\bar{y} = \frac{y}{2}$$

$$dA = y \, dx$$

$$dI_{xy} = \frac{xy^2}{2} \, dx$$

$$I_{xy} = \int dI_{xy}$$

$$= \int_0^a \frac{1}{2} \left(\frac{b^2}{a} \right) x^2 \, dx$$

$$= \frac{1}{6} \left[\left(\frac{b^2}{a} \right) x^3 \right]_0^a$$

$$= \frac{1}{6} a^2 b^2 \quad \text{Ans}$$

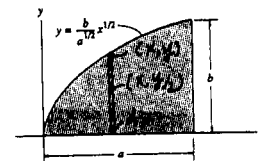

10-58. Determine the product of inertia of the shaded area with respect to the x and y axes.

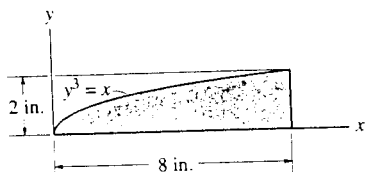

$$\bar{x} = x$$

$$\bar{y} = \frac{y}{2}$$

$$dA = y \, dx$$

$$dI_{xy} = \frac{xy^2}{2} \, dx$$

$$I_{xy} = \int dI_{xy}$$

$$= \frac{1}{2} \int_0^8 x^{5/3} \, dx$$

$$= \frac{1}{2} \left(\frac{3}{8} \right) \left[x^{8/3} \right]_0^8$$

$$= 48 \, \text{in}^4 \quad \text{Ans}$$

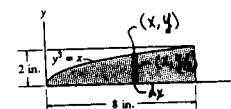

10-59. Determine the product of inertia of the shaded area with respect to the x and y axes.

Differential Element : Here, $y = \sqrt{4-x^2}$. The area of the differential element parallel to the y axis is $dA = y dx = \sqrt{4-x^2} dx$. The coordinates of the centroid for this element are $\bar{x} = x$, $\bar{y} = \frac{y}{2} = \frac{1}{2}\sqrt{4-x^2}$. Then the product of inertia for this element is

$$\begin{aligned} dI_{xy} &= d\bar{I}_{xy} + dA\bar{x}\bar{y} \\ &= 0 + (\sqrt{4-x^2} dx) (x) \left(\frac{1}{2}\sqrt{4-x^2}\right) \\ &= \frac{1}{2}(4x-x^3) dx \end{aligned}$$

Product of Inertia : Performing the integration, we have

$$\begin{aligned} I_{xy} &= \int dI_{xy} = \frac{1}{2} \int_0^{2\text{in.}} (4x-x^3) dx \\ &= \frac{1}{2} \left(2x^2 - \frac{x^4}{4} \right) \Big|_0^{2\text{in.}} = 2.00 \text{ in}^4 \quad \text{Ans} \end{aligned}$$

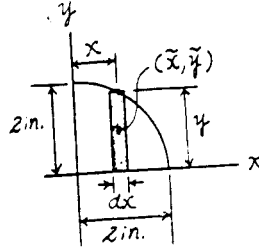
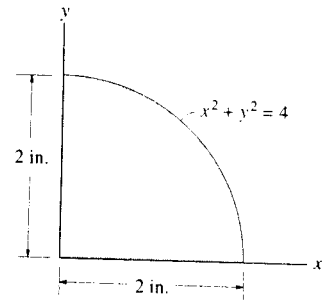

*10-60. Determine the product of inertia of the shaded area with respect to the x and y axes.

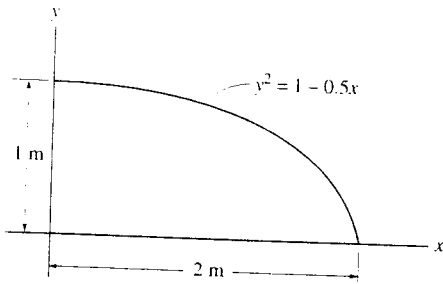

$$\bar{x} = x$$

$$\bar{y} = \frac{y}{2}$$

$$dA = y dx$$

$$dI_{xy} = \frac{xy^2}{2} dx$$

$$I_{xy} = \int dI_{xy}$$

$$= \int_0^2 \frac{1}{2}(x - 0.5x^2) dx$$

$$= \frac{1}{2} \left[\frac{x^2}{2} - \frac{1}{6}x^3 \right]_0^2$$

$$= 0.333 \text{ m}^4 \quad \text{Ans}$$

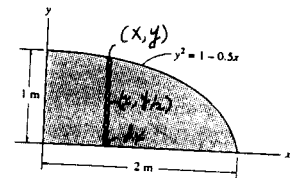

10-61. Determine the product of inertia of the shaded area with respect to the x and y axes.

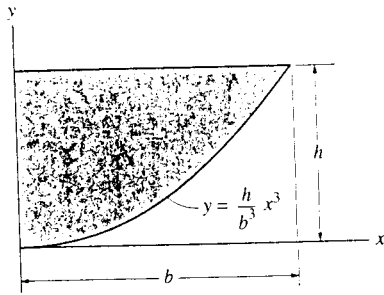

$$\bar{x} = x$$

$$\bar{y} = \frac{y}{2}$$

$$dA = x \, dy$$

$$dI_{xy} = \frac{x^2 y}{2} \, dy$$

$$I_{xy} = \int dI_{xy}$$

$$= \int_0^h \frac{1}{2} \left(\frac{b}{h^{1/3}} \right)^2 y^{5/3} \, dy$$

$$= \frac{1}{2} \left[\left(\frac{b^2}{h^{2/3}} \right) \left(\frac{3}{8} \right) y^{8/3} \right]_0^h$$

$$= \frac{3}{16} b^2 h^2 \quad \text{Ans}$$

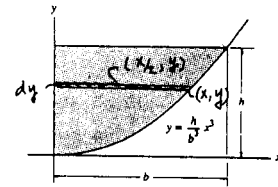

*10-62. Determine the product of inertia of the shaded area with respect to the x and y axes.

Differential Element: The area of the differential element parallel to the y axis is $dA = y \, dx = (a^{\frac{1}{2}} - x^{\frac{1}{2}})^2 \, dx$. The coordinates of the centroid for this element are $\bar{x} = x$, $\bar{y} = \frac{y}{2} = \frac{1}{2}(a^{\frac{1}{2}} - x^{\frac{1}{2}})^2$. Then the product of inertia for this element is

$$\begin{aligned} dI_{xy} &= d\bar{I}_{x'y'} + dA\bar{x}\bar{y} \\ &= 0 + \left[(a^{\frac{1}{2}} - x^{\frac{1}{2}})^2 \, dx \right] \left(x \right) \left[\frac{1}{2} (a^{\frac{1}{2}} - x^{\frac{1}{2}})^2 \right] \\ &= \frac{1}{2} (x^3 + a^2 x + 6ax^2 - 4a^{\frac{3}{2}} x^{\frac{3}{2}} - 4a^{\frac{1}{2}} x^{\frac{5}{2}}) \, dx \end{aligned}$$

Product of Inertia: Performing the integration, we have

$$\begin{aligned} I_{xy} &= \int dI_{xy} = \frac{1}{2} \int_0^a (x^3 + a^2 x + 6ax^2 - 4a^{\frac{3}{2}} x^{\frac{3}{2}} - 4a^{\frac{1}{2}} x^{\frac{5}{2}}) \, dx \\ &= \frac{1}{2} \left(\frac{x^4}{4} + \frac{a^2 x^2}{2} + 2ax^3 - \frac{8}{5} a^{\frac{3}{2}} x^{\frac{5}{2}} - \frac{8}{7} a^{\frac{1}{2}} x^{\frac{7}{2}} \right) \Big|_0^a \\ &= \frac{a^4}{280} \end{aligned}$$

Ans

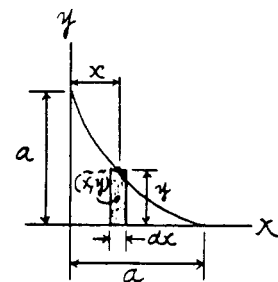
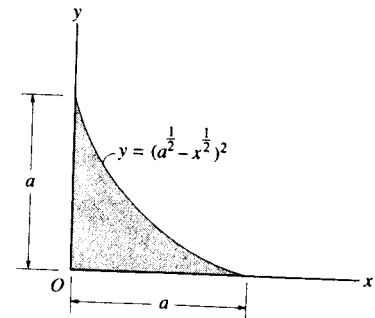

10-63. Determine the product of inertia of the shaded area with respect to the x and y axes.

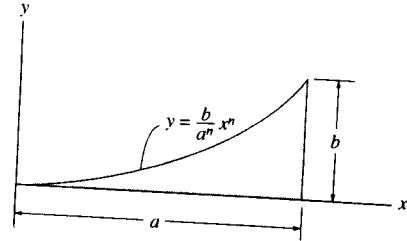

$$dI_{xy} = d\bar{I}_{xy} + \bar{x}\bar{y}dA$$

$$I_{xy} = 0 + \int_0^a (x) \left(\frac{y}{2}\right) (y dx) = \frac{1}{2} \int_0^a \left(\frac{b^2}{a^{2n}}\right) x^{2n+1} dx$$

$$= \left(\frac{b^2}{2a^{2n}}\right) \left(\frac{1}{2n+2}\right) x^{2n+2} \Big|_0^a = \frac{b^2 a^{2n+2}}{4(n+1) a^{2n}}$$

$$= \frac{a^2 b^2}{4(n+1)} \quad \text{Ans}$$

*10-64. Determine the product of inertia of the shaded area with respect to the x and y axes.

Differential Element: Here, $x = \frac{y^2}{2}$. The area of the differential element parallel to the x axis is $dA = x dy = \frac{y^2}{2} dy$. The coordinates of the centroid for this element are $\bar{x} = \frac{x}{2} = \frac{y^2}{4}$, $\bar{y} = y$. Then the product of inertia for this element is

$$\begin{aligned} dI_{xy} &= d\bar{I}_{xy} + dA\bar{x}\bar{y} \\ &= 0 + \left(\frac{y^2}{2} dy\right) \left(\frac{y^2}{4}\right) (y) \\ &= \frac{1}{8} y^5 dy \end{aligned}$$

Product of Inertia: Performing the integration, we have

$$I_{xy} = \int dI_{xy} = \frac{1}{8} \int_0^{2m} y^5 dy = \frac{1}{48} y^6 \Big|_0^{2m} = 1.33 \text{ m}^4 \quad \text{Ans}$$

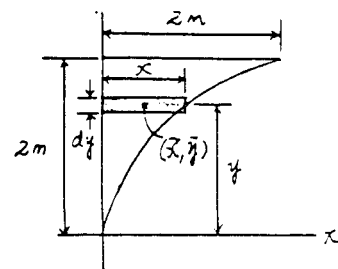
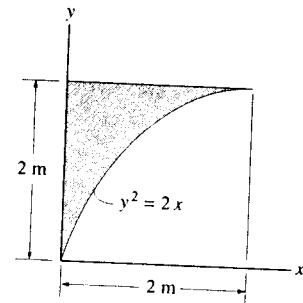

- 10-65. Determine the product of inertia of the shaded area with respect to the x and y axes. Use Simpson's rule to evaluate the integral.

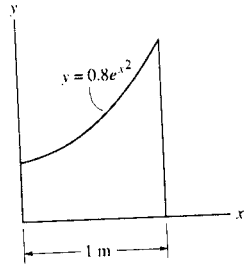

$$\bar{x} = x$$

$$\bar{y} = \frac{y}{2}$$

$$dA = y dx$$

$$dI_{xy} = \frac{xy^2}{2} dx$$

$$I_{xy} = \int dI_{xy}$$

$$= \int_0^1 \frac{1}{2} x (0.8 e^{x^2})^2 dx$$

$$= 0.32 \int_0^1 x e^{2x^2} dx$$

$$= 0.511 \text{ m}^4 \quad \text{Ans}$$

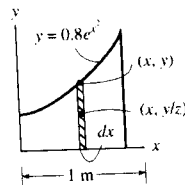

- 10-66. Determine the product of inertia of the thin strip of area with respect to the x and y axes. The strip is oriented at an angle θ from the x axis. Assume that $t \ll l$.

$$I_{xy} = \int_A xy dA = \int_0^l (s \cos \theta)(s \sin \theta) t ds = \sin \theta \cos \theta t \int_0^l s^2 ds$$

$$= \frac{1}{6} l^3 t \sin 2\theta$$

Ans

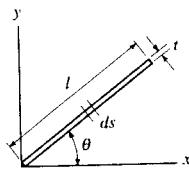
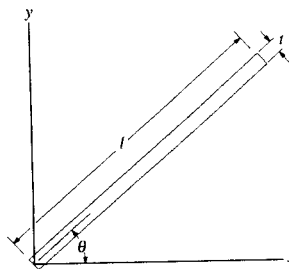

10-67. Determine the product of inertia of the beam's cross-sectional area with respect to the x and y axes that have their origin located at the centroid C .

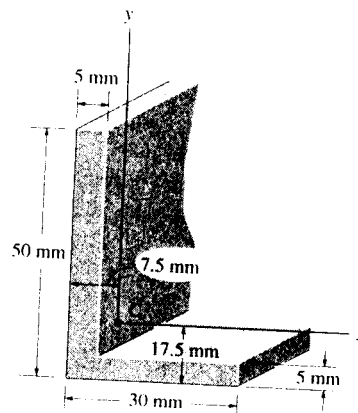

Product of Inertia: The area for each segment, its centroid and product of inertia with respect to x and y axes are tabulated below.

| Segment | A_i (mm^2) | $(d_x)_i$ (mm) | $(d_y)_i$ (mm) | $(I_{xy})_i$ (mm^4) |
|---------|-------------------------|----------------|----------------|--------------------------------|
| 1 | 50(5) | -5 | 7.5 | $-9.375(10^3)$ |
| 2 | 25(5) | 10 | -15 | $-18.75(10^3)$ |

Thus,

$$I_{xy} = \Sigma(I_{xy})_i = -28.125(10^3) \text{ mm}^4 = -28.1(10^3) \text{ mm}^4 \quad \text{Ans}$$

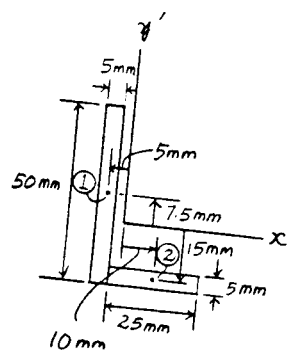

*10-68. Determine the product of inertia of the beam's cross-sectional area with respect to the x and y axes.

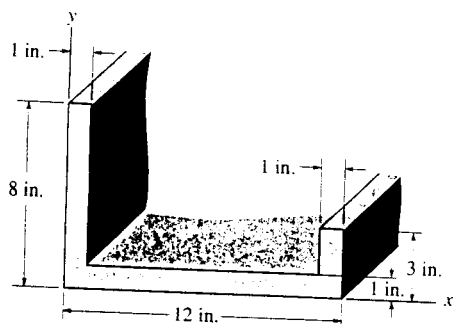

$$I_{xy} = 0.5(4)(8)(1) + 6(0.5)(10)(1) + 11.5(1.5)(3)(1)$$

$$= 97.8 \text{ in}^4 \quad \text{Ans}$$

10-69. Determine the product of inertia of the cross-sectional area with respect to the x and y axes that have their origin located at the centroid C .

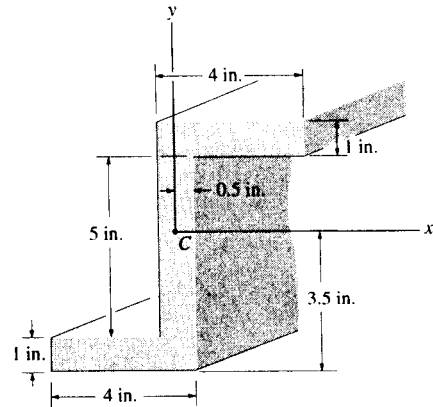

Product of Inertia: The area for each segment, its centroid and product of inertia with respect to x and y axes are tabulated below.

| Segment | A_i (in ²) | $(d_x)_i$ (in.) | $(d_y)_i$ (in.) | $(I_{xy})_i$ (in ⁴) |
|---------|--------------------------|-----------------|-----------------|---------------------------------|
| 1 | 3(1) | 2 | 3 | 18.0 |
| 2 | 7(1) | 0 | 0 | 0 |
| 3 | 3(1) | -2 | -3 | 18.0 |

Thus,

$$I_{xy} = \Sigma (I_{xy})_i = 36.0 \text{ in}^4 \quad \text{Ans}$$

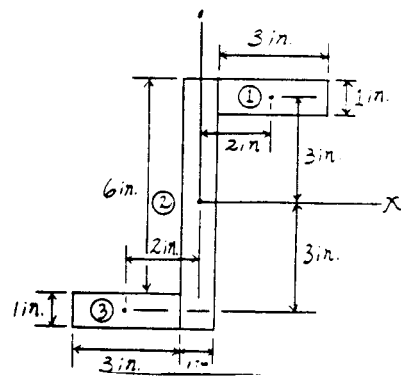

10-70. Determine the product of inertia of the parallelogram with respect to the x and y axes.

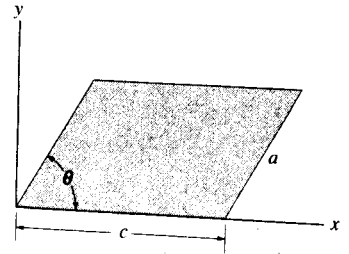

Product of Inertia of the Triangle: The product of inertia with respect to x and y axes can be determined by integration. The area of the differential element parallel to y axis is dA

$= y dx = \left(h + \frac{h}{b}x\right) dx$ [Fig. (a)]. The coordinates of the centroid for this element are $\bar{x} = -x$, $\bar{y} = \frac{y}{2} = \frac{1}{2}\left(h + \frac{h}{b}x\right)$. Then the product of inertia for this element is

$$\begin{aligned} dI_{xy} &= d\bar{I}_{x'y'} + dA\bar{x}\bar{y} \\ &= 0 + \left[\left(h + \frac{h}{b}x\right) dx\right](-x)\left[\frac{1}{2}\left(h + \frac{h}{b}x\right)\right] \\ &= -\frac{1}{2}\left(h^2x + \frac{h^2}{b^2}x^3 + \frac{2h^2}{b}x^2\right) dx \end{aligned}$$

Performing the integration, we have

$$I_{xy} = \int dI_{xy} = -\frac{1}{2} \int_{-b}^0 \left(h^2x + \frac{h^2}{b^2}x^3 + \frac{2h^2}{b}x^2\right) dx = -\frac{b^2h^2}{24}$$

The product of inertia with respect to centroidal axes, x' and y' , can be determined by applying Eq. 10-8 [Fig. (b) or (c)].

$$\begin{aligned} I_{xy} &= \bar{I}_{x'y'} + A d_x d_y \\ -\frac{b^2h^2}{24} &= \bar{I}_{x'y'} + \frac{1}{2}bh\left(-\frac{b}{3}\right)\left(\frac{h}{3}\right) \\ \bar{I}_{x'y'} &= \frac{b^2h^2}{72} \end{aligned}$$

Here, $b = a \cos \theta$ and $h = a \sin \theta$. Then, $\bar{I}_{x'y'} = \frac{a^2 b^2 \sin^2 \theta \cos^2 \theta}{72}$.

Product of inertia of the parallelogram [Fig. (d)] with respect to centroidal x' and y' axes, is

$$\begin{aligned} I_{x'y'} &= 2 \left[\frac{a^4 \cos^2 \theta \sin^2 \theta}{72} + \frac{1}{2}(a \sin \theta)(a \cos \theta) \left(\frac{3c - a \cos \theta}{6}\right) \left(\frac{a \sin \theta}{6}\right) \right] \\ &= \frac{a^3 c \sin^2 \theta \cos \theta}{12} \end{aligned}$$

The product of inertia of the parallelogram [Fig. (d)] about x and y axes is

$$\begin{aligned} I_{xy} &= \bar{I}_{x'y'} + A d_x d_y \\ &= \frac{a^3 c \sin^2 \theta \cos \theta}{12} + (a \sin \theta)(c) \left(\frac{c + a \cos \theta}{2}\right) \left(\frac{a \sin \theta}{2}\right) \\ &= \frac{a^2 c \sin^2 \theta}{12} (4a \cos \theta + 3c) \quad \text{Ans} \end{aligned}$$

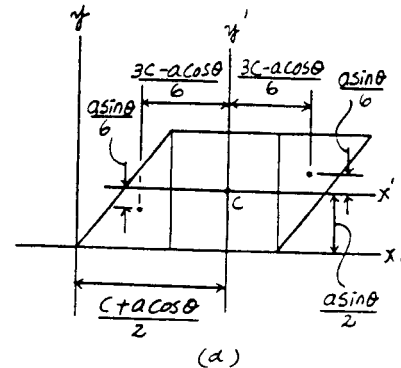
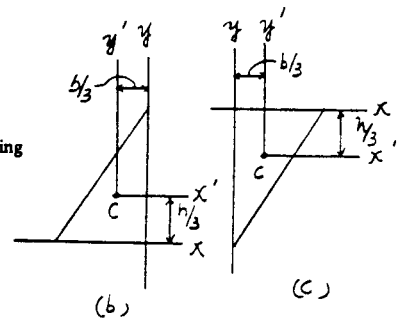
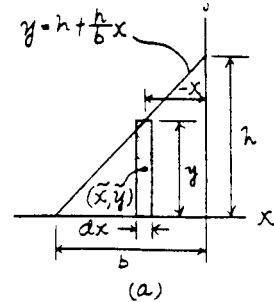

10-71. Determine the product of inertia of the cross-sectional area with respect to the x and y axes.

Product of Inertia: The area for each segment, its centroid and product of inertia with respect to x and y axes are tabulated below.

| Segment | A_i (mm ²) | $(d_x)_i$ (mm) | $(d_y)_i$ (mm) | $(I_{xy})_i$ (mm ⁴) |
|---------|--------------------------|----------------|----------------|---------------------------------|
| 1 | 100(20) | 60 | 410 | 49.2(10 ⁶) |
| 2 | 840(20) | 0 | 0 | 0 |
| 3 | 100(20) | -60 | -410 | 49.2(10 ⁶) |

Thus,

$$I_{xy} = \Sigma(I_{xy})_i = 98.4(10^6)\text{mm}^4 \quad \text{Ans}$$

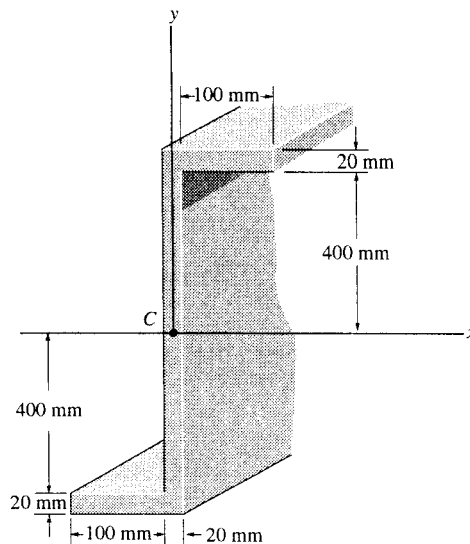
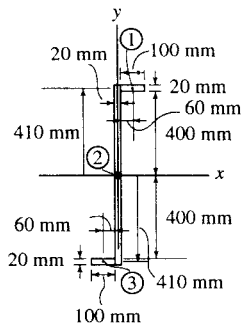

***10-72.** Determine the product of inertia of the beam's cross-sectional area with respect to the x and y axes that have their origin located at the centroid C .

$$I_{xy} = 5(1)(5.5)(-2) + 5(1)(-5.5)(2)$$

$$= -110 \text{ in}^4 \quad \text{Ans}$$

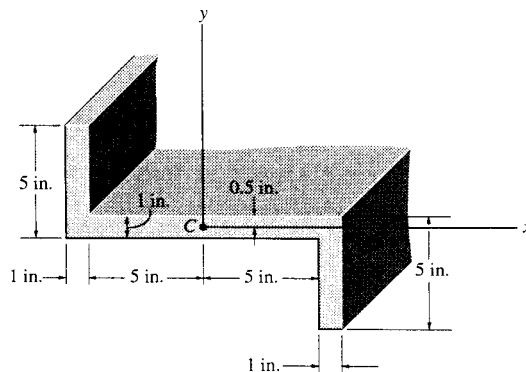

10-73. Determine the product of inertia for the angle with respect to the x and y axes passing through the centroid C . Assume all corners to be square.

Centroid:

$$\bar{x} = \frac{\Sigma \bar{x}A}{\Sigma A} = \frac{0.125(0.25)(3) + 1.625(0.25)(2.75)}{0.25(3) + 0.25(2.75)} = 0.8424 \text{ in}$$

$$\bar{y} = \frac{\Sigma \bar{y}A}{\Sigma A} = \frac{1.5(0.25)(3) + 0.125(0.25)(2.75)}{0.25(3) + 0.25(2.75)} = 0.8424 \text{ in}$$

Product of inertia about x and y axes:

$$I_{xy} = 0.25(3)(0.7174)(0.6576) + 0.25(2.75)(-0.7826)(-0.7174)$$

$$= 0.740 \text{ in}^4 \quad \text{Ans}$$

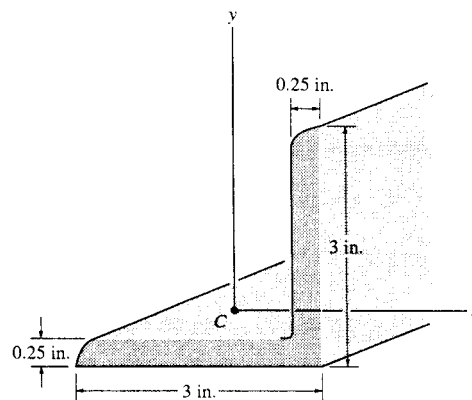

10-74. Determine the product of inertia for the beam's cross-sectional area with respect to the u and v axes.

Moments of inertia I_x and I_y .

$$I_x = \frac{1}{12}(300)(400)^3 - \frac{1}{12}(280)(360)^3 = 511.36(10^6) \text{ mm}^4$$

$$I_y = 2\left[\frac{1}{12}(20)(300)^3\right] + \frac{1}{12}(360)(20)^3 = 90.24(10^6) \text{ mm}^4$$

The section is symmetric about both x and y axes; therefore $I_{xy} = 0$.

$$\begin{aligned} I_{uv} &= \frac{I_x - I_y}{2} \sin 2\theta + I_{xy} \cos 2\theta \\ &= \left(\frac{511.36 - 90.24}{2} \sin 40^\circ + 0 \cos 40^\circ \right) 10^6 \\ &= 135(10^6) \text{ mm}^4 \quad \text{Ans} \end{aligned}$$

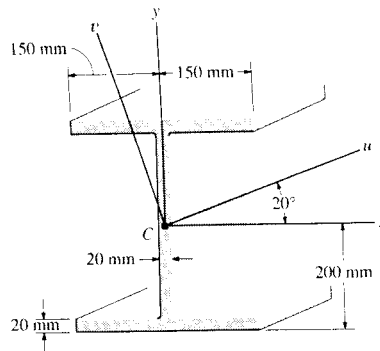

10-75. Determine the moments of inertia I_u and I_v of the cross-sectional area.

Moment and Product of Inertia about x and y Axes: Since the shaded area is symmetrical about the y axis, $I_{xy} = 0$.

$$\begin{aligned} I_x &= \frac{1}{12}(40)(200)^3 + 40(200)(120^2) + \frac{1}{12}(200)(40)^3 \\ &= 142.93(10^6) \text{ mm}^4 \end{aligned}$$

$$I_y = \frac{1}{12}(200)(40)^3 + \frac{1}{12}(40)(200)^3 = 27.73(10^6) \text{ mm}^4$$

Moment of Inertia about the Inclined u and v Axes: Applying Eq. 10-9 with $\theta = -30^\circ$, we have

$$\begin{aligned} I_u &= \frac{I_x + I_y}{2} + \frac{I_x - I_y}{2} \cos 2\theta - I_{xy} \sin 2\theta \\ &= \left(\frac{142.93 + 27.73}{2} + \frac{142.93 - 27.73}{2} \cos(-60^\circ) - 0[\sin(-60^\circ)] \right) (10^6) \\ &= 114(10^6) \text{ mm}^4 \quad \text{Ans} \end{aligned}$$

$$\begin{aligned} I_v &= \frac{I_x + I_y}{2} - \frac{I_x - I_y}{2} \cos 2\theta + I_{xy} \sin 2\theta \\ &= \left(\frac{142.93 + 27.73}{2} - \frac{142.93 - 27.73}{2} \cos(-60^\circ) - 0[\sin(-60^\circ)] \right) (10^6) \\ &= 56.5(10^6) \text{ mm}^4 \quad \text{Ans} \end{aligned}$$

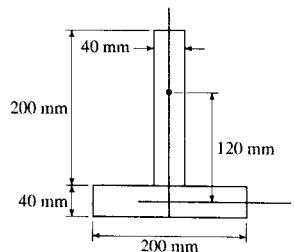
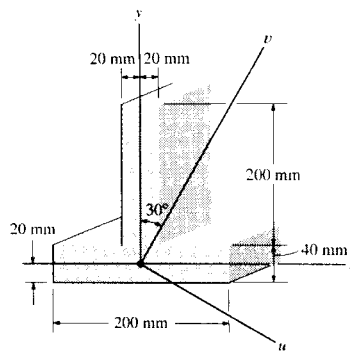

***10-76.** Determine the distance \bar{y} to the centroid of the area and then calculate the moments of inertia I_u and I_v of the channel's cross-sectional area. The u and v axes have their origin at the centroid C . For the calculation, assume all corners to be square.

$$\bar{y} = \frac{300(10)(5) + 2[(50)(10)(35)]}{300(10) + 2(50)(10)} = 12.5 \text{ mm}$$

$$I_x = \left[\frac{1}{12}(300)(10)^3 + 300(10)(12.5 - 5)^2 \right] + 2 \left[\frac{1}{12}(10)(50)^3 + 10(50)(35 - 12.5)^2 \right] = 0.9083(10^6) \text{ mm}^4$$

$$I_y = \frac{1}{12}(10)(300)^3 + 2 \left[\frac{1}{12}(50)(10)^3 + 50(10)(150 - 5)^2 \right] = 43.53(10^6) \text{ mm}^4$$

$$I_{xy} = 0 \quad (\text{By symmetry})$$

Ans

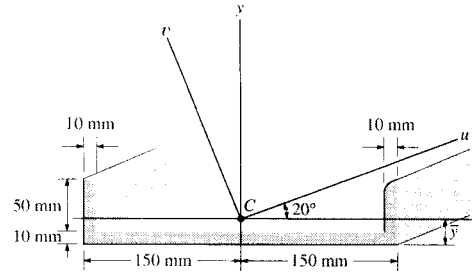

$$I_u = \frac{I_x + I_y}{2} + \frac{I_x - I_y}{2} \cos 2\theta - I_{xy} \sin 2\theta = \frac{0.9083(10^6) + 43.53(10^6)}{2} + \frac{0.9083(10^6) - 43.53(10^6)}{2} \cos 40^\circ - 0 = 5.89(10^6) \text{ mm}^4$$

Ans

$$I_v = \frac{I_x + I_y}{2} - \frac{I_x - I_y}{2} \cos 2\theta + I_{xy} \sin 2\theta = \frac{0.9083(10^6) + 43.53(10^6)}{2} - \frac{0.9083(10^6) - 43.53(10^6)}{2} \cos 40^\circ + 0 = 38.5(10^6) \text{ mm}^4$$

Ans

***10-77.** Determine the moments of inertia of the shaded area with respect to the u and v axes.

Moment and Product of Inertia about x and y Axes: Since the shaded area is symmetrical about the x axis, $I_{xy} = 0$.

$$I_x = \frac{1}{12}(1)(5^3) + \frac{1}{12}(4)(1^3) = 10.75 \text{ in}^4$$

$$I_y = \frac{1}{12}(1)(4^3) + 1(4)(2.5^2) + \frac{1}{12}(5)(1^3) = 30.75 \text{ in}^4$$

Moment of Inertia about the Inclined u and v Axes: Applying Eq. 10-9 with $\theta = 30^\circ$, we have

$$I_u = \frac{I_x + I_y}{2} + \frac{I_x - I_y}{2} \cos 2\theta - I_{xy} \sin 2\theta = \frac{10.75 + 30.75}{2} + \frac{10.75 - 30.75}{2} \cos 60^\circ - 0(\sin 60^\circ) = 15.75 \text{ in}^4$$

Ans

$$I_v = \frac{I_x + I_y}{2} - \frac{I_x - I_y}{2} \cos 2\theta + I_{xy} \sin 2\theta = \frac{10.75 + 30.75}{2} - \frac{10.75 - 30.75}{2} \cos 60^\circ + 0(\sin 60^\circ) = 25.75 \text{ in}^4$$

Ans

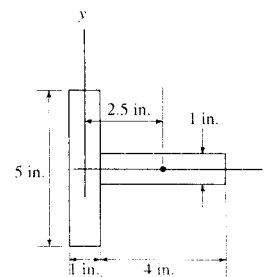
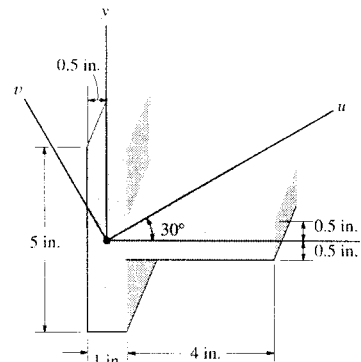

10-78. Determine the directions of the principal axes with origin located at point O , and the principal moments of inertia for the rectangular area about these axes.

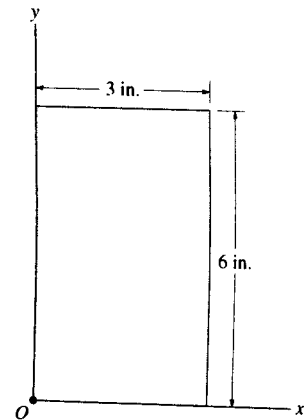

$$I_x = \frac{1}{12}(3)(6)^3 + (3)(6)(3)^2 = 216 \text{ in}^4$$

$$I_y = \frac{1}{12}(6)(3)^3 + (3)(6)(1.5)^2 = 54 \text{ in}^4$$

$$I_{xy} = \bar{x}\bar{y}A = (1.5)(3)(3)(6) = 81 \text{ in}^4$$

$$\tan 2\theta = \frac{-2I_{xy}}{I_x - I_y} = \frac{-2(81)}{216 - 54} = -1$$

$$\theta = -22.5^\circ \quad \text{Ans}$$

$$I_{max} = \frac{I_x + I_y}{2} \pm \sqrt{\left(\frac{I_x - I_y}{2}\right)^2 + I_{xy}^2} = \frac{216 + 54}{2} \pm \sqrt{\left(\frac{216 - 54}{2}\right)^2 + (81)^2}$$

$$I_{max} = 250 \text{ in}^4 \quad \text{Ans}$$

$$I_{min} = 20.4 \text{ in}^4 \quad \text{Ans}$$

10-79. Determine the moments of inertia I_u , I_v and the product of inertia I_{uv} of the beam's cross-sectional area. Take $\theta = 45^\circ$.

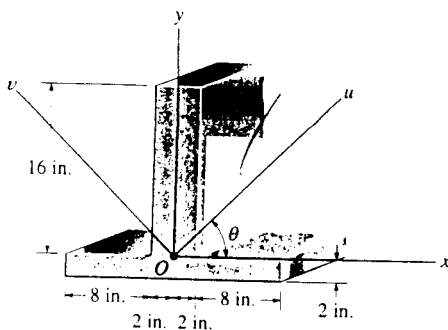

$$I_x = \frac{1}{12}(20)(2)^3 + 20(2)(1)^2 + \frac{1}{12}(4)(16)^3 + 4(16)(8)^2$$

$$= 5.515(10^3) \text{ in}^4$$

$$I_y = \frac{1}{12}(2)(20)^3 + \frac{1}{12}(16)(4)^3$$

$$= 1.419(10^3) \text{ in}^4$$

$$I_{xy} = 0$$

$$I_u = \frac{I_x + I_y}{2} + \frac{I_x - I_y}{2} \cos 2\theta - I_{xy} \sin 2\theta$$

$$= \frac{5.515 + 1.419}{2}(10^3) + \frac{5.515 - 1.419}{2}(10^3) \cos 90^\circ - 0$$

$$= 3.47(10^3) \text{ in}^4 \quad \text{Ans}$$

$$I_v = 3.47(10^3) \text{ in}^4 \quad \text{Ans}$$

$$I_{uv} = \frac{I_x - I_y}{2} \sin 2\theta + I_{xy} \cos 2\theta$$

$$= \frac{5.515 - 1.419}{2}(10^3) \sin 90^\circ + 0$$

$$= 2.05(10^3) \text{ in}^4 \quad \text{Ans}$$

***10-80.** Determine the directions of the principal axes with origin located at point O , and the principal moments of inertia of the area about these axes.

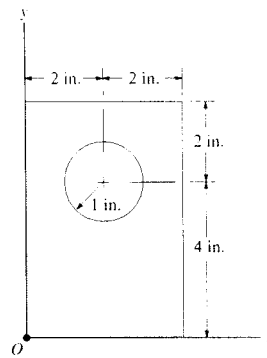

$$I_x = \left[\frac{1}{12}(4)(6)^3 + (4)(6)(3)^2 \right] - \left[\frac{1}{4}\pi(1)^4 + \pi(1)^2(4)^2 \right]$$

$$= 236.95 \text{ in}^4$$

$$I_y = \left[\frac{1}{12}(6)(4)^3 + (4)(6)(2)^2 \right] - \left[\frac{1}{4}\pi(1)^4 + \pi(1)^2(2)^2 \right]$$

$$= 114.65 \text{ in}^4$$

$$I_{xy} = [0 + (4)(6)(2)(3)] - [0 + \pi(1)(2)(4)] = 118.87 \text{ in}^4$$

$$\tan 2\theta_p = \frac{-I_{xy}}{I_x - I_y} = \frac{-118.87}{(236.95 - 114.65)}$$

$$\theta_p = -31.388^\circ; \quad 58.612^\circ$$

Thus,

$$\theta_{p1} = -31.4^\circ; \quad \theta_{p2} = 58.6^\circ \quad \text{Ans}$$

$$I_{max} = \frac{I_x + I_y}{2} \pm \sqrt{\left(\frac{I_x - I_y}{2}\right)^2 + I_{xy}^2}$$

$$= \frac{236.95 + 114.65}{2} \pm \sqrt{\left(\frac{236.95 - 114.65}{2}\right)^2 + (118.87)^2}$$

$$I_{max} = 309 \text{ in}^4 \quad \text{Ans}$$

$$I_{min} = 42.1 \text{ in}^4 \quad \text{Ans}$$

10-81. Determine the principal moments of inertia of the beam's cross-sectional area about the principal axes that have their origin located at the centroid C . Use the equations developed in Section 10-7. For the calculation, assume all corners to be square.

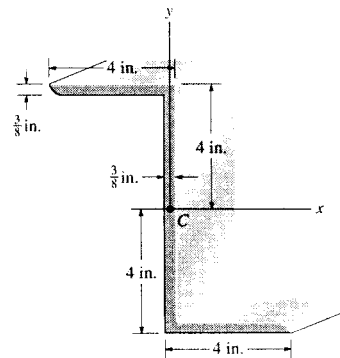

$$I_x = 2 \left[\frac{1}{12}(4)\left(\frac{3}{8}\right)^3 + 4\left(\frac{3}{8}\right)\left(4 - \frac{3}{16}\right)^2 \right] + \frac{1}{12}\left(\frac{3}{8}\right)\left(8 - \frac{6}{8}\right)^3$$

$$= 55.55 \text{ in}^4$$

$$I_y = 2 \left[\frac{1}{12}\left(\frac{3}{8}\right)\left(4 - \frac{3}{8}\right)^3 + \frac{3}{8}\left(4 - \frac{3}{8}\right)\left\{\left(\frac{4 - \frac{3}{8}}{2}\right) + \frac{3}{16}\right\}^2 \right]$$

$$+ \frac{1}{12}(8)\left(\frac{3}{8}\right)^3$$

$$= 13.89 \text{ in}^4$$

$$I_{xy} = \Sigma \bar{x}\bar{y}A$$

$$= -2[(1.813 + 0.1875)(3.813)(3.625)(0.375)] + 0$$

$$= -20.73 \text{ in}^4$$

$$I_{max/min} = \frac{I_x + I_y}{2} \pm \sqrt{\left(\frac{I_x - I_y}{2}\right)^2 + I_{xy}^2}$$

$$= \frac{55.55 + 13.89}{2} \pm \sqrt{\left(\frac{55.55 - 13.89}{2}\right)^2 + (-20.73)^2}$$

$$I_{max} = 64.1 \text{ in}^4 \quad \text{Ans}$$

$$I_{min} = 5.33 \text{ in}^4 \quad \text{Ans}$$

10-82. Determine the principal moments of inertia for the angle's cross-sectional area with respect to a set of principal axes that have their origin located at the centroid C . Use the equation developed in Section 10-7. For the calculation, assume all corners to be square.

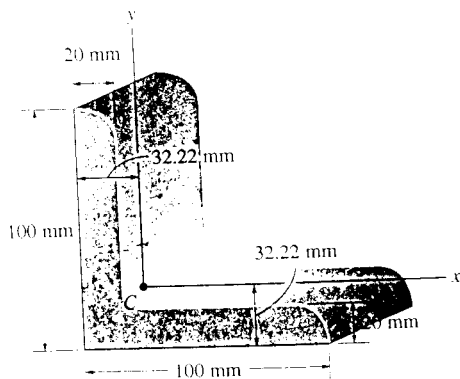

$$I_x = \left[\frac{1}{12}(20)(100)^3 + 100(20)(50 - 32.22)^2 \right] + \left[\frac{1}{12}(80)(20)^3 + 80(20)(32.22 - 10)^2 \right]$$

$$= 3.142(10^6) \text{ mm}^4$$

$$I_y = \left[\frac{1}{12}(100)(20)^3 + 100(20)(32.22 - 10)^2 \right] + \left[\frac{1}{12}(20)(80)^3 + 80(20)(60 - 32.22)^2 \right]$$

$$= 3.142(10^6) \text{ mm}^4$$

$$I_{xy} = \Sigma \bar{x}\bar{y}A$$

$$= -(32.22 - 10)(50 - 32.22)(100)(20) - (60 - 32.22)(32.22 - 10)(80)(20)$$

$$= -1.778(10^6) \text{ mm}^4$$

$$I_{max/min} = \frac{I_x + I_y}{2} \pm \sqrt{\left(\frac{I_x - I_y}{2}\right)^2 + I_{xy}^2}$$

$$= 3.142(10^6) \pm \sqrt{0 + \{(-1.778)(10^6)\}^2}$$

$$I_{max} = 4.92(10^6) \text{ mm}^4 \quad \text{Ans}$$

$$I_{min} = 1.36(10^6) \text{ mm}^4 \quad \text{Ans}$$

10-83. The area of the cross section of an airplane wing has the following properties about the x and y axes passing through the centroid C : $\bar{I}_x = 450 \text{ in}^4$, $\bar{I}_y = 1730 \text{ in}^4$, $\bar{I}_{xy} = 138 \text{ in}^4$. Determine the orientation of the principal axes and the principal moments of inertia.

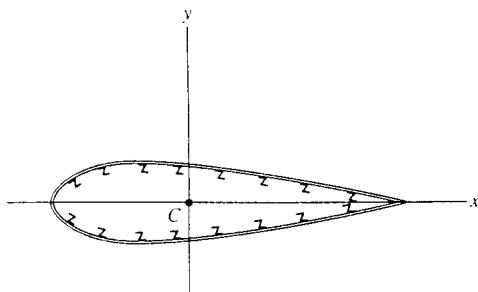

$$\tan 2\theta = \frac{-2I_{xy}}{I_x - I_y} = \frac{-2(138)}{450 - 1730}$$

$$\theta = 6.08^\circ \quad \text{Ans}$$

$$I_{max/min} = \frac{I_x + I_y}{2} \pm \sqrt{\left(\frac{I_x - I_y}{2}\right)^2 + I_{xy}^2}$$

$$= \frac{450 + 1730}{2} \pm \sqrt{\left(\frac{450 - 1730}{2}\right)^2 + 138^2}$$

$$I_{max} = 1.74(10^3) \text{ in}^4 \quad \text{Ans}$$

$$I_{min} = 435 \text{ in}^4 \quad \text{Ans}$$

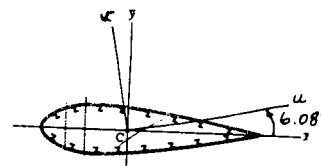

***10-84.** Determine the moments of inertia I_u and I_v of the shaded area.

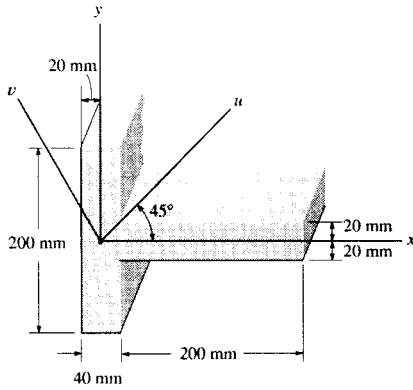

Moment and Product of Inertia about x and y Axes: Since the shaded area is symmetrical about the x axis, $I_{xy} = 0$.

$$I_x = \frac{1}{12}(200)(40^3) + \frac{1}{12}(40)(200^3) = 27.73(10^6) \text{ mm}^4$$

$$I_y = \frac{1}{12}(40)(200^3) + 40(200)(120^2) + \frac{1}{12}(200)(40^3)$$

$$= 142.93(10^6) \text{ mm}^4$$

Moment of Inertia about the Inclined u and v Axes: Applying Eq. 10-9 with $\theta = 45^\circ$, we have

$$I_u = \frac{I_x + I_y}{2} + \frac{I_x - I_y}{2} \cos 2\theta - I_{xy} \sin 2\theta$$

$$= \left(\frac{27.73 + 142.93}{2} + \frac{27.73 - 142.93}{2} \cos 90^\circ - 0(\sin 90^\circ) \right) (10^6)$$

$$= 85.3(10^6) \text{ mm}^4 \quad \text{Ans}$$

$$I_v = \frac{I_x + I_y}{2} - \frac{I_x - I_y}{2} \cos 2\theta + I_{xy} \sin 2\theta$$

$$= \left(\frac{27.73 + 142.93}{2} - \frac{27.73 - 142.93}{2} \cos 90^\circ - 0(\sin 90^\circ) \right) (10^6)$$

$$= 85.3(10^6) \text{ mm}^4 \quad \text{Ans}$$

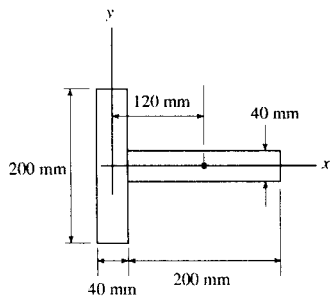

10-85. Solve Prob. 10-78 using Mohr's circle.

See solution to Prob. 10-78.

$$I_x = 216 \text{ in}^4$$

$$I_y = 54 \text{ in}^4$$

$$I_{xy} = 81 \text{ in}^4$$

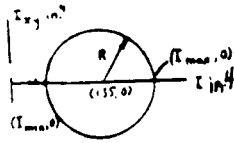

$$\text{Center of circle: } \frac{I_x + I_y}{2} = 135$$

$$R = \sqrt{(216 - 135)^2 + (81)^2} = 114.55$$

$$I_{max} = 135 + 114.55 = 250 \text{ in}^4 \quad \text{Ans}$$

$$I_{min} = 135 - 114.55 = 20.4 \text{ in}^4 \quad \text{Ans}$$

10-86. Solve Prob. 10-81 using Mohr's circle.

See prob. 10-81.

$$I_x = 55.55 \text{ in}^4$$

$$I_y = 13.89 \text{ in}^4$$

$$I_{xy} = -20.73 \text{ in}^4$$

Center of circle;

$$\frac{I_x + I_y}{2} = 34.72 \text{ in}^4$$

$$R = \sqrt{(55.55 - 34.72)^2 + (-20.73)^2} = 29.39 \text{ in}^4$$

$$I_{max} = 34.72 + 29.39 = 64.1 \text{ in}^4 \quad \text{Ans}$$

$$I_{min} = 34.72 - 29.39 = 5.33 \text{ in}^4 \quad \text{Ans}$$

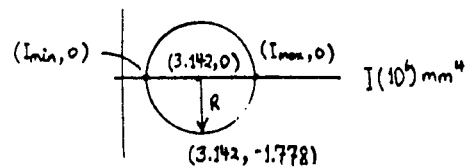

10-87. Solve Prob. 10-82 using Mohr's circle.

See Prob. 10-82.

$$I_x = 3.142(10^6) \text{ mm}^4$$

$$I_y = 3.142(10^6) \text{ mm}^4$$

$$I_{xy} = -1.778(10^6) \text{ mm}^4$$

Center of circle:

$$\frac{I_x + I_y}{2} = 3.142(10^6) \text{ mm}^4$$

$$R = \sqrt{(3.142 - 3.142)^2 + (-1.778)^2(10^6)} = 1.778(10^6) \text{ mm}^4$$

$$I_{max} = 3.142(10^6) + 1.778(10^6) = 4.92(10^6) \text{ mm}^4 \quad \text{Ans}$$

$$I_{min} = 3.142(10^6) - 1.778(10^6) = 1.36(10^6) \text{ mm}^4 \quad \text{Ans}$$

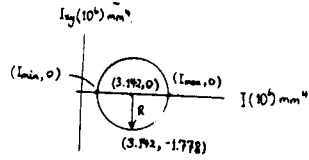

*10-88. Solve Prob. 10-80 using Mohr's circle.

See solution to Prob. 10-80.

$$I_x = 236.95 \text{ in}^4$$

$$I_y = 114.65 \text{ in}^4$$

$$I_{xy} = 118.87 \text{ in}^4$$

$$\frac{I_x + I_y}{2} = \frac{236.95 + 114.65}{2} = 175.8 \text{ in}^4$$

$$R = \sqrt{(236.95 - 175.8)^2 + (118.87)^2} = 133.68 \text{ in}^4$$

$$I_{max} = (175.8 + 133.68) = 309 \text{ in}^4 \quad \text{Ans}$$

$$I_{min} = (175.8 - 133.68) = 42.1 \text{ in}^4 \quad \text{Ans}$$

$$2\theta_{p_1} = \tan^{-1}\left(\frac{118.87}{(236.95 - 175.8)}\right) = 62.78^\circ$$

$$\theta_{p_1} = -31.4^\circ \quad \text{Ans}$$

$$\theta_{p_2} = 90^\circ - 31.4^\circ = 58.6^\circ \quad \text{Ans}$$

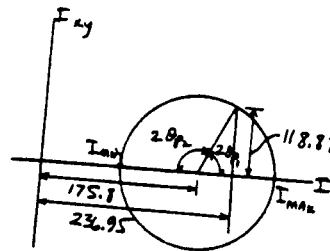

10-89. Solve Prob. 10-83 using Mohr's circle.

From Prob. 10-83,

$$\bar{I}_x = 450 \text{ in}^4, \quad \bar{I}_y = 1730 \text{ in}^4, \quad \bar{I}_{xy} = 138 \text{ in}^4$$

Center of circle

$$\frac{\bar{I}_x + \bar{I}_y}{2} = \frac{450 + 1730}{2} = 1090 \text{ in}^4$$

$$\text{Radius } R = \sqrt{(-640)^2 + (138)^2}$$

$$R = 654.71 \sqrt{(-640)^2 + (138)^2}$$

$$I_{max} = 1090 + 654.71 = 1744.7 = 1.74(10^3) \text{ in}^4 \quad \text{Ans}$$

$$I_{min} = 1090 - 654.71 = 435 \text{ in}^4 \quad \text{Ans}$$

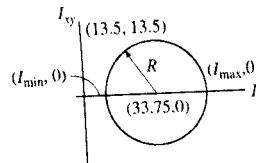

***10-90.** Determine the moment of inertia I_y for the slender rod. The rod's density ρ and cross-sectional area A are constant. Express the result in terms of the rod's total mass m .

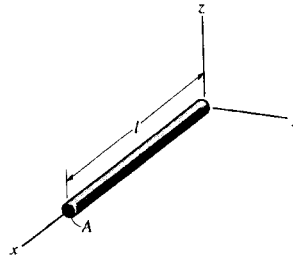

$$I_y = \int_M x^2 dm$$

$$= \int_0^l x^2 (\rho A dx)$$

$$= \frac{1}{3} \rho A l^3$$

$$m = \rho A l$$

Thus,

$$I_y = \frac{1}{3} m l^2 \quad \text{Ans}$$

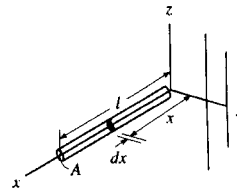

10-91. Determine the moment of inertia of the thin ring about the z axis. The ring has a mass m .

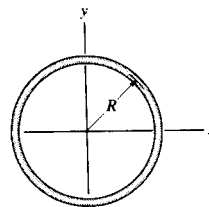

$$I_z = \int_0^{2\pi} \rho A (R d\theta) R^2 = 2\pi \rho A R^3$$

$$m = \int_0^{2\pi} \rho A R d\theta = 2\pi \rho A R$$

Thus,

$$I_z = m R^2 \quad \text{Ans}$$

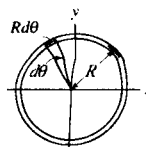

***10-92.** Determine the moment of inertia I_x of the right circular cone and express the result in terms of the total mass m of the cone. The cone has a constant density ρ .

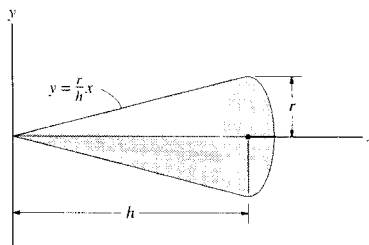

Differential Disk Element: The mass of the differential disk element is $dm = \rho dV = \rho \pi y^2 dx = \rho \pi \left(\frac{r^2}{h^2} x^2 \right) dx$. The mass moment of inertia of this element is $dI_x = \frac{1}{2} dmy^2 = \frac{1}{2} \left[\rho \pi \left(\frac{r^2}{h^2} x^2 \right) dx \right] \left(\frac{r^2}{h^2} x^2 \right) = \frac{\rho \pi r^4}{2h^4} x^4 dx$.

Total Mass: Performing the integration, we have

$$m = \int_m dm = \int_0^h \rho \pi \left(\frac{r^2}{h^2} x^2 \right) dx = \frac{\rho \pi r^2}{h^2} \left(\frac{x^3}{3} \right) \Big|_0^h = \frac{1}{3} \rho \pi r^2 h$$

Mass Moment of Inertia: Performing the integration, we have

$$I_x = \int dI_x = \int_0^h \frac{\rho \pi r^4}{2h^4} x^4 dx = \frac{\rho \pi r^4}{2h^4} \left(\frac{x^5}{5} \right) \Big|_0^h = \frac{1}{10} \rho \pi r^4 h$$

The mass moment of inertia expressed in terms of the total mass is

$$I_x = \frac{3}{10} \left(\frac{1}{3} \rho \pi r^2 h \right) r^2 = \frac{3}{10} mr^2 \quad \text{Ans}$$

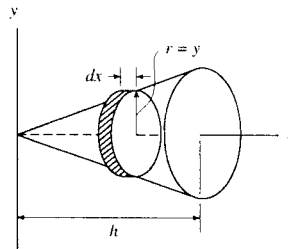

10-93. Determine the moment of inertia I_x of the sphere and express the result in terms of the total mass m of the sphere. The sphere has a constant density ρ .

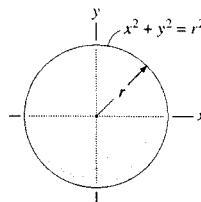

$$dI_x = \frac{y^2 dm}{2}$$

$$dm = \rho dV = \rho (\pi y^2 dx) = \rho \pi (r^2 - x^2) dx$$

$$dI_x = \frac{1}{2} \rho \pi (r^2 - x^2)^2 dx$$

$$I_x = \int_{-r}^r \frac{1}{2} \rho \pi (r^2 - x^2)^2 dx$$

$$= \frac{8}{15} \pi \rho r^5$$

$$m = \int_{-r}^r \rho \pi (r^2 - x^2) dx$$

$$= \frac{4}{3} \rho \pi r^3$$

Thus,

$$I_x = \frac{2}{5} mr^2 \quad \text{Ans}$$

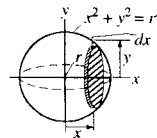

10-94. Determine the radius of gyration k_x of the paraboloid. The density of the material is $\rho = 5 \text{ Mg/m}^3$.

Differential Disk Element: The mass of the differential disk element is $dm = \rho dV = \rho \pi y^2 dx = \rho \pi (50x) dx$. The mass moment of inertia of this element is $dI_x = \frac{1}{2} dm y^2 = \frac{1}{2} [\rho \pi (50x) dx] (50x) = \frac{\rho \pi}{2} (2500x^2) dx$.

Total Mass: Performing the integration, we have

$$m = \int_m dm = \int_0^{200 \text{ mm}} \rho \pi (50x) dx = \rho \pi (25x^2) \Big|_0^{200 \text{ mm}} = 1(10^6) \rho \pi$$

Mass Moment of Inertia: Performing the integration, we have

$$\begin{aligned} I_x &= \int dI_x = \int_0^{200 \text{ mm}} \frac{\rho \pi}{2} (2500x^2) dx \\ &= \frac{\rho \pi}{2} \left(\frac{2500x^3}{3} \right) \Big|_0^{200 \text{ mm}} \\ &= 3.333(10^9) \rho \pi \end{aligned}$$

The radius of gyration is

$$k_x = \sqrt{\frac{I_x}{m}} = \sqrt{\frac{3.333(10^9) \rho \pi}{1(10^6) \rho \pi}} = 57.7 \text{ mm} \quad \text{Ans}$$

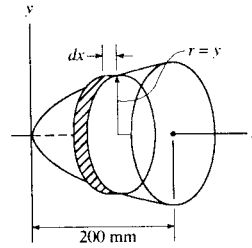
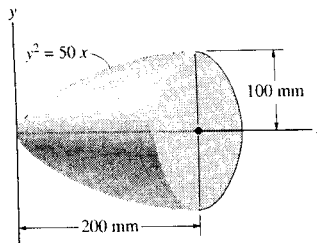

10-95. Determine the moment of inertia of the semiellipsoid with respect to the x axis and express the result in terms of the mass m of the semiellipsoid. The material has a constant density ρ .

Differential Disk Element: Here, $y^2 = b^2 \left(1 - \frac{x^2}{a^2} \right)$. The mass of the differential disk element is $dm = \rho dV = \rho \pi y^2 dx = \rho \pi b^2 \left(1 - \frac{x^2}{a^2} \right) dx$. The mass moment of inertia of this element is $dI_x = \frac{1}{2} dm y^2 = \frac{1}{2} \left[\rho \pi b^2 \left(1 - \frac{x^2}{a^2} \right) dx \right] \left[b^2 \left(1 - \frac{x^2}{a^2} \right) \right] = \frac{\rho \pi b^4}{2} \left(\frac{x^4}{a^4} - \frac{2x^2}{a^2} + 1 \right) dx$.

Total Mass: Performing the integration, we have

$$\begin{aligned} m &= \int_m dm = \int_0^a \rho \pi b^2 \left(1 - \frac{x^2}{a^2} \right) dx = \rho \pi b^2 \left(x - \frac{x^3}{3a^2} \right) \Big|_0^a \\ &= \frac{2}{3} \rho \pi a b^2 \end{aligned}$$

Mass Moment of Inertia: Performing the integration, we have

$$\begin{aligned} I_x &= \int dI_x = \int_0^a \frac{\rho \pi b^4}{2} \left(\frac{x^4}{a^4} - \frac{2x^2}{a^2} + 1 \right) dx \\ &= \frac{\rho \pi b^4}{2} \left(\frac{x^5}{5a^4} - \frac{2x^3}{3a^2} + x \right) \Big|_0^a \\ &= \frac{4}{15} \rho \pi a b^4 \end{aligned}$$

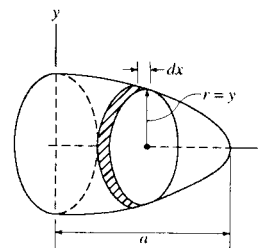
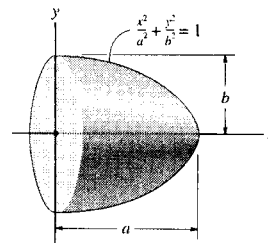

The mass moment of inertia expressed in terms of the total mass is

$$I_x = \frac{2}{5} \left(\frac{2}{3} \rho \pi a b^2 \right) b^2 = \frac{2}{5} m b^2 \quad \text{Ans}$$

***10-96.** Determine the radius of gyration k_x . The specific weight of the material is $\gamma = 380 \text{ lb/ft}^3$.

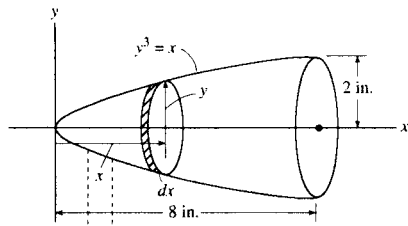

$$dm = \rho dV = \rho \pi y^2 dx$$

$$dI_x = \frac{1}{2}(dm)y^2 = \frac{1}{2}\pi \rho y^4 dx$$

$$I_x = \int_0^8 \frac{1}{2}\pi \rho x^{4/3} dx = 86.17\rho$$

$$m = \int_0^8 \pi \rho x^{2/3} dx = 60.32\rho$$

$$k_x = \sqrt{\frac{I_x}{m}} = \sqrt{\frac{86.17\rho}{60.32\rho}} = 1.20 \text{ in. Ans}$$

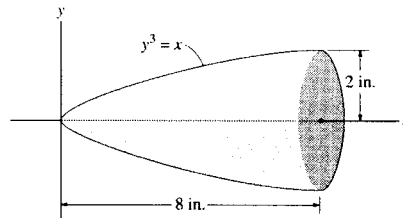

10-97. Determine the moment of inertia of the ellipsoid with respect to the x axis and express the result in terms of the mass m of the ellipsoid. The material has a constant density ρ .

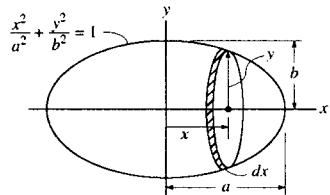

$$dI_x = \frac{y^2 dm}{2}$$

$$m = \int_V \rho dV = \int_{-a}^a \rho \pi b^2 \left(1 - \frac{x^2}{a^2}\right) dx = \frac{4}{3}\pi \rho ab^2$$

$$I_x = \int_{-a}^a \frac{1}{2}\rho \pi b^4 \left(1 - \frac{x^2}{a^2}\right)^2 dx = \frac{8}{15}\pi \rho ab^4$$

Thus,

$$I_x = \frac{2}{5}mb^2 \text{ Ans}$$

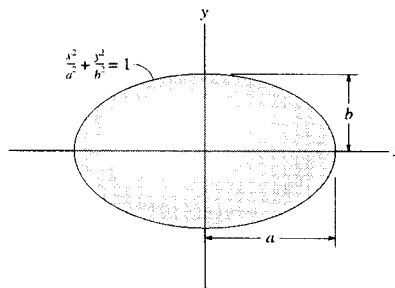

10-98. Determine the moment of inertia of the homogenous triangular prism with respect to the y axis. Express the result in terms of the mass m of the prism. *Hint:* For integration, use thin plate elements parallel to the x - y plane having a thickness of dz .

Differential Thin Plate Element: Here, $x = a\left(1 - \frac{z}{h}\right)$. The mass of the differential thin plate element is $dm = \rho dV = \rho bxdz = \rho ab\left(1 - \frac{z}{h}\right)dz$. The mass moment of inertia of this element about y axis is

$$\begin{aligned} dI_y &= dI_G + dmr^2 \\ &= \frac{1}{12}dmx^2 + dm\left(\frac{x^2}{4} + z^2\right) \\ &= \frac{1}{3}x^2 dm + z^2 dm \\ &= \left[\frac{a^2}{3}\left(1 - \frac{z}{h}\right)^2 + z^2\right] \left[\rho ab\left(1 - \frac{z}{h}\right) dz\right] \\ &= \frac{\rho ab}{3} \left(a^2 + \frac{3a^2}{h^2}z^2 - \frac{3a^2}{h}z - \frac{a^2}{h^3}z^3 + 3z^2 - \frac{3z^3}{h}\right) dz \end{aligned}$$

Total Mass: Performing the integration, we have

$$m = \int_m dm = \int_0^h \rho ab \left(1 - \frac{z}{h}\right) dz = \rho \pi b \left(z - \frac{z^2}{2h}\right) \Big|_0^h = \frac{1}{2} \rho abh$$

Mass Moment of Inertia: Performing the integration, we have

$$\begin{aligned} I_y &= \int dI_y = \int_0^h \frac{\rho ab}{3} \left(a^2 + \frac{3a^2}{h^2}z^2 - \frac{3a^2}{h}z - \frac{a^2}{h^3}z^3 + 3z^2 - \frac{3z^3}{h}\right) dz \quad \text{The mass moment of inertia expressed in terms of the total mass is} \\ &= \frac{\rho ab}{3} \left(a^2 z + \frac{a^2}{h^2}z^3 - \frac{3a^2}{2h}z^2 - \frac{a^2}{4h^3}z^4 + z^3 - \frac{3z^4}{4h}\right) \Big|_0^h \\ &= \frac{\rho abh}{12} (a^2 + h^2) \end{aligned}$$

$$I_y = \frac{1}{6} \left(\frac{\rho abh}{2}\right) (a^2 + h^2) = \frac{m}{6} (a^2 + h^2) \quad \text{Ans}$$

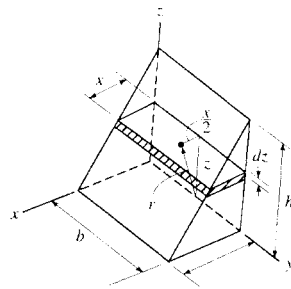
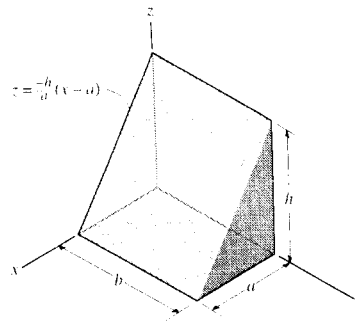

10-99. The concrete shape is formed by rotating the shaded area about the y axis. Determine the moment of inertia I_y . The specific weight of concrete is $\gamma = 150 \text{ lb/ft}^3$.

$$\begin{aligned} dI_y &= \frac{1}{2}(dm)(10)^2 - \frac{1}{2}(dm)x^2 \\ &= \frac{1}{2}[\pi\rho(10)^2 dy](10)^2 - \frac{1}{2}\pi\rho x^2 dyx^2 \\ I_y &= \frac{1}{2}\pi\rho \left[\int_0^8 (10)^4 dy - \int_0^8 \left(\frac{9}{2}\right)^2 y^2 dy \right] \\ &= \frac{1}{2}\pi(150) \left[(10)^4(8) - \left(\frac{9}{2}\right)^2 \left(\frac{1}{3}\right)(8)^3 \right] \\ &= 324.1 \text{ slug} \cdot \text{in}^2 \end{aligned}$$

$$I_y = 2.25 \text{ slug} \cdot \text{ft}^2$$

Ans

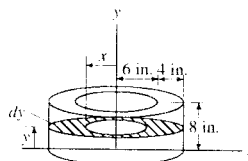
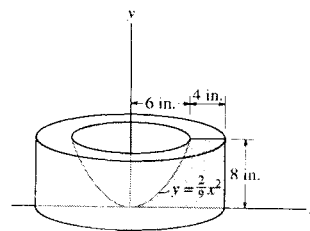

***10-100.** Determine the moment of inertia of the wire triangle about an axis perpendicular to the page and passing through point O . Also, locate the mass center G and determine the moment of inertia about an axis perpendicular to the page and passing through point G . The wire has a mass of 0.3 kg/m . Neglect the size of the ring at O .

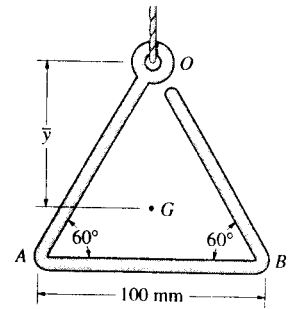

Mass Moment of Inertia About an Axis Through Point O : The mass for each wire segment is $m_i = 0.3(0.1) = 0.03 \text{ kg}$. The mass moment of inertia of each segment about an axis passing through the center of mass can be determined using $(I_G)_i = \frac{1}{12} m_i l_i^2$. Applying Eq. 10-16, we have

$$\begin{aligned}
 I_O &= \Sigma(I_G)_i + m_i d_i^2 \\
 &= 2 \left[\frac{1}{12} (0.03) (0.1)^2 + 0.03 (0.05)^2 \right] \\
 &\quad + \frac{1}{12} (0.03) (0.1)^2 + 0.03 (0.1 \sin 60^\circ)^2 \\
 &= 0.450 (10^{-3}) \text{ kg} \cdot \text{m}^2 \quad \text{Ans}
 \end{aligned}$$

Location of Centroid:

$$\begin{aligned}
 \bar{y} &= \frac{\Sigma \bar{y} m}{\Sigma m} = \frac{2[0.05 \sin 60^\circ (0.03)] + 0.1 \sin 60^\circ (0.03)}{3(0.03)} \\
 &= 0.05774 \text{ m} = 57.7 \text{ mm} \quad \text{Ans}
 \end{aligned}$$

Mass Moment of Inertia About an Axis Through Point G : Using the result $I_O = 0.450 (10^{-3}) \text{ kg} \cdot \text{m}^2$ and $d = \bar{y} = 0.05774 \text{ m}$ and applying Eq. 10-16, we have

$$\begin{aligned}
 I_O &= I_G + m d^2 \\
 0.450 (10^{-3}) &= I_G + 3(0.03) (0.05774)^2 \\
 I_G &= 0.150 (10^{-3}) \text{ kg} \cdot \text{m}^2 \quad \text{Ans}
 \end{aligned}$$

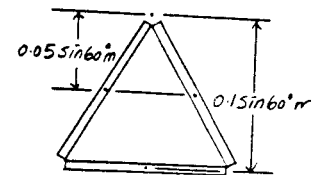
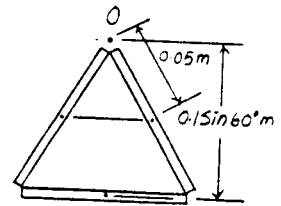

10-101. Determine the moment of inertia I_z of the frustum of the cone which has a conical depression. The material has a density of 200 kg/m^3 .

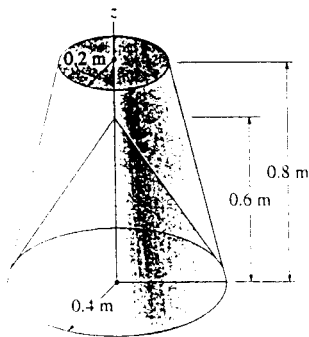

$$\begin{aligned}
 I_z &= \frac{3}{10} \left[\frac{1}{3} \pi (0.4)^2 (1.6) (200) \right] (0.4)^2 \\
 &\quad - \frac{3}{10} \left[\frac{1}{3} \pi (0.2)^2 (0.8) (200) \right] (0.2)^2 \\
 &\quad - \frac{3}{10} \left[\frac{1}{3} \pi (0.4)^2 (0.6) (200) \right] (0.4)^2
 \end{aligned}$$

$$I_z = 1.53 \text{ kg} \cdot \text{m}^2 \quad \text{Ans}$$

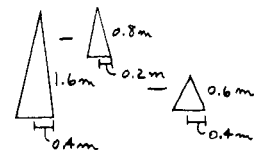

10-102. Determine the moment of inertia of the wheel about the x axis that passes through the center of mass G . The material has a specific weight of $\gamma = 90 \text{ lb/ft}^3$.

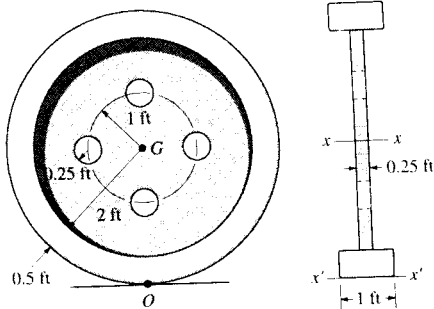

Mass Moment of Inertia About an Axis Through Point G : The mass moment of inertia of each disk about an axis passing through the center of mass can be determined using $(I_G)_i = \frac{1}{2}mr^2$. Applying Eq. 10-16, we have

$$\begin{aligned}
 I_G &= \Sigma(I_G)_i + m_i d_i^2 \\
 &= \frac{1}{2} \left[\frac{\pi(2.5^2)(1)(90)}{32.2} \right] (2.5^2) - \frac{1}{2} \left[\frac{\pi(2^2)(0.75)(90)}{32.2} \right] (2^2) \\
 &\quad - 4 \left\{ \frac{1}{2} \left[\frac{\pi(0.25^2)(0.25)(90)}{32.2} \right] (0.25^2) + \left[\frac{\pi(0.25^2)(0.25)(90)}{32.2} \right] (1^2) \right\} \\
 &= 118 \text{ slug} \cdot \text{ft}^2 \qquad \text{Ans}
 \end{aligned}$$

10-103. Determine the moment of inertia of the wheel about the x' axis that passes through point O . The material has a specific weight of $\gamma = 90 \text{ lb/ft}^3$.

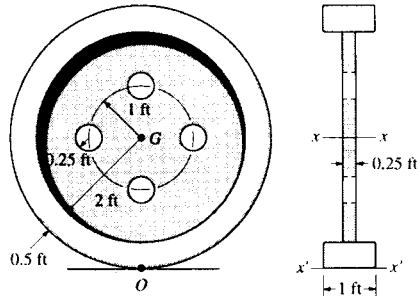

Mass Moment of Inertia About an Axis Through Point G : The mass moment of inertia of each disk about an axis passing through the center of mass can be determined using $(I_G)_i = \frac{1}{2} m r^2$. Applying Eq. 10-16, we have

$$\begin{aligned}
 I_G &= \sum (I_G)_i + m_i d_i^2 \\
 &= \frac{1}{2} \left[\frac{\pi (2.5^2) (1) (90)}{32.2} \right] (2.5^2) - \frac{1}{2} \left[\frac{\pi (2^2) (0.75) (90)}{32.2} \right] (2^2) \\
 &\quad - 4 \left\{ \frac{1}{2} \left[\frac{\pi (0.25^2) (0.25) (90)}{32.2} \right] (0.25^2) \right. \\
 &\quad \left. + \left[\frac{\pi (0.25^2) (0.25) (90)}{32.2} \right] (1^2) \right\} \\
 &= 118.25 \text{ slug} \cdot \text{ft}^2
 \end{aligned}$$

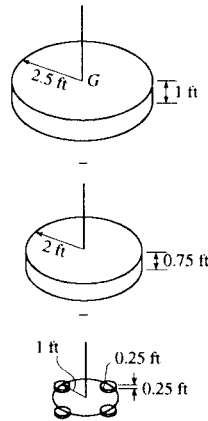

Mass Moment of Inertia About an Axis Through Point O : The mass of the wheel is

$$\begin{aligned}
 m &= \frac{\pi (2.5^2) (1) (90)}{32.2} - \frac{\pi (2^2) (0.75) (90)}{32.2} - 4 \left[\frac{\pi (0.25^2) (0.25) (90)}{32.2} \right] \\
 &= 27.989 \text{ slug}
 \end{aligned}$$

Using the result $I_G = 118.25 \text{ slug} \cdot \text{ft}^2$ and applying Eq. 10-16, we have

$$\begin{aligned}
 I_O &= I_G + m d^2 \\
 &= 118.25 + 27.989 (2.5^2) \\
 &= 293 \text{ slug} \cdot \text{ft}^2 \quad \text{Ans}
 \end{aligned}$$

***10-104.** The pendulum consists of a disk having a mass of 6 kg and slender rods AB and DC which have a mass of 2 kg/m. Determine the length L of DC so that the center of the mass is at the bearing O . What is the moment of inertia of the assembly about an axis perpendicular to the page and passing through point O ?

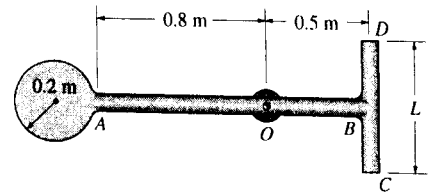

Location of Centroid : This problem requires $\bar{x} = 0.5$ m.

$$\bar{x} = \frac{\sum \bar{x}m}{\sum m}$$

$$0.5 = \frac{1.5(6) + 0.65[1.3(2)] + 0[L(2)]}{6 + 1.3(2) + L(2)}$$

$$L = 6.39 \text{ m} \quad \text{Ans}$$

Mass Moment of Inertia About an Axis Through Point O : The mass moment of inertia of each rod segment and disk about an axis passing through the center of mass can be determine using $(I_G)_i = \frac{1}{12}ml^2$ and $(I_G)_i = \frac{1}{2}mr^2$. Applying Eq. 10-16, we have

$$I_o = \sum (I_G)_i + m_i d_i^2$$

$$= \frac{1}{12}[1.3(2)](1.3^2) + [1.3(2)](0.15^2)$$

$$+ \frac{1}{12}[6.39(2)](6.39^2) + [6.39(2)](0.5^2)$$

$$+ \frac{1}{2}(6)(0.2^2) + 6(1^2)$$

$$= 53.2 \text{ kg} \cdot \text{m}^2 \quad \text{Ans}$$

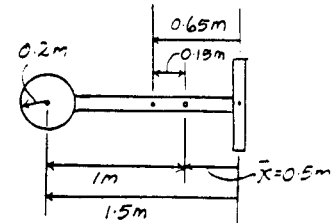

10-105. The slender rods have a weight of 3 lb/ft. Determine the moment of inertia of the assembly about an axis perpendicular to the page and passing through point A .

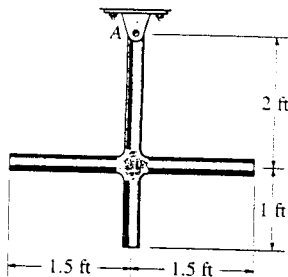

$$I = \frac{1}{3}\left(3\left(\frac{3}{32.2}\right)\right)(3)^2 + \frac{1}{12}\left(3\left(\frac{3}{32.2}\right)\right)(3)^2 + \left(3\left(\frac{3}{32.2}\right)\right)(2)^2$$

$$= 2.17 \text{ slug} \cdot \text{ft}^2 \quad \text{Ans}$$

10-106. Determine the moment of inertia I_z of the frustrum of the cone which has a conical depression. The material has a density of 200 kg/m^3 .

Mass Moment of Inertia About z Axis : From similar triangles,

$\frac{z}{0.2} = \frac{z+1}{0.8}$, $z = 0.333 \text{ m}$. The mass moment of inertia of each cone about z axis can be determine using $I_z = \frac{3}{10}mr^2$.

$$I_z = \Sigma(I_z)_i = \frac{3}{10} \left[\frac{\pi}{3} (0.8^2) (1.333) (200) \right] (0.8^2) - \frac{3}{10} \left[\frac{\pi}{3} (0.2^2) (0.333) (200) \right] (0.2^2) - \frac{3}{10} \left[\frac{\pi}{3} (0.2^2) (0.6) (200) \right] (0.2^2)$$

$$= 34.2 \text{ kg} \cdot \text{m}^2 \quad \text{Ans}$$

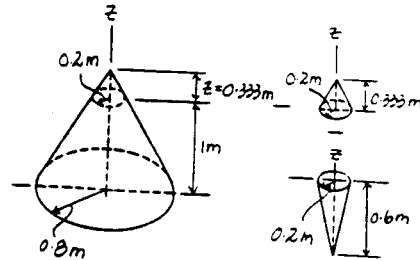
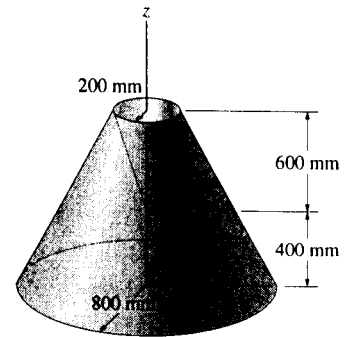

10-107. The slender rods have a weight of 3 lb/ft . Determine the moment of inertia of the assembly about an axis perpendicular to the page and passing through point A .

$$I_A = \frac{1}{3} \left[\frac{3(2)}{32.2} \right] (2)^2 + \frac{1}{12} \left[\frac{3(3)}{32.2} \right] (3)^2 + \left[\frac{3(3)}{32.2} \right] (2)^2 = 1.58 \text{ slug} \cdot \text{ft}^2 \quad \text{Ans}$$

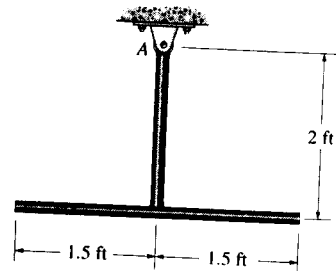

*10-108. The pendulum consists of a plate having a weight of 12 lb and a slender rod having a weight of 4 lb . Determine the radius of gyration of the pendulum about an axis perpendicular to the page and passing through point O .

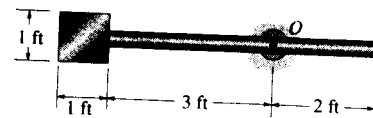

$$I_O = \Sigma I_O + md^2$$

$$= \frac{1}{12} \left(\frac{4}{32.2} \right) (5)^2 + \left(\frac{4}{32.2} \right) (0.5)^2 + \frac{1}{12} \left(\frac{12}{32.2} \right) (1^2 + 1^2) + \left(\frac{12}{32.2} \right) (3.5)^2$$

$$= 4.917 \text{ slug} \cdot \text{ft}^2$$

$$m = \left(\frac{4}{32.2} \right) + \left(\frac{12}{32.2} \right) = 0.4969 \text{ slug}$$

$$k_O = \sqrt{\frac{I_O}{m}} = \sqrt{\frac{4.917}{0.4969}} = 3.15 \text{ ft} \quad \text{Ans}$$

10-109. Determine the moment of inertia of the overhung crank about the x axis. The material is steel having a density of $\rho = 7.85 \text{ Mg/m}^3$.

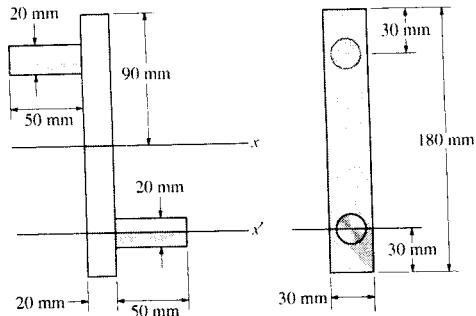

Let m = mass of one handle.

$$\begin{aligned} m &= \rho(\pi r^2 h) \\ &= (7.85 \times 10^3)\pi(0.010)^2(0.050) \\ &= 0.1233 \text{ kg} \end{aligned}$$

Let M = mass of bar.

$$\begin{aligned} M &= \rho(abc) \\ &= (7.85 \times 10^3)(0.03)(0.18)(0.02) \\ &= 0.8478 \text{ kg} \end{aligned}$$

For the assembly,

$$\begin{aligned} I_x &= 2\left(\frac{1}{2}mr^2 + md^2\right) + \frac{1}{12}M(a^2 + b^2) \\ &= 2\left[\frac{1}{2}(0.1233)(0.010)^2 + (0.1233)(0.060)^2\right] \\ &\quad + \frac{1}{12}(0.8478)[(0.030)^2 + (0.18)^2] \\ &= 3.25 \times 10^{-3} \text{ kg} \cdot \text{m}^2 \end{aligned}$$

Ans

10-110. Determine the moment of inertia of the overhung crank about the x' axis. The material is steel having a density of $\rho = 7.85 \text{ Mg/m}^3$.

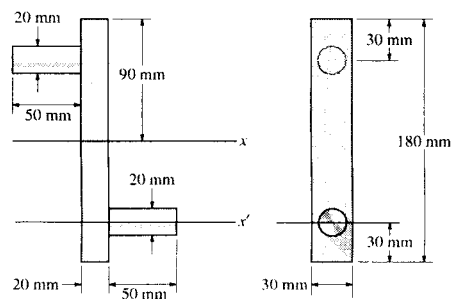

From 10-109, $m = 0.1233 \text{ kg}$, $M = 0.8478 \text{ kg}$, and $I_x = 3.25 \times 10^{-3} \text{ kg} \cdot \text{m}^2$.

$$\begin{aligned} I_{x'} &= I_x + (2m + M)d^2 \\ &= 3.25 \times 10^{-3} + [2(0.1233) + 0.8478](0.060)^2 \\ &= 7.20 \times 10^{-3} \text{ kg} \cdot \text{m}^2 \end{aligned}$$

Ans

10-111. Determine the location of \bar{y} of the center of mass G of the assembly and then calculate the moment of inertia about an axis perpendicular to the page and passing through G . The block has a mass of 3 kg and the mass of the semicylinder is 5 kg.

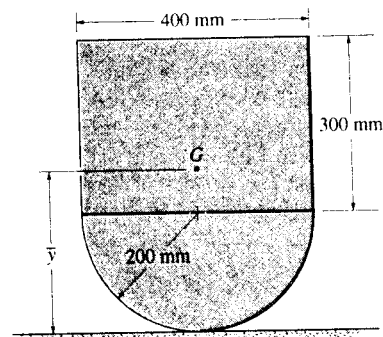

Location of Centroid :

$$\bar{y} = \frac{\Sigma \bar{y}m}{\Sigma m} = \frac{350(3) + 115.12(5)}{3 + 5} = 203.20 \text{ mm} \approx 203 \text{ mm} \quad \text{Ans}$$

Mass Moment of Inertia About an Axis Through Point G : The mass moment of inertia of a rectangular block and a semicylinder about an axis passing through the center of mass perpendicular to the page can be determined using

$$(I_x)_G = \frac{1}{12}m(a^2 + b^2) \quad \text{and} \quad (I_x)_G = \frac{1}{2}mr^2 - m\left(\frac{4r}{3\pi}\right)^2 = 0.3199mr^2$$

respectively. Applying Eq. 10-16, we have

$$\begin{aligned} I_G &= \Sigma (I_x)_{G_i} + m_i d_i^2 \\ &= \left[\frac{1}{12}(3)(0.3^2 + 0.4^2) + 3(0.1468^2) \right] \\ &\quad + \left[0.3199(5)(0.2^2) + 5(0.08808^2) \right] \\ &= 0.230 \text{ kg} \cdot \text{m}^2 \end{aligned}$$

Ans

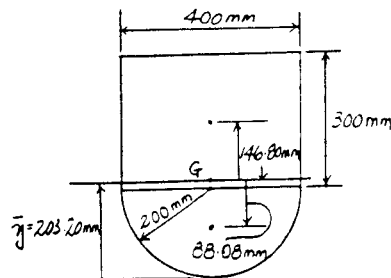
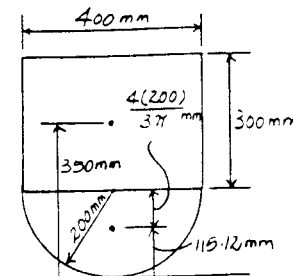

***10-112.** The pendulum consists of two slender rods AB and OC which have a mass of 3 kg/m. The thin plate has a mass of 12 kg/m². Determine the location \bar{y} of the center of mass G of the pendulum, then calculate the moment of inertia of the pendulum about an axis perpendicular to the page and passing through G .

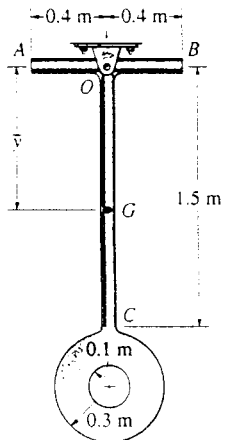

$$\begin{aligned} \bar{y} &= \frac{1.5(3)(0.75) + \pi(0.3)^2(12)(1.8) - \pi(0.1)^2(12)(1.8)}{1.5(3) + \pi(0.3)^2(12) - \pi(0.1)^2(12) + 0.8(3)} \\ &= 0.8878 \text{ m} = 0.888 \text{ m} \quad \text{Ans} \end{aligned}$$

$$\begin{aligned} I_G &= \frac{1}{12}(0.8)(3)(0.8)^2 + 0.8(3)(0.8878)^2 \\ &\quad + \frac{1}{12}(1.5)(3)(1.5)^2 + 1.5(3)(0.75 - 0.8878)^2 \\ &\quad + \frac{1}{2}[\pi(0.3)^2(12)(0.3)^2 + [\pi(0.3)^2(12)](1.8 - 0.8878)^2] \\ &\quad - \frac{1}{2}[\pi(0.1)^2(12)(0.1)^2 - [\pi(0.1)^2(12)](1.8 - 0.8878)^2] \end{aligned}$$

$$I_G = 5.61 \text{ kg} \cdot \text{m}^2 \quad \text{Ans}$$

10-113. Determine the moment of inertia of the beam's cross-sectional area about the x axis which passes through the centroid C .

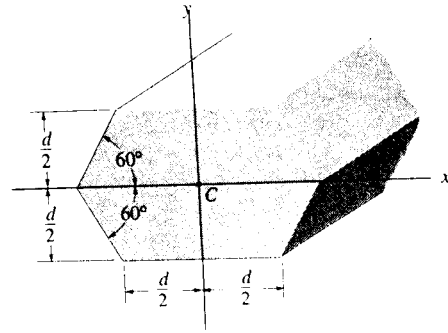

Moment of Inertia : The moment of inertia about the x axis for the composite beam's cross section can be determined using the parallel - axis theorem

$$I_x = \Sigma (\bar{I}_x + A d_y^2)_i$$

$$I_x = \left[\frac{1}{12} (d) (d^3) + 0 \right] + 4 \left[\frac{1}{36} (0.2887d) \left(\frac{d}{2} \right)^3 + \frac{1}{2} (0.2887d) \left(\frac{d}{2} \right) \left(\frac{d}{6} \right)^2 \right]$$

$$= 0.0954d^4 \quad \text{Ans}$$

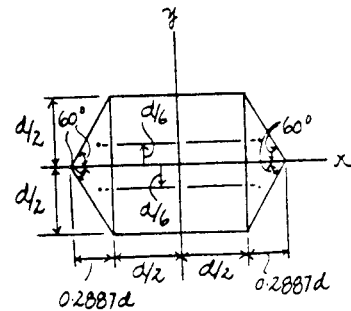

10-114. Determine the moment of inertia of the beam's cross-sectional area about the y axis which passes through the centroid C .

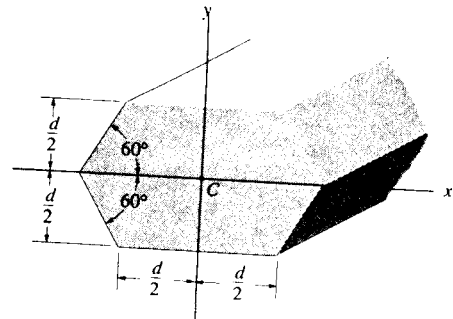

Moment of Inertia : The moment of inertia about y axis for the composite beam's cross section can be determined using the parallel - axis theorem

$$I_y = \Sigma (\bar{I}_y + A d_x^2)_i$$

$$I_y = \left[\frac{1}{12} (d) (d^3) + 0 \right] + 2 \left[\frac{1}{36} (d) (0.2887d)^3 + \frac{1}{2} (d) (0.2887d) (0.5962d)^2 \right]$$

$$= 0.187d^4 \quad \text{Ans}$$

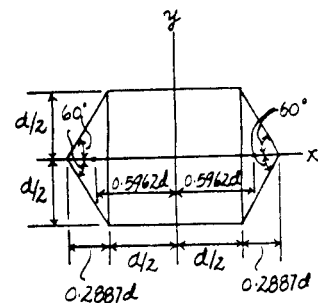

10-115. Determine the moment of inertia I_x of the body and express the result in terms of the total mass m of the body. The density is constant.

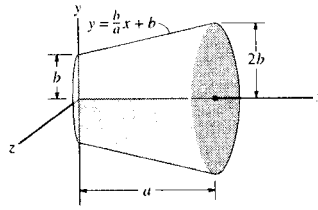

$$dm = \rho dV = \rho \pi y^2 dx = \rho \pi \left(\frac{b^2}{a^2} x^2 + \frac{2b^2}{a} x + b^2 \right) dx$$

$$dI_x = \frac{1}{2} dm y^2 = \frac{1}{2} \rho \pi y^4 dx$$

$$dI_x = \frac{1}{2} \rho \pi \left(\frac{b^4}{a^4} x^4 + \frac{4b^4}{a^3} x^3 + \frac{6b^4}{a^2} x^2 + \frac{4b^4}{a} x + b^4 \right) dx$$

$$I_x = \int dI_x = \frac{1}{2} \rho \pi \int_0^a \left(\frac{b^4}{a^4} x^4 + \frac{4b^4}{a^3} x^3 + \frac{6b^4}{a^2} x^2 + \frac{4b^4}{a} x + b^4 \right) dx$$

$$= \frac{31}{10} \rho \pi a b^4$$

$$m = \int dm = \rho \pi \int_0^a \left(\frac{b^2}{a^2} x^2 + \frac{2b^2}{a} x + b^2 \right) dx = \frac{7}{3} \rho \pi a b^2$$

$$I_x = \frac{93}{70} m b^2$$

Ans

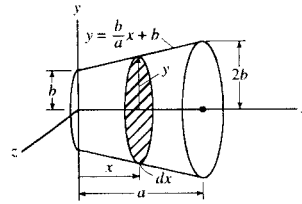

***10-116.** Determine the moments of inertia I_x and I_y of the shaded area.

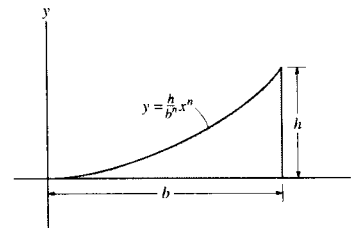

$$I_x = \int dI_x$$

$$= \int_0^b \frac{1}{3} y^3 dx = \int_0^b \frac{h^3}{3 b^{3n}} x^{3n} dx$$

$$= \frac{h^3}{(3n+1)3b^{2n}} b^{3n+1}$$

$$= \frac{1}{3(3n+1)} b h^3 \quad \text{Ans}$$

$$I_y = \int x^2 dA$$

$$= \int_0^b \frac{h}{b^n} x^{n+2} dx$$

$$= \frac{h}{b^n(n+3)} b^{n+3}$$

$$= \frac{1}{n+3} b^3 h \quad \text{Ans}$$

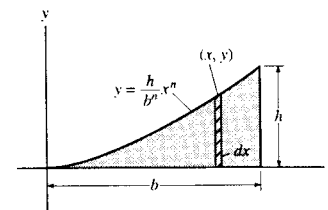

10-117. Determine the moments of inertia I_u and I_v and the product of inertia I_{uv} for the semicircular area.

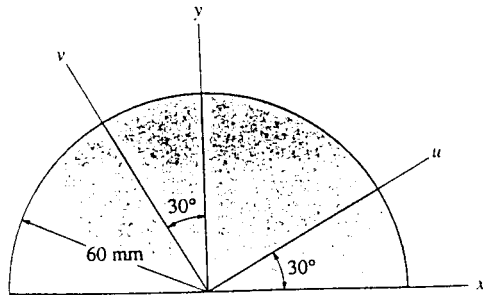

$$I_x = I_y = \frac{1}{8} \pi (60)^4 = 5\,089\,380.1 \text{ mm}^4$$

$$I_{xy} = 0 \quad (\text{Due to symmetry})$$

$$\begin{aligned} I_u &= \frac{I_x + I_y}{2} + \frac{I_x - I_y}{2} \cos 2\theta - I_{xy} \sin 2\theta \\ &= \frac{5\,089\,380.1 + 5\,089\,380.1}{2} + 0 - 0 \end{aligned}$$

$$I_u = 5.09(10^6) \text{ mm}^4 \quad \text{Ans}$$

$$\begin{aligned} I_v &= \frac{I_x + I_y}{2} - \frac{I_x - I_y}{2} \cos 2\theta + I_{xy} \sin 2\theta \\ &= \frac{5\,089\,380.1 + 5\,089\,380.1}{2} - 0 + 0 \end{aligned}$$

$$I_v = 5.09(10^6) \text{ mm}^4 \quad \text{Ans}$$

$$I_{uv} = \frac{I_x - I_y}{2} \sin 2\theta + I_{xy} \cos 2\theta$$

$$= 0 + 0$$

$$I_{uv} = 0 \quad \text{Ans}$$

***10-118.** Determine the moment of inertia of the shaded area about the y axis.

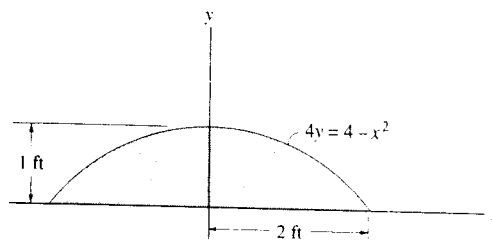

Differential Element : Here, $y = \frac{1}{4}(4 - x^2)$. The area of the differential element parallel to the y axis is $dA = y dx = \frac{1}{4}(4 - x^2) dx$.

Moment of Inertia : Applying Eq. 10-1 and performing the integration, we have

$$\begin{aligned} I_y &= \int_A x^2 dA = \frac{1}{4} \int_{-2\text{ft}}^{2\text{ft}} x^2 (4 - x^2) dx \\ &= \frac{1}{4} \left[\frac{4}{3} x^3 - \frac{1}{5} x^5 \right]_{-2\text{ft}}^{2\text{ft}} \\ &= 2.13 \text{ ft}^4 \end{aligned} \quad \text{Ans}$$

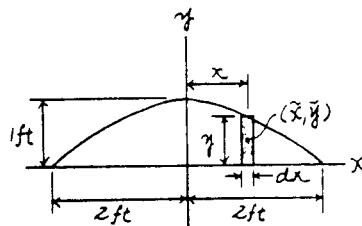

10-119. Determine the moment of inertia of the shaded area about the x axis.

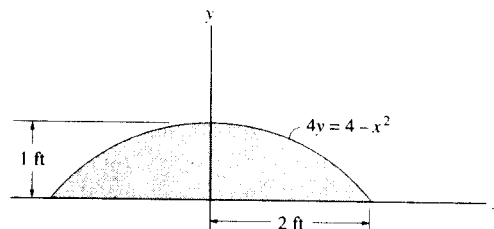

Differential Element : Here, $y = \frac{1}{4}(4 - x^2)$. The area of the differential element parallel to the y axis is $dA = y dx$. The moment of inertia of this differential element about the x axis is

$$\begin{aligned} dI_x &= d\bar{I}_x + dA\bar{y}^2 \\ &= \frac{1}{12}(dx)y^3 + y dx \left(\frac{y}{2}\right)^2 \\ &= \frac{1}{3} \left[\frac{1}{4}(4 - x^2) \right]^3 dx \\ &= \frac{1}{192} (-x^6 + 12x^4 - 48x^2 + 64) dx \end{aligned}$$

Moment of inertia : Performing the integration, we have

$$\begin{aligned} I_x &= \int dI_x = \frac{1}{192} \int_{-2\text{ft}}^{2\text{ft}} (-x^6 + 12x^4 - 48x^2 + 64) dx \\ &= \frac{1}{192} \left(-\frac{1}{7}x^7 + \frac{12}{5}x^5 - 16x^3 + 64x \right) \Big|_{-2\text{ft}}^{2\text{ft}} \\ &= 0.610 \text{ ft}^4 \end{aligned} \quad \text{Ans}$$

***10-120.** Determine the moment of inertia of the area about the x axis. Then, using the parallel-axis theorem, find the moment of inertia about the x' axis that passes through the centroid C of the area. $\bar{y} = 120$ mm.

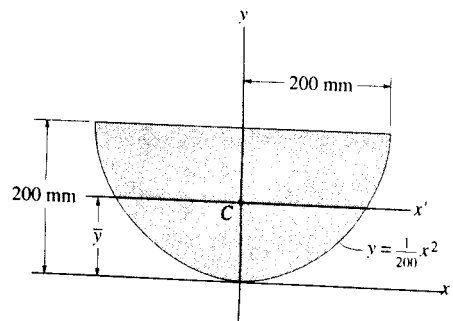

Differential Element: Here, $x = \sqrt{200y}^{\frac{1}{2}}$. The area of the differential element parallel to the x axis is $dA = 2xdy = 2\sqrt{200y}^{\frac{1}{2}}dy$.

Moment of Inertia: Applying Eq. 10-1 and performing the integration, we have

$$\begin{aligned} I_x &= \int_A y^2 dA = \int_0^{200\text{mm}} y^2 (2\sqrt{200y}^{\frac{1}{2}} dy) \\ &= 2\sqrt{200} \left(\frac{2}{7} y^{\frac{7}{2}} \right) \Big|_0^{200\text{mm}} \\ &= 914.29 (10^6) \text{ mm}^4 = 914 (10^6) \text{ mm}^4 \quad \text{Ans} \end{aligned}$$

The moment of inertia about the x' axis can be determined using the parallel-

axis theorem. The area is $A = \int_A dA = \int_0^{200\text{mm}} 2\sqrt{200y}^{\frac{1}{2}} dy = 53.33 (10^3) \text{ mm}^2$

$$\begin{aligned} I_x &= \bar{I}_x + Ad^2 \\ 914.29 (10^6) &= \bar{I}_x + 53.33 (10^3) (120^2) \end{aligned}$$

$$\bar{I}_x = 146 (10^6) \text{ mm}^4 \quad \text{Ans}$$

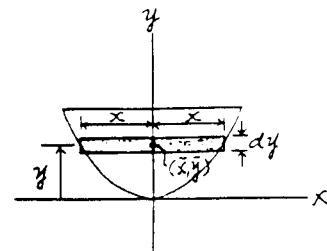

10-121. Determine the moment of inertia of the triangular area about (a) the x axis, and (b) the centroidal x' axis.

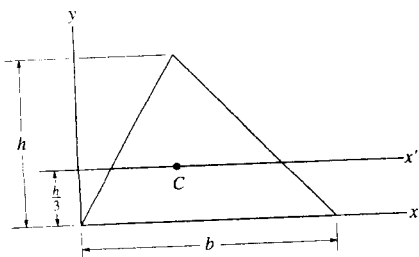

$$\frac{s}{h-y} = \frac{b}{h}$$

$$s = \frac{b}{h}(h-y)$$

$$(a) \quad dA = s dy = \left[\frac{b}{h}(h-y) \right] dy$$

$$I_x = \int y^2 dA$$

$$= \int_0^h y^2 \left[\frac{b}{h}(h-y) \right] dy$$

$$= \frac{bh^3}{12} \quad \text{Ans}$$

$$(b) \quad I_x = \bar{I}_x + Ad^2$$

$$\frac{bh^3}{12} = \bar{I}_x + \frac{1}{2}bh\left(\frac{h}{3}\right)^2$$

$$\bar{I}_x = \frac{bh^3}{36} \quad \text{Ans}$$

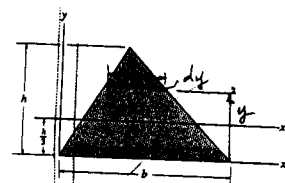

10-122. Determine the product of inertia of the shaded area with respect to the x and y axes.

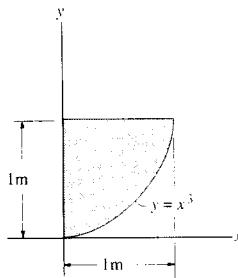

Differential Element: Here, $x = y^{\frac{1}{3}}$. The area of the differential element parallel to the x axis is $dA = xdy = y^{\frac{1}{3}}dy$. The coordinates of the centroid for this element are $\bar{x} = \frac{x}{2} = \frac{1}{2}y^{\frac{1}{3}}$, $\bar{y} = y$. Then the product of inertia for this element is

$$dI_{xy} = dI_{cxy} + dA\bar{x}\bar{y}$$

$$= 0 + (y^{\frac{1}{3}}dy) \left(\frac{1}{2}y^{\frac{1}{3}} \right) (y)$$

$$= \frac{1}{2}y^{\frac{5}{3}}dy$$

Product of Inertia: Performing the integration, we have

$$I_{xy} = \int dI_{xy} = \int_0^{1\text{m}} \frac{1}{2}y^{\frac{5}{3}}dy = \frac{3}{16}y^{\frac{8}{3}} \Big|_0^{1\text{m}} = 0.1875 \text{ m}^4 \quad \text{Ans}$$

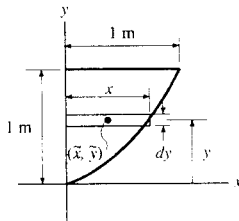

11-1. Use the method of virtual work to determine the tensions in cable AC. The lamp weighs 10 lb.

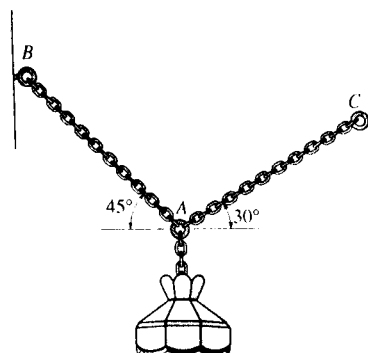

Free Body Diagram : The tension in cable AC can be determined by releasing cable AC. The system has only one degree of freedom defined by the independent coordinate θ . When θ undergoes a positive displacement $\delta\theta$, only F_{AC} and the weight of lamp (10 lb force) do work.

Virtual Displacements : Force F_{AC} and 10 lb force are located from the fixed point B using position coordinates y_A and x_A .

$$x_A = l \cos \theta \quad \delta x_A = -l \sin \theta \delta \theta \quad [1]$$

$$y_A = l \sin \theta \quad \delta y_A = l \cos \theta \delta \theta \quad [2]$$

Virtual - Work Equation : When y_A and x_A undergo positive virtual displacements δy_A and δx_A , the 10 lb force and horizontal component of F_{AC} , $F_{AC} \cos 30^\circ$ do positive work while the vertical component of F_{AC} , $F_{AC} \sin 30^\circ$ does negative work.

$$\delta U = 0; \quad 10 \delta y_A - F_{AC} \sin 30^\circ \delta y_A + F_{AC} \cos 30^\circ \delta x_A = 0 \quad [3]$$

Substituting Eqs. [1] and [2] into [3] yields

$$(10 \cos \theta - 0.5 F_{AC} \cos \theta - 0.8660 F_{AC} \sin \theta) l \delta \theta = 0$$

Since $l \delta \theta \neq 0$, then

$$F_{AC} = \frac{10 \cos \theta}{0.5 \cos \theta + 0.8660 \sin \theta}$$

At the equilibrium position $\theta = 45^\circ$,

$$F_{AC} = \frac{10 \cos 45^\circ}{0.5 \cos 45^\circ + 0.8660 \sin 45^\circ} = 7.32 \text{ lb} \quad \text{Ans}$$

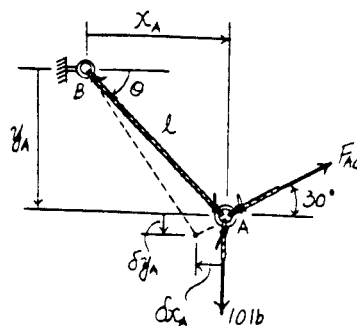

11-2. The uniform rod OA has a weight of 10 lb. When the rod is in vertical position, $\theta = 0^\circ$, the spring is unstretched. Determine the angle θ for equilibrium if the end of the spring wraps around the periphery of the disk as the disk turns.

Free Body Diagram: The system has only one degree of freedom defined by the independent coordinate θ . When θ undergoes a positive displacement $\delta\theta$, only the spring force and the weight of rod (10 lb force) do work.

Virtual Displacements: The 10 lb force is located from the fixed point B using the position coordinate y_B , and the virtual displacement of point C is δx_C .

$$y_B = 1 \cos \theta \quad \delta y_B = -\sin \theta \delta\theta \quad [1]$$

$$\delta x_C = 0.5\delta\theta \quad [2]$$

Virtual—Work Equation: When points B and C undergo positive virtual displacements δy_B and δx_C , the 10 lb force and the spring force F_{sp} , do positive work.

$$\delta U = 0; \quad 10\delta y_B + F_{sp}\delta x_C = 0 \quad [3]$$

Substituting Eqs. [1] and [2] into [3] yields

$$(-10 \sin \theta + 0.5F_{sp}) \delta\theta = 0 \quad [4]$$

However, from the spring formula, $F_{sp} = kx = 30(0.5\theta) = 15\theta$. Substituting this value into Eq. [4] yields

$$(-10 \sin \theta + 7.5\theta) \delta\theta = 0$$

Since $\delta\theta \neq 0$, then

$$-10 \sin \theta + 7.5\theta = 0$$

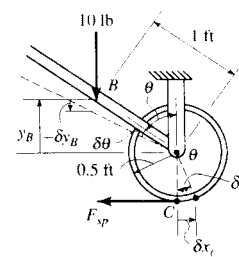
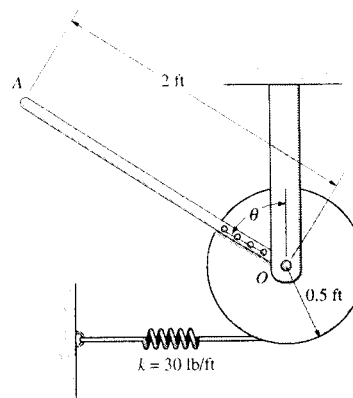

Solving by trial and error

$$\theta = 0^\circ \quad \text{and} \quad \theta = 73.1^\circ$$

Ans

11-3. Determine the force F acting on the cord which is required to maintain equilibrium of the horizontal 10-kg bar AB . *Hint:* Express the total constant vertical length l of the cord in terms of position coordinates s_1 and s_2 . The derivative of this equation yields a relationship between δ_1 and δ_2 .

Free—Body Diagram: Only force F and the weight of link AB (98.1 N) do work.

Virtual Displacements: Force F and the weight of link AB (98.1 N) are located from the top of the fixed link using position coordinates s_2 and s_1 . Since the cord has a constant length, l , then

$$4s_1 - s_2 = l \quad 4\delta s_1 - \delta s_2 = 0 \quad [1]$$

Virtual—Work Equation: When s_1 and s_2 undergo positive virtual displacements δs_1 and δs_2 , the weight of link AB (98.1 N) and force F do positive work and negative work, respectively.

$$\delta U = 0; \quad 98.1(-\delta s_1) - F(-\delta s_2) = 0 \quad [2]$$

Substituting into Eq. [2] into [1] yields

$$(-98.1 + 4F) \delta s_1 = 0$$

Since $\delta s_1 \neq 0$, then

$$-98.1 + 4F = 0$$

$$F = 24.5 \text{ N} \quad \text{Ans}$$

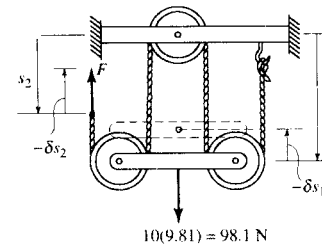
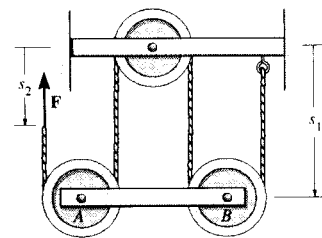

11-4. Each member of the pin-connected mechanism has a mass of 8 kg. If the spring is unstretched when $\theta = 0^\circ$, determine the angle θ for equilibrium. Set $k = 2500 \text{ N/m}$ and $M = 50 \text{ N}\cdot\text{m}$.

$$y_1 = 0.15 \sin \theta$$

$$y_2 = 0.3 \sin \theta$$

$$\delta y_1 = 0.15 \cos \theta \delta \theta$$

$$\delta y_2 = 0.3 \cos \theta \delta \theta$$

$$\delta U = 0; \quad 2(78.48)\delta y_1 + 78.48\delta y_2 - F_2\delta y_2 + 50\delta\theta = 0$$

$$[2(78.48)(0.15 \cos \theta) + 78.48(0.3 \cos \theta) - F_2(0.3 \cos \theta) + 50]\delta\theta = 0$$

$$47.088 \cos \theta - F_2(0.3 \cos \theta) + 50 = 0$$

$$F_2 = 2500(0.3 \sin \theta) = 750 \sin \theta$$

$$47.088 \cos \theta - 112.5 \sin 2\theta + 50 = 0$$

$$\text{Solving, } \theta = 27.4^\circ$$

Ans

$$\text{or } \theta = 72.7^\circ$$

Ans

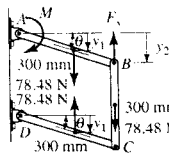
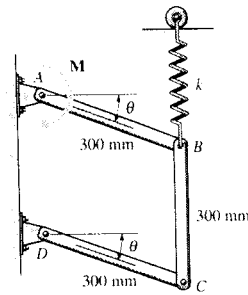

11-5. Each member of the pin-connected mechanism has a mass of 8 kg. If the spring is unstretched when $\theta = 0^\circ$, determine the required stiffness k so that the mechanism is in equilibrium when $\theta = 30^\circ$. Set $M = 0$.

$$y_1 = 0.15 \sin \theta, \quad y_2 = 0.3 \sin \theta$$

$$\delta y_1 = 0.15 \cos \theta \delta \theta, \quad \delta y_2 = 0.3 \cos \theta \delta \theta$$

$$\delta U = 0; \quad 2(78.48)\delta y_1 + 78.48\delta y_2 - F_2\delta y_2 = 0$$

$$[2(78.48)(0.15 \cos \theta) + 78.48(0.3 \cos \theta) - F_2(0.3 \cos \theta)]\delta\theta = 0$$

$$\theta = 30^\circ; \quad F_2 = k(0.3 \sin 30^\circ) = 0.15k$$

$$2(78.48)(0.15 \cos 30^\circ) + 78.48(0.3 \cos 30^\circ)$$

$$- 0.15k(0.3 \cos 30^\circ) = 0$$

$$k = 1.05 \text{ kN/m}$$

Ans

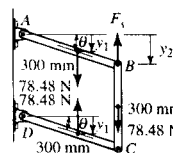
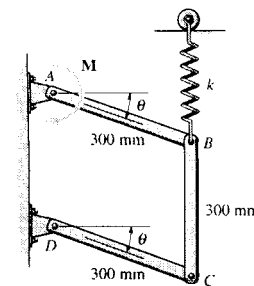

11-6. The crankshaft is subjected to a torque of $M = 50 \text{ N}\cdot\text{m}$. Determine the horizontal compressive force F applied to the piston for equilibrium when $\theta = 60^\circ$.

$$(0.4)^2 = (0.1)^2 + x^2 - 2(0.1)(x)(\cos \theta)$$

$$0 = 0 + 2x\delta x + 0.2x \sin \theta \delta \theta - 0.2 \cos \theta \delta x$$

$$\delta U = 0; \quad -50\delta\theta - F\delta x = 0$$

$$\text{For } \theta = 60^\circ, \quad x = 0.4405 \text{ m}$$

$$\delta x = -0.09769\delta\theta$$

$$(-50 + 0.09769F)\delta\theta = 0$$

$$F = 512 \text{ N}$$

Ans

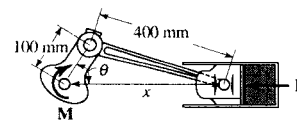
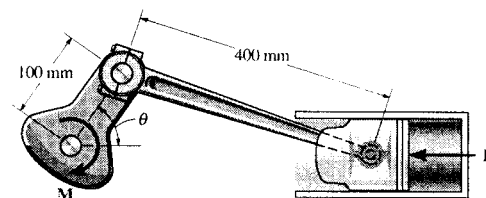

11-7. The crankshaft is subjected to a torque of $M = 50 \text{ N}\cdot\text{m}$. Determine the horizontal compressive force F and plot the result of F (ordinate) versus θ (abscissa) for $0^\circ \leq \theta \leq 90^\circ$.

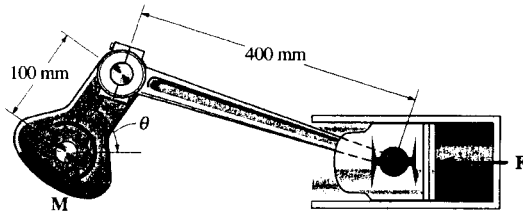

$$(0.4)^2 = (0.1)^2 + x^2 - 2(0.1)(x)(\cos \theta) \quad (1)$$

$$0 = 0 + 2x \delta x + 0.2x \sin \theta \delta \theta - 0.2 \cos \theta \delta x$$

$$\delta x = \left(\frac{0.2x \sin \theta}{0.2 \cos \theta - 2x} \right) \delta \theta$$

$$\delta U = 0; \quad -50 \delta \theta - F \delta x = 0$$

$$-50 \delta \theta - F \left(\frac{0.2x \sin \theta}{0.2 \cos \theta - 2x} \right) \delta \theta = 0, \quad \delta \theta \neq 0$$

$$F = \frac{50(2x - 0.2 \cos \theta)}{0.2x \sin \theta}$$

From Eq. (1)

$$x^2 - 0.2x \cos \theta - 0.15 = 0$$

$$x = \frac{0.2 \cos \theta \pm \sqrt{0.04 \cos^2 \theta + 0.6}}{2}, \quad \text{since } \sqrt{0.04 \cos^2 \theta + 0.6} > 0.2$$

$$x = \frac{0.2 \cos \theta + \sqrt{0.04 \cos^2 \theta + 0.6}}{2}$$

$$F = \frac{500 \sqrt{0.04 \cos^2 \theta + 0.6}}{(0.2 \cos \theta + \sqrt{0.04 \cos^2 \theta + 0.6}) \sin \theta}$$

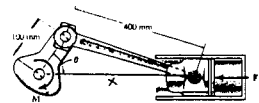

Ans

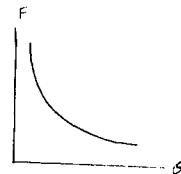

*11-8. Determine the force developed in the spring required to keep the 10 lb uniform rod AB in equilibrium when $\theta = 35^\circ$.

Free-Body Diagram: The system has only one degree of freedom defined by the independent coordinate θ . When θ undergoes a positive displacement $\delta\theta$, only the spring force F_{sp} , the weight of the rod (10 lb) and the 10 lb·ft couple moment do work.

Virtual Displacements: The spring force F_{sp} and the weight of the rod (10 lb) are located from the fixed point A using position coordinates x_B and x_C , respectively.

$$\begin{aligned} x_B &= 6 \cos \theta & \delta x_B &= -6 \sin \theta \delta\theta & [1] \\ y_C &= 3 \sin \theta & \delta y_C &= 3 \cos \theta \delta\theta & [2] \end{aligned}$$

Virtual-Work Equation: When points B and C undergo positive virtual displacements δx_B and δy_C , the spring force F_{sp} and the weight of the rod (10 lb) do negative work. The 10 lb·ft couple moment does negative work when rod AB undergoes a positive virtual rotation $\delta\theta$.

$$\delta U = 0; \quad -F_{sp} \delta x_B - 10 \delta y_C - 10 \delta\theta = 0 \quad [3]$$

Substituting Eqs. [1] and [2] into [3] yields

$$(6F_{sp} \sin \theta - 30 \cos \theta - 10) \delta\theta = 0 \quad [4]$$

Since $\delta\theta \neq 0$, then

$$\begin{aligned} 6F_{sp} \sin \theta - 30 \cos \theta - 10 &= 0 \\ F_{sp} &= \frac{30 \cos \theta + 10}{6 \sin \theta} \end{aligned}$$

At the equilibrium position, $\theta = 35^\circ$. Then

$$F_{sp} = \frac{30 \cos 35^\circ + 10}{6 \sin 35^\circ} = 10.0 \text{ lb} \quad \text{Ans}$$

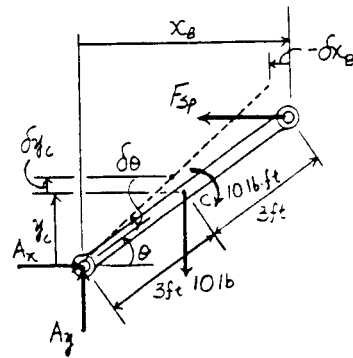
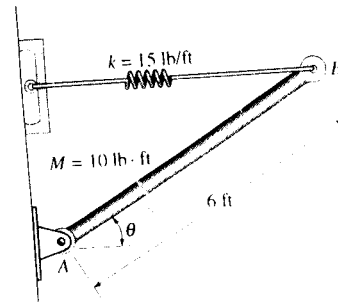

11-9. Determine the angles θ for equilibrium of the 4-lb disk using the principle of the virtual work. Neglect the weight of the rod. The spring is unstretched when $\theta = 0^\circ$ and always remains in the vertical position due to the roller guide.

Free Body Diagram : The system has only one degree of freedom defined by the independent coordinate θ . When θ undergoes a positive displacement $\delta\theta$, only the spring force F_{sp} and the weight of the disk (4 lb) do work.

Virtual Displacements : The spring force F_{sp} and the weight of the disk (4 lb) are located from the fixed point B using position coordinates y_C and y_A , respectively.

$$y_C = 1 \sin \theta \quad \delta y_C = \cos \theta \delta \theta \quad [1]$$

$$y_A = 3 \sin \theta \quad \delta y_A = 3 \cos \theta \delta \theta \quad [2]$$

Virtual-Work Equation : When points C and A undergo positive virtual displacements δy_C and δy_A , the spring force F_{sp} does negative work while the weight of the disk (4 lb) do positive work.

$$\delta U = 0; \quad 4\delta y_A - F_{sp} \delta y_C = 0 \quad [3]$$

Substituting Eqs. [1] and [2] into [3] yields

$$(12 - F_{sp}) \cos \theta \delta \theta = 0 \quad [4]$$

However, from the spring formula, $F_{sp} = kx = 50(1 \sin \theta) = 50 \sin \theta$.

Substituting this value into Eq. [4] yields

$$(12 - 50 \sin \theta) \cos \theta \delta \theta = 0$$

Since $\delta \theta \neq 0$, then

$$12 - 50 \sin \theta = 0 \quad \theta = 13.9^\circ \quad \text{Ans}$$

$$\cos \theta = 0 \quad \theta = 90^\circ \quad \text{Ans}$$

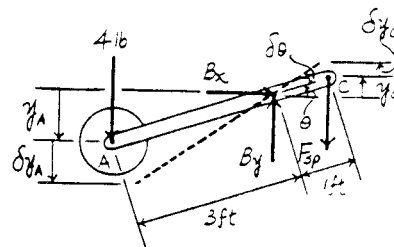
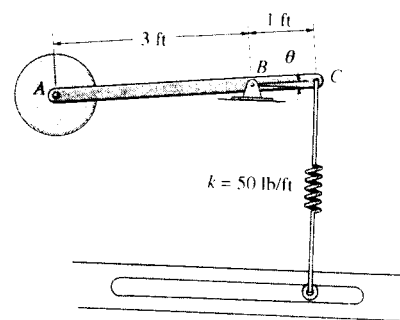

11-10. If each of the three links of the mechanism has a weight of 20 lb, determine the angle θ for equilibrium of the spring, which, due to the roller guide, always remains horizontal and is unstretched when $\theta = 0^\circ$.

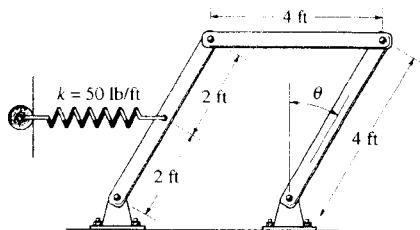

$$x = 2 \sin \theta, \quad \delta x = 2 \cos \theta \delta \theta$$

$$y_1 = 2 \cos \theta, \quad \delta y_1 = -2 \sin \theta \delta \theta$$

$$y_2 = 4 \cos \theta, \quad \delta y_2 = -4 \sin \theta \delta \theta$$

$$\Delta x = 2 \sin \theta$$

$$F_s = k \Delta x = 50(2 \sin \theta) = 100 \sin \theta$$

$$\delta U = 0; \quad -20\delta y_2 - 2(20\delta y_1) - F_s \delta x = 0$$

$$[20(4 \sin \theta) + 2(20)(2 \sin \theta) - F_s(2 \cos \theta)] \delta \theta = 0$$

$$[160 \sin \theta - 200 \sin \theta \cos \theta] \delta \theta = 0$$

$$F_s = k(4 \cos \theta - 4 \cos 45^\circ)$$

$$\text{Hence, } \sin \theta = 0; \quad \theta = 0^\circ \quad \text{Ans}$$

$$\cos \theta = \frac{160}{200}; \quad \theta = 36.9^\circ \quad \text{Ans}$$

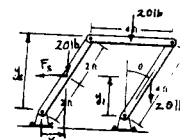

11-11. When $\theta = 20^\circ$, the 50-lb uniform block compresses the two vertical springs 4 in. If the uniform links AB and CD each weigh 10 lb, determine the magnitude of the applied couple moments M needed to maintain equilibrium when $\theta = 20^\circ$.

Free Body Diagram: The system has only one degree of freedom defined by the independent coordinate θ . When θ undergoes a positive displacement $\delta\theta$, only the spring forces F_{sp} , the weight of the block (50 lb), the weights of the links (10 lb) and the couple moment M do work.

Virtual Displacements: The spring forces F_{sp} , the weight of the block (50 lb) and the weight of the links (10 lb) are located from the fixed point C using position coordinates y_3 , y_2 and y_1 respectively.

$$y_3 = 1 + 4 \cos \theta \quad \delta y_3 = -4 \sin \theta \delta\theta \quad [1]$$

$$y_2 = 0.5 + 4 \cos \theta \quad \delta y_2 = -4 \sin \theta \delta\theta \quad [2]$$

$$y_1 = 2 \cos \theta \quad \delta y_1 = -2 \sin \theta \delta\theta \quad [3]$$

Virtual—Work Equation: When y_1 , y_2 and y_3 undergo positive virtual displacements δy_1 , δy_2 and δy_3 , the spring forces F_{sp} , the weight of the block (50 lb) and the weights of the links (10 lb) do negative work. The couple moment M does negative work when the links undergo a positive virtual rotation $\delta\theta$.

$$\delta U = 0; \quad -2F_{sp}\delta y_3 - 50\delta y_2 - 20\delta y_1 - 2M\delta\theta = 0 \quad [4]$$

Substituting Eqs. [1], [2] and [3] into [4] yields

$$(8F_{sp} \sin \theta + 240 \sin \theta - 2M) \delta\theta = 0$$

Since $\delta\theta \neq 0$, then

$$8F_{sp} \sin \theta + 240 \sin \theta - 2M = 0$$

$$M = \sin \theta (4F_{sp} + 120)$$

At the equilibrium position $\theta = 20^\circ$, $F_{sp} = kx = 2(4) = 8$ lb.

$$M = \sin 20^\circ [4(8) + 120] = 52.0 \text{ lb} \cdot \text{ft} \quad \text{Ans}$$

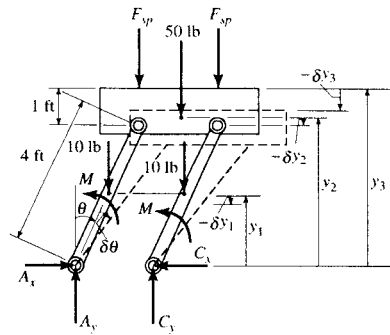
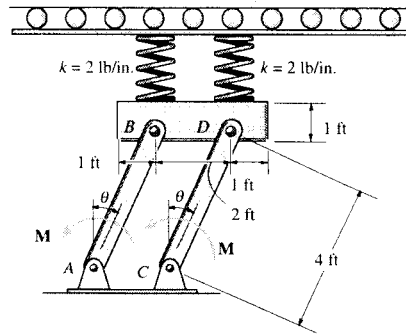

***11-12.** The spring is unstretched when $\theta = 0^\circ$. If $P = 8$ lb, determine the angle θ for equilibrium. Due to the roller guide, the spring always remains vertical. Neglect the weight of the links.

$$y_1 = 2 \sin \theta, \quad \delta y_1 = 2 \cos \theta \delta\theta$$

$$y_2 = 4 \sin \theta + 4, \quad \delta y_2 = 4 \cos \theta \delta\theta$$

$$F_s = 50(2 \sin \theta) = 100 \sin \theta$$

$$\delta U = 0; \quad -F_s \delta y_1 + P \delta y_2 = 0$$

$$-100 \sin \theta (2 \cos \theta \delta\theta) + 8(4 \cos \theta \delta\theta) = 0$$

Assume $\theta < 90^\circ$, so $\cos \theta \neq 0$.

$$200 \sin \theta = 32$$

$$\theta = 9.21^\circ \quad \text{Ans}$$

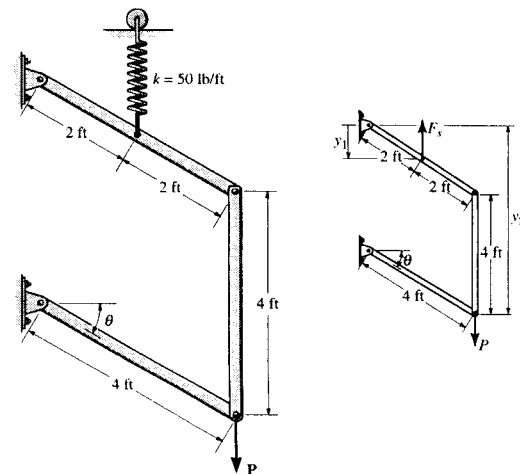

11-13. The thin rod of weight W rest against the smooth wall and floor. Determine the magnitude of force P needed to hold it in equilibrium for a given angle θ .

Free Body Diagram : The system has only one degree of freedom defined by the independent coordinate θ . When θ undergoes a positive displacement $\delta\theta$, only the weight of the rod W and force P do work.

Virtual Displacements : The weight of the rod W and force P are located from the fixed points A and B using position coordinates y_C and x_A , respectively

$$y_C = \frac{l}{2} \sin \theta \quad \delta y_C = \frac{l}{2} \cos \theta \delta\theta \quad [1]$$

$$x_A = l \cos \theta \quad \delta x_A = -l \sin \theta \delta\theta \quad [2]$$

Virtual - Work Equation : When points C and A undergo positive virtual displacements δy_C and δx_A , the weight of the rod W and force P do negative work.

$$\delta U = 0; \quad -W\delta y_C - P\delta x_A = 0 \quad [3]$$

Substituting Eqs. [1] and [2] into [3] yields

$$\left(Pl \sin \theta - \frac{Wl}{2} \cos \theta \right) \delta\theta = 0$$

Since $\delta\theta \neq 0$, then

$$Pl \sin \theta - \frac{Wl}{2} \cos \theta = 0$$

$$P = \frac{W}{2} \cot \theta \quad \text{Ans}$$

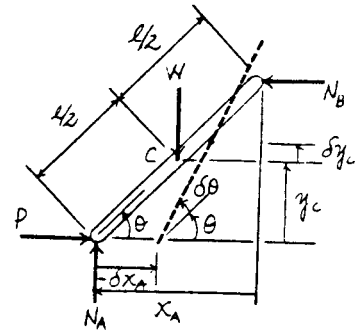
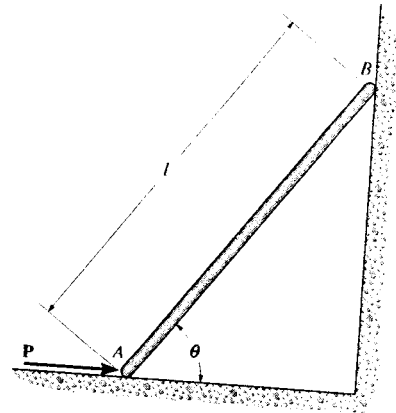

11-14. The 4-ft members of the mechanism are pin-connected at their centers. If vertical forces $P_1 = P_2 = 30$ lb act at C and E as shown, determine the angle θ for equilibrium. The spring is unstretched when $\theta = 45^\circ$. Neglect the weight of the members.

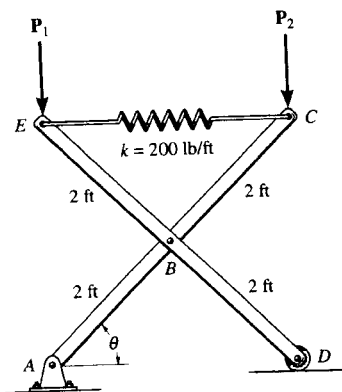

$$y = 4 \sin \theta, \quad x = 4 \cos \theta$$

$$\delta y = 4 \cos \theta \delta\theta, \quad \delta x = -4 \sin \theta \delta\theta$$

$$\delta U = 0; \quad -F_s \delta x - 30 \delta y = 0$$

$$[-F_s(-4 \sin \theta) - 60(4 \cos \theta)] \delta\theta = 0$$

$$F_s = 60 \left(\frac{\cos \theta}{\sin \theta} \right)$$

$$\text{Since } F_s = k(4 \cos \theta - 4 \cos 45^\circ) = 200(4 \cos \theta - 4 \cos 45^\circ)$$

$$60 \cos \theta = 800(\cos \theta - \cos 45^\circ) \sin \theta$$

$$\sin \theta - 0.707 \tan \theta - 0.075 = 0$$

$$\theta = 16.6^\circ \quad \text{Ans}$$

$$\text{and } \theta = 35.8^\circ \quad \text{Ans}$$

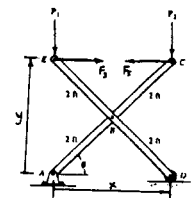

11-15. The spring has an unstretched length of 0.3 m. Determine the angle θ for equilibrium if the uniform links each have a mass of 5 kg.

Free Body Diagram: The system has only one degree of freedom defined by the independent coordinate θ . When θ undergoes a positive displacement $\delta\theta$, only the spring force F_{sp} and the weights of the links (49.05 N) do work.

Virtual Displacements: The position of points B , D and G are measured from the fixed point A using position coordinates x_B , x_D and y_G , respectively.

$$x_B = 0.1 \sin \theta \quad \delta x_B = 0.1 \cos \theta \delta\theta \quad [1]$$

$$x_D = 2(0.7 \sin \theta) - 0.1 \sin \theta = 1.3 \sin \theta \quad \delta x_D = 1.3 \cos \theta \delta\theta \quad [2]$$

$$y_G = 0.35 \cos \theta \quad \delta y_G = -0.35 \sin \theta \delta\theta \quad [3]$$

Virtual—Work Equation: When points B , D and G undergo positive virtual displacements δx_B , δx_D and δy_G , the spring force F_{sp} that acts at point B does positive work while the spring force F_{sp} that acts at point D and the weight of link AC and CE (49.05 N) do negative work.

$$\delta U = 0; \quad 2(-49.05 \delta y_G) + F_{sp}(\delta x_B - \delta x_D) = 0 \quad [4]$$

Substituting Eqs. [1], [2] and [3] into [4] yields

$$(34.335 \sin \theta - 1.2 F_{sp} \cos \theta) \delta\theta = 0 \quad [5]$$

However, from the spring formula, $F_{sp} = kx = 400[2(0.6 \sin \theta) - 0.3] = 480 \sin \theta - 120$. Substituting this value into Eq. [5] yields

$$(34.335 \sin \theta - 576 \sin \theta \cos \theta + 144 \cos \theta) \delta\theta = 0$$

Since $\delta\theta \neq 0$, then

$$34.335 \sin \theta - 576 \sin \theta \cos \theta + 144 \cos \theta = 0$$

$$\theta = 15.5^\circ \quad \text{Ans}$$

$$\text{and } \theta = 85.4^\circ \quad \text{Ans}$$

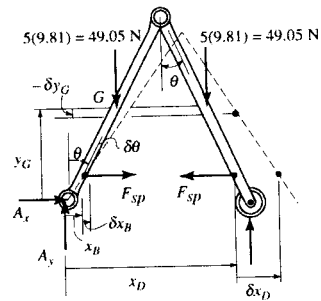
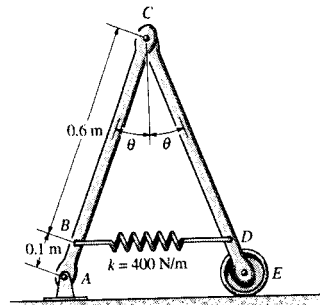

*11-16. Determine the force F needed to lift the block having a weight of 100 lb. *Hint:* Note that the coordinates s_A and s_B can be related to the constant vertical length l of the cord.

$$l = s_A + 2s_B$$

$$\delta s_A = -2\delta s_B$$

$$\delta U = 0; \quad W\delta s_B + F\delta s_A = 0$$

$$100\delta s_B + F(-2\delta s_B) = 0$$

$$F = 50 \text{ lb} \quad \text{Ans}$$

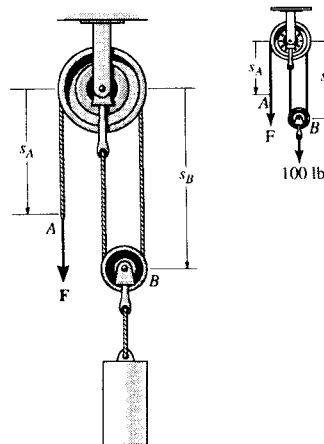

11-17. The machine shown is used for forming metal plates. It consists of two toggles ABC and DEF , which are operated by hydraulic cylinder BE . The toggles push the moveable bar FC forward, pressing the plate p into the cavity. If the force which the plate exerts on the head is $P = 8$ kN, determine the force F in the hydraulic cylinder when $\theta = 30^\circ$.

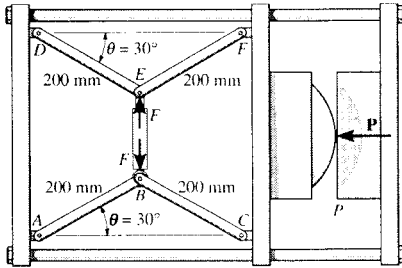

Free Body Diagram: The system has only one degree of freedom defined by the independent coordinate θ . When θ undergoes a positive displacement $\delta\theta$, only the forces F and P do work.

Virtual Displacements: The force F acting on joints E and B and force P are located from the fixed points D and A using position coordinates y_E and y_B , respectively. The location for force P is measured from the fixed point A using position coordinate x_G .

$$y_E = 0.2 \sin \theta \quad \delta y_E = 0.2 \cos \theta \delta\theta \quad [1]$$

$$y_B = 0.2 \sin \theta \quad \delta y_B = 0.2 \cos \theta \delta\theta \quad [2]$$

$$x_G = 2(0.2 \cos \theta) + l \quad \delta x_G = -0.4 \sin \theta \delta\theta \quad [3]$$

Virtual—Work Equation: When points E , B and G undergo positive virtual displacements δy_E , δy_B and δx_G , force F and P do negative work.

$$\delta U = 0; \quad -F\delta y_E - F\delta y_B - P\delta x_G = 0 \quad [4]$$

Substituting Eqs. [1], [2] and [3] into [4] yields

$$(0.4P \sin \theta - 0.4F \cos \theta) \delta\theta = 0$$

Since $\delta\theta \neq 0$, then

$$0.4P \sin \theta - 0.4F \cos \theta = 0 \quad F = P \tan \theta$$

At equilibrium position $\theta = 30^\circ$ set $P = 8$ kN, we have

$$F = 8 \tan 30^\circ = 4.62 \text{ kN} \quad \text{Ans}$$

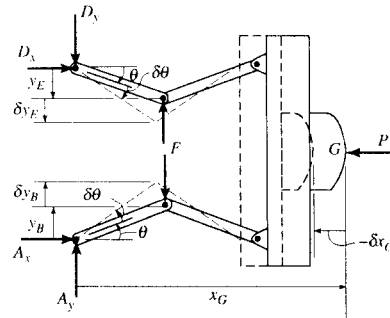

11-18. The vent plate is supported at B by a pin. If it weighs 15 lb and has a center of gravity at G , determine the stiffness k of the spring so that the plate remains in equilibrium at $\theta = 30^\circ$. The spring is unstretched when $\theta = 0^\circ$.

Free Body Diagram : The system has only one degree of freedom defined by the independent coordinate θ . When θ undergoes a positive displacement $\delta\theta$, only the spring force F_{sp} and the weight of the vent plate (15 lb force) do work.

Virtual Displacements : The weight of the vent plate (15 lb force) is located from the fixed point B using the position coordinate y_G . The horizontal and vertical position of the spring force F_{sp} are measured from the fixed point B using the position coordinates x_A and y_A , respectively.

$$y_G = 0.5 \cos \theta \quad \delta y_G = -0.5 \sin \theta \delta \theta \quad [1]$$

$$y_A = 1 \cos \theta \quad \delta y_A = -\sin \theta \delta \theta \quad [2]$$

$$x_A = 1 \sin \theta \quad \delta x_A = \cos \theta \delta \theta \quad [3]$$

Virtual - Work Equation : When y_G , y_A and x_A undergo positive virtual displacements δy_G , δy_A and δx_A , the weight of the vent plate (15 lb force), horizontal component of F_{sp} , $F_{sp} \cos \phi$ and vertical component of F_{sp} , $F_{sp} \sin \phi$ do negative work.

$$\delta U = 0; \quad -F_{sp} \cos \phi \delta x_A - F_{sp} \sin \phi \delta y_A - 15 \delta y_G = 0 \quad [4]$$

Substituting Eqs. [1], [2] and [3] into [4] yields

$$(-F_{sp} \cos \theta \cos \phi + F_{sp} \sin \theta \sin \phi + 7.5 \sin \theta) \delta \theta = 0$$

$$(-F_{sp} \cos(\theta + \phi) + 7.5 \sin \theta) \delta \theta = 0$$

Since $\delta \theta \neq 0$, then

$$-F_{sp} \cos(\theta + \phi) + 7.5 \sin \theta = 0$$

$$F_{sp} = \frac{7.5 \sin \theta}{\cos(\theta + \phi)}$$

At equilibrium position $\theta = 30^\circ$, the angle $\phi = \tan^{-1} \left(\frac{1 \cos 30^\circ}{4 + 1 \sin 30^\circ} \right) = 10.89^\circ$.

$$F_{sp} = \frac{7.5 \sin 30^\circ}{\cos(30^\circ + 10.89^\circ)} = 4.961 \text{ lb}$$

Spring Formula : From the geometry, the spring stretches

$$x = \sqrt{4^2 + 1^2} - 2(4)(1) \cos 120^\circ - \sqrt{4^2 + 1^2} = 0.4595 \text{ ft.}$$

$$F_{sp} = kx$$

$$4.961 = k(0.4595)$$

$$k = 10.8 \text{ lb/ft}$$

Ans

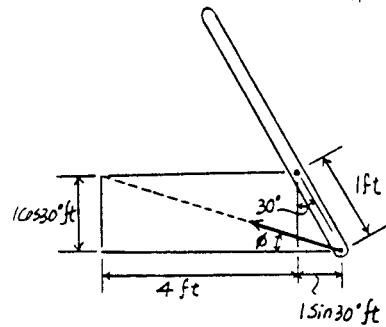
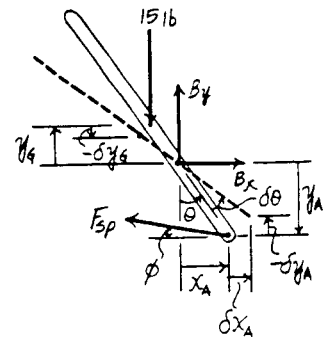
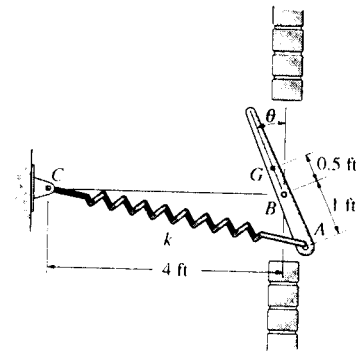

11-19. The scissors jack supports a load P . Determine the axial force in the screw necessary for equilibrium when the jack is in the position θ . Each of the four links has a length L and is pin-connected at its center. Points B and D can move horizontally.

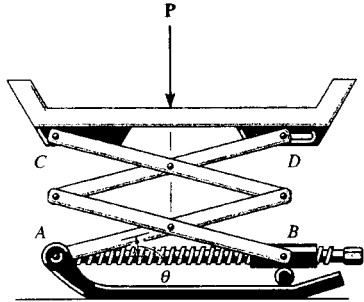

$$x = L \cos \theta, \quad \delta x = -L \sin \theta \delta \theta$$

$$y = 2L \sin \theta, \quad \delta y = 2L \cos \theta \delta \theta$$

$$\delta U = 0; \quad -P \delta y - F \delta x = 0$$

$$-P(2L \cos \theta \delta \theta) - F(-L \sin \theta \delta \theta) = 0$$

$$F = 2P \cot \theta \quad \text{Ans}$$

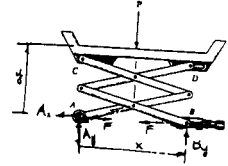

*11-20. Determine the mass of A and B required to hold the 400-g desk lamp in balance for any angles θ and ϕ . Neglect the weight of the mechanism and the size of the lamp.

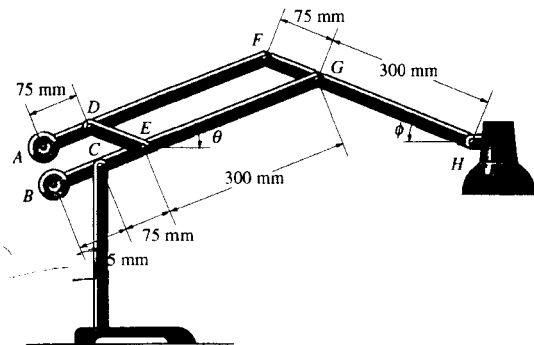

$$y_1 = 300 \sin \phi - 375 \sin \theta$$

$$y_2 = 75 \sin \theta + 75 \sin \phi - 75 \sin \theta = 75 \sin \phi$$

$$y_3 = 75 \sin \theta$$

Displacement $\delta \theta$ (only)

$$\delta y_1 = -375 \cos \theta \delta \theta$$

$$\delta y_2 = 0$$

$$\delta y_3 = 75 \cos \theta \delta \theta$$

$$\delta U = 0; \quad W \delta y_1 - W_A \delta y_2 + W_B \delta y_3 = 0$$

$$W(-375 \cos \theta \delta \theta) - 0 + W_B(75 \cos \theta \delta \theta) = 0$$

$$W_B = \frac{375}{75} W = \frac{375}{75}(0.4)(9.81) = 19.62 \text{ N}$$

$$m_B = \frac{19.62}{9.81} = 2 \text{ kg} \quad \text{Ans}$$

Displacement $\delta \phi$ (only)

$$\delta y_1 = 300 \cos \phi \delta \phi$$

$$\delta y_2 = 75 \cos \phi \delta \phi$$

$$\delta y_3 = 0$$

$$\delta U = 0; \quad W \delta y_1 - W_A \delta y_2 + W_B \delta y_3 = 0$$

$$W(300 \cos \phi \delta \phi) - W_A(75 \cos \phi \delta \phi) + 0 = 0$$

$$W_A = \frac{300}{75} W = \frac{300}{75}(0.4)(9.81) = 15.70 \text{ N}$$

$$m_A = \frac{15.70}{9.81} = 1.60 \text{ kg} \quad \text{Ans}$$

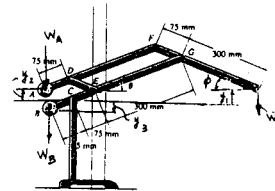

11-21. The piston C moves vertically between the two smooth walls. If the spring has a stiffness of $k = 1.5 \text{ kN/m}$ and is unstretched when $\theta = 0^\circ$, determine the couple M that must be applied to link AB to hold the mechanism in equilibrium; $\theta = 30^\circ$.

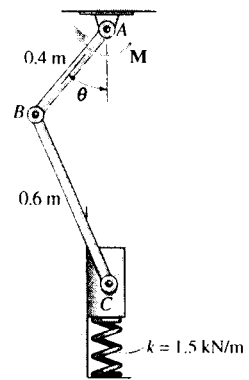

Free Body Diagram : The system has only one degree of freedom defined by the independent coordinate θ . When θ undergoes a positive displacement $\delta\theta$, only the spring force F_{sp} and couple moment M do work.

Virtual Displacements : The spring force F_{sp} is located from the fixed point A using the position coordinate y_C . Using the law of cosines

$$0.6^2 = y_C^2 + 0.4^2 - 2(y_C)(0.4) \cos \theta \quad [1]$$

Differentiating the above expression, we have

$$0 = 2y_C \delta y_C - 0.8 \delta y_C \cos \theta + 0.8 y_C \sin \theta \delta \theta$$

$$\delta y_C = \frac{0.8 y_C \sin \theta}{0.8 \cos \theta - 2y_C} \delta \theta \quad [2]$$

Virtual - Work Equation : When point C undergoes a positive virtual displacement δy_C , the spring force F_{sp} does positive work. The couple moment M does positive work when link AB undergoes a positive virtual rotation $\delta\theta$.

$$\delta U = 0; \quad F_{sp} \delta y_C + M \delta \theta = 0 \quad [3]$$

Substituting Eq. [1] into [2] yields

$$\left(\frac{0.8 y_C \sin \theta}{0.8 \cos \theta - 2y_C} F_{sp} + M \right) \delta \theta = 0$$

Since $\delta\theta \neq 0$, then

$$\frac{0.8 y_C \sin \theta}{0.8 \cos \theta - 2y_C} F_{sp} + M = 0$$

$$M = - \frac{0.8 y_C \sin \theta}{0.8 \cos \theta - 2y_C} F_{sp} \quad [4]$$

At the equilibrium position, $\theta = 30^\circ$. Substituting into Eq. [1],

$$0.6^2 = y_C^2 + 0.4^2 - 2(y_C)(0.4) \cos 30^\circ$$

$$y_C = 0.9121 \text{ m}$$

The spring stretches $x = 1 - 0.9121 = 0.08790 \text{ m}$. Then the spring force is $F_{sp} = kx = 1500(0.08790) = 131.86 \text{ N}$. Substituting the above results into Eq. [4], we have

$$M = - \left[\frac{0.8(0.9121) \sin 30^\circ}{0.8 \cos 30^\circ - 2(0.9121)} \right] 131.86 = 42.5 \text{ N} \cdot \text{m} \quad \text{Ans}$$

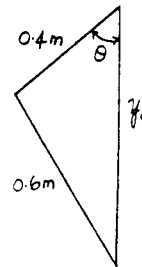
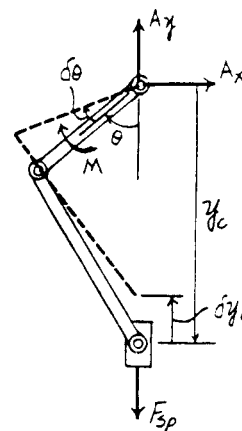

11-22. The crankshaft is subjected to a torque of $M = 50 \text{ lb} \cdot \text{ft}$. Determine the vertical compressive force F applied to the piston for equilibrium when $\theta = 60^\circ$.

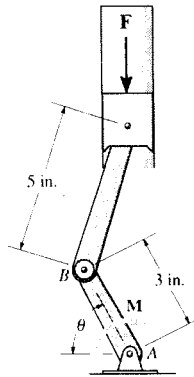

Free Body Diagram: The system has only one degree of freedom defined by the independent coordinate θ . When θ undergoes a positive displacement $\delta\theta$, only the force F and couple moment M do work.

Virtual Displacements: Force F is located from the fixed point A using the positional coordinate y_C . Using the law of cosines.

$$5^2 = y_C^2 + 3^2 - 2(y_C)(3) \cos(90^\circ - \theta) \quad [1]$$

However, $\cos(90^\circ - \theta) = \sin \theta$. Then Eq. [1] becomes $25 = y_C^2 + 9 - 6y_C \sin \theta$. Differentiating this expression, we have

$$0 = 2y_C \delta y_C - 6\delta y_C \sin \theta - 6y_C \cos \theta \delta \theta$$

$$\delta y_C = \frac{6y_C \cos \theta}{2y_C - 6 \sin \theta} \delta \theta \quad [2]$$

Virtual—Work Equation: When point C undergoes a positive virtual displacement δy_C , force F does negative work. The couple moment M does positive work when link AB undergoes a positive virtual rotation $\delta\theta$.

$$\delta U = 0; \quad -F\delta y_C + M\delta\theta = 0 \quad [3]$$

Substituting Eq. [2] into [3] yields

$$\left(-\frac{6y_C \cos \theta}{2y_C - 6 \sin \theta} F + M \right) \delta\theta = 0$$

Since $\delta\theta \neq 0$, then

$$-\frac{6y_C \cos \theta}{2y_C - 6 \sin \theta} F + M = 0$$

$$F = \frac{2y_C - 6 \sin \theta}{6y_C \cos \theta} M \quad [4]$$

At the equilibrium position, $\theta = 60^\circ$. Substituting into Eq. [1], we have

$$5^2 = y_C^2 + 3^2 - 2(y_C)(3) \cos 30^\circ$$

$$y_C = 7.368 \text{ in.}$$

Substituting the above results into Eq. [4] and setting $M = 50 \text{ lb} \cdot \text{ft}$, we have

$$F = \left[\frac{2(7.368) - 6 \sin 60^\circ}{6(7.368) \cos 60^\circ} \right] 50(12 \text{ in./ft}) = 259 \text{ lb} \quad \text{Ans}$$

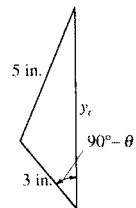
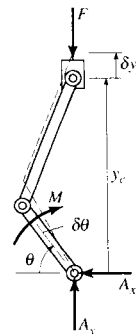

11-23. The assembly is used for exercise. It consists of four pin-connected bars, each of length L , and a spring of stiffness k and unstretched length a ($< 2L$). If horizontal forces \mathbf{P} and $-\mathbf{P}$ are applied to the handles so that θ is slowly decreased, determine the angle θ at which the magnitude of \mathbf{P} becomes a maximum.

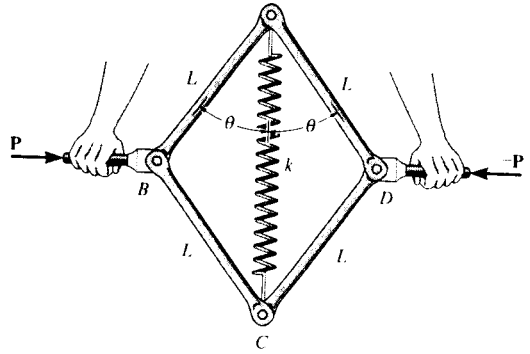

Free Body Diagram : The system has only one degree of freedom defined by the independent coordinate θ . When θ undergoes a positive displacement $\delta\theta$, the spring force F_{sp} and force \mathbf{P} do work.

Virtual Displacements : The spring force F_{sp} and force \mathbf{P} are located from the fixed point D and A using position coordinates y and x , respectively.

$$y = L \cos \theta \quad \delta y = -L \sin \theta \delta \theta \quad [1]$$

$$x = L \sin \theta \quad \delta x = L \cos \theta \delta \theta \quad [2]$$

Virtual - Work Equation : When points A , C , B and D undergo positive virtual displacement δy and δx , the spring force F_{sp} and force \mathbf{P} do negative work.

$$\delta U = 0; \quad -2F_{sp} \delta y - 2P \delta x = 0 \quad [3]$$

Substituting Eqs. [1] and [2] into [3] yields

$$(2F_{sp} \sin \theta - 2P \cos \theta) L \delta \theta = 0 \quad [4]$$

From the geometry, the spring stretches $x = 2L \cos \theta - a$. Then, the spring force $F_{sp} = kx = k(2L \cos \theta - a) = 2kL \cos \theta - ka$. Substituting this value into Eq. [4] yields

$$(4kL \sin \theta \cos \theta - 2ka \sin \theta - 2P \cos \theta) L \delta \theta = 0$$

Since $L \delta \theta \neq 0$, then

$$4kL \sin \theta \cos \theta - 2ka \sin \theta - 2P \cos \theta = 0$$

$$P = k(2L \sin \theta - a \tan \theta)$$

In order to obtain maximum P , $\frac{dP}{d\theta} = 0$.

$$\frac{dP}{d\theta} = k(2L \cos \theta - a \sec^2 \theta) = 0$$

$$\theta = \cos^{-1} \left(\frac{a}{2L} \right)^{\frac{1}{2}} \quad \text{Ans}$$

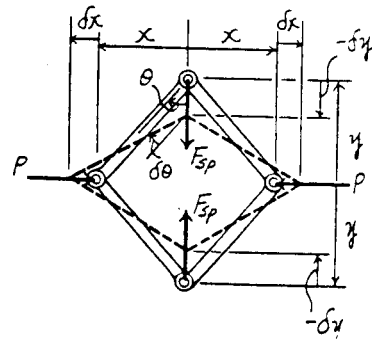

***11-24.** Determine the weight W of the crate if the angle $\theta = 45^\circ$. The springs are unstretched when $\theta = 60^\circ$. Neglect the weights of the members.

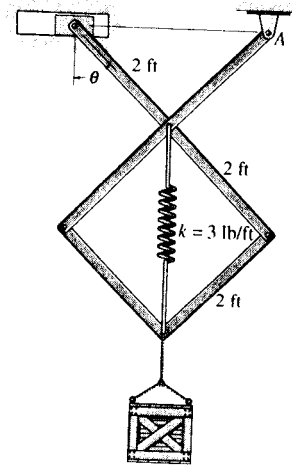

Potential Function : The datum is established at point A. Since the center of gravity of the crate is below the datum, its potential energy is negative. Here, $y = (4\sin \theta + 2\sin \theta) = 6\sin \theta$ ft and the spring stretches $x = 2(2\sin \theta - 2\sin 30^\circ) = (4\sin \theta - 2)$ ft

$$\begin{aligned} V &= V_e + V_s \\ &= \frac{1}{2}kx^2 - Wy \\ &= \frac{1}{2}(3)(4\sin \theta - 2)^2 - W(6\sin \theta) \\ &= 24\sin^2 \theta - 24\sin \theta - 6W\sin \theta + 6 \end{aligned}$$

Equilibrium Position : The system is in equilibrium if $\frac{dV}{d\theta} = 0$.

$$\frac{dV}{d\theta} = 48\sin \theta \cos \theta + 24\cos \theta - 6W\cos \theta = 0 \quad [1]$$

At equilibrium position, $\theta = 45^\circ$. Substituting this value into Eq. [1], we have

$$48\sin 45^\circ \cos 45^\circ + 24\cos 45^\circ - 6W\cos 45^\circ = 0$$

$$W = 1.66 \text{ lb}$$

Ans

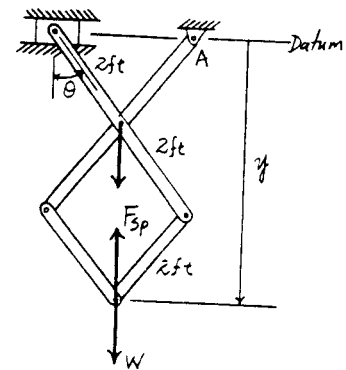

11-25. Rods AB and BC have a center of mass located at their midpoints. If all contacting surfaces are smooth and BC has a mass of 100 kg, determine the appropriate mass of AB required for equilibrium.

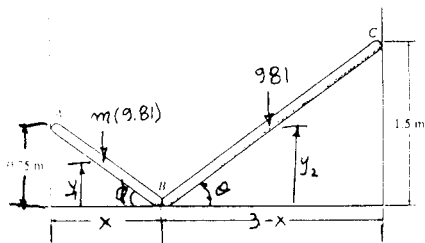
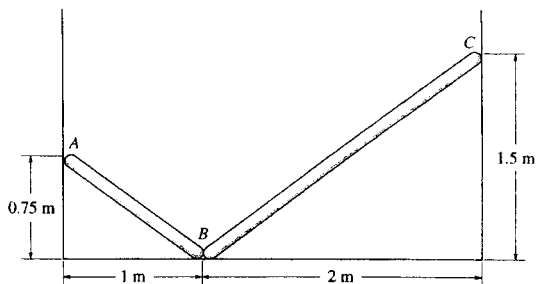

$$x = 1.25 \cos \phi; \quad 3 - x = 2.5 \cos \theta$$

$$3 - 1.25 \cos \phi = 2.5 \cos \theta$$

$$1.25 \sin \phi \delta \phi = -2.5 \sin \theta \delta \theta$$

$$1.25 \left(\frac{0.75}{1.25} \right) \delta \phi = -2.5 \left(\frac{1.5}{2.5} \right) \delta \theta$$

$$0.75 \delta \phi = -1.5 \delta \theta$$

$$\delta \phi = -\delta \theta$$

$$y_1 = \left(\frac{1.25}{2} \right) \sin \phi$$

$$y_2 = 1.25 \sin \theta$$

$$\delta y_1 = 0.625 \cos \phi \delta \phi$$

$$\delta y_2 = 1.25 \cos \theta \delta \theta$$

$$\delta U = 0; \quad -m(9.81) \delta y_1 - 981 \delta y_2 = 0$$

$$-m(9.81)(0.625 \cos \phi \delta \phi) - 981(1.25 \cos \theta \delta \theta) = 0$$

$$-m(9.81)(0.625) \left(\frac{1}{1.25} \right) (-2 \delta \theta) - 981(1.25) \left(\frac{2}{2.5} \right) \delta \theta = 0$$

$$[m(9.81) - 981] \delta \theta = 0$$

$$m = 100 \text{ kg} \quad \text{Ans}$$

11-26. If the potential function for a conservative one-degree-of-freedom system is $V = (8x^3 - 2x^2 - 10) \text{ J}$, where x is given in meters, determine the positions for equilibrium and investigate the stability at each of these positions.

$$V = 8x^3 - 2x^2 - 10$$

$$\frac{dV}{dx} = 24x^2 - 4x = 0$$

$$(24x - 4)x = 0$$

$$x = 0 \quad \text{and} \quad x = 0.167 \text{ m} \quad \text{Ans}$$

$$\frac{d^2V}{dx^2} = 48x - 4$$

$$x = 0, \quad \frac{d^2V}{dx^2} = -4 < 0 \quad \text{Unstable} \quad \text{Ans}$$

$$x = 0.167 \text{ m}, \quad \frac{d^2V}{dx^2} = 4 > 0 \quad \text{Stable} \quad \text{Ans}$$

11-27. If the potential function for a conservative one-degree-of-freedom system is $V = (12 \sin 2\theta + 15 \cos \theta) \text{ J}$, where $0^\circ < \theta < 180^\circ$, determine the positions for equilibrium and investigate the stability at each of these positions.

$$V = 12 \sin 2\theta + 15 \cos \theta$$

$$\frac{dV}{d\theta} = 0; \quad 24 \cos 2\theta - 15 \sin \theta = 0$$

$$24(1 - 2 \sin^2 \theta) - 15 \sin \theta = 0$$

$$48 \sin^2 \theta + 15 \sin \theta - 24 = 0$$

Choosing the angle $0^\circ < \theta < 180^\circ$

$$\theta = 34.6^\circ \quad \text{Ans}$$

and

$$\theta = 145^\circ \quad \text{Ans}$$

$$\frac{d^2V}{d\theta^2} = -48 \sin 2\theta - 15 \cos \theta$$

$$\theta = 34.6^\circ, \quad \frac{d^2V}{d\theta^2} = -57.2 < 0 \quad \text{Unstable} \quad \text{Ans}$$

$$\theta = 145^\circ, \quad \frac{d^2V}{d\theta^2} = 57.2 > 0 \quad \text{Stable} \quad \text{Ans}$$

***11-28.** If the potential function for a conservative one-degree-of-freedom system is $V = (10 \cos 2\theta + 25 \sin \theta) \text{ J}$, where $0^\circ < \theta < 180^\circ$, determine the positions for equilibrium and investigate the stability at each of these positions.

$$V = 10 \cos 2\theta + 25 \sin \theta$$

For equilibrium:

$$\frac{dV}{d\theta} = -20 \sin 2\theta + 25 \cos \theta = 0$$

$$(-40 \sin \theta + 25) \cos \theta = 0$$

$$\theta = \sin^{-1} \left(\frac{25}{40} \right) = 38.7^\circ \text{ and } 141^\circ \quad \text{Ans}$$

and

$$\theta = \cos^{-1} 0 = 90^\circ \quad \text{Ans}$$

$$\text{Stability: } \frac{d^2V}{d\theta^2} = -40 \cos 2\theta - 25 \sin \theta$$

$$\theta = 38.7^\circ, \quad \frac{d^2V}{d\theta^2} = -24.4 < 0, \quad \text{Unstable} \quad \text{Ans}$$

$$\theta = 141^\circ, \quad \frac{d^2V}{d\theta^2} = -24.4 < 0, \quad \text{Unstable} \quad \text{Ans}$$

$$\theta = 90^\circ, \quad \frac{d^2V}{d\theta^2} = 15 > 0, \quad \text{Stable} \quad \text{Ans}$$

11-29. If the potential function for a conservative two-degree-of-freedom system is $V = (9y^2 + 18x^2)$ J, where x and y are given in meters, determine the equilibrium position and investigate the stability at this position.

$$V = 9y^2 + 18x^2$$

$$\frac{\partial V}{\partial x} = 36x = 0; \quad x = 0$$

$$\frac{\partial V}{\partial y} = 18y = 0; \quad y = 0$$

(0,0) is a position for equilibrium **Ans**

$$\frac{\partial^2 V}{\partial x^2} + \frac{\partial^2 V}{\partial y^2} = 36 + 18 = 54 > 0$$

$$\left(\frac{\partial^2 V}{\partial x \partial y}\right)^2 - \left(\frac{\partial^2 V}{\partial x^2}\right)\left(\frac{\partial^2 V}{\partial y^2}\right) = 0 - 36(18) = -648 < 0$$

stable **Ans**

11-30. The spring of the scale has an unstretched length of a . Determine the angle θ for equilibrium when a weight W is supported on the platform. Neglect the weight of the members. What value W would be required to keep the scale in neutral equilibrium when $\theta = 0^\circ$?

Potential Function: The datum is established at point A. Since the weight W is above the datum, its potential energy is positive. From the geometry, the spring stretches $x = 2L \sin \theta$ and $y = 2L \cos \theta$.

$$\begin{aligned} V &= V_s + V_g \\ &= \frac{1}{2} kx^2 + Wy \\ &= \frac{1}{2} (k)(2L \sin \theta)^2 + W(2L \cos \theta) \\ &= 2kL^2 \sin^2 \theta + 2WL \cos \theta \end{aligned}$$

Equilibrium Position: The system is in equilibrium if $\frac{dV}{d\theta} = 0$.

$$\begin{aligned} \frac{dV}{d\theta} &= 4kL^2 \sin \theta \cos \theta - 2WL \sin \theta = 0 \\ \frac{dV}{d\theta} &= 2kL^2 \sin 2\theta - 2WL \sin \theta = 0 \end{aligned}$$

Solving,

$$\theta = 0^\circ \quad \text{or} \quad \theta = \cos^{-1} \left(\frac{W}{2kL} \right) \quad \text{Ans}$$

Stability: To have neutral equilibrium at $\theta = 0^\circ$, $\left. \frac{d^2 V}{d\theta^2} \right|_{\theta=0^\circ} = 0$.

$$\begin{aligned} \frac{d^2 V}{d\theta^2} &= 4kL^2 \cos 2\theta - 2WL \cos \theta \\ \left. \frac{d^2 V}{d\theta^2} \right|_{\theta=0^\circ} &= 4kL^2 \cos 0^\circ - 2WL \cos 0^\circ = 0 \end{aligned}$$

$$W = 2kL \quad \text{Ans}$$

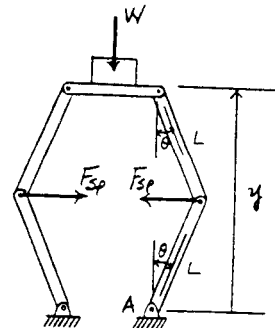
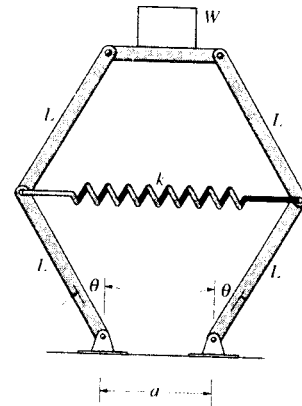

11-31. The two bars each have a weight of 8 lb. Determine the required stiffness k of the spring so that the two bars are in equilibrium when $\theta = 30^\circ$. The spring has an unstretched length of 1 ft.

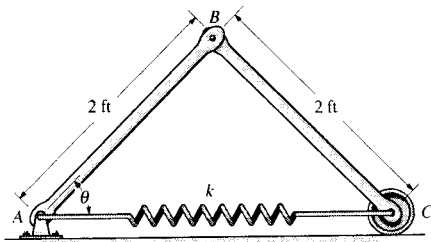

$$V = 2(8)(1 \sin \theta) + \frac{1}{2}k(4 \cos \theta - 1)^2$$

$$\frac{dV}{d\theta} = 16 \cos \theta + k(4 \cos \theta - 1)(-4 \sin \theta)$$

$$\frac{dV}{d\theta} = 16 \cos \theta - 4k(4 \cos \theta - 1) \sin \theta$$

$$\theta = 30^\circ, \quad \frac{dV}{d\theta} = 0$$

$$16 \cos 30^\circ - 4k(4 \cos 30^\circ - 1) \sin 30^\circ = 0$$

$$k = 2.81 \text{ lb/ft}$$

Ans

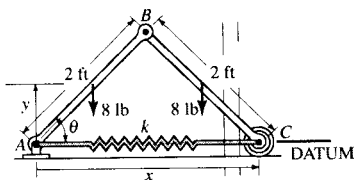

***11-32.** The two bars each have a weight of 8 lb. Determine the angle θ for the equilibrium and investigate the stability at the equilibrium position. The spring has an unstretched length of 1 ft.

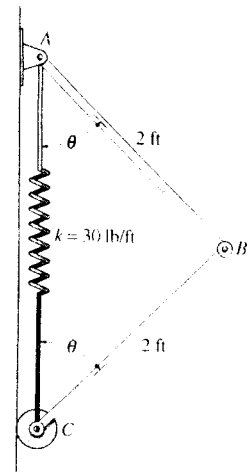

Potential Function : The datum is established at point A. Since the center of gravity of the bars are below the datum, their potential energy is negative. Here, $y_1 = 1 \cos \theta$ ft, $y_2 = 2 \cos \theta + 1 \cos \theta = 3 \cos \theta$ ft and the spring stretches $x = 2(2 \cos \theta) - 1 = (4 \cos \theta - 1)$ ft.

$$\begin{aligned} V &= V_s + V_g \\ &= \frac{1}{2} kx^2 - \Sigma Wy \\ &= \frac{1}{2} (30) (4 \cos \theta - 1)^2 - 8(1 \cos \theta) - 8(3 \cos \theta) \\ &= 240 \cos^2 \theta - 152 \cos \theta + 15 \end{aligned}$$

Equilibrium Position : The system is in equilibrium if $\frac{dV}{d\theta} = 0$.

$$\begin{aligned} \frac{dV}{d\theta} &= -480 \sin \theta \cos \theta + 152 \sin \theta = 0 \\ \frac{dV}{d\theta} &= -240 \sin 2\theta + 152 \sin \theta = 0 \end{aligned}$$

Solving,

$$\theta = 0^\circ \quad \text{or} \quad \theta = 71.54^\circ = 71.5^\circ \quad \text{Ans}$$

Stability :

$$\frac{d^2V}{d\theta^2} = -480 \cos 2\theta + 152 \cos \theta$$

$$\left. \frac{d^2V}{d\theta^2} \right|_{\theta=0^\circ} = -480 \cos 0^\circ + 152 \cos 0^\circ = -328 < 0$$

Thus, the system is in **unstable equilibrium** at $\theta = 0^\circ$ Ans

$$\left. \frac{d^2V}{d\theta^2} \right|_{\theta=71.54^\circ} = -480 \cos 143^\circ + 152 \cos 71.54^\circ = 431.87 > 0$$

Thus, the system is in **stable equilibrium** at $\theta = 71.54^\circ$ Ans

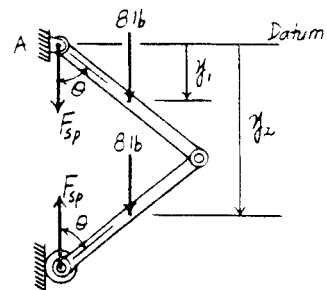

11-33. The truck has a mass of 20 Mg and a mass center at G. Determine the steepest grade θ along which it can park without overturning and investigate the stability in this position.

Potential Function : The datum is established at point A. Since the center of gravity for the truck is above the datum, its potential energy is positive. Here, $y = (1.5 \sin \theta + 3.5 \cos \theta)$ m.

$$V = V_g = Wy = W(1.5 \sin \theta + 3.5 \cos \theta)$$

Equilibrium Position : The system is in equilibrium if $\frac{dV}{d\theta} = 0$

$$\frac{dV}{d\theta} = W(1.5 \cos \theta - 3.5 \sin \theta) = 0$$

Since $W \neq 0$,

$$1.5 \cos \theta - 3.5 \sin \theta = 0$$

$$\theta = 23.20^\circ = 23.2^\circ$$

Ans

Stability :

$$\frac{d^2V}{d\theta^2} = W(-1.5 \sin \theta - 3.5 \cos \theta)$$

$$\left. \frac{d^2V}{d\theta^2} \right|_{\theta=23.20^\circ} = W(-1.5 \sin 23.20^\circ - 3.5 \cos 23.20^\circ) = -3.81W < 0$$

Thus, the truck is in **unstable equilibrium** at $\theta = 23.2^\circ$

Ans

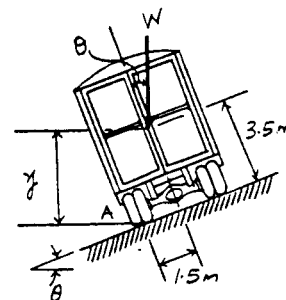
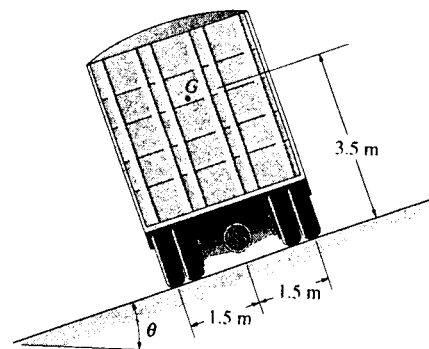

11-34. The bar supports a weight of $W = 500$ lb at its end. If the springs are originally unstretched when the bar is vertical, determine the required stiffness $k_1 = k_2 = k$ of the springs so that the bar is in neutral equilibrium when it is vertical.

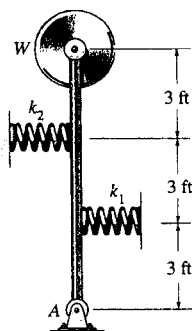

$$y = 9 \cos \theta$$

$$x_1 = 3 \sin \theta$$

$$x_2 = 6 \sin \theta$$

$$V = 500(9 \cos \theta) + \frac{1}{2}k(3 \sin \theta)^2 + \frac{1}{2}k(6 \sin \theta)^2$$

$$V = 4500 \cos \theta + k(22.5 \sin^2 \theta)$$

$$\frac{dV}{d\theta} = -4500 \sin \theta + k(22.5 \sin 2\theta)$$

Require, $\frac{dV}{d\theta} = 0$; $-4500 \sin \theta + k(45 \sin \theta \cos \theta) = 0$

$$\sin \theta = 0; \quad \theta = 0^\circ$$

$$\frac{d^2V}{d\theta^2} = -4500 \cos \theta + k(45 \cos 2\theta)$$

Neutral equilibrium requires $\frac{d^2V}{d\theta^2} = 0$

$$-4500 \cos \theta + k(45 \cos 2\theta) = 0$$

When $\theta = 0^\circ$, $-4500 + 45k = 0$

$$k = 100 \text{ lb/ft} \quad \text{Ans}$$

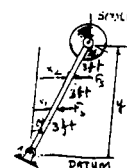

11-35. The cylinder is made of two materials such that it has a mass of m and a center of gravity at point G . Show that when G lies above the centroid C of the cylinder, the equilibrium is unstable.

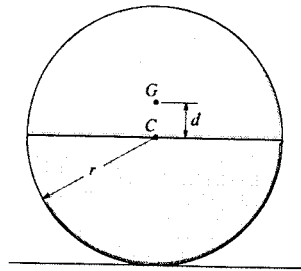

Potential Function: The datum is established at point A . Since the center of gravity of the cylinder is above the datum, its potential energy is positive. Here, $y = r + d \cos \theta$.

$$V = V_g = W_y = mg(r + d \cos \theta)$$

Equilibrium Position: The system is in equilibrium if $\frac{dV}{d\theta} = 0$.

$$\frac{dV}{d\theta} = -mgd \sin \theta = 0$$

$$\sin \theta = 0 \quad \theta = 0^\circ$$

Stability:

$$\frac{d^2V}{d\theta^2} = -mgd \cos \theta$$

$$\left. \frac{d^2V}{d\theta^2} \right|_{\theta=0^\circ} = -mgd \cos 0^\circ = -mgd < 0$$

Thus, the cylinder is in unstable equilibrium at $\theta = 0^\circ$ (Q.E.D.)

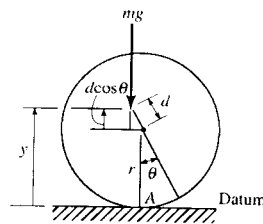

***11-36.** Determine the angle θ for equilibrium and investigate the stability at this position. The bars each have a mass of 3 kg and the suspended block D has a mass of 7 kg. Cord DC has a total length of 1 m.

$$l = 500 \text{ mm}$$

$$y_1 = \frac{1}{2} \sin \theta$$

$$y_2 = l + 2l(1 - \cos \theta) = l(3 - 2 \cos \theta)$$

$$V = 2W y_1 - W_D y_2$$

$$= Wl \sin \theta - W_D l(3 - 2 \cos \theta)$$

$$\frac{dV}{d\theta} = l(W \cos \theta - 2W_D \sin \theta) = 0$$

$$\tan \theta = \frac{W}{2W_D} = \frac{3(9.81)}{14(9.81)} = 0.2143$$

$$\theta = 12.1^\circ$$

Ans

$$\frac{d^2V}{d\theta^2} = l(-W \sin \theta - 2W_D \cos \theta)$$

$$\theta = 12.1^\circ, \quad \frac{d^2V}{d\theta^2} = 0.5[-3(9.81) \sin 12.1^\circ - 14(9.81) \cos 12.1^\circ]$$

$$= -70.2 < 0$$

Unstable

Ans

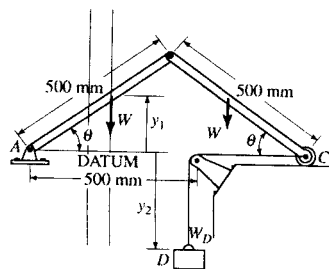
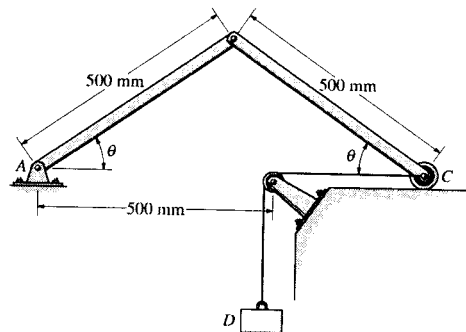

11-37. The cup has a hemispherical bottom and a mass m . Determine the position h of the center of mass G so that the cup is in neutral equilibrium.

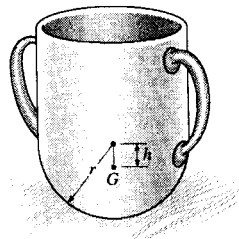

Potential Function: The datum is established at point A . Since the center of gravity of the cup is above the datum, its potential energy is positive. Here, $y = r - h \cos \theta$.

$$V = V_g = W y = mg(r - h \cos \theta)$$

Equilibrium Position: The system is in equilibrium if $\frac{dV}{d\theta} = 0$.

$$\frac{dV}{d\theta} = mgh \sin \theta = 0$$

$$\sin \theta = 0 \quad \theta = 0^\circ$$

Stability: To have neutral equilibrium at $\theta = 0^\circ$, $\left. \frac{d^2V}{d\theta^2} \right|_{\theta=0^\circ} = 0$.

$$\frac{d^2V}{d\theta^2} = mgh \cos \theta$$

$$\left. \frac{d^2V}{d\theta^2} \right|_{\theta=0^\circ} = mgh \cos 0^\circ = 0$$

$$h = 0 \quad \text{Ans}$$

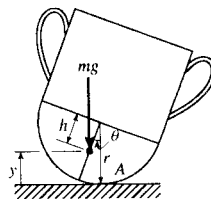

Note: Stable Equilibrium occurs if $h > 0$ ($\left. \frac{d^2V}{d\theta^2} \right|_{\theta=0^\circ} = mgh \cos 0^\circ > 0$).

11-38. If each of the three links of the mechanism has a weight W , determine the angle θ for equilibrium. The spring, which always remains vertical, is unstretched when $\theta = 0^\circ$.

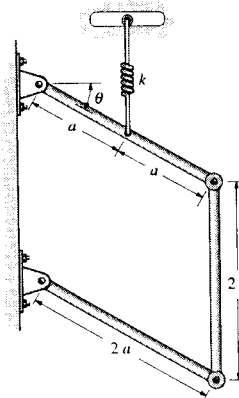

$$y_1 = a \sin \theta \quad \delta y_1 = a \cos \theta \delta \theta$$

$$y_2 = 2a + a \sin \theta \quad \delta y_2 = a \cos \theta \delta \theta$$

$$y_3 = 2a + 2a \sin \theta \quad \delta y_3 = 2a \cos \theta \delta \theta$$

$$F_s = ka \sin \theta$$

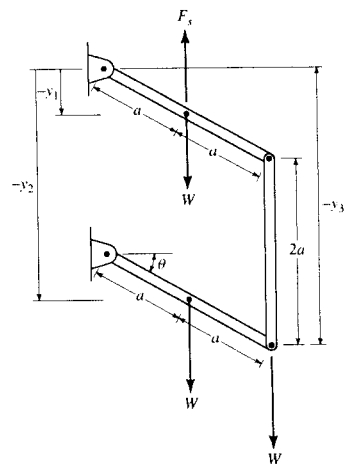

$$\delta U = 0; (W - F_s)\delta y_1 + W\delta y_2 + W\delta y_3 = 0$$

$$(W - ka \sin \theta)a \cos \theta \delta \theta + Wa \cos \theta \delta \theta + W(2a) \cos \theta \delta \theta = 0$$

Assume $\theta < 90^\circ$, so $\cos \theta \neq 0$.

$$4W - ka \sin \theta = 0$$

$$\theta = \sin^{-1} \left(\frac{4W}{ka} \right) \quad \text{Ans}$$

or

$$\theta = 90^\circ \quad \text{Ans}$$

11-39. If the uniform rod OA has a mass of 12 kg, determine the mass m that will hold the rod in equilibrium when $\theta = 30^\circ$. Point C is coincident with B when OA is horizontal. Neglect the size of the pulley at B .

Geometry: Using the law of cosines,

$$l_{AB} = \sqrt{1^2 + 3^2 - 2(1)(3)\cos(90^\circ - \theta)} = \sqrt{10 - 6\sin\theta}$$

$$l_{AB} = \sqrt{1^2 + 3^2} = \sqrt{10} \text{ m}$$

$$l = l_{AB} - l_{A'B} = \sqrt{10} - \sqrt{10 - 6\sin\theta}$$

Potential Function: The datum is established at point O . Since the center of gravity of the rod and the block are above the datum, their potential energy is positive.

Here, $y_1 = 3 - l = [3 - (\sqrt{10} - \sqrt{10 - 6\sin\theta})]$ m and $y_2 = 0.5\sin\theta$ m.

$$V = V_g = W_1 y_1 + W_2 y_2$$

$$= 9.81 \text{ m} [3 - (\sqrt{10} - \sqrt{10 - 6\sin\theta})] + 117.72(0.5\sin\theta)$$

$$= 29.43 \text{ m} - 9.81 \text{ m}(\sqrt{10} - \sqrt{10 - 6\sin\theta}) + 58.86 \sin\theta$$

Equilibrium Position: The system is in equilibrium if

$$\left. \frac{dV}{d\theta} \right|_{\theta=30^\circ} = 0.$$

$$\frac{dV}{d\theta} = -9.81 \text{ m} \left[-\frac{1}{2}(10 - 6\sin\theta)^{-\frac{1}{2}}(-6\cos\theta) \right] + 58.86 \cos\theta$$

$$= -\frac{29.43 \text{ m} \cos\theta}{\sqrt{10 - 6\sin\theta}} + 58.86 \cos\theta$$

At $\theta = 30^\circ$,

$$\left. \frac{dV}{d\theta} \right|_{\theta=30^\circ} = -\frac{29.43 \text{ m} \cos 30^\circ}{\sqrt{10 - 6\sin 30^\circ}} + 58.86 \cos 30^\circ = 0$$

$$m = 5.29 \text{ kg}$$

Ans

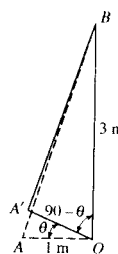
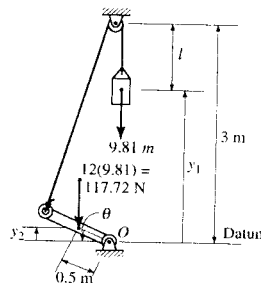
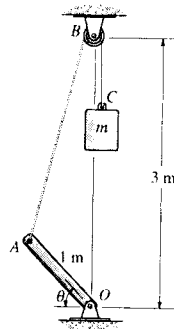

***11-40.** The uniform right circular cone having a mass m is suspended from the cord as shown. Determine the angle θ at which it hangs from the wall for equilibrium. Is the cone in stable equilibrium?

$$V = -\left(\frac{3a}{2}\cos\theta + \frac{a}{4}\sin\theta\right)mg$$

$$\frac{dV}{d\theta} = -\left(-\frac{3a}{2}\sin\theta + \frac{a}{4}\cos\theta\right)mg = 0$$

$$3\sin\theta = 0.5\cos\theta$$

$$\tan\theta = 0.1667$$

$$\theta = 9.46^\circ$$

Ans

$$\frac{d^2V}{d\theta^2} = -\left(-\frac{3a}{2}\cos\theta - \frac{a}{4}\sin\theta\right)mg$$

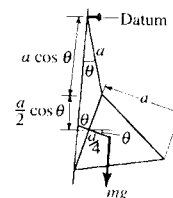
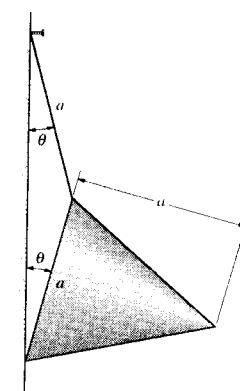

$$\theta = 9.46^\circ, \quad \frac{d^2V}{d\theta^2} = 1.52 a mg > 0$$

Stable

Ans

11-41. The homogeneous cylinder has a conical cavity cut into its base as shown. Determine the depth d of the cavity so that the cylinder balances on the pivot and remains in neutral equilibrium.

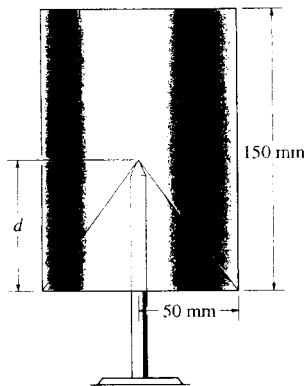

$$\bar{y} = \frac{\Sigma \bar{y}V}{\Sigma V} = \frac{75\pi(50)^2(150) - \frac{d}{4}(\frac{1}{3}\pi)(50)^2 d}{\pi(50)^2(150) - \frac{1}{3}\pi(50)^2 d}$$

$$\bar{y} = \frac{11250 - \frac{d^2}{12}}{150 - \frac{d}{3}}$$

$$y = (\bar{y} - d) \cos \theta$$

$$V = (\bar{y} - d) \cos \theta (W)$$

$$\frac{dV}{d\theta} = -W(\bar{y} - d) \sin \theta = 0$$

$$\theta = 0^\circ \text{ (equilibrium position)}$$

$$\frac{d^2V}{d\theta^2} = -W(\bar{y} - d) \cos \theta = 0$$

$$\text{At } \theta = 0^\circ, \quad \bar{y} = d$$

$$11250 - \frac{d^2}{12} = 150d - \frac{d^2}{3}$$

$$0.25d^2 - 150d + 11250 = 0$$

$$d = 512.1 \text{ mm} > 150 \text{ mm (N.G!)}$$

Also,

$$d = 87.9 \text{ mm} \quad \text{Ans}$$

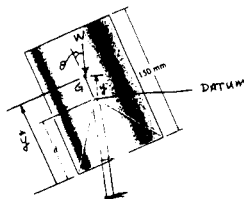

11-42. A homogeneous block rests on top of the cylindrical surface. Derive the relationship between the radius of the cylinder, r , and the dimension of the block, b , for stable equilibrium. *Hint:* Establish the potential energy function for a small angle θ , i.e., approximate $\sin \theta \approx \theta$, and $\cos \theta \approx 1 - \theta^2/2$.

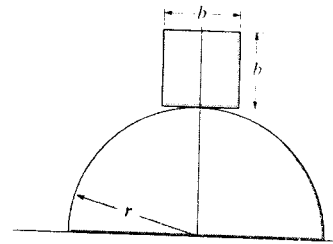

Potential Function : The datum is established at point O . Since the center of gravity for the block is above the datum, its potential energy is positive. Here,

$$y = \left(r + \frac{b}{2}\right) \cos \theta + r\theta \sin \theta.$$

$$V = W_y = W \left[\left(r + \frac{b}{2}\right) \cos \theta + r\theta \sin \theta \right] \quad [1]$$

For small angle θ , $\sin \theta = \theta$ and $\cos \theta = 1 - \frac{\theta^2}{2}$. Then Eq. [1] becomes

$$\begin{aligned} V &= W \left[\left(r + \frac{b}{2}\right) \left(1 - \frac{\theta^2}{2}\right) + r\theta^2 \right] \\ &= W \left(\frac{r\theta^2}{2} - \frac{b\theta^2}{4} + r + \frac{b}{2} \right) \end{aligned}$$

Equilibrium Position : The system is in equilibrium if $\frac{dV}{d\theta} = 0$

$$\frac{dV}{d\theta} = W \left(r - \frac{b}{2} \right) \theta = 0 \quad \theta = 0^\circ$$

Stability : To have stable equilibrium, $\frac{d^2V}{d\theta^2} \Big|_{\theta=0^\circ} > 0$.

$$\frac{d^2V}{d\theta^2} \Big|_{\theta=0^\circ} = W \left(r - \frac{b}{2} \right) > 0$$

$$\left(r - \frac{b}{2} \right) > 0$$

$$b < 2r$$

Ans

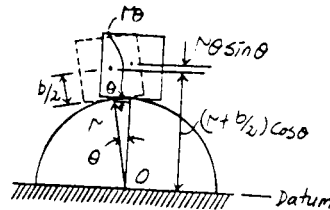

11-43. The homogeneous cone has a conical cavity cut into it as shown. Determine the depth of d of the cavity in terms of h so that the cone balances on the pivot and remains in neutral equilibrium.

$$\bar{y} = \frac{\left(\frac{h}{4}\right)\left(\frac{1}{3}\pi r^2 h\right) - \left(\frac{d}{4}\right)\left(\frac{1}{3}\pi r^2 d\right)}{\frac{1}{3}\pi r^2 h - \frac{1}{3}\pi r^2 d} = \frac{h^2 - d^2}{4(h-d)} = \frac{1}{4}(h+d) \quad [1]$$

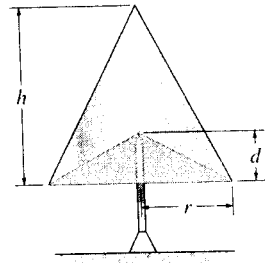

Potential Function : The datum is established at point A. Since the center of gravity of the cone is above the datum, its potential energy is positive. Here,

$$y = (\bar{y} - d) \cos \theta = \left[\frac{1}{4}(h+d) - d \right] \cos \theta = \frac{1}{4}(h-3d) \cos \theta.$$

$$V = W \left[\frac{1}{4}(h-3d) \cos \theta \right] \cos \theta = \frac{W(h-3d)}{4} \cos^2 \theta$$

Equilibrium Position : The system is in equilibrium if $\frac{dV}{d\theta} = 0$

$$\frac{dV}{d\theta} = -\frac{W(h-3d)}{4} \sin \theta = 0$$

$$\theta = 0 \quad \theta = 0^\circ$$

Stability : To have neutral equilibrium at $\theta = 0^\circ$, $\left. \frac{d^2V}{d\theta^2} \right|_{\theta=0^\circ} = 0$.

$$\frac{d^2V}{d\theta^2} = -\frac{W(h-3d)}{4} \cos \theta$$

$$\left. \frac{d^2V}{d\theta^2} \right|_{\theta=0^\circ} = -\frac{W(h-3d)}{4} \cos 0^\circ = 0$$

$$-\frac{W(h-3d)}{4} = 0$$

$$d = \frac{h}{3}$$

Ans

Note : By substituting $d = \frac{h}{3}$ into Eq.[1], one realizes that the fulcrum must be at the center of gravity for neutral equilibrium.

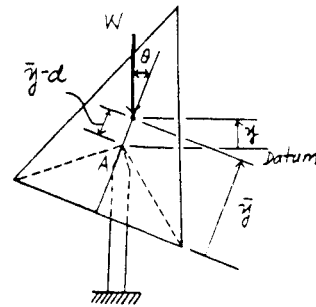
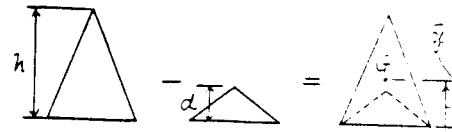

*11-44. The triangular block of weight W rests on the smooth corners which are a distance a apart. If the block has three equal sides of length d , determine the angle θ for equilibrium.

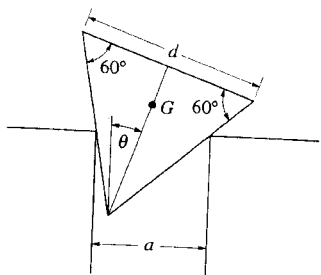

$$AF = AD \sin \phi = AD \sin(60^\circ - \theta)$$

$$\frac{AD}{\sin \alpha} = \frac{a}{\sin 60^\circ}$$

$$AD = \frac{a}{\sin 60^\circ} (\sin(60^\circ + \theta))$$

$$AF = \frac{a}{\sin 60^\circ} (\sin(60^\circ + \theta)) \sin(60^\circ - \theta)$$

$$= \frac{a}{\sin 60^\circ} (0.75 \cos^2 \theta - 0.25 \sin^2 \theta)$$

$$V = Wy$$

$$\frac{dV}{d\theta} = W(-0.5774d) \sin \theta - \frac{a}{\sin 60^\circ} (-1.5 \sin \theta \cos \theta - 0.5 \sin \theta \cos \theta) = 0$$

$$\text{Require, } \sin \theta = 0 \quad \theta = 0^\circ \quad \text{Ans}$$

$$\text{and } -0.5774d - \frac{a}{\sin 60^\circ} (-2 \cos \theta) = 0$$

$$\theta = \cos^{-1} \left(\frac{d}{4a} \right) \quad \text{Ans}$$

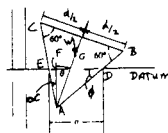

11-45. Two uniform bars, each having a weight W , are pin-connected at their ends. If they are placed over a smooth cylindrical surface, show that the angle θ for equilibrium must satisfy the equation $\cos \theta / \sin^3 \theta = a/2r$.

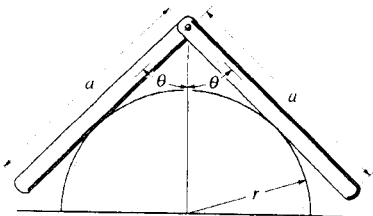

$$V = 2W(r \csc \theta - \frac{a}{2} \cos \theta)$$

$$\frac{dV}{d\theta} = 2W(-r \csc \theta \cot \theta + \frac{a}{2} \sin \theta) = 0$$

$$r \left(\frac{\cos \theta}{\sin^2 \theta} \right) = \frac{a}{2} \sin \theta$$

$$\frac{\cos \theta}{\sin^3 \theta} = \frac{a}{2r} \quad \text{Ans}$$

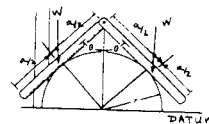

11-46. The uniform links AB and BC each weigh 2 lb and the cylinder weighs 20 lb. Determine the horizontal force P required to hold the mechanism in the position when $\theta = 45^\circ$. The spring has an unstretched length of 6 in.

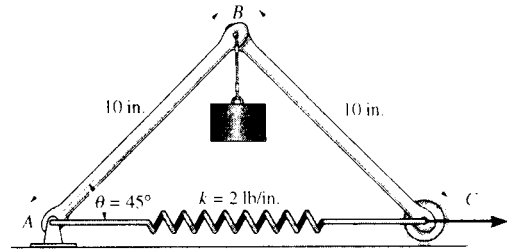

Free Body Diagram: The system has only one degree of freedom defined by the independent coordinate θ . When θ undergoes a positive displacement $\delta\theta$, only the spring force F_p , the weight of links (2 lb), 20 lb force and force P do work.

Virtual Displacements: The positions of points B , D and C are measured from the fixed point A using position coordinates y_B , y_D and x_C respectively.

$$y_B = 10\sin\theta \quad \delta y_B = 10\cos\theta\delta\theta \quad [1]$$

$$y_D = 5\sin\theta \quad \delta y_D = 5\cos\theta\delta\theta \quad [2]$$

$$x_C = 2(10\cos\theta) \quad \delta x_C = -20\sin\theta\delta\theta \quad [3]$$

Virtual-Work Equation: When points B , D and C undergo positive virtual displacements δy_B , δy_D and δx_C , spring force F_p that acts at point C , the weight of links (2 lb) and 20 lb force do negative work while force P does positive work.

$$\delta U = 0; \quad -F_p\delta x_C - 2(2\delta y_D) - 20\delta y_B + P\delta x_C = 0 \quad [4]$$

Substituting Eqs. [1], [2] and [3] into [4] yields

$$(20F_p\sin\theta - 20P\sin\theta - 220\cos\theta)\delta\theta = 0 \quad [5]$$

However, from the spring formula, $F_p = kx = 2[2(10\cos\theta) - 6] = 40\cos\theta - 12$. Substituting this value into Eq. [5] yields

$$(800\sin\theta\cos\theta - 240\sin\theta - 220\cos\theta - 20P\sin\theta)\delta\theta = 0$$

Since $\delta\theta \neq 0$, then

$$800\sin\theta\cos\theta - 240\sin\theta - 220\cos\theta - 20P\sin\theta = 0$$

$$P = 40\cos\theta - 11\cot\theta - 12$$

At the equilibrium position, $\theta = 45^\circ$. Then

$$P = 40\cos 45^\circ - 11\cot 45^\circ - 12 = 5.28 \text{ lb} \quad \text{Ans}$$

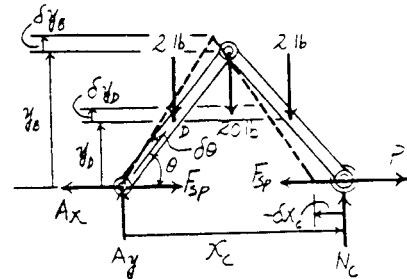

11-47. The spring attached to the mechanism has an unstretched length when $\theta = 90^\circ$. Determine the position θ for equilibrium and investigate the stability of the mechanism at this position. Disk A is pin-connected to the frame at B and has a weight of 20 lb. Neglect the weight of the bars.

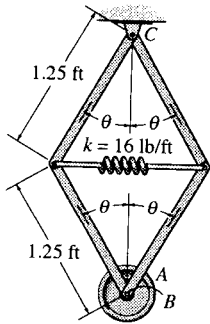

Potential Function: The datum is established at point C . Since the center of gravity of the disk is below the datum, its potential energy is negative. Here, $y = 2(1.25 \cos \theta) = 2.5 \cos \theta$ ft and the spring compresses $x = (2.5 - 2.5 \sin \theta)$ ft.

$$V = V_e + V_g$$

$$= \frac{1}{2} kx^2 - Wy$$

$$= \frac{1}{2} (16)(2.5 - 2.5 \sin \theta)^2 - 20(2.5 \cos \theta)$$

$$= 50 \sin^2 \theta - 100 \sin \theta - 50 \cos \theta + 50$$

Equilibrium Position: The system is in equilibrium if $\frac{dV}{d\theta} = 0$.

$$\frac{dV}{d\theta} = 100 \sin \theta \cos \theta - 100 \cos \theta + 50 \sin \theta = 0$$

$$\frac{dV}{d\theta} = 50 \sin 2\theta - 100 \cos \theta + 50 \sin \theta = 0$$

Solving by trial and error,

$$\theta = 37.77^\circ \approx 37.8^\circ \quad \text{Ans}$$

Stability:

$$\frac{d^2V}{d\theta^2} = 100 \cos 2\theta + 100 \sin \theta + 50 \cos \theta$$

$$\left. \frac{d^2V}{d\theta^2} \right|_{\theta=37.77^\circ} = 100 \cos 75.54^\circ + 100 \sin 37.77^\circ + 50 \cos 37.77^\circ$$

$$= 125.7 > 0$$

Thus, the system is in **stable equilibrium** at $\theta = 37.8^\circ$ **Ans**

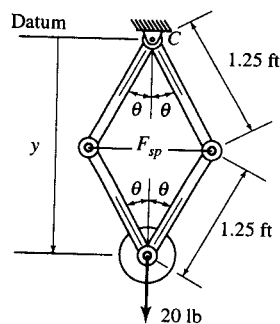

*11-48. The toggle joint is subjected to the load P . Determine the compressive force F it creates on the cylinder at A as a function of θ .

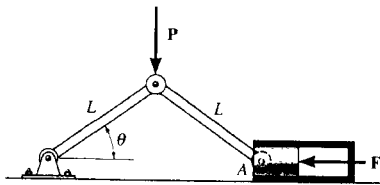

$$x = 2L \cos \theta$$

$$\delta x = -2L \sin \theta \delta \theta$$

$$y = L \sin \theta$$

$$\delta y = L \cos \theta \delta \theta$$

$$\delta U = 0; \quad -P\delta y - F\delta x = 0$$

$$-PL \cos \theta \delta \theta - F(-2L \sin \theta) \delta \theta = 0$$

$$-P \cos \theta + 2F \sin \theta = 0$$

$$F = \frac{P}{2 \tan \theta} \quad \text{Ans}$$

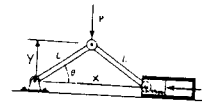

11-49. The uniform beam AB weighs 100 lb. If both springs DE and BC are unstretched when $\theta = 90^\circ$, determine the angle θ for equilibrium using the principle of potential energy. Investigate the stability at the equilibrium position. Both springs always act in the horizontal position because of the roller guides at C and E .

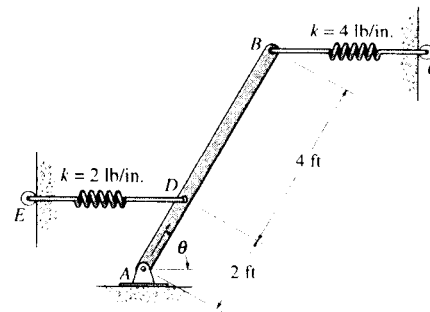

Potential Function : The datum is established at point A . Since the center of gravity of the beam is above the datum, its potential energy is positive. Here, $y = (3 \sin \theta)$ ft, the spring at D stretches $x_D = (2 \cos \theta)$ ft and the spring at B compresses $x = (6 \cos \theta)$ ft.

$$\begin{aligned} V &= V_e + V_s \\ &= \sum \frac{1}{2} kx^2 + Wy \\ &= \frac{1}{2} (24) (2 \cos \theta)^2 + \frac{1}{2} (48) (6 \cos \theta)^2 + 100(3 \sin \theta) \\ &= 912 \cos^2 \theta + 300 \sin \theta \end{aligned}$$

Equilibrium Position : The system is in equilibrium if $\frac{dV}{d\theta} = 0$.

$$\frac{dV}{d\theta} = -1824 \sin \theta \cos \theta + 300 \cos \theta = 0$$

$$\frac{dV}{d\theta} = -912 \sin 2\theta + 300 \cos \theta = 0$$

Solving,

$$\theta = 90^\circ \quad \text{or} \quad \theta = 9.467^\circ = 9.47^\circ$$

Ans

Stability :

$$\frac{d^2 V}{d\theta^2} = -1824 \cos 2\theta - 300 \sin \theta$$

$$\left. \frac{d^2 V}{d\theta^2} \right|_{\theta=90^\circ} = -1824 \cos 180^\circ - 300 \sin 90^\circ = 1524 > 0$$

Thus, the system is in **stable equilibrium** at $\theta = 90^\circ$

Ans

$$\left. \frac{d^2 V}{d\theta^2} \right|_{\theta=9.467^\circ} = -1824 \cos 18.933^\circ - 300 \sin 9.467^\circ = -1774.7 < 0$$

Thus, the system is in **unstable equilibrium** at $\theta = 9.47^\circ$

Ans

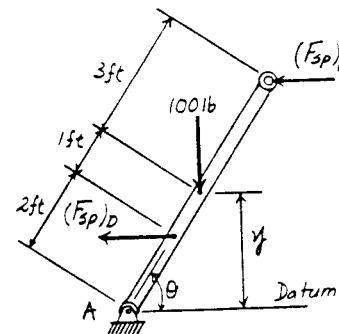

11-50. The uniform bar AB weighs 10 lb. If the attached spring is unstretched when $\theta = 90^\circ$, use the method of virtual work and determine the angle θ for equilibrium. Note that the spring always remains in the vertical position due to the roller guide.

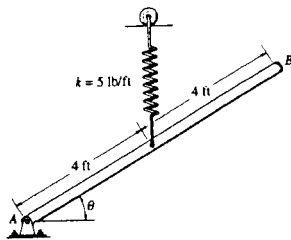

$$y = 4 \sin \theta$$

$$\delta y = 4 \cos \theta \delta \theta$$

$$F_s = 5(4 - 4 \sin \theta)$$

$$\delta U = 0; \quad -10 \delta y + F_s \delta y = 0$$

$$[-10 + 20(1 - \sin \theta)](4 \cos \theta \delta \theta) = 0$$

$$\cos \theta = 0 \quad \text{and} \quad 10 - 20 \sin \theta = 0$$

$$\theta = 90^\circ \quad \theta = 30^\circ \quad \text{Ans}$$

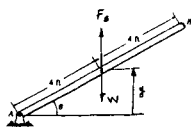

11-51. Solve Prob. 11-50 using the principle of potential energy. Investigate the stability of the bar when it is in the equilibrium position.

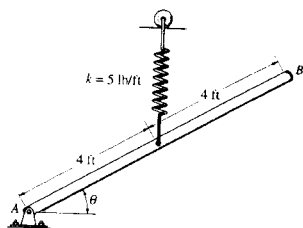

$$y = 4 \sin \theta$$

$$V = 10(4 \sin \theta) + \frac{1}{2}(5)(4 - 4 \sin \theta)^2$$

$$\frac{dV}{d\theta} = 40 \cos \theta + 5(4 - 4 \sin \theta)(-4 \cos \theta)$$

$$\text{Require, } \frac{dV}{d\theta} = 0$$

$$40 \cos \theta - 20(4 - 4 \sin \theta) \cos \theta = 0$$

$$\cos \theta = 0 \quad \text{or} \quad 40 - 80(1 - \sin \theta) = 0$$

$$\theta = 90^\circ, \quad \text{or} \quad \theta = 30^\circ \quad \text{Ans}$$

$$\frac{d^2V}{d\theta^2} = -40 \sin \theta + 5(4 - 4 \sin \theta)(4 \sin \theta) + 5(-4 \cos \theta)(-4 \cos \theta)$$

$$\frac{d^2V}{d\theta^2} = -40 \sin \theta + 80(1 - \sin \theta) \sin \theta + 80 \cos^2 \theta$$

$$\theta = 90^\circ, \quad \frac{d^2V}{d\theta^2} = -40 < 0 \quad \text{Unstable} \quad \text{Ans}$$

$$\theta = 30^\circ, \quad \frac{d^2V}{d\theta^2} = 60 > 0 \quad \text{Stable} \quad \text{Ans}$$

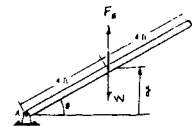

*11-52. The punch press consists of the ram R , connecting rod AB , and a flywheel. If a torque of $M = 50 \text{ N} \cdot \text{m}$ is applied to the flywheel, determine the force F applied at the ram to hold the rod in the position $\theta = 60^\circ$.

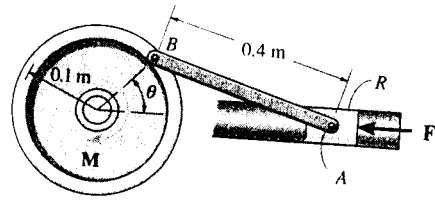

Free Body Diagram : The system has only one degree of freedom defined by the independent coordinate θ . When θ undergoes a positive displacement $\delta\theta$, only force F and $50 \text{ N} \cdot \text{m}$ couple moment do work.

Virtual Displacements : The force F is located from the fixed point A using the position coordinate x_A . Using the law of cosines,

$$0.4^2 = x_A^2 + 0.1^2 - 2(x_A)(0.1) \cos \theta \quad [1]$$

Differentiating the above expression, we have

$$0 = 2x_A \delta x_A - 0.2 \delta x_A \cos \theta + 0.2x_A \sin \theta \delta \theta$$

$$\delta x_A = \frac{0.2x_A \sin \theta}{0.2 \cos \theta - 2x_A} \delta \theta \quad [2]$$

Virtual - Work Equation : When point A undergoes positive virtual displacement δx_A , force F does negative work. The $50 \text{ N} \cdot \text{m}$ couple moment does negative work when the flywheel undergoes a positive virtual rotation $\delta\theta$.

$$\delta U = 0; \quad -F \delta x_A - 50 \delta \theta = 0 \quad [3]$$

Substituting Eq. [2] into [3] yields

$$\left(-\frac{0.2x_A \sin \theta}{0.2 \cos \theta - 2x_A} F - 50 \right) \delta \theta = 0$$

Since $\delta\theta \neq 0$, then

$$-\frac{0.2x_A \sin \theta}{0.2 \cos \theta - 2x_A} F - 50 = 0$$

$$F = -\frac{50(0.2 \cos \theta - 2x_A)}{0.2x_A \sin \theta} \quad [4]$$

At the equilibrium position, $\theta = 60^\circ$. Substituting into Eq. [1], we have

$$0.4^2 = x_A^2 + 0.1^2 - 2(x_A)(0.1) \cos 60^\circ$$

$$x_A = 0.4405 \text{ m}$$

Substituting the above results into Eq. [4], we have

$$F = -\frac{50[0.2 \cos 60^\circ - 2(0.4405)]}{0.2(0.4405) \sin 60^\circ} = 512 \text{ N}$$

Ans

