

PRINCIPLES OF
MEDICAL BIOLOGY

Edited by

E. EDWARD BITTAR
NEVILLE BITTAR

MOLECULAR AND CELLULAR ENDOCRINOLOGY

Molecular and Cellular Endocrinology

PRINCIPLES OF MEDICAL BIOLOGY
A Multi-Volume Work, Volume 10A

*Editors: E. EDWARD BITTAR, Department of Physiology,
University of Wisconsin, Madison*
*NEVILLE BITTAR, Department of Medicine,
University of Wisconsin, Madison*

This Page Intentionally Left Blank

Principles of Medical Biology

A Multi-Volume Work

Edited by **E. Edward Bittar**, *Department of Physiology, University of Wisconsin, Madison* and
Neville Bittar, *Department of Medicine, University of Wisconsin, Madison*

This work provides:

- * A holistic treatment of the main medical disciplines. The basic sciences including most of the achievements in cell and molecular biology have been blended with pathology and clinical medicine. Thus, a special feature is that departmental barriers have been overcome.
- * The subject matter covered in preclinical and clinical courses has been reduced by almost one-third without sacrificing any of the essentials of a sound medical education. This information base thus represents an integrated core curriculum.
- * The movement towards reform in medical teaching calls for the adoption of an integrated core curriculum involving small-group teaching and the recognition of the student as an active learner.
- * There are increasing indications that the traditional education system in which the teacher plays the role of expert and the student that of a passive learner is undergoing reform in many medical schools. The trend can only grow.
- * Medical biology as the new profession has the power to simplify the problem of reductionism.
- * Over 700 internationally acclaimed medical scientists, pathologists, clinical investigators, clinicians and bioethicists are participants in this undertaking.

This Page Intentionally Left Blank

Molecular and Cellular Endocrinology

Edited by **E. EDWARD BITTAR**
Department of Physiology
University of Wisconsin
Madison, Wisconsin

NEVILLE BITTAR
Department of Medicine
University of Wisconsin
Madison, Wisconsin



JAI PRESS INC.

Greenwich, Connecticut

London, England

Library of Congress Cataloging-in-Publication Data

Molecular and cellular endocrinology / edited by E. Edward Bittar,
Neville Bittar.

p. cm. -- (Principles of medical biology ; v. 10A, 10B)

Includes bibliographical references and index.

ISBN 1-55938-815-3

1. Molecular endocrinology. 2. Endocrine glands. 3. Hormones.

I. Bittar, E. Edward. II. Bittar, Neville. III. Series.

QP187.3.M64M616 1997

616.4'07 -- dc21

97-41660

CIP

*Copyright © 1997 by JAI PRESS INC.
55 Old Post Road, No. 2
Greenwich, Connecticut 06836*

*JAI PRESS LTD.
38 Tavistock Street
Covent Garden
London WC2E 7PB
England*

*All rights reserved. No part of this publication may be reproduced,
stored on a retrieval system, or transmitted in any form or by any
means, electronic, mechanical, photocopying, filming, recording or
otherwise without prior permission in writing from the publisher.*

*ISBN: 1-55938-815-3
Library of Congress Catalog No.: 97-41660*

Manufactured in the United States of America

CONTENTS (Volume 10A)

List of Contributors	xi
Preface	
<i>E. Edward Bittar and Neville Bittar</i>	xvii
Chapter 1	
Endocrine Feedback Control in Health and Disease	
<i>Terence J. Wilkin</i>	1
Chapter 2	
Mechanisms of Negative and Positive Feedback of Steroids in the Hypothalamic–Pituitary System	
<i>George Fink</i>	29
Chapter 3	
Corticotropin-Releasing Hormone Neurosecretory Cells: Regulation of Peptide Expression and Release	
<i>Mark H. Whitnall</i>	101
Chapter 4	
Functional Morphology of Hypophysiotropic Hormone-Synthesizing Neurons: Identification, Connectivity, and Plasticity	
<i>István Merchenthaler</i>	119
Chapter 5	
The Pineal Gland	
<i>Russel J. Reiter</i>	145
Chapter 6	
Pituitary–Thyroid Relationships	
<i>James A. Magner</i>	165

Chapter 7

The Parathyroid Gland: Regulation of Production of Parathyroid Hormone

Hitoshi Miki, Jonathan A. van Heerden, and Lorraine A. Fitzpatrick

191

Chapter 8

The Adrenal Medulla

Stephen W. Carmichael

207

Chapter 9

The Adrenal Cortex

Louisa Laue and Gordon B. Cutler, Jr.*

227

Chapter 10

Steroid Hormone and Related Receptors

Hansjörg Keller and Walter Wahli

255

Chapter 11

Enzyme Modulation of Access to Corticosteroid Receptors

Brian R. Walker, Paul M. Stewart, and Christopher R.W. Edwards

297

Chapter 12

Control of Steroid Receptor Function and Gene Expression: The Glucocorticoid Receptor

Jeffrey C. Webster and John A. Cidlowski

311

Chapter 13

Molecular Mechanisms of Thyroid Hormone Action

Kelly D. Davis and Mitchell A. Lazar

321

CONTENTS (Volume 10B)

List of Contributors	xiii
Preface	
<i>E. Edward Bittar and Neville Bittar</i>	xix
Chapter 14	
Insulin and the Insulinlike Growth Factors in Health and Disease	
<i>M. Adamo, C.T. Roberts, Jr., and D. LeRoith</i>	339
Chapter 15	
Molecular Mechanisms in the Pathophysiology of Noninsulin-Dependent Diabetes Mellitus: Insulin Resistance and Insulin Deficiency	
<i>Simeon I. Taylor</i>	365
Chapter 16	
Glucagon: Molecular Biology and Structure-Activity	
<i>Victor J. Hruby</i>	387
Chapter 17	
Somatostatin	
<i>S.W.J. Lamberts, J-C. Reubi, and E.P. Krenning</i>	403
Chapter 18	
The Vasopressin–Oxytocin Systems of the Neurohypophysis	
<i>Gareth Leng and Simon M. Luckman</i>	421
Chapter 19	
Prolactin	
<i>Julian R.E. Davis</i>	439
Chapter 20	
Growth Hormone	
<i>Jens Otto Lunde Jørgensen</i>	451

Chapter 21

Neuropeptide Y: Its Central and Peripheral
Significance to Molecular and Cellular
Endocrinology

Janet M. Allen 467

Chapter 22

Natriuretic Peptides

Rudolf E. Lang 485

Chapter 23

Natriuretic Hormone as a Circulating Inhibitor of
 $\text{Na}^+\text{-K}^+\text{-ATPase}$

Branislav Lichardus and László Kovács 501

Chapter 24

Vasoactive Intestinal Polypeptide

Edwin E. Daniel and Jo-Ann E. T. Fox-Threlkeld 517

Chapter 25

The Mechanisms of Parathyroid Hormone Action

Diarmuid S. O'Riordain and Lorraine A. Fitzpatrick 531

Chapter 26

The Endothelins

William G. Haynes and David J. Webb 543

Chapter 27

Genetic Engineering in the Study of Hormones

Michael Wallis 573

Chapter 28

Genetics and Cell Biology of Calcitonin Action

*Mone Zaidi, Baljit S. Moonga, Michael Pazianas,
Vijai S. Shankar, and Christopher L.H. Huang* 601

Chapter 29

The Genetics and Biology of Vitamin D

Hector F. Deluca 617

Chapter 30

The Tissue Matrix: Cell Signaling and Hormone
Regulation

Robert H. Getzenberg 643

Index

663

LIST OF CONTRIBUTORS

- M. Adamo* Department of Biochemistry
University of Texas Health Science
Center
San Antonio, Texas
- Janet M. Allen* Division of Biochemistry and Molecular
Biology
University of Glasgow
Glasgow, Scotland
- Stephen W. Carmichael* Department of Anatomy
Mayo Clinic/Foundation
Rochester, Minnesota
- John A. Cidlowski* National Institute of Environmental
Health Sciences
National Institutes of Health
Research Triangle Park, North Carolina
- Gordon B. Cutler, Jr.* Child Health and Human Development
National Institutes of Health
Bethesda, Maryland
- Edwin E. Daniel* Department of Biomedical Sciences
McMaster University
Hamilton, Ontario, Canada
- Julian R.E. Davis* Department of Medicine
University of Manchester
Manchester, England
- Kelly D. Davis* Departments of Medicine and Genetics
University of Pennsylvania School of
Medicine
Philadelphia, Pennsylvania

<i>Hector F. DeLuca</i>	Department of Biochemistry University of Wisconsin Madison, Wisconsin
<i>Christopher R.W. Edwards</i>	Department of Medicine University of Edinburgh Edinburgh, Scotland
<i>George Fink</i>	Department of Pharmacology University of Edinburgh Edinburgh, Scotland
<i>Lorraine A. Fitzpatrick</i>	Departments of Internal Medicine and Surgery Mayo Clinic/Foundation Rochester, Minnesota
<i>Jo-Ann E.T. Fox-Threlkeld</i>	Department of Biomedical Sciences McMaster University Hamilton, Ontario, Canada
<i>Robert H. Getzenberg</i>	Pittsburgh Cancer Institute University of Pittsburgh Pittsburgh, Pennsylvania
<i>William G. Haynes</i>	Department of Medicine University of Edinburgh Edinburgh, Scotland
<i>Victor J. Hruby</i>	Department of Chemistry University of Arizona Tucson, Arizona
<i>Christopher L.H. Huang</i>	The Physiological Laboratory University of Cambridge Cambridge, England
<i>Jens Otto Lunde Jørgensen</i>	Endocrinology and Diabetes Department Aarhus Kommunehospital Aarhus, Denmark

- Hansjörg Keller* Institut de Biologie Animale
Université de Lausanne
Lausanne, Switzerland
- László Kovács* Department of Pediatrics
Comenius University Medical School
Bratislava, Slovak Republic
- E.P. Krenning* Departments of Medicine and Nuclear
Medicine
Erasmus University
Rotterdam, The Netherlands
- S.W.J. Lamberts* Departments of Medicine and Nuclear
Medicine
Erasmus University
Rotterdam, The Netherlands
- Rudolf E. Lang* Department of Physiology and
Pathophysiology
Philipps-Universität Marburg
Marburg, Germany
- Louisa Laue** Georgetown University Children's
Medical Center
Washington, District of Columbia
- Mitchell A. Lazar* Departments of Medicine and Genetics
University of Pennsylvania School of
Medicine
Philadelphia, Pennsylvania
- Gareth Leng* Department of Neurobiology
The Babraham Institute
Cambridge, England
- D. LeRoith* Section on Molecular and Cellular
Physiology-Diabetes Branch
National Institutes of Health
Bethesda, Maryland

*Deceased

- Branislav Lichardus* Institute of Experimental Endocrinology
Slovak Academy of Sciences
Bratislava, Slovak Republic
- Simon M. Luckman* Department of Neurobiology
The Babraham Institute
Cambridge, England
- James A. Magner* Bayer Corp.
Pharmaceutical Division
West Haven, Connecticut
- Hitoshi Miki* Departments of Internal Medicine and
Surgery
Mayo Clinic/Foundation
Rochester, Minnesota
- István Merchenthaler* Women's Health Research Institute
Wyeth-Ayerst Research
Radnor, Pennsylvania
- Baljit S. Moonga* VA Medical Center
Philadelphia, Pennsylvania
- Diarmuid S. O'Riordain* St. Vincent's Hospital
Dublin, Ireland
- Michael Pazianas* Division of Biochemical Medicine
St. George's Hospital Medical School
London, England
- Russel J. Reiter* Department of Cellular and Structural
Biology
University of Texas Health Science
Center
San Antonio, Texas
- J-C. Reubi* Departments of Medicine and Nuclear
Medicine
Erasmus University
Rotterdam, The Netherlands

List of Contributors

xv

- C.T. Roberts, Jr.* Section on Molecular and Cellular
Physiology-Diabetes Branch
National Institutes of Health
Bethesda, Maryland
- Vijai S. Shankar* Division of Biochemical Medicine
St. George's Hospital Medical School
London, England
- Paul M. Stewart* Department of Medicine
University of Birmingham
Birmingham, England
- Simeon I. Taylor* Diabetes Branch
National Institutes of Health
Bethesda, Maryland
- Jonathan A. van Heerden* Departments of Internal Medicine and
Surgery
Mayo Clinic/Foundation
Rochester, Minnesota
- Walter Wahli* Institut de Biologie Animale
Université de Lausanne
Lausanne, Switzerland
- Brian R. Walker* Department of Medicine
University of Edinburgh
Edinburgh, Scotland
- Michael Wallis* School of Biological Sciences
University of Sussex
Brighton, England
- David J. Webb* Department of Medicine
University of Edinburgh
Edinburgh, Scotland
- Jeffrey C. Webster* National Institute of Environmental
Health Sciences
National Institutes of Health
Research Triangle Park, North Carolina

Mark H. Whitnall

Radiation Pathophysiology and
Toxicology Department
Armed Forces Radiobiology Research
Institute
Bethesda, Maryland

Terence J. Wilkin

Department of Medicine
University of Plymouth
Plymouth, England

Mone Zaidi

Department of Medicine
VA Medical Center
Philadelphia, Pennsylvania

PREFACE

This two-volume module is written for the medical student as an introduction to the essentials of endocrinology with an emphasis on cellular and molecular processes. It seeks to provide an up-to-date and readable account of a broad and dynamic subject that is developing with great rapidity. Although the material presented is not encyclopedic in scope, it is considered sufficient for use by the tutor to promote an environment for learning. In the interest of the student, we have included some material relating to reproductive endocrinology, a subject that is more completely covered in a module entitled Reproductive Endocrinology and Biology, due to appear in early 1998. This is also the case with gut hormones, which are discussed in the Gastrointestinal Biology module.

The classical era in endocrinology had its beginnings in gastrointestinal physiology when Bayliss and Starling demonstrated, nearly a century ago, that the jejunal segment of the small intestine elaborates a humoral substance (a peptide) that stimulates the release of pancreatic juice. Because they already knew that acid from the stomach also causes pancreatic secretion, they denervated the jejunum and showed that the addition of acid caused the flow of pancreatic juice. They named the putative humoral factor secretin. Three years later, Starling coined the term hormone from the Greek *hormon*, meaning “arouse to activity or excite.”

Though the first half of this century brought gradual progress in clinical endocrinology, two dogmas were in vogue. One was that the endocrine system

consisted of seven ductless glands of internal secretion and the other that the endocrine and nervous systems operated separately. Both have turned out to be misconceptions mainly as the result of the development and application of new and powerful techniques and advances in protein chemistry. Clearly, the rapid expansion of basic endocrinology since the 1960s has led to the acceptance of three major concepts. The first is that the endocrine and nervous systems are united by a rich system of active regulatory peptides of bodywide distribution. This is well illustrated by cholecystokinin [CCK], which is known to act in three modes: as a classical hormone, local regulator, or neurotransmitter. The second concept is that insulin-like growth factors (and somatomedins) act to regulate growth and differentiation in almost every organ. The third is that there is close interaction between the endocrine and immune systems. This has been found to be the case in lymphocytes since they are able to form and secrete peptide hormones, notably endorphins, vasopressin, and IGF, and to respond to hormones.

As editors, we are especially grateful to the various contributors for their unfailing cooperation and patience. Our thanks are also due to Mr. Fred Verhoeven and the staff members of JAI Press for their skill and assistance throughout the production of these two volumes.

E. EDWARD BITTAR
NEVILLE BITTAR

Chapter 1

Endocrine Feedback Control in Health and Disease

TERENCE J. WILKIN

Introduction	2
Control Theory	3
The Neuroendocrine System	3
The Concept of Control	4
Types of Control	4
Control System Design	5
Components of an Endocrine Control System	6
The Control of Thyroid Hormones: The Paradigm for Endocrine Control	7
Experimental Analysis of Control	7
Control Theory and Its Clinical Implications	10
Frequency Distribution of Hormones	10
The Relationship between TSH and TRH	12
The Relationship between TSH and Thyroid Function	15
The Relationship between TSH and Thyroid Function at Different Levels of TRH	15
The Interaction between Pituitary and Thyroid in Producing Control	18

Principles of Medical Biology, Volume 10A
Molecular and Cellular Endocrinology, pages 1–28.
Copyright © 1997 by JAI Press Inc.
All rights of reproduction in any form reserved.
ISBN: 1-55938-815-3

The Clinical Interpretation of Trophin Levels	21
The Endocrine Index	23
The Implications of Hormone Replacement for Hormone Control	25
Positive Feedback	26
Conclusions	27

INTRODUCTION

Feedback control systems are ubiquitous in nature and maintain health as much in microbes as in man. Control loops are designed to constrain a function within a predetermined limit, and failure to do so results in the symptoms and signs we associate with disease. The endocrine system is one category of control system whose function is to constrain the concentrations of substances in the blood such as hormones, glucose, and ions. The endocrine control loop, like any other control loop, comprises two components: a comparator that compares the level of substance being controlled with the set point (optimum level), and a generator which secretes the substance to be controlled. Examples of such control loops are pituitary–thyroid, pituitary–adrenal cortex, islet–liver/muscle, and parathyroid–kidney/bone. Where the set point has a biological rhythm (nycthemeral, circadian, or menstrual), the setting center lies outside the loop (e.g., hypothalamus). Where the set point is constant throughout life (e.g., calcium, glucose, and sodium concentrations), the set point is incorporated within the comparator cells (e.g., parathyroid glands, islet beta cells, and juxtaglomerular apparatus).

Nature has incorporated a particularly elegant modification to feedback control in the form of log–linear transfer functions which confer very special properties upon biological loops. These properties can be explained and predicted by receptor theory which recognizes that the output/input relationships of a gland such as the thyroid are log–linear, and not merely linear. Log–linear response relationships in both components of the feedback loop permit an extremely precise degree of control when small adjustments in output are signaled by a change in a set point. The relationships within a negative feedback loop can be modeled mathematically so as to calculate and display graphically what happens in a loop when diseased, and why. The results of mathematical modeling reveal clinically important aspects of loop behavior. Thus it becomes clear that the concentration of serum TSH (or FSH, or ACTH, or other pituitary trophic hormones) is logarithmically distributed and should therefore be interpreted as such. Similarly, mathematical modeling will explain why there is in a healthy population, contrary to popular belief, no inverse correlation between T4 and TSH. The reason why some patients with apparently normal T4 levels may have TSH levels well above the normal range, while others

do not, can be explained. Of particular clinical importance, the value of careful dosimetry in replacement therapy for endocrine deficiency can be demonstrated.

Medical diagnosis and management, if not always a science, is a rational art. The interpretation of endocrine function tests and the action taken in response to them demands a fundamental understanding of endocrine loop behavior. The principles of feedback loop function are well understood and described here in the context of endocrine disease.

CONTROL THEORY

Endocrinology emerged as a science concerned with hormones secreted directly into the circulation. Hormones were viewed as chemical messengers, conveying signals from one site in the body to another, and their action on target tissues has been studied successively through clinical, cellular-to-molecular levels. Although information of considerable importance has been learned from studies of hormone action, endocrine disturbance in the clinical setting is more commonly associated with disorders of endocrine control than with abnormalities of hormone action.

The Neuroendocrine System

The endocrine system is an extension of the nervous system. Both use secretions to relay information, but whereas the synaptic distances between neurones are measured in micrometers, endocrine signals may travel the length of the body. The interface between nervous and endocrine systems is best illustrated in the hypothalamus and pituitary where two distinct arrangements have evolved. In the case of the posterior pituitary (neurohypophysis), the hormones ADH and vasopressin are elaborated within hypothalamic nerve cells, packaged into complexes and passed by axoplasmic flow to the neurohypophysis where they are released into the systemic circulation. The trophic hormones released from the anterior pituitary (adenohypophysis), by contrast, are elaborated locally in response to neurosecretions relayed from the hypothalamus to the pituitary by a portal blood system. These hypothalamo-pituitary signals, all of them instigated by neuronal activity in the hypothalamus, are ultimately conveyed to the systemic tissues by hormones secreted by the endocrine glands of the body.

Specificity of action in the widely dispersed peripheral nervous system is achieved by precise anatomical connection and a limited number of neurotransmitters. Molecular confusion resulting from the close proximity of nevertheless functionally diverse synapses in the hypothalamus has been avoided by the presence of correspondingly diverse neurotransmitters and neurotransmitter-specific receptors. The endocrine system also relies entirely on receptor specificity, since the pituitary trophins and the hormones they control are indiscriminately mixed in the blood stream.

However, neuroendocrine specificity is not achieved exclusively by anatomical connection or hormone/receptor specificity. GnRH, for example, is effective only when released from the hypothalamus in pulses. Continuous GnRH stimulation causes downregulation of the pituitary response. Furthermore, modulations of the pulse profile and frequency of the GnRH release combine to regulate LH and FSH stimulation independently.

The Concept of Control

Endocrine systems are control systems, but descriptions of their function and operation often confuse the question of what controls, what is being controlled, and what the term “control” implies. There has been a tendency to dissect out the components of a system for study, with consequent failure to take account of their behavior within the intact loop. The medical literature speaks of “... the control of thyroid function” (Purves, 1964), “the control of thyrotrophin ...” (Hershman and Pitman, 1971), “regulation of TSH” (Bogdonove, 1962), “hypothalamic control of thyrotroph–thyroidal function” (Shibusawa et al., 1956), etc. There is nevertheless a simple and universal definition of control which is central to the discussion which follows.

1. *Control is the restraint placed upon a process in order that it perform in a predetermined manner.* Thus, with respect to thyroid function, it is the thyroid hormone concentration in the plasma pool that is being controlled, not the thyroid gland. The restraint is provided by the pituitary–thyroid loop. Di Stefano and Stear (1968) envisaged the pituitary–thyroid loop as controlling a “load.” The load is the tendency for thyroid hormone to disappear from the circulation. This notion of a control loop performing under dynamic strain will become useful later when considering its efficiency. Endocrine systems, however, do not control hormones exclusively; glucose and ions such as calcium and sodium are also subject to endocrine control. Health is assured through good control. Deviation of the substance being controlled from its predetermined concentration in plasma causes the disturbances in tissue function which are expressed as endocrine disease.

2. *Our current understanding of control draws mainly on the science of cybernetics.* The basic concepts are straightforward to explain and employ a terminology which has been developed for the purpose. The same vocabulary, although largely nonmedical, is used here.

Types of Control

Control systems designed to impose restraint may be of the “open” or “closed” loop type. In the “open” type, the input signal V_i is first amplified and the generator then converts the amplified signal (control signal V_c) into a useful form of output, V_o . Perfect control would amount to an output which corresponded exactly to input at all levels of input—i.e. an output which responded in a predetermined manner.

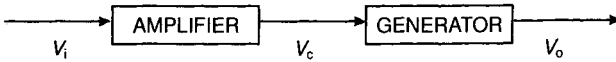

Figure 1a. Open loop control system.

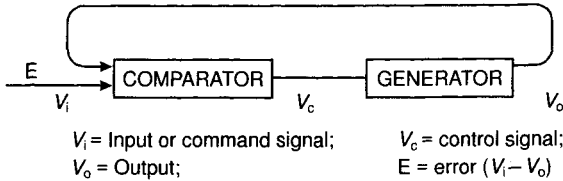

Figure 1b. Closed loop control system.

Such conditions are not obtained in practice, but the incorporation of an amplified input signal was an important step in open loop design because the quality of control improves progressively with the amplification factor or “gain.”

A “closed” loop or servocontrol system differs fundamentally from the open loop type because it senses and automatically responds to any difference between output and input. A servosystem is a combination of elements for control of a generator whose output (hormone, glucose, electrolyte), or some function of it, is fed back for comparison with the input, and the difference between these two quantities is used in controlling the power (Phillips, 1947). The difference between output and input is known as the “error” and servosystems are sometimes referred to as “error-actuated” null devices, implying that the equilibrium they seek is always directed towards minimizing the error. Here, there is an apparent paradox: the larger the error, the more control it can exert over the output, yet the better the control, the smaller the error. The solution, already applied to the open loop system, is to incorporate an amplification factor such that the control signal, although remaining a function of the error, is multiplied many times. In this way considerable restraint can be applied, even as the output approaches input. A further refinement to attain optimal control ensures that changes in error influence the control signal most when the error is least. Nature has achieved this in biological control systems with a logarithmic dose–response curve whose gradient is inversely related to the size of the error. If the error becomes zero, all control is, of course, lost, as there is no signal to activate the loop.

Control System Design

There are three basic designs of servocontrol systems (Hazen, 1934). All are error-actuated, but each responds differently.

1. *Relay type.* The full power of the system is applied as soon as the error is large enough to operate a relay. Unless the relay time is very short, the instability of control may be unacceptable.
2. *Definite correction type.* The power output of the generator is controlled in finite steps and definite time intervals.
3. *Continuous control.* The output is controlled continuously by some function of the error. In the simplest of systems, where all dose–response functions are linear, the generator response would be directly proportional to the error. Biological systems are continuous control systems that incorporate log–linear rather than linear dose–response functions, whose advantages have been mentioned and will become fully apparent later.

Continuous control systems, ubiquitous in nature and widely applied by man, are usually serving one of two purposes: either to ensure that the output faithfully corresponds to a constantly varying input, or to maintain stability of output despite environmental disturbances known as perturbations. Of course, both tasks can be performed simultaneously. The circadian and nycthemeral endocrine rhythms are examples of precise response to a constantly varying input. The maintenance of stable plasma glucose concentrations with each meal is an example of a control system's response to perturbations.

Time constraints are important to the dynamic performance of any control system. Among other subcellular strategies, Nature uses binding proteins of varying affinity and disappearance half-times to modulate the kinetics of hormone flux. The present discussion, however, will be limited to the most elementary analysis of the performance characteristics of a continuous control loop in the steady state, and time constraints can be ignored.

Components of an Endocrine Control System

Continuous control loops comprise two components—a comparator and a generator. The comparator compares the output with input and responds to the difference between them with a control signal which is an amplified function of the error. The control signal drives the generator whose output is in turn an amplified function of the control signal. The input originates outside the loop and is alternatively referred to as the “setting” or the “demand” level. The hypothalamus is a multisystem demand center, the pituitary is a multisystem comparator, and the thyroid, adrenal, gonads, etc. are individual generators. The islet beta-cell–liver and parathyroid–kidney are other examples of control loops, but here the demand centers (which have a fixed rather than variable setting) are located within the comparator, just as the dial of a domestic central heating system (albeit of variable setting) is usually integral with the thermostat.

The Control of Thyroid Hormones: The Paradigm for Endocrine Control

The earliest indication of a functional link between pituitary and thyroid is probably attributable to Niepce (1851) who noted pituitary enlargement in goitrous cretins. Evidence of pituitary influence over thyroid function first derived from the work of Allen (1916) and Smith (1916) in tadpoles. Smith and Smith (1922) were later able to restore metamorphosis in hypophysectomied tadpoles by the injection of homogenized bovine pituitary, providing an elegant demonstration of the thyrotrophic properties of the pituitary. Further support came from Loeb and Basset (1928) and Aron (1929) who independently demonstrated by histological means that bovine pituitary extract stimulated the thyroid. Although Aron et al. (1931) observed a reciprocal relationship between TSH and thyroid hormone (TH), it was Kuschinsky (1933) who concluded that TSH was regulated by TH, and Salter (1940) who supplied the term “pituitary–thyroid” axis.

The intensive research into automatic weapon control systems during World War II (James et al., 1947) seems to have influenced Hoskins (1949) who formally conceived the pituitary–thyroid axis as a servomechanism. In an otherwise unassuming editorial, he outlined the principles of the servocontrol system which have proved the basis for endocrine physiology ever since. One factor, however, eluded Hoskins: the means by which the control mechanism was “set”—the factor that predetermined the level of circulating thyroid hormones.

The existence of a neurovascular link between the hypothalamus and pituitary was recognized by Harris (1948), but first demonstrated by Greer (1951) who observed fundamental disturbances of pituitary influence on the rat thyroid when the hypothalamus was damaged. Experiments on the rabbit, dog, rat, hamster, guinea pig, and ferret (reviewed by Harris, 1955) all suggested that lesions of the anterior basal hypothalamus resulted specifically in a fall of pituitary–thyroid setting.

The only major addition to Hoskins’ original concept has been the experimental observation, first sought by Shibusawa et al. (1956), that hypothalamic TRH effectively “sets” the level at which the thyroxine control loop operates. Following the work of Reichlin et al. (1972) and Vale et al. (1967), there now remains little doubt that the “setting factor” to which Hoskins (1949) referred is hypothalamic TRH.

Experimental Analysis of Control

The quality of control provided by a loop may be expressed as the ratio between its output (V_o) and its input (V_i). This ratio, the most important characteristic of any control system is also called the transfer function, K . That is:

$$K = V_o/V_i \quad (1)$$

The transfer function of a system is its mathematical model. If the transfer function for a particular case is known, the response can be studied for various forms of disturbance. If the transfer function is unknown, it may be measured experimentally by introducing known disturbances and measuring the response of the system. Once established, the transfer function gives a full description of the performance of the system. Perfect control would deliver a transfer function of unity at all levels of input.

A system's transfer function can be deduced generally by solving simultaneously the equations which express the transfer functions of each of its two components. Note that transfer function is really another term for the amplification factor, or gain (g). Thus the transfer functions, g_1 and g_2 of the comparator and generator, respectively, can be expressed thus,

$$g_1 = V_c/E \quad (2)$$

$$g_2 = V_o/V_c \quad (3)$$

where E equals error. Combining the simultaneous Eqs. 2 and 3,

$$g_1 E = V_o/g_2 \quad (4)$$

or

$$g_1 \cdot g_2 E = V_o \quad (5)$$

but $g_1 \cdot g_2 = G$, the overall loop transfer function or loop gain (the factor by which the error signal E is amplified by one circuit of the loop), and,

$$E = V_i - V_o$$

Therefore,

$$G(V_i - V_o) = V_o \quad (6)$$

Alternatively,

$$GV_o + V_o = GV_i \quad (7)$$

or,

$$V_o/V_i = G/G + 1 \quad (8)$$

From Eq. 8 it is clear that the quality of control (V_o/V_i) provided by a simple feedback loop is dependent solely on the value of loop gain (G). Equation 8 can be very simply applied to linear control systems because the loop gain remains constant throughout the range of input, being limited only by saturation of one or either component (at saturation, loop gain falls to zero and all control of output is lost). If, however, the function of one or either component is nonlinear, its gain will

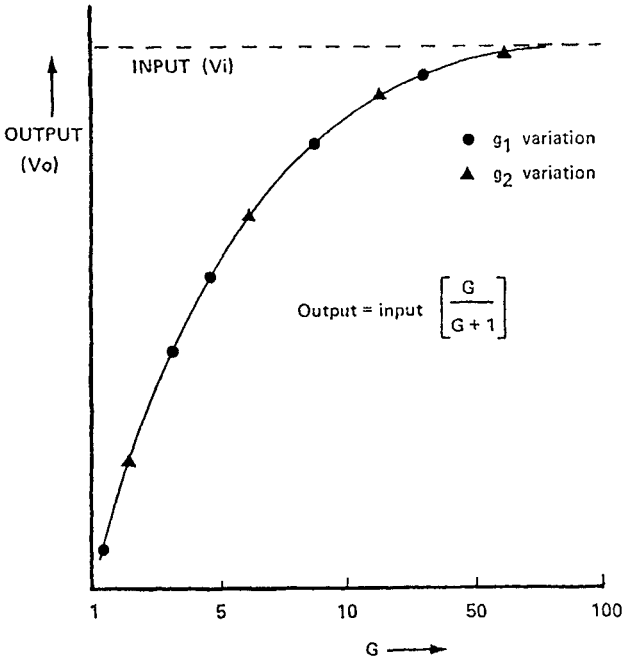

Figure 2. The relationship between quality of control and gain in a closed loop control system. The error (the difference between actual and intended level of output) is a nonlinear function of the loop gain (G) irrespective of whether the variation in G is brought about by changes in comparator (g_1 variation) or generator gain (g_2 variation).

vary according to its input; V_o and G will become interdependent and Eq. 8 consequently insoluble.

Biological responses are mediated by receptors and are mostly log-linear, since the proportion of unoccupied receptors diminishes as the stimulus increases. If this concept seems obscure, consider by analogy the fairground game which sets the task of lobbing balls (molecules of hormone) into the holes (receptors) in a wooden board some distance away (endocrine gland). The stall holder knows full well that the chances of lobbing the next ball into a hole diminishes logarithmically with the number of holes already filled. Now, consider a continuous control system in which the signal undergoes logarithmic transformation at both comparator and generator. Equations 2 and 3 may then be rewritten:

$$g_1 = V_c / \log E \tag{9}$$

$$g_2 = V_o / \log V_c \tag{10}$$

There is now no simple algebraic solution to the equations, and resort has to be made to a root-finding algorithm. A likely solution (value of V_o for a given V_i and gain) is estimated and tried. If the solution is correct, the answer to the equations will approximate to zero; if not, the answer will indicate sign and size of the error. Fortunately, such equations can be solved very rapidly by a suitably programmed digital computer. Such a program, however, will clearly amount to no more than a mathematical null device: a numerical analog of the original control system whose function is likewise to find a solution (V_o) which will reduce the error to a prescribed tolerance. That tolerance is defined by the loop gain. If G is very high, the solution to the equation will be very close to V_i . If the loop gain G falls— V_o diverges from V_i —the error tolerated by the system rises and with it the control signal V_c . The only limitation on these relationships is saturation of one or other component which will immediately reduce loop gain to zero. With zero loop gain control lost, output no longer bears a relation to input, and the control loop has “failed.”

A log-linear control loop is therefore consigned a point of equilibrium determined by V_i and the error the loop will tolerate. This concept is fundamental to biological control systems, and can be expressed graphically by the intercept of the plots expressing the simultaneous equations which describe the two components of the loop (Figure 2). The proximity of the intercept to V_i is solely a function of loop gain.

In summary, whether linear or not, continuous control feedback loops share the following features: first, they attempt to reduce the error between output and input towards zero irrespective of disturbances such as change in input, output loads, or characteristics of comparator or generator. Second, the quality of control depends solely on loop gain. Third, the best tests of a control system's function are the responses either to a change in input level or to a change in output load.

CONTROL THEORY AND ITS CLINICAL IMPLICATIONS

Health depends largely on homeostasis, and ill-health may be regarded as the symptom of disordered control. The principles of control ultimately determine the pattern of disease, and clinical biochemistry provides the means of measurement.

Frequency Distribution of Hormones

Control theory based on the principles outlined for a biological system would predict a Gaussian (normal) distribution for the output of the loop and a logarithmic (skewed) distribution for the control signal within it. Clinical observation appears to bear this out (Figure 3). Experimental confirmation of the theoretical relationships between TRH, TSH, and TH at the pituitary level is less simple. The work of Vale et al. (1967) first suggested some form of competition between TRH and TH at the pituitary level, and this has received more than ample support from the measurement of TSH responses to injections of synthetic TRH, to variations in TH,

and to both. The TSH release in response to TRH clearly followed a log-linear dose-response curve.

The generation of comparable data for adjustments in TH levels is even more problematic. It is necessary first to "open" the control loop, otherwise graded increments of administered TH will not (by the nature of loop behavior) result in corresponding increments of plasma TH. A (inverse) log-linear relationship between TSH and incremental TH was nevertheless clearly demonstrated in hypothyroid humans (Utiger and Reichlin, 1966) and thyroidectomized rats (Reichlin et al., 1970).

Experimental evidence would therefore seem to confirm that the influences of both TRH and TH on the pituitary are logarithmic. This situation appears to be analogous to the competitive inhibition shown between drug agonist and antagonist, where the eventual response is proportional to the difference in the log concentrations of each (which mathematically is the same as the log of their ratio). A change in concentration of either merely displaces the TSH response curve to the left or to

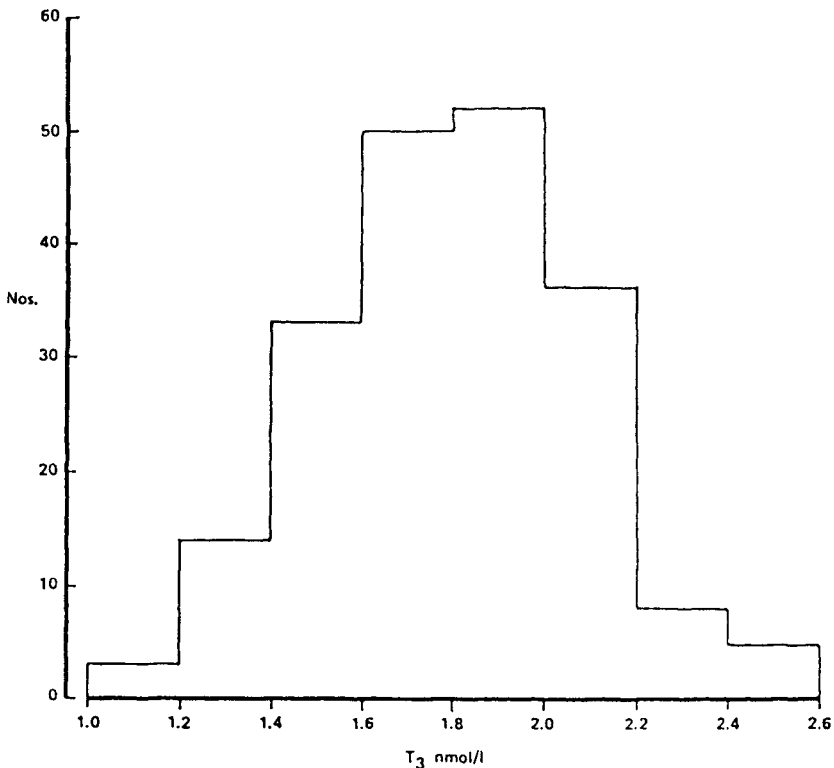

Figure 3a. The frequency distribution of total serum T₃ in 188 normal adults.

the right, but does not alter its gradient (a change in g_1 would be needed to alter the gradient). Such displacements in pharmacological terms are analogous to the changes in “setting” resulting from variation in TRH. When a fall in TRH was induced experimentally by hypothalamic damage in rats, the dose–response curve of TSH/TH was duly displaced to the left (Reichlin et al., 1972).

With these relationships established, it is possible to predict the clinical behavior of an endocrine control and compare that prediction with clinical observation. In the clinical situations which follow, the hypothalamic–pituitary–thyroid system is used as the paradigm and calculations are based on log–linear relationships at pituitary and thyroid.

The Relationship between TSH and TRH

The distribution of T4 in a healthy population is symmetrical (Figure 3b). When the clinically observed distribution of T4 is simulated by varying the demand level of TRH, using the mathematical relationships established earlier, the corresponding

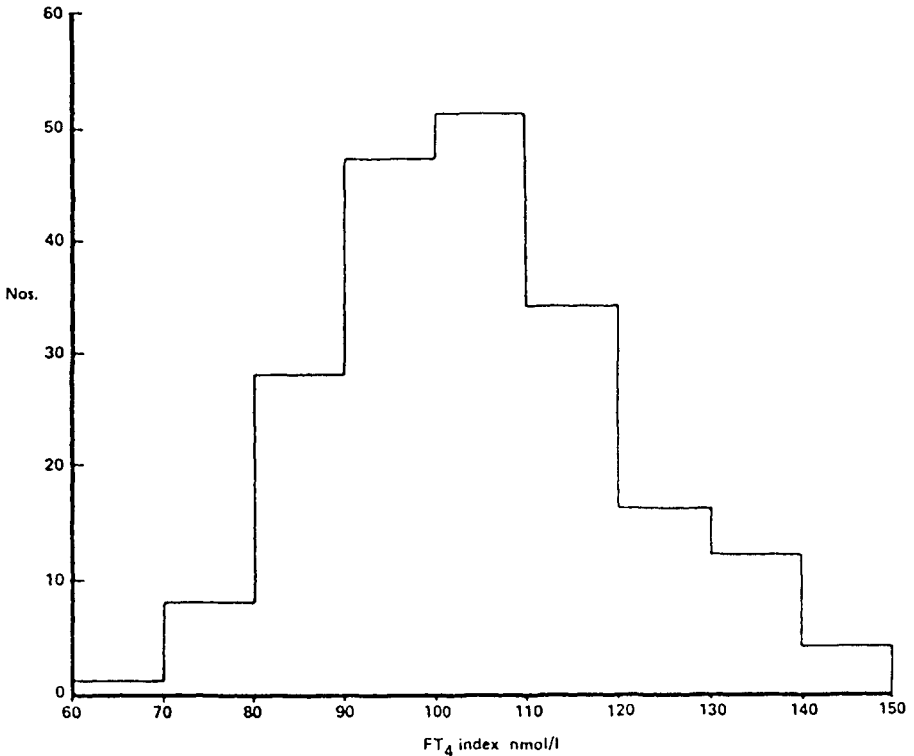

Figure 3b. The frequency distribution of FT4 index in 188 normal adults.

distribution of TSH is skewed to the left (Figure 4). This log-Gaussian distribution is observed in practice (Figure 3c). Accordingly, TSH should be regarded—and analyzed—as a logarithmically distributed variable. Furthermore, there appears to be a variation of TSH in health which is related to the natural (TRH-mediated) variation in T4 and independent of thyroid function. In control terms, this implies (predictably) that the quality of control falls when a rising TRH level places an increasing demand upon the loop. Specifically, the higher TSH at higher T4 levels reflects the loss of loop gain which results when a loop dependent on log-linear responses is driven harder.

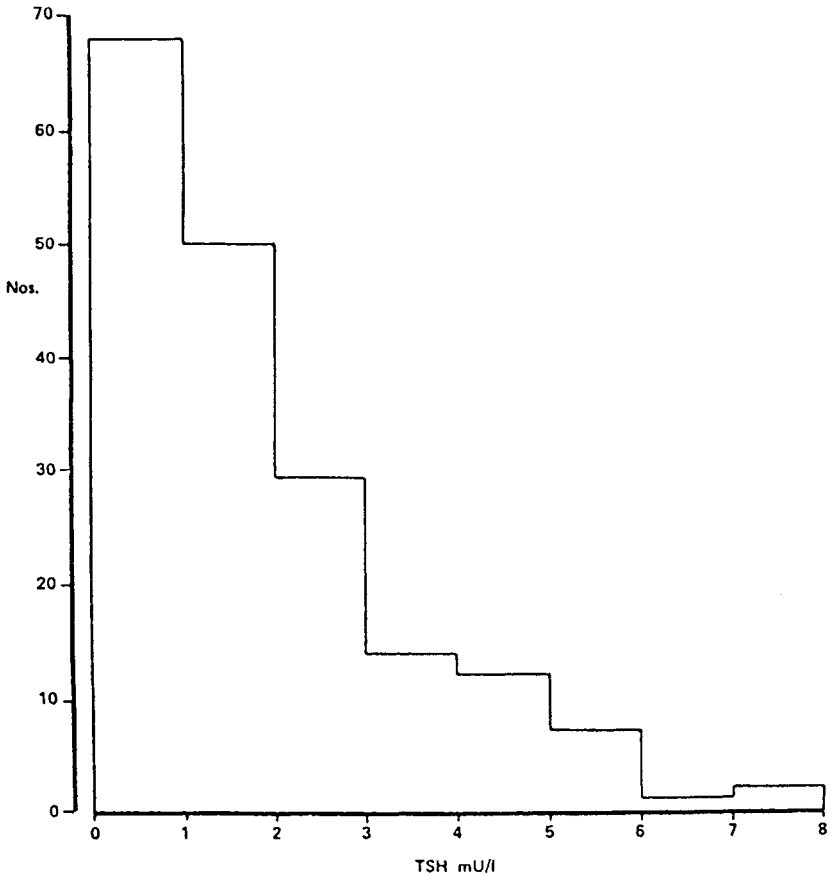

Figure 3c. The frequency distribution of serum TSH in 188 normal adults (assay sensitivity 0.5 mU/L).

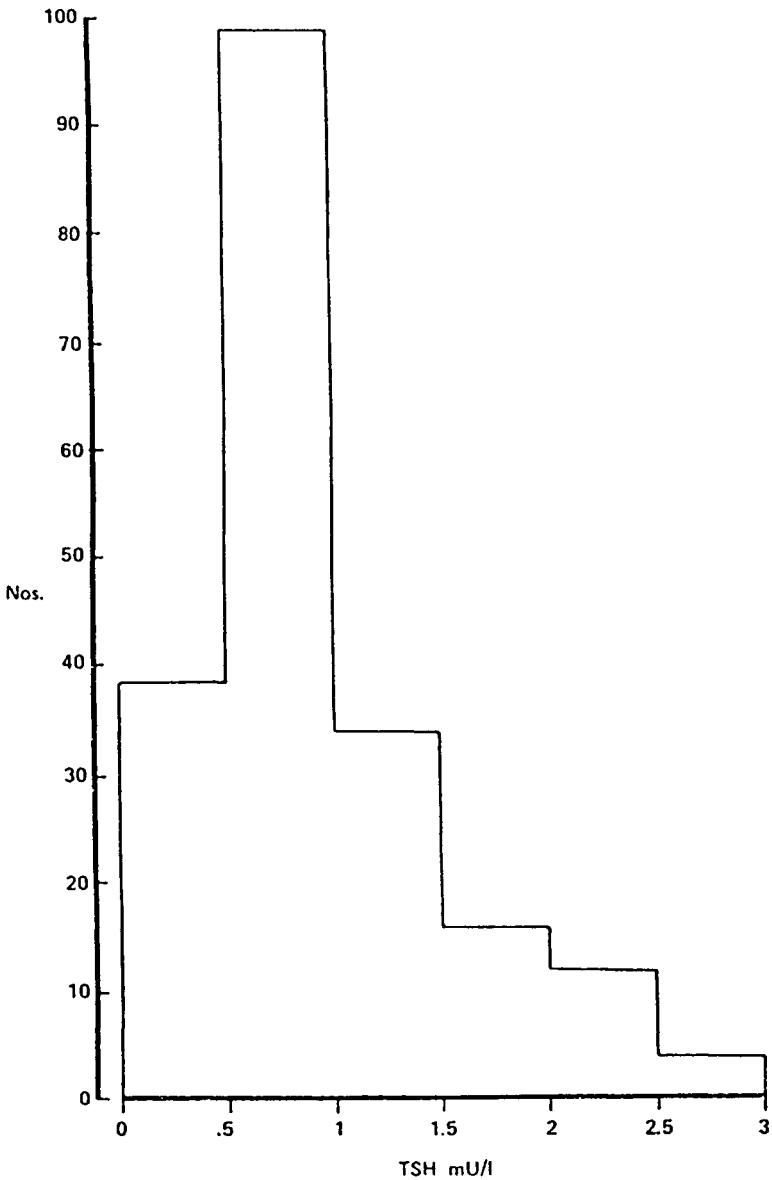

Figure 4. A calculated frequency distribution of TSH according to the observed distribution of T4 in 168 healthy adults. The calculation permits TSH levels less than 0.5 mU/L.

The Relationship between TSH and Thyroid Function

The rise in TSH which accompanies the fall in T4 in patients with primary hypothyroidism is perhaps the best known characteristic of a feedback control loop. The rise is frequently referred to as “compensatory,” but the true mechanism is more profound, and the result far from compensatory.

The loss of thyroid gain resulting from thyroid damage reduces overall loop gain. The quality of loop control diminishes and a new equilibrium is established which tolerates a higher error. The pituitary gland, which is undamaged, responds with an increase in TSH. It was established earlier that the performance of the loop in controlling T4 was dependent wholly on loop gain. The rise in TSH is a reflection of the fall in loop gain and in no sense compensates for it.

Figure 5 indicates that the relationship between T4 and TSH with falling thyroid efficiency is far from linear. By the nature of log–linear based control loop responses, the fall in T4 is minimal, even at a 50% reduction in thyroid efficiency, while the TSH has risen well outside its normal range. This is because, in log–linear systems, the smallest changes in input are associated with the (proportionately) largest changes in output.

A further point of clinical importance emerges here. It is clear that two factors (omitting for the moment pituitary function) influence TSH—the level of hypothalamic demand and the efficiency of the thyroid. Both factors of course operate through their influence on loop gain (TSH is a function of the error which is solely dependent on loop gain), and each influences TSH in the opposite direction with respect to their effect on the T4 level, i.e. TSH falls with T4 if the TRH level falls, but rises when the fall in T4 is due to thyroid damage. To separate these two factors it is necessary to construct two sets of graphs, each defining the change in TSH with declining thyroid function at a different level of TRH demand.

The Relationship between TSH and Thyroid Function at Different Levels of TRH

Figure 6 expresses the relationship between TSH and T4 calculated for 10 different levels of TRH demand designed to cover the range of T4 in a healthy population in steps of 10 nm/L from 70 to 140 nmol/L. At each setting of TRH, the TSH level was calculated for thyroid efficiencies (g_2) varying from 100% (health) to 20% (severe damage). The result is a family of constant TRH curves each defining the relationship between TSH and thyroid efficiency at a different TRH setting. These curves are linear and parallel, as was observed empirically in the rats subjected to progressive hypothalamic damage (Reichlin et al., 1972) on a log–linear plot. Their gradient is equal to pituitary gain.

The point of importance to biochemical interpretation is the realization that the TSH level may vary considerably for the same level of T4 depending on which particular TRH setting the individual lies; thus, the finding of a T4 level of 100

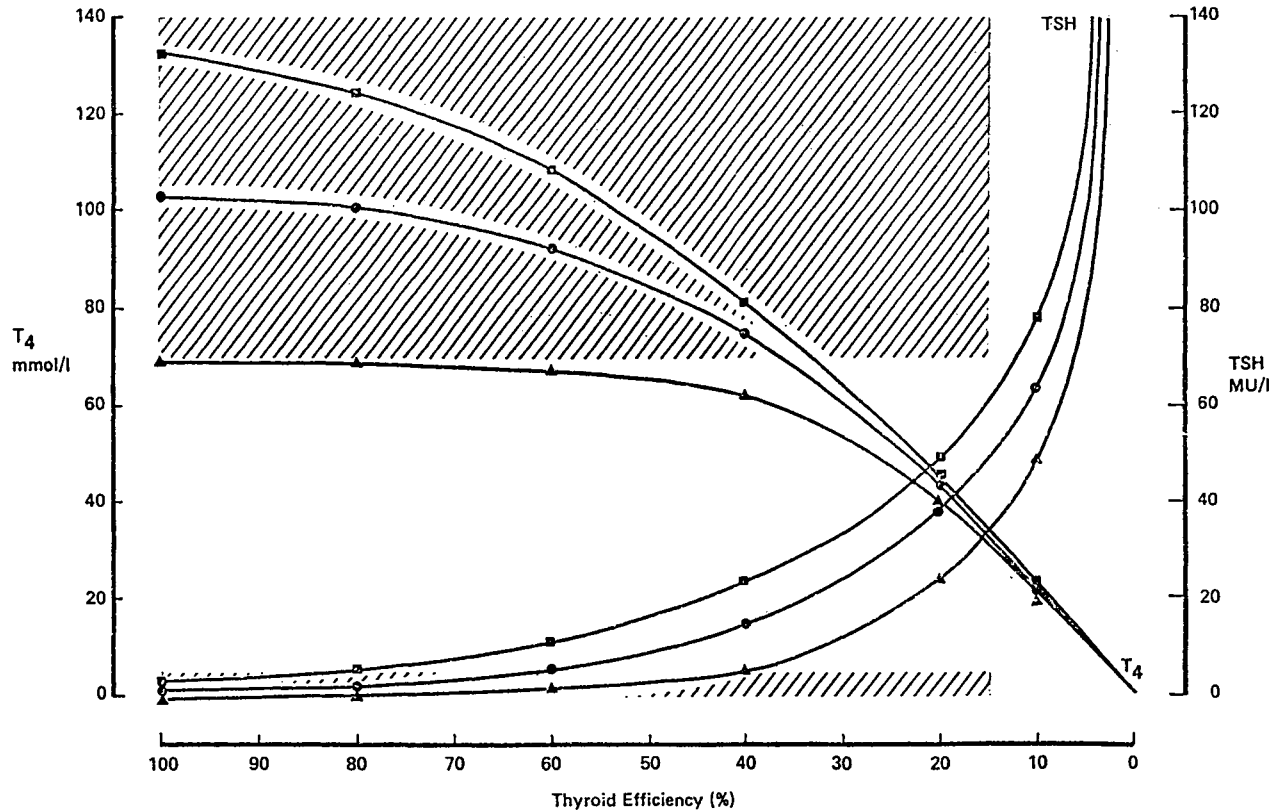

Figure 5. Calculated responses of TSH and T4 to falling thyroid efficiency at three different levels of TRH setting (\blacktriangle demand is 70 nmol/L T4, \bullet 105 nmol/L T4, \blacksquare 40 nmol/L T4).

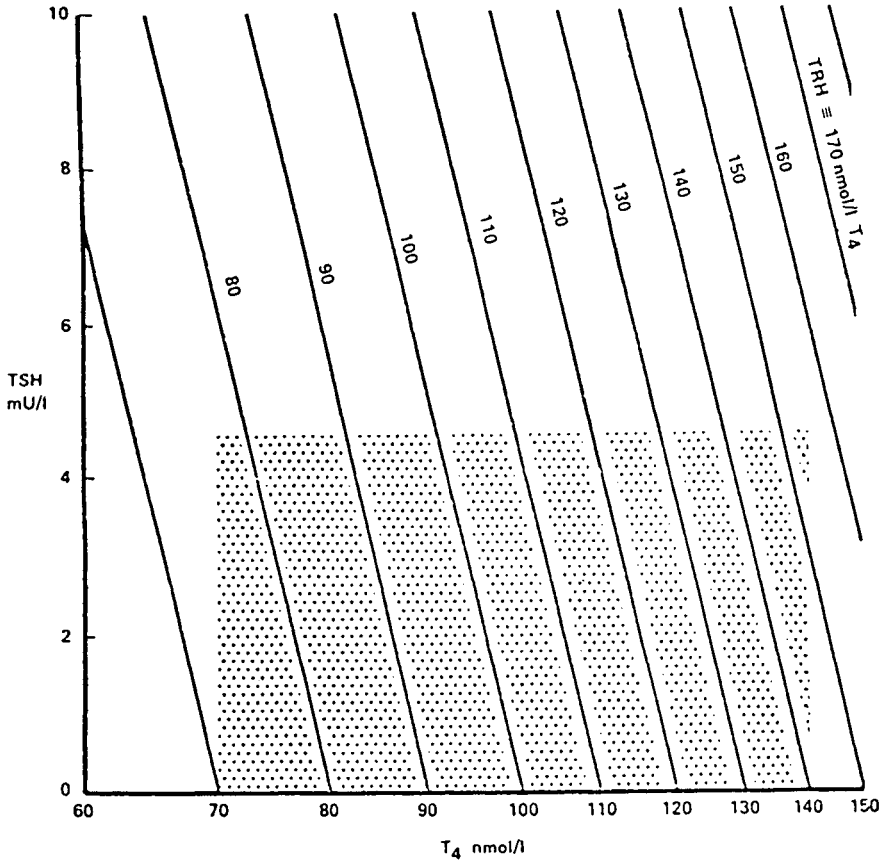

Figure 6. A family of constant TRH curves obtained by calculation. Their points of intersection with the abscissa represent perfect control ($T_4 = TRH$, 0 error, $TSH = 0$). Positions further up the curves represent falling thyroid efficiency at constant level of TRH demand. The gradient of the curves (pituitary gain) determines the degree of departure of T_4 from optimum for any given reduction in thyroid gain, and the corresponding TSH level. The hatched area defines the reference ranges.

nmol/L is consistent with a normal TSH level in the person whose TRH demands little more than 100 nmol/L of T_4 , but with an elevated TSH in the individual whose optimal T_4 (i.e. TRH setting) is 130 nmol/L. For this reason, TSH is undoubtedly a better index of suboptimal thyroid function than is T_4 , simply because (given healthy pituitary function) it reflects error in the system. Furthermore, the presentation of data in this way underlines the limitations of the concept of a “normal” range for biochemical variables. An individual whose optimal T_4 is 130 nmol/L would be seriously deficient in thyroid hormone if it fell to 80 nm/L, yet the T_4 level remains officially normal (i.e. within the range 70–140 nm/L). Conversely,

the individual with a T4 level of 60 nmol/L would be much less seriously deficient if his optimum T4 were 80 nmol/L, but he is nevertheless more likely to be considered hypothyroid than the first example.

The Interaction between Pituitary and Thyroid in Producing Control

The performance of the pituitary and thyroid can be analyzed independently by breaking or “opening” the loop and graphing the dose–response curves of each

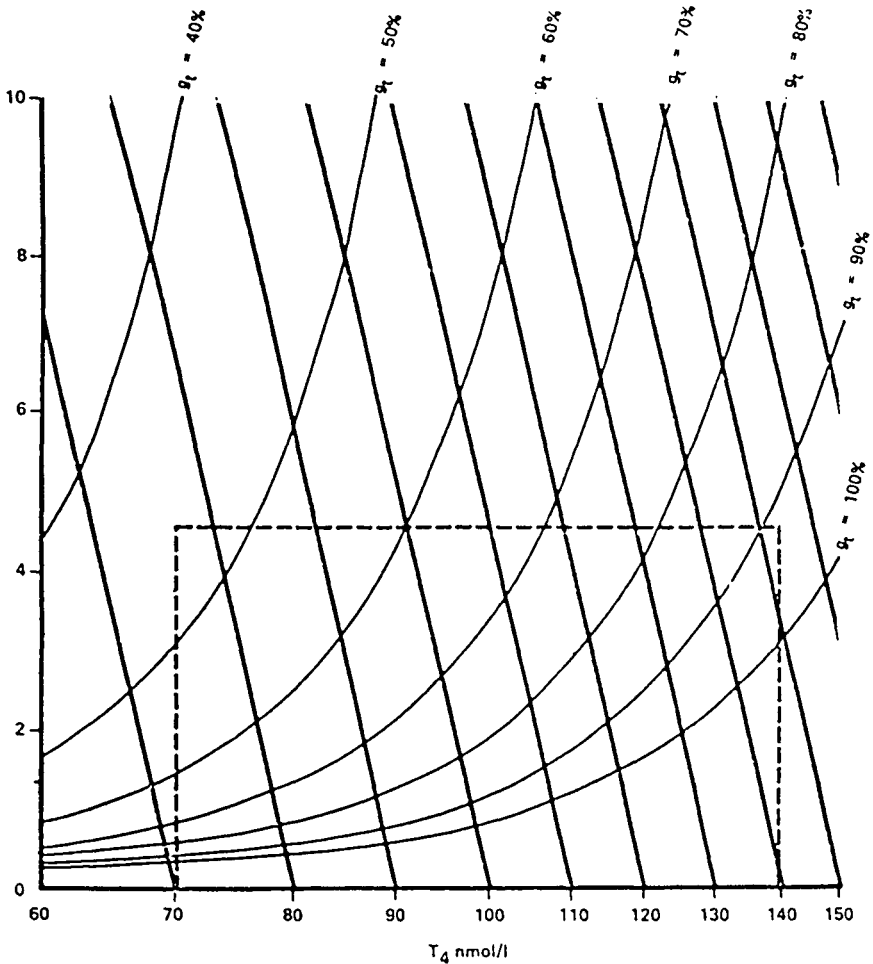

Figure 7. The plot in Figure 6 has been superimposed with a family of constant thyroid gain curves. The intersections between the lines of constant TRH and curves of constant thyroid gain represent the equilibrium between TSH and T4 for a given thyroid gain at any particular level of TRH demand.

component at different settings. Thus, pituitary performance is demonstrated by varying the error (i.e. lowering the T4 level stepwise against a constant TRH input) and measuring TSH, and thyroid performance by varying TSH and measuring the resulting levels of T4. The gradients of the curves are obtained to find a gain at each level of efficiency. The simultaneous responses in both organs (i.e. their interaction within the closed loop) may be visualized by superimposing the two sets of graphs (Figure 7). The result is merely a representation of the points of intersection between the dose–response curves of each component at different levels of input and at different levels of efficiency. The points of intersection represent the equilibrium to which the loop will settle under a particular set of circumstances—and in reality provide answers to the simultaneous equations established earlier.

The plot in Figure 7 emphasizes many key aspects of loop behavior. First, by following a line of constant thyroid efficiency, for instance 70% ($g_t = 70\%$), it becomes clear how the TSH rises exponentially with increasing levels of TRH demand. In short, loading the loop reduces its gain and thereby the quality of control it can achieve. Accordingly, a patient with 70% nominal thyroid efficiency, whose hypothalamus sets a T4 level of 130 nmol/L, in practice achieves only 112 nmol/L, whereas a similar patient demanding a T4 level of only 80 nmol/L very nearly achieves it at 78 nmol/L. The difference in TSH levels between the two patients is considerable (8.0 and 1.2 $\mu\text{U/L}$, respectively) and yet their thyroid function (efficiency) is the same. Thus the influence on loop gain of a particular fall in thyroid performance (in this case to 70%) depends largely on the level of hypothalamic demand.

The fact that loop gain in a log–linear control loop is influenced independently by its set point and by its generator efficiency also predicts, perhaps contrary to expectation, that normal people with T4 levels to the lower end of the normal range have TSH levels no different from those whose T4 levels lie towards the upper limit of the normal range. In clinical practice, there is no systematic relationship between T4 and TSH, as confirmed in Figure 8.

When the calculated relationships are superimposed on the clinical observations (Figure 9), the presentation of data helps to take the interpretation of TSH and T4 levels one stage further. Two individuals, both female, have been identified as A and B in Figure 9. Both have the same TSH level, but very different T4 levels. It has been suggested in the past that TSH is the most sensitive measure of thyroid failure (Evered et al., 1973). In this particular example, however, while patient A may arguably be heading for thyroid failure, patient B clearly is not with a thyroid gland efficiency (g_t) of over 80%. Control theory dictates that TSH values reflect loop gain, not the thyroid gain constant. Patient A with a thyroid efficiency of 42% is able to maintain the same loop gain (i.e. TSH level) as patient B only because her TRH setting (ca. 73 nmol/L) is considerably lower than that of patient B (ca. 134 nmol/L) and her control loop correspondingly less stressed. Thus, both patients exercise the same quality of control over their T4 level despite very different thyroid efficiencies. Patient A obtains 66 nmol/L T4 out of an optimal 73 nmol/L

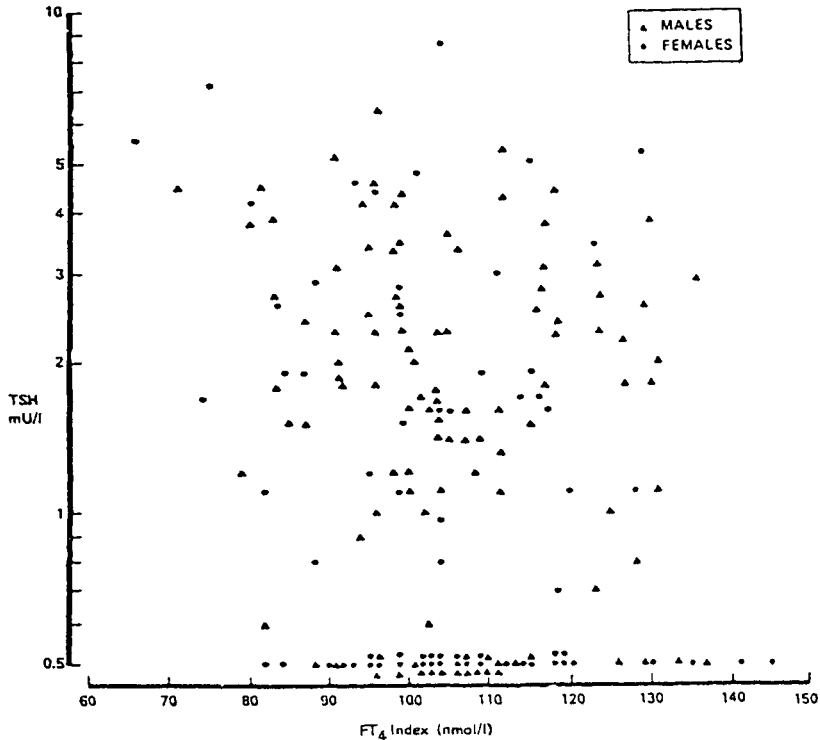

Figure 8. The observed relationship between TSH and FT4 index in 188 normal adults (67 women and 121 men).

(90%) and Patient B 130 nmol/L out of 144 nmol/L (90%). Despite the comparable degree of control over T4 that each individual is able to offer, A appears (at 42% nominal thyroid efficiency) to exert considerably less than B.

The entire line of reasoning in the foregoing paragraphs calls into question the validity of a fixed upper limit of serum TSH to indicate normal thyroid performance over a wide range of T4. The TSH undoubtedly reflects loop performance, but loop gain is not determined by thyroid efficiency alone. Figure 9 suggests that the TSH level corresponding to a thyroid gain constant of 90% could vary from 0.5 to 5 mU/L depending on the hypothalamic set point. The clinical use of a fixed upper limit for TSH will not, it appears, permit the early detection of failing thyroid function, although it will accurately reflect failing loop function. According to the clinical data in Figure 8, the TSH level in 90 to 95% of a healthy population lies below 4.5 mU/L. If this limit is taken as a universal criterion of normality, Figure 9 would suggest that a 50% drop in thyroid function (i.e. from 100% efficiency to 50% efficiency in an individual with a TRH set point of 80 nmol/L) could go unnoticed.

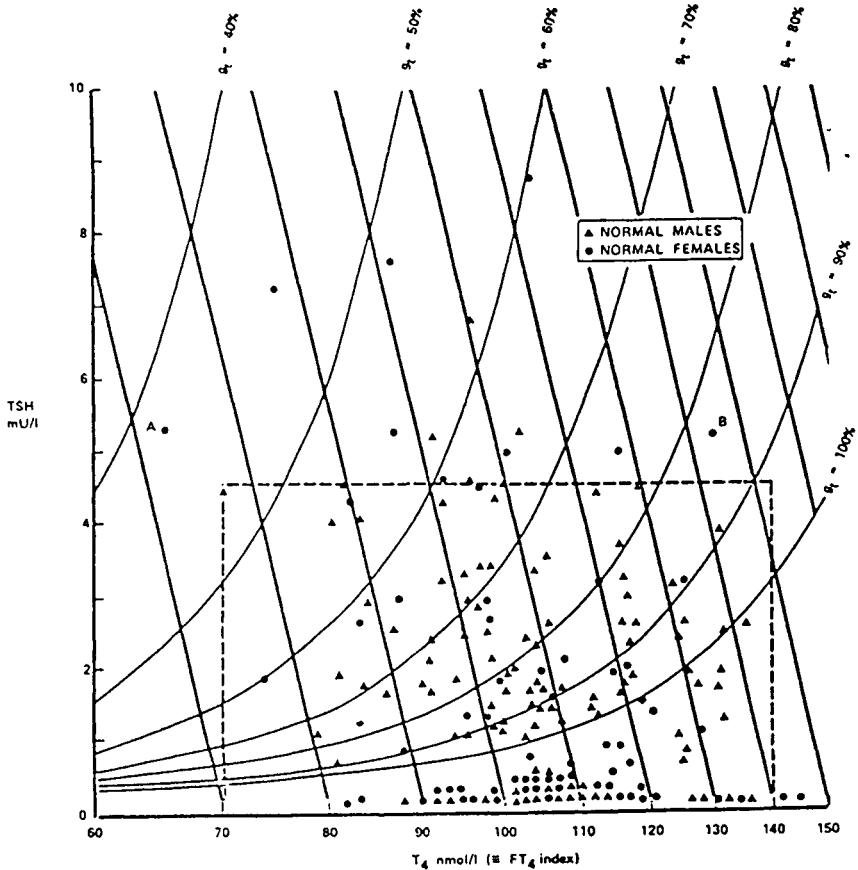

Figure 9. Clinical data from 188 normal individuals superimposed on the calculated relationship between variations of TRH and thyroid efficiency. The boxed area defines reference ranges. The clinical data were measured as FT4 index and the calculated data expressed as T4. g_t = thyroid gain constant (efficiency). Pituitary function was assumed constant.

The Clinical Interpretation of Trophin Levels

A raised TSH level among clinically euthyroid individuals (Hedley et al., 1971; Evered et al., 1975) whose T4 level lies within the reference range has been widely reported after thyroid surgery, symptomless thyroiditis (Gordin et al., 1974) and after radioiodine treatment (Toft et al., 1973; Tunbridge et al., 1974) for hyperthyroidism (Figure 10). The term “subclinical hypothyroidism” was applied to this group of patients many years ago (Evered et al., 1973) and appears appropriate in as far as the raised TSH reflects suboptimal loop control for thyroid hormone levels.

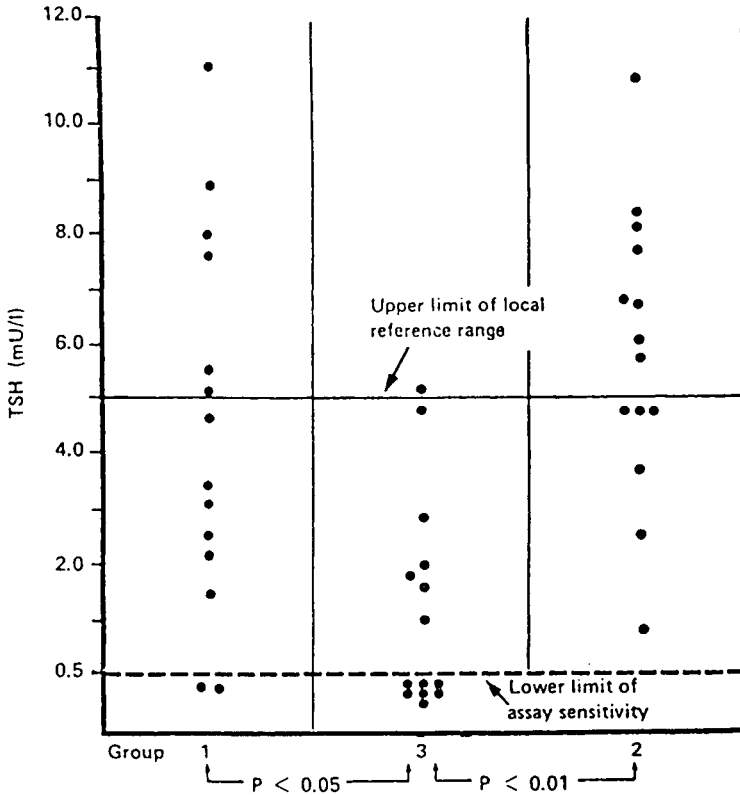

Figure 10. Individual TSH concentrations in three groups of patients with identical FT4 indices. Group 1: toxic patients 18 months after thyroidectomy; Group 2: lithium carbonate-treated patients; Group 3: healthy controls.

The term does not imply, however, that the patient is or will become clinically hypothyroid.

It is clear from Figure 5 that the trophic levels of endocrine feedback loops (in the example TSH) rise exponentially with the error. This, of course, is a function of the log-linear relationships within the loop. It does mean, however, that the biological significance of a rise in TSH from 1 to 5 mU/L is the same as a rise from 10 to 50 mU/L. The same applies to all trophins, and it is particularly important to keep in mind the biological significance of changes in serum prolactin which may rise to 600 or 700 mU/L in normal individuals. Here, a change from 100 to 1000 mU/L has the same biological implication as a change from 1000 to 10,000 mU/L, or 10,000 to 100,000 mU/L. In this connection, it is one of the conundrums of endocrinology that the distribution of serum prolactin behaves as if the hormone were a trophic like TSH or ACTH, rather than an end hormone like thyroxine or

cortisol. As yet, no prolactin-controlled hormone has been identified in the circulation. It should be recalled that growth hormone was thought to be an end hormone before the discovery of the insulin-like growth factors (termed somatomedins at the time) many years ago (Daughaday et al., 1972). The term growth hormone is a misnomer, as GH is a trophin (somatotrophin) and, like all endocrine trophins, has a skewed distribution. The somatomedins, predictably, have a Gaussian distribution.

The Endocrine Index

Reference was made earlier to the gain constant of the thyroid as the parameter which determines the output of the gland (T4) for any given input (log TSH). The gain constant defines the slope of the relationship between log TSH and T4, and will be expected to vary with the functioning mass of thyroid tissue. Although the TSH level is widely regarded as the best index of thyroid function, it reflects not the gain constant of the thyroid, but its gain factor which is influenced by variations in hypothalamic set point and pituitary function. The singular importance of the gain constant is that it defines the performance of the thyroid independently of these other variables: it is a true parameter of thyroid function. The same applies to the ACTH/cortisol, LH-FSH/sex steroid, STH/IGF, insulin/glucose, PTH/calcium, and other systems.

TSH is normally the only stimulus to thyroid hormone release, and the majority of hormone produced by the thyroid is in the form of T4. The “thyroid index” referred to here is derived from the ratio $T4/\log TSH \times 100$ and should in theory be a constant reflecting the functional mass of thyroid tissue irrespective of stimulation (between the limits of sensitivity threshold to TSH and saturation point).

It may be predicted that two factors will produce an artificially high thyroid index. The administration of thyroxine will cause a rise in circulating T4 and depression of TSH without changing the thyroid’s gain constant. Similarly, extra-pituitary stimulation of the thyroid by TSH receptor stimulating antibodies will raise the circulating T4 concentration and lower the TSH level. In the latter circumstance, there may also be an increase in the functional mass of thyroid tissue due to hyperplasia, but this would not be necessary to cause the apparent increase in thyroid index. A fall in thyroid index, in the absence of extra-pituitary stimulation, should indicate a proportionate loss of functioning thyroid mass, while the simultaneous rise in TSH would indicate the loss of loop gain. The distinction is not altogether academic because, as indicated previously, gain factor and gain constant are not synonymous in a biological (log–linear) loop.

Figure 11 shows the thyroid index calculated for different clinical groups and compared with the normal range for males and females. Lithium has an anti-thyroid action, and predictably the thyroid index is lower in patients treated with lithium. The thyroid index after surgical treatment of nontoxic goiter was, in the series shown, significantly lower than the index after surgery for Graves’ hyperthyroidism.

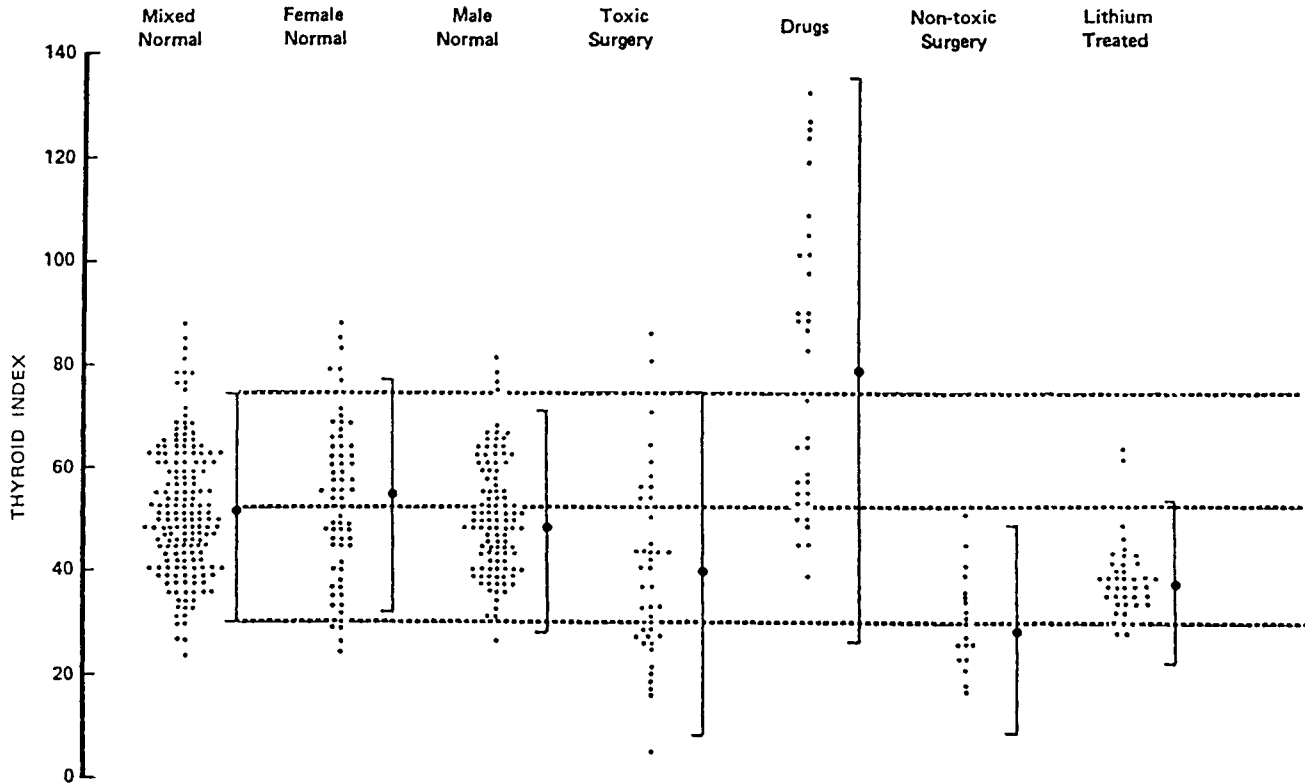

Figure 11. The thyroid index (FT4 index/log TSH × 100) in normal individuals and after thyroid treatment. "Toxic surgery"-identifies surgically treated hyperthyroid patients, "drugs"-drug treated hyperthyroid patients, "nontoxic surgery"- euthyroid patients treated surgically, and "lithium-treated"-euthyroid patients treated with lithium carbonate.

There are two possible clinical interpretations. Either the mass of functioning thyroid tissue remaining after surgery for Graves' hyperthyroidism was larger, or TSH receptor stimulating antibodies remained after surgery in this group and gave rise to an artefactually high thyroid index. The high thyroid index in Graves' patients treated with anti-thyroid drugs can almost certainly be explained on the same basis, since the serum thyroid hormone levels had fallen to normal in this group at the time of testing.

The Implications of Hormone Replacement for Hormone Control

It will be appreciated that an endocrine gland may fail by degrees. As is clear from Figure 5, early loss of transfer factor (in this case the thyroid's) results in a curvilinear fall in output level as the trophin level rises exponentially. A point is reached, however, when the slope becomes linear, indicating that saturation has been reached and that the transfer factor or gain has fallen to zero. Zero gain for the thyroid means zero gain for the entire loop and, inevitably, total loss of output control. The administration of hormone replacement cannot reestablish control—it can only provide a level of hormone determined by the dose given. Clinically, the implications of this state may be minor or critical. The serum levels of thyroxine do not vary from day to day or even week to week in health, so that the regular administration of a long half-life medication such as thyroxine is readily adjusted according to the TSH level. Serum cortisol, on the other hand, fluctuates in a circadian rhythm determined by a constantly varying set point. Failure of the pituitary–adrenal control loop makes replacement therapy difficult and frequent cortisol day curves may be necessary to ensure that the excursions of serum cortisol are close to physiological.

The question arises as to the effect of replacing a hormone where loop gain is reduced, but the system is not yet saturated and still retains a degree of control. Clearly, replacing hormone where loop gain is diminished will raise the circulating hormone level, but will replacement therapy strengthen or weaken the quality of control? On first principles it may be argued that “shutting down” the loop with exogenous hormone through negative feedback will weaken homeostasis, but in practice the reverse is true. Figure 12 calculates the effects of giving increasing doses of thyroid hormone, sufficient to provide serum concentrations of 20, 50, and 100 nmol/L to an individual whose thyroid transfer factor has fallen to 60%. It is clear that, provided the serum concentration of the T4 administered does not exceed the lower limit of the range to be controlled, the quality of control over that range is improved, to an extent which increases with the dose given. The range of improved control, however, does not extend below the serum concentration of T4 provided by the administered dose. Thus, the ideal level of replacement therapy in hypothyroidism would appear to be a dose equivalent to a serum concentration towards the lower limit rather than towards the upper limit of the normal reference range.

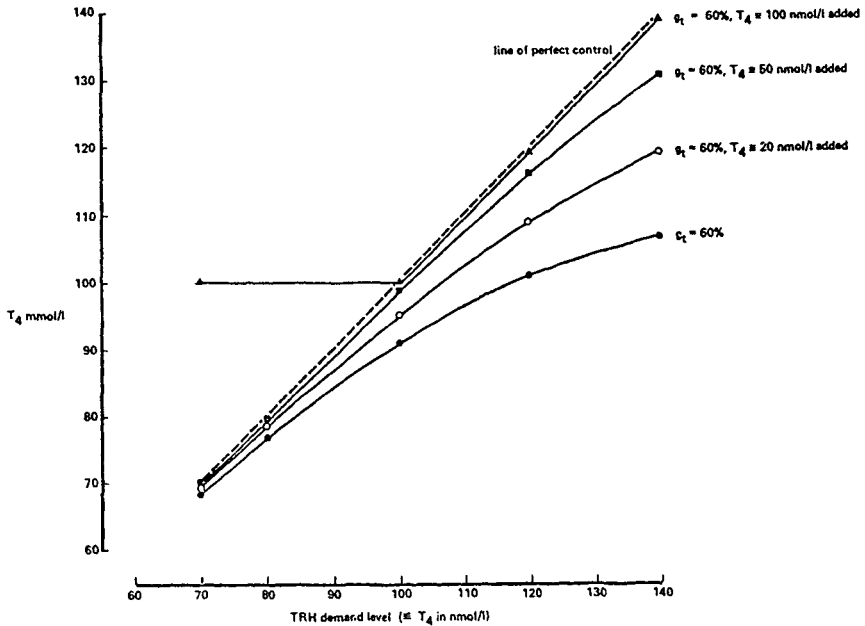

Figure 12. The effect on T4 control, over a range of TRH demand, of replacement treatment with incremental doses of thyroxine in a patient with a nominal thyroid gain of 60%. Note that, predictably, a dose of thyroxine sufficient on its own to raise the serum thyroxine concentration above 100 nmol/L causes loss of control at levels of TRH demand less than T4 100 nmol/L. At the same time, this dose of thyroxine produces excellent control of serum T4 at levels of TRH demand above T4 100 nmol/L.

The simulated individual in Figure 12 with a thyroid efficiency of 60% whose hypothalamic set point demands 130 nm/L T4 achieves only 105 nm/L. If the first 70 of the desired 130 nm/L are provided by exogenous T4, his control loop is left with making up the remaining 60 nm/L. This it is able to do almost completely by virtue of the unique characteristics of log-linear control. It was explained earlier how the gain of a biological (log-linear) loop rises with declining input. In the clinical situation under consideration, partial replacement with T4 reduces the error in the loop and the consequent rise in loop gain provides improvement in control. Again, it must be emphasized that the improvement is not just in the circulating levels of T4, but in the capacity of the loop to control them. Careful dosimetry of replacing therapy clearly has clinical implications.

Positive Feedback

Negative feedback control is ubiquitous in endocrine systems, but there is one very clear example where positive feedback temporarily supervenes. The sex

steroid fluctuations during the menstrual cycle are brought about by rhythmic fluctuations in the hypothalamic set point. Thus the estrogen level climbs during the first (follicular) part of the cycle as the hypothalamic set point for estrogen dictates. The concurrent rise in LH reflects the progressive loss of loop gain as an increasing load placed by GnRH on the loop. However, at a particular threshold the serum estrogen, rather than feeding back negatively on pituitary LH release, suddenly stimulates its release in the form of the pre-ovulatory LH surge. Failure of this surge to occur leads to failure of ovulation.

Positive feedback of this kind must not be confused with the feedback relationships for the control of blood glucose. Here, the insulin level rises as the blood glucose rises, but the function of the loop is nevertheless to constrain and this it achieves by the glucose lowering, rather than stimulating action of insulin. Positive feedback during the LH surge represents a temporary and acute escape from constraint.

CONCLUSIONS

Negative feedback control is an engineering principle applied as much by science as by Nature. Nature, however, has incorporated a particularly elegant modification in the form of log-linear transfer functions which confer very special properties upon biological loops. The most important, perhaps, is that a small error exerts a disproportionately high input, thereby permitting precise control where small adjustments in set point demand small changes in output. Understanding the mechanisms of feedback control provides a rational basis for investigation, interpretation, and management of endocrine dysfunction.

REFERENCES

- Allen, B.M. (1916). The results of extirpation of the anterior lobe of the hypophysis and of the thyroid of *Rana pipiens* larvae. *Science* 44, 755-.
- Aron, M. (1929). Action de la pre-hypophyse sur la thyroïde chez le cobaye. *Compt. Rend. Soc. Biol.* 102, 682.
- Aron, M., Van Coulaert, C., & Stahl, J. (1931). L'équilibre entre l'hormone hypophysaire et l'hormone thyroïdienne dans le milieu intérieur à l'état normal l'état pathologique. *Compt. Rend. Soc. Biol.* 107, 64.
- Bogdanove, E.M. (1962). Regulation of TSH secretion. *Fed. Proc.* 21, 623.
- Daughaday, W.H., Hall, K., & Rayben, M.S. (1972). Somatomedin: proposed designation for sulfation factor. *Nature* 235, 107.
- Di Stefano, J.J., & Stear, E.B. (1968). Neuroendocrine control of thyroid secretion in living systems. A feedback control system model. *B.M. Bull. Math. Biophys.* 30, 1.
- Evered, D., Young, E.T., Tunbridge, W.M.G., Ormston, B.J., Green, E., Peterson, V.B., & Dickinson, P.H. (1975). Thyroid function after sub-total thyroidectomy for hyperthyroidism. *Brit. Med. J.* 1, 25.
- Evered, D.C., Ormston, B.J., Smith, P.A., Hall, R., & Bird, T. (1973). Grades of hypothyroidism. *Brit. Med. J.* 1, 657.

- Gordin, A., Saarinen, P., Pelkonen, R., & Lamberg, B-A. (1974). Serum TSH and the response to TRH in symptomless autoimmune thyroiditis and in borderline and overt hypothyroidism. *Acta Endocrinol.* 75, 274.
- Greer, M.A. (1951). Evidence of hypothalamic control of the pituitary release of TSH. *Proc. Soc. Exp. Biol.* 77, 603.
- Harris, G.W. (1948). Neural control of the pituitary gland. *Physiol. Rev.* 28, 139.
- Harris, G.W. (1955). The function of the pituitary stalk. *Johns Hopkins Hosp. Bull.* 97, 358.
- Hazen, H.L. (1934). Theory of servo-mechanisms. *J. Franklin Inst.* 218, 279.
- Hedley, A.J., Hall, R., Amos, J., & Michie, W. (1971). Serum thyrotrophin levels after sub-total thyroidectomy for Grave's Disease. *Lancet* 1, 455.
- Hersmann, J.M., & Pittman, J.A. Jr. (1971). Control of TSH secretion in man. *N. Engl. J. Med.* 285, 997.
- Hoskins, R.G. (1949). The thyroid pituitary apparatus as a servo (feedback) mechanism. *J. Clin. Endocrinol. Metab.* 9, 1429.
- James, H.M., Nicholls, N.V., & Phillips, R.S. (1947). *Theory of Servo-Mechanisms*. McGraw Hill, New York.
- Kuschinsky, G. (1933). Quoted by Reichlin, S. (1966). Control of thyrotropic hormone secretions. In: *Neuroendocrinology* (Martini, L., & Ganong, W.F., Eds.) Vol. 1; p. 445. Academic Press, New York.
- Loeb, L., & Vasset, R.B. (1929). Effect of hormone of anterior pituitary on thyroid gland in the guinea pig. *Proc. Soc. Exp. Biol. Med.* 27, 490.
- Niepcz, P. (1851). Quoted by D'Angelo, S.A. (1955). Pituitary regulation of thyroid gland function. *Brookhaven Symp. Biol.* 7, 9.
- Purves, H.D. (1964). The control of thyroid function. In: *The Thyroid Gland* (Pitt-Rivers, R., & Trotter, W.R., Eds.), pp. 1 et seq. Butterworths, London.
- Phillips, J.N. (1947). *Theory of Servo-Mechanisms*. McGraw-Hill, New York.
- Reichlin, S., Martin, J.B., Mitnick, M.A., Boshans, R.L., Grim, Y., Bollinger, J., Gordon, J., & Malacara, J. (1972). The hypothalamus in pituitary thyroid regulation. *Rec. Prog. Horm. Res.* 28, 229.
- Salter, W.T. (1940). *The Endocrine Function of Iodine*, pp. 131 et seq. Harvard University Press, Cambridge, MA.
- Shibusawa, K., Saito, S., Nishi, K., Yamamoto, T., Tomizawa, K., & Abe, C. (1956). The hypothalamic control of thyrotroph-thyroidal function. *E. J. Endocrinol. Japan* 3, 116.
- Smith, P.E. (1916). The effect of hypophysectomy in the early embryo upon the growth and development of the frog. *Anat. Rec.* 11, 57.
- Smith, P.E., & Smith, I.P. (1922). The repair and activation of the thyroid in the hypophysectomized tadpole by the parenteral administration of fresh anterior lobe of bovine hypophysis. *J. Med. Res.* 43, 267.
- Toft, A.D., Hunter, W.M., Barnes, E.W., Seth, J., & Irvin, W.J. (1973). Raised plasma TSH levels in thyrotoxic patients treated with iodine-131. *Lancet* 2, 644.
- Tunbridge, W.M.G., Harsoulis, P., & Goolden, A.W.G. (1974). Thyroid function in patients treated with radioactive iodine for thyrotoxicosis. *Brit. Med. J.* 3, 89.
- Utiger, R.D., & Reichlin, S. (1966). The relationship of plasma TSH to plasma free thyroxine concentration. *Clin. Res.* 14, 289.
- Vale, W., Burgus, R., & Guillemin, R. (1967). Competition between thyroxine and TRF at the pituitary level in the release of TSH. *Proc. Roy. Soc. Exp. Biol. Med.* 125, 210.

Chapter 2

Mechanisms of Negative and Positive Feedback of Steroids in the Hypothalamic–Pituitary System

GEORGE FINK

Introduction	30
Negative Feedback in the Hypothalamic–Pituitary–Adrenal Axis	35
Introduction	35
Principles of Negative Feedback Illustrated by the HPA System	37
Clinical Manifestations of Disordered Glucocorticoid Feedback Regulation	48
Summary	52
Negative Feedback in the Hypothalamic–Pituitary–Gonadal Axis	53
Introduction	53
Summary	56
Steroid Positive Feedback: Spontaneous Gonadotropin and Prolactin Surges	57
General Overview of the Mechanism of the Spontaneous Gonadotropin Surge	57
Generation of the LHRH Surge	60
Changes in Pituitary Responsiveness to LH-Releasing Hormone	67
The Apparent Paradox of Negative–Positive Feedback of Estradiol-17 β and Progesterone	76

Principles of Medical Biology, Volume 10A
Molecular and Cellular Endocrinology, pages 29–100.
Copyright © 1997 by JAI Press Inc.
All rights of reproduction in any form reserved.
ISBN: 1-55938-815-3

The Prolactin Surge	77
Proof for a Daily Neural Signal for LH and Prolactin Release	78
Hypothetical CNS Model for the Positive Feedback	
Release of LH and Prolactin	79
Summary	81
Clinical Significance of Estrogen Feedback and the LHRH Self-Priming Effect	82
Overall Conclusions and Hypotheses	84

INTRODUCTION

Feedback control systems are fundamental for physiological mechanisms. Disruption of feedback control almost inevitably leads to a pathological state. The consequence of a failure in negative feedback is exemplified by the adrenogenital syndrome. Failure in positive feedback is exemplified by disruption of the estrogen positive feedback on the hypothalamic-pituitary system which results in failure of the ovulatory surge of luteinizing hormone (LH) and consequent female infertility.

Crucial for homeostasis, negative feedback control mechanisms are comprised of a system in which the output moderates the strength of the controller to a predetermined set-point level (Figure 1) (Milhorn, 1966). The set-point-stimulator complex contains a "comparator" (error detector) which compares the strength of the feedback signal with a preset level (Figure 1). An increase in the strength of the feedback signal above the preset level reduces the output of the stimulator; a decrease in strength of the feedback signal below the preset level results in an increase in output of the stimulator (Figure 2A). That is, the comparator determines the actual and the preset level of the feedback signal and corrects the "error". Negative feedback control operates widely throughout the body at the molecular (e.g. end-product inhibition of enzyme activity), cellular, and whole systems/body level.

Positive feedback, whereby the output of a system increases the output of the stimulator (gain in the system) (Figures 1 and 2B), is far less common than negative feedback, possibly because taken to its logical conclusion a positive feedback system will eventually self-destruct. Some systems loosely termed "positive feedback," are in fact "servomechanisms." A servomechanism is a closed loop control system which transforms a small input of power into a significantly larger output of power. There are many negative feedback and several servomechanisms in the body, but here attention will focus on the role of steroids in negative feedback, positive feedback, and servomechanisms in the control of the hypothalamic-pituitary-adrenal and gonadal axes (HPA and HPG, respectively).

Removal of the target glands, the adrenal or the gonads, the most reproducible and reproduced experiment in classical endocrinology, demonstrates that the basal secretion of adrenocorticotropin (ACTH) and the gonadotropins (luteinizing hor-

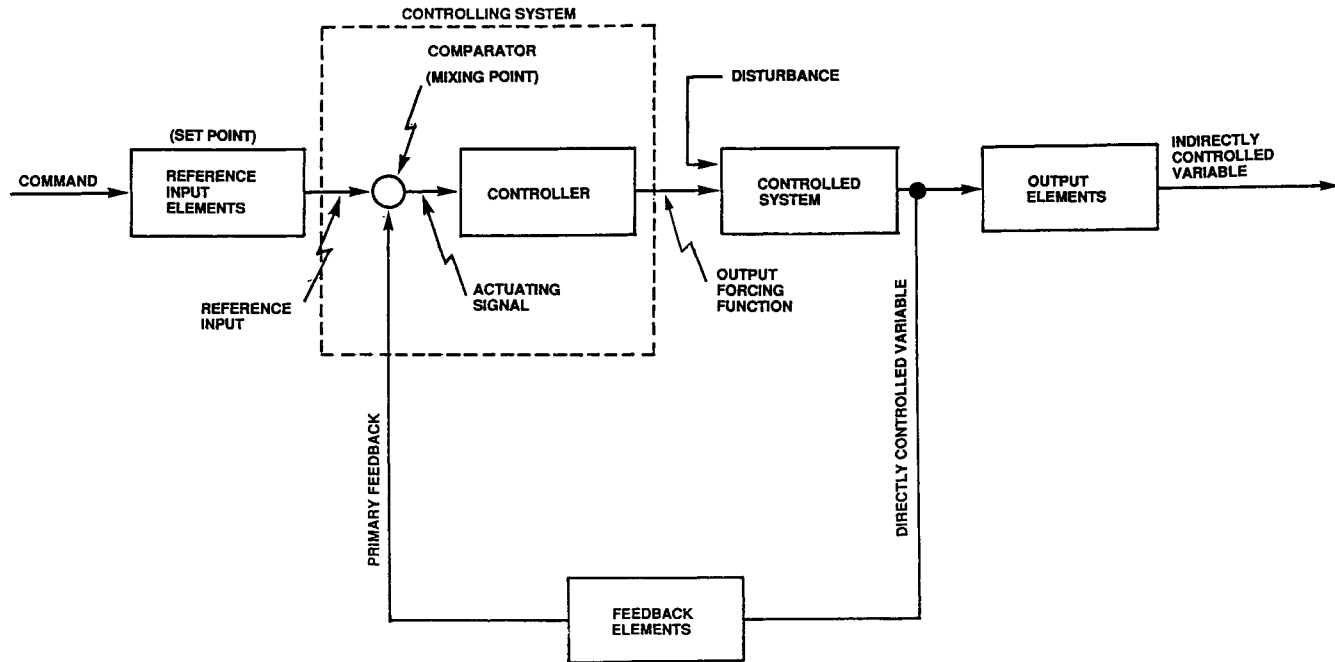
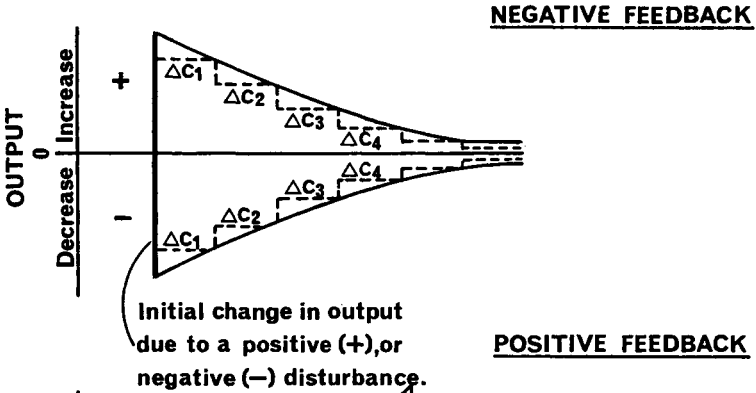

Figure 1. A generalized feedback control system. [Slightly modified from Milhorn (1966) with permission from W.B. Saunders Company, Philadelphia].

A



B

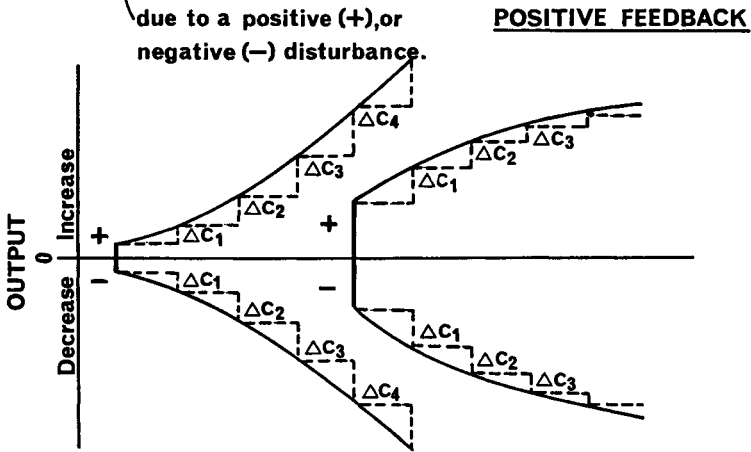

Figure 2. (A) Negative feedback minimizes the disturbance to a regulator resulting in a system in which the output tends to remain constant. In this case, the ratios of the decrements of the controlled variable (ΔC) ($\Delta C_2/\Delta C_1$, $\Delta C_3/\Delta C_2$) are less than unity. (B) In positive feedback (left-hand curves) an initial disturbance results in a continuous increase in output ("vicious cycle"). The increments of the controlled variable ($\Delta C_2/\Delta C_1$, $\Delta C_3/\Delta C_2$) are greater than unity. When the response does not result in a vicious cycle, the ratios of $\Delta C_2/\Delta C_1$, $\Delta C_3/\Delta C_2$, etc. are less than unity in (see right hand curves in B). [From Milhorn (1966) with permission].

none, LH, and follicle stimulating hormone, FSH) is controlled by powerful negative feedback exerted by the adrenal corticosteroids and gonadal steroids, respectively. A break in the negative feedback loop caused, for example, by surgical or pharmacological adrenalectomy or gonadectomy or an enzymic defect in steroid synthesis, results in massive hypersecretion of ACTH or LH and FSH.

In the normal state, with negative feedback loop intact, the set-point in the brain-pituitary module maintains the secretion of ACTH and the gonadotropins

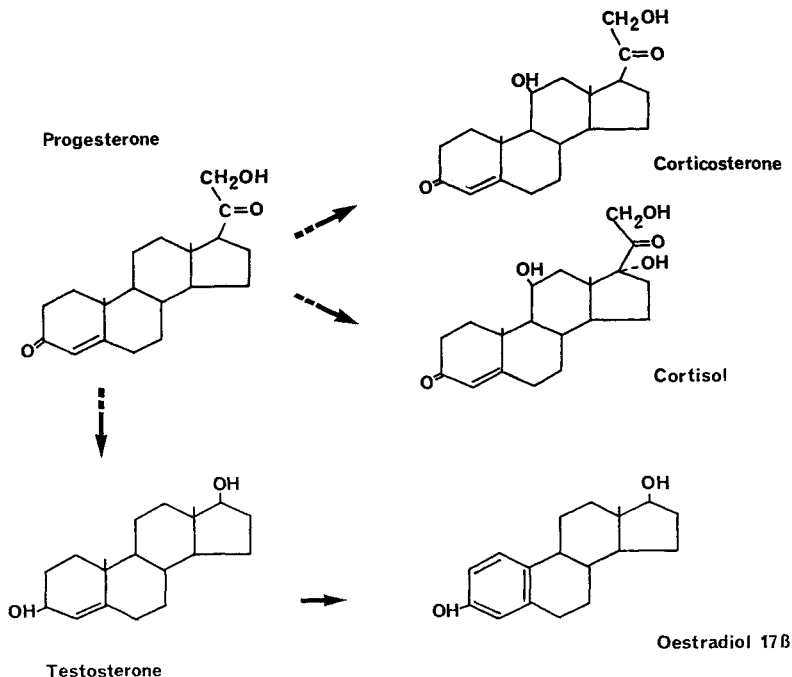

Figure 3. Structure of the main neuroactive steroids involved in feedback. Progesterone is enzymatically derived from cholesterol and processed to glucocorticoids (cortisol in man and corticosterone in rodents) and androgens (testosterone shown). An aromatase enzyme complex present in several tissues including brain converts testosterone to estradiol-17 β (E₂). Cortisol is derived from progesterone by way of the intermediary steroid, 17 α -hydroxyprogesterone.

within a relatively narrow band width. Within this band width, the basal secretion of ACTH and the gonadotropins is pulsatile. Plasma ACTH concentrations also show a circadian rhythm, with a peak in the morning and a trough approaching a nadir around midnight. In nocturnal animals, such as rodents, the phase of this rhythm is reversed so that the peak occurs just before darkness. The circadian rhythm of ACTH results in a circadian rhythm in the plasma concentrations of adrenal corticosteroids; cortisol in man and corticosterone in rodents. A key feature in both diurnal and nocturnal animals is that the plasma concentrations of the corticosteroids reach a peak just before the animal is due to wake from sleep; the levels are lowest just before or during sleep.

The frequency and amplitude of the gonadotropin pulses change during the menstrual cycle, thus allowing for frequency as well as amplitude modulation of gonadal function. Pulsatile hormone secretion is also important for preventing

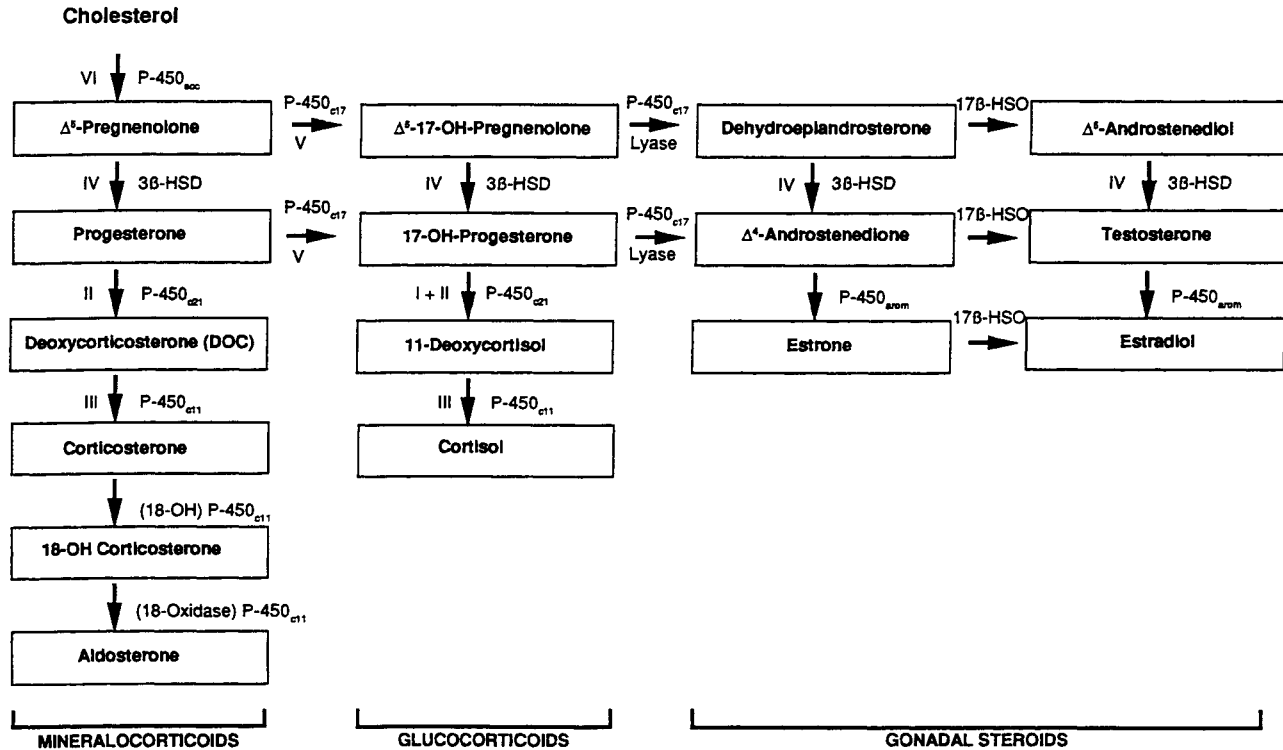

Figure 4. A diagrammatic representation of the steroid biosynthetic pathways in man. **I** to **VI** correspond to numbers for specific biosynthetic defects that result in congenital adrenal hyperplasia. P-450_{scc}, cholesterol side-chain cleavage; 3β-HSD, 3β-hydroxysteroid dehydrogenase/Δ^{4,5}-isomerase; P-450_{c21}, 21 hydroxylase; 17β-HSO, 17β-hydroxysteroid oxidoreductase; P-450_{c11} catalyzes 11-hydroxylation, as well as 18-hydroxylation and 18-oxidation; P-450_{c17} catalyzes 17-hydroxylation and 17,20 lyase activity. [From Grumbach and Conte (1992) with permission].

receptor desensitization or downregulation. Pulsatility of gonadotropin secretion plays a major role in determining the onset of estrus (i.e. the breeding season) in seasonal breeders such as the sheep, and in the onset of puberty.

The biosynthesis of steroid hormones is described by F.J. Zeelen in the *Molecular and Cellular Pharmacology Module*, but for ease of reference an outline of the structure of the principal steroids involved in feedback and the principal pathways involved in their biosynthesis are outlined in Figures 3 and 4. Enzyme deficiencies are one of the major causes of feedback dysregulation in man, resulting for example in the adrenogenital syndrome.

Steroid hormone action involves two types of mechanisms; genomic and extragenomic. The genomic action of steroid hormones is discussed in detail in Chapter 10 by Keller and Wahli. Relevant here are the facts that: (1) the genomic action takes minutes to hours, and (2) the action of the steroid-activated receptor is complex in that it involves the concerted action of the activated receptor binding to DNA response elements as monomers, homodimers, or heterodimers, together with other transcription factors. Extra-genomic mechanisms involve actions on the cell membrane and/or allosteric effects on enzymes. Both genomic and extragenomic types of action are probably involved in feedback mechanisms.

The extra-genomic effects of steroids were first suggested by the early studies of Hans Selye which showed that high doses of progesterone had an anesthetic effect. Subsequently, certain progesterone derivatives proved to be highly potent anesthetics; their action is on the GABA_A receptor where they potentiate the GABA agonist-mediated influx of chloride ions (Chadwick and Widdows, 1990). The extra-genomic effect of steroids takes seconds to minutes. Recently there has been an explosion of interest in the extra-genomic effects of steroids because pregnenolone and some of its derivatives which have anesthetic-like actions are synthesized in neurons and therefore termed neurosteroids. Although not synthesized in neurons, all the steroid hormones involved in feedback mechanisms cross the blood-brain barrier and are highly neuroactive.

NEGATIVE FEEDBACK IN THE HYPOTHALAMIC-PITUITARY-ADRENAL AXIS

Introduction

The circadian rhythm of ACTH and (the consequent) glucocorticoid secretion, which has a peak at the end and a nadir at the beginning of the sleep phase, is driven by a neural mechanism mediated mainly by the stress neurohormones. The twofold increase in ACTH signal between the nadir and the peak of the circadian rhythm results in a ninefold increase in corticosterone due to an increase in the responsiveness of the adrenal cortex (Chiappa and Fink, 1977; Engeland et al., 1977). In the unstressed state the HPA system operates in an approximately linear domain with all the loop variables (Figure 5) showing circadian periodicity (Yates and Maran,

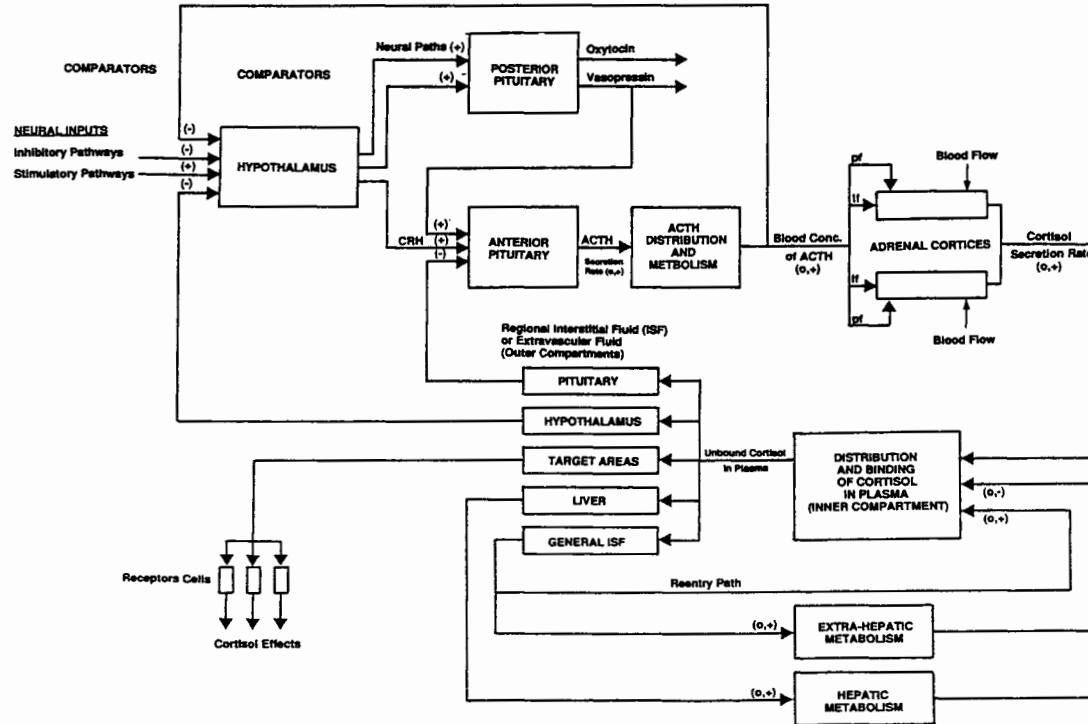

Figure 5. Block diagram of the hypothalamic-pituitary-adrenal glucocorticoid control system. *If*, input forcing of adrenal by ACTH; *pf*, parametric forcing of adrenal (hypertrophic effect) caused by ACTH over a longer time period. Parametric effect of changes in adrenal blood flow is also indicated. The designators 0,+ and 0,- indicate that signals in pathways are restricted in values (e.g., there are no negative masses or frequencies and removal processes or inhibitors are negative in effects). [From Yates and Maran (1975) with permission].

1975). Ultradian rhythms in plasma cortisol concentration, independent of ACTH concentrations, occur in man (Krieger, 1975) and the rhesus monkey (Holaday et al., 1977), in which they are highly synchronized between animals with a predominant periodicity of 85–90 min.

Superimposed upon basal ACTH secretion is the rapid and intensity-dependent ACTH/glucocorticoid response to stress. Yates and his co-workers (Yates and Maran, 1975) showed that glucocorticoids inhibit ACTH output by a fast rate-sensitive (i.e. the magnitude of inhibition is proportional to the rate of increase of plasma corticosteroids) and a delayed (about 2 h or more) level-sensitive mechanism. The former modifies the stress-induced secretion of ACTH (Engeland et al., 1977) while the latter is probably responsible for setting the output of ACTH when there is a prolonged increase or decrease in plasma glucocorticoid concentrations (Yates and Maran, 1975). This simple picture is complicated by changes in the neural drive mechanism. For example, the ACTH response to stress can be enhanced significantly by previous exposure to a stressful stimulus (Dallman and Jones, 1973), and, in adrenalectomized rats, the ACTH response to stress is significantly greater at the beginning than at the end of the sleep period (Engeland et al., 1977).

Principles of Negative Feedback Illustrated by the HPA System

Glucocorticoids exert their inhibitory action both on the brain and the pituitary gland (Figures 5 and 6). The paraventricular nuclei (PVN) of the hypothalamus contain the final common pathway neurons that mediate neural control of pituitary ACTH synthesis and release. The PVN receive stimulatory and inhibitory neural inputs, and an important projection from the suprachiasmatic nuclei (SCN), the key circadian oscillator in brain, and PVN drive is mediated by “stress neurohormones” released into hypophysial portal vessel blood. ACTH is released into the systemic circulation and stimulates adrenal corticosteroid synthesis and release. For negative feedback, the glucocorticoids (cortisol and corticosterone) are the most important of the adrenal steroids. The release of ACTH is pulsatile in man and is rapidly cleared from the blood both by metabolic degradation and distribution into several body compartments. The glucocorticoids are rapidly bound by albumin and a specific corticosteroid binding protein “transcortin” in man, and metabolized by several organs especially the liver and kidney (Figure 5). Only the unbound (free) glucocorticoids inhibit ACTH release, and therefore the strength of the negative feedback signal is determined by the degree of glucocorticoid binding and metabolism, as well as the magnitude of adrenal secretion (Figure 5).

In man there is also a corticotropin releasing factor-41 (CRF-41) binding protein in plasma, the major physiological role of which is likely to be in pregnancy when it mops up CRF-41 secreted by the placenta (Lowry, 1993).

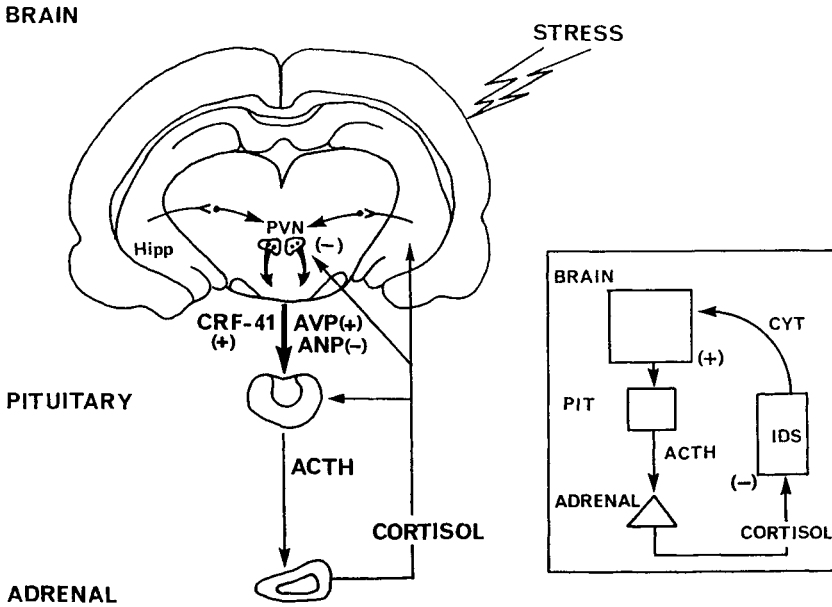

Figure 6. Schematic diagram of the elements involved in glucocorticoid negative feedback. The paraventricular nuclei (PVN) contain the main stress (final common pathway neurons) secreting both CRF-41 and AVP. The negative feedback action of cortisol (corticosterone in rodents) is exerted mainly on the PVN and the pituitary corticotropes. However, long-term effects mediated through the hippocampus (Hipp) and amygdala (not shown) cannot be excluded. There are several possible indirect connections between the hippocampus and the PVN. Neural control of ACTH secretion may also be mediated by a corticotropin inhibitory peptide, atrial natriuretic peptide (ANP). The inset shows the important inhibitory action of cortisol on the immune defence system (IDS). The IDS produces cytokines (CYT) which act on the brain to stimulate ACTH secretion. Cytokine secretion is inhibited by the negative feedback effect of glucocorticoids.

Neural Mechanisms: The Circadian Pacemaker

The circadian rhythm of ACTH secretion is driven by the SCN. In addition to the diurnal rhythm of corticosterone, the SCN generates the other key circadian rhythms in the body such as running activity, water and food intake, pineal N-acetyl transferase activity, and the regular occurrence of ovulation (Raisman and Brown-Grant, 1977). If any one of these functions is abnormal, then there is a high probability that the others will also be abnormal. The corticosterone rhythm is especially sensitive in that even partial lesions of the SCN which have no effect on any of the other circadian functions do disrupt the adrenal rhythm. Lesions of the SCN also affect sleep, resulting in an abnormally high proportion of slow wave and

paradoxical sleep during the dark phase (Ibuka and Kawamura, 1975). The SCN receive afferent projections from: (1) the retina (direct as well as indirect after relay in the ventral lateral geniculate nucleus), (2) the 5-HT raphe neurons, and (3) the hippocampus by way of the medial corticohypothalamic tract. Each of these inputs to the SCN is likely to affect the periodicity of the pacemaker: the retinal input affects the time of the light–dark cycle; the hippocampal input may be related to the sleep–wake cycle; the raphe input may be related to paradoxical sleep (Raisman and Brown-Grant, 1977; Watts et al., 1989). The raphe input also plays a major role in determining the amplitude of the diurnal ACTH peak (Szafarczyk et al., 1980). Although the central action of glucocorticoids is mainly on the PVN (see below), the 5-HT neurons of the DRN which project to the SCN have high concentrations of glucocorticoid receptors (Härfstrand et al., 1986). The SCN has direct projections to the PVN (Sawchenko and Swanson, 1983), and might also affect PVN function by way of its projections to the subparaventricular zone (Watts et al., 1989).

Although it has long been accepted that the SCN are responsible for generating circadian rhythms in the mammal, only recently has a gene responsible for circadian rhythmicity been identified (Vitaterna et al., 1994; King et al., 1997a). Discovered in the mouse, this “clock” gene encodes a novel member of the β HLH-PAS family of transcription factors (King et al., 1997b). In this respect, the Clock gene resembles the Period gene which generates circadian rhythms in *Drosophila*. King and associates (1997b) suggest that the presence of the PAS domain in both the Clock and Period genes reflects an evolutionary conserved feature of the circadian clock mechanism.

Corticosteroid Feedback at the Neural Level

Neural control of ACTH secretion is mediated mainly by the stress neurohormones, CRF-41 and arginine vasopressin (AVP) (Antoni, 1986; Chadwick et al., 1993), and under certain circumstances, oxytocin (Gibbs, 1986). Other neuropeptides such as angiotensin II have also been implicated as corticotropin-releasing factors, but direct evidence for this is not available. In fact, angiotensin II is not released into hypophysial portal blood (Plotsky et al., 1988; G. Fink and W.F. Ganong, unpublished).

Corticosteroid effects on the release of stress neurohormones. We have studied glucocorticoid feedback directly by measuring neuropeptide release into hypophysial portal blood (Fink et al., 1988). In a study designed to investigate intermediate (2–3 h) delayed (level-sensitive) glucocorticoid negative feedback, rats were adrenalectomized and then treated with the potent glucocorticoid agonist, dexamethasone. Adrenalectomy (3 weeks) induced a significant three- to fourfold increase in the release of both CRF-41 and AVP into rat hypophysial portal blood. Administration of dexamethasone 2.5 h before portal blood collection reduced significantly the release of AVP, but not CRF-41, into portal blood (Figure 7).

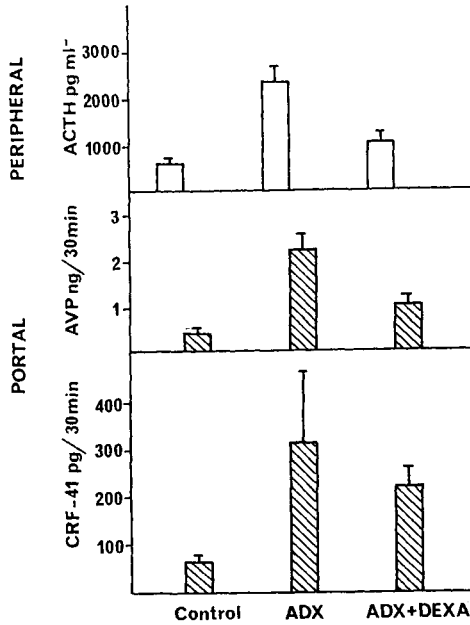

Figure 7. Illustrates the delayed negative feedback action of glucocorticoids in adult female Wistar rats anesthetized with sodium pentobarbitone. ACTH was measured in plasma taken immediately before sectioning of the pituitary stalk for the collection of hypophysial portal vessel blood. Adrenalectomy resulted in a fourfold increase in ACTH concentration and a similar increase in the output of AVP and CRF-41 into hypophysial portal vessel blood. The administration of dexamethasone resulted in a significant reduction in ACTH and AVP, but not CRF-41 release. [Modified from Fink et al. (1988) with permission of the Authors and Cambridge University Press].

Dexamethasone also blocked completely the ACTH response to CRF-41 in adrenalectomized rats (Figure 8). Oxytocin release into portal blood was unaffected by either adrenalectomy or dexamethasone treatment (Fink et al., 1988).

In a second study designed to study the fast and long-term effects of corticosterone on CRF-41, AVP, and oxytocin release, hypophysial portal vessel blood was collected from rats hypophysectomized 6–8 weeks before experimentation (Sheward and Fink, 1991). The output of CRF-41, AVP, and oxytocin into hypophysial portal blood was greatly increased in hypophysectomized compared with intact animals. The intravenous infusion of corticosterone (designed to test fast glucocorticoid feedback) had no significant effect on the release of any of the three neurohormones. Subcutaneous implantation of pellets of corticosterone, known to restore peripheral plasma concentrations of corticosterone to normal, resulted after

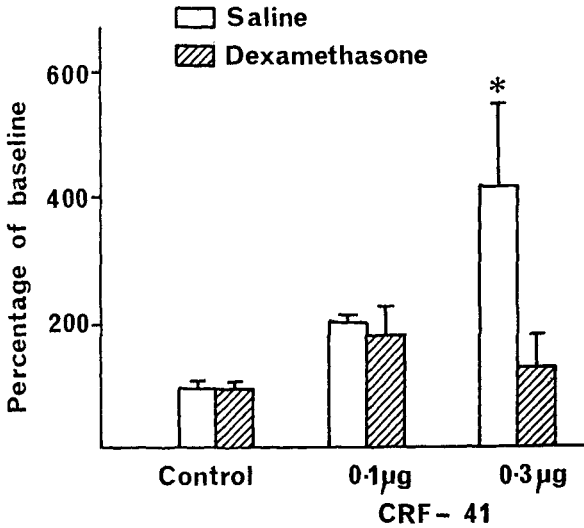

Figure 8. Mean (\pm SEM $n = 5$) percentage increases over the basal concentrations of ACTH after the injection of saline, 0.1 μ g CRF-41 or 3 μ g CRF-41. Female Wistar rats that had been adrenalectomized 3 weeks earlier were treated with either saline or dexamethasone 3 h before blood collection. * $P < 0.05$ when compared to the value in dexamethasone-treated rats. [From Fink et al. (1988) with permission of the Authors and Cambridge University Press].

5 days (designed to test long-term negative feedback) in a significant decrease in the output into portal blood of CRF-41 and AVP, but not oxytocin (Figure 9).

Taken together, our two studies suggest that *intermediate delayed* (2–3 h) glucocorticoid feedback is mediated by blockade of pituitary responsiveness to CRF-41 and a reduction in AVP output into hypophysial portal blood. That is, in this situation AVP is the regulatory or signaling hormone while CRF-41 is the “permissive” neurohormone. In contrast, *long-term* negative glucocorticoid feedback is due to decreased release of CRF-41, as well as AVP, into portal blood. Although differences in anesthesia and experimental design make comparisons difficult, our findings agree broadly with those of Plotsky and associates who showed that pharmacological “adrenalectomy” with metyrapone and aminoglutethiamide (which block glucocorticoid biosynthesis) resulted, after 3 days, in a significant increase in the release of both CRF-41 and AVP into hypophysial portal blood (Plotsky and Sawchenko, 1987). Intravenous infusion of corticosterone inhibited nitroprusside evoked CRF-41 release into portal blood, but had no effect on AVP release (Plotsky et al., 1986).

Glucocorticoid feedback effects on stress neurohormone synthesis. Glucocorticoids have potent inhibitory effects on CRF-41 synthesis as well as on CRF-41 release. Adrenalectomy is followed by a significant increase in CRF-41

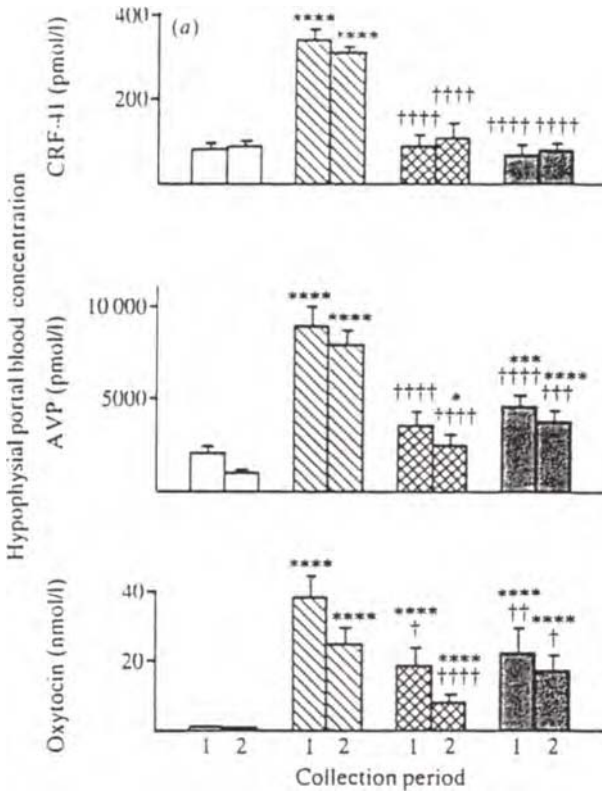

Figure 9. Shows that long-term corticosterone feedback inhibits CRF-41 and AVP release into hypophysial portal blood. Mean \pm SEM (a) concentrations and (b) contents of CRF-41, AVP, and oxytocin in hypophysial portal blood. Portal blood was collected for two consecutive 30-min periods from intact rats (*open bars*; $n = 10$), and from long-term hypophysectomized rats which had been implanted 5 days previously with wax (*hatched bars*; $n = 8$), 25% corticosterone (*cross-hatched bars*; $n = 7$) or 40% corticosterone-containing pellets (*shaded bars*; $n = 7$). * $P < 0.05$, ** $P < 0.02$, *** $P < 0.01$, **** $P < 0.001$ compared with the corresponding sample from pituitary intact control rats; † $P < 0.05$, †† $P < 0.02$, ††† $P < 0.01$, †††† $P < 0.001$ compared with the corresponding sample from hypophysectomized rats implanted with wax pellets (Mann-Whitney U-test). [From Sheward and Fink (1991) with the permission of the *Journal of Endocrinology* and the authors].

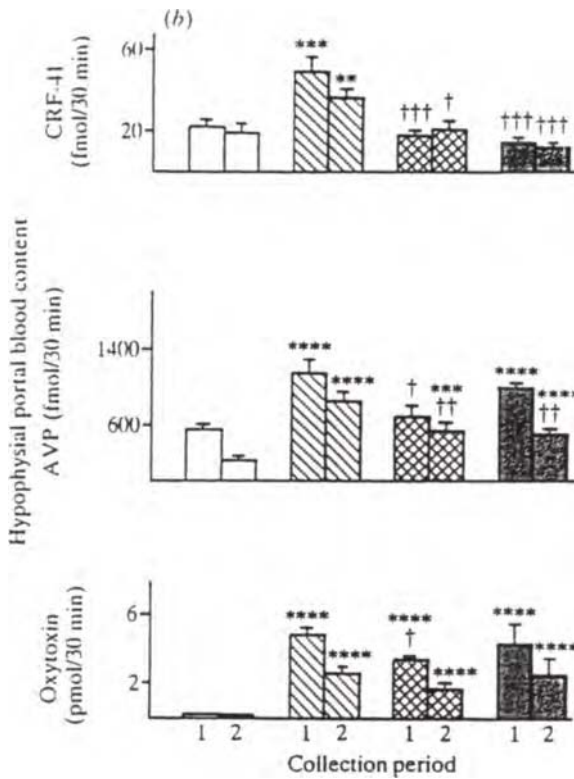

Figure 9. (Continued)

mRNA levels in the parvocellular PVN, and the high CRF-41 mRNA levels are significantly reduced by either corticosterone or dexamethasone (Swanson and Simmons, 1989; Lightman and Harbuz, 1993). As assessed by CRF-41-intron (CRF_{in}) *in situ* hybridization, the stimulation of CRF-41 gene transcription can be detected as early as 15 to 30 min after the injection of metyrapone (Herman et al., 1992a). This increase in CRF-41 gene transcription in the PVN was associated with a coincident increase in *c-fos* mRNA in the PVN. An increase in the levels of CRF-41 mRNA in the PVN after metyrapone injection was delayed by about 60 min (Herman et al., 1992a), possibly a function of the high resting levels of CRF-41 mRNA and the time taken to form mRNA from the CRF-41 primary transcript.

The effects of corticosterone and dexamethasone are dose-dependent, and can be demonstrated by systemic administration of the steroid, as well as by implantation of steroid pellets into the brain (Kovács and Mezey, 1987). This effect of glucocorticoids is cell-specific in that the glucocorticoid-induced decrease in CRF-41

mRNA was localized to the dorsomedial parvocellular neurons of the PVN, the major source of CRF-41 fiber projections to the median eminence (Swanson and Simmons, 1989). In contrast, glucocorticoid increased the levels of CRF-41 mRNA in parvocellular neurons that project to the brainstem and spinal cord (Swanson and Simmons, 1989). The implantation of dexamethasone micropellets in cerebral cortex, dorsal hippocampus, ventral subiculum, lateral septum, or amygdala had no effect on CRF-41 mRNA levels in the PVN (Kovács and Mezey, 1987). The molecular mechanism by which glucocorticoids regulate human CRF-41 gene expression is not clear. Inhibition might be mediated by the inhibitory interaction between the activated glucocorticoid receptor and the *c-jun* component of the AP-1 complex (Vamvakopoulos and Chrousos, 1994). Glucocorticoid stimulation of CRF-41 expression might be mediated by the potential 1/2 glucocorticoid response elements in the 5' region of the gene.

The concentrations of AVP mRNA in the dorsomedial parvocellular neurons of the PVN paralleled those of CRF-41 mRNA; that is, levels increased after adrenalectomy and decreased after treatment with glucocorticoids (Swanson and Simmons, 1989). Corticosterone treatment also produced a modest reduction in the levels of enkephalin mRNA in all four parts of the PVN, but glucocorticoid manipulation had no significant effect on the PVN concentrations of the mRNAs for angiotensin, cholecystokinin, preprotachykinin, and tyrosine hydroxylase (Swanson and Simmons, 1989). There is, therefore, a close correlation between the synthesis and release of CRF-41 and AVP. Whether this means that synthesis and release are mechanistically coupled is not established.

The data on the release and synthesis of stress neurohormones suggest that even though corticosteroid receptors are present in high concentration in parts of the brain remote from the hypothalamus, including the hippocampus and the monoaminergic nuclei in the hindbrain, central inhibition of CRF-41 and AVP synthesis and release is due to corticosteroid action mainly at the level of the PVN. Although a role for mineralocorticoid receptors cannot be excluded (Ratka et al., 1989), glucocorticoid receptors predominate.

Role of ANP in Glucocorticoid Inhibition

Recently, we showed that atrial natriuretic peptide (ANP) is released into hypophysial blood and, with the aid of immunoneutralization, that ANP is, possibly, *the* long-sought inhibitor of ACTH release (Lim et al., 1990; Fink et al., 1991; Sheward et al., 1991; Antoni et al., 1992; Fink et al., 1992; Lim et al., 1994). These *in vivo* data receive strong support from *in vitro* studies which showed that ANP inhibits ACTH release from pituitary cells in culture by way of a cyclic GMP mechanism (Dayanithi and Antoni, 1990). Our immunoneutralization studies suggest that glucocorticoid inhibition of ACTH release may be mediated at least in part by ANP (Fink et al., 1992). A consensus sequence for the glucocorticoid response element is present in the second intron of the ANP gene (Lang et al., 1987) and ANP gene

expression in and ANP release from cardiac cells are significantly increased by glucocorticoids (Lang et al., 1987; Fullerton et al., 1991).

Role of Hippocampus and Amygdala in Glucocorticoid Negative Feedback

It has long been assumed that the hippocampus and the amygdala play a major role in glucocorticoid negative feedback (e.g. Dallman et al., 1987; Tannahill et al., 1991). Although there are no known monosynaptic projections to the PVN from the hippocampus, potential di- or multisynaptic connections exist by way of: (1) the hippocampal fimbria–fornix system involving the lateral septum, bed nucleus of the stria terminalis (BNST), and anterior hypothalamus which project to the parvocellular PVN; and (2) the medial corticohypothalamic tract from the anteroventral subiculum to the ventromedial, arcuate, and suprachiasmatic nuclei of the hypothalamus (Herman et al., 1992b). The PVN also receive direct projections from the amygdala (Gray et al., 1989).

Pharmacological studies led Dallman et al. (1989) to conclude that corticosteroid negative feedback is mediated by an action on mineralocorticoid (type I) receptors in extra-hypothalamic neurons. However, hypothalamic deafferentation studies show that the negative feedback effect of glucocorticoids is exerted mainly on the PVN (Antoni et al., 1990). This point is reinforced by the fact that: (1) although electrical stimulation of the PVN resulted in a two- to threefold increase in CRF-41 release into hypophysial portal blood, stimulation of the hippocampus had no effect on the release of CRF-41, AVP, or oxytocin (Tannahill et al., 1991); (2) transection of the fornix, the major hippocampal–hypothalamic connection, had no significant effect on either basal or stress (nitroprusside induced hypotension) evoked CRF-41 release into hypophysial portal blood (Sapolsky et al., 1989); and (3) implantation of dexamethasone pellets in hippocampus had no effect on CRF-41 synthesis in the PVN (Kovács and Mezey, 1987). These findings do not exclude the possibility that the hippocampus modulates the hypothalamic–pituitary–adrenal system over a longer period as suggested by the careful lesion studies of Herman et al. (1992b) which showed that lateral fimbria–fornix lesions increased CRF-41 mRNA and AVP mRNA in the medial parvocellular PVN and plasma ACTH concentrations.

Stimulation and lesion studies of the amygdala and its projections to the hypothalamus have produced variable effects on the secretion of ACTH and corticosterone. Electrical stimulation of the amygdala produced a significant 50% reduction in the amount of CRF-41 released into hypophysial portal blood, but had no effect on the release of AVP, oxytocin, or ACTH (Tannahill et al., 1991).

The anatomical connections of the BNST, which receives rich projections from the amygdala and hippocampus and in turn projects to the parvocellular PVN (Sawchenko and Swanson, 1983; Herman et al., 1994), suggest that it could play a key role in the HPA control. Indeed, lesion of the anterior BNST resulted in a 30% decrease in CRF-41 mRNA levels in the PVN, while lesion of the posterior BNST resulted in a 13% increase in the level of CRF-41 mRNA in the PVN (Herman et

al., 1994). On the basis of these data, Herman et al. (1994) inferred that the anterior BNST integrates excitatory inputs mainly from the amygdala while the posterior BNST integrates inhibitory inputs mainly from the hippocampus. However, these inferences should be interpreted with caution since the changes in CRF-41 mRNA levels were relatively slight and not accompanied by any change in ACTH output.

In summary, although indirect data suggest that the hippocampus and amygdala are involved in HPA control, more detailed studies are required to determine the precise role of these prominent components of the limbic system in the glucocorticoid negative feedback control of ACTH secretion.

Corticosteroid Feedback at the Pituitary Level

As well as exerting a central effect, corticosteroids inhibit ACTH synthesis and release by an action at the level of the anterior pituitary gland (Dallman and Yates, 1969; Fink et al., 1988; Ratka et al., 1989; Canny et al., 1990). As in brain, the inhibitory action of corticosteroids on pituitary corticotropes is mediated by glucocorticoid [type II] receptors (Fink et al., 1988; Dayanithi and Antoni, 1989; Canny et al., 1990; Shipston and Antoni, 1991).

Glucocorticoid inhibition of ACTH release. Studies on dispersed pituitary cells with inhibitors of mRNA and protein synthesis have shown that both the rapid and delayed glucocorticoid inhibition of ACTH release depend upon mRNA and protein synthesis (Dayanithi and Antoni, 1989; Shipston and Antoni, 1991). The precise nature of the protein mediator of glucocorticoid inhibition has yet to be established, but two possible mediators have been suggested. First, studies by Antoni and associates on a mouse pituitary tumor AtT20 cell line have implicated calmodulin and calcineurin (Shipston et al., 1994). Briefly, Shipston et al. (1994) propose that calcineurin, a Ca^{2+} -calmodulin regulated phosphatase, acts as a Ca^{2+} sensor. Increased intracellular Ca^{2+} concentrations induced by CRF-41 stimulation of adenylyl cyclase, together with calmodulin activate calcineurin which inhibits the activity of the adenylyl cyclase, and thereby, inhibits further Ca^{2+} influx through ligand gated ion channels. That is, calcineurin plays a pivotal role in an intracellular negative feedback loop which moderates intracellular Ca^{2+} concentrations, and thereby, ACTH release. Glucocorticoids, by stimulating the synthesis of calmodulin, potentiate this intracellular negative feedback control system. Antoni and colleagues have recently demonstrated that the adenylyl cyclase involved in this feedback mechanism is a novel form, type 9 (Antoni et al., 1995; Paterson et al., 1995). It remains to be determined whether a similar system operates also in normal pituitary cells. Second, lipocortin 1, a Ca^{2+} /phospholipid binding protein shown to mediate certain antiinflammatory actions of the glucocorticoids, has also been implicated as a possible mediator of glucocorticoid inhibition of ACTH release (Taylor et al., 1993). The two propositions are not mutually exclusive. Once firmly established, the precise intracellular mechanism that mediates glucocorticoid nega-

tive feedback may point to important novel therapeutic approaches which could mimic the antiinflammatory and immunosuppressant actions of glucocorticoids.

Glucocorticoid inhibition of proopiomelanocortin gene expression.

Glucocorticoids exert potent inhibitory effects on the expression of the ACTH precursor, proopiomelanocortin (POMC), in the anterior lobe of the pituitary gland (Gagner and Drouin, 1985; Tremblay et al., 1988). Transcription assays showed that in male Sprague-Dawley rats dexamethasone inhibited POMC gene transcription by 10-fold within 30 min of a single injection of the glucocorticoid. Inhibition of POMC transcription was paralleled by a dramatic fall in plasma ACTH concentrations (Gagner and Drouin, 1985). The same study showed that CRF-41 stimulated POMC transcription by nearly twofold within 15 min and this coincided with a massive increase in ACTH release. The action of dexamethasone is cell-specific in that the steroid had no effect on the transcription rate of POMC in primary cultures of neurointermediate lobe cells (Gagner and Drouin, 1985).

Studies in transgenic mice showed that no more than 769 base pairs of the rat POMC promoter are required for cell-specific expression and glucocorticoid inhibition of the POMC gene in the anterior pituitary gland (Tremblay et al., 1988). A good deal is known about the glucocorticoid response elements in the POMC promoter and the transcription factors involved in POMC expression, but the precise molecular mechanism of glucocorticoid inhibition of POMC transcription remains to be elucidated (Drouin et al., 1993, Therrien and Drouin, 1993a, b).

Possible Role of 11 β -Hydroxysteroid Dehydrogenase

11 β -Hydroxysteroid dehydrogenase (11 β -OHSD) rapidly converts the active glucocorticoids, cortisol, and corticosterone to inactive 11-keto products, cortisone and 11-dehydrocorticosterone, respectively. In the kidney, this mechanism is thought to prevent mineralocorticoid excess, since both cortisol and corticosterone bind to mineralocorticoid receptors with high affinity and are also present in the systemic circulation at concentrations about 1000-fold greater than aldosterone (Edwards et al., 1988). High concentrations of 11 β -OHSD are also present in the PVN (Seckl et al., 1993), and we recently demonstrated that administration of glycyrrhetic acid, an inhibitor of 11 β -OHSD, resulted in a significant decrease in CRF-41 release into hypophysial portal blood. These data suggest that 11 β -OHSD may play a part in determining the strength of the glucocorticoid feedback signal on CRF-41 neurons (Seckl et al., 1993). However, in contrast to its effect on CRF-41, glycyrrhetic acid stimulated the release of AVP and oxytocin into hypophysial portal blood (Seckl et al., 1993). This apparent paradox may be explained by the recent discovery that there are two distinct 11 β -OHSD enzymes of which type 1 is by far the more prevalent in brain and pituitary gland (Seckl, 1997). The type 1 enzyme may in fact function mainly as an 11 β -reductase; that is, it activates inert corticosteroids. The type 2 enzyme is an exclusive 11 β -dehydro-

genase (glucocorticoid inactivating enzyme), which has aldosterone-selective actions on the brain (i.e., blood pressure and salt appetite). Our earlier findings (Seckl et al., 1993) must therefore be interpreted in the context of this more complex mechanism.

Functional Importance of Glucocorticoid Negative Feedback

Glucocorticoid feedback inhibition of ACTH release protects the organism against the deleterious effects of hypercortisolemia (Munck et al., 1984). Whether due to endogenous causes such as Cushing's Syndrome or extrinsic causes such as trauma or chronic stress, hypercortisolemia has at least two major deleterious effects. First, it suppresses the immune-inflammatory defence system and so incapacitates the animal's ability to respond to infection by pathogenic microorganisms (Dallman, 1993; Thompson, 1994). Second, persistent hypercortisolemia will have major adverse effects on intermediary metabolism, resulting eventually in all the features of Cushing's Syndrome, viz., android obesity, diabetes mellitus, hyperlipidemia, hypertension, and osteoporosis.

Clinical Manifestations of Disordered Glucocorticoid Feedback Regulation

No attempt is made here to give a detailed account of the clinical effects of disruption of feedback control within the HPA system. Rather, reference will simply be made to two clinical examples which underscore the principles of negative feedback and illustrate the consequences of disruption of normal feedback control in the HPA system. The first example is due to defects at the level of the adrenal cortex while the second is probably due to an alteration in the central set-point of the negative feedback control system.

Congenital Adrenal Hyperplasia: Failure of Glucocorticoid Negative Feedback

There are several types of inherited enzymatic defects in cortisol synthesis which result in congenital adrenal hyperplasia (CAH), also known as the adrenogenital syndrome (Orth et al., 1992). By far the most common form is due to a deficiency of P-450₂₁ (₂₁hydroxylase; see Figure 4). Excessive androgen secretion results from a failure of glucocorticoid negative feedback and consequent high ACTH secretion. High androgen levels may lead to virilization of females *in utero*. About two-thirds of patients also have mineralocorticoid deficiency resulting in salt wasting. If not obvious during the neonatal period, androgen excess may appear in early infancy, resulting in sexual precocity in boys and clitoral enlargement and pubic hair growth in girls. Excess androgen accelerates linear growth and epiphyseal closure leading ultimately to diminished adult height. In adult women with untreated CAH, reproductive function is impaired due to: (1) disturbance of normal menstrual cycles as a consequence of the high plasma progesterone and androgen concentrations,

and (2) labial fusion which prevents successful coitus. The former can be corrected by glucocorticoid replacement therapy while the latter can be treated by surgery.

The P-450_{c21} deficiency is transmitted as a single gene autosomal recessive trait linked to the major histocompatibility complex locus on the short arm of chromosome 6 (Orth et al., 1992). An allelic variable of classical 21-hydroxylase deficiency results in a late onset type which frequently presents with clinical features similar to those of polycystic ovarian disease (Dewailly et al., 1986).

Deficiency of P450_{c11} (11 β -hydroxylase) is a much less common cause of CAH. As in the case of P450_{c21} deficiency, it is transmitted as an autosomal recessive disorder (for detailed genetics see White et al., 1994), but not linked to the HLA locus. As in the case of P450_{c21} deficiency, a deficiency in P450_{c11} results in impaired glucocorticoid feedback, and a consequent hypersecretion of ACTH and adrenal androgens. The condition is treated with glucocorticoid replacement therapy.

Much rarer forms of CAH are produced by deficiencies of 17 α -hydroxylase and 3 β -hydroxysteroid dehydrogenase which result in defective adrenal androgen, as well as glucocorticoid secretion (Orth et al., 1992).

Hypercortisolemia in Major Depression: Possibly Due to an Altered Set-Point in Glucocorticoid Negative Feedback

Major depressive disorder is characterized by a significant increase in plasma cortisol concentrations (hypercortisolemia) which is most prominent at the nadir of the circadian rhythm, towards midnight (Figure 10; Christie et al., 1986). It was first thought that hypercortisolemia and resistance to suppression of endogenous cortisol secretion by dexamethasone were specific features of major depression (e.g. Carroll et al., 1981). This led to the hope that the dexamethasone suppression test could be used as a specific biological marker of depression. However, extensive studies have shown that hypercortisolemia and resistance to dexamethasone suppression are also associated with other types of psychoses, such as schizoaffective disorder (Figure 10; Christie et al., 1986; Copolov et al., 1989) and organic dementia including the Alzheimer type (Figure 11; Christie et al., 1987). Hypercortisolemia in psychotic patients is not due to the stress of hospitalization (Christie et al., 1986).

Hypercortisolemia in major depression is associated with a threefold increase in the mean plasma concentrations of β -endorphin (Goodwin et al., 1993). In fact, resistance of β -endorphin to dexamethasone suppression appears to be a more robust marker of major depression than cortisol (Young et al., 1993). Thus, in a study of 73 patients with major depressive disorder, 39 (53%) showed β -endorphin "nonsuppression" to dexamethasone while only eight patients (11%) showed cortisol "nonsuppression" (Young et al., 1993). These findings suggest that hypercortisolemia in major depression is due to a resistance of the brain-pituitary-ACTH module to glucocorticoid negative feedback; that is, an elevation of the set-point

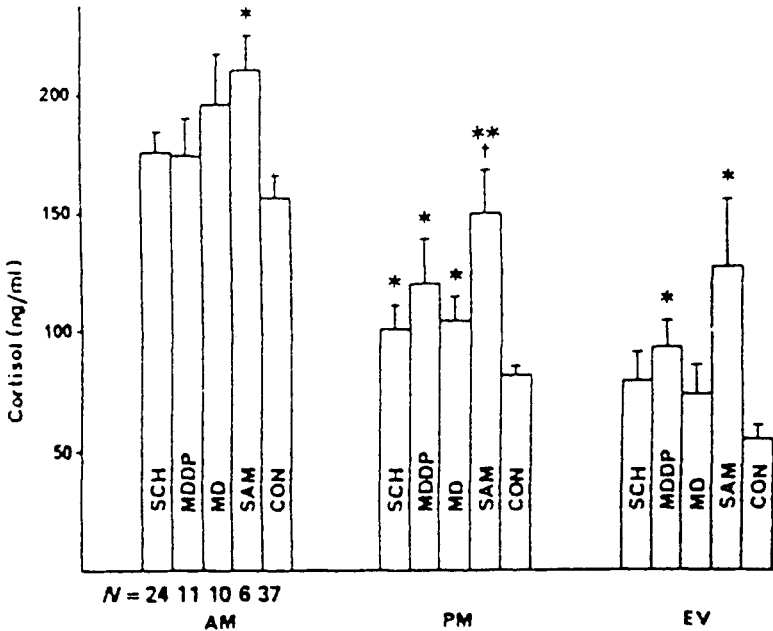

Figure 10. Hypercortisolemia in major psychoses. Plasma cortisol concentrations (mean \pm SE) in patients classified according to the Research Diagnostic Criteria. Schizophrenia (SCH), major depressive disorder psychotic subtype (MDDP), manic disorder (MD), schizoaffective disorder manic type (SAM), control subjects (CON). a.m. = mean of 07.00, 07.30, 08.00 h; p.m. = mean of 15.00, 15.30, 16.00 h; ev = mean of 23.00, 23.30, 24.00 h. * v control subjects $P < 0.05$, ** v control subjects $P < 0.01$, † v schizophrenia $P < 0.05$. [From Christie et al. (1986) with permission].

for glucocorticoid feedback. The precise mechanism remains to be determined, but decreased responsiveness of the PVN and/or pituitary to glucocorticoid negative feedback is a likely explanation. Reduced neural responsiveness in the PVN could be caused by transynaptic changes triggered by the limbic system and frontal cortex. Hypercortisolemia in depression may also be due in part to increased responsiveness of the adrenal cortex to ACTH (Gerken and Holsboer, 1986). Resistance to dexamethasone suppression was reported to be directly related to baseline cortisol values and the age of the patients (Maes et al., 1991).

Central 5-HT mechanisms may also play a role in that lesions of 5-HT inputs to the SCN with the neurohormone 5,7-dihydroxytryptamine reduced the amplitude of the circadian ACTH peak by about 50%, but had no effect on period length (Szafarczyk et al., 1980). This suggests that increased "drive" of the 5-HT projection from raphe to SCN could result in hypercortisolemia.

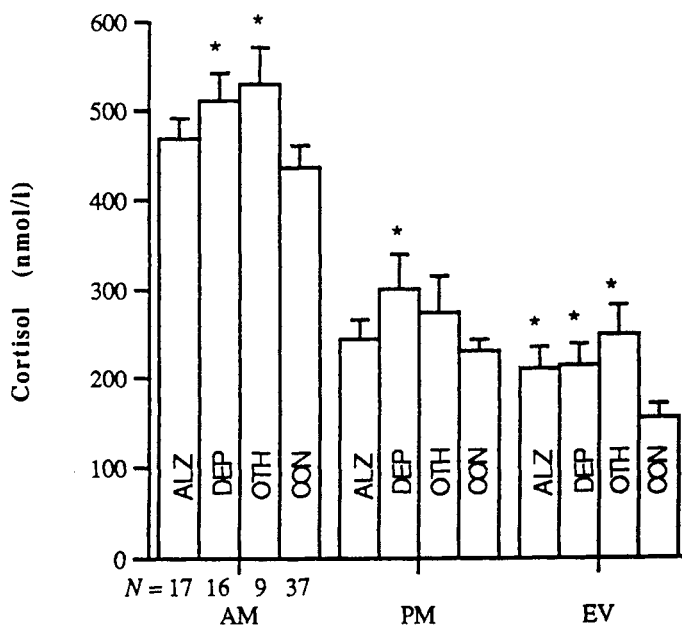

Figure 11. Hypercortisolemia in dementia and major depression. Plasma cortisol concentrations (mean \pm SE) in patients with Alzheimer's type dementia (ALZ), major depressive disorder (DEP), other dementias (OTH) and control subjects matched for age and sex. * Significantly different ($P < 0.05$) from control subjects. [From Christie et al. (1987) with permission].

Why do patients with hypercortisolemia of major depression fail to show the clinical features of Cushing's syndrome? One possible explanation is that in major depression the circadian rhythm of cortisol remains intact while in Cushing's syndrome it is disrupted, thereby exposing the body to continuously high levels of cortisol. In patients with major depression there is also a significant state-dependent reduction ("downregulation") of peripheral cortisol receptors as assessed by measurements in lymphocytes (Gormley et al., 1985; Whalley et al., 1986; Hunter et al., 1988). Resistance to dexamethasone suppression, the *sine qua non* of Cushing's syndrome, is not universal in patients with major depression. In fact, some studies show that only a small proportion of depressives show dexamethasone resistance (Young et al., 1993).

Of equal or greater importance is the question as to whether hypercortisolemia in major depression and other psychoses exerts any deleterious effects on the patient. Two possible deleterious effects have been suggested. The first, suppression of the immune defence system, which may predispose the patient to inflammatory disorders or cancer (e.g. Munck et al., 1984; Besedovsky et al., 1986; Berkenbosh

et al., 1992), has a biological basis in the glucocorticoid-induced apoptosis of thymic lymphocytes and various normal lymphoid cells (Thompson, 1994). Indeed, by far the most common therapeutic use of glucocorticoids is to suppress inflammation. However, in spite of the cellular data, the question of whether hypercortisolemia predisposes patients with depression to cancer or inflammatory disorders still awaits robust evidence.

The second postulated deleterious effect is on cell death in the nervous system. Championed mainly by Sapolsky (1992), the hypothesis is that hypercortisolemia promotes the death of nerve cells in the hippocampus, and exacerbates the effects of neurotoxins. So far, the evidence comes from rodents and, therefore, before firm conclusions are drawn regarding the possible deleterious effect of hypercortisolemia in man, evidence must first be obtained from studies in human brain. In this respect, a detailed study of human postmortem brain showed that, as assessed by *in situ* hybridization histochemistry, the concentrations of glucocorticoid and mineralocorticoid receptor mRNA in all subfields of the hippocampus were similar in patients with Alzheimer's type dementia compared with that in normal age-matched control subjects (Seckl et al., 1993). This contrasts with the rat where there is a significant decrease with age in glucocorticoid receptor density in the hippocampus. There are several plausible explanations of these findings, but none which support a direct link between hypercortisolemia and hippocampal cell death in Alzheimer's type dementia.

Summary

Homeostasis within the HPA is maintained by a precise negative feedback mechanism by which corticosteroids, mainly the glucocorticoids, corticosterone, or cortisol, inhibit ACTH synthesis and release. The major sites of negative feedback are the PVN, where glucocorticoids inhibit CRF-41 and AVP synthesis and release, and the pituitary where they block the ACTH response to CRF-41 and inhibit POMC/ACTH synthesis. While the limbic system, and especially the hippocampus and amygdala, has long been implicated in glucocorticoid negative feedback, its precise role remains to be elucidated. The adrenogenital syndrome illustrates the effect of a disruption of the glucocorticoid negative feedback loop, while hypercortisolemia, a prominent feature of major depressive disorder and other psychoses and organic dementias, is probably due to elevation of the set-point of the glucocorticoid negative feedback in the HPA system. Establishment of the precise cause of this change in feedback set-point may provide an important insight into the central disorder in depression. The hypercortisolemia may by inhibiting the immune-inflammatory defence system have deleterious effects in the patient, and animal studies tentatively suggest that there may also be deleterious effects on the viability of hippocampal neurons.

NEGATIVE FEEDBACK IN THE HYPOTHALAMIC–PITUITARY–GONADAL AXIS

Introduction

For most of the reproductive life, plasma gonadotropin levels are kept within a relatively low range by the negative feedback of gonadal steroids and, in the case of FSH, inhibin (for review see Steinberger and Ward, 1987). Gonadectomy in several species including man is followed by a massive increase in gonadotropin release, and this occurs naturally after menopause in the human female (Fink, 1977). The administration of gonadal steroids suppresses plasma gonadotropin concentrations. Within the bandwidth “allowed” by the HPG comparator, gonadotropin secretion is pulsatile. In the human female, the frequency (ca. one pulse per 1 to 4 h) and amplitude of the gonadotropin pulses change during the menstrual cycle (Yen et al., 1972). Pulsatile release plays an important signaling role in that it permits frequency, as well as amplitude modulation, and also prevents receptor downregulation.

Gonadotropin Pulses: The Pulse Generator

The concept of the LHRH pulse generator was first proposed by Ernst Knobil as a consequence of his elegant pioneering studies in the rhesus monkey (Dierschke et al., 1970; Knobil, 1974, 1980). The LHRH/LH pulse generator differs from the LHRH/LH surge generator (Figure 12) in that: (1) the pulse, but not the surge, generator is active in the male, as well as the female rat; (2) pulsatile, but not surge, LH release occurs in female rats that have been masculinized by neonatal exposure to androgen, or exposed to constant illumination; (3) deafferentation of the medial basal hypothalamus blocks the surge, but not the pulsatile release of LH; and (4) increased central noradrenergic activity inhibits LHRH/LH pulses, but facilitates the LHRH/LH surge. Both generators, however, are inhibited by opioids in rat, monkey and man (Gindoff et al., 1988).

The apparent location of the pulse generator in the medial basal hypothalamus of the rat is puzzling because it contains few, if any, LHRH neuronal cell bodies. Possibly the LHRH neurons responsible for producing LHRH pulses project to the median eminence by way of the subchiasmatic pathway which might not be severed by hypothalamic deafferentation. In the rhesus monkey, there are relatively many LHRH cell bodies in the medial basal hypothalamus. Pulsatile LH release in the rhesus monkey is accompanied by spikes of hypothalamic multiple unit activity (MUA) (Kesner et al., 1987). The frequency and amplitude of these MUA spikes is generally related to LH pulses (e.g. Williams et al., 1990; Grosser et al., 1993; O’Byrne et al., 1993). The inference that these MUA spikes are causally linked to LH pulses raises the intriguing possibility that the medial basal hypothalamus of the rhesus monkey is concerned primarily with the LH pulse generator.

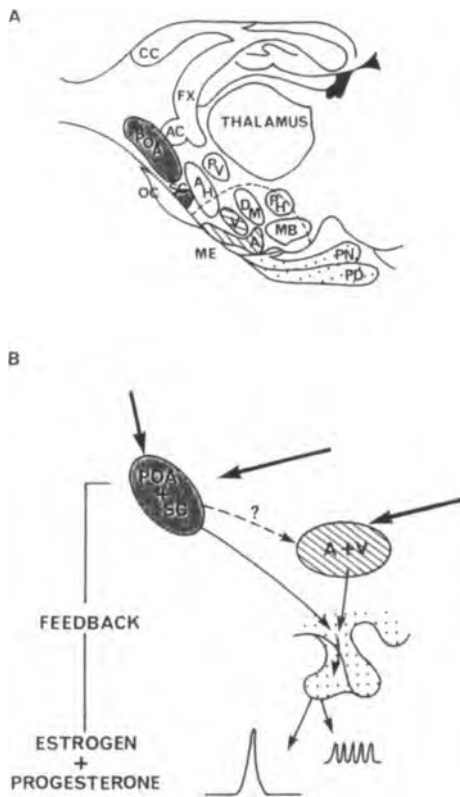

Figure 12. (A) Schematic diagram of a sagittal section of the rat brain and pituitary gland showing the main hypothalamic nuclei. The medial basal hypothalamus is enclosed by the dashed line. (B) Schematic diagram of the LH surge and pulse generators. The LH surge generator appears to be located in the region of the preoptic and suprachiasmatic nuclei, whereas the pulse generator is thought to be in the medial basal hypothalamus. Both generators are influenced by neurons extrinsic and intrinsic to the hypothalamus. It is not clear whether and, if so, how the generators are linked. Arrows indicate control inputs from exhypothalamic regions of the central nervous system and the positive- and negative-feedback systems. The important abbreviations are: POA, preoptic area; SC, suprachiasmatic nuclei; AC, anterior commissure; CC, corpus callosum; FX, fornix; A, arcuate nuclei; V, ventromedial hypothalamic nucleus; ME, median eminence; OC, optic chiasm; PD, pars distalis of the pituitary gland; PN, pars nervosa of the pituitary gland. [From Fink (1988a) with permission].

Why is the "Basal" Secretion of LHRH or LH Pulsatile?

Pulsatile LHRH and gonadotropin secretion may simply reflect an inherent property of neuroendocrine and endocrine cells. However, the changing frequency and amplitude of the gonadotropin pulses during the menstrual and estrous cycles suggest that pulsatile gonadotropin release serves a physiological signaling purpose in that control within the hypothalamic–pituitary gonadal system depends as much on frequency as on amplitude modulation. This applies especially in seasonal breeders, such as the sheep, where the frequency and amplitude of the LHRH/LH pulses vary considerably with the time of year and appear to play a crucial role in switching the gonads on and off (Lincoln and Short, 1980; Barrell et al., 1992; Karsch et al., 1993). Similarly, the frequency and amplitude of LHRH/LH pulses play a major role in initiating gonadal activity at puberty (Grumbach and Kaplan, 1990). In man, LH pulses associated with rapid eye movement sleep occur selectively at puberty, and the same phenomenon occurs in anorexia nervosa as these patients pass into and out of the crisis phase of the illness.

The pulsatile administration of LHRH at frequencies of about one per hour in the hypogonadal mouse or rhesus monkey is much more effective than either continuous infusions or a single large bolus injection of LHRH in stimulating gonadotropin synthesis and release, and thereby, establishing and/or maintaining the normal function of the gonads. Pulsatile LHRH increases markedly the amount of LHRH receptor mRNA in dispersed rat pituitary cells while continuous exposure to LHRH or LHRH agonists results in LHRH receptor downregulation (desensitization) which, in turn, leads to a reduction in gonadotropin output (Kaiser et al., 1993). The frequency of LHRH pulses also sets the level of pituitary responsiveness to LHRH by way of the self-priming effect of LHRH (Fink et al., 1976, and below).

Thus, pulsatile LHRH and gonadotropin release serves as a signaling device that allows for frequency and amplitude modulation of hormone effects, and as well prevents receptor downregulation and the consequent development of refractoriness in the hypothalamic–pituitary–gonadal system.

Sex Difference in Steroid Control of Pulsatile Release

There appears to be a sex difference in the nature of negative feedback control of pulsatile LHRH release. In the female, estradiol-17 β (E₂) moderates the amplitude as well as the frequency of LHRH pulses. Thus, ovariectomy in the rat is followed by an increase in the mean concentration of LHRH in portal vessel blood which parallels the increase in peripheral plasma LH concentration (Sarkar and Fink, 1980). This increase in mean LHRH output reflects a massive increase in the amplitude of LHRH pulses which 16 to 24 days after ovariectomy achieve values of over 1000 pg/mL of hypophysial portal blood, 10-fold greater than the ovulatory surge values of about 100–150 pg/mL and more than 50-fold greater than basal values in intact rats of less than 20 pg/mL. The LHRH spikes are rapidly (within

30 min) inhibited by E_2 administered intravenously (Sarkar and Fink, 1980). Similarly, E_2 reduces significantly the amplitude of LHRH pulses before the preovulatory surge in the sheep (Evans et al., 1994), and intravenous infusion of E_2 inhibits LHRH release and hypothalamic multiple unit spike activity in the rhesus monkey (Kesner et al., 1987).

By contrast, in male rats the release of LHRH, assessed by measurements in portal blood or by push-pull cannula, is not increased by castration (Brar et al., 1985; Dluzen and Ramirez, 1985; Levine and Duffy, 1988). Castration in the ram leads to a significant increase in the frequency, but not amplitude of LHRH pulses in hypophysial portal blood (Caraty and Locatelli, 1988). The pulse frequency in long-term castrated rams was 1 pulse/36 min compared with 1 pulse/70 min in short-term castrates and 1 pulse/120–240 min in intact rams. Castration also resulted in increased pulse frequency, but not amplitude in the male rat, as assessed by push-pull cannula (Levine and Duffy, 1988). This suggests that the massive increase in plasma LH concentrations in castrated males (e.g. Steiner et al., 1982) is due to increased pituitary responsiveness to LHRH as a consequence of LHRH self-priming induced by increased LHRH pulse frequency (see below).

These *in vivo* data are complemented by the results of *in vitro* studies which showed that LHRH secretion from explanted hypothalami from castrated male rats is consistently diminished compared with that from hypothalami from intact rats (Rudenstein et al., 1979; Nikolarakis et al., 1986; Kalra et al., 1987; Kalra and Kalra, 1989; Wetsel and Negro-Vilar, 1989). Castration is also followed by a progressive and significant fall in hypothalamic content of the mature LHRH decapeptide (Shin and Howitt, 1975; Badger et al., 1978; Cicero et al., 1980; Kalra and Kalra, 1980; Roselli et al., 1990). The fall in hypothalamic LHRH content is not coupled with any reduction in LHRH gene expression, but could be due in part to decreased conversion of proLHRH to LHRH (Roselli et al., 1990).

This apparent sex difference suggests that masculinization of the brain by androgen changes the nature of the LHRH pulse generator so that frequency modulation predominates in the male while both amplitude and frequency modulation of LHRH pulses control LH release in the female.

Summary

Although the phenomenon of gonadal steroid negative feedback has long been known and underpins the most widely used chemical contraceptive (i.e. "the pill"), the precise mechanism still remains to be established. The action of E_2 depends upon its concentration in plasma and whether it has been preceded or followed by increased plasma concentrations of progesterone (for details see below). The release of LHRH and LH is pulsatile, and the pulses are enhanced by gonadectomy. Estrogen and androgens rapidly inhibit LHRH/LH pulses. The pulsatile nature of LHRH and LH release serves as an important signaling device and also prevents

desensitization of LHRH and LH receptors. LHRH pulse frequency predominates in the male while pulse amplitude as well as frequency are important in the female.

STEROID POSITIVE FEEDBACK: SPONTANEOUS GONADOTROPIN AND PROLACTIN SURGES

In spontaneously ovulating mammals, basal hormone secretion is punctuated by the dramatic ovulatory surge of gonadotropin. The frequency of the gonadotropin surge varies between species; once every 4 to 5 days in the estrous cycle of the rat and about once every 28 days in the menstrual cycle in primates. The ovulatory gonadotropin surge, accompanied by a surge of prolactin in rat and man (Djahanbakhch et al., 1984; Fink, 1988a) is triggered by increased secretion of E_2 , reinforced in some species by progesterone. The term "positive feedback" is frequently used to describe the stimulation by E_2 and progesterone of gonadotropin and prolactin release. However, even though the positive feedback cascade (see below) results in destruction of a major component of the system, rupture of the ovarian follicles, the LH surge terminates well before ovulation and so E_2 stimulation of the LHRH/LH surge, potentiation of pituitary responsiveness to LHRH, and the self-priming effect of LHRH are, strictly speaking, *servomechanisms*. In the case of prolactin, there is in fact no evidence of a feedback loop, but the surge is mentioned briefly here because of its association with the LH surge and the heuristic value of studying the two surge mechanisms in parallel.

General Overview of the Mechanism of the Spontaneous Gonadotropin Surge

Follicle-stimulating hormone (FSH) stimulates the growth and maturation of ovarian follicles, whereas LH causes rupture of the follicle (Figure 13). Under the influence of basal levels of FSH and LH, the granulosa cells of the follicle secrete estrogen, mainly estradiol-17 β , and after follicular rupture, the granulosa cells proliferate and undergo structural and biochemical changes that result in the formation of the corpus luteum, which secretes large amounts of progesterone as well as E_2 . The synthesis and release of LH and FSH are regulated by LHRH, which is synthesized by neurons in the hypothalamus, released into the hypophysial portal vessels, and thereby conveyed to the anterior pituitary gland. Steroid modulation of LHRH synthesis and release is mediated by neurons in forebrain and hindbrain which are sensitive to E_2 .

The LH surge is the most dramatic spontaneous signal emitted by the hypothalamic-pituitary system and depends on resonance between neural and ovarian oscillators. The mechanism of the LH surge has been studied most extensively in the rat, which, allowing for a much shorter cycle length, has hormonal profiles that resemble those that occur during the menstrual cycle in women (Figure 14). The cascade of events that leads to the LH surge is initiated by the increased secretion

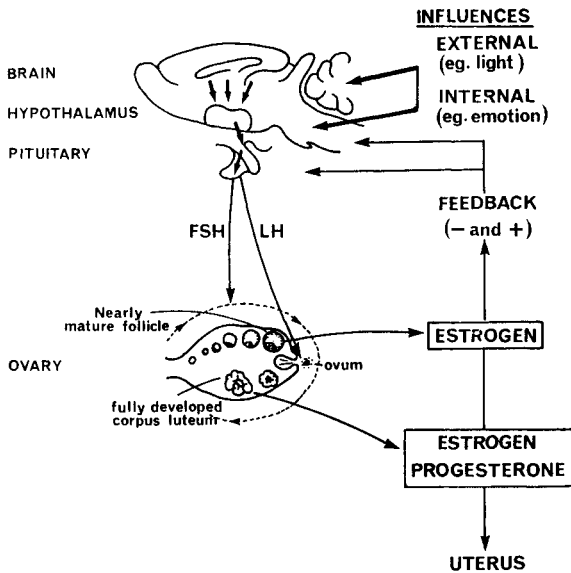

Figure 13. Schematic diagram of the control of the ovarian cycle by follicle-stimulating hormone (FSH) and luteinizing-hormone (LH) released from the anterior pituitary gland. The secretion of LH and FSH is controlled by the brain by way of luteinizing-hormone-releasing hormone (LHRH), a decapeptide that is released from hypothalamic neurons into the hypophysial portal vessels. The release of LHRH from hypothalamic neurons is influenced by external and internal factors acting by way of central nervous pathways, and the system is regulated by positive- and negative-feedback control involving estrogen and progesterone secreted by the ovary. Estrogen and progesterone act on the uterus to prepare the endometrium for implantation of the zygote should fertilization occur. Not shown, for the sake of simplicity, is the protein, inhibin, which is secreted by ovarian follicles and inhibits FSH release. [From Fink (1988a) with permission].

of E_2 (Knobil, 1974; Legan and Karsch, 1975; Fink, 1979a) (Figure 15). Elevated concentrations of E_2 : (1) induce the expression of a daily neural signal for the LHRH surge, and (2) increase the responsiveness of the pituitary gonadotropes to LHRH (Figure 15). The LH surge reaches a peak when increased concentrations of LHRH in hypophysial portal blood act upon an anterior pituitary gland whose responsiveness has been further augmented by the priming effect of LHRH and by progesterone secreted during the LH surge. The priming effect of LHRH coordinates increasing pituitary responsiveness with increasing concentrations of LHRH in hypophysial portal vessel blood so that both events reach a peak at about the same time. The termination of the LH surge is due mainly to the fall in portal plasma LHRH concentrations (Sarkar et al., 1976; Sherwood et al., 1980) and, to a lesser extent, the decline in pituitary responsiveness to LHRH (Blake, 1976).

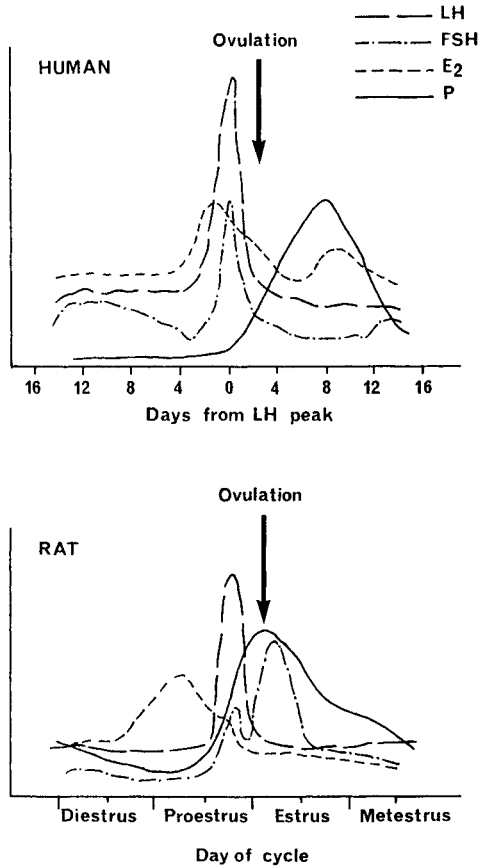

Figure 14. Schematic diagram of the key hormonal changes during the human menstrual cycle and rat estrus cycle. Ovulation is preceded by a surge of luteinizing hormone (LH), which is triggered by a surge of estradiol-17 β (E₂) and accompanied and followed by a surge of progesterone (P). Most of the progesterone is secreted by the ovary in response to LH, but in the rat a small amount of progesterone is secreted by the adrenal gland just before the onset of the LH surge. In the human, the timing and magnitude of the FSH surge are less consistent than that of the LH surge, and in the rat the major peak of the FSH surge occurs on the morning of estrus (after or about the time of ovulation).

Generation of the LHRH Surge

The Ovarian Signal

The hormonal events surrounding the first (pubertal) surge of LH in the rat constitute important evidence for the view that the E_2 surge is the first event in the cascade (Figure 15). As in the adult, the first pubertal LH surge is due to a surge of LHRH and a marked increase in pituitary responsiveness to LHRH (Sarkar and Fink, 1979a). Both are preceded by an increase in plasma E_2 concentrations which occurs in the absence of any major change in the mean plasma gonadotropin concentrations (Meijs-Roelofs et al., 1975), but which may depend on pulsatile LH release (Mackinnon et al., 1978). The brain-pituitary mechanism for the positive

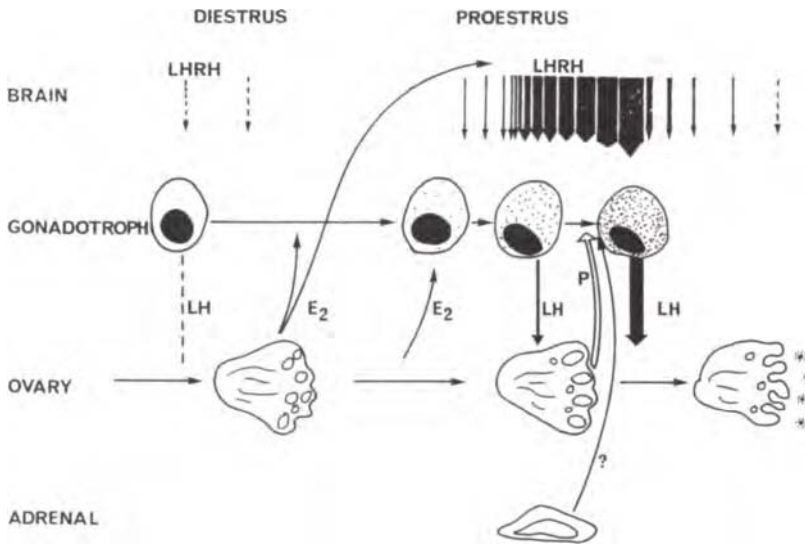

Figure 15. Schematic diagram which shows the cascade of events which generates the spontaneous ovulatory LH surge in the rat. The increase in plasma concentrations of estradiol- 17β (E_2 : the ovarian signal) increases the responsiveness of the pituitary gonadotropes (increased stippling) to LHRH and also triggers the surge of LHRH. Pituitary responsiveness to LHRH is further increased by progesterone (P) secreted from the ovary in response to the LH released during the early part of the LH surge and by the priming effect of LHRH, the unique capacity of the decapeptide to increase pituitary responsiveness to itself. The priming effect of LHRH coordinates the surges of LHRH with increasing pituitary responsiveness so that the two events reach a peak at the same time. The conditions are thereby made optimal for a massive surge of LH. This cascade, which represents a form of positive feedback, is terminated by destruction of a major component of the system in the form of the rupture of the ovarian follicles (ovulation).

gonadotropin response to E_2 becomes fully functional about 20 days before the first LH surge (Mackinnon et al., 1978). Therefore, the time of occurrence of the first LH surge depends on the capacity of the ovary to secrete E_2 in a cyclical manner (Ojeda and Urbanski, 1987) rather than on maturation of the neuroendocrine brain.

The Neural Signal

The LHRH neurons of the hypothalamus constitute the final common pathway for the neural signal. The latter occurs daily in the rat, but is only expressed as a surge of LHRH in the presence of high plasma concentrations of E_2 (Everett and Sawyer, 1950; Legan and Karsch, 1975; Sarkar et al., 1976; Henderson et al., 1977a; Sarkar and Fink, 1979a; Sherwood et al., 1980; Ching, 1982). A similar mechanism operates in the rhesus monkey (Neill et al., 1977). Progesterone, depending upon dosage, has either no effect or an inhibitory effect on LHRH release (Sarkar and Fink, 1979b), which suggests that the facilitatory effect of progesterone on the LH surge is exerted mainly by increasing pituitary responsiveness to LHRH.

Hypothalamic deafferentation studies have shown that the area crucial for the LHRH surge is the anterior hypothalamus (see Figure 12) which encompasses the medial preoptic area and SCN and contains the cell bodies of many hypothalamic LHRH neurons (Barraclough, 1966; Raisman and Brown-Grant, 1977; Rethelyi et al., 1981; Kelly et al., 1982; Kozlowski and Les Dees, 1984; Silverman, 1987). Regular cyclical activity of the LHRH surge generator appears to depend on the integrity of the major inputs to the anterior hypothalamus from the midbrain and forebrain limbic systems (Nauta, 1963; Raisman, 1966). The daily neural signal for LHRH release is probably generated by the SCN, since lesions of the SCN and their 5-HT afferents from the raphe nuclei block ovulation (Brown-Grant and Raisman, 1977; Maxwell and Fink, 1988). Daily surges of LH can be induced experimentally by constant exposure of female rats to high levels of E_2 (Watts et al., 1989) (see Figure 16). Lesion of a major projection field of the SCN, the subparaventricular zone of the hypothalamus, reduces significantly the magnitude of the daily surges of LH and prolactin in ovariectomized rats treated with E_2 (Watts et al., 1989). These data suggest that the SCN affects the diurnal release of LH and prolactin by pathways involving at least one and possibly more synapses. However, direct circadian control of LHRH neurons by the SCN may also occur since vasoactive intestinal peptide (VIP) is the major transmitter in SCN efferents, and VIP-containing nerve terminals are present on LHRH neurons (van der Beek et al., 1994).

The hippocampus and amygdala, the anatomically most prominent components of the forebrain limbic system, have long been thought to play a major role in controlling the ovulatory surge of LH. However, rats in which the major connections between hippocampus and amygdala and the hypothalamus have been severed continue to show regular estrous cycles, and electrical stimulation of the hippocam-

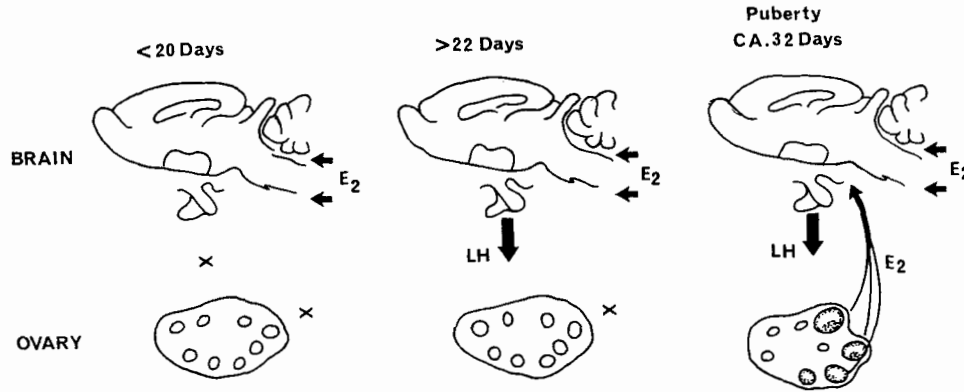

Figure 16. Schematic diagram to show the ontogeny of the positive-feedback system leading to the first pubertal surge of luteinizing hormone (LH) in the rat. Before the 20th postnatal day, the hypothalamic-pituitary system is not responsive to estradiol-17 β (E₂). After 22 days of life the hypothalamic-pituitary system becomes responsive to the stimulating effects of E₂, but the enzymatic mechanisms necessary to produce estrogen have not yet developed in the ovary. With time and under the influence of "basal" (probably pulsatile) gonadotropin levels, the first batch of ovarian follicles grow and at the same time develop the capacity to synthesize and secrete E₂ in the form of a surge which then triggers the surge of LH. A similar mechanism probably operates in the human but takes about 12 years to develop. In humans (and nonhuman primates), the hypothalamic-pituitary system is active during the first 4 years of life and then becomes refractory before the developmental changes that lead to puberty. [From Fink (1988a) with permission].

pus and amygdala has no significant effect on LHRH release into hypophysial portal blood (Chiappa et al., 1977).

The potent effects of visual and auditory stimuli on ovulation could be mediated by the multisynaptic pathways that link the neocortex of the brain with the hypothalamus (Jones and Powell, 1970). Light could also affect ovulation by a direct pathway that links the retina with the SCN, as well as by another multisynaptic pathway, which involves the retina, the SCN, the superior cervical ganglia, and the pineal gland. The latter pathway is especially important in species such as the hamster, vole, sheep, and wallaby in which the reproductive cycle is under photoperiodic control (Klein, 1978; Moore, 1978; Reiter, 1981; Renfree, 1981; Versi et al., 1983; Karsch et al., 1984; Bittman et al., 1985). Although the role of the retina–SCN–pineal pathway in the control of the reproductive cycle in seasonal breeders is supported by robust data, the precise mechanism remains an enigma in that the site and mechanism of action of melatonin, the major secretory product of the pineal gland, is not established. Similarly, although implicated in the control of the onset of puberty, the precise role of the pineal and melatonin in delaying puberty onset remains to be determined (Waldhauser et al., 1993).

Estradiol in its positive feedback mode for LHRH release also stimulates the synthesis of LHRH mRNA (Rosie et al., 1990). This increased synthesis of LHRH mRNA correlates with increased hypothalamic content of LHRH which can be detected in the adult (Chiappa and Fink, 1977), but is seen much more clearly during the first (pubertal) proestrus (Sarkar and Fink, 1979b).

Site of Action of E₂ for Stimulating LHRH Biosynthesis and Release

Immunoidentified LHRH neurons contain few if any nuclear receptors for E₂ (Shivers et al., 1983) suggesting that E₂ must exert its action on LHRH neurons by way of interneurons. Estrogen takes about 26 to 28 h to trigger the surges of LHRH and LH (Fink, 1979a; Fink, 1979b; Sarkar and Fink, 1979b) which is more than sufficient time for RNA, protein synthesis, and even structural changes to occur in neurons and anterior pituitary cells. This relatively long latent period suggests that the action of E₂ may be mediated by complex neural circuits and/or complex transcriptional mechanisms. Pharmacological and *in situ* hybridization data show that at least two potent stimulatory and two disinhibitory mechanisms could mediate the positive feedback action of E₂ on LHRH mRNA synthesis and LHRH release.

Stimulatory mechanisms. α_1 -Adrenoreceptor antagonists block E₂ stimulation of LHRH and LH release (Sarkar and Fink, 1981; Dow et al., 1994) and also reduce the total number of LHRH mRNA containing cells in the preoptic area, suggesting that an α_1 -adrenoreceptor mechanism mediates E₂ stimulation of LHRH mRNA synthesis, as well as release (Weesner et al., 1992; Weesner et al., 1993; Rosie et al., 1994). α_1 -Adrenoreceptors also prevent the E₂-induced decrease of

POMC mRNA expression in the arcuate nucleus (Rosie et al., 1994). Thus, stimulation by E_2 of an α_1 -adrenoreceptor mechanism could exert a direct effect on LHRH neurons and, for reasons outlined below, could also stimulate LHRH synthesis and release by the inhibition of arcuate POMC neurons which may inhibit LHRH neurons.

The second stimulatory mechanism involves 5-HT which stimulates LH release under conditions of high levels of E_2 (Weiner et al., 1988). *In situ* hybridization studies showed that E_2 in its positive feedback mode induces a massive increase in 5-HT₂ receptor mRNA in the dorsal raphe nucleus (Sumner and Fink, 1993), and 5-HT_{2A} receptor antagonists, ritanserin, ketanserin, and the highly selective RP62203, blocked the spontaneous LH surge and the E_2 -induced LHRH surge (Dow et al., 1994; Fink et al., 1996). These findings suggest that the 5-HT_{2A} receptor plays a pivotal role in the E_2 -induced LH and LHRH surge.

Disinhibitory mechanisms. The disinhibitory hypothesis proposes the existence of an opioid and dopaminergic "clamp" whereby arcuate POMC and/or dopaminergic (DA) neurons inhibit LHRH neurons (Fink, 1988b). Both DA and POMC neurons are known to project to the external layer of the median eminence where their terminals are juxtaposed to those of LHRH neurons. Proopiomelanocortin (β -endorphin) terminals also represent about 9% of all synaptic input to LHRH neurons (Chen et al., 1989). In the presence of low levels of E_2 , arcuate POMC and DA neurons inhibit LHRH biosynthesis and release; when plasma E_2 concentrations rise to surge levels, POMC and DA neurons are switched off and, as a consequence, LHRH neurons are disinhibited, leading to LHRH biosynthesis and release. Since DA is known to inhibit prolactin release, the inhibition of DA neurons by E_2 could also result in the spontaneous preovulatory prolactin surge.

This hypothesis receives support from our *in situ* hybridization data which showed that E_2 in its positive feedback mode significantly reduced POMC mRNA levels in the anterior region of the arcuate nucleus (Rosie et al., 1994), precisely where Wise et al. (1990) also found a significant reduction in POMC mRNA on the afternoon/evening of proestrus. The fact that E_2 can significantly reduce POMC transcription within 60 min (Roberts et al., 1986) suggests that the reduced levels of POMC mRNA are due to inhibition of POMC gene transcription rather than to increased POMC mRNA degradation.

The hypothesis that the E_2 -induced synthesis and release of LHRH is mediated by two stimulatory, an α_1 -adrenoreceptor and a 5-HT_{2A} receptor, and two disinhibitory mechanisms, DA and POMC/ β -endorphin, is probably grossly oversimplified in that other neurotransmitters/neuromodulators (e.g. excitatory amino acids, GABA, galanin, neuropeptide Y) may be involved in the control of LHRH biosynthesis and release (e.g. Besecke et al., 1994; Rossmannith et al., 1994; Woller and Terasawa, 1994).

It is, of course, possible that the effects of α_1 -adrenergic blockade on LHRH mRNA and POMC mRNA expressing cells are functionally unrelated. However,

these findings provide further support for the view that endogenous opioids play a key role in controlling the biosynthesis and release of LHRH (Kalra and Kalra, 1984; Fink, 1988a; Rosie et al., 1990), and that several different pathways, possibly multisynaptic, may be involved in E_2 stimulation of LHRH biosynthesis and release (Kalra and Kalra, 1984; Fink, 1988a). The involvement of α_1 -adrenoreceptor and 5-HT_{2A} receptor mechanisms in the control of LHRH biosynthesis and release is supported by immunocytochemical data. Thus, for example: (1) there is a dense concentration of α_1 -adrenergic receptors in the medial hypothalamus (Young and Kuhar, 1980), and (2) double immunostaining for LHRH and either dopamine- β -hydroxylase (DBH) (for adrenergic neurons) or 5-HT showed that there is a close proximity between LHRH cell bodies and DBH and 5-HT-containing nerve terminals and between LHRH and 5-HT nerve fibers (Jennes et al., 1982). Nevertheless, interneurons are likely to be involved because ultrastructural and lesion studies suggest that LHRH neurons are innervated by POMC and dopaminergic but not noradrenergic neurons (Leranth et al., 1988a, b), and our double *in situ* hybridization studies show that LHRH neurons do not express 5-HT_{2A} receptors (Grahame et al., 1994). Noradrenergic neurons could conceivably exert their effects on LHRH neurons by GABA in addition to POMC neurons since glutamic acid decarboxylase (GAD) containing neurons receive projections from putative noradrenergic fibers and project to LHRH neurons (Leranth et al., 1988b). Data obtained from push-pull cannula (Jarry et al., 1988) or intracerebral infusion (Herbison and Dyer, 1991) techniques suggest that E_2 -induced inhibition of GABA release may result in disinhibition of LHRH neurons. Whether this is due to a direct action of E_2 on GABA neurons or E_2 -induced noradrenergic inhibition of GABA neurons (Leranth et al., 1988b), or both, is not clear.

The inferences drawn from the *in situ* hybridization studies assume that changes in peptide mRNA levels are always reflected by changes, in the same direction, in peptide release. This is certainly the case for LHRH (Rosie et al., 1990), and also seems likely for POMC/ β -endorphin. As assessed by the measurement of β -endorphin release into hypophysial portal vessel blood, which presumably reflects β -endorphin release from nerve terminals in the median eminence, the data of Sarkar and Yen (1985) suggest that, in the rat, LHRH and β -endorphin release are inversely related, consistent with the notion that decreased β -endorphin release permits the surge release of LHRH. But this finding was not confirmed by other studies in the rat (Sheward et al., 1991) or rhesus monkey (Wardlaw et al., 1982; Wehrenberg et al., 1982), although our studies in the rat did show a decline in β -endorphin release during the afternoon of proestrus (Sheward et al., 1991). The latter is correlated with a significant decrease in the tissue concentrations of β -endorphin in the MPOA and arcuate nucleus (Kerdelhué et al., 1988), and suggests that "overflow" of β -endorphin into hypophysial portal vessel blood does reflect the pattern of β -endorphin release at synapses on LHRH cell bodies or at axo-axonal contacts in the median eminence.

Corroborative evidence for the role of disinhibition in E_2 stimulation of LHRH release comes from metabolic studies which show that [^{14}C]2-deoxyglucose utilization is markedly reduced in the arcuate nucleus, median eminence, and preoptic area around the time of the spontaneous ovulatory LH surge (McQueen and Fink, 1988).

The physiology of E_2 positive feedback on the LHRH biosynthesis and release is thus reasonably well-delineated. What remains is the Herculean, but fascinating, task of unravelling: (1) the neural circuitry of the LHRH surge generator, and (2) molecular mechanisms by which E_2 controls gene transcription in the interneurons that modulate the LHRH neurons. The inhibitory and facilitatory actions of E_2 on LHRH release are quite distinct. The inhibitory action is fast, may not necessarily involve a genomic mechanism, and occurs with low levels of E_2 . The facilitatory action takes a long time—at least 24 h, requires high levels of E_2 , is associated with LHRH synthesis, and involves the expression of a daily neural signal for LH release.

Electrophysiological Correlates of E_2 Positive Feedback on the Hypothalamus

In spite of more than two decades of study, no clear picture has emerged about the electrophysiological correlates of the action of steroids in triggering the LHRH surge. In the rat, E_2 enhances spontaneous or evoked firing of hypothalamic units (Cross, 1973; Sherwood et al., 1976; Hayward, 1977), and on the afternoon of proestrus an increase in single-unit activity has been reported in various hypothalamic nuclei (Cross, 1973; Hayward, 1977). As assessed by the release of LHRH into hypophysial portal vessel blood, E_2 also increases the responsiveness of the preoptic–LHRH release system to electrical stimulation (Fink and Jamieson, 1976; Sherwood et al., 1976). In ovariectomized rhesus monkeys primed with E_2 , progesterone increased the firing rate of units in the ventral hypothalamus and concomitantly induced a surge of LH (Yeoman and Terasawa, 1984). Yeoman and Terasawa speculate that the increased firing occurred in “interneurons” and that this is consistent with early studies in the rat (Dyer, 1973) which showed that increased firing in the preoptic–anterior hypothalamic region on the afternoon of proestrus occurred only in units that were not antidromically identified to project to the medial basal hypothalamus. Estrogen also increases the firing of: (1) units which are within the hypothalamus, but which may be concerned with mating behavior rather than the LH surge (Pfaff, 1986); and (2) units in other areas remote from the hypothalamus, such as the neostriatum (Tansey et al., 1983).

These apparently disparate actions of E_2 could be linked in that it is conceivable that the action of E_2 on interneurons that modulate the activity of LHRH neurons, neurons of the ventromedial nucleus that stimulate lordosis (female mating behavior; Pfaff, 1980), and neurons of the neostriatum involved in motor behavior could underlie the proestrus surge of LHRH, mating, and increased motor activity, all of which occur in the 12 h between the afternoon of proestrus and the early morning

of estrus. In all three systems elevated plasma concentrations of E_2 take about 26–28 h to exert their effect, a latency which would be more than sufficient for mRNA and protein synthesis and even structural changes to occur in neurons. It is most unlikely that the latent period reflects the time taken for direct effects of steroids on the electrophysiological properties of neuronal membranes, although such changes may occur. Rather, the latency suggests that the action of E_2 involves activation of its receptor and other transcription factors which by way of genomic mechanisms exert effects on the synthesis and/or function of ion channels, receptors, enzymes, and/or neuropeptide precursors such as POMC. However, sophisticated and meaningful interpretation of the effects of E_2 on LHRH release will not be possible until the circuitry of the LHRH surge generator has been established.

Changes in Pituitary Responsiveness to LH-Releasing Hormone

The magnitude of the spontaneous preovulatory LHRH surge is far too small to produce the ovulatory surge of LH without the massive increase in pituitary responsiveness to LHRH which precedes ovulation in women, monkeys, sheep, and rats (Fink, 1979a, b; Fink et al., 1982a; Nett et al., 1984) (Figure 17). In women, as in the rat, the increase occurs in two phases: gradually during the two days before the midcycle LH surge, and then abruptly (10-fold) on the day of the surge (Yen et al., 1975), resulting in an overall increase of about 20- to 50-fold between the early follicular and the ovulatory phases in women and diestrus and proestrus in rats. The preovulatory increase in the plasma E_2 concentration is essential for initiating and maintaining the increase in pituitary responsiveness to LHRH. Estradiol, at its peak physiological concentration, takes about 8 to 12 h to enhance responsiveness; in the first few hours the effect of E_2 is inhibitory (Cooper et al., 1974; Vilchez-Martinez et al., 1974; Henderson et al., 1977b). The abrupt rise in pituitary responsiveness at the time of the LH surge is caused by the self-priming effect of LHRH, the capacity of LHRH to increase (by direct action) the responsiveness of the gonadotropes to itself (Aiyer et al., 1974a; Wang et al., 1976; Fink and Pickering, 1980).

Pituitary responsiveness is also increased by progesterone released in response to early LH stimulation of the ovary (Aiyer et al., 1974a; Fink and Henderson, 1977). Plasma progesterone concentrations increase before the beginning of the LH surge in the rat. However, although important for ensuring full sexual receptivity, this early increase in plasma progesterone, secreted by the adrenal gland, is not essential for the occurrence of the LH surge (Feder et al., 1971). Progesterone is more potent than any of its major metabolites in facilitating pituitary responsiveness. Androgens reduce the LH response to LHRH, but have either no, or only a slight, facilitatory effect on the FSH response to LHRH (Drouin and Labrie, 1976; Fink and Henderson, 1977). Progesterone also augments the effect of E_2 in women (Yen et al., 1975; Wang et al., 1976), but because of the timing of increased

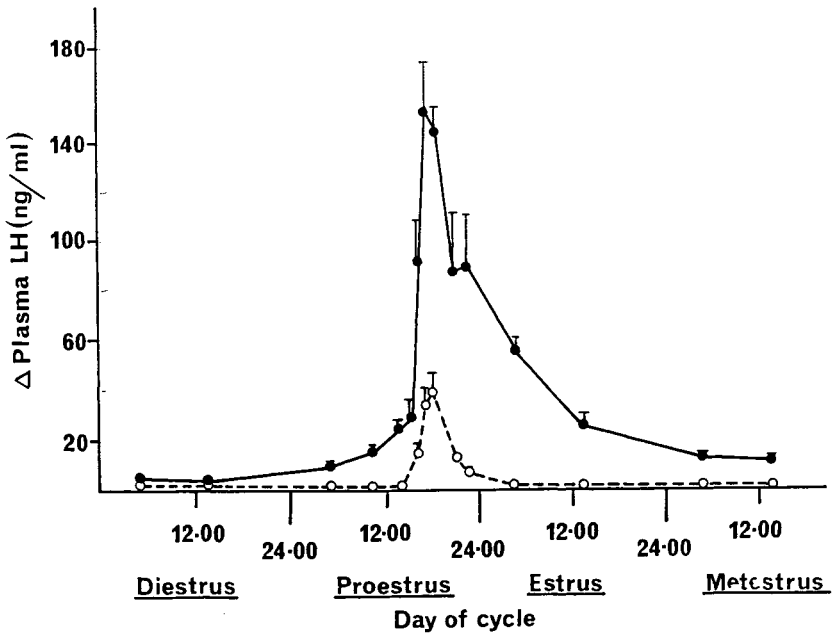

Figure 17. Changes in pituitary responsiveness to LHRH during the estrus cycle of the rat. Note the exponential increase on the afternoon of proestrus. The figure shows mean (\pm SEM) preinjection concentrations (*dashed line*) and mean maximal increments (*continuous line*) plasma LH concentrations (ng NIH-LH-S13/mL) in animals anesthetized with sodium pentobarbitone 30–60 min before the intravenous injection of 50 ng LHRH/100 g body weight at different stages of estrus cycle. [Reproduced from Aiyer et al. (1974a) with the permission of the *Journal of Endocrinology*].

progesterone secretion it is not certain whether this plays a major role in the midcycle LH surge (Fink, 1977).

The mechanism by which steroids increase pituitary responsiveness to LHRH is not known. During the 24 h before the LH surge there is an increase in pituitary LH content, compatible with the possibility that E_2 may stimulate LH synthesis and thereby increase the amount of LH available for release. However, steroids also alter the sensitivity of the gonadotropes, as shown by the marked increase in the response to LHRH which occurs in the absence of a significant change in pituitary LH content in long-term ovariectomized rats treated with E_2 and progesterone (Fink, 1979a).

The nuclear and total concentrations of E_2 -receptor complexes in the pituitary are greater at proestrus than at other times of the cycle, and progesterone receptors in the pituitary are E_2 -dependent. Studies using dispersed rat pituitary cells, or rats in which the pituitary stalk has been cut, show that E_2 and progesterone can facilitate pituitary responsiveness by a direct action on the gonadotropes (Fink, 1979a).

Estradiol also stimulates gonadotropin release in rhesus monkeys bearing lesions of the arcuate nuclei and infused intermittently with LHRH (Knobil, 1974). However, in addition to a pituitary site of action, the following data suggest that at least part of the action of E_2 in increasing pituitary responsiveness to LHRH may be mediated by the self-priming effect of LHRH: (1) E_2 stimulates LHRH release in the rat (Sarkar and Fink, 1979b), sheep (Caraty et al., 1989; Moenter et al., 1990), and rhesus monkey (Neill et al., 1977); (2) the fall in portal LHRH concentrations that occurs after ovariectomy on diestrus can be prevented by E_2 (Speight et al., 1981); (3) sodium pentobarbitone, which blocks LHRH release, also blocks the facilitatory action of E_2 on pituitary responsiveness to LHRH (Fink, 1979a); and (4) the full effect of E_2 requires an intact pituitary stalk (Fink and Henderson, 1977).

There is a marked sex difference in the effect of E_2 on the LH response to LHRH (Turgeon and Barraclough, 1974; Fink and Henderson, 1977). This was at first puzzling since there is good evidence that in the rat sexual differentiation of the HPG system is due to changes predominantly in the brain (Harris, 1970). However, if at least part of the action of E_2 in increasing pituitary responsiveness to LHRH requires normal function of the hypothalamic LHRH system, this could explain the marked sex difference in the effect of E_2 on pituitary responsiveness to LHRH.

The Self-Priming Effect of LHRH (A Unique Servomechanism)

Two observations raised the possibility that LHRH increases the responsiveness of the pituitary gland to itself, the priming effect of LHRH (Aiyer et al., 1974a). First, studies in humans and the rat (Aiyer et al., 1974a, b) showed that there was a positive correlation between the basal plasma concentrations of LH and the magnitude of LH response to LHRH. Second, the magnitude of the LH response to exogenous LHRH in proestrus rats could be reduced significantly by injecting sodium pentobarbitone, which blocks LHRH release (Aiyer et al., 1974b; Sarkar et al., 1976; Sherwood et al., 1980). Experimental proof for the existence of the self-priming effect of LHRH came from our study which showed that the magnitude of the LH response to the second of two injections of LHRH in proestrus rats was significantly greater than that to the first LHRH injection (Figure 18). While E_2 enhances the magnitude of the priming effect (Figure 19), steroids do not mediate the effect (Aiyer et al., 1974a; Meidan et al., 1981). Indeed the magnitude of the priming effect was increased by 64% in acutely ovariectomized compared with sham-ovariectomized animals, suggesting the existence of an ovarian factor which inhibits LHRH self-priming (Aiyer et al., 1974a). The magnitude of the self-priming effect depends also on the LHRH pulse frequency, increasing to reach a maximum when the interval between pulses is 60 min and then declining quite dramatically with increase in interval between pulses (Figure 18) (Aiyer et al., 1974a). This finding shows that the intracellular events that cause priming are transient involving "cellular memory," and is consistent with other data that show the optimal frequency of pulses of LHRH for LH release in the human, monkey, and rat is about

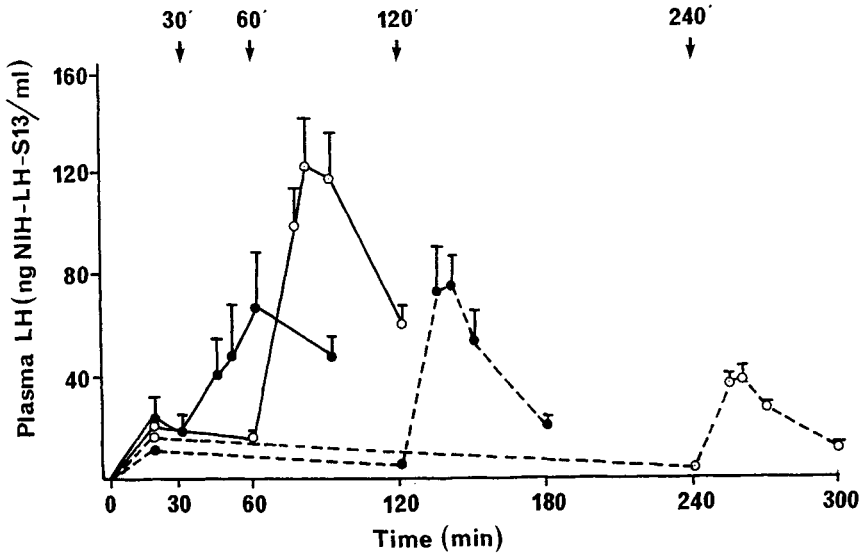

Figure 18. The priming effect of LHRH in the rat. Mean (\pm SEM) plasma LH concentrations (ng NIH-LH-S13/mL) after two successive intravenous injections of 50 ng LHRH/100 g body weight. The first dose of LHRH was injected 30–60 min after the administration of sodium pentobarbitone at 13.30 h proestrus; the second dose of LHRH was injected either 60, 120, or 240 min after the first. Note that the LH response to the second of two LHRH injections was always significantly greater than that to the first and that the response was maximal when the two injections of LHRH were separated by 60 min. [From Aiyer et al. (1974a) with permission of the *Journal of Endocrinology*].

one per hour (Yen et al., 1972; Aiyer et al., 1974a; Knobil, 1980). The latter also underscores the importance of temporal coding of pulsatile LHRH release (Herbert, 1993).

A point that is often overlooked is that low levels of LHRH infused continuously or in the form of pulses, too small by themselves to effect LH release, can also prime the anterior pituitary gland and result in a massive surge of LH (Figure 20) (Fink et al., 1976; Fink, 1976). This is important for several reasons. First, it explains how E_2 -induced increase in pituitary responsiveness could be due in part to LHRH self-priming (see above). Second, it demonstrates that in the rat, as in the rhesus monkey, the surge of LH is not dependent upon a massive surge of LHRH; a series of small LHRH pulses can also produce an ovulatory surge of LH by way of the self-priming effect of LHRH. Third, it shows how pulses of LHRH can induce a surge of LH in E_2 -treated rhesus monkeys in which the hypothalamus or the pituitary gland have been disconnected (Knobil, 1980). The fact that this can be shown experimentally does not mean that an LHRH surge does not normally occur in this species. The probable physiological significance of the LHRH surge in the

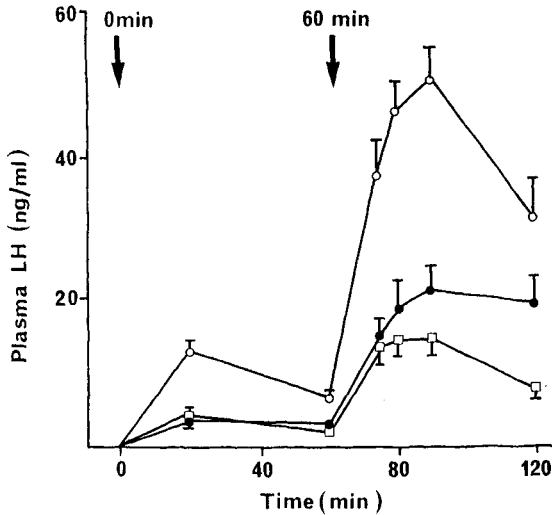

Figure 19. Potentiation by estrogen of both the releasing action and priming effect of LHRH. Mean (\pm SEM) plasma luteinizing hormone (LH) concentrations (ng NIH-LH-S13/mL) after two successive iv injections of 50 ng/100 g body weight, 60 min apart (arrows). The animals were injected subcutaneously with 0.2 mL oil (\bullet), 10 μ g estradiol benzoate (\circ), or 2.5 mg progesterone (\square) at 10.00 h of metoestrus. The first dose of LHRH was injected 30–60 min after the administration of sodium pentobarbitone at 13.30 h of the next day, dioestrus. [From Aiyer et al. (1974b) with the permission of the *Journal of Endocrinology*].

rat is that it ensures that the LH surge occurs at a precise time in relationship to the light–dark cycle of the environment and sleep–wake cycle of the animal.

So far, no other neuropeptide or non-peptide transmitter has been shown to exert a priming effect on pituitary or other types of effector cells, although mechanisms in the nervous system, such as long-term potentiation, resemble the priming effect. It is not clear why LHRH has this apparently unique property, but perhaps it is related to the fact that apart from the uterine contraction–oxytocin release system that operates during parturition the LH surge is the only positive feedback mechanism in endocrine systems. The biological economy of the self-priming effect of LHRH is remarkable in that it amplifies by an order of magnitude the efficacy of the LHRH/LH surge mechanism, enabling a very small amount of LHRH to induce a massive release of LH.

The cellular mechanism of the priming effect of LHRH. There are major differences between the mechanisms of the self-priming and the releasing action of LHRH (Pickering and Fink, 1976; Fink, 1979a; Waring and Turgeon, 1980; Turgeon and Waring, 1981; Turgeon and Waring, 1994). Briefly, in contrast to the

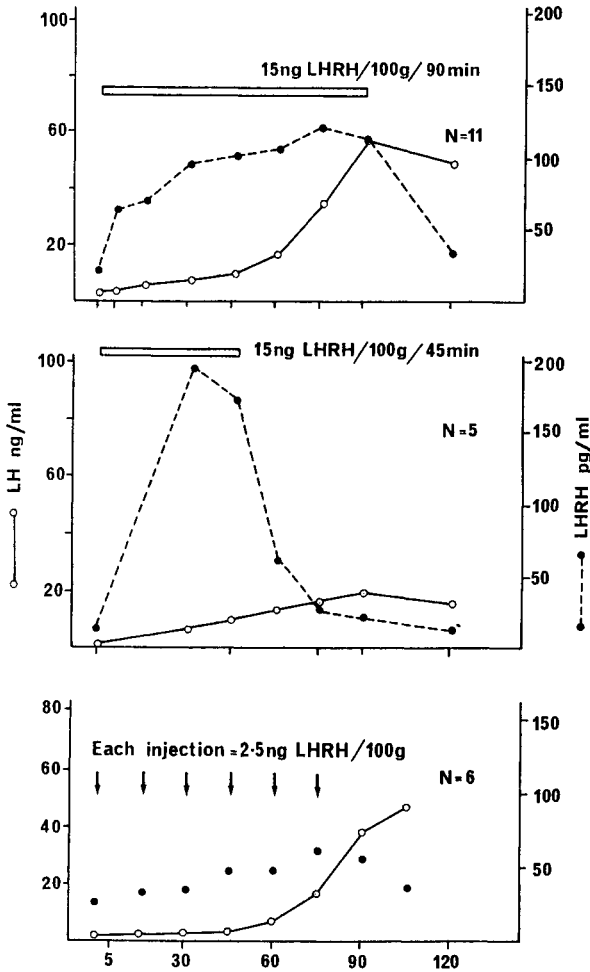

Figure 20. Demonstration of the fact that exposure of the rat pituitary gland (*in vivo*) to small pulses of LHRH or to continuous infusion of low concentrations of LHRH results in a surge of LH which is similar in magnitude to the spontaneous ovulatory surge of LH. Mean plasma LH concentrations are shown before and during either continuous intravenous infusions (*top panel*) or multiple small intravenous injections of LHRH (*bottom panel*). Note that the effect is time dependent in that infusion of the same total dose of LHRH (*middle panel*) for 45 min rather than 90 min failed to produce a surge of LH. In the bottom panel the dots represent LHRH concentrations in plasma measured before, and 15 min after, each LHRH injection. The pulses of LHRH were too small by themselves to release LH. [From Fink et al., 1976 and Fink, 1976 with permission].

releasing action of LHRH, the priming effect of LHRH: (1) cannot be mimicked by K^+ depolarization or Ca^{2+} ionophores; (2) is independent of normal extracellular Ca^{2+} concentrations; (3) involves an elongation and change in orientation of the microfilaments; (4) involves the movement of secretory granules towards the plasma membrane of immunoidentified gonadotropes ("margination"; see below); (5) involves potentiation of the IP_3 and intracellular Ca^{2+} mechanisms and a novel protein kinase C (PKC) (Johnson et al., 1992; Ison et al., 1993; Simpson et al., 1993); and (6) involves the synthesis of a new protein (Pickering and Fink, 1976; Pickering and Fink, 1979a; Curtis et al., 1985; Morris et al., 1986; Fink, 1988b; Mitchell et al., 1988).

The LHRH-induced "priming protein" has a relative molecular mass (70 kDa; Curtis et al., 1985) and similar electrophoretic properties to that of an E_2 -induced protein in the ventromedial nucleus of the hypothalamus which is associated with lordosis behavior in the female rat (Mobbs et al., 1988). The amino acid residue sequence of the amino terminals of the acidic and basic forms of the LHRH and E_2 -induced 70 kDa proteins (termed hormone-induced protein — HIP 70) are identical to one another and a protein also found in uterus (Mobbs et al., 1990a; Mobbs et al., 1990b; Kaplitt et al., 1993). Recent sequence data suggest that HIP 70 is a thiol-dependent reductase (member of the protein disulphide isomerase family), which is likely to have several important functions including a key role as a chaperone that ensures correct protein folding in the endoplasmic reticulum (Oliver et al., 1997; Mobbs et al., 1997). The significance of HIP 70 induction by LHRH and E_2 in the context of its role as a thiol-dependent reductase is currently being investigated.

The LHRH priming effect cannot be attributed to an increase in LHRH receptors because although pulses of LHRH do increase the amount of LHRH receptor mRNA in pituitary cells (Kaiser et al., 1993), the increase over one hour is far too small to play a significant role in LHRH priming. Furthermore, specific studies on priming *in vitro* showed that there is no increase in LHRH binding sites in pituitary slices 60 min after exposure to LHRH (Mitchell et al., 1988).

The cytoskeleton, PKC, and LHRH priming. The LHRH-induced change in orientation and length of the microfilaments in gonadotropes and a significant migration of secretory granules of the gonadotropes to a "marginal" zone close to the plasmalemma (Figure 21) are possibly central to LHRH self-priming in that granules in the marginal zone can easily be released as a consequence of a second exposure to a secretagogue such as K^+ depolarization, Ca^{2+} ionophores, or LHRH (Pickering and Fink, 1979a). This migration of secretory granules, "margination", is presumably due to changes in the contractile elements of the cell and may explain the increase in the readily releasable pool of LH that occurs before and during the spontaneous ovulatory LH surge (Pickering and Fink, 1979b; Lewis et al., 1985; Lewis et al., 1986). There is an important convergence here between the intracellular signaling systems in that the LHRH-induced changes in cytoskeleton could con-

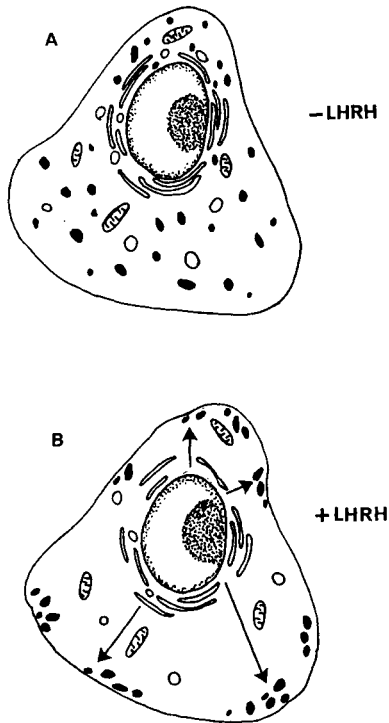

Figure 21. Sketches of pituitary gonadotrophs as seen under the electron microscope illustrating margination. **(A)** Gonadotrope has not been exposed to LHRH. Note that the secretory granules are scattered randomly throughout the cytoplasm. **(B)** Gonadotrope has been exposed to LHRH for 2 h: The granules are fewer in number (presumably because of release) and have moved close to the plasmalemma. The movement of granules to the plasmalemma, which is probably due to the activation of contractile (cytoskeletal) elements of the cell, is the basis for the priming effect of LHRH. That is, LHRH stimulates "margination" of the secretory granules so that much more gonadotropin is available for release when the cells are exposed to another pulse of LHRH or to another secretagogue such as K^+ depolarization or Ca^{2+} ionophore. The mechanism probably involves a novel PKC activated by the LHRH receptor signaling cascade. The PKC in turn induces changes in the cytoskeleton (elongation and change in orientation of the microfilaments), possibly by way of myristoylated alanine-rich C kinase substrate (MARCKS).

ceivably be due to the priming-induced novel PKC (Johnson et al., 1992; Ison et al., 1993; Simpson et al., 1993). Cytoskeletal rearrangement during neurosecretion leukocyte activation and growth-factor dependent mitogenesis is associated with PKC-dependent phosphorylation of myristoylated alanine-rich C kinase substrate (MARCKS) (Aderem, 1992; Hartwig et al., 1992).

The importance of margination of secretory granules in gonadotropes in determining the magnitude of the LH response to LHRH is underscored by testicular feminized (*tfm*) mice which have defective or absent androgen receptors. Ultrastructural studies showed that there is a significant increase in the proportion of secretory granules in the marginal zone of gonadotropes in *tfm* mice and this is associated with a massive LH response (equivalent to a primed response in proestrous female mice) to a single pulse of LHRH (Morris et al., 1986). The most likely explanation of this phenomenon is that the pituitary gonadotropes of the *tfm* are already in a primed state without previous exposure to exogenous LHRH. This is probably due to increased frequency of endogenous LHRH pulses as a consequence of absent or deficient androgen feedback. This probably also explains the increased plasma concentrations of LH and LH pulse frequency in humans with testicular feminization (see below).

Possible common mechanisms in the E₂, progesterone and LHRH self-priming servomechanisms. Full expression of the priming effect of LHRH requires previous exposure of the pituitary to E₂, as does the effect of progesterone. That is, E₂ triggers a cascade of intracellular events which are required for the further exponential increase in pituitary responsiveness generated by LHRH self-priming and progesterone. The precise nature of the intracellular cascade is unknown, but it is possible that some aspects of the mechanism of LHRH self-priming, E₂, and progesterone depend upon common mechanisms. Thus E₂ and LHRH self-priming both induce the same protein (HIP-70, above) and Turgeon and Waring have demonstrated that either LHRH or 8-bromo-cAMP could stimulate the expression of progesterone-responsive elements in transfected anterior pituitary cells cultured in the presence of E₂. This effect was suppressed by the progesterone antagonist RU486 (Turgeon and Waring, 1994), leading, with other studies (Turgeon and Waring, 1992), to the suggestion that the mechanisms of LHRH self-priming and progesterone augmentation converge on the expression of the progesterone receptor.

Summary. In summary, the self-priming effect of LHRH is a powerful servomechanism which potentiates by several fold the pituitary responsiveness to LHRH, and serves to coordinate the increased release of LHRH into hypophysial portal blood with increased pituitary responsiveness to LHRH so that both reach a peak simultaneously. Self-priming involves post-receptor changes which result in a potentiation of the LHRH intracellular signaling cascades and the movement of secretory granules towards the cell membrane (margination). The latter is brought about by changes in the cytoskeleton possibly induced by PKC acting on MARCKS. LHRH self-priming is associated with the synthesis of a new protein, HIP 70, a thiol-dependent reductase. The precise role of HIP 70 in LHRH priming remains to be established, but it may play a key role as a chaperone that ensures correct protein folding in the endoplasmic reticulum.

The Role of LHRH Receptors

The numbers of pituitary LHRH receptors in the female rat increase on the evening of diestrus and are maintained until just before the LH surge on proestrus when they fall (Clayton et al., 1986). This profile parallels the rise and fall of E_2 concentrations in plasma, and recent studies on sheep pituitary cells in culture show that E_2 increases the density of LHRH and the concentrations of LHRH receptor mRNA (Gregg et al., 1991; Wu et al., 1994). Inhibin further increases while progesterone reduces the number of LHRH receptors and the amount of LHRH receptor mRNA in sheep pituitary cells (Gregg et al., 1991; Wu et al., 1994).

Recent studies on the effect of ovariectomy *in vivo* and LHRH pulses *in vitro* show that LHRH pulses increase the amount of LHRH receptor mRNA in rat pituitary cells (Kaiser et al., 1993), a finding which supports the earlier inferences from binding studies after castration (Clayton et al., 1986). Taken together, the data suggest that the E_2 -induced increase in the density of pituitary LHRH receptors is a component of the E_2 -induced cascade which results in increased pituitary responsiveness to LHRH. However, four facts suggest that this is not the only mechanism involved. First, the density of LHRH receptors decreases during the LH surge at the time of the exponential increase in pituitary responsiveness. Second, LHRH self-priming is not dependent on changes in the density of LHRH receptors. Third, progesterone which is a potent enhancer of pituitary responsiveness decreases LHRH receptor density. Fourth, the changes in pituitary responsiveness during the estrous cycle, as assessed by the amount of LH released, can be elicited in dispersed pituitary cells by K^+ depolarization equally as well as by a pulse of LHRH (Speight and Fink, 1981). Thus, changes in the LHRH receptor signaling mechanism, in the amount of LH available for release and in the "release" apparatus itself, are as or more important than receptor number in determining the responsiveness of the anterior pituitary gland to LHRH.

The Apparent Paradox of Negative-Positive Feedback of Estradiol-17 β and Progesterone

During most of the estrous and the menstrual cycle, low plasma concentrations of E_2 and high plasma concentrations of progesterone inhibit gonadotropin secretion by way of the well-known negative feedback system. Whether E_2 and progesterone inhibit or stimulate gonadotropin output depends upon the duration, timing, and level of exposure to the steroid (Fink, 1979b). Thus, progesterone will stimulate LH release only when acting on a hypothalamic-pituitary system which has been exposed for many hours to elevated plasma concentrations of E_2 . In the rat, the switch from an inhibitory to a facilitatory action of progesterone occurs relatively precisely during the early hours of proestrus, when anti-estrogens also cease to be effective in blocking ovulation (Aiyer and Fink, 1974). During most of the cycle, plasma E_2 concentrations are low. In the monkey an LH surge will occur only if E_2

concentrations are maintained at about 200–400 pg/mL plasma for at least 36 h. Basal concentrations, or increments of less than 100 pg/mL, or of a duration shorter than 36 h, reduce LH output (Knobil, 1974). The magnitude of the plasma E_2 concentrations and the duration of exposure at which a switch from an inhibitory to a facilitatory effect occurs in the human is similar to that in the monkey. In the rat, sheep, and human, progesterone and E_2 act synergistically to inhibit gonadotropin release. Thus, in the presence of relatively high plasma progesterone concentrations, basal or elevated concentrations of E_2 will inhibit gonadotropin output. Progesterone by itself has little effect, possibly because the abundance of progesterone receptors in the hypothalamus and pituitary depends upon E_2 .

The Prolactin Surge

The massive proestrus surge of prolactin in the rat which occurs coincidentally with the spontaneous LH surge maintains the function of the corpus luteum for about 1–2 days after ovulation. The role of the much smaller prolactin surge during the midcycle LH surge in the human is not clear. Much less is known about the mechanisms which control the spontaneous prolactin compared with the gonadotropin surge mainly because the nature of the neurohormones that mediate neural control of prolactin secretion remains uncertain (Leong et al., 1983; Fink, 1985; McNeilly, 1987). Dopamine has long been considered the most likely prolactin inhibiting factor, and prolactin release can also be inhibited by GABA. Thyrotropin-releasing hormone (TRH) is one of the most potent prolactin releasing factors when administered exogenously; other peptides which release prolactin when administered exogenously include vasoactive intestinal peptide and the closely related porcine PHI. However, the nature of the endogenous prolactin releasing factor still remains to be determined.

The control of prolactin release is further complicated by the fact that E_2 stimulates prolactin mRNA synthesis and release by a direct action on pituitary cells (Figures 22 and 23). The stimulatory action of E_2 on pituitary prolactin secretion overrides inhibition of prolactin secretion by dopamine and its agonists (de Greef et al., 1985). Thus, the spontaneous proestrous surge of prolactin is conceivably due mainly to the stimulatory action of E_2 on the pituitary gland. However, this simple explanation is unlikely to be correct for two reasons. First, and most importantly, elevated plasma concentrations of E_2 do not necessarily result in a sustained elevation of plasma prolactin concentrations. Rather, elevated plasma E_2 concentrations generate prolactin surges which coincide with E_2 -induced LH surges (Horn and Fink, 1985), suggesting that there is a daily neural signal for prolactin as well as LH release. Second, measurements of hypophysial portal vessel blood show that there are changes in the output of TRH, and possibly dopamine, during E_2 -induced prolactin surges (de Greef et al., 1985). Thus, for example, in intact proestrous rats anesthetized with alphaxalone, the concentrations of TRH in

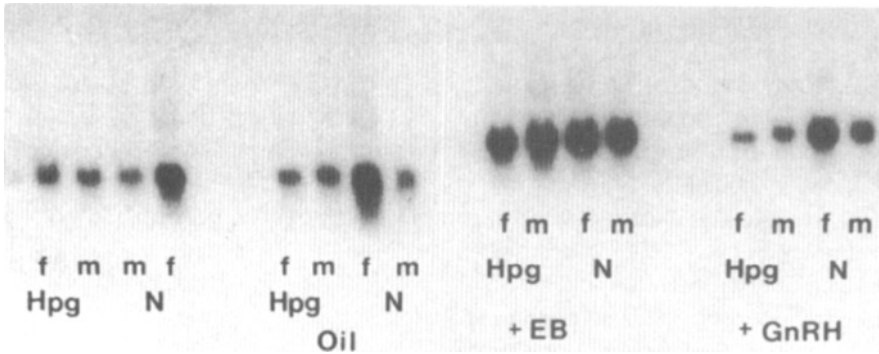

Figure 22. The effect of estrogen on the synthesis of prolactin mRNA. Northern blot analysis of total RNA (10 μ g) from normal (N) and hypogonadal (Hpg) mouse pituitary glands. The hpg mouse is a mutant defective in LHRH (= GnRH). As a result, the gonads remain underdeveloped (hypogonadal) and hence the mutant is exquisitely sensitive to estradiol. Animals were either untreated or injected subcutaneously each day for 10 days with oil, 1 μ g estradiol benzoate (EB), or 1 μ g LHRH. Note that (i) the prolactin mRNA concentration in the normal female (F) mouse is far greater than that in the normal male (M) or in Hpg mice of either sex; (ii) the injection of EB increased prolactin mRNA concentrations in all four types of mouse; and (iii) prolactin mRNA concentrations paralleled the plasma prolactin concentrations (Figure 23). [From Stanley et al. (1986) with the permission of the Endocrine Society].

portal blood during the afternoon–evening were significantly greater (~100% increase) than those during the morning (Fink et al., 1982b).

Proof for a Daily Neural Signal for LH and Prolactin Release

The existence of a daily neural signal for LH [first proposed by Everett and Sawyer (1950)] and prolactin release can be shown in long-term ovariectomized rats treated with high doses of E_2 in which diurnal surges of LH and prolactin occur with peaks in the afternoon of each day (Horn and Fink, 1985). The mechanism of the central nervous control of the daily prolactin surge in this model is not known, although studies of hypophysial portal blood implicate a decrease in dopamine and an increase in TRH release (de Greef et al., 1985). The daily LH surges in the same model are produced by relatively small but significant increases in the release of LHRH into hypophysial portal blood which occur precisely during the afternoon of each day (Fink, 1988a). As in the case of the spontaneous, proestrus surge of LH, the increases in LHRH release into portal blood in long-term ovariectomized rats treated with E_2 are far too small to account for the magnitude of the LH surges. In this steroid model (ovariectomized rats treated with E_2), the responsiveness of the

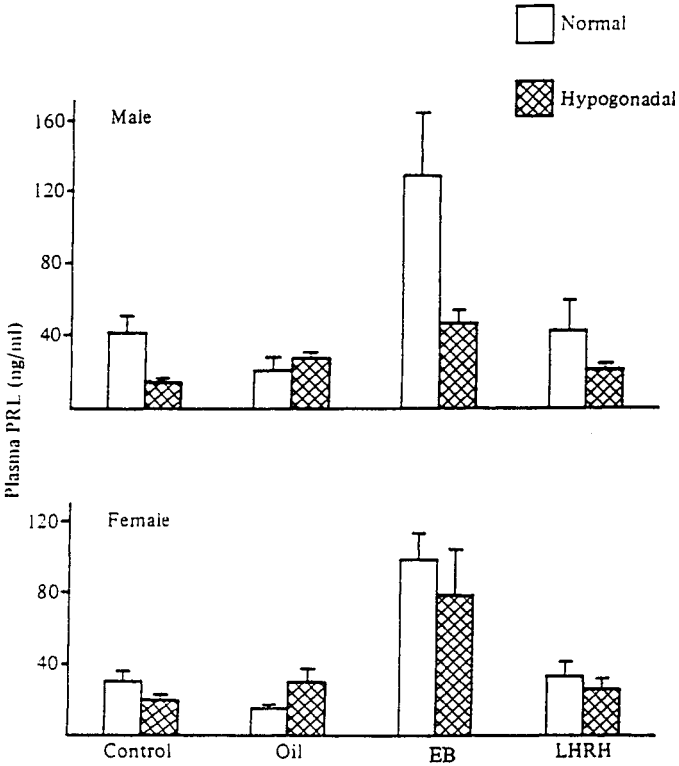

Figure 23. Estrogen stimulation of prolactin (PRL) secretion in normal and hypogonadal mice. The mice were treated as in Figure 22. The values are mean (\pm SEM) plasma prolactin concentrations ($n = 5$ per group). In mice treated with estradiol benzoate (EB), the plasma prolactin concentrations were significantly higher than in the mice treated with oil ($P < 0.01$ to $P < 0.005$). [Data from Stanley et al. (1986)].

pituitary gland to LHRH is more than twofold greater than that at proestrus and more than 100-times greater than that at diestrus (Aiyer et al., 1976; Fink, 1979a).

Hypothetical CNS Model for the Positive Feedback Release of LH and Prolactin

Does the same neural mechanism control the E_2 -induced LH and prolactin surge? Figure 24 shows that E_2 and progesterone could conceivably activate the same surge generator module which then triggers the LH and prolactin surges through “sub-systems” specific for each hormone. The steroids also act at the anterior pituitary gland to increase the gain (i.e. increase pituitary responsiveness) of the system. The latter effect is crucial because the neurohormonal signals are relatively weak and, at least in the case of LH, need to be amplified 20- to 100-fold to produce the surge

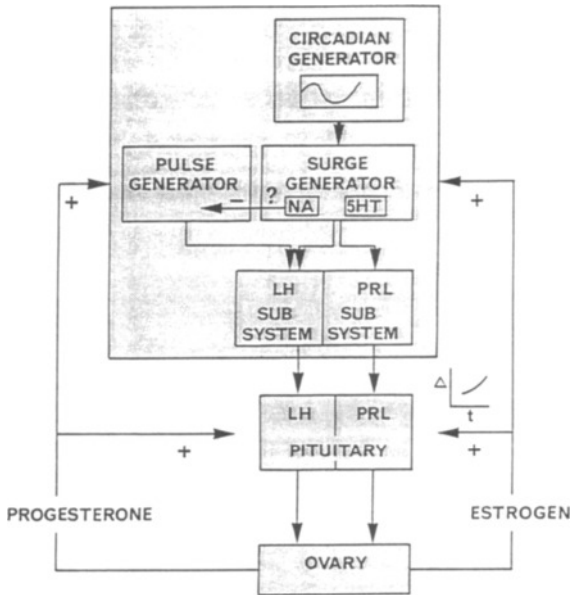

Figure 24. Highly simplified, hypothetical model of the main components in the system which control the gonadotropin and prolactin surges. In the CNS there is a surge generator which drives the LH and prolactin (PRL) control subsystems. The activity of the surge generator is influenced to a large extent by a circadian rhythm generator. The surge generator is probably linked to the pulse generator, and pathways that are involved in generating the surge may switch off the pulse generator (e.g. ascending noradrenergic systems). Estrogen and possibly progesterone trigger the surge generator, but the time at which this generator fires is determined by the activity of the circadian generator. The steroids also increase the responsiveness of the anterior pituitary gland to LHRH. [From Fink (1988a) with permission].

of pituitary hormone. The control system would have to allow for a drive from the circadian oscillator, and possibly a switch that changes the output from the pulsatile mode, which operates during basal secretion of the gonadotropins, to a surge mode. Such a switch may be necessary because although the LH surge could represent a coalescence of enhanced LH pulses, there is evidence that the two modes of secretion are controlled by different central mechanisms; for example, the ascending noradrenergic systems stimulate the LH surge but appear to inhibit pulsatile LH release (Fink et al., 1983; Bergen and Leung, 1987). The LH and prolactin pulse generators may also be linked in that in man and other mammals LH and prolactin pulses appear to be synchronous (McNeilly, 1987). The circadian generator seems to provide a daily signal to the surge generator, but the latter needs to be exposed to high concentrations of E_2 for many hours before this circadian signal is expressed as a surge of LHRH/LH and prolactin.

There is now substantial evidence which implicates serotonergic and noradrenergic neurons in the surge command system. Within the subsystems for LH and prolactin release it is conceivable that at least one mechanism common to both LH and prolactin may operate (Figure 25). That is, E_2 could reduce the activity of the dopaminergic neurons in the arcuate nucleus which would have the effect of disinhibiting LHRH neurons and the prolactotropes resulting in a surge of LH and prolactin. The dopaminergic–LHRH control system has at least one backup—the arcuate β -endorphin secreting neurons which also inhibit LHRH release and which are also inhibited by E_2 .

It must be stressed that this model is highly oversimplified and does not take into account other neuropeptides that may affect gonadotropin and prolactin secretion or other types of interactions between opioid and monoaminergic neurons. The model would also have to account for other modes of hormone release such as the nocturnal prolactin surges which occur in the absence of LH surges in pseudopregnant rats (Jakubowski and Terkel, 1986).

Summary

Estrogen stimulation of the preovulatory gonadotropin and prolactin surge is a remarkable example of a biological positive feedback or servomechanism. The ovulatory surge of LH is triggered by a positive feedback cascade in which E_2 stimulates the synthesis and release of LHRH and at the same time initiates a train

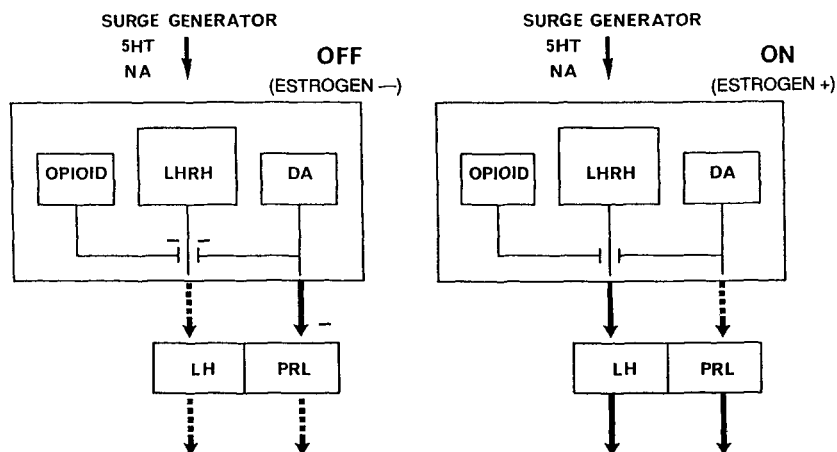

Figure 25. A highly simplified diagram illustrating the hypothesis for how estradiol could, by inhibiting dopamine (DA) neurons, produce both a surge of LH and prolactin (PRL). Note that the DA control of LHRH release has a back-up in the form of the opioid system which may add precision to the LHRH surge. [From Fink (1988a) with permission].

of intracellular events in pituitary cells which leads to a massive increase in pituitary responsiveness to LHRH. The increase in pituitary responsiveness is further potentiated by another powerful servomechanism, the self-priming effect of LHRH, which has the additional role of coordinating increased pituitary responsiveness with the release of LHRH.

The self-priming effect of LHRH also enables the generation of an LH surge by small pulses (instead of a massive surge) of LHRH acting on an E_2 -primed pituitary gland. The self-priming effect is produced by a post-LHRH receptor intracellular signaling cascade which appears to involve a PKC-induced rearrangement of the gonadotrope cytoskeleton. The changes in the cytoskeleton result in a migration of secretory granules towards the gonadotrope plasmalemma (margination), thereby greatly potentiating gonadotropin release in response to a further pulse of secretagogue.

Estrogen stimulation of LHRH release is mediated by stimulatory, α_1 -adrenoreceptor and $5-HT_{2A}$ receptor mechanisms. Disinhibition may also play a role in that E_2 inhibits the biosynthesis and release of β -endorphin and the biosynthesis of dopamine, both of which inhibit LHRH release. Other central control mechanisms involving neuropeptide Y, galanin, GABA, and other transmitters may also be involved.

Estradiol stimulation of prolactin synthesis and release appears to parallel changes in the LHRH/LH mechanism. The LHRH/LH and prolactin surges may be generated by the same surge generator "module" in the brain. This involves a circadian signaling mechanism, probably the SCN, and neurons that send a surge command signal on exposure to high concentrations of E_2 . Different neurohormones, however, mediate the neural signal for LH and prolactin surge release, and under some situations the surges occur independently of one another.

CLINICAL SIGNIFICANCE OF ESTROGEN FEEDBACK AND THE LHRH SELF-PRIMING EFFECT

No attempt is made here to give a detailed account of the clinical applications of E_2 negative and positive feedback and the self-priming effect; attention will focus on key principles.

The negative feedback of female sex steroids is best exemplified by the massive increase in plasma gonadotropin concentrations that follows the menopause (Fink, 1977). Androgen negative feedback in man is best illustrated by the testicular feminization syndrome in which the absence or defect in the androgen receptor results in a significant increase in the mean plasma concentrations of LH and the frequency of LH pulses (Boyar et al., 1978). The negative feedback action of E_2 and progesterone underpins the extensive use of the most widely used chemical contraceptive, the "pill". Gregory Pincus, about 40 years ago, established the method of inducing reliable contraception in women by administration of estrogen and progesterone. Several different modes and dosages of administration have been

devised all based on the principle that continuous exposure to gonadal steroids inhibits gonadotropin secretion. Androgens are similarly effective in inhibiting gonadotropin secretion. However, their routine use as the long-sought male contraceptive, either alone or in combination with progestogens, has been prevented by the fact that as shown by several trials azoospermia (total lack of sperm in the ejaculate) and therefore secure contraception cannot be assured (Carr and Griffin, 1992).

Our understanding of the positive feedback control of LHRH and LH release, pulsatile LHRH/LH release, the self-priming effect of LHRH and pituitary refractoriness to continuous exposure to LHRH or its superactive agonists has revolutionized the diagnosis and treatment of infertility and offered alternative methods for contraception and the treatment of precocious puberty, cancer of the prostate and possibly breast, and uterine disorders (e.g. Schally et al., 1989; Conn and Crowley, 1991). The several conditions that cause infertility as a consequence of absent or defective LHRH secretion include Kallman's Syndrome (hypogonadotropic hypogonadism with varying degrees of anosmia), idiopathic hypogonadotropic hypogonadism without anosmia, pituitary tumors, panhypopituitarism, radiation damage, primary amenorrhea, secondary hypothalamic amenorrhea, and polycystic ovarian disease. These conditions all respond to pulsatile administration of LHRH which restores pituitary responsiveness to the negative and positive feedback effects of gonadal steroids. Treatment of hypothalamic infertility in women with appropriately administered pulsatile LHRH also carries the advantage over treatment with gonadotropins in that it does not lead to hyperstimulation and consequent multiple pregnancies.

Precocious puberty is mostly due to premature initiation of endogenous pulsatile LHRH release although LHRH-independent forms occur (Grumbach and Kaplan, 1990; Grave and Cutler, 1993). Hypothalamic precocious puberty is effectively treated with superactive agonists of LHRH which cause LHRH receptor downregulation, and thereby, reduced gonadotropin secretion with consequent interruption of precocious development. Left untreated, precocious development results in several disabilities including short adult stature due to premature closure of the epiphyses.

The same principle of using LHRH superactive agonists has been used to effect "chemical castration" in trials of the treatment of cancer of the prostate and the breast (Schally et al., 1989; Conn and Crowley, 1991). The principle of receptor downregulation by LHRH superactive agonists has also been used effectively in the treatment of uterine fibroids and endometriosis. The major drawback, the decrease in bone density which occurs in some women, may be overcome by parallel administration of progestogens which reduce osteoporosis. Superactive LHRH agonists have also proved highly effective in *in vitro* fertilization in preventing the unpredictable occurrence of spontaneous LH surges (Conn and Crowley, 1991).

The study of gonadal steroid feedback can also have important benefits for our wider understanding of brain function. Thus, for example, E_2 exerts a profound effect on mood and mental function in the human (Wieck et al., 1991; Rapkin, 1992; Wood et al., 1992) possibly by effects on brain monoamine, and in particular 5-HT mechanisms (Meltzer and Lowry, 1987; Rapkin, 1992; Wood et al., 1992; Zifa and Fillion, 1992; O'Brien, 1993). The precipitous fall in plasma E_2 concentrations has been implicated in the premenstrual syndrome and *post-partum* psychosis (Rapkin, 1992; Wood et al., 1992) and the high levels of E_2 may explain the fact that the average age of onset of schizophrenia is much later in women than in men (Seeman and Lang, 1990; Wieck et al., 1991; Lewis, 1992). Based on our finding that E_2 in its positive feedback mode selectively stimulates the expression of 5-HT_{2A} receptor mRNA in the dorsal raphe nucleus of the female rat (Sumner and Fink, 1993), we have investigated the effects of E_2 on the density of 5-HT_{2A} receptors in brain. Our results show that a single pulse of E_2 induces a significant increase in the density of 5-HT_{2A} receptors in several areas of the brain, particularly the anterior frontal, anterior cingulate and primary olfactory cortex, and the nucleus accumbens (Sumner and Fink, 1995; Fink and Sumner 1976). Since these brain regions play a pivotal role in cognition and emotion, and since 5-HT and especially 5-HT_{2A} mechanisms are involved in psychoses (Janssen et al., 1988; Meltzer et al., 1989; Leysen et al., 1992; Rapkin, 1992; Wood et al., 1992; Zifa and Fillion, 1992; Duinkerke et al., 1993; O'Brien, 1993), our findings provide the first experimental evidence for the fact that estrogen could alter mood and mental state by increasing the density of 5-HT_{2A} receptors in cerebral cortex and nucleus accumbens. The importance of estrogen-serotonergic interactions for mental state, mood, and emotions is underscored by our recent discovery that E_2 , in its positive feedback mode for LHRH release, also induces a substantial increase in the serotonin transporter (SERT) mRNA in the dorsal raphe nucleus and SERT sites in the basolateral amygdala, ventromedial hypothalamic nucleus, ventral thalamus, and lateral septum (McQueen et al., 1997).

OVERALL CONCLUSIONS AND HYPOTHESES

Glucocorticoid and estrogen feedback illustrate several important principles. First, steroid effects are system- and tissue-specific and depend on the strength and duration of steroid exposure. Thus, the action of glucocorticoids in the HPA is always inhibitory, but, as shown by the glucocorticoid stimulation of CRF-41 stimulation in PVN neurons that project to the brain stem, functional specificity is determined by cell responses rather than the steroid. In the case of estrogen, the same steroid exerts negative and positive feedback in the HPG, depending on the concentration of E_2 and the state of the HPG (e.g. whether or not the HPG has been exposed to progesterone). The possible number of different steroid actions is increased by virtue of the fact that steroids exert genomic as well as extragenomic effects. Second, neurohormone/hormone synthesis and release in both the HPG and

HPA are in the same direction. Thus, glucocorticoids inhibit CRF-41 synthesis and release and ACTH synthesis and release. Estradiol, in its positive feedback mode, stimulates LHRH synthesis and release. However, whether synthesis and release are mechanistically linked has not been established. Third, all feedback loop variables also operate in the same direction. Thus, glucocorticoids inhibit CRF-41 release and pituitary responsiveness to CRF-41. Estrogen in its negative feedback mode inhibits pulse frequency and amplitude and pituitary responsiveness. In its positive feedback mode, E_2 stimulates LHRH release and pituitary responsiveness to LHRH. The priming effect of LHRH, a major component of the E_2 positive feedback mechanism for the ovulatory LH surge further potentiates pituitary responsiveness and coordinates it with LHRH release so that both reach a peak simultaneously. Both the HPA and HPG depend on circadian drive, probably generated by the SCN. In the HPA this generates the well-defined circadian rhythm of ACTH/cortisol, while in the HPG it generates the daily neural signal for LHRH release which is crucial for regular reproductive cycles. The hippocampus and amygdala have long been implicated in the control of both the HPA and HPG, but there is no evidence that these prominent components of the limbic system exert acute control in either system. Rather, it seems that the limbic system exerts long-term effects, including determination of feedback set point in the HPA and HPG systems.

The three types of feedback systems described offer powerful and precise models for studying steroid action, tissue- and cell-specific gene regulation, the nature of complex neural circuitry in mammalian brain, and intracellular signaling mechanisms. The feedback systems also offer a remarkable set of models for "biological economy". Thus, in addition to affecting gonadotropin release, E_2 is also essential for lordosis behavior and for increased motor activity that both reach a peak at the time of ovulation early on estrus in the rat. That is, the same steroid secreted by the ovary activates in a precisely timed manner the mechanisms (amplifier cascades) required for the ovulatory surge of LH, mating, and maintenance of the corpus luteum (by triggering the prolactin surge). At low plasma concentrations, E_2 moderates gonadotropin release. The positive feedback action of E_2 is greatly potentiated by the self-priming effect of LHRH, the intracellular mechanism of which provides a valuable biochemical model for long-term potentiation in forebrain. The intracellular signaling cascade involved in LHRH priming, PKC-induced rearrangement of the cytoskeleton which leads to migration of the secretory granules towards the gonadotrope cell membrane (margination), mirrors the events which result in leukocyte activation. Similarly, calcineurin which may serve as a Ca^{2+} sensor in glucocorticoid feedback inhibition in the HPA system also plays an important role as a signaling protein in lymphocytes.

Disruption of the feedback systems can have serious deleterious effects. Disruption of the glucocorticoid negative feedback loop results in the overstimulation of the adrenal cortex by ACTH, resulting in increased androgen secretion and hence the adrenogenital syndrome. Without hypothalamic-pituitary sensitivity to gluco-

corticoid negative feedback, glucocorticoid secretion would proceed in an uncontrolled manner and lead, by causing lymphocyte death, to endocrine-induced immune deficiency syndrome. Elevation of the central set point for HPA control occurs in major depression, other psychoses, and dementia, and could conceivably predispose to illnesses which are caused or enhanced by immune suppression. Without the positive feedback stimulation of the ovulatory LHRH/LH surge there would be no reproduction of spontaneously ovulating mammals. It is perhaps hardly surprising, therefore, that there are several backup systems by means of which E_2 can trigger LHRH synthesis and release and that LHRH has the unique property of increasing pituitary responsiveness to itself (priming effect).

Finally, studies on steroid feedback can increase significantly our understanding of wider brain function. Thus, for example, E_2 in its positive feedback mode stimulates a massive increase in the 5-HT_{2A} receptor mRNA in the dorsal raphe nucleus and the density of 5-HT_{2A} receptors in the cerebral cortex and nucleus accumbens. Estradiol-17 β also induces a substantial increase in the amount of serotonin transporter mRNA in the dorsal raphe nucleus with a concomitant increase in the density of serotonin transporter sites in brain regions concerned with emotion and behavior. These findings may explain the powerful effects of E_2 on mood and mental state; the precipitous fall in plasma E_2 concentrations has been implicated in the premenstrual syndrome, post-partum psychoses, and menopausal depression, and E_2 has been postulated to delay the onset of schizophrenia in women.

Overall, this account underscores the old adage that the evolution of hormones is not about changes in their structure but rather in the uses (i.e. receptors) to which they are put. We now know that the effect of a steroid depends not only on the structure and function of its effector gene but also on cell-specific variations in transcription factors that determine gene expression and cell/system function.

ACKNOWLEDGMENT

I should like to thank Lorraine Martin for her excellent preparation of the typescript.

REFERENCES

- Aderem, A. (1992). The MARCKS brothers: a family of protein kinase C substrates. *Cell* 71, 713–716.
- Aiyer, M.S., Chiappa, S.A., & Fink, G. (1974a). A priming effect of luteinizing hormone releasing factor on the anterior pituitary gland in the female rat. *J. Endocrinol.* 62, 573–588.
- Aiyer, M.S., & Fink, G. (1974). The role of sex steroid hormones in modulating the responsiveness of the anterior pituitary gland to luteinizing hormone releasing factor in the female rat. *J. Endocrinol.* 62, 553–572.
- Aiyer, M.S., Fink, G., & Greig, F. (1974b). Changes in the sensitivity of the pituitary gland to luteinizing hormone releasing factor during the oestrous cycle of the rat. *J. Endocrinol.* 60, 47–64.
- Aiyer, S., Sood, M.C., & Brown-Grant, K. (1976). The pituitary response to exogenous luteinizing hormone releasing factor in steroid-treated gonadectomized rats. *J. Endocrinol.* 69, 255–262.

- Antoni, F.A. (1986). Hypothalamic control of adrenocorticotropin secretion: advances since the discovery of 41-residue corticotropin-releasing factor. *Endocr. Rev.* 7, 351–378.
- Antoni, F.A., Barnard, R.J.O., Shipston, M.J., Smith, S.M., Simpson, J., & Paterson, J.M. (1995). Calcineurin feedback inhibition of agonist-evoked cAMP formation. *J. Biol. Chem.* 270, 28055–28061.
- Antoni, F.A., Fink, G., & Sheward, W.J. (1990). Corticotrophin-releasing peptides in rat hypophysial portal blood after paraventricular lesions: a marked reduction in the concentration of corticotrophin-releasing factor-41, but no change in vasopressin. *J. Endocrinol.* 125, 175–183.
- Antoni, F.A., Hunter, E.F.M., Lowry, P.J., Noble, J.M., & Seckl, J.R. (1992). Atriopeptin: an endogenous corticotropin-release inhibiting hormone. *Endocrinology* 130, 1753–1755.
- Badger, T.M., Wilcox, C.E., Meyer, E.R., Bell, R.D., & Cicero, T.J. (1978). Simultaneous changes in tissue and serum levels of luteinizing hormone, follicle-stimulating hormone, and luteinizing hormone/follicle-stimulating hormone releasing factor after castration in the male rat. *Endocrinology* 102, 136–141.
- Barraclough, C.A. (1966). Modifications in the CNS regulation of reproduction after exposure of prepubertal rats to steroid hormones. *Recent Prog. Horm. Res.* 22, 503–529.
- Barrell, G.K., Moenter, S.M., Caraty, A., & Karsch, F.J. (1992). Seasonal changes of gonadotropin-releasing hormone secretion in the ewe. *Biol. Reprod.* 46, 1130–1135.
- Bergen, K., & Leung, P.C.K. (1987). Electrical stimulation of ventral versus dorsal mesencephalic tegmental areas in the conscious rat: effects on luteinizing hormone release. *Neuroendocrinology* 46, 117–124.
- Berkenbosh, F., Van Dam, A.R., Deryk, R., & Schotanus, K. (1992). In: *Stress: Neuroendocrine and Molecular Approaches* (Kvetnansky, R., McCarthy, R., & Axelrod, J., Eds.), pp. 623–640. Gordon & Breach Science Publishers, New York.
- Besecke, L.M., Wolfe, A.M., Pierce, M.E., Takahashi, J.S., & Levine, J.E. (1994). Neuropeptide Y stimulates luteinizing hormone-releasing hormone release from superfused hypothalamic GT₁-7 cells. *Endocrinology* 135, 1621–1627.
- Besedovsky, H., del Rey, A., Sorokin, E., & Dinarello, C.A. (1986). Immunoregulatory feedback between interleukin-1 and glucocorticoid hormones. *Science* 221, 564–566.
- Bittman, E.L., Kaynard, A.H., Olster, D.H., Robinson, J.E., Yellow, S.M., & Karsch, F.J. (1985). Pineal melatonin mediates photoperiodic control of pulsatile luteinizing hormone secretion in the ewe. *Neuroendocrinology* 40, 409–418.
- Blake, C.A. (1976). Simulation of the proestrous luteinizing hormone (LH) surge after infusion of LH-releasing hormone in phenobarbital-blocked rats. *Endocrinology* 98, 451–460.
- Boyar, J.C.E.M., Moore, R.J., Rosner, W., Aiman, J., Chipman, J., Madden, J.D., Marks, J.F., & Griffin, J.E. (1978). Studies of gonadotropin-gonadal dynamics in patients with androgen insensitivity. *J. Clin. Endocrinol. Metab.* 47, 1116–1122.
- Brar, A.K., McNeilly, A.S., & Fink, G. (1985). Effects of hyperprolactinaemia and testosterone on the release of LH-releasing hormone and the gonadotrophins in intact and castrated rats. *J. Endocrinol.* 104, 35–43.
- Brown-Grant, K., & Raisman, G. (1977). Abnormalities in reproductive function associated with the destruction of the suprachiasmatic nuclei in female rats. *Proc. R. Soc. Lond. [Biol]* 198, 279–296.
- Canny, B.J., Clarke, I.J., & Funder, J.W. (1990). Adrenocorticotropin responses to endogenous and exogenous secretagogues in the sheep: Specificity of glucocorticoid action. *Neuroendocrinology* 51, 181–189.
- Caraty, A., & Locatelli, A. (1988). Effect of time after castration on secretion of LHRH and LH in the ram. *J. Reprod. Fertil.* 82, 263–269.
- Caraty, A., Locatelli, A., & Martin, G.B. (1989). Biphasic response in the secretion of gonadotropin-releasing hormone in ovariectomized ewes injected with oestradiol. *J. Endocrinol.* 123, 375–382.
- Carr, B.R., & Griffin, J.E. (1992). In: *Williams Textbook of Endocrinology* (Wilson, J.D. & Foster, D.W., Eds.), pp. 1007–1031. W.B. Saunders Company, Philadelphia.

- Carroll, B., Feinberg, M., Greden, J., Tarika, J., Albala, A., Haskett, R., James, N., Kronfol, Z., Lohr, N., Steiner, M., De Vigne, J., & Young, E. (1981). A specific laboratory test for the diagnosis of melancholia. *Arch. Gen. Psychiatry* 38, 15–22.
- Chadwick, D.J., Marsh, J., & Ackrill, K. (1993). In: *Corticotropin-Releasing Factor*, Ciba Foundation Symposium 172, pp. 357. John Wiley & Sons, Chichester.
- Chadwick, D., & Widdows, K. (1990). In: *Ciba Foundation Symposium 153*, pp. 284, John Wiley & Sons, Chichester.
- Chen, W.-P., Witkin, J.W., & Silverman, A.-J. (1989). Beta-endorphin and gonadotropin-releasing hormone synaptic input to gonadotropin-releasing hormone neurosecretory cells in the male rat. *J. Comp. Neurol.* 286, 85–95.
- Chiappa, S.A., & Fink, G. (1977). Hypothalamic luteinizing hormone releasing factor and corticotrophin releasing activity in relation to pituitary and plasma hormone levels in male and female rats. *J. Endocrinol.* 72, 195–210.
- Chiappa, S.A., Fink, G., & Sherwood, N.M. (1977). Immunoreactive luteinizing hormone releasing factor (LRF) in pituitary stalk plasma from female rats: effects of stimulating diencephalon, hippocampus and amygdala. *J. Physiol.* 267, 625–640.
- Ching, M. (1982). Correlative surges of LHRH, LH and FSH in pituitary stalk plasma and systemic plasma of rat during proestrus. *Neuroendocrinology* 34, 279–285.
- Christie, J.E., Whalley, L.J., Bennie, J., Dick, H., Blackburn, I.M., Blackwood, D.H.R., & Fink, G. (1987). Characteristic plasma hormone changes in Alzheimer's disease. *Br. J. Psychiatry* 150, 674–681.
- Christie, J.E., Whalley, L.J., Dick, H., Blackwood, D.H.R., Blackburn, I.M., & Fink, G. (1986). Raised plasma cortisol concentrations are a feature of drug-free psychotics and not specific for depression. *Br. J. Psychiatry* 148, 58–65.
- Cicero, T.J., Meyer, E.R., Gabriel, S.M., Bell, R.D., & Wilcox, C.E. (1980). Morphine exerts testosterone-like effects in the hypothalamus of the castrated male rat. *Brain Res.* 202, 151–164.
- Clayton, R.N., Young, L.S., Naik, S.I., Detta, A., & Abbot, S.D. (1986). In: *Neuroendocrine Molecular Biology* (Fink, G., Harmar, A.J. & McKerns, K.W., Eds.), pp. 429–440. Plenum Press, New York.
- Conn, P.M., & Crowley Jr, W.F. (1991). Gonadotropin-releasing hormone and its analogues. *N. Engl. J. Med.* 324, 93–103.
- Cooper, K.J., Fawcett, C.P., & McCann, S.M. (1974). Inhibitory and facilitatory effects of estradiol-17 β on pituitary responsiveness to a luteinizing hormone-follicle stimulating hormone releasing factor (LH-RF/FSH-RF) preparation in the ovariectomized rats. *Proc. Soc. Exp. Biol. Med.* 145, 1422–1426.
- Copolov, D.L., Rubin, R.T., Stuart, G.W., Poland, R.E., Mander, A.J., Sashidharan, S.P., Whitehouse, A.M., Blackburn, I.M., Freeman, C.P., & Blackwood, D.H.R. (1989). Specificity of the salivary cortisol dexamethasone suppression test across psychiatric diagnoses. *Biol. Psychiatry* 25, 879–893.
- Cross, B.A. (1973). In: *Frontiers in Neuroendocrinology* (Ganong, W.F., & Martini, L., Eds.), pp. 133–171. Oxford University Press, Oxford.
- Curtis, A., Lyons, V., & Fink, G. (1985). The priming effect of LH-releasing hormone: effects of cold and involvement of new protein synthesis. *J. Endocrinol.* 105, 163–167.
- Dallman, M.F. (1993). *Stress Update: Adaptation of the hypothalamic-pituitary-adrenal axis to chronic stress.* *Trends Endocrinol. Metab.* 4, 62–69.
- Dallman, M.F., Akana, S.F., Cascio, C.S., Darlington, D.N., Jacobson, L., & Levin, N. (1987). Regulation of ACTH secretion: variations on a theme of B. *Recent Prog. Horm. Res.* 43, 113–173.
- Dallman, M.F., & Jones, M.T. (1973). Corticosteroid feedback control of ACTH secretion: effect of stress-induced corticosterone secretion on subsequent stress responses in the rat. *Endocrinology* 92, 1367–1375.

- Dallman, M.F., Levin, N., Cascio, C.S., Akana, S.F., Jacobson, L., & Kuhn, R.W. (1989). Pharmacological evidence that the inhibition of diurnal adrenocorticotropin secretion by corticosteroids is mediated via type I corticosterone-preferring receptors. *Endocrinology* 124, 2844–2850.
- Dallman, M.F., & Yates, F.E. (1969). Dynamic asymmetries in the corticosteroid feedback path and distribution-metabolism-binding elements of the adrenocortical system. *Ann. N.Y. Acad. Sci.* 156, 696–721.
- Dayanithi, G., & Antoni, F.A. (1989). Rapid as well as delayed inhibitory effects of glucocorticoid hormones on pituitary adrenocorticotropin release are mediated by type II glucocorticoid receptors and require newly synthesized messenger ribonucleic acid as well as protein. *Endocrinology* 125, 308–313.
- Dayanithi, G., & Antoni, F.A. (1990). Atriopeptins are potent inhibitors of ACTH secretion by rat anterior pituitary cells *in vitro*; involvement of the atrial natriuretic factor receptor domain of membrane-bound guanylyl cyclase. *J. Endocrinol.* 125, 39–44.
- de Greef, W.J., Klootwijk, W., Karels, B., & Visser, T.J. (1985). Levels of dopamine and thyrotrophin-releasing hormone in hypophysial stalk blood during an oestrogen-stimulated surge of prolactin in the ovariectomized rat. *J. Endocrinol.* 112, 351–359.
- Dewailly, D., Vantghem-Haudiouet, M.-C., Sainsard, C., Buvat, J., Cappelletti, J.P., Ardaens, K., Racadot, A., Lefebvre, J., & Fossati, P. (1986). Clinical and biological phenotypes in late-onset 21-hydroxylase deficiency. *J. Clin. Endocrinol. Metab.* 63, 418–423.
- Dierschke, D.J., Bhattacharya, A.N., Atkinson, L.E., & Knobil, E. (1970). Circadian oscillations of plasma LH levels in the ovariectomized rhesus monkey. *Endocrinology* 87, 850–853.
- Djahanbakhch, O., McNeilly, A.S., Warner, P.M., Swanston, I.A., & Baird, D.T. (1984). Changes in plasma levels of prolactin, in relation to those of FSH, oestradiol, androstenedione and progesterone around the preovulatory surge of LH in women. *Clin. Endocrinol.* 20, 463.
- Dluzen, D.E., & Ramirez, V.D. (1985). *In vivo* activity of the LH-releasing hormone pulse generator in castrated and intact male rats. *J. Endocrinol.* 107, 331–340.
- Dow, R.C., Williams, B.C., Bennie, J., Carroll, S., & Fink, G. (1994). A central 5-HT₂ receptor mechanism plays a key role in the proestrous surge of luteinizing hormone but not prolactin in the rat. *Psychoneuroendocrinology* 19, 395–399.
- Drouin, J., & Labrie, F. (1976). Selective effect of androgens on LH and FSH release in anterior pituitary cells in culture. *Endocrinology* 98, 1528–1534.
- Drouin, J., Sun, Y.L., Chamberland, M., Gauthier, Y., De Léan, A., Nemer, M., & Schmidt, T.J. (1993). Novel glucocorticoid receptor complex with DNA element of the hormone-repressed POMC gene. *EMBO J.* 12, 145–156.
- Duinkerke, S.J., Botter, P.A., Jansen, A.A.I., van Dongen, P.A.M., van Haafden, A.J., Boom, A.J., van Laarhoven, J.H.M., & Busard, H.L.S.M. (1993). Ritanserin, a selective 5-HT₂/1C antagonist, and negative symptom in schizophrenia. A placebo-controlled double-blind trial. *Br. J. Psychiatry* 163, 451–455.
- Dyer, R.G. (1973). An electrophysiological dissection of the hypothalamic regions which regulate the preovulatory secretion of luteinizing hormone in the rat. *J. Physiol.* 234, 421–442.
- Edwards, C.R.W., Burt, D., McIntyre, M.A., de Kloet, E.R., Stewart, P.M., Brett, L., Sutanto, W.S., & Monder, C. (1988). Localization of 11 β -hydroxysteroid dehydrogenase-tissue specific protector of the mineralocorticoid receptor. *Lancet* ii, 986–989.
- Engeland, W.C., Shinsako, J., Winget, C.M., Vernikos-Danellis, J., & Dallman, M.F. (1977). Circadian patterns of stress induced ACTH secretion are modified by corticosterone responses. *Endocrinology* 100, 138–147.
- Evans, N.P., Dahl, G.E., Glover, B.H., & Karsch, F.J. (1994). Central regulation of pulsatile gonadotropin-releasing hormone (GnRH) secretion by estradiol during the period leading up to the preovulatory GnRH surge in the ewe. *Endocrinology* 134, 1806–1811.
- Everett, J.W., & Sawyer, C.H. (1950). A 24-hour periodicity in the 'LH-release apparatus' of female rats, disclosed by barbiturate sedation. *Endocrinology* 47, 198–218.

- Feder, H.H., Brown-Grant, K., & Corker, C.S. (1971). Pre-ovulatory progesterone, the adrenal cortex and the 'critical period' for luteinizing hormone release in rats. *J. Endocrinol.* 50, 29–39.
- Fink, G. (1976). The development of the releasing factor concept. *Clin. Endocrinol.* 5, Suppl., 245s–260s.
- Fink, G. (1977). In: *Recent Advances in Obstetrics and Gynecology* (Stallworthy, J., & Bourne, G., Eds.), pp. 3–54. Churchill Livingstone, London.
- Fink, G. (1979a). Feedback actions of target hormones on hypothalamus and pituitary with special reference to gonadal steroids. *Ann. Rev. Physiol.* 41, 571–585.
- Fink, G. (1979b). Neuroendocrine control of gonadotrophin secretion. *Br. Med. Bull.* 35, 155–160.
- Fink, G. (1985). Has the prolactin inhibiting peptide at last been found? *Nature* 316, 487–488.
- Fink, G. (1988a). Oestrogen and progesterone interactions in the control of gonadotrophin and prolactin secretion. *J. Steroid Biochem.* 30, 169–178.
- Fink, G. (1988b). The G.W. Harris Lecture. Steroid control of brain and pituitary function. *Q. J. Exp. Physiol.* 73, 257–293.
- Fink, G., Aiyer, M., Chiappa, S., Henderson, S., Jamieson, M., LevyPerez, V., Pickering, A., Sarkar, D., Sherwood, N., Speight, A., & Watts, A. (1982a). In: *Hormonally Active Brain Peptides: Structure and Function* (McKerns, K., Eds.), pp. 397–426. Plenum Press, New York.
- Fink, G., Chiappa, S.A., & Aiyer, M.S. (1976). Priming effect of luteinizing hormone releasing factor elicited by preoptic stimulation and by intravenous infusion and multiple injections of the synthetic decapeptide. *J. Endocrinol.* 69, 359–372.
- Fink, G., Dow, R.C., Casley, D., Johnston, C.I., Bennie, J., Carroll, S., & Dick, H. (1992). Atrial natriuretic peptide is involved in the ACTH response to stress and glucocorticoid negative feedback in the rat. *J. Endocrinol.* 135, 37–43.
- Fink, G., Dow, R.C., Casley, D., Johnston, C.I., Lim, A.T., Copolov, D.L., Bennie, J., Carroll, S., & Dick, H. (1991). Atrial natriuretic peptide is a physiological inhibitor of ACTH release: evidence from immunoneutralization *in vivo*. *J. Endocrinol.* 131, R9–R12.
- Fink, G., Dow, R.C., Sumner, B.E.H., Rosie, R., Grahame, L.M., Bennie, J., & Carroll, S. (1996). 5-Hydroxytryptamine_{2A} receptor antagonists block the oestradiol-17 β -induced surge of luteinizing hormone-releasing hormone (LHRH) into hypophysial portal blood but do not affect LHRH synthesis. *J. Physiol.* 495p, 117p.
- Fink, G., & Henderson, S.R. (1977). Steroids and pituitary responsiveness in female, androgenized female and male rats. *J. Endocrinol.* 73, 157–164.
- Fink, G., & Jamieson, M.G. (1976). Immunoreactive luteinizing hormone releasing factor in rat pituitary stalk blood: effects of electrical stimulation of the medial preoptic area. *J. Endocrinol.* 68, 71–87.
- Fink, G., Koch, Y., & Ben Aroya, N. (1982b). Release of thyrotropin releasing hormone into hypophysial portal blood is high relative to other neuropeptides and may be related to prolactin secretion. *Brain Res.* 243, 186–189.
- Fink, G., & Pickering, A. (1980). In: *Synthesis and Release of Adenohypophyseal Hormones* (Jutisz, M., & McKerns, K.W., Eds.), pp. 617–638. Plenum Press, New York.
- Fink, G., Robinson, I.C.A.F., & Tannahill, L.A. (1988). Effects of adrenalectomy and glucocorticoids on the peptides, CRF-41, AVP and oxytocin in rat hypophysial portal blood. *J. Physiol.* 401, 329–345.
- Fink, G., Stanley, H.F. & Watts, A.G. (1983). In: *Brain Peptides* (Krieger, D., Brownstein, M., & Martin, J., Eds.), pp. 413–435. John Wiley and Sons, New York.
- Fink, G., & Sumner, B.E.H. (1996). Oestrogen and mental state. *Nature* 383, 306.
- Fullerton, M.J., Krozowski, Z.S., & Funder, J.W. (1991). Adrenalectomy and dexamethasone administration: effect on atrial natriuretic peptide synthesis and circulating forms. *Mol. Cell. Endocrinol.* 82, 33–40.
- Gagner, J.-P., & Drouin, J. (1985). Opposite regulation of pro-opiomelanocortin gene transcription by glucocorticoids and CRH. *Mol. Cell. Endocrinol.* 40, 25–32.

- Gerken, A., & Holsboer, F. (1986). Cortisol and corticosterone response after syn-corticotropin in relationship to dexamethasone suppressibility of cortisol. *Psychoneuroendocrinology* 11, 185–194.
- Gibbs, D.M. (1986). Vasopressin and oxytocin: hypothalamic modulators of the stress response: a review. *Psychoneuroendocrinology* 11, 131–140.
- Gindoff, P.R., Jewelewicz, R., Hembree, W., Wardlaw, S., & Ferin, M. (1988). Sustained effects of opioid antagonism during the normal human luteal phase. *J. Clin. Endocrinol. Metab.* 66, 1000–1004.
- Goodwin, G.M., Austin, M.-P., Curran, S.M., Ross, M., Murray, C., Prentice, N., Ebmeier, K.P., Bennie, J., Carroll, S., Dick, H., & Fink, G. (1993). The elevation of plasma β -endorphin levels in major depression. *J. Affective Disord.* 29, 281–289.
- Gormley, G., Lowy, M., Reder, A., Horspeltorn, V., Antel, J., & Meltzer, H. (1985). Glucocorticoid receptors in depression: relationship to the dexamethasone suppression test. *Am. J. Psychiatry* 142, 1278–1284.
- Grahame, L., Sumner, B.E.H., Rosie, R., & Fink, G. (1994). The effect of 5-HT_{2A} receptor antagonists on LHRH mRNA biosynthesis in the female rat. *Physiological Society Meeting, Birmingham* (Dec., 1994).
- Grave, G.D., & Cutler, G.B. (1993). *Sexual Precocity: Etiology, Diagnosis, and Management*, pp. 300. Raven Press, New York.
- Gray, T.S., Carney, M.E., & Magnuson, D.J. (1989). Direct projections from the central amygdaloid nucleus to the hypothalamic paraventricular nucleus: possible role in stress-induced adrenocorticotropin release. *Neuroendocrinology* 50, 433–446.
- Gregg, D.W., Schwall, R.H., & Nett, T.M. (1991). Regulation of gonadotropin secretion and number of gonadotropin-releasing hormone receptors by inhibin, activin A and estradiol. *Biol. Reprod.* 44, 725–732.
- Grosser, P.M., O'Byrne, K.T., Williams, C.L., Thalabard, J.-C., Hotchkiss, J., & Knobil, E. (1993). Effects of naloxone on estrogen-induced changes in hypothalamic gonadotropin-releasing hormone pulse generator activity in the rhesus monkey. *Neuroendocrinology* 57, 115–119.
- Grumbach, M.M., & Conte, F.A. (1992). In: *Williams Textbook of Endocrinology* (Wilson, J.D., & Foster, D.W., Eds.), pp. 853–951. W.B. Saunders, Philadelphia.
- Grumbach, M.M., & Kaplan, S.L. (1990). In: *Control of the Onset of Puberty* (Grumbach, M.M., Sizonenko, P.C., & Aubert, M.L., Eds.), pp. 1–68. Williams & Wilkins, Baltimore.
- Härfstrand, A., Fuxe, K., Cintra, A., Agnati, L.F., Zini, I., Wikström, A.-C., Okret, S., Yu, Z.-Y., Goldstein, M., Steinbusch, H., Verhofstad, A., & Gustafsson, J.-A. (1986). Glucocorticoid receptor immunoreactivity in monoaminergic neurons of rat brain. *Proc. Natl. Acad. Sci. USA* 83, 9779–9783.
- Harris, G.W. (1970). Hormonal differentiation of the developing central nervous system with respect to patterns of endocrine function. *Philos. Trans. R. Soc. Lond.* 259, 165–177.
- Hartwig, J.H., Theien, M., Rosen, A., Janney, P.A., Nairn, A.C., & Aderem, A. (1992). MARCKS is an actin filament crosslinking protein regulated by protein kinase C and calcium-calmodulin. *Nature* 356, 618–622.
- Hayward, J.N. (1977). Functional and morphological aspects of hypothalamic neurons. *Physiol. Rev.* 57, 574–658.
- Henderson, S.R., Baker, C., & Fink, G. (1977a). Effects of oestradiol-17 β exposure on the spontaneous secretion of gonadotrophins in chronically gonadectomized rats. *J. Endocrinol.* 73, 455–462.
- Henderson, S.R., Baker, C., & Fink, G. (1977b). Oestradiol-17 β and pituitary responsiveness to luteinizing hormone releasing factor in the rat: a study using rectangular pulses of oestradiol-17 β monitored by non-chromatographic radioimmunoassay. *J. Endocrinol.* 73, 441–453.
- Herbert, J. (1993). Peptides in the limbic system: neurochemical codes for co-ordinated adaptive responses to behavioral and physiological demand. *Prog. Neurobiol.* 41, 723–791.

- Herbison, A.E., & Dyer, R.G. (1991). Effect on luteinizing hormone secretion of GABA receptor modulation in the medial preoptic area at the time of proestrous luteinizing hormone surge. *Neuroendocrinology* 53, 317–320.
- Herman, J.P., Cullinan, W.E., & Watson, S.J. (1994). Involvement of the bed nucleus of the stria terminalis in tonic regulation of paraventricular hypothalamic CRH and AVP mRNA expression. *J. Neuroendocrinol.* 6, 433–442.
- Herman, J.P., Cullinan, W.E., Young, E.A., Akil, H., & Watson, S.J. (1992b). Selective forebrain fiber tract lesions implicate ventral hippocampal structures in tonic regulation of paraventricular nucleus corticotropin-releasing hormone (CRH) and arginine vasopressin (AVP) mRNA expression. *Brain Res.* 592, 228–238.
- Herman, J.P., Schafer, M.K.H., Thompson, R.C., & Watson, S.J. (1992a). Rapid regulation of corticotropin-releasing hormone gene transcription *in vivo*. *Mol. Endocrinol.* 6, 1061–1069.
- Holaday, J.W., Martinex, H.M., & Natelson, B.H. (1977). Synchronized ultradian cortisol rhythms in monkeys: persistence during corticotropin infusion. *Science* 198, 56–58.
- Horn, A.M., & Fink, G. (1985). Effects of 5-hydroxytryptamine uptake blockers on the release of LH and prolactin in several different experimental steroid models in the rat. *J. Endocrinol.* 104, 397–406.
- Hunter, R., Dick, H., Christie, J.E., Goodwin, G.M., & Fink, G. (1988). Lymphocyte glucocorticoid receptor binding in depression: normal values following recovery. *J. Affective Disord.* 14, 155–159.
- Ibuka, N., & Kawamura, H. (1975). Loss of circadian rhythm in sleep-wakefulness cycle in the rat by suprachiasmatic lesions. *Brain Res.* 96, 76–81.
- Ison, A.J., MacEwan, D.J., Johnson, M.S., Clegg, R.A., Connor, K., & Mitchell, R. (1993). Evidence for a distinct H7-resistant form of protein kinase C in rat anterior pituitary gland. *FEBS Lett.* 329, 199–204.
- Jakubowski, M., & Terkel, J. (1986). Nocturnal surges and reflexive release of prolactin in parentally behaving virgin female and male rats. *Horm. Behav.* 20, 270–286.
- Janssen, P.A.J., Niemegeers, C.J.E., Awouters, F., Schellekens, K.H.L., Megans, A.A.H.P., & Meert, T.F. (1988). Pharmacology of risperidone (R 64 766), a new antipsychotic with serotonin-5₂ and dopamine-D₂ antagonistic properties. *J. Pharmacol. Exp. Ther.* 244, 685–693.
- Jarry, H., Perschl, A., & Wutke, W. (1988). Further evidence that preoptic anterior hypothalamic GABAergic neurons are part of the GnRH pulse and surge generator. *Acta Endocrinol.* 118, 573–579.
- Jennes, L., Beckman, W.C., Stumpf, W.E., & Grzanna, R. (1982). Anatomical relationships of serotonergic and noradrenergic projections with the GnRH system in septum and hypothalamus. *Exp. Brain Res.* 46, 331–338.
- Johnson, M.S., Mitchell, R., & Thomson, F.J. (1992). The priming effect of luteinizing hormone releasing hormone (LHRH) but not LHRH-induced gonadotropin release, can be prevented by certain protein kinase C inhibitors. *Mol. Cell. Endocrinol.* 85, 183–193.
- Jones, E.G., & Powell, T.P.S. (1970). An anatomical study of converging sensory pathways within the cerebral cortex of the monkey. *Brain* 93, 793–820.
- Kaiser, U.B., Jakubowiak, A., Steinberger, A., & Chin, W.W. (1993). Regulation of rat pituitary gonadotropin-releasing hormone receptor mRNA levels *in vivo* and *in vitro*. *Endocrinology* 133, 931–934.
- Kalra, P.S., Crowley, W.R., & Kalra, S.P. (1987). Differential *in vitro* stimulation by naloxone and K⁺ of luteinizing hormone-releasing hormone and catecholamine release from the hypothalamus of intact and castrated rats. *Endocrinology* 120, 178–185.
- Kalra, P.S., & Kalra, S.P. (1980). Modulation of hypothalamic luteinizing hormone-releasing hormone levels by intracranial and subcutaneous implants of gonadal steroids in castrated rats: Effects of androgen and estrogen antagonists. *Endocrinology* 106, 390–397.

- Kalra, S., & Kalra, P. (1984). Opioid-adrenergic-steroid connection in regulation of luteinizing hormone secretion in the rat. *Prog. Neuroendocrinol.* 38, 418–426.
- Kalra, S.P., & Kalra, P.S. (1989). Do testosterone and estradiol-17 β enforce inhibition or stimulation of luteinizing hormone-releasing hormone secretion? *Biol. Reprod.* 41, 559–570.
- Kaplitt, M.G., Keopoulos, S.P., Pfaff, D.W., & Mobbs, C.V. (1993). Estrogen increases HIP-70/PLC- α messenger ribonucleic acid in the rat uterus and hypothalamus. *Endocrinology* 133, 99–104.
- Karsch, F.J., Bittman, E.L., Foster, D.L., Goodman, R.L., Legan, S.J., & Robinson, J.E. (1984). Neuroendocrine basis of seasonal reproduction. *Recent Prog. Horm. Res.* 40, 185–225.
- Karsch, F.J., Dahl, G.E., Evans, N.P., Manning, J.M., Mayfield, K.P., Moenter, S.M., & Foster, D.L. (1993). Seasonal changes in gonadotropin-releasing hormone secretion in the ewe: alteration in response to the negative feedback action of estradiol. *Biol. Reprod.* 49, 1377–1383.
- Kelly, M.J., Ronnekleiv, O.K., & Eskay, R.L. (1982). Immunocytochemical localization of luteinizing hormone-releasing hormone in neurons in the medial basal hypothalamus of the female rat. *Exp. Brain Res.* 48, 97–106.
- Kerdelhué, B., Parnet, P., Lenoir, V., Schirar, A., Gaudoux, F., Levasseur, M.-C., Palkovits, M., Blacker, C., & Scholler, R. (1988). Interactions between 17 β -estradiol and the hypothalamo-pituitary β -endorphin system in the regulation of the cyclic LH secretion. *J. Steroid Biochem.* 30, 161–168.
- Kesner, J.S., Wilson, R.C., Kaufman, J.-M., Hotchkiss, J., Chen, Y., Yamamoto, H., Pardo, R.R., & Knobil, E. (1987). Unexpected responses of the hypothalamic gonadotropin-releasing hormone “pulse generator” to physiological estradiol inputs in the absence of the ovary. *Proc. Natl. Acad. Sci. USA* 84, 8745–8749.
- King, D.P., Vitaterna, M.H., Chang, A.M., Dove, W.F., Pinto, L.H., Turek, F.W., & Takahashi, J.S. (1997a). The mouse clock mutation behaves as an antimorph and maps within the W19H deletion, distal of Kit. *Genetics* 146 (3), 1049–1060.
- King, D.P., Zhao, Y., Sangoram, A.M., Wilsbacher, L.D., Tanaka, M., Antoch, M.P., Steeves, T.D., Vitaterna, M.H., Kornhauser, J.M., Lowrey, P.L., Turek, F.W., & Takahashi, J.S. (1977b). Positional cloning of the mouse circadian clock gene. *Cell.* 89 (4), 641–653.
- Klein, D.C. (1978). In: *The Hypothalamus* (Reichlin, S., Baldessarini, R.J., & Martin, J.B., Eds.), pp. 303–327. Raven Press, New York.
- Knobil, E. (1974). On the control of gonadotropin secretion in the Rhesus monkey. *Recent Prog. Horm. Res.* 30, 1–36.
- Knobil, E. (1980). The neuroendocrine control of the menstrual cycle. *Recent Prog. Horm. Res.* 36, 53–58.
- Kovács, K.J., & Mezey, E. (1987). Dexamethasone inhibits corticotropin-releasing factor gene expression in the rat paraventricular nucleus. *Neuroendocrinology* 46, 365–368.
- Kozłowski, G.P., & Les Dees, W. (1984). Immunocytochemistry for LHRH neurons in the arcuate nucleus area of the rat. *J. Histochem. Cytochem.* 32, 83–91.
- Krieger, D.T. (1975). Rhythms of ACTH and corticosteroid secretion in health and disease and their experimental modification. *J. Steroid Biochem.* 6, 785–791.
- Lang, R.E., Unger, T., & Ganten, D. (1987). Atrial natriuretic peptide: A new factor in blood pressure control. *J. Hypertens.* 5, 255–271.
- Legan, S.J., & Karsch, F.J. (1975). A daily signal for the LH surge in the rat. *Endocrinology* 96, 57–62.
- Leong, D.A., Frawley, L.S., & Neill, J.D. (1983). Neuroendocrine control of prolactin secretion. *Ann. Rev. Physiol.* 45, 109–127.
- Leranth, C., MacLuskey, N.J., Shanabrough, M., & Naftolin, F. (1988a). Immunohistochemical evidence for synaptic connections between proopiomelanocortin-immunoreactive axons and LHRH neurons in the preoptic area of the rat. *Brain Res.* 449, 167–176.
- Leranth, C., MacLuskey, N.J., Shanabrough, M., & Naftolin, F. (1988b). Catecholaminergic innervation of luteinizing hormone releasing hormone and glutamic acid decarboxylase immunopositive neurons in the rat medial preoptic area - an electron microscopic double immunostaining and degeneration study. *Neuroendocrinology* 48, 591–602.

- Levine, J.E., & Duffy, M.T. (1988). Simultaneous measurement of luteinizing hormone (LH)-releasing hormone, LH, and follicle-stimulating hormone release in intact and short-term castrated rats. *Endocrinology* 122, 2211–2221.
- Lewis, S. (1992). Sex and schizophrenia: Vive la différence. *Br. J. Psychiatry* 161, 445–450.
- Lewis, C.E., Morris, J.F., & Fink, G. (1985). The role of microfilaments in the priming effect of LH-releasing hormone: an ultrastructural study using cytochalasin B. *J. Endocrinol.* 106, 211–218.
- Lewis, C.E., Morris, J.F., Fink, G., & Johnson, M. (1986). Changes in the granule population of gonadotrophs of hypogonadal (*hpg*) and normal female mice associated with the priming effect of LH-releasing hormone *in vitro*. *J. Endocrinol.* 109, 35–44.
- Leyens, J.E., Janssen, P.M.F., Gommeren, W., Wynants, J., Pauwels, P.J., & Janssen, P.A.J. (1992). *In vitro* and *in vivo* receptor binding and effects on monoamine turnover in rat brain regions of the novel antipsychotics risperidone and ocapiperidone. *Mol. Pharmacol.* 41, 494–508.
- Lightman, S.L., & Harbuz, M.S. (1993). In: *Corticotropin-Releasing Factor*, Ciba Symposium 172, pp. 173–187. John Wiley & Sons, Chichester.
- Lim, A.T., Dow, R., Yang, Z., & Fink, G. (1994). ANP5-28 is the major molecular species in hypophysial portal blood of the rat. *Peptides* 15, 1557–1559.
- Lim, A.T., Sheward, W.J., Copolov, D., Windmill, D., & Fink, G. (1990). Atrial natriuretic factor is released into hypophysial portal blood: direct evidence that atrial natriuretic factor may be a neurohormone involved in hypothalamic pituitary control. *J. Neuroendocrinol.* 2, 15–18.
- Lincoln, G.A., & Short, R.V. (1980). Seasonal breeding: nature's contraceptive. *Recent Prog. Horm. Res.* 36, 1–43.
- Lowry, P.J. (1993). In: *Corticotropin-releasing factor*, Ciba Symposium 172, pp. 108–115. John Wiley & Sons, Chichester.
- Mackinnon, P.C.B., Puig-Duran, E., & Laynes, R. (1978). Reflections on the attainment of puberty in the rat: Have circadian signals a role to play in its onset? *J. Reprod. Fertil.* 52, 401–412.
- Maes, M., Minner, B., Suy, E., D'Hondt, P., Jacobs, M.-P., & Raus, J. (1991). Cortisol escape from suppression by dexamethasone during depression is strongly predicted by basal cortisol hypersecretion and increasing age combined. *Psychoneuroendocrinology* 16, 295–310.
- Maxwell, R.C., & Fink, G. (1988). The connections between the suprachiasmatic, ventrolateral geniculate and raphe nuclei studied by uptake of [¹⁴C]-2-deoxyglucose. *Neuroscience* 24, 265–274.
- McNeilly, A.S. (1987). Prolactin and the control of gonadotrophin secretion. *J. Endocrinol.* 115, 1–5.
- McQueen, J.K., & Fink, G. (1988). Changes in local cerebral glucose utilization associated with the spontaneous ovulatory surge of luteinizing hormone in the rat. *Neuroendocrinology* 47, 551–555.
- McQueen, J.K., Wilson, H., & Fink, G. (1997). Estradiol-17 β increases serotonin transporter (SERT) mRNA levels and the density of SERT binding sites in female rat brain. *Mol. Brain Res.* 45, 13–23.
- Meidan, R., Fink, G., & Koch, Y. (1981). Ontogeny of the sensitizing effect of oestradiol and luteinizing hormone releasing hormone on the anterior pituitary of the female rat. *J. Endocrinol.* 91, 347–351.
- Meijs-Roelofs, H.M.A., Uilenbroek, J.T.J., de Greef, W.J., de Jong, F.H., & Kramer, P. (1975). Gonadotrophin and steroid levels around the time of first ovulation in the rat. *J. Endocrinol.* 67, 275–282.
- Meltzer, H.Y., & Lowry, M.T. (1987). In: *Psychopharmacology: The Third Generation of Progress* (Meltzer, H.Y., Ed.), pp. 513–526. Raven Press, New York.
- Meltzer, H.Y., Matsubara, S., & Lee, J.-C. (1989). Classification of typical and atypical antipsychotic drugs on the basis of dopamine D-1, D-2 and serotonin₂ pK_i values. *J. Pharmacol. Exp. Ther.* 251, 238–246.
- Milhorn, H.T.J. (1966). *The Application of Control Theory to Physiological Systems*, pp. 386. W.B. Saunders Company, Philadelphia.
- Mitchell, R., Johnson, M., Ogier, S.-A., & Fink, G. (1988). Facilitated calcium mobilization and inositol phosphate production in the priming effect of LH-releasing hormone in the rat. *J. Endocrinol.* 119, 293–301.

- Mobbs, C.V., Fink, G., & Pfaff, D.W. (1990a). HIP-70: A protein induced by estrogen in the brain and LH-RH in the pituitary. *Science* 247, 1477–1479.
- Mobbs, C.V., Fink, G., & Pfaff, D.W. (1990b). HIP-70: An isoform of phosphoinositol-specific phospholipase C- α . *Science* 249, 566.
- Mobbs, C.V., Harlan, R.E., Burrows, M.R., & Pfaff, D.W. (1988). An estradiol-induced protein synthesized in the ventral medial hypothalamus and transported to the midbrain central gray. *J. Neurosci.* 8, 113–118.
- Mobbs, C.V., Kaplitt, M., & Pfaff, D.W. (1997). HIP-70/GRP58/ERp61/PLC- α /CPT: a single gene product and member of the protein disulfide isomerase gene family with thiol oxidoreductase activity subject to neuroendocrine regulation (Guzman, N.A., Ed.), "Prolyl hydroxylase." pp. 237–272. Marcel Dekker, New York.
- Moenter, S.M., Caraty, A., & Karsch, F.J. (1990). The estradiol-induced surge of gonadotropin-releasing hormone in the ewe. *Endocrinology* 127, 1375–1384.
- Moore, R.Y. (1978). In: *Frontiers in Neuroendocrinology* (Ganong, W.F., & Martini, L., Eds.), pp. 185–206. Raven Press, New York.
- Morris, J.F., Lewis, C.E., & Fink, G. (1986). In: *Neuroendocrine Molecular Biology* (Fink, G., Harmar, A.J., & McKerns, K.W., Eds.), pp. 341–352, Plenum Press, New York.
- Munck, A., Guyre, P.M., & Holbrook, N.J. (1984). Physiological functions of glucocorticoids in stress and their relation to pharmacological actions. *Endocr. Rev.* 5, 22–44.
- Nauta, W.J.H. (1963). In: *Advances in Neuroendocrinology* (Nalbandov, A.V., Ed.), pp. 5–12. University of Illinois Press, Urbana.
- Neill, J.D., Patton, J.M., Dailey, R.A., Tsou, R.C., & Tindall, G.T. (1977). Luteinizing hormone releasing hormone (LHRH) in pituitary stalk blood of rhesus monkeys: relationship to level of LH release. *Endocrinology* 101, 430–434.
- Nett, J.M., Crowden, M.E., & Wise, M.E. (1984). Role of estradiol in inducing an ovulatory-like surge of luteinizing hormone in sheep. *Biol. Reprod.* 30, 1208–1215.
- Nikolarakis, K.E., Pfeiffer, D.G., Almeida, O.F.X., & Herz, A. (1986). Opioid modulation of LHRH release *in vitro* depends upon levels of testosterone *in vivo*. *Neuroendocrinology* 44, 314–319.
- O'Brien, P.M.S. (1993). Helping women with premenstrual syndrome. *Brit. Med. J.* 307, 1471–1475.
- O'Byrne, K.T., Chen, M.-D., Nishihara, M., Williams, C.L., Thalabard, J.-C., Hotchkiss, J., & Knobil, E. (1993). Ovarian control of gonadotropin hormone-releasing hormone pulse generator activity in the rhesus monkey: duration of the associated hypothalamic signal. *Neuroendocrinology* 57, 588–592.
- Ojeda, S.R., & Urbanski, H.F. (1987). In: *The Physiology of Reproduction* (Knobil, E. & Neill, J., Eds.), pp. 1699–1737, Raven Press, New York.
- Oliver, J.D., van der Wal, F.J., Bulleid, N.J., & High, S. (1977). Interaction of the thiol-dependent reductase ER_p57 with nascent glycoproteins. *Science* 275, 86–88.
- Orth, D.N., Kovacs, W.J., & DeBold, C.R. (1992). In: *Williams Textbook of Endocrinology* (Wilson, J.D., & Foster, D.W., Eds.), pp. 489–619, W.B. Saunders Company, Philadelphia.
- Paterson, J.M., Smith, S.M., Harmar, A.J., & Antoni, F.A. (1995). Control of a novel adenylyl cyclase by calcineurin. *Biochem. Biophys. Res. Commun.* 214, 1000–1008.
- Pfaff, D.W. (1980). *Estrogens and Brain Function*, pp. 281. Springer Verlag, Berlin.
- Pfaff, D.W. (1986). Gene expression in hypothalamic neurons: luteinizing hormone releasing hormone. *J. Neurosci. Res.* 16, 109–115.
- Pickering, A., & Fink, G. (1976). Priming effect of luteinizing hormone releasing factor: *in vitro* and *in vivo* evidence consistent with its dependence upon protein and RNA synthesis. *J. Endocrinol.* 69, 373–379.
- Pickering, A.J.M.C., & Fink, G. (1979a). Priming effect of luteinizing hormone releasing factor *in vitro*: role of protein synthesis, contractile elements, Ca²⁺ and cyclic AMP. *J. Endocrinol.* 81, 223–234.
- Pickering, A.J.M.C., & Fink, G. (1979b). Variation in size of the "readily releasable pool" of luteinizing hormone during the oestrous cycle of the rat. *J. Endocrinol.* 83, 53–59.

- Plotsky, P.M., Otto, S., & Sapolsky, R.M. (1986). Inhibition of immunoreactive corticotropin-releasing factor secretion into the hypophysial-portal circulation by delayed glucocorticoid feedback. *Endocrinology* 119, 1126–1130.
- Plotsky, P.M., & Sawchenko, P.E. (1987). Hypophysial-portal plasma levels, median eminence content, and immunohistochemical staining of corticotropin-releasing factor, arginine vasopressin, and oxytocin after pharmacological adrenalectomy. *Endocrinology* 120, 1361–1369.
- Plotsky, P.M., Sutton, S.W., Bruhn, T.O., & Ferguson, A.V. (1988). Analysis of the role of angiotensin II in mediation of adrenocorticotropin secretion. *Endocrinology* 122, 538–545.
- Raisman, G. (1966). Neural connexions of the hypothalamus. *Br. Med. Bull.* 22, 197–201.
- Raisman, G., & Brown-Grant, K. (1977). The 'suprachiasmatic syndrome': Endocrine and behavioral abnormalities following lesions of the suprachiasmatic nuclei in the female rat. *Proc. R. Soc. Lond. (Biol)* 198, 297–314.
- Rapkin, A.J. (1992). The role of serotonin in premenstrual syndrome. *Clin. Obstet. Gynecol.* 35, 629–636.
- Ratka, A., Sutanto, W., Bloemers, M., & de Kloet, E.R. (1989). On the role of brain mineralocorticoid (Type I) and glucocorticoid (Type II) receptors in neuroendocrine regulation. *Neuroendocrinology* 50, 117–123.
- Reiter, R.J. (1981). The mammalian pineal gland: structure and function. *Am. J. Anat.* 62, 287–313.
- Renfree, M.B. (1981). Marsupials: alternative mammals. *Nature* 293, 100.
- Rethelyi, M., Vigh, S., Setalo, G., Merchenthaler, I., Flerko, B., & Petrusz, P. (1981). The luteinizing hormone releasing hormone-containing pathways and their co-termination with tanocyte processes in and around the median eminence and the pituitary stalk of the rat. *Acta. Morphol. Acad. Sci. Hung.* 29, 259–283.
- Roberts, J.L., Wilcox, J.N., & Blum, M. (1986). In: *Neuroendocrine Molecular Biology* (Fink, G., Harmar, A.J., & McKerns, K.W., Eds.), pp. 261–270, Plenum Press, New York.
- Roselli, C.E., Kelly, M.J., & Ronnekleiv, O.K. (1990). Testosterone regulates progonaotropin-releasing hormone levels in the preoptic area and basal hypothalamus of the male rat. *Endocrinology* 126, 1080–1086.
- Rosie, R., Sumner, B.E.H., & Fink, G. (1994). An $\alpha 1$ adrenergic mechanism mediates estradiol stimulation of LHRH mRNA synthesis and estradiol inhibition of POMC mRNA synthesis in the hypothalamus of the prepubertal female rat. *J. Steroid Biochem. Mol. Biol.* 49, 399–406.
- Rosie, R., Thomson, E., & Fink, G. (1990). Oestrogen positive feedback stimulates the synthesis of LHRH mRNA in neurons of the rostral diencephalon of the rat. *J. Endocrinol.* 124, 285–289.
- Rossmann, W.G., Marks, D.L., Clifton, D.K., & Steiner, R.A. (1994). Induction of galanin gene expression in gonadotropin-releasing hormone neurons with puberty in the rat. *Endocrinology* 135, 1401–1408.
- Rudenstein, R.S., Bigdeli, H., McDonald, M.H., & Snyder, P.J. (1979). Administration of gonadal steroids to the castrated male rat prevents a decrease in the release of gonadotropin-releasing hormone from the incubated hypothalamus. *J. Clin. Invest.* 63, 262–267.
- Sapolsky, R.M. (1992). *Stress, the Aging Brain, and the Mechanisms of Neuron Death*, pp. 429, The MIT Press, Cambridge, MA.
- Sapolsky, R.M., Armanini, M.P., Sutton, S.W., & Plotsky, P.M. (1989). Elevation of hypophysial portal concentrations of adrenocorticotropin secretagogues after fornix transection. *Endocrinology* 125, 2881–2887.
- Sarkar, D.K., Chiappa, S.A., Fink, G., & Sherwood, N.M. (1976). Gonadotropin-releasing hormone surge in pro-oestrous rats. *Nature* 264, 461–463.
- Sarkar, D.K., & Fink, G. (1979a). Mechanism of the first spontaneous gonadotrophin surge and that induced by pregnant mare serum and effects of neonatal androgen in rats. *J. Endocrinol.* 83, 339–354.
- Sarkar, D.K., & Fink, G. (1979b). Effects of gonadal steroids on output of luteinizing hormone releasing factor into pituitary stalk blood in the female rat. *J. Endocrinol.* 80, 303–313.

- Sarkar, D.K., & Fink, G. (1980). Luteinizing hormone releasing factor in pituitary stalk plasma from long-term ovariectomized rats: effects of steroids. *J. Endocrinol.* 86, 511–524.
- Sarkar, D.K., & Fink, G. (1981). Gonadotropin-releasing hormone surge: possible modulation through postsynaptic α -adrenoreceptors and two pharmacologically distinct dopamine receptors. *Endocrinology* 108, 862–867.
- Sarkar, D.K., & Yen, S.S.C. (1985). Changes in β -endorphin-like immunoreactivity in pituitary portal blood during the estrous cycle and after ovariectomy in rats. *Endocrinology* 116, 2075–2079.
- Sawchenko, P.E., & Swanson, L.W. (1983). The organization of forebrain afferents to the paraventricular and supraoptic nuclei of the rat. *J. Comp. Neurol.* 218, 121–144.
- Schally, A.V., Bajusz, S., Redding, T.W., Zalatnai, A., & Comaru-Schally, A.M. (1989). In: *GnRH Analogues in Cancer and Human Reproduction*, Vol. 1, Basic Aspects (Vickery, B.H., & Lunenfeld, B., Eds.), pp. 5–31. Kluwer, Dordrecht.
- Seckl, J.R. (1997). 11β -Hydroxysteroid dehydrogenase in the brain: A novel regulator of glucocorticoid action? *Front. Neuroendocrinol.* 18 (1), 49–99.
- Seckl, J.R., Dow, R.C., Low, S.C., Edwards, C.R.W., & Fink, G. (1993). The 11β -hydroxysteroid dehydrogenase inhibitor glycyrrhetic acid affects corticosteroid feedback regulation of hypothalamic corticotrophin-releasing peptides in rats. *J. Endocrinol.* 136, 471–477.
- Seeman, M.V., & Lang, M. (1990). The role of estrogens in schizophrenia gender differences. *Schizophr. Bull.* 16, 185–195.
- Sherwood, N.M., Chiappa, S.A., & Fink, G. (1976). Immunoreactive luteinizing hormone releasing factor in pituitary stalk blood from female rats: sex steroid modulation of response to electrical stimulation of preoptic area or median eminence. *J. Endocrinol.* 70, 501–511.
- Sherwood, N.M., Chiappa, S.A., Sarkar, D.K., & Fink, G. (1980). Gonadotropin-releasing hormone (GnRH) in pituitary stalk blood from proestrus rats: effects of anesthetics and relationship between stored and released GnRH and luteinizing hormone. *Endocrinology* 107, 1410–1417.
- Sheward, W.J., & Fink, G. (1991). Effects of corticosterone on the secretion of corticotrophin-releasing factor, arginine vasopressin and oxytocin into hypophysial portal blood in long-term hypophysectomized rats. *J. Endocrinol.* 129, 91–98.
- Sheward, W.J., Lim, A., Alder, B., Copolov, D., Dow, R.C., & Fink, G. (1991). Hypothalamic release of atrial natriuretic factor and β -endorphin into rat hypophysial portal plasma: relationship to oestrous cycle and effects of hypophysectomy. *J. Endocrinol.* 131, 113–125.
- Shin, S.H., & Howitt, C. (1975). Effect of castration on luteinizing hormone and luteinizing hormone releasing hormone in the male rat. *J. Endocrinol.* 65, 447–448.
- Shipston, M.J., & Antoni, F.A. (1991). Early glucocorticoid feedback in anterior pituitary corticotrophs: differential inhibition of hormone release induced by vasopressin and corticotrophin-releasing factor *in vitro*. *J. Endocrinol.* 129, 261–268.
- Shipston, M.J., Hernando, F., Barnard, R.J.O., & Antoni, F.A. (1994). Glucocorticoid negative feedback in pituitary corticotrophs: Pivotal role for calcineurin inhibition of adenylyl cyclase. *Ann. N.Y. Acad. Sci.* 746, 453–455.
- Shivers, B.D., Harlan, R.E., Morrell, J.E., & Pfaff, D.W. (1983). Absence of oestradiol concentration in cell nuclei of LHRH-immunoreactive neurones. *Nature* 304, 345–347.
- Silverman, A.J. (1987). In: *The Physiology of Reproduction* (Knobil, E., & Neill, J., Eds.), pp. 1283–1304. Raven Press, New York.
- Simpson, J., Johnson, M.S., & Mitchell, R. (1993). H7-resistant protein kinase C substrates in two-dimensional gels of proestrus rat anterior pituitary gland. *Biochim. Biophys. Acta.* 1220, 69–75.
- Speight, A., & Fink, G. (1981). Changes in responsiveness of dispersed pituitary cells to luteinizing hormone releasing hormone at different times of the oestrous cycle of the rat. *J. Endocrinol.* 89, 129–134.

- Speight, A., Popkin, R., Watts, A.G., & Fink, G. (1981). Oestradiol-17 β increases pituitary responsiveness by a mechanism that involves the release and the priming effect of luteinizing hormone releasing factor. *J. Endocrinol.* 88, 301–308.
- Stanley, H.F., Curtis, A., Sheward, W.J., Roberts, J.L., & Fink, G. (1986). Prolactin messenger ribonucleic acid levels in the normal and hypogonadal mouse pituitary gland. *Endocrinology* 119, 2422–2426.
- Steinberger, A., & Ward, D.N. (1987). In: *The Physiology of Reproduction* (Knobil, E., & Neill, J.D., Eds.), pp. 567–583. Raven Press, New York.
- Steiner, R.A., Bremner, W.J., & Clifton, D.K. (1982). Regulation of luteinizing hormone pulse frequency and amplitude by testosterone in the adult male rat. *Endocrinology* 111, 2055–2061.
- Sumner, B.E.H., & Fink, G. (1993). Effects of acute estradiol on 5-hydroxytryptamine and dopamine receptor subtype mRNA expression in female rat brain. *Mol. Cell. Neurosci.* 4, 83–92.
- Sumner, B.E.H., & Fink, G. (1995). Estrogen increases the density of 5-HT_{2A} receptors in cerebral cortex and nucleus accumbens in the female rat. *J. Steroid. Biochem. Molec. Biol.* 54, 15–20.
- Swanson, L.W., & Simmons, D.M. (1989). Differential steroid hormone and neural influences on peptide mRNA levels in CRH cells of the paraventricular nucleus: A hybridization histochemical study in the rat. *J. Comp. Neurol.* 285, 413–435.
- Szafarczyk, A., Alonso, G., Ixart, G., Malaval, F., Nouguiere-Soule, J., & Assenmacher, I. (1980). Serotonergic system and circadian rhythms of ACTH and corticosterone in rats. *Am. J. Physiol.* 239, E482–E489.
- Tannahill, L.A., Sheward, W.J., Robinson, I.C.A.F., & Fink, G. (1991). Corticotrophin-releasing factor-41, vasopressin and oxytocin release into hypophysial portal blood in the rat: effects of electrical stimulation of the hypothalamus, amygdala and hippocampus. *J. Endocrinol.* 129, 99–107.
- Tansey, E.M., Arbutnot, G.W., Fink, G., & Whale, D. (1983). Oestradiol-17 β increases the firing rate of antidromically identified neurones of the rat neostriatum. *Neuroendocrinology* 37, 106–110.
- Taylor, A.D., Cowell, A.-M., Flower, J., & Buckingham, J.C. (1993). Lipocortin I mediates an early inhibitory action of glucocorticoids on the secretion of ACTH by the rat anterior pituitary gland in vitro. *Neuroendocrinology* 58, 430–439.
- Therrien, M., & Drouin, J. (1993a). Molecular determinants for cell specificity and glucocorticoid repression of the proopiomelanocortin. *Ann. N.Y. Acad. Sci.* 680, 663–671.
- Therrien, M., & Drouin, J. (1993b). Cell-specific helix-loop-helix factor required for pituitary expression of the proopiomelanocortin gene. *Mol. Cell. Biol.* 13, 2342–2353.
- Thompson, E.B. (1994). Apoptosis and steroid hormones. *Mol. Endocrinol.* 8, 665–673.
- Tremblay, Y., Tretjakoff, I., Peterson, A., Antakly, T., Zhang, C.X., & Drouin, J. (1988). Pituitary-specific expression and glucocorticoid regulation of a proopiomelanocortin fusion gene in transgenic mice. *Proc. Natl. Acad. Sci. USA* 85, 8890–8894.
- Turgeon, J.L., & Barraclough, C.A. (1974). In: *Endocrinologie Sexuelle de la Periode Perinatale* (Forrest, M.G. & Bertrand, J., Eds.), pp. 339–356. INSERM, Paris.
- Turgeon, J.L., & Waring, D.W. (1981). Acute progesterone and 17 β -estradiol modulation of luteinizing hormone secretion by pituitaries of cycling rats superfused *in vitro*. *Endocrinology* 108, 413–419.
- Turgeon, J.L., & Waring, D.W. (1992). Functional cross-talk between receptors for peptide and steroid hormones. *Trends Endocrinol. Metab.* 3, 360–365.
- Turgeon, J.L., & Waring, D.W. (1994). Activation of the progesterone receptor by the gonadotropin-releasing hormone self-priming signaling pathway. *Mol. Endocrinol.* 6, 860–869.
- Vamvakopoulos, N.C., & Chrousos, G.P. (1994). Hormonal regulation of human corticotropin-releasing hormone gene expression: implications for the stress response and immune/inflammatory reaction. *Endocr. Rev.* 15, 409–420.
- van der Beek, E.M., van Oudheusden, H.J.C., Buijs, R.M., van der Donk, H.A., van den Hurk, R., & Wiegant, V.M. (1994). Preferential induction of *c-fos* immunoreactivity in vasoactive intestinal

- polypeptide-innervated gonadotropin-releasing hormone neurons during a steroid-induced luteinizing hormone surge in the female rat. *Endocrinology* 134, 2636–2644.
- Versi, E., Chiappa, S.A., Fink, G., & Charlton, H.M. (1983). Pineal influences hypothalamic Gn-RH content in the vole, *Microtus agrestis*. *J. Reprod. Fertil.* 67, 365–368.
- Vilchez-Martinez, J.A., Arimura, A., Debeljink, L., & Schally, A.V. (1974). Biphasic effect of estradiol benzoate on the pituitary responsiveness to LHRH. *Endocrinology* 94, 1300–1303.
- Vitaterna, M.H., King, D.P., Chang, A.M., Kornhauser, J.M., Lowrey, P.L., McDonald, J.D., Dove, W.F., Pinto, L.H., Turek, F.W., & Takahashi, J.S. (1994). Mutagenesis and mapping of a mouse gene, clock, essential for circadian behavior. *Science* 264 (5159), 719–725.
- Waldhauser, F., Boepple, P.A., & Crowley Jr., W.F. (1993). In: *Sexual Precocity: Etiology, Diagnosis, and Management* (Grave, G.D., & Cutler Jr, G.B., Eds.), pp. 181–192. Raven Press, New York.
- Wang, C.F., Lasley, B.L., Lein, A., & Yen, S.S.C. (1976). The functional changes of the pituitary gonadotrophs during the menstrual cycle. *J. Clin. Endocrinol. Metab.* 42, 718–728.
- Wardlaw, S.L., Wehrenberg, W.B., Ferin, M., Antunes, J.L., & Frantz, A.G. (1982). Effect of sex steroids on β -endorphin in hypophyseal portal blood. *J. Clin. Endocrinol. Metab.* 55, 877–881.
- Waring, D.W., & Turgeon, J.L. (1980). Luteinizing hormone-releasing hormone-induced luteinizing hormone secretion *in vitro*: Cyclic changes in responsiveness and self-priming. *Endocrinology* 106, 1430–1436.
- Watts, A.G., Sheward, W.J., Whale, D., & Fink, G. (1989). The effects of knife cuts in the sub-paraventricular zone of the female rat hypothalamus on oestrogen-induced diurnal surges of plasma prolactin and LH, and circadian wheel-running activity. *J. Endocrinol.* 122, 593–604.
- Weesner, G.D., Bergen, H.T., & Pfaff, D.W. (1992). Differential regulation of luteinizing hormone-releasing hormone and galanin messenger ribonucleic acid levels by α_1 -adrenergic agents in the ovariectomized rat. *J. Neuroendocrinol.* 4, 331–336.
- Weesner, G.D., Krey, L.C., & Pfaff, D.W. (1993). α_1 Adrenergic regulation of estrogen-induced increases in luteinizing hormone-releasing hormone mRNA levels and release. *Mol. Brain Res.* 17, 77–82.
- Wehrenberg, W.B., Wardlaw, S.L., Frantz, A.G., & Ferin, M. (1982). β -endorphin in hypophyseal portal blood: variations throughout the menstrual cycle. *Endocrinology* 111, 879–811.
- Weiner, R.I., Findell, P.R., & Kordon, C. (1988). In: *The Physiology of Reproduction* (Knobil, E. & Neill, J., Eds.), pp. 1235–1281. Raven Press, New York.
- Wetsel, W.C., & Negro-Vilar, A. (1989). Testosterone selectively influences protein kinase-C-coupled secretion of proluteinizing hormone-releasing hormone-derived peptides. *Endocrinology* 125, 538–547.
- Whalley, L.J., Borthwick, N., Copolov, D., Dick, H., Christie, J.E., & Fink, G. (1986). Glucocorticoid receptors and depression. *Brit. Med. J.* 292, 859–861.
- White, P.C., Curnow, K.M., & Pascoe, L. (1994). Disorders of steroid 11 β -hydroxylase isozymes. *Endocr. Rev.* 15, 421–438.
- Wieck, A., Kumar, R., Hirst, A.D., Marks, M.N. Campbell, I.C., & Checkley, S.A. (1991). Increased sensitivity of dopamine receptors and recurrence of affective psychosis after childbirth. *Brit. Med. J.* 303, 613–616.
- Williams, C.L., Nishihara, M., Thalabard, J.-C., O'Byrne, K.T., Grosser, P.M., Hotchkiss, J., & Knobil, E. (1990). Duration and frequency of multiunit electrical activity associated with the hypothalamic gonadotropin releasing hormone pulse generator in the rhesus monkey: differential effects of morphine. *Neuroendocrinology* 52, 225–228.
- Wise, P.M., Scarbrough, K., Weiland, N.G., & Larson, G.H. (1990). Diurnal pattern of proopiomelanocortin gene expression in the arcuate nucleus of proestrous, ovariectomized, and steroid-treated rats: a possible role in cyclic luteinizing hormone secretion. *Mol. Endocrinol.* 4, 886–892.
- Woller, M.J., & Terasawa, E. (1994). Changes in pulsatile release of neuropeptide-Y and luteinizing hormone (LH)-releasing hormone during the progesterone-induced LH surge in rhesus monkeys. *Endocrinology* 135, 1679–1686.

- Wood, S.H., Mortola, J.F., Chan, Y.F., Moossazadeh, F., & Yen, S.S.C. (1992). Treatment of premenstrual syndrome with fluoxetine: a double-blind, placebo-controlled, crossover study. *Obstet. Gynecol.* 80, 339–344.
- Wu, J.C., Sealfon, S.C., & Miller, W.L. (1994). Gonadal hormones and gonadotropin-releasing hormone (GnRH) alter messenger ribonucleic acid levels for GnRH receptors in sheep. *Endocrinology* 134, 1846–1850.
- Yates, F.E., & Maran, J.W. (1975). In: *Handbook of Physiology* (Knobil, E., & Sawyer, W.H., Eds.), pp. 367–404. American Physiological Society, Washington DC.
- Yen, S.S.C., Lasley, B.L., Wang, C.F., Leblane, H., & Siler, T.M. (1975). The operating characteristics of the hypothalamic pituitary system during the menstrual cycle and observations of biological action of somatostatin. *Recent Prog. Horm. Res.* 31, 321–357.
- Yen, S.S.C., Tsai, C.C., Naftolin, F., Van den Berg, G., & Ajabor, L. (1972). Pulsatile patterns of gonadotropin release in subjects with and without ovarian function. *J. Clin. Endocrinol. Metab.* 34, 671–675.
- Yeoman, R.R., & Terasawa, E. (1984). An increase in single unit activity of the medial basal hypothalamus occurs during the progesterone-induced luteinizing hormone surge in the female rhesus monkey. *Endocrinology* 115, 2445–2452.
- Young, D.A., Kotun, J., Haskett, R.F., Grunhaus, L., Greden, J.F., Watson, S.J., & Akil, H. (1993). Dissociation between pituitary and adrenal suppression to dexamethasone in depression. *Arch. Gen. Psychiatry* 50, 395–403.
- Young, W.S.I., & Kuhar, M.J. (1980). Noradrenergic $\alpha 1$ and $\alpha 2$ receptors: light microscopic autoradiographic localization. *Proc. Natl. Acad. Sci. USA* 77, 1969–1970.
- Zifa, E., & Fillion, G. (1992). 5-hydroxytryptamine receptors. *Pharmacol. Rev.* 44, 401–458.

Chapter 3

Corticotropin-Releasing Hormone Neurosecretory Cells

REGULATION OF PEPTIDE EXPRESSION AND RELEASE

MARK H. WHITNALL

Introduction	102
The Hypothalamo–Pituitary–Adrenal Axis	102
The Stress Response	102
The Diurnal Rhythm	108
Regulation of Peptide Expression in Hypothalamic Neurosecretory Cells	108
Corticotropin-Releasing Hormone (CRH)	109
Vasopressin (VP)	109
Regulation of Peptide Release from Neurosecretory Axons	110
Glucocorticoids and the Limbic System	110
Catecholamine Inputs from the Brain Stem	111
Cytokines	111
Serotonin Input from Midbrain Raphe Nuclei	111
Histamine	111

Principles of Medical Biology, Volume 10A
Molecular and Cellular Endocrinology, pages 101–117.
Copyright © 1997 by JAI Press Inc.
All rights of reproduction in any form reserved.
ISBN: 1-55938-815-3

Acetylcholine	112
Opioids	112
Lipid-Derived Autacoids	112
Summary	112

INTRODUCTION

The hypothalamo–pituitary–adrenal (HPA) axis is thought to promote survival during severe physical challenges such as hemorrhage, hypothermia, and infection. However, the actual neuroendocrine mechanisms that promote recovery *in vivo* are very poorly understood, in part due to deemphasis of this question in research over the last 30 years. The following information on the organization of the HPA axis is offered in the hope of providing clues to the development of clinically relevant treatments.

THE HYPOTHALOMO–PITUITARY–ADRENAL AXIS

The HPA axis consists of three components (Figures 1 and 2): (1) neurosecretory cells in the paraventricular nucleus of the hypothalamus that release the peptides—corticotropin-releasing hormone (CRH) and vasopressin (VP) (Whitnall, 1993), (2) corticotrope cells in the anterior lobe of the pituitary gland that respond to CRH and VP by secreting the peptide hormone ACTH (Antoni, 1986), and (3) the ACTH-responsive layers of the adrenal cortex that synthesize and release the class of steroid hormones known as glucocorticoids (primarily cortisol in humans, corticosterone in rats) (Vinson et al., 1992). The name “glucocorticoids” arose from the effects of these steroids on glucose metabolism, but they also have effects on the cardiovascular system, immune system, inflammatory processes, and many other processes throughout the body (Vinson et al., 1992). CRH neurosecretory cells are termed “parvocellular” to indicate that they are smaller in size than the “magnocellular” neurosecretory cells that project axons to the posterior lobe of the pituitary (Figure 2). The CRH neurosecretory axons terminate in the external zone of the median eminence. CRH and VP reach the corticotrope cells by means of a specialized portal capillary system that extends between the external zone of the median eminence and the anterior lobe of the pituitary gland (Figure 2). In rats and humans, the CRH neurosecretory system is divided into a subpopulation of cells that contain coexistent VP (CRH+/VP+ cells) and a VP-deficient subpopulation (CRH+/VP– cells) (Raadsheer et al., 1993; Whitnall, 1993) (Figures 1 and 3).

The Stress Response

Plasma levels of ACTH and glucocorticoids increase markedly during any kind of physical or emotional perturbation, leading to the hypothesis that these hormone

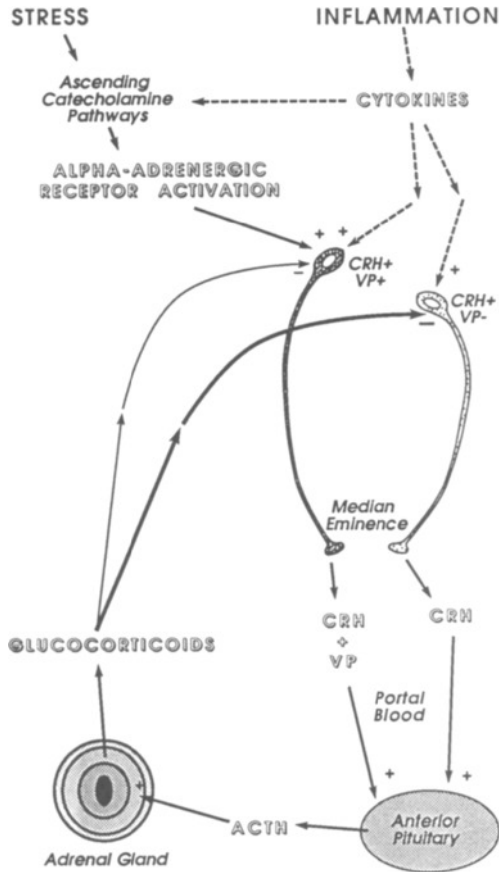

Figure 1. The rat hypothalamo-pituitary-adrenal axis. +: Stimulation. -: Inhibition. CRH+/VP+: VP-containing CRH neurosecretory cell. CRH+/VP-: VP-deficient CRH neurosecretory cell. The different thickness of the arrows representing glucocorticoid inhibition of the neurosecretory cells indicates stronger inhibition of the VP-deficient subpopulation. These arrows are broken to indicate that intermediary glucocorticoid-responsive structures (primarily the limbic system) mediate much of the inhibition. The dashed lines in the inflammatory pathway indicate multiple cytokine sources and targets and uncertainty as to which sources and targets are primary in activating HPA function. [Adapted from Whitnall (1993)].

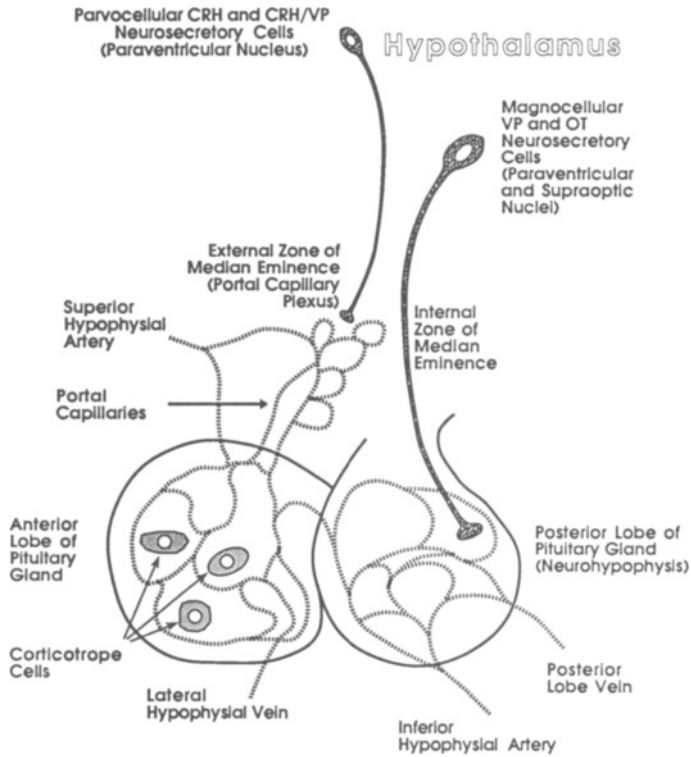

Figure 2. Relationships between parvocellular CRH neurosecretory cells, magnocellular hypothalamo–neurohypophysial neurosecretory cells, the portal capillary system, and corticotrope cells of the anterior lobe of the pituitary gland. [Adapted from Whitnall (1993)].

responses are part of a generalized defense against many types of challenges (Selye, 1976). This hypothesis was tested by manipulating levels of glucocorticoids during major surgical stress, and it was found that above normal levels of glucocorticoids conferred no detectable advantage (Whitnall, 1993). However, it would be prudent to assume that the highly predictable increases in glucocorticoids that occur in response to any kind of stress have some adaptive value, perhaps related to their effects on energy metabolism or cardiovascular tone (Vinson et al., 1992). Bilateral adrenalectomy reduces glucocorticoids to extremely low levels, and causes animals to die in response to challenges that would not normally be life-threatening. However, this is irrelevant to the question of whether increasing glucocorticoid levels over normal values promotes survival during severe challenges. Totally eliminating circulating glucocorticoids has wide-ranging deleterious consequences that produce a very abnormal state.

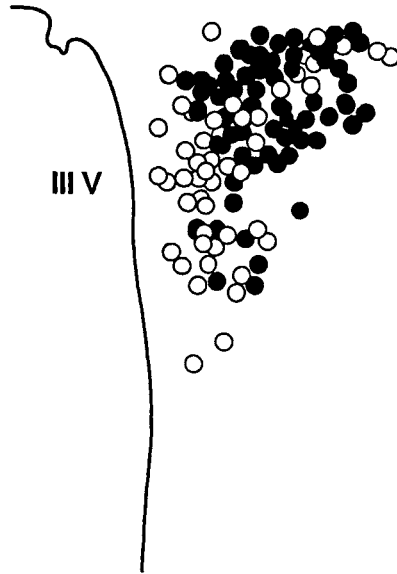

Figure 3. Distinct distributions of parvocellular CRH+/VP+ (filled circles) and CRH+/VP- (open circles) neurosecretory cells in the paraventricular nucleus of the rat hypothalamus. III V: Third Ventricle. [Adapted from Whitnall (1993)].

In the case of inflammation, several groups have provided direct evidence that robust glucocorticoid elevations are necessary to prevent the onset of set of severe autoimmune disorders (Schauenstein et al., 1987; Bolton and Flower, 1989; MacPhee et al., 1989; Takasu et al., 1990; Sternberg, 1992). Inflammatory and immune processes are inhibited at many levels by increases in circulating glucocorticoids (Sternberg, 1992). This fits with a hypothesis put forward by Munck (1984) that many of the reactions of the body to stress can be dangerous if allowed to proceed unchecked, and that the function of the glucocorticoid response is to inhibit these reactions.

Abnormal regulation of the HPA axis has also been implicated as being involved in the etiology of melancholic depression, a psychiatric disorder characterized by painful arousal, hyposomnia, anorexia, and hypercortisolemia (Gold et al., 1988). Several lines of evidence point to chronic hypersecretion of central catecholamines and CRH in depressed patients (Gold et al., 1988). Long-term treatment with antidepressant drugs decreases gene expression of CRH in the paraventricular nucleus (Brady et al., 1991; Brady et al., 1992) (Figure 4).

The presence of VP in portal capillary plasma results in a stronger ACTH response than what would be obtained with CRH alone, because of the synergistic action of CRH and VP in inducing release of ACTH (Antoni, 1986) (Figure 5). The potentiation of the ACTH response to CRH by VP means that small changes in VP

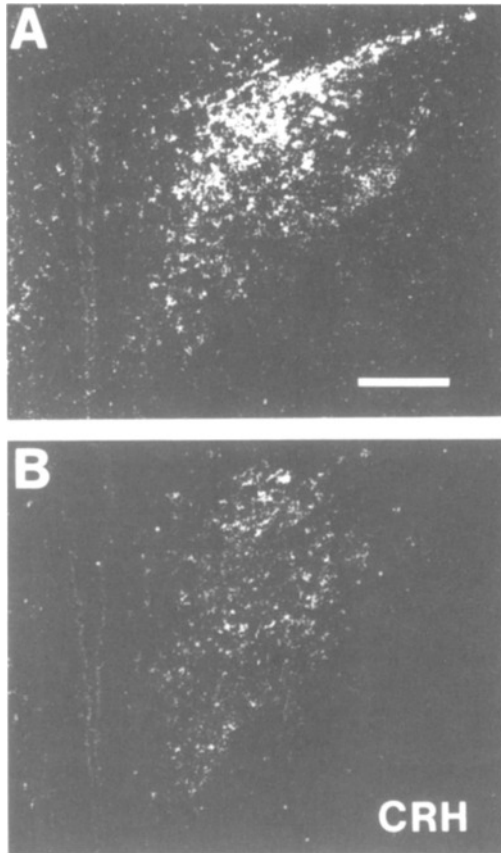

Figure 4. Long term treatment with antidepressant drugs (imipramine in this case) decreases CRH gene expression. Darkfield photomicrographs show radioactive oligonucleotide probe specific for CRH mRNA hybridized to coronal tissue sections through the rat paraventricular nucleus. (A) control rat. (B) 8-week imipramine-treated rat. Bar: 350 μ m. [Reprinted from Brady et al. (1991) with permission of the authors].

concentration can have significant effects on the ACTH response to a stimulus. In addition to potentiating a single ACTH response, VP enables the HPA axis to maintain robust responses during repeated or chronic stimuli (Hashimoto et al., 1988; Scaccianoce et al., 1992). Hence, the sustained HPA responses to repeated inflammatory signals (Mefford et al., 1991; Mengozzi and Ghezzi, 1991; Sweep et al., 1992) can be explained by the fact that cytokines induce release of both VP and CRH into portal plasma (Whitnall et al., 1992a,b).

In rats, CRH and VP are copackaged into the same secretory vesicles in the CRH+/VP+ subpopulation, meaning that they are probably co-released (Figure 6). However, modulation of the ratio of released VP to CRH is accomplished by the

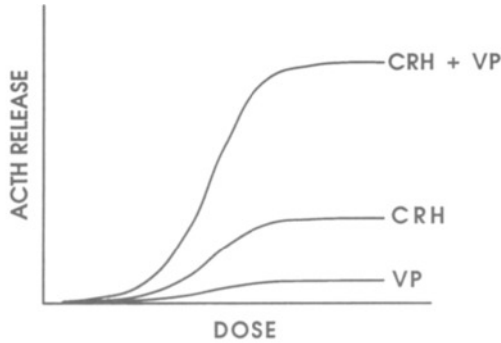

Figure 5. Schematic depiction of the synergism between CRH and VP in inducing release of ACTH from pituitary corticotrope cells. [Reprinted from Whitnall (1993)].

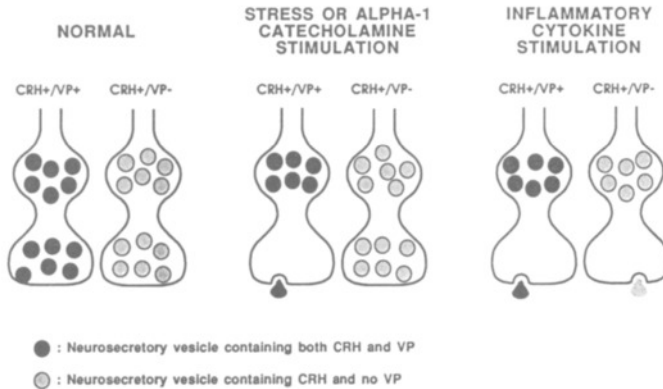

Figure 6. Depletion of neurosecretory vesicles from parvocellular neurosecretory axons in the external zone of the median eminence during different types of stimulation of the HPA axis. In normal rats, there are approximately equal numbers of axonal swellings containing CRH+/VP+ secretory vesicles and CRH+/VP- neurosecretory vesicles. During stress or activation by central alpha-1 catecholamine receptors, many of the CRH+/VP+ axonal swellings become totally depleted of vesicles, with no release of vesicle contents from the CRH+/VP- axonal subpopulation. During inflammatory stimulation by bacterial lipopolysaccharide (endotoxin), which induces cytokines, or by direct administration of cytokines, axonal swellings in both subpopulations become depleted of vesicles. Cytokines activate mechanisms that are different from those activated by stress or catecholamines in stimulating exocytosis of vesicles from neurosecretory axon terminals.

fact that the two subpopulations are differentially activated in different physiological conditions (Whitnall, 1989; Whitnall et al., 1992a,b, Whitnall et al., 1993) (Figure 6). After a period of chronic stress, many of the formerly VP-deficient CRH axons contain VP, allowing for a more robust, habituation-resistant ACTH response to a novel stimulus (de Goeij et al., 1991).

The Diurnal Rhythm

Plasma ACTH and glucocorticoids peak at the onset of the active period during each 24-hour cycle; i.e., in the early morning for humans and in the early evening for nocturnal mammals such as rodents (Krieger, 1979). At the low point of the cycle, stress produces a larger ACTH response than at the peak of the cycle. This difference is not due to the absence of glucocorticoid feedback inhibition at the nadir of the cycle, but is apparently due to other inputs affecting CRH neurosecretory cell responsiveness (Bradbury et al., 1991). The diurnal rhythm of HPA activity (like other circadian rhythms) depends on the integrity of the suprachiasmatic nucleus, which inhibits the CRH neurosecretory system (Whitnall, 1993).

REGULATION OF PEPTIDE EXPRESSION IN HYPOTHALAMIC NEUROSECRETORY CELLS

Peptide expression in neurosecretory cells can be measured in terms of transcription by assaying mRNA levels, or in terms of translation, by measuring peptide levels. Solution hybridization assays of mRNAs or radioimmunoassays of peptides are performed on tissue specimens containing the paraventricular nucleus, and are capable of a high degree of quantitative precision, but suffer from not being able to specifically study parvocellular CRH neurosecretory cells as opposed to other elements within the specimen containing the peptides being measured. *In situ* hybridization and immunocytochemistry can be used to visualize specific mRNAs or peptides, respectively, in identified cells in tissue sections (see Figure 4). Stimulation of peptide expression is sometimes used as evidence of stimulation of release, but such interpretations must be made with caution: changes in perikaryal content of mRNA or peptide are not always correlated with changes in release (Sternberg et al., 1989; Watt and Swanson, 1989; Schilling et al., 1991; Robinson et al., 1992; Watts, 1992).

Regulation of expression of the CRH and VP genes is mediated by intracellular factors that bind to *cis*-regulatory regions in these genes. Two examples of such factors are: (1) proteins that are activated by increases in cyclic AMP (cAMP) and bind to cAMP-responsive elements (CREs) in genes, (2) intracellular steroid hormone receptors that bind to specific gene elements, e.g., glucocorticoid-responsive elements (GREs). Binding takes place in the form of complex networks of factors that interact with DNA. Different factors influence each others' ability to

affect DNA transcription in sometimes unpredictable ways. Hence, the effect of a specific intracellular factor depends on the specific mix of other intracellular factors present within a cell, which is dependent upon the cell type, its state of differentiation, and what types of stimuli the cell is being exposed to. Conclusions about the effect of a specific second messenger or transcription factor on a gene in a certain cell type can not be extrapolated with certainty to other cell types, or even to the same cell type in a different state of differentiation or activation.

Corticotropin-Releasing Hormone (CRH)

The 41-amino acid peptide CRH is expressed in the parvocellular neurosecretory cells and in other cell populations in the hypothalamus and elsewhere. Stress (Silverman et al., 1989), glucocorticoids (Jingami et al., 1985; Herman et al., 1992; Majzoub et al., 1993), and a number of regulatory inputs cause changes in CRH expression in the neurosecretory cells (Whitnall, 1993). In cases where the changes are consistent with changes in release, these inputs will be discussed in the section on regulation of peptide release (see below). A number of *cis*-regulatory sequences have been identified in mammalian CRH genes, including CREs, GREs, and AP-1 sites (which bind to the *fos* and *jun* families of transcription factors) (Whitnall, 1993). The primary second messenger systems that regulate the CRH gene are protein kinase A (activated by increases in intracellular cAMP) and protein kinase C (activated by phorbol esters) (Majzoub et al., 1993). Although glucocorticoids inhibit CRH gene expression in the parvocellular neurosecretory system, they stimulate expression in cultured trophoblast cells obtained from human placenta (Majzoub et al., 1993).

Vasopressin (VP)

As mentioned above, the ratio of VP content to CRH content increases in CRH neurosecretory cells during chronic stress (de Goeij et al., 1991). The expression of VP is more labile than that of CRH, as also indicated by its more profound inhibition by glucocorticoids (Young et al., 1986a,b; Whitnall, 1988). At this point, it is not known what features of the CRH and VP genes cause them to respond differently to the intracellular environments of the CRH neurosecretory cells. Although cAMP generally stimulates expression of CRH and VP genes, and glucocorticoids generally inhibit their expression, these two intracellular signals can interact in an interesting way in the regulation of VP expression. In human small cell lung carcinoma cells, glucocorticoids alone suppress VP expression, but when VP expression is stimulated by cAMP, glucocorticoids produce a further increase (Verbeek et al., 1991).

REGULATION OF PEPTIDE RELEASE FROM NEUROSECRETORY AXONS

Because of the inaccessibility of the portal capillary system, much of the literature on regulation of peptide release from parvocellular neurosecretory cells is based on evidence that is indirect and subject to differing interpretations. Measurement of CRH in peripheral plasma does not reflect hypothalamo–pituitary activity (von Werder and Müller, 1993), and assaying release of VP from parvocellular neurosecretory cells has proven to be problematical because of contamination from the magnocellular hypothalamo–neurohypophysial system (Whitnall, 1993). However, for many regulatory inputs, evidence from the various indirect approaches points in similar directions, and the conclusions are consistent with responses in circulating ACTH and glucocorticoids. Moreover, several groups have adopted the approach of directly assaying peptide depletion from the median eminence using immunocytochemistry, which allows direct measurement of release of CRH and VP from parvocellular neurosecretory axons (Figure 6). In this chapter, the effects of specific inputs will be summarized where a strong consensus has emerged.

Glucocorticoids and the Limbic System

Glucocorticoids exert a strong negative influence on expression and release of CRH and VP to a large extent by acting on limbic circuits, but probably also by acting directly on the neurosecretory cells (Whitnall, 1993). Chronic hypercortisolemia or glucocorticoid treatment results in a profound, long-lasting depression of CRH neurosecretory cells and HPA function (Calogero et al., 1990).

Much of the feedback inhibition of circulating glucocorticoids on the HPA axis is exerted via glucocorticoid-responsive elements in the limbic system (Sapolsky et al., 1984; Whitnall, 1993). There are two types of intracellular glucocorticoid receptors in the brain: the high affinity type I receptors and the low affinity type II receptors. Although the type II receptors are found in many cell types in the brain (and elsewhere), type I receptors in the brain are located predominantly in the limbic system, especially in the hippocampus and lateral septum (Reul and DeKloet, 1985). Receptors for the cytokine interleukin-1 are also concentrated in the hippocampus, and there is some evidence that one of the effects of interleukin-1 is to oppose the actions of glucocorticoids (Whitnall, 1993).

The limbic system has long been known to regulate hypothalamic–pituitary function, with the hippocampus exerting a predominantly inhibitory influence (Endröczy et al., 1959; Knigge and Hays, 1963; Feldman and Saphier, 1989; Herman et al., 1989; Sapolsky et al., 1991). Inhibition from the septal area has also been reported (Endröczy and Lissak, 1963; Kovács and Makara, 1988), while inputs from the amygdala most often appear to be excitatory (Knigge and Hays, 1963; Van de Kar et al., 1991). However, some studies report inhibitory effects from the amygdala or stimulatory effects from the hippocampus, indicating that limbic

structures are too complex to be categorized as simply excitatory or stimulatory to the HPA axis (Dunn and Orr, 1984).

Catecholamine Inputs from the Brain Stem

Catecholaminergic cells in the brain stem project axons to the paraventricular nucleus (Carlsson et al., 1962; Cunningham and Sawchenko, 1988) and play an important role in stimulating CRH neurosecretory cells during stress (Assenmacher et al., 1989; Kiss and Aguilera, 1992). Both noradrenergic and adrenergic cell groups innervate the parvocellular area of the paraventricular nucleus (Swanson et al., 1981; Sawchenko et al., 1985). Alpha-1 catecholamine receptors stimulate release of both CRH and VP into the portal capillary system (Kiss and Aguilera, 1992; Whitnall et al., 1993), and alpha-1-stimulated ACTH responses require the presence of VP (Al-Damluji, 1993). In rats, alpha-1 receptors selectively activate the VP-containing subpopulation of CRH neurosecretory cells with a pattern identical to that of noninflammatory stressors (Whitnall et al., 1993) (see Figures 1, 6).

Cytokines

As discussed above, the HPA axis represents an important negative feedback loop for the inflammatory response. The three primary inflammatory cytokines, interleukin-1, interleukin-6, and tumor necrosis factor, synergistically activate HPA function, with interleukin-6 playing a central role in mediating the response to inflammation (Perlstein et al., 1993). There are clear effects of cytokines at the hypothalamic level, but all of the cytokine sources and cellular targets involved in activation of the HPA are not well defined at present (Whitnall, 1993). Inflammatory cytokines activate both subpopulations of CRH neurosecretory cells in rats (Whitnall et al., 1992 a, b)(Figures 1, 6). Studies have implicated catecholamines as mediating HPA activation by cytokines (Whitnall, 1993) (Figure 1), but since catecholamines selectively stimulate the CRH+/VP+ subpopulation (Whitnall et al., 1993), an additional mechanism must be involved in activating the CRH+/VP- subpopulation.

Serotonin Input from Midbrain Raphe Nuclei

Serotonergic cell groups in the midbrain project axons to the CRH neurosecretory cells which stimulate release of CRH (Whitnall, 1993). Serotonin stimulates activity of the HPA axis via both 5HT₁ and 5HT₂ serotonin receptors (Whitnall, 1993).

Histamine

Intracerebroventricular injection of histamine induces release of ACTH into the circulation, and this increase can be prevented by administering antisera or antagonists to CRH or VP (Kjær et al., 1992; Kjær et al., 1993b; Kjær et al., 1993c). ACTH

responses to stress can be inhibited by blocking central histamine receptors (Knigge et al., 1989; Kjær et al., 1993a), indicating that hypothalamic histamine is involved in activating CRH neurosecretory cells during stress.

Acetylcholine

The HPA axis can be activated by both muscarinic and nicotinic cholinergic agonists, and by inhibition of acetylcholinesterase. *In vitro* studies have shown that cholinergic agonists directly induce release of ACTH secretagogues from the hypothalamus (Whitnall, 1993).

Opioids

The effects of opioids on the HPA axis are consistently inhibitory in human studies, while stimulatory effects are often seen in rats (Whitnall, 1993). However, opioids inhibit the levels of CRH released from transected infundibular stalks in rats (Plotsky, 1986), and also inhibit release of CRH from rat hypothalamus *in vitro* (Grossman et al., 1993), via mu and kappa but not delta opioid receptors.

Lipid-Derived Autacoids

During many types of cell activation, local hormones (autacoids) are produced in the target cells from membrane phospholipids. One pathway is ubiquitous and leads to arachidonic acid and thence to the eicosanoids; the other pathway is present in circulating leukocytes, platelets, and endothelial cells, and leads to platelet-activating factor (Campbell, 1990). Arachidonic acid is metabolized by either lipoxygenase (to produce leukotrienes and other active products), or by cyclooxygenase, which leads to thromboxane and the prostaglandins (Campbell, 1990). All of the classes of lipid-derived autacoids have been found to stimulate release of CRH (Whitnall, 1993).

SUMMARY

Elevations of circulating glucocorticoids that occur during every type of challenge to homeostasis are mediated by the HPA axis, and are important in controlling inflammatory responses. A multiplicity of neural and hormonal signals are integrated by the hypothalamic CRH neurosecretory system to regulate HPA function. CRH neurosecretory cells secrete the releasing factors CRH and VP, which induce secretion of ACTH from the pituitary gland. Circulating ACTH stimulates release of glucocorticoids from the adrenal cortex. Glucocorticoids regulate functions in every tissue of the body. HPA function is inhibited by glucocorticoids in a negative feedback loop. The strength of the HPA response and its resistance to habituation can be modulated by altering the ratio of VP to CRH in the portal capillary system. This ratio can be altered by differential activation of VP-containing and

VP-deficient subpopulations of CRH neurosecretory cells, or by altering the relative rates of synthesis of CRH and VP in the neurosecretory cells. Important stimulatory inputs to the CRH neurosecretory system are catecholamine projections from the brainstem that mediate the HPA response to stress, and cytokines originating from the immune system. These two inputs utilize different mechanisms to stimulate the HPA axis.

REFERENCES

- Al-Damluji, S. (1993). Adrenergic control of the secretion of anterior pituitary hormones. *Baillière's Clin. Endocrinol. Metab.* 7, 355–392.
- Antoni, F.A. (1986). Hypothalamic control of adrenocorticotropin secretion: Advances since the discovery of 41-residue corticotropin-releasing factor. *Endocr. Rev.* 7, 351–378.
- Assenmacher, I., Szafarczyk, A., Barbanel, G., Ixart, G., & Alonso, G. (1989). The catecholaminergic control of the hypothalamo-pituitary-adrenal axis. In: *The Control of the Hypothalamo-Pituitary Adrenocortical Axis* (Rose, F.C., Ed.), pp. 203–214. International Universities Press, Madison, CT.
- Bolton, C., & Flower, R.J. (1989). The effects of the anti-glucocorticoid RU 38486 on steroid-mediated suppression of experimental allergic encephalomyelitis (EAE) in the Lewis rat. *Life Sci.* 45, 97–104.
- Bradbury, M.J., Cascio, C.S., Scribner, K.A., & Dallman, M.F. (1991). Stress-induced adrenocorticotropin secretion: Diurnal responses and decreases during stress in the evening are not dependent on corticosterone. *Endocrinology* 128, 680–688.
- Brady, L.S., Gold, P.W., Herkenham, M., Lynn, A.B., & Whitfield, H.J., Jr. (1992). The antidepressants fluoxetine, idazoxan and phenelzine alter corticotropin-releasing hormone and tyrosine hydroxylase mRNA levels in rat brain: therapeutic implications. *Brain Res.* 572, 117–125.
- Brady, L.S., Whitfield, H.J., Jr., Fox, R.J., Gold, P.W., & Herkenham, M. (1991). Long-term antidepressant administration alters corticotropin-releasing hormone, tyrosine hydroxylase, and mineralocorticoid receptor gene expression in rat brain. *J. Clin. Invest.* 87, 831–837.
- Calogero, A.E., Kamilaris, T.C., Johnson, E.O., Tartaglia, M.E., & Chrousos, G. (1990). Recovery of the rat hypothalamo-pituitary-adrenal axis after discontinuation of prolonged treatment with the synthetic glucocorticoid agonist dexamethasone. *Endocrinology* 127, 1574–1579.
- Campbell, W.B. (1990). Lipid-derived autacoids: eicosanoids and platelet-activating factor. In: *Goodman and Gilman's The Pharmacological Basis of Therapeutics* (Gilman, A.G., Rall, T.W., Nies, A.S., & Taylor, P., Eds.), pp. 600–617. Pergamon, New York.
- Carlsson, A., Falck, B., & Hillarp, N.-A. (1962). Cellular localization of brain monoamines. *Acta Physiologica Scandinavica* 56, Suppl. 196, 1–27.
- Cunningham, E.T., Jr, & Sawchenko, P.E. (1988). Anatomical specificity of noradrenergic inputs to the paraventricular and supraoptic nuclei of the rat hypothalamus. *J. Comp. Neurol.* 274, 60–76.
- de Goeij, D.C.E., Kvetnansky, R., Whitnall, M.H., Jezova, D., Berkenbosch, F., & Tilders, F.J.H. (1991). Repeated stress enhances AVP stores and colocalization with CRF in the median eminence of rats. *Neuroendocrinology* 53, 150–159.
- Dunn, J., & Orr, S. (1984). Differential plasma corticosterone responses to hippocampal stimulation. *Exp. Brain Res.* 54, 1–6.
- Endrőczy, E., & Lissak, K. (1963). Effect of hypothalamic and brain stem structure stimulation on pituitary adrenocortical function. *Acta Physiologica Hungarica* 24, 67–77.
- Endrőczy, E., Lissak, K., & Bohus, B. (1959). The inhibitory influence of archicortical structures on pituitary adrenal function. *Acta Physiologica Academica Hungarica* 16, 17–24.

- Feldman, S., & Saphier, D. (1989). Extrahypothalamic neural afferents and the role of neurotransmitters in the regulation of adrenocortical secretion. In: *The Control of the Hypothalamo-Pituitary-Adrenocortical Axis* (Rose, F.C., Ed.), pp. 297–316. International Universities Press, Madison, CT.
- Gold, P.W., Goodwin, F.K., & Chrousos, G.P. (1988). Clinical and biochemical manifestations of depression. Relation to the neurobiology of stress. *N. Engl. J. Med.* 319, 348–353, 413–420.
- Grossman, A.B., Costa, A., Navarra, P., & Tsgarakis, S. (1993). The regulation of hypothalamic corticotropin-releasing factor release: *in vitro* studies. In: *Corticotropin-Releasing Factor* (Ciba Foundation Symposium No. 172) (Chadwick, D.J., Marsh, J., & Ackrill, K., Eds.), pp. 129–150. Wiley, Chichester.
- Hashimoto, K., Suemaru, S., Takao, T., Sugawara, M., Makino, S., & Fensuka, O. (1988). Corticotropin-releasing hormone and pituitary-adrenocortical responses in chronically stressed rats. *Regul. Pept.* 23, 117–126.
- Herman, J.P., Schafer, M.K.-H., Thompson, R.C., & Watson, S.J. (1992). Rapid regulation of corticotropin-releasing hormone gene transcription *in vivo*. *Mol. Endocrinol.* 6, 1061–1069.
- Herman, J.P., Schafer, M.K.-H., Young, E.A., Thompson, R., Douglass, J., Akil, H., & Watson, S.J. (1989). Evidence for hippocampal regulation of neuroendocrine neurons of the hypothalamo-pituitary-adrenocortical axis. *J. Neurosci.* 9, 3072–3082.
- Jingami, H., Matsukura, S., Numa, S., & Imura, H. (1985). Effects of adrenalectomy and dexamethasone administration on the level of preprocorticotropin-releasing factor messenger ribonucleic acid (mRNA) in the hypothalamus and adrenocorticotropin/ β -lipotropin precursor mRNA in the pituitary in rats. *Endocrinology* 117, 1314–1320.
- Kiss, A., & Aguilera, G. (1992). Participation of α_1 -adrenergic receptors in the secretion of hypothalamic corticotropin-releasing hormone during stress. *Neuroendocrinology* 56, 153–160.
- Kjær, A., Knigge, U., Bach, F.W., & Warberg, J. (1992). Histamine- and stress-induced secretion of ACTH and β -endorphin: Involvement of corticotropin-releasing hormone and vasopressin. *Neuroendocrinology* 56, 419–428.
- Kjær, A., Knigge, U., Madsen, E.L., Sjøe-Jensen, P., Bach, F.W., & Warberg, J. (1993a). Insulin/hypoglycemia-induced adrenocorticotropin and β -Endorphin release: Involvement of hypothalamic histaminergic neurons. *Endocrinology* 132, 2213–2220.
- Kjær, A., Knigge, U., Vilhardt, H., Bach, F.W., & Warberg, J. (1993b). Involvement of vasopressin V_1 - and V_2 -receptors in histamine- and stress-induced secretion of ACTH and β -endorphin. *Neuroendocrinology* 57, 503–509.
- Kjær, A., Knigge, U., Vilhardt, H., & Warberg, J. (1993c). Involvement of vasopressin in histamine- and stress-induced prolactin release: permissive, mediating or potentiating role? *Neuroendocrinology* 57, 314–321.
- Knigge, K.M., & Hays, M. (1963). Evidence of inhibitive role of hippocampus in regulation of ACTH release. *Proc. Soc. Exp. Biol. Med.* 114, 67–69.
- Knigge, U., Matzen, S., Bach, F.W., Bang, P., & Warberg, J. (1989). Involvement of histaminergic neurons in the stress-induced release of pro-opiomelanocortin-derived peptides in rats. *Acta Endocrinol. (Copenh.)* 120, 533–539.
- Kovács, K.J., & Makara, G. (1988). Corticosterone and dexamethasone act at different brain sites to inhibit adrenalectomy-induced adrenocorticotropin hypersecretion. *Brain Res.* 474, 205–210.
- Krieger, D.T. (Ed.) (1979). *Endocrine Rhythms*. Raven Press, New York.
- MacPhee, I.A., Antoni, F.A., & Mason, D.W. (1989). Spontaneous recovery of rats from experimental allergic encephalomyelitis is dependent on regulation of the immune system by endogenous adrenal corticosteroids. *J. Exp. Med.* 169, 431–445.
- Majzoub, J.A., Emanuel, R., Adler, G., Martinez, C., Robinson, B., & Wittert, G. (1993). Second messenger regulation of mRNA for corticotropin-releasing factor. In: *Corticotropin Releasing*

- Factor (Ciba Foundation Symposium No. 172) (Chadwick, D.J., Marsh, J., & Ackrill, K., Eds.), pp. 30–58. Wiley, Chichester.
- Mefford, I.N., Masters, C.F., Heyes, M.P., & Eskay, R.L. (1991). Cytokine-induced activation of the neuroendocrine stress axis persists in endotoxin-tolerant mice. *Brain Res.* 557, 327–330.
- Mengozi, M., & Ghezzi, P. (1991). Defective tolerance to the toxic and metabolic effects of interleukin 1. *Endocrinology* 128, 1668–1672.
- Munck, A., Guyre, P.M., & Holbrook, N.J. (1984). Physiological functions of glucocorticoids in stress and their relation to pharmacological actions. *Endocr. Rev.* 5, 25–44.
- Perlstein, R.S., Whitnall, M.H., Abrams, J.S., Mougey, E.H., & Neta, R. (1993). Synergistic roles of interleukin-6, interleukin-1, and tumor necrosis factor in the adrenocorticotropin response to bacterial lipopolysaccharide *in vivo*. *Endocrinology* 132, 946–952.
- Plotsky, P.M. (1986). Opioid inhibition of immunoreactive corticotropin-releasing factor secretion into the hypophysial-portal circulation of rats. *Regul. Pept.* 16, 235–242.
- Raadsheer, F.C., Sluiter, A.A., Ravid, R., Tilders, F.J.H., & Swaab, D.F. (1993). Localization of corticotropin-releasing hormone (CRH) neurons in the paraventricular nucleus of the human hypothalamus; age-related colocalization with vasopressin. *Brain Res.* 615, 50–62.
- Reul, J.M.H.M., & DeKloet, E.R. (1985). Two receptor systems for corticosterone in rat brain: Microdistribution and differential occupation. *Endocrinology* 117, 2505–2511.
- Robinson, B.G., Mealy, K., Wilmore, D.W., & Majzoub, J.A. (1992). The effect of insulin-induced hypoglycemia on gene expression in the hypothalamic-pituitary-adrenal axis of the rat. *Endocrinology* 130, 920–925.
- Sapolsky, R.M., Krey, L.C., & McEwen, B.S. (1984). Glucocorticoid-sensitive hippocampal neurons are involved in terminating the adrenocortical stress response. *Proc. Natl. Acad. Sci. USA* 81, 6174–6177.
- Sapolsky, R.M., Zola-Morgan, S., & Squire, L.R. (1991). Inhibition of glucocorticoid secretion by the hippocampal formation in the primate. *J. Neurosci.* 11, 3695–3704.
- Sawchenko, P.E., Swanson, L.W., Grzanna, R., Howe, P.R.C., Bloom, S.R., & Polak, J.M. (1985). Colocalization of neuropeptide Y immunoreactivity in brainstem catecholaminergic neurons that project to the paraventricular nucleus of the hypothalamus. *J. Comp. Neurol.* 241, 138–153.
- Scaccianoce, S., Cigliana, G., Nicolai, R., Navarra, D., Muscolo, L.A.A., & Angelucci, L. (1992). Pituitary-adrenocortical response following repeated adrenocorticotropin secretagogue administration in the rat. *Stress Medicine* 8, 207–211.
- Schauenstein, K., Fassler, R., Dietrich, H., Schwarz, S., Kromer, G., & Wick, G. (1987). Disturbed immune-endocrine communication in autoimmune disease. Lack of corticosterone response to immune signals in obese strain chickens with spontaneous autoimmune thyroiditis. *J. Immunol.* 139, 1830–1833.
- Schilling, K., Schmale, H., Oeding, P., & Pilgrim, C. (1991). Regulation of vasopressin expression in cultured diencephalic neurons by glucocorticoids. *Neuroendocrinology* 53, 528–535.
- Selye, H. (1976). *Stress in Health and Disease*. Butterworth, Boston.
- Silverman, A.-J., Hou-Yu, A., & Kelley, D.D. (1989). Modification of hypothalamic neurons by behavioral stress. In: *Neuropeptides and Stress* (Tache, Y., Morley, J.E., & Brown, M.R., Eds.), pp. 23–38. Springer-Verlag, New York.
- Sternberg, E.M. (1992). The stress response and the regulation of inflammatory disease. *Ann. Int. Med.* 117, 854–866.
- Sternberg, E.M., Young, W.S., III, Bernardini, R., Calogero, A.E., Chrousos, G.P., Gold, P.W., & Wilder, R.L. (1989). A central nervous system defect in biosynthesis of corticotropin-releasing hormone is associated with susceptibility to streptococcal cell wall-induced arthritis in Lewis rats. *Proc. Natl. Acad. Sci. USA* 86, 4771–4775.

- Swanson, L.W., Sawchenko, P.E., Berod, A., Hartman, B.K., Helle, K.B., & Van Orden, D.E. (1981). An immunohistochemical study of the organization of catecholaminergic cells and terminal fields in the paraventricular and supraoptic nuclei of the hypothalamus. *J. Comp. Neurol.* 196, 271–285.
- Sweep, C.G.J., van der Meer, M.J.M., Hermus, A.R.M.M., Smals, A.G.H., van der Meer, J.W.M., Pesman, G.J., Willemsen, S.J., Benraad, T.J., & Kloppenborg, P.W.C. (1992). Chronic stimulation of the pituitary-adrenal axis in rats by interleukin-1 β infusion: *In vivo* and *in vitro* studies. *Endocrinology* 130, 1153–1164.
- Takasu, H., Komiya, I., Nagasawa, Y., Asawa, T., & Yamada, T. (1990). Exacerbation of autoimmune thyroid dysfunction after unilateral adrenalectomy in patients with Cushing's syndrome due to an adrenocortical adenoma. *N. Engl. J. Med.* 322, 1708–1712.
- Van de Kar, L.D., Piechowski, R.A., Rittenhouse, P.A., & Gray, T.S. (1991). Amygdaloid lesions-differential effect on conditioned stress and immobilization-induced increases in corticosterone and renin secretion. *Neuroendocrinology* 54, 89–95.
- Verbeeck, M.A.E., Sutanto, W., & Burbach, J.P.H. (1991). Regulation of vasopressin messenger RNA levels in the small cell lung carcinoma cell line GLC-8: interactions between glucocorticoids and second messengers. *Mol. Endocrinol.* 5, 795–801.
- Vinson, G.P., Whitehouse, B., & Hinson, J. (1992). *The Adrenal Cortex*. Prentice Hall, Englewood Cliffs, NJ.
- von Werder, K., & Müller, O.A. (1993). The role of corticotropin-releasing factor in the investigation of endocrine diseases. In: *Corticotropin Releasing Factor (Ciba Foundation Symposium No. 172)* (Chadwick, D.J., Marsh, J., & Ackrill, K. Eds.), pp. 317–336. Wiley, Chichester.
- Watts, A.G. (1992). Disturbance of fluid homeostasis leads to temporally and anatomically distinct responses in neuropeptide and tyrosine hydroxylase mRNA levels in the paraventricular and supraoptic nuclei of the rat. *Neuroscience* 46, 859–879.
- Watts, A.G., & Swanson, L.W. (1989). Diurnal variations in the content of prepro-corticotropin-releasing hormone messenger ribonucleic acids in the hypothalamic paraventricular nucleus of rats of both sexes as measured by *in situ* hybridization. *Endocrinology* 125, 1734–1738.
- Whitnall, M.H. (1988). Distributions of pro-vasopressin expressing and provasopressin deficient CRH neurons in the paraventricular hypothalamic nucleus of colchicine-treated normal and adrenalectomized rats. *J. Comp. Neurol.* 275, 13–28.
- Whitnall, M.H. (1989). Stress selectively activates the vasopressin-containing subset of corticotropin-releasing hormone neurosecretory cells. *Neuroendocrinology* 50, 702–707.
- Whitnall, M.H. (1993). Regulation of the hypothalamic corticotropin-releasing hormone neurosecretory system. *Prog. Neurobiol.* 40, 573–629.
- Whitnall, M.H., Perlstein, R.S., Mougey, E.H., & Neta, R. (1992a). The hypothalamo-pituitary-adrenal axis in rodents: corticotropin-releasing hormone/vasopressin coexistence and cytokine effects. In: *Stress: Neuroendocrine and Molecular Approaches* (Kvetnansky, R., McCarty, R., & Axelrod, J., Eds.), pp. 449–456. Gordon and Breach Science Publishers, New York.
- Whitnall, M.H., Perlstein, R.S., Mougey, E.H., & Neta, R. (1992b). Effects of interleukin-1 on the stress-responsive and -nonresponsive subtypes of corticotropin-releasing hormone neurosecretory axons. *Endocrinology* 131, 37–44.
- Whitnall, M.H., Kiss, A., & Aguilera, G. (1993). Contrasting effects of central alpha-1 adrenoreceptor activation on stress-responsive and nonresponsive subpopulations of corticotropin-releasing hormone neurosecretory cells in the rat. *Neuroendocrinology* 58, 42–48.
- Young, W.S., III, Mezey, E., & Siegel, R.E. (1986a). Quantitative *in situ* hybridization histochemistry reveals increased levels of corticotropin-releasing factor mRNA after adrenalectomy in rats. *Neuroscience Lett.* 70, 198–203.
- Young, W.S., III, Mezey, E., & Siegel, R.E. (1986b). Vasopressin and oxytocin mRNAs in adrenalectomized and Brattleboro rats: Analysis by quantitative *in situ* hybridization histochemistry. *Mol. Brain Res.* 1, 231–241.

RECOMMENDED READINGS

- Antoni, F.A. (1986). Hypothalamic control of adrenocorticotropin secretion: Advances since the discovery of 41-residue corticotropin-releasing factor. *Endocr. Rev.* 7, 351–378.
- Crawley, J.N., & McLean, S. (Eds.) (1996). *Neuropeptides: Basic and Clinical Advances*, Vol. 780. Ann. NY Acad. Sci.
- Whitnall, M.H. (1993). Regulation of the hypothalamic corticotropin-releasing hormone neurosecretory system. *Prog. Neurobiol.* 40, 573–629.

This Page Intentionally Left Blank

Chapter 4

**Functional Morphology of
Hypophysiotropic
Hormone-Synthesizing Neurons:**
IDENTIFICATION, CONNECTIVITY, AND
PLASTICITY

ISTVÁN MERCHENTHALER

Introduction	121
The Hypophysiotropic Hormones as Regulators of Anterior Pituitary Hormone Secretion	123
Hypophysiotropic Areas in the Brain	125
Location of HPT Perikarya	125
Hypophysiotropic Pathways	133
Connectivity of Hypophysiotropic Neurons: Afferents and Colocalization	135
Afferents of Hypophysiotropic Neurons	135
Colocalization of Different Factors in Hypophysiotropic Neurons	136
Conclusions	142

Principles of Medical Biology, Volume 10A
Molecular and Cellular Endocrinology, pages 119–144.
Copyright © 1997 by JAI Press Inc.
All rights of reproduction in any form reserved.
ISBN: 1-55938-815-3

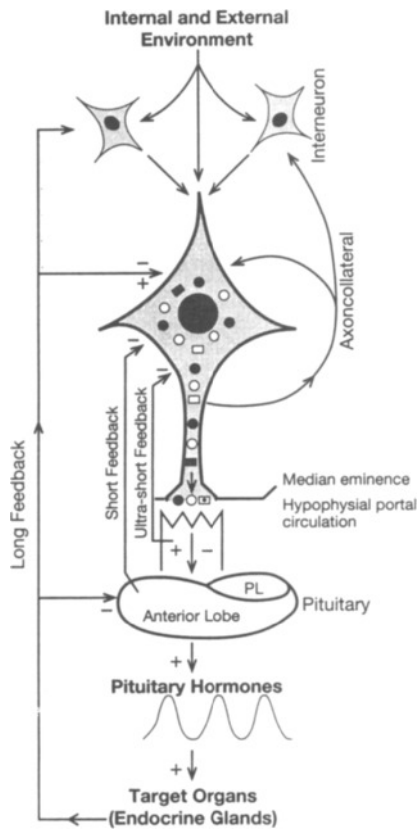

Figure 1. Schematic representation of integrated neuroendocrine control of the anterior pituitary. Exogenous and endogenous stimuli are first encoded as neurochemical signals and are then processed in the CNS activating a widespread neuronal network involved in the regulation of the anterior pituitary. Subsequently, these signals are transported via multiple pathways to the HPT neurons where they are transformed into HPT messages. The HPT hormones are secreted in a stimulus-specific fashion from nerve terminals of the external zone of the ME into the hypophysial portal circulation through which they reach cells of the anterior pituitary. Via regulation of anterior pituitary hormone secretion, the HPT factors, subsequently, influence the activity of peripheral endocrine glands. Hormones or peptides of the endocrine glands, in turn, inhibit HPT factor production and anterior pituitary hormone release by acting through specific receptors present in both the brain and the pituitary (long feedback regulation). At certain concentrations and under certain physiological circumstances some of these hormones may stimulate the expression and/or production and release of certain HPT factors (e.g. estradiol stimulates LHRH and galanin release during proestrus). (*continued*)

INTRODUCTION

The functions of the anterior pituitary are controlled primarily by hypophysiotropic (HPT) neurons in the hypothalamus. Their messengers, HPT factors, or hormones,¹ the majority of which are peptides, are transported via axons to nerve terminals in the external zone of the median eminence (ME) where they are released into capillaries of the hypophysial portal circulation.^{2,3} These capillaries then empty into larger veins running on the surface of the pituitary stalk toward the distal lobe of the pituitary gland. Here, the veins branch into capillaries which release the HPT hormones into the intercellular space through which they reach their target cells. Although most HPT hormones are stimulatory, some of them have inhibitory functions. The HPT neurons, therefore, regulate the functions of the anterior pituitary with the HPT hormones and, subsequently, the secretion of peripheral endocrine glands (ovaries, testes, adrenals, and thyroids), the mammary glands, the pancreas, and other tissues. The HPT neurons act as “neuroendocrine transducers” by transforming neural and humoral inputs from different brain areas and the periphery into neurochemical commands (HPT hormones) which activate or inhibit the secretion of different anterior pituitary hormones. The integrated neuroendocrine control of the anterior pituitary is schematically represented in Figure 1.

The ME, which consists of an internal and external zone, plays an important role in neuroendocrine regulatory mechanisms by providing a link between the brain and the pituitary. The internal zone, which provides the neuronal link, contains primarily fibers (Figure 2B) projecting from neurons of the magnocellular hypothalamic nuclei (paraventricular, supraoptic, and accessory) toward the posterior and, to a lesser extent, intermediate lobes of the pituitary. These neurons secrete, among other substances, arginine-vasopressin, oxytocin, dynorphins, galanin, vasoactive intestinal peptide (VIP), enkephalins (ENK), cholecystokinin (CCK), and nitric oxide (NO). In contrast, the major components of the external zone, which provide the vascular link between the hypothalamus and the anterior pituitary, are the

Figure 1. (Continued) Hormones of the anterior pituitary not only regulate the function of the endocrine glands and other peripheral tissues (e.g. growth hormone and prolactin do not have specific target organs; rather, they affect multiple cell types), but they may be transported back to the hypothalamus through stalk veins to inhibit the activity of HPT factor-producing neurons (short feedback regulation). The HPT factors can also regulate the activity of HPT neurons via ultra-short feedback mechanism. Via a well-established vascular connection between the hypophysial portal circulation and the medial basal hypothalamus, the HPT hormones from the ME can be transported back to the medial basal hypothalamus to inhibit their own release (chemical ultra-short feedback regulation). In addition, the HPT hormones can regulate their own synthesis or release through axon collaterals contacting their own perikarya or those of other HPT neurons (neuronal ultra-short feedback regulation).

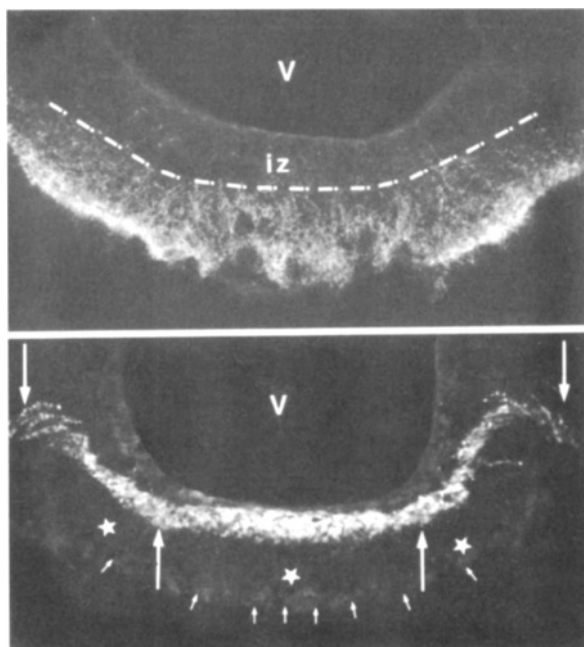

Figure 2. The characteristic location of HPT (e.g. TRH) and non-HPT (e.g. vasopressin) factors in the ME. While the TRH-containing nerve terminals occupy the external zone of the ME (immunoreactivity below the dotted line in **A**), vasopressin is present in axons running in the internal zone (iz) of the ME (white arrows in **B**) toward the posterior pituitary. The external zone (*white stars*) is free of vasopressin immunoreactivity. The HPT factors are released into the hypophysial portal circulation within the ME; the factors in axons in the internal zone are released into the general circulation within the posterior lobe of the pituitary.

specialized vasculature of the hypophysial portal system and nerve terminals of parvocellular HPT neurons (Figures 2A, 3).

The endothelium of the portal capillary system is fenestrated; therefore, no blood–brain barrier exists in the ME. Consequently, the HPT hormones can easily cross the walls of these capillaries bidirectionally allowing their release from contacting nerve terminals into the capillary loops, or perhaps their uptake from the blood stream by other nerve terminals. In addition to nerve fibers and terminals, both the internal and the external zones of the ME contain glial cells and scattered, mostly neuropeptide Y (NPY)- and β -endorphin-containing neurons. For anatomical details see Ambach and Palkovits (1979) and Page (1991).

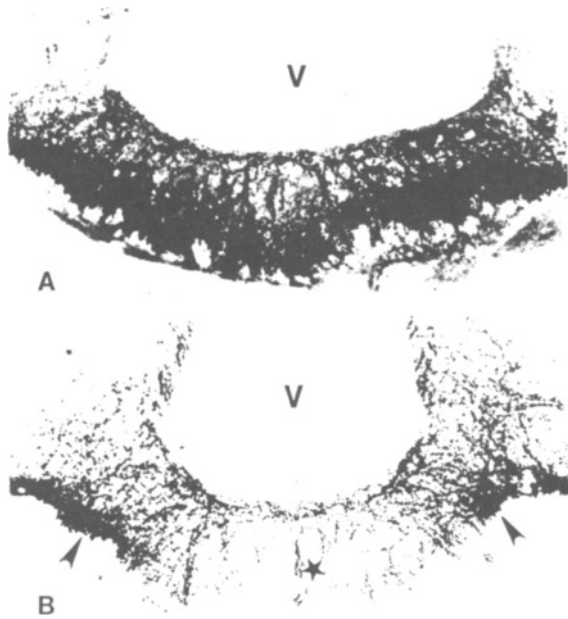

Figure 3. CRH- and LHRH-containing nerve terminals in the ME. Note that while LHRH-containing nerve terminals occupy the lateral portion of the external zone of the ME (arrowheads in **B**) and cannot be seen in the middle portion (*star*), CRH-containing nerve terminals (**A**) are evenly distributed in the entire width of the external zone of the ME. The nerve terminals of HPT neurons contact capillaries of the hypophysial portal circulation. A portion of nerve terminals, however, contact other nerve processes and, via axo-axonic synapses, the HPT factors can regulate presynaptically the release of each other. The presence of tyrosine hydroxylase representing dopamine-containing nerve terminals on LHRH-immunopositive processes has been reported (Kuljis et al., 1989). V: 3rd ventricle.

THE HYPOPHYSIOTROPIC HORMONES AS REGULATORS OF ANTERIOR PITUITARY HORMONE SECRETION

In establishing any chemical messenger as an HPT factor, certain criteria must be satisfied: (1) the messenger should be present in nerve terminals of the external zone of the ME; (2) the portal blood must contain the messenger in higher concentrations than peripheral plasma; (3) specific receptors for the messenger should be present on anterior pituitary cells; and (4) the messenger must affect anterior pituitary hormone secretion at concentrations found in the portal blood.

Nearly 40 putative chemical messengers, mainly peptides, have been localized and their concentrations measured in the ME⁴. Based on their action on pituitary

hormone secretion, these messengers can be divided into two major groups: *classical* and *nonclassical* HPT hormones (Table 1). Except for the classical HPT hormones, most of the other factors found in the ME do not satisfy all of these criteria. However, their mere presence in the external zone of the ME implicates their action upon pituitary hormone secretion. It is important to emphasize, however, that the mere presence of a factor (e.g. neurophysin or gonadotropin-associated peptide) in the ME, without satisfying all or most of the other criteria,

Table 1. Chemical Messengers (Hypophysiotropic Factors) in the Median Eminence and the Location of Neurons Producing these Factors

<i>Hypophysiotropic (HPT) Factors</i>		<i>Location of Cell Bodies</i>
Classical HPT factors		
CRH:	Corticotropin-releasing hormone	Paraventricular nucleus
GHRH:	Growth hormone-releasing hormone	Arcuate nucleus
LHRH:	Luteinizing hormone-releasing hormone	Diagonal band of Broca, Medial septum, Preoptic area
SRIF:	Somatostatin	Anterior periventricular area
TRH:	Thyrotropin-releasing hormone	Paraventricular nucleus
PIF:	Dopamine	Arcuate nucleus
Nonclassical HPT factors		
	Vasopressin	Paraventricular nucleus
	Oxytocin	Paraventricular nucleus
POMC:	Proopiomelanocortin-derived peptides: ACTH, α -MSH, β -endorphin	Medial basal hypothalamus, primarily the arcuate nucleus
GAL:	Galanin	Arcuate and paraventricular nuclei
NT:	Neurotensin	Arcuate and paraventricular nuclei
NPY:	Neuropeptide Y	Arcuate nucleus
VIP:	Vasoactive intestinal polypeptide	Paraventricular nucleus
PHI-27:	Peptide histidine isoleucine	Paraventricular nucleus
ANG II:	Angiotensin II	Paraventricular nucleus
BNP:	Brain natriuretic peptide	Paraventricular nucleus
CCK:	Cholecystokinin	Paraventricular nucleus
ENK:	Enkephalins	Paraventricular nucleus
DYN:	Dynorphins	Paraventricular and supraoptic nuclei
DSIP:	Delta sleep-inducing peptide	Diagonal band of Broca, medial septum, medial preoptic area
	Glucagon	Paraventricular, supraoptic and arcuate nuclei
	Substance P	Arcuate nucleus
NKB:	Neurokinin B	Arcuate nucleus
	Endothelins	?

Note: The information is based primarily on data summarized in two review articles by Palkovits (1984, 1986).

does not necessarily mean that this substance, although produced by HPT neurons, participates in the regulation of anterior pituitary hormone secretion.

HYPOPHYSIOTROPIC AREAS IN THE BRAIN

Location of HPT Perikarya

The “hypophysiotropic area” was originally defined as those regions of the hypothalamus, the arcuate nucleus and retrochiasmatic area, which maintain or nourish the secretory activity of ectopic anterior pituitary grafts (Szentágothai et al., 1962; Halász et al., 1969). It was believed that all the HPT factor-producing neurons are located in this region. Interestingly, following the elucidation of the chemical structures of the HPT factors, immunocytochemical studies using specific antibodies against these neurohormones did not confirm the location of the HPT hormone-producing neurons suggested by the previous studies but demonstrated that most of them were located outside the classical HPT area. More surprisingly, their locations were not restricted to the hypothalamus, but many were widely distributed in the central nervous system even in areas known not to project to the ME. These studies provided the first evidence for the notion that, depending on the site of release, the HPT factors can act as true HPT hormones released into the hypophysial portal circulation from the ME or as neuromodulators/neurotransmitters released into synaptic clefts or the intercellular spaces at several sites of the central nervous system (Figure 4). The neurotransmitter/neuromodulator function of the HPT hormones exists even within the ME where they, following release from nerve terminals, can stimulate or inhibit the release of other HPT hormones via axo-axonic synapses (Kuljis and Davis, 1989).

At present, *in vivo* retrograde labeling with tracers injected into the surgically isolated ME (e.g. wheat germ agglutinin and horseradish peroxidase) or injected peripherally (e.g. fluoro-gold) allows the identification of those neurons projecting to the ME, i.e. the true HPT neurons. The peripherally injected tracers do not cross the blood-brain barrier but are picked up by nerve terminals where this barrier is absent, e.g. in the ME.

The observations of retrograde labeling studies indicated that, in rodents, the major regions that contain the HPT neurons include the medial septum, diagonal band of Broca, medial preoptic area, anterior periventricular nucleus, parvicellular subdivisions of the paraventricular nucleus, and the arcuate nucleus (Lechan et al., 1981). In monkeys and humans, the contribution of the medial septum, the diagonal band of Broca, and the preoptic area to the HPT neuronal system is negligible. Examples of retrograde labeling with locally injected wheat germ agglutinin or peripherally injected fluoro-gold are shown in Figures 5 and 6, respectively.

The retrograde labeling technique can be combined with immunocytochemistry for the endogenous HPT factor and, if necessary, for the retrograde tracer, and the two substances can be visualized simultaneously (Merchenthaler, 1991). Figure 7

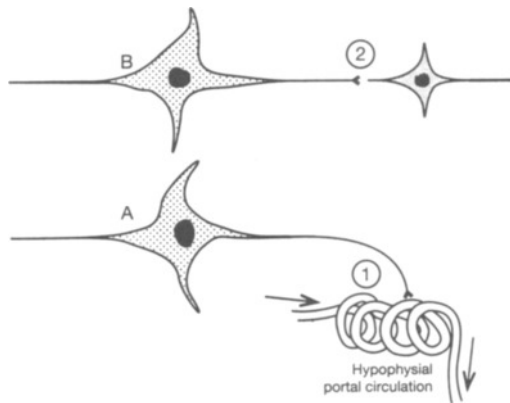

Figure 4. Two types of HPT hormone-containing neurons. Neuron **A** forms nerve terminals on capillaries of the hypophysial portal circulatory system in the ME (1); the chemical messenger produced by this neuron regulates neuroendocrine functions. Neuron **B**, in producing the same chemical messenger, does not contact the ME but innervates other neurons (HPT and/or non-HPT neurons) in the brain. The same chemical messenger functions as an HPT hormone in the first neuron (1) but as a neurotransmitter or neuromodulator in the second neuron (2). Therefore, depending on the site of release, the HPT hormones exhibit different functions.

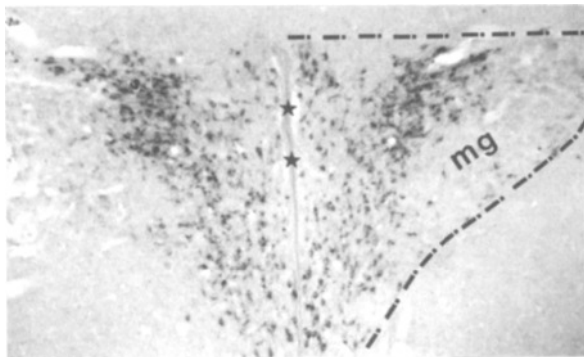

Figure 5. Retrograde labeling with wheat germ agglutinin (WGA) injected locally into the external zone of the ME and immunostained with the PAP technique utilizing DAB as chromogen. WGA-accumulating perikarya are shown in the paraventricular nucleus where they occupy the parvicellular subdivisions (surrounded by interrupted lines). The magnocellular subdivisions (mg) are void of WGA-containing perikarya. Stars represent the ependymal lining of the 3rd ventricle. (For details see Merchenthaler, 1990).

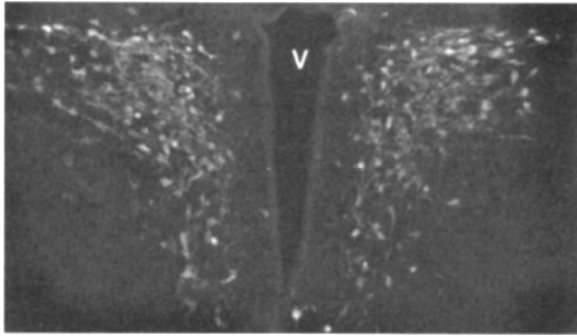

Figure 6. Retrograde labeling with peripherally injected fluoro-gold. The section is taken from the paraventricular nucleus of the hypothalamus and shows a distribution similar to that of Figure 5. V: 3rd ventricle.

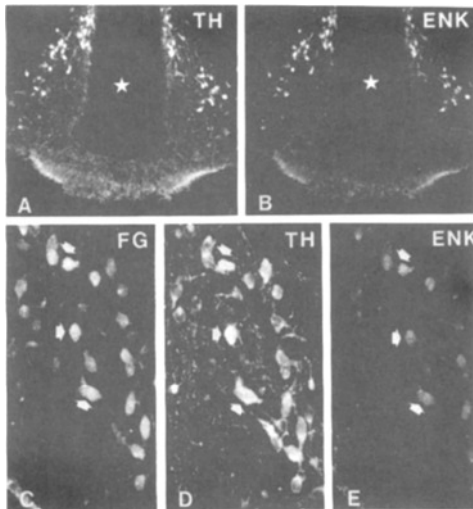

Figure 7. Colocalization of HPT factors in combination with retrograde labeling. Tyrosine hydroxylase (TH), representing dopamine (A), is colocalized with enkephalin (ENK in B) in the arcuate nucleus of a lactating rat. The images in A and B are identical, indicating a perfect colocalization of the two HPT factors. Stars label the 3rd ventricle. Higher magnification of fluoro-gold- (FG in C), TH (D) and enkephalin (E) containing perikarya in the arcuate nucleus of a lactating rat. Note that the three images, although with somewhat different intensity, are identical. White arrows are for orientation. Texas red was used for the demonstration of TH and FITC for enkephalin.

demonstrates the colocalization of dopamine, represented by tyrosine hydroxylase, and enkephalin with fluoro-gold in the arcuate nucleus of a lactating rat.

Studies utilizing a combination of retrograde labeling and immunocytochemistry for a given HPT hormone established the location of HPT hormones (see Table 1). Figures 8–10 show immunostained perikarya in the major HPT areas. Among the classical HPT hormones, LHRH is localized in perikarya in the diagonal band of Broca/medial preoptic area (Figure 8A), somatostatin in the anterior periventricular nucleus (Figure 8B), CRH and TRH (Figure 9A) in the paraventricular nucleus, and dopamine (shown in Figure 7A) and GHRH (Figure 9C) in the arcuate nucleus. In monkeys and human, the major location of HPT LHRH-containing perikarya is the infundibular nucleus (Silverman, 1993).

The colocalization of two nonclassical HPT hormones, enkephalin and β -endorphin, are shown in Figure 10. Although β -endorphin has been measured in high concentrations in hypophysial portal blood, there are few, if any, β -endorphin-containing nerve terminals in the external zone of the median eminence (Figure 10), although immunopositive perikarya are present in the arcuate

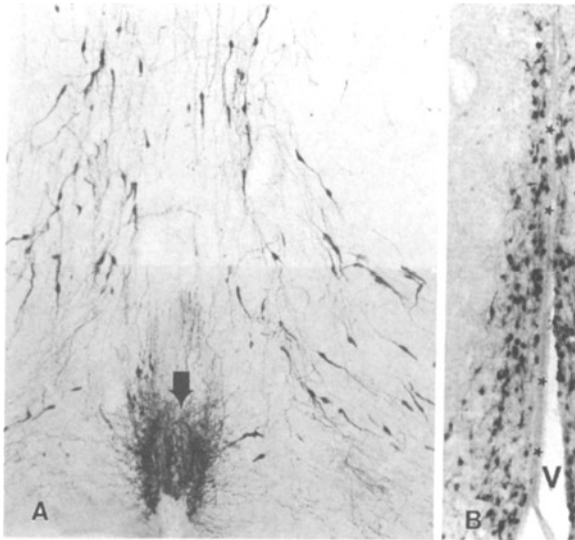

Figure 8. Light microscopic immunocytochemical demonstration of LHRH-immunoreactive perikarya in the diagonal band of Broca/medial preoptic area at the level of the organum vasculosum of the lamina terminalis (*arrow*) (A) and somatostatin-containing perikarya in the anterior periventricular nucleus (B). Note that the fusiform LHRH-containing perikarya are intermixed with unlabeled perikarya, while the somatostatin-containing perikarya are densely packed. The ependymal wall of the 3rd ventricle (V) is represented by small stars in B.

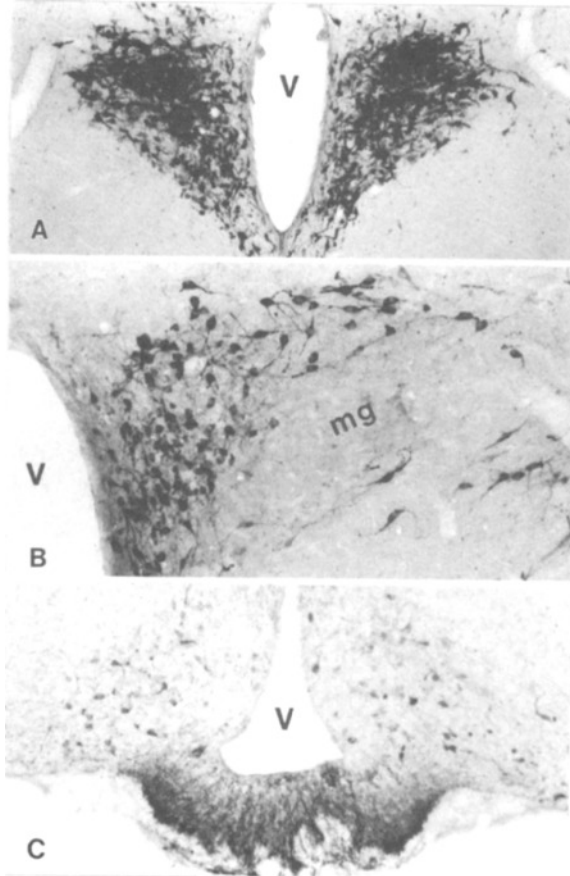

Figure 9. CRH-containing perikarya in the paraventricular nucleus (A), TRH-immunopositive perikarya in the paraventricular nucleus (B), and GHRH-containing cell bodies in the arcuate nucleus (C). Within the paraventricular nucleus, TRH-immunoreactive perikarya are present in the parvocellular subdivisions. The magnocellular subdivision (mg) is free of TRH-containing perikarya. In the arcuate nucleus, GHRH-immunoreactive cells occupy the ventrolateral subdivision of the nucleus (Everitt et al., 1986).

nucleus. The source of β -endorphin in hypophysial portal blood remains to be explored.

It is noteworthy that not each HPT hormone-containing perikaryon, even within a well-defined nucleus or region is retrogradely labeled, i.e. not all are connected to the hypophysial portal circulation. Only 70–75% of the LHRH-producing neurons from the diagonal band of the Broca/medial preoptic area (Merchenthaler et al., 1989) and approximately 75% of CRH- (Petrusz and Merchenthaler, 1992) and TRH-containing neurons (Lechan and Toni, 1992) from the paraventricular

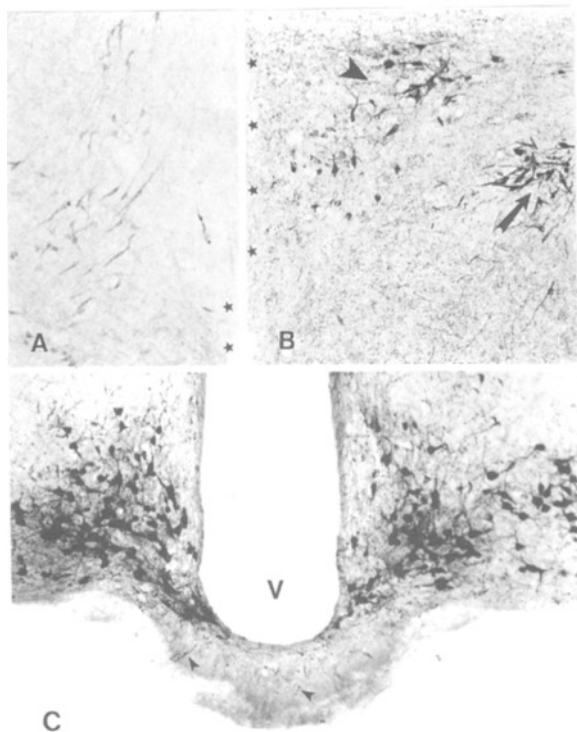

Figure 10. Galanin (A), enkephalin (B), and β -endorphin (C) containing perikarya in the diagonal band of Broca (A), the paraventricular (B), and arcuate (C) nuclei. Galanin is present in elongated “LHRH-like” perikarya in this region of the female rat. Stars indicate the organum vasculosum of the lamina terminalis. Enkephalin is present in the parvicellular subdivision of the paraventricular nucleus (*arrowhead*). Arrow shows larger perikarya lateral to the paraventricular nucleus. These perifornical neurons are not HPT; they project to the lateral septum. Although β -endorphin is present in perikarya of the arcuate nucleus, a known HPT nucleus, practically no immunoreactive fibers can be seen in the external zone of the ME. Small arrowheads label two of these fibers. V: 3rd ventricle.

nucleus of the hypothalamus project to the ME. However, almost all somatostatin-containing (Merchenthaler et al., 1989; Meister and Hökfelt, 1992) and dopamine-containing (Everitt et al., 1992) neurons from the anterior periventricular area and the arcuate nucleus, respectively, send their axons to the portal circulatory system. Therefore, HPT and non-HPT neurons are intermixed even within a well-defined nucleus of the hypothalamus. Thus, future studies must be conducted to identify the differences between these anatomically and functionally separate groups of HPT hormone-containing neurons. It is reasonable to speculate that when the

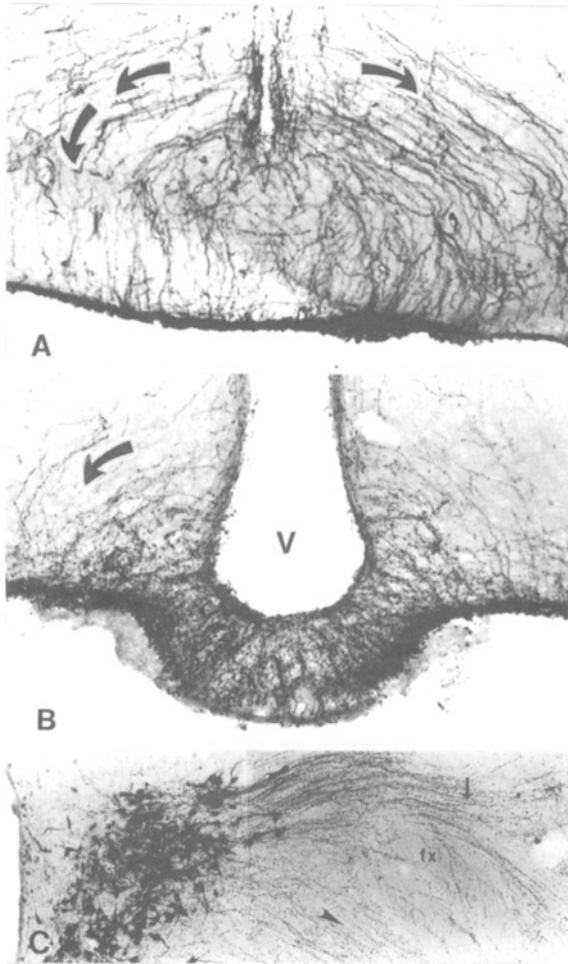

Figure 11. LHRH (A and B) and CRH (C) immunoreactive fibers at the level of the basal retrochiasmatic area (A), the midportion of the ME (B) and the paraventricular nucleus. Note the forceps-like projection (*curved arrow*) of LHRH-containing fibers from the periventricular pathway toward the ME. CRH-immunoreactive fibers from the paraventricular nucleus run baso-laterally above (*arrow*) and below (*arrowhead*) the fornix (fx). At the level of the basal retrochiasmatic area, these fibers turn medially and enter the ME. (For details see Palkovits, 1984; Merchenthaler et al., 1984; Petrusz and Merchenthaler, 1992).

Afferents of the Median Eminence

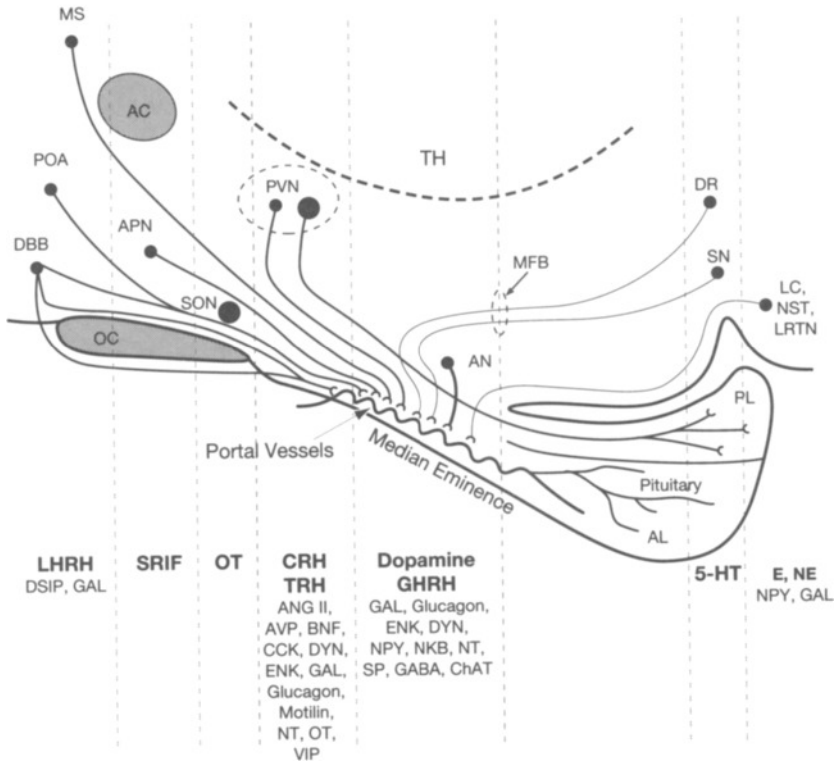

Figure 12. A schematic representation of the HPT area in rodents, the messengers produced by HPT neurons (the classical HPT hormones are highlighted), and the pathways via the axons of these neurons reach the ME. HPT neurons in the medial preoptic area, the diagonal band of Broca, and the medial septum produce LHRH, galanin, and DSIP. The anterior periventricular nucleus contains somatostatin-immunoreactive neurons. The paraventricular nucleus is the source of CRH, TRH, and many other nonclassical HPT factors. The arcuate nucleus contains GHRH, dopamine, and several other nonclassical HPT factors. The dorsal raphe (DR), the substantia nigra (SN), the locus ceruleus (LC), the nucleus of the solitary tract (NST), and the lateral reticular nucleus (LRTN) contain indoleamine-synthesizing (DR) and catecholamine-, NPY-, and galanin-producing (SN, LC, NST, LRTN) neurons that may project to the ME.

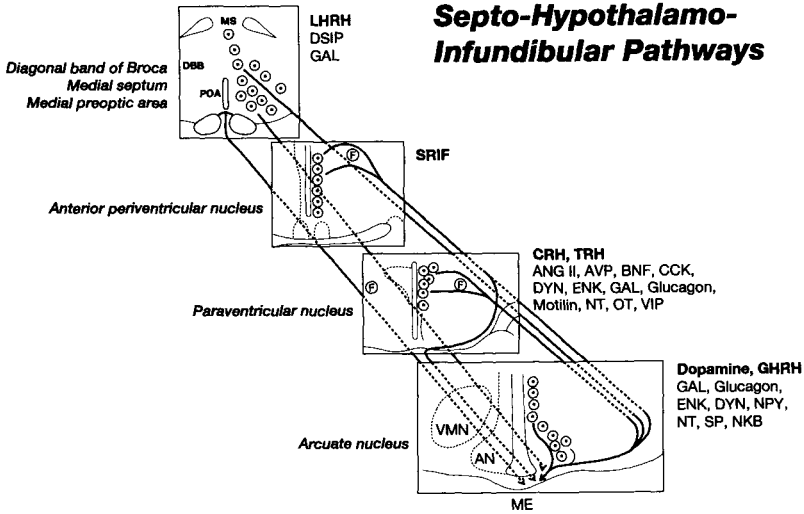

Figure 13. Schematic representation of the septo–hypothalamo–infundibular pathways in rat. The location of the HPT hormone-producing neurons is indicated on the left side of each cross section. The HPT factors produced by these perikarya are shown on the right. The classical HPT hormones are highlighted.

differences, possibly in receptors, connectivity, and colocalization are established, the functions of the true HPT neurons will be altered with specific agonists or antagonists without affecting those that contain the same HPT hormone but do not project to the ME.

Hypophysiotropic Pathways

Axons of both the classical and nonclassical HPT neurons follow well-defined pathways to the hypophysial portal circulation. The LHRH-immunoreactive neuronal system reaches the ME via one subchiasmatic and seven suprachiasmatic pathways [two lateral, two medial, an unpaired median, and two periventricular] (Figures 11A, B) (Merchenthaler et al., 1980, 1984; Hoffman et al., 1992; Silverman, 1993). Axons from somatostatin-containing neurons in the anterior periventricular area or from CRH- (Figure 11C), TRH-, enkephalin-, galanin-, and neurotensin-containing neurons in the paraventricular nucleus project to the ME via a fan-shaped pathway (Merchenthaler, 1991). Their fibers are concentrated in the lateral, basal retrochiasmatic area where they turn medially and enter the ME (Palkovits, 1984). The distribution of HPT neurons and their pathways to the ME are schematically represented in Figures 12–14 (also see Figures 18–19).

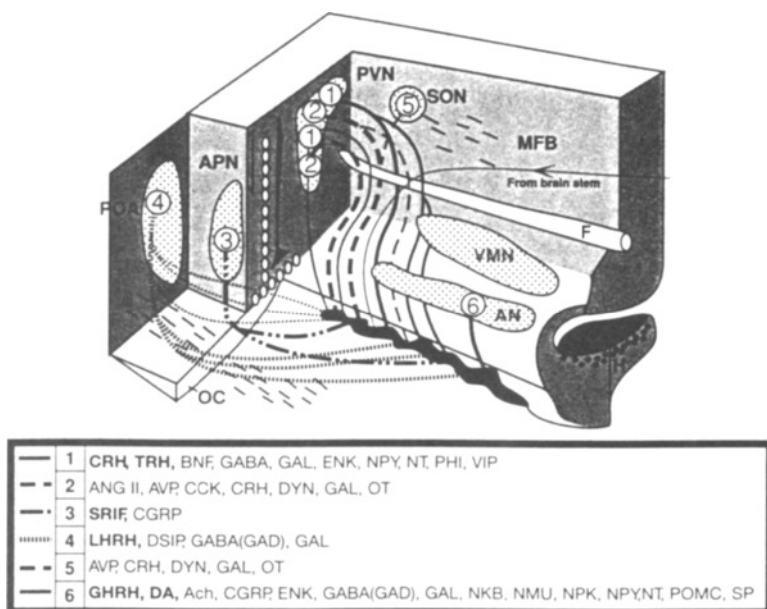

Figure 14. Three-dimensional representation of the topography of HPT neurons and their pathways to the ME. The main HPT areas or nuclei are indicated by Arabic numbers. (1) Paraventricular nucleus (PVN), pars parvocellularis. (2) Paraventricular nucleus (PVN), pars magnocellularis. (3) Anterior periventricular nucleus (APN). (4) Medial preoptic area (POA); the medial septum and the diagonal band of Broca also belong to this group. (5) Supraoptic nucleus (SON). (6) Arcuate nucleus (AN). The classical HPT hormones are produced by parvicellular neurons in regions 1–3 and 5. The HPT factors produced by neurons in nuclei 1 to 6 are indicated below. Axons from the periventricular and paraventricular nuclei form a curved fan of fibers above the optic chiasm and enter the medial basal hypothalamus through the lateral basal retrochiasmatic area (Palkovits, 1984), then run toward the ME. Fibers from the LHRH-containing neurons reach the ME via a subchiasmatic and several suprachiasmatic (two medial, lateral and periventricular) pathways (Merchenthaler et al., 1980, 1984). F: fornix; MFB: medial forebrain bundle. Abbreviations for the list of HPT factors in the order indicated are: CRH: corticotropin-releasing hormone; TRH: thyrotropin-releasing hormone; BNF: brain natriuretic factor; GABA: γ -aminobutyric acid; GAL: galanin; ENK: enkephalins; NPY: neuropeptide Y; NT: neurotensin; PHI: peptide histidine isoleucine; VIP: vasoactive intestinal polypeptide; ANG II: angiotensin II; AVP: arginine vasopressin; CCK: cholecystokinin; DYN: dynorphins; OT: oxytocin; SRIF: somatotropin release-inhibiting factor (somatostatin); CGRP: calcitonin gene-related peptide; LHRH: luteinizing hormone-releasing hormone; DSIP: delta sleep-inducing peptide; GAD: glutamate decarboxylase; GHRH: growth hormone-releasing hormone; DA: dopamine; Ach: acetylcholine; NKB: neurokinin B; NMU: neuromedin U; NPK: neuropeptide K; NT: neurotensin; POMC: pro-opiomelanocortin-derived peptides; SP: substance P. (This three-dimensional summary is an updated and modified version of a similar figure published in Palkovits, 1984).

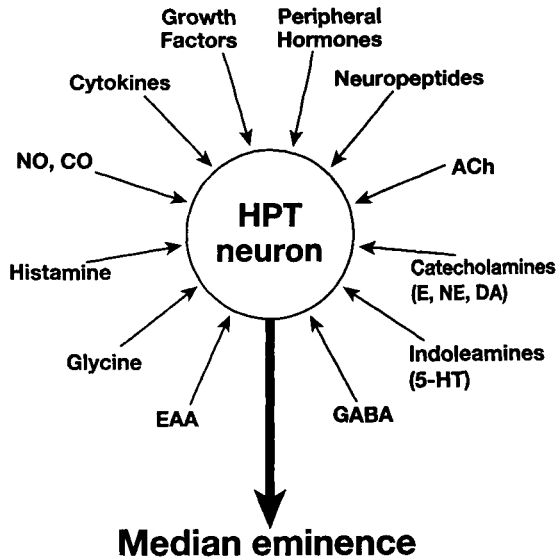

Figure 15. Schematic representation of the connectivity of a “generalized” HPT neuron. The details for each classical HPT hormone-containing neuron are summarized in Table 2.

CONNECTIVITY OF HYPOPHYSIOTROPIC NEURONS: AFFERENTS AND COLOCALIZATION

Afferents of Hypophysiotropic Neurons

As an integral part of the central nervous system, the HPT neuronal system receives neuronal inputs from other HPT and non-HPT neurons. The secreted hormones by the latter group include neuropeptides, catecholamines, indoleamines, γ -aminobutyric acid (GABA), excitatory amino acids, glycine, histamine, growth factors, cytokines, and nitric oxide. Hormones from the peripheral endocrine organs and from the anterior pituitary (gonadotropins, adrenocorticotropin, thyroid-stimulating hormone, growth hormone, and prolactin) also reach the HPT neurons. In many cases, these hormones do not contact the HPT neurons directly; their effect is transmitted indirectly through interneurons. Figure 15 is a schematic representation of the connectivity of a “generalized” HPT neuron. In contrast to the afferents containing neuropeptides and other putative neurotransmitters (Figure 15), the location of catecholamine- and indoleamine-containing perikarya that project to HPT neurons is better delineated (Figure 16). Table 2 summarizes the details of afferentation for each classical HPT hormone-producing neuron. For details see Hoffman et al., 1992; Lechan et al., 1992; Meister and Hökfelt, 1992; Petrusz and Merchenthaler, 1992; Silverman, 1993.

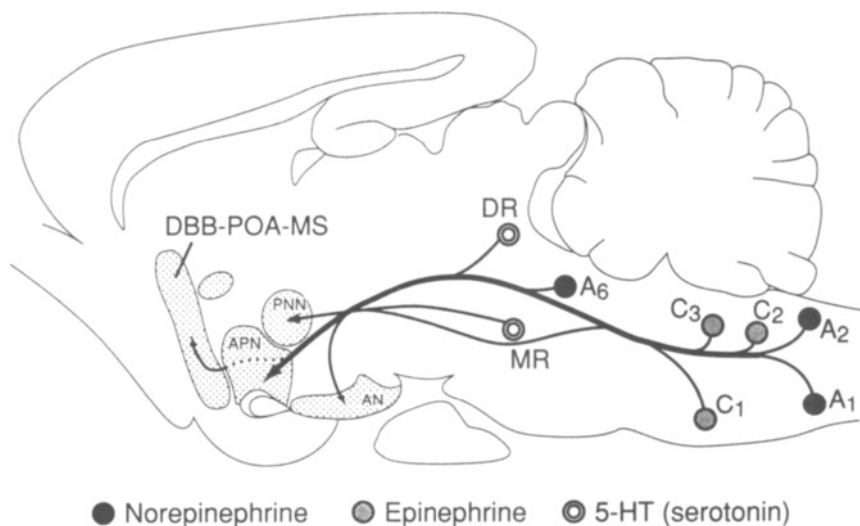

Figure 16. Schematic illustration of afferents to HPT areas containing catecholamines (norepinephrine and epinephrine) and indoleamine (serotonin). DBB-POA-MS: diagonal band of Broca-medial preoptic area-medial septum; APN: anterior periventricular nucleus; PVN: paraventricular nucleus; AN: arcuate nucleus; DR: dorsal raphe; MR: raphe magnus; A₁, A₂, A₆: norepinephrine-producing cell groups; C₁-C₃: epinephrine-containing cell groups.

Colocalization of Different Factors in Hypophysiotropic Neurons

The coexistence of multiple chemical messengers within the same neuron has been well documented throughout the central nervous system and seems to be the rule rather than the exception. For recent reviews see Hökfelt et al., 1987; Bártfai et al., 1988; Bondy et al., 1989; Kuppermann, 1991. It has been shown that, among the classical HPT factors, GHRH coexists with galanin, neurotensin, and dopamine in the arcuate nucleus (Everitt et al., 1986); CRH with vasopressin, peptide histidine-isoleucine (PHI), VIP, ENKs, angiotensin II, CCK, neurotensin, oxytocin, galanin, and GABA in the paraventricular nucleus (Hökfelt et al., 1987); LHRH with galanin in the diagonal band of Broca and medial preoptic area (Merchenthaler et al., 1991) and with delta sleep-inducing peptide (DSIP) in every region in which LHRH-containing neurons are present (Charnay et al., 1990); and dopamine with GHRH, NPY, enkephalins, dynorphins, galanin, neurotensin, GABA and acetylcholine in the arcuate nucleus (Everitt et al., 1986). The colocalization of TRH and SRIF with other transmitters in HPT areas is not known. Figures 18 and 19 summarize the details of colocalization.

Table 2. Connectivity of Classical Peptidergic HPT Neurons

	<i>CRH</i>	<i>GHRH</i>	<i>LHRH</i>	<i>SRIF</i>	<i>TRH</i>
Catecholamines					
Dopamine	+	+	+	+	+
Epinephrine	+	+	+	+	+
Norepinephrine	+	+	+	+	+
Indoleamines					
5-Hydroxytryptamine	+	+	+	+	+
Acetylcholine	+	-	-	+	+
Neuropeptides					
Angiotensin II	+	-	-	-	-
Brain natriuretic peptide	-	-	-	-	-
Cholecystokinin	-	-	-	-	-
Dynorphins	-	-	-	-	-
Enkephalins	+	-	+	-	-
Galanin	+	+	+	+	?
Glucagon	-	-	-	-	-
Neuropeptide Y	+	+	+	+	+
Neurotensin	-	-	+	-	-
Oxytocin	+	-	-	-	+
POMC	+	-	+	-	?
Somatostatin	-	+	-	+	+
Substance P	-	-	+	-	+
Vasoactive intestinal peptide	-	-	-	-	-
Vasopressin	+	-	-	-	+
Amino acid transmitters					
Aspartate, glutamate GABA, and glycine	?	?	?	?	?
Histamine	+	-	-	-	+
Growth factors	-	-	-	+	-
Interleukins	+	-	-	-	+
Nitric oxide	?	-	?	-	?
Peripheral hormones					
Estradiol	-	-	?	-	-
Progesterone	-	-	?	-	-
Testosterone	-	-	?	-	-
Glucocorticoids	+	-	-	-	-
Mineralocorticoids	+	-	-	-	-
Thyroxin	-	-	-	-	+
Inhibin	-	-	-	-	-

Notes: +: Morphological and/or pharmacological evidence; -: not known or does not exist; ?: contradictory observations

Colocalization of different substances in the same perikaryon is not a phenomenon found in every cell; the incidence of colocalization and the intensity of staining of substances vary under different physiological and pharmacological circumstances. For example, in the absence of glucocorticoids, achieved by adrenalectomy, CRH-containing neurons in the paraventricular nucleus synthesize and secrete vasopressin, indicating that glucocorticoids normally suppress vasopressin gene expression (Bondy et al., 1989). On the other hand, estradiol increases galanin gene expression in most tissues (Gabriel et al., 1990) and initiates the expression of galanin within LHRH-containing perikarya (Merchenthaler et al., 1990). However, this action of estradiol is sexually dimorphic in the LHRH-containing neuronal system where the number of LHRH-immunoreactive perikarya colocalizing galanin is fivefold higher in female than male rats (Merchenthaler et al., 1992). Lactation provides another example of the plasticity of coexpression. The high

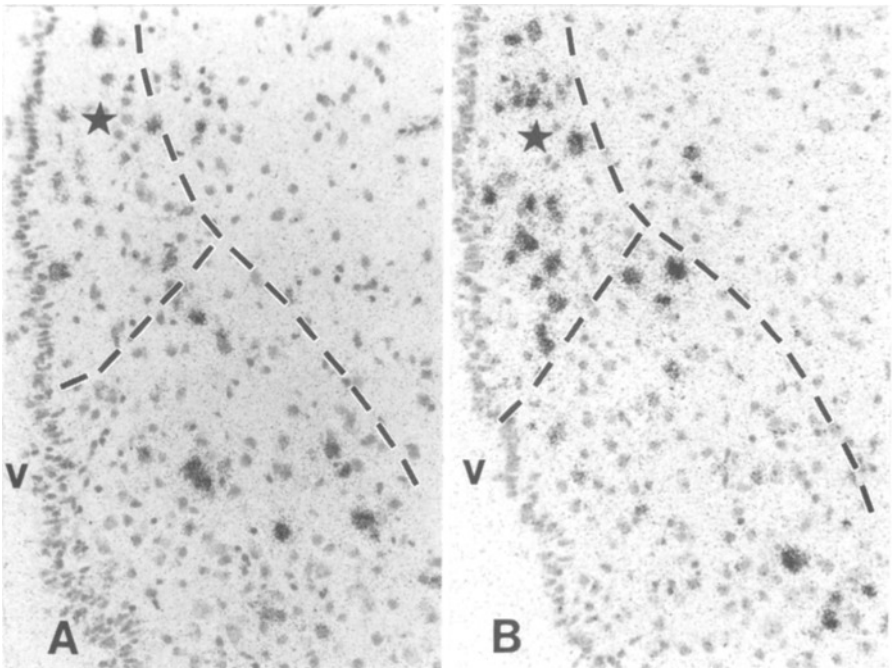

Figure 17. Pro-enkephalin mRNA-containing perikarya in the arcuate nucleus detected by *in situ* hybridization histochemistry using a ^{35}S -labeled riboprobe. Note that in the cycling female rat the dorsomedial subdivision (*star*) contains only a few labeled cells while in the lactating rat there are a large number of perikarya expressing pro-ENK mRNA. Pro-ENK in these perikarya is colocalized with dopamine, neurotensin, GABA, galanin, and dynorphins (see also Figure 19).

prolactin serum levels during lactation are associated with elevated progesterone and low estradiol concentrations. Under these conditions, the tuberoinfundibular dopaminergic (TIDA) neurons produce ENKs (Figures 7B and 17) and probably dynorphin, in addition to neurotensin, GABA and galanin (Merchenthaler, 1993). Neither ENK nor dynorphin and their mRNAs (Figure 17) are present in these neurons of cycling female or male rats. The critical function of prolactin is supported by the evidence that TIDA neurons of pregnant, pseudopregnant and aged rats, each exhibiting elevated serum prolactin levels, also produce ENKs and dynorphins. In addition, when prolactin is eliminated from a lactating animal

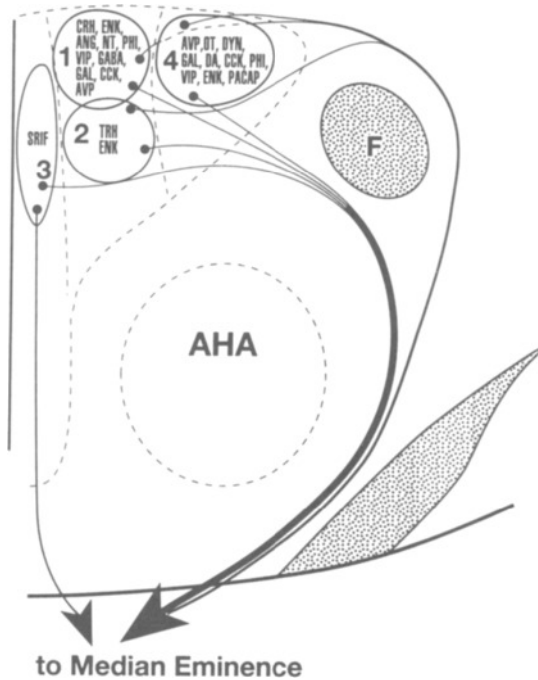

Figure 18. Colocalization of HPT and non-HPT hormones in the paraventricular nucleus (PVN). The subnuclei of the PVN are indicated by Arabic numbers. CRH in the medial parvicellular subnucleus (1) is colocalized with a large number of peptides and GABA. In a few perikarya of the medial parvicellular subnucleus (2), TRH is colocalized with enkephalins (ENK). In the periventricular subnucleus (3), SRIF does not show colocalization. In the magnocellular subdivisions (4), several peptides are colocalized. Most of these neurons project to the posterior lobe of the pituitary; some of them, however, form nerve terminals on capillaries of the hypophysial portal system. Axons from most of the perikarya reach the median eminence in a fan-shaped projection. Axons from a small portion of periventricular neurons run parallel with the ventricular wall. F: fornix; AHA: anterior hypothalamic area.

experimentally, by hypophysectomy or pharmacological treatment, enkephalins and dynorphins and their corresponding mRNAs “disappear” from these neurons (Merchenthaler, unpublished observations). Although recent observations support the key role of prolactin, they also emphasize the supportive role of progesterone in the colocalization phenomenon (Merchenthaler et al., 1995).

While colocalization of HPT hormones with other HPT hormones, neuropeptides, and neurotransmitters is a common phenomenon, the physiological significance of this type of communication and the mechanism underlying differential

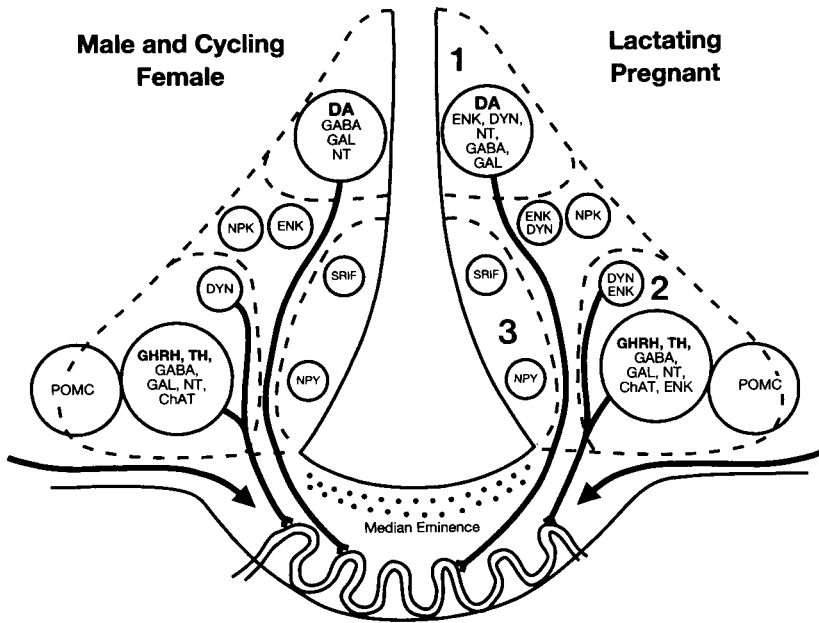

Figure 19. Colocalization of HPT and non-HPT hormones in subnuclei of the arcuate nucleus in male and cycling female rats (*left side*) and lactating and pregnant rats (*right side*). Note that ENK and DYN are coexpressed with dopamine within the dorsomedial subnucleus (1) of the arcuate nucleus of lactating or pregnant rats. GHRH in the ventrolateral subdivision (2) is colocalized with several peptides and tyrosine hydroxylase; however, dopamine is not synthesized by these neurons (Everitt et al., 1986). SRIF and NPY in the ventromedial subdivision (3) is produced by neurons that do not project to the median eminence. Although most of the neurons in the ventrolateral subdivision (2) contact the portal circulatory system, POMC-containing neurons do not send their processes to the median eminence. The scattered ENK-, DYN-, and neuropeptide K (NPK)-containing neurons in the area among the main subdivisions are believed not to be hypophysiotropic. Thick solid lines represent axonal pathways to the median eminence from the arcuate nucleus or other forebrain areas.

gene expression are not well understood. Because it is extremely difficult to study the physiological significance of colocalization of multiple messenger molecules in the central nervous system, most of the published results are from experiments performed on the peripheral nervous system (Hökfelt et al., 1987). There are examples, however, even in the central nervous system, in which the physiological significance of colocalization seems to be well established. Observations in both the central and peripheral nervous systems suggest the existence of stimulatory or inhibitory action of multiple messenger molecules at pre- and postsynaptic sites. For details see Kuppermann (1991).

The colocalizations of CRH and vasopressin in the paraventricular nucleus and of LHRH and galanin in the anterior hypothalamus are of considerable interest, since the synergistic actions of CRH and vasopressin on ACTH secretion and LHRH and galanin on LH secretion are two of the few examples in which the physiological significance of colocalization appears established. In contrast, the interaction of dopamine with the two classes of endogenous opioid peptides (enkephalins and dynorphins) is antagonistic to prolactin secretion. Dopamine is considered to be the physiological prolactin release-inhibiting factor (PIF), and enkephalins and dynorphins are peptides with prolactin-releasing activity. The same neuron, therefore, produces two chemically (dopamine: catecholamine; enkephalins and dynorphins: peptides) and functionally different groups of substances. It is possible that, during lactation, when the positive feedback action of prolactin on dopamine release is suspended so that more prolactin is released, the two other colocalizing partners with prolactin-releasing activity maintain elevated prolactin synthesis readily available upon the suckling stimulus.

The results of studies of the colocalization of multiple HPT factors have led to some general conclusions: (1) not every HPT hormone-producing neuron shows 100% colocalization with other HPT hormones—rather, only a subpopulation of neurons contains one or more of them; (2) none of the classical HPT hormones is colocalized with another classical HPT hormone; and (3) chemical plasticity of the HPT neurons is a common feature—i.e., the extent of coexpression varies with hormonal status. The colocalization phenomenon seems to be a brilliantly economic solution in the nervous system. Without rewiring, the same anatomical network is able to function differently minute by minute, depending on the neuronal and humoral milieu of the HPT neuron. The disadvantage of colocalization of multiple messengers for the scientist and the physician is that, since the neurons release a cocktail with the proportion of the ingredients exhibiting dynamic change, it is not yet possible to provide a mixture of agonists or antagonists to manipulate precisely any of these systems. The colocalization of classical HPT factors with nonclassical HPT factors and/or neurotransmitters in the paraventricular and arcuate nuclei is schematically represented in Figures 18 and 19.

CONCLUSIONS

Classical and nonclassical HPT neurons contain chemical messengers which, depending on the site of their release, behave as HPT hormones or neurotransmitters. The techniques necessary to identify these HPT and non-HPT neurons are available and intensive work in the near future is anticipated. The majority of the HPT neurons coexpress other HPT factors or neurotransmitters. However, the classical HPT hormone-producing neurons do not coexpress another classical HPT hormone. The need for understanding the physiological significance of colocalization of multiple messengers and the mechanism by which the multiple genes are regulated is acute. Considerable research can also be expected in this area. Mapping of the afferents and receptors of HPT neurons requires laborious electron microscopic and immunocytochemical analysis. Much effort will be required to study the role of nitric oxide (NO) and carbon monoxide (CO), two gaseous neurotransmitter candidates, in the regulation of the activity of HPT neurons. All the available data indicate that the function of the anterior pituitary is regulated primarily by the classical HPT hormones. Although the role of the nonclassical HPT factors appears to be secondary, these factors are necessary for the normal functioning of the endocrine system. Therefore, better understanding of the regulation of anterior pituitary function requires more detailed morphological, physiological, and pharmacological studies of both the classical and nonclassical HPT systems.

ACKNOWLEDGMENTS

The author is grateful to Drs. J.L. Maderdrut, F.J. López, and JoAnne Reid for critically evaluating the manuscript.

NOTES

1. The "hypophysiotropic area" was originally defined as those regions of the hypothalamus which maintain or nourish the secretory activity of ectopic anterior pituitary grafts (Halász, 1969). Other investigators have used regulation of the intact anterior pituitary as the critical end point. The operational definition of "hypophysiotropic neuron" used in this chapter is any neuron that contacts capillaries of the hypophysial portal circulatory system, i.e., that can be labeled retrogradely from the external zone of the median eminence. These neurons are called "hypophysiotropic" even if evidence is lacking that any of their putative secretory substances regulate anterior pituitary function, or if no putative secretory substance has yet been localized to their perikarya. This definition is strictly anatomical; its physiological relevance remains to be determined.

2. The organization of the hypophysial portal circulation is similar to the circulation of the liver. The portal vein collects blood from capillaries of unpaired visceral organs, i.e., the intestines, pancreas, and spleen. The portal vein enters the liver via the porta hepatis, the gate of the liver. Inside, these veins branch into capillaries again through which nutrients from the intestines can reach liver cells. For details see Ambach and Palkovits (1979) and Page (1993).

3. The hypophysial portal circulation appears first during phylogenesis in amphibia. In lower vertebrates, such as fish, axons of the HPT neurons directly "innervate" pituitary cells. The released HPT hormone reaches the target pituitary cell(s) via the intercellular space.

4. The presence of a chemical messenger in the ME is frequently based on radioimmunoassay measurements from the entire ME, including the internal and external zones. Thus, since some of these messengers may be present in fibers of the internal zone but not in nerve terminals of the external zone, they do not have hypophysiotropic functions.

REFERENCES

- Ambach, G., & Palkovits, M. (1979). The blood supply of the hypothalamus. In: *Anatomy of the Hypothalamus* (Morgane, P.J., & Panksepp, J., Eds.), Vol. 1, pp. 267–377. Marcel Dekker, New York.
- Bártfai, T., Iverfeldt, K., Fisone, G., & Serfözö, P. (1988). Regulation of the release of coexisting neurotransmitters. *Ann. Rev. Pharmacol. Toxicol.* 28, 285–310.
- Bondy, C.A., Whitnall, M.H., Brady, L.S., & Gainer, H. (1989). Coexisting peptides in hypothalamic neuroendocrine systems: some functional implications. *Cell. Mol. Neurobiol.* 250, 427–446.
- Charnay, Y., Bouras, C., Vallet, P.G., Golaz, J., Guntern, R., & Constantidinis, J. (1989). Immunohistochemical colocalization of DSIP and LHRH in rabbit neurons. *Neuroscience* 31, 495–505.
- Everitt, B.J., Meister, B., Hökfelt, T., Melander, T., Terenius, L. et al. (1986). The hypothalamic arcuate nucleus-median eminence complex: Immunohistochemistry of transmitters, peptides and DARP-32 with special reference to coexistence in dopamine neurons. *Brain Res. Rev.* 11, 97–155.
- Everitt, B.J., Meister, B., & Hökfelt, T. (1992). The organization of monoaminergic neurons in the hypothalamus in relation to neuroendocrine integration. In: *Neuroendocrinology* (Nemeroff, C.B., Ed.), pp. 87–128. CRC Press, Boca Raton, FL.
- Flerkó, B., Merchenthaler, I., & Sétáló, G. (1986). Short and ultrashort feedback control of gonadotropin secretion. In: *Endocrinology and Physiology of Reproduction* (Leung, P.C.K., Armstrong, D.T., Ruf, K.B., Moger, W.H., & Friesen, H.G., Eds.), pp. 37–50. Plenum Press, New York.
- Gabriel, S.M., Koenig, J.I., & Kaplan, L.M. (1990). Galanin-like immunoreactivity is influenced by estrogen in peripubertal and adult rats. *Neuroendocrinology* 51, 168–173.
- Halász, B. (1969). The endocrine effects of isolation of the hypothalamus from the rest of the brain. In: *Frontiers in Neuroendocrinology* (Ganong, W.F., & Martini, L., Eds.), pp. 307–342. Oxford University Press, London.
- Hoffman, G.E., Lee, W.-S., & Wray, S. (1992). Gonadotropin releasing hormone (GnRH). In: *Neuroendocrinology* (Nemeroff, C.B., Ed), pp. 185–218. CRC Press, Boca Raton, FL.
- Hökfelt, T., Tsuruo, Y., Meister, B., Melander, T., Schalling, M., & Everitt, B. (1987). Localization of neuroactive substances in the hypothalamus with special reference to coexistence of messenger molecules. *Adv. Exp. Med. Biol.* 219, 21–45.
- Kuljis, R.O., & Advis, J.P. (1989). Immunocytochemical and physiological evidence of a synapse between dopamine- and luteinizing hormone-releasing hormone-containing neurons in the ewe median eminence. *Endocrinology* 124, 1579–1581.
- Kuppersmann, I. (1991). Functional studies of cotransmission. *Physiol. Rev.* 71, 683–732.
- Lechan, R.M., Nestler, J.L., & Jacobson, S. (1981). Immunohistochemical localization of retrogradely and anterogradely transported wheat germ agglutinin (WGA) within the central nervous system of the rat. *J. Histochem. Cytochem.* 29, 1255–1262.
- Lechan, R.M., & Toni, R. (1992). Thyrotropin-releasing hormone neuronal systems in the central nervous system. In: *Neuroendocrinology* (Nemeroff, C.B., Ed), pp. 279–332. CRC Press, Boca Raton, FL.
- Meister, B., & Hökfelt, T. (1992). The somatostatin and growth hormone-releasing factors systems. In: *Neuroendocrinology* (Nemeroff, C.B., Ed), pp. 219–278. CRC Press, Boca Raton, FL.
- Merchenthaler, I. (1991). Current status of brain hypophysiotropic factors. Morphological aspects. *Trends Endocr. Metabol.* 2, 219–226.

- Merchenthaler, I. (1990). Retrograde labeling of hypophysiotropic neurons by local injection of wheat germ agglutinin (WGA) into the median eminence or peripheral administration of Fluoro-Gold. *Mol. Cel. Neurosci.* 1, 93–106.
- Merchenthaler, I., Kovács, G., Lovász, G., & Sétáló, G. (1980). The preoptico-infundibular LHRH tract of the rat. *Brain Res.* 198, 63–74.
- Merchenthaler, I., Görcs, T., Sétáló, G., Petrusz, P., & Flerkó, B. (1984). Gonadotropin releasing hormone (GnRH) neurons and pathways in the rat brain. *Cell Tissue Res.* 237, 15–29.
- Merchenthaler, I., Csontos, C., Sétáló, G., Petrusz, P., Flerkó, B., & Negro-Vilar, A. (1989). Combined retrograde tracing and immunocytochemical identification of luteinizing hormone-releasing hormone- and somatostatin-containing neurons projecting to the median eminence of the rat. *Endocrinology* 125, 2812–2821.
- Merchenthaler, I., López, F.J., & Negro-Vilar, A. (1990). Co-localization of galanin and luteinizing hormone-releasing hormone (LHRH) in a subset of preoptic neurons. Anatomical and functional correlates. *Proc. Natl. Acad. Sci. USA* 87, 6326–6630.
- Merchenthaler, I., López, F.J., Lennard, E.D., & Negro-Vilar, A. (1992). Sexual differences in the distribution of neurons coexpressing galanin and luteinizing hormone-releasing hormone in the rat brain. *Endocrinology* 129, 1977–1986.
- Merchenthaler, I., Lennard, D.E., Cianchetta, P., Merchenthaler, A., & Bronstein, D. (1995). Induction of proenkephalin in tuberoinfundibular dopaminergic neurons by hyperprolactinemia: The role of sex steroids. *Endocrinology* 136, 2442–2450.
- Page, R.B. (1988). The anatomy of the hypothalamo-hypophyseal complex. In: *The Physiology of Reproduction* (Knobil, E., & Neill, J.D., Eds.), pp. 1161–1233. Raven Press, New York.
- Palkovits, M. (1984). Neuropeptides in the hypothalamo-hypophyseal system: Lateral retrochiasmatic area as a common gate for neuronal fibers towards the median eminence. *Peptides* 5(suppl.), 35–39.
- Palkovits, M. (1986). Neuropeptides in the median eminence. *Neurochem. Int.* 9, 131–139.
- Petrusz, P., & Merchenthaler, I. (1992). The corticotropin-releasing factor system. In: *Neuroendocrinology* (Nemeroff, C.B., Ed), pp. 129–184. CRC Press, Boca Raton, FL.
- Piva, F., Motta, M., & Martini, L. (1979). Regulation of hypothalamic and pituitary function: Long, short, and ultrashort feedback loops. In: *Endocrinology* (deGroot, J.L., Cahil, J.F., Odell, W.D., Martin, T., Potts, J.T., Nelson, D.H., Steinburger, F.E., & Winegard, A.I., Eds.), pp. 21–33. Grune & Stratton, New York.
- Silverman, A.-J. (1988). The gonadotropin releasing hormone neuronal systems: immunocytochemistry. In: *The Physiology of Reproduction* (Knobil, E., & Neill, J.D., Eds.), pp. 1283–1304. Raven Press, New York.
- Szentágothai, J., Flerkó, B., Mess, B., & Halász, B. (1962). In: *Hypothalamic Control of the Anterior Pituitary*. Publishing House of the Hungarian Academy of Sciences, Budapest.

RECOMMENDED READINGS

- Harris, G.E. (1948). Neuronal control of the pituitary gland. *Physiol. Rev.* 28, 139–179.
- Knobil, E., & Neill, J.D. (Eds.) (1994). *The Physiology of Reproduction*. Raven Press, New York.
- Morgane, P.J., & Panksepp, J. (Eds.) (1979). *Anatomy of the Hypothalamus*, Vol. 1. Marcel Dekker, New York.
- Nemeroff, C.B. (Ed.) (1992). *Neuroendocrinology*. CRC Press, Boca Raton, FL.
- Reichlin, S. (1985). *Neuroendocrinology* In: *Textbook of Endocrinology*, 7th edn. (Wilson, J.D., & Foster, D.W., Eds.). W.B. Saunders, Philadelphia.

Chapter 5

The Pineal Gland

RUSSEL J. REITER

Introduction	145
Pineal Morphology and Innervation	146
Melatonin Levels in Blood and Other Body Fluids	151
Melatonin Receptors/Binding Sites	156
Physiological Consequences of Melatonin	156
Summary	161

INTRODUCTION

The pineal gland, also called the epiphysis cerebri, was thought to be essentially non-functional until several important findings in the early 1960s revealed that the pineal gland is highly metabolically active (Axelrod et al., 1965) and that it exerts considerable control over reproductive physiology (Hoffman and Reiter, 1965). Since these early observations, knowledge of the cell biology of the pineal (Reiter, 1991) and of its physiological interactions (Bartness et al., 1994) has accumulated at a rapid pace. It is now clear that this endocrine gland, which for so many years labored in obscurity, may be the most widely acting gland in the body. There is little

Principles of Medical Biology, Volume 10A
Molecular and Cellular Endocrinology, pages 145–164.
Copyright © 1997 by JAI Press Inc.
All rights of reproduction in any form reserved.
ISBN: 1-55938-815-3

doubt that the major endocrine product of the pineal gland, melatonin, besides readily entering cells and subcellular compartments, easily passes through all morphophysiological barriers, e.g., the blood–brain barrier, and exerts actions that modify primary intracellular events.

This chapter reviews the anatomy of the pineal gland which is pertinent to understanding its endocrine status, it summarizes the cell biology of the metabolic events in the organ which culminate in production of the pineal hormone melatonin, and it describes the endocrine and metabolic consequences of melatonin after its release from the pineal gland. While length constraints on the chapter made it impossible to comprehensively cover each issue, the references cited, as well as the list of recommended reading material, will lead the interested reader to more detailed accounts of each of the subjects.

PINEAL MORPHOLOGY AND INNERVATION

The human pineal gland is an evagination of the posterodorsal diencephalon and, while it varies greatly in size from one individual to another, its average weight is roughly 120 mg. There is no gender difference in the size of the human pineal gland.

The pineal, in its definitive position, lies above the mesencephalic tectum and between the superior colliculi (Figure 1). It is surrounded by the coalescing internal cerebral veins which drain into the vein of Galen and eventually into the straight sinus. The base of the gland is invaginated by a protrusion of the third ventricle, the pineal recess. Although not a widely accepted view, there are those who hold the idea that the endocrine products of the pineal gland are released directly into the cerebrospinal fluid via the pineal recess. Most scientists, however, subscribe to the view that the pineal gland releases its product(s) primarily, if not exclusively, into the capillaries within the organ.

Histologically and ultrastructurally the primary cell type in the pineal is what is referred to as the pinealocyte, the hormone-producing cells of the gland (Vollrath, 1991). The pinealocyte has one or more short processes which terminate in the perivascular spaces surrounding capillaries in the gland. Typical secretory granules, which are common in secretory cells of other endocrine organs, are rare or absent in the pineal gland. Yet, the pinealocyte processes, which end in the vicinity of intrapineal capillaries, generally transport and release melatonin after which it quickly enters the systemic circulation. Evidence of the release of melatonin directly into the capillaries that perfuse the gland is provided by the observation that blood, collected from the veins surrounding the pineal gland, contains much higher concentrations of melatonin than does peripheral blood (Cozzi et al., 1988). Like many other hormones, melatonin may be released in a pulsatile (episodic) manner from the gland (English et al., 1987; Cozzi et al., 1988).

The blood supply to the pineal gland is very perfuse (Vollrath, 1981). On the basis of the numerous capillaries that reach the organ, morphologists were claiming it must be an endocrine organ well before its hormonal capabilities were described.

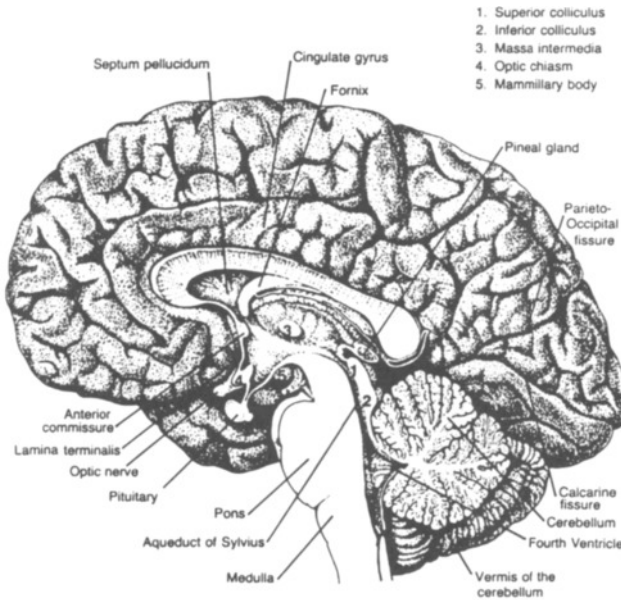

Figure 1. Mid-sagittal cut of the human brain showing the location and anatomical relationships of the pineal gland.

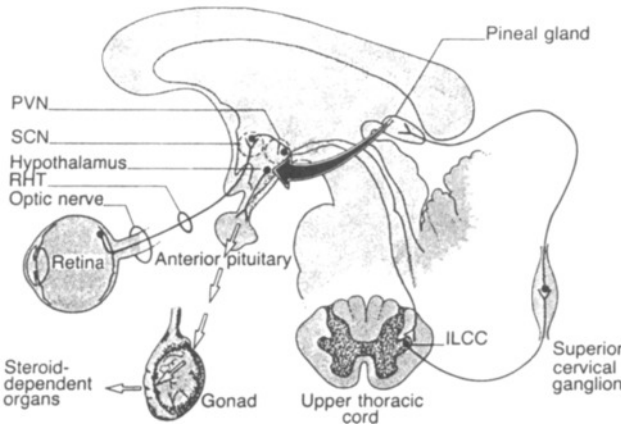

Figure 2. Anatomical connections between the eyes and the pineal gland. Neurons include those in the retinohypothalamic tract (RHT) which synapse in the suprachiasmatic nuclei (SCN), fibers projecting from the SCN to the paraventricular nuclei (PVN), fibers that end in the intermediolateral cell column (ILCC) of the thoracic cord and pre- and postganglionic fibers in the peripheral sympathetic nervous system.

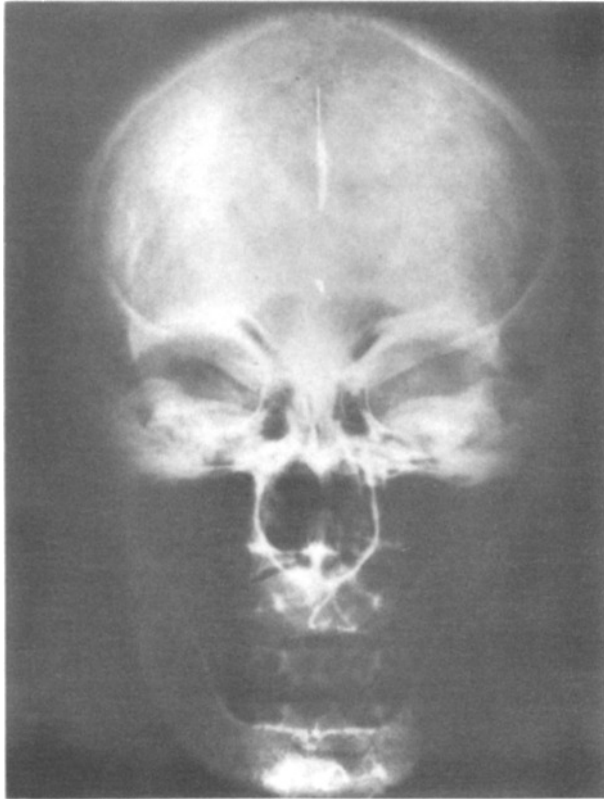

Figure 3. Not uncommonly, the pineal gland (represented by the white spot near the center of the skull) becomes calcified during aging. The deposition of calcium in the gland does not seem to impair its function. In this individual the tentorium cerebri are also calcified (the vertical white line above the pineal gland).

A rich blood supply is a feature common to all endocrine glands. The blood supply is provided by the posterior choroidal arteries which are branches of the posterior cerebral arteries of the vertebrobasilar artery system.

Unlike other endocrine organs, the pineal gland is highly dependent on innervation for its function. The primary factor determining the synthetic and secretory activity of the pineal gland is the prevailing light: a dark environment which is perceived by the eyes (Reiter, 1991). After its transduction into a neural message at the level of the retinas, the information is transferred to the pineal gland over a series of neurons in both the central and peripheral sympathetic nervous system (Figure 2). The pineal is innervated by postganglionic sympathetic fibers whose cell bodies are in the superior cervical ganglia deep to the common carotid artery in the neck. The cell bodies of the preganglionic neurons in this chain are located

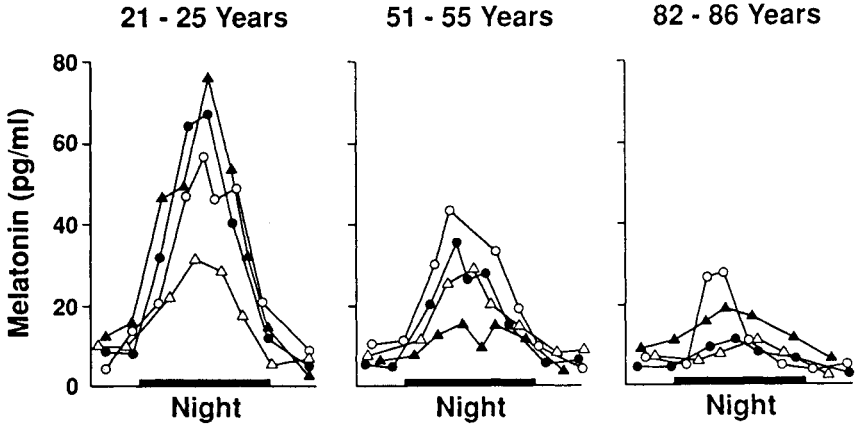

Figure 4. Nocturnal increase in blood melatonin levels in four individuals in each of three age groups. Especially noticeable in the 21–25 year old age group is the marked variation in the nighttime increase in melatonin levels. Intraindividual variations in the amplitude of the nocturnal melatonin peak are small, although interindividual variations are large. The amplitude of the nocturnal melatonin peak decreases with age.

in the intermediolateral cell column of the upper thoracic cord (Figure 2). The preganglionic sympathetic cells receive information about the photoperiodic environment from axons descending from cells at higher centers in the hypothalamus. The hypothalamic cells communicate with neurons in the so-called biological clock, the suprachiasmatic nuclei (SCN), in the anterior hypothalamus. The intrinsic circadian cycle of the SCN is synchronized by light:dark information in axons in the retinohypothalamic tract that originate in the retinas. It is via this complex series of neurons that light, detected by the retinas, regulates the endocrine activity of the pineal gland (Reiter, 1981). The essential nature of the sympathetic innervation of the pineal gland is illustrated by the observations that bilateral superior cervical ganglionectomy renders the pineal unresponsive to photoperiodic information and essentially eliminates the production and secretion of melatonin from the gland. The sympathetic innervation of the pineal gland also regulates the deposition of calcium in acervuli (corpora arenacea) in the pineal gland (Champney et al., 1985). Calcium deposition in the pineal gland (Figure 3), which is commonly associated with aging, seems unrelated to suppression of melatonin production (Puig-Domingo et al., 1992), although this is a common misconception among clinicians.

The chief hormone of the pineal gland is the indoleamine, *N*-acetyl-5-methoxy tryptamine, commonly known as melatonin (Reiter, 1991). It is almost exclusively synthesized and secreted from the pineal gland at night, resulting in a marked nocturnal increase in circulating melatonin levels (Figure 4).

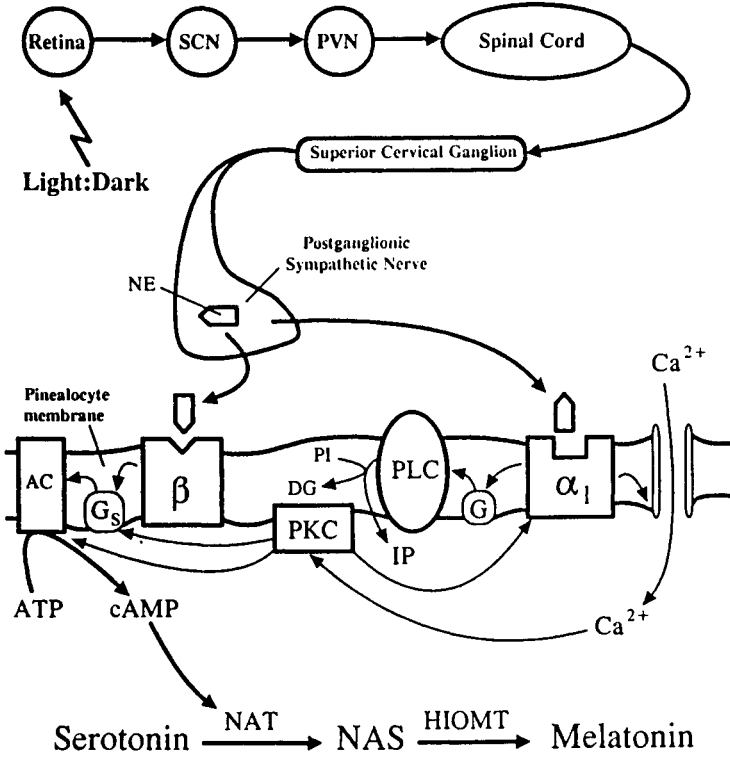

Figure 5. Neural connections between the eyes and the pineal gland and the signal transduction mechanisms in the pinealocyte which mediate the nighttime rise in melatonin production are shown. Norepinephrine (NE) released at night interacts with both β -adrenergic (β) and α -adrenergic (α) receptors to stimulate the conversion of serotonin to melatonin. This pathway is catalyzed by *N*-acetyltransferase (NAT) and hydroxyindole-*O*-methyltransferase (HIOMT) with the intermediate being *N*-acetylserotonin. The intracellular second messenger involved in this process is cyclic AMP (cAMP).

The initiation of pineal melatonin production at night is a consequence of the release of the catecholaminergic neurotransmitter, norepinephrine (NE), from the postganglionic sympathetic neurons which terminate near the pinealocytes. After its release, NE interacts with both β - and α -adrenergic receptors in the pinealocyte membrane (Pangerl et al., 1990). The signal transduction mechanisms by which NE governs nocturnal melatonin production have been described in detail and are summarized in Figure 5 (Reiter, 1991). The rise in the intracellular second messenger, cAMP, induces the activity of the rate limiting enzyme *N*-acetyltransferase (NAT) in melatonin production. NAT *N*-acetylates serotonin (5HT) to form the immediate precursor of melatonin, *N*-acetylserotonin. *N*-acetylserotonin is then

O-methylated by the enzyme hydroxyindole-*O*-methyltransferase (HIOMT), thereby forming melatonin.

The 5HT concentration in the pineal gland far exceeds that in any other organ. It is derived from the amino acid tryptophan which is taken into the pinealocytes from the circulation (Reiter, 1991). Tryptophan is rapidly converted to 5HT. While 5HT is oxidatively deaminated in many organs including the pineal gland, in the pinealocyte 5HT is also *N*-acetylated by the NAT with the resultant formation of *N*-acetylserotonin. Inasmuch as the rise in NAT activity is dependent upon the release of NE from postganglionic neurons and the release of the catechoamine occurs almost exclusively at night, highest NAT activity also is coincident with darkness. The nighttime levels of pineal NAT activity can be 50-fold greater than values measured during the day (Reiter, 1991). Since the activity of the final enzyme in the production of melatonin, i.e. HIOMT, is maintained at high levels throughout the light:dark cycle, once *N*-acetylserotonin is produced it is quickly converted to melatonin. Thus, like NAT activity, melatonin production in the pineal gland of all animals, including the human, is maximal at night.

MELATONIN LEVELS IN BLOOD AND OTHER BODY FLUIDS

As an endocrine organ, the pineal gland is somewhat unconventional in that it does not store any of the hormone it produces. Thus, once melatonin is formed, it rapidly escapes from the pinealocytes by diffusing out of the cells and into the nearby capillaries. The diffusion of melatonin from the pinealocytes is believed to be a consequence of its high lipophilicity, which renders cell membranes essentially inconsequential in terms of the release of melatonin. Thus, there seems to be no specific mechanism governing the release of melatonin; rather, once produced, it merely diffuses out of the cell. Since melatonin is primarily synthesized at night and considering its quick release, blood levels also rise at night and they accurately reflect the synthetic activity of the pineal gland at virtually the same time (Figure 4).

Whereas melatonin concentrations rise in the blood at night, the amplitude of the nocturnal increase varies widely among individuals (see Figure 4). Thus, while some subjects may have nighttime melatonin levels 15 times greater than those measured during the day, in other individuals there may only be a twofold rise in circulating concentrations of the indole. The melatonin rhythm seems to be genetically determined and is highly uniform in an individual (Arendt, 1988). Thus, a person with a robust melatonin rhythm maintains a high amplitude, albeit gradually decreasing, cycle throughout much of his adult life; conversely, an individual with a weak rhythm also displays it throughout adulthood. The different amplitude rhythms, as will be seen below, may relate to a variety of physiological states especially in advanced age.

Melatonin's high lipophilicity not only permits it to enter cells and subcellular compartments with ease (Menendez-Pelaez et al., 1993), but likewise, as mentioned

above, it readily crosses all known morphophysiological barriers. Hence melatonin enters the brain with the same time course with which it is found in other tissues after its exogenous administration. Besides being lipophilic, melatonin is also less hydrophobic than originally thought, exhibiting a solubility of 5×10^{-3} M in aqueous media (Shida et al., 1994). Thus, presumably, melatonin readily moves through cell membranes and within subcellular compartments thereby having access to every portion of every cell. In the final analysis, however, it may not be equally distributed throughout the cell since nuclear binding sites for the indole (Acuña-Castroviejo et al., 1994) may increase the concentration of melatonin within the nucleus (Menendez-Pelaez et al., 1993).

The fact that melatonin so quickly moves about the organism is also reflected in the levels of this hormone in all bodily fluids. Besides an increased concentration

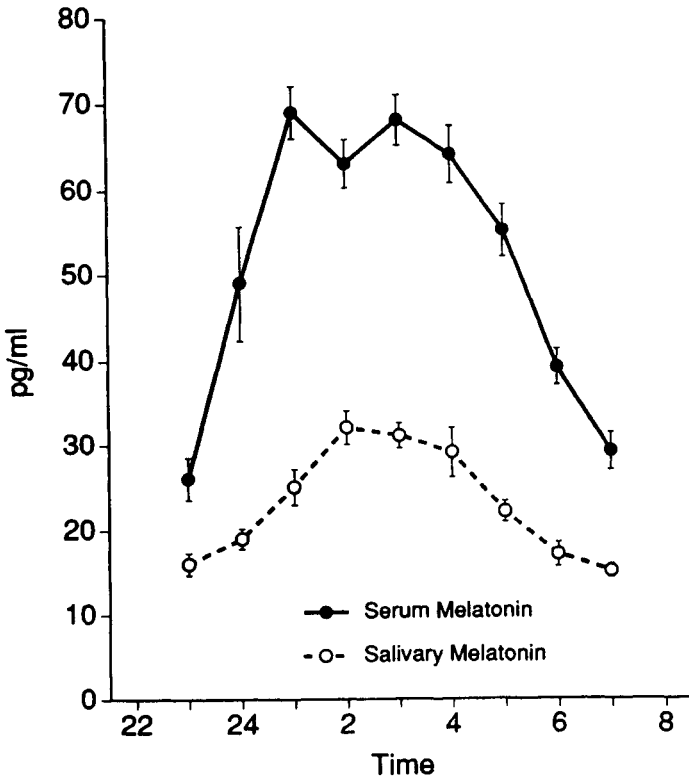

Figure 6. Nocturnal increase in serum and salivary melatonin levels in a group of adult males. The amplitude of the nocturnal peak is lower in the saliva than in the serum; this is true for the rhythm in other fluids as well. Melatonin, released from the pineal gland, enters the blood from which it escapes into all other body fluids. [Redrawn from McIntyre et al. (1987)].

of melatonin in the blood at night, every other fluid in which melatonin has been measured over a 24 hour period exhibits a nighttime rise in the concentration of the indole. Thus, melatonin has been measured in the cerebrospinal fluid, male seminal fluid, ovarian follicular fluid, fluid of the anterior chamber of the eye, and in the saliva. The salivary melatonin rhythm, which is a blood-derived cycle (Figure 6), allows for an unobtrusive way in which to monitor the hormone secreting activity of the pineal gland throughout a light:dark cycle (McIntyre et al., 1987). In most fluids, the concentration of melatonin is lower and the amplitude of the rhythm weaker than they are in the blood (Laakso et al., 1990).

Humans, unlike other animals, have the capability of voluntarily controlling their light:dark environment and, as a consequence, of manipulating their circadian melatonin cycle. Thus, light can be used as a “drug” to either interrupt the melatonin cycle or to change the phasing of its rhythm (Lewy et al., 1980). The exposure of individuals to light at night, when circulating concentrations of melatonin are high, depresses melatonin levels in relation to the brightness of the light (Figure 7) (McIntyre et al., 1989). Also, the imposition of light either in the evening or in the morning can be used to both truncate the duration of nocturnally elevated melatonin, as well as to phase shift (either advance or delay) its rhythm (Lewy and Sack, 1993).

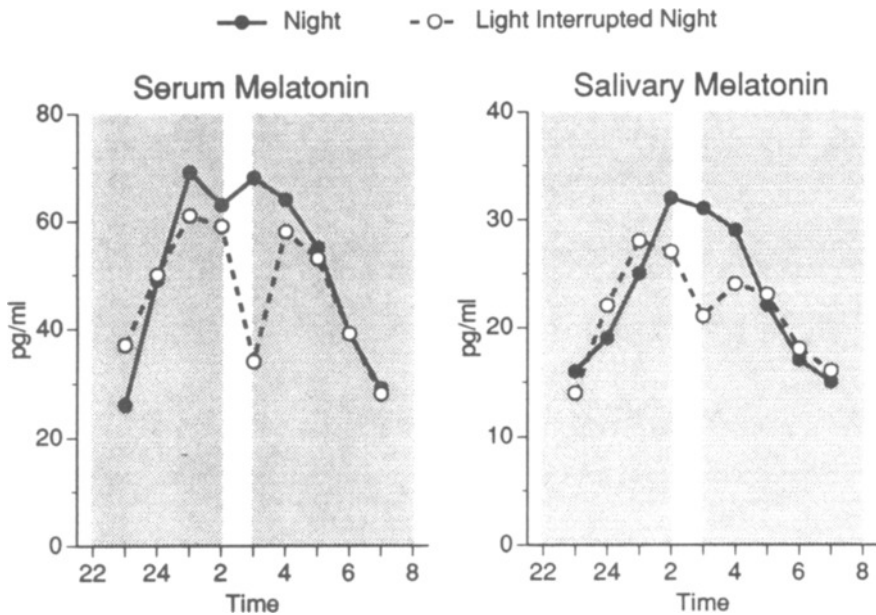

Figure 7. Light exposure at night reduces nighttime levels of melatonin in all body fluids, represented here by the serum and saliva. The brighter the light exposure, the greater the degree of melatonin suppression. Shaded area represents darkness. [Redrawn from McIntyre et al. (1989)].

The use of light to adjust the circadian melatonin rhythm and to thereby alter physiology is referred to as phototherapy. The duration of elevated melatonin is proportional to the duration of the daily dark period (Figure 8) (Wehr, 1991) and, as a result, at the extremes of latitude the night interval of elevated melatonin varies widely with the season of the year (Stokkan and Reiter, 1994). Blind humans who are incapable of any light perception exhibit a free running melatonin rhythm which has a period closer to 25 hours than to 24 hours (Lewy and Newsome, 1983).

The melatonin rhythm is also highly age-dependent. It is generally agreed that at birth newborns lack a melatonin rhythm but that it develops quickly during the early months and that, by the end of the first year, the rhythm probably exhibits its greatest day:night excursions (Reiter, 1991).

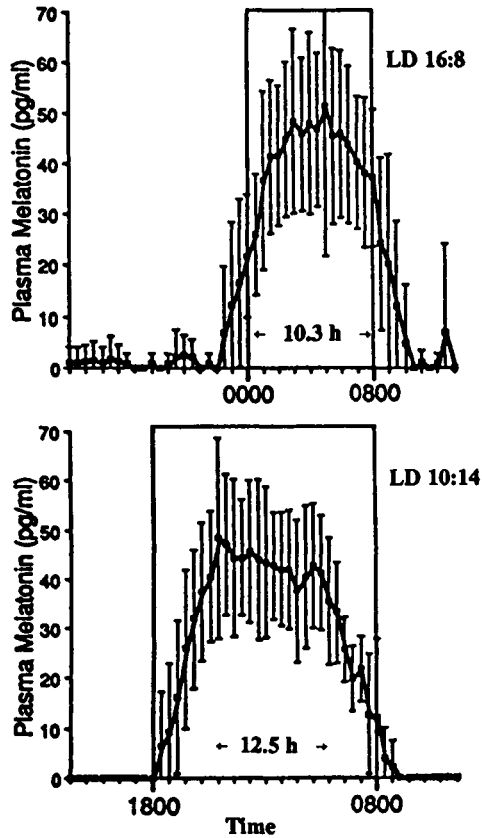

Figure 8. The longer the night period, the longer the duration of elevated melatonin. Here the duration of darkness was either 8 or 14 h and the duration of elevated nocturnal melatonin was 10.3 h and 12.5 h, respectively. [Redrawn from Wehr (1991)].

Throughout childhood the melatonin cycle is highly robust. As individuals progress through puberty, however, there reportedly is a substantial drop in the amplitude of the melatonin rhythm due almost exclusively to the attenuation of the nocturnal increase (Figure 9) (Waldhauser and Steger, 1986). Considering the experimental data implicating melatonin in the control of puberty in experimental animals (Reiter, 1980), it has been proposed that the drop in melatonin levels during sexual maturation may be permissive to sexual development (Waldhauser et al., 1993). After adulthood is attained, the melatonin rhythm is rather stable although, as noted above, its amplitude varies substantially among individuals, while within any one person it is highly stable (see Figure 4). In advanced age the melatonin rhythm gradually deteriorates such that in very old individuals it may be barely discernible (Figure 4). It is not known whether the greatly diminished melatonin rhythm in advanced age is a consequence, a cause, or even related to aging *per se*. In animals, delaying aging by food restriction also delays attenuation of the melatonin cycle (Stokkan et al., 1991).

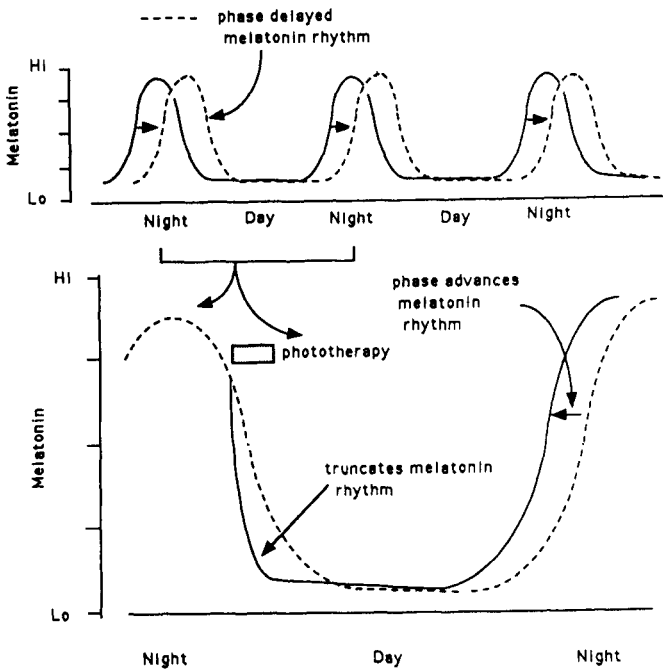

Figure 9. Diagrammatic illustration as to how a phase delayed melatonin rhythm (dashed line) can be adjusted to normal (24-h rhythm) by phototherapy in the early morning. The morning light truncates the melatonin in the morning of treatment and it advances the onset of the subsequent melatonin rise.

MELATONIN RECEPTORS/BINDING SITES

Much of our knowledge of the anatomical location of binding sites has come from data compiled using experimental animals, although it is usually tacitly assumed that the location of these sites in the human will be, or for the most part are, similar to those in non-human mammals. In general, two categories of melatonin binding sites may exist, i.e. membrane and intracellular. The membrane binding sites/receptors have been studied much more extensively and the bulk of these seem to be in the brain, although they are found elsewhere as well (Stankov and Reiter, 1990). Specifically, the membrane receptors for melatonin in the brain and brain-associated areas are most often reported to be in the SCN of the hypothalamus and in the pars tuberalis (PT) of the anterior pituitary. These receptors for the pineal hormone are presumed to convey the effects of the indole on circadian rhythms and on neuroendocrine physiology, respectively. To date, melatonin binding sites have been identified only in the fetal human SCN (Reppert et al., 1988).

The high lipophilicity of melatonin allows it to enter cells essentially unimpeded. Thus, it is not totally unexpected when intracellular binding sites for the indole were also described. Intracellularly, melatonin may bind to calmodulin possibly to exert a variety of metabolic actions (Benitz-King et al., 1993). Furthermore, melatonin binding sites have been reported in hepatic cell nuclei where they are associated with proteins (Acuña-Castroviejo et al., 1994). These sites may exist in many, or all, cells and they may direct genomic actions of the indole. The apparent presence of binding sites for melatonin in the nucleus is consistent with the high concentration of melatonin in this subcellular compartment (Menendez-Palaez et al., 1993).

Besides the intracellular binding sites that may mediate some of melatonin's actions, there is at least one function of melatonin within all cells that requires no receptor molecule. This is its ability to act as a potent oxygen radical scavenger, a function it can carry out just by being in the vicinity of a free radical when it is produced (Reiter et al., 1994). Thus, melatonin's multiple actions may be accomplished by a variety of receptor and nonreceptor mediated mechanisms.

PHYSIOLOGICAL CONSEQUENCES OF MELATONIN

The investigative history of melatonin has repeatedly shown that the hormone has a potent regulatory influence on reproductive physiology (Reiter, 1980). In a variety of photoperiodic mammals, melatonin is known to be an essential intermediate between the environmental light:dark cycle and seasonal reproductive events. Indeed, most of the early work on this hormone linked its primary actions to reproductive physiology so profoundly that much of the other research on the functions of melatonin was overshadowed. Melatonin's regulatory effects on the neuroendocrine-reproductive axis are likely manifested at the level of membrane receptors on the PT cells of the anterior pituitary gland (Carlson et al., 1989). These membrane binding sites are members of the superfamily of G-protein linked

receptors. Exactly how these receptors intervene in the regulation and secretion of hypothalamic gonadotrophin releasing hormone (GnRH) and pituitary gonadotrophins remains unknown.

In humans as well, melatonin may functionally relate to reproductive physiology. The drop in circulating melatonin levels in individuals undergoing sexual maturation has been taken as evidence that the reduction is permissive to normal pubertal progression. A high degree of correlation has been reported to exist between the circulating levels of nighttime melatonin and the Tanner stage of sexual development (Waldhauser and Steger, 1986). This postulate is strengthened by numerous experimental studies where melatonin administration was shown to postpone the onset of puberty in non-human mammals, primarily rodents (Reiter, 1980), and by the recent case report of a male in his third decade of life who did not undergo sexual maturation until his initially abnormally high day and nighttime melatonin levels fell to the normal range (Puig-Domingo et al., 1992). Furthermore, it has long been known that tumors of the pineal gland in prepubertal males (the tumors are rare in females) not uncommonly alter sexual maturation by presumably an endocrine means (Vaughan et al., 1978), possibly involving very high (delayed puberty) or very low (advanced puberty) levels of melatonin (Puig-Domingo et al., 1992). Finally, there are several reports which claim that females with anorexia nervosa, a condition associated with reduced gonadotropins and sexual infantilism, have abnormally elevated circulating patterns of melatonin (Tortosa et al., 1989). However, in none of these cases has it been unequivocally proven that the ability of humans to reach sexual adulthood is contingent upon either the amplitude of the nocturnal melatonin peak or on mean melatonin levels. This theory fails to take into account the possibility that there may be individuals who are merely differentially sensitive to the actions of melatonin in regard to reproductive physiology.

There is clinical evidence suggesting that after adulthood is achieved melatonin may intervene in the regulation of the reproductive system. Thus, a substantial amplification of the melatonin cycle, in terms of both the nighttime melatonin peak and the duration of elevated melatonin, has been reported in women suffering from hypothalamic amenorrhea (Berga et al., 1988). Also, late luteal phase dysphoria (premenstrual syndrome) has been reported to be a consequence of a difference in the circadian melatonin cycle during this interval (Parry et al., 1990). Whether normal menstrual cyclicity is at all influenced by the secretory pattern of melatonin remains under debate, although melatonin is being tested for its contraceptive properties (Voordouw et al., 1992).

In adult males, elevated nocturnal melatonin levels have been reported to be associated with infertility due to aspermia (Karasek et al., 1990) and melatonin in male seminal fluid has been investigated in terms of its potential effects on sperm motility. The results of these studies are inconclusive and the association of melatonin with altered reproductive physiology after adulthood in the human remains unclear.

Very little is known about the melatonin rhythm during female menopause although there is nothing to suggest a relationship between midage reproductive failure and an alteration in the melatonin cycle. In advanced age, females, like males, have a greatly attenuated melatonin rhythm that may be consequential in terms of some other age-related conditions (Reiter et al., 1994).

Besides the obvious effects on neuroendocrine-reproductive function in animals, essentially all of the pituitary hormones have been shown to be influenced by melatonin. Whether this is also true for humans remains, for the most part, untested in any systematic way (Miles et al., 1988).

The presence of membrane melatonin receptors on cells in the SCN, the organism's biological clock, suggests a role for the indole in circadian rhythms. Again, in animals this is unequivocally the case and in humans it also seems to be so. Melatonin has been successfully used to treat "jet lag," a condition which requires adjustments of underlying circadian rhythms (Arendt et al., 1987). Also melatonin administration to profoundly blind humans, whose endogenous melatonin cycle runs with a period of greater than 24 hours (Lewy and Sack, 1986), influences this rhythm probably by an action on the SCN. A similar adjustment of what is referred to as a phase-delayed melatonin rhythm occurs when individuals are given melatonin at the appropriate circadian time (Lewy and Sack, 1993).

The ability of melatonin to synchronize circadian rhythms may relate to the action of this hormone on sleep as well (Dawson and Encel, 1993). The sleep-inducing properties of melatonin are being widely tested and some melatonin concoctions will likely be available for use in the near future (Dollins et al., 1994). Sleep deterioration in the elderly may in part be related to the loss of a robust melatonin rhythm which is a normal consequence of aging (Reiter, 1992; Dawson and Encel, 1993).

Some psychological disorders, in particular seasonal affective disorder (SAD) of the winter subtype (Rosenthal et al., 1984), probably involves a disturbance of circadian rhythms including possibly a phase-delayed melatonin rhythm. As a result, bright light therapy (commonly called phototherapy), usually but not always given in the early morning, is used in the treatment of this disorder (Figure 9). Properly timed phototherapy is known to change the onset of the nocturnal melatonin rise as well as to synchronize other biological rhythms. While phototherapy often greatly improves the psychological status of SAD patients, how much of the improvement is specifically related to an adjustment of the melatonin cycle remains unknown (Lewy and Sack, 1993).

Besides its possible association with SAD, melatonin may relate to a number of other psychological disorders. For example, a condition referred to as low melatonin syndrome or depressive hypomelatoninemia has been described (Wetterberg et al., 1990) and individuals suffering from paranoid schizophrenia (but who are drug free) have been described as having a greatly dampened or totally absent blood melatonin rhythm (Figure 10) (Monteleone et al., 1992).

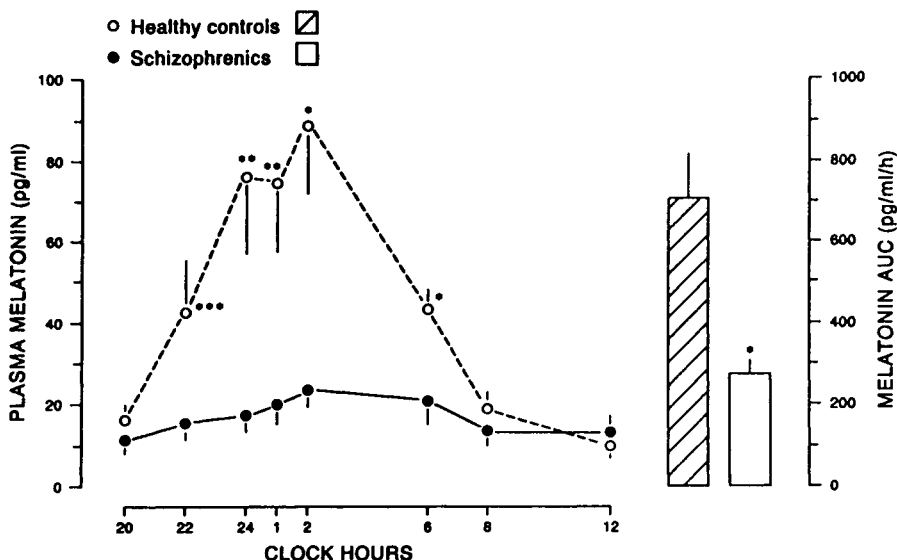

Figure 10. Plasma melatonin levels in normal controls and drug-free schizophrenics. ***p < 0.05, **p < 0.01 and *p < 0.001. AUC, area under the curve. [From Monteleone et al. (1992)].

However, whether the observed alterations of the melatonin cycle in these subjects are a cause, an effect, or even related to the psychological conditions described remains to be proven.

The antiaging potential of melatonin is a theme that is of current interest to scientists working in this field. The possible relationship of aging or age-related diseases to melatonin stems primarily from the observations that the melatonin cycle severely degenerates with advancing age (see Figure 4) (Reiter, 1992). Further, in animals one treatment, i.e. caloric restriction, that delays senescence also preserves the endogenous melatonin cycle in a relatively youthful state (Stokkan et al., 1991). More recently, the administration of melatonin to mice in their drinking water has been shown to prolong survival by more than 10% (Pierpoali and Regelson, 1994).

Whereas several theories have been advanced to explain the postponement of aging by melatonin (Armstrong and Redman, 1991; Grad and Rosencwaig, 1993; Poeggeler et al., 1993), the most compelling argument for the life-maintaining effect of melatonin may come from the discovery that melatonin counteracts oxygen radical toxicity (Tan et al., 1993). Thus, for example, melatonin was found to be an extremely potent hydroxyl radical scavenger (Tan et al., 1993). When compared to other well-known free radical quenchers, such as glutathione and mannitol, melatonin proved to be 5 times and 14 times more efficacious, respec-

tively (Figure 11). This is particularly significant because of the oxygen-based radicals produced in an organism, the hydroxyl radical being considered the most toxic (Halliwell and Gutteridge, 1992). It severely damages all cellular macromolecules and, if the damaged sites go unrepaired, they accumulate. The accumulation of free radical damage may contribute significantly to aging, as well as to a variety of age-related diseases (Herman, 1992).

Melatonin's hydroxyl radical scavenging activity may be especially important in relation to nuclear DNA since its concentration is greatest in this subcellular compartment (Menendez-Pelaez et al., 1993). In the nucleus, melatonin binds to specific proteins (Acuña-Castroviejo et al., 1994) and possibly somehow specifically associates with DNA itself. In this position it can provide what is referred to as on-site protection against the destructive effects of the hydroxyl radical. Indeed, both physiological and pharmacological concentrations of melatonin have been found to be very protective of DNA against the chemical carcinogen safrole (Tan et al., 1994). Safrole is known to damage DNA at least in part because it induces the production of a variety of toxic oxygen radicals. This protective action suggests that melatonin might serve as an effective inhibitor of cancer initiation when the

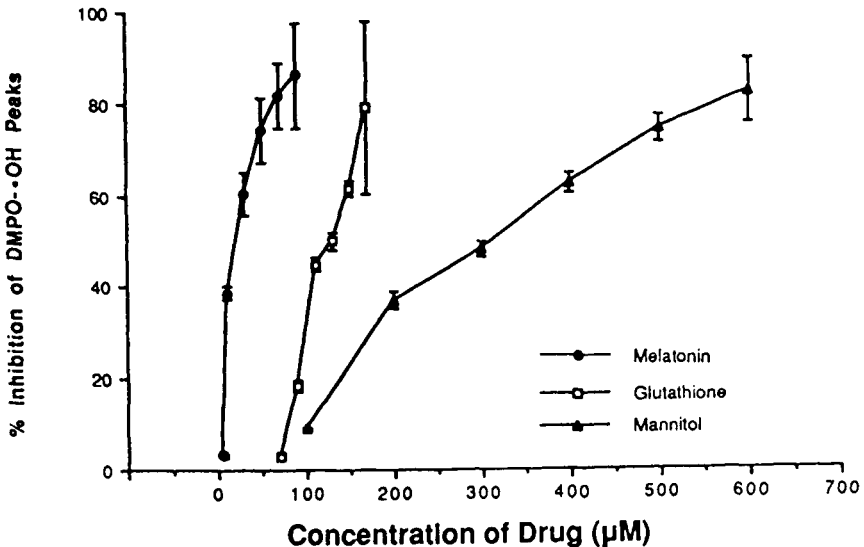

Figure 11. Curves illustrating the ability of melatonin, glutathione, and mannitol to scavenge the highly damaging hydroxyl radical, represented here by DMPO-·OH adducts. The concentrations of melatonin, glutathione, and mannitol required to scavenge 50% (IC₅₀) of the hydroxyl radicals was 21 µM, 123 µM, and 283 µM, respectively. Thus, melatonin was the most effective scavenger in this test. [Redrawn from Tan et al. (1993)].

initiator produces damage of DNA as the result of inducing the production of oxidants.

Besides its potentially suppressive role in cancer initiation, melatonin is also known to retard tumor promotion and progression as well (Blask, 1993). The indole, when given to rats who have developed tumors following treatment with the carcinogen, dimethyl benzanthracene, slows the growth of the tumors and prolongs the survival of the animals (Tamarkin et al., 1981). Likewise, cultured MCF-7 human breast cancer cells are slowed in their growth when melatonin is added to the culture medium (Hill and Blask, 1988). Taken together, the experimental evidence is rather compelling that melatonin may prove to be effective in preventing cancer initiation, as well in slowing the growth of at least some already initiated tumors.

SUMMARY

Slightly over 30 years ago the pineal gland was considered physiologically inconsequential. Even after the discovery of melatonin in the late 1950s (Lerner et al., 1959) and the demonstrations that the metabolic (Axelrod et al., 1965) and endocrine (Hoffman and Reiter, 1965) activities of the gland were influenced by the prevailing light:dark environment, scientists and clinicians were slow to accept the idea of a functional role for the gland and for melatonin in humans. In the intervening years, however, an overwhelming amount of data has been amassed illustrating the remarkable and far-ranging effects of the pineal gland and its hormone melatonin. While there are certain subdisciplines of medicine where the pineal gland is not yet given serious consideration as being functionally relevant, others, i.e., endocrinology, psychiatry, reproductive medicine, and neurological sciences, acknowledge the importance of this multifaceted gland in clinical medicine. It is very likely that further research will reveal the unequivocal importance of melatonin in human physiology and pathophysiology. Considering melatonin acts in every cell, there is very likely not a system that escapes the influence of this important hormone and metabolic regulator.

REFERENCES

- Acuña-Castroviejo, D., Reiter, R.J., Menendez-Pelaez, A. Pablos, M.I., & Burgos, A. (1994). Characterization of high-affinity melatonin binding sites in purified cell nuclei of rat liver. *J. Pineal Res.* 16, 100–112.
- Arendt, J. (1988). Melatonin. *Clin. Endocrinol.* 29, 205–229.
- Arendt, J., Aldhous, M., English, J., Marks, V., & Arendt, J.H. (1987). Some effects of jet lag and their alleviation by melatonin. *Ergonomics* 30, 1379–1384.
- Armstrong, S.M., & Redman, J.P. (1991). Melatonin: a chronobiotic with antiaging properties. *Med. Hypotheses* 34, 300–309.
- Axelrod, J., Wurtman, R.J., & Snyder S.H. (1965). Control of hydroxyindole-O-methyltransferase activity in the rat pineal gland by environment lighting. *J. Biol. Chem.* 249, 1949–1955.

- Bartness, T.J., Powers, J.B., Hastings, M.H., Bittman, E.L., & Goldman, B.D. (1993). The timed infusion paradigm for melatonin delivery: what has it taught us about the melatonin signal, its reception, and the photoperiodic control of seasonal responses? *J. Pineal Res.* 15, 161–190.
- Benitz-King, G., Huerto-Delgado, L., & Anton-Tay, F. (1993). Binding of ^3H -melatonin to calmodulin. *Life Sci.* 53, 201–207.
- Berga, S.L., Mortola, J.F., & Yen, S.S.C. (1988). Amplification of nocturnal melatonin secretion in women with functional hypothalamic amenorrhea. *J. Clin. Endocrinol. Metab.* 68, 242–245.
- Blask, D.E. (1993). Melatonin in oncology. In: *Melatonin* (Yu, H.S., & Reiter, R.J., Eds.), pp. 447–476. CRC Press, Boca Raton, FL.
- Carlson, L.L., Weaver, D.R., & Reppert, S.M. (1989). Melatonin signal transduction in hamster brain: inhibition of adenylyl cyclase by a pertussis toxin-sensitive G-protein. *Endocrinology* 125, 2670–2675.
- Champney, T.H., Joshi, B.N., Vaughan, M.K., & Reiter, R.J. (1985). Superior cervical ganglionectomy results in the loss of pineal concretions in the adult male gerbil, *Meriones unguiculatus*. *Anat. Rec.* 211, 465–468.
- Cozzi, B., Ravault, J.P., Ferrandi, B., & Reiter, R.J. (1988). Melatonin concentration in the cerebral vascular sinuses of sheep and evidence for its episodic release. *J. Pineal Res.* 5, 535–543.
- Dawson, D., & Encel, N. (1993). Melatonin and sleep in humans. *J. Pineal Res.* 15, 1–12.
- Dollins, A.B., Zhdanova, I.V., Wurtman, R.J., Lynch, H.J., & Deng, M.H. (1994). Effect of inducing nocturnal serum melatonin concentrations in daytime on sleep, mood, body temperature, and performance. *Proc. Natl. Acad. Sci. USA* 91, 1825–1828.
- English, J., Arendt, J., Poulton, A., & Symons, A.M. (1987). Short-term variations of circulating melatonin in the ewe. *J. Pineal Res.* 4, 359–366.
- Grad, B.R., & Rosencwaig, R. (1993). The role of melatonin and serotonin in aging: an update. *Psychoneuroendocrinology* 18, 283–295.
- Halliwell, B., & Gutteridge, J.M.C. (1992). Biologically relevant metal iron-dependent hydroxyl radical reactions. *FEBS Lett.* 307, 108–112.
- Harman, D. (1992). Free radical theory of aging. *Mutat. Res.* 275, 257–266.
- Hill, S.M., & Blask, D.E. (1988). Effects of the pineal hormone melatonin on the proliferation and morphological characteristics of human breast cancer cells (MCF-7) in culture. *Cancer Res.* 48, 6121–6125.
- Hoffman, R.A., & Reiter, R.J. (1965). Pineal gland: influence on gonads of male hamsters. *Science* 148, 1609–1611.
- Karasek, M., Pawlikowski, M., Nowakowska-Jankiewicz, B., Kolodziej-Maciejewska, H., Zieleniewski, J., Cieslak, D., & Leidenberger, F. (1990). Circadian variations in plasma melatonin, FSH, LH, and prolactin and testosterone levels in infertile males. *J. Pineal Res.* 9, 149–157.
- Laakso, M.L., Porkka-Heiskanen, T., Alila, A., Sternberg, D., & Johansson, G. (1990). Correlation between salivary and serum melatonin: dependence on serum melatonin levels. *J. Pineal Res.* 9, 39–50.
- Lerner, A.B., Case, J.D., & Heizelman, R.V. (1959). Structure of melatonin. *J. Am. Chem. Soc.* 81, 6084.
- Lewy, A.J., & Newsome, D.A. (1983). Different types of melatonin circadian rhythms in some blind subjects. *J. Clin. Endocrinol. Metab.* 56, 1103–1108.
- Lewy, A.J., & Sack, R.L. (1986). Light therapy and psychiatry. *Proc. Soc. Exp. Biol. Med.* 183, 11–19.
- Lewy, A.J., & Sack, R.L. (1993). The use of melatonin as a marker for circadian phase and as a chronobiotic in blind and sighted humans. In: *Light and Biological Rhythms in Man* (Wetterberg, L., Eds.), pp. 173–188. Pergamon, Oxford.
- Lewy, A.J., Wehr, T.A., Goodwin, R.K., Newsome, D.A., & Markey, S.P. (1980). Light suppresses melatonin secretion in humans. *Science* 310, 1267–1268.
- McIntyre, I.M., Norman, T.R., Burrows, G.D., & Armstrong, S.M. (1987). Melatonin rhythm in human plasma and saliva. *J. Pineal Res.* 4, 177–183.

- McIntyre, I.M., Norman, T.R., Burrows, G.D., & Armstrong, S.M. (1989). Human melatonin suppression by light in intensity dependent. *J. Pineal Res.* 6, 149–156.
- Menendez-Pelaez, A., Poeggeler, B., Reiter, R.J., Barlow-Walden, L.R., Pablos, M.I., & Tan, D.X. (1993). Nuclear localization of melatonin in different mammalian tissues: immunocytochemical and radioimmunoassay evidence. *J. Cell. Biochem.* 53, 373–382.
- Miles, A., Philbrick, D.R.S., & Thompson, C. (Eds.) (1988). *Melatonin: Clinical Perspectives*, p. 288, Oxford University Press, Oxford.
- Monteleone, P., Maj, J., Frisco, M., Kemali, D., & Reiter, R.J. (1992). Depressed nocturnal plasma melatonin levels in drug-free paranoid schizophrenics. *Schizophrenia Res.* 7, 77–84.
- Pangerl, B., Pangerl, A., & Reiter R.J. (1990). Circadian variations of adrenergic receptors in the mammalian pineal gland: a review. *J. Neural Transm.* 81, 17–30.
- Parry, B.L., Berga, S.L., Kripke, D.F., & Gullin, J.C. (1990). Melatonin, light therapy and premenstrual syndrome. In: *Biological Rhythms, Mood Disorders, Light Therapy, and the Pineal Gland* (Shafii, M., & Shafii, S.L., Eds.), pp. 175–189. American Psychiatric Press, Washington, DC.
- Pierpoali, W., & Regelson, W. (1994). Pineal control of aging: effect of melatonin and pineal grafting in aging mice. *Proc. Natl. Acad. Sci. USA* 91, 787–791.
- Poeggeler, B., Reiter, R.J., Tan, D.S., Chen, L.D., & Manchester, L.C. (1993). Melatonin, hydroxyl radical mediated oxidative damage and aging. *J. Pineal Res.* 14, 151–168.
- Puig-Domingo, M., Webb, S.M., Serrano, J., Peinado, M.A., Corcoy, R., Ruscolleda, J., Reiter, R.J., & de Lieva, A. (1992). Melatonin-related hypogonadotrophic hypogonadism. *N. Engl. J. Med.* 357, 1356–1359.
- Reiter, R.J. (1980). The pineal and its hormones in the control of reproduction in mammals. *Endocrine Rev.* 1, 109–131.
- Reiter, R.J. (1981). The mammalian pineal gland: structure and function. *Am. J. Anat.* 162, 287–313.
- Reiter, R.J. (1991). Pineal melatonin: cell biology of its synthesis and of its physiological interactions. *Endocrine Rev.* 12, 151–175.
- Reiter, R.J. (1992). The aging pineal gland and its physiological consequences. *BioEssays* 14, 169–175.
- Reiter, R.J., Tan, D.X., Poeggeler, B., Chen, L.D. & Menendez-Pelaez, A. (1994). Melatonin, free radicals and cancer initiation. In: *Advances in Pineal Research* (Maestroni, G.J.M., Conti, A., & Reiter, R.M., Eds.), Vol. 7, pp. 211–228. John Libbey, London.
- Reiter, R.J., Tan, D.X., Poeggeler, B., Menendez-Pelaez, A., Chen, L.D., & Saarela, S. (1994). Melatonin as a free radical scavenger: implications for aging and age-related diseases. *Ann. N.Y. Acad. Sci.* 719, 1–12.
- Reppert, S.M., Weaver, D.R., Rivkees, E.A., & Stopa, E.G. (1988). Putative melatonin receptors in the human biological clock. *Science* 242, 78–81.
- Rosenthal, N.E., Sack, D.A., Gillin, J.C., Lewy, A.J., Goodwin, F.K., Davenport, Y., Mueller, P.S., Newsome, D.A., & Wehr, T.A. (1984). Seasonal affective disorder. *Arch. Gen. Psychiatry* 41, 72–80.
- Shida, C.S., Castrucci, A.M.L., & Lamy-Freund, M.T. (1994). High melatonin solubility in aqueous medium. *J. Pineal Res.* 16, 198–201.
- Stankov, B., & Reiter, R.J. (1990). Melatonin receptors: current status, facts and hypotheses. *Life Sci.* 46, 971–982.
- Stokkan, K.A., & Reiter, R.J. (1994). Melatonin rhythms in Arctic urban residents. *J. Pineal Res.* 16, 33–36.
- Stokkan, K.A., Reiter, R.J., Nonaka, K.O., Lerchl, A., & Vaughan, M.K. (1991). Food restriction retards aging of the pineal gland. *Brain Res.* 545, 66–72.
- Tamarkin, L., Cohen, M., Roselle, D., Reichert, C., Lippman, M., & Chabner, B. (1981). Melatonin inhibition and pinealectomy enhancement of 7, 12-dimethyl-benz(a)anthracene induced mammary tumors in the rat. *Cancer Res.* 41, 4432–4436.
- Tan, D.X., Chen, L.D., Poeggeler, B., Manchester, L.D., & Reiter, R.J. (1993). Melatonin: a potent, endogenous hydroxyl radical scavenger. *Endocrine J.* 1, 57–60.

- Tan, D.S., Reiter, R.J., Chen, L.D., Poeggeler, B., Manchester, L.D., & Barlow-Walden, L.R. (1994). Both physiological and pharmacological levels of melatonin reduce DNA adduct formation induced by the carcinogen safrole. *Carcinogenesis* 15, 215–218.
- Tortosa, F., Puig-Domingo, M., Peinado, M.A., Oriola, J., Webb, S.M., & de Lieva, A. (1989). Enhanced circadian rhythm of melatonin in anorexia nervosa. *Acta Endocrinol. (Copenhagen)* 120, 574–579.
- Vaughan, G.M., Meyer, G.G., & Reiter, R.J. (1978). Evidence for a pineal-gonad relationship in the human. In: *The Pineal and Reproduction* (Reiter, R.J., Ed.), pp. 191–223. Karger, Basel.
- Vollrath, L. (1981). *The Pineal Organ*, pp. 665. Springer, Berlin.
- Voordouw, B.C.G., Euser, R., Verdonk, R.E.R., Alberda, B.Th., de Jong, F.H., Drogendijk, A.C., Fauser, B.C.J.M., & Cohen, M. (1992). Melatonin and melatonin-progestin combinations alter pituitary-ovarian function in women and can inhibit ovulation. *J. Clin. Endocrinol. Metab.* 74, 108–117.
- Waldhauser, F., & Steger, H. (1986). Changes in melatonin secretion with age and pubescence. In: *Melatonin in Humans* (Wurtman, R.J., & Waldhauser, F., Eds.), pp. 183–197. Springer, Vienna.
- Waldhauser, F., Ehrhart, B., & Förster, E. (1993). Clinical aspects of melatonin action: impact of development, aging and puberty, involvement of melatonin in psychiatric disease and importance of neuroimmunoendocrine interactions. *Experientia* 49, 671–681.
- Wehr, T.A. (1991). The duration of human melatonin secretion and sleep response to changes in daylength (photoperiod). *J. Clin. Endocrinol. Metab.* 83, 1276–1280.
- Wetterberg, L., Beck-Friis, J., & Kjellman, B.F. (1990). Melatonin as a marker of a subgroup of depression in adults. In: *Biological Rhythms, Mood Disorders, Light Therapy, and the Pineal Gland* (Shafii, M., & Shafii, S.L., Eds.), pp. 69–84. American Psychiatric Press, Washington, DC.

RECOMMENDED READINGS

- Armstrong, S.M., & Redman, J. (1991). Melatonin: A chronobiotic with anti-aging properties. *Med. Hypotheses* 34, 300–399.
- Cagnacci, A. (1997). The influences of melatonin on human circadian rhythms. *Chronobiol. Intl.* 14(2), 205–220.
- Poeggeler, B., Reiter, R.J., Tan, D.X., Chen, L.D., & Manchester, L.C. (1994). Melatonin, hydroxyl-radical-mediated oxidative damage, and aging: A hypothesis. *J. Pineal Res.* 14, 151–168.
- Reiter, R.J. (1991). Pineal melatonin: Cell biology of its synthesis and of its physiological interactions. *Endocrine Rev.* 12, 151–180.
- Reiter, R.J., Melchiorri, D., Sewerynek, E., Poeggeler, B., Barlow-Walden, L.R., Chuan, J.J., Ortiz, G.G., & Acuña-Castroviejo, D. (1995). A review of the evidence supporting melatonin's role as an antioxidant. *J. Pineal Res.* 18, 1–11.

Chapter 6

Pituitary–Thyroid Relationships

JAMES A. MAGNER

Introduction	166
Early Studies of TSH	167
The Pituitary–Thyroid Axis	168
Negative Feedback	168
The T ₃ -Receptor	170
Clinical Thyroid Function Testing	171
Total T₄: A Broad Normal Range	175
Diurnal Variation of TSH Release	176
Newborn Screening	177
Inappropriate Secretion of TSH	177
Structure of α-Subunit Gene	179
Structure of TSH β-Subunit Gene	181
Normal β -Gene Structure	181
TSH β -Subunit Mutations	181
Pretranslational Regulation of TSH Subunit Biosynthesis	182
Posttranslational Processing of TSH	184
Summary	187

Principles of Medical Biology, Volume 10A
Molecular and Cellular Endocrinology, pages 165–189.
Copyright © 1997 by JAI Press Inc.
All rights of reproduction in any form reserved.
ISBN: 1-55938-815-3

INTRODUCTION

Thyroid-stimulating hormone (TSH) is a glycoprotein secreted by the pituitary gland that is normally the most important substance that controls thyroid function in mammals. This key hormone has been relatively highly conserved in evolution and also plays an important endocrine role in birds, reptiles, amphibians, and fish. TSH has a molecular weight of 28,000 and is composed of two noncovalently linked subunits, α and β (Pierce and Parsons, 1981). TSH is chemically related to luteinizing hormone (LH) and follicle-stimulating hormone (FSH), as well as to placental chorionic gonadotropin (CG) (Figure 1). TSH is synthesized by thyrotrophs in the anterior pituitary, stored in secretory granules, and released into the bloodstream to bind to and activate thyroid cells.

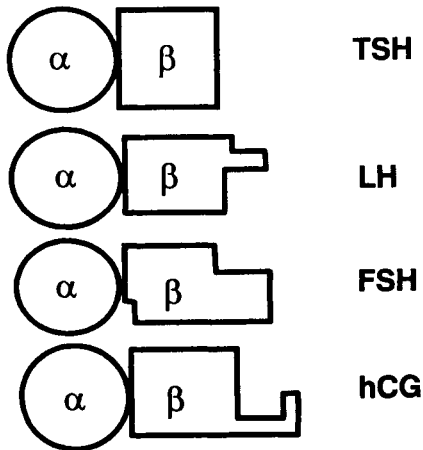

Figure 1. Family of glycoprotein hormones. Three pituitary hormones (TSH, LH, FSH) and one placental hormone (hCG) share a common evolutionary history. Within a species, the α -subunit is identical; different β -subunits provide biologic specificity. The α - and β -subunits are derived from different genes and are noncovalently bound in the heterodimers. Every subunit also has substantial covalently bound carbohydrate from which the term "glycoprotein hormone" is derived. There is a high degree of homology among the β -subunits, which is clinically relevant. Women with very elevated serum hCG levels, for example, as in choriocarcinoma, may exhibit partial proteolytic cleavage of their circulating hCG; the 30-amino acid carboxyterminal extension of the β -subunit may be cleaved leaving a molecule similar to TSH, which may then induce hyperthyroidism.

EARLY STUDIES OF TSH

Autopsies, conducted by Niépce, of patients with congenital hypothyroidism (cretinism) in the mid-nineteenth century incidentally disclosed enlarged pituitary glands, but the significance of this finding was not appreciated (Sawin, 1988). Thirty years later, Rogowitsch performed thyroidectomies on rabbits and noted hyperplasia of the pituitary gland, but he also did not properly understand this phenomenon. Only in the mid-twentieth century was the concept of a pituitary–thyroid feedback loop, sometimes called the pituitary–thyroid axis, well formulated by Hoskins and others.

A young anatomist at Berkeley, Philip E. Smith, wanted to better define the function of the pituitary gland, but he had little money for experiments. In 1912, he performed inexpensive studies using tadpoles. After removing the pituitaries, the thyroid glands atrophied and the tadpoles grew slowly to a large size without going through metamorphosis. Another young biologist, Bennet M. Allen, noted similar results working independently at the University of Kansas. Both workers correctly deduced that the pituitary gland secreted a thyroid-stimulating substance. Smith and Allen met by chance at a meeting of the Western Society of Naturalists in 1916 and excitedly exchanged information; they later independently published their results in the same volume of *Science*. Smith later showed that injection of a bovine pituitary extract preserved the thyroid in hypophysectomized tadpoles, and by 1926 he demonstrated that injection of rat or bovine pituitary partially repaired the thyroid in hypophysectomized rats. Of note, no claim was made for the existence of a specific thyrotrophic substance in the pituitary since it was thought that known compounds, such as growth hormone, might be responsible.

With the advent of the more sensitive guinea pig thyroid gland assay, Loeb, Aron, and others confirmed that a thyrotrophic substance was present in extracts of bovine anterior pituitary. Greep and colleagues in 1935 found that by changing preparatory conditions, the thyrotrophic activity shifted from the LH-containing fractions to the FSH-containing fractions, thereby proving that TSH was a separate pituitary hormone. In 1957, Condliffe and Bates at the National Institutes of Health employed the new methodology of ion exchange chromatography, using diethylaminoethyl cellulose, to generate enriched preparations of TSH. Pierce and colleagues, working independently at UCLA, also used ion exchange chromatography to enrich TSH activity. Both laboratories benefitted by using the better McKenzie bioassay in which TSH caused release of thyroid radioiodine into the bloodstream of mice. Papkoff and Samy recognized in 1967 that ovine LH consisted of two nonidentical subunits (Papkoff and Samy, 1967). By 1971, Pierce and colleagues had defined the α - and β -subunits of TSH and their amino acid sequences and had demonstrated that the β -subunit determined the biological specificity of the heterodimer (Pierce, 1974).

Radioimmunoassays for TSH allowed the basic physiology of TSH in man and several species to be well-described. Detection of elevated serum TSH levels

became a useful clinical tool to diagnose primary hypothyroidism, but suppressed TSH levels in hyperthyroid states could not be distinguished from the low normal levels of TSH. During the 1980s, sensitive immunoradiometric assays (IRMA), many employing monoclonal antibodies, came into widespread use and allowed suppressed and normal TSH levels to be distinguished. The status of TSH in other clinical states such as central hypothyroidism, the syndrome of the inappropriate secretion of TSH, and nonthyroidal illness was better delineated. During the late 1980s, the nucleotide sequence of the TSH receptor, a very low abundance protein that had eluded a generation of researchers, was finally determined (Vassart and Dumont, 1992). It had been known for decades that autoantibody formation to this receptor was the underlying cause of one of the most prevalent thyroid disorders, Graves' disease.

THE PITUITARY-THYROID AXIS

Negative Feedback

The basic negative feedback-type system that normally controls thyroid function is illustrated in Figure 2. Thyroxine (T_4), the predominantly secreted thyroid hormone, has a slow metabolic clearance rate with a half-time of about one week

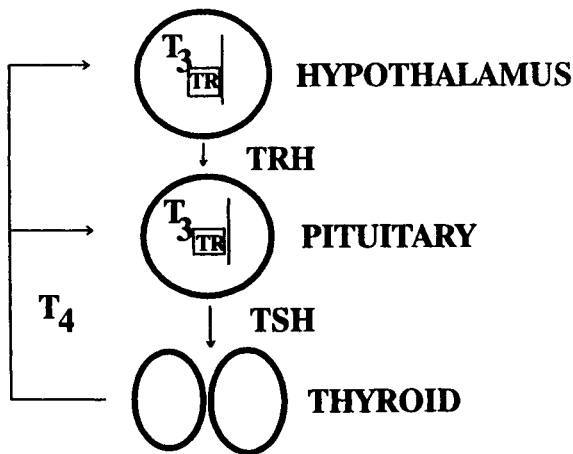

Figure 2. The hypothalamic-pituitary-thyroid axis. The hypothalamus releases thyrotropin-releasing hormone (TRH), which causes secretion of thyroid-stimulating hormone (TSH) by the pituitary. TSH stimulates release of T_4 , which is converted to T_3 in the periphery and centrally. T_3 binds to nuclear thyroid hormone receptors (TR) which bind to DNA and have multiple effects including a reduction of TSH and TRH. When T_4 levels fall in the circulation, T_3 levels fall and more TRH and TSH are released. This is a classical "negative feedback" endocrine system.

in man (Chopra, 1991). Thus, the level of this hormone in the bloodstream varies little from day to day. The level of T_4 is maintained between a lower and upper limit by release of more or less TSH from the anterior pituitary gland. As the blood level of T_4 drifts downward, the inhibitory influence of thyroid hormone on the synthesis and secretion of TSH is diminished. TSH binds to and stimulates thyroid cells until the increase in the circulating T_4 level again suppresses the thyrotrophs in the anterior pituitary.

Measurement of hormone levels has clinical utility. Primary disease of the thyroid gland may cause clinical hypothyroidism and a reduced serum T_4 level along with an elevated TSH level. Of note, TSH increases in a roughly logarithmic fashion as serum T_4 falls. Thus, a mildly hypothyroid female patient with a T_4 only a little lower than her usual T_4 may have an easily recognized increase in the TSH level (Case 1).

Case 1

Primary Hypothyroidism. On a routine evaluation 5 years ago, this 40-year-old woman had normal blood studies, including a T_4 level of 8 $\mu\text{g/dL}$ and TSH of 1.8 $\mu\text{U/mL}$. Because of increasing fatigue during the past 2 months, blood studies were performed and disclosed a T_4 level of 5 $\mu\text{g/dL}$ and an elevated TSH of 22.3 $\mu\text{U/ml}$. A small goiter was present and deep tendon reflexes were mildly delayed. Additional testing showed that anti-peroxidase antibodies and anti-thyroglobulin antibodies were present in serum in large amounts, consistent with a diagnosis of Hashimoto's thyroiditis. Therapy with L-thyroxine 100 μg daily was prescribed. The patient felt completely well and had normal serum T_4 and TSH levels 10 weeks later. This patient had clinical hypothyroidism even though her serum T_4 level of 5 $\mu\text{g/dL}$ was within the broad normal range. TSH is a valuable test for diagnosing primary hypothyroidism.

For Case 1, and the other cases, the normal ranges for laboratory values are:

T_4 , 4.5–11.0 $\mu\text{g/dL}$.

TSH, 0.5–4.0 $\mu\text{U/mL}$.

24-h radioiodine uptake, 8–30%

Prolactin, 0–12 ng/mL.

Cortisol, AM baseline, 5–25 $\mu\text{g/dL}$.

Cortisol, stimulated, >20 $\mu\text{g/dL}$.

Testosterone, male, 350–1000 ng/dL.

About 95% of clinical hypothyroidism in adults is caused by primary hypothyroidism. Rarely a patient may become hypothyroid due to disease in the pituitary or hypothalamus, such as a pituitary tumor. These patients will have clinical symptoms and signs of hypothyroidism, and will have a T_4 level in serum lower than their usual level, but the TSH cannot rise substantially due to the so-called

“central disease.” This is secondary hypothyroidism (Case 2). Pituitary hormones other than TSH also may be deficient in such patients.

Case 2

Central Hypothyroidism. A 50-year-old man complained of fatigue, headaches, and decreased libido for six months. On physical examination, the pulse was 60/min and regular, and temporal visual fields were mildly impaired bilaterally. Blood studies showed T_4 4 $\mu\text{g/dL}$, TSH 2 $\mu\text{U/mL}$, prolactin 1000 ng/mL, baseline cortisol 6 $\mu\text{g/dL}$, cortisol after synthetic ACTH 25 $\mu\text{g/dL}$, and testosterone 100 ng/dL. MRI of the sella revealed a 2-cm pituitary tumor. Therapy with bromocriptine, L-thyroxine and testosterone was begun. Two months later, the patient felt improved; repeat MRI of the sella showed tumor shrinkage, and blood work disclosed: T_4 9 $\mu\text{g/dL}$, TSH 1 $\mu\text{U/mL}$, and prolactin 8 ng/mL.

This patient had central hypothyroidism. If the cortisol level had failed to rise to >20 $\mu\text{g/dL}$ after synthetic ACTH administration, then adrenal insufficiency would have been present, and it would have been crucial to add hydrocortisone (often given as cortisone acetate) to the therapeutic regimen to avoid precipitation of adrenal crisis when thyroid hormone was replaced. Because TSH levels may be unreliable in central hypothyroidism, follow-up of this man's thyroid status will depend on clinical symptoms and serum T_4 level, which should be maintained in the 9 to 11 $\mu\text{g/dL}$ range.

Additional details of the feedback system depicted in Figure 2 deserve comment. T_4 feeds back in a negative fashion not only on the anterior pituitary but also on the hypothalamus. Normally, the hypothalamus intermittently releases the tripeptide thyrotropin-releasing hormone, TRH, but release of TRH is inhibited by T_4 . TRH was the first hypothalamic releasing factor to be discovered, an achievement by Guilleman and Schally for which they were awarded the Nobel Prize in Medicine. Administration of TRH to patients, the TRH-stimulation test, was a clinically useful test before the advent of sensitive TSH assays. After an intravenous bolus of TRH, the blood level of TSH normally peaked at 20 or 30 min. Failure of the TSH to rise briskly by 30 min and then decline was suggestive of hyperthyroidism, or pituitary or hypothalamic disease. In hyperthyroidism, TSH showed no rise after TRH, whereas in central disease, the TSH rise often was delayed and prolonged.

The T_3 -Receptor

As detailed in Figure 2, it is not precisely T_4 that feeds back to suppress TSH but actually triiodothyronine (T_3). In some sense, T_4 may be viewed as a prohormone with the chief function of being converted to the short-lived, active hormone, T_3 , by removal of one iodine atom by the enzyme 5'-deiodinase (Larsen, 1982). The thyroid gland normally secretes very little T_3 directly (a disorder called T_3 -toxicosis results when this general rule is violated). Instead, T_4 circulates in the bloodstream largely bound to proteins (such as thyroxine-binding globulin and albumin), dissociates from proteins to become free- T_4 , and then is converted in peripheral tissues

to active T_3 . A caveat is that the pituitary 5'-deiodinase has somewhat different properties than 5'-deiodinase found in liver or other tissues. Once formed, T_3 binds to a protein in the nucleus of cells known as the T_3 -receptor, which in turn, binds to specific DNA sequences called thyroid response elements (TREs). Transcription of genes having TREs may be increased or decreased by T_3 . Multiple forms of T_3 -receptors have been discovered (Lazar, 1993), and a patient with a mutant receptor may exhibit clinical resistance to thyroid hormone. For example, looking at Figure 2, a mutant T_3 -receptor in the pituitary might allow the feedback system to come to equilibrium at an apparently inappropriate point with an elevated serum T_4 level but a normal serum level of TSH. Because T_3 may bind with less affinity to a mutant receptor, a higher level of T_4 (and of T_3) is required to bring the feedback system into balance.

Clinical Thyroid Function Testing

When too much thyroid hormone is present in the bloodstream, the production and release of TSH by the pituitary is shut down. Because of the logarithmic relationship between serum T_4 and TSH levels, only a minor elevation of serum T_4 is required to suppress TSH levels. Thus, suppression of TSH as measured in a modern TSH assay is now a sensitive means to detect mild hyperthyroidism (Case 3). Although Case 3 highlights a young woman with Graves' disease as an example, it should be noted that there are multiple causes of hyperthyroidism. Thus, when an elevated T_4 and suppressed TSH are discovered in a patient, the specific cause of the hyperthyroidism (toxic multinodular goiter, thyroiditis, Graves' disease, etc.) must still be determined before proper therapy can be given. Only in unusual patients, such as those having TSH-producing pituitary tumors, or with resistance to thyroid hormone, will the serum level of TSH be detectable in the presence of an elevated free T_4 level. These unusual patients have the syndrome of the inappropriate secretion of TSH.

Case 3

Mild Hyperthyroidism. A 20-year-old woman noted fatigue and a small nontender goiter and asked her physician to check a "thyroid hormone level" while she was having a routine exam. Her pulse was 80/min and regular, and her weight had been stable. A serum T_4 level was 10 $\mu\text{g/dL}$, within the "normal range," and the issue was not pursued. One month later, she felt more fatigued, had lost 4 pounds, and her pulse was 88/min. The serum T_4 level was 10.5 $\mu\text{g/dL}$, again within the "normal range," but a TSH level was suppressed below the detectable limit of 0.03 $\mu\text{U/mL}$.

If a TSH level had been measured initially, her hyperthyroid state would have been diagnosed sooner. In ambulatory patients, a suppressed TSH level is often indicative of hyperthyroidism.

A thyroid scan showed diffuse homogeneous uptake of tracer consistent with Graves' disease. Three alternative therapies (antithyroid drugs, thyroid surgery, and

radioiodine) were explained to the patient, and she favored the latter. A radioiodine 24-h uptake measurement was elevated at 50%, and 12 mCi of ^{131}I were administered orally. Propranolol was administered for 4 weeks to eliminate symptoms of hyperthyroidism, and 4 months later she felt entirely well and had serum T_4 7 $\mu\text{g}/\text{dL}$ and TSH 2 $\mu\text{U}/\text{mL}$. One year later, she continued to feel well. T_4 was 6.5 $\mu\text{g}/\text{dL}$, but TSH was 10 $\mu\text{U}/\text{mL}$, so L-thyroxine therapy was begun.

Clinical dilemmas more commonly arise because T_4 is normally largely bound to serum proteins. Conditions that elevate the serum level of thyroxine-binding globulin (TBG), such as use of estrogens, will cause the serum total T_4 to be high, but the normal TSH will rule out hyperthyroidism (Case 4). The serum free T_4 is generally normal in those cases as well. Less commonly, a patient may have a low level of thyroxine-binding globulin resulting in a low total T_4 ; a normal TSH and free T_4 level will obviate inappropriate therapy with thyroid hormone (Case 5).

Case 4

Euthyroid Hyperthyroxinemia. A 20-year-old woman noted fatigue and asked her physician to check a “thyroid hormone level” while she was having a routine exam (compare to Case 3). Her pulse was 80/min and regular, and her weight had been stable. A serum T_4 level was elevated at 13.6 $\mu\text{g}/\text{dL}$, but TSH was normal at 1 $\mu\text{U}/\text{mL}$ and the T_3 resin uptake test was low, suggestive of elevated TBG in the serum. When phoned, the woman recalled that she was taking birth control pills but had forgotten to mention it. The normal TSH confirms a euthyroid state in this patient.

Case 5

Low Serum TBG. A 51-year-old business executive felt entirely well. When he applied for an insurance policy blood tests were performed, and his application was held up because a serum T_4 level was 1.2 $\mu\text{g}/\text{dL}$. There were no symptoms or signs of hypothyroidism. Urinalysis and liver function studies were normal, repeat T_4 level was 1.1 $\mu\text{g}/\text{dL}$, T_3 resin uptake test was high, TSH level was normal, and TBG level was low. This man is euthyroid, likely has congenital TBG deficiency, and merely has a peculiar laboratory result that should not interfere with his insurability. No therapy is indicated.

Because TSH is such a sensitive indicator of thyroid function, it is generally the preferred test when assessing a patient’s thyroid status. Some physicians believe that mild chronic over- or underreplacement of patients treated with thyroid hormone may cause osteopenia or subclinical hypothyroidism, respectively. The TSH level can be a sensitive guide for “fine-tuning” dosage during chronic therapy (Case 6).

Case 6

Fine Adjustment of L-Thyroxine Dose. A 47-year-old woman was found to have primary hypothyroidism 10 years previously and was placed on L-thyroxine 100 µg/day. Presently, she feels entirely well, serum T₄ level is 10 µg/dL, and serum TSH is mildly elevated at 6 µU/mL. The L-thyroxine dose is raised to 112 µg/day. Three months later, she still feels entirely well, the T₄ level is slightly elevated at 11.8 µg/dL, but the TSH is normal at 1.2 µU/mL. Some patients on L-thyroxine therapy have T₄ levels just above the upper limit of normal when the TSH level indicates that they are euthyroid. In patients without pituitary disease, the TSH is a sensitive indicator of thyroid status and may be used to make fine adjustments of the L-thyroxine dose.

The serum TSH level may occasionally be misleading regarding a patient's thyroid status, as when, for example, the thyroid status of a patient is changing. Patients with untreated hyperthyroidism for many months will have chronically suppressed thyrotrophs that may require a few weeks to become active after restoration of euthyroidism (Case 7). This may be particularly vital to appreciate after radioiodine therapy for hyperthyroidism, when the serum total T₄ level may fall to low levels yet the serum TSH level remains low for several weeks. Such patients who have a rapid therapeutic response to radioiodine should be begun on thyroid hormone replacement therapy when the total T₄ level falls to the mid-normal range.

Case 7

Chronic Suppression of Thyrotrophs. A 28-year-old woman had symptoms and signs of hyperthyroidism for 3 years but was afraid to see a physician because a friend told her she would gain weight if she was treated. After several days of intermittent palpitations, she saw a doctor. Sinus tachycardia, a large, symmetrical, nontender goiter, and tremor of the fingers were present. Serum T₄ level was 20 µg/dL, and TSH was <0.03 µU/mL. The 24-h radioiodine uptake was elevated at 60%, and 10 mCi ¹³¹I was given, along with long-acting propranolol daily. Eight weeks later, she felt much improved but was disturbed by a weight gain of 5 pounds. Serum T₄ level was normal at 6 µg/dL, and TSH was <0.03 µU/mL. Caloric reduction was advised, propranolol was stopped, and 50 µg/day L-thyroxine was begun in spite of the suppressed level of TSH. Six weeks later, the serum T₄ level was 6.1 µg/dL and TSH was 18 µU/mL. The L-thyroxine dose was increased to 100 µg/day. Prolonged hyperthyroidism had chronically suppressed her thyrotrophs so that TSH did not rise immediately when she had an unusually rapid therapeutic response to ¹³¹I. If L-thyroxine had not been started at 8 weeks post-¹³¹I, when TSH was still suppressed, the patient might have become very hypothyroid.

Another nonequilibrium situation that may present clinical dilemmas is the euthyroid-sick syndrome, or syndrome of nonthyroidal illness (Case 8). A patient

who has no thyroid disease but who develops a moderately severe illness (such as a stroke, pneumonia, etc.) and who has a poor caloric intake for several days, will develop abnormal thyroid function tests (Wartofsky and Burman, 1982). Generally, the serum T_3 falls quickly in one or two days, the serum T_4 falls more gradually, and in spite of these low thyroid hormone levels, the TSH fails to rise substantially. Although the fall in the T_3 level has been attributed to a decrease in peripheral tissue 5'-deiodinase activity, the mechanism by which the TSH fails to rise in this syndrome remains imperfectly explained.

Case 8

Euthyroid Sick Syndrome. A 72-year-old woman with chronic illness due to diabetes, congestive heart failure, and metastatic breast cancer was admitted to a hospital because she felt "weak and cold." There was no history of thyroid disease. She was a thin, frail woman with a pulse of 68/min, no goiter, some puffiness of the face, pedal edema, and mildly delayed deep tendon reflexes. A serum T_4 level drawn on admission returned 3.1 $\mu\text{g/dL}$, but the TSH level was pending. The admitting physician performed a Cortrosyn™ (synthetic ACTH) stimulation test, prescribed L-thyroxine 50 $\mu\text{g/day}$, and requested an endocrinology consultation. Two days later, the initial laboratory results were available: TSH was 3 $\mu\text{U/mL}$, baseline cortisol was 10 $\mu\text{g/dL}$, and a post-Cortrosyn™ cortisol level was 26 $\mu\text{g/dL}$. The patient is euthyroid (and has normal adrenal function) so the L-thyroxine was discontinued.

After antibiotic therapy for pyuria and optimization of her diabetes therapy, she feels much better and her appetite and activity has improved markedly. Blood work drawn at this time shows a serum T_4 of 5 $\mu\text{g/dL}$ and TSH 14 $\mu\text{U/mL}$. This is presumed to represent a transient TSH rise due to recovery from chronic illness and no thyroid therapy is prescribed. Three weeks later, she remains improved with a serum T_4 of 6 $\mu\text{g/dL}$ and the TSH is 2 $\mu\text{U/mL}$. See text for discussion.

Some endocrinologists theorize that normal T_4 and T_3 levels during a severe illness might cause the body's metabolism to operate wastefully, and that the lowered T_4 and T_3 levels are physiologically protective, resulting in better nitrogen balance and preserved muscle mass until the severe illness has resolved. Only a few animal and human studies have been performed in which thyroid hormone replacement was instituted in non-thyroidal illness; no dramatic benefit was found, but the heterogeneity of the patients studied may have obscured any benefit. The current consensus is to withhold thyroid hormone from these patients unless the serum TSH level rises to greater than 15 $\mu\text{U/mL}$. This rule of thumb is helpful in most cases but fails in any patient with concomitant pituitary or hypothalamic disease who may be unable to increase TSH secretion; such patients may deserve a trial of partial thyroid hormone replacement, such as 50 to 100 μg per day of L-thyroxine. Also, patients who are in an intensive care unit receiving infusions of dopamine may have TSH secretion suppressed by the drug, so TSH values should be measured a few hours after the dopamine infusion is discontinued. High dose corticosteroids and

somatostatin may also suppress TSH levels. Finally, patients with nonthyroidal illness may pass through a confusing stage during recovery and refeeding when for a few days the TSH may rise to 20 or 30 $\mu\text{U}/\text{mL}$. In this stage of illness, the thyrotrophs apparently are reawakening, and their sensitivity to low thyroid hormone levels is returning. Probably no thyroid hormone therapy is indicated unless the TSH elevation persists more than 10 to 14 days.

Another transient disequilibrium syndrome with misleading thyroid function tests occurs in some patients with acute psychiatric illness (Chopra et al., 1990). The serum TSH is inappropriately normal or mildly elevated when serum T_4 is mildly elevated. It is believed that TSH release is driven centrally. After 2 to 3 weeks, repeat thyroid function tests generally have returned to normal.

TOTAL T_4 : A BROAD NORMAL RANGE

The total T_4 level in serum of normal adults encompasses a broad range from about 4.5 to 11 $\mu\text{g}/\text{dL}$. This total T_4 variation of nearly threefold between different persons is in sharp contrast for many other clinical laboratory values, such as serum sodium concentration, which normally ranges between 135 and 145 mEq/L. The broad normal range of total T_4 was obtained empirically by measuring T_4 in many persons; values greater than or less than two standard deviations from the mean of this normal distribution were deemed abnormal (Figure 3).

Although the normal range is broad, this does not mean that total T_4 in a particular person may be 5 $\mu\text{g}/\text{dL}$ on Monday and 11 $\mu\text{g}/\text{dL}$ on Wednesday. Even though the normal range for the population is broad, a particular person generally

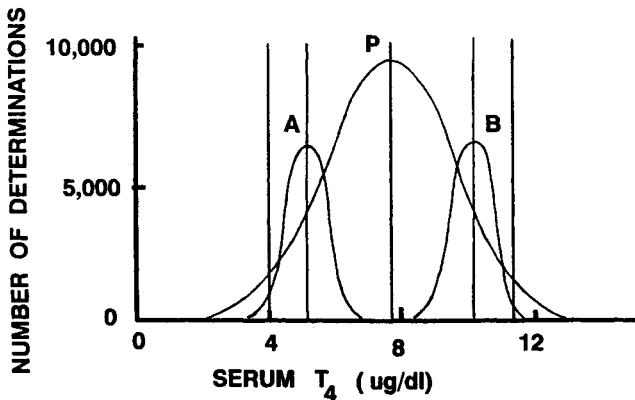

Figure 3. The broad range of serum T_4 . Serum T_4 levels in a large population (P) average a little less than 8 $\mu\text{g}/\text{dL}$ but have a broad range. Multiple measurements of serum T_4 in an individual person (A) fluctuate more narrowly than the range of the whole population. A different individual (B) may have a substantially different mean T_4 level than subject A.

maintains a serum total T_4 level within a much narrower range (Figure 3). A reasonable analogy might be measurement of the height of 10,000 adult men; this population would have a mean height, and the data would fall roughly into a normal distribution. The height of a particular man measured on 10 consecutive days might show a small variation (because the intervertebral discs may be more or less compressed, for example), but the range of variation will be much smaller than that of the whole population.

This broad normal range for total T_4 is the basis of apparent paradoxes that occur clinically with some frequency. A patient who has maintained a total T_4 level in the 5–7 $\mu\text{g/dL}$ range for many years (although a T_4 level has never been measured) may develop symptoms and signs of hyperthyroidism when the total T_4 is 10 $\mu\text{g/dL}$, for example, which is still within the broad range of normal (Case 9). Conversely, a patient who has maintained a total T_4 level in the 8–10 $\mu\text{g/dL}$ range for many years may develop symptoms and signs of hypothyroidism when the total T_4 is 6 $\mu\text{g/dL}$, within the broad normal range. In both instances, although the total T_4 level has not become abnormal for the population, it has become abnormal for that individual. This will be discerned readily by the good clinician when serum TSH levels are ordered. Except in central (pituitary/hypothalamic) disease, disequilibrium states, and a few unusual conditions, the serum TSH is a better guide to a patient's thyroid status than is some measure of serum thyroid hormone levels such as total T_4 or even the free T_4 level.

Case 9

Thyrotoxicosis with A Normal Thyroxine Level. A 71-year-old woman took no medications and felt well but had a small multinodular goiter. Serum T_4 level was 7 $\mu\text{g/dL}$ and TSH level was 2.2 $\mu\text{U/mL}$, both normal. One year later, she noted fatigue and occasional palpitations. Her pulse was 88/min and regular, and blood tests revealed a T_4 of 10 $\mu\text{g/dL}$ and TSH level of <0.03 $\mu\text{U/mL}$. Thyroid scan showed a multinodular goiter, 24-h radioiodine uptake was mildly elevated at 34%, and she was treated with the largest possible outpatient dose of radioiodine, 29.9 mCi. Three months later she felt well.

The natural history of multinodular goiter includes autonomous unremitting hyperfunction of one or more nodules in some patients, who may have symptoms of hyperthyroidism when the serum thyroxine level has not yet exceeded the upper limit of normal. Radioiodine therapy is the preferred therapy since these patients are generally elderly, and late hypothyroidism is uncommon since normal areas of thyroid are hypofunctioning (and relatively protected from radioiodine) when the autonomous nodules are functioning. Follow-up using serum TSH measurement is recommended.

DIURNAL VARIATION OF TSH RELEASE

Like many other hormones, the normal physiological pattern of TSH secretion is characterized by circadian variation (Nicoloff et al., 1970; Vanhaelst et al., 1972).

The serum TSH level rises during the evening, peaks at about midnight, plateaus for several hours, and then declines. Thus, the thyroid gland is exposed to the highest concentrations of TSH at night after this so-called nocturnal surge of TSH. Variation in TSH secretion is believed to be driven by a "clock" in the central nervous system that alters the pattern of release of substances from the hypothalamus, such as TRH, dopamine, and somatostatin. TRH causes thyrotrophs to release TSH, whereas dopamine and somatostatin suppress the release of TSH. Because these and other hypothalamic hormones travel in small vessels directly from the hypothalamus to the pituitary, and then are greatly diluted and destroyed by serum enzymes in the peripheral circulation, the precise mix of stimulatory and inhibitory substances responsible for the circadian variation of TSH remains a mystery. The nocturnal surge of thyrotropin is often deficient in patients with central hypothyroidism but remains intact in persons with primary hypothyroidism (Caron et al., 1986).

NEWBORN SCREENING

Congenital hypothyroidism may result in severe mental retardation because thyroid hormone is required for proper neuronal development during the first few months of life (Porterfield and Hendrich, 1993). Mental retardation is prevented if thyroid deficiency is diagnosed early and thyroid hormone therapy is given. All states in the United States, and many industrialized nations, now have mandatory screening programs for newborn infants. Before discharge from the hospital, each baby has a small drop of blood obtained by heel-stick, and congenital hypothyroidism is sought by measurement of T_4 , TSH, or both. The timing of the blood sample is critical because just after birth, normal infants release a surge of TSH from their pituitaries. Thus, a heel-stick sample obtained on the day of birth would have a physiologically elevated level of TSH present, a confusing result. Infants whose samples are found to have an elevated TSH level by the central laboratory are recalled and resampled by their pediatricians within weeks after birth. Once confirmed, thyroid hormone therapy for hypothyroidism is begun promptly.

INAPPROPRIATE SECRETION OF TSH

Widespread use of sensitive TSH testing is now more frequent for identifying patients who have the paradoxical situation of elevated serum thyroxine levels and detectable TSH levels. Most cases are due to serum T_4 -binding protein abnormalities (such as an elevated serum TBG during estrogen use), or laboratory artifacts, which will be uncovered by measurement of a serum free- T_4 level by equilibrium dialysis. When artifacts have been excluded, a truly elevated free- T_4 level and a truly detectable TSH level confirms the presence of the syndrome of the inappropriate secretion of TSH (Weintraub et al., 1981; Magner, 1993).

This syndrome may occur transiently in patients with acute psychiatric illness, perhaps due to central nervous system stimulation of excessive TRH release; this

generally resolves spontaneously in 2 or 3 weeks. More important causes of the syndrome of the inappropriate secretion of TSH are syndromes of resistance to thyroid hormones and TSH-producing pituitary tumors. Although both are relatively uncommon, it is important to be able to recognize and properly treat such patients.

Resistance to thyroid hormones occurs when a mutation is present in the nuclear T_3 receptor (Refetoff et al., 1967; Usala and Weintraub, 1991; McDermott and Ridgway, 1993). Such mutations generally are inherited in a Mendelian dominant pattern. Determination of free- T_4 and TSH levels in several relatives of the patient may disclose that he is the member of a kindred with resistance to thyroid hormones. Laboratory studies that may prove helpful include measurement of the free α -subunit:TSH molar ratio, and evaluation of the response of TSH after intravenous administration of 500 μg TRH. Patients with thyroid hormone resistance do not have elevated α -subunit production out of proportion to TSH production, and generally have a brisk response to TSH after TRH. On the contrary, patients with TSH-producing pituitary tumors usually have an elevated α -subunit:TSH molar ratio, and fail to double their level of TSH after TRH. A pituitary tumor may cause other signs or symptoms such as headache or visual field problems. TSH-secreting pituitary tumors may secrete growth hormone (causing acromegaly) or prolactin (causing amenorrhea or galactorrhea) in some cases. TSH-producing pituitary tumors are usually readily detectable by CT scan or magnetic resonance imaging of the sella.

The therapy of patients with resistance to thyroid hormones is generally conservative and often consists merely of preventing patients from being incorrectly diagnosed and treated for Graves' disease (Case 10). Some affected children exhibit signs of an attention deficit-hyperactivity disorder (Hauser et al., 1993). Supplemental thyroid hormone may be indicated if growth or development lag. Patients with a more selective resistance of the pituitary may have hyperthyroid symptoms, but standard antithyroid therapies will cause a profound elevation of TSH and a diminished supply of thyroid hormones to some peripheral tissues and are not appropriate long-term. A trial of β -blocking drug, bromocriptine, or 3,5,3'-triiodothyroacetic acid (triac) may be indicated.

Case 10

Inappropriate Secretion of TSH. A 20-year-old woman had vague complaints and a small goiter, and the serum T_4 level was elevated at 19 $\mu\text{g}/\text{dL}$. She denied taking birth control pills and was told she had Graves' disease. She sought a second opinion, and testing showed the T_4 was 19.2 $\mu\text{g}/\text{dL}$ and TSH was 1.3 $\mu\text{U}/\text{mL}$. Repeat testing confirmed the detectable TSH, and the free T_4 was elevated. One of her two brothers, her mother, and her mother's sister also were found to have elevated free T_4 levels and detectable TSH levels. The patient declined having a TRH infusion or imaging of the pituitary, but a presumptive diagnosis of thyroid hormone resistance was made.

No specific therapy was prescribed, but her affected 10-year-old brother, who had short stature and “hyperactivity disorder,” was scheduled for further evaluation.

The therapy of patients with TSH-producing pituitary tumors usually includes surgery to remove or debulk the tumor (Gesundheit et al., 1989; Smallridge, 1993; Losa et al., 1996). Long-term antithyroid therapy is inappropriate and could cause further tumor growth. The somatostatin analogue, octreotide, directly inhibits the release of TSH and may shrink some tumors (Chanson and Warnet, 1992). Octreotide may be used to achieve a euthyroid state prior to pituitary surgery and for maintenance therapy postoperatively if not all of the tumor could be removed.

STRUCTURE OF α -SUBUNIT GENE

The α -subunit gene (Shupnik et al., 1989) has been isolated from several species, including the mouse, rat, cow, and human (Figure 4). The human α -gene is located on chromosome 6. Like α -genes in the other species, the human α -gene has four exons and three introns. It is 9.4 kb in length and contains three introns of 0.4, 1.7, and 6.4 kb.

One transcription start site is present in each of these α -genes. Consensus TATA boxes are located upstream from each start site. A TATA box is centered at -26 base pairs relative to the start of transcription in the human gene and may improve

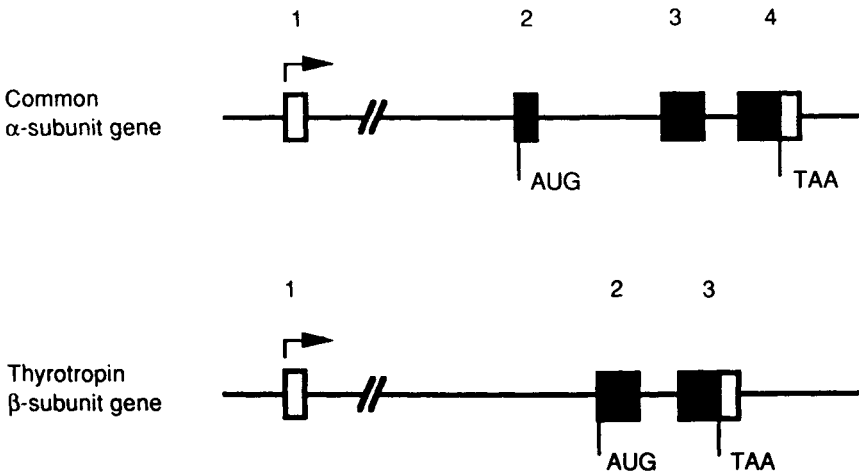

Figure 4. Human TSH-subunit genes. The α - and TSH β -subunit genes have four and three exons (*rectangles*), respectively, separated by introns (*lines*). Black shading denotes coding exons, and open rectangles are untranslated regions. Translational start (AUG) and stop (TAA) codons are shown in their relative positions. Transcriptional start sites are shown by arrows. (From Wondisford et al., 1991).

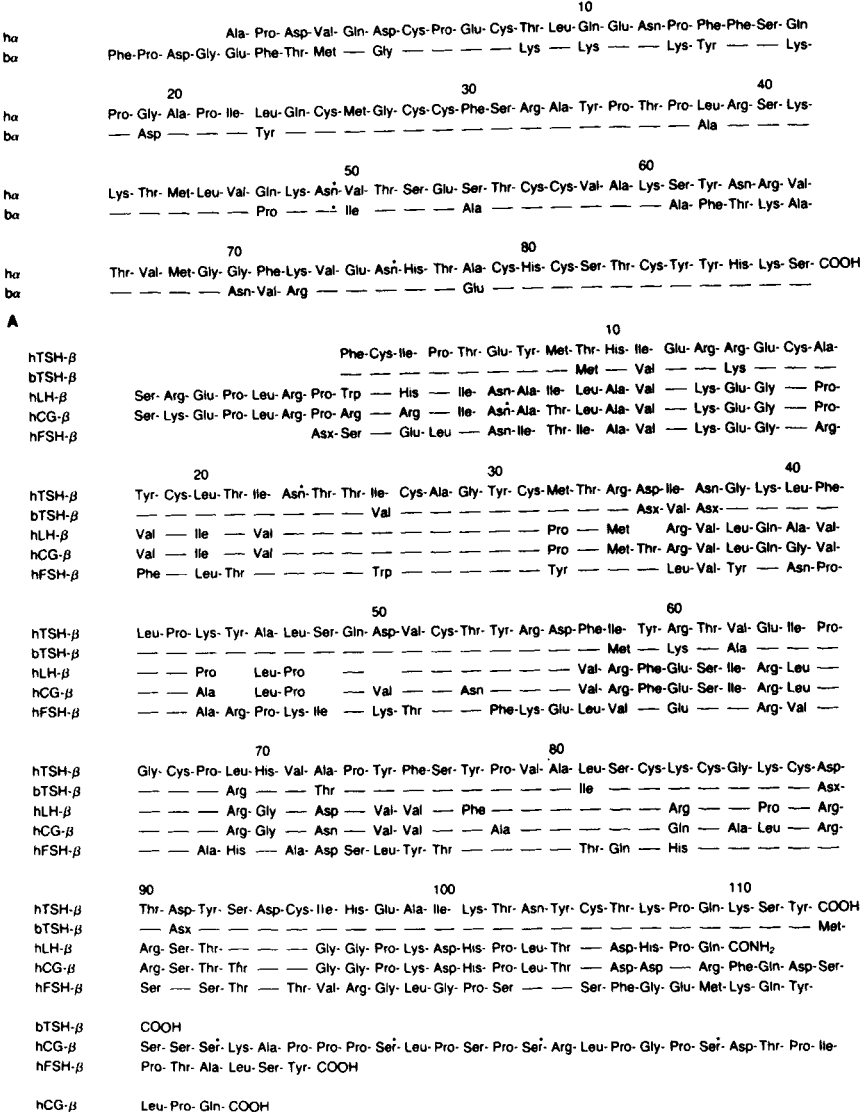

Figure 5. (A) Amino acid sequence of a human α-chain compared with that of the bovine α-chain. Dashes indicate residues identical to those in the human subunit. The sequence shown is that of human CG-α; human TSH-α begins with the valine at position 4. Asterisks indicate the positions of the carbohydrate groups. (B) Amino acid sequence of human TSH-β compared with that of bovine TSH-β and the β-subunits of the other human glycoprotein hormones. Dashes indicate identical residues. Blank spaces are gaps inserted to align for maximum similarity. Asterisks indicate the position of the carbohydrate groups. (From Pierce, 1986).

transcription by RNA polymerase II. The 5' flanking region also contains the palindromic sequence TGACGTCA that confers cAMP responsiveness. The α -subunit protein has 92 amino acids (Figure 5A).

STRUCTURE OF TSH β -SUBUNIT GENE

Normal β -Gene Structure

The TSH β -subunit gene has been isolated from the mouse, rat, and human (Figure 4). The mouse gene contains five exons, but the rat and human genes contain three exons (Wondisford et al., 1991). Both the mouse and rat genes contain two transcriptional start sites, but the human TSH β -gene, located on chromosome 1, has only one start site (Figure 6).

Although the gene sequence predicts a protein of 118 amino acids, human TSH purified from cadaver pituitaries has a β -subunit of 112 amino acids and terminates with a tyrosine residue (Figure 5B). Whether this is an artifactual peptide cleavage during purification or actually represents an unusual physiologic cleavage remains unclear.

TSH β -Subunit Mutations

Recently, a syndrome of familial hypothyroidism due to point mutations in the TSH β -subunit gene has been described (Wondisford et al., 1991). In three Japanese families, the affected persons have a point mutation in exon 2 causing substitution of an arginine residue for glycine. The mutant β -subunit cannot bind to the α -subunit and no functional TSH is detectable in the circulation of these patients.

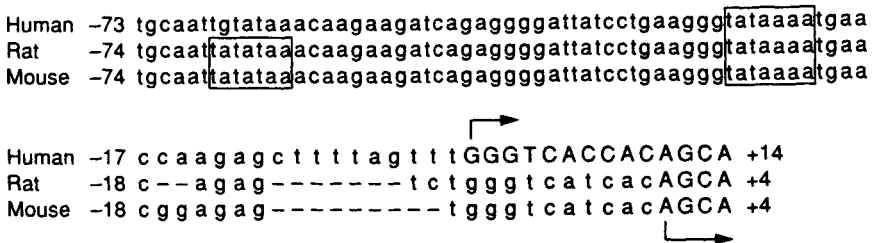

Figure 6. Comparison of the human, rat, and mouse TSH β -subunit 5' flanking and first exon DNA sequences, which are aligned to maximize homology. The 5' flanking region sequences are in lower case letters, and the first exon sequences are in upper case letters. The TATA boxes are indicated, and the transcriptional start sites are denoted by arrows. By convention, the 5' flanking sequences are given negative numbers relative to the start of transcription. (From Wondisford et al., 1991).

A different mutation that alters the 12th amino acid of TSH β -subunit from glutamic acid (GAA) to a stop codon (TAA) has been described in two Greek families. Persons with this autosomal recessive disorder, just like the Japanese patients, produce no functional TSH. Prenatal diagnosis of these disorders in at-risk pregnancies is theoretically possible by using the polymerase chain reaction. Early treatment with thyroid hormone would then be possible.

PRETRANSLATIONAL REGULATION OF TSH SUBUNIT BIOSYNTHESIS

Thyroxine, after conversion to T_3 , inhibits the synthesis of TSH subunits by thyrotrophs (Wondisford et al., 1991). T_3 also inhibits the secretion of thyrotropin-releasing hormone (TRH) by the hypothalamus. In rodent pituitaries and in a mouse thyrotropic tumor model system, thyroid hormone administration causes a rapid and dramatic reduction (50% reduction at 4 h) of the TSH β -subunit mRNA (Shupnik et al., 1989). There is a less rapid and less complete reduction in α -subunit mRNA levels, suggesting that the mechanisms of thyroid hormone inhibition of gene expression (which may involve the proto-oncogenes *c-fos* and *c-jun*) may differ somewhat for the two subunits.

Transcriptional run-on assays showed that T_3 inhibits TSH subunit gene expression principally at the level of gene transcription. T_3 binds to its nuclear receptor which binds to *cis*-acting elements of the TSH α - and β -subunit genes. Such elements have been identified near the transcriptional start sites of these genes. In the human α -subunit gene, thyroid hormone receptor binds to a DNA sequence between -22 and -7 base pairs (Figure 7) whereas the rat and human TSH β -genes have thyroid-hormone response elements located further downstream. The human TSH β -gene has two thyroid hormone receptor binding sites within the DNA sequence between +3 and +37 base pairs, located in the first exon, and binding at both sites is believed necessary for full thyroid hormone inhibition of gene expression (Figure 7).

TRH stimulates thyrotrophs (Figure 8) via a guanyl nucleotide-binding protein that activates phospholipase C, which hydrolyzes phosphatidylinositol-4,5-bisphosphate (PIP_2) to diacylglycerol (DAG) and inositol-1,4,5-triphosphate (IP_3). DAG, in turn, activates protein kinase C, which phosphorylates and activates *trans*-acting nuclear factors that increase TSH-subunit gene expression. *Cis*-acting elements between -128 and +8 base pairs in the human TSH β -subunit gene appear to mediate the TRH effect. A site between -128 and -60 base pairs shares homology to a Pit-1 binding site found in the growth hormone and prolactin genes. Pit-1 is a pituitary-specific transcriptional factor that is present in about half of thyrotrophs; in somatotrophs and lactotrophs Pit-1 appears to be important in the biosynthesis of cell-specific products. In contrast to the human β -subunit gene in the rat, the DNA sequences that mediate TRH responsiveness appear to be further upstream.

Increased cAMP levels stimulate transcription of the α - and β -subunit genes. In the human TSH β -subunit, the region between -128 and -28 base pairs is crucial for this response. Dopamine decreases TSH secretion, an effect that may be mediated by reduced cAMP levels in thyrotrophs. Somatostatin may also mediate its inhibitory effect on TSH secretion via reduced cAMP levels. Vasopressin may stimulate TSH-subunit gene expression by increasing cAMP levels.

POSTTRANSLATIONAL PROCESSING OF TSH

TSH is a glycoprotein. The α -subunit has two asparagine-linked oligosaccharides, and the β -subunit has one (Pierce and Parsons, 1981). Thyrotrophs also secrete excess free α -subunits which have an additional O-glycosylation site.

TSH subunits are cotranslationally glycosylated with oligosaccharides that contain three glucose, nine mannose, and two *N*-acetylglucosamine residues, called high-mannose units (Magner, 1990). This oligosaccharide, abbreviated $\text{Glc}_3\text{Man}_9\text{GlcNAc}_2$, is preassembled in the rough endoplasmic reticulum (RER) linked to a long organic molecule, the dolichol phosphate carrier. There is an *en bloc* transfer of the preassembled oligosaccharide from the dolichol carrier to the appropriate asparagine residue in the nascent peptide as the protein is winding off the ribosome and entering the lumen of the RER. An asparagine present in the sequences, asparagine-X-serine or asparagine-X-threonine (where X is any amino acid), may be subject to N-glycosylation with such a high-mannose oligosaccharide. Noncovalent association of TSH α - and β -subunits begins in the RER while the subunits still bear high-mannose oligosaccharides (Magner and Weintraub, 1982). Glucose and mannose residues are progressively trimmed, followed by the addition of GlcNAc and other sugars by specific glycosyltransferases to form complex oligosaccharides (Figure 9).

Although partially processed oligosaccharides may be present on some secreted TSH molecules, many sugar chains are thought to bear sialic acid or sulfated oligosaccharides (Magner, 1990). The precise structure of the three sugar chains on each TSH molecule is believed to influence some of the biological properties of the hormone. When terminal galactose residues are masked by sialic acid residues, for example, the metabolic clearance rate of the hormone is affected such that it circulates longer in the bloodstream. The complex oligosaccharides also may alter the intrinsic bioactivity of a TSH molecule.

Thus, one cannot speak of "the structure of TSH." Unlike a pancreatic islet cell that always secretes qualitatively the same insulin, although quantitatively different amounts of insulin from time to time, a pituitary thyrotroph may vary the structure of TSH secreted as well as the amount (Figure 10). Whether this is of physiologic significance in normal persons, or whether this is merely an epiphenomenon, remains under active investigation.

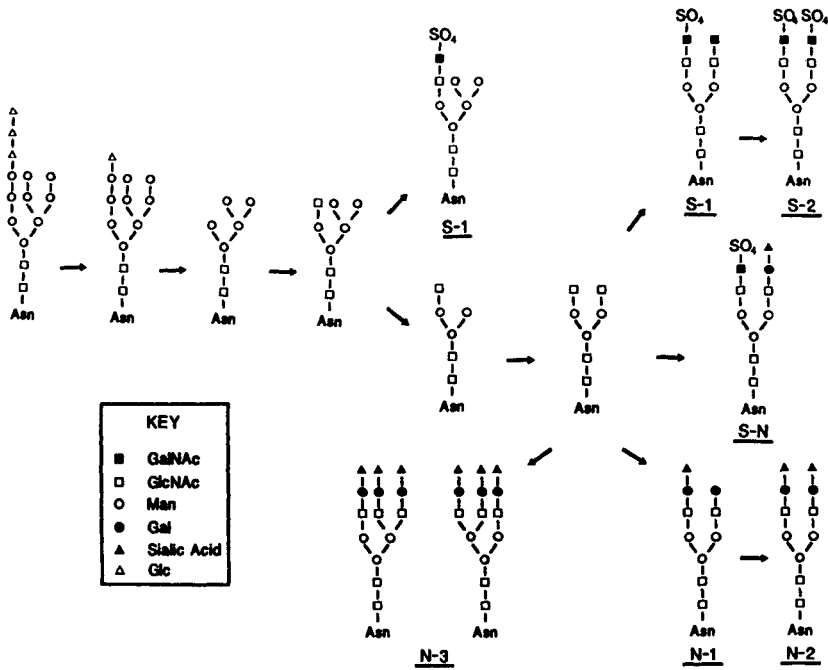

Figure 9. Pathway for biosynthesis of sulfated and sialylated asparagine-linked oligosaccharides. S-1, 2, 3 and N-1, 2, 3 refer to the number of sulfate or sialic acid residues present. See text for discussion. (From Wondisford et al., 1991 and Magner et al., 1992).

Analyses of TSH from pituitaries and from serum of humans and animals reveals that the heterogeneity of the oligosaccharides causes multiple isoforms of TSH to exist (Magner, 1990). These isoforms can be separated by their differences in charge using isoelectric focusing, for example; they also may be separated by employing lectins, proteins that bind particular sugars with some specificity. Such analyses have revealed that patients and animals with primary hypothyroidism not only have more TSH present in the circulation, they also have an enrichment in circulating isoforms of TSH having sialic acid residues. Patients with hypothalamic disease who may lack TRH or other factors, and who develop central hypothyroidism, often do not have an undetectable TSH as might be predicted but instead may have a mildly elevated TSH that appears to have reduced bioactivity (Faglia et al., 1989). Patients with the euthyroid sick syndrome also may have altered TSH isoforms (Lee et al., 1987; Magner et al., 1997). Patients with TSH-secreting pituitary tumors secrete heterogeneous forms of TSH (Magner et al., 1992).

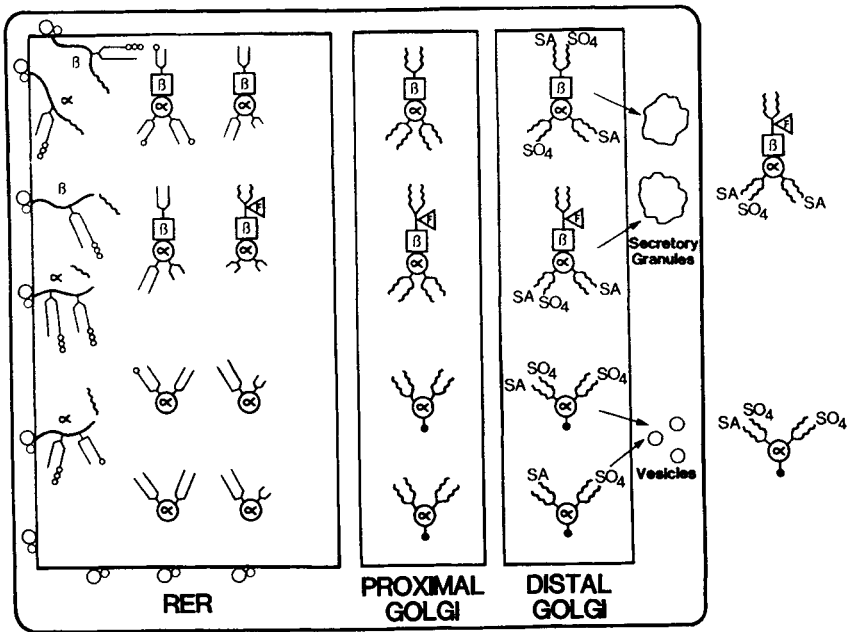

Figure 10. Model of TSH biosynthesis. The rough endoplasmic reticulum (RER), proximal Golgi, distal Golgi, secretory granules, secretory vesicles, and secreted products of a thyrotroph cell are depicted. The cell secretes intact TSH and excess free α -subunits. Circles and squares represent α - and β -subunits of TSH, respectively. In the RER, there is cotranslational cleavage of signal peptides (wavy lines) and glycosylation of asparagine residues. The α -subunit receives two high mannose carbohydrate units, while the β -subunit receives one. The oligosaccharides added *en bloc* contain three glucose residues (small circles), which are trimmed. Excess α -subunits are present in the RER, and combination of α - and β -subunits begins in the RER while subunits still contain high mannose oligosaccharides. Mannose residues are trimmed. A few enzymes normally present in Golgi may be active at unusually early sites of the secretory pathway when thyrotrophs are active. Fucose (F in triangle) addition occurs in both RER and Golgi. Sugar chains are processed to complex oligosaccharides (zig-zag lines) containing galactose, N-acetylgalactosamine, sulfate (SO₄), and sialic acid (SA) residues. Excess α -subunits are O-glycosylated (solid circles). TSH heterodimers enter a regulated pathway of secretory granules, whereas excess α -subunits enter a more constitutive pathway of secretory vesicles. Finally, fully processed TSH and α -subunits that contain heterogeneous oligosaccharide structures are secreted. (From Wondisford et al., 1991).

SUMMARY

Normal thyroid function is vital for proper brain development and good health. The major positive regulator of thyroid hormone secretion normally is the anterior pituitary hormone TSH. Thyroxine (T_4) inhibits the release of TSH from the pituitary [by the interaction of triiodothyronine (T_3) with nuclear thyroid hormone receptors], establishing a classical negative feedback endocrine system. TSH is a glycoprotein hormone related to LH, FSH, and hCG. Measurement of serum T_4 and TSH values has great clinical utility. A suppressed serum TSH value generally indicates a state of hyperthyroidism, while an elevated TSH value suggests primary hypothyroidism. There are many caveats in the interpretation of clinical thyroid function tests, however. Because T_4 is largely bound to serum proteins, such as thyroxine-binding globulin (TBG), common conditions that elevate TBG levels (such as pregnancy or estrogen use), will elevate serum T_4 levels. A euthyroid state may be confirmed by a normal serum TSH value, as well as a normal free T_4 level. The oligosaccharides of TSH undergo extensive posttranslational processing during biosynthesis and affect important biological properties of TSH, such as its rate of metabolic clearance. TSH in hypothyroid animals and patients is more highly sialylated than TSH in euthyroid subjects. Current investigations hope to determine whether or not TSH oligosaccharide heterogeneity is physiologically regulated.

REFERENCES

- Caron, P.J., Nieman, L.K., Rose, S.R., & Nisula, B.C. (1986). Deficient nocturnal surge of thyrotropin in central hypothyroidism. *J. Clin. Endocrinol. Metab.* 62, 960–964.
- Chanson, P., & Warnet, A. (1992). Treatment of thyroid-stimulating hormone-secreting adenomas with octreotide. *Metabolism* 41, 62–65.
- Chopra, I.J., Solomon, D.H., & Huang, T.-S. (1990). Serum thyrotropin in hospitalized psychiatric patients: evidence for hyperthyrotropinemia as measured by an ultrasensitive thyrotropin assay. *Metabolism* 39, 538–543.
- Chopra, I.J. (1991). Nature, sources, and relative biologic significance of circulating thyroid hormones. In: *The Thyroid* (Braverman, L.E. & Utiger, R.D., Eds.), pp. 126–143. J.B. Lippincott, Philadelphia.
- Faglia, G., Bitensky, L., Pinchera, A., Ferrari, C., Paracchi, A., Beck-Peccoz, P., Ambrosi, B., & Spada, A. (1979). Thyrotropin secretion in patients with central hypothyroidism: evidence for reduced biological activity of immunoreactive thyrotropin. *J. Clin. Endocrinol. Metab.* 48, 989–998.
- Gesundheit, N., Petrick, P.A., Nissim, M., Dahlberg, P.A., Doppman, J.L., Emerson, C.H., Braverman, L.E., Oldfield, E.H., & Weintraub, B.D. (1989). Thyrotropin-secreting pituitary adenomas: clinical and biochemical heterogeneity. *Ann. Int. Med.* 111, 827–835.
- Hauser, P., Zametkin, A.J., Martinez, P., Vitiello, B., Matochik, J.A., Mixson, A.J., & Weintraub, B.D. (1993). Attention deficit-hyperactivity disorder in people with generalized resistance to thyroid hormone. *N. Engl. J. Med.* 328, 997–1001.
- Larsen, P.R. (1982). Thyroid-pituitary interaction. Feedback regulation of thyrotropin secretion by thyroid hormones. *N. Engl. J. Med.* 306, 23–32.
- Lazar, M.A. (1993). Thyroid hormone receptors: multiple forms, multiple possibilities. *Endocr. Rev.* 14, 184–193.

- Lee, H.-Y., Suhl, J., Pekary, A.E., & Hershman, J.M. (1987). Secretion of thyrotropin with reduced concanavalin-A-binding in patients with severe nonthyroid illness. *J. Clin. Endocrinol. Metab.* 65, 942–945.
- Losa, M., Giovanelli, M., Persani, L., Mortini, P., Faglia, G., & Beck-Peccoz, P. (1996). Criteria of cure and follow-up of central hyperthyroidism due to thyrotropin-secreting pituitary adenomas. *J. Clin. Endocrinol. Metab.* 81, 3084–3090.
- Magner, J.A., & Weintraub, B.D. (1982). Thyroid-stimulating hormone (TSH) subunit processing and combination in microsomal subfractions of mouse pituitary tumor. *J. Biol. Chem.* 257, 6709–6715.
- Magner, J.A. (1990). Thyroid-stimulating hormone: biosynthesis, cell biology, and bioactivity. *Endocr. Rev.* 11, 354–385.
- Magner, J.A., Klibanski, A., Fein, H., Smallridge, R., Blackard, W., Young, Jr., W., Ferriss, J.B., Murphy, D., Kane, J., & Rubin, D. (1992). Ricin and lentil lectin-affinity chromatography reveals oligosaccharide heterogeneity of thyrotropin secreted by 12 human pituitary tumors. *Metabolism* 41, 1009–1015.
- Magner, J.A. (1993). TSH-mediated hyperthyroidism. *The Endocrinologist* 3, 289–296.
- Magner, J., Roy, P., Fainter, L., Barnard, V., & Fletcher, Jr., P. (1997). Transiently decreased sialylation of thyrotropin (TSH) in a patient with the euthyroid sick syndrome. *Thyroid*, 7, 55–61.
- McDermott, M.T., & Ridgway, E.C. (1993). Thyroid hormone resistance syndromes. *Am. J. Med.* 94, 424–432.
- Nicoloff, J.T., Fisher, D.A., & Appleman, Jr., M.D. (1970). The role of glucocorticoids in the regulation of thyroid function in man. *J. Clin. Invest.* 49, 1922–1929.
- Papkoﬀ, H., & Samy, T.S.A. (1967). Isolation and partial characterization of the polypeptide chains of bovine interstitial cell-stimulating hormone. *Biochim. Biophys. Acta* 147, 175–177.
- Pierce, J.G. (1974). Chemistry of thyroid-stimulating hormone. In: *Handbook of Physiology* (Field, J., Ed.), Vol. 4, Part 2, Section 7, pp. 79–101. American Physiological Society, Bethesda, MD.
- Pierce, J.G., & Parsons, T.F. (1981). Glycoprotein hormones: structure and function. *Ann. Rev. Biochem.* 50, 465–495.
- Pierce, J.G. (1986). Thyrotropin: Chemistry. In: *The Thyroid* (Ingbar, S. and Braverman, L., Eds.), 5th ed., J.B. Lippincott, Philadelphia.
- Porterfield, S.P., & Hendrich, C.E. (1993). The role of thyroid hormones in prenatal and neonatal neurological development—current perspectives. *Endocr. Rev.* 14, 94–106.
- Refetoff, S., DeWind, L.T., & DeGroot, L.J. (1967). Familial syndrome combining deaf-mutism, stippled epiphyses, goiter, and abnormally high PBI: possible target organ refractoriness to thyroid hormone. *J. Clin. Endocrinol. Metab.* 27, 279–294.
- Sawin, C.T. (1988). Defining thyroid hormone: its nature and control. In: *Endocrinology, People and Ideas* (McCann, S.M., Ed.), pp. 149–199. American Physiological Society, Bethesda, MD.
- Shupnik, M.A., Ridgway, E.C., & Chin, W.W. (1989). Molecular biology of thyrotropin. *Endocr. Rev.* 10, 459–475.
- Smallridge, R.C. (1993). Thyrotropin-secreting tumors. In: *Endocrine Tumors* (Mazzaferrri, E.L., Ed.). Blackwell Scientific Publications, Oxford.
- Usala, S.J. (1991). Molecular diagnosis and characterization of thyroid hormone resistance syndromes. *Thyroid* 1, 361–367.
- Vanhaelst, L., Van Cauter, E., Degaute, J.P., & Golstein, J. (1972). Circadian variations in serum thyrotropin levels in man. *J. Clin. Endocrinol. Metab.* 35, 479–482.
- Vassart, G., & Dumont, J.E. (1992). The thyrotropin receptor and the regulation of thyrocyte function and growth. *Endocr. Rev.* 13, 596–611.
- Wartofsky, L., & Burman, K. (1982). Alterations in thyroid function in patients with systematic illnesses: the “euthyroid sick syndrome.” *Endocr. Rev.* 3, 164–217.

- Weintraub, B.D., Gershengorn, M.C., Kourides, I.A., & Fein, H. (1981). Inappropriate secretion of thyroid-stimulating hormone. *Ann. Int. Med.* 95, 339–351.
- Wondisford, F.E., Magner, J.A., & Weintraub, B.D. (1991). Chemistry and biosynthesis of thyrotropin. In: *The Thyroid* (Braverman, L.E., & Utiger, R.D., Eds.), pp. 257–276. J.B. Lippincott, Philadelphia.

This Page Intentionally Left Blank

Chapter 7

The Parathyroid Gland: REGULATION OF PRODUCTION OF PARATHYROID HORMONE

HITOSHI MIKI, JONATHAN A. VAN HEERDEN, and
LORRAINE A. FITZPATRICK

Introduction	192
Regulation of PTH Gene Expression	193
Effect of $[Ca^{2+}]_e$ on PTH Gene Transcription	193
Effects of $1,25(OH)_2D_3$ and Other Steroid Hormones on PTH Gene Transcription	194
Regulation of Degradation of Synthesized PTH	194
Intracellular Regulation of PTH Secretion	195
First Messengers for PTH Secretion	195
Second Messengers for PTH Secretion	197
Regulation of Cell Proliferation	202
Summary	203

Principles of Medical Biology, Volume 10A
Molecular and Cellular Endocrinology, pages 191–205.
Copyright © 1997 by JAI Press Inc.
All rights of reproduction in any form reserved.
ISBN: 1-55938-815-3

INTRODUCTION

Extracellular ionized calcium plays a critical role in numerous functions for the mammalian species, and carefully controlled regulation and maintenance of Ca^{2+} homeostasis is essential for life functions. The concentration of extracellular ionized calcium, ($[\text{Ca}^{2+}]_e$), is controlled within a narrow range of 1.0 to 1.3 mM in mammals by the cooperative actions of parathyroid hormone (PTH), calcitonin, and $1,25(\text{OH})_2\text{D}_3$. Among these calciotropic hormones, PTH is the primary hormone and the production of PTH, in turn, is tightly regulated by $[\text{Ca}^{2+}]_e$. PTH is an 84-amino acid protein with a molecular mass of approximately 9600 daltons. A small incremental decrease of $[\text{Ca}^{2+}]_e$ stimulates rapid secretion of PTH and allows PTH action on the target organs of kidney and bone. PTH increases reabsorption of Ca^{2+} in the distal tubules of the kidney and stimulates production of 1,25-dihydroxyvitamin D ($1,25(\text{OH})_2\text{D}_3$) from 25-hydroxyvitamin D ($25(\text{OH})\text{D}$) in the proximal tubules. Dihydroxyvitamin D promotes intestinal absorption of Ca^{2+} and release of Ca^{2+} from bone. PTH also acts directly to mobilize Ca^{2+} from bone. Therefore, the elevated level of PTH stimulated by hypocalcemia results in the increase of $[\text{Ca}^{2+}]_e$ toward the normal concentration. With an increase of $[\text{Ca}^{2+}]_e$, namely hypercalcemia, the opposite series of changes occurs.

There are four regulated levels in the pathway of PTH production (Figure 1). The first level is the transcriptional level beginning with the gene encoding PTH to mRNA in nucleus. Extracellular calcium, $1,25(\text{OH})_2\text{D}_3$, and some steroid hormones

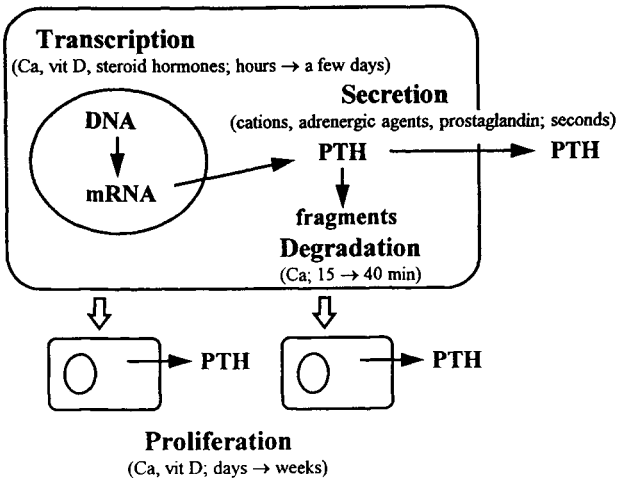

Figure 1. Regulation of PTH secretion. The production of PTH is regulated at several distinct levels (regulatory agents; stimulus duration before change in PTH production) vitamin D; $1,25(\text{OH})_2\text{D}_3$.

control biosynthesis of PTH at this level and can require from a few hours to a few days to effect changes in synthesis. After synthesis, PTH is packaged in secretory vesicles for exocytosis, or degraded proteolytically from an active form to inactive fragments within the cell. The change of secretory rate of PTH occurs within seconds to respond to circulating levels of cations and other agents. Up to 90% of newly produced PTH can undergo degradation within 15 to 40 min in response to hypercalcemia. When hypocalcemia or low circulating levels of $1,25(\text{OH})_2\text{D}_3$ continue for days to weeks, the proliferative rate of parathyroid cells increases and the rise in cell number results in greater augmentation of PTH production.

REGULATION OF PTH GENE EXPRESSION

The genes encoding human, bovine, rat, pig, and chicken PTH have been cloned. The location of the human PTH gene is on the short arm of chromosome 11 at band 11p15 and this gene contains three exons and two introns. Mature PTH mRNA produced by splicing is translated into an 115-amino acid protein, preproPTH. Then, in the endoplasmic reticulum, preproPTH is cleaved to proPTH (90 amino acids) and transported to the Golgi apparatus. There, the final product of the PTH gene, mature intact PTH (84 amino acids), is synthesized by removal of the pro signal sequence.

Effect of $[\text{Ca}^{2+}]_e$ on PTH Gene Transcription

The extracellular calcium level is the principal factor regulating PTH gene transcription. The effects of $[\text{Ca}^{2+}]_e$ on PTH synthesis *in vitro* were first studied by Russell et al. (1983). High $[\text{Ca}^{2+}]_e$ (2.5 mM) decreased PTH mRNA levels in primary cultures of bovine parathyroid cells after 16 h. Further incubation for 72 h with high $[\text{Ca}^{2+}]_e$ induced an even more remarkable decrease of PTH mRNA levels. Using cultured parathyroid cells, Brookman and colleagues confirmed that 3.0 mM extracellular Ca^{2+} lowered steady-state levels of PTH mRNA and low $[\text{Ca}^{2+}]_e$ (0.4 mM) increased PTH gene transcription slightly (Brookman et al., 1986). In human parathyroid adenoma cells, the inhibitory effects of $[\text{Ca}^{2+}]_e$ on PTH synthesis also occur. High $[\text{Ca}^{2+}]_e$ reduced levels of human PTH mRNA by 50% (Farrow et al., 1988). The mechanism through which high extracellular calcium inhibits PTH gene expression was proposed by Okazaki et al. (1992) to occur through a negative calcium responsive element (nCaRE). The responsive element nCaRE was identified in an upstream region of the PTH gene. *In vivo*, although inhibitory effects of high $[\text{Ca}^{2+}]_e$ on PTH gene expression were reported to be none or modest, hypocalcemia in intact animals markedly stimulates PTH gene transcription suggesting that transcriptional activity is suppressed in physiological states.

Effects of 1,25(OH)₂D₃ and Other Steroid Hormones on PTH Gene Transcription

The parathyroid gland is one of the target organs for 1,25(OH)₂D₃ and high-affinity receptors for 1,25(OH)₂D₃ are present in nuclei of parathyroid cells. Like [Ca²⁺]_e, 1,25(OH)₂D₃ is also an important regulator of PTH gene transcription. Silver and colleagues and Cantley and coworkers exposed bovine parathyroid cells to high concentrations of 1,25(OH)₂D₃ for more than 48 h and found decreased levels of PTH mRNA (Cantley et al., 1985; Silver et al., 1985). This inhibitory effect of 1,25(OH)₂D₃ on gene transcription is similar to that of Ca²⁺ and has been confirmed by additional studies both *in vitro* and *in vivo*. The inhibition is thought to be mediated by the action of 1,25(OH)₂D₃ on the 5'-flanking region of the PTH gene.

Hormones that stimulate adenylyl cyclase may promote PTH gene expression since the PTH gene has a consensus cyclic adenosine monophosphate (cAMP) response element. Glucocorticoids and estradiol increase PTH mRNA in studies using dispersed parathyroid cells and ovariectomized rats, respectively. One hypothesis is that alterations of PTH gene expression by estradiol may be responsible, in part, for the pathogenesis of postmenopausal osteoporosis.

REGULATION OF DEGRADATION OF SYNTHESIZED PTH

Parathyroid cells secrete not only intact PTH but also biologically inactive carboxyl-terminal fragments of PTH (C-PTH) which are degraded from intact PTH within cells. Secretion of C-PTH by parathyroid cells is greatly altered by concentrations of extracellular calcium both *in vitro* and *in vivo*. Alterations in the rate of degradation of intact PTH occur relatively rapidly in response to changes of [Ca²⁺]_e. Hypercalcemia stimulates intracellular degradation of PTH resulting in the secretion of a large amount of C-PTH as compared with intact PTH. On the contrary, under the conditions of hypocalcemia, most of the secreted PTH consists of intact hormone. Thus, the ability to regulate degradation of PTH is very important in determining the level of circulating biologically active PTH in response to hypercalcemia or hypocalcemia.

The calcium-activated neutral proteases, calpains, have been suggested to be involved in the mechanism of intracellular degradation of PTH because these enzymes are Ca²⁺-dependent and interact with protein kinase C (PKC) (Watson et al., 1991). Elevated levels of extracellular Ca²⁺ stimulate phospholipid hydrolysis and increase the production of diacylglycerol (DAG), which may activate calpains, and in turn, activated calpains mediate the degradation of PTH. While this idea is intriguing, further studies will be necessary to reveal the exact role of calpains in the degradation of PTH.

INTRACELLULAR REGULATION OF PTH SECRETION

Calcium homeostasis in response to rapid changes of $[Ca^{2+}]_e$ is maintained primarily by alterations of the rate of PTH exocytosis within seconds.

First Messengers for PTH Secretion

Parathyroid cells are very different from other endocrine cells in that high concentrations of extracellular Ca^{2+} inhibit PTH secretion rather than stimulate secretion. Since the first report in 1942 of this inverse relationship between PTH secretion and $[Ca^{2+}]_e$ in the dog, numerous attempts have been made to investigate the regulation of PTH secretion. The main physiological regulator of PTH secretion is the concentration of extracellular calcium, although many secretagogues have been studied *in vitro*. Mayer and Hurst (1978) studied the relationship between the secretory rate for PTH and serum calcium levels during catheterization of the inferior thyroid veins of calves, and showed a sigmoidal relationship between PTH and serum calcium and a nonsuppressible basal component of PTH secretion even at very high $[Ca^{2+}]_e$.

Brown (1983) investigated this sigmoidal relationship in detail and proposed four parameters that described the regulation of PTH secretion by $[Ca^{2+}]_e$ (Figure 2). The maximal secretory rate represents the acute secretory reserve of the gland when

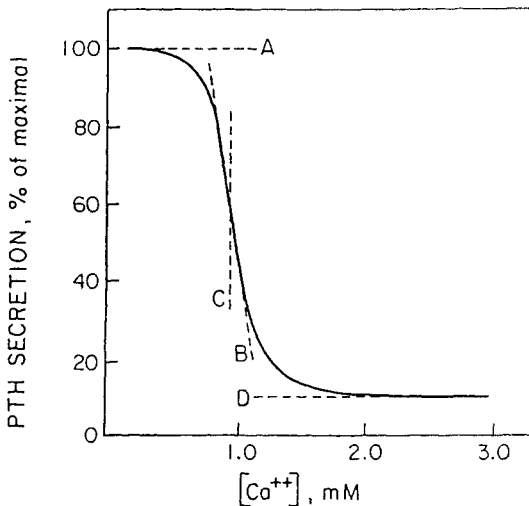

Figure 2. A four-parameter model of the relationship between the concentration of extracellular Ca^{2+} and PTH secretion. (A) Maximal secretory rate; (B) slope at the midpoint of the curve; (C) set point (the concentration of calcium producing half-maximal inhibition of PTH secretion); (D) minimal secretory rate. [Reproduced with permission from Brown, E.M. (1983)].

the parathyroid is stimulated maximally, and this rate may be modulated by alterations of levels of PTH mRNA in cells or by cell number. The slope of the sigmoid curve illustrates the sensitivity of parathyroid cells to the changes of $[Ca^{2+}]_e$ and the "steep" slope represents the characteristics of parathyroid cells which can alter the secretion rate for PTH dramatically in response to small changes in $[Ca^{2+}]_e$. Set point, which is the calcium concentration producing half of the maximal inhibition of secretion, plays a pivotal role in the determination of $[Ca^{2+}]_e$ maintained *in vivo*. In both human and bovine parathyroid cells, "normal" set point is ~ 1.0 mM although variability in different systems has been noted (Fitzpatrick and Leong, 1990). In contrast to normal cells, abnormal parathyroid cells have an elevated set point. The fourth parameter is minimal secretory rate, representing the Ca^{2+} -independent, nonsuppressible component of PTH secretion, and this rate may be dominated by cell number.

The regulation of PTH secretion at not only the glandular level but also at the cellular level has distinctive features. We have studied the effect of extracellular calcium on PTH secretion by individual parathyroid cells using the reverse hemolytic plaque assay, which utilizes complement-mediated cell lysis to detect PTH secretion (Sun et al., 1993) (Figure 3). Plaque area, which represents the amount of PTH secreted from individual cells, has been inversely related to $[Ca^{2+}]_e$. A unique feature of the secretory response in individual cells is the heterogeneity

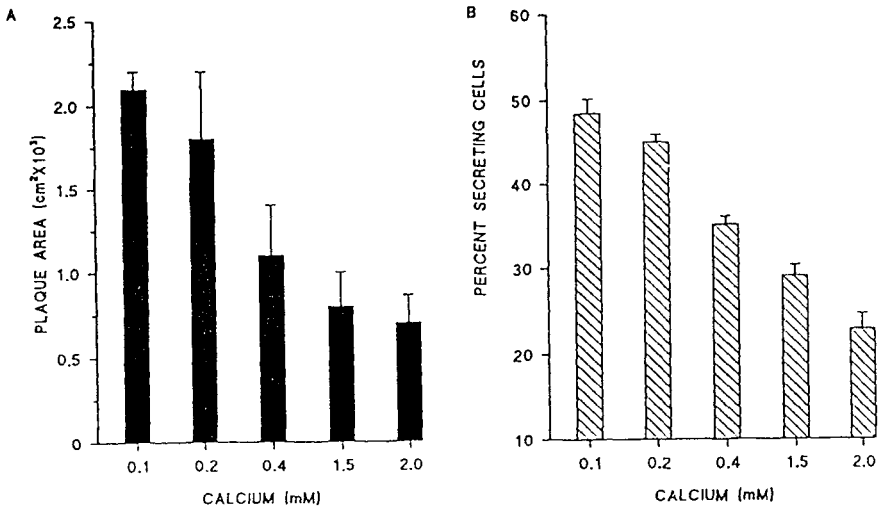

Figure 3. Effect of extracellular calcium on PTH secretion by individual parathyroid cells. Bovine parathyroid cells were dispersed and plated for the reverse hemolytic plaque assay. (A) Plaque area, which is proportional to the amount of PTH secretion. (B) The percentage of cells forming plaques was determined as compared to the total number of cells. Data represent mean \pm S.E.M.

of the secretory response. In response to high concentrations of extracellular calcium, only 23% of cells secrete PTH. Even at low levels of extracellular calcium (0.1 mM) where maximum stimulation is predicted to occur, only approximately 50% of cells respond to the stimulus. This heterogeneity may provide the secretory reserve of the parathyroid cells with the ability to respond to a second or third sequential stimulus. Moreover, the heterogeneity suggests that parathyroid cells may exist in an “on” or “off” secretory state, and this suggestion was supported by morphological studies showing that parathyroid cells pass through cycles of activity and inactivity.

Other first messengers to evoke PTH secretion include dopamine, β adrenergic agonists, and divalent and trivalent cations. Currently, the physiological relevance of these agents remains uncertain although many of these compounds have proven useful in improving our understanding of parathyroid physiology.

Second Messengers for PTH Secretion

PTH secretion is negatively regulated by extracellular calcium. In recent years, the intracellular mechanism(s) through which extracellular calcium modulates PTH secretion has been investigated. There are several candidates for influential second messengers, which transduce the secretion signal to changes in secretion rate of PTH. These candidate messengers include cyclic 3-,5-adenosine monophosphate, guanine nucleotide regulatory proteins, protein kinase C, inositol phosphates, and intracellular calcium (Figure 4).

Cyclic 3',5'-Adenosine Monophosphate

cAMP plays an important role as a second messenger in the mechanism of secretion in many endocrine cells. The relationship of intracellular cAMP content

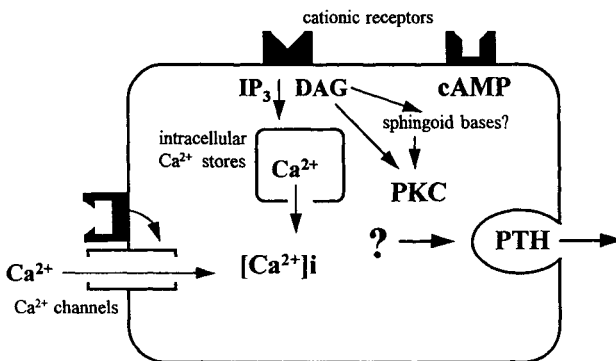

Figure 4. Regulation of PTH secretion. Several second messengers are responsible for the regulation of PTH secretion, PKC, protein kinase C; IP₃, inositol trisphosphate; DAG, diacylglycerol.

and PTH secretion in parathyroid cells has been studied by several investigators. Elevated extracellular levels of divalent cations which inhibit PTH secretion, such as calcium and magnesium, also lower intracellular cAMP content. Addition of agonists that stimulate cAMP production was reported to be followed by rapid increases in PTH secretion (2 min), and there is a close log-linear relationship between intracellular cAMP content and the rate of PTH secretion, regardless of the nature of the agonist (Brown et al., 1978). From these results, it has been suggested that cAMP mediates secretion of PTH. Cyclic AMP may regulate PTH secretion independent of other messengers, such as intracellular calcium and inositol phosphates, because elevation in cellular cAMP content is not accompanied by changes in intracellular levels of either of these agents.

Since it is believed that cAMP exerts its biological actions through activation of cAMP-dependent protein kinases (PKA), Brown and Thatcher (1982) studied the effects of divalent cations and agents elevating cellular cAMP on PTH secretion, cellular cAMP content, and activity of PKA in dispersed parathyroid cells. They reported that isoproterenol, dopamine, and a phosphodiesterase inhibitor caused parallel, dose-dependent increases in PTH secretion and in PKA activity. On the other hand, high concentrations of calcium and magnesium had no effect on PKA activity, in spite of causing substantial inhibition of PTH secretion. Although agents altering intracellular cAMP content such as isoproterenol and dopamine affect the rate of PTH secretion by alterations of cAMP levels, cAMP does not seem to be the key link in mediating the physiological inhibition of PTH secretion by extracellular calcium ions.

Guanine Nucleotide Regulatory Proteins (G-Proteins)

G-proteins link receptors or sensors on cell surfaces to intracellular effector systems in a diversity of cell types. The interaction between G-proteins and the regulation of PTH secretion has been reported. Calcium inhibition of PTH secretion was blocked in cells treated with pertussis toxin, which catalyzes ADP ribosylation and inactivation of the inhibitory adenylyl cyclase coupling an inhibitory G-protein (Fitzpatrick et al., 1986). Moreover, Fitzpatrick et al. (1986) studied the mechanism through which cAMP acts on secretion of PTH and reported that pertussis toxin produced an enhanced response in cAMP production and in PTH secretion in the presence of epinephrine. In contrast, the effects of $\text{PGF}_{2\alpha}$ and α_2 -adrenergic agonists which lower agonist-stimulated cAMP accumulation was reversed by preincubation with pertussis toxin. Brown et al. (1991) confirmed that the inhibitory effect of neomycin, which inhibits PTH secretion, on dopamine-stimulated cAMP accumulation was blocked by preincubating the cells with pertussis toxin. Therefore, in the parathyroid cell, G-proteins mediate the actions of some agents which alter cellular cAMP contents and the rate of PTH secretion.

Protein Kinase C

PKC plays a critical role in numerous cell functions including secretion. Measurement of parathyroid PKC by the translocation assay has shown that this enzyme is active at low $[Ca^{2+}]_e$ and inactive at high $[Ca^{2+}]_e$, suggesting that PKC is involved in secretion of PTH. Clarke et al. (1993) investigated the effect of PKC activators and inhibitors on PTH secretion using the reverse hemolytic plaque assay *in vitro* and reported that PKC activators stimulated PTH secretion at high $[Ca^{2+}]_e$, but not at low $[Ca^{2+}]_e$. They speculated that PKC activation did not further augment PTH secretion at low $[Ca^{2+}]_e$ because PKC is already maximally activated. PKC inhibitors decreased PTH secretion at low $[Ca^{2+}]_e$ and there was no inhibition of PTH secretion at high $[Ca^{2+}]_e$. Similar results were published earlier by Watson et al. (1992). Racke and Nemeth (1993) reported that PKC activators depress PTH secretion at lower concentrations of extracellular calcium and potentiated secretion at the higher $[Ca^{2+}]_e$ and they proposed that the inhibitory and stimulatory effects of PKC activators on PTH secretion may result from PKC affecting different intracellular mechanisms. Shoback and Chen (1990) suggested the possibility that pharmacological activation of PKC desensitizes signaling pathways other than polyphosphoinositide turnover that seems to participate in high Ca^{2+} -induced suppression of PTH secretion, because the ability of PKC activators to stimulate PTH secretion at high Ca^{2+} concentrations is not reversed by raising $[Ca^{2+}]_e$ with ionomycin. Although the exact effects of PKC activators remain unknown, it seems reasonable to propose that PKC plays an important regulatory role in the secretion of PTH. Moreover, Clarke et al. (1993) found PKC stimulation increased steady-state PTH mRNA levels, suggesting PKC may be also involved in the production of PTH at the transcriptional level.

Increases in the concentration of extracellular divalent cations elicit increases in the formation of inositol 1,4,5-trisphosphate (IP_3) and diacylglycerol by means of phosphatidylinositol-4,5-bisphosphate hydrolysis within plasma membranes. Actually, high $[Ca^{2+}]_e$ promotes 1.5- to 3-fold increases in DAG levels within 10 s, which persist for 30 min, in parathyroid cells. These increased DAG levels are usually accompanied by increased PKC activity. Therefore, high $[Ca^{2+}]_e$ must increase PKC activity. Available data, however, suggest just the opposite in parathyroid cells. The activity of PKC was reported to be decreased at high $[Ca^{2+}]_e$ and increased at low $[Ca^{2+}]_e$ in intact parathyroid cells. Concerning this discrepancy, Clarke et al. suggested that DAG stimulated by high $[Ca^{2+}]_e$ can also activate cell membrane sphingomyelinase that catalyzes formation of free sphingoid bases and these sphingoid bases produced inhibited PKC activation. Physiological balance between DAG-induced PKC activation and DAG-induced sphingomyelinase activation may determine the net PKC activity. In this model, PKC activation predominates at low $[Ca^{2+}]_e$ and sphingomyelinase activation predominates at high $[Ca^{2+}]_e$. Further studies are necessary to prove or disprove this hypothesis.

Intracellular Calcium

The concentration of intracellular calcium, $[Ca^{2+}]_i$, has been recognized as a significant second messenger mediating many cellular functions including exocytosis. For example, an increase in $[Ca^{2+}]_i$ is very important for secretagogue-induced insulin release in pancreatic islet cells. Although the close sigmoid relationship between the changes in the secretion rate and alterations of $[Ca^{2+}]_i$ in response to $[Ca^{2+}]_e$ has been reported in parathyroid cells, this relationship encompasses unique responses in parathyroid cells compared with most other endocrine cells. First, parathyroid cells respond to small changes in $[Ca^{2+}]_e$ with large changes in $[Ca^{2+}]_i$. Most cells, however, maintain almost constant levels of $[Ca^{2+}]_i$ in spite of large changes in $[Ca^{2+}]_e$. The other extraordinary feature is that increased $[Ca^{2+}]_i$ inhibits, rather than stimulates, the secretion of PTH in parathyroid cells.

The development of calcium-sensitive indicator probes has facilitated the measurement of $[Ca^{2+}]_i$ in dispersed cells. It is now clear that high $[Ca^{2+}]_e$ elicits a rapid and transient rise in $[Ca^{2+}]_i$, referred as a "spike," followed by a lower sustained increase in $[Ca^{2+}]_i$ in fura-2-loaded parathyroid cells (Nemeth and Scarpa, 1986) (Figure 5). The other cations such as Mg^{2+} and polycationic antibiotics such as

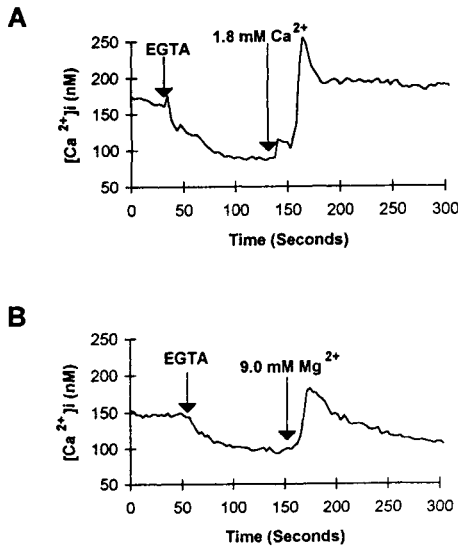

Figure 5. Effect of 1.8 mM extracellular Ca^{2+} and 9.0 mM extracellular Mg^{2+} . Fura-2-loaded bovine parathyroid cells in medium containing 1.8 mM Ca^{2+} were incubated with 0.5 mM EGTA in Ca^{2+} -free, Mg^{2+} -free medium to remove extracellular Ca^{2+} . (A) Addition of 1.8 mM Ca^{2+} evoked a spike followed by a sustained increase in $[Ca^{2+}]_i$. (B) Addition of 9.0 mM Mg^{2+} resulted in a spike in spite of removal of extracellular Ca^{2+} , but an increase in steady-state $[Ca^{2+}]_i$ was absent.

neomycin evoke the spike in spite of removal of extracellular calcium, but increases in steady-state $[Ca^{2+}]_i$ are absent. High extracellular concentrations of Ca^{2+} and Mg^{2+} were reported to produce rapid increases in cellular IP_3 content in parathyroid cells and these increases in IP_3 are related to the spike in $[Ca^{2+}]_i$, because the time course for these alterations is similar and IP_3 can release calcium from intracellular nonmitochondrial stores. Since receptor activation on the plasma membrane often evokes a rapid and transient increase in $[Ca^{2+}]_i$ in a number of secretory cells responding to extracellular stimuli, the existence of a Ca^{2+} receptor has been proposed in parathyroid cells. More recently, Brown et al. (1993) identified a parathyroid cell cation sensing receptor cDNA which encodes a 120-kD polypeptide containing a large extracellular domain and seven membrane-spanning regions, characteristic of the superfamily of G-protein-coupled cell surface receptors. The binding of cations to this receptor increases IP_3 content followed by the release of Ca^{2+} from intracellular stores. It is this release of Ca^{2+} that appears as the spike of $[Ca^{2+}]_i$.

Neomycin and divalent cations other than Ca^{2+} do not cause increases of steady-state $[Ca^{2+}]_i$ in parathyroid cells in spite of their ability to create an initial spike of intracellular calcium. Moreover, La^{3+} , which blocks Ca^{2+} influx through Ca^{2+} channels, decreased $[Ca^{2+}]_i$ in parathyroid cells (Miki et al., submitted). From these results, the increases of steady-state $[Ca^{2+}]_i$ caused by high $[Ca^{2+}]_e$ appear to result from influx of extracellular Ca^{2+} through Ca^{2+} channels. Thus, the increase in $[Ca^{2+}]_e$ elicits two mechanically different changes in $[Ca^{2+}]_i$. Which mechanism contributes to inhibition of PTH secretion caused by high $[Ca^{2+}]_e$?

Since divalent cations other than Ca^{2+} cause release from intracellular calcium stores without increases in steady-state $[Ca^{2+}]_i$ and inhibit PTH secretion, the spike of $[Ca^{2+}]_i$ may be an important signal for the inhibition of PTH secretion. There are, however, several findings conflicting with this idea. Even if the spike of $[Ca^{2+}]_i$ is blocked by buffering with quin-2, secretion of PTH is still inhibited by other cations (Nemeth and Scarpa, 1986). Moreover, we found using digital imaging microscopy and the reverse hemolytic plaque assay, that the parathyroid cells which responded with a spike in $[Ca^{2+}]_i$ secreted more PTH than cells without a spike in the presence of high extracellular Mg^{2+} (Miki et al., 1995). These findings suggest that the mechanism mediated by IP_3 may be independent of the secretion of PTH.

In dispersed bovine cells, the calcium-channel agonist (-)202-791 mimics the action of calcium and strikingly inhibits secretion (Fitzpatrick et al., 1986). On the other hand, the calcium-channel antagonist (+)202-791 stimulates the secretion of PTH. Treatment of the parathyroid cells with pertussis toxin blocked the inhibition of PTH secretion caused by calcium-channel agonist, suggesting a pertussis-sensitive G-protein mediates the activation of calcium channels in the parathyroid cells. Antibodies to the α -subunit of dihydropyridine-sensitive calcium channels and maitotoxin were reported to function as channel agonists and inhibited PTH secretion (Fitzpatrick et al., 1989). Moreover, spontaneous oscillations of

$[Ca^{2+}]_i$ due to influx of extracellular Ca^{2+} through channels were found and these oscillations are related to the inhibition of PTH secretion (Miki et al., 1995). These studies indicate that influx of extracellular calcium through calcium channels is related to the secretion of PTH. We found that high concentrations of extracellular Mg^{2+} inhibited both influx of extracellular calcium through channels and PTH secretion (Miki et al., 1997). Although there is a discrepancy in that inhibition of influx of extracellular calcium rather than stimulation results in inhibition of PTH secretion, both Mg^{2+} and channel agonists are agents which can act on channels and inhibit secretion, suggesting a link between calcium channels and PTH secretion. The increase in $[Ca^{2+}]_i$ may not be necessary to inhibit PTH secretion. Changes in $[Ca^{2+}]_i$, however, seem to be a marker of the action of calcium channels altered by extracellular cations.

While it is possible that 1,3,4,5-tetrakisphosphate, a product of the phosphorylation of IP_3 , is a mediator of influx of extracellular Ca^{2+} , IP_4 may not have the significant effect on influx of extracellular calcium in parathyroid cells. Hawkins et al. (1989) reported that sustained increases of steady-state $[Ca^{2+}]_i$ resulting from influx of Ca^{2+} through calcium channels preceded measurable changes in IP_4 . Moreover, there was no relationship between the mechanism through which extracellular magnesium caused the release of Ca^{2+} from internal stores and another mechanism, which through extracellular Mg^{2+} inhibited Ca^{2+} influx (Miki et al., 1997). Therefore, we suggest that changes of $[Ca^{2+}]_i$ may not alter the rate of PTH secretion and the binding of cations to receptors or to receptors coupled to calcium channels in some manner activate other distinct pathways leading to inhibition of PTH secretion.

REGULATION OF CELL PROLIFERATION

An important regulatory mechanism of PTH production in response to chronic extracellular stimuli lasting more than a few days is cellular proliferation, because increases in cell number can raise the circulating level of PTH without a change, overall, in secretion rate per cell. Although some studies reported there was no effect of $[Ca^{2+}]_e$ on proliferation, many data have supported the notion that hypocalcemia is a significant stimulator of proliferation of parathyroid cells. Low extracellular calcium was reported to increase radioactive thymidine uptake in cells derived from the parathyroid gland. Brandi and coworkers found that proliferation of cells obtained from parathyroid glands was maximal at 0.3 mM $[Ca^{2+}]_e$, and higher $[Ca^{2+}]_e$, up to 2.0 mM, inhibited growth. $1,25(OH)_2D_3$ is also a potent regulator of proliferation. Szabo and colleagues reported that $1,25(OH)_2D_3$ inhibited cell proliferation in rats with experimental uremia due to subtotal nephrectomy.

In vivo, it may be difficult to distinguish the effects of extracellular calcium and $1,25(OH)_2D_3$ individually because these two factors influence proliferation cooperatively. For example, low $[Ca^{2+}]_e$ and low levels of $1,25(OH)_2D_3$ due to renal

failure increase cell number in parathyroid glands remarkably and this morbidity induces secondary hyperparathyroidism.

SUMMARY

Parathyroid hormone secreted from the parathyroid gland plays a significant role in maintaining Ca^{2+} homeostasis. There are four levels of regulation in the production of PTH: transcription, secretion, intracellular degradation, and cellular proliferation, all of which determine the circulating level of PTH. The regulation of secretion and degradation is important to maintain homeostasis in response to the rapid change of $[\text{Ca}^{2+}]_e$. Extracellular concentrations of calcium in the physiologic range regulate PTH production at all levels. Bodily adaptations in response to chronic changes in calcium levels occur at the level of transcription and cellular proliferation. Although there are several candidates for second messengers mediating the change of $[\text{Ca}^{2+}]_e$ at secretion level, no one candidate has been clearly identified to solely mediate inhibition of PTH secretion, and several pathways may act in concert.

ACKNOWLEDGMENTS

We wish to thank Ms. Theresa Strei for her careful reading of the manuscript, and Ms. Nicole Henry for her excellent secretarial assistance. Supported in part by US PHS Grant DK-42572 and DK-42802.

REFERENCES

- Brookman, J.J., Farrow, S.M., Nicholson, L., O'Riordan, J.L., & Hendy, G.N. (1986). Regulation by calcium of parathyroid hormone mRNA in cultured parathyroid tissue. *J. Bone Miner. Res.* 1, 529–537.
- Brown, E.M., Gardner, D.G., Windeck, R.A., & Aurbach, G.D. (1978). Relationship of intracellular 3',5'-adenosine monophosphate accumulation to parathyroid hormone release from dispersed bovine parathyroid cells. *Endocrinology* 103, 2323–2333.
- Brown, E.M., & Thatcher, J.G. (1982). Adenosine 3',5'-monophosphate-dependent protein kinase (cAMP) and the regulation of parathyroid hormone release by divalent cations and agents elevating cellular cAMP in dispersed bovine parathyroid cells. *Endocrinology* 110, 1374–1380.
- Brown, E.M. (1983). Four-parameter model of the sigmoidal relationship between parathyroid hormone release and extracellular calcium concentration in normal and abnormal parathyroid tissue. *J. Clin. Endocrinol. Metab.* 56, 572–581.
- Brown, E.M., Butters, R., Katz, C., & Kifor, O. (1991). Neomycin mimics the effects of high extracellular calcium concentrations on parathyroid function in dispersed bovine parathyroid cells. *Endocrinology* 128, 3047–3054.
- Brown, E.M., Gamba, G., Riccardi, D., Lombardi, M., Butters, R., Kifor, O., Sun, A., Hediger, M.A., Lytton, J., & Hebert, S.C. (1993). Cloning and characterization of an extracellular Ca^{2+} -sensing receptor from bovine parathyroid. *Nature* 366, 575–580.

- Cantley, L.K., Russell, J., Lettieri, D., & Sherwood, L.M. (1985). 1,25-Dihydroxyvitamin D₃ suppresses parathyroid hormone secretion from bovine parathyroid cells in tissue culture. *Endocrinology* 117, 2114–2119.
- Clarke, B.L., Hassager, C., & Fitzpatrick, L.A. (1993). Regulation of parathyroid hormone release by protein kinase-C is dependent on extracellular calcium in bovine parathyroid cells. *Endocrinology* 132, 1168–1175.
- Farrow, S.M., Darmali, R., Gleed, J.H., Hendy, G.H., & O’Riordan, J.L.H. (1988). Regulation of preproparathyroid hormone messenger RNA and hormone synthesis in human parathyroid adenomata. *J. Endocrinol.* 117, 133–138.
- Fitzpatrick, L.A., Brandi, M.L., & Aurbach, G.D. (1986). Prostaglandin F_{2α} and α-adrenergic agonists regulate parathyroid cell function via the inhibitory guanine nucleotide regulatory protein. *Endocrinology* 118, 2115–2119.
- Fitzpatrick, L.A., Brandi, M.L., & Aurbach, G.D. (1986). Calcium-controlled secretion is effected through a guanine nucleotide regulatory protein in parathyroid cells. *Endocrinology* 119, 2700–2703.
- Fitzpatrick, L.A., Brandi, M.L., & Aurbach, G.D. (1986). Control of PTH secretion is mediated through calcium channel and is blocked by pertussis toxin treatment of parathyroid cells. *Biochem. Biophys. Res. Commun.* 138, 960–965.
- Fitzpatrick, L.A., Yasumoto, T., & Aurbach, G.D. (1989). Inhibition of parathyroid hormone release by maitotoxin, a calcium channel activator. *Endocrinology* 124, 97–103.
- Fitzpatrick, L.A., & Leong, D.A. (1990). Individual parathyroid cells are more sensitive to calcium than a parathyroid cell population. *Endocrinology* 126, 1720–1727.
- Hawkins, D., Enyedi, P., & Brown, E. (1989). The effects of high extracellular Ca²⁺ and Mg²⁺ concentrations on the levels of inositol 1,3,4,5-tetrakisphosphate in bovine parathyroid cells. *Endocrinology* 124, 838–844.
- Nemeth, E.F., & Scarpa, A. (1986). Cytosolic Ca²⁺ and the regulation of secretion in parathyroid cells. *FEBS Lett.* 203, 15–19.
- Mayer, G.P., & Hurst, J.G. (1978). Sigmoidal relationship between parathyroid hormone secretion rate and plasma concentrations in calves. *Endocrinology* 102, 1036–1042.
- Miki, M., Maercklein, P.B., & Fitzpatrick, L.A. (1995). Spontaneous oscillations of intracellular calcium and parathyroid secretion in single bovine parathyroid cells. *Endocrinology* 136, 2954–2959.
- Miki, M., Maercklein, P.B., & Fitzpatrick, L.A. (1997). Effect of magnesium on parathyroid cells: Evidence for two sensing receptors or two intracellular pathways. *Am. J. Physiol.* 272, E1–E6.
- Okazaki, T., Ando, K., Igarashi, T., Ogata, T., & Fujita, T. (1992). Conserved mechanism of negative regulation by extracellular calcium. Parathyroid hormone gene versus atrial natriuretic polypeptide gene. *J. Clin. Invest.* 89, 1268–1273.
- Racke, F.K., & Nemeth, E.F. (1993). Protein kinase C modulates hormone secretion regulated by extracellular polycations in bovine parathyroid cells. *J. Physiol.* 468, 141–162.
- Russell, J., Lettieri, D., & Sherwood, L.M. (1983). Direct regulation by calcium of cytoplasmic messenger ribonucleic acid coding for pre-proparathyroid hormone in isolated bovine parathyroid cells. *J. Clin. Invest.* 72, 1851–1855.
- Shoback, D.M., & Chen, T. (1990). Effects of protein kinase C activation on inositol phosphate generation and intracellular Ca²⁺ mobilization in bovine parathyroid cells. *Endocrinology* 127, 141–148.
- Silver, J., Russell, J., & Sherwood, L.M. (1985). Regulation by vitamin D metabolites of messenger ribonucleic acid for preproparathyroid hormone in isolated bovine parathyroid cells. *Proc. Natl. Acad. Sci. USA* 82, 4270–4273.
- Sun, F., Ritchie, C.K., Hassager, C., Maercklein, P., & Fitzpatrick, L.A. (1993). Heterogeneous response to calcium by individual parathyroid cells. *J. Clin. Invest.* 91, 595–601.
- Watson, P.H., Wang, K.K., & Hanley, D.A. (1991). *In vitro* proteolysis of bovine parathyroid hormone by human erythrocyte calpain I. *J. Bone Miner. Res.* 6 (Suppl 1), S179.

- Watson, P.H., Mortimer, S.T., Tanguay, K.E., & Hanley, D.A. (1992). Activation and inhibition of protein kinase C in cultured bovine parathyroid cells: effect on the release of C-terminal fragments of parathyroid hormone. *J. Bone Miner. Res.* 7, 667–674.

RECOMMENDED READINGS

- Brown, E.M. (1994). In: *The Parathyroids* (Bilezikian, J.P., Marcus, R., & Levine, M.A., Eds.), pp. 15–54. Raven Press, New York.
- Kronenberg, H.M., Bringhurst, F.R., Segre, G.V., & Potts, Jr. J.T. (1994). In: *The parathyroids* (Bilezikian, J.P., Marcus, R., & Levine, M.A., Eds.), pp. 125–137. Raven Press, New York.
- Pocotte, S.L., Ehrenstein, G., & Fitzpatrick, L.A. (1991). Regulation of parathyroid hormone secretion (Review). *Endocr. Rev.* 12, 291–301.
- Silver, J., & Naveh-Many, T. (1994). Regulation of parathyroid hormone synthesis and secretion (Review). *Semin. Nephrol.* 14, 175–194.
- Watson, P.H., & Hanley, D.A. (1993). Parathyroid hormone: Regulation of synthesis and secretion (Review). *Clin. Invest. Med.* 16, 58–77.

This Page Intentionally Left Blank

Chapter 8

The Adrenal Medulla

STEPHEN W. CARMICHAEL

Introduction	207
Gross Anatomy of the Adrenal Medulla	208
Histology of the Adrenal Medulla	211
Structure of the Chromaffin Cell	213
Pathology of the Adrenal Medulla	215
The Adrenal Medulla as a Model System for Neurobiology	216
The Chromaffin Vesicle	216
Biosynthesis of Catecholamines	218
Uptake of Catecholamines into Chromaffin Vesicles	220
Stimulus–Secretion Coupling	221
Transplantation of the Adrenal Medulla for Parkinson’s Disease	223
Summary	223

INTRODUCTION

The adrenal medulla is situated at the interface between the endocrine system and the nervous system. This organ can clearly be classified as an endocrine organ

Principles of Medical Biology, Volume 10A
Molecular and Cellular Endocrinology, pages 207–225.
Copyright © 1997 by JAI Press Inc.
All rights of reproduction in any form reserved.
ISBN: 1-55938-815-3

because it delivers its secretions directly into the bloodstream; on the other hand, the parenchyma of the adrenal medulla, the chromaffin cells, are modified post-ganglionic sympathetic neurons. The adrenal medulla can therefore be thought of as a *modified sympathetic ganglion*, modified to the extent that its neurotransmitters are secreted into the bloodstream, rather than delivered to the target organ by long axons.

This functional characteristic of the adrenal medulla also makes it a valuable model for neuroscience research since it contains a relatively homogeneous group of cells with neuronal components. This is unusual in the nervous system, where neuronal elements are characteristically spread over variable distances. This chapter will discuss the position of the adrenal medulla in the morphology and physiology of the human body, then present some of the current thinking concerning how this organ contributes to our understanding of the nervous and endocrine systems.

GROSS ANATOMY OF THE ADRENAL MEDULLA

The very name *adrenal medulla* gives us important information about the anatomy of this organ. The term adrenal means next to (ad-) the kidney (-renal). Actually, the technically correct term for the human organ is *suprarenal medulla* (supra = above), but because so much research on this organ is done in quadrupedal mammals where it is “next to” the kidney, the term adrenal medulla is used universally. Medulla is a general term meaning “core.” In contrast, the term cortex means outer part or “bark” (as in the bark of a tree). Therefore, the name adrenal medulla tells us that it forms the core of an organ (the adrenal gland) that is next to the kidney.

There is a pair of adrenal glands, designated left and right. Each adrenal gland weighs 3 to 6 grams and is located on the superomedial pole of the corresponding kidney. The left adrenal gland is usually shaped like a croissant, and the right gland is more pyramidal (see Figure 1). The left adrenal gland is in contact with the diaphragm behind and the peritoneum of the lesser sac in front, and the splenic artery runs across the lower portion of the gland. The right adrenal gland is in contact with the diaphragm behind, the liver, inferior vena cava, and peritoneum of the hepatorenal pouch in front.

The *arterial supply* to each adrenal gland comprises numerous small arteries that derive from the inferior phrenic artery above the suprarenal artery (or arteries) medially, and the renal artery below. The number and pattern of these arteries are highly variable, but suffice it to say that the gland is richly vascularized. The arteries ramify directly beneath the capsule of the gland and separate systems supply the cortex and the medulla. Contrary to previously held views, there is no portal system whereby blood drains from the adrenal cortex to the medulla. However, there is continuity between venous radicles draining the cortex and the capillary plexus of the medulla that apparently functions like a portal system. This is an important

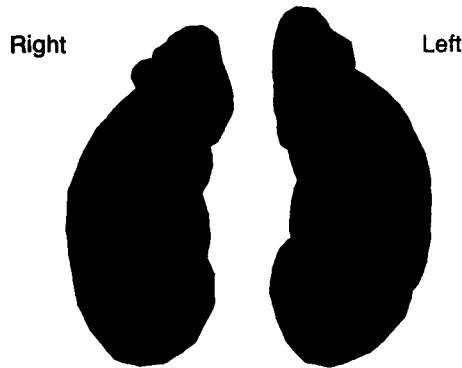

Figure 1. Schematic of adrenal glands above the kidneys.

point, since, as we will see later, adrenocortical steroids influence the synthesis of catecholamines in the adrenal medulla.

As with other endocrine organs, the adrenal gland has a particularly rich vascular supply. A clinical consequence of this is that tumors or infections that spread through the circulatory system have a high probability of spreading to this gland. Cancer of the adrenal glands is relatively common due to hematogenous metastasis. Such secondary tumors affect both the adrenal cortex and medulla.

Research with animal models has demonstrated that the blood flows to the adrenal cortex and medulla are somewhat independent. In circumstances that may become life-threatening (such as hemorrhagic hypotension), blood flow to the medulla is increased, whereas flow to the cortex remains the same, or is even diminished. This makes physiologic sense since the catecholamines from the medulla have the effect of increasing blood pressure, thereby attempting to counteract the hypotension in the organism. Adrenal cortical secretions can be important, but are not as active in acute situations.

The *venous drainage* from each adrenal gland, in contrast to the multiple supplying arteries, is accomplished by a single relatively large vein, appropriately called the adrenal (or suprarenal) vein. It begins as a central vein within the substance of the medulla, and as pointed out above, receives venous radicles from the cortex and a capillary plexus from the medulla. Both human adrenal veins drain into the inferior vena cava, but since this large vein is a right-sided structure, the left adrenal vein must do so indirectly. The left adrenal vein drains into the left renal vein, which crosses in front of the aorta to enter the inferior vena cava. The right adrenal vein is quite short, draining directly into the inferior vena cava. It is important to note the position within the circulatory system that the adrenal glands enjoy due to their venous drainage. The point here is that secretions from the adrenal medulla, which are well known to have a positive inotropic effect on the heart, enter

the circulation at a point just distal to the heart. It has been postulated, but not proven, that catecholamines such as epinephrine can exert their effects from within the chambers of the heart. If this is true, then adrenal medullary secretions are literally only a heartbeat away from influencing the heart. At the very least, as soon as catecholamines pass through the pulmonary circulation and the left side of the heart, they would enter the coronary arteries where they clearly have an effect.

The *innervation* of the adrenal medulla is key to its function. Since we have considered the adrenal medulla to be a modified sympathetic ganglion, it is not surprising that it is innervated in the same pattern as other sympathetic ganglia. That is, adrenal chromaffin cells are innervated by preganglionic sympathetic neurons that have their cell bodies in the intermediolateral cell column of the spinal cord. For the most part, these preganglionic neurons arise from thoracic segments 5 through 9 and traverse the greater thoracic splanchnic nerve. At a point at or proximal to the celiac ganglion, fibers branch off to supply the nearby adrenal gland. Innervation of the adrenal cortex is controversial; nerves may be limited to supply-

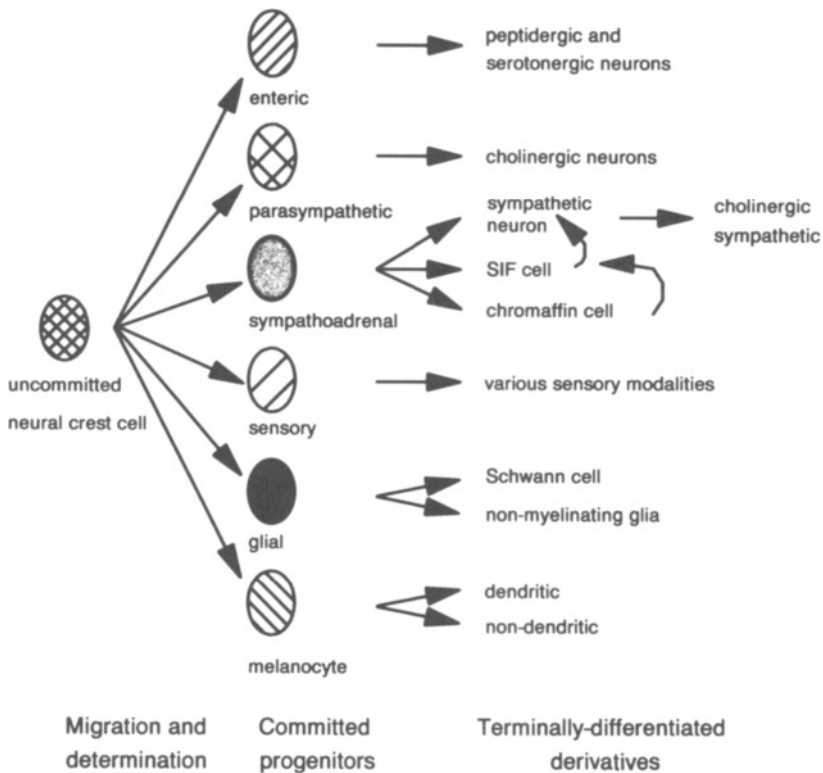

Figure 2. Schematic of neural crest cell lineage. (Modified from Anderson, 1989).

ing cortical vasculature. Innervation of chromaffin cells by these preganglionic fibers is well documented. There is evidence that some chromaffin cells receive direct innervation, whereas other chromaffin cells are indirectly innervated via gap junctions with neighboring chromaffin cells. Furthermore, recent evidence suggests that afferent fibers supply the adrenal medulla. Whereas the function of such sensory fibers is not yet appreciated, it is intriguing to speculate on the possibilities of neural feedback to this organ.

The presence of *lymphatic drainage* from the human adrenal medulla has not been established, although lymphatics from the adrenal cortex have been demonstrated by the spread of neoplasms from this organ. Indirect physiologic evidence in an animal model has suggested that larger molecules secreted from the adrenal medulla enter the thoracic duct, but 99% of catecholamines, which are relatively small molecules, enter the adrenal vein directly.

The *embryology* of the adrenal medulla is homologous to sympathetic ganglia. The chromaffin cells arise from the neural crest, as do all post-ganglionic neurons (see Figure 2), and migrate ventrally to associate with the cortical anlage. Cortical steroids influence the development of the chromaffin cells in two important ways: (1) they activate the enzyme that converts norepinephrine to epinephrine (phenylethanolamine *N*-methyltransferase), thereby enabling the adrenal medulla to secrete a more active catecholamine; and (2) steroids prevent chromaffin cells from extending processes so that they remain more compact. This latter point is the crucial morphologic difference between chromaffin cells and other post-ganglionic neurons.

HISTOLOGY OF THE ADRENAL MEDULLA

Whereas the adrenal cortex is arranged in three zones that differ in their histologic appearance, the human adrenal medulla is considered as a single zone. The best descriptive terms to describe the arrangement of cells within the medulla is “cords and clumps”, implying an irregular arrangement. That gives an accurate impression. Each chromaffin cell is thought to be polarized, although this is not usually apparent in a single section. The picture that can be reconstructed from serial sections is that of a cell receiving its innervation at one pole, and abutting against a wide fenestrated capillary on the other (see Figure 3). The structure of the chromaffin cell will be described in more detail below.

If during histologic preparation the adrenal medulla is treated with chromium salts, it takes on a characteristic yellowish color that contrasts with the cortex. This is significant because the term “chromaffin” derives from the color of this tissue when treated with chromium. There are other chromaffin tissues in the body in addition to the adrenal medulla, and they share many of the features of adrenal chromaffin cells. Another important color term that is associated with the adrenal medulla is seen in the word pheochromocytoma (*phaios* is Greek for a shade of brown), the most common tumor of the adrenal medulla.

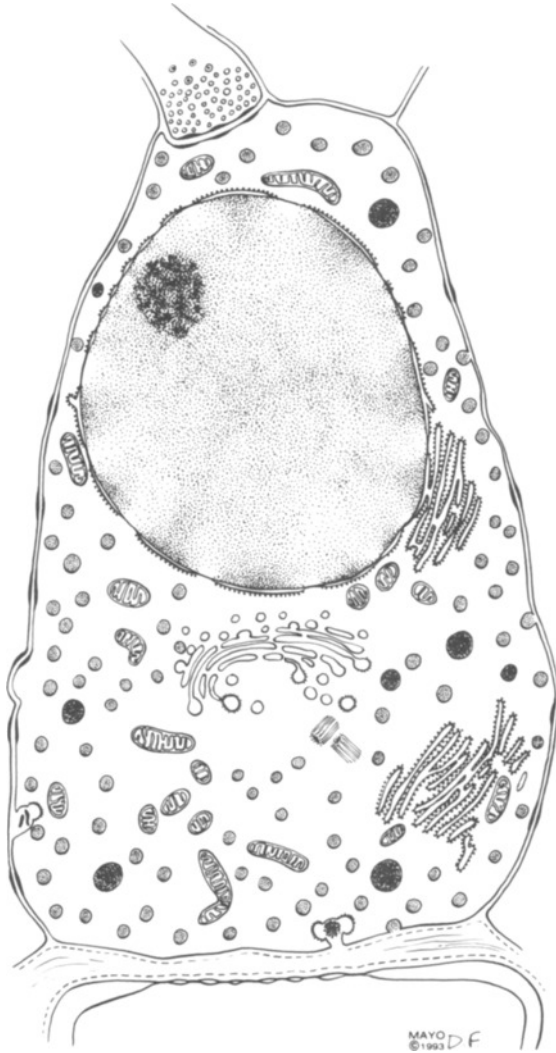

Figure 3. Schematic of an epinephrine-containing cell demonstrating its relationship to a nerve terminal and a capillary. (Modified from Carmichael, 1987).

Other histochemical treatments of the adrenal medulla demonstrate that separate chromaffin cells contain different catecholamines—the three types of catecholamines found in chromaffin cells being epinephrine (the British term “adrenaline” is also commonly used), norepinephrine (the British term is “noradrenaline”), and dopamine. The existence of epinephrine-containing cells and norepinephrine-containing cells is well established. There may also be a few dopamine-containing cells

that are similar to “small intensely fluorescent” cells (often just called SIF cells) found elsewhere in the body.

The adrenal medulla contains a relatively homogeneous population of chromaffin cells. However, there are other cells in this organ. The next most common cell is the endothelial cell that lines all of the blood vessels. Since the adrenal medulla is a richly vascular organ, it is logical that endothelial cells are abundant. We are just beginning to explore the importance of endothelial cells in the adrenal medulla. Endothelial cells are interposed between chromaffin cells and the bloodstream and may influence the passage of secreted molecules.

The role of additional cells in the adrenal medulla is even more poorly understood. Fibroblasts and other connective tissue cells are present, but are considered to have only a physically supportive role in the organ. The adrenal medulla is rather “mushy”, which is consistent with the paucity of supporting cells and fibers. Ganglion cells are occasionally seen in the adrenal medulla. These cells are histologically distinct, being large with a prominent nucleus and nucleolus. However, the function of ganglion cells in the adrenal medulla is a complete mystery.

STRUCTURE OF THE CHROMAFFIN CELL

It has long been appreciated that the cytoplasm of chromaffin cells has a “grainy” appearance when viewed with the light microscope. This is due to the fact that the cytoplasm is packed with about 25,000 small catecholamine-containing organelles. For years these organelles were called “granules”, which means “little grains”. However, it was demonstrated by electron microscopy that these “granules” are actually membrane-bound structures. Therefore, they are now called *chromaffin vesicles*; the term vesicle means “little container”. The chromaffin vesicle was the first secretory vesicle to be isolated and studied, so it stands to reason that it is the best characterized secretory vesicle. As we will see below, this is indeed the case.

Interestingly, chromaffin vesicles appear differently when examined with the electron microscope depending on which type of catecholamine they contain. Epinephrine-containing vesicles appear less dense than the other two. Norepinephrine-containing vesicles have a dense core, often with a “halo” between the core and the membrane of the vesicle. It is well known that these differences are due to effects of chemical fixation on the chromaffin vesicles, and probably do not mean that the vesicles are different *in vivo*. The presence of a separate population of dopamine-containing vesicles is not well established, but much smaller, dense-cored vesicles are seen in a few cells. These cells have been called “small granule-containing” cells and may be the same as SIF cells. Since chromaffin cells are modified post-ganglionic sympathetic neurons, they have many of the same organelles as these neurons (see Figure 4). As in most cells, the nucleus is a conspicuous organelle and it usually contains a single nucleolus. A moderate amount of rough endoplasmic reticulum is present, as well as a modestly developed Golgi apparatus. This is consistent with the fact that chromaffin cells, like other neurons, synthesize

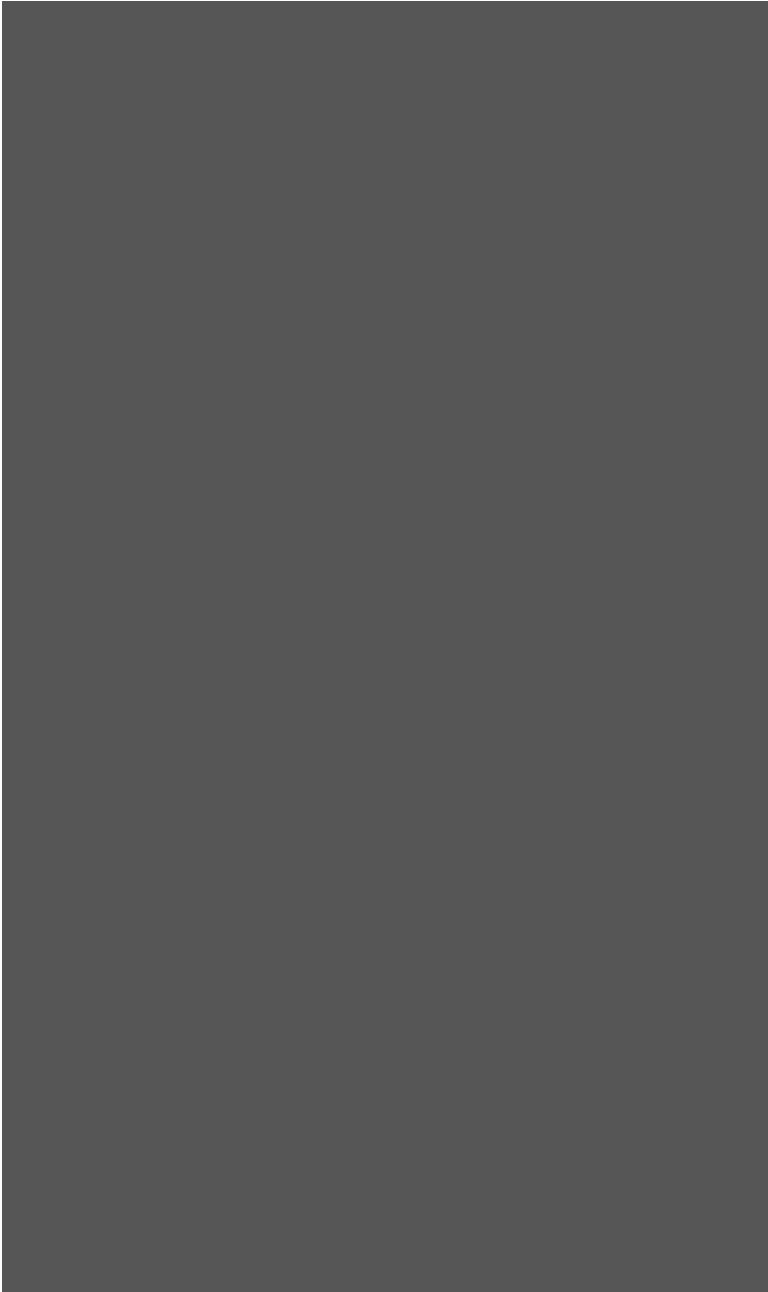

Figure 4. Electron micrographs of human adrenal medulla. Panel **A** magnification $\times 2,500$; **B** $\times 12,500$. (Supplied by John R. Hansen, University of Rochester).

proteins that are secreted. Mitochondria and other typical organelles are present in moderate amounts.

PATHOLOGY OF THE ADRENAL MEDULLA

Compared to other endocrine glands, the adrenal medulla is relatively disease-free. The most significant pathologic entity of the organ is the tumor called *pheochromocytoma*. As mentioned above, this term refers to a brown color. Although the precise prevalence of pheochromocytoma is not known, it has been estimated to be as high as 0.1% in patients with diastolic hypertension (Manger and Gifford, 1977). This sounds like a small number, but it suggests that 50,000 people, out of a patient population of 50 million, have this tumor in the United States. It has been estimated that about 700 patients in this country die of hypertension each year due to pheochromocytoma. Comparable estimates for other countries have been published.

Whereas the variety of clinical manifestations of pheochromocytoma have been described as kaleidoscopic, the common theme is episodes of hypertension known as *paroxysmal hypertension*. This is associated with a surge of catecholamines, predominantly norepinephrine, from the tumor that logically exerts an exaggerated sympathetic response. As you would expect, this response has the potential of being fatal. Most frequently the tumor is benign and involves a single adrenal medulla, but in about 10% of cases it is bilateral or multiple (involving extra-adrenal chromaffin tissue). In about 10% of cases the pheochromocytoma can be malignant, but this figure may be an overestimate. Generally, the malignant pheochromocytomas are slow growing, resistant to radiation therapy, and can metastasize to other organs.

The most important thing to remember about pheochromocytoma is that it is easily treated *if properly diagnosed*. It is curable in about 90% of patients, but it will eventually be lethal in almost all cases if untreated. The obvious treatment for a properly diagnosed pheochromocytoma is surgical resection. The “dictum” for pheochromocytoma is: “Think of it, confirm it, find it, and remove it” (Manger and Gifford, 1977).

There are other diseases of the adrenal medulla, but they are quite rare. They include *neuroblastoma*, a highly malignant tumor that usually occurs in children; about half of neuroblastomas involve the adrenal medulla. Some neuroblastomas are thought to transform into a benign tumor called a *ganglioneuroma*. Similarly, about half of these may involve the adrenal medulla.

The world literature on pheochromocytoma and other diseases of the adrenal medulla is extensive, with several comprehensive books available (i.e., Manger and Gifford, 1977). This brief overview of adrenal medullary pathology is far from exhaustive.

THE ADRENAL MEDULLA AS A MODEL SYSTEM FOR NEUROBIOLOGY

The information presented above is adequate for a beginning medical student. However, for the intellectually inquisitive the adrenal medulla has much more to offer. In fact, the adrenal medulla has been referred to as the "Rosetta Stone" of neurobiology because it presents a relevant and accessible model for neurobiologists. It consists of a relatively homogeneous population of neurons (chromaffin cells) that perform many of the typical functions of neurons found in the brain and other parts of the body. We will begin this section of the chapter with a closer look at the characteristic organelle of the adrenal chromaffin cell, the chromaffin vesicle.

THE CHROMAFFIN VESICLE

The chromaffin vesicle was first isolated in 1953, making it possible to study the biochemical composition of this vesicle. Since that time, not only have a number of molecules been detected within chromaffin vesicles, but their amounts have been quantified. As illustrated in Table 1¹, virtually the precise number of each of the many types of molecules within the chromaffin vesicle is known. Even more

Table 1. Number of Molecules per Chromaffin Vesicle

<i>Molecule</i>	<i>Number</i>
Dopamine β -hydroxylase	182
Chromogranin A	6545
Chromogranin B	8181
Enkephalins	11,636
Catecholamines	4,000,000
ATP	890,900
ADP	127,273
AMP	38,182
GTP	118,182
UTP	67,273
Calcium	120,000
Magnesium	34,545
Ascorbic acid	160,000
Sialic acid (glycoproteins)	78,182
Sulfated hexosamine (glycosaminoglycans)	45,455
Glucuronic acid (glycosaminoglycans)	45,455
Acid groups (in proteins at pH 5.5)	3,090,910
Basic groups (in proteins)	2,072,727
Amides in proteins	614,545
Net negative charge (of proteins at pH 5.5)	400,000

remarkably, the release of catecholamines from an individual chromaffin vesicle can be detected!

Catecholamines are the best understood of the contents of the chromaffin vesicles. The fact that they are secreted by the adrenal medulla was appreciated in the late 1800s, making the adrenal medulla the first endocrine gland to be discovered. They are neurotransmitters at many synapses, but must be considered hormones when they are secreted into the bloodstream by the adrenal medulla.

The other contents of the chromaffin vesicle are not as well understood. The molecules that are currently generating a lot of excitement are the *chromogranins*, a group of acidic proteins. These proteins were first discovered in chromaffin “granules”, hence the name chromogranins. The two species that are most abundant in chromaffin vesicles are chromogranin A and chromogranin B. Although chromogranins have been recognized for 25 years and are relatively abundant in the adrenal medulla, their function is still not established. One possibility is that these proteins complex with catecholamines and other molecules for storage in osmotically favorable conditions. Within their amino acid sequence, chromogranins have some biologically active peptides; perhaps chromogranins are precursor molecules. Current speculation is that these highly charged proteins behave as “smart gels”, and have a role in exocytosis (see below).

Another class of molecules stored in chromaffin vesicles are *enkephalins*. These recently discovered peptides have an analgesic effect on the organism. Enkephalins were the subject of intense study during the past decade and, interestingly enough, the adrenal medulla contains one of the highest concentrations of enkephalins in the body. To make a long and fascinating story short, it was demonstrated, in studies using the adrenal medulla of the cow (because it is large and yields a lot of material for biochemical analysis), that several short enkephalin molecules are included within the amino acid sequence of a larger molecule called proenkephalin, which in turn is first produced as an even larger molecule called preproenkephalin. Preproenkephalin is processed by certain enzymes (proteases) to yield several copies of [Met]enkephalin (which contains methionine in a certain position) and one copy of [Leu]enkephalin (which contains leucine in the same position). The important work on the synthesis of enkephalins was done with the adrenal medulla. As for the function of enkephalins secreted from the adrenal medulla, some animal studies suggest that they mediate *stress-induced analgesia*. This would imply that during severe stress, perhaps just prior to death, the perception of pain would be diminished. Perhaps the adrenal medulla contributes to an easy exit.

Although we have focused on some of the soluble contents of the chromaffin vesicle, the vesicle membrane is also well characterized. Rather than delving into the realm of membrane biophysics, suffice it to say that studies of membrane fusion and fission have benefited from the use of chromaffin vesicle membranes.

BIOSYNTHESIS OF CATECHOLAMINES

Although catecholamines are synthesized, stored, and secreted at several places in the body, the reader should not be surprised to learn that the pioneer studies on the biosynthesis of catecholamines employed the adrenal medulla. As it turned out, the biosynthetic pathway is short.

As seen in Figure 5, the amino acid tyrosine enters the chromaffin cell where it is converted to 3,4-dihydroxyphenylalanine (universally referred to by the acronym DOPA) by the enzyme tyrosine hydroxylase. This is important because this step is considered to be the rate-limiting step in the synthesis of norepinephrine or epinephrine. Therefore, tyrosine hydroxylase is the rate-limiting enzyme, and the amount or activity of this enzyme determines the amount of catecholamines produced.

The conversion of DOPA to dopamine does not control the synthesis of catecholamines since the converting enzyme (DOPA decarboxylase) is ubiquitous and has a high activity. Any DOPA that is formed is rapidly converted to dopamine.

From here the story gets interesting since the enzyme that converts dopamine to norepinephrine (dopamine β -hydroxylase) is not located anywhere else in the cell except within the chromaffin vesicle. Actually about half of the dopamine β -hydroxylase exists as a soluble enzyme, the other half is bound to the inside of the chromaffin vesicle membrane. This means that dopamine must be transported into

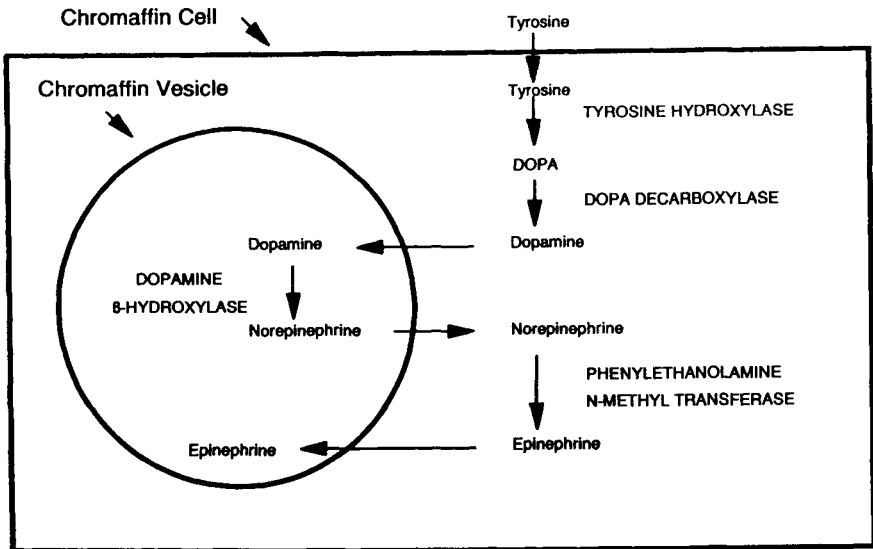

Figure 5. Biosynthetic pathway of epinephrine within the chromaffin cell. (Modified from Carmichael, 1983).

the vesicle before it can be converted to norepinephrine. We will look at this transport mechanism later. Once inside the vesicle, all sorts of interesting things happen. In short, electrons are transferred into the vesicle via a membrane protein called cytochrome b_{561} , and, with ascorbic acid as an intermediary, the electrons are transferred to dopamine. This is shown in more detail in Figure 6.

The methylation of norepinephrine to epinephrine is catalyzed by phenylethanolamine *N*-methyltransferase, which is logically referred to by its acronym PNMT. One of the interesting things about PNMT is that it is made more active by cortical steroids. The significance of this is that the surrounding adrenal cortex plays an important role in influencing the medulla to secrete epinephrine, which is generally more active as a hormone than norepinephrine. The alert reader will deduce that PNMT is present in some (the epinephrine-containing) chromaffin cells, but not present in others (the norepinephrine- and dopamine-containing cells).

Curiously, PNMT is a cytosolic enzyme, so norepinephrine moves down its concentration gradient (i.e. leaks out of the chromaffin vesicle) and is converted to epinephrine in the cytosol (see Figure 5). Of course we know that epinephrine is not stored in the cytosol, but rather in chromaffin vesicles, so how is epinephrine concentrated within these vesicles?

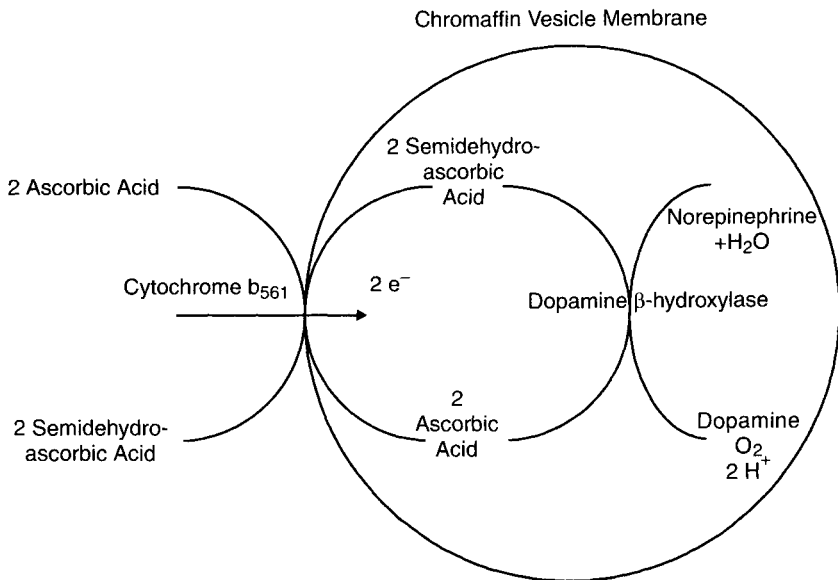

Figure 6. Electron transfer involved in the conversion of dopamine to norepinephrine. (Modified from Levine et al., 1989).

UPTAKE OF CATECHOLAMINES INTO CHROMAFFIN VESICLES

The epinephrine concentration within the chromaffin vesicle is about 2000 times greater than in the cytosol. It obviously requires energy to move epinephrine up this formidable concentration gradient, but the mechanism for this has been a puzzle. This biologic problem vexed neurobiologists for a decade. It was demonstrated in the late 1970s that a coupled transport system was involved. This mechanism is similar to the chemiosmotic mechanism involved in the synthesis of ATP in the mitochondrion. As illustrated in Figure 7, protons (which are equivalent to hydrogen ions, hence the symbol H^+) are driven into the chromaffin vesicle by an ATPase molecule in the vesicle membrane; this process consumes ATP. More protons within the vesicle create an *electrochemical gradient*, with a positive electric potential inside (about 70 mV) and a lower pH inside (pH about 5.5 inside the vesicle, 7.3 in the cytosol outside the vesicle). Remembering that pH signifies the negative log of the hydrogen ion concentration, we see that there are about 100 times more protons inside the vesicle than outside. This gradient drives the uptake of dopamine and epinephrine into the chromaffin vesicle.

As we can see in Table 1, there are some other molecules that are available in the cytosol that are stored in chromaffin vesicles. Nucleotides (ATP, ADP, AMP, GTP, and UTP) are taken up into chromaffin vesicles; this process is powered by the proton gradient. Apparently, only the electrical portion of the gradient is necessary.

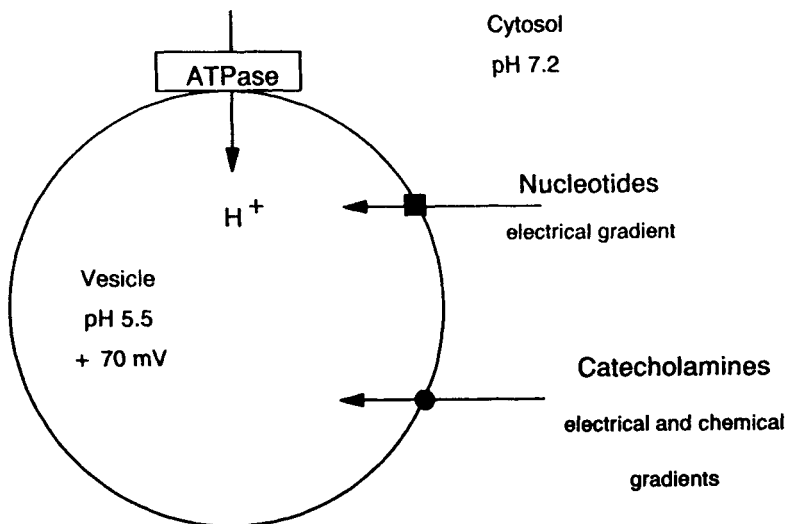

Figure 7. A proton gradient drives the uptake of catecholamines and nucleotides. (Modified from Carmichael, 1983).

STIMULUS–SECRETION COUPLING

The ultimate “job” of the adrenal medulla is to secrete catecholamines into the bloodstream as part of a sympathetic response. Like other post-ganglionic neurons, adrenal chromaffin cells must respond to a neural signal by releasing a transmitter. The cascade of events that are required for this to happen has been termed *stimulus–secretion coupling*, a term derived from stimulus–contraction coupling of muscle physiology. Whereas stimulus–secretion coupling probably is applicable to all secreting cells, the term was coined in reference to secretion from adrenal chromaffin cells. To say that this process is complicated would be an understatement. The essential elements of stimulus–secretion coupling in the adrenal medulla are: (1) the arrival of a signal (neurotransmitter) at the surface of the chromaffin cell; (2) interaction between this neurotransmitter and a receptor on the cell surface; (3) a change in the cell surface to permit ions (sodium, calcium, and perhaps potassium) to cross; and (4) the involvement of substances (called *second messengers*) within the cell that react to the change in the ionic environment and somehow influence the chromaffin vesicles to “dock” at the plasma membrane and release their contents. This release mechanism is called *exocytosis* (meaning “outside the cell”), and is illustrated in Figure 8.

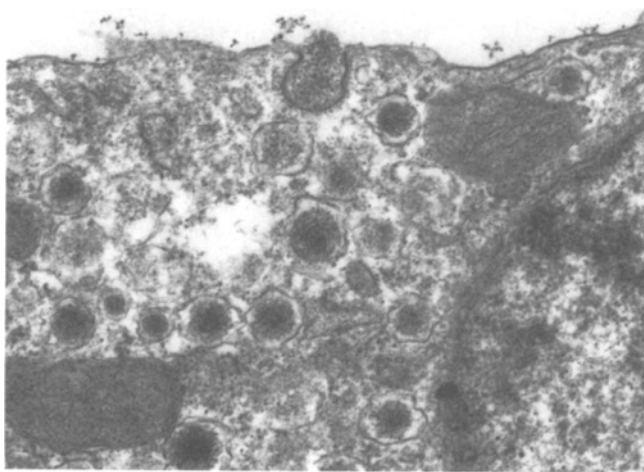

Figure 8. Electron micrograph of exocytosis in adrenal medulla of rat. Magnification $\times 30,000$.

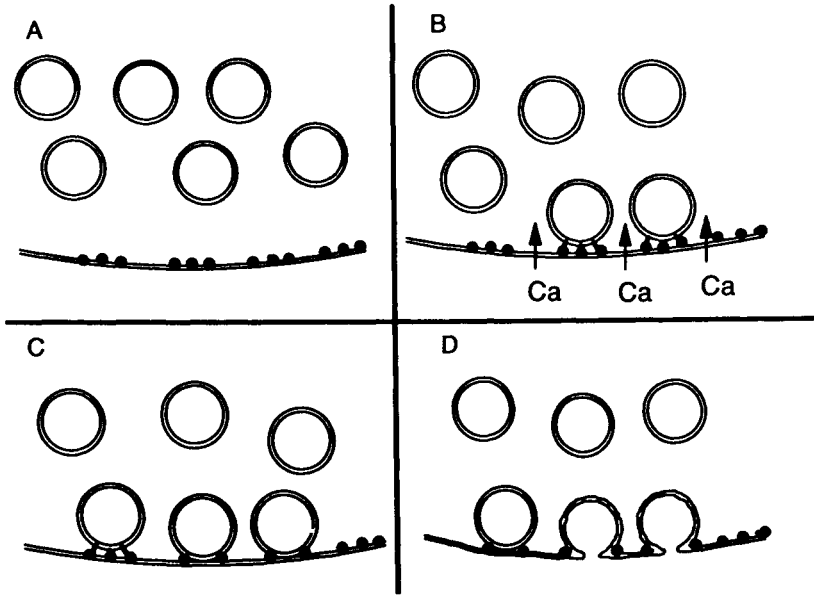

Figure 9. A scheme of stimulus-secretion coupling. (Adapted from Nakata et al., 1990).

The simplest version of this scenario is that acetylcholine, released from a preganglionic neuron, interacts with a receptor on the chromaffin cell membrane. This interaction opens a channel in the membrane that allows calcium ions to rush in. The sudden increase in intracellular calcium affects molecules within the cytosol that bring about an interaction between the chromaffin vesicle membrane and the cell membrane. As shown in Figure 9, globular proteins are associated with the inside of the cell membrane (panel A). Upon stimulation, calcium enters the cell (B). This leads to the chromaffin vesicles attaching to the proteins (C), and hence exocytosis (D).

Although current theories of stimulus-secretion coupling involve many additional intermediate steps, one recent twist is the possibility that chromogranins act as “smart gels”. Smart gels are highly charged proteins that are physically altered when their electrical environment is changed (Nanavati and Fernandez, 1993).

This could take the form of a vesicle containing a smart gel enlarging in response to more cations in the immediate vicinity. Perhaps as calcium and/or other cations increase in the vicinity of a chromaffin vesicle the chromogranins inside expand, resulting in an “explosive” discharge of vesicle contents—exocytosis.

It should be apparent that the details of stimulus-secretion coupling have not been worked out. This is also true for cells other than the adrenal chromaffin cell.

Whatever the mechanism of stimulus–secretion coupling, studies with adrenal chromaffin cells will help elucidate it.

TRANSPLANTATION OF THE ADRENAL MEDULLA FOR PARKINSON'S DISEASE

An interesting clinical role for the adrenal medulla has been in the treatment of Parkinson's disease. This debilitating disease is marked by degeneration of dopaminergic neurons that originate in the substantia nigra of the brainstem and project to the striatum. When these neurons are lost there is a decrease of dopamine in the striatum and the patient presents with characteristic motor signs. It is logical that if dopamine-producing cells could be transplanted to the striatum to correct the deficiency, symptoms would improve. As we know, the adrenal medulla produces dopamine as a precursor to norepinephrine and epinephrine. Furthermore, if the adrenal medulla were carefully separated from cortex prior to transplantation, the steroids that encourage the production of epinephrine would be minimized, making dopamine relatively abundant. In the late 1980s, it was claimed that two parkinsonian patients benefited substantially from the autologous transplantation of one adrenal medulla to the brain. This procedure was repeated in many patients, but the benefits were modest at best. Whereas the reasons that this approach was not effective remain elusive, many scientists are optimistic that adrenal chromaffin cells may be an effective substitute for the dopaminergic neurons that are lost in parkinsonian patients.

SUMMARY

The adrenal medulla is the central portion of the adrenal gland. The parenchyma of the adrenal medulla is composed of chromaffin cells, which are modified postganglionic sympathetic neurons. These cells secrete catecholamines into the bloodstream, and have the general effect of preparing the body for "fight or flight." Diseases of the adrenal medulla are relatively rare; the most common is a tumor of chromaffin cells called pheochromocytoma. Clinically, this condition accounts for 0.1% of the cases of hypertension. The adrenal medulla is not essential for life, but it has proven to be an important model system for neurobiologists. For example, the chromaffin vesicle (the secretory vesicle of chromaffin cells) has been characterized down to a relatively precise number of molecules within the vesicle. Molecules such as chromogranins and enkephalins have been extracted from the adrenal medulla and studied in detail. The biosynthesis of catecholamines was elucidated in studies utilizing the adrenal medulla. The phenomena of vesicular uptake and stimulus–secretion coupling have been studied using the adrenal chromaffin cell. Finally, the adrenal medulla has been autologously transplanted into the human brain in an attempt to relieve the symptoms of Parkinson's disease.

ACKNOWLEDGMENTS

The author thanks Drs. Sheldon Sheps, Susan Stoddard, and Gertrude Tyce for reviewing the manuscript.

NOTE

¹Data abstracted from Winkler and Westhead (1980), Winkler, Apps, and Fischer-Colbrie (1986), Nordmann (1984), and Gill et al. (1991). This Table is not included for students to memorize, but rather to illustrate the extraordinary degree to which the chromaffin vesicle has been characterized.

REFERENCES

- Anderson, D.J. (1989). The neural crest cell lineage problem: Neurogenesis? *Neuron* 3, 1–12.
- Carmichael, S.W. (1983). The adrenal chromaffin vesicle as a biological model: An historical perspective. *J. Auton. Nerv. Syst.* 7, 7–12.
- Carmichael, S.W. (1987). Morphology and innervation of the adrenal medulla. In: *Stimulus–Secretion Coupling in Chromaffin Cells* (Rosenheck, K., & Lelkes, P. I., Eds.), pp. 1–29. CRC Press, Boca Raton, FL.
- Gill, B.M., Barbosa, J.A., Dinh, T.Q., Garrod, S., & O'Connor, D.T. (1991). Chromogranin B: Isolation from pheochromocytoma, N-terminal sequence, tissue distribution and secretory vesicle processing. *Regul. Peptides* 33, 223–235.
- Levine, M., Hartzell, W.O., Dhariwal, K.R., Washko, P.W., & Bergsten, P. (1989). Ascorbic acid regulation of norepinephrine biosynthesis *in situ*. In: *Molecular Biology of Stress: UCLA Symposia on Molecular and Cellular Biology. New Series* (Brennitz, S., & Zinder, O., Eds.), Vol. 97, pp. 191–201. Alan R. Liss, New York.
- Manger, W.M., & Gifford, R.W., Jr. (1977). *Pheochromocytoma*, pp. 398. Springer-Verlag, New York.
- Nordmann, J.J. (1984). Combined stereological and biochemical analysis of storage and release of catecholamines in the adrenal medulla of the rat. *J. Neurochem.* 42, 434–437.
- Nakata, T., Sobue, K., & Hirokawa, N. (1990). Conformational change and localization of calpactin I complex involved in exocytosis as revealed by quick-freeze, deep-etch electron microscopy and immunocytochemistry. *J. Cell Biol.* 110, 13–25.
- Nanavati, C., & Fernandez, J.M. (1993). The secretory granule matrix: A fast-acting smart polymer. *Science* 259, 963–965.
- Winkler, H., Apps, D.K., & Fischer-Colbrie, R. (1986). The molecular function of adrenal chromaffin granules: Established facts and unresolved topics. *Neuroscience* 18, 261–290.

RECOMMENDED READINGS

- Ahlskog, J.E. (1993). Cerebral transplantation for Parkinson's disease: Current progress and future prospects. *Mayo Clinic Proc.* 68, 578–591.
- Carmichael, S.W. (1989). The history of the adrenal medulla. *Rev. Neurosciences* 2, 83–99.
- Carmichael, S.W. (1993). Cytochemistry of the adrenal medulla. In: *Electron Microscopic Cytochemistry and Immunocytochemistry in Biomedicine* (Ogawa, K., & Barka, T., Eds.), pp. 562–583. CRC Press, Boca Raton, FL.
- Carmichael, S.W., & Stoddard, S.L. (1993). *The Adrenal Medulla, 1989–1991*. CRC Press, Boca Raton, FL.
- Carmichael, S.W., & Winkler, H. (1985). The adrenal chromaffin cell. *Scientific American* 253, 40–49.

- Nussdorfer, G.G. (1996). Paracrine control of adrenal cortical function by medullary chromaffin cells. *Pharm. Rev.* 48, 495–530.
- Winkler, H., & Carmichael, S.W. (1982). The chromaffin granule, In: *The Secretory Granule* (Poisner, A., & Trifaró, J. M., Eds.), pp. 3–79. Elsevier/North Holland Biomedical Press, Amsterdam.
- Winkler, H., & Fischer-Colbrie, R. (1992). The chromogranins A and B: The first 25 years and future perspectives. *Neuroscience* 49, 497–528.

This Page Intentionally Left Blank

Chapter 9

The Adrenal Cortex

LOUISA LAUE* and GORDON B. CUTLER, JR.

Introduction	228
Morphology of the Adrenal Cortex	228
Embryology	228
Anatomy	229
Histology	230
Steroid Biosynthesis	232
Glucocorticoids	232
Mineralocorticoids	236
Adrenal Sex Steroids	237
Physiology of Adrenal Steroids	238
Glucocorticoids	238
Mineralocorticoids	241
Adrenal Sex Steroids	242
Histopathology	242
Nonfunctional Adrenal Tumors	242
Adrenocortical Hyperfunction	243
Adrenocortical Hypofunction	249
Summary	253

*Deceased

Principles of Medical Biology, Volume 10A
Molecular and Cellular Endocrinology, pages 227–254.
Copyright © 1997 by JAI Press Inc.
All rights of reproduction in any form reserved.
ISBN: 1-55938-815-3

INTRODUCTION

The adrenal glands are paired organs adjacent to the kidneys which are comprised of a cortex and a medulla. This chapter will review the embryology, anatomy, physiology, and histopathology of the adrenal cortex as they relate to disorders of adrenal function.

MORPHOLOGY OF THE ADRENAL CORTEX

Embryology

The adrenal cortex develops from primitive mesoderm. By week 4 of gestation an aggregate of mesenchymal cells is visible between the root of the dorsal mesentery and the developing gonad. These cells penetrate the retroperitoneal mesenchyme and develop into the fetal cortex. By week 7 of gestation, cells from adjacent sympathetic ganglia migrate along nerve fibers to the developing cortex. These cells become encapsulated by the cortex and differentiate into the medulla. By week 8, additional cells from the coelomic epithelium enclose the fetal cortex giving rise to two distinct zones of the adrenal cortex: a large inner fetal zone and a thin outer adult zone.

During the second and third month of gestation, cells of the fetal cortex continue to proliferate and the adrenal gland increases in weight to about 80 mg. At this stage, the fetal adrenal is larger than the kidney. After week 20 of gestation, continued growth and differentiation of the cortex is ACTH-dependent. The fetal adrenal cortex from an anencephalic fetus is atrophic. At term each adrenal gland weighs 2–4 grams. After birth, the fetal cortex involutes. The outer adult cortex remains and ultimately differentiates into three definitive zones: the *zona glomerulosa*, *zona fasciculata*, and *zona reticularis*. (Figure 1)

Steroidogenesis in the fetal adrenal differs from the adult in that there is a reduction in 3β -hydroxysteroid dehydrogenase (3β -HSD) activity. This results in excess production of dehydroepiandrosterone (DHEA) and other Δ^5 - 3β -hydroxysteroids (mainly in the form of sulfate conjugates). These steroids are converted to estrogens by the placenta. Cortisol is produced primarily by the outer adult zone. Enzymatic defects along the pathway of cortisol biosynthesis result in hyperplasia of the adrenal cortex (*congenital adrenal hyperplasia*, CAH). Depending on the specific enzyme deficiency, CAH is manifested clinically at birth as male or female pseudohermaphroditism.

During development, primitive adrenal cortical cells can migrate and form *adrenal rest tissue* anywhere from the mediastinum to the scrotum. The most common sites for adrenal rests are the kidney, celiac plexus, broad ligament, ovarian and spermatic vessels, uterus, and testes. Less common sites include abdominal organs, lungs, spinal nerves, and brain. Adrenal rest tissue has all the enzymatic machinery for steroidogenesis and is responsive to ACTH stimulation. It should be

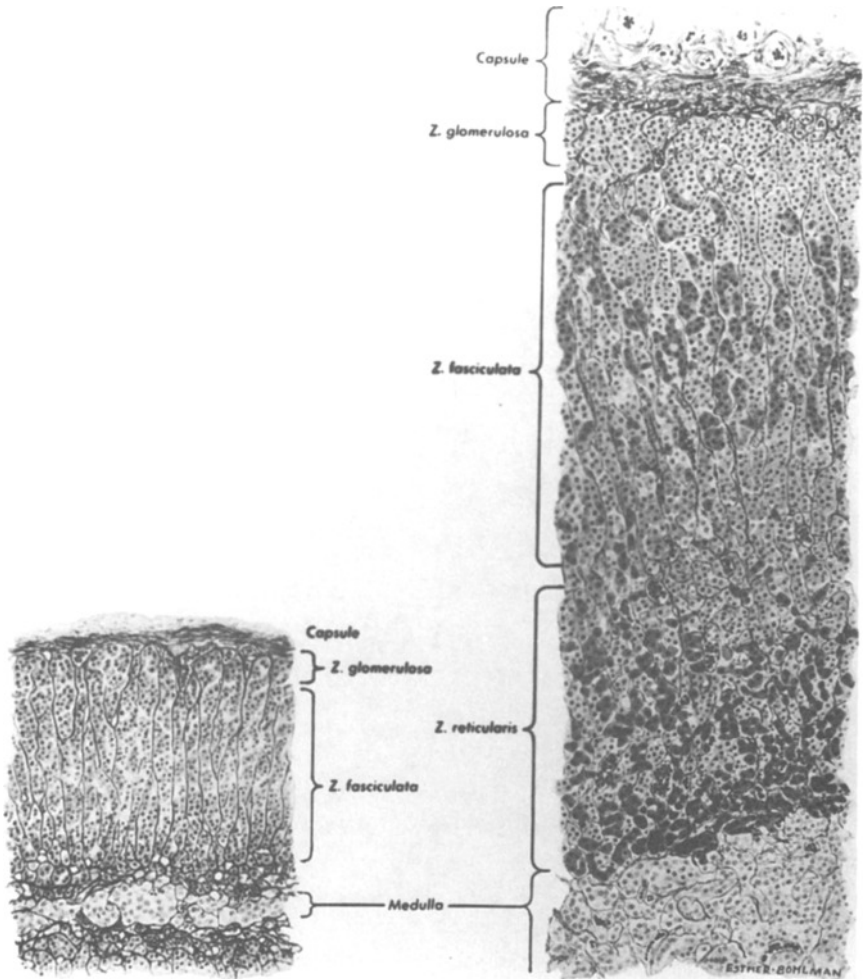

Figure 1. Sections through the adrenal glands of a 6-month-old infant (*left*) and of a man (*right*). Mallory-azan stain. $\times 110$.

suspected when Cushing's disease (ACTH-producing pituitary tumor) recurs in patients following bilateral adrenalectomy or when gonadal enlargement occurs in patients with Nelson's syndrome (hyperpigmenting, ACTH-producing pituitary tumor following adrenalectomy) or CAH.

Anatomy

The adrenal glands lie in the retroperitoneal space, anteromedial to the upper pole of the kidneys, between the level of the eleventh thoracic and first lumbar vertebrae.

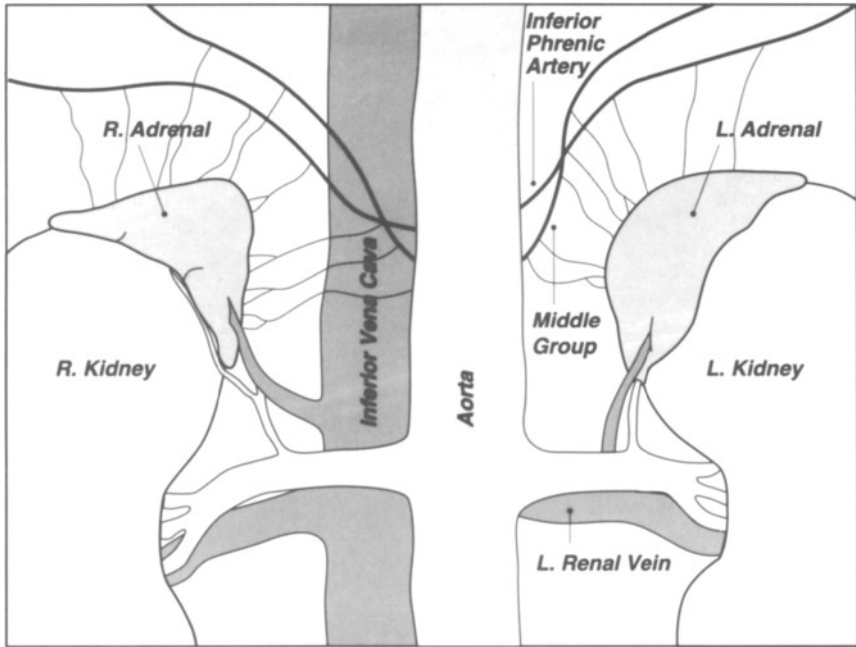

Figure 2. Schematic of the anatomy of the adrenal gland showing blood supply. Note multiple arterial twigs that penetrate the adrenal cortex from several angles, and single adrenal vein which empties on the left into the left renal vein and on the right into the vena cava.

An adult adrenal gland weighs 3.5–5.0 g and averages $5.0 \times 2.5 \times 0.6$ cm in size. Each gland has a head (which lies inferiorly and contains most of the medulla), a body, and a tail (which contains only cortex; see Figure 2).

The adrenal gland is well vascularized. Numerous small arteries arising from the inferior phrenic artery, aorta, and renal arteries supply the surface of the gland, penetrate the capsule, and organize into a subcapsular plexus at the corticomedullary junction. There they form a type of portal circulation which drains through the medulla into a central vein. This vein empties into the inferior vena cava on the right and the renal vein on the left. Sampling of adrenal venous effluent is often performed to facilitate diagnosis of hormone-producing adrenal cortical tumors.

Histology

The adrenal gland was zoned by Arnold in 1866 based on the pattern of the supporting reticulum (Figure 1). The outer zona glomerulosa makes up about 5–10% of the cortex. It consists of densely packed clusters of cuboidal to columnar cells with little cytoplasmic lipid and dense nuclei. Under electron microscopy

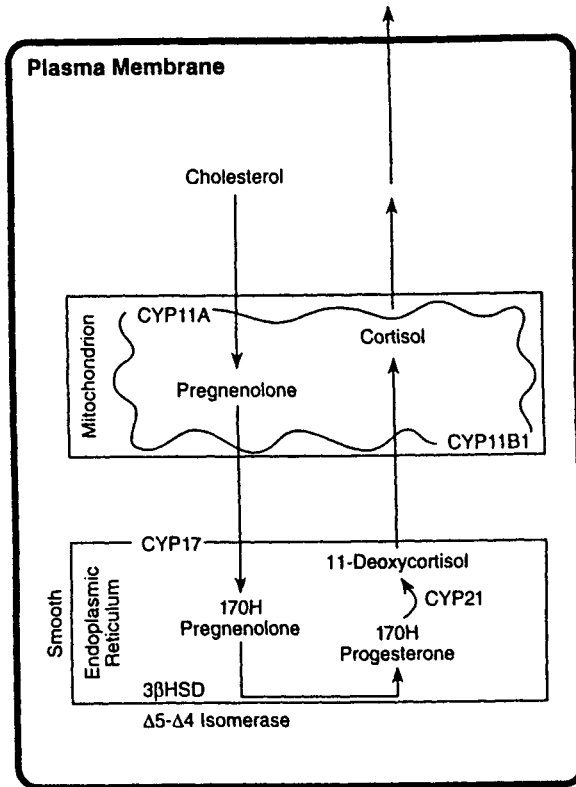

Figure 3. Biosynthesis of cortisol from cholesterol in the cytoplasm and mitochondria. The functional names for the steroidogenic enzymes are listed in Figure 4.

(EM) there are prominent Golgi, centrioles, elongate mitochondria, and a small amount of smooth endoplasmic reticulum (SER). Glomerulosa cells produce aldosterone in response to angiotensin and potassium. The zona fasciculata comprises about 70–75% of the cortex and consists of columns of polyhedral cells extending from the inner zona reticularis to the zona glomerulosa or capsule. The fasciculata cells have a central darkly staining nucleus and abundant cytoplasmic lipid-laden vacuoles. During fixation the lipids (cholesterol and cholesterol esters) are removed giving the cells a vacuolated appearance (*clear cells*). Fasciculata cells produce glucocorticoids in response to adrenocorticotrophic hormone (ACTH). The zona reticularis comprises the inner 20–25% of the cortex. These cells (*compact cells*) are tightly arranged in columns, contain densely granular cytoplasm, sparse lipid, and dark lipofuscin. On EM they possess an abundant SER and numerous liposomes and mitochondria. They produce C-19 and C-18 steroids (adrenal androgens and estrogens, respectively) and are ACTH-responsive. Func-

tionally, the zona reticularis and fasciculata form a unit, with both cell types having the capacity to produce glucocorticoids and sex steroids.

STEROID BIOSYNTHESIS

A detailed account of steroidogenesis is to be found in the Molecular and Cellular Pharmacology module. In brief, the adrenal cortex produces three major classes of hormones: glucocorticoids, mineralocorticoids, and sex steroids. Cholesterol is the common precursor to all adrenal steroids and is derived from lysosomal degradation of circulating low-density lipoproteins (LDL), hydrolysis of stored cholesterol esters, and *de novo* synthesis from acetate. Cytochrome p450 enzymes are responsible for the production of most steroid hormones from cholesterol. The p450 enzymes are located in the membranes of the SER and the mitochondrial cristae within the adrenal glands and gonads. Adrenal steroidogenesis involves a shift of steroids between SER and mitochondria. The first and last reactions involved in cortisol biosynthesis occur in the mitochondria, whereas the three intermediate steps occur in the SER (Figure 3).

Glucocorticoids

The rate-limiting step in cortisol biosynthesis is the mitochondrial conversion of cholesterol to pregnenolone (Figure 4) by the enzyme CYP11A (cholesterol desmolase, P450 scc; the "scc" stands for "side chain cleavage." The designation CYP denotes cytochrome P450, an iron-containing functional group that catalyzes steroid oxidations and that is named from its property of absorbing light maximally at the wavelength of 450 nm. The 11A denotes the fact that this enzyme belongs to the same genetic family as the 11-hydroxylases (see below). The gene for this enzyme is on chromosome 15. This enzyme catalyzes 20- and 22-hydroxylation, followed by oxidative cleavage of the C20–C22 carbon bond of cholesterol to release the C22–C27 side chain. The enzyme is regulated by ACTH and angiotensin-II (A-II). Decreased activity of this enzyme, due to a point mutation or gene deletion, results in *congenital lipoid adrenal hyperplasia*. This disorder presents as severe salt loss during the first week of life. It is fatal unless diagnosed and treated early with replacement glucocorticoid and mineralocorticoid. Males fail to masculinize the external genitalia during fetal life and are born with female external genitalia.

The remaining four steps in cortisol biosynthesis proceed as follows: pregnenolone is transferred to the SER where it undergoes 17 α -hydroxylation by the enzyme CYP17 (P450c17) to form 17-hydroxypregnenolone. The membrane-bound non-P450 3 β -hydroxysteroid dehydrogenase (3 β -HSD) converts 17-hydroxypregnenolone to 17-hydroxyprogesterone. The enzyme CYP21 (P450c21) hydroxylates 17-hydroxyprogesterone to 11-deoxycortisol, which is subsequently

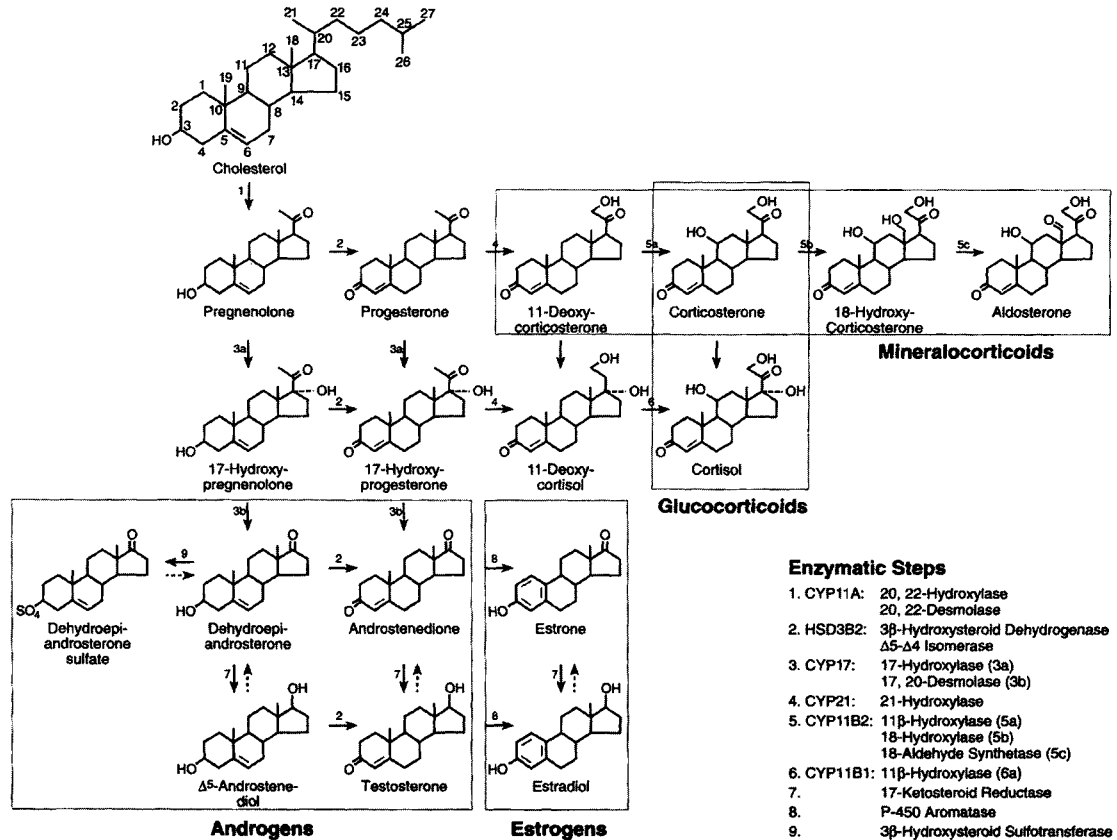

Figure 4. The steroidogenic pathway and enzymatic steps.

transferred from the SER to the mitochondria for 11-hydroxylation by CYP11B1(P450c11). This final step converts 11-deoxycortisol to cortisol.

The enzyme 3β -HSD converts pregnenolone to progesterone, 17-hydroxypregnenolone to 17-hydroxyprogesterone, DHEA to androstenedione, and androstenediol to testosterone. 3β -HSD deficiency results in increased secretion of weak androgens (DHEA) that produce modest virilization of the female fetus but are insufficient to virilize a male fetus. Consequently, female infants may have clitoromegaly and labial fusion, whereas male infants may have varying degrees of hypospadias. Older girls with 3β -HSD deficiency may present with premature pubarche, acne, amenorrhea, or hirsutism. Increased levels of 17-hydroxypregnenolone or DHEA are diagnostic of this disorder. Treatment consists of replacement doses of glucocorticoid to suppress ACTH levels and adrenal androgen production.

The conversion of pregnenolone to 17-hydroxypregnenolone, progesterone to 17-hydroxyprogesterone, 17-hydroxypregnenolone to DHEA, and 17-hydroxyprogesterone to androstenedione, is catalyzed by CYP17 (P450c17). The gene for this enzyme is located on chromosome 10. This enzyme catalyzes both 17-hydroxylation and 17,20-lyase reactions and is expressed in both the adrenal glands and gonads. 17-Hydroxylase deficiency results in decreased secretion of glucocorticoid and sex steroids and increased levels of ACTH and deoxycorticosterone (DOC). Decreased testosterone production results in an undervirilized male fetus, which in the case of severe defects may result in female external genitalia. Females appear normal at birth and may not be diagnosed until adolescence when they present with delayed puberty, primary amenorrhea, and hypertension. Cortisol production is low while corticosterone and DOC levels are elevated, which may cause hypertension and hypokalemic alkalosis. Treatment of 17-hydroxylase deficiency consists of replacement testosterone in males and replacement estrogen and progestin in females at the time of puberty.

The conversion of 11-deoxycortisol to cortisol in the glucocorticoid pathway is catalyzed by CYP11B1 (P450c11). The conversion of 11-deoxycorticosterone to corticosterone, 18-hydroxycorticosterone, and aldosterone in the mineralocorticoid pathway is catalyzed by CYP11B2 (aldosterone synthetase, corticosterone methyl oxidase). This enzyme, therefore, catalyzes 11-hydroxylation and 18-hydroxylation, and has 18-oxidase activity. The gene for this enzyme, as for CYP11B1, is on chromosome 8 and mutations in this gene give rise to two distinct clinical syndromes of 18-hydroxylase deficiency (corticosterone methyl oxidase type I, CMO-I) and 18-methyl oxidase deficiency (CMO-II).

11-Hydroxylase deficiency presents as prenatal or postnatal virilization in females due to elevated levels of ACTH and adrenal androgens. Males appear normal at birth and may not be diagnosed until they develop signs of precocious puberty. Hypertension may be present due to elevated levels of deoxycorticosterone (DOC), which has intrinsic mineralocorticoid activity. Salt loss can occur in infancy, however, when levels of DOC are relatively low and vulnerability to salt loss is

greatest, and following glucocorticoid treatment, which suppresses DOC. Diagnosis is made by elevated basal levels of plasma 11-deoxycortisol and DOC. Treatment of 11-hydroxylase deficiency consists of replacement doses of glucocorticoid.

The hydroxylation of 17-hydroxyprogesterone to 11-deoxycortisol and progesterone to 11-deoxycorticosterone is catalyzed by the enzyme 21-hydroxylase (CYP21, P450c21). The gene for CYP21 is located on chromosome 6 within the major histocompatibility antigen (HLA) complex close to the HLA-B and C4 loci. Although 2 nonallelic genes exist, only the B gene is functional; the A gene is a nonfunctional pseudogene. Mutations or deletions within the B gene result in the disorder 21-hydroxylase deficiency.

21-Hydroxylase deficiency is the most common form of congenital adrenal hyperplasia (CAH). Deficient cortisol and aldosterone production results in excessive ACTH stimulation of adrenal androgens (Figure 5). The clinical manifestations are those of excessive virilization as well as glucocorticoid and mineralocorticoid deficiency (Figure 6). The classic form of this disorder presents as virilization in female infants and hypocortisolism, with or without salt loss (simple virilizing and salt-losing forms, respectively). Male infants appear normal at birth and in the

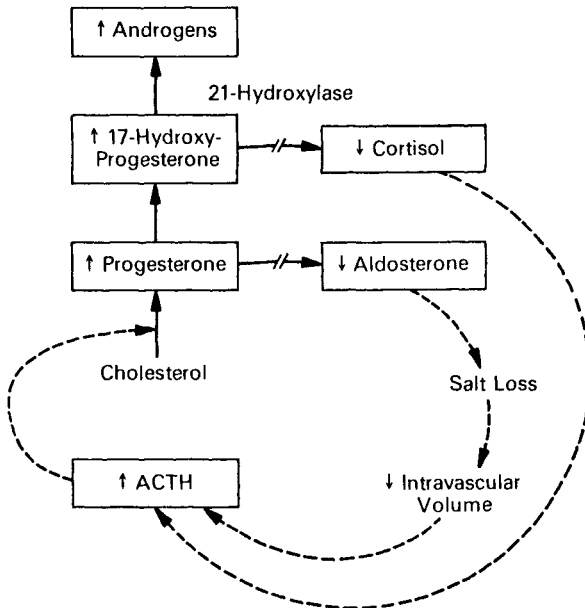

Figure 5. Dual effects of ACTH secretion in congenital adrenal hyperplasia due to 21-hydroxylase deficiency. Both cortisol deficiency, through loss of negative feedback, and aldosterone deficiency, through salt loss and hypovolemia, stimulate the secretion of ACTH in congenital adrenal hyperplasia. To simplify the presentation, only the key steroid intermediates are shown.



Figure 6. Contrasexual development in an 8-1/2-year-old girl with congenital adrenal hyperplasia.

absence of salt loss may go undiagnosed until they develop signs of precocious puberty. Increased basal levels of 17-hydroxyprogesterone in a newborn with hyponatremia and hyperkalemia is diagnostic of salt-losing 21-hydroxylase deficiency. Treatment consists of replacement doses of glucocorticoid and mineralocorticoid. A late-onset form of 21-hydroxylase deficiency can occur in women presenting with menstrual irregularities, hirsutism, acne, virilization, or infertility. Diagnosis is made by measuring 17-hydroxyprogesterone levels after ACTH stimulation.

Mineralocorticoids

Aldosterone is the major mineralocorticoid produced by the zona glomerulosa. The adrenal secretes 60–200 mcg of aldosterone daily, depending on sodium and water balance. Other steroids (11-deoxycorticosterone, 18-hydroxydeoxycorticos-

terone, corticosterone, and cortisol) also have mineralocorticoid activity which may become clinically significant in pathologic states (i.e., adrenal tumor or CAH). Among these other steroids, only cortisol exerts appreciable mineralocorticoid activity under physiologic conditions.

The synthesis of aldosterone requires steps similar to those of cortisol synthesis, except that 17-hydroxylation does not occur because of the absence of CYP17 in the zona glomerulosa. Consequently, 11-deoxycorticosterone rather than 11-deoxycortisol is produced, which is converted by CYP11B2 to corticosterone, 18-hydroxycorticosterone, and aldosterone. Most of the circulating 18-hydroxycorticosterone and aldosterone is derived from the zona glomerulosa. These two steroids are usually secreted in parallel and their levels are determined primarily by renin and angiotensin II rather than by ACTH. By contrast, most of the circulating 11-deoxycorticosterone, 18-deoxycorticosterone, and corticosterone is derived from the zona fasciculata, under the regulation of ACTH, rather than from the zona glomerulosa.

Corticosterone methyl transferase (CYP11B2, aldosterone synthetase) deficiency presents as salt-wasting in the neonate or growth impairment in children. The electrolyte profile includes hyponatremia, hyperkalemia, and hyperchloremic acidosis. Plasma renin activity is elevated. Depending upon which of the two successive oxidations at C18 is affected by mutation of the CYP11B2, two patterns of enzyme deficiency are recognized. In *CMO-I deficiency* (18-hydroxylase deficiency), the ratio of 18-hydroxycorticosterone/aldosterone is normal, whereas in *CMO-II deficiency* (18-methyloxidase deficiency), plasma 18-hydroxycorticosterone and the 18-hydroxycorticosterone/aldosterone ratio are elevated.

Adrenal Sex Steroids

The adrenal sex steroids are produced primarily in the zona reticularis and to a lesser extent in the zona fasciculata. The major synthetic enzyme is CYP17 which has both 17-hydroxylase and 17,20-lyase activity. Dehydroepiandrosterone (DHEA) is the major steroid produced, which undergoes sulfation to form DHEA-sulfate (DHEA-S). These two steroids are converted to testosterone in the adrenal gland and periphery by 3β -HSD and 17-ketosteroid reductase.

The enzyme aromatase converts testosterone to estradiol and androstenedione to estrone in the adrenal gland, gonad, and peripheral tissues. In women with intact ovarian function, the adrenal contribution to circulating estrogens is insignificant. However, in postmenopausal or agonal women, the adrenal may become the principal source of endogenous estrogen.

The onset of increased secretion of DHEA and DHEA-S by the zona reticularis is termed *adrenarche*. This process occurs between ages 5–20 years. It begins before the earliest signs of puberty and continues beyond puberty. Histologically, it is associated with development of the zona reticularis. Enzymatically, there appears to be increased activity of CYP17 leading to increased DHEA production.

Pubarche, the appearance of pubic hair, follows adrenarche and is due to increasing levels of DHEA, DHEA-S, and androstenedione, which are converted peripherally to more potent androgens (testosterone and DHT).

Premature adrenarche is the occurrence of adrenal androgen production at an age earlier than normal. It occurs more commonly in girls than in boys, and causes the early appearance of pubic hair. Additional features include axillary hair and adult body odor without significant acceleration in the rate of growth or skeletal maturation (bone age). DHEA, DHEA-S, and androstenedione levels are increased compared to prepubertal levels. Premature adrenarche is a diagnosis of exclusion, made after other causes of virilization (CAH, precocious puberty, androgen-secreting tumors, exogenous medications) have been eliminated.

PHYSIOLOGY OF ADRENAL STEROIDS

The adrenal steroids circulate in equilibrium as both free and protein-bound hormones. As free hormone is metabolized, bound hormone is liberated from its binding protein. Only the free hormone is biologically active. Binding to plasma proteins increases the amount of circulating hormone, facilitates transport of hormone in an inactive form, and increases the half-life by making the hormone resistant to degradation.

Glucocorticoids

Eighty to 90% of cortisol is bound to corticosteroid-binding globulin (CBG), while 5–10% is bound to albumin. Only about 3–10% of circulating cortisol is free and therefore able to enter cells and interact with receptor. Albumin has a higher capacity but lower affinity for cortisol than CBG. Consequently, cortisol dissociates from albumin rapidly to become available to tissues. CBG also has high affinity for cortisone, corticosterone, 11-deoxycorticosterone, progesterone, and 17-hydroxyprogesterone. Many factors can alter CBG concentration, which in turn affects the total level of plasma cortisol. Estrogens, thyroid hormone, and diabetes mellitus increase levels of CBG. Liver disease, nephrotic syndrome, hypothyroidism, multiple myeloma, and obesity decrease levels of CBG.

All steroid hormones have a common mechanism of action (Figure 7). They bind to specific intracellular receptor(s) which may be cytoplasmic or nuclear. Many steroids bind to more than one type of receptor and thereby exert more than one effect in a given tissue. The relative affinity for a receptor determines the relative bioactivity of that steroid. For example, cortisol, which binds tightly to the glucocorticoid receptor and weakly to the mineralocorticoid receptor, has primarily glucocorticoid activity and only modest mineralocorticoid activity. Binding of cortisol to the glucocorticoid receptor causes dissociation of an inhibitory protein (heat shock protein). An activated steroid–receptor complex forms which binds to specific glucocorticoid response elements (GREs) on DNA to initiate transcription

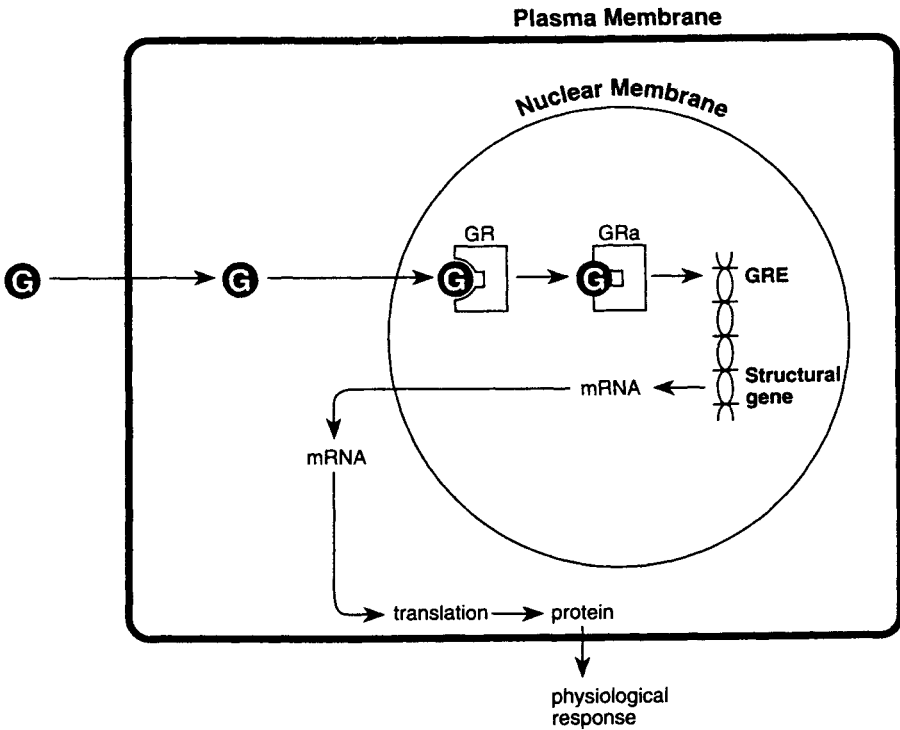

Figure 7. Schematic of glucocorticoid action. G (glucocorticoid); GR (glucocorticoid-receptor complex); GRa (activated glucocorticoid-receptor complex). The activated glucocorticoid receptor binds to a GRE (glucocorticoid receptor response element) in the regulatory region of DNA. This binding regulates expression of genes encoding proteins that are responsible for physiological responses within the cell.

of specific mRNAs. Primary cortisol resistance has been described due to mutations in the glucocorticoid receptor in patients presenting with hypercortisolism (without signs of Cushing’s syndrome) or precocious puberty, due to ACTH-induced stimulation of adrenal androgens.

Glucocorticoids have multiple actions and are essential for survival (Table 1). They regulate metabolism, immune, renal, cardiovascular, and central nervous system function, as well as growth and development. During stress, glucocorticoid levels can increase 10-fold. This increase enhances cardiac output and contractility; increases vascular resistance; mobilizes energy via lipolysis, gluconeogenesis, and proteolysis; and increases skeletal muscle contractility.

Cortisol exerts negative-feedback effects on the hypothalamus and pituitary, and may also inhibit higher cortical centers that lead to corticotropin-releasing hormone (CRH) stimulation. The amplitude and frequency of each ACTH pulse determines

Table 1. Glucocorticoid Actions

<i>Basal Levels</i>	<i>Stress Levels</i>
Negative feedback modulation of CRH, ACTH	Suppression of CRH, ACTH, ADH, endorphin, POMC
Maintenance of blood glucose and liver glycogen levels	Insulin antagonism, hyperglycemia, increased liver glycogen
Maintenance of cardiovascular function, blood pressure and muscle work capacity	Cardiovascular changes, increased blood pressure and muscle contractility
Modulation of immune function and inflammation	Immunosuppression, lympholysis, altered lymphocyte traffic, antiinflammatory effects, suppression of cytokines, lymphokines, prostaglandins, etc.
Excretion of a water load	Induction of glutamine synthetase, tryptophan oxygenase, tyrosine aminotransferase, metallothionein
Protection against moderate stress	Protection against severe stress
Unknown effects on central nervous system, behavior	Activation of central nervous system

the daily cortisol production rate. When sleep-wake cycles are regular, levels of CRH, ACTH, and cortisol peak at about 6 a.m., and fall to a nadir at about midnight. The diurnal rise in cortisol secretion, as well as increased levels during stress, result from CNS stimulation of the HPA axis that transiently overrides the negative-feedback effects of cortisol.

Corticotropin-releasing hormone (CRH) is produced in the paraventricular nucleus (PVN) of the hypothalamus and stimulates pituitary production of ACTH. It is secreted into the hypophyseal portal vessels in a pulsatile fashion and regulates the episodic secretion of ACTH and cortisol. Vasopressin synergizes with CRH and also stimulates ACTH release. Stress and other metabolic factors increase hypothalamic secretion of CRH and vasopressin.

Adrenocorticotrophic hormone (ACTH) is produced by corticotroph cells in the anterior pituitary and stimulates the adrenal cortex. CRH stimulates ACTH secretion as well as transcription of a larger molecular weight precursor, pro-opiomelanocortin (POMC), which undergoes posttranslational cleavage yielding ACTH and β -lipotropin. ACTH regulates cortisol production by binding to G protein-coupled membrane receptors on adrenocortical cells. As a consequence of receptor binding, adenylyl cyclase is activated, intracellular levels of cyclic AMP (cAMP) increase, and cAMP-dependent protein kinase phosphorylates protein(s) involved in DNA binding. Ultimately, this results in the conversion of cholesterol to pregnenolone by mechanisms that are still not well understood. ACTH also maintains adrenal size, enhances later steps in steroidogenesis, and increases cholesterol uptake from lipoproteins. When produced in excess, ACTH stimulates

melanocytes and causes hyperpigmentation as is seen in Nelson's syndrome or ectopic ACTH-secreting tumors.

Mineralocorticoids

There is no specific binding protein for aldosterone; however, approximately 65% circulates in a bound form (bound to CBG, albumin, red blood cells, and other plasma proteins). It quickly dissociates from its protein-bound state and is readily available to target tissues. Aldosterone has a plasma $t_{1/2}$ of less than 15 min and is metabolized to tetrahydroaldosterone and its conjugate, tetrahydroaldosterone glucuronide. The most potent mineralocorticoid is aldosterone, followed by 11-deoxycorticosterone, 18-oxocortisol, corticosterone, and cortisol. Mineralocorticoids act on the cortical and medullary collecting tubules of the kidney to maintain intravascular volume. They induce sodium reabsorption and potassium excretion in the cortical-collecting tubule and sodium reabsorption and hydrogen excretion in the medullary collecting tubules. Patients with mineralocorticoid deficiency develop weight loss, hypotension, hyponatremia, and hyperkalemia; those with mineralocorticoid excess develop hypertension, edema, hypokalemia, and metabolic alkalosis.

Renin is an enzyme, secreted by the juxtaglomerular apparatus of the kidney, that catalyzes the conversion of angiotensinogen to angiotensin I (A-I). The angiotensin-converting enzyme (ACE) in the endothelium of the lung, kidney, and other organs converts A-I to angiotensin-II (A-II). A-II stimulates aldosterone production by the zona glomerulosa and induces vascular smooth muscle contraction. Renin release in the kidney is regulated by the baroreceptors in the renal afferent arteriole, the macula densa, by the sympathetic nervous system, and by the negative feedback of A-II. Sodium intake and excretion, and extracellular fluid volume, are inversely related to plasma renin activity (PRA) and plasma aldosterone levels. Consequently, measurements of PRA and aldosterone are best interpreted in relation to the simultaneous 24-h urine sodium excretion, after several days of stable sodium intake.

The renin-angiotensin II-aldosterone (RAA) system plays a major role in regulating intravascular volume, sodium-potassium homeostasis, and aldosterone biosynthesis. Abnormalities of the RAA system are manifest as abnormalities in blood pressure and potassium concentration. Aldosterone exerts its biologic actions by crossing the plasma membrane of target cells and binding to cytosolic receptors. The aldosterone-receptor complex migrates to the nucleus, where it binds to DNA and initiates transcription, translation, and synthesis of proteins. The human mineralocorticoid receptor is 94% homologous to the human glucocorticoid receptor in its DNA-binding domain and 87% homologous in its steroid-binding domain. Hydrocortisone has high affinity for this receptor, hence, hypokalemic alkalosis occurs when excess glucocorticoid is present.

Increased renin secretion leads to increased activity of ACE, resulting in increased levels of A-II. A-II binds to specific adrenocortical membrane receptors which initiate hydrolysis of phosphatidylinositol-4,5-bisphosphate (PIP₂) into inositol trisphosphate (IP₃) and 1,2-diacylglycerol (DAG) through the activation of phospholipase C. Potassium is another regulator of aldosterone secretion. It directly enhances aldosterone secretion from isolated zona glomerulosa cells. Increased serum potassium augments aldosterone secretion, whereas potassium depletion diminishes aldosterone release. ACTH stimulates aldosterone production acutely, but prolonged ACTH hypersecretion leads to suppression of renin and decreased aldosterone secretion. Dopamine and atrial natriuretic hormone (ANH) are inhibitors of aldosterone secretion.

Adrenal Sex Steroids

The adrenal androgens DHEA and androstenedione are weakly bound to plasma proteins, mainly albumin. DHEA-S is tightly bound to albumin, leading to high stable levels in plasma. Dihydrotestosterone, testosterone, androstenediol, androstenediol, estradiol, and estrone are bound by sex hormone-binding globulin (SHBG). Circulating levels of SHBG are affected by age, body weight, and levels of estrogen, testosterone, and thyroid hormone.

The actions of adrenal androgens are exerted through conversion to testosterone, dihydrotestosterone, estrone and estradiol. In men, less than 2% of testosterone is from adrenal origin, whereas in females approximately 50% of androgens are of adrenal origin.

Tissue-specific regulation of steroidogenic enzymes accounts for the inability of the gonads to produce mineralocorticoids and glucocorticoids. The enzymes CYP21, CYP11B1, and CYP11B2 are not expressed in ovarian or testicular tissue.

HISTOPATHOLOGY

Adrenal pathology can be divided into three categories of disorders which may: (1) have no functional effect, (2) increase steroidogenesis, or (3) decrease steroidogenesis.

Nonfunctional Adrenal Tumors

The major nonsecretory adrenal tumors include adrenal nodules, adenomas, carcinomas, and myelolipomas. Microscopic nodular changes occur in the cortex in association with advancing age. These nests of cells enlarge to form yellow nodules (2–3 cm in diameter) which may compress the adjacent cortex and distort the capsule. These *yellow nodules* can contain areas of fibrosis, hemorrhage, and cyst formation. Pigmented *black nodules* represent a variant of yellow nodules and contain mainly zona reticularis-like cells with increased amounts of lipofuscin. These nodules are neither neoplastic nor functional. They are detected at autopsy

or incidentally on abdominal imaging and do not represent a clinically significant pathology. Their incidence increases with age and with vascular damage (i.e. diabetes, hypertension).

Adrenal adenomas are usually nonfunctional, asymptomatic, and similar to adrenal nodules. Nonfunctioning adrenal carcinomas are similar histologically to hormone-secreting adrenal carcinomas. They may secrete inactive steroid hormones which do not result in clinical symptomatology. Consequently, they are detected late and carry a poor prognosis. Myelolipomas are rare, benign adrenocortical tumors, containing adipose and bone marrow cells. They occur in older individuals and are detected as small (< 2 cm diameter), incidental, nonfunctional adrenal masses. Larger myelolipomas (> 3 cm in diameter) may present with pain, hematuria, or as an abdominal mass.

Adrenocortical Hyperfunction

Several clinical disorders result from hyperfunction of the adrenal gland. Excess glucocorticoid production (hypercortisolism) causes Cushing's syndrome; excess sex steroid production causes virilization or feminization; and excess mineralocorticoid production causes hypokalemia and alkalosis (Figure 8).

Syndrome of Glucocorticoid Excess (Cushing's Syndrome)

The syndrome initially described by Harvey Cushing in 1910 is the clinical manifestation of chronic hypercortisolemia (Figure 9). Excess glucocorticoid action leads to a catabolic state in which muscles become weak, bones become osteoporotic, skin becomes thin and atrophic resulting in striae and ulcerations, vasculature breaks down resulting in ecchymosis, immune function is impaired due to opportunistic infections, and glucose homeostasis is impaired due to enhanced gluconeogenesis and antagonism of insulin action. Findings unique to children are growth failure, premature pubarche, and delayed skeletal maturation (bone age). Hirsutism and amenorrhea may be the presenting complaints in adolescent girls. The diagnosis of Cushing's syndrome is made by confirming hypercortisolism by measuring elevated levels of urine free cortisol. Typically, there is an associated loss of diurnal cortisol variation.

Endogenous Cushing's syndrome is classified into corticotropin (ACTH)-dependent and -independent forms (80% and 20% of cases, respectively). The ACTH-dependent forms may result from Cushing's disease or paraneoplastic syndromes. Cushing's disease is the most common cause of endogenous Cushing's syndrome (approximately 70% of cases). The disorder is caused by pituitary ACTH-secreting microadenomas (< 10 mm) which are resistant to the negative feedback effects of cortisol. These tumors secrete ACTH in a pulsatile fashion (like the normal gland); however, the diurnal pattern of cortisol secretion is lost and cortisol levels are maintained at a constant high level. Paraneoplastic production of ACTH (10–15% of cases) is associated with small cell carcinoma of the lung,

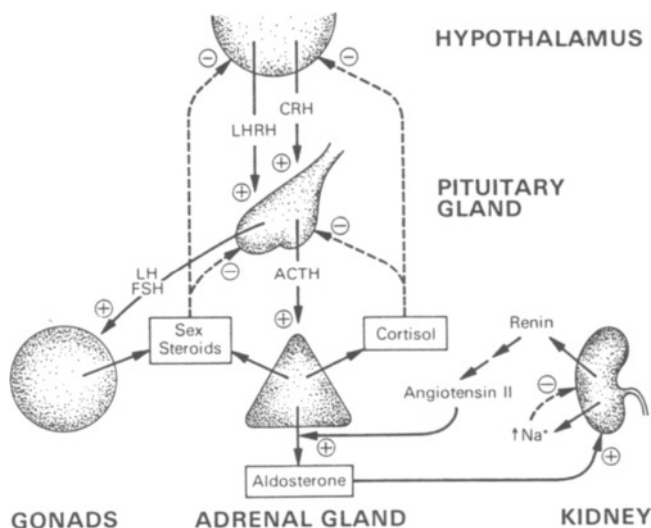

Figure 8. Endocrine systems disturbed by congenital adrenal hyperplasia due to 21-hydroxylase deficiency. Three systems are disturbed by CAH due to 21-hydroxylase deficiency: the hypothalamic–pituitary–adrenal axis [corticotropin-releasing hormone (CRH)–ACTH–cortisol], the renin–angiotensin–aldosterone axis, and the hypothalamic–pituitary–gonadal axis [luteinizing hormone-releasing hormone (LHRH); luteinizing hormone (LH); follicle-stimulating hormone (FSH); sex steroids]. Stimulatory effects are indicated by pluses, and negative-feedback effects by minuses. Na⁺ denotes sodium.

foregut tumors (thymic carcinoma, islet cell tumor, medullary carcinoma of the thyroid, bronchial carcinoid), pheochromocytoma, and tumors of the gonads, prostate, and cervix. All ACTH-dependent forms of Cushing's syndrome have high or normal plasma levels of ACTH in conjunction with hypercortisolism.

Chronic stress results in prolonged ACTH stimulation leading to adrenal hypertrophy. The weight of each adrenal may be 6–9 g. Histologically, the lipid content of clear (fasciculata) cells decreases (lipid depletion), and they take on the appearance of compact (reticularis) cells. During severe and prolonged stress, compact cells may extend from the medulla up to the zona glomerulosa or capsule.

In ACTH-dependent Cushing's syndrome the adrenal glands are hyperplastic and can weigh 6–12 g. Histologically, the cortex widens due to hyperplasia of the zona reticularis and enlargement of lipid laden clear cells of the zona fasciculata. Nests of clear cells may form micronodules around the central vein or in the periphery. Prolonged ACTH stimulation may also produce macronodular hyperplasia which appears as unilateral or bilateral nodules within hyperplastic adrenal glands. These

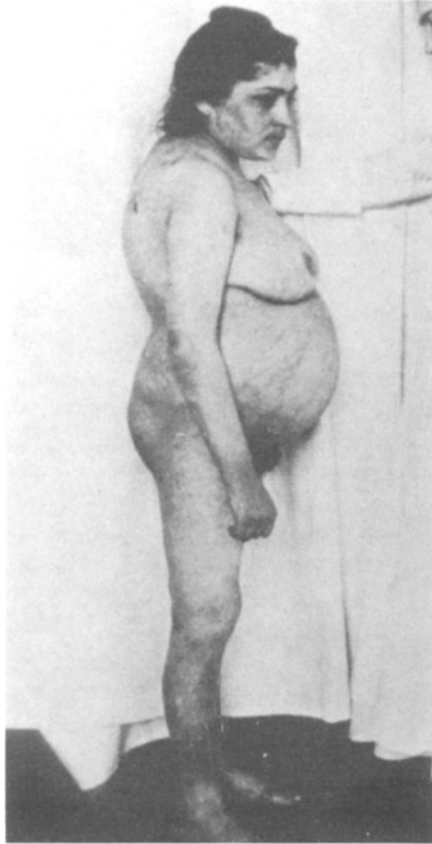

Figure 9. Clinical features of Minnie G., the first patient seen by Dr. Harvey Cushing. Note supraclavicular and dorsal fat pads, rounding of face, prominent striae and bruises, truncal obesity, and thinning of extremities, which are characteristic features of Cushing's syndrome.

macronodules have macroscopic and microscopic features similar to yellow nodules.

The most common cause of ACTH-independent Cushing's syndrome is exogenous, either iatrogenic (supraphysiologic glucocorticoid therapy) or factitious (self-induced). Histologically, the adrenal glands are small and atrophic. The endogenous ACTH-independent forms of Cushing's syndrome are of adrenal origin and include adrenal adenomas, carcinomas, and micronodular adrenal disease. In all forms, hypercortisolism is associated with low plasma levels of ACTH.

Benign cortisol-secreting adrenal adenomas comprise 10–15% of ACTH-independent Cushing's syndrome. These tumors are small (< 3 cm in diameter), usually

unilateral, and macro- and microscopically resemble adrenal nodules. Most adenomas secrete purely glucocorticoid and are comprised of clear and compact cells, although clear cells predominate. The surrounding cortex is atrophic.

Cortisol-secreting adrenal carcinomas comprise 15% of cases of ACTH-independent Cushing's syndrome in adults and 50% of cases in children. Carcinomas typically produce multiple hormones, although they are relatively inefficient in the synthesis of cortisol. Thus, by the time Cushing's syndrome is manifest, the adrenal gland may weigh over 100 g and is palpable through the abdominal wall. Cushing's syndrome associated with severe hirsutism or virilization in the female or feminization in the male is highly suggestive of adrenal carcinoma. Hypokalemic alkalosis may result from excess production of deoxycorticosterone by adrenal carcinomas. Histologically, adrenal carcinoma is associated with areas of necrosis, hemorrhage, and calcification. Satellite lesions, capsular penetration, vascular invasion, or metastasis confirm the malignant nature. Compact cells usually predominate in carcinomas, however, there is overlap with benign tumors, often making histologic diagnosis difficult.

Micronodular adrenal disease is a rare form of Cushing's syndrome occurring in children, adolescents, and young adults. It can occur in a sporadic or familial form and may be associated with other anomalies, such as multiple pigmented skin lentiginosities, cutaneous and cardiac myxomas, or other neoplasms (Carney's complex). The adrenal glands are small to minimally enlarged with a grossly nodular appearance. The nodules are < 3 mm, often pigmented with lipofuscin, and consist of compact cells. The non-nodular cortex is atrophic.

Virilizing and Feminizing Adrenal Syndromes

Increased adrenal production of androgens and estrogens can result from adrenal tumors or enzymatic defects in cortisol biosynthesis (congenital adrenal hyperplasia, CAH). Sex hormone-producing adrenal tumors are rare but do occur in children and young adults. Estrogen-producing tumors present as gynecomastia in boys (Figure 10) or premature thelarche in girls. Androgen-producing tumors present as premature adrenarche in both sexes. Girls may also develop virilization, deepening of the voice, and primary or secondary amenorrhea. Both estrogen- and androgen-producing tumors accelerate growth rate and skeletal maturation (bone age). These tumors may also secrete glucocorticoids and mineralocorticoids and therefore may simultaneously give rise to signs of hypercortisolism or hyperaldosteronism. Smaller tumors (< 70 g) are usually benign and contain compact cells. Large tumors (> 200 g) generally have more cellular atypia, necrosis, hemorrhage, and calcification. However, overlap between benign and malignant sex-hormone producing tumors exists in regard to cellular and nuclear pleomorphism.

CAH is a family of disorders resulting from defects in cortisol biosynthesis. The adrenal glands are enlarged due to ACTH hypersecretion which results from the loss of cortisol feedback on the hypothalamus and pituitary. In all forms of CAH,

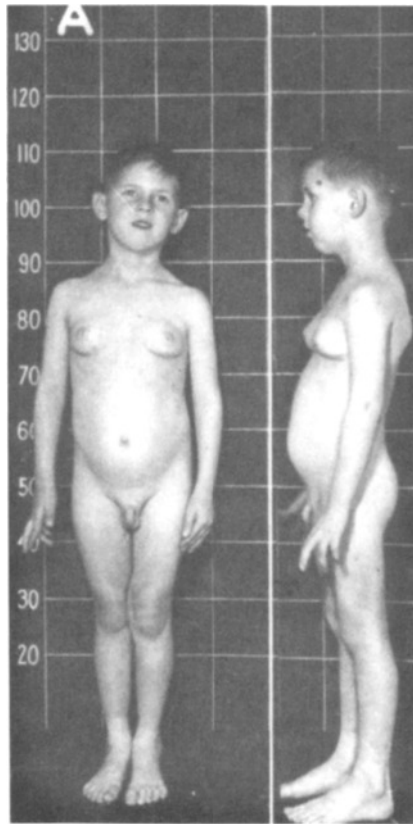

Figure 10. Contrasexual development in a 5-1/2-year-old boy with an estrogen producing adrenocortical adenoma.

the adrenal glands are hyperplastic with a widened convoluted cortex comprised of compact cells. Hyperplasia of the zona glomerulosa is frequently seen in patients with coexisting mineralocorticoid deficiency.

A rare form of CAH resulting from deficiency of the enzyme 20,22-desmolase prevents mobilization of cholesterol for steroid synthesis. Histologically, cortical hyperplasia with clear, lipid laden cells is observed, hence the term *lipoid adrenal hyperplasia*. Deficiency of the enzyme 21-hydroxylase, 11-hydroxylase, or 3β -hydroxysteroid dehydrogenase (3β -HSD) results in virilization of a female fetus. Deficiency of the enzyme 17-hydroxylase, 20,22-desmolase, or 3β -HSD results in undervirilization of a male fetus.

Syndromes of Mineralocorticoid Excess

Increased secretion of aldosterone may result from increased adrenal production (primary hyperaldosteronism) or increased activity of the renin–angiotensin system

(secondary hyperaldosteronism). Signs and symptoms of hyperaldosteronism include nocturia, polyuria, weakness, paresthesias and tetany (due to hypokalemia), alkalosis, hypernatremia, and hypertension.

Primary hyperaldosteronism results from aldosterone-producing adrenal adenomas and carcinomas, idiopathic hyperaldosteronism, and glucocorticoid-suppressible hyperaldosteronism. These disorders present with hypokalemic alkalosis, low plasma renin activity (PRA), and high aldosterone levels. Aldosterone-producing adenomas are usually small (< 10 g), unilateral, solitary, with peak occurrence in the third to fourth decade of life. They have a characteristic golden-yellow cut surface and are comprised of large and small clear cells, compact cells, and glomerulosa cells. The uninvolved cortex is generally hypoplastic; however, occasionally the zona glomerulosa may be hyperplastic. Aldosterone-producing adenomas function autonomously and are only minimally affected by angiotensin-II. They are unresponsive to the suppressive effects of dopamine and atrial natriuretic hormone; however, hypokalemia may suppress aldosterone production. Any patient presenting with hypertension, hypokalemic alkalosis, low PRA, and borderline or high plasma aldosterone levels should be evaluated for autonomous overproduction of aldosterone. Surgical removal of the adenoma corrects the hyperaldosteronism.

Malignant aldosterone-producing neoplasms are rare and similar in size and characteristics to other adrenocortical carcinomas. The clinical features of these neoplasms resemble those associated with aldosterone-producing adenomas.

Bilateral diffuse hyperplasia (idiopathic hyperaldosteronism) is responsible for mineralocorticoid excess in 70–80% of patients with primary hyperaldosteronism. The adrenal glands are normal to moderately enlarged and the cortex appears micronodular (although macronodules may be present). In some patients with bilateral hyperplasia, the hyperaldosteronism is dependent on ACTH stimulation and is termed *glucocorticoid-suppressible hyperaldosteronism*. This is a rare, autosomal dominant cause of low renin hypertension. Basal levels of 18-hydroxycortisol and 18-oxocortisol are also increased, indicating that corticosterone methyl oxidase (CMO) activity is present in the zona fasciculata. Both aldosterone and 18-oxocortisol levels increase after ACTH stimulation. The unique clinical features of this form of hyperaldosteronism are rapid suppression of aldosterone by dexamethasone (in 24–48 h) and sustained increase in aldosterone after ACTH stimulation. The molecular mechanism of this disorder is an abnormal chimeric 11-hydroxylase gene, produced by an unequal crossover between the two 11-hydroxylase genes, CYP11B1 and CYP11B2. This chimeric gene has the regulatory sequences from the CYP11B1 gene, leading to its expression in the zona fasciculata, and the structural sequences from the CYP11B2 gene, leading to its ability to synthesize aldosterone. Thus, patients with glucocorticoid-suppressible hyperaldosteronism have an abnormal 11-hydroxylase gene that leads to aldosterone production by the zona fasciculata.

The syndrome of apparent mineralocorticoid excess presents with hypernatremia, hypokalemic alkalosis, and hypertension, despite low plasma renin and

aldosterone levels. Oxidation of cortisol to cortisone is impaired due to decreased activity of 11β -hydroxysteroid dehydrogenase. This results in accumulation of cortisol in renal tubule cells and increased occupancy of the mineralocorticoid receptor by cortisol. The syndrome of apparent mineralocorticoid excess also occurs following ingestion of licorice and glycyrrhizic acid (or its metabolite, glycyrrhetic acid).

In secondary hyperaldosteronism, plasma renin activity (PRA) is increased. A variety of disorders of the kidney, liver, heart, and gastrointestinal tract may lead to hyperreninemia, hyperaldosteronism, and hypokalemia. Blood pressure may be high, normal, or low. The mechanism responsible for increased renin secretion is reduced effective blood volume with compensatory activation of the renin-angiotensin-II system. Secondary hyperaldosteronism with hypertension is present in cases of renovascular hypertension (renal artery stenosis), renin-secreting tumors, malignant hypertension, and chronic renal disease. Secondary hyperaldosteronism with normal or low blood pressure is associated with renal tubular acidosis, cardiac failure, hepatic cirrhosis, gastrointestinal disorders, renal tubulopathies, and chronic renal disease.

Bartter's syndrome is a disorder of renal tubular transport presenting in childhood with failure to thrive, weakness, salt-craving, polyuria, and polydipsia. Hypokalemic alkalosis, hypochloremia, normal or low serum magnesium, and increased PRA and aldosterone levels are observed. Blood pressure is normal. A defect in chloride transport in the thick ascending loop of Henle is felt to be the primary defect in Bartter's syndrome. Overproduction of prostaglandins occurs secondarily to the hypokalemia.

Adrenocortical Hypofunction

Adrenal Insufficiency

The syndrome of adrenal insufficiency is the clinical manifestation of deficient production of cortisol. Symptoms of adrenal insufficiency include muscle, joint, and abdominal pain, weakness, fatigue, anorexia, nausea, diarrhea, and postural hypotension. Signs include fever, weight loss, hypotension, and altered sensorium. Cardiac output and vascular tone is reduced. This stimulates vasopressin secretion resulting in water retention and hyponatremia.

Adrenal insufficiency may be primary (Addison's disease) due to destruction of the adrenal gland or secondary due to ACTH deficiency (Figure 11). Primary adrenal insufficiency results in both mineralocorticoid and glucocorticoid deficiency. Hyperpigmentation of the extensor surfaces, skin creases, scars, and gingiva may occur due to increased ACTH and β -lipotropin secretion. Secondary adrenal insufficiency results only in glucocorticoid deficiency, without associated hyperpigmentation.

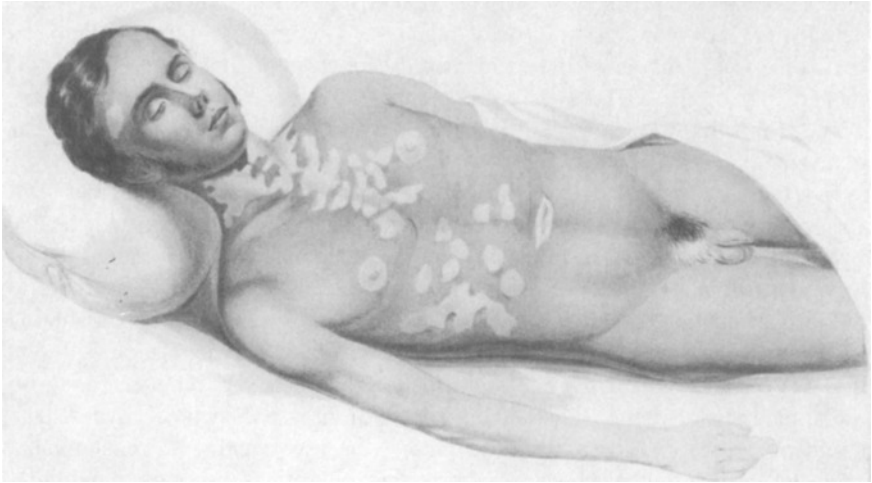

Figure 11. Clinical features of the patient described by Dr. Thomas Addison with chronic adrenal insufficiency. Note vitiligo on trunk in conjunction with generalized hyperpigmentation.

The two major causes of primary adrenal insufficiency are tuberculous and autoimmune adrenalitis. Tuberculous adrenalitis destroys the normal cellular architecture and results in caseous necrosis, lymphocytic and giant cell infiltrates, and calcifications throughout the adrenal gland. Tuberculous bacilli may be detected in 50% of cases. The adrenals are enlarged (> 20 g) and may become adherent to surrounding structures.

In autoimmune adrenalitis the cortex thins and the remaining cortical cells resemble zona reticularis cells. A diffuse mononuclear cell infiltrate with fibrosis may be present. Many cases of primary adrenal insufficiency are associated with the polyglandular deficiency syndrome. This syndrome is autoimmune and associated with other disorders of known autoimmune etiology, such as vitiligo, alopecia areata, celiac disease, autoimmune thyroiditis, and mucocutaneous candidiasis. There are two forms of polyglandular deficiency syndrome (Table 2). Type 1 is autosomal recessive and occurs in childhood. The most common manifestations are adrenal insufficiency, hypoparathyroidism, and mucocutaneous candidiasis, although hypogonadism, pernicious anemia, chronic active hepatitis, and alopecia may develop. Type 2 occurs in young adults. Susceptibility to Type 2 seems to be inherited as an autosomal dominant in linkage disequilibrium with the HLA-B loci on chromosome 6 (HLA-B8, DR3). Adrenal insufficiency, thyroid disease, and diabetes mellitus are the most common manifestations.

Table 2. Polyglandular Deficiency Syndrome

Type I	Type II
Adrenal insufficiency	Adrenal insufficiency
Hypoparathyroidism	Insulin-dependent diabetes mellitus
Primary hypothyroidism	Primary hypothyroidism
Primary hypogonadism	Hyperthyroidism
Mucocutaneous candidiasis	Primary hypogonadism
Chronic active hepatitis	Myasthenia gravis
Malabsorption	Celiac disease
Vitiligo	Vitiligo
Pernicious anemia	Pernicious anemia
Alopecia	Alopecia
Siblings affected	Multiple generations affected
No HLA association	HLA-B8, DR-3 association
Onset in infancy/youth	Peak incidence 20–60 yrs
Autosomal recessive	Autosomal dominant

Adrenal hemorrhage (Waterhouse–Friderichsen syndrome), metastatic cancer, fungal infections, sarcoidosis, amyloidosis, congenital adrenal hypoplasia, CAH, Wolman’s disease, adrenoleukodystrophy (ALD or Brown–Schilder’s disease), adrenomyeloneuropathy (sudanophilic leukodystrophy), acquired immunodeficiency syndrome (AIDS), and ACTH-unresponsive syndrome are additional causes of primary adrenal insufficiency.

Two distinct forms of congenital adrenal hypoplasia occur in the newborn: cytomegalic and anencephalic. In the cytomegalic form, the adrenals are small (< 1 g) and consist of large compact eosinophilic cells. Neonates with this disorder present with vomiting, poor feeding, hypoglycemia, cyanosis, and hypotension. It is fatal unless diagnosed promptly and treated with replacement steroids (glucocorticoid and mineralocorticoid). Inheritance is autosomal recessive or X-linked. In the anencephalic form, the adrenals are small, consisting only of an adult cortex. This disorder results from central, hypothalamic, or pituitary dysfunction and is therefore a form of secondary adrenal insufficiency.

Adrenoleukodystrophy (ALD) is a fatal peroxisomal disorder associated with progressive congenital demyelination and adrenal insufficiency. Very long chain fatty acids levels are increased in the serum and cytoplasmic inclusions are found on microscopic examination of the adrenal cortex. The inheritance ALD is X-linked recessive.

Necrotizing adrenalitis and primary adrenal insufficiency are associated with AIDS. Whether this is a direct effect of the virus on the adrenal or the result of secondary infections (*Mycobacterium* sp. or cytomegalovirus) is unknown.

A primary defect in the ACTH receptor results in the ACTH-unresponsive syndrome (ACTH resistance), which is characterized by glucocorticoid and mineralocorticoid deficiency, and increased levels of plasma ACTH and hyperpigmentation. Achalasia and alacrima may also occur.

The diagnosis of primary adrenal insufficiency is confirmed by a subnormal cortisol response to synthetic ACTH (Cortrosyn). Treatment consists of glucocorticoid and mineralocorticoid replacement therapy. During times of stress, the dose of glucocorticoid should be increased two- to threefold to prevent adrenal crisis.

Secondary adrenal insufficiency can result following exogenous glucocorticoid or ACTH administration, correction of endogenous glucocorticoid hypersecretion, or from abnormalities of the hypothalamus or pituitary leading to ACTH deficiency.

Supraphysiologic doses of glucocorticoids given over time will suppress hypothalamic CRH production and the pituitary responsiveness to CRH. The degree of suppression is dependent upon glucocorticoid dose, schedule, and duration of administration. Adrenal suppression is likely to occur as the dose of hydrocortisone (or its equivalent) exceeds 20 mg/m²/day; with divided dose schedules (as opposed to daily or alternate-day schedules); and with treatment duration greater than 14 days.

Intracranial tumors (craniopharyngioma, pituitary adenoma, metastatic disease), sarcoidosis, infections, hemochromatosis, radiation, congenital panhypopituitarism, and developmental anomalies (such as septo-optic dysplasia) can result in ACTH deficiency and secondary adrenal insufficiency. Histologically, the adrenal glands are small and atrophic. The cortex is thin and comprised of a normal zona glomerulosa, a diminished zona fasciculata, and an absent zona reticularis.

Syndromes of Mineralocorticoid Deficiency

The syndrome of hypoaldosteronism results in hyperkalemia, metabolic acidosis, hyponatremia, decreased effective blood volume, and orthostatic hypotension. It may result from primary adrenal dysfunction, defective stimulation of aldosterone production, or target tissue unresponsiveness to aldosterone. Primary defects in aldosterone production include all the causes of primary adrenal insufficiency [congenital adrenal hypoplasia, CAH, adrenoleukodystrophy, adrenomyeloneuropathy, and corticosterone methyl oxidase type I or II (CMO-I or CMO-II) deficiency]. Removal of a mineralocorticoid-secreting tumor or discontinuation of an exogenous mineralocorticoid is followed by a transient period of hypoaldosteronism and hyperreninemia lasting up to 6 weeks.

Defective stimulation of aldosterone production includes syndromes of congenital and acquired hyporeninemic hypoaldosteronism and drug-induced hyporeninemia (secondary to β -adrenergic blockers, prostaglandin synthetase inhibitors, calcium channel blockers). Decreased conversion of angiotensin I to angiotensin II by ACE inhibitors causes hyperreninemic hypoaldosteronism.

Impaired aldosterone action includes the syndrome of aldosterone resistance or pseudohypoaldosteronism (characterized by elevated levels of plasma aldosterone and clinical manifestations of hypoaldosteronism) and sodium-wasting states due to excessive treatment with mineralocorticoid antagonists.

SUMMARY

During development, the adrenal cortex differentiates into the zona fasciculata, glomerulosa, and reticularis which produce glucocorticoids, mineralocorticoids, and sex steroids, respectively. The rate-limiting step in cortisol biosynthesis is the conversion of cholesterol of pregnenolone by the first enzyme in the pathway, CYP11A (cholesterol desmolase). The remaining four steps in cortisol biosynthesis are catalyzed by the enzymes CYP17, 3 β -HSD, CYP11B1, and CYP21. Deficiency of any of these five enzymes results in the family of disorders known as congenital adrenal hyperplasia (CAH).

Aldosterone is produced by the zona glomerulosa. Its synthesis requires steps similar to those for cortisol except for 17-hydroxylation. Mutations in the gene required for aldosterone synthesis (CYP11B2) produce two types of enzyme deficiencies: CMO-I (18-hydroxylase deficiency) and CMO-II (18-methyloxidase deficiency).

Adrenal sex steroids (DHEA and DHEA-s) are produced by the zona reticularis. Histological development of the zona reticularis coincides with the clinical onset of adrenarche, occurring around age 5–7 years, before the earliest signs of puberty. Early maturation of the zona reticularis results in the syndrome of premature adrenarche.

All steroid hormones share a common mechanism of action and bind to specific intra-cellular receptors. Glucocorticoids have multiple effects on growth, development, intermediary metabolism, cardiovascular, central nervous system, and immune function. Mineralocorticoids maintain intravascular volume and sodium and potassium homeostasis through the renin–angiotensin–aldosterone system. The actions of adrenal androgens are exerted through their conversion to testosterone, dihydrotestosterone, and estrogens.

Pathology of the adrenal produces three categories of clinical disorders. Those that are nonfunctional, arising from nonhormonal-producing tumors; those that increase steroidogenesis, which include disorders of glucocorticoid excess (Cushings syndrome); androgen and estrogen excess (virilizing and feminizing syndromes); and mineralocorticoid excess (hyperaldosteronism); and, those that decrease steroidogenesis, which include syndromes of glucocorticoid and mineralocorticoid deficiency.

RECOMMENDED READINGS

- DeGroot, L.D., Besser, G.M., Cahil, G.M., Jr., Marshall, J.C., Nelson, D.H., Odell, W.D., Potts, J.T., Jr., Rubenstein, A.H., & Steinberger, E. (Eds.) (1989). *Endocrinology*, Vol. 2, pp. 1543–1713. Saunders, Philadelphia.
- James, V.H.T. (1992). *The Adrenal Gland*, 2nd ed., Raven, New York.
- Loriaux, D.L., & Cutler, G.B., Jr. (1986). In: *Clinical Endocrinology*, pp. 167–238. Wiley, New York.
- Mesiano, S., & Jaffe, R.B. (1997). Developmental and functional biology of the primate fetal adrenal cortex. *Endocr. Rev.* 18, 378–403.
- Orth, D.N., Kovacs, W.J., & DeBold, C.R. (1992). In: *Williams Textbook of Endocrinology* (Wilson, J.D., & Foster, D.W., Eds.), pp. 489–619. Saunders, Philadelphia.
- Pescovitz, O.H., Cutler, G.B., Jr., & Loriaux, D.L. (1990). In: *Principles and Practice of Endocrinology and Metabolism* (Becker, K.L., et al., Eds.), pp. 579–591. Lippincott, Philadelphia.
- Rittmaster, R.S., & Cutler, G.B., Jr. (1990). In: *Principles and Practice of Endocrinology and Metabolism* (Becker, K.L., Bilezikian, J.P., Bremner, W.J., Hung, W., Kahn, C.R., Loriaux, D.L., Rebar, R.Q., Robertson, G.L., & Wartofsky, L., Eds.), pp. 572–579. Lippincott, Philadelphia.
- Vinson, G.T., Whitehouse, B., & Hinson, J. (1992). *The Adrenal Cortex*. Prentice Hall, Englewood Cliffs, NJ.
- Vinson, G.T., & Anderson, D.C. (1996). *Adrenal Glands, Vascular System and Hypertension*. Blackwell, Oxford.

Chapter 10

Steroid Hormone and Related Receptors

HANSJÖRG KELLER and WALTER WAHLI

Introduction	256
Steroid Hormone Receptors are Members of a Superfamily of Nuclear Receptors	258
Regulatory Mechanisms of Receptor Activity	266
Ligand Binding	266
Ligand-Independent Regulatory Mechanisms	268
Inhibition of Receptor Activity by Antihormones	269
Nuclear Hormone Receptors Bind to Short DNA Sequences within Target Gene Promoters Called Hormone Response Elements	269
Positive Hormone Response Elements	269
Negative Hormone Response Elements	274
Regulation of Gene Transcription by Nuclear Hormone Receptors	275
Signaling Crosstalk between Different Nuclear Hormone Receptors and between Receptors and Other Transcription Factors	278
Dimerization of Nuclear Hormone Receptors	278
Interaction of Nuclear Hormone Receptor Dimers	280
Interaction of Nuclear Hormone Receptors with Other Transcription Factors in the Absence of DNA Binding	281

Principles of Medical Biology, Volume 10A
Molecular and Cellular Endocrinology, pages 255–296.

Copyright © 1997 by JAI Press Inc.

All rights of reproduction in any form reserved.

ISBN: 1-55938-815-3

Nuclear Hormone Receptor Functions in Development and Homeostasis	281
Mineralocorticoid Receptor	282
Glucocorticoid Receptor	282
Vitamin D Receptor	283
Thyroid Hormone Receptors	283
Sex Steroid Hormone Receptors	284
Retinoid Receptors	286
Orphan Receptors and Insect Nuclear Receptors	288
Diseases Caused by Nuclear Hormone Receptor Abnormalities	291
Conclusions and Perspectives	293

INTRODUCTION

Cell-to-cell communication over long distances is accomplished by specific signaling molecules termed hormones. They are secreted by glandular cells and elicit distinct responses in target cells, which contain the appropriate hormone receptors. According to their chemical nature and their mode of signal transduction, hormones are broadly classified into lipophilic and hydrophilic hormones. Lipophilic hormones, such as the classical steroid hormones, are able to cross the plasma membrane to reach their cytoplasmic or nuclear receptors. Hydrophilic hormones, such as polypeptide hormones, catecholamines, and eicosanoids, are unable to traverse the cell membrane, and thus bind to membrane receptors at the cell surface (Figure 1). Due to the different modes of signal transduction, the speed of action of the two systems can be very different. Nuclear hormone receptors are ligand-dependent transcription factors that directly regulate gene expression. Since this usually implicates protein synthesis, nuclear hormone receptor responses are delayed and vary from several minutes to hours. In contrast, the primary effect of membrane hormone receptors is the generation of second messengers that mediate changes in the activity of existing proteins such as ion channels, enzymes, or transcription factors. Therefore, membrane hormone receptors elicit two types of responses: an instantaneous response within seconds or fractions of a second, resulting from the change in activity, for example, of ion channels; and a slow response that involves gene expression by regulation of transcription factor activity.

This chapter focuses on the structure and function of steroid hormone and related receptors. It outlines the identification and cloning of steroid hormone receptors and describes how the discovery of a common structural organization has led to the cloning of many other related receptors. Individual receptor functions are examined with emphasis on how receptors are activated or inhibited, how receptors bind to short DNA sequences called hormone response elements, and how the DNA-receptor complexes ultimately regulate gene transcription. We will also discuss the diverse ways of signaling cross-talk that arise from interactions between the different nuclear hormone receptors and also between nuclear receptors and other transcription factors. Then, many known physiological functions of cloned nuclear

A

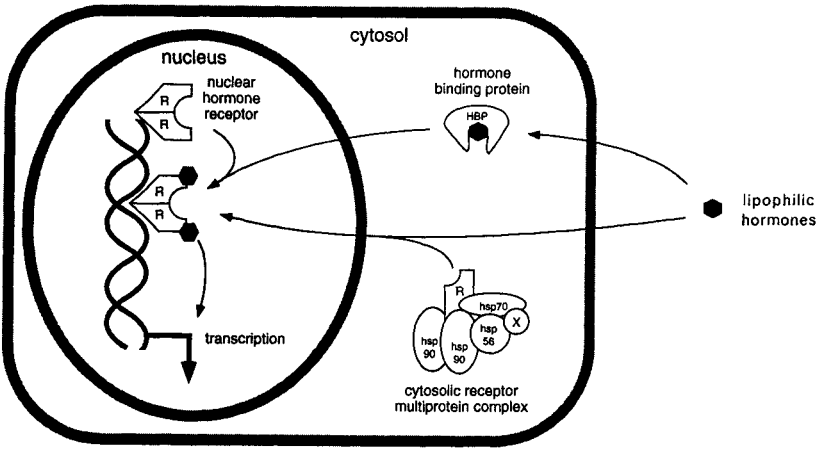

B

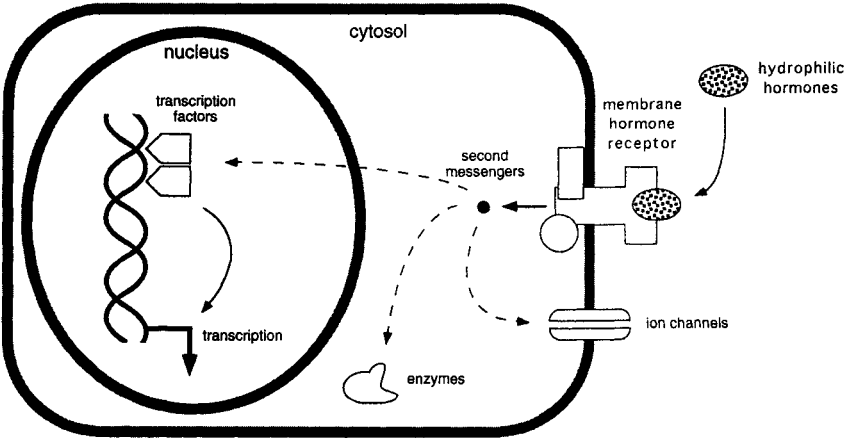

Figure 1. Major signal transduction pathways of lipophilic and hydrophilic hormones. **(A)** Lipophilic hormones such as steroid, thyroid, and retinoid hormones bind to specific nuclear receptors (R) that regulate gene transcription often in the form of dimers. As an exception, the hormone-free glucocorticoid receptor is mainly found in the cytoplasm as part of a multiprotein complex, including also several heat-shock proteins (hsp's) and other noncharacterized proteins (X). Hormone binding induces the dissociation of this complex and allows the dimerization and nuclear translocation of the receptor. Because of their poor solubility in aqueous environments such as cytoplasm and blood, lipophilic hormones are transported and stored by different hormone binding proteins (HBP). **(B)** In contrast to lipophilic hormones, hydrophilic hormones do not cross the plasma membrane and bind to membrane-bound receptors. The signal is then transmitted via second messengers which induce modifications of existing proteins such as via phosphorylation and thus, trigger a variety of responses.

hormone receptors are summarized, and the last section gives examples of human genetic diseases that are associated with nuclear hormone receptor abnormalities.

STEROID HORMONE RECEPTORS ARE MEMBERS OF A SUPERFAMILY OF NUCLEAR RECEPTORS

The profound effects of steroid and thyroid hormones on development and homeostasis in animals and humans have been known since the beginning of this century. The first confirmation of the concept that specific high-affinity receptors bind hormones and mediate their actions was made possible in the early 1960s by the availability of radioactively labeled estrogen. It was observed that [³H]estradiol, injected into rats, was specifically retained by estrogen responsive tissues such as the uterus or vagina, whereas the [³H]estradiol concentration was much lower in nonresponsive tissues. Binding experiments using crude cell extracts indicated a putative receptor dissociation constant of 1 nM (Jensen and DeSombre, 1972), which is compatible with estradiol plasma concentrations ranging between 0.2 and 3 nM. Fractionation of cell extracts by centrifugation revealed that the major part of radioactive estrogen was found in the nuclei and not in the cytosol, suggesting a role for steroid hormone receptors in gene regulation.

Purification of steroid hormone receptors, which generally account for only a minute fraction of total cellular protein, in the order of 10^3 to 10^5 molecules per cell, was facilitated by the advent of protein affinity chromatography using either specific antibodies against receptors or synthetic hormone derivatives coupled to column resins. This led to the purification of receptors for estrogen, glucocorticoids, and progesterone in the early 1980s. In parallel to protein purification, advances were also made in the study of receptor function. It was observed that female sex steroid hormones had effects on different metabolic processes, presumably through enzyme modification or increased synthesis. A fast and strong induction of RNA synthesis was also consistently observed in responsive tissues.

Thus, much attention was focused on the hypothesis that stimulation of gene expression is an important function of steroid and thyroid hormone receptor action. Support for this hypothesis was provided by two key experiments: the induction of amphibian metamorphosis by thyroid hormone, a process thought to be caused by differential gene expression (Gilbert and Frieden, 1981), and the demonstration that the steroid hormone ecdysone, a hormone responsible for molting and metamorphosis of insects, induces gene transcription through the induction of polytene chromosome puffs (Clever and Karlson, 1960). Significant advances in the understanding of how the transcription of target genes is regulated by steroid hormones resulted mainly from studies of a few model systems: the induction of the egg-white protein ovalbumin by progesterone in the chicken oviduct, the induction of the egg-yolk protein vitellogenin by estrogen in the liver of oviparous vertebrates, and the activation of the mouse mammary tumor virus (MMTV) by glucocorticoids. The development of recombinant DNA techniques and the availability of purified

receptors allowed identification of hormone response elements (HRE) in the promoters of target genes. Thus, the model emerged that steroid hormone receptors are transcription factors, which, upon hormone activation, bind to specific short DNA sequences in target gene promoters and induce transcription of these genes (Yamamoto, 1985).

The first steroid hormone receptors were cloned in the mid-1980s. Comparison of their amino acid sequences, and functional analyses revealed a common structural and functional organization (Evans, 1988; Green and Chambon, 1988). Four main functional regions of the receptors are distinguished (Figure 2): (1) the N-terminal A and B domains that are involved in the activation of gene transcription; (2) the C domain that mediates DNA-binding; (3) the D domain that links the DNA-binding domain with the ligand-binding domain and, in some cases, also

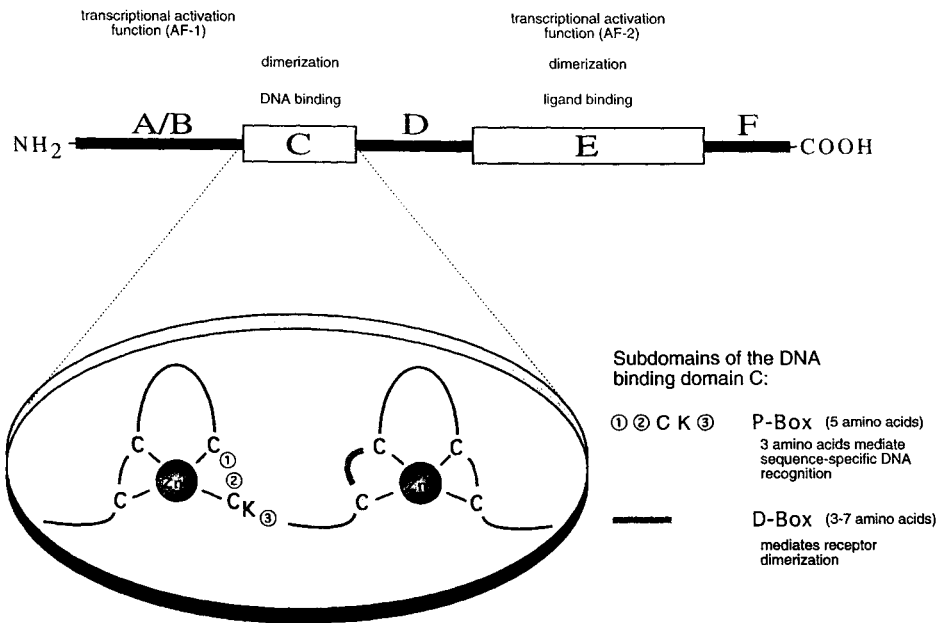

Figure 2. Protein domain structure of nuclear hormone receptors. Six major domains are distinguished from A to F. Some functions that have been attributed to individual domains are indicated above the schematic representation of the receptor. The DNA-binding domain C is shown in a blowup below. It is composed of two polypeptide loops that each bind a zinc atom via four cysteines. These structures are referred to as zinc fingers. Two subdomains of domain C are also indicated: the P-box and the D-box. The amino acids at the indicated three positions in the P-box (1–3) make the discriminatory contact with particular nucleotides of the hormone response elements. Thus, the nature of these three amino acids determines the recognized nucleotide sequence. The other subdomain (D-box) is involved in receptor dimerization in addition to dimerization performed by domain E.

Table 1. Cloned Nuclear Hormone Receptors with Their Common Abbreviations and References

Abbreviations	Names	References
Ad4BP	Ad4 binding protein (= ELP)	1
AR	Androgen receptor	2, 3, 4, 5
ARP-1	apoA1 regulatory protein 1 (= COUP-TFII)	6
BD73	proper name (= RevErb β)	7
COUP-TF	Chicken ovalbumin upstream promoter-transcription factor (= ear-3 and svp44)	8
COUP-TFII	= ARP-1	9
dax-1	DSS-AHC critical region on the X chromosome, gene 1	10
DHR3	<i>Drosophila</i> hormone receptor 3	11
DHR39	<i>Drosophila</i> hormone receptor 39 (= FTZ-F1 β)	12
E75	<i>Drosophila</i> E75 gene product	13
E78	<i>Drosophila</i> E78 gene product	14
ear-1	erbA-related gene 1 product (= Rev-Erb α)	15
ear-2	erbA-related gene 2 product	16
ear-3	erbA-related gene 2 product (= COUP-TF)	16
EcR	Ecdysone receptor	17
ELP	Embryonal long-terminal repeat-binding protein (= SF-1 and Ad4BP)	18
egon	<i>Drosophila</i> embryonic-gonad gene product	19
ER	Estrogen receptor	20, 21
ERR1	Estrogen receptor related receptor 1	22
ERR2	Estrogen receptor related receptor 2	22
FTZ-F1	Fushi tarazu gene transacting factor 1	23
FTZ-F1 β	(= DHR39)	24
GCNF	Germ cell nuclear factor	25
GR	Glucocorticoid receptor	26
HNF-4	Hepatocyte nuclear factor 4	27
kni	<i>Drosophila</i> knirps gene product	28
knrl	<i>Drosophila</i> knirps-related gene product	19
LRH-1	Liver receptor homologous protein 1	29
MB67	Proper name	30
MR	Mineralocorticoid receptor	31
NGFI-B	Nerve growth factor induced gene B product (= nur77 and TR3)	32
nur77	Immediate early gene nur/77 (= NGFI-B)	33
NURR1	Nur-related factor 1 (= RNR-1)	34
ONR1	<i>Xenopus</i> orphan nuclear receptor 1	35
PHR-1	Pancreas hormone receptor (= LRH-1)	36
PPAR α , β , γ	Peroxisome proliferator-activated receptor	37, 38

(continued)

Table 1. Continued

Abbreviations	Names	References
PR	Progesterone receptor	39, 40
RAR α , β , γ	Retinoic acid receptor	41, 42, 43
Rev-Erb α , β	erbA related protein (= ear-1 and RVR)	44, 45, 46
RNR-1	Regenerating liver nuclear receptor(= NURR1)	47
ROR α	RAR-related orphan receptor (= RZR)	48
RVR	Rev-Erb α related receptor (= Rev-Erb β)	49
RXR α , β , γ	Retinoid X receptor	50
RZR α , β	New subfamily ("Z") of potential retinoic acid binding receptors (= ROR)	36, 51
SF-1	Steroidogenic factor 1 (= ELP)	52
svp	<i>Drosophila</i> seven-up gene product	53
svp44	svp-like protein 44 (= COUP-TF)	54
svp46	svp-like protein 46	54
tll	<i>Drosophila</i> tailless gene product	55
Tlx	Related to tll	56
TR α , β	Thyroid hormone receptor	57, 58, 59
TR2	Testis receptor 2	60
TR3	Testis receptor 3 (= NGFI-B)	61
TR4	Testis receptor 4	62
UR	Ubiquitous receptor	63
usp	<i>Drosophila</i> ultraspiracle gene product	64, 65, 66
VDR	Vitamin D receptor	67

- Honda, S., Morohashi, K., Nomura, M., Takeya, H., Kitajima, M., & Omura, T. (1993). *J. Biol. Chem.* 268, 7494-7502.
- Chang, C., Kokontsis, J., & Liao, S. (1988). *Science* 240, 324-326.
- Tilley, W.D., Marcellini, M., Wilson, J.D., & McPhaul, M.J. (1989). *Proc. Natl. Acad. Sci. USA* 86, 327-331.
- Lubahn, D.B., Joseph, D.R., Sullivan, P.M., Willard, H.F., French, F.S., & Wilson, E.M. (1988). *Science* 240, 327-330.
- Trapman, J., Klassen, P., Kuiper, G.G.J.M., van der Korput, J.A.G.M., Faber, P.W., van Rooij, H.C.J., van Kessel, A.G., Voorhorst, M.M., Mulder, E., & Brinkmann, A.D. (1988). *Biochem. Biophys. Res. Comm.* 153, 241-248.
- Ladias, J.A.A., & Karathanasis, S.K. (1991). *Science* 251, 561-565.
- Dumas, B., Harding, H.P., Choi, H., Lehmann, K.A., Chung, M., Lazar, M.A., & Moore, D.D. (1994). *Mol. Endocrinol.* 8, 996-1005.
- Wang, L.-H., Tsai, S.Y., Cook, R.G., Beattie, W.G., Tsai, M.-J., & O'Malley, B.W. (1989). *Nature*, 340, 163-166.
- Ritchie, H.H., Wang, L.H., Tsai, S., O'Malley, B.W., & Tsai, M.J. (1990). *Nucleic Acids Res.* 18, 6857-6862.
- Zanaria, E., Muscatelli, F., Bardoni, B., Strom, T.M., Guioli, S., Guo, W., Lalli, E., Moser, C., Walker, A.P., McCabe, E.R.B., Meitinger, T., Monaco, A.P., Sassone-Corsi, P., & Camerino, G. (1994). *Nature* 372, 635-641.
- Koelle, M.R., Segraves, W.A., & Hogness, D.S. (1992). *Proc. Natl. Acad. Sci. USA* 89, 6167-6171.
- Ayer, S., Walker, N., Mosammaparast, M., Nelson, J.P., Shilo, B.Z., & Benyajati, C. (1993). *Nucleic Acids Res.* 21, 1619-1627.
- Segraves, W.A., & Hogness, D.S. (1990). *Genes & Dev.* 4, 204-219.
- Stone, B.L., & Thummel, C.S. (1993). *Cell* 75, 307-320.
- Miyajima, N., Horiuchi, R., Shibuya, Y., Fukushige, S.-i., Matsubara, K.-i., Toyoshima, K., & Yamamoto, T. (1989). *Cell* 57, 31-39.

(continued)

Table 1. Continued

16. Miyajima, N., Kadowaki, Y., Fukushige, S., Shimizu, S., Semba, K., Yamanashi, Y., Matsubara, K., Toyoshima, K., & Yamamoto, T. (1988). *Nucleic Acids Res.* 16, 11057–11074.
17. Koelle, M.R., Talbot, W.S., Segraves, W.A., Bender, M.T., Cherbas, P., & Hogness, D.S. (1991). *Cell* 67, 59–77.
18. Tsukiyama, T., Ueda, H., Hirose, S., & Niwa, O. (1992). *Mol. Cell Biol.* 12, 1286–1291.
19. Rothe, M., Nauber, U., & Jäckle, H. (1989). *The EMBO J.* 8, 3087–3094.
20. Green, S., Walter, P., Kumar, V., Krust, A., Bornert, J.-M., Argos, P., & Chambon, P. (1986). *Nature* 320, 134–139.
21. Greene, G.L., Gilna, P., Waterfield, M., Baker, A., Hort, Y., & Shine, J. (1986). *Science* 231, 1150–1154.
22. Giguère, V., Yang, N., Segui, P., & Evans, R.M. (1988). *Nature* 331, 91–94.
23. Lavorgna, G., Ueda, H., Clos, J., & Wu, C. (1991). *Science* 252, 848–851.
24. Ohno, C.K., & Petkovich, M. (1993). *Mech. Develop.* 40, 13–24.
25. Chen, F., Cooney, A.J., Wang, Y., Law, S.W., & O'Malley, B.W. (1994). *Mol. Endocrinol.* 8, 1434–1444.
26. Hollenberg, S.M., Weinberger, C., Ong, E.S., Cerelli, G., Oro, A., Lebo, R., Thompson, E.B., Rosenfeld, M.G., & Evans, R.M. (1985). *Nature* 318, 635–641.
27. Sladek, F.M., Zhong, W.M., Lai, E., & Darnell, J.E. (1990). *Genes & Dev.* 4, 2353–2365.
28. Nauber, U., Pankratz, M.J., Kienlin, A., Seifert, E., Klemm, U., & Jäckle, H. (1988). *Nature* 336, 489–492.
29. Tugwood, J.D., Isseemann, I., & Green, S. (1992). *Genbank M81385*.
30. Baes, M., Gulick, T., Choi, H., Martinoli, M.G., Simha, D., & Moore, D.D. (1994). *Mol. Cell Biol.* 14, 1154–1152.
31. Arriza, J.L., Weinberger, C., Cerelli, G., Glaser, T.M., H, e., B.L., Housman, D.E., & Evans, R.M. (1987). *Science* 237, 268–275.
32. Milbrandt, J. (1988). *Neuron* 1, 183–188.
33. Hazel, T.G., Nathans, D., & Lau, L.F. (1988). *Proc. Natl. Acad. Sci. USA* 85, 8444–8448.
34. Law, S.W., Conneely, O.M., DeMayo, F.J., & O'Malley, B.W. (1992). *Mol. Endocrinol.* 6, 2129–2135.
35. Smith, D.P., Mason, C.S., Jones, E.A., & Old, R.W. (1994). *Nucleic Acids Res.* 22, 66–71.
36. Becker-André, M., André, E., & DeLamarier, J.F. (1993). *Biochem. Biophys. Res. Comm.* 194, 1371–1379.
37. Isseemann, I., & Green, S. (1990). *Nature* 347, 645–650.
38. Dreyer, C., Krey, G., Keller, H., Givel, F., Helftenbein, G., & Wahli, W. (1992). *Cell* 68, 879–887.
39. Conneely, O.M., Sullivan, W.P., Toft, D.O., Birnbaumer, M., Cook, R.G., Maxwell, B.L., Zarucki-Schulz, T., Greene, G.L., Schrader, W.T., & O'Malley, B. (1986). *Science* 233, 767–771.
40. Jeltsch, J.M., Krozowski, Z., Quiron-Stricker, C., Gronemeyer, H., Simpson, R.J., Gamier, J.M., Krust, A., Jacov, F., & Chambon, P. (1986). *Proc. Natl. Acad. Sci. USA* 83, 5424–5428.
41. de Thé, H., Marchio, A., Tiollais, P., & Dejean, A. (1987). *Nature* 330, 667–670.
42. Petkovich, M., Brand, N.J., Krust, A., & Chambon, P. (1987). *Nature* 330, 444–450.
43. Giguère, V., Ong, E.S., Segui, P., & Evans, R.M. (1987). *Nature* 330, 624–629.
44. Lazar, M.A., Jones, K.E., & Chin, W.W. (1990). *DNA Cell B.* 9, 77–83.
45. Bonnelye, E., Vanacker, J.-M., Desbiens, X., Begue, A., Stehelin, D., & Laudet, V. (1994). *Cell Growth & Diff.* 5, 1357–1365.
46. Forman, B.M., Chen, J., Blumberg, B., Kliewer, S.A., Henshaw, R., Ong, E.S., & Evans, R.M. (1994). *Mol. Endocrinol.* 8, 1253–1261.
47. Searce, L.M., Laz, T.M., Hazel, T.G., Lau, L.F., & Taub, R. (1993). *J. Biol. Chem.* 268, 8855–8861.
48. Giguère, V., Tini, M., Flock, G., Ong, E., Evans, R.M., & Otulakowski, G. (1994). *Genes & Dev.* 8, 538–553.
49. Retnakaran, R., Flock, G., & Giguère, V. (1994). *Mol. Endocrinol.* 8, 1234–1244.
50. Mangelsdorf, D.J., E.S., O., Dyck, J.a., & Evans, R.M. (1990). *Nature* 345, 224–229.
51. Carlberg, C., Hoof van Huijsdijnen, R., Staple, J.K., DeLamarier, J.F., & Becker-André, M. (1994). *Mol. Endocrinol.* 8, 757–770.
52. Ikeda, Y., Lala, D.S., Luo, X.R., Kim, E., Moisan, M.P., & Parker, K.L. (1993). *Mol. Endocrinol.* 7, 852–860.
53. Mlodzik, M., Hiromi, Y., Weber, U., Goodman, C.S., & Rubin, G.M. (1990). *Cell* 60, 211–214.
54. Fjose, A., Nornes, S., Weber, U., & Mlodzik, M. (1993). *EMBO J.* 12, 1403–1414.
55. Pignoni, F., Baldarelli, R.M., Steingrimsson, E., Diaz, R.J., Patapoutian, A., Merriam, J.R., & Lengyel, J.A. (1990). *Cell* 62, 151–163.
56. Yu, R.T., Mckeown, M., Evans, R.M., & Umesono, K. (1994). *Nature* 370, 375–379.
57. Thompson, C.C., Weinberger, C., Lebo, R., & Evans, R.M. (1987). *Science* 237, 1610–1614.
58. Weinberger, C., Thompson, C.C., Ong, E.S., Lebo, R., Gruol, D.J., & Evans, R.M. (1986). *Nature* 324, 641–646.
59. Sap, J., Munoz, A., Damm, K., Goldberg, Y., Ghysdael, J., Leutz, A., Beug, H., & Vennstroem, B. (1986). *Nature* 324, 635–640.
60. Chang, C., Kokontis, J., Acakpo-Satchivi, L., Liao, S., Takeda, H., & Chang, Y. (1989). *Biochem. Biophys. Res. Commun.* 165, 735–741.
61. Chang, C., Kokontis, J., Liao, S.S., & Chang, Y. (1989). *J. Steroid Biochem.* 34, 391–395.

(continued)

Table 1. Continued

62. Chang, C.S., Dasilva, S.L., Ideta, R., Lee, Y.F., Yeh, S.Y., & Burbach, J.P.H. (1994). Proc. Natl. Acad. Sci. USA 91, 6040–6044.
63. Song, C., Kokontis, J.M., Hiipakka, R.A., & Liao, S. (1994). Proc. Natl. Acad. Sci. USA 91, 10809–10813.
64. Oro, A.E., Mckeown, M., & Evans, R.M. (1990). Nature 347, 298–301.
65. Shea, M.J., King, D.L., Conboy, M.J., Miriani, B.D., & Kafatos, F.C. (1990). Genes & Dev. 4, 1128–1140.
66. Henrich, V.C., Sliter, T.J., Lubahn, D.B., MacIntyre, A., & Gilbert, L.I. (1990). Nucl. Acids Res. 18, 4143–4148.
67. Baker, A.R., McDonnell, D.P., Hugues, M., Crisp, T.M., Mangelsdorf, D.J., Haussler, M.R., Pike, J.W., Shine, J., & O'Malley, B.W. (1988). Proc. Natl. Acad. Sci. USA 85, 3294–3298.

contains nuclear localization signal sequences; and (4) the E domain or ligand-binding domain. Certain receptors contain an additional domain F, whose function is yet to be determined. A detailed discussion of the different domains will be found below in the sections dealing with the different receptor functions.

When this protein domain arrangement was also found in the thyroid hormone receptor, it was speculated that steroid and thyroid hormone receptors evolved from a single ancestral gene and that further undiscovered hormone receptors sharing the same structure might exist. Indeed, this hypothesis was confirmed by the cloning of a large number of additional related receptors (Figure 3 and Table 1), based on the highly conserved sequence of the DNA-binding domain. Thus, all of these receptors are now grouped together in the superfamily of nuclear receptors. After the steroid and thyroid hormone receptors, the next receptors cloned were the receptors for retinoic acid. Two subtypes of receptors (retinoic acid receptors or RARs and retinoid X receptors or RXRs) were isolated. In fact, it was only after their cloning that all-*trans*-retinoic acid and 9-*cis*-retinoic acid were identified as ligands for RARs and 9-*cis*-retinoic acid alone for RXRs. Although the effects of retinoids on cellular differentiation and embryogenesis have been known for some time, their mechanism of action was not understood. The discovery of specific retinoid receptors has undoubtedly accelerated the analysis of the physiological roles of retinoids.

Beside receptors with known ligands, many receptors have been cloned for which no ligands have yet been identified. These receptors are putative nuclear hormone receptors and are usually called orphan receptors. Whether each of these orphan receptors is activated by a ligand or whether some of them may be constitutively active or inactive and therefore are acting as repressors rather than activators is not known at the moment. For some orphan receptors, activators have been identified, but it is not yet clear whether these substances act as ligands by binding directly to the receptors. One example is the peroxisome proliferator-activated receptor (PPAR). PPARs are activated by natural fatty acids and xenobiotic peroxisome proliferators such as fibrate hypolipidemic drugs (Keller and Wahli, 1993). Activation of PPARs by fatty acids raises the question as to whether diverse metabolites or nutrients can be ligands of nuclear hormone receptors. Such receptors might represent ancient forms of ligand-activated transcription factors, in analogy to

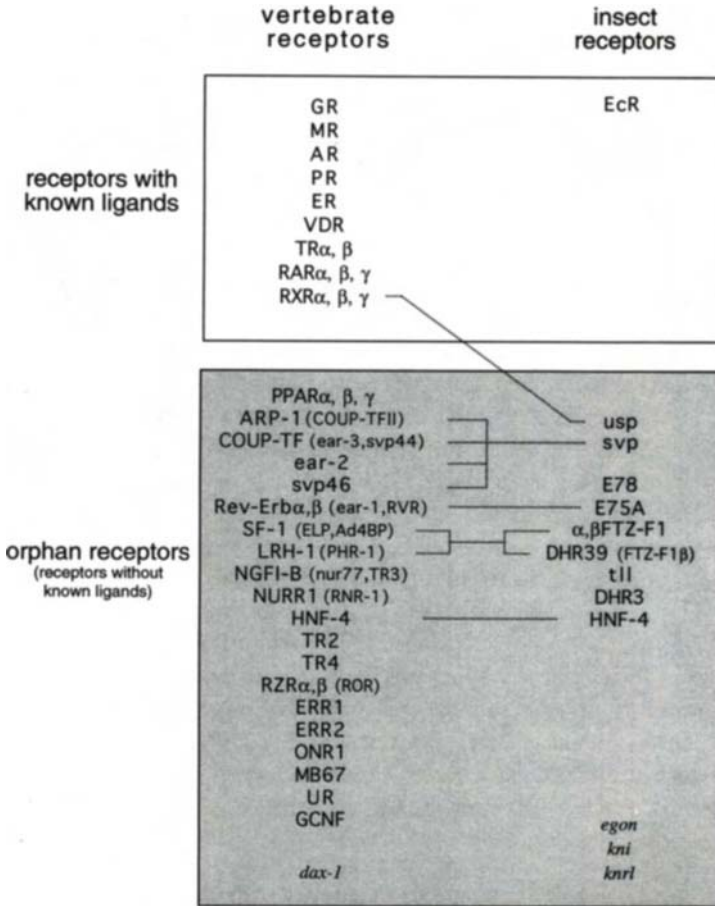

Figure 3. Classification of cloned nuclear receptors into receptors with identified ligands and receptors for which no ligands have been identified so far. The latter receptors are referred to as orphan receptors. In addition, receptors isolated from vertebrates and insects are distinguished and receptor homologues between the two phyla are indicated by dotted lines. For receptor abbreviations and for receptor references concerning their first cloning see Table 1. Different names of the same receptor, which are not referred to in this chapter are placed in brackets. Distant receptor variants from vertebrates and *Drosophila*, which do not completely conform to the domain structure presented in Figure 2, are in italics.

prokaryotic gene regulation by metabolites such as sugars and amino acids (O'Malley, 1989). Further metabolite-regulated nuclear hormone receptors may include the FTZ-F1 family of receptors (SF-1, ELP, and LRH-1), ARP-1, COUP-TF, or NGFI-B, because these receptors are involved in the expression of enzymes associated with the control of metabolic pathways in the production of lipoproteins and steroidogenesis.

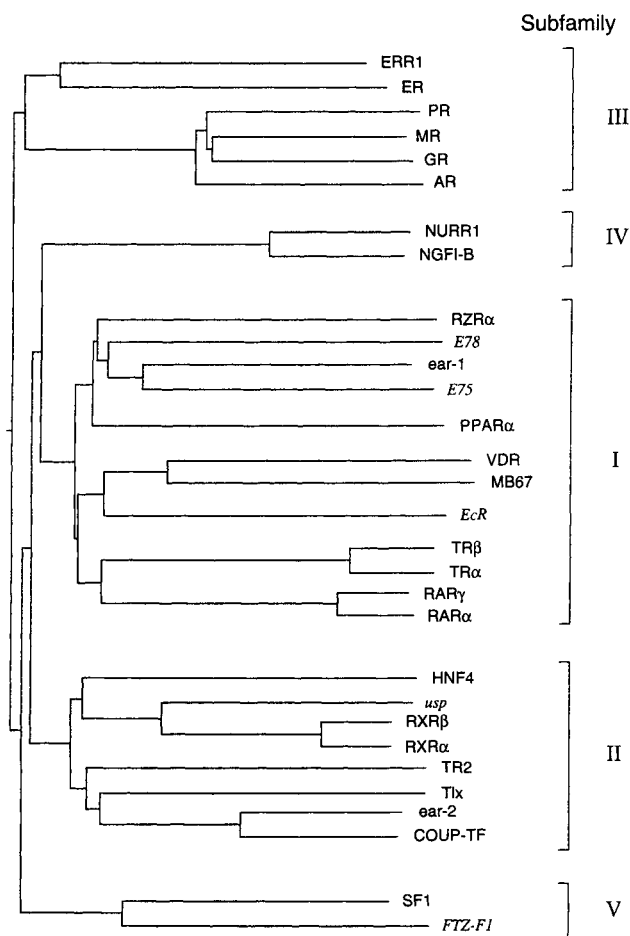

Figure 4. Phylogenetic tree of steroid hormone and related receptors based on sequence alignment and comparison of domains C, D, and E. Five groups of receptors are distinguished as indicated (I–V). Receptor abbreviations are explained in Table 1 and the sequences are from human receptors except for those that are from *Drosophila* (italics), Tlx (chicken), and SF-1 (mouse). (Courtesy of V. Laudet).

Many nuclear hormone receptors have also been described in insects. The receptor for the steroid hormone ecdysone is responsible for molting and metamorphosis of insect larvae. In addition, several orphan receptors have been cloned, many of which are homologous to vertebrate receptors (Figure 3). This suggests conservation of function of these receptors from insects to vertebrates. An orphan receptor (COUP-TF) has also been cloned from sea urchin. The common origin of nuclear hormone receptors is also supported by a phylogenetic tree derived from the comparison of the amino acid sequences (Figure 4). Thus, it appears that the functional paradigm of nuclear hormone receptors has been developed a long time ago and has been well conserved during evolution. However, and perhaps surprisingly, no nuclear hormone receptors have been cloned from plants so far.

In summary, the family of nuclear hormone receptors represents one of the largest families of transcription factors. It includes the classical steroid and thyroid hormone receptors, the retinoid hormone receptors, as well as many orphan receptors. They all share the same protein domain organization and are the only known direct ligand-regulated transcription factors in higher eukaryotes.

REGULATORY MECHANISMS OF RECEPTOR ACTIVITY

Ligand Binding

Mutagenesis of steroid receptors revealed that hormone binding is mediated by the receptor domain E (Figure 2). This domain is approximately 200 amino acids in length and is linked to the DNA-binding domain C, via the so-called hinge domain D. Ligand-binding assays with the cloned mouse estrogen receptor revealed a dissociation constant (K_d) of 0.1 nM, confirming earlier measurements with crude receptor preparations. The E domain is essential and sufficient for specific hormone binding. This was demonstrated by an elegant series of experiments, involving chimeric receptors (Evans, 1988). The ligand-binding domain (LBD) from the glucocorticoid receptor (GR) was substituted with that of the estrogen receptor (ER) to produce a chimeric receptor that contains the DNA-binding domain of the GR and the LBD of the ER. The transcriptional activation properties of this hybrid receptor were then analyzed. In contrast to the wild-type GR, the GR-ER chimeric receptor activated glucocorticoid responsive genes in the presence of estrogens but not in the presence of glucocorticoids, demonstrating unequivocally that ligand binding and DNA binding are independent functions exerted by domain E and C, respectively.

Structural information of the LBD has been gained by X-ray crystallography of the unliganded human RXR α LBD and the LBD of rat Tr α 1 and human RAR γ bound to their corresponding hormones (Bourguet et al., 1995; Wagner et al., 1995; Renaud et al., 1995). The overall three-dimensional structures of the three LBDs are very similar, consisting of 11 or 12 α -helices and two or four short β -strands. The α -helices account for about 65% of the whole LBD and are organized in a way that has been described as an antiparallel α -helical 'sandwich'. A hydrophobic

cavity is created by this arrangement that serves as a hormone-binding pocket. Hormone is locked in this pocket by specific hydrophobic interactions and hydrogen bonds. Comparison of the liganded and unliganded LBDs indicates a conformational change upon ligand binding. The major difference resides in the position of helix 12 at the carboxy terminus, which appears to function as a movable 'lid' of the ligand-binding pocket. Based on the currently available LBD structures from three different nuclear receptors, it is reasonable to assume that there is a common fold for all nuclear receptor LBDs. However, further structure analysis is required to determine specific binding contracts of other hormones to their corresponding receptors. Furthermore, structures of whole receptors bound to DNA need to be solved to fully elucidate the molecular mechanisms that govern receptor dimerization and transcriptional activation.

How does hormone binding activate nuclear receptors to induce gene transcription? Purification of steroid hormone receptors in the 1960s by sucrose gradient ultracentrifugation revealed two receptor forms: a 4S complex and a faster sedimenting 8-10S multiprotein complex, containing in addition to the receptor the heat shock proteins (hsp) hsp90, hsp70, hsp56, and other proteins (Figure 1). The 8-10S complex does not bind DNA, but can be converted to the 4S DNA-binding complex upon hormone addition. This suggested that the role of the hormone is simply to trigger the release of the accessory proteins in order to allow DNA binding and gene activation. However, *in vitro* transcription experiments with the cloned progesterone receptor demonstrate that when receptors stripped off the accessory proteins, they still depend on the hormone to induce gene transcription (Banahmad and Tsai, 1993). Moreover, certain receptors, such as the thyroid and retinoid hormone receptors, do not form stable complexes with hsp 90. They bind DNA in the absence of hormone, but they still require hormone to become transcriptionally active. Thus, this suggests that the non-liganded DNA-bound receptor adopts an inactive configuration that is changed into an active configuration upon ligand binding. Such a conformational transition was confirmed by proteolytic digestion assays. Free and ligand-bound receptors, subjected to limited proteolysis, generate different resistant protein fragment patterns, demonstrating different receptor conformations.

In summary, there is substantial evidence that the central mechanism of nuclear receptor activation by the ligand consists in a conformational change of the LBD. First, this leads to the dissociation of hsp's and other associated proteins, where it applies, resulting in DNA binding of the receptor, and second, to the uncovering of receptor regions that are able to regulate gene transcription.

It is not clear why some nuclear receptors, such as the steroid receptors, form stable multiprotein complexes with hsp90 and others do not. In the case of the glucocorticoid receptor, the hsp-receptor complex is usually found in the cytoplasm in the absence of hormone (Figure 1). Upon addition of hormone, the complex dissociates and the receptor moves to the nucleus. Thus, the hsp-receptor complex has been termed a "docking" complex to describe the apparent fact that this complex keeps the glucocorticoid receptor from entering the nucleus (Pratt,

1992). Hsp90 binds as a homodimer to one receptor molecule and the binding sites have been mapped in several steroid receptors. It is assumed that hsp90 acts as a chaperone, assisting in receptor folding and assembly. Similarly, hsp70 may have a chaperone function, although direct evidence is lacking.

The third well-characterized component of the multiprotein complex, hsp56, has been identified as a member of the immunophilin protein family. Immunophilins are proteins that bind immunosuppressants such as cyclosporin, rapamycin, or FK506. Since all of these proteins present a rotamase activity (peptidyl-prolyl-isomerase activity), which is important during the folding process of polypeptide chains, it is thought that hsp56 and other immunophilins function also as molecular chaperones (Smith and Toft, 1993).

In summary, while there is some evidence for a role of hsp's in the folding and maintenance of receptor conformation, the significance of receptor-associated proteins in the control of steroid hormone signal transduction remains to be elucidated.

Ligand-Independent Regulatory Mechanisms

It has been reported that certain steroid hormone receptors, when transiently expressed in cultured cells, can be activated in the absence of hormone by various agents that induce protein phosphorylation, such as 8-bromo-cAMP (activator of protein kinase A) or okadaic acid (inhibitor of phosphatases 1 and 2A). In addition, dopamine, specifically acting through D1 dopamine receptors, leads to the activation of estrogen and progesterone, but not glucocorticoid receptors (Power et al., 1992). Furthermore, phosphorylation of a serine in the A/B domain of the ER influences its activity to stimulate gene transcription. Thus, phosphorylation may hormone-independently induce or at least fine-tune receptor activity. It also implies that there are signaling interactions between hormone systems involving membrane receptors (dopamine receptors) and nuclear receptors. In fact, nuclear hormone receptors are subject to multiple phosphorylation events mainly on serines which is particularly observed following hormonal activation (Orti et al., 1992). Nevertheless, the significance of hormone-independent receptor activation and receptor phosphorylation remains to be demonstrated *in vivo*.

Another potential ligand-independent regulatory mechanism of nuclear hormone receptor activity involves direct interaction with the Ca²⁺ binding protein, calreticulin. It has been shown that calreticulin binds specifically to a conserved sequence of amino acids within the domain C of the glucocorticoid, androgen, and all-*trans*-retinoic acid receptor. This binding blocks DNA binding of the receptors and thus inhibits their transcriptional activity (Burns et al., 1994; Dedhar, 1994). However, as in the case of receptor phosphorylation, the role of this process *in vivo* remains to be established.

Inhibition of Receptor Activity by Antihormones

Compounds that block the action of steroid and related hormones are of great pharmaceutical importance. Here, we will focus on the inhibition of hormone action at the level of the receptor, although there are other ways to repress hormone signaling such as inhibition of endogenous hormone production. Compounds that bind to hormone receptors but do not lead to receptor activation are called antagonists or antihormones. Synthetic receptor antagonists have been developed for all classical steroid hormone receptors and recently also for retinoid hormone receptors. No antagonists have yet been described for thyroid hormone receptors. Interestingly, despite intensive searches, no endogenous antihormones have been found. Most mechanistic data on the molecular action of antihormones has been obtained for the two antiestrogens, tamoxifen and ICI 164'384, and the antiprogesterin and antiglucocorticoid RU486. All three compounds bind with high affinity to their respective receptors and block at least some hormone function *in vivo*. Binding of tamoxifen and RU486 does not inhibit receptor DNA binding, but blocks only transcriptional activation. On the contrary, binding of ICI 164'384 appears to enhance receptor turnover and leads to nuclear exclusion of the receptor.

ICI 164'384 appears to be a pure antagonist, whereas tamoxifen and RU486 are mixed agonist-antagonists, depending on the cell type and the target gene. Ligands are called mixed agonist-antagonists when they only partially block hormone receptors, because they possess a low intrinsic agonistic property. Thus, some receptor activation can result from the application of such antihormones. This has to be taken into consideration when medically using such antihormones. Gene transcription activation studies in cell cultures suggest that the mixed agonist-antagonist effect of tamoxifen and RU486 is due to the incomplete inhibition of receptor regions (activation functions, AF) that are responsible for transcriptional activation. Thus, tamoxifen and RU486 repress only AF-2 located in the LBD, whereas the activity of AF-1 in the N-terminal A/B domain is not inhibited. The molecular mechanism of how AF-2 is repressed, whereas AF-1 is still functional, is poorly understood. Nevertheless, limited proteolytic digestion assays indicate that antihormone binding may induce a conformational change of the LBD in which AF-2 is nonfunctional or masked (Baniahmad and Tsai, 1993).

NUCLEAR HORMONE RECEPTORS BIND TO SHORT DNA SEQUENCES WITHIN TARGET GENE PROMOTERS CALLED HORMONE RESPONSE ELEMENTS

Positive Hormone Response Elements

Nuclear hormone receptors regulate gene transcription by binding to short DNA sequences, which are usually found at some distance upstream of the transcription initiation site. These sequences are called hormone response elements (HREs).

They are classical enhancer or silencer DNA sequences which, independent of their position and orientation in the promoter of a gene, confer regulation of mRNA synthesis. The binding affinity of receptors to HREs is usually in the nanomolar range, as for example in the case of the mouse estrogen receptor, which has a *K_d* of 1 nM. The first HREs to be identified were the glucocorticoid response element (GRE) and the estrogen response element (ERE). Sequence comparisons of GREs and EREs from different gene promoters revealed two consensus sequences AGAACANNNTGTTCT and AGGTCAANNNTGACCT, respectively (Figure 5). Both HREs are organized as a 15 base pair (bp) palindrome, consisting of two identical 6 bp half-sites spaced by three nonspecific nucleotides. This suggested that a receptor dimer is the functional complex with each monomer binding to one half-site. Indeed, this has been confirmed by DNA-binding experiments using mixtures of truncated and full-length receptors, and by gene transcription activation studies using HREs with mutated half-sites (Green and Chambon, 1988). GRE and ERE are distinguished by the different half-site sequences AGAACA and AGGTCA, respectively. Astonishingly, analysis of progesterone, androgen, and mineralocorticoid receptor response elements revealed the same sequences as for the GRE, raising the question about the specificity of HREs, which is discussed on p. 286.

In contrast to the classical steroid hormone receptors, the receptors for all-*trans*-retinoic acid (RAR), thyroid hormone (TR), and vitamin D (VDR), and some orphan receptors such as PPAR, COUP, and ARP-1 bind to HREs that consist of direct repeats or inverted palindromes of AGGTCA-like half-sites (Figure 5). Moreover, these receptors bind as heterodimers to their HREs with the promiscuous partner RXR, the receptor for 9-*cis*-retinoic acid. Specificity of HREs is achieved by the number of nonconserved nucleotides between the half-sites; e. g. PPAR/RXR binds preferentially to a direct repeat of the AGGTCA motif with a one nucleotide spacer (DR-1), RXR/VDR to a DR-3, RXR/TR to a DR-4, and RXR/RAR to a DR-5. Also in contrast to the classical steroid hormone receptors, there is no strict specificity for the binding of a given heterodimer to a single HRE. For example, RXR/RAR heterodimers can bind to many, differently organized HREs, as illustrated in Figure 5. In addition, some HREs, such as a DR-1, are recognized by several different receptor dimers and VDR recognizes two different HREs, depending on whether it binds as a heterodimer with RXR or as a homodimer. Thus, there is a complex diversity of HREs that bind various receptor dimers. Such a system of HREs with different degrees of specificity allows very elaborate ways of multihormone gene control by different nuclear hormone receptors, which is in striking contrast to a hypothetical system where each nuclear hormone receptor system would have its own and unique HRE. It is obvious that the former system is better adapted to cope with the various requirements of hormonal control of cell-specific differential gene expression during development and in the adult.

A third mode of nuclear hormone receptor binding to response elements is used by the orphan receptors of the NGFI-B family, FTZ-F1 family, as well as Rev-erbo,

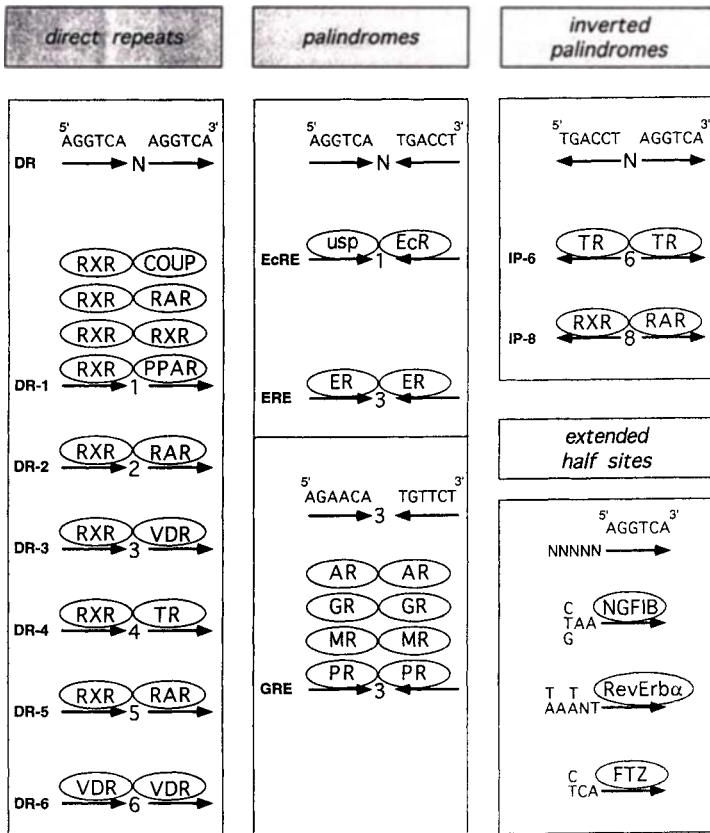

Figure 5. Compilation of hormone response elements. They are classified according to the arrangement of their core sequences into direct repeats (DR), palindromes, inverted palindromes (IP), or extended half-sites. One receptor molecule binds to one core sequence. To date, only two different consensus core sequences have been identified: AGAACA for the receptor group including the glucocorticoid receptor and AGGTCA for all the other receptors. Besides the nature of the core sequence, the spacing and arrangement of the core sequence within a response element determines which receptor homo- or heterodimer will bind to it. For DRs, a defined polarity of heterodimer-DNA complexes, RXR binding to the 5' core sequence, is observed at least in the case of RAR and TR. The examples indicated show that certain response elements allow binding of different receptor pairs such as a DR-1 or GRE. Furthermore, certain receptors can bind to different response elements such as RXR/RAR. Finally, a group of orphan receptors bind as monomers to single core sequences, where specific binding is determined by a short nucleotide sequence upstream of the core sequence. Receptor abbreviations are explained in Table 1 and the abbreviations of the steroid hormone response elements are as follows: EcRE, ecdysone response element; ERE, estrogen response element; GRE, glucocorticoid response element.

ROR α , and RZR. These receptors bind as monomers to so-called extended half-sites where a short region of 3–5 nucleotides 5' to the AGGTCA-like half-site is essential for high-affinity binding and where the nucleotide sequence determines specific recognition by the receptors. Sequence-specific binding to the extended half-sites is mediated by two protein domains within the DBD as will be discussed below.

The consensus HREs discussed so far and presented in Figure 5 represent a very simplified view of HREs. Most natural HREs that have been identified do not consist of perfect canonical AGGTCA or AGAACA half-sites. They are often weak or promiscuous HREs, and thus are frequently found in multiple copies. As a consequence of weak HREs, transcriptional activation by nuclear hormone receptors depends strongly on the interaction with other transcription factors, regulating the same gene. The sum of all of these interactions, as well as the influence of the local chromatin structure on gene activity, is termed the promoter context.

Only two different half-site consensus sequences of HREs, AGGTCA, and AGAACA, have been described to date. Specific recognition of these motifs by the estrogen and the glucocorticoid receptors is conferred by the DNA-binding domain (DBD). The three-dimensional structures of the DBD of the ER, GR, and RXR have been solved using nuclear magnetic resonance spectroscopy and X-ray crystallography. All three DBDs exhibit the same overall conformation, which is indicative of the high degree of amino acid sequence conservation (Figure 6). As was expected from sequence-derived structure predictions, the DBD is folded into two zinc-binding subdomains, which are called zinc fingers. The zinc atoms in each finger is tetrahedrally coordinated by four cysteines that are absolutely conserved among all members of the nuclear hormone receptor superfamily (Figure 2). Each zinc finger consists of an extended loop and α -helix, which begins at the third Zn-coordinating cysteine and extends over a region of about 13 amino acids. The two α -helices are amphipathic and they interact at a right angle through the hydrophobic face (Figure 6). Three amino acids in the α -helix of the first zinc finger (1–3), which makes specific nucleotide contacts in the major groove of the DNA, are crucial for the recognition of the two half-site sequences. They are glycine, serine, and valine in the case of receptors, which bind to AGAACA half-sites, and glutamic acid or aspartic acid (first position), glycine or serine (second position), and glycine, serine, or alanine (third position) in the case of AGGTCA binding receptors (Figure 2). Although all three amino acids face the major groove of the DNA, only one of them makes a base contact. In the case of the GR, valine makes a favorable van der Waals contact with the third T of the GRE half-site TGTTCT (complementary strand of AGAACA), and in the case of the ER, glutamic acid forms a hydrogen bond with the first C of TGACCT (complementary strand of AGGTCA). Beside these discriminatory contacts, there is a complex array of protein–DNA contacts, which confer high-affinity binding (Schwabe and Rhodes, 1991; Freedman and Luisi, 1993).

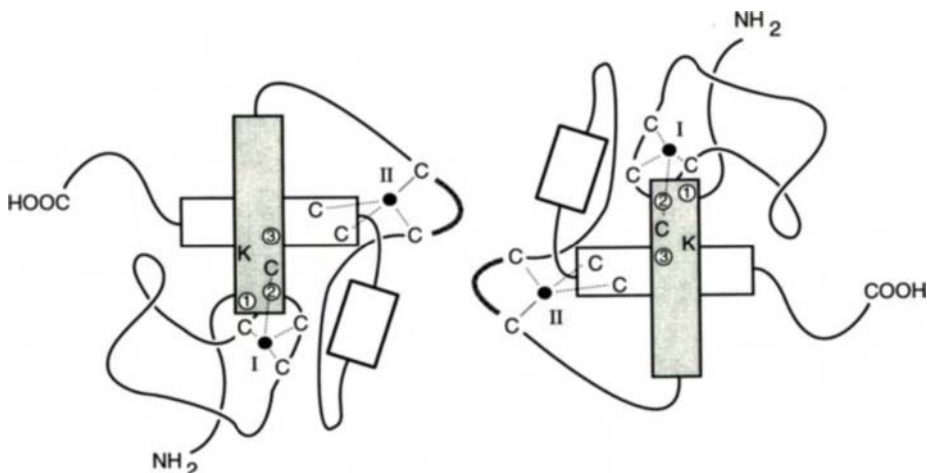

Figure 6. Schematic model of the glucocorticoid receptor DNA-binding domain dimer viewed from the DNA. The amino- and carboxy-termini are indicated and α -helices are shown as rectangles. The two zinc atoms of each molecule, coordinated by four cysteines (C), are numbered I and II. The P-Box subdomain in the α -helix facing the DNA (*shaded*) and the D-Box subdomain, which is involved in dimerization, are illustrated as in Figure 2. (Adapted from Luisi et al., 1991).

Another important region of the DBD is the sequence between the first pair of cysteines in the second zinc finger. This sequence has been termed D-box because it is involved in dimerization of the DBDs (Figure 2). The D-box constitutes the contact point between the DBDs of ER or GR homodimers bound to their palindromic response elements (Figure 6). The other major dimerization function of nuclear hormone receptors involves the ligand-binding domain (LBD). This is thought to consist of conserved repeats of hydrophobic amino acids that may form a coiled-coil dimerization interface. In the case of the ER, this dimerization function in the LBD is stronger than the D-box dimerization interface in the DBD.

In contrast to the GR and ER, the configuration and structure of receptor homo- and heterodimer binding to direct repeat or inverted palindrome response elements is only beginning to be understood. Mutagenesis experiments indicate that RXR/RAR, RXR/TR, and RXR/VDR heterodimers bind to direct repeats in a head-to-tail configuration. Furthermore, these experiments also suggest that RXR always binds to the upstream 5' half-site, whereas RAR, TR, or VDR bind to the downstream or 3' half-site (Figure 5; Glass, 1994). In the case of receptors that bind as monomers, protein domain swap experiments between the two orphan receptors, NGFI-B and SF-1, indicate that a region at the carboxy terminus of the DBD, termed A-box, is responsible for the sequence-specific recognition of the half-site exten-

sion. Three amino acids within this A-box make specific contacts with base pairs in the minor groove upstream of the AGGTCA half-site sequence. However, the three-dimensional structure of receptor monomer–DNA complexes remains to be elucidated. Whether they are similar for all receptors which bind as monomers, is not yet known.

Negative Hormone Response Elements

Steroid hormones exert important negative regulatory functions such as the inhibition of their own synthesis through negative feedback control. Despite its physiological significance, the negative actions of steroid hormones are not as well understood as the positive effects that are predominantly caused by activation of gene transcription. Mechanistically, two modes of transcriptional repression by nuclear hormone receptors can be distinguished: (1) receptor binding to specific so-called negative HREs, thus directly inhibiting gene transcription; and (2) repression of transcription without receptor binding to HREs. The latter is thought to involve protein–protein interactions between nuclear receptors and other transcription factors that are in solution or bound to DNA, thus resulting in abolition of gene transcription. These mechanisms leading to inhibition of gene expression will be discussed on p. 278 and only negative HRE will be discussed here.

Compared to positive HREs, very few negative HREs have been identified and they concern only the GR and the TR. Two well-studied genes containing negative GREs are the gene encoding the common α -subunit of glycoprotein hormones, such as luteinizing and follicle stimulating hormone, and the proliferin gene, which encodes a growth factor. Transcriptional activation of these genes by the positively acting transcription factors CREB (cAMP responsive element-binding protein) and AP-1 (*jun/fos*) is efficiently inhibited by glucocorticoids. In both cases, GR-binding sites were mapped and found to be overlapping or closely adjacent to binding sites of CREB and AP-1, respectively. However, these negative glucocorticoid response elements (nGRE), when taken out of their natural promoter context and placed upstream of a heterologous promoter, were not functional or failed to become positive HREs. Such observations are consistent with the model that GR bound to nGREs represses transcription by inhibition of the binding and/or functioning of adjacent, otherwise positively acting transcription factors.

Gene promoter elements that serve as binding sites for more than one transcription factor, such as these nGREs in the proliferin gene which binds GR and AP-1, have been termed composite response elements (Miner and Yamamoto, 1991). The hypothesis states that such composite elements contain multiple degenerate transcription factor binding sites, which allow either positive or negative gene regulation, depending on the actual composition of the multitranscription factor DNA complex. Due to the variable nature of these composite response elements, it is not surprising that sequence comparison did not result in a clear consensus sequence as in the case of positive GREs. Correspondingly, weak binding of GR alone to

these degenerate GREs is observed. Nevertheless, it is thought that a stable multiprotein–DNA complex is formed on composite GREs by the binding of other transcription factors to adjacent sites. This would correspond to the observed importance of the flanking sequences of composite GREs. The exact molecular structure of such complexes and how this leads to transcriptional repression rather than activation are not understood.

Similar repression mechanisms as for the GR have also been described for the thyroid hormone receptor (TR). Negative thyroid hormone response elements (nTREs) have been identified in the thyroid-stimulating hormone (TSH) α -gene, the growth hormone (GH) gene, and the epidermal growth factor receptor (EGFR) gene. In all three cases, only one AGGTCA-like half-site sequence has been found and, at least in the latter two cases, it appears that so far unknown auxiliary proteins are required for high-affinity TR binding. In contrast to nGREs described above, these nTREs are not located in the upstream promoter region, but are closely adjacent to the TATA-box or transcription initiation site. This suggests that repression may be conferred by blocking the formation of the transcription initiation complex. A second type of TR-mediated repression has been described for the chicken lysozyme gene promoter. Depending on the presence or absence of hormone, TR induces activation or repression of gene transcription through binding to a regular, positive TRE. There are indications that transcriptional repression by unliganded TR is brought about by direct inhibition of the formation of a functional preinitiation complex. Such an active repression has also been termed silencing (Renkawitz, 1990).

REGULATION OF GENE TRANSCRIPTION BY NUCLEAR HORMONE RECEPTORS

Receptor mutagenesis experiments revealed specific receptor domains, which are not involved in DNA binding, ligand binding, or receptor dimerization, but are essential for transcriptional activation of target genes. These regions have been termed transcription activation functions or, more recently, just activation functions (AF). Analyses of estrogen, progesterone, glucocorticoid, and retinoid receptors show that each receptor has two independent AFs: AF-1 located in the N-terminal A/B domain, and AF-2 located in the ligand-binding domain (Figure 2). AF-1 and AF-2 only become active upon hormone binding to the receptor and it is thought that the conformation of the free receptor, possibly stabilized by bound accessory proteins, precludes the AFs from being functional. AF-1 of receptor mutants devoid of the LBD becomes constitutively active, suggesting an inhibitory effect of the hormone-free LBD on AF-1. In contrast to nuclear hormone receptors that activate transcription, inhibitory receptors such as ARP-1 or COUP-TF may lack AFs or the latter may be substituted by active repressor functions. However, this remains to be demonstrated.

Nuclear hormone receptors activate gene transcription by enhancing the formation of functional preinitiation complexes, including general transcription factors such as the TATA-binding protein (TBP), TBP-associated proteins (TAFs), and RNA polymerase II (Figure 7). Since hormone response elements are generally found at a distance from the transcription initiation sites, it is believed that receptors establish physical contact directly or indirectly with components of the preinitiation complex such as TFIIB or TAFs by looping out of the intervening DNA. Indirect interactions are thought to involve bridging proteins that are also called transcription intermediary factors (TIFs; Figure 7). Collectively, proteins such as TIFs and TAFs, which are involved in transcriptional activation by enhancer-binding proteins are referred to as coactivators. Indications for direct interaction between receptors and the transcription initiation complex are provided by the demonstration of the binding of ER, PR, and COUP-TF to the general transcription factor TFIIB *in vitro*. Observations that AF-1 and AF-2 can function independently and in a cell-specific manner suggest the existence of different coactivators (Gronemeyer, 1991). Currently, such coactivators that are associated with nuclear hormone receptor function are only beginning to be identified. It appears that the transcription regulatory mechanisms of nuclear receptors, and particularly, their target proteins, have been highly conserved during evolution, since vertebrate nuclear receptors function in yeast, where no such or related receptors have yet been described.

Multiple receptor isoforms have been found for certain receptors such as the progesterone, thyroid, and retinoid hormone receptors. Receptor isoforms can be produced from a single gene either by alternative gene promoter usage or by differential splicing of primary RNA transcripts. Most of the isoforms that have been identified vary in length and sequence of the N-terminal A/B domain due to alternative exon usage. However, some receptor isoforms that vary at the C-terminus or in other receptor regions have also been described. There are several reasons for thinking that receptor isoforms may play important roles in specific gene activation. First, many isoforms of a given receptor are conserved across different species. Second, certain isoforms display differential spatial and temporal expression during development and in the adult. Third, many isoforms differ in the N-terminal A/B domain that contains the transcription activation function AF-1. Thus, it is conceivable that these isoforms differentially activate gene expression due to different AF-1s. Indeed, differential target gene activation by receptor isoforms has been shown in the case of the progesterone receptor, which exists in two isoforms A and B. The two isoforms are generated by alternative promoter usage and they differ only by 164 additional amino acids at the N-terminus in form B. Transcription from the ovalbumin gene promoter was stimulated by the short form A, but not by the longer form B.

In summary, specific regions of steroid hormone and related receptors that are called activation functions (AFs), are directly implicated in the stimulation of gene transcription. Analyses of many receptors show that there are principally two AFs: AF-1 in the A/B domain and AF-2 in the E domain. Binding experiments suggest

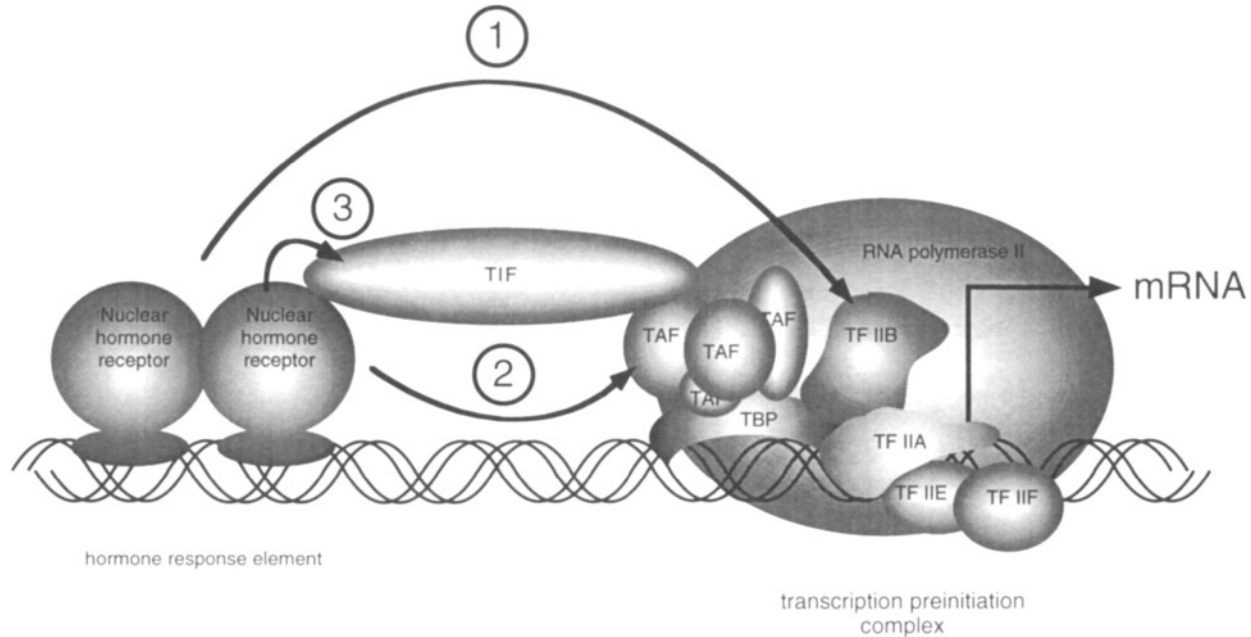

Figure 7. Models for regulation of gene transcription by nuclear hormone receptors. Receptors bound to hormone response elements activate gene transcription by enhancing the formation of the transcription preinitiation complex, containing the TATA-binding protein (TBP), several general transcription factors (TFIIA, B, E, and F are given as examples), several TBP-associated proteins (TAFs), and the RNA-polymerase II. The stimulated assembly of this multiprotein complex by nuclear receptors is thought to be mediated by interaction with general transcription factors such as TFIIIB (1), by interaction with TAFs (2), or via bridging proteins (3) named transcription intermediary factors (TIFs).

that AFs enhance the formation of transcription preinitiation complexes by binding to general transcription factors and/or to coactivators such as TIFs and TAFs. The specificity and stoichiometry of these multiprotein interactions is only beginning to be unraveled.

SIGNALING CROSSTALK BETWEEN DIFFERENT NUCLEAR HORMONE RECEPTORS AND BETWEEN RECEPTORS AND OTHER TRANSCRIPTION FACTORS

Natural gene promoters are composed of many transcription factor binding sites and therefore are subjected to multifactorial control (Figure 8). Thus, genes are regulated by various signals mediated by different transcription factors and further complexity arises from the specific interactions among the different transcription factors bound to the promoter. This may result in potentiation, or a decrease or even a shut off of gene expression. It is now important to discuss transcription factor interactions implicating nuclear hormone receptors and their consequences on gene activity. For mechanistic reasons, we will distinguish four modes: (1) homo- and heterotypic dimerization of nuclear hormone receptors on single response elements, (2) binding competition between nuclear hormone receptors and other transcription factors for the same DNA-binding site, (3) interaction of nuclear hormone receptor dimers that bind to adjacent response elements, and (4) interaction of nuclear hormone receptors with other transcription factors in the absence of DNA binding. Examples of mode (2) have already been discussed on p. 274 and thus, this mode will not be treated again here.

Dimerization of Nuclear Hormone Receptors

With the exception of certain orphan receptors that apparently bind as monomers, most of the analyzed nuclear hormone receptors bind to their response elements as hetero- or homodimers. Upon activation by hormone, all of the steroid hormone receptors form homodimers in solution and on their DNA response elements. In contrast to this, vitamin D, thyroid hormone, retinoid, and several orphan receptors form heterodimers with a common partner, RXR. Receptor dimerization is mediated by two different protein regions situated in the DNA-binding domain (D-box) and in the LBD. The dimerization region in the LBD seems to be the stronger region in the case of the homodimeric steroid receptors. The importance of the individual dimerization regions has not yet been assessed for the various heterodimers. However, DNA-binding experiments of the DBDs of vitamin D, thyroid, and retinoid hormone receptors suggest at least that the D-box-mediated dimerization function is important for the differential recognition of specific DNA response elements. Since RXR is the receptor for 9-*cis*-retinoic acid, this suggests that there is a convergence between the 9-*cis*-retinoic acid signaling pathway with the other hormone signaling pathways. However, since the *in vivo* concentrations of 9-*cis*-

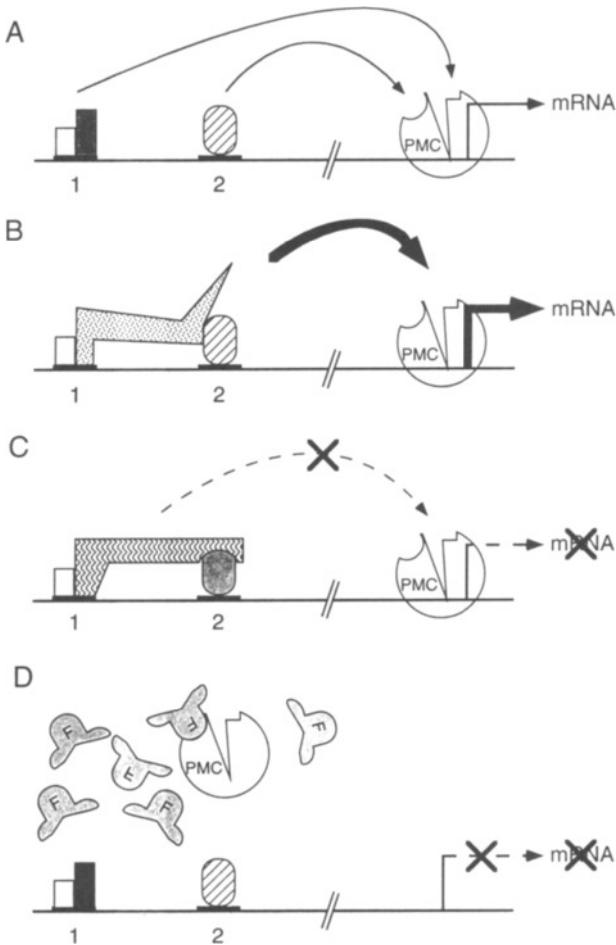

Figure 8. Examples of different modes of crosstalk between transcription factors, resulting in either activation or repression of gene transcription. Two binding sites for transcription factors (1, 2) are shown upstream of the gene transcription initiation site that binds the preinitiation multiprotein complex (PMC). **(A)** Additive transcriptional activation by two different (heteromeric and monomeric) transcription factors that contact the PMC independently. **(B)** Synergistic transcriptional activation by two transcription factors that coordinately interact with the PMC. **(C)** Repression of transcription by an inhibitory transcription factor that blocks the activity of a stimulatory transcription factor. If the transcription factor exerts its negative effect directly on the PMC, the process is referred to as silencing. **(D)** Squelching of transcription. A high concentration of a transcription factor or a coactivator (F) sequesters PMC or essential parts of it and thus, it is no longer available for other transcription factors bound to the gene promoter.

retinoic acid and their control are not well understood, the circumstances and extent to which 9-*cis*-retinoic acid influences the other hormone signaling pathways is not clear. Nevertheless, *in vitro* experiments demonstrate that to achieve full stimulation of gene transcription both receptors need to be activated by their hormone for several types of heterodimers. This implies at least a potentiating role for the RXR hormone system. Conversely, heterodimers where gene activation essentially depends on 9-*cis*-retinoic acid (i.e. activated RXR) have not yet been identified. Clearly, more detailed information about endogenous concentrations of 9-*cis*-retinoic acid, their regulation, and the activity of RXRs *in vivo* is required to understand the biological significance of the RXR signaling pathway and its cross-talk with other hormone systems. It is tempting to speculate that the linking of several hormonal systems to the RXR system could allow coordinate potentiation or inhibition, thus resulting in temporal and spatial regulation of gene activity during cellular differentiation and development.

Heterodimerization is a widespread mechanism that has been described for many transcription factor families. A reason for its frequent occurrence may be the benefit for the organism resulting from the various possibilities of gene control by the different combinations of related transcription factors. For example, activation of different genes has been observed for the VDR/RXR heterodimer and the VDR homodimer, due to recognition of different response elements. Furthermore, the inactivation of a transcription factor by dimerization with an inhibitory protein is also possible. This seems to be the mechanism of action for the TR α 2 isoform and the TR-derived *v-erbA* oncogene. Clear evidence for such dominant negative action has been obtained in the case of RAR mutants that lack part of their C-terminus. These dominant negative receptor mutants can still heterodimerize with RXR, and bind to DNA and to the ligand, but they have lost their ability to activate gene transcription, presumably due to the deletion of an activation domain (AF). If an excess of these mutants are expressed in cultured cells, they can completely block the stimulation of gene transcription by the wild-type receptor.

In summary, then, many nuclear hormone receptors form heterodimers. This serves as a means to increase the signaling diversity and allows the cross-talk between different hormone signaling systems. The ultimate effect is the ability of the cell to provide an appropriate response to the many signals received from its environment.

Interaction of Nuclear Hormone Receptor Dimers

It is not unusual that gene promoters contain multiple copies of a given hormone response element with, very often, imperfect sequences compared to the consensus sequence. For instance, several estrogen response elements have been identified in estrogen-responsive vitellogenin genes. DNA-binding experiments have shown that there is cooperative binding of receptor homodimers to adjacent response elements, which may explain at least part of the synergistic stimulation of transcrip-

tion from multiple hormone response elements. Although cooperative binding suggests direct interaction of receptor dimers, it is not known how receptor dimers interact with each other at the molecular level and what determines the specificity of these interactions.

Interaction of Nuclear Hormone Receptors with Other Transcription Factors in the Absence of DNA Binding

Many transcription factors such as NF-1, SP-1, or OTF synergistically activate gene transcription with nuclear hormone receptors when bound to adjacent sites within gene promoters. Since no cooperativity in the DNA binding of the individual proteins could be demonstrated, it has been inferred that either protein-protein interactions of these factors or the involvement of coactivators (e.g. TIFs or TAFs) that bind both factors are responsible for enhanced transcription. Similar protein-protein interactions are thought to be involved in the repression of the activity of some transcription factors by GR which is not bound to DNA. A prime example is the expression of the collagenase gene, which is induced by AP-1 (*fos/jun*) and repressed by GR (Schüle and Evans, 1991). Although GR does not bind to the AP-1 site, GR inhibition of transcription is conferred by this site. This suggests that protein-protein interactions between AP-1 and GR result in the blocking of transcription. Although DNA binding of GR is not involved, the DNA-binding domain is nevertheless required for repressor activity. Beside GR, RAR has also been shown to inhibit AP-1 activity by a similar mechanism. Blocking of the activity of AP-1—the product of the two proto-oncogenes, *jun* and *fos*—by GR and RAR may be one of the mechanisms by which nuclear hormone receptors suppress cellular proliferation. Such protein-protein interactions of different transcription factors leading to repression of gene transcription are reminiscent of an *in vitro* phenomenon termed “squenching” (Figure 8; Ptashne and Gann, 1990). A large excess of transcription factor is supposed to sequester target proteins such as TIFs, TAFs, or general transcription factors so that they are no longer available to form a transcription preinitiation complex, and thus transcription is not initiated.

NUCLEAR HORMONE RECEPTOR FUNCTIONS IN DEVELOPMENT AND HOMEOSTASIS

Rather than giving a complete catalog of nuclear hormone receptor mediated effects in a variety of target tissues, this chapter will outline receptor action principles that distinguish between effects on cellular metabolic pathways and effects on cellular differentiation. Such a distinction appears to be convenient with regard to our focus on the identification and analysis of receptor target genes and with respect to resulting pathological consequences if receptor malfunctions occur. Although most nuclear hormone receptors control both development and homeostasis, some receptors are more involved in one of these two processes. Receptors that are involved

in cellular proliferation and differentiation are likely to play a role in cancer, whereas receptors implicated in the control of metabolic processes may be involved in systemic disorders.

Mineralocorticoid Receptor

Mineralocorticoid receptor (MR) has been cloned from several species. It is encoded by a single gene, which gives rise to two mRNA isoforms that differ only in their 5' untranslated region and thus produce the same receptor protein. Interestingly, the MR is activated by aldosterone and also by the GR hormone cortisol, thereby creating a specificity problem. Nature has solved this by the selective inactivation of glucocorticoids in mineralocorticoid target tissues. These tissues express the enzyme 11β -hydroxysteroid dehydrogenase that catalyzes the conversion of glucocorticoids, but not aldosterone, to inactive metabolites. MRs appear to be exclusively implicated in the control of metabolic functions. This is consistent with the fact that no aldosterone-dependent tumors have hitherto been reported. A primary physiological role of MR is the control of Na^+ , K^+ , and H^+ concentrations in the extracellular fluid by regulating Na^+ retention from the renal tubules. At the molecular level, this is achieved by the transcriptional induction of sodium-specific apical membrane channels, as well as the induction of several genes, whose products are involved in energy (ATP) generation in the renal epithelial cells to increase sodium pumping activity. MR has also been found in distinct areas of the brain, such as the hippocampus, where its physiological role is less clear. Despite the existence of several MR target genes, no specific mineralocorticoid response element (MRE) has yet been identified. Thus, the only known MRE is the promiscuous glucocorticoid response element, which is also recognized by the androgen, glucocorticoid, and progesterone receptor.

Glucocorticoid Receptor

Although the glucocorticoid receptor (GR) predominantly regulates homeostatic processes, it is also implicated in certain cellular growth control processes. As in the case of the MR, the GR is encoded by a single gene, but there are no known isoforms. Cortisol, which is the most important glucocorticosteroid in humans, has a wide range of effects on presumably all organs and tissues of the body. First, it stimulates hepatic gluconeogenesis by increasing the synthesis of the enzymes involved in this pathway, whereas it exerts a catabolic effect on all other tissues, including: inhibition of DNA synthesis; acceleration of protein degradation in connective tissue, muscle, and bone; increase of lipolysis in adipose tissue; and inhibition of glucose uptake. These effects are particularly important under special homeostatic conditions such as fasting or stress, where it is essential to maintain a sufficient level of glucose in the blood. Second, glucocorticoids profoundly influence the immune system, an influence which can generally be summarized as an antiinflammatory effect. They act at the level of cytokine production. Furthermore,

glucocorticoids trigger apoptosis in thymocytes, which may involve positive regulation of genes associated with the induction of cell death. And third, GR may repress the expression of genes positively implicated in cellular proliferation. In summary, a variety of negative effects of glucocorticoids on cellular metabolism and inflammatory responses are known, but in contrast to the few stimulatory effects of glucocorticoids such as the transcriptional induction of tyrosine aminotransferase, tryptophan oxygenase, or mouse mammary tumor virus genes (Martinez and Wahli, 1991), none of these negative glucocorticoid actions are well understood at the molecular level, especially with regard to the identification of GR-regulated target genes.

Vitamin D Receptor

Vitamin D receptor (VDR) is encoded by a single gene and no isoforms have been described so far. VDR is considerably involved in the regulation of homeostatic processes. The active VDR hormone is 1,25-dihydroxycholecalciferol or vitamin D₃. Vitamin D controls Ca²⁺ and phosphate plasma levels by facilitating their absorption in the intestine. The other vitamin D target organs, which strongly express VDR, are bone, kidney, muscle, parathyroid glands, and skin. The crucial role of VDR in regulating bone development and calcium homeostasis is illustrated by the characteristic vitamin D deficiency diseases, such as common rickets (see p. 291). A direct involvement of VDR in bone development is also supported by the demonstration of a correlation between bone density and the existence of distinct VDR receptor alleles in the human. Several VDR target genes have been identified, including the genes for the two bone proteins, osteocalcin and osteopontin, the calcium-binding protein calbindin D-9k, and the 25-hydroxyvitamin D₃ 24-hydroxylase, which is involved in vitamin D metabolism. The consensus VDR response element derived from these promoters conforms to a DR-3-type response element (Figure 5) and is recognized by VDR/RXR heterodimers. Another type of VDR response element is that found in the osteocalcin gene, which is composed of a DR-6 motif and apparently confers vitamin D inducibility by VDR homodimers alone. VDR has also been identified in hematolymphopoietic tissues and has been shown through vitamin D₃ to influence the differentiation of myeloid cell lineages. These observations suggest that VDR plays a role during macrophage differentiation. Such evidence of a putative involvement of VDR in cellular differentiation is consistent with the fact that vitamin D can inhibit the growth of certain cancer cells *in vitro*.

Thyroid Hormone Receptors

Thyroid hormones (TH), that is, the active compounds L-3,5,3'-triiodothyronine and L-3,5,3',5'-tetraiodothyronine, have substantial effects on both homeostatic and developmental processes. In the adult organism, THs appear to regulate mainly metabolic processes. They have a general stimulatory effect on the metabolism of

proteins, carbohydrates, lipids, hormones, and ion transport in almost all tissues. On the one hand, this is strikingly illustrated by the ability of THs to increase general O_2 consumption and heat production. On the other hand, during fetal and postnatal development, THs play a crucial role in the growth and development of the skeleton and the central nervous system. This is dramatically illustrated by the well-described human TH deficiency disease called cretinism, characterized by mental retardation and skeletal malformations. Three animal models have been utilized to study the molecular mechanisms of thyroid hormone action during development. The most spectacular developmental effect of TH may be the induction of amphibian metamorphosis. THs trigger the complete body reorganization and conversion of most tissues, including formation of novel organs such as limbs, restructuring many organs, and destruction of organs such as the tail through cell death. All of these processes are based on differential gene expression.

One approach to studying the role of THs during amphibian metamorphosis at the molecular level is the isolation of TH regulated genes. It is estimated that there are at least 30 primary TH target genes, which are presumed to be at the top of a gene expression cascade which is responsible for the observed tissue changes. Two thyroid hormone receptor genes ($TR\alpha$ and β), giving rise to four receptor isoforms ($\alpha 1$, $\alpha 2$, $\beta 1$, $\beta 2$) by differential splicing and alternative promoter usage, have been described in several species (Lazar, 1993). $TR\alpha 2$ is a special isoform, since it does not bind TH and it acts as a dominant negative repressor as discussed on p. 280. Differential tissue distribution of these TR isoforms during development suggests that each isoform performs distinct functions, which is currently under investigation, especially during brain development. Two main types of TR response elements (TRE) have been identified in cellular TR target genes (Figure 5). A DR-4 type response element has been found in the rat growth hormone, malic enzyme, and myosin heavy-chain gene. Moreover, an inverted palindrome response element (IP-6) has been described in the myelin basic protein and chicken lysozyme gene. Identification of further TR target genes and their molecular mechanisms of activation by different TR isoforms should provide new insights into how thyroid hormones affect development and homeostasis.

Sex Steroid Hormone Receptors

There are three sex steroid hormone receptors that are each encoded by a single gene: the androgen (AR), estrogen (ER), and progesterone (PR) receptor. Receptor isoforms have been reported for all three receptors. Whereas the structure and function of the two AR isoforms have not yet been analyzed in detail, differential gene activation by the two PR isoforms that vary only in their N-terminal A/B domain, has already been discussed. Whether the two PR isoforms perform different functions *in vivo* is not yet known. Natural abundant ER isoforms from *Xenopus laevis* have been described. Alternative translation initiation from two in frame AUGs of a single mRNA produces two ER isoforms that differ by 41 amino acids

at their N-terminus, as in the case of the PR isoforms. Sex steroid hormones and their receptors are essential for the normal development of the primary and secondary sex characteristics, and for fertility. Thus, they are likely to control cellular proliferation and differentiation during development. In the adult, of course, this is manifested by endometrial renewal during the menstrual cycle or spermatogenesis. Despite these actions on a variety of tissues and at different periods of development, only relatively few sex steroid hormone receptor target genes have been identified and thus, the direct actions of sex steroid hormones at the molecular level are relatively poorly understood.

Several direct ER target genes have been described. Most of our knowledge about the molecular action of ER in activation of gene transcription has been gained from studies of two animal model systems: the induction of the expression of the egg-white protein ovalbumin and the yolk protein vitellogenin in birds and amphibians. This work has led to the discovery of estrogen response elements. The same is not true of estrogen-responsive genes that are involved in the differentiation and growth of female specific tissues. They still remain to be largely identified. New insight into the function of the ER *in vivo* is likely to be provided by the study of the transgenic ER knockout mouse line through targeted homologous recombination (Korach, 1994). Homozygous ER knockout animals are viable and display a normal gross phenotype, i.e. there is no major lack or malformation of tissues. This suggests that the differentiation of primary sex organs during embryogenesis does not depend on ER action, although ER is expressed in early development. However, these animals are infertile, both males and females, and they show several characteristic defects including ovary dysfunction, underdevelopment of mammary glands and low amounts of PR in females, reduced testis and low sperm count in males, and low bone density in both sexes. This mutant mouse line should be a useful model to investigate the role and function of the ER not only in the various female and male target tissues, but also in human diseases that involve the ER such as osteoporosis and breast and endometrial cancer.

AR-induced gene expression has been demonstrated for several prostate and epididymis-specific genes. Analysis of the androgen response elements in these gene promoters revealed the same consensus sequences as found for the glucocorticoid response element. Since the progesterone and mineralocorticoid response elements also contain the same consensus sequence, this raises the question of hormone signaling specificity. There are three main ways of resolving this specificity problem: (1) selective expression of receptors in target cells; (2) selective availability of hormones in target cells, as in the case of glucocorticoids and aldosterone, or (3) specific target gene expression through specific interactions with adjacent transcription factors or with components of the local chromatin structure. Indeed, examples for each case have been reported.

Several GRE containing genes have been shown to be activated by PR. A well-characterized model gene is the mouse mammary tumor virus long terminal repeat (LTR). However, no PR target genes have so far been identified that are

involved, for example, in the observed progesterone actions on cellular growth and differentiation during the menstrual cycle.

The involvement of AR, ER, and PR in cellular proliferation is also supported by the existence of hormone-dependent cancers. Prostate cancer in man, and breast and endometrium cancers in women are among the most prevalent in humans. About half of these cancers are hormone-dependent, and thus are responsive to antihormone treatment. Despite their pivotal role, it is currently not understood how estrogens and androgens regulate proliferation and growth of tumorigenic cells. Direct target genes that are involved in estrogen- or androgen-dependent oncogenesis still await discovery. Thus, it is not known whether the sex steroid hormones are the causative tumor inducers and, if so, how they function in this process. A current model, explaining at least the growth-promoting effect of sex steroid hormones on cancer cells, suggests that the hormones stimulate the synthesis and release of growth factors that act in a para- or autocrine fashion. However, some studies indicate that growth factors are not sufficient and that both sex steroids and growth factors are independently required for growth promotion. Clearly, a better understanding of the oncogenic process is needed, which will likely be achieved through a better understanding of the molecular effects of sex steroid hormone receptors.

Retinoid Receptors

Several retinoic acid derivatives, which are collectively called retinoids and which are metabolites of vitamin A (retinol), are important vertebrate hormones that play crucial roles in cellular differentiation and organ development. A role of vitamin A or metabolites thereof during development has long been suggested by the observation in animals and humans that vitamin A deficiency during pregnancy results in profound tissue malformations of the embryo. Currently, the two most studied retinoid hormones are all-*trans*-retinoic acid and 9-*cis*-retinoic acid. However, other endogenous retinoids such as 3,4-didehydroretinoic acid, 4-oxo-retinoic acid, and 14-hydroxy-4,14-retro-retinol have also been described and may also be biologically important. There is convincing evidence that the effects of retinoids are mediated by specific nuclear hormone receptors of which two types have been cloned: the retinoic acid receptor (RAR) and the retinoid X receptor (RXR). For both types, three subtypes (α , β , γ), each encoded by a different gene, have been described. In addition, several isoforms were found for each subtype, resulting from alternative promoter usage and/or differential mRNA splicing (Leid et al., 1992). RXR binds specifically 9-*cis*-retinoic acid, whereas RAR binds both all-*trans*-retinoic acid and 9-*cis*-retinoic acid. It is notable that the ligand-binding affinity of RXRs (kDa between 14 and 18 nM) is about 20 to 100 times lower than that of RARs and other nuclear receptors such as the ER.

Many studies about the action of retinoids during development were done in the mouse by gene disruption. For instance, disruption of retinoid receptor genes by targeted homologous recombination confirms the crucial role of retinoids in tissue

differentiation and pattern formation during development. These experiments also revealed that there is considerable genetic redundancy among RARs, since homozygous null mutant mice for RAR α 1, which is the predominant isoform, appeared normal. That other RAR isoforms compensate for the loss of RAR α 1 was confirmed by the detection of altered phenotypes in the case of null mutant mice that lacked all RAR α or RAR γ isoforms. These mice in general showed growth deficiency and early lethality, and displayed a number of specific tissue malformations. A more severe effect was observed in null mutant mice for RXR α , which die during embryogenesis, most likely because of heart malformation, resulting in cardiovascular collapse. Whether this observation, in addition to the fact that RXR is the common heterodimer partner of several other receptors, supports the notion that RXRs play a more central role during development than other nuclear receptors remains to be determined.

Besides the study of mice that contain targeted retinoid receptor mutations, other model systems of organ development and cellular differentiation are used to analyze the function of retinoid hormones. One system is the limb development in chicken or limb regeneration in amphibians. Another is the nervous system in early development in mice and amphibians. In these systems, addition of exogenous retinoids profoundly alters normal development, including induction of additional digit formation in the chick limb bud, complete suppression of forebrain structures in amphibian tadpoles, and homeotic changes of mouse hindbrain rhombomeres. To explain the observed effects of retinoic acid in these systems, it has been proposed that it could act as a morphogen, whose concentration gradient within a tissue would specify positional information. However, several experiments on amphibian limb regeneration and chick limb digit formation suggest that retinoic acid does not act simply as a morphogen, but functions as a signaling molecule in the complex temporal and spatial expression of *Hox* genes. *Hox* genes are thought to control the organization and specification of body parts during development (Ragsdale, Jr. and Brockes, 1991; Tabin, 1991). As might be expected, retinoic acid response elements have been identified in the *Hoxb-1* gene, demonstrating the direct regulation of genes that are important for developmental patterning by retinoid receptors.

In the adult organism, retinoids play a role in the control of the differentiation of epithelia and hematopoietic cell lineages. Furthermore, retinoids have been shown to induce differentiation of certain embryonic carcinoma cell lines, which suggests their potential use in anticancer treatment. It is noteworthy that retinoids can either induce or repress cellular differentiation, depending on the tissue. For example, retinoids inhibit terminal differentiation of epidermal keratinocytes, whereas they induce differentiation of embryonic carcinoma and promyelocytic leukemia cell lines. Regulation of genes that are involved in cellular proliferation, such as *jun* and *fos* and downregulation of their target genes by RAR may be one of the molecular mechanisms involved. It is conceivable that differential expression of the various retinoid receptors and isoforms, and the interaction with other hormone signaling pathways determines cell-specific responses. In summary, then, retinoid receptors

exist in a multitude of receptor subtypes and isoforms and mediate diverse effects of retinoids on tissue differentiation and organ development.

Orphan Receptors and Insect Nuclear Receptors

Since the cloning of the first orphan receptors, the ligand, in the case of RXR, or at least activators, in the case of PPAR, could be identified. However, for most of the other orphan receptors no ligands are known yet. Nevertheless, it is likely that many of these receptors are involved in unknown hormone signaling systems. Alternatively, some orphan receptors may function as ligand-independent constitutive activators or repressors of gene expression. The following paragraphs provide current knowledge of the various orphan receptors in order to give some hint about their function. Many nuclear hormone receptors have also been found in insects, especially in the fruit fly *Drosophila melanogaster*. Some of these insect receptors are highly similar in sequence to certain vertebrate receptors, and thus they are considered receptor homologues (Figure 3). In certain cases, this is further supported by functional homologies as will be discussed below. Given the fact that nuclear hormone receptors have been conserved during evolution (Figure 4), the analysis of insect receptors is likely to provide important clues about the function of homologous receptors in vertebrates, and thus they are discussed together with their vertebrate homologues.

To date, the ecdysone receptor (EcR) is the only insect nuclear hormone receptor with an identified ligand. Ecdysone is a steroid hormone that triggers the molting and metamorphosis of insect larvae. Interestingly, EcR binds to its DNA response elements as a heterodimer with the insect orphan receptor *usp* (ultra spiracle), in a manner similar to several vertebrate receptors which bind to their response elements as heterodimers with RXR (Figure 5). EcR/*usp* heterodimerization increases the affinity for ecdysone, which in turn stabilizes the heterodimer. *usp* and RXR are homologues, which suggests that receptor heterodimerization has been conserved during evolution. This emphasizes the biological importance of this mechanism.

Seven-up (*svp*) is another *Drosophila* receptor, which has vertebrate homologues. They are COUP-TF, ARP-1, ear-2, and *svp46*. Genetic analysis in *Drosophila* indicates that *svp* is involved in the development of the central nervous system and the correct formation of photoreceptors in the eye. Thus, the two zebra fish *svp* homologues (*svp44* or COUP-TF, and *svp46*) are also predominantly expressed in the developing central nervous system, including the areas of the eye rudiments. This implies that some functional aspects of these receptors have been conserved during evolution. ARP-1, ear-2, and COUP-TF also appear to be involved in the regulation of lipoprotein metabolism, since they repress the transcription of certain apolipoprotein genes. In addition, COUP-TF, which has first been identified as chicken ovalbumin upstream promoter transcription factor, appears to function as a broad range gene repressor, because it inhibits transcriptional activation by several other nuclear hormone receptors. Furthermore, differential expression of ARP-1

and COUP-TF indicates that they may also play a role during development of the nervous system (Qiu et al., 1994).

E75, RevErb α (also called ear-1), and RevErb β (also called RVR or BD73) are another pair of insect/vertebrate receptor homologues (Figure 3). Expression of E75 is induced by ecdysone during *Drosophila* metamorphosis. Little is known about RevErb α , which is expressed in muscle, brown fat, and brain, and RevErb β expressed in the nervous system. A particularity of rat and human RevErb α is its genomic organization. There is an overlap of the 3' end of the RevErb α gene with the 3' end of the TR α gene, which are transcribed from opposite strands. Thus, it is conceivable that there may be mutual squelching of transcription between the two genes through the formation of RNA hybrids.

FTZ-F1 and the related insect receptor DHR39 (also called FTZ-F1 β) are implicated in the activation of the homeotic gene *fushi tarazu*, and thus appear to be involved in *Drosophila* embryogenesis and development. Three FTZ-F1 related receptors have been cloned in vertebrates: ELP, LRH-1, and SF-1 (also called Ad4BP). ELP and SF-1 are isoforms resulting from the same gene. For LRH-1, only its strong expression in pancreas is known. In contrast, more is known about the function of SF-1. SF-1 refers to steroidogenic factor 1 and it was originally identified as a cell-specific transcription factor that regulates the expression of several genes coding for adrenal steroidogenic enzymes such as steroid hydroxylases and aromatases. In addition to this regulatory role in steroid hormone synthesis, SF-1 is essential for the development of the adrenals, gonads and for sexual differentiation, which was found in mouse SF-1 null mutants obtained by targeted homologous recombination. Homozygous null mutants lacked completely adrenal glands, gonads, and external sexual organs. Only internal female genitalia were observed in both sexes. Furthermore, it has been demonstrated that SF-1 is essential for the expression of the Müllerian inhibiting substance (MIS) gene. MIS is a tumor growth factor β -like hormone that is involved in the repression of the Müllerian ducts, which is a crucial step in testis development. Thus, SF-1 plays a key role in the normal development of the primary male and female gonads (Smith, 1994).

HNF-4 was originally characterized as a transcription factor that participates in the liver-specific expression of genes. Subsequently, a *Drosophila* homologue of this nuclear receptor was cloned and shown to be essential for the development of mid-gut, fat body, and malpighian tubules. This is strikingly similar to the apparent predominant expression and activity of vertebrate HNF-4 in intestine, liver, and kidney in the adult mouse, suggesting that HNF-4 is not only involved in liver-specific gene expression but also in the development of liver, kidney, and intestine.

Similarly, the chicken homologue (Tlx) of the *Drosophila* receptor tailless (tll) has recently been cloned. Tlx is exclusively expressed in the neuroepithelium of the chicken embryonic brain and tll is required for brain development in flies as well as in the development of the larval poles. This suggests that some functions of these receptors have been conserved during evolution.

Several *Drosophila* receptors have been cloned for which no vertebrate homologues have yet been identified. These include E78 and DHR3, two ecdysone induced gene products of unknown function, and also products of the embryonic gonad (egon), knirps (kni), and knirps-related (knrl). In fact, the latter three proteins are distant relatives of nuclear receptors, since they show only similarity to the DNA-binding domain, but not to the ligand-binding domain of steroid and related receptors.

However, several vertebrate orphan receptors have been cloned for which no *Drosophila* homologues are known. One example is the peroxisome proliferator-activated receptor (PPAR) which is activated by natural fatty acids, as well as xenobiotic peroxisome proliferators. Three genes coding for PPAR α , β , and γ have been identified in several species and to date, two isoforms have been demonstrated for PPAR γ . PPARs mediate the induction of several enzymes involved in the mitochondrial, peroxisomal and microsomal oxidation of fatty acids. Furthermore, differential expression of PPARs in adult tissues and during preadipocyte differentiation has been reported. Moreover, PPARs are specific regulators of the adipocyte-specific gene enhancer, aP2. Thus, it would appear that PPARs are important regulators of certain aspects of lipid homeostasis and may play also an important role during adipose tissue development (Keller and Wahli, 1993; Desvergne and Wahli, 1994).

Vertebrate receptors without known insect homologues include NGFI-B (also called nur77) and the related NURR1 (also called RNR-1). These receptors appear to be immediate-early growth response gene products. In regard to NGFI-B, it is rapidly induced by nerve growth factor or membrane depolarization in the rat pheochromocytoma cell line PC12. NURR1 is specifically expressed in regenerating liver, as well as brain. The function of these receptors is poorly understood except for the involvement of NGFI-B in the expression of certain steroidogenic enzymes in the adrenal. Finally, ERR1, ERR2, GCNF MB67, ONR1, RZR α , β (also called ROR), TR-2, TR-4, and UR are vertebrate orphan receptors that have been cloned from different species. Very little functional data about these receptors is available to date.

Dax-1 is a distant variant of vertebrate nuclear hormone receptors. It contains a putative hormone-binding domain E which is most similar to the ligand-binding domain of ear-2. However, domains A–D (Figure 2) are replaced by a novel DNA-binding domain. Other distant nuclear receptor variants (egon, kni, and knrl) have been identified in *Drosophila* as already mentioned. They possess only the DNA-binding domain of nuclear receptors, but not the other domains. Dax-1 has been isolated by positional cloning and shown to be responsible for X-linked adrenal hypoplasia congenita if deleted or mutated. It appears that dax-1 is exclusively expressed in adult adrenals and testis. *In vitro* DNA-binding and cell transfection experiments indicate that dax-1 may function as a repressor of RAR-mediated transcriptional activation by binding competition to the same hormone

response element. No heterodimerization with RAR and RXR could be observed and dax-1 alone did not activate transcription.

DISEASES CAUSED BY NUCLEAR HORMONE RECEPTOR ABNORMALITIES

Subsequent to the cloning of nuclear hormone receptors, different receptor mutants have been isolated from patients suffering from hormone diseases that were suspected to involve hormone receptor abnormalities. Such a class of diseases involves hormonal resistances as listed in Table 2. The term hormone resistance specifically means that the disease is not due to a deficiency of the hormone but rather to failure of the target organ to respond. Initially, mutations in nuclear hormone receptor genes were found by generating genomic or cDNA libraries from patients, followed by screening, isolating, and sequencing of the isolated clones. Today, the rapid detection of various receptor mutations in a large number of patients and control subjects is made possible by the polymerase chain reaction (PCR) technique, which allows DNA amplification from small samples of tissue or cells. Final proof that certain hormone resistance syndromes are caused by receptor defects comes from the study of vitamin D-resistant rickets type II (VDRR II). Molecular studies of this autosomal recessive disease were initiated as the result of the discovery that cultured human dermal fibroblasts derived from skin biopsies expressed vitamin D receptors (VDR). Thus, these cell cultures could be used to analyze VDR function in VDRR II patients and control subjects. Functional assays included the specific induction of the enzyme 25-(OH)vitamin D-24-hydroxylase (24 hydroxylase) by vitamin D₃, binding of radiolabeled vitamin D₃, measurement of receptor concentration by immunochemical techniques, and receptor-DNA interaction.

VDRR II patients of two families were found, whose skin fibroblasts failed to induce the 24-hydroxylase enzyme upon vitamin D₃ treatment, confirming resistance to vitamin D (Hughes and O'Malley, 1991). VDR analysis showed that VDR is expressed in these cells, the size being about 48 kDa, but it had a reduced DNA-binding affinity as assayed by DNA-cellulose affinity chromatography. This suggested that the VDR of these patients had a mutated DNA-binding domain; this was confirmed by cloning and sequencing of the receptors. Single point mutations were found for each family that led to the change of a single amino acid in the two zinc fingers of the DNA-binding domain. Introduction of these mutations into the cDNA of wild-type VDR and analysis of the resulting mutants finally confirmed that these VDR mutants are defective in DNA binding and thus are the cause of vitamin D resistance.

Analogously, defective receptors have been identified as being the cause of other hormone resistance diseases (Table 2). All types of receptor mutations, including complete deletions of the gene, partial deletions, substitutions of amino acids by frame shift, and point mutations are now known. So far, most of the reported

Table 2. Defective Nuclear Hormone Receptors Causing Hormone Resistance Syndromes

<i>Defective Receptor</i>	<i>Resulting Disease</i>	<i>References</i>
AR	Complete androgen insensitivity (CAI) or testicular feminization (Tfm) <i>X-linked recessive</i>	Patterson et al. (1994). <i>Baill. Clin. Endo. Metab.</i> 8, 379–404.
ER	Estrogen resistance	Smith et al. (1994) <i>N. Engl. J. Med.</i> 331, 1056–1061.
GR	Glucocorticoid resistance <i>autosomal recessive</i>	Arai and Chrousos (1994). <i>Baill. Clin. Endo. Metab.</i> 8, 317–331.
TR β	Thyroid hormone resistance <i>autosomal dominant or rarely recessive</i>	Refetoff et al. (1993). <i>Endocrine Rev.</i> 14, 348–399.
VDR	Vitamin D-resistant rickets type II (VDRR II) <i>autosomal recessive</i>	Hewison and O'Riordan (1994). <i>Baill. Clin. Endo. Metab.</i> 8, 305–315.

receptor mutants involve the androgen, glucocorticoid, thyroid hormone, and vitamin D receptors. They are mainly point mutations that lead to single amino acid substitutions or premature termination of the receptor polypeptide chain (for reviews, see Table 2). As for the thyroid hormone resistance syndrome, only TR β but not TR α receptor mutants have been found so far. Furthermore, only one mutant estrogen receptor has been described in a case of estrogen resistance. No mineralocorticoid and progesterone receptor mutants have been reported to date. Reasons for the failure of detection of certain hormone receptor mutants include lethality of mutations that result in defective receptors, genetic redundancy, allowing the functional compensation of defective receptors by intact receptor isoforms, or simply lack of a corresponding well-described clinical hormone resistance syndrome.

Besides allowing the identification of the molecular basis of several hormone resistance syndromes, studies with receptor mutants provide important knowledge about the molecular function of nuclear hormone receptors. For example, receptor mutants that contain amino acid substitutions in the ligand-binding domain reveal the nature and position of amino acids involved in ligand binding. Such data complement site-directed receptor mutational analyses, which due to the very large number of possibilities, cannot generate exhaustive receptor mutations. Furthermore, functional analysis of receptor mutants in commonly used transient transfection assays most likely does not represent all aspects of receptor activity *in vivo*, where the receptor gene and the receptor target genes are in their natural chromosomal environment.

A different class of diseases that can involve mutated nuclear hormone receptors is cancer. Many cases of breast and prostate cancer are sensitive to estrogen and

androgen, respectively. It is thought that hormones, through their specific receptors, stimulate cell proliferation. In these cases the receptors are intact wild-type receptors and hence, respond to antihormone treatment. However, this is not the case with hormone independent cancer, since the mutant receptors that have been isolated are constitutively active. Whether the receptors in the hormone-dependent cancer are involved in the initiation of carcinogenesis is not yet known.

In contrast to this, there is substantial evidence suggesting that mutant RAR is the cause of human acute promyelocytic leukemia (APL) (Mangelsdorf et al., 1994). As has been shown in most cases of APL, there is a reciprocal chromosome 15:17 translocation that results in the aberrant fusion of the RAR α gene with a gene called PML of unknown function. The two resulting abnormal gene products are RAR-PML and PML-RAR. The PML-RAR protein contains most of the wild-type PML and RAR, except for the A/B domain (see Figure 2). Thus, this fusion protein is likely to exert at least certain RAR and PML functions, whereas the small pieces of RAR and PML in the other fusion protein (RAR-PML) are most likely nonfunctional. Indeed, it has been shown that the PML-RAR protein can activate gene transcription in transient transfection assays, demonstrating that the transcription factor function of RAR is intact. The cellular localization of PML-RAR resembles more the punctuate nuclear pattern of wild-type PML than the uniform nuclear distribution of wild-type RAR. It is interesting that treatment of cells with all-*trans*-retinoic acid leads to the disappearance of the PML-RAR nuclear staining. High doses of all-*trans*-retinoic acid are also used to treat APL patients, which results in complete clinical remission through induction of APL cancer cell differentiation. This strongly suggests that the PML-RAR protein blocks normal promyelocytic differentiation, and thus leads to APL. The molecular mechanisms of action may include interference with retinoid signaling pathways due to its ability to form homo- and/or heterodimers with other receptors. Alternatively, the fusion protein could interfere with the endogenous function of wild-type PML. For instance, the PML-RAR protein could act as a dominant negative PML mutant protein, whose activity is regulated by retinoic acid through the RAR protein. In summary, then, defective nuclear hormone receptors have unequivocally been identified as the molecular basis of several hormone-resistance syndromes. Furthermore, mutant and wild-type receptors are implicated in specific cancer diseases, but their causal involvement in most cases remains poorly understood.

CONCLUSIONS AND PERSPECTIVES

Cloning of the receptors of steroid hormones, vitamin D, thyroid hormones, and retinoid hormones has revealed that they all have the same structural and functional organization. These receptors are transcription factors that control the activity of genes in a hormone-dependent way, thus confirming the concept that the primary effect of these hormones is the regulation of gene expression. Mutational analysis has shown that the receptors comprise several protein domains that perform distinct

functions such as DNA binding or ligand binding. Some receptor functions, for example, DNA binding, are well understood and the three-dimensional structure of the implicated protein domain has been solved, whereas other functions, like ligand binding or activation of gene transcription, are not yet known in sufficient detail. With regard to the physiological and pathophysiological effects of steroid and related hormones, only relatively few target genes have been described so far. Further identification and cloning of target genes is required for a more complete understanding of the role of hormones during development and in the adult. In addition to the receptors with a known ligand, there is a large and increasing number of related receptors for which no ligands have been identified so far. These receptors are referred to as orphan receptors. The function of most of them is not known. However, in some instances, ligands have been found. This encourages the view that many novel hormone signaling pathways will be uncovered in the near future. To some extent, studies with insects and other species are valuable for determining the function of homologous orphan receptors in vertebrates. Finally, there is increasing evidence of interaction between different nuclear hormone receptor signaling pathways. It is thus likely that much more signaling cross-talk with hormones acting through membrane receptors will be found.

ACKNOWLEDGMENTS

We are grateful to B. Desvergne, P. Devchand and N. Mermod for helpful comments and critical reading of the manuscript.

REFERENCES

- Baniahmad, A., & Tsai, M.-J. (1993). Mechanisms of transcriptional activation by steroid hormone receptors. *J. Cell. Biochem.* 51, 151–156.
- Bourguet, W., Ruff, M., Chambon, P., Gronemeyer, H., & Moras, D. (1995). Crystal structure of the ligand-binding domain of the human nuclear receptor RXR- α . *Nature* 375, 377–382.
- Burns, K., Atkinson, E.A., Bleackley, R.C., & Michalak, M. (1994). Calreticulin: from Ca²⁺ binding to control of gene expression. *Trends Cell Biol.* 4, 152–154.
- Clever, U., & Karlson, P. (1960). *Exp. Cell. Res.* 20, 623–626.
- Dedhar, S. (1994). Novel functions for calreticulin: interaction with integrins and modulation of gene expression? *Trends Biochem. Sci.* 19, 269–271.
- Desvergne, B., & Wahli, W. (1994). PPAR: A key factor in nutrient/gene interactions. In: *Inducible Transcription* (Baeuerle, P., Ed.), pp. 142–176. Birkhäuser, Basel.
- Evans, R.M. (1988). The steroid and thyroid hormone receptor superfamily. *Science* 240, 889–895.
- Forman, B.M., & Samuels, H.H. (1990). Dimerization among nuclear hormone receptors. *New Biologist* 2, 587–594.
- Freedman, L.P., & Luisi, B.F. (1993). On the mechanism of DNA binding by nuclear hormone receptors: A structural and functional perspective. *J. Cell. Biochem.* 51, 140–150.
- Gilbert, L.I., & Frieden, E. (1981). *Metamorphosis: A Problem in Developmental Biology*. Plenum Press, New York.
- Glass, C.K. (1994). Differential recognition of target genes by nuclear receptor monomers, dimers, and heterodimers. *Endocrine Rev.* 15, 391–407.

- Green, S., & Chambon, P. (1988). Nuclear receptors enhance our understanding of transcription regulation. *Trends Genet.* 4, 309–314.
- Gronemeyer, H. (1991). Transcription activation by estrogen and progesterone receptors. *Ann. Rev. Genet.* 25, 89–123.
- Hughes, M.R., & O'Malley, B.W. (1991). Genetic defects of receptor involved in disease. In: *Nuclear Hormone Receptors: Molecular Mechanisms, Cellular Functions, Clinical Abnormalities* (Parker, M.G., Ed.), pp. 321–353. Academic Press, London.
- Jensen, E.V., & DeSombre, E.R. (1972). Mechanism of action of the female sex hormones. *Ann. Rev. Biochem.* 41, 203–230.
- Keller, H., & Wahli, W. (1993). Peroxisome proliferator-activated receptors. A link between endocrinology and nutrition? *Trends Endocrinol. Metab.* 4, 291–296.
- Korach, K.S. (1994). Insights from the study of animals lacking functional estrogen receptor. *Science* 266, 1524–1527.
- Lazar, M.A. (1993). Thyroid hormone receptors: Multiple forms, multiple possibilities. *Endocrine Rev.* 14, 184–193.
- Leid, M., Kastner, P., & Chambon, P. (1992). Multiplicity generates diversity in the retinoic acid signalling pathways. *Trends Biochem. Sci.* 17, 427–433.
- Luisi, B.F., Xu, W.X., Otwinowski, Z., Freedman, L.P., Yamamoto, K.R., & Sigler, P.B. (1991). Crystallographic analysis of the interaction of the glucocorticoid receptor with DNA. *Nature* 352, 497–505.
- Mangelsdorf, D.J., Umesono, K., & Evans, R.M. (1994). The Retinoid Receptors. In: *The Retinoids: Biology, Chemistry, & Medicine* (Sporn, M.B., Roberts, A.B., & Goodman, D.S., Eds.), pp. 319–349. Raven Press, New York.
- Martinez, E., & Wahli, W. (1991). Characterization of hormone response elements. In: *Nuclear Hormone Receptors, Molecular Mechanisms, Cellular Functions, Clinical Abnormalities.* (Parker, M.G., Ed.), pp. 125–153. Academic Press, London.
- Miner, J.N., & Yamamoto, K.R. (1991). Regulatory crosstalk at composite response elements. *Trends Biochem. Sci.* 16, 423–426.
- O'Malley, B.W. (1989). Editorial: Did eucaryotic steroid receptors evolve from intracrine gene regulators? *Endocrinol.* 125, 1119–1120.
- Orti, E., Bodwell, J.E., & Munck, A. (1992). Phosphorylation of steroid hormone receptors. *Endocrine Rev.* 13, 105–128.
- Power, R.F., Conneely, O.M., & O'Malley, B.W. (1992). New insights into activation of the steroid hormone receptor superfamily. *Trends Pharmacol. Sci.* 13, 318–323.
- Pratt, W.B. (1992). Control of steroid receptor function and cytoplasmic-nuclear transport by heat shock proteins. *Bioessays* 14, 841–848.
- Ptashne, M., & Gann, A.A.F. (1990). Activators and targets. *Nature* 346, 329–331.
- Qiu, Y., Tsai, S.Y., & Tsai, M. (1994). COUP-TF: An orphan member of the steroid/thyroid hormone receptor superfamily. *Trends Endocrinol. Metab.* 5, 234–239.
- Ragsdale Jr., C.F., & Brookes, J.P. (1991). Retinoids and their targets in vertebrate development. *Current Biology* 3, 928–934.
- Renaud J.-P., Rochel, N., Ruff, M., Vivat, V., Chambon, P., Gronemeyer, H., & Moras, D. (1995). Crystal structure of the RAR- γ ligand-binding domain bound to all-trans retinoic acid. *Nature* 378, 681–689.
- Renkawitz, R. (1990). Transcriptional repression in eukaryotes. *Trends Genet.* 6, 192–197.
- Schüle, R., & Evans, R.M. (1991). Cross-coupling of signal transduction pathways—Zinc finger meets leucine zipper. *Trends Genet.* 7, 377–381.
- Schwabe, J.W.R., & Rhodes, D. (1991). Beyond zinc fingers—steroid hormone receptors have a novel structural motif for DNA recognition. *Trends Biochem. Sci.* 16, 291–297.
- Smith, D.F., & Toft, D.O. (1993). Steroid receptors and their associated proteins. *Mol. Endocrinol.* 6, 4–11.

- Smith, M.J. (1994). Turning on sex. *Curr Biol.* 4, 1003–1005.
- Tabin, C.J. (1991). Retinoids, homeoboxes, and growth factors: Toward molecular models for limb development. *Cell* 66, 199–217.
- Wagner, R.L., Apriletti, J.W., McGrath, M.E., West, B.L., Baxter, J.D., & Fletterick, R.J. (1995). A structural role for hormone in the thyroid hormone receptor. *Nature* 378, 690–697.
- Yamamoto, K.R. (1985). Steroid receptor regulated transcription of specific genes and gene networks. *Ann. Rev. Genet.* 19, 209–252.

Chapter 11

Enzyme Modulation of Access to Corticosteroid Receptors

BRIAN R. WALKER, PAUL M. STEWART, and
CHRISTOPHER R.W. EDWARDS

Introduction	298
The Paradox of Renal Mineralocorticoid Receptor Specificity	299
Mechanisms for Aldosterone-Specificity of Mineralocorticoid Receptors	300
Case History: "Apparent" Mineralocorticoid Excess	301
Cortisol Metabolism and Mineralocorticoid Receptor Specificity	302
Congenital 11 β -Hydroxysteroid Dehydrogenase Deficiency	302
Licorice-Induced Hypertension	303
Enzyme-Mediated Receptor Protection	304
Mineralocorticoid Receptor Specificity	304
11 β -Hydroxysteroid Dehydrogenase Outside the Kidney	305
Clinical Impact of 11β-Hydroxysteroid Dehydrogenase	307
Summary	308

Principles of Medical Biology, Volume 10A
Molecular and Cellular Endocrinology, pages 297–310.
Copyright © 1997 by JAI Press Inc.
All rights of reproduction in any form reserved.
ISBN: 1-55938-815-3

INTRODUCTION

Corticosteroid receptors mediate the target organ response to the major products of the adrenal cortex, glucocorticoids (principally cortisol in man), and mineralocor-

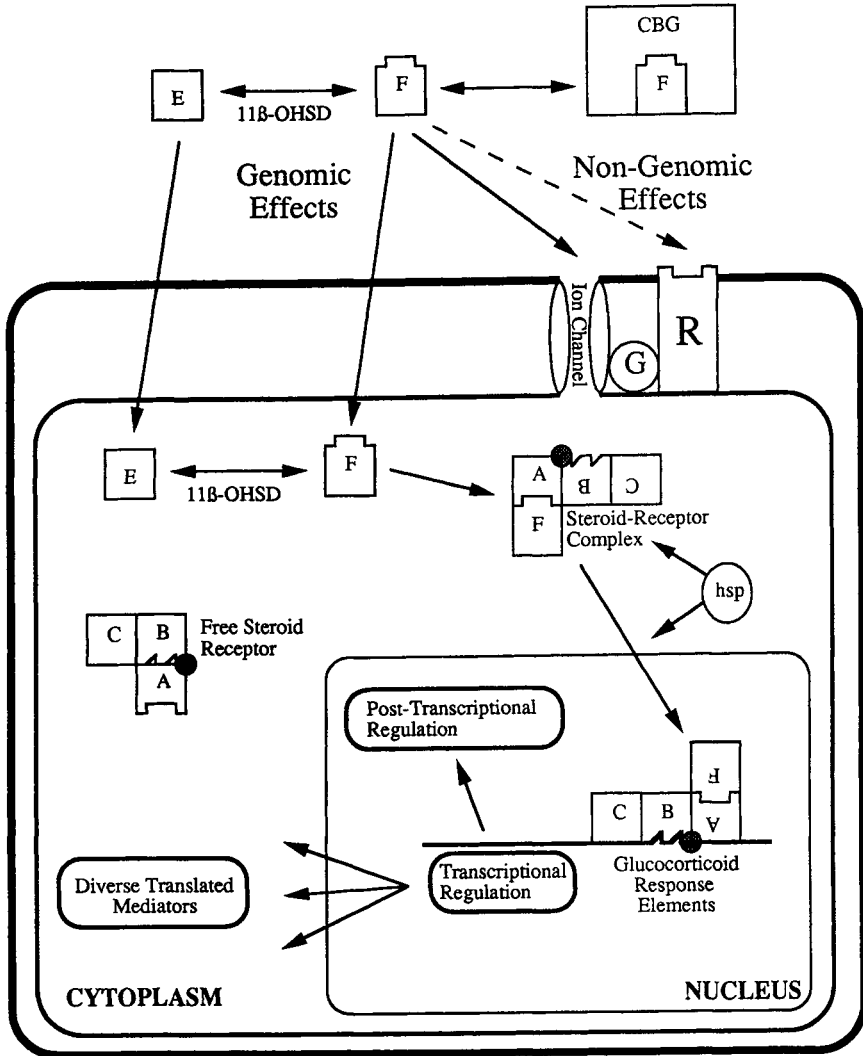

Figure 1. Model for the factors which might dictate sensitivity to cortisol in the target cell. 11β-OHSD = 11β-hydroxysteroid dehydrogenase; A = steroid binding domain; B = DNA binding domain; C = transactivation/immunogenic domain; CBG = cortisol binding globulin; E = cortisone; F = cortisol; G = guanine nucleotide binding protein; hsp = heat shock protein; R = cell surface receptor.

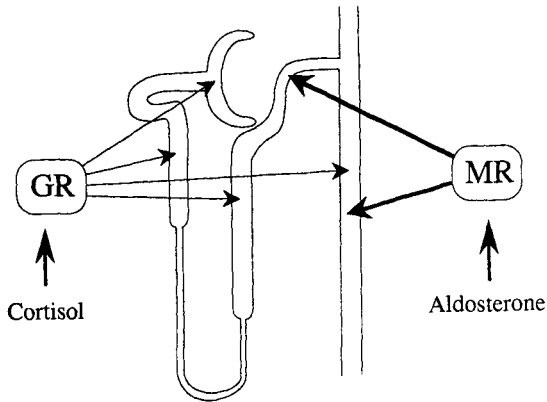

Figure 2. Sites of action of glucocorticoid and mineralocorticoid receptors in the nephron. Note that mineralocorticoid receptors (MR) have a restricted localization to the distal nephron where they are ideally placed to modulate the reabsorption of the 5% of filtered sodium which is not reabsorbed proximally. Glucocorticoid receptors (GR) are, as elsewhere in mammalian cells, ubiquitous.

ticoids (principally aldosterone). They are members of the intracellular receptor superfamily which is highly evolutionarily conserved, and includes receptors for thyroid hormones, vitamin D, sex steroids, and retinoids. Their structure and mode of action is summarized in Figure 1.

Mineralocorticoid receptors form a component of the renin–angiotensin–aldosterone axis. They are expressed in small numbers in a limited number of sites, including distal renal tubules, colon, and sweat glands, where they mediate the characteristic effects of aldosterone on sodium and potassium balance by regulating expression of the $\text{Na}^+\text{-K}^+\text{-ATPase}$. By contrast, glucocorticoid receptors contribute to the response of the hypothalamic–pituitary–adrenal axis. They are ubiquitously expressed in larger numbers, and have more variable effects (e.g. on carbohydrate, lipid, and protein metabolism, on immune function, on behavior, and on the cardiovascular system). These differences are exemplified by the roles of glucocorticoid and mineralocorticoid receptors in the kidney (see Figure 2).

There is preliminary evidence that corticosteroids may also act on cell surface receptors, and this pathway is included in Figure 1. However, the contribution which this response makes to the physiological actions of corticosteroids is unknown.

THE PARADOX OF RENAL MINERALOCORTICOID RECEPTOR SPECIFICITY

In the kidney, aldosterone has well-documented effects, limited to the distal nephron, which mediate sodium retention and potassium excretion. By contrast,

glucocorticoid receptors (GRs) are widely expressed along the nephron and have variable effects on electrolyte handling and glomerular filtration. In *in vivo* binding studies in rodents, it has been shown that the receptors only bind the appropriate ligand, i.e. that mineralocorticoid receptors (MRs) only bind aldosterone and not cortisol (Sheppard and Funder, 1987). Indeed it is vital that this specificity of MRs for aldosterone is maintained, because the circulating free concentrations of cortisol are 2–3 orders of magnitude higher than those of aldosterone, and if MRs did bind cortisol they would be permanently fully activated and there would be no opportunity for physiological regulation.

It seems self-evident that MRs should display specificity for aldosterone. Other members of the intracellular receptor superfamily have ligand-binding domains with highly specific affinity for only one ligand. However, MRs in organs other than the kidney have been shown to bind aldosterone and corticosterone (the major glucocorticoid in the rat) with equal affinity (Krozowski and Funder, 1983). Moreover, when the human mineralocorticoid and glucocorticoid receptors were cloned and expressed, not only did they share remarkable structural homology, but also it was MRs which had the greater affinity for cortisol ($K_d \sim 1$ nM, 10–40 fold higher than the affinity of GRs for cortisol) (Arriza et al., 1987) (Figure 2). Thus, there must exist some alternative mechanism which prevents MRs from binding cortisol *in vivo* in the kidney when the same receptors will bind glucocorticoids *in vitro* and in the hippocampus.

Mechanisms for Aldosterone-Specificity of Mineralocorticoid Receptors

Consider now the possible mechanisms which could confer specificity for aldosterone on intrinsically nonspecific MRs in some cells but not in others, with reference to Figure 1. It could be that:

1. Access of steroids to their target cells is differentially regulated. Approximately 95% of circulating cortisol is bound to cortisol-binding globulin (CBG), while negligible amounts of aldosterone are protein-bound. CBG is too large a protein to cross the capillary basement membrane. It was therefore suggested that CBG might sequester cortisol in the circulation and allow free access for aldosterone (Stephenson et al., 1984). This might not occur in the hippocampus, which is beyond the blood–brain barrier and therefore protected from CBG. Indeed there is some evidence that the dissociation of cortisol from CBG is physiologically regulated, for example by enzymes released during neutrophil activation (Hammond et al., 1990). However, in 10-day-old rats CBG is almost absent from the circulation but renal MRs maintain their specificity for aldosterone (Sheppard and Funder, 1987).
2. Transport of steroids across the cell surface membrane is different for aldosterone and cortisol. Traditionally, we think that steroids are so lipid-soluble that they diffuse readily across any cell membrane. However, recently

- described binding sites for corticosteroids on cell membranes may represent active transport proteins. The significance of these has yet to be established.
3. Access of cortisol and aldosterone to specific intracellular compartments is different. The precise intracellular localization of corticosteroid receptors (CRs) remains controversial. Unlike other members of the superfamily which are exclusively intranuclear, CRs migrate in and out of the nucleus. It may be that their activation occurs in a specific cytosolic site. However, any mechanism by which the steroid ligands could be specifically targeted to the compartment containing the relevant receptors remains speculative.
 4. The molecular events which follow binding of ligand to MRs dictate whether a response occurs to cortisol or to aldosterone. There is a complex series of interactions of CRs with heat shock proteins outside the nucleus and with other nuclear transcription factors which may in part dictate the pattern of binding to hormone response elements on DNA. However, to explain the original data described above on specificity of MRs for aldosterone, a mechanism is required which prevents cortisol not only from inducing a mineralocorticoid response, but also from occupying binding sites on MRs. No molecular interaction which would influence the affinity of MRs for cortisol and not for aldosterone has yet been described.

At this point, the reader may hypothesize other mechanisms to facilitate local preferential binding of aldosterone by MRs which the authors had not considered. However, by contrast with the unsubstantiated speculations above, we have provided data to support a hypothesis which has now withstood critical assessment by several laboratories. This arose from a rare clinical case. Given the background above, the reader should now consider this case history, and see if they arrive at the same conclusions.

Case History: "Apparent" Mineralocorticoid Excess

A 21-year-old male presented in 1984 with severe hypertension (blood pressure 200/145 mm Hg). Plasma electrolytes were as follows: Na 148 mM (normals 135–145); K 1.7 mM (3.5–5.0); HCO_3^- 32 mM (23–28). This profound hypokalemic alkalosis with hyponatremia raised the possibility of excessive activation of MRs, caused most commonly by excessive secretion of aldosterone from a Conn's adenoma or from idiopathic adrenal hyperplasia. Sometimes, a similar biochemical pattern is induced by excessive 11-deoxycorticosterone secretion, for example in congenital adrenal hyperplasia caused by 11 β -hydroxylase deficiency. However, in this patient although supine plasma renin activity was undetectable (consistent with primary mineralocorticoid excess), both plasma aldosterone and 11-deoxycorticosterone were very low. He denied taking any exogenous mineralocorticoids and the cause of his hypertension was a mystery to his attendant physicians.

When he was referred to our clinic we recognized that a similar syndrome had been described before in a handful of children, and designated as the syndrome of "apparent" mineralocorticoid excess (Ulick et al., 1979). There was some evidence that the "missing" mineralocorticoid hormone in these patients' kidneys was cortisol, and we confirmed this by demonstrating that exogenous cortisol dramatically exaggerated our patient's mineralocorticoid excess, while dexamethasone (which activates glucocorticoid but not MRs and suppresses cortisol secretion by suppressing ACTH) reversed the syndrome (Stewart et al., 1988). Thus, in these rare patients, MRs in the kidney appeared to lose their specificity for aldosterone, and were flooded by cortisol.

CORTISOL METABOLISM AND MINERALOCORTICOID RECEPTOR SPECIFICITY

Congenital 11 β -Hydroxysteroid Dehydrogenase Deficiency

During further studies in this patient, we began to appreciate the mechanism whereby cortisol could be activating MRs. It had been observed that these subjects have abnormal metabolism of cortisol. Thus, although circulating cortisol concentrations were normal, urinary free cortisol concentrations were elevated and the ratio of the principal metabolites of cortisol (tetrahydrocortisol and allo-tetrahydrocortisol) to those of cortisone (tetrahydrocortisone) were dramatically increased (see Figure 3) (Ulick et al., 1979; Stewart et al., 1988). This indicated that the enzyme which converts cortisol to cortisone, 11 β -hydroxysteroid dehydrogenase, was deficient.

11 β -Hydroxysteroid dehydrogenase is a microsomal enzyme which was described in the 1950s and for a long time was regarded as one of a number of enzymes which provide routes for hepatic clearance of cortisol from the circulation. However, it is also very active in many other tissues, including the kidney, and has the capacity for conversion of cortisone to cortisol (11 β -reductase activity) as well as cortisol to cortisone (11 β -dehydrogenase activity). These properties suggest that it could play a crucial role in regulating the balance between cortisol (the active glucocorticoid) and cortisone (its inactive metabolite) in different tissues. By contrast, aldosterone is protected from 11 β -dehydrogenase metabolism by its 11-18 hemiacetal structure. On this background, we hypothesized that the physiological role of the enzyme was to protect MRs from cortisol and allow specific access for aldosterone. This function is lost in the syndrome of apparent mineralocorticoid excess, so that cortisol-dependent mineralocorticoid excess ensues.

It would have been difficult to pursue this hypothesis any further without being able to manipulate 11 β -dehydrogenase activity. Fortunately, there were clues in another rare clinical syndrome of mineralocorticoid excess which provided the necessary pharmaceutical tools.

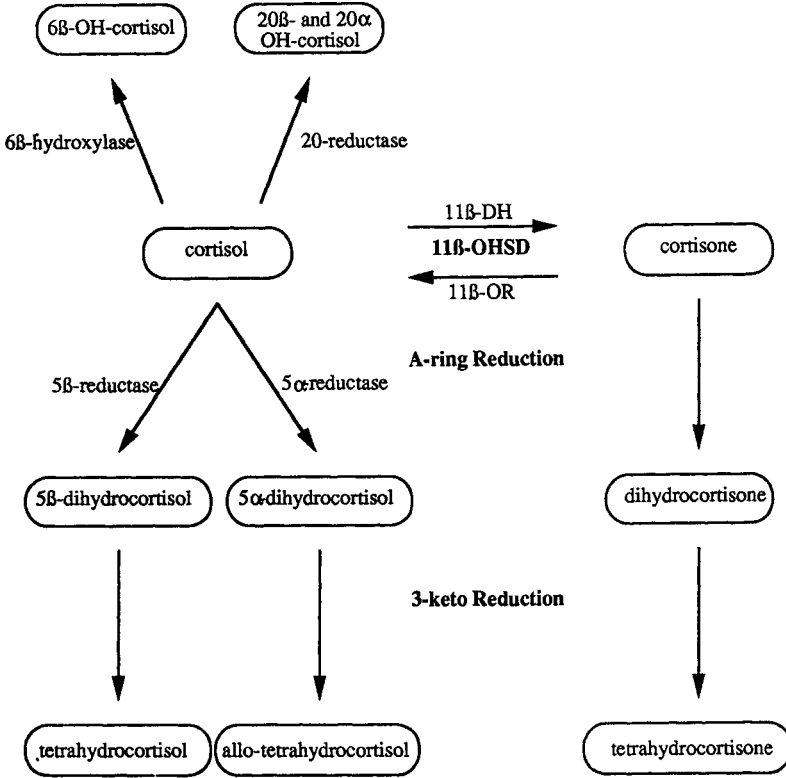

Figure 3. Principal metabolites of cortisol. 11β-OHSD = 11β-hydroxysteroid dehydrogenase; 11β-DH = 11β-dehydrogenase activity; 11β-OR = 11β-reductase activity.

Licorice-Induced Hypertension

Licorice is a sticky black extract derived from the root of the plant *Glycyrrhiza glabra*. It has been used since Egyptian times as a confectionary and medicament, and some individuals habitually consume large amounts of licorice. It is especially effective in the treatment of peptic ulcers. Since the 1940s it has been recognized that licorice induces sodium retention and hypertension. More recently, it has been confirmed that plasma renin activity and aldosterone concentrations are both suppressed by licorice administration. It was assumed that the major constituent of licorice, glycyrrhetic acid, was itself a mineralocorticoid, and this seemed to be confirmed when it was shown to bind to MRs *in vitro* (Armanini et al., 1983). However, more detailed examination of the literature revealed that the effects of licorice are absent in animals and humans without intact adrenal cortices, and can

be reversed by dexamethasone. Also, the affinity of glycyrrhetic acid for MRs was relatively low ($\sim \mu\text{M}$), a concentration unlikely to be achieved *in vivo*.

These observations suggest that licorice administration produces the pharmacological equivalent of the congenital syndrome of apparent mineralocorticoid excess. If so, then might impaired 11β -hydroxysteroid dehydrogenase activity account for cortisol-dependent mineralocorticoid excess in both syndromes? In a study in healthy volunteers, we showed that licorice increases urinary free cortisol while circulating concentrations of cortisol are normal, and increases the ratio of (tetrahydrocortisol + allo-tetrahydrocortisol):tetrahydrocortisone (Stewart et al., 1987). Similar observations followed with the hemisuccinate derivative of glycyrrhetic acid, carbenoxolone (Stewart et al., 1990). Moreover, glycyrrhetic acid and carbenoxolone were shown to be competitive inhibitors of 11β -dehydrogenase activity *in vitro*, with a $K_i \sim 10$ nM.

ENZYME-MEDIATED RECEPTOR PROTECTION

Mineralocorticoid Receptor Specificity

Licorice derivatives provided the tool with which our hypothesis of the mechanism of aldosterone specificity of MRs could be tested. We and others confirmed that MR binding of corticosterone in rat kidney *in vivo* was negligible, but with the addition of licorice derivatives, corticosterone bound to sites normally occupied only by aldosterone (Edwards et al., 1988; Funder et al., 1988). The model for MR specificity illustrated in Figure 4 was therefore confirmed. Indeed, similar observations have been made in relation to MR specificity in toad bladder mucosa, indicating that this mechanism is highly conserved in evolution.

Interestingly, mechanisms for modulating receptor activation by local ligand metabolism appear to operate for all members of the thyroid/steroid receptor superfamily. In relation to other receptors, however, the metabolism usually activates rather than inactivates the ligand. For example, $5'$ -monodeiodinase converts thyroxine to active triiodothyronine, and 5α -reductase converts testosterone to active dihydrotestosterone.

These observations have stimulated intense research activity in a number of laboratories to investigate all aspects of the 11β -hydroxysteroid dehydrogenase enzyme. In this chapter we have selected mainly clinical studies for discussion, but further information can be obtained from the recommended reading list at the end of the chapter. In clinical studies of the enzyme several key issues have emerged: (1) given the ubiquitous distribution of 11β -hydroxysteroid dehydrogenase, including tissues which are not abundant in MRs, does the enzyme modulate access of cortisol to glucocorticoid as well as mineralocorticoid receptors?; and (2) does 11β -dehydrogenase deficiency contribute to pathophysiology in more common forms of hypertension?

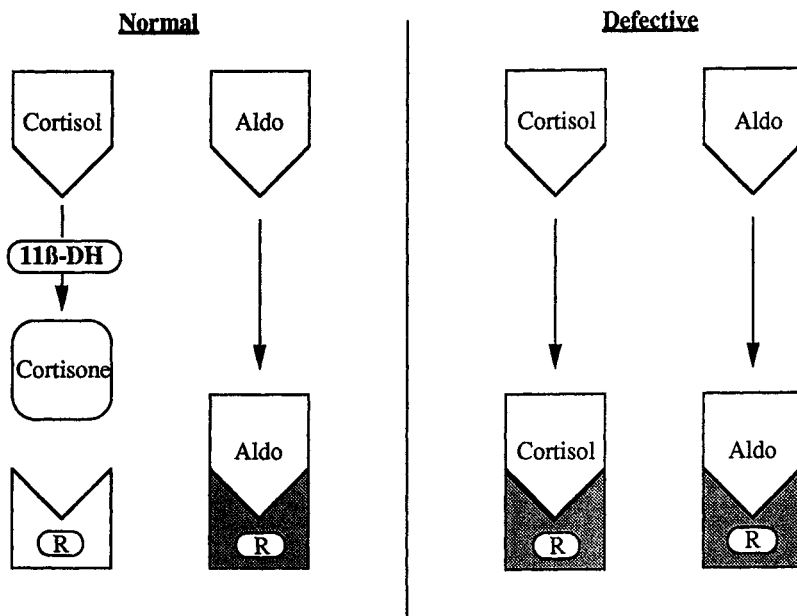

Figure 4. Enzyme-mediated receptor protection in distal nephron.

11 β -Hydroxysteroid Dehydrogenase Outside the Kidney

As discussed above, relatively few organs contain aldosterone-specific MRs. They include sweat glands and colon. In the latter, Na⁺-K⁺-ATPase subunit expression has been shown to be influenced by carbenoxolone, hence it appears that MRs are protected by 11 β -dehydrogenase. However, in many other sites MRs are either not expressed (e.g. liver) or are not specific for aldosterone (e.g. hippocampus). And yet, in all these tissues, 11 β -hydroxysteroid dehydrogenase is expressed in abundance (see Table 1).

Several lines of research illustrate the possible roles of 11 β -hydroxysteroid dehydrogenase in non-aldosterone-specific tissues. It has emerged that the enzyme is expressed as multiple tissue-specific isoforms, transcribed from more than one gene (Brown et al., 1993; Naray-Fejes-Toth et al., 1993). These isoforms are differentially regulated, have different affinities for cofactors and substrates, and perhaps most importantly, result in a different equilibrium between active and inactive glucocorticoid in different tissues. Thus, when we measured cortisol and cortisone in the venous effluent from a variety of human organs, we found that the kidney, as expected, avidly converts cortisol to cortisone, but that the liver has avid 11 β -reductase activity, converting cortisone to cortisol (Walker et al., 1992b). Since the liver is rich in glucocorticoid but not mineralocorticoid receptors, we hypothe-

Table 1. Distribution of 11 β -Hydroxysteroid Dehydrogenase in Mineralocorticoid and Glucocorticoid Target Organs

<i>Mineralocorticoid Targets</i>	<i>Glucocorticoid Targets</i>	<i>Potential Targets for Mineralocorticoids or Glucocorticoids</i>
Distal Renal Tubule	Liver	Hippocampus
Salivary Gland	Lung	Vascular Smooth Muscle
Colon	Testis	Heart
Toad Bladder	Proximal and Distal Renal Tubule	
	Cerebellum	
	Pituitary	
	Epidermis	
	Adipose Tissue	
	Skeletal Muscle	
	Placenta	

sized that the physiological role of hepatic 11 β -reductase might be to maximize the exposure of GRs to cortisol. This makes teleological sense since GRs have lower affinity for cortisol than MRs. We have recently used carbenoxolone to inhibit hepatic 11 β -reductase and observed that, associated with a fall in intra-hepatic cortisol concentrations, hepatic insulin sensitivity increased, consistent with decreased GR activation.

In some tissues both mineralocorticoid and glucocorticoid receptors are expressed, for example in vascular smooth muscle. 11 β -Hydroxysteroid dehydrogenase is expressed in blood vessels. Using the skin vasoconstrictor assay, a bioassay used by dermatologists to compare the relative potency of different GR agonists, we have shown that inhibitors of 11 β -dehydrogenase potentiate the response (Teelucksingh et al., 1990). Moreover, this is associated with increased vasoconstrictor sensitivity to norepinephrine in the brachial artery circulation, an effect of increased CR activation (Walker et al., 1992a). Thus, in this site, 11 β -dehydrogenase is probably the dominant enzyme activity and limits access of cortisol to GRs in a similar manner to the protection it confers on MRs in the kidney.

In the above discussion it is assumed that 11 β -hydroxysteroid dehydrogenase and the target CRs are expressed in the same cells. In one organ, there is evidence for the enzyme modulating access of cortisol to the whole of the circulation. In the intact adult, any effect of 11 β -hydroxysteroid dehydrogenase on circulating concentrations of cortisol is rapidly corrected by hypothalamic-pituitary-adrenal feedback. However, in the fetus, a substantial proportion of circulating cortisol crosses the placenta from the mother, and the fetal hypothalamic-pituitary-adrenal axis is not mature enough to correct completely any change in this supply. 11 β -Hydroxysteroid dehydrogenase is very abundant in the placenta, and may therefore

have a profound influence on fetal exposure to maternal cortisol. Increased glucocorticoid exposure in the fetus can reduce birth weight, and cause hypertension in the adult offspring (Benediktsson et al., 1993). We have demonstrated that carbexolone administration to pregnant rats produces similar characteristics in the offspring, suggesting that placental 11β -hydroxysteroid dehydrogenase has a profound influence on many aspects of fetal maturation.

CLINICAL IMPACT OF 11β -HYDROXYSTEROID DEHYDROGENASE

In the congenital and acquired syndromes of 11β -dehydrogenase deficiency described above, cortisol-dependent mineralocorticoid excess is characteristic. However, given the additional roles of the enzyme in blood vessels and in the placenta, there may be additional routes by which impaired 11β -hydroxysteroid dehydrogenase function may lead to hypertension.

Cushing's syndrome is caused by increased secretion of cortisol. This is commonly associated with a pituitary adenoma secreting ACTH, or with an adrenal adenoma secreting cortisol. Sometimes, ACTH is secreted from other tumors, particularly those of neuro-endocrine or APUD stem cells such as small cell carcinoma of lung. The clinical syndrome of ectopic ACTH secretion can be distinguished from that of other causes of Cushing's syndrome by a high prevalence of hypertension and hypokalemia, i.e. a high prevalence of mineralocorticoid excess. Conventionally, this has been attributed to increased secretion of mineralocorticoids such as 11 -deoxycorticosterone (not aldosterone, which is always suppressed), but there is a poor correlation between the levels of this steroid and the degree of mineralocorticoid excess. A better predictor of hypokalemia is the level of cortisol secretion, which is generally higher in the ectopic ACTH syndrome because ectopic tumors have no GR-mediated feedback suppression of ACTH secretion. However, if cortisol is responsible for the mineralocorticoid excess, then we now know that the barrier presented by 11β -dehydrogenase in the distal nephron would have to be overcome. In patients with ectopic ACTH syndrome we have shown that conversion of cortisol to cortisone is impaired, and that in healthy subjects ACTH exerts an inhibitory effect on 11β -dehydrogenase activity (Walker et al., 1992b). Thus, as well as increasing cortisol secretion rate, ACTH reduces cortisol clearance and increases tissue sensitivity to cortisol. Exaggeration of this phenomenon explains the mineralocorticoid excess of the ectopic ACTH syndrome.

Essential hypertension is a common, but poorly understood, disorder. For every 100 patients diagnosed, we can find a cause for hypertension in fewer than 5. 11β -Dehydrogenase deficiency is a novel mechanism of hypertension, which could explain the disorder in a minority of these patients. We have demonstrated impaired conversion of cortisol to cortisone in about 30% of the small number of patients we have studied (Walker et al., 1993). However, these subjects have normal plasma renin activity and aldosterone concentrations, and therefore do not have any

evidence of mineralocorticoid excess. We are investigating the possibilities that their 11β -dehydrogenase deficiency causes hypertension by increasing vascular sensitivity to cortisol, or that it is a marker for previous placental 11β -dehydrogenase deficiency in these individuals.

There are other clinical syndromes in which 11β -hydroxysteroid dehydrogenase abnormalities have been invoked. For example, the polycystic ovarian syndrome is associated with ACTH-dependent adrenal androgen secretion which may be caused by increased 11β -hydroxysteroid dehydrogenase dependent cortisol clearance (Rodin et al., 1994). Also, in a fascinating observation, Cooke and colleagues have shown that 11β -dehydrogenase activity in cultured lutein-granulosa cells predicts unsuccessful *in vitro* fertilization and reimplantation (Michael et al., 1993).

On this background, it may be that assessment of 11β -hydroxysteroid dehydrogenase activity will become a routine in a variety of clinics.

SUMMARY

11β -Hydroxysteroid dehydrogenase allows individual tissues to respond differently to the same circulating concentration of glucocorticoids. It can both inactivate cortisol by conversion to cortisone, and activate cortisone by conversion to cortisol. Since the free circulating concentrations of cortisol and cortisone are approximately equal, the alterations in equilibrium between the active and inactive steroid dictated by local 11β -hydroxysteroid dehydrogenase activity may have profound effects on the intracellular glucocorticoid milieu. In the near future, tools should become available to allow investigation of the differential regulation of tissue-specific isoforms of 11β -hydroxysteroid dehydrogenase so that we can understand how this novel limb of the hypothalamic-pituitary-adrenal and renin-angiotensin-aldosterone axes exerts its control on the tissue response to corticosteroids. Already, we have evidence that elucidating abnormalities of this mechanism will impact on routine clinical practice.

ACKNOWLEDGMENTS

Our work has been supported by the Wellcome Trust, Medical Research Council, British Heart Foundation, and Scottish Home and Health Department.

REFERENCES

- Armanini, D., Karbowski, I., & Funder, J.W. (1983). Affinity of liquorice derivatives for mineralocorticoid and glucocorticoid receptors. *Clin. Endocrinol. (Oxf.)* 19, 609-612.
- Arriza, J.L., Weinberger, C., & Cerelli, G. (1987). Cloning of human mineralocorticoid receptor complementary DNA; structural and functional kinship with the glucocorticoid receptor. *Science* 237, 268-275.
- Benediktsson, R., Lindsay, R.S., Noble, J., Seckl, J.R., & Edwards, C.R.W. (1993). Glucocorticoid exposure in utero: new model for adult hypertension. *Lancet* 341, 339-341.

- Brown, R.W., Chapman, K.E., Edwards, C.R.W., & Seckl, J.R. (1993). Human placental 11 β -hydroxysteroid dehydrogenase: evidence for and partial purification of a distinct NAD-dependent isoform. *Endocrinology* 132, 2614–2621.
- Edwards, C.R.W., Stewart, P.M., Burt, D., Brett, L., McIntyre, M.A., Sutanto, W.S., DeKloet, E.R., & Monder, C. (1988). Localisation of 11 β -hydroxysteroid dehydrogenase-tissue specific protector of the mineralocorticoid receptor. *Lancet* ii, 986–989.
- Funder, J.W., Pearce, P.T., Smith, R., & Smith, A.I. (1988). Mineralocorticoid action: target tissue specificity is enzyme, not receptor, mediated. *Science* 242, 583–585.
- Hammond, G.L., Smith, C.L., Paterson, N.A.M., & Sibbald, W.J. (1990). A role for corticosteroid-binding globulin in delivery of cortisol to activated neutrophils. *J. Clin. Endocrinol. Metab.* 71, 34–39.
- Krozowski, Z.S., & Funder, J.W. (1983). Renal mineralocorticoid receptors and hippocampal corticosterone-binding species have identical intrinsic steroid specificity. *Proc. Natl. Acad. Sci. USA* 80, 6056–6060.
- Michael, A.F., Gregory, L., Walker, S.M., Antoniw, J.W., Shaw, R.W., Edwards, C.R.W., & Cooke, B.A. (1993). Ovarian 11 β -hydroxysteroid dehydrogenase: potential predictor of conception by in vitro fertilisation and embryo transfer. *Lancet* 342, 711–712.
- Naray-Fejes-Toth, A., Rusvai, E., Denault, D.L., St.Germain, D.L., & Fejes-Toth, G. (1993). Expression and characterisation of a new species of 11 β -hydroxysteroid dehydrogenase in *Xenopus* oocytes. *Am. J. Physiol.* 265, F896–F900.
- Rodin, A., Thakkar, H., Taylor, N., & Clayton, R. (1994). Hyperandrogenism in polycystic ovary syndrome: evidence of dysregulation of 11 β -hydroxysteroid dehydrogenase. *N. Engl. J. Med.* 330, 460–465.
- Sheppard, K., & Funder, J.W. (1987). Mineralocorticoid specificity of renal type I receptors; in vivo binding studies. *Am. J. Physiol.* 252, E224–E229.
- Stephenson, G., Krozowski, Z., & Funder, J.W. (1984). Extravascular CBG-like sites in rat kidney and mineralocorticoid receptor specificity. *Am. J. Physiol.* 246, F227–F233.
- Stewart, P.M., Valentino, R., Wallace, A.M., Burt, D., Shackleton, C.H.L., & Edwards, C.R.W. (1987). Mineralocorticoid activity of liquorice: 11 β -hydroxysteroid dehydrogenase deficiency comes of age. *Lancet* ii, 821–824.
- Stewart, P.M., Corrie, J.E.T., Shackleton, C.H.L., & Edwards, C.R.W. (1988). Syndrome of apparent mineralocorticoid excess: a defect in the cortisol-cortisone shuttle. *J. Clin. Invest.* 82, 340–349.
- Stewart, P.M., Wallace, A.M., Atherden, S.M., Shearing, C.H., & Edwards, C.R.W. (1990). Mineralocorticoid activity of carbenoxolone: contrasting effects of carbenoxolone and liquorice on 11 β -hydroxysteroid dehydrogenase activity in man. *Clin. Sci.* 78, 49–54.
- Teelucksingh, S., Mackie, A.D.R., Burt, D., McIntyre, M.A., Brett, L., & Edwards, C.R.W. (1990). Potentiation of hydrocortisone activity in skin by glycyrrhetic acid. *Lancet* 335, 1060–1063.
- Ulick, S., Levine, L.S., Gunczler, P., Zanconato, G., Ramirez, L.C., Rauh, W., Rosler, A., Bradlow, H.L., & New, M.I. (1979). A syndrome of apparent mineralocorticoid excess associated with defects in the peripheral metabolism of cortisol. *J. Clin. Endocrinol. Metab.* 49, 757–764.
- Walker, B.R., Connacher, A.A., Webb, D.J., & Edwards, C.R.W. (1992a). Glucocorticoids and blood pressure: a role for the cortisol/cortisone shuttle in the control of vascular tone in man. *Clin. Sci.* 83, 171–178.
- Walker, B.R., Campbell, J.C., Fraser, R., Stewart, P.M., & Edwards, C.R.W. (1992b). Mineralocorticoid excess and inhibition of 11 β -hydroxysteroid dehydrogenase in patients with ectopic ACTH syndrome. *Clin. Endocrinol. (Oxf)* 27, 483–492.
- Walker, B.R., Stewart, P.M., Shackleton, C.H.L., Padfield, P.L., & Edwards, C.R.W. (1993). Deficient inactivation of cortisol by 11 β -hydroxysteroid dehydrogenase in essential hypertension. *Clin. Endocrinol. (Oxf.)* 39, 221–227.

RECOMMENDED READINGS

- Edwards, C.R.W., Benediktsson, R., Lindsay, R.S., & Seckl, J.R. (1993). Dysfunction of placental glucocorticoid barrier: link between fetal environment and adult hypertension? *Lancet* 341, 355–357.
- Funder, J.W. (1993). Mineralocorticoids, glucocorticoids, receptors and response elements. *Science* 259, 1132–1133.
- Funder, J.W. (1997). Glucocorticoid and mineralocorticoid receptors: Biology and clinical relevance. *Ann. Rev. Med.* 48, 231–240.
- Monder, C., & Funder, J. (Eds.) (1994). First symposium on 11β -hydroxysteroid dehydrogenase. *Steroids* 59 (2), complete issue.
- Monder, C., & White, P.C. (1993). 11β -Hydroxysteroid dehydrogenase. *Vitamins and Hormones* 47, 187–271.
- Walker, B.R., & Edwards, C.R.W. (1994). Licorice-induced hypertension and syndromes of apparent mineralocorticoid excess. *Endocrin. Metab. Clinics of North America* 23, 359–377.

Chapter 12

Control of Steroid Receptor Function and Gene Expression:

THE GLUCOCORTICOID RECEPTOR

JEFFREY C. WEBSTER and JOHN A. CIDLOWSKI

Introduction	311
Overview of Steroid Receptors	312
Receptors and Response	314
Mechanisms of Resistance	314
Why Intragenic Elements?	317
Summary	318

INTRODUCTION

The glucocorticoid receptor (GR) is the intercellular agent responsible for mediating a plethora of physiological phenotypes in response to secretion of corticosteroids. The importance of glucocorticoids in therapeutic regimes is already widely known in several medical fields. The GR is a well characterized and intensively

Principles of Medical Biology, Volume 10A
Molecular and Cellular Endocrinology, pages 311–320.
Copyright © 1997 by JAI Press Inc.
All rights of reproduction in any form reserved.
ISBN: 1-55938-815-3

studied protein that is an excellent example of a ligand-induced transcription factor. This receptor has been classified both structurally and functionally and belongs to a group of ligand-inducible intracellular receptors which comprise the steroid/vitamin D/retinoic acid receptor superfamily (Evans, 1988; Beato, 1989). We will focus most of our attention on the GR and introduce the reader to several important concepts involving the structure, activation, and autoregulation of the GR. Important information derived for other steroid receptor systems will be included as necessary.

OVERVIEW OF STEROID RECEPTORS

From a historical perspective, the GR was the first member of the superfamily to be cloned and sequenced (Evans, 1988). The subsequent cloning and resultant deduction of amino acid sequences of other steroid receptors revealed several structural commonalities among family members. All of the steroid receptors studied thus far have essentially three separate domains with differing structural and functional properties. The three domains can be roughly divided as follows. The amino-terminal domain is the most variable in amino acid length, ranging from 50 to 500 amino acids among members of this superfamily and is the least conserved domain between family members. Transcriptional activation of gene expression has been linked to this region of the receptor (Hollenberg and Evans, 1988; Kumar and Chambon, 1988). Additional experiments have shown that the amino-terminal domain is the major site of phosphorylation for the GR (Mason and Housley, 1993). However, to date, no function has been ascribed to any of the phosphorylated forms of a steroid receptor. Adjacent to the amino terminal domain resides a short, approximately 70 amino acids, highly conserved region which is cysteine-rich and initially resembled a zinc-finger motif found in the DNA-binding region of the transcription factor TFIIA (Miller et al., 1985). Upon its discovery, this region was immediately attributed the function of a DNA-binding domain of the GR (Evans, 1988). Further studies have revealed that this region is indeed responsible for binding to cognate gene sequences termed "hormone response elements" (Hollenberg et al., 1987). These DNA sequences, when placed 5' to heterologous promoters, have been shown to confer hormone-mediated transcriptional activation when the appropriate steroid receptor is present and is activated by ligand. Recent work suggests that a steroid receptor, once bound to its DNA response element, also interacts directly and/or indirectly with additional components of the basal transcription complex via protein-protein interactions (Beato, 1989). Steroid receptors then function in the context of cooperative combinatorial regulation with other transcription factors. The limits of these interactions are based on the presence of cognate DNA sequences for the various transcription factors, as well as the intrinsic levels of those transcription factors within particular cells. Such combinatorial interactions provide mechanisms for tissue- and cell-type specific gene regulation.

More detailed analyses using NMR and X-ray crystallography of the DNA-binding domain have revealed that the DNA-binding domain resembles a more classical helix-turn-helix motif rather than a zinc finger (Freedman et al., 1988). The carboxy-terminal domain of the receptor is involved in binding ligand (agonist and antagonists). In addition, other investigations have shown that the carboxy-terminal region is also involved in nuclear translocation, trans-activation, interaction with hsp90 and other proteins, and receptor dimerization (Smith et al., 1990). A schematic representation of a generalized steroid receptor is shown in Figure 1. The functional domains described in this figure have been delineated using mutational analysis where truncated receptors have been assessed for their ability to bind to a hormone response element (DNA binding) and their ability to activate transcription using a reporter gene in a transient transfection assay (Hollenberg et al., 1987). Additional investigations have shown that "domain swapping" is possible. As an example, the DNA-binding domains of the estrogen and glucocorticoid receptors were genetically swapped, allowing a ligand-bound estrogen receptor to activate a glucocorticoid-responsive gene (Kumar and Chambon, 1988). These experiments show that a certain structural and functional unity exists between members of the superfamily.

One feature unique to the GR that bears mentioning is the fact that it resides in the cytoplasm in a non-ligand bound state, whereas other members of the steroid receptor superfamily seem to reside in the nucleus. Once hormone is bound to GR, the receptor disassociates from hsp 90 and other ancillary proteins and translocates to the nucleus to carry out various transcriptional effects (Picard et al., 1990; Webster et al., 1994). These studies have elucidated the crucial role that steroid hormone receptors play in hormone-induced transcription. While initial studies revealed that the GR, as well as other members of the superfamily, activate transcription, decreases in gene transcription have also been observed in a number of systems. The underlying mechanisms of these events continue to be an area of intense study.

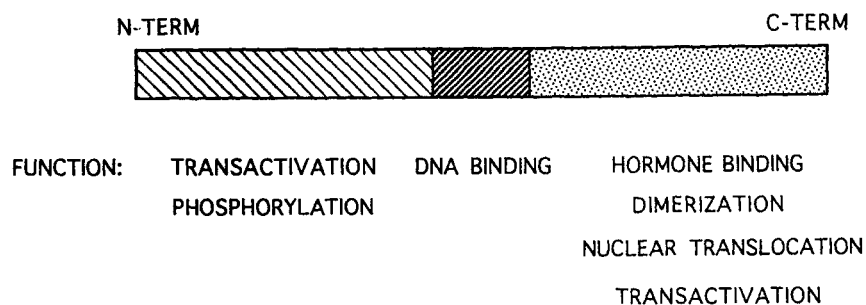

Figure 1. Schematic representation of the glucocorticoid receptor with functional regions listed.

RECEPTORS AND RESPONSE

The regulation of gene expression by steroid hormones is an area of intense medical research because of the role these hormones play in development, differentiation, reproduction, and homeostatic metabolism. The series of events which take place as the result of hormone presentation includes the binding of ligand by the receptor, followed by nuclear translocation and subsequent activity of the receptor/ligand complex as a transcription complex (for a comprehensive review, see Tsai and O'Malley, 1994). The pivotal role that the receptor performs in hormone action is further underscored by physiological studies that reveal a direct correlation between receptor number and cellular responsiveness to hormones. Such a relationship has been clearly demonstrated in a number of cell lines, and intact animals, including humans (for a review, see Bellingham and Cidlowksi, 1988). Thus, the receptors which regulate gene expression are themselves subject to regulation. Tissues and organs then have the ability to adapt or alter responses to hormone during development and differentiation.

MECHANISMS OF RESISTANCE

Attenuated responses to therapeutic hormone administration (steroid resistance) can stem from either genetic (a mutation of a normal receptor) or epigenetic (downregulation of the functional wild-type receptor) causes.

Genetic causes of steroid resistance are rare, but do occur. Examples of familial resistance to corticosteroids have been documented (for a review see Karl and Chrousos, 1993). These cases usually involve a mutation where an incorrect splicing event during RNA processing leads to an aberrant receptor. This mutant receptor is no longer able to bind hormone; therefore, a hormone-resistant phenotype is observed. Most recently, this same group has shown that a frame shift which causes a premature termination of the hGR message has been seen in cases of Nelson's syndrome (Karl et al., 1994). It was noticed that this frame-shift mutation was somatic in nature and only seen in the tumorous cells of the pituitary adenomas. Perhaps more cases of mutant forms of the GR will be documented as molecular techniques are made more readily available to clinicians.

A common epigenetic cause of steroid resistance is hormone-mediated downregulation of the GR. This phenomenon is also common among most of the members of the steroid receptor superfamily except the vitamin D₃ receptor (for a review, see Oakley and Cidlowksi, 1993). Our laboratory (Cidlowksi and Cidlowksi, 1981) and Svec and Rudis (1981) were the first to demonstrate that the GR could be homologously downregulated by prolonged exposure to its own ligand. This process of downregulation was shown to be freely reversible once the ligand was no longer present. Such homologous downregulation, has also been observed with peptide hormone receptors and growth factor receptors (for a comprehensive review see Oakley and Cidlowksi, 1993). This mechanism of autologous downregulation

lation probably reflects a general mechanism to attenuate hormone responsiveness during excess hormone production or therapeutic administration.

One interesting study which bears mentioning is a study where GR levels were examined after extremely long-term hormone treatment of cultured cells (Silva et al., 1994). In this study, HeLa S₃ cells were treated with dexamethasone for up to 2 years. Those cells that were subjected to long-term treatment lost all measurable levels of GR mRNA and protein. However, when hGR cDNA was transiently transfected into these cells, fully functional GR was present. The transiently expressed hGR was even autoregulated when dexamethasone was administered. The most interesting result of this study is that the downregulation of the GR seems to have been altered from an epigenetic event to a genetic form of resistance.

There are several potential mechanisms by which GR could be downregulated in hormone-responsive cells. These potential mechanisms include altering the transcription of the GR gene, a change in the stability of the GR mRNA, or the turnover rate of the mature GR protein. In the past few years, several studies have demonstrated that glucocorticoids markedly decrease GR mRNA levels by 50–80% in a variety of cell types and tissues (Burnstein et al., 1990). Transcriptional analyses, using a nuclear runoff assay, have also shown that a decrease in transcription is responsible for a majority of the reduction in steady-state levels of GR mRNA. However, the precise mechanism responsible for this transcriptional effect remains elusive. Interestingly, the promoter for the GR gene seems to have little or no role in downregulation of this gene. Further, studies have shown that GR has a high affinity towards its own cDNA even under stringent conditions. These investigations involved the use of a Southwestern blotting technique (Silva et al., 1987) where a nuclear protein extract from dexamethasone-treated cells containing endogenous GR is separated on a polyacrylamide gel. After a renaturation step, the proteins are subsequently transferred to nitrocellulose paper and probed with radiolabeled DNA fragments. The GR then appears as a dark spot on an autoradiograph due to the binding of radiolabeled DNA. Furthermore, sucrose density gradient experiments were also able to demonstrate an interaction between GR and its individual cDNA. These observations suggest that there could be elements within the exons encoding GR which are bound by GR and that these elements may be playing a role in glucocorticoid-mediated downregulation of the GR.

To determine if sequences within the GR cDNA were of functional significance in homologous downregulation, our laboratory has expressed functional human GR from its cDNA (driven by an RSV promoter which is not responsive to glucocorticoids) in transiently transfected COSI cells or stably transfected CHO cells. Surprisingly, it was found that the hGR cDNA contains all of the necessary genetic information to achieve downregulation at both the mRNA and protein levels in both the transiently and stably transfected cell lines (Burnstein et al., 1990; Bellingham et al., 1992). This effect was found to be independent of the expression vector used, indicating that the type of promoter has no effect on the downregulation of hGR mRNA. The kinetics of hGR mRNA downregulation were rapid (occurring in

several hours), dose-dependent for dexamethasone, and confined only to ligands of the GR.

An observation that presents an interesting conundrum as to the molecular mechanisms involved in transcriptional downregulation is that the glucocorticoid antagonist RU 486 can also induce hGR mRNA downregulation with the same dose response as dexamethasone (Burnstein et al., 1994). Since RU 486 is a complete antagonist at low concentrations, this finding would suggest that previously proposed models of transcriptional attenuation by steroid receptors may not be applicable to GR downregulation.

The ability of hGR deletion mutants to undergo hormone-mediated homologous downregulation has also been assessed. Using a mutant that has a deleted amino-terminal domain (missing amino acids 9 to 385), it was discerned that the corresponding sequences in the mutant cDNA were not involved in downregulation since this mutant was able to be downregulated to the same extent as wild-type GR in response to hormone. The question arises as to how to study a GR mutant devoid of a hormone-binding domain. To accomplish this goal, both the mutant hGR and wild-type hGR were cotransfected into COS1 cells as previously described. The intact wild-type and mutant hGR steady-state levels were measured by standard Northern blotting assays (Burnstein et al., 1994). Because both the mutant and intact human GR are produced on the same expression vector (which is not regulated by glucocorticoids), this experiment is particularly well controlled since a direct comparison of mRNA transcripts produced in the same cells is possible. It should be noted that with these studies, the mutant GR does not need to be functional or even expressed as the wild-type GR acts as an effector on the mutant GR cDNA. These mutation experiments have shown that DNA binding is a critical step in the downregulation process. Furthermore, if a portion of the ligand-binding domain from amino acids 550 to the C-term end of GR was deleted, this truncation mutant was unable to be downregulated by wild-type GR even in the presence of dexamethasone.

In summary, while the exact mechanisms responsible for ligand-induced downregulation of a cognate hormone receptor are not yet completely understood, there are several interesting insights that can be gained from the results presented above. First, for the GR, only ligands which are capable of binding the GR can mediate downregulation. This includes the antagonist RU 486 which is as effective as dexamethasone in downregulating GR. This indicates that bound ligand is an absolute requirement for the downregulation event and may connote that the GR needs to be in a DNA-binding conformation (nuclear translocated) in order to exert its transcriptional effects on its own gene. That DNA binding to the GR gene by GR is a pivotal event is further demonstrated by the fact that a GR mutant which lacks a DNA-binding domain is incapable of undergoing hormone-mediated downregulation. With the idea that binding to its own gene is a critical event in GR downregulation, the question arises as to where on the GR gene does GR bind to cause downregulation? A large portion of this question is answered by the experi-

ment where the hGR cDNA driven by a non-dexamethasone-responsive heterologous promoter is able to be downregulated in the presence of glucocorticoids. This finding suggests that the hGR promoter and 5' flanking sequences have little impact on receptor downregulation. Additionally, the above experiment also eliminates sequences of the introns from being involved in this process. The intragenic sequences—those that make up the GR exons—are where GR binding is most likely to occur with the resultant effect of downregulation. Current studies are underway to finely map the GR-binding sites on the GR gene. The use of band-shift assays, as well as DNA footprint analysis, will allow us to determine the exact location and nature of the intragenic sequences in hormone-induced autologous downregulation of the GR.

WHY INTRAGENIC ELEMENTS?

Based on our current knowledge of hormone-mediated downregulation of the GR gene, several intriguing questions arise about the biological nature of the downregulation event. The first and most difficult question is, why are intragenic elements conserved in genes? One possible explanation could be that the intragenic elements which mediate the hormone-dependent downregulation of transcription of the GR gene are placed upstream of the GR promoter to overcome certain combinatorial associations of other transcription factors clustered around the promoter. This positioning of the regulatory elements is especially important for the GR which is expressed in a variety of tissues where various tissue-specific factors and other transcription factors can differ from tissue to tissue or cell type to cell type. Therefore, by placing the most crucial regulatory elements of the GR gene in an intragenic region, the regulation of this important gene is universally conserved from tissue to tissue and during development.

There may be an evolutionary advantage to having genetic control elements residing within introns. Presumably, a mutation in the intragenic regulatory elements would also result in a deleterious mutation in the receptor with a concomitant loss of receptor function, resulting in a lethal event. This potential mechanism would thereby preserve the integrity of the regulatory system for GR. Nevertheless, the ability of the intragenic elements to interact with the basal transcription complex of the GR seems to be a dominant event. Figure 2 illustrates a possible model for regulation of the GR. We believe that hormone-bound GR binds to intragenic sequences resulting in an interaction with the GR transcription initiation complex. This interaction causes a diminution in the rate of newly synthesized GR mRNA. On a broader level, these intragenic regulatory elements may allow for acclimatization to a new environmental state. By utilizing the GR in a rate-limiting manner, cells and tissues have a shared avenue available in which to carry out responses to various environmental stimuli.

GR GENE

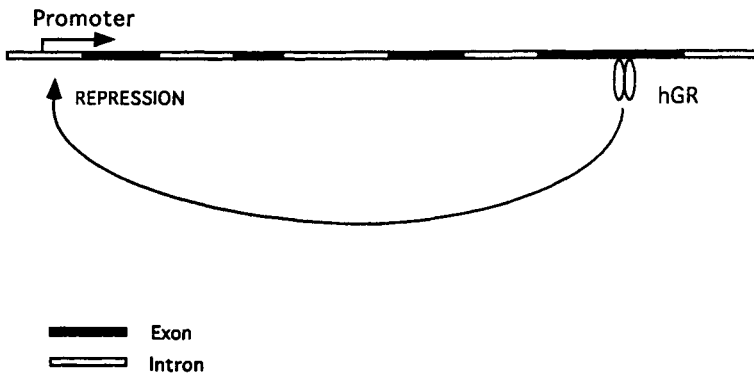

Figure 2. Model of hGR mediated repression of the hGR gene by binding to intragenic sequence.

SUMMARY

To summarize the evidence we have to date on hormone-mediated downregulation and what this may mean for potential avenues of long-term hormone therapy the following points need to be remembered. First, the intracellular concentration of the glucocorticoid receptor is critical in determining the extent of the response to hormone. There is a strong proportional correlation between glucocorticoid receptor levels within a cell and transcriptional activation of a glucocorticoid-responsive gene. Thus, regulation of glucocorticoid receptor levels may be an avenue of modulating cellular responses to glucocorticoids. Our laboratory and others have clearly demonstrated that the glucocorticoid receptor levels decrease upon prolonged exposure to glucocorticoids in cultured cells. This finding supported previous clinical studies where steroid resistance occurred after therapeutic administration of steroid in clinical settings.

The concept of ligand-induced downregulation applies to other steroid receptors as well. This is especially true of the estrogen receptor where an alteration in estrogen receptor levels is seen in a neoplastic state. This ubiquitous nature of hormonal tolerance suggests that a common feedback mechanism is in place which enables a cell to attenuate the continued signal evoked by chronic exposure to ligand. The studies to date show this process to be a complex event with marked differences from transcriptional activation or even other forms of transcriptional repression. For these reasons, the molecular mechanisms which underlie the process of hormone-mediated autologous downregulation of the glucocorticoid receptor will be the subject of intense study with profound clinical benefits.

REFERENCES

- Beato, M. (1989). Gene regulation by steroid hormones. *Cell* 56, 335–344.
- Bellingham, D.L., & Cidlowski, J.A. (1989). The glucocorticoid receptor: functional implications of protein and gene structure. In: *Steroid Receptors and Disease Cancer, Autoimmune, Bone, and Circulatory Disorders* (Sheridan, P.J., Blum, K., & Trachtenberg, M.C., Eds.) pp. 97–119. Marcel Dekker, New York.
- Bellingham, D.L., Sar, M., & Cidlowski, J.A. (1992). Ligand-dependent down regulation of stably transfected human glucocorticoid receptor. *Mol. Endocrinol.* 6, 2090–2102.
- Burnstein, K.L., Jewell, C.M., & Cidlowski, J.A. (1990). Human glucocorticoid receptor cDNA contains sequences sufficient for receptor down-regulation. *J. Biol. Chem.* 266, 7284–7291.
- Burnstein, K.L., Jewell, C.M., Sar, M., & Cidlowski, J.A. (1994). Intragenic sequences of the human glucocorticoid receptor cDNA mediate hormone-inducible receptor mRNA down regulation through multiple mechanisms. *Mol. Endocrinol.* 8, 1764–1773.
- Cidlowski, J.A., & Cidlowski, N.B. (1981). Regulation by glucocorticoids in cultured HeLa S3 cells. *Endocrinology* 109, 1975–1982.
- Evans, R.M. (1988). The steroid and thyroid hormone receptor super family. *Science* 240, 889–895.
- Freedman, L.P., Luisi, B.F., Korszun, Z.R., Basavapp, R., Sigler, P.B., & Yamamoto, K.R. (1988). The function and structure of the metal coordination sites within the glucocorticoid receptor DNA binding domain. *Nature* 334, 543–546.
- Hollenberg, S.M., & Evans, R.M. (1988). Multiple and cooperative trans-activation domains of the human glucocorticoid receptor. *Cell* 55, 899–906.
- Karl, M., & Chrousos, G.P. (1993). Familial glucocorticoid resistance: an overview. *Exp. Clin. Endocrinol.* 101, 30–35.
- Karl, M., Wichert, G.V., Kempter, E., Reincke, M., Moning, H., Ali, I.U., Stratkis, C.A., Oldfield, E.H., Chrousos, G.P., & Schulte, H.M. (1994). Nelson's syndrome associated with a defect in the glucocorticoid receptor gene. 76th Annual Meeting of the Endocrine Society, p. 599.
- Kumar, V., & Chambon, P. (1988). The estrogen receptor binds tightly to its responsive element as a ligand-induced homodimer. *Cell* 55, 361–369.
- Mason, S.A., & Housley, P.R. (1993). Site-directed mutagenesis of the phosphorylation sites in the mouse glucocorticoid receptor. *J. Biol. Chem.* 268, 21501–21504.
- Miller, J., McLachlin, A.D., & Klug, A. (1985). Repetitive zinc-binding domains in the protein transcription factor *Xenopus* oocytes. *EMBO J.* 4, 1609–1614.
- Oakley, R.H., & Cidlowski, J.A. (1993). Homologous down regulation of the glucocorticoid receptor: the molecular machinery. *Critical Rev. Eukaryotic Gene Exp.* 3(2), 63–88.
- Picard, D., Kumar, V., Chambon, P., & Yamamoto, K.R. (1990). Signal transduction by steroid hormones: nuclear localization is differentially regulated in estrogen and glucocorticoid receptors. *Cell Regul.* 1, 291–299.
- Silva, C.M., Powell-Oliver, F.E., Jewell, C.M., Sar, M., Allgood, V.E., & Cidlowski, J.A. (1994). Regulation of the human glucocorticoid receptor by long-term and chronic treatment with glucocorticoid. *Steroids* 59, 436–442.
- Silva, C.M., Tully, D.B., Petch, L.A., Jewell, C.M., & Cidlowski, J.A. (1987). Application of a protein-blotting procedure to the study of human glucocorticoid receptor interactions with DNA. *Proc. Natl. Acad. Sci. USA* 84, 1744–1748.
- Smith, D.F., Schowalter, D.B., Kost, S.L., & Toft, D.O. (1990). Reconstitution of progesterone receptor with heat shock proteins. *Mol. Endocrinol.* 4, 1704–1711.
- Svec, F., & Rudis, M. (1981). Glucocorticoids regulate the glucocorticoid receptor in the AtT-20 cell. *J. Biol. Chem.* 256, 5984–5987.
- Tsai, M.J., & O'Malley, B.W. (1994). Molecular mechanisms of action of steroid/thyroid receptor superfamily members. *Ann. Rev. Biochem.* 63, 451–486.

Webster, J.C., Jewell, C.M., Sar, M., & Cidlowski, J.A. (1994). The glucocorticoid receptor: maybe not all steroid receptors are nuclear. *Endocrine* 2, 967–969.

RECOMMENDED READINGS

- Funder, J.W. (1997). Glucocorticoid and mineralocorticoid receptors: Biology and clinical relevance. *Ann. Rev. Med.* 48, 231–240.
- Oakley, R.H., Sar, M., & Cidlowski, J.A. (1996). The human glucocorticoid receptor β isoform: Expression, biochemical properties, and putative function. *J. Biol. Chem.* 271, 9550–9559.
- Webster, J.C., Jewell, C.M., Bodwell, J.E., Munck, A., Sar, M., & Cidlowski, J.A. (1997). Mouse glucocorticoid receptor phosphorylation status influences multiple functions of the receptor. *J. Biol. Chem.* 272, 9287–9293.

Chapter 13

Molecular Mechanisms of Thyroid Hormone Action

KELLY D. DAVIS and MITCHELL A. LAZAR

Introduction	321
Synthesis, Secretion, and Metabolism of Thyroid Hormones	322
Plasma Binding Proteins	324
Effects of Thyroid Hormones on Metabolic Processes	326
Hypothyroidism	327
Hyperthyroidism	329
The Thyroid Hormone Receptors	329
Generalized Thyroid Hormone Resistance	334
Summary	335

INTRODUCTION

Thyroid hormones exert diverse effects on differentiation, development, and metabolism in virtually every type of vertebrate tissue. The importance of thyroxine (T₄), the principal iodothyronine secreted by the thyroid gland, has been recognized

Principles of Medical Biology, Volume 10A
Molecular and Cellular Endocrinology, pages 321–337.
Copyright © 1997 by JAI Press Inc.
All rights of reproduction in any form reserved.
ISBN: 1-55938-815-3

for decades, and triiodothyronine (T3) was identified as thyroxine's highly active metabolite in the 1950s. Attempts to understand the molecular mechanisms of thyroid hormone action initially focused on plasma membrane, cytoplasmic, and mitochondrial binding proteins, but their affinity for thyroid hormones was low and there was little correlation between binding of hormone and induction of a cellular response to T3. More recently, it has become clear that most of the actions of thyroid hormone are mediated by nuclear thyroid receptors (TRs), which are members of a highly conserved family of receptor proteins. This chapter will focus on thyroid physiology from synthesis and secretion of T3 and T4 by the thyroid gland to its ultimate site of action in the cell nucleus, where it binds to the thyroid hormone receptor and modulates the expression of its target genes.

SYNTHESIS, SECRETION, AND METABOLISM OF THYROID HORMONES

The thyroid gland produces two principal thyroid hormones, thyroxine (T4) and triiodothyronine (T3). T4 is produced exclusively by the thyroid gland, whereas about 20% of T3 in the circulation is produced by the thyroid gland and the remaining 80% is produced from deiodination of T4 in peripheral tissues. The synthesis of the iodine-containing thyroid hormones involves three steps, which are catalyzed by the enzyme thyroid peroxidase. Thyroid peroxidase is a membrane-bound, glycosylated, heme-containing protein with a predicted size of 110 kDa that is most homologous to myeloperoxidase enzyme found in white blood cells (Magnusson et al., 1986). Iodide derived from dietary sources is actively transported from the extracellular fluid into thyroid follicular cells and undergoes *oxidation*. Oxidized iodide is then covalently bound to tyrosine residues of thyroglobulin, a huge dimeric glycoprotein of 660 kDa which is highly abundant in the thyroid's follicular lumen (Vassart et al., 1985). This process is called *organification*. Iodinated tyrosine residues in thyroglobulin are then combined by a process referred to as *coupling* to form iodothyronines: two diiodotyrosines are coupled to form T4, and one monoiodotyrosine is paired with a single diiodotyrosine to form T3. The thyroid gland can store large amounts of thyroid hormones in the follicular lumen as colloid.

Prior to secretion, the follicular cells take up luminal colloid into their cytoplasm by endocytosis. The vesicles then fuse with lysosomes, migrate to the apical membrane, and subsequently undergo pinocytosis.

T4 is the major secretory product of the thyroid gland (see Figure 1 for structures), and essentially serves as a prohormone for T3, which is about 10 times more potent. T4 is relatively long-lived in the serum; its half-life is 7 days. The most important metabolic pathway for T4 is outer ring deiodination to produce the more active thyroid hormone, T3, the major effector of thyroid hormone action inside cells. T3 is also metabolized to other biologically inactive compounds, but this occurs much more rapidly than for T4. As a result, the half-life of T3 is only about 18 hours.

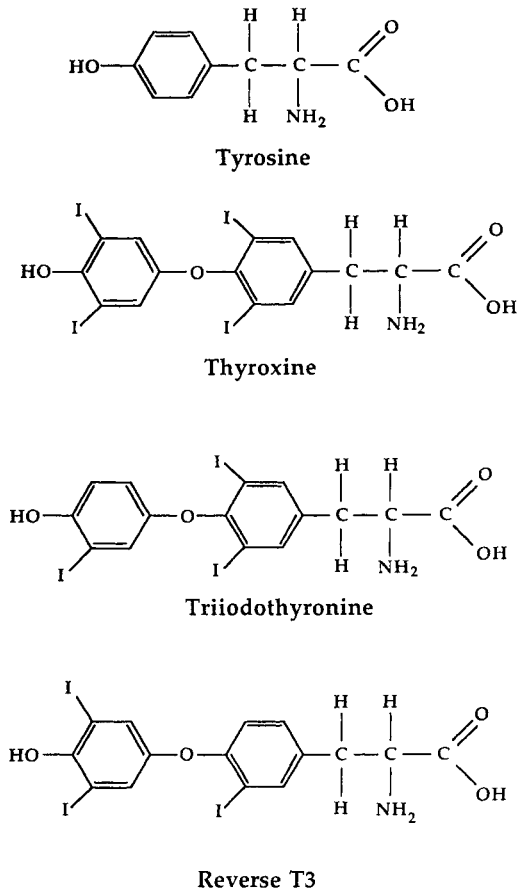

Figure 1. Structures of thyroid hormones and related compounds.

Reverse T3 is produced by inner (tyrosyl) ring deiodination, and this pathway is favored during adverse situations such as starvation and chronic illness. T4 may also be converted to glucuronidated, sulfated, and deaminated metabolites, all of which are biologically inactive.

There are two distinct outer ring deiodinase enzymes which both convert T4 to T3. Type I deiodinase is a selenium-containing enzyme, and is most abundant in liver, kidney, and thyroid (Berry et al., 1991). This deiodinase serves primarily to provide T3 to the plasma. The type II enzyme has a much lower affinity for thyroid hormones, and is present at highest concentrations in brain, pituitary, and brown fat. It is believed to generate intracellular T3 for local use in these tissues. In addition to their unique tissue distribution, the type I and II deiodinases are differentially regulated by thyroid status. Type I is decreased in hypothyroidism and increased in

Table 1. Summary of Properties of the Iodothyronine Deiodinases

	Type 1 5' Deiodinase	Type 2 5' Deiodinase	Type 3 5-Deiodinase
Tissue	liver, kidney, thyroid	CNS, brown fat, pituitary	CNS, skin, placenta
Site of deiodination	outer & inner ring	outer ring	inner ring
Hypothyroidism	decrease	increase	decrease
Hyperthyroidism	increase	decrease	increase
Substrate	rT3 > T4 > T3	T4 ≥ rT3	T3 > T4

hyperthyroidism; the reverse is true for type II. A third enzyme, called 5-deiodinase or type III deiodinase, is responsible for the removal of the iodine groups from the tyrosyl (inner) ring of T3 and T4. This is one of the major routes for inactivation of T4 (to reverse T3) and degradation of T3 to diiodotyrosines. For a summary of the properties of the deiodinase enzymes, see Table 1.

PLASMA BINDING PROTEINS

After synthesis and secretion by the thyroid gland, thyroid hormones are bound to serum proteins for transport to target tissues. The cellular effects of thyroid hormone are mediated by the very small amount of thyroid hormone (<1%) which circulates "free" in the unbound state, and only the free hormone is subject to metabolism. Therefore, the protein-bound thyroid hormones serve as a large reservoir that is slowly drawn upon as the free hormone dissociates from the binding proteins, enters the cell, and is ultimately metabolized. There are three major binding proteins in the plasma: thyroid hormone binding globulin (TBG), thyroxine binding prealbumin (TBPA), and albumin.

Most of the T3 and T4 circulates in the bloodstream bound to TBG. The gene coding for this 54-kDa glycoprotein is located on the X chromosome (Flink et al., 1986). Despite its low concentration in the plasma, it carries ~80% of the bound T4 and 90% of T3 because of its high affinity for the thyroid hormones. TBPA and albumin are present in the plasma at greater concentrations, but bind the thyroid hormones far less avidly than does TBG (see Table 2). A number of conditions can

Table 2. Thyroid Hormone Binding Proteins

	Affinity Constant (M)		Serum Concentration (mg/dL)	Relative Binding	
	T4	T3		T4	T3
TBG	2×10^{-10}	2×10^{-8}	2	80%	90%
TBPA	2×10^{-8}	2×10^{-7}	25	15%	5%
Albumin	2×10^{-6}	1×10^{-6}	4000	5%	5%

Table 3. Alterations in Thyroxine Binding by TBG

<i>Increased</i>	<i>Decreased</i>
Estrogens or Tamoxifen	Congenital
Pregnancy	Nephrotic Syndrome
Hepatitis	Severe Illness
Primary Biliary Cirrhosis	Androgens
HIV Infection	Acromegaly
Congenital	High Dose Glucocorticoids
Acute Intermittent Porphyria	

alter the amounts of thyroid hormone-binding proteins in the plasma, and total serum levels of T3 and T4 are highly dependent upon the amounts of these binding proteins. An increase in the plasma TBG concentration resulting from administration of exogenous estrogen, for example, increases the total T4 as measured in the serum, but does not alter the metabolically important free T4 concentration. See Table 3 for other conditions which affect TBG concentrations in the serum.

The total T4 concentration in the serum is measured by a radioimmunoassay using a highly specific antibody after chemical dissociation from TBG. Measurement of the free T4 concentration is more difficult, expensive, and prone to error because of the tiny amounts present in serum. Because over 99% of the T4 in the serum circulates in the bound form, it is essential to estimate the amount of protein binding of thyroid hormones in addition to measuring the total T4 concentration.

The most widely used test to estimate the number of binding sites for thyroid hormone on the plasma binding proteins is the T3 resin uptake (T3RU). The test is schematically represented in Figure 2. The patient's serum is incubated with radiolabeled T3 and a resin that can bind T3. The amount of radiolabeled T3 bound to the resin is determined by the ability of the proteins in the serum to compete with the resin for T3 binding. The amount of T3 absorbed by the resin is inversely proportional to the number of unoccupied binding sites on the patient's binding proteins, especially TBG. The result of the T3RU test is most often abnormal because of alterations in the total amount of binding protein in the patient's serum or abnormally high or low concentrations of thyroid hormones in the serum. For example, a patient with thyrotoxicosis usually has a high total T4 and T3 RU. The resin uptake is elevated in this case because excessive amounts of T4 bind to many of the sites on TBG leaving little space for any labeled T3, which is subsequently taken up by the resin. A euthyroid patient with congenital deficiency of TBG has a low serum T4 concentration, but the T3RU is high because the radiolabeled T3 has very little TBG to bind in the patient's serum; therefore, most of it binds to the resin. See Table 3 for additional examples of conditions associated with increased or decreased T4 binding by TBG. Note that although radiolabeled T3 is used in this assay for historical reasons, radiolabeled T4 could in principle also be used. It

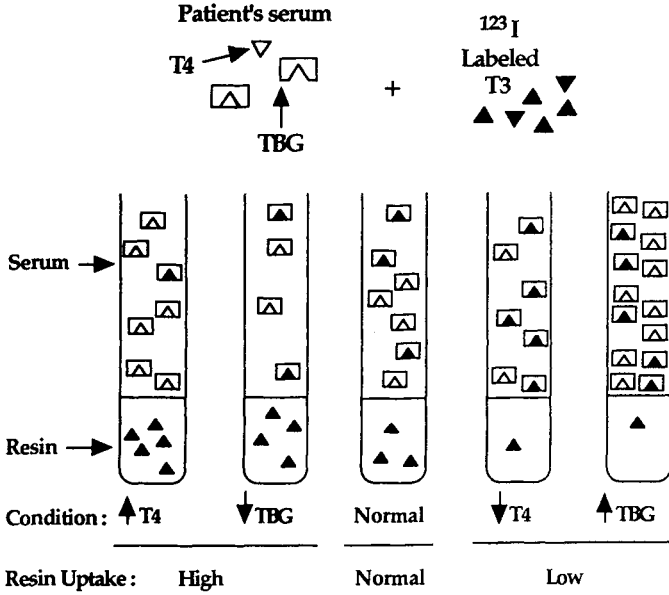

Figure 2. The T3 resin uptake test.

should be emphasized that the T3RU is completely different from measurement of the patient's serum T3 concentration.

Case: A 22-year-old woman in excellent health has a routine physical examination. She has no significant medical history, and her only regular medication is an oral contraceptive, which she has taken for the past year. Thyroid function tests are done as part of the evaluation, and include a serum T4 concentration of 14.7 μg/dl (normal 4.5–11.0), T3RU 19% (normal 25–35%), and TSH 2.0 mIU/ml (normal 0.4–4.0). The physician tells her that she must have the tests repeated because she may be hyperthyroid. Do you agree?

Discussion: A euthyroid patient who is taking estrogen, which increases TBG concentration by changing its glycosylation and prolonging its serum half-life, has a high total T4 concentration, but the T3 resin uptake is low. This is because the radiolabeled T3 binds to the open binding sites on the TBG in the patient's serum, leaving little to bind to the resin. A patient with thyrotoxicosis would have a high T4 and a high resin uptake. The normal TSH provides further evidence that she is truly euthyroid.

EFFECTS OF THYROID HORMONES ON METABOLIC PROCESSES

Thyroid hormones stimulate calorogenesis, reflected by increased oxygen consumption in the whole animal or in isolated tissues studied *in vitro*. The thermogenic

effects of T3 occur in most tissues (except for brain, spleen, and testis) and are roughly proportional to the concentration of TRs in a given tissue. There is a delay of hours to a few days before T3-induced increases in oxygen consumption occur. The increased oxygen consumption is due, in part, to increased Na⁺-K⁺-ATPase activity, which in turn is caused by a two- to threefold induction in the mRNAs for the α- and β-subunits of Na⁺-K⁺-ATPase. Stimulation of this enzyme's activity could account for large increases in thermogenesis due to mitochondrial rephosphorylation of ADP, but may not explain all of the thermogenic effects of T3. There is also some evidence for direct action of T3 on the mitochondria.

T3 alters the metabolism of proteins, carbohydrates, and fats. Thyroid hormones stimulate synthesis of protein within several hours of their administration. This is primarily the result of tissue-specific transcriptional induction of thyroid-responsive genes, but may also be due to posttranscriptional mechanisms. Thyroid hormones also have important effects on carbohydrate metabolism. T3 increases hepatic glucose production by increasing glycolysis, gluconeogenesis, and glycogenolysis. Insulin degradation rate is also increased by thyroid hormones, which may be responsible for difficulty in controlling the serum glucose in Type I diabetics who develop hyperthyroidism. T3 also enhances lipid synthesis, mobilization, and degradation. Because degradation is stimulated more than production, the net effect is a lowering of serum levels of triglycerides, cholesterol and phospholipids in thyrotoxicosis, and increased lipid concentrations in hypothyroidism.

Many of the effects of thyroid hormone are similar to those induced by catecholamines. Furthermore, the widespread use of β-adrenergic blockade in controlling thyrotoxicosis has led to the belief that the activity of the sympathetic nervous system is increased in hyperthyroidism. Careful studies of serum and urinary catecholamines have clearly shown normal levels in hyperthyroidism, while the levels of norepinephrine are elevated only in hypothyroidism. However, thyroid hormones do alter the levels of catecholamine receptors, which may increase sensitivity to catecholamines in hyperthyroidism. In this condition, there is a reduction of α-adrenergic receptors in the heart, and an increase in β-adrenergic receptors in myocardium, adipose tissue, skeletal muscle, and lymphocytes. Thyroid hormones may also affect sensitivity of the tissues to catecholamines at a postreceptor site, or simply have direct effects which mimic the actions of catecholamines.

HYPOTHYROIDISM

Hypothyroidism is a clinical syndrome resulting from deficiency of thyroid hormone, the manifestations of which are highly variable, depending upon the duration and severity of hormone deficiency. In general, hypothyroidism in the 1990s is recognized in many patients with vague or mild symptoms because of the widespread availability of accurate methods for measurement of serum T4 and, even more importantly, TSH concentration. Hypothyroidism may result from a defect at

any level of the hypothalamic–pituitary–thyroid axis, but usually the thyroid itself is at fault, and this is called primary hypothyroidism. Discussion of causes of hypothyroidism is beyond the scope of this chapter, but can be found in references which deal with pathophysiology listed at the end of this chapter.

Hypothyroidism in infancy and childhood results in slowing of normal growth and development. Widespread neonatal screening is performed in the United States because early identification and treatment is essential in order to prevent the mental retardation characteristic in severe cases (cretinism). In adults, many of the common symptoms of hypothyroidism are nonspecific; that is, they are present in many euthyroid patients. Therefore, accurate assays to definitively determine the serum concentrations of T4 (low) and TSH (high if the pituitary responds normally to impaired thyroid function) are crucial for making a diagnosis of hypothyroidism. The symptoms of hypothyroidism are fatigue, cold intolerance, weight gain, constipation, muscle cramps, depression, and menstrual irregularities. Physical findings may include dry skin, puffiness of the hands and face, bradycardia, and delay in the relaxation phase of the deep tendon reflexes. Rarely, very severe prolonged deficiency of thyroid hormone can result in coma and even death. The most pronounced histologic abnormality in hypothyroidism is accumulation of glycosaminoglycans such as hyaluronic acid in interstitial tissues. These hydrophilic substances cause edema which is especially prominent in the skin and cardiac and skeletal muscle.

Case: A 50-year-old woman presents with a 6 month history of fatigue and depression. She also describes extreme dryness of her skin, cold intolerance, myalgias, and constipation. On examination, her BP was 145/90 mm Hg and her pulse was 72 beats/min. Her hair and skin were dry, and she had periorbital puffiness. Her thyroid was not enlarged. The relaxation phase of her deep tendon reflexes was markedly delayed. Except for 1+ nonpitting edema of the feet and ankles, the remainder of her exam was normal. Thyroid function tests were performed, and revealed a serum T4 concentration of 3.2 $\mu\text{g/dL}$ (normal 4.0–11.0), T3 resin uptake 21%, and TSH 52 mIU/mL (normal 0.4–4.5). Other routine laboratory tests were normal except for a serum cholesterol of 312. What is the diagnosis?

Discussion: The patient has fatigue, depression, dry skin, cold intolerance, and constipation, all symptoms which suggest hypothyroidism. The hypertension likely results from the elevated levels of norepinephrine characteristic of this disorder, while edema, myalgias, and delayed reflexes are probably caused by accumulation of glycosaminoglycans in the connective tissue. The thyroid function tests verify the diagnosis of primary hypothyroidism; clearly, thyroidal production of T4 and T3 is the problem, because the pituitary has recognized the serum levels as low and increased synthesis and secretion of TSH. Hypercholesterolemia is common in moderate to severe hypothyroidism because of the effects of thyroid hormone on lipid metabolism. All of the symptoms of hypothyroidism are reversible after treatment with exogenous T4.

HYPERTHYROIDISM

Hyperthyroidism or thyrotoxicosis is the clinical syndrome resulting from excessive amounts of circulating thyroid hormones in the blood. Thyrotoxicosis most commonly results from overproduction of T4 and T3 by the thyroid gland itself, and only rarely is due to excessive secretion of TSH by the pituitary. As a result, serum levels of T4 and T3 are elevated and the normal pituitary responds to the high levels of thyroid hormones by shutting off TSH secretion.

Because thyroid hormones act in virtually every tissue, the manifestations of thyrotoxicosis affect multiple organ systems, and reflect a general acceleration of metabolic processes. Symptoms of hyperthyroidism include nervousness, insomnia, increased sweating and heat intolerance, weight loss despite a normal appetite, palpitations, hyperdefecation or diarrhea, fatigue, and mood changes. Physical examination may reveal thyroid enlargement, tachycardia, tremor, stare, smooth warm skin, atrial fibrillation, and hyperreflexia. Very severe thyrotoxicosis may be life-threatening due to hyperthermia and cardiac arrhythmias, and is referred to as “thyroid storm”.

Case: A 30-year-old woman seeks medical attention because of a 3 month history of palpitations, nervousness, heat intolerance, oligomenorrhea, and 10 pound weight loss. On physical examination, her blood pressure was 130/85 mm Hg and her pulse was 120 beats/min. She appeared restless and had a tremor of her hands, as well as lid lag and stare. Her thyroid gland was symmetrically enlarged, and there was a prominent bruit. Her mother and maternal aunt had been treated for hyperthyroidism in the past. Laboratory studies showed a serum T4 concentration of 17.6 µg/dL (normal 4.5–11.0), T3 resin uptake 40% (normal 25–35%), and TSH <0.1 uIU/mL (normal 0.4–4.0).

Discussion: The palpitations, nervousness, lid lag, and stare observed in this young woman are typical of the effects of increased sensitivity of the sympathetic nervous system in hyperthyroidism. Weight loss and heat intolerance are the result of increased calorogenesis and heat production stimulated by excessive thyroid hormones. The thyroid bruit reflects increased blood flow through the gland, while thyroid enlargement is common in some pathologic states associated with hyperthyroidism. Hyperthyroidism is more common in women than in men, and tends to run in families. The laboratory studies show increased serum concentrations of T4 and T3 and an elevated T3 RU (most of the sites on TBG are occupied by the patient's T4, leaving more labeled T3 for uptake by the resin). The low TSH represents an appropriate response by the pituitary gland, which senses that the serum T3 and T4 levels are too high.

THE THYROID HORMONE RECEPTORS

Thyroid hormones act inside of cells, primarily in the cell nucleus (Figure 3). They are similar in this way to steroid hormones, but are unlike peptide hormones which

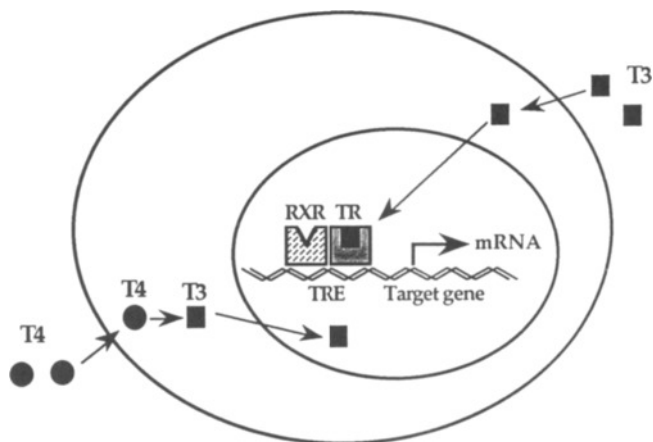

Figure 3. Schematic of the cellular actions of thyroid hormones. T4 and T3 enter the cell by diffusion. The TR is shown here as a heterodimer with RXR, but may also act as a homodimer. T3 binding results in increased or decreased transcription (arrow) of specific target genes.

interact with receptors located on the cell surface. Free T3 and T4 enter the cell by diffusion. Once in the cytosol, some of the T4 may be deiodinated to form T3, which enters the nucleus either by passive diffusion or via a transport mechanism in the nuclear membrane. In the cell nucleus, T3 interacts with chromatin-associated thyroid hormone receptors (TRs), which are hormone-dependent transcription factors. The TR has two important properties: (1) it must bind T3 with high affinity and specificity, and (2) recognize, bind to, and regulate the transcription of specific T3-responsive genes.

Prior to the cloning of the TRs, it was known that most mammalian cells contained several thousand chromatin-associated nuclear receptors, each with a molecular weight of approximately 50,000, that were capable of binding thyroid hormone with high affinity ($K_d 10^{-10}$ M) (Samuels, 1983; Oppenheimer et al., 1987). In 1986, the nuclear thyroid hormone receptor was cloned and found to resemble receptors for steroid hormones (Sap et al., 1985; Weinberger et al., 1985). The proteins all contain a central DNA-binding domain (DBD) containing basic amino acid residues, as well as two zinc-finger structures formed by two groups of four cysteine residues held in a tetrahedral arrangement by a central zinc atom (Figure 4). They also contain less well-conserved carboxy-terminal ligand-binding domains (LBD). This structural organization is the paradigm of the thyroid-retinoid-steroid receptor family of ligand inducible transcription factors (Evans, 1988).

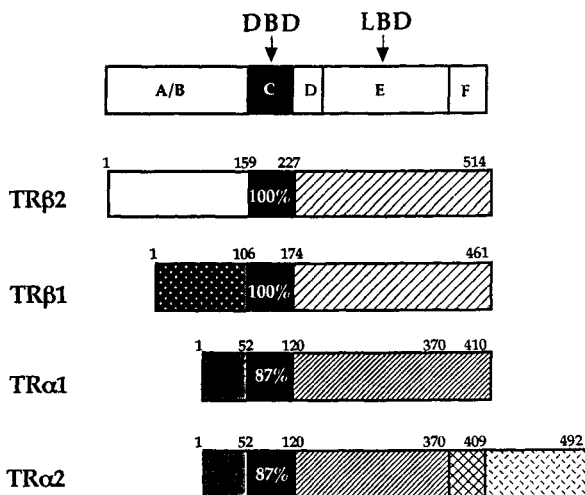

Figure 4. Multiple thyroid receptor isoforms. A prototypical nuclear hormone receptor is depicted at the top, showing domains A–F. Percent amino acid identity of the DNA binding (C) domain is indicated. Identical amino acid sequences are indicated by identical patterns. Highly homologous sequences in TRα and TRβ are depicted by similar patterns (*diagonal stripes*).

Cloning of TR isoforms in multiple species has indicated the existence of two TR subtypes, encoded by separate genes, located on human chromosome 17(α) and 3(β). Two TRα isoforms, α1 and α2, are generated by alternative splicing. TRα1 and TRα2 are identical for the first 370 amino acids, after which they diverge entirely in the LBD. As a result, TRα2 does not bind T3 (see below). Two additional TRs, TRβ1 and TRβ2, are derived from alternative promoters of the TRβ gene. Thus, TRβ1 and TRβ2 are identical except for the A/B domains, derived from unique 5' exons (Hodin et al., 1989).

The TR isoforms have different patterns of transcriptional and posttranscriptional regulation, which may be developmental, tissue-specific, or hormonally induced. The most dramatically regulated TR isoform is TRβ2. Its mRNA is predominantly expressed in the anterior pituitary gland, and to a lesser degree, in specific regions of the brain including the hypothalamus, as well as in the developing striatum and hippocampus. TRβ2 mRNA is transcriptionally downregulated by T3 in rat pituitary cells. Both its tissue specificity and negative regulation by T3 suggest that TRβ2 may play a role in pituitary responsiveness to thyroid hormones. Furthermore, depletion of TRβ2 mRNA is accompanied by reduced T3-binding capacity and responsiveness to T3.

The other TR isoforms, TRα1, and TRβ1, can be detected in most tissues. TRα1 mRNA is most abundant in skeletal and cardiac muscle and brown fat. TRβ1 is the most evenly distributed in various tissues, but is extremely abundant in liver, kidney,

and brain. TR α 2, the non-T3-binding form of TR α , is highly expressed in brain tissue. Its function is unclear, but TR α 2 might be important in regulating T3 responsiveness due to its ability to block the effects of other TRs by competing for binding to target genes. Both TR α 2 and TR α 1 are modestly downregulated by T3 in most tissues, while TR β 1 is unaffected except in pituitary, where it is induced.

The TRs are ligand-dependent transcription factors, which must translocate to the cell nucleus after their synthesis, specifically bind to T3, and recognize and modulate transcriptional activity of T3 responsive genes. The A/B domains of all the TRs are completely different (see Figure 4). This domain is of unknown function, and can, in fact, be deleted from the TR entirely without affecting its ability to activate transcription in the presence of T3. The nuclear localization signal, comprised by several amino acids in the D domain, is similar to that of other nuclear proteins such as the SV-40 large T antigen. In contrast to the glucocorticoid receptor, which is complexed to heat shock proteins in the cytoplasm in the absence of ligand, the TR is always found in the nucleus closely associated with chromatin.

The C domain (DBD) of the TR is the most related to that of other members of the steroid/thyroid receptor family. Despite the striking similarity of the DBD among various family members, there are differences which are important for DNA-binding specificity. Closely related members, such as TR, retinoic acid receptor (RAR), retinoid X receptor (RXR), and vitamin D receptor (VDR) are most alike in this domain, and they all bind to similar response elements in target genes.

The assay most often used to study DNA binding to response elements (TREs) is an electrophoretic mobility shift assay, in which specific radiolabeled TREs are allowed to bind with TR protein, and run on a nondenaturing gel. After autoradiography, TR-TRE complexes appear as bands which migrate slower in the gel than the TREs alone. The TR can bind to response elements *in vitro* containing the AGGTCA motif, arranged as direct (->...->), inverted (-> <-), or everted (<- ->) repeats. The sequence AGGTCA is referred to as a half-site, and many naturally occurring T3-responsive genes contain two copies of the sequence arranged as an inverted repeat or, as a direct repeat separated by a four base pair spacer (DR4). The length of this spacer is an important determinant of TR specificity (Umesono et al., 1992). The half-sites are often "imperfect", resulting in reduced affinity and perhaps greater opportunity for regulation and binding by heterodimers (see below). The subtleties of the rules governing DNA-binding specificity for the TR is a subject being actively investigated by many laboratories.

In vitro, the TR binds to DNA as a monomer and homodimer but these interactions are relatively weak, due to rapid dissociation of the TR from DNA. The TR forms a much more stable complex with TREs in the presence of other nuclear proteins, originally discovered by adding nuclear extract from liver or HeLa cells to the gel shift assay (Lazar, 1993 and references therein). These nuclear factors have been identified as isoforms of RXR (Kliwer et al., 1991; Yu et al., 1991), another member of the steroid/thyroid receptor family for which the natural ligand

is 9-*cis*-retinoic acid (9-*cis*-RA). RXR is a dimerization partner for the TR which is expressed in virtually all cells. The TR's ability to induce transcription of some target genes is enhanced in the presence of RXR, suggesting that the TR-RXR heterodimer is a preferred mediator of T3 action in the cell. Indeed, T3 actually reduces DNA binding of TR homodimers to some TREs (Yen et al., 1992). When the TR-RXR heterodimer binds to a DR4 response element, mutational analysis indicates that the RXR binds to the upstream (5') half-site, while the TR occupies the downstream half-site (Glass et al., 1993; Perlmann et al., 1993).

Studies using mutant TRs have demonstrated three specific regions which are particularly important for dimerization, shown in Figure 5. Mutations in D domain amino acids of TR β 1 (286–305) not only abolish the TR's ability to dimerize, but also to transactivate, with no significant effect on ligand binding (O'Donnell and Koenig, 1989). Amino acids in the E domain (362–461) are also required for dimerization of TR and RAR (Forman and Samuels, 1990). Interestingly, TR α 2 cannot heterodimerize with other nuclear proteins because it is missing the last few amino acids of this domain. A third region in the second zinc finger determines DNA-binding specificity based upon half-site spacing, but also appears to be a weak heterodimerization domain (Perlmann et al., 1993). At this time, it is unclear whether the domains responsible for homo- and heterodimerization are the same or different.

The ligand binding (E/F) domain is highly homologous among all the TR isoforms, and all bind T3 with a K_d of approximately 10^{-10} M. Binding affinities for various T3 analogues, however, differ slightly from isoform to isoform. TR α 2 cannot bind T3, as previously mentioned, because it lacks amino acids which are necessary for T3 binding. When bound to T3 ("liganded"), the TR can have either

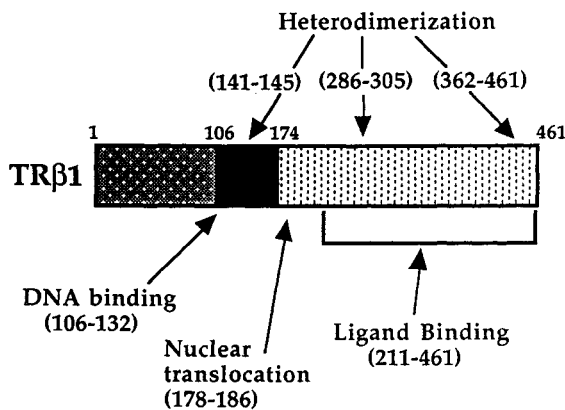

Figure 5. Functional domains of thyroid hormone receptors. Numbering refers to amino acids in TR β 1.

positive or negative effects on the transcriptional rate of a particular gene. Positive TREs include those in genes encoding growth hormone, malic enzyme (involved in fat metabolism), and α -myosin heavy chain (important for cardiac function). All of these promoters contain TREs that resemble a DR4, while the rGH gene contains both a direct and an inverted repeat. Negatively regulated TREs include the rat TSH α - and β -subunits. Because the TREs for TSH α and β are located close to the TATA box, it has been suggested that TR binding interferes with assembly of the transcription initiation complex; however, negative regulation by the liganded TR remains poorly understood. In the absence of T3, the TR acts as a basal repressor of transcription, even of genes which are induced in the presence of T3.

GENERALIZED THYROID HORMONE RESISTANCE

Generalized resistance to thyroid hormone (GRTH) is found in a group of rare clinical disorders characterized by reduced tissue responsiveness to circulating levels of thyroid hormones that would ordinarily be excessive. Patients with GRTH have been described for decades and a defect at the site of hormone action has long been suspected. GRTH is usually inherited as an autosomal-dominant disorder. Since the cloning of the TRs and the availability of molecular techniques for study of these patients, it has been determined that most patients with GRTH have mutations that result in a single amino acid change in the T3-binding domain of one of their TR β gene alleles. The abnormal TRs bind T3 poorly or not at all and cause the syndrome by inhibiting the function of the remaining normal TRs. The dominant inhibition explains the inheritance of the disorder.

The hallmarks of GRTH are elevated serum levels of free T3 and T4, nonsuppressed TSH (because the resistant pituitary fails to respond to high levels of thyroid hormones by shutting off TSH secretion), the absence of manifestations of hyperthyroidism, and thyroid gland enlargement. Symptoms of hypothyroidism are usually minor or even absent, because of the presence of normal receptors competing with the mutant inhibitor. Abnormalities in patients with GRTH are mostly cognitive, especially attention deficit disorder and learning disabilities. A unique kindred of patients with GRTH following an autosomal recessive pattern of inheritance has been linked to large deletions in the TR β gene. Affected homozygotes in the family completely lack TR β and have short stature, sensorineural hearing loss, mutism, bird-like facies, and skeletal deformities. Heterozygotes in this family are completely normal, which further supports the notion that it is not a decrease in receptor number alone that causes hormone resistance in the autosomal dominantly inherited form. Readers are referred to reviews devoted exclusively to the discussion of GRTH and references therein for further information (Usala and Weintraub, 1991; Weiss and Refetoff, 1992). The following case demonstrates some of the clinical features of this disorder.

Case: A 30-year-old man has a routine physical examination for his job. He feels entirely well, his past medical history is completely unremarkable, and he takes no regular medications. He stood 62" tall and weighed 135 pounds. His BP was 120/80 mm Hg and his pulse was 72 beats/min. His thyroid was palpable and estimated to be about twice the upper limit of normal in size. Examination of the heart, lungs, and abdomen was normal. He did not have a tremor, and his reflexes were normal. Routine laboratory tests were significant for a serum T4 concentration of 18.4 $\mu\text{g/dL}$ (normal 4.5–11.0), T3 resin uptake 40% (normal 25–35%), and TSH 3.5 mIU/mL (normal 0.4–4.0). After return of the test results, the company physician questions the patient about symptoms such as insomnia, nervousness, irritability, palpitations, and diarrhea, but he has none of these. He relates that his mother and brother have some type of thyroid condition. The physician repeats the thyroid function tests, the results of which are virtually identical to the first set, measures the concentration of TBG (normal), and orders free T3 and T4 levels, which are both above the normal range. The physician thinks the patient must have a TSH-producing pituitary adenoma, and orders an MRI scan.

Discussion: The patient described above is clinically euthyroid, and has a goiter and short stature. The family history of thyroid disease is consistent with an autosomal dominant pattern of inheritance. The TFTs show increased serum concentrations of total T4, and a high T3 RU, because most of the binding sites on TBG are occupied by the patient's T4. Free hormone concentrations provide further evidence that his serum levels are abnormally high. The two clues to the correct diagnosis, which is GTRH, are the normal TSH concentration (which rules out primary hyperthyroidism) and recognizing the absence of clinical manifestations of thyrotoxicosis. If symptoms are minor, no specific treatment is warranted. However, if the serum concentration of TSH becomes elevated, or symptoms of hypothyroidism are present, T4 should be prescribed.

SUMMARY

Thyroid hormone activity is regulated at many different levels: by feedback mechanisms involving TSH, conversion of T4 to T3 by 5'-deiodinase, and regulation of nuclear TRs, as well as the dominant negative inhibitor, TR α 2. Differences between the TR isoforms and their many potential combinations with a number of heterodimerization partners may help to precisely regulate the diverse effects of T3. The emerging complexity of thyroid hormone synthesis, transport, and function at the molecular level is not surprising given the importance of thyroid hormone in such diverse processes as metabolism, development, and differentiation.

NOTE ADDED IN PROOF

Since this chapter was written, there have been several developments in our understanding of thyroid hormone receptors. The reader is referred to the following two reviews for this information.

- Desvergne, B. (1994). How do thyroid hormone receptors bind to structurally diverse response elements? *Mol. Cell. Endocr.* 100, 125–131.
- Forest, D., Golarai, G., Connor, J., and Curran T. (1996). Genetic analysis of thyroid hormone receptors in development and disease. *Rec. Prog. Hormone Res.* 51, 1–22.

ACKNOWLEDGMENTS

This work was supported by funds from the American Cancer Society, the McCabe Fund, an NIH C. A. P. Award (to K.D.D.), and funds from Knoll Pharmaceuticals and the Lucille P. Markey Charitable Trust (to M.A.L.).

REFERENCES

- Berry, M.J., Banu, L., & Larsen, P.R. (1991). Type I iodothyronine deiodinase is a selenocysteine-containing enzyme. *Nature* 349, 438–440.
- Chatterjee, V.K.K., & Tata, J.R. (1992). Thyroid hormone receptors and their role in development. *Canc. Surv.* 14, 147–167.
- Evans, R.M. (1988). The steroid and thyroid hormone receptor superfamily. *Science* 240, 889–895.
- Flink, I.L., Bailey, T.J., Gustafson, T.A., Markham, B.E., & Morkin, E. (1986). Complete amino acid sequence of human thyroxine-binding globulin deduced from cloned cDNA: close homology to the serine antiproteases. *Proc. Natl. Acad. Sci. USA* 7708–7712.
- Forman, B.M., & Samuels, H.H. (1990). Interactions among a subfamily of nuclear hormone receptors: the regulatory zipper model. *Mol. Endocrinol.* 4, 1293–1301.
- Hodin, R.A., Lazar, M.A., Wintman, B.I., Darling D.D., Koenig, R.J., Larsen, P.R., Moore, D.D., & Chin, W.W. (1989). Identification of a thyroid hormone receptor that is pituitary specific. *Science* 244, 76–79.
- Kurokawa, R., Yu, V.C., Naar, A., Kyakumoto, S., Han, Z., Silverman, S., Rosenfeld, M.G., & Glass, C.K. (1993). Differential orientations of the DNA-binding domain and carboxyterminal dimerization interface regulate binding site selection by nuclear receptor heterodimers. *Genes & Dev.* 7, 1423–1435.
- Lazar, M.A., Hodin, R.A., & Chin, W.W. (1989). Human carboxyl-terminal variant of α -type c-erbA inhibits trans-activation by thyroid hormone receptors without binding thyroid hormone. *Proc. Natl. Acad. Sci. USA* 86, 7771–7774.
- Lazar, M.A. (1993). Thyroid hormone receptors: multiple forms, multiple possibilities. *Endocr. Rev.* 14, 184–193.
- Leid, M., Kastner, P., Lyons, R., Nakshatri, H., Saunders, M., Zacharewski, T., Chen, J., Staub, A., Garnier, J.-M., Mader, S., & Chambon, P. (1992). Purification, cloning, and RXR identity of the HeLa cell factor with which RAR or TR heterodimerizes to bind target sequences efficiently. *Cell* 68, 377–395.
- Magnusson, R.P., Gastantas, J., Seto, P., Taurog, A., & Rapoport, B. (1986). Molecular cloning of the porcine thyroid peroxidase. *FEBS Lett.* 208, 391–394.
- Naar, A.M., Boutin, J.-M., Lipkin, S.M., Yu, V.C., Holloway, J.M., Glass, C.K., & Rosenfeld, M.G. (1991). The orientation and spacing of core DNA binding motif dictate selective transcriptional responses by three nuclear receptors. *Cell* 65, 1267–1279.
- O'Donnell, A.L., & Koenig, R.J. (1990). Mutational analysis identifies a new functional domain of the thyroid hormone receptor. *Mol. Endocrinol.* 4, 715–720.
- Oppenheimer, J.H., Schwartz, H.L., Mariash, C.N., Kinlaw, W.B., Wong, N.C.W., & Freake, H.C. (1987). Advances in our understanding of thyroid hormone action at the cellular level. *Endocr. Rev.* 8, 288–308.

- Perlmann, T., Rangarajan, P.N., Umesono, K., & Evans, R.M. (1993). Determinants for selective RAR/TR recognition of direct repeat HREs. *Genes & Dev.* 7, 1411–1422.
- Samuels, H.H. (1983). Identification and characterization of thyroid hormone receptors and action using cell culture techniques. In: *Molecular Basis of Thyroid Hormone Action* (Oppenheimer, J.H., & Samuels, H.H., Eds.), pp. 35–65. Academic Press, New York.
- Sap, J., Munoz, A., Damm, K., Goldberg, Y., Ghysdael, J., Lentz, A., Beug, H., & Vennstrom, B. (1986). *Nature* 324, 635–640.
- Umesono, K., Murakami, K.K., Thompson, C.C., & Evans, R.M. (1991). Direct repeats as selective response elements for the thyroid hormone, retinoic acid, and vitamin D3 receptors. *Cell* 65, 1255–1266.
- Usala, S.J., & Weintraub, B.D. (1991). Thyroid hormone resistance syndromes. *TEM* 2, 140–144.
- Utiger, R.D. (1988). In: *Endocrinology and Metabolism* (Felig, P., Baxter, J.D., Broadus, A.E., & Frohman, L.A., Eds.), pp. 389–472. McGraw-Hill, New York.
- Vassart, G., Brocas, H., Cabrer, B. et al. (1985). Structure and expression of the thyroglobulin gene. In: *Thyroglobulin-The Prothyroid Hormone* (Eggo, M.C., & Burrow, G.N., Eds.), Vol 2, pp. 55–68. Raven, New York.
- Weiss, R.E., & Refetoff, S. (1992). Thyroid hormone resistance. *Ann. Rev. Med.* 43, 363–375.
- Weinberger, C., Thompson, C.C., Ong, E.S., Lebo, R., Gruol, D.J., & Evans, R.M. (1986). The c-erbA gene encodes a thyroid hormone receptor. *Nature* 324, 641–646.
- Werner, S.C. (1991). *The Thyroid* (Braverman, L.E., & Utiger, R.D., Eds.). B. Lippincott, Philadelphia.
- Yen, P.M., Darling, D.S., Carter, R.L., Forgione, M., Umeda, P.K., & Chin, W.W. (1992). Triiodothyronine decreases binding to DNA by T3 receptor homodimers but not receptor-auxiliary protein heterodimers. *J. Biol. Chem.* 267, 3565–3568.
- Yu, V.C., Delsert, C., Anderson, B., Holloway, J.M., Devary, O.V., Naar, A.M., Kim, S.Y., Boutin, J.-M., Glass, C.K., & Rosenfeld, M.G. (1991). RXR β : a coregulator that enhances binding of retinoic acid, thyroid hormone, and vitamin D receptors to their cognate response elements. *Cell* 67, 1251–1266.

This Page Intentionally Left Blank