

The Handbook of Environmental Chemistry 47  
Series Editors: Damià Barceló · Andrey G. Kostianoy

Tamim Younos  
Tammy E. Parece *Editors*

# Sustainable Water Management in Urban Environments

 Springer

# **The Handbook of Environmental Chemistry**

**Founded by Otto Hutzinger**

**Editors-in-Chief: Damià Barceló • Andrey G. Kostianoy**

**Volume 47**

## **Advisory Board:**

**Jacob de Boer, Philippe Garrigues, Ji-Dong Gu,  
Kevin C. Jones, Thomas P. Knepper, Alice Newton,  
Donald L. Sparks**

More information about this series at <http://www.springer.com/series/698>

# Sustainable Water Management in Urban Environments

Volume Editors: Tamim Younos · Tammy E. Parece

With contributions by

M.M. Abou Rayan · M. Accorsi · J. Battiata · D. Bork ·  
T.A. Buchholz · J.B. Campbell · J.-m. Che · Y.-s. Chen ·  
D. Crawford · B. Djebedjian · M. Feilberg · G. Gianquinto ·  
R.-r. Hao · D. Hirschman · M. Lumpkin · P. Luz ·  
D.A. Madary · F.S. Makoni · O. Mark · P.A. Mbatia ·  
A. McAvoy · F. Orsini · K. O'Neill · T.E. Parece · T. Shen ·  
S. Sojka · O.M.M. Thekisoe · I.L. Tsirogiannis · T. Younos ·  
Q. Zhang · L.-t. Zhu



Springer

*Editors*

Tamim Younos  
Green Water-Infrastructure Academy  
Washington, DC  
USA

Tammy E. Parece  
Department of Geography  
Virginia Polytechnic Institute and  
State University  
Blacksburg, VA  
USA

ISSN 1867-979X                      ISSN 1616-864X (electronic)  
The Handbook of Environmental Chemistry  
ISBN 978-3-319-29335-6              ISBN 978-3-319-29337-0 (eBook)  
DOI 10.1007/978-3-319-29337-0

Library of Congress Control Number: 2016938911

© Springer International Publishing Switzerland 2016

This work is subject to copyright. All rights are reserved by the Publisher, whether the whole or part of the material is concerned, specifically the rights of translation, reprinting, reuse of illustrations, recitation, broadcasting, reproduction on microfilms or in any other physical way, and transmission or information storage and retrieval, electronic adaptation, computer software, or by similar or dissimilar methodology now known or hereafter developed.

The use of general descriptive names, registered names, trademarks, service marks, etc. in this publication does not imply, even in the absence of a specific statement, that such names are exempt from the relevant protective laws and regulations and therefore free for general use.

The publisher, the authors and the editors are safe to assume that the advice and information in this book are believed to be true and accurate at the date of publication. Neither the publisher nor the authors or the editors give a warranty, express or implied, with respect to the material contained herein or for any errors or omissions that may have been made.

Printed on acid-free paper

This Springer imprint is published by Springer Nature  
The registered company is Springer International Publishing AG Switzerland

---

## Editors-in-Chief

Prof. Dr. Damià Barceló

Department of Environmental Chemistry  
IDAEA-CSIC

C/Jordi Girona 18–26

08034 Barcelona, Spain

and

Catalan Institute for Water Research (ICRA)

H20 Building

Scientific and Technological Park of the

University of Girona

Emili Grahit, 101

17003 Girona, Spain

*dbcqam@cid.csic.es*

Prof. Dr. Andrey G. Kostianoy

P.P. Shirshov Institute of Oceanology

Russian Academy of Sciences

36, Nakhimovsky Pr.

117997 Moscow, Russia

*kostianoy@gmail.com*

## Advisory Board

Prof. Dr. Jacob de Boer

IVM, Vrije Universiteit Amsterdam, The Netherlands

Prof. Dr. Philippe Garrigues

University of Bordeaux, France

Prof. Dr. Ji-Dong Gu

The University of Hong Kong, China

Prof. Dr. Kevin C. Jones

University of Lancaster, United Kingdom

Prof. Dr. Thomas P. Knepper

University of Applied Science, Fresenius, Idstein, Germany

Prof. Dr. Alice Newton

University of Algarve, Faro, Portugal

Prof. Dr. Donald L. Sparks

Plant and Soil Sciences, University of Delaware, USA



# The Handbook of Environmental Chemistry

## Also Available Electronically

*The Handbook of Environmental Chemistry* is included in Springer's eBook package *Earth and Environmental Science*. If a library does not opt for the whole package, the book series may be bought on a subscription basis.

For all customers who have a standing order to the print version of *The Handbook of Environmental Chemistry*, we offer free access to the electronic volumes of the Series published in the current year via SpringerLink. If you do not have access, you can still view the table of contents of each volume and the abstract of each article on SpringerLink ([www.springerlink.com/content/110354/](http://www.springerlink.com/content/110354/)).

You will find information about the

- Editorial Board
- Aims and Scope
- Instructions for Authors
- Sample Contribution

at [springer.com](http://springer.com) ([www.springer.com/series/698](http://www.springer.com/series/698)).

All figures submitted in color are published in full color in the electronic version on SpringerLink.

## Aims and Scope

Since 1980, *The Handbook of Environmental Chemistry* has provided sound and solid knowledge about environmental topics from a chemical perspective. Presenting a wide spectrum of viewpoints and approaches, the series now covers topics such as local and global changes of natural environment and climate; anthropogenic impact on the environment; water, air and soil pollution; remediation and waste characterization; environmental contaminants; biogeochemistry; geocology; chemical reactions and processes; chemical and biological transformations as well as physical transport of chemicals in the environment; or environmental modeling. A particular focus of the series lies on methodological advances in environmental analytical chemistry.





## Series Preface

With remarkable vision, Prof. Otto Hutzinger initiated *The Handbook of Environmental Chemistry* in 1980 and became the founding Editor-in-Chief. At that time, environmental chemistry was an emerging field, aiming at a complete description of the Earth's environment, encompassing the physical, chemical, biological, and geological transformations of chemical substances occurring on a local as well as a global scale. Environmental chemistry was intended to provide an account of the impact of man's activities on the natural environment by describing observed changes.

While a considerable amount of knowledge has been accumulated over the last three decades, as reflected in the more than 70 volumes of *The Handbook of Environmental Chemistry*, there are still many scientific and policy challenges ahead due to the complexity and interdisciplinary nature of the field. The series will therefore continue to provide compilations of current knowledge. Contributions are written by leading experts with practical experience in their fields. *The Handbook of Environmental Chemistry* grows with the increases in our scientific understanding, and provides a valuable source not only for scientists but also for environmental managers and decision-makers. Today, the series covers a broad range of environmental topics from a chemical perspective, including methodological advances in environmental analytical chemistry.

In recent years, there has been a growing tendency to include subject matter of societal relevance in the broad view of environmental chemistry. Topics include life cycle analysis, environmental management, sustainable development, and socio-economic, legal and even political problems, among others. While these topics are of great importance for the development and acceptance of *The Handbook of Environmental Chemistry*, the publisher and Editors-in-Chief have decided to keep the handbook essentially a source of information on "hard sciences" with a particular emphasis on chemistry, but also covering biology, geology, hydrology and engineering as applied to environmental sciences.

The volumes of the series are written at an advanced level, addressing the needs of both researchers and graduate students, as well as of people outside the field of "pure" chemistry, including those in industry, business, government, research

establishments, and public interest groups. It would be very satisfying to see these volumes used as a basis for graduate courses in environmental chemistry. With its high standards of scientific quality and clarity, *The Handbook of Environmental Chemistry* provides a solid basis from which scientists can share their knowledge on the different aspects of environmental problems, presenting a wide spectrum of viewpoints and approaches.

*The Handbook of Environmental Chemistry* is available both in print and online via [www.springerlink.com/content/110354/](http://www.springerlink.com/content/110354/). Articles are published online as soon as they have been approved for publication. Authors, Volume Editors and Editors-in-Chief are rewarded by the broad acceptance of *The Handbook of Environmental Chemistry* by the scientific community, from whom suggestions for new topics to the Editors-in-Chief are always very welcome.

Damià Barceló  
Andrey G. Kostianoy  
Editors-in-Chief

# Volume Preface

In the twenty-first century, global urban environments are facing serious challenges including (1) convergence of population in urban areas – at present, 80.7 % of the total U.S. population and 54 % of the total global population reside in urban areas and show an increasing trend; (2) competition for water demand for other essentials such as food production; (3) cost-prohibitive water-infrastructure development, particularly in developing countries; (4) energy dependence of urban water-infrastructure; and (5) significant threats posed by climate change. Furthermore, in modern cities water is also valued for ecosystem protection, recreation, and aesthetics. Conventional water-infrastructure (potable water, wastewater disposal, and stormwater runoff) in urban areas are planned, designed, and managed on separate tracks. These practices have proven to be highly inefficient resulting in water and energy losses, groundwater decline, and surface water quality degradation. Therefore, a significant need exists toward a paradigm shift for holistic and sustainable water management in urban areas. Research and development in new approaches and technologies provide tremendous and exciting opportunities for this endeavor. This volume presents a discussion of concepts, methodologies, and case studies of innovative and evolving technologies in the arena of urban water management. Themes discussed include (1) challenges in urban water resiliency; (2) water and energy nexus; (3) integrated urban water management; (4) and water reuse options (black water, gray water, rainwater).

This volume contains ten chapters. The chapter “[Integrated Urban Water Management: Improve Efficient Water Management and Climate Change Resilience in Cities](#)” discusses the concept for holistic planning to improve water management by linking different elements such as spatial planning, stormwater management, and urban environment. The chapter “[Carbon Footprint of Water Consumption in Urban Environments: Mitigation Strategies](#)” provides an overview of the nexus between water and energy in urban areas and discusses specific mitigation strategies for reducing the carbon footprint of water consumption. The chapter “[Reclaimed Water Use and Energy Consumption: Case Study in Hotel Industry, Beijing](#)” discusses the water balance and energy consumption

relationship for reclaimed water systems, constructing a safety index for the hotel industry in Beijing. The chapter “[Urban Stormwater Management: Evolution of Process and Technology](#)” discusses the history of urban stormwater management and provides an outline of the stormwater management regulatory goals and the corresponding urban stormwater management design strategies. The chapter “[Stream Restoration in Urban Environments: Concept, Design Principles and Case Studies of Stream Daylighting](#)” explores the viability of urban stream daylighting as a stream-restoration and green infrastructure technology and methods of site selection, stream analysis, and natural stream channel design along with construction considerations in urban environments. The chapter “[Sustainable Water Management in Green Roofs](#)” discusses water management strategies with regard to the sustainable practice of irrigation using alternative water sources on green roofs. The chapter “[Modern Rainwater Harvesting Systems: Design, Case Studies, Impacts](#)” focuses on rainwater harvesting systems design and discusses environmental impacts, economic and life cycle assessment of rainwater harvesting systems in urban environments. The chapter “[Irrigating Urban Agriculture with Harvested Rainwater: Case Study in Roanoke, Virginia, USA](#)” discusses a case study where using geospatial analysis, they calculate the potential for rooftop rainwater capture for urban food production and the impact on stormwater runoff reduction. The chapter “[Urban Wastewater for Sustainable Urban Agriculture and Water Management in Developing Countries](#)” discusses urban agriculture as one way to bolster urban food supplies whilst enhancing safe disposal of wastewater and provide management strategies and socioeconomic benefits based on field experiments. The chapter “[Urban Water Management Challenges in Developing Countries: The Middle East and North Africa \(MENA\)](#)” discusses challenges facing urban water management in developing countries, the framework for Integrated Urban Water Management in the MENA region, including the salient socioeconomic and environmental stresses, and approaches for international cooperation.

In the chapter “[Integrated Urban Water Management: Improve Efficient Water Management and Climate Change Resilience in Cities](#),” Feilberg and Mark state that urban water managers face challenges due to flooding and extreme weather events, which will increase in severity because of climate change particularly in cities located in coastal and delta areas. Authors introduce the concept of Integrated Urban Water Management (IUWM) by linking different elements such as spatial planning, stormwater management to provide a more holistic input to urban water management planning. They discuss barriers and a number of solutions in order to overcome the barriers to IUWM approaches.

In the chapter “[Carbon Footprint of Water Consumption in Urban Environments: Mitigation Strategies](#),” Younos, O’Neill, and McAvoy state that energy consumption attributed to water services in urban areas constitutes a significant portion of total energy resources around the world. Authors provide an overview of the nexus between water and energy in urban areas, estimates of energy consumption in urban water infrastructure, the associated carbon footprint of water consumption, and specific mitigation strategies for reducing the carbon footprint of water consumption. Authors discuss the potential for integrating renewable energy resources into

urban water infrastructure in order to reduce dependence on fossil fuel-based energy.

In the chapter “[Reclaimed Water Use and Energy Consumption: Case Study in Hotel Industry, Beijing](#),” Chen, Zhu, Che, and others discuss the importance of analyzing the relationship between water balance and energy consumption for buildings that use reclaimed water systems. Authors analyze the energy consumption intensity, the corresponding quantitative relationship with water quantity, and the major points of energy consumption and provide a reference model for research and analysis of the water balance energy consumption relationship for reclaimed water systems. Authors propose a safety index for the hotel industry in Beijing and make recommendations for improving in-building reclaimed water use system efficiencies.

In the chapter “[Urban Stormwater Management: Evolution of Process and Technology](#),” Hirschman and Battiata discuss the history of urban stormwater management. They state that while in the beginning stormwater management was primarily concerned with abating downstream flooding and was the sole domain of engineers, as the regulatory climate changed over time, modern stormwater management design must reach beyond sole reliance on engineering and incorporate elements of soil science, horticulture, landscape architecture, and, importantly, site planning. Authors outline stormwater management regulatory goals and corresponding design strategies and illustrate examples of how these approaches are changing the structural and nonstructural design of the urban landscape.

In the chapter “[Stream Restoration in Urban Environments: Concept, Design Principles and Case Studies of Stream Daylighting](#),” Buchholz, Madary, Bork, and Younos discuss the history of urban stream development, mainly underground pipes, and explore the viability of urban stream daylighting as a stream-restoration and green infrastructure technology. Authors describe methods of site selection, stream analysis, and natural stream channel design along with construction considerations in urban environments and review four case studies in the United States. They conclude that although urban stream daylighting projects are on the rise, costs and technical complexity are major impediments for stream daylighting in urban areas.

In the chapter “[Sustainable Water Management in Green Roofs](#),” Orsini, Accorsi, Luz, and others discuss the contribution of green roofs in management of the urban water cycle. Authors present proper water management strategies, specifically with regard to the sustainable practice of irrigation and the definition of water quality standards. They discuss using alternative water sources, such as rainwater harvesting and gray water regeneration, and describe environmental, ecological, and financial benefits associated with rooftop greening including life cycle cost assessment. Authors analyze ecosystem services provision, specifically in relation to the role played by water in improving urban microclimate, air quality, and promoting resilience to climate change.

In the chapter “[Modern Rainwater Harvesting Systems: Design, Case Studies, Impacts](#),” Sojka, Younos, and Crawford discuss the increased popularity of rainwater harvesting due to increasing demands on strained water supplies and

infrastructure and increasing awareness of the benefits of green water-infrastructure. Authors describe active rainwater harvesting systems in urban areas, in which captured rainwater can be a major source of water supplying nonpotable end uses such as irrigation, toilet flushing, and cooling towers, and occasionally for potable water. Authors describe environmental impacts, economic and life cycle assessment of rainwater harvesting systems, and make recommendations for future research needs.

In the chapter “[Irrigating Urban Agriculture with Harvested Rainwater: Case Study in Roanoke, Virginia, USA](#),” Parece, Lumpkin, and Campbell discuss the importance of urban greenspaces in providing environmental benefits and state that urban agriculture forms a greenspace that can provide these environmental benefits in addition to contributing to food security for local populations. Authors discuss a case study based upon using aerial imagery to identify areas of existing urban agriculture in the city and potential new urban agricultural sites, and from aerial images and city geospatial data identify and calculate roof areas that provide a source of captured rainwater. Authors discuss reductions that could occur in stormwater runoff and greenhouse gas emissions if harvested rainwater were used instead of municipal water supplies, and present future research areas for urban agriculture and rainwater harvesting.

In the chapter “[Urban Wastewater for Sustainable Urban Agriculture and Water Management in Developing Countries](#),” Makoni, Thekisoe, and Mbatii provide an overview of water scarcity in developing countries and its impact on agricultural food production. Authors address issues of wastewater generated through domestic/commercial use and its beneficial uses for urban agriculture as an alternative source of irrigation water, and highlight pertinent issues of urban agriculture as one way to bolster urban food supplies whilst enhancing safe disposal of wastewater for environmental and public health consideration. In addition, authors discuss management strategies based on field experiments for sustainable utilization of treated domestic wastewater for irrigated agriculture, and provide evidence of socioeconomic benefits of wastewater use in improving the livelihoods for the urban poor.

In the chapter “[Urban Water Management Challenges in Developing Countries: The Middle East and North Africa \(MENA\)](#),” Abou Rayan and Djebedjian discuss accelerated growing population and migration to urban areas in developing countries and the vital need for the establishment of protected source water and modern, well-maintained drinking water treatment plants to disseminate potable water to residents. Authors discuss water consumption, challenges facing urban water management in developing countries including climate change, and the framework for Integrated Urban Water Management in the MENA region. Authors conclude that approaches for advanced international and intersectoral cooperation and for identifying and strengthening intellectual and technical resources, tools, lessons, and best practices should be shared, applied, or adapted across the region. Authors make recommendations for improved management of water resources in MENA countries.

Chapters presented in this volume primarily focus on practical aspects of sustainable water management in urban areas. We hope this volume serves as a

textbook and reference material and cross-disciplinary source for graduate students and researchers involved in holistic approaches for water management. Equally, we hope this volume serves as a valuable guide to experts in governmental agencies who are concerned with water availability and water quality issues and engineers and other professionals involved with the design of land and water management systems in urban environments.

Washington, DC  
USA  
Blacksburg, VA  
USA

Tamim Younos  
Tammy E. Parece





# Contents

<b>Integrated Urban Water Management: Improve Efficient Water Management and Climate Change Resilience in Cities . . . . .</b>	<b>1</b>
Miriam Feilberg and Ole Mark	
<b>Carbon Footprint of Water Consumption in Urban Environments: Mitigation Strategies . . . . .</b>	<b>33</b>
Tamim Younos, Katherine O’Neill, and Ashley McAvoy	
<b>Reclaimed Water Use and Energy Consumption: Case Study in Hotel Industry, Beijing . . . . .</b>	<b>57</b>
Yuan-sheng Chen, Long-teng Zhu, Jian-ming Che, Rui-rui Hao, Tian Shen, and Qian Zhang	
<b>Urban Stormwater Management: Evolution of Process and Technology . . . . .</b>	<b>83</b>
David Hirschman and Joseph Battiata	
<b>Stream Restoration in Urban Environments: Concept, Design Principles, and Case Studies of Stream Daylighting . . . . .</b>	<b>121</b>
Tracy A. Buchholz, David A. Madary, Dean Bork, and Tamim Younos	
<b>Sustainable Water Management in Green Roofs . . . . .</b>	<b>167</b>
Francesco Orsini, Mattia Accorsi, Paulo Luz, Ioannis L. Tsirogiannis, and Giorgio Gianquinto	
<b>Modern Urban Rainwater Harvesting Systems: Design, Case Studies, and Impacts . . . . .</b>	<b>209</b>
Sarah Sojka, Tamim Younos, and David Crawford	
<b>Irrigating Urban Agriculture with Harvested Rainwater: Case Study in Roanoke, Virginia, USA . . . . .</b>	<b>235</b>
Tammy E. Parece, Malayshia Lumpkin, and James B. Campbell	

**Urban Wastewater for Sustainable Urban Agriculture and Water Management in Developing Countries** . . . . . 265  
Fungai S. Makoni, Oriel M.M. Thekisoe, and Peter A. Mbatl

**Urban Water Management Challenges in Developing Countries: The Middle East and North Africa (MENA)** . . . . . 295  
Magdy M. Abou Rayan and Berge Djebedjian

**Index** . . . . . 327

# Integrated Urban Water Management: Improve Efficient Water Management and Climate Change Resilience in Cities

Miriam Feilberg and Ole Mark

## Contents

1	Introduction .....	2
2	Integrated Urban Water Management: International Definitions .....	3
3	Barriers to Integrated Urban Water Management .....	6
3.1	Brief Introduction to Water Management in Denmark .....	7
4	Cases: Cities Facing Different Challenges .....	10
4.1	Climate Change Adaptation in Odense .....	10
4.2	Flooding of Usserød Stream, Kokkedal, near Copenhagen .....	12
4.3	Flooding in Stenløse City: Egedal Municipality .....	13
4.4	Present Barriers to More Integrated Solutions .....	14
4.5	Funding of Climate Change Adaptation and Remaining Barriers .....	17
4.6	Proposed Solutions .....	17
5	Suggestions to Move Towards Integrated Solutions .....	18
5.1	Improved Cooperation Between Municipality and Utility .....	18
5.2	Cooperation Internally Within the Municipality .....	19
5.3	Clear Rules on Funding Stormwater Management and Climate Change Adaptation .....	19
5.4	Insurance Systems to Improve Climate Change Adaptation .....	20
5.5	Improved Coherence Between Policy Areas .....	20
5.6	Improved Cooperation Across Catchments .....	20
5.7	Improved Stakeholder Integration .....	21
5.8	Climate Change Experiences and Evaluation of Projects .....	22
6	Cases: What Can Be Achieved? .....	22
6.1	Integrated Management Solutions: Aarhus, Denmark .....	22
6.2	Urban Flooding in a Low-Lying Area: Greve Municipality, Denmark .....	25
6.3	Securing Safe Bathing Water: Copenhagen, Denmark .....	26
6.4	Control of Urban Waterborne Infectious Disease: Dhaka, Bangladesh .....	27
7	Conclusion .....	30
	References .....	31

---

M. Feilberg • O. Mark (✉)  
DHI, Hørsholm, Denmark  
e-mail: [Ole.Mark@dhigroup.com](mailto:Ole.Mark@dhigroup.com)

**Abstract** Today, more than half of the world's population is living in cities that are often centres of production, prosperity and development, but when it comes to handling water in urban areas, a number of challenges exist related to providing safe and efficient solutions to urban water issues. Challenges urban water managers face include flooding and extreme weather events, which will increase in severity because of climate change. Cities located in coastal and delta areas already face the risk of increased flooding and other extreme events, which climate change will further aggravate. In Denmark, the Ministry of the Environment envisages that a sea level rise of 0.7 m on average will lead to increased flooding similar to a 400-year event taking place every 1–2 years; thus, cities must do their utmost to improve climate change resilience. Introducing integrated urban water management (IUWM) as a concept for planning to improve water management by linking different elements such as spatial planning, stormwater management and urban environment provides a more holistic input to planning. In this chapter, we examine definitions of IUWM and global experiences. Furthermore, we look at experienced barriers to moving towards more integrated water management and a number of solutions in order to overcome the barriers to integrated approaches. Finally, we describe how solutions based on innovative and integrated approaches are efficient and contribute to improved water management even though not every single element of urban water management can be a part of integrated solutions.

**Keywords** Integrated urban water management • Real-time control and monitoring • Stakeholder integration • Urban climate change adaptation • Urban flooding

## 1 Introduction

Climate change impact cities significantly and will continue to do so in the future. These impacts have serious potential consequences for human health, livelihoods, and assets, especially for the urban poor, informal settlements and other vulnerable groups. Climate change impact ranges from an increase in extreme weather events and flooding to higher temperatures and public health concerns. Cities in low-elevation coastal zones, for instance, face the combined threat of sea level rise and storm surges. Specific impacts on each city will depend on the actual changes in climate experienced (e.g. higher temperatures or increased rainfall), which will vary from place to place, but a number of general challenges are to be expected for water managers when dealing with climate change, such as:

- Predict what will happen in the city of the future, and establish scientifically sound predictions of climate change.

- Determine the expected service levels in the future, i.e. how often to allow flooding on roads and private property in the cities.
- Identify areas having the highest risk of flooding and target these areas for interventions.
- Identify areas where flooding will be most costly and protect assets of particularly high value.
- Develop climate change adaptation plans.
- Develop emergency plans for unescapable extreme events.

To meet these challenges, more and more cities, organisations, and decision makers are moving towards integrated solutions – applying a holistic approach to urban water challenges. A holistic approach means consideration of all aspects – stormwater, groundwater, surface water, bathing waters, recreational areas and linkages to marine waters for urban water management – to work with stakeholders and consider the health and livelihoods of citizens as elements in water management. We provide further definitions later in this chapter.

The need to focus on climate change and to move towards holistic approaches is recognised. An example is the outcome from the Water in Cities at the 7th World Water Forum in Korea in April 2015 – the Implementation Roadmap (forum outcome) which states:

Climate change awareness has brought Cities to face the reality of water related disasters and chronic stress. Climate change adaptation has come up on Cities agenda with water being a major focus point. Cities are now working on reducing their water related risk to move towards the risk-resilient city. The *realization* that the urban water cycle needs to reconnect to the natural water cycle is central to this transition. New urban areas and infills will embrace principles such as increasing the buffer capacity to cope with natural rainfall, shaping the urban landscape to allow for non-destructive flooding, reconnecting to the upstream watersheds to restore healthy hydraulic regimes of rivers. [1]

In this chapter, we detail actual impacts of climate change in cities and the challenges that cities are facing in order to overcome these impacts. First, we examine the different definitions of integrated urban water management (IUWM) and what IUWM covers.

## 2 Integrated Urban Water Management: International Definitions

In a study developed by DHI and DTU (Technical University of Denmark), as an element of a Danish ‘Water in Cities’ [2] innovation project, we examined a number of international cases, where cities have been working towards more integrated solutions for the management of water-related extreme events and climate change adaptation. These studies cover cities in Europe – Paris, Amsterdam, Rotterdam, London, Hamburg, as well as the UK in general – the USA, Australia and international organisations such as Global Water Partnership and World Meteorological

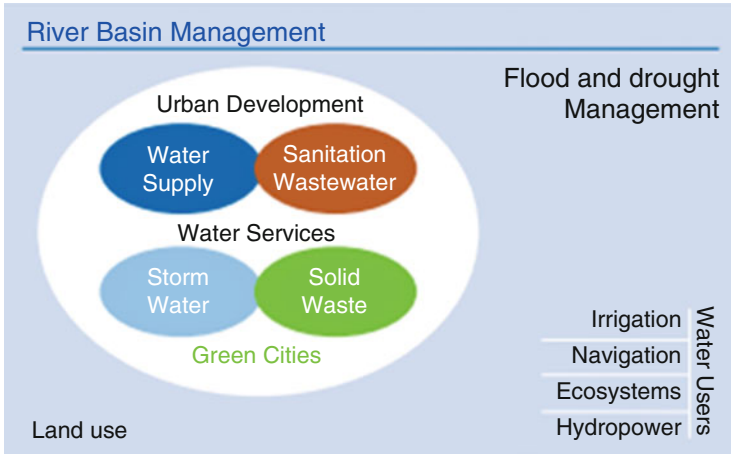
Organisation. The experiences from the cities vary to some extent, and recommendations include different aspects such as (1) making sure a coherent information management system exists; (2) identifying a clear distribution of responsibilities for citizens, authorities and other stakeholders; (3) including stakeholders across administrative boundaries; and (4) joint planning of urban areas and climate change adaptation.

International cases point towards a number of different technical solutions (such as stormwater roads, green roofs, recreational solutions) and many different administrative systems and rules, but encompass many common features of IUWM [3], such as:

- Water is managed as one combined resource in its hydrological cycle, including both quantity and quality.
- Urban water management is coordinated with management of the whole water resource in the basin area.
- Improved conditions are created for better coordination of physical planning and water planning in cities.
- Natural elements within the cities (lakes, rivers and streams) are integrated into the combined management of urban water (abstraction, storing, reuse, discharge, etc.) together with technical infrastructure.
- Management is carried out at the lowest appropriate administrative level, as close to the actual needs as possible.
- Some overall principles seem to be commonly accepted – ‘water has an economic value and must be managed accordingly’, ‘the polluter pays principle’, and ‘solutions must not only look into economic but also environmental and social conditions’.
- One entity – whether a municipality, a water company or a local administrative entity – has the overall coordinating responsibility.
- Facilitation of stakeholder inclusion and establishment of broad networks with many public and private partners.

Looking at the general, internationally accepted principles of integrated water resources management – the IWRM principles – many similarities occur such as management at the lowest appropriate level, the participatory approach, seeing water as a resource and securing distribution between economy and environment for all users. The Global Water Partnership promotes these principles because urban water management is a growing challenge all over the world.

Another example is a study from the World Bank, where a group of urban water experts have carried out a review of different projects on integrated urban water leading towards a definition of what is included in the IUWM approach as well as a number of recommendations for the way forward. They call for a paradigm shift from a traditional focus on technological solutions to more integrated solutions focusing on the synergies between general urban planning and design and water management, where urban water is viewed as an asset with a value in itself and closely interlinked with water in the local basin:



**Fig. 1** Links between IUWM (Source: Authors)

Urban development is achieved by bringing together the components that affect urban water management: storm water, sanitation, water supply, and solid waste (Fig. 1). The links between the urban system and the watershed are combined with social participation and management integration to produce optimal social, economic, and environmental outcomes. Managing urban water across different institutions and organizations while allowing all players and end-users to be part of the process ensures the sustainability of the process and its outcomes. [4]

Other organisations such as Organisations for Economic Co-operation and Development (OECD) [5] and International Water Association (IWA) [6] are also actively engaged in promoting better solutions for urban water management and focus on urban water governance. At the 7th World Water Forum in Korea in April 2015, one topic was *Water in Cities* with input from major organisations and regions all over the world. From Europe, DHI facilitated a discussion and presented case studies on innovative and integrated urban water management from all over Europe. The discussion focused on general European challenges and resulted in a set of recommendations for improved water management. In Europe, the Water Framework Directive regulates, largely, the overall policy framework complemented by groundwater, floods, urban wastewater treatment, drinking water and bathing water directives. However, outstanding challenges in Europe [7] include:

- Climate change and urban planning need to go from response to preparedness and secure better links with other policy areas, such as the floods directive.
- Connect local initiatives with city policies thru holistic approaches and by bridging the gap between technicians, politicians and civil societies. Although a generally accepted fact, only a few success stories exist, and consequently, methodologies to improve this element require development.



- Wastewater treatment is still a challenge in many places in Europe. Participants in the sessions explained the need to stop seeing wastewater as waste, rather as a resource utilised locally or globally. Different conditions exist in newly constructed urban areas; in some places, relying completely on local treatment is feasible. Successful implementation has occurred in cities such as Hamburg or in an old city like Paris.

Recommendations from the discussions at World Water Forum echo similar international discussions and point towards the following needs:

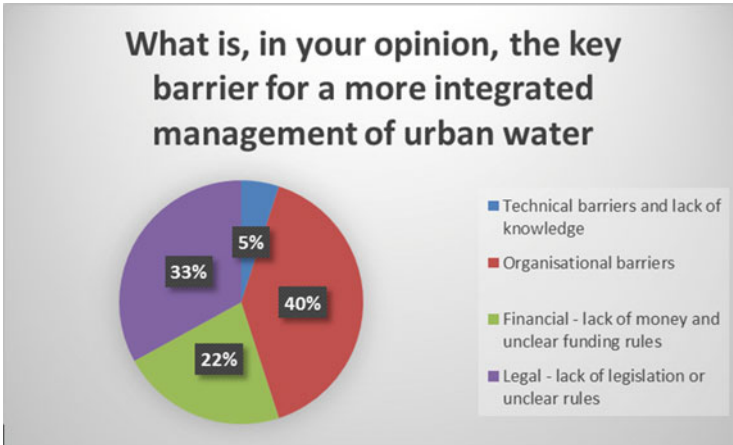
- Focus on the true cost of water as a key driver for water efficiency.
- Include other elements such as political commitment, regulatory frameworks that increase urban water efficiency, smart and innovative technologies and household appliances.
- Improve global knowledge sharing related to the European solutions, the European policy framework and the European structure for data collection, monitoring and management (European Union Member States (EU MS), European Commission (EC), and European Economic Area (EEA)).
- Promote increased sharing of experiences and work with existing networks and projects, city blueprints, European Innovation Partnerships (EIP) action groups and European Technology Platform for Water (WssTP) working groups, Delta Alliance, C40 and other similar organisation.

In addition, it is important to establish business cases for integrated urban water management to make utilities and industries part of the solution. For example, urban industrial symbiosis projects for sharing and joint utilisation of resources between different industries and utilities make it more relevant for industries to participate in these activities.

### **3 Barriers to Integrated Urban Water Management**

The question – *what are the barriers to more integrated urban water management with regard to climate change and extreme rain events?* – was posed to DHI in the Danish ‘Water in Cities’ innovation project.

To answer this question, we developed a case-based approach – we analysed 15 different cases, where utilities and municipalities had experienced specific challenges related to prevention and managing of extreme rain events. The cases represented small and large cities in Denmark and the challenges were seen from the municipalities’ as well as the utilities’ points of view. In Denmark, municipalities own most large utilities, but the utility functions as independent, private companies with their own boards and staff. They are also financially independent and able to set their prices with some flexibility within a price cap established by the economic regulator – a national entity within the Ministry of Finance.



**Fig. 2** Danish perception of barriers to implementation of IUWM (*Source: Authors*)

The challenges faced represent various issues, for example, lack of clarity with interventions on private property and difficulties related to cooperation between different stakeholders, between utility and municipality and between different entities within the municipality. Issues related to lack of funds also exist, but the main barriers are a lack of clarity on how to use the funds and how to finance investments and running costs. Furthermore, different rules apply for interventions defined as climate change adaptation or as usual stormwater management. Furthermore, rules change, as do ongoing reforms for funding of water management.

In this chapter, we will not present all cases but give some examples and present the general picture and the overall conclusions about the challenges and barriers that urban water managers are facing.

The technical elements and solutions were not the core focus of this project, and following the initial discussions in the project group, these are not viewed as the key challenge by water managers in urban areas. In November 2014 at a national ‘Water in Cities’ conference in Denmark, participants from all over the water sector in Denmark confirmed that the key challenges in urban water are organisational, financial and legislative barriers. Only 5 % stated that the key barrier was technical; see Fig. 2.

### ***3.1 Brief Introduction to Water Management in Denmark***

In order to understand the challenges and the suggested solutions, here, we, briefly, introduce water management in Denmark.

For Denmark as an EU member state, the Water Framework Directive and other EU directives are the basis for water management. The Danish water ministry is the Ministry of the Environment, and the implementing agency, the Nature Agency, is

the national body responsible for the development of national water policies and strategies implemented through the EU-defined water plans. Denmark is organised in 23 water or river basins, and for each of them, the Nature Agency develops a water plan with input from the municipalities. In addition, the Nature Agency is responsible for policymaking and regulations with regard to wastewater, climate change adaptation, urban water and industrial water management.

As Fig. 3 demonstrates, compared to other countries, water management in Denmark has a relatively simple structure, as basically only one national agency is responsible for all elements except establishing prices, whereas other countries may have up to 10 or 13 entities. This simple structure exists for all elements related to water, also for urban water. Municipalities and their environment units are managing water and environment controls, as well as abstraction and discharge permits.

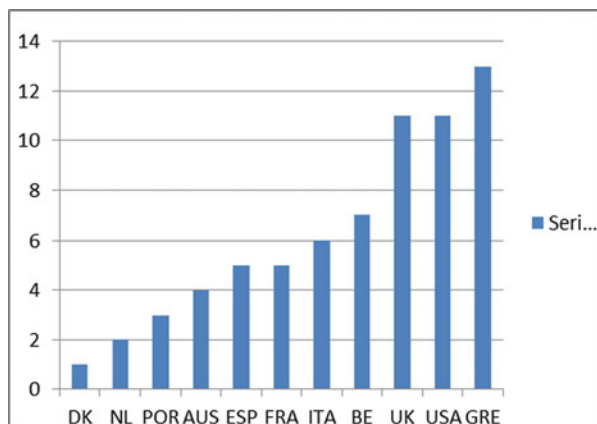
Furthermore, the municipalities' responsibility is to ensure that sewage and rainwater are collected, treated and securely disposed, but the utilities actually implement this task within the boundaries of the municipal sewage treatment plan.

Consumers pay the costs through their water bill, which is based on the 'polluter pays – or full cost recovery principle' – where consumers pay on average 10 USD/m<sup>3</sup> (Fig. 4). Payment covers:

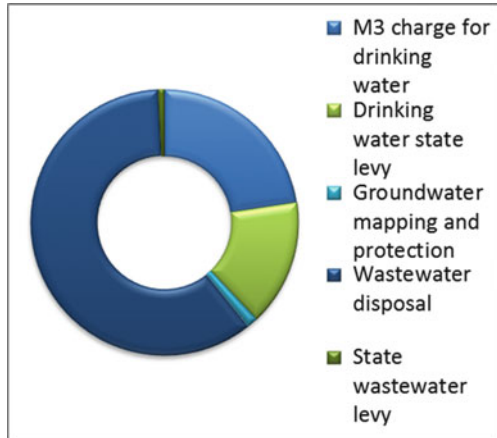
- Drinking water supply
- Wastewater treatment
- Mapping and monitoring of groundwater
- National taxes, also imposed to regulate behaviour and secure water savings
- Elements related to climate change adaptation performed by the utilities

Regulations related to climate change adaptation follow the same pattern, where the Nature Agency establishes the policies and national regulatory frameworks, while the municipalities are responsible for local implementation. Municipalities carry out some elements such as managing water on the roads, and the utilities are responsible for other elements such as managing stormwater in sewers.

**Fig. 3** Number of national agencies responsible for water management (*Source: Authors*)



**Fig. 4** Percent of costs paid by the consumers for various water services  
(Source: Authors)



As a new element, revenue collected through the water bill can fund some activities related to climate change adaptation, possible within an overall financial framework established by the national regulator, the Ministry of Finance.

However, as demonstrated from the cases below, some of the rules related to financing are difficult to manage for the municipalities and the utilities and are a barrier to more integrated solutions as well as more efficient management of stormwater and better climate change adaptation. For example, in the case of the wastewater disposal (charge) cost, it is mostly related to handling of rainwater, which includes costs for infrastructure directing rain away from flooded spaces, such as sewers or channels leading rainwater to green areas.

However, in some situations, the purpose is less easy to define. For example, if the municipality creates an area to contain rainwater and to have recreational functions at the same time, as can be seen in one of our examples below, the payment then can be taken from the wastewater levy. However, it has to be cost-effective, and if some elements have solely recreational purposes such as soccer goals, benches or trees, required funding is by municipal taxes.

This seems clear, but in reality, many uncertainties exist. Trees and bushes around an area may be relevant for preserving a dyke around a rainwater storage tank, but to preserve it and make sure it looks nice for citizens, some gardening and maintenance may be needed and payment for this may be uncertain.

This also applies to new stormwater roads. For example, leading rainwater towards the harbour, a technically very efficient solution, has many uncertainties, e.g. what is necessary for stormwater abstraction; what is needed for the construction of the road; how to deal with privately owned roads, roads owned by the local organisation of property owners or private grounds; and where does some of the water originate. Consideration for health and environment issues is also necessary; stormwater in the open is often polluted by sewage water and water from road

surfaces running into the harbour or into local water bodies, which may be environmentally vulnerable.

## 4 Cases: Cities Facing Different Challenges

Demonstrating some actual challenges, we present three cases from Danish cities. Each city faces different challenges, which are all barriers to more integrated solutions. The cities selected, from a study of 15 different cases, are of general relevance and do not represent challenges specifically related to national, Danish circumstances. In total, the study went through a number of technical issues from 15 large and small cities in Denmark (see Table 1).

We present each case with a short introduction on the technical content and an overview of institutional, legal and financial challenges.

### 4.1 *Climate Change Adaptation in Odense*

General problems are severe flooding during heavy rain and difficulties in implementing sustainable, local drainage of rainwater in a new residential area. In Odense, as well as in all Danish cities, the municipality is the water authority for surface water, wastewater treatment and discharge of wastewater into recipients and for climate change adaptation.

A specific area experienced repeated local flooding following extreme rain events. A newly built sports centre was flooded several times, and a drainage system was constructed (at a cost of around 670,000 €) in order to direct stormwater away from the sports centre. But even after this investment, flooding occurred resulting in significant expenses. For each extreme rain event, costs were estimated ~54,000 € for cleaning of pipes and channels to drain off the water. Extensive impervious surfaces characterise the sports centre, the sewer system could not provide sufficient drainage, so the rainwater was pumped away. The municipality was interested in the more local management and sustainable solutions, but the area

**Table 1** The most pressing technical issues reported from the 15 Danish cities

Technical issues	No. of technical issues
Handling of rainwater from roofs and roads	2
Flooding of roads	2
Discharge of rainwater into streams	1
Flooding of private houses	6
Ensuring good water quality related to climate change	2
Seawater intrusion	2

could not accommodate more local seepage; thus, the water was pumped to the treatment plant.

Another challenge in Odense was a new residential area, developed specifically with the intention of testing local drainage solutions for all the rainwater falling on this area. Technically, it was complicated and coordination was difficult among different stakeholders, e.g. the municipality, utility and property owners. In addition, some stakeholders were not included in the project planning from the beginning. Consequently, knowledge of local stakeholders was not considered, and to reach the most efficient solutions for stormwater, management and local drainage solutions took a longer time.

#### **4.1.1 Institutional Barriers**

Very strict requirements regarding discharge to receiving waterbodies cause conflicts between different entities within the municipality and lead to a discussion on how to regulate the amount of water into the various streams and whether to design for a 10-, 20-, or 100-year event. Getting urban planners, architects, road department, environmental department and others to work together was a challenge, and the division of labour between municipality and utility was unclear.

Climate change adaptation must be included now as an element in local development plans, but in many cases, urban planners have not focused on water and efficient climate change adaptation, but rather focus on large development projects.

The municipality is responsible for environmental and emission permits, but in this case there was not enough time to deal with these tasks.

#### **4.1.2 Financial Barriers**

How is financing for rainwater solutions and how much should be covered by wastewater levies is unclear, even though the crises made the need for more funding obvious. However, overtime, new interventions are more cost-effective than recovery after each rain incident.

#### **4.1.3 Regulatory Barriers**

Municipal sewage plans and climate change adaptation plans must be established alongside development plans. Although such plans are robust and effective instruments, uncertainty exists as to whether they are binding for individuals and water companies. Who exactly pays for the implementation costs is also unclear.

## **4.2 *Flooding of Usserød Stream, Kokkedal, near Copenhagen***

The general challenges in this case relate to local water quality, preventing the flooding of private residences and the need for the establishment of partnerships across administrative boundaries.

Usserød Stream starts at a sluice in a nearby lake, passes through three different municipalities and is, thus, managed by three different water authorities. A sewage treatment plant is located just before the stream enters the City of Kokkedal. When extreme rain occurs, incidents of combined overflows and stormwater overflow from upstream cities discharge into the creek.

Along the stream, private homes were constructed in an old meadow. The first major flood occurred in 2007, but on August 14, 2010, an unexpected cloudburst, between a 500-year and a 1000-year event, took place. An unofficial measurement showed 160 mm rain in a few hours, and within ½ h, basements and living rooms in an area along the river were flooded by water from both streams and sewers.

This flooding led to massive political pressure for obtaining faster results in order to prevent another flooding occurrence, along with the resultant property damage and water quality impact on the stream. It also generated a need for cooperation between the three authorities in the basin area. This posed huge challenges, as not only the three mayors of the municipalities but also the technical directors, urban planners and a large group of other professionals had to cooperate and agree on necessary actions. In this situation, ensuring stakeholder interaction and communication with local citizens presented another complication.

The immediate technical solution to prevent flooding was constructing a double profiled flow of the stream for an event like the one in 2007, but the citizens demanded a more secure dyke funded by the municipality. At first, the authority refused and opined that since the citizens were the main beneficiaries, they should pay for a new dyke themselves. But political pressure changed the decision because local residents were considered particularly vulnerable. Thus, construction funding came from municipal tax revenues.

In addition to the double profiled stream, an external foundation supported a large climate change adaptation project. This project contains elements like the introduction of a skater park that can serve as a rainwater tank and other initiatives to improve stormwater handling while improving recreational facilities in a socially vulnerable area.

### **4.2.1 Institutional Barriers**

The double profiled Usserød Stream project was relatively easy to implement because of political commitment, but moving forward with more ambitious solutions is an additional challenge. Are the interventions a task for the utility or for the municipality's Road and Park Department? What about the environment? There is a

desire to develop and improve residential areas as demonstration projects for the management of stormwater exists, but different solutions are available, and what is not clear is whether they are acceptable for financial and legislative reasons.

Ensuring cooperation among all authorities and stakeholders within the basin has proven quite complicated and revealed a need for institutional models and guidelines to secure basin-wide cooperation, aiming at efficient solutions that are also environmentally sustainable.

#### **4.2.2 Financial Barriers**

For Usserød Stream, funding for the project, obtained from taxes, occurred because of political pressure. Other problems are more forward oriented in connection with the implementation of the upcoming climate change adaptation plan – recreational facilities can serve to delay the water and improve the liveability of socially vulnerable areas. But questions arose: Could the municipality own a skater track? How would this investment be depreciated?, etc. Both the municipality and the utility had concerns about how much to afford without ending up with a conflict about price caps and benchmarking for utilities. Later changes in the water sector legislation brought some clarity and provided an option to fund climate change adaptation projects by wastewater levies.

### ***4.3 Flooding in Stenløse City: Egedal Municipality***

The main problem for the City of Stenløse is that during and after extreme rain events, a local stream floods it. Stenløse stream flows through Stenløse City into Værebros stream, primarily on the surface, but with a few piped stretches. The city contains 37 outlets into the stream, and the river runs through an area with a high degree of imperviousness, many single-family homes and up to two-storey houses. The houses are flooded and homeowners cannot get insurance because of the flood risk.

There is insufficient space in the city to establish open retention basins – only buried or seepage basins, which are very expensive solutions. Because of these technical difficulties, the municipality is beginning to consider construction opportunities outside the city and has identified two options:

- a. Low-lying areas, north of Stenløse City, can be flooded relatively easily during extreme rain, resulting in only little harm to people and property. This could provide a pool volume to accommodate the natural water, which can pass through the city. The municipality has a few areas, north of the city, available, but additional locations require purchase or acquisition through voluntary agreements. Compulsory acquisition is not readily foreseen but may also be an option. A study of the proposed solution made clear that, technically, retaining water in



this way is feasible. Wastewater levies fund this solution, and it saves the utility from making pools and the costs become covered by consumers. Expected costs for the basins are approximately 40 million DKK. However, whether this solution classifies as a technical or an environmental system is unclear and, thus also unclear is who provides the financing.

- b. It may be inappropriate to increase the amount of water passing through the city but many environmental implications exist. Creating a new artificial run of the stream around the city offers another solution and also provides a new natural stream. The existing stream will still be there but downgraded to a stormwater drain, a technical plan. It also provides better possibilities to benefit recreationally from the run of the stream through the city. However, legal and financial conditions for this are unclear. This solution could probably be financed by levies and would be cheaper and prevent flooding more efficiently.

#### **4.3.1 Institutional Barriers**

Institutional barriers relate to difficulties in deciding what can be financed by levies and what can be funded by taxes and what is on private versus public space. Difficulties also exist for the authorities in making decisions when managers, politicians, citizens and utilities are involved. Even though daily working relations are good, many uncertainties occur in regard to roles and rules.

#### **4.3.2 Financial Barriers**

The inability to secure financing for feasibility studies makes it difficult to select the technically best solutions, especially when you do not know which options are available.

#### **4.3.3 Regulatory Barriers**

A regulatory barrier was the unclear legislation with regard to environmental targets according to the Water Framework Directive and the water plans and the exact targets for this, for instance, to set for the utility.

### ***4.4 Present Barriers to More Integrated Solutions***

As can be seen from the cases above – as well as from the overview of all Danish cases – number of constraints make it difficult to find more integrated, and often the cheapest, and technically most efficient solutions. An issue, present in most of the

cases, is the lack of clarity on roles and responsibilities between utilities, different authorities and other stakeholders.

The water sector in Denmark has been going through a number of reforms with the purpose of improving efficient climate change adaptation and management of extreme rain events, but many challenges remain and one of them is the interface between utilities and authorities.

Definitions of different categories related to construction can also be difficult. At times, different types of ownership depend on whether we are talking about establishing a new intervention, running costs or maintenance. It also depends on who is needed to do the job and who can do it best – either utility staff, environmentalists from the municipality or staff from the municipality's Road and Park department.

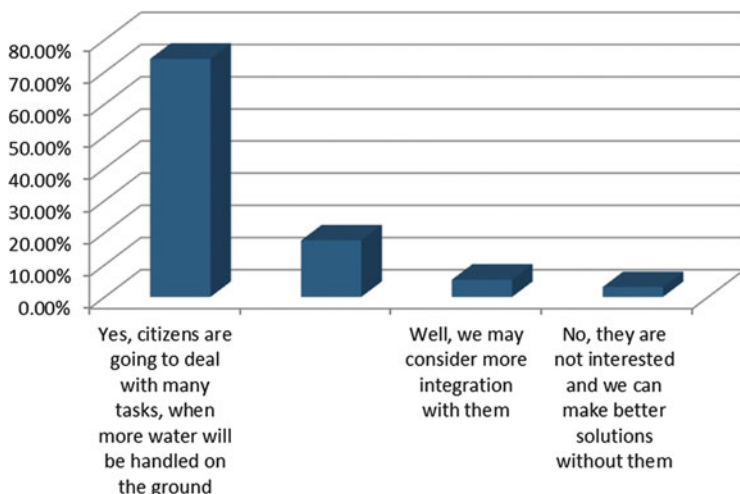
Increased clarity is needed with the different definitions of precipitation. In Denmark, as in many other countries, different targets and rules cover daily rain, cloudbursts and climate change adaptation. How much water is allowed on the ground and how often? When is it legal to use local streams for stormwater? What about environmental concerns and who provides funds if pumping is required to make the solution efficient?

The financial resources for climate change adaptation often pose challenges as well. The utilities have the option to fund interventions by wastewater levies, but in some cases, the construction is more efficient if carried out by the municipality, who may not have the financial resources, human capacity or knowledge to carry out the projects. Large municipalities with more staff have sufficient skills on climate change adaptation, but in smaller municipalities, this may be more difficult.

From 2008 to 2010, many utilities in Denmark transformed from being part of municipal services to private companies, but most are still owned by the municipalities, who are also the majority of the board members. This transfer meant that people, who had been working in neighbouring departments in municipalities, are now working in different companies with different working conditions, tasks and, often, different salaries. In many cities, this transition has been easy and very smooth, but in some cities, severe tensions have resulted in difficult cooperation, which may also lead to inefficient solutions.

Besides cooperation between utilities, the barriers related to connecting municipalities with utilities and ensuring proper planning based on all available knowledge, securing cooperation between different entities within the municipalities presents an issue. Architects, urban planners, environmental specialists and road engineers have different backgrounds and educations and are different types of persons. Securing cooperation between them, even within the same municipality, is often difficult and more so, when they work in different organisations. Most people involved in municipalities and utilities find it important that all stakeholders' views are taken into account.

At the above-mentioned 'Water in Cities' conference, participants were asked about their views on stakeholder integration. To the question – is it vital that we interact more with citizens on climate change adaptation? – 74 % of the respondents



**Fig. 5** Survey results from Denmark on stakeholder integration in urban flood management (Source: Authors)

gave a positive answer, and 5 % gave a relatively positive answer. So, in total almost 80 % are in favour of more stakeholder interaction (Fig. 5).

In spite of these numbers, our research has shown that in reality, this is often very difficult to implement in practice. The Water Framework Directive and the Aarhus Convention on openness in environmental governance prescribe hearings and public information. However, it is often difficult to secure this in practice and actually reach out to citizens, not to mention options for more inclusion, joint decisions making, etc. There are good examples, also from our study, where working with citizens have led to improved solutions, which the technicians had not thought of themselves, but the challenge is to make it work in practice.

Budgeting is another general concern. Municipalities often lack funds and find it difficult to use scarce resources for adaptation to an, often, insecure future. At present, we know that the climate is changing, but it is uncertain how much and with which consequences is uncertain. In our projects, we discussed seeing no-regret solutions as a good starting point focusing on solutions that are efficient and yet relevant. In a neighbourhood in Copenhagen, for example, general upgrading, more open spaces and small parks are needed to make the city greener and more liveable. The chosen solutions have to meet these criteria and at the same time serve as an efficient climate change adaptation. If the expected extreme events turn out to be less severe, the city will still be greener and nicer for inhabitants.

There are many similar solutions in the climate change adaptation plan for the City of Copenhagen, and at present, a number of these solutions are being implemented.

#### ***4.5 Funding of Climate Change Adaptation and Remaining Barriers***

In the summer of 2012, an agreement was made between the government and the municipalities on funding of climate change adaptation in Denmark from 2013 and onwards. This agreement did not provide more funds, but paved the way for funding of more interventions by means of wastewater charges. This also covers projects in streams, projects with higher recreational value and projects where open spaces are used for stormwater management, e.g. a skater park for stormwater storage. This reform gave some clarity, but did not solve all issues.

According to our project group, the following immediate barriers remained after this revision:

- Unclear distribution of roles and the need for more clarity on the cooperation, not just between the municipality and the utility but also between different entities in the municipalities dealing with the environment, roads, urban and water planning, etc.
- Unclear framework for different financial models, the borders between municipalities and utilities and definitions related to the construction of infrastructure, management, maintenance, feasibility studies and who can fund what
- Need for a clearer definition of ‘daily rain’, ‘cloudburst’ and ‘climate change adaptation’ (i.e. when can projects be labelled as climate change adaptation)
- Insufficient resources in the municipality when it comes to planning, handling and construction of tasks related to climate change adaptation and heavy rain
- Insufficient or too late integration of all stakeholders in planning and implementing activities
- Too short timeline for planning, which makes budgeting difficult; often a mismatch between the time, when resources are allocated, and the necessary time to develop the actual projects

#### ***4.6 Proposed Solutions***

Based on these cases, a number of suggestions for improvements that are of a more general nature can be derived, such as:

- A general need for more clear rules
- More precise definition of climate change adaptation, environmental and other targets to ensure that municipalities and utilities know in details which rules and guidelines they should adhere
- Need for funding that is earmarked for climate change adaptation and sustainable urban drainage systems

- Better integration between environmental and technical departments (roads and other infrastructures), architects and engineers, utilities and different public authorities
- More coherent planning, longer time span of projects and integration of all stakeholders and stakeholder organisation
- Improved options to use water as a resource, for recreational and social purposes
- More resources, knowledge and funds for climate change adaptation in municipalities

As can be seen from the next part of this chapter, suggestions from interviews with the stakeholders in our cases correspond with international findings on integrated solutions and what is needed in order to implement these.

## **5 Suggestions to Move Towards Integrated Solutions**

Agreement seems to exist on the need for more integrated solutions and a number of actions needed to implement these. Based on our national and international cases and overviews, we developed a number of recommendations for actions to move towards integrated solutions. These recommendations are based on Danish cases after a number of reforms in the water sector with the purpose of moving towards more integrated solutions. They are also based on Danish legislation, but are expected to be relevant for many countries following the same type of regulation, i.e. based on the Water Framework Directive and other EU legislations. The proposed solutions also integrate lessons learned from international cases wherever relevant.

### ***5.1 Improved Cooperation Between Municipality and Utility***

In recent years, clearly defined roles between municipalities and utilities occur, but strengthening the definition is required in order to handle a changing climate, and clear agreements must be made. As a minimum, clarity is necessary when starting new projects and activities – what are the roles and responsibilities of utilities, municipalities and the different departments in the municipality. In many cases in Denmark, the utility is organised as a private company, but owned by the municipality. When this occurs, clear agreements on a mutual understanding of tasks and implementation ensure better cooperation. When the municipality is the key authority, it is their responsibility to establish and secure good working conditions.

## ***5.2 Cooperation Internally Within the Municipality***

In several municipalities in our test material, the internal distribution of areas of responsibility is often not clear to external nor to internal project participants. What is not well defined is who is responsible for what. All municipalities, who have not already done so, should describe a structure for the definition of roles and responsibilities related to all aspects with regard to climate change adaptation, internally in the municipality. Clarity to external stakeholders then occurs as well – where different tasks are located, including planning and use of local areas.

## ***5.3 Clear Rules on Funding Stormwater Management and Climate Change Adaptation***

In many countries, different sets of legislation and regulation exist depending on whether we are dealing with daily rain, 10-year events, more extreme rain or construction of infrastructure and other measures related to climate change. In Denmark, this causes a lot of uncertainty about who has the authority to do what in different situations, for instance, does a measure relate to climate change adaptation or usual stormwater management?

A set of new guidelines has been adopted in Denmark, giving some clarity on these issues – in particular with regard to funding – but a number of challenges remain. Two examples:

- The municipality is responsible for the planning of climate change adaptation and they own the projects, but most often, the technical expertise lies with the utilities, who are responsible for stormwater management. How to fund interventions, which – from a technical point of view – are accomplished most efficiently by utilities, can be difficult if there is not a good cooperation between the two entities. Clear rules and definitions for different categories of rainwater management and their funding would ensure that the most efficient solutions are utilised, even in cities with a more complicated cooperation between partners.
- The new Danish guidelines demand that all solutions must be cost-effective. In many cases, as can also be seen from the climate change adaptation plan in Copenhagen, the best and most cost-effective solutions are sought in a combination of traditional handling of water in the sewer system and more innovative solutions, where water is handled in the open landscape and can serve recreational purposes, while also functioning as climate change adaptation. If the management is split between different institutions, it can be difficult to calculate which combination of different interventions is the most cost-efficient solution.

Therefore, a clear recommendation is that the authorities must define exactly which types of legislation should apply to which interventions.

#### ***5.4 Insurance Systems to Improve Climate Change Adaptation***

International experiences from Great Britain, among other countries, demonstrate clearly that many interventions related to climate change adaptation are taking place on private property. In order to promote the responsibility of the citizens and their participation in achieving the best solutions, it is important that authorities develop incentives to promote climate change adaptation at the household level, as this will ensure the most efficient solutions in many cases. In some countries, a number of incentives are actually related to insurance schemes, where incentives promote cheaper insurance policies for houses that are climate proof. Collective systems can also make it easier for vulnerable areas to obtain insurances.

#### ***5.5 Improved Coherence Between Policy Areas***

EU legislation is the pillar for water management in EU member states and is based on different directives such as the Water Framework Directive, the Flood Directive, the Waste Water Directive, the Bathing Water Directive and directives on marine waters. Experiences from a number of our cases demonstrated local needs for interventions based on integration across policy areas, where demands to comply with the Water Framework Directive can go hand in hand with compliance with other directives.

Nationally authorities can promote more integrated solutions by promoting coordination and cooperation and by providing clear guidelines on how to implement these locally.

At the local level, municipalities, utilities, regions and cooperation arrangements between municipalities across administrative boundaries must work in order to promote better linkages between cities and their catchment areas. For example, when planning new residential areas, required decisions include plans for sewage treatment and stormwater runoff.

#### ***5.6 Improved Cooperation Across Catchments***

International experiences demonstrate clearly that water management and climate change adaptation are most efficiently ensured based on the catchment areas, but in some countries such as Denmark, this is only implemented to a minor extent. Moving towards more catchment-based management is vital for more integrated and efficient solutions. International experiences provide a number of examples of such mechanisms:

- Improve cooperation between local bodies/organisations on climate change adaptation in the catchment; many examples of such cooperation exist across Europe.
- Within a catchment, one municipality is appointed to be responsible for cooperation mechanisms.
- Decentralised, national management structures can promote cooperation.
- Local cooperation based on risk mapping – areas close to each other, which are facing risks – must cooperate on climate change adaptation.

The exact mechanisms are less important as long as catchment-based management is improved.

### ***5.7 Improved Stakeholder Integration***

Based on the Aarhus Convention, the European Water Framework Directive includes demands for more inclusion of stakeholders in local decision making with regard to water management. As demonstrated clearly by our cases, there is a broad recognition among stakeholders in Denmark (and throughout Europe) that improved management of stormwater and extreme events depends on improved dialogue with citizens to ensure that local challenges and conditions are well known. This also ensures that the most cost-efficient solutions – for citizens as well – are implemented, also when this is best implemented on private property.

However, realisation exists regarding a number of challenges related to stakeholder integration. In terms of communication, it is often difficult to reach out and communicate the frequently quite complex challenges and options for stakeholders, who have an interest, but sometimes a limited technical knowledge.

Many cities also experience that only a limited number of citizens are actually interested in participating, whereas others – like the Climate City Middelfart [8] – have managed to include large stakeholder groups in climate change adaptation by focusing strongly on them. In Great Britain and Germany, there are also good examples of citizens' involvement and commitment in partnerships with utilities and authorities.

For stakeholder integration to become successful, it is important to learn from good national and international examples. We recommend that key players among organisations and authorities in the water sector develop recommendations and guidelines for stakeholder integration based on best practices at national as well as international level.



## ***5.8 Climate Change Experiences and Evaluation of Projects***

Finally, we recommend from our projects to make systematic collections of experiences and evaluations in order to base future projects on best practices. In many cities in Denmark, Europe and all over the world, a large number of projects on climate change adaptation are currently being implemented and learning from each other's experiences is essential. Internationally, it is therefore highly recommended that organisations and utilities participate in cooperative activities and share their best practices – in particular within the EU, where the same overall regulatory framework is guiding activities.

At the national level, our studies have demonstrated that within the country, a need exists to compare projects and solutions to benefit from the lessons learned by others in order to move towards more efficient solutions. In many cases, however, it is difficult to compare the experiences, as there are many different methods and ways to present lessons learned. Therefore, we recommended that authorities in Denmark, as well as in other countries, develop a framework for sharing lessons learned in a systemic and coordinated manner.

## **6 Cases: What Can Be Achieved?**

Having taken a look at governance models, challenges and recommended solutions for more efficient and integrated water management, we will now present some of our lessons learned in terms of implementation of projects to demonstrate some examples of what is possible to achieve based on a combination of technologies, governance models and political commitment to secure better water management.

### ***6.1 Integrated Management Solutions: Aarhus, Denmark***

This case demonstrates how holistic approaches to upstream/downstream surface water, sewage treatment, water quality improvements and flood control improved urban water quality – also for recreational waters – and saved the city EUR 701,000 per year. Increasing efficiency, saving money, and reducing the environmental footprint were the outcomes of a project implemented by the City of Aarhus to move towards integrated urban water management.

The City of Aarhus, Denmark's second largest city and principal port, is in the process of restoring the old harbour area into residential and recreational areas. Local politicians also wish to improve water quality in the city and the surrounding area for improved bathing facilities and to reopen a cased river running through the old city centre in order to make the city more lively and welcoming.

In order to do so – and also to live up to the EU Water Framework Directive and Bathing Water Directive – the city and its utility, Aarhus Water, sought new solutions that would be based on integration of different elements of urban water management and different models for doing so:

- The rural, upstream catchment
- Water in the sewer systems
- The lake just outside the city centre, which runs into the river through Aarhus
- The harbour and bathing areas in Aarhus

One of the key challenges was that the city faced a serious need to increase its wastewater treatment efficiency and capacity in order to avoid flooding and poor water quality in a stream passing through Aarhus and to improve bathing water quality at the city's beaches. Adding new machinery and tanks was the traditional solution, but it would have added a significant burden to the city's finances. Therefore, the city looked for a new approach that could be cost-efficient, provide annual savings and be easily maintained by Aarhus water's own staff (the water utility of Aarhus is a private utility owned by the municipality).

Aarhus Water is a water supplier and storm- and wastewater service provider to Aarhus Municipality and its 310,000 residents. The water utility operates four large and six small wastewater treatment plants (WWTPs), which together receive approximately 35 million m<sup>3</sup> of wastewater per year. To live up to the requirements of the City of Aarhus, they faced a growing need to expand the capacity of its plants to handle the increasing volumes of wastewater.

Aarhus Water wanted to increase the efficiency and the capacities of their four large WWTPs and at the same time reduce the energy consumption and effluent values without any major investments in the treatment plants themselves. They also wanted to be able to calculate exactly which costs would result in the expected results, yearly cost savings and return of investment period, before implementing any measures.

The answer to these requirements was to implement process optimisation, thereby allowing the WWTP to operate at its maximum. To evaluate different process optimisation measures and to come up with a priority list of measures, DHI was asked to create a prioritisation methodology in close cooperation with Aarhus Water that combined general process knowledge with local knowledge of daily operations at the specific treatment plants.

Process optimisation was achieved by real-time monitoring of the processes and automatically fine-tuning the processes to operate efficiently during variable conditions. This solution did not require any major construction work, but only the purchase of new sensors used for automated set point control with the Data Integration and Management System (DIMS), a DHI solution software. The staff of the four WWTPs actively supported the project implementation in order to increase staff competencies and allow for future maintenance and further development after the formal project completion.

**Table 2** Economic results of process optimisation at the four major WWTPs operated by Aarhus Water

Economic results		Marselis	Egaa	Viby	Aaby	Total
WWTP size	PE	200,000	120,000	83,000	84,000	487,000
Savings on energy and chemicals	EUR/year	73,000	31,000	40,000	132,000	276,000
Reduced effluent values – lower effluent tax	EUR/year	114,000	19,000	27,000	2000	162,000
Increased capacity – depreciation 25 years	EUR/year	54,000	50,000	132,000	27,000	263,000
<i>Total</i>	<i>EUR/year</i>	<i>241,000</i>	<i>100,000</i>	<i>199,000</i>	<i>161,000</i>	<i>701,000</i>

Effluent tax in Denmark (2010/2011) is 1.48 EUR/kg BOD, 2.68 EUR/kg TN and 14.77 EUR/kg TP

### 6.1.1 Achieving More with Less

The value of the optimised system was apparent with annual savings of EUR 701,000. The economic results shown in Table 2 below were better than originally estimated.

Other elements in this integrated solution were the implementation of a real-time urban water monitoring, control and warning system with improved control of the water volumes in the sewer system of the city. This minimises the amount of stormwater overflow in the city and consequently less water reaches the recreational areas without being treated. The improved warning system is operated based on information about future precipitation from a local area weather radar, which provides water managers with information about future rainfall, the need to close down the bathing facilities, and when it will be secure to open them again.

Thanks to the implementation of the process control, Aarhus Water was able to extend the WWTP capacity and reduce flood risks, save energy and chemicals – and reduce the associated costs – and decrease effluent values, which has contributed to the fulfilment of the EU Bathing Water Directive in Aarhus.

Furthermore, effluent values are now highly predictable according to real-time monitoring systems. This curbs the WWTP's CO<sub>2</sub> emissions and ultimately minimises the burden on the environment. With just minor investments and the implementation of the process control, the WWTP has achieved increased process stability and has become more robust, enabling it to cope with variable conditions (e.g. inflow amount and composition, weather, etc.).

This integrated approach, where urban water is linked to water in the whole catchment and where sewage and stormwater are managed with a holistic perspective to include both water quality and quantity aspects, has improved the overall water quality in and near Aarhus, which was one of the political arguments for introducing the project.

## ***6.2 Urban Flooding in a Low-Lying Area: Greve Municipality, Denmark***

The Municipality of Greve is a flat and low-lying, coastal area, south of Copenhagen, Denmark. In recent years, it has been exposed to increasing rainfall intensities as well as sea level rise due to climate changes. Following severe flooding of private houses, companies and other buildings as well as infrastructure in 2002 and 2007, it became a key concern for the local city council to avoid a reoccurrence as it created very challenging situations for inhabitants in the most affected areas such as insurance problems and difficulties related to selling real estate. To overcome the situation, the municipality launched a strategic project to implement climate change adaptation measures and develop warning systems and emergency plans.

To prevent future flooding, a number of technical solutions were implemented. It was necessary to establish storage capacity for stormwater overflow to prevent it from entering the cellars of private houses. It was also important to use local structures such as streams and lakes as basins, but some organisational, financial and environmental challenges existed in establishing the regulatory framework and finding out, for instance, how much stormwater to discharge into the local receiving water bodies without causing damage to the environment.

A linked challenge was flooding caused by seawater intrusion due to rising seawater levels or caused by storms. Furthermore, the city also witnesses rising groundwater levels near the surface, in particular in the coastal areas, which created a need for draining and other measures to prevent groundwater from entering the sewers and the treatment plants, which would be very costly.

To overcome the combined challenges, the local utility and the city council developed an integrated strategy for simultaneous management of extreme rain, urban flooding and rising seawater with a combination of measures: warning systems, risk mapping, improved pumping and control of the sewers and establishment of barriers to prevent stormwater from running from sewers into private homes. Establishment of dykes to block incoming seawater is another part of this solution.

Analyses of risks and options for mitigation was also an important part of the activities, and hydrological models were developed for the entire surface water catchment. These models were able to simulate the observed flooding patterns quite accurately and helped understand the complex interrelation between upstream and downstream conditions in the catchment. Measures to prevent or minimise future flooding incidents were optimised during scenario runs, and an on-line, web-based flood forecast system was developed for daily operation.

Based on the holistic perspective, it was also possible to propose alternative solutions such as flooding of a local football field to avoid flooding of the city hall.

In 2010, the established, integrated solutions, in fact, prevented flooding. During the first 2 weeks of August 2010, heavy and high-intensity rain events hit several locations in Denmark with subsequent severe flooding. The rainfall intensities exceeded the Danish design standards. This was also the case in the area of the

Municipality of Greve, where more than 100 mm rain was recorded in just a few days, but the staff of the utility and the Municipality of Greve managed to handle these heavy rainfall events with only minor damages. As an example, the municipality was able to analyse different options and via installed data management systems to get detailed information about the current position of the water in the system, which provided the basis for staff decisions on how to operate the drainage system.

During flooding, the utility of Greve is now able to secure a complete overview of the situation and control the flow, so flood damages can be limited. Further, the citizens have received updated information from websites or text messages during the critical stages of the heavy rainfall events.

### **6.3 Securing Safe Bathing Water: Copenhagen, Denmark**

Copenhagen, the capital of Denmark, boasts about attractive beaches and safe water. This draws tourists to the city and consequently serves to boost the nation's tourism industry. The city has succeeded in providing recreational bathing areas to local citizens and visitors in the very heart of the city.

Copenhagen's harbour faces the same threats related to water quality as any other harbours – heavy rainfall, frequent release of sewage water and induced pathogenic bacteria. Efficient stormwater mapping, monitoring and treatment systems have been implemented, but in cases with heavy rain – particularly in the summertime – it is difficult to completely prevent pollution from stormwater overflows and to avoid the use of unsafe bathing water. Therefore, the city in collaboration with the Greater Copenhagen Utility and a number of companies, including DHI, developed an innovative bathing water forecast [BWF] system. This system completely transformed the city's harbour, and today the downtown swimming area is a popular leisure destination where visitors can swim safely without having to worry about contracting waterborne diseases.

The solution achieved by an integrated bathing water forecast system, combining real-time water quality monitoring, accurate forecasting tools and user-friendly dashboards was designed to meet the stakeholders' different needs for information, which is also provided by a bathing water app. The forecast system uses dynamic models providing detailed information, as well as early detection of pollution threats and a reliable forecast of water quality. By means of the forecasting system, the city reduces undesired closure of the harbour's public baths to a minimum.

The bathing water system constantly monitors the harbour's water quality and predicts the concentration of indicator bacteria, *Escherichia coli* (*E. coli*) and *Enterococci*, at specified locations along water courses from the city to the harbour. To help forecast frequent pollution threats, DHI also collects meteorological data from forecast suppliers and runs hydrodynamic models to retrieve data. All this information creates models to predict the water quality in the harbour.

Once the on-line data is collected, the BWF system relies on MIKE 11 together with MIKE 3FM to model the inflow of waters from the city into the harbour. ECO lab (DHI's water quality modelling software) processes these hydrodynamic models, combined with the measured and modelled pollutions, to produce a complete predictive pollution forecast. The software utilises actual information on meteorological forecasting, combined with precise hydrodynamic models, and simulates the fate of the indicator bacteria based on various factors, such as water temperature, salinity and solar radiance. Hence, the model system is a highly effective tool to assess and identify the best method to address solutions to maintain water quality and reduce risk of pollution.

A key element of the system is that the public must be able to trust the forecasts and feel safe about bathing in the harbour. For this reason, anyone, who intends to use the harbour bath reliable information, can access, and the system alerts via text messages to provide an early warning when water quality drops. Likewise, a notification is sent out when the water is safe again.

Based on this holistic approach to improving urban water quality, Copenhagen harbour has been transformed from an industrial port to a cultural and social centre in the city, where residents can swim in the harbour baths or in nearby beaches, fish, sail and in general take advantage of the clean water in Copenhagen.

#### **6.4 Control of Urban Waterborne Infectious Disease: Dhaka, Bangladesh**

Bangladesh is a densely populated developing country. Citizens of Dhaka, the capital of Bangladesh, often face flooding and severe storms and exposure to severe health risks because of the proximity of polluted surface waters. Urban water managers in Dhaka were facing the need to manage the increased threat to water infrastructure related to climate change and needed to incorporate for climate change adaptation solutions that take into account health-related risks. They sought a solution by combining classic hydraulic sewer network modelling and surface modelling with a quantitative microbial risk assessment to allow for holistic water planning that takes into account health risk aspects.

Diarrheal diseases such as cholera, typhoid, rotavirus and *E coli* (ETEC) cause two million deaths – or 5 % of the global mortality – every year. For children under 5 years, this number is 1.2 million deaths (9 % of global mortality). The city urgently needed to reduce the burden of diarrheal diseases, particularly for children under the age of 5. Waterborne diarrheal diseases are transferred to humans via drinking water or direct exposure to surface waters such as flood or recreational water. These diseases generally observed in developing countries, particularly in slum areas that flood more frequently. Even in countries with fully developed water infrastructure, transmission of waterborne infectious diseases still occurs via these

same sources. With climate changes, the health risks for both developed and developing water infrastructures will become more evident.

#### **6.4.1 Intelligent Water Management and Disease Control**

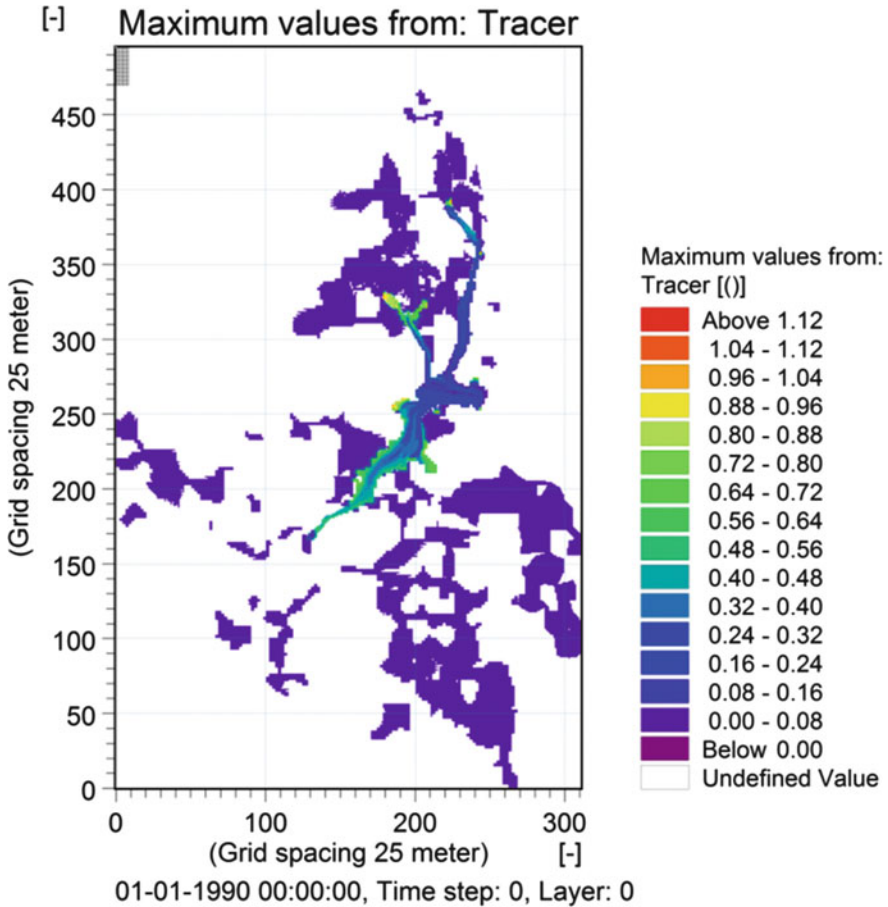
At DHI, we developed a concept for intelligent water management to reduce waterborne infectious diarrheal diseases caused by contact with surface waters. Our concept identifies locations and situations with the highest risk. This allows water managers to prioritise and intervene in the economically most optimal way, which will result in the highest impact on public health. We combine the use of one-dimensional drainage and sewer models with two-dimensional surface models to estimate flood levels and the concentration of wastewater and pathogenic microorganisms. The flood model results, used as inputs to assess human exposure to the pathogens and quantitative microbial risks, help determine the burden of disease on the population when cities flood. The model identifies critical control points for interventions to reduce the disease burden. The interventions may be diverse and include, among other things, intelligent pumping strategies, structural changes of the sewer/drainage systems, improved distribution systems and sanitation, restriction of access, risk communication and vaccination in high-risk areas.

Investments in water infrastructures to decrease waterborne infectious diarrheal diseases and to increase resilience to climate change are expensive. To attract the necessary funds and achieve the highest possible effects of the investments, a thorough planning and analysis of scenarios is necessary. At the same time, authorities must ensure that the investments themselves do not create another health risk.

Human health and diarrheal diseases are important parameters included during the planning process. This water management concept provides water managers with the best available information to identify the most critical points and support decisions regarding interventions by:

- Mapping water infrastructure.
- Setting up models for the area of concern.
- Determining and/or estimating surface water qualities.
- Determining drinking water qualities.
- Estimating infection risks and disease burden.
- Determining critical disease control points in time and space.
- Analysing scenarios to estimate the effects of interventions. The scenarios may include future climate scenarios with increased frequency of heavy rain.

The hydraulic model is useful for other purposes, including daily operation of sewer systems, urban development and climate change adaptation. Our approach introduces a new understanding and awareness of the importance of risk management. By applying the described concept, water managers increase the possibilities of attracting necessary funds to intervene by providing credible scenario analyses and estimations of interventions' effectiveness. Using this tool requires the



**Fig. 6** The pollution map computed for the flood in September 2004. The map shows the dilution factor for wastewater in the floodwater. The dilution factor of the wastewater concentration represents the concentration (*Source: Authors*)

availability of a sewer and a surface model or models in development. Our tool uses the deterministic model MIKE FLOOD, which integrates the one-dimensional hydraulic advection-dispersion module (A/D) sewer network model in MIKE URBAN and the two-dimensional hydraulic surface A/D model in MIKE 21. Figure 6 demonstrates an example of the computed amount of wastewater in the floodwater.

This case from Dhaka, Bangladesh, demonstrated how an integrated approach, where health risks, flood risks and surface water modelling are included together, contributes to improving public health and to control urban waterborne infectious diseases. This generated better health and living standards in Bangladesh. Here, it also serves as an example, demonstrating that even in the case of developing countries with numerous challenges, a holistic approach where managing water



quality together with surface and stormwater management provides efficient solutions. It also demonstrates that advanced modelling tools contribute to the development of efficient solutions in developing countries.

## 7 Conclusion

In this chapter, we examined some of the features that define integrated solutions such as integration of water quality and water quantity. Coordination is also vital for integration – coordination between cities and catchments, upstream and downstream users and within different planning areas. For instance, it is important that physical planning and water planning are coordinated. A similar element is that water is managed by only one entity, whether it is a municipality, a water company or a local administrative entity. The lowest appropriate administrative level handles this management, but public participation as well as stakeholder inclusion is also very important for more holistic solutions.

Water as an economic value, which must be managed accordingly, the ‘polluter pays principle’ and the idea that solutions must not only look into economic but also environmental and social conditions are a number of overall principles.

We presented international experiences and a model developed by the World Bank, which also emphasises the need to link land use, water use and flood and drought management and to consider urban development, water services and green cities in combination.

When facing real-life challenges, there are a number of reasons, why more integrated solutions are difficult to handle and often do not provide the integrated framework, not even when local politicians and decision makers are interested in more integrated solutions. The feedback from 15 Danish cities collected and presented pointed out some of the challenges they face in order to develop more integrated and efficient solutions such as the unclear distribution of roles and the need for more cooperation between all stakeholders working on urban and water planning, flood proofing and climate change adaptation. What may be a bit surprising is that even cooperation within the same organisation may be difficult, for instance, between water managers and urban development planners.

Other challenges are a lack of coordination upstream and downstream as well as too little stakeholder integration. At the international level, we highly recommend that organisations and utilities participate in cooperation activities and share their best practices – in particular within the EU, where the same overall regulatory framework is guiding activities. At the national level, our studies have demonstrated that also within the country, comparing projects and solutions is necessary to benefit from the lessons learned by others and to move towards more efficient solutions.

Sharing the examples here is also an element in such a knowledge sharing effort, and therefore we have presented four cases, where we have participated in the development of integrated urban solutions. From Aarhus, an integrated approach

demonstrated that the urban water links to water in the whole catchment, where sewage and stormwater are managed holistically. This was financially efficient and has improved stormwater management and overall water quality in and near Aarhus. In Greve, integrated solutions demonstrated the ability to prevent flooding and develop efficient warning systems, when flooding is unavoidable. Citizens participated in the discussions and during the critical stages of the heavy rainfall events, and the citizens have received updated information from websites or text messages. In Copenhagen, the holistic approach to improve urban water quality ensured clean water in the harbour area and has contributed significantly not only to the establishment of public baths but also to the general transformation of Copenhagen into a more clean and liveable city. In Dhaka, Bangladesh, we demonstrated how an integrated approach, even in a poor developing country, contributed to improving public health as well as better health and living standards. Furthermore, we demonstrated that advanced technologies and modelling tools are not too complicated for a developing country but will also contribute to widen the knowledge base and thus enable more efficient solutions.

Recalling, for instance, the model from the World Bank, one might think that truly integrated approaches demand integration of all elements in urban water planning and management – drinking water, sewage, stormwater, catchment management, water environment, urban planning, infrastructure development, etc. This has not been the case in any of the solutions described in this article, but nevertheless the aspiration has been there and integration of some of the elements has taken place. It therefore seems relevant to look at integrated urban water management as a process, where it will often be impossible to reach a perfect integration of all elements. However, it is also clear from our case studies that the process, the holistic approaches and integration of some of the key urban water management elements lead to more efficient urban water management in terms of economy, environment and safety for the people involved.

## References

1. 7th World Water Forum 2015: action monitoring system. [http://ams.worldwaterforum7.org/progress.asp?s\\_theme\\_cd=010070](http://ams.worldwaterforum7.org/progress.asp?s_theme_cd=010070). Last day accessed 1 Dec 2015
2. Vand i byer – Innovationsnetværk for klimatilpasning: Afsluttede innovationsprojekter. <http://vandibyer.dk/innovationsprojekter/afsluttede-innovationsprojekter/>. Last day accessed 23 Nov 2015
3. Vand i byer – Innovationsnetværk for klimatilpasning: IP09 – Integreret forvaltning af vand i byer- analyse af institutionelle, lovgivningsmæssige og finansielle aspekter. <http://vandibyer.dk/innovationsprojekter/afsluttede-innovationsprojekter/ip09-integreret-forvaltning-af-vand-i-byer-analyse-af-institutionelle-lovgivningsmaessige-og-finansielle-aspekter-1/>. Last day accessed 23 Nov 2015
4. Closas A, Schuring M, Rodriguez D (2012) World Bank Study: integrated urban water management – lessons and recommendations from regional experiences in Latin America, Central Asia, and Africa. World Bank Study, WPP case profile/no. 1 Nov 2012. <http://water.worldbank.org/sites/water.worldbank.org/files/publication/water-wpp-IUWM-Lessons->

- [Recommendations-Regional-Experiences-Latin-America-Central-Asia-Africa-high.pdf](#). Last day accessed 23 Nov 2015
5. Organisations for Economic Co-operation and Development (OECD) Programme on Water Governance. <http://www.oecd.org/env/watergovernanceprogramme.htm>. Last day accessed 23 Nov 2015
  6. International Water Association (IWA). Cities of the future – water security for cities through integrated design and water centric decision making. <http://www.iwa-network.org/projects2/cities-of-the-future>. Last day accessed 23 Nov 2015
  7. 7th World Water Forum 2015: Europe region process. <http://www.world-water-forum-2015-europa.eu/>. Last day accessed 23 Nov 2015
  8. ‘The Climate City’ project in Middelfart. <http://www.klima-byen.dk/the%20climate%20city>. Last day accessed 23 Nov 2015

# Carbon Footprint of Water Consumption in Urban Environments: Mitigation Strategies

Tamim Younos, Katherine O'Neill, and Ashley McAvoy

## Contents

1	Introduction .....	34
2	Nexus Between Water and Energy in Urban Environments .....	35
3	Carbon Footprint of Water Consumption .....	35
3.1	Electricity Use and Carbon Dioxide Emission .....	35
3.2	Carbon Footprint of Urban Water Infrastructure: Case Study .....	36
4	Mitigation Strategies .....	38
4.1	In-Building Water Conservation .....	38
4.2	Water Utility Energy-Use Efficiency .....	39
4.3	Decentralized Water Infrastructure .....	44
4.4	Integrating Renewable Energy Use and Water Infrastructure .....	48
5	Conclusions .....	53
	References .....	54

**Abstract** Energy demand for water consumption continues to increase globally due to population growth and expanding water infrastructure in urban areas. Energy consumption attributed to water services in urban areas constitutes a significant portion of total energy resources around the world. Since energy is mostly extracted from fossil fuels, urban water infrastructure can be a major contributor to global CO<sub>2</sub> emissions. Worldwide, a significant need exists to develop mitigation strategies for reducing the carbon footprint of water consumption, thereby mitigating climate change. This chapter provides an overview of the nexus between water and energy in urban areas and estimates energy consumption in urban water infrastructure and the associated carbon footprint of water consumption. Specific mitigation strategies for reducing the carbon footprint of water consumption discussed in this chapter include water conservation measures, energy-use efficiency in municipal

---

T. Younos (✉)  
Green Water-Infrastructure Academy, Washington, DC, USA  
e-mail: [tyounos@gmail.com](mailto:tyounos@gmail.com)

K. O'Neill • A. McAvoy  
Environmental Studies Program, Roanoke College, Salem, VA, USA

water utilities, and the potential for decentralized water infrastructure in reducing energy consumption. Finally, the chapter discusses the potential for integrating renewable energy resources into urban water infrastructure in order to reduce dependence on fossil fuel-based energy and, thus, reduce the carbon footprint of water consumption.

**Keywords** Climate change • Decentralized water infrastructure • Energy-use efficiency • Renewable energy use • Water conservation • Water infrastructure

## 1 Introduction

According to the US Census Bureau, 80.7 % (2012 data) of the US population currently resides in urban areas – defined as densely developed residential, commercial, and other nonresidential areas [1]. Furthermore, the World Health Organization (WHO) estimates that the urban population in 2014 accounted for 54 % of the total global population, up from 34 % in 1960, and is expected to grow approximately 1.84 %/year between 2015 and 2020, mostly in developing countries [2].

Increased urbanization and population growth has exerted significant demand to expand and enhance water infrastructure and water sector services from potable water supplies associated with wastewater treatment and discharge to urban stormwater runoff drainage. Characteristics of conventional urban water structures include: (1) centralized and large-scale systems that serve large areas and populations, (2) dependence on water supplies from water sources outside urban boundaries, (3) generation of significant volumes of wastewater for disposal, (4) generation of runoff from paved urban areas that flow into surface waters, and (5) extensive pipe networks that deliver potable water to consumers along with drainage networks that transport wastewater and stormwater runoff to wastewater treatment plants and surface waters away from population centers. Major impacts of urban water use and centralized water infrastructure include surface water pollution, groundwater table decline, and saltwater intrusion in urban and coastal aquifers. Furthermore, urban water infrastructures use significant amounts of energy, much of which originates from fossil fuels, a major source of atmospheric carbon dioxide.

This chapter provides an overview of the water and energy nexus in urban environments, with emphasis on the energy consumption requirements for potable water and wastewater treatment, energy costs associated with water distribution via pipelines, and the associated carbon footprint of water consumption. Mitigation strategies for reducing the carbon footprint of water consumption discussed in this chapter include: water conservation measures, energy efficiency in municipal water utilities, and the potential effects of decentralized water infrastructure. Finally, the

**Table 1** Percent of total energy use in water service sectors in selected world cities [7]

Geographic location	Water service sector	Approximate percent total energy used in water service sector
Toronto, Canada	Potable water and wastewater	2
India (various cities)	Potable water and wastewater	<3–16
USA (overall)	Potable water and wastewater	4
State of California (USA)	Potable water and wastewater	19
State of Texas (USA)	Potable water	0.5–0.7
China	Potable water	0.5
Spain	Potable water	5.8

chapter discusses the potential for integrating renewable energy resources within urban water management to reduce both the dependency of urban water infrastructure on fossil fuel-based energy and the carbon footprint of water consumption.

## 2 Nexus Between Water and Energy in Urban Environments

Urban water infrastructure around the world consumes a significant portion of global energy resources (Table 1). For example, in the USA, about 56 billion kilowatt hours (kWh) or 4 % of total national energy consumption is attributed to water and wastewater services [3]. The energy used for water treatment and delivery in the USA is reported to be in the range of 0.07–0.92 kWh/m<sup>3</sup> with an estimated average of 0.38 kWh/m<sup>3</sup> [4, 5]. The energy demand for water infrastructure is projected to increase by approximately 30 % over the next decades, partially due to the need for using energy-intensive alternative water sources such as saltwater and reclaimed wastewater for potable purposes to meet increased urban water demand [6].

## 3 Carbon Footprint of Water Consumption

### 3.1 Electricity Use and Carbon Dioxide Emission

At present, world communities significantly depend on fossil fuels (coal, petroleum, and natural gas) to generate electricity for water treatment and distribution. Table 2

**Table 2** Carbon dioxide emissions from electric power generation and water delivered [5]

Fuel type	CO <sub>2</sub> output rate (kg/kWh) electricity generation	Approximate CO <sub>2</sub> output (kg) (per m <sup>3</sup> of water delivered)
Coal	0.960	368
Petroleum	0.868	333
Natural gas	0.596	228

shows carbon dioxide (CO<sub>2</sub>) emissions attributed to electricity generation from fossil fuels as a function of the volume of potable water delivered to consumers [5].

### 3.2 Carbon Footprint of Urban Water Infrastructure: Case Study

The potential for energy and carbon savings in urban infrastructure can be illustrated by a case study from the town of Blacksburg, Virginia (USA). Blacksburg is a university town located in the mountainous areas of Southwest Virginia [8]. The mountainous terrain is a notable factor in this study, as energy use for water distribution and pumping is highly dependent on the topography of the area. The 2012 US Census Bureau recorded Blacksburg's population as 42,749, not including the transient student population. With 170 residential/academic buildings, the university's (Virginia Tech) main campus in Blacksburg resembles a microcosm of a high-density urban area.

Approximate water consumption in Blacksburg and Virginia Tech is  $11.4 \times 10^6$  m<sup>3</sup>/day (3.0 MGD). The water treatment facility operated by the Water Authority is located about 13 km from the town of Blacksburg. Pumps are used to lift source water uphill 107 m from the New River intake and transport it to a conventional water treatment facility located about 3.7 km from the intake. After treatment, the water is pumped to a high head storage tank  $7.57 \times 10^6$  m<sup>3</sup> (2.0 MG) capacity and then delivered to the town of Blacksburg by using a booster pump station. Wastewater from the town is collected in a central location and transported to a biological wastewater treatment plant by gravity flow. The average wastewater load to the wastewater treatment facility is  $18.4 \times 10^6$  m<sup>3</sup>/day (4.85 MGD).

The amount of electricity used to treat water and wastewater depends on the quality of the water, i.e., the energy required to treat wastewater is higher than the energy required to treat freshwater. The energy required to transport potable water and wastewater is site specific and varies depending on transportation distance and topography (land slope). For this study, 3 years of electricity use data (2003–2006) for the water treatment plant and pumping stations were obtained from the Water Authority. Electricity use for wastewater treatment was obtained from the wastewater treatment facility. Results are summarized in Table 3.

**Table 3** Electricity use for water infrastructure in Blacksburg, Virginia

Water infrastructure	Capacity m <sup>3</sup> /day (MGD)	Electricity use (kWh/m <sup>3</sup> )
Potable water	11.4 × 10 <sup>6</sup> (3)	0.44
Wastewater	18.4 × 10 <sup>6</sup> (4.85)	0.70

**Table 4** Carbon footprint associated with water consumption in selected buildings, Blacksburg Virginia (USA)

Building name	Water consumption m <sup>3</sup> /year (gal/year)	Electricity use (kWh)	CO <sub>2</sub> output (kg/year)
The YMCA Center Blacksburg	460 (121,500)	180	175
Whittemore Hall (Academic Building), Virginia Tech Univ.	5377 (1,420,700)	2136	4521

The 0.44 kWh/m<sup>3</sup> electricity use (Table 3) shows the combined electricity required for water treatment and delivery (via pressurized pumps). In this Blacksburg case study site, about two-thirds of the energy used for drinking water was attributable to pumping and delivery and the remaining one-third attributable to water treatment. Although the ratio of energy use for water treatment and distribution is site specific, in general, energy demand for water treatment is much lower than water transportation demand.

Since approximately 10 % of electricity use in Blacksburg originates from hydropower, estimated total energy use attributed solely to coal is 10 % lower than 0.44 kWh/m<sup>3</sup>, i.e., 0.40 kWh/m<sup>3</sup>. Total carbon dioxide (CO<sub>2</sub>) emission for the potable water treatment and delivery in Blacksburg, based on fossil fuel-based electricity use per cubic meter of water delivered (0.40 kWh/m<sup>3</sup>), is estimated as follows:

$$\begin{aligned}
 & 11.4 \times 10^6 \text{ m}^3/\text{day} \times 0.4 \text{ kWh/m}^3 \times 0.9603 \text{ kg (CO}_2\text{)/kWh} \\
 & = 4,379 \text{ kg CO}_2/\text{day} \text{ (} 1.6 \times 10^6 \text{ kg/year)}
 \end{aligned}$$

These data can be used to demonstrate the potential carbon emissions associated with water consumption in individual buildings. Table 4 shows the annual carbon footprint of water consumption that can be attributed to fossil fuel-based electricity for selected buildings in Blacksburg, Virginia. Water consumption in each building is estimated from water meter readings. Electricity use is based on 0.40 kWh/m<sup>3</sup> water consumption. Carbon dioxide output for each building is estimated in accordance to the conversion factor for coal-generated electricity (Table 2). Since hundreds or thousands of similar buildings can be contained within a typical urban area, these estimates suggest the magnitude of potential reductions in total water consumption and carbon emissions that can be realized through reductions in water consumption in individual buildings.



## 4 Mitigation Strategies

Mitigation strategies are practices that directly or indirectly reduce fossil fuel-based electricity use and, consequently, reduce carbon dioxide emissions. In general, these strategies include water conservation (indirect energy saving), energy-use efficiency and conservation (direct energy saving), decentralized water infrastructure (reduction of energy use for water delivery), and elimination or reduction of fossil fuel use through the integration of renewable energy in water treatment and delivery in urban areas. These mitigation strategies can be reinforced by implementing policy options and financial incentives that encourage water and energy conservation in urban environments and by conducting educational and outreach programs to increase public awareness of water and energy conservation.

### 4.1 *In-Building Water Conservation*

Water consumers in urban areas include commercial facilities, public facilities such as governmental buildings and schools, and dwellers of apartment buildings and private residences. For each of these consumers, there are opportunities for water conservation that could result in energy saving and mitigating carbon footprint of water consumption [9]. Two possible in-building water conservation approaches are citizen education about value of water and using water and energy-saving fixtures.

Citizen awareness about the availability and limitations of water and energy resources is an effective approach that should be promoted. For example, Parece et al. [10] discuss the concept of environmentally relevant behavior (ERB), its application, and the positive consequences from reducing the carbon footprint of water consumption in university residence halls. This study indicated that students created a new social norm of ERB, evidenced by the 77 % participation rate in conservation-related activities and the fact that 90 % of respondents pledged to continue their behavior beyond the study (as reported by the students in a follow-up survey). Study results were reported to university officials at the end of each study period. The study results provided useful information to university officials on how to evaluate the impact of an intervention strategy to increase ERB and reduce water and energy consumption, which will ultimately result in university cost savings and reduction of its carbon footprint.

A second approach for in-building water conservation is adapting water-saving fixtures such as low-volume showers and toilets and water-/energy-efficient washing machines, dishwashers, and water-heating devices. Technologies for these devices have vastly improved in recent years. In addition to upgrades and replacements to water fixtures, water consumption can also be reduced through modification of landscaping, alterations to swimming pools and exterior water features,

**Table 5** Examples of water and energy reductions attributed to water-saving fixtures and other practices

Building type	Method	Water reduction (m <sup>3</sup> /year)	Energy reduction (kWh)	Reference citation
Hilton Palacio Hotel, San Antonio, Texas (USA)	Replaced old fixtures with new WaterSense <sup>®</sup> fixtures/eliminated	98.4 × 10 <sup>3</sup>	480,000	[12]
	Water-cooled ice machines			
Holiday Inn Hotel, San Antonio, Texas (USA)	Installed high-efficiency fixtures/reused the condensate from heating and cooling equipment to irrigate landscape and rooftop herb garden/reused backwash water from swimming pool and blowdown water from cooling fan	26.5 × 10 <sup>3</sup>	330,000	[13]
Hyatt Regency Hotel, Atlanta, Georgia (USA)	Installed high-efficiency restroom fixtures/installed non-water urinals/optimizing chiller system/supplemental landscape irrigation	136 × 10 <sup>3</sup>	10.6 % reduction in energy use (kWh not reported)	[14]

reconfiguration of chiller systems, elimination of water-cooled ice machines, and changes to the frequency of linen and laundry services.

The US Environmental Protection Agency (US EPA) has developed guidelines for consumer water-saving strategies. These guidelines are available on the EPA's website [11]. Water conservation approaches are practiced in various types of buildings, but the practice is particularly prominent in the hotel industry (Table 5). As shown in Table 5, two hotels, the Holiday Inn (San Antonio) and the Hilton Palacio (San Antonio) reported annual energy savings of 330,000 and 480,000 kWh, respectively, while the Hyatt Regency (Atlanta) realized an annual energy savings of 10.6 % [12–14]. In addition, annual monetary savings in two of these hotels due to energy conservation were \$80,000 (USD) (Hilton Palacio) and \$33,000 (USD) (Holiday Inn). Monetary savings due to energy conservation in hotels and other commercial and governmental buildings provide a great incentive for converting to water-saving in-building fixtures and other water-saving practices.

## 4.2 Water Utility Energy-Use Efficiency

The Water Research Foundation (WRF) has published a comprehensive report and guidelines on water utility energy-use efficiency [15]. The WRF report (page 19) states “one way for a water utility to identify areas or opportunities to reduce energy use without negatively affecting the system processes or water quality is through an energy audit. The goal of any energy audit is for management to assess the energy

use or energy flows of the water system and to identify the most energy-intensive areas of the system, outline possible actions and energy conservation measures, and set a plan of action in motion.”

Urban water and wastewater infrastructure includes both drinking-water and wastewater treatment facilities. Drinking-water utilities consist of water source development, water treatment plants, and drinking-water distribution networks. While potable water distribution networks are energy intensive because of the necessity for pressurizing the system, wastewater drainage networks are mostly designed to flow by gravity, with wastewater treatment plants primarily installed at lower elevations near water bodies where the treated wastewater is discharged. Only occasionally are pumps used to collect and discharge wastewater. Therefore, energy demand in wastewater treatment facilities is mostly attributed to the wastewater treatment process itself.

Significant potential exists for reducing energy consumption at water and wastewater treatment plants by implementing sustainable management practices. The US EPA has introduced tools and guidance for energy efficiency at water and wastewater treatment plants. These tools and guidance are available on the US EPA website [16]. Improving energy efficiency in water and wastewater utilities includes both reducing power demand and energy use. From an energy-use perspective, three major components of urban water infrastructure described below are: (1) water source development for potable water supplies, (2) water and wastewater treatment facilities, and (3) potable water distribution networks.

#### 4.2.1 Water Source Development

Conventional sources for potable water supplies are freshwater sources that include groundwater and surface water (rivers and lakes). Alternative water sources include saltwater, brackish water, rainwater, and reclaimed wastewater. Discussion in this section is limited to freshwater sources.

Pumps use energy to lift up water from a groundwater aquifer or to transport water via pipelines from a surface water source to a water treatment facility. In general, groundwater source development requires more energy than surface water systems largely because of the vertical lift required to extract water from the underground aquifer [17]. Energy-use efficiency for groundwater development is a factor of pump efficiency and groundwater depth. Pumps are also often used to lift up water from a surface water source to a water treatment plant. Therefore, pump selection is a critical criterion for water source development. Rothausen and Conway [18] estimated that at 100 % efficiency, for each 1-m lift, a pump uses 0.0027 kWh of energy to extract 1 m<sup>3</sup> of water. However, Plappally and Lienhard [19] reported that 0.004 kWh energy is needed to extract 1 m<sup>3</sup> of water per 1 m of lift, an almost 50 % higher energy use than the energy demand estimated by Rothausen and Conway [18]. This gap between the minimum feasible energy and the amount of real energy demand represents an opportunity for energy conservation.

Several case studies related to pumping efficiency were documented in the Water Research Foundation report [15]. For example, it was reported that the

Austin Texas (USA) water utility saved 5000 MWh annually by minimizing pump throttling. Throttling is carried out by opening and closing a discharge valve. Throttling is energy inefficient since energy is wasted by increasing the dynamic loss. Throttling can be minimized by adapting pump capacity to process water demand. In another case study, the Metro Vancouver/Greater Vancouver Water District (British Columbia, Canada) reduced its energy use by making improvements at its Cape Horn station, a fixed-speed pumping station constructed in the 1970s. These improvements included implementing a lower motor speed during off-peak times. By using the lower motor speed, annual energy usage fell from 90,000 to 65,000 kWh, saving 25,000 kWh of energy. At the Mohawk Valley Water Authority (MVWA), New York (USA), installing a hydro-turbine/generator at its Deerfield site and coupling the turbine/generator directly to the recirculation pump enabled the MVWA to provide electricity for continuous pump operation with an annual energy savings of 1,014,628 kWh [15].

While for groundwater source development, water table depth below the ground surface is a critical factor for pump energy use, for surface water development, energy-use efficiency is also a factor of topography and water transport distance via pipeline [20]. For example, in the USA, New York City and Los Angeles represent extremes of the energy required for source water transportation. In the case of New York City, source water from upper New York state is mostly transported by gravity flow to New York City. In contrast, in Los Angeles, source water is transported via the California Aqueduct, a system of canals, tunnels, pipelines, and pumps that transports source water from the Sierra Nevada mountains and valleys of Northern and Central California to Southern California and uses 2.09–2.62 kWh of energy per cubic meter of water transported [21].

#### 4.2.2 Drinking-Water Utility: Energy Conservation

In its comprehensive report, the Water Research Foundation [15] concluded that all drinking-water utilities, regardless of size, can take steps to reduce both energy consumption and costs between 10 % and 30 %. The WRF report noted that these savings can be realized through a range of actions including: (1) utilizing new, energy-efficient technologies, (2) incorporating energy-efficient practices into daily operations, (3) taking advantage of incentives and rebates from energy providers, (4) installing premium efficiency motors and variable speed drives, (5) resizing pumping systems, (6) developing alternative pumping schemes and pump system upgrades, (7) installing controls and monitoring systems, (8) optimizing operations, (9) implementing building upgrades (e.g., lighting and heating and cooling), (10) benchmarking and energy audits, (11) shifting power consumption from on-peak to off-peak hours, (12) adding or more effectively using storage, (13) promoting water conservation and use of energy-efficient products, (14) reducing system leaks, (15) evaluating system life cycle energy costs associated with proposed projects, and (16) evaluating the use of alternative energy sources [15].

## Drinking-Water Treatment

Highly impure source (raw) water, such as wastewater, saltwater, and contaminated freshwater, requires more energy for treatment compared to less contaminated freshwater sources. For example, desalination of brackish and seawater for potable consumption requires significantly more energy than treating a freshwater source [22]. Advanced water treatment technologies, such as reverse osmosis (RO) which requires pressure, are more energy intensive, as compared to traditional sand filtration. For example, advanced water treatment technologies (ozone or microfiltration/ultrafiltration) can increase annual energy use for a 10-MGD ( $3.8 \times 10^4 \text{ m}^3/\text{day}$ ) water treatment plant by over 1 million kWh/year relative to conventional water treatment [23]. Research and development of new membrane technologies and other innovative water treatment systems aim not only to remove a wide range of contaminants from all types of water but also to reduce the energy consumption for water treatment with less cost.

For example, cogeneration plants are becoming a common practice. Cogeneration plants combine power generation plants with desalination plants in order to reduce energy consumption [22]. The typical power plant produces steam at high pressure and high temperature. The steam expands, and pressure differences from the expansion drive the turbine to form mechanical energy, which is then converted to electrical energy (combustion turbine power generation cycle). The expanded steam is typically rejected from the power plant as waste, but a cogeneration plant uses this low-grade steam for desalination.

Colocated plants provide another example of the potential for energy conservation [22]. In colocated plants, a seawater reverse osmosis (SWRO) plant is colocated with a power plant. In general, coastal power plants draw large volumes of cooling water directly from the ocean. A colocated SWRO plant draws heated seawater from the power plant's cooling water loop as feedwater for RO and then discharges the concentrated stream into the power plant's cooling water outflow. Because the SWRO facility "piggybacks" on the existing cooling water loop, it can substantially reduce construction and operating costs. It also provides a method for diluting the SWRO brine stream before it is discharged into the ocean. A colocated SWRO plant has the advantages of a cogeneration plant. Furthermore, because of the higher water temperature at colocated plants, less energy is needed for water treatment. The disadvantage of the colocated plant is that it entirely depends on the power plant for its existence.

## Water Distribution Network

As demonstrated in the Blacksburg case study site [8], drinking-water distribution consumes significant amounts of energy compared to the water treatment process. Approximately 80 % of a water sector's energy use is associated with the processing and distribution of drinking water [24]. Improvement in pump efficiency and system design can significantly reduce energy demand in water distribution systems. For example, it's estimated that in the USA, improvements in pump and

motor system efficiency could save 2600–7800 million kWh of energy annually [25].

From an energy-saving perspective, energy wastage from leaking water distribution pipelines is another critical problem. Treated water loss during transportation from water treatment plants to consumer ranges from 10 % to 50 %, depending on pipeline age and maintenance [26]. In the USA, this water loss translates to about  $6.4 \times 10^9$  m<sup>3</sup>/year (1.7 trillion gal/year) [27], resulting in significant energy wastage. Large volumes of leakage can result in excessive energy loss and increases in the associated carbon footprint. As a mitigation strategy, water and associated energy losses can be reduced by timely and regular maintenance of water distribution pipes [28–31]. According to the Southern California Edison Leak Detection Pilot Program, energy savings from repairing drinking-water distribution system leaks was 178,000 kWh/year [32]. Recent advances in leak detection technologies facilitate early leak detection and prevent significant excessive water loss and energy wastage in water distribution systems [33, 34].

### 4.2.3 Wastewater Treatment Facilities

A US EPA report documented several case studies of wastewater treatment facilities that implemented energy-efficient strategies [35]. Selected case studies from the EPA report are illustrated in Table 6. Wastewater treatment facilities depicted in Table 6 implemented several energy efficiency measures with the goal of reducing the overall amount of energy required for wastewater treatment. Though each treatment plant is unique, given the volume/type of waste and its geographical location, the measures and techniques used to reduce use and costs are similar and often differentiated only by the number and type of blowers and controlling dissolved oxygen (DO) concentration. Optimal DO concentration is a critical parameter in biological wastewater treatment, and, as such, the mechanical blower used for aeration can be the key to saving energy in the second stage of biological treatment [35].

In wastewater treatment plants, a combination of installing variable-frequency drives and upgrading to energy-efficient motors, along with other upgrades to infrastructure, can result in significant savings in energy usage. A study conducted at the Encina Wastewater Authority (EWA), California (USA), evaluated the impact of equipment upgrades on energy savings [36]. Table 7 shows estimated annual energy savings attributed to internal upgrades at the Encina wastewater facility. It should be noted that these equipment upgrades are mostly applicable to drinking-water treatment plants.

Cogeneration of electricity and on-site thermal energy use from waste methane at the wastewater treatment plants provide another opportunity for energy saving. The generated thermal energy can be used to lower the overall electricity use in the facility. For example, at the EWA facility the generated heat is used to heat offices and run three absorption chillers that provide cooling [36]. It should be noted that energy savings in wastewater treatment plants have positive financial and economic ramifications. For example, at the Green Bay Metropolitan Sewerage District

**Table 6** Examples of energy conservation measures in wastewater treatment plants [35]

Wastewater treatment facility	Average daily flow (m <sup>3</sup> )	Energy conservation measures	Energy savings (kWh/year)
Green Bay Metropolitan Sewage District, DePere, Wisconsin (USA)	$3.28 \times 10^3$	Upgrades to aeration systems. Installed HST ABC magnetic-bearing turbo blowers	2,143,975 (50 % reduction in energy use)
Sheboygan Regional WWTP, Sheboygan, Michigan (USA)	$44.66 \times 10^3$	Upgrades to aeration systems. Replaced blowers with 2 Turblex blowers with upgraded DO control and SCADA. Installed air control valves on headers and upgraded PCL	459,000 (13 % reduction in energy use)
Oxnard, California (USA), Plant # 32	$84.78 \times 10^3$	DO optimization and control of SRT using proprietary process modeling based control algorithms	306,600 (20 % reduction in energy use)
Bucklin Point, Narragansett Bay Commission, Rhode Island (USA)	$89.70 \times 10^3$	DO optimization using floating pressure blower control and a most open valve strategy	1,243,035 (11.6 % reduction in energy use)
San Jose/Santa Clara, California (USA), Water Pollution Control Plant	$404.99 \times 10^3$	DAF solids thickening process optimization process using proprietary process and control algorithms	1,603,030 (64 % reduction in energy use)

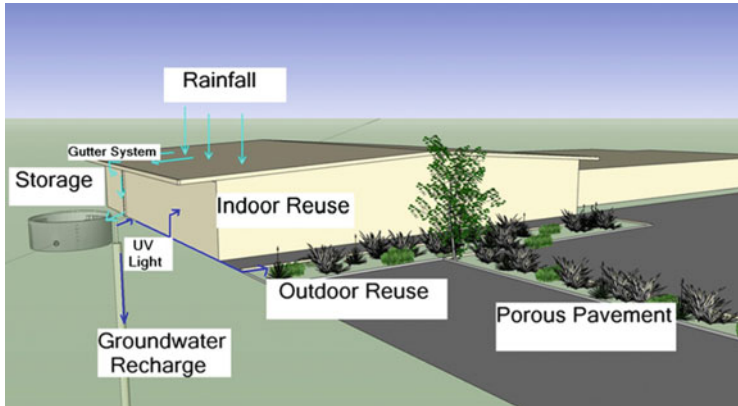
**Table 7** Energy savings in wastewater treatment attributed to equipment upgrades [36]

Equipment upgrades (Encina wastewater facility, California (USA))	Estimated energy savings (kWh/year)
Upgrade blower throttle control with variable frequency drives (VFD) control	1,544,503
Replace multistage centrifugal compressors with turbo blower technology	2,010,379
Retrofit plant water pumps with VFD controls	397,954
Retrofit solid digestion pumps with VFD controls	744,063

(Table 6), the 2,143,975 kWh/year of energy saving resulted in monetary saving of \$63,758/year (USD), while at the Sheboygan Regional Wastewater Treatment Plant (Table 6), the 459,000 kWh/year of energy saving, the annual monetary saving was \$38,245 (USD) [35].

### 4.3 Decentralized Water Infrastructure

Decentralized water infrastructure is defined as small-scale water systems that collect locally available water such as captured rainwater and graywater for various



**Fig. 1** Typical decentralized water infrastructure for potable water-saving and stormwater runoff control (Source: first author, credit: Caitlin Grady)

indoor and outdoor uses. Decentralized systems reduce water transport and pumping needs via conventional networks (Fig. 1). The system may incorporate advanced small-scale water treatment technologies depending on anticipated water use.

Decentralized water systems can also provide water to urban agricultural plots and green roofs and enhance local food production in urban areas. Two types of decentralized systems, “rainwater harvesting systems” and “small-scale water reuse and recycling systems,” are briefly described below. Technical details for these systems are provided in chapters “[Reclaimed Water Use and Energy Consumption: Case Study in Hotel Industry, Beijing](#)” and “[Modern Rainwater Harvesting Systems: Design, Case Studies, Impacts](#)” of this book.

### 4.3.1 Rainwater Capture and Use System

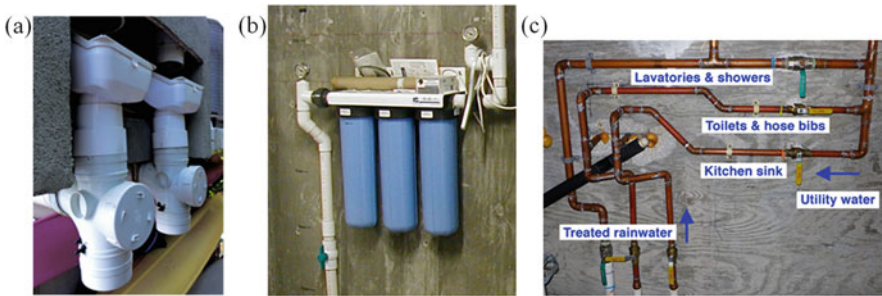
Small-scale rainwater harvesting has been performed around the world since ancient times. Small-scale rainwater capture and direct use, similar to system shown in Fig. 2, is still common in many parts of the world. Recent technological advances in pre-filtration, first-flush design, and small-scale water treatment units ensure that, with appropriate treatment, captured rainwater can be used as a drinking-water source [37]. Figure 3 shows components of a modern small-scale rainwater harvesting system.

Significant opportunities exist for rainwater capture and use in commercial and other buildings in urban areas. Rooftop areas constitute 30–40 % of impervious surfaces in urban settings. A 100 m<sup>2</sup> rooftop area can collect 10 m<sup>3</sup> of water per 1.0 cm of rainfall. In the absence of a rainwater harvesting system, rainwater falling on urban rooftops is usually wasted via runoff drainage. Instead, after extracting potential losses (evaporation, splash, etc.), about 75–80 % of this captured rainwater can be made available for various indoor and outdoor uses. Indoor non-potable





**Fig. 2** Traditional rainwater capture and use in a mountaintop house, Southwest Virginia, USA (Source: first author)



**Fig. 3** Components of a modern household dual rainwater and utility water use system in Key Largo, Florida, USA. (a) Pre-filtration unit. (b) Water treatment unit. (c) Dual rainwater/utility water use (Source: first author [37])

uses of captured rainwater include toilet flushing, laundry, and cooling (air conditioning). Outdoor uses include landscape irrigation, fountains, and car wash. Furthermore, captured rainwater can be integrated in the design of green roofs and urban agriculture systems (see chapters “Sustainable Water Management in Green Roofs” and “Irrigating Urban Agriculture with Harvested Rainwater: Case Study in Roanoke, Virginia, USA” of this book).

From an energy conservation perspective, rainwater capture can reduce dependence on energy-intensive potable water. Table 8 illustrates an example of energy saving attributed to potable water savings and estimated CO<sub>2</sub> reduction attributed to rainwater harvesting systems.

Few data are available for direct comparison of energy use by a centralized water supply system and a decentralized rainwater harvesting system. However, Ward et al. [39] reported that rainwater harvesting systems are more energy efficient than

**Table 8** Potable water and energy savings attributed to rainwater harvesting [38]

Building location <sup>a</sup>	Type of harvested rainwater use	Potable water saving (m <sup>3</sup> /year)	Estimated energy savings (KWh) <sup>b</sup>	Estimated CO <sub>2</sub> reduction (kg/year) <sup>b</sup>
Oscar Smith Middle School, Chesapeake City, Virginia (USA)	Landscape irrigation and toilet flushing	14,118	5409	5193
Western Virginia Regional Correction Facility, Roanoke County, Virginia (USA)	Laundry facilities	17,411	6670	6387

<sup>a</sup>Rainwater Management Solutions, Inc. <http://www.rainwatermanagement.com/>

<sup>b</sup>Calculated using values given in Table 2 [5]

using municipal water. Younos and Lawson [38] illustrated a comparative example for a study site (Anacostia Senior High School, Washington DC, USA). Based on an average annual rainfall of 100 cm for Washington DC and assuming a 30 % loss from the system, the rooftop of this school building (about 7711 m<sup>2</sup>) has the potential to generate as much as  $5.0 \times 10^3$  m<sup>3</sup>/year of water that can be used for non-potable uses, i.e., flushing toilets/urinals and landscape irrigation. The captured rainwater can substitute for an equivalent volume of potable water from the public water supply system. Based on estimates from electricity use data, obtaining this  $5.0 \times 10^3$  m<sup>3</sup>/year from a municipal source would require 3145 kWh of electricity per year. Instead the rainwater harvesting system would require just 776 kWh/year for the same volume of water, resulting in a potential energy savings of 2370 kWh/year. In a recent study, Hammerstrom and Younos [37] estimated the pumping requirement for distributing captured rainwater to a residential home as 0.26 kWh/m<sup>3</sup> of water. For further discussion the reader is referred to [20] and chapter “[Modern Rainwater Harvesting Systems: Design, Case Studies, Impacts](#)” of this book.

### 4.3.2 Small-Scale Water Reuse and Recycling

Incorporating small-scale advanced packaged water treatment technologies as a decentralized water treatment system will eliminate or minimize construction of energy-intensive water distribution networks. Advances in small-scale and packaged water treatment technologies (e.g., RO plus UV disinfection devices) allow installing small-scale decentralized water production systems as satellite systems in individual buildings in and around urban areas. A typical small-scale packaged water treatment system with a capacity of up to 50,000 l/day can be configured as a water treatment unit that is just 1.2 m long, 1.0 m wide, and 2.1 m high, easily fits into a small room, and can be operated with minimal training (Fig. 4).

Proper design of integrated small-scale water treatment systems using local water sources such as captured rainwater, wastewater (reuse and recycling), or



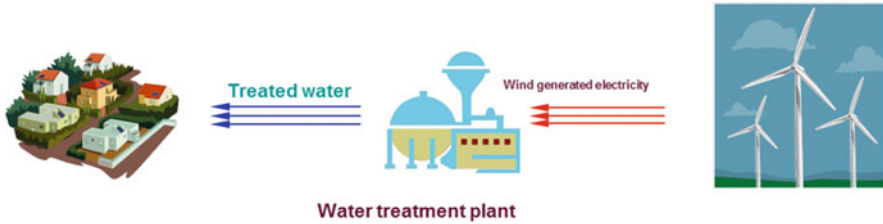
**Fig. 4** Typical advanced small-scale water treatment system (*Source: first author*)

saline water will alleviate the scarcity of potable water at a community level and minimize construction of water distribution networks. For example, chapter “[Reclaimed Water Use and Energy Consumption: Case Study in Hotel Industry, Beijing](#)” of this book discusses the wastewater treatment and recycling in hotel industry.

Bottled water production and distribution at the local level is an excellent case of using advanced packaged water treatment technologies to supply water and create jobs at the local level. Technically, bottled water can be categorized as a decentralized water supply system; it facilitates drinking-water distribution via bottles or containers to consumers instead of constructing a high-cost water distribution infrastructure. Normally, bottled water is energy intensive because of the energy used to transport bottled water from the production plant to the market [40]. However, local production and distribution of bottled water is less energy intensive. For example, packaged water treatment-bottling plants installed in several suburban Mexican communities use groundwater or other local water sources to produce safe drinking water for the local and nearby communities [40].

#### ***4.4 Integrating Renewable Energy Use and Water Infrastructure***

From an energy conservation and carbon footprint reduction perspective, the advantages of water and energy conservation noted above are limited because



**Fig. 5** Hypothetical integration of renewable energy source and water treatment plan (Source: first author, credit: Juneseok Lee)

increased global water demand will result in higher energy demand and, consequently, increased CO<sub>2</sub> emissions. To achieve the goal of reducing the carbon footprint attributed to water and energy consumption, reducing dependency of water infrastructure on fossil fuels should be a critical objective in water infrastructure planning and design. Integrating renewable energy use in water/wastewater treatment and distribution system design provides a significant opportunity to achieve a reduction in carbon footprint.

Renewable energy resources for water and wastewater treatment may include, but are not limited to, solar (photovoltaics, active or passive solar systems), wind, geothermal, bioenergy, and micro-hydro power. Figure 5 shows a hypothetical example of integrating renewable energy in water treatment system.

Research development in the arena of cost-effective renewable energy use in water infrastructure is an evolving field of science and technology. Solar energy can be used directly for simple distillation or indirectly through the use of collectors. Currently, the most promising solar energy technology is photovoltaic (PV) arrays. Photovoltaic arrays convert solar energy into electricity through the transfer of electrons. The arrays are made of silicon chips which are considered the best material for the transfer of electrons. When the sun's rays shine on the silicon chips, the electrons jump to another orbit. This movement creates a voltage that can be used to power pumps for desalination [41].

Wind energy rotates wind turbines and creates mechanical energy that can be converted to electrical energy. Wind turbines come in both vertical axis arrangements and multiple axis, horizontal arrangements. Turbines utilizing wind energy for low power ( $34\text{--}341 \times 10^3$  Btu/h or 10–100 kW), medium power ( $341\text{--}1707 \times 10^3$  Btu/h or 100 kW–0.5 MW), and high power ( $>1707 \times 10^3$  Btu/h or 0.5 MW) are mature technologies [41].

In the USA, some water utilities are already powered by renewable energy. For example, the Washington Suburban Sanitary Commission (WSSC) uses wind energy to power one-third of WSSC's water and wastewater operations (15). The wind power to WSSC is provided by 14 wind turbines that are installed on a farm in southwestern Pennsylvania, generating 70,000-MWh of power a year. The state of Massachusetts (USA) launched a pilot program to increase energy efficiency statewide for drinking and wastewater facilities. This program includes 21 water and wastewater facilities, 14 pilot sites, and seven identified green sites

**Table 9** Examples of estimated savings from renewable energy upgrades at drinking-water treatment facilities, Massachusetts, USA [42]

Water treatment facility	Renewable energy generation (kW)	Total annual energy saving (kW)	Estimated annual CO <sub>2</sub> reduction (kg)
Ashland Howe Street Water Treatment Plant	Solar (up to 45 kW)	194,464	233 × 10 <sup>3</sup>
Easton Water Division	Solar (up to 50 kW)	60,000	47 × 10 <sup>3</sup>
Falmouth Long Pond Water Treatment Plant	Solar (up to 15 kW)	278,200	216 × 10 <sup>3</sup>
Lee Water Treatment Plant	Solar and hydroelectric (up to 105 kW)	200,940	155 × 10 <sup>3</sup>
New Bedford – Quittacus Water Treatment Plant	Solar (up to 138 kW)	165,000	168 × 10 <sup>3</sup>
Townsend Water Treatment Plant	Solar (up to 40 kW)	73,844	57 × 10 <sup>3</sup>
Worcester Water Treatment Plant	Solar and hydroelectric (up to 160 kW)	553,152	430 × 10 <sup>3</sup>

**Table 10** Examples of estimated savings from renewable energy upgrades at wastewater treatment facilities, Massachusetts, USA [42]

Wastewater treatment facility	Renewable energy generation (kW)	Total annual energy saving (kW)	Estimated annual CO <sub>2</sub> reduction (kg)
Barnstable Wastewater Treatment Plant	Wind and solar (1000 kW)	850,000	825 × 10 <sup>3</sup>
Charles River Pollution Control District	Solar (20 kW)	705,300	567 × 10 <sup>3</sup>
Falmouth Wastewater Treatment Plant	Wind (3150 kW)	4,235,000	3181 × 10 <sup>3</sup>
Great Lawrence Sanitary District	Solar (410 kW)	4,909,062	5420 × 10 <sup>3</sup>
Pittsfield Wastewater Treatment Plant	Solar and biomass (1770 kW)	4,255,737	3252
Upper Blackstone Water Pollution District	Solar (400 kW)	831,615	636

[42]. Tables 9 and 10 show the estimated annual energy savings and CO<sub>2</sub> emission reductions attributed to renewable energy for selected water and wastewater treatment plants for the State of Massachusetts pilot program.

At present, solar energy provides the best opportunity for integrating renewable energy into large-scale water supply systems and other applications such as wastewater treatment and desalination for potable purposes. An excellent example in the USA is the New Jersey American Water Canal Road Water Treatment Plant which was installed in 2005 (Fig. 6). The system includes two 225 kW alternating current (AC) inverters, revenue-grade metering, and an internet-based data acquisition system. The original solar array consisted of 2871 solar PV modules, each rated



**Fig. 6** Photovoltaic system at NJAW Canal Road WTP (*Source: New Jersey American Water*) (with permission from NJAW – August 31, 2015)

at 175 W for a total DC output of 502 kW. In 2007, the system was expanded by 87 kW (a 17 % increase) for an overall output of 590 kW. A third expansion of 109 kW DC was constructed on top of the filter basins in 2008 to increase the overall capacity of the site to 698 kW DC. The solar array currently supplements approximately 20 % of the Canal Road WTP's peak usage [15].

Significant demand exists for desalination of seawater and brackish water around the world to meet the large and increasing water demand in high-population coastal cities and resort towns in island countries [43]. Desalination technologies are energy intensive and provide an opportunity for integrating renewable energy for producing freshwater around the world. Younos and Tulou [21] published a review of energy conservation and using renewable energy in desalination facilities. Tables 11, 12, and 13 show examples of desalination facilities powered by solar and wind energy around the world [21, 41, 44].

There are limited cases of renewable energy used for water source development reported in the literature. Al-Smairan [45] described a case study that used photovoltaic solar energy to power a remote area groundwater pumping station in Jordan in comparison with diesel pumps. This study concluded that photovoltaic water pumping systems could be more cost-effective than diesel engines in energizing pumping systems at the case study site. Further development of PV technologies will have significant potential to reduce the energy and carbon costs associated with groundwater and other source water development and water distribution in urban areas.

**Table 11** Desalination plants incorporating solar energy [21, 41]

Location	Type of solar energy	Desalination technology	Capacity (m <sup>3</sup> /d)
El Paso, Texas, USA	Solar pond	MSF	16.19
Yanbu, Saudi Arabia	Dish collectors	FS	199.96
La Desired Island, French Caribbean	Solar-evacuated tube	MED	40.01
Abu Dhabi, UAE	Solar-evacuated tube	MED	119.98
Takami Island, Japan	Solar-parabolic trough	MED	15.99
Almeria, Spain	Solar-parabolic trough	MED-heat pump	71.99
Margarita de Savoya, Italy	Solar pond	MSF	49.99–59.99
Near Dead Sea	Solar pond	MED	2999.61

*FS* freeze separation, *MED* multiple effect distillation, *MSF* multiple stage flash distillation

**Table 12** Examples of desalination plants incorporating photovoltaic energy [21, 41]

Location	Power generated 10 <sup>3</sup> Btu/h (kW)	Desalination technology	Capacity (m <sup>3</sup> /day)
Perth, Western Australia	4.1 (1.2)	RO – seawater	2.40–12.10
Cituis West, Java, Indonesia	85 (25)	RO – brackish water	35.99
Lipari Island, Italy	215 (63)	RO – seawater	47.99
University of Almeria, Spain	80 (23.5)	RO – brackish water	59.99
Fukue City, Nagasaki, Japan	222 (65)	ED – brackish water	199.89

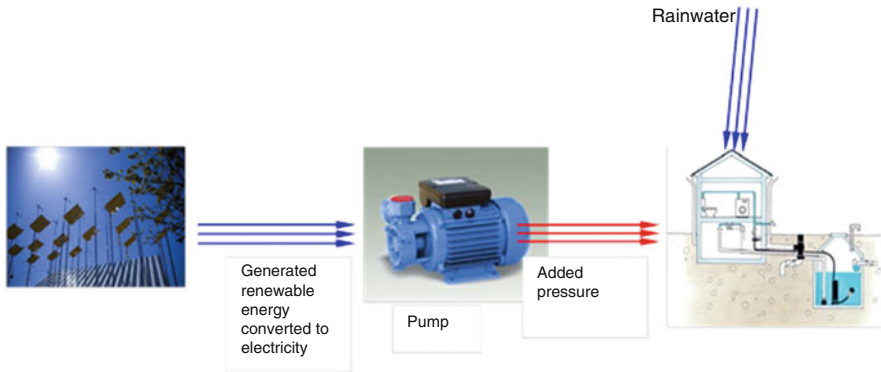
*RO* reverse osmosis, *ED* electrodialysis

**Table 13** Examples of desalination plants incorporating wind energy [21, 40]

Location	Power generated 10 <sup>3</sup> Btu/h (kW)	Desalination technology	Capacity (m <sup>3</sup> /day)
Shark Bay, Western Australia	109 (32)	RO – brackish water	129.98–167.98
Ruegen Island, Germany	683 (200)	MVC	119.98–299.96

*RO* reverse osmosis, *MVC* mechanical vapor compression

The integration of decentralized solar and other renewable energy technologies and decentralized water infrastructure can provide a significant opportunity for energy conservation and reducing carbon footprint of water consumption. Potential applications include water source development and water delivery in decentralized water infrastructures, such as in-building (hotels, shopping centers, and other commercial buildings) captured rainwater and graywater reuse, and outdoor uses



**Fig. 7** The vision for integrated water and energy use in decentralized green water infrastructure (Source: first author)

such as fountains and landscape irrigation. Figure 7 shows a hypothetical example of integrating decentralized water and energy infrastructures in urban and suburban environments.

## 5 Conclusions

This chapter provides an overview of the water and energy nexus in urban areas and estimates of energy consumption in urban water infrastructure and the carbon footprint associated with water consumption. Mitigation strategies for reducing the carbon footprint of water consumption discussed in this chapter include in-building water conservation measures, energy-use efficiency in urban water infrastructure, and the potential of decentralized water infrastructure in reducing energy consumption. Finally, the chapter discusses the potential for integrating renewable energy resources in urban water infrastructure in order to reduce dependency of urban water infrastructure on fossil fuel-based energy, thus reducing the carbon footprint of water consumption.

As the contents of the chapter indicate, significant opportunities exist for both energy conservation and for reducing the carbon footprint of water consumption in urban environments. Concepts and case studies described in this paper can be used as a guide for providing safe and energy-efficient water to global communities.

In the future, the integration of decentralized solar and other renewable energy technologies and decentralized water infrastructure can provide a significant opportunity for energy conservation and reducing the carbon footprint of water consumption. Potential applications include water source development and water delivery in decentralized water infrastructures such as in-building (hotels, shopping centers, and other commercial buildings) using captured rainwater and graywater reuse.



Also, decentralized and integrated renewable energy (e.g., solar and wind) and seawater desalination can provide significant energy savings in coastal urban areas.

Yet, despite the clear potential for reductions in both energy consumption and CO<sub>2</sub> emissions, additional policy and financial incentives are needed to ensure that these mitigation strategies become more widely adopted in the future development of water infrastructure around the world.

## References

1. United States Census Bureau (2012) Growth in urban population outpaces rest of nation, Census Bureau reports. [https://www.census.gov/newsroom/releases/archives/2010\\_census/cb12-50.html](https://www.census.gov/newsroom/releases/archives/2010_census/cb12-50.html). Accessed 31 Aug 2015
2. World Health Organization (WHO) (2014) Urban population growth, Global Health Observatory (GHO) data. [http://www.who.int/gho/urban\\_health/situation\\_trends/urban\\_population\\_growth\\_text/en/](http://www.who.int/gho/urban_health/situation_trends/urban_population_growth_text/en/). Accessed 31 Aug 2015
3. CRS (2013) Energy-water nexus: the water sector's energy use. Congressional Research Service (CRS) 7-5700, CRS, Washington, DC
4. AWWARF (2007) Energy index development for benchmarking water and wastewater utilities. American Water Works Association Research Foundation, Denver
5. Kloss C (2008) Managing wet weather with green infrastructure municipal handbook: rain-water harvesting policies. U.S. Environmental Protection Agency, Washington, DC, EPA-833-F-08-010
6. Stokes JH, Horvath A (2005) Life cycle energy assessment of alternative water supply systems. *Int J Life Cycle Assess* 11(5):335–343
7. Lawson SE, Zhang Q, Joshi M, Tzu-Han P (2014) The effects of water-energy nexus on potable water supplies. In: Younos T, Grady CA (eds) Potable water: emerging global problems and solutions, vol 30, The handbook of environmental chemistry. Springer, Heidelberg, pp 125–151
8. Younos T, Grady C, Chen T, Parece T (2009) Conventional and decentralized water infrastructure: energy consumption and carbon footprint. Extended Abstract In: Toniolo H (ed) Proceedings of the American Water Resources Association – 2009 spring specialty conference – managing water resources and development in a changing climate, Anchorage, 4–6 May
9. Younos T, Parece TE (2012) Water use and conservation. In: Stoltman J (ed) 21st century geography: a reference handbook. Sage, Los Angeles, pp 446–456
10. Parece TE, Grossman L, Geller ES (2013) Reducing carbon footprint of water consumption: a case study of water conservation at a university campus. In: Younos T, Grady CA (eds) Climate change and water resources, vol 25, The handbook of environmental chemistry. Springer, Heidelberg, pp 199–218
11. USEPA (2014) WaterSense: an EPA partnership program. <http://www.epa.gov/watersense/>. Accessed 31 Aug 2015
12. USEPA (2014) WaterSense: an EPA partnership program., Texas Hotel Upgrades to Four-Star Water Efficiency. [http://www.epa.gov/watersense/docs/ci\\_casestudy\\_hiltonpalacio\\_508.pdf](http://www.epa.gov/watersense/docs/ci_casestudy_hiltonpalacio_508.pdf). Accessed 31 Aug 2015
13. USEPA (2014) WaterSense: an EPA partnership program. Hotel Installs Water-Efficient Sanitary Fixtures. [http://www.epa.gov/watersense/docs/ci\\_casestudy\\_holidayinnsanantonioairport\\_508.pdf](http://www.epa.gov/watersense/docs/ci_casestudy_holidayinnsanantonioairport_508.pdf). Accessed 31 Aug 2015

14. USEPA (2014) WaterSense: an epa partnership. Georgia Hotel saves \$1M annually by maximizing mechanical system. [http://www.epa.gov/watersense/docs/ci\\_casestudy\\_hyattregencyatlanta\\_508.pdf](http://www.epa.gov/watersense/docs/ci_casestudy_hyattregencyatlanta_508.pdf). Accessed 31 Aug 2015
15. Leiby VM, Burke ME (2011) Energy efficiency best practices for North American drinking water utilities. Water Research Foundation, Denver, p 211. Available on the website <http://www.waterrf.org/Pages/Projects.aspx?PID=4223>. Accessed 31 Aug 2015
16. USEPA (2013) Determining energy use. [http://water.epa.gov/infrastructure/sustain/energy\\_use.cfm](http://water.epa.gov/infrastructure/sustain/energy_use.cfm). Accessed 31 Aug 2015
17. Mo W, Zhang Q, Mihelcic JR, Hokanson DR (2011) Embodied energy comparison of surface water and groundwater supply options. *Water Res* 45:5577–5586
18. Rothausen SG, Conway D (2011) Greenhouse-gas emissions from energy use in the water sector. *Nat Clim Chang* 1:210–219. doi:10.1038/NCLIMATE1147
19. Plappally AK, Lienhard JH (2012) Energy requirements for water production, treatment, end use, reclamation, and disposal. *Renew Sust Energ Rev* 16:4818–4848. doi:10.1016/j.rser.2012.05.022
20. Vince FE, Aoustin P, Breant P (2008) LCA tool for the environmental evaluation of potable water production. *Desalination* 220:37–56
21. Lawson SE (2013) Mitigating climate change in urban environments: management of urban water supply. In: Younos T, Grady CA (eds) *Climate change and water resources*, vol 25, The handbook of environmental chemistry. Springer, Heidelberg, pp 145–168
22. Younos T, Tulou K (2005) Energy needs, consumption and sources. In: *Desalination – a primer*. *J Contemp Water Res Educ* 132:27–38
23. Raucher RS, Cromwell JE III, Cooney K (2008) Risk and benefits of energy management for drinking water utilities. AWWA Research Foundation, Denver
24. EPRI (2002) Water and sustainability (volume 4): U.S. electricity consumption for water supply and treatment – the next half century. Technical report 1006787, Electric Power Research Institute, Palo Alto
25. Arzbaecher C, Carns K (2009) Program on technology innovation: electric efficiency through water supply technologies – a roadmap. Electrical Power Research Institute (EPRI), Palo Alto
26. Puusta R, Kapelanb Z, Savicb DA, Koppel T (2010) A review of methods for leakage management in pipe networks. *Urban Water J* 7(1):25–45
27. AWWA (2005) Sizing water services lines and meters (M22). American Water Works Association, Denver
28. Wykes AR (2007) Zero on in leaks to minimize water loss. American Water Works Association, Oplow, Denver, pp 15–17
29. Kunkel G, Sturm R (2011) Piloting proactive, advanced leakage management technologies. *J AWWA* 103(2):61–75
30. Venkatesh G (2012) Cost-benefit analysis – leakage reduction by rehabilitating old water pipelines: case study of Oslo (Norway). *Urban Water J* 9(4):277–286
31. Filion YR, MacLean HL, Karney BW (2004) Life-cycle energy analysis of a water distribution system. *J Infrastruct Syst* 10:120–130
32. Alliance for Water Efficiency (2013) Partnering for water & energy savings. Webinar, November 2013. <http://www.allianceforwaterefficiency.org/webinars.aspx>. Accessed 7 Sept 2015
33. Colombo AF, Lee P, Karney BW (2009) A selective literature review of transient-based leak detection methods. *J Hydro Environ Res* 2:212–227
34. Yang JA, Wen Y, Li P, Wang X (2012) Study on an improved acoustic leak detection method for water distribution systems. *Urban Water J* 10(2):71–84
35. U.S. EPA (2010) Evaluation of energy conservation measures for wastewater treatment facilities. EPA, EPA 832-R-10-005. <http://water.epa.gov/scitech/wastetech/upload/Evaluation-of-Energy-Conservation-Measures-for-Wastewater-Treatment-Facilities.pdf>. Accessed 31 Aug 2015

36. California Energy Commission (2011) Energy & emissions strategic plan final report, Encina Wastewater Authority. Kennedy/Jenks Consultants, 7 Apr 2011, K/J project no 0987118\*00. <http://www.encinajpa.com/Portals/0/DOCUMENTS/Energy%20Strategic%20Plan/energysp2011b.pdf>. Accessed 31 Aug 2015
37. Hammerstrom J, Younos T (2014) Single-family home rainwater-harvesting system demonstration project for stormwater-runoff control and utility-water saving. The Cabell Brand Center special report no 100-2014. [www.cabellbrandcenter.org](http://www.cabellbrandcenter.org). Accessed 31 Aug 2015
38. Younos T, Lawson S (2011) Climate change mitigation at the local level: decentralized water infrastructure – opportunities and challenges. Paper presented at the AWRA Spring Specialty Conference, Baltimore, 18–21 Apr 2011
39. Ward S, Butler D, Memon FA (2012) Benchmarking energy consumption and CO<sub>2</sub> emissions from rainwater harvesting systems: an improved method by proxy. *Water Environ J* 26 (2):184–190
40. Younos T (2014) Bottled water: global impacts and potential. In: Younos T, Grady CA (eds) Potable water – emerging global problems and solutions, vol 30, The handbook of environmental chemistry. Springer, Heidelberg, pp 213–227
41. Garcia-Rodriguez L (2002) Seawater desalination driven by renewable energies: a review. *Desalination* 143:103–113
42. USEPA (2009) Massachusetts energy management pilot program for drinking water and wastewater case study. U.S. Environmental Protection Agency, Washington, DC, EPA-832-F-09-014
43. Younos T, Tulou KE (2005) Overview of desalination techniques. In: *Desalination – a primer*. *J Contemp Water Res Educ* 132:3–10
44. Abou-Rayan M, Djebedjian B (2014) Advances in desalination technologies: solar desalination. In: Younos T, Grady CA (eds) Potable water: emerging global problems and solutions, vol 30, The handbook of environmental chemistry. Springer, Heidelberg, pp 181–211
45. Al-Smairan M (2012) Application of photovoltaic array for pumping water as an alternative to diesel engines in Jordan Badia, Tall Hassan Station: case study. *Renew Sust Energ Rev* 16:4500–4507

# Reclaimed Water Use and Energy Consumption: Case Study in Hotel Industry, Beijing

Yuan-sheng Chen, Long-teng Zhu, Jian-ming Che, Rui-rui Hao, Tian Shen, and Qian Zhang

## Contents

1	Introduction .....	58
2	Reclaimed Water Concept and Definition .....	59
3	Reclaimed Water Use in Beijing .....	60
4	Research Methods .....	61
4.1	Field Survey for Hotel Selection .....	61
4.2	Analysis of Hotel Reclaimed Water Reuse System .....	62
4.3	Analysis of Hotel Energy Use for Reclaimed Water System .....	66
5	Results and Discussion .....	67
5.1	Water Balance Analysis .....	68
5.2	Energy Use Analysis .....	72
6	Conclusions .....	76
	Appendix A: Questionnaire – Hotel Reclaimed Water Facilities in Beijing .....	78
	Appendix B: Questionnaire – Hotel Reclaimed Water Facilities' Water Consumption and Water Treatment in Beijing .....	79
	References .....	80

**Abstract** Analyzing the relationship between water balance and energy consumption for buildings' reclaimed water systems is useful in sustainable management of urban water. This chapter discusses the water balance and energy consumption relationship for reclaimed water systems, constructing a safety index for the hotel

---

Y.-s. Chen (✉) • Q. Zhang

Institute of Geographical Sciences and Natural Resources Research, CAS, Beijing 100101, China

e-mail: [chenyuansheng@igsrr.ac.cn](mailto:chenyuansheng@igsrr.ac.cn)

L.-t. Zhu

Department of Planning and Design, Huaihe Basin Water Resources Bureau of Shandong Province, Jinan 250100, China

J.-m. Che • R.-r. Hao

Beijing Water Conservation and Management Centre, Beijing 100036, China

T. Shen

Nanjing Water Supply and Saving Management Division, Nanjing 210004, China

industry in Beijing. This chapter also analyzes the energy consumption intensity, the corresponding quantitative relationship with water quantity and the major points of energy consumption, providing a reference model for research and analysis of the water balance energy consumption relationship for other reclaimed water systems. Based on our investigation: (1) The average energy consumption intensity of hotels' reclaimed water systems is  $1.02 \text{ kWh/m}^3$ , which is 2.5 times higher than urban wastewater treatment plant; (2) air blowers and recycle pumps are major energy consumers in hotel reclaimed water systems; (3) we introduce an energy consumption intensity power function for hotel reclaimed water system design; (4) we developed a safety coefficient  $\beta$ , which reflects the degree of safety, stability, and high efficiency of the system; and (5) we make recommendations for improving reclaimed water use system efficiencies.

**Keywords** Energy consumption • Hotel industry • Reclaimed water • Safety coefficient  $\beta$  • Water balance • Water recycling

## 1 Introduction

Reclaimed water use provides a secondary water source for a city, saving freshwater, reducing sewage discharge, relieving the pressure on municipal water supply and drainage network, and improving the ecological environment. However, many problems exist in the implementation and operation process of reclaimed water use. For example, in Beijing, China, a survey shows that 33 % of reclaimed water use projects are not operated efficiently [1]. Besides policies and regulations, design-related problems lead to high operating costs and substandard effluent quality. These problems also exist in decentralized reclaimed water treatment and use systems and operation processes described in this chapter. In a reclaimed water use system, water balance relationship is the basis for reclaimed water system design and the key factor for deciding the system size. Its quantitative analysis and calculation methods need to be further improved and enhanced.

In terms of energy consumption, wastewater treatment is an energy-intensive system [2]. Because of the high energy consumption and high operating cost, construction and operation of wastewater treatment plants are facing many challenges – difficult to construct and yet harder to operate. Under the current situation of electricity supply difficulties and inadequate energy supply, seeking an energy optimization strategy and reducing energy consumption are key factors for sustainable development of wastewater treatment systems.

Energy consumption problems of decentralized reclaimed water systems are equivalent to operation of a small-scale wastewater treatment plant. There is a need to further explore the relationship between energy consumption and system design and scale. In view of these problems, this chapter reports on the results of

field research and surveys of decentralized reclaimed water use in the Beijing hotel industry. The study includes an in-depth analysis of reclaimed water characteristics, water quantity balance and energy consumption, and analysis of energy consumption characteristics and energy efficiency for the design of reclaimed water systems' operation. This chapter provides technical support and guidance for design of reclaimed water systems' optimal operation and reclaimed water systems' operation security and stability.

## 2 Reclaimed Water Concept and Definition

The concept of reclaimed water, “Chusuido” or middle water, originated in the 1960s in Japan, i.e., “Chusuido,” as compared (from water quality perspective) to “Josuido” or drinking water and “Gesuido” or sewage. Reclaimed water is gray water drainage from urban buildings and residential areas, which is reused after properly treated to a certain water quality standard for a specific use. Reclaimed water is used for many purposes: landscape irrigation and garden greening (parks, schools, highway greenbelts, golf courses, cemeteries, residential, etc.), industry (cooling water, boiler water, process water), environmental enhancement (improvement of lakes, ponds, wetlands, increasing river flows and fish farming, etc.), fire protection, and indoor uses (air conditioning, toilet flushing, and other non-potable water uses). In a sense, reclaimed water is a form of renewable water, which is a major component of “recycled water.” “Recycled water” also includes water which meets drinking water standards after advanced treatment.

There are various interpretations and classifications of reclaimed water. Geographically, reclaimed water can be divided into city reclaimed water, region reclaimed water, residential reclaimed water, and building reclaimed water. The latter two, collectively, referred to as building water. Water reuse can occur via two categories – open recycling use and closed recycling use. Open recycling use can occur upstream and downstream within a city's water supply and drainage network, where the effluent from a drainage network is treated to meet water quality standards and then discharged upstream into a water body. The discharged water is further purified through natural processes before it becomes source water for downstream consumers. In a closed recycling system, the wastewater is treated to meet water quality standards and directly reused by consumers. Closed reclaimed water belongs to the closed recycling use category [3].

Reclaimed water for buildings is a water supply system which consists of drainage from civil construction areas or production activities and returned to buildings and consumers as gray water, through collection, processing, distribution, and other measures.

In-building reclaimed water use includes use in commercial building and residential buildings. Commercial building reclaimed water is water reclaimed from a specific building or several specific buildings, such as hotels, restaurants, and office buildings. Residential reclaimed water is a reclaimed water system from residential

areas, schools, and governmental agencies. Wastewater discharge and reuse from industrial buildings can be categorized as reclaimed water, but the wastewater from these buildings and treatment processes is not within the definition of reclaimed water discussed in this chapter [4].

This chapter discusses building reclaimed water systems, particularly focusing on the water balance and energy consumption relationship in a reclaimed water system for the hotel industry in Beijing.

### 3 Reclaimed Water Use in Beijing

An average annual precipitation for Beijing is 585 mm; total freshwater resource is 37.39 billion cubic meters ( $\text{m}^3$ ). Available water resources, per capita, is about  $118 \text{ m}^3$ , only 1/20 of China's per capita water resources ( $2300 \text{ m}^3$ ) and 1/63 of the world's per capita water resources ( $7400 \text{ m}^3$ ). Beijing suffers from a severe water shortage.

Reclaimed water is widely used in Beijing to meet increased water demand and has become the second largest multipurpose source of water in Beijing. In 2014, the amount of reclaimed water usage reached 800 million  $\text{m}^3$ , accounting for 22 % of total water consumption. Of the 800 million  $\text{m}^3$ , industrial utilization is 160 million  $\text{m}^3$ , agriculture utilization is 200 million  $\text{m}^3$ , lakes and landscape utilization is 400 million  $\text{m}^3$ , and green irrigation, car washing, dust, and other municipal utilization account for 40 million  $\text{m}^3$ . With respect to industry, all power plants in Beijing now use reclaimed water for cooling purposes, and reclaimed water plays an important role in ensuring the power plant's normal operation. With respect to the environment, the water quality of reclaimed water is good. Currently, 25 organizations use reclaimed water for environmental purposes such as lakes and landscape supply water, including Qing River, Summer Palace, Tucheng Ditch, Qing Yang River, Erdao Ditch, Gan Yu Bridge, the Southwestern Moat, etc.

Beijing's reclaimed water utilization consists of large, medium, and small scales, all equally important, combining the principles of centralization and decentralization. While planning and constructing the urban-centralized wastewater treatment facilities, the government actively promotes construction of reclaimed water facilities that take advantage of local conditions.

As of 2013, there were 792 operating reclaimed water facilities in Beijing. The capacity of reclaimed water facilities range from, generally, 50 to  $500 \text{ m}^3/\text{d}$ , with total processing capacity of  $240,000 \text{ m}^3/\text{d}$ . The actual amount of daily water processing in Beijing is about 10 million  $\text{m}^3$ . Annual reclaimed water utilization is 3670 million  $\text{m}^3$ . Reclaimed water facilities are mainly built in restaurants, hotels, and universities. With the development climax in Beijing's residential buildings, construction of reclaimed water facilities in residential buildings has gradually increased. The sources of reclaimed water are mainly wastewater from bath, toilet, and other miscellaneous uses. After wastewater treatment to meet water

quality standards, reclaimed water is mainly reused for toilet flushing, car washing, greening, landscaping, and supplementing rivers and lakes.

## **4 Research Methods**

Reclaimed water reuse in hotels falls under the category of decentralized water systems. Decentralized reclaimed water systems differ from urban wastewater treatment plants in design capacity, treatment process, raw water quality, and other aspects. Decentralized systems for reclaimed water use are smaller with better raw water quality and deploy a simple but advanced water treatment process. Raw water sources for hotel reclaimed water systems are generally from guest room bath drains, employees' baths, toilets, air conditioner drainage, and other miscellaneous drainage and have better quality compared to municipal wastewater. To ensure the best processed water quality at optimum cost, hotels generally use biological contact oxidation, membrane bioreactor (MBR), and other advanced treatment processes.

### ***4.1 Field Survey for Hotel Selection***

Survey results from the research team's previous projects were used as preliminary data. In addition, preliminary survey data were available from three other sources: Beijing Municipal Bureau of Tourism Research Group, Beijing City Water Conservation Management Center, and the County Water Conservation Hotel Management Office. These survey reports were used to compile a list of hotels with water treatment facilities. From a total of 632 hotels, 206 hotels had built-in water treatment facilities. The main survey approach included the following steps:

1. Hotel selection – a questionnaire (Appendix A) was developed to select the hotels to be included in the reclaimed water study.
2. Determining the survey sample – 30 hotels having reclaimed water systems were selected from 206 hotels for a detailed survey. However, three hotels did not meet the objective of investigation. Therefore, 27 hotels participated in the comprehensive survey.
3. Designing reclaimed water use questionnaire – the questionnaire (Appendix B) was designed according to structural characteristics of hotel reclaimed water systems. Two hotels were selected to conduct a pre-survey. Using pre-survey results, the questionnaire was supplemented and amended to make the survey as comprehensive as possible for all aspects of water and energy systems and to make sure the questionnaire was reasonable and operable.
4. Expert consultation – water management experts were consulted to enhance data reliability.



5. Managerial communication – communication with hotel managers to obtain the required data in the questionnaire.
6. Organizing and analyzing data using statistical tools (SPSS software).

## 4.2 Analysis of Hotel Reclaimed Water Reuse System

### 4.2.1 Hotel Water Consumption Characteristics

Table 1 shows various water uses in hotels compared to residential and other buildings.

According to GB/T 50331-2002, “The standard of water quantity for city’s residential use,” Beijing residents’ per capita daily water consumption is 85–140 L/d, and average monthly water consumption is 2.6–4.2 m<sup>3</sup> [5]. In contrast with this standard, Beijing hotel water usage far exceeds ordinary residential water use. Different star-level hotels show significant variations in water use. Hotel water use statistics, using 5 years (2008–2013) of data, show average water use for one-star to two-star hotels, 11.6 m<sup>3</sup>/bed-month; for three-star hotel, 17.6 m<sup>3</sup>/bed-month; and for four-star and above hotel 25.2 m<sup>3</sup>/bed-month, which are approximately 2.8 times, 4.2 times, and 6 times that of household water use, respectively.

Figure 1 shows a hotel’s major water use categories. According to the survey data noted above, the major water usages in a hotel are guest rooms, cafeteria, restaurant, bathroom, laundry, and central air conditioning, accounting for more than 85 % of total water usage. Guest rooms constitute the majority of hotel water usage, but that proportion of total water consumption is decreasing. However, other usage areas’ proportion of the total water consumption is increasing. The higher the star rating of a hotel, the higher quality of service provided. Hence, with the service development from single accommodation to integrated service, i.e., accommodations for catering, entertainment, and other higher quality services, the water usage due to these additional services is significantly increased. In addition, the higher the star rating, the higher demand for restaurant food, guest room bed cleanliness, hotel interior cleanliness, service staff personal hygiene, and green environment.

**Table 1** Proportion (%) of water usage for various use categories in several types of buildings [4]

Category	Residence		Hotel		Office building	
	Water amount (L/(p·d))	Ratio (%)	Water amount (L/(p·d))	Ratio (%)	Water amount (L/(p·d))	Ratio (%)
Toilet	40 ~ 60	31 ~ 32	50 ~ 80	13 ~ 19	15 ~ 20	60 ~ 66
Kitchen	30 ~ 40	21 ~ 23				
Bath	40 ~ 60	31 ~ 32	300	71 ~ 79		
Wash	20 ~ 30	15	30 ~ 40	8 ~ 10	10	34 ~ 40
Total	130 ~ 190	100	380 ~ 240	100	25 ~ 30	100

Note: *p* represents person, *d* represents day

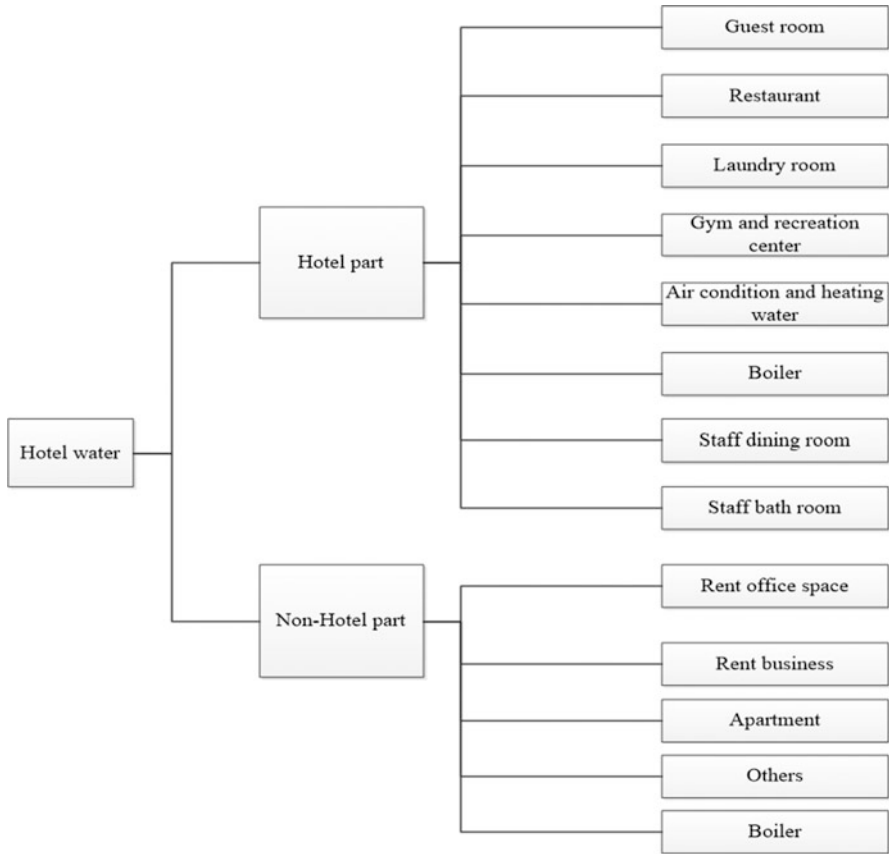


Fig. 1 Water use categories in a typical hotel (Source: first and second authors)

### 4.2.2 Water Balance Diagram

A water balance diagram expresses water balance in the reclaimed water system. The diagram uses graphs and figures to show collection, storage, handling, and usage relationships. A water balance diagram has no single mode. Its major purpose is to express reclaimed water collection and storage, reasonable allocation, and utilization. Figure 2 shows a water balance diagram for a reclaimed water system design.

The components of the water balance diagram are as follows:

- J、 $J_1 \sim J_4$  total amount of tap water supply and various components
- ZJ、 $ZJ_1 \sim ZJ_3$  reclaimed water supply and various components
- $P_1$ 、 $P_{11} \sim P_{13}$  total amount of reclaimed raw water and various components
- $P_2$ 、 $P_{21} \sim P_{23}$  direct discharge of sewage and various components
- $Q_1$  raw reclaimed water to regulator storage

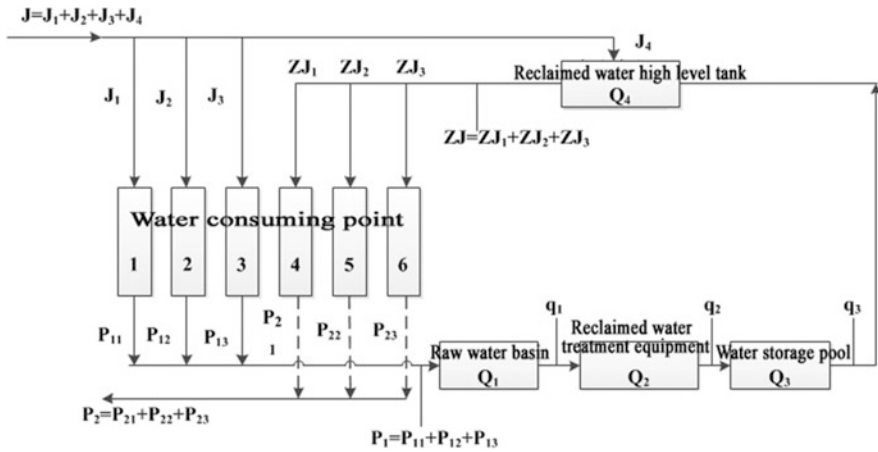


Fig. 2 Water balance diagram for reclaimed water system (Source: second author)

- $Q_2$  water yield of reclaimed water after treatment
- $Q_3$  treated reclaimed water to regulator and storage
- $Q_4$  high water level transfer water storage tank
- $q_1$  reclaimed water volume to water treatment unit
- $q_2$  reclaimed water yield from water treatment unit
- $q_3$  reclaimed water storage tank

### 4.2.3 Estimating Wastewater Drainage Volume

Wastewater drainage from a building provides the maximum amount of raw water for reuse. Direct wastewater drainage measurement from various types of buildings is rather difficult. However, wastewater drainage for different building types can be estimated in accordance to the type of building and the proportion of water supply use (generally 80–90 %). Wastewater drainage from a building can be calculated according to Eq. (1):

$$Q_y = \sum c \cdot b \cdot Q_d \quad (1)$$

- $Q_y$  building wastewater drainage ( $m^3/d$ )
- $c$  reduction factor to calculate the available wastewater drainage (generally 80–90 %)
- $b$  proportion (%) of water supplies for various use categories (from Table 1)
- $Q_d$  water supply quantity of building ( $m^3/d$ )

#### 4.2.4 Estimating Reclaimed Water Use Volume

Reclaimed water use amount for various water use types can be calculated as follows:

1. Residential and public flushing toilet water use:

$$Q_3 = \sum q_3 \times F_3 \times 10^{-3} \quad (2)$$

- $Q_3$  flushing water use volume ( $m^3$ )  
 $q_3$  flushing water consumption volume standard per unit area ( $L/(m^2 \cdot d)$ )  
 $F_3$  building area ( $m^2$ )

Residential flushing water standard is  $1.5 L/(m^2 \cdot d)$ , and public building flushing water standard is  $3 L/(m^2 \cdot d)$ .

2. Street flushing, landscaping, and road cleaning water amount can be calculated according to water use intensity:

$$Q_s = 0.001 h \cdot s \cdot n \quad (3)$$

- $Q_s$  street flushing water amount and green water ( $m^3/d$ )  
 $h$  sprinkling intensity (mm), concrete pavement  $h = 1 \sim 5$  mm, dirt road  $h = 3 \sim 10$  mm, greening  $h = 10 \sim 50$  mm  
 $s$  road or green area ( $m^2$ )  
 $n$  every day flushing frequency, street flushing  $n = 2 \sim 3$  time, green  $n = 1 \sim 2$  time

3. Car wash water amount:

$$Q_q = \sum q \cdot n \cdot b \quad (4)$$

- $Q_q$  car wash water amount ( $L/d$ )  
 $q$  car wash water quota, cars  $250 \sim 400 L/(\text{vehicles} \cdot d)$ , buses, trucks  $400 \sim 600 L/(\text{vehicles} \cdot d)$   
 $n$  car total number  
 $b$  washing rate frequency

#### 4.2.5 Reclaimed Water System Water Balance Index

The water balance index ( $\beta$ ) indicates a safety factor (coefficient) for reusing reclaimed water. Smaller  $\beta$  values show a higher safety of reclaimed water system operation, i.e., the higher rates of hotel wastewater reuse, the higher degree of utility, the better stability and efficiency. The water balance index can be calculated according to the following steps:

1. Determine water use objectives and raw reclaimed water manifold objectives within the target building – bathing, washing, laundry, and toilet water. When there is no actual measurement, the proportion of domestic water consumption can be determined according to the various types of buildings.
2. Calculate the total amount of used water in the raw reclaimed water:

$$Q = \sum Q_y \quad (5)$$

$Q$  the total amount of used water accumulated in the raw reclaimed water ( $\text{m}^3/\text{d}$ )  
 $Q_y$  types of used water flow can be set ( $\text{m}^3/\text{d}$ ) from Eq. (1)

3. Calculate the total amount of reclaimed water usage according to Eqs. (2), (3), and (4).
4. Compare the amount of used water flow with the amount of reclaimed water usage to build the index:

$$\beta = \frac{|Q - Q_z|}{Q_z} \quad (6)$$

$Q_z$  total quantity of reclaimed water used  
 $\beta$  the safety coefficient of raw water and reclaimed water

### 4.3 Analysis of Hotel Energy Use for Reclaimed Water System

Analysis of energy characteristics includes determining hotel reclaimed water systems energy consumption per unit of water use, the corresponding relationship between the amount of reclaimed water and its pollutant strength, and the main energy use points.

### 4.3.1 Reclaimed Water System Energy Consumption Model

Energy use intensity of hotels' reclaimed water systems, also known as specific energy consumption, refers to the amount of energy consumed by wastewater treatment units ( $\text{kWh/m}^3$ ). For the overall energy use level, other major energy-consuming aspects of the system, such as auxiliary lighting electricity consumption sites, should be included in calculation in addition to energy use for the water treatment system. The following formula can be used to calculate energy use for a hotel's reclaimed water system:

$$e = \frac{W_1 \cdot t_1 + W_2 \cdot t_2 + W_3 \cdot t_3 + W_4 \cdot t_4 + W_5 \cdot t_5 + W_6 \cdot t_6 + W_{\text{other}} \cdot t_7}{Q_p} \quad (7)$$

$e$	energy use intensity of reclaimed water system in hotel ( $\text{kWh/m}^3$ )
$W_1$	first-level lift pump rated power (kW)
$t_1$	first-level lift pump run time per day (h)
$W_2$	second-level lift pump rated power (kW)
$t_2$	second-level lift pump run time per day (h)
$W_3$	blower rated power (kW)
$t_3$	blower run time per day (h)
$W_4$	backwash pump rated power (kW)
$t_4$	backwash pump run time per day (h)
$W_5$	dosing pump rated power (kW)
$t_5$	daily dosing pump run time per day (h)
$W_6$	reuse pumps rated power (kW)
$t_6$	reuse pumps run time per day (h)
$W_{\text{other}}$	lighting and other parts of the rated power (kW)
$t_7$	other parts of the run time per day (h)
$Q_p$	actual processing volume of water in the water system of hotel ( $\text{m}^3/\text{d}$ )

## 5 Results and Discussion

Results for reclaimed water use systems discussed in this section include analysis of water balance and energy intensity for case study hotels in Beijing. Based on collected survey data, we used 34 hotels for water balance analysis. Because seven hotels refused to provide us with their energy data about reclaimed water systems, we selected 27 hotels for energy consumption analysis.

## 5.1 Water Balance Analysis

The concept of safety coefficient for reclaimed water system and safety coefficient theoretical and actual value analysis are discussed below.

### 5.1.1 Safety Coefficient of Reclaimed Water System

For each selected hotel, theoretical safety coefficient ( $\beta_T$ ) for reclaimed water use was calculated using formulas (1), (2), (3), (4), (5), and (6) and the questionnaire data. Actual safety coefficient ( $\beta_P$ ) for each hotel was calculated using real data obtained from field research.  $\beta_T$  values reflect the hotel reclaimed water system's normal safe operation at the theoretical level, i.e., the threshold of a reasonable assessment of the scope of the hotel could be a quantitative basis for effective functioning of the reclaimed water system;  $\beta_P$  value objectively characterizes the safety of the reclaimed water system of the hotel running status quo. It reflects the current gap in the hotel reclaimed water system operation process better than  $\beta_T$  value and the actual operational efficiency versus the theoretical level. In addition, it could effectively help find gaps in the hotel reclaimed water system in order to achieve the highest water conservation and improve energy utilization efficiency, thus making the system efficient and safe.

### 5.1.2 Safety Coefficient Theoretical Value( $\beta_T$ )

According to formula (6), the key factor in calculating  $\beta_T$  is the theoretical volume of raw water in the hotel reclaimed water system and the volume of reclaimed water used. Among the 34 hotels in the sample survey, for more than 90 % of the hotels, the raw water comes from bath drains, toilet drainage, air conditioning drainage, and laundry drains. Theoretically, the original amount of water for bath (including guests and staff baths), toilet, air conditioning, and laundry use is calculated based on the sample data and used as the basis for our analysis of the four uses. The proportion for these four uses of water to total water withdrawals in hotels is, respectively, about 50 %, 8 %, 6 %, and 6 %. Referring to Eq. (1), with a drainage water reduction factor of 0.85, the theoretical formula is:

$$Q_T = 0.85 \times (0.5 + 0.08 + 0.06 + 0.06) \times Q_d = 0.595Q_d \quad (8)$$

$Q_T$  theoretical raw water quantity in hotel reclaimed water system ( $\text{m}^3/\text{year}$ )  
 $Q_d$  total quantity of reclaimed water use in hotel ( $\text{m}^3/\text{year}$ )

Survey results show that hotel reclaimed water is mainly used for toilet flushing, landscaping, and car wash. In the theoretical calculation of the amount of water reuse, the main consideration includes these three purposes. The amount of water reuse is calculated as follows: toilet flushing with Eq. (2) (flushing water building area method, water standards take 3 L/(m<sup>2</sup>•d)); green water with Eq. (3) (the calculated intensity of sprinkler water application, total sprinkler water application intensity 30 mm, average daily applied over a number of times); and car wash water using Eq. (4) (rinse water takes 300 L/(vehicles•d)) estimating an average number of car washings per day at 10. According to the above calculations, the theoretical amount of water use for hotels is:

$$\begin{aligned}
 Q_{ZT} &= 365 \times (Q_c + Q_s + 0.001Q_q) \\
 &= 365 \times (3 \times F_c \times 10^{-3} + 0.001 \times 30 \times S \times n + 0.001 \times 300 \times 10) \quad (9) \\
 &= 1.095F_c + 10.95S \times n + 1095
 \end{aligned}$$

- $Q_{ZT}$  hotel theoretical amount of reclaimed water use (m<sup>3</sup>/a)
- $Q_c$  flushing water (m<sup>3</sup>/d)
- $Q_q$  car washing water (L/d)
- $F_c$  hotel footage area (m<sup>2</sup>)
- $S$  hotel green area (m<sup>2</sup>)
- $N$  the number of times per day sprinkled (includes the amount of water loss)  
 $n = 2 \sim 3$  times, as referenced in sprinkled green <lawn saving irrigation technical requirements (DB11/T 349-2006)> irrigation frequency and period provided [6]

According to formulas (1), (2), (3), and (4), we can calculate the theoretical value of raw water for the original sample set and use reclaimed water in every hotel. According to the formula (6), we can calculate the coefficients of each hotel theoretical value ( $\beta_T$ ), and the results are shown in Table 2. Thus, we can further analyze the statistical regularities of  $\beta_T$  coefficient characteristics.

SPSS software was used for descriptive statistical analysis of the  $\beta_T$  value for the 34 hotels' reclaimed water systems. Results are shown in Table 3. The mean value for  $\beta_T$  coefficients, concentrated sample reclaimed water systems, is about 0.46. According to the definition of the  $\beta_T$  coefficient, when a  $\beta_T$  value is smaller, closer

**Table 2**  $\beta_T$  value for each sample hotel's reclaimed water system

Number	1	2	3	4	5	6	7	8	9	10	11	12
$\beta_T$	0.36	0.35	0.87	0.37	0.36	0.61	0.36	0.48	0.30	0.50	0.13	0.76
Number	13	14	15	16	17	18	19	20	21	22	23	24
$\beta_T$	0.78	0.72	0.61	0.22	0.19	0.91	0.93	0.38	0.58	0.14	0.07	0.74
Number	25	26	27	28	29	30	31	32	33	34		
$\beta_T$	0.26	0.33	0.93	0.58	0.30	0.02	0.21	0.09	0.25	0.98		



**Table 3**  $\beta_T$  coefficient values descriptive statistics

		Statistic	SE
Mean value		0.46	0.05
95 % confidence interval	Lower limit	0.36	
	Upper limit	0.56	
5 % trimmed mean		0.46	
Median		0.37	
Variance		0.08	
Standard deviation		0.28	
Minimum		0.02	
Maximum		0.98	
IQR		0.48	
Coefficient of skewness		0.44	0.40
Kurtosis coefficient		-0.88	0.79

**Table 4** Overall hotel samples' reclaimed water system  $\beta_T$  value

Pass rate (%)	10	20	30	40	50	60	70	80	90	95
$\beta_T$	0.10	0.22	0.31	0.39	0.46	0.53	0.61	0.70	0.82	0.92

to a value of 0, this indicates higher system safety. The higher  $\beta_T$  for a reclaimed water system, the higher the reclaimed water use efficiency. The mean level of our sample is slightly lower than 0.5 ( $\beta_T$  values between 0 and 1), with overall high safety and high efficiency water reuse. The minimum value of  $\beta_T$  is 0.02, for all our samples, so, theoretically, raw water and reclaimed water use is fair. This system can collect high-quality miscellaneous drainage within the hotel, as much as possible. After treatment, it meets the various parts for possibly replacing freshwater use with that of reclaimed water.  $\beta_T$  maximum value is 0.98 which means that the theoretical amount of water is roughly equivalent to about half the original quantity, i.e., recycling rate is relatively low.

Using probability calculation theory to calculate the probability of the sample, the distribution of  $\beta_T$  coefficient in hotel overall reclaimed water systems can be estimated. Table 4 shows these calculation results.

Table 4 shows that for about 10 % of all Beijing hotels with reclaimed water systems,  $\beta_T$  is less than 0.1; for about 20 % of hotel reclaimed water systems,  $\beta_T$  value is less than 0.22; and for about 50 % of hotel reclaimed water systems,  $\beta_T$  value is less than 0.46. As shown, the theoretical value of the insecure coefficient  $\beta_T$  is less than 0.5, which is about half of all reclaimed water systems in Beijing hotels. The  $\beta$  value is smaller, which means higher safety for reclaimed water systems. At present, theoretically, most of the investigated hotels in Beijing have good conditions in the design of their reclaimed water systems. In addition, we can now calculate the  $\beta_T$  value of a reclaimed water system prior to its design, as a reference standard to assess system operation security, stability, and efficiency levels.

### 5.1.3 Safety Coefficient Actual Value ( $\beta_p$ )

In comparison to the theoretical value ( $\beta_T$ ), the calculation method for the actual value of the  $\beta$  coefficient ( $\beta_p$ ) is relatively simple. Detailed data is available from the field survey of the 27 hotels, for the four water uses, i.e., bath, toilet, air conditioning, and laundry, where drainage reduction factor is 0.85. Therefore, the equation for the original amount of reclaimed raw water can be expressed as:

$$Q_p = 0.85 \times (W + G + K + X) \tag{10}$$

- $Q_p$  hotel actual raw reclaimed water amount (m<sup>3</sup>/year)
- $W$  bath water (including guests and staff bath) withdrawal (m<sup>3</sup>/year)
- $G$  toilet water withdrawals (m<sup>3</sup>/year)
- $K$  air conditioning water use (m<sup>3</sup>/year)
- $X$  laundry water withdrawals (m<sup>3</sup>/year)

The actual hotel reuse water volume,  $Q_{zp}$ , obtained directly from the field survey of 27 hotels, is an important indicator of the actual amount of reused water and does not have to be calculated.

The coefficient actual value ( $\beta_p$ ) can be calculated according to Eq. (6) using actual raw reclaimed water amount ( $Q_p$ ) from Eq. (10) and the actual amount of the reclaimed water ( $Q_{zp}$ ) in the hotel reclaimed water system. Results are shown in Table 5.

Using SPSS software for the statistical analysis, the sample  $\beta_p$  coefficient mean value is 0.95, which is about 2.1 times of the sample theoretical mean coefficient  $\beta_T$ . The minimum sample coefficient is 0.10, and maximum value is 3.12, a difference of nearly 31 times from  $\beta_T$ . Table 6 shows estimates for  $\beta_p$  sample probability coefficient.

**Table 5**  $\beta_p$  values for each sample in the hotel reclaimed water system

Number	1	2	3	4	5	6	7	8	9	10	11	12
$\beta_p$	0.95	1.97	1.40	0.58	0.45	0.85	1.05	0.95	0.45	1.35	0.35	0.85
Number	13	14	15	16	17	18	19	20	21	22	23	24
$\beta_p$	1.56	2.35	1.89	0.56	0.34	1.04	3.12	0.67	1.28	0.42	0.1	0.95
Number	25	26	27									
$\beta_p$ value	1.09	0.93	0.65									

**Table 6**  $\beta_p$  value of the probability values for hotel reclaimed water system samples

Pass rate (%)	10	20	30	40	50	60	70	80	90	95
$\beta_p$	0.11	0.40	0.61	0.79	0.95	1.12	1.30	1.5	1.79	2.03

The probability calculation results show that in all hotels' reclaimed water systems, the reclaimed water system coefficient value ( $\beta_p$ ) is less than 0.11 for about 10 % of the hotels, less than 0.4 for about 20 % of the hotels, and less than 0.95 for 50 % of the hotels. These coefficient values,  $\beta_p$ , are greater than the overall sample corresponding coefficient value ( $\beta_T$ ), which indicates that actual water reuse amount is less than the original overall reclaimed water in actual hotel operating systems. In addition, when comparing the sample  $\beta_T$  coefficient values, we find that it has failed to fully consider the available raw water treatment and reuse capability and maximize the actual reuse amount in hotels in the design process for reclaimed water systems. Therefore, it fails to maximize water saving and pollution treatment capability of the system.

### 5.2 Energy Use Analysis

The energy intensity in reclaimed water systems and other aspects of major energy-consuming components of the systems were analyzed using the field survey data.

#### 5.2.1 Energy Consumption Characteristics

The main energy-consuming pumping stations of hotel reclaimed water systems are shown in Fig. 3 and described below.

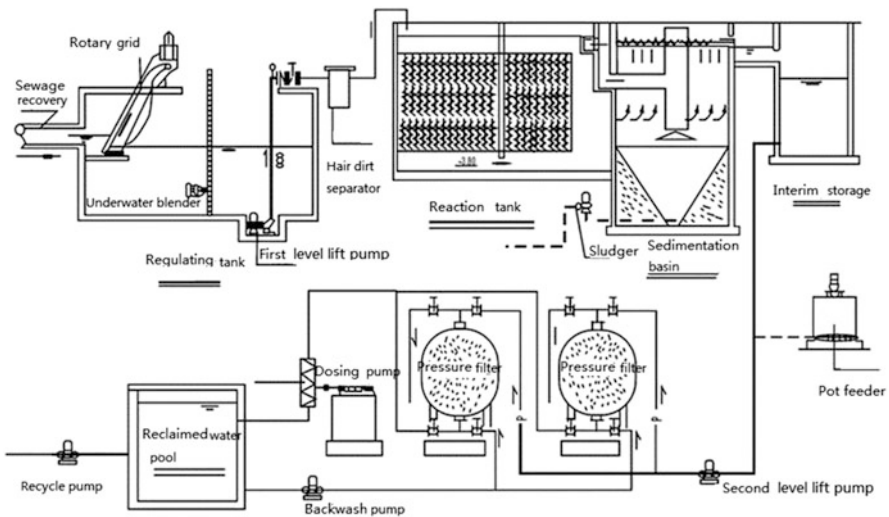


Fig. 3 Water flow chart and energy use points in a hotel reclaimed water system (Source: [4])

**First-Level Lift Pump**

First-level lift pump delivers raw water from regulating storage tank to the reaction tank. The first-level lift pump power rating ranges from 0.75 to 5.5 kW, and its run time ranges from 4 to 8 h a day, depending upon the volume of the tank and the reaction tank size.

**Second-Level Lift Pump**

Second-level lift pump delivers water from the sedimentation tank to the filter canister. The second-level pump power rating ranges from 0.4 to 2.2 kW, and its run time ranges from 6 to 12 h a day, depending upon the settling tank and canister volume size. Under normal circumstances, a hotel uses two secondary lift pumps.

**Blower**

Blower devices deliver oxygen to the reaction tank. Its power rating ranges from 0.55 to 5.5 kW. Under normal circumstances, a hotel installs two blowers and is prepared to respond to unexpected situations. Blower devices operate 24 h per day and is the main energy-consuming equipment in a reclaimed water use system.

**Backwash Pump**

Backwash pump delivers treated reclaimed water to clean the reaction tank. Its power rating ranges from 0.4 to 5.5 kW. In general, the reaction tank cleaning is performed every 2 days, and it operates about 5–10 min each time.

**Dosing Pump**

Dosing pump is located between the filter canister and the reclaimed water pool which automatically injects disinfectants to improve water quality. The dosing pump power rating is small, ranging from 0.02 to 0.2 kW and operating 24 h per day.

**Recycle Pumps**

Recycle pumps deliver treated reclaimed water to the storage tank for distributing to hotel water use points. The power rating of a reuse pump is rather large, ranging from 5.5 to 12 kW and operating 2–6 h per day.

**5.2.2 Energy Intensity Estimation**

Energy data obtained from the surveys are substituted into Eq. (7) to calculate the energy intensity value for the 27 hotels’ reclaimed water systems. Results are shown in Table 7. The minimum energy intensity of these reclaimed water systems

**Table 7** Energy intensity (kWh/m<sup>3</sup>) of hotels’ reclaimed water system

Sample	1	2	3	4	5	6	7	8	9	10	11	12	13	14
Energy intensity	0.35	0.44	0.84	0.74	0.82	0.66	0.76	0.91	1.60	1.62	0.76	0.51	1.91	0.24
Sample	15	16	17	18	19	20	21	22	23	24	25	26	27	Mean
Energy intensity	1.04	0.72	1.56	1.15	1.62	0.88	0.44	1.37	1.91	1.66	1.79	0.65	0.62	1.02

is  $0.24 \text{ kWh/m}^3$ , and the maximum is  $1.91 \text{ kWh/m}^3$ . The average energy intensity is  $1.02 \text{ kWh/m}^3$ , which is 3.5 times higher than the urban wastewater treatment plant average energy intensity ( $0.29 \text{ kWh/m}^3$ ). Thus, reclaimed water system energy intensity for hotels is much higher than an urban wastewater treatment plant. According to Beijing's actual processing capacity of hotel reclaimed water systems ( $8687 \text{ m}^3/\text{d}$ ), the estimated power consumption of reclaimed water systems for all hotels in Beijing six districts, for the year 2013, was approximately 3,234,000 kWh.

### 5.2.3 Analysis of Energy Intensity and Reclaimed Water Relationship

There are numerous reports on energy-related research of wastewater treatment systems [7–16]. For our study, reclaimed water system data for 27 hotels in Beijing were used to perform regression analysis (SPSS software) to quantify the relationship between the amount of reclaimed water in the actual processing system and energy intensity. The power function regression can be expressed as follows:

$$e = 5.32Q_p^{-0.393} \quad (11)$$

$e$  the energy intensity of hotel reclaimed water system ( $\text{kWh/m}^3$ )  
 $Q_p$  the actual processing capacity of hotel reclaimed water system ( $\text{m}^3/\text{d}$ )

Significant probability,  $p$ , of the test of equations and parameters was less than 0.01 level of significance, and the goodness of fit 0.89 is well fitted. Equation (11) shows that the actual processing capacity of reclaimed water systems effect on the energy intensity of reclaimed water systems. With the increase of actual processing capacity for reclaimed water systems, the system energy intensity decreases. The energy intensity can be reduced by 24 % if the amount of the actual processing capacity of reclaimed water systems is doubled. The processing capacity of hotel reclaimed water systems is an important scale design parameter, which reflects the processing ability of the reclaimed water system. Equation (12) was developed using our data (27 hotels) for the design capacity and energy intensity relationship:

$$e = 5.45Q_d^{-0.458} \quad (12)$$

$e$  the energy intensity of hotel reclaimed water system ( $\text{kWh/m}^3$ )  
 $Q_d$  the designed processing capacity of hotel reclaimed water systems ( $\text{m}^3/\text{d}$ )

As is shown, the coefficient index in Eq. (11) exceeds the coefficient index in Eq. (12), while the power coefficient is smaller in Eq. (12). So while increasing designed processing capacity and the actual processing amount of hotel reclaimed water systems, the designed processing capacity of the corresponding energy consumption intensity decreases faster. Since the actual processing capacity of hotel reclaimed water systems is generally lower than the designed processing capacity, making the actual processing amount close to the designed processing capacity is one way to reduce energy consumption in hotel reclaimed water systems.

### 5.2.4 The Main Energy Consumption Points

Table 8 shows the analysis results for power consumption intensity of the main energy consumption use points in hotel reclaimed water systems. As shown in Table 8, the average total installed power capacity of hotel reclaimed water systems is about 38.6 kW, and the average used power is about 20.235 kW. The average energy consumption intensity corresponding to hotel reclaimed water systems (i.e., energy intensity) is 1.02 kWh/m<sup>3</sup>. Blower system energy consumption for the reclaimed water systems' reaction tank oxygen aeration accounts for 59.5 % of all energy consumption and is the largest energy-consuming processing unit for the whole system – energy intensity, whose power consumption intensity is 0.596 kWh/m<sup>3</sup>. The energy consumption of recycle pumps is the second most energy-consuming unit – accounting for 24.5 %, energy intensity is 0.25 kWh/m<sup>3</sup>. For these two devices, energy consumption accounts for 84 % of the entire reclaimed water system – the main energy points. Therefore, these two devices can be adjusted for operating time, to increase energy-saving potential of the system and, thus, achieve energy conservation in hotel reclaimed water systems.

**Table 8** Energy consumption for each component of hotel reclaimed water systems

Energy consumption component	Average total installed power (kW)	The average use of installed power (kW)	Energy consumption intensity (kWh/m <sup>3</sup> )	Total power consumption ratio (%)
First-level lift pump	3	1.5	0.064	6.2
Second-level lift pump	4.5	2	0.060	5.9
Blower	11	5	0.596	59.5
Backwash pump	3.6	2.8	0.015	1.5
Dosing pump	0.1	0.035	0.012	1.1
Recycle pump	16	8.5	0.250	24.5
Lighting and other energy consumption	0.4	0.4	0.023	2.3
Total	38.6	20.235	1.02	100

## 6 Conclusions

This investigation demonstrates that the energy use intensity of reclaimed water systems is inversely related to the size of the hotel, i.e., the larger the hotel, the smaller the energy use intensity. As such, making the actual amount of water treatment capacity close to its design capacity is an effective energy efficiency measure to reduce energy use intensity. This investigation shows that the main energy use points in hotel reclaimed water systems are blower devices and backwash pumps. Thus, for energy-saving purposes, it is necessary to optimize the operation of blowers and recycle and backwash pumps:

### 1. Water balance, imbalance, and adjustment

In reality, the design and actual operation condition in hotels' reclaimed water systems differ greatly. For example, occupancy rate and other factors cause water use imbalance in the system which needs to be adjusted. Depending on the specific condition, the following adjustment methods are recommended:

#### (a) Improve system operation

Poor operation conditions result from improper initial design. Operation problems may include but are not limited to low storage volume and too low or too high raw water pump flow capacity. Accordingly, to improve operation efficiency, the need exists to adjust the raw water pump flow and control initial water level while storing more tap water in order to minimize the water storage space.

The initial design of a large hotel reclaimed water system is illustrated, here, as an example. In this hotel, the processing design capacity is very large, 25 m<sup>3</sup>/h, and the original water pump capacity is 30 m<sup>3</sup>/h. The original water pump has a dual control, and tap water supplement control float valve was set up, in error, in the reclaimed water pool to meet the needs of reclaimed water uses. This practice resulted in tap water being added to the entire pool volume for storage purposes. As such, the reclaimed water pool was often in the full stage, the original raw water pump action was insignificant, and the conditioning tank often overflowed, making it difficult to collect and process the entire wastewater volume. Since there is sufficient wastewater processing unit capacity, this problem was corrected by switching the raw water pump operation to 4 m<sup>3</sup>/h and setting the priming level on the appropriate position. And we set the conditioning tank water level to control the raw water pump operation mode. Besides, we set the closing situation of floating ball valve which controls the tap water supplement to the lower water level. Through taking above measures, this reclaimed water system would run steadily.

#### (b) Improve water treatment potential capacity

The reclaimed water treatment system (reaction tank) has a large unused processing capacity. There is also sufficient space in the reclaimed water pool. But when reclaimed water use requirements increase and new raw water resources can be obtained, the space of conditioning tank volume

cannot increase. The increase of processing potential and reclaimed water recovery can be achieved by increasing the flow of raw water pump and adjusting the priming level accordingly.

For illustration purposes, the large hotel reclaimed water system can be used again as an example. When the amount of reclaimed raw water meets the design requirements, 200 m<sup>3</sup>/d, according to water flow laws, one can assume only proportional constant flow increase. The hotel reclaimed water system is running at an average flow rate of 8.3 m<sup>3</sup>/h under 24 h of continuous operation. The system regulator needs to increase tank volume from 14.95 to 32.5 m<sup>3</sup> in order to ensure that all reclaimed raw water is collected and treated. If the pump flow is increased to 10 m<sup>3</sup>/h, all reclaimed raw water can be processed and at the same time the anhydrous ammonia spill can be avoided.

(c) Retrofit

For some reclaimed water systems, already running at full capacity, water system expansion needs to be considered when the amount of reclaimed raw water increases. Two options are available – one is regulating the conditioning tank and reaction tank at the same time and replacing the original pump. The second is a reaction tank expansion and replacement of the original pump. Between these two options, the most economical to implement should be selected.

2. Energy saving

(a) Blower device selection

As stated earlier, blower devices used in treatment process are major energy users in the system. Therefore, selecting a blower device will result in a big difference in power consumption. Aerator is the device which supplies diffused air to biological oxidation pool. Different types of aerators, perforated pipe, spiral aerator, porous aeration, and aeration porous tubes, are available. Different aeration heads create differences in oxygen utilization; a microporous aerator has the highest oxygen utilization. Using a higher oxygen utilization, aeration blower head can cause a significant decline in energy consumption.

(b) Blower device maintenance and management

The role of proper maintenance and management of the blower for energy saving cannot be ignored. The blower device must be carefully managed and maintained. For example, blower outlet clogging can cause poor air supply and increased energy consumption.

(c) Optimal combination of aeration device and padding

Biological contact oxidation tank carries a large number of microbial species. Optimal combinations of different types of aeration device and species can improve oxygen utilization and energy use efficiency and indirectly affect blower energy consumption.

(d) Optimal allocation reuse pumps

The amount of reclaimed water use for hotel reclaimed water systems often fluctuate over time and season. If we accept the current maximum flow



rate as a basis for selecting a pump, the pump running time, at full speed, will not exceed 10 %. Most of the time, it can't be operated efficiently, resulting in energy waste. Thinking about the upgrade pump selection and matching, drive mode selection, system maintenance, and other issues, we summarize that the key to reduce energy consumption of lift pump is to control the way of the overall system operation and process. Energy savings can occur if hotels implement the optimal control of upgrade process. More than one pump can be used for position control, speed control, automatic flow grouping multi-unit control and other methods.

### Appendix A: Questionnaire – Hotel Reclaimed Water Facilities in Beijing

Hotel name			Address			Zip code	
Department of property management			Preparer			Telephone	
Water facilities built time	____year	Floor space	_____m <sup>2</sup>	Designed capacity	_____m <sup>3</sup> /d		
The actual processing	_____m <sup>3</sup> /d	The actual amount back	_____m <sup>3</sup> /d	Supply water rate	_____m <sup>3</sup> /d		
Treatment process	<input type="checkbox"/> bio-contact oxidation <input type="checkbox"/> activated sludge process <input type="checkbox"/> biological rotary method <input type="checkbox"/> biofilm process <input type="checkbox"/> MBR <input type="checkbox"/> physic-chemical method <input type="checkbox"/> else_____						
Raw water source	<input type="checkbox"/> bathing wastewater <input type="checkbox"/> lavatory drain <input type="checkbox"/> Air conditioning drainage circulating cooling system <input type="checkbox"/> condensate water <input type="checkbox"/> The swimming pool drainage <input type="checkbox"/> laundry drains <input type="checkbox"/> kitchen drainage <input type="checkbox"/> Flushing drainage <input type="checkbox"/> rain <input type="checkbox"/> else:						
Reclaimed water use	<input type="checkbox"/> flush the toilet <input type="checkbox"/> Greening <input type="checkbox"/> landscape water <input type="checkbox"/> Ground flush (clean-keeping) <input type="checkbox"/> car washing <input type="checkbox"/> else:						
Water inflow change condition	①spring: <input type="checkbox"/> more <input type="checkbox"/> less	change of water use	①spring: <input type="checkbox"/> more <input type="checkbox"/> less	①spring: <input type="checkbox"/> more <input type="checkbox"/> less			
	②summer: <input type="checkbox"/> more <input type="checkbox"/> less		②summer: <input type="checkbox"/> more <input type="checkbox"/> less	②summer: <input type="checkbox"/> more <input type="checkbox"/> less			
	③autumn: <input type="checkbox"/> more <input type="checkbox"/> less		③autumn: <input type="checkbox"/> more <input type="checkbox"/> less	③autumn: <input type="checkbox"/> more <input type="checkbox"/> less			
	④winter: <input type="checkbox"/> more <input type="checkbox"/> less		④winter: <input type="checkbox"/> more <input type="checkbox"/> less	④winter: <input type="checkbox"/> more <input type="checkbox"/> less			
	①morning: <input type="checkbox"/> more <input type="checkbox"/> less		①morning: <input type="checkbox"/> more <input type="checkbox"/> less	①morning: <input type="checkbox"/> more <input type="checkbox"/> less			
	②noon: <input type="checkbox"/> more <input type="checkbox"/> less		②noon: <input type="checkbox"/> more <input type="checkbox"/> less	②noon: <input type="checkbox"/> more <input type="checkbox"/> less			
	③night: <input type="checkbox"/> more <input type="checkbox"/> less		③night: <input type="checkbox"/> more <input type="checkbox"/> less	③night: <input type="checkbox"/> more <input type="checkbox"/> less			
Construction investment:	_____yuan	Routine maintenance cost	_____yuan/a	Expenses for medicine	_____yuan/a		
Equipment investment:	_____yuan						
Electric charge	_____yuan/a	Cost of labor	_____yuan/a	Annual depreciation	_____yuan/a		
Water treatment costs	_____yuan/m <sup>3</sup>	Without odor in the water treatment station: <input type="checkbox"/> yes <input type="checkbox"/> no		Noise generated during operation facility disturb residents: <input type="checkbox"/> yes <input type="checkbox"/> no			

Without odor in the water treatment station: <input type="checkbox"/> yes <input type="checkbox"/> no		Acceptance of the use of reclaimed water about the total proportion of users: _____%
Whether conducted in water quality testing: <input type="checkbox"/> yes <input type="checkbox"/> no		
Effluent quality	①PH____ ②smell____ ③chromaticity____ ④turbidity____ ⑤TDS____mg/L ⑥BOD <sub>5</sub> ____mg/L	
	⑦ammonia nitrogen____mg/L ⑧ anionic surfactant____mg/L ⑨ iron____mg/L ⑩ manganese____mg/L	
⑪DO____mg/L ⑫ total residual chlorine____mg/L ⑬ total coliform group____piece/L		
For the current situation of water treatment facilities run condition of hotels in Beijing, water managers have any suggestions or ideas:		

### Appendix B: Questionnaire – Hotel Reclaimed Water Facilities’ Water Consumption and Water Treatment in Beijing

Name			Hotel star	_____star	
Address			Preparer	Telephone	
Water facilities built time	_____year	Design treatment capacity	_____m <sup>3</sup> /h _____m <sup>3</sup> /d	The actual amount of treatment and reuse	_____m <sup>3</sup> /d _____m <sup>3</sup> /a
Treatment method	<input type="checkbox"/> bio-contact oxidation <input type="checkbox"/> activated sludge process <input type="checkbox"/> biological rotary method <input type="checkbox"/> biofilm process <input type="checkbox"/> MBR <input type="checkbox"/> physic-chemical method <input type="checkbox"/> else_____			Facilities run time every day	
Facilities running days	_____d/a	Floor space	_____m <sup>2</sup>	Duration of service	_____year
Raw water source	<input type="checkbox"/> Guest bath <input type="checkbox"/> Staff bathroom <input type="checkbox"/> Guest room, the worker lavatory drainage④ <input type="checkbox"/> rain⑤ <input type="checkbox"/> air condition drainage⑥ <input type="checkbox"/> condensate water⑦ <input type="checkbox"/> The swimming pool drainage⑧ <input type="checkbox"/> else:				
Water use	<input type="checkbox"/> flush the toilet② <input type="checkbox"/> greenbelt③ <input type="checkbox"/> waterscape④ <input type="checkbox"/> Ground flush (clean-keeping) <input type="checkbox"/> car washing⑥ <input type="checkbox"/> else:				
Supply water rate	_____m <sup>3</sup> /d _____m <sup>3</sup> /a	Adjust the pool volume	_____m <sup>3</sup>	Reaction tank volume	_____m <sup>3</sup>
Tank volume	_____m <sup>3</sup>	Filtering tank volume	_____m <sup>3</sup>	Water storage tank volume	_____m <sup>3</sup>
Construction investment: equipment investment:	_____yuan _____yuan	Routine maintenance cost	_____yuan/a	Expenses for medicine	_____yuan/a
Electric charge	_____yuan/a	Cost of labor	_____yuan/a	Annual depreciation	_____yuan/a
Water cost	_____yuan/m <sup>3</sup>	Disinfectant type		Power consumption	_____degree/d
Hotel total power consumption	_____degree/d _____degree/a	Tier 1 improvement pump rated power and running time (regulating reservoir→ reaction tank)		_____KW _____hour/d	

The secondary lift pump rated power and running time (settling pond→filtering tank)		_____KW _____h/d	Blower power rating	_____KW _____h/d
Backwashing pump rated power and running time		_____KW _____h/d		
Dosing pump rated power and running time	_____KW _____h/d	Recycle pump rated power and running time (reclaimed water pool→ guest room etc.)		_____KW _____h/d
Other parts of the rated power and running time		① _____KW _____h/d ② _____KW _____h/d		
Effluent quality	①PH _____ ②smell _____ ③ chromaticity _____ ④turbidity _____ ⑤TDS _____mg/L ⑥ BOD <sub>5</sub> _____mg/L ⑦ ammonia nitrogen _____mg/L ⑧ anionic surfactant _____mg/L ⑨ iron _____mg/L ⑩manganese _____mg/L ⑪DO _____mg/L ⑫ total residual chlorine _____mg/L ⑬total coliform group _____piece/L			
Water treatment process:				
Remark (To illustrate the problem) :				

## References

1. Ma-xu F, Xu-de H (1996) Discussion of Beijing municipal water use. Beijing Energy Conserv 1:11–13
2. Owen WF (1989) Energy consumption and energy efficiency of sewage treatment. Zhang beeping, Chewu, Beijing. Energy Publishing, pp 7–9
3. Cao-wen F (2011) Building water system optimization research. Institute of urban construction and environmental engineering of Chongqing University master’s degree thesis, Chongqing
4. Zhang tong (2007) Architectural reclaimed water design technology. National Defense Industry Press, Beijing
5. The Ministry of Construction of the People’s Republic of China (2002) The standard of water quantity for city’s residential use. China Building Industry Press, Beijing
6. Beijing Water Authority (2006) Standards for efficient irrigation technology of turf. The Beijing Municipal Bureau of Quality and Technical Supervision, Beijing
7. Hagan EG, Roberts RM (1976) Energy requirements for wastewater treatment (Part 2). Water Sew Works 11:52–57
8. Imhoff KR (1983) Energy optimization in sewage and sludge treatment. Water Sci Technol 15 (Capetown):103–114
9. Jacobs A (1977) Reduction and recovery: keys to energy self-sufficiency. Water Sew Works 5:24–37
10. Selby KA, Puckorius PR (2004) The use of reclaimed water in electric power stations and other industrial facilities. Water Air Soil Pollut 90(1):26–35
11. Karlsson I (1996) Environmental and energy efficiency of different sewage treatment processes. Water Sci Technol 34(3–4):203–211
12. Lucilla G, Francisco PM, Frederick MD (2005) Agent-based control of a municipal water system. Springer, Berlin/Heidelberg. (3690):500–503
13. Middlebrooks EJ, Middlebrooks CH, Reed SC (1981) Energy requirement for small wastewater treatment system. J Water Pollut Control Fed 53(7):1172–1197

14. Zheng P-Y, Jun H, Guichun Y (2004) Treatment of organic compounds in reclaimed wastewater for groundwater recharge. *TsingHua Sci Technol* 9(4):455–459
15. Fredrich K, David RH (2008) China's water-energy nexus. *Water Policy* 10:51–65
16. Garber WF (1975) Energy-wastewater treatment and solids disposal. *J Env Eng Div ASCE* EE3:319–325

# Urban Stormwater Management: Evolution of Process and Technology

David Hirschman and Joseph Battiata

## Contents

1	Introduction .....	84
2	History of Stormwater Practice .....	85
2.1	The Pave and Drain Era .....	86
2.2	Stream Channel and Flood Protection .....	87
2.3	Natural Resource Protection .....	93
3	Stormwater, Site Planning, and Land Use .....	94
4	Reducing Stormwater Volume: A New Paradigm in Regulation and Design .....	97
4.1	Runoff Reduction Practices .....	98
4.2	Steps for the Runoff Reduction Method (RRM) .....	106
4.3	Accounting for Runoff Reduction Capabilities of Various Practices .....	109
5	Stormwater Management as an Interdisciplinary Field .....	110
6	Emerging Forms of Regulatory Integration .....	113
6.1	Runoff Volume .....	114
6.2	Stormwater Quality and Quantity .....	115
	Appendix A .....	116
	Appendix B .....	118
	References .....	119

**Abstract** The practice of urban stormwater management has evolved over the course of several decades. Initially, stormwater management concerned itself primarily with abating downstream flooding and was the sole domain of engineers. As the regulatory climate changed over time, so did design philosophy, along with the types of management practices, the computational methods, and the prominence of stormwater management as an integral part of the overall site planning process. The milestones of this evolution include the addition of stormwater quality treatment as a regulatory standard and, more recently, a focus on reducing the overall

---

D. Hirschman (✉)  
Center for Watershed Protection, Ellicott City, MD, USA  
e-mail: [djh@cwpp.org](mailto:djh@cwpp.org)

J. Battiata  
Hopewell, VA, USA

volume of runoff through the use of small-scale, distributed management practices (often under the banner of Low-Impact Development or Environmental Site Design). The volume reduction strategy, referred to as “runoff reduction,” has been adopted as a regulatory standard in some parts of the USA, along with new stormwater practice design specifications and computational methods. The approach demands that stormwater design reach beyond sole reliance on engineering, as the new best management practices (BMPs) include site design strategies that incorporate elements of soil science, horticulture, landscape architecture, and, importantly, site planning. These new strategies have certainly been elevated to prominence by virtue of the hydrologic benefits but also by the integration of stormwater management into Clean Water Act permits and Total Maximum Daily Loads (TMDLs) assigned to impaired urban streams and receiving waterbodies. This chapter will outline the evolution of stormwater management regulatory goals and the corresponding design strategies and include examples of how these approaches are changing the structural and nonstructural design of the urban landscape.

**Keywords** Channel protection • Impervious cover • Stormwater • Stormwater practice • Urban infrastructure

## 1 Introduction

Stormwater management has transcended many eras, beginning with an engineering focus on conveyance and shedding water rapidly from the developed landscape. Increasingly, the stormwater field has expanded its scope in terms of treatment objectives – treating the quantity and quality of runoff as well as reducing its volume (regulatory standards) – and in the range of professions and areas of expertise needed to implement successful stormwater projects in urban environments.

The earliest era was driven by urban infrastructure expansion during the industrial revolution, which gave rise to the need for drainage systems to safely remove stormwater to protect lives and infrastructure. Over many years, civil engineers developed hydrologic models and computational cost-benefit tools for predicting maximum rainfall and the scale of drainage infrastructure needed to protect the health, safety, and well-being of the public and infrastructure. The pave and drain design model was very effective at shedding stormwater from the urban environment and efficiently conveying it downstream to stream channels within and below the urban centers.

Over time, it became apparent that an important element of this strategy was being ignored – the receiving stream channel. The network of streams that previously meandered through the urban landscape were recognized as being more valuable and complex than simply a drainage conveyance for large pulses of

stormwater runoff. Peak flow attenuation in the form of stormwater detention basins was designed to minimize channel erosion and out-of-bank flooding.

Starting in the 1980s, a holistic view of the interconnected watershed gave rise to another set of performance goals – stormwater runoff quality. Provisions of the Clean Water Act were proving effective at improving the water quality of the nation’s rivers and streams by addressing pollution associated with industrial discharges and municipal wastewater treatment. However, continued decline of water quality soon cast a light on an almost invisible culprit – stormwater runoff tainted with a wide variety of pollutants flushed from the urban landscape [1]. The increased runoff was delivering more pollutants to the streams than could be assimilated. Acknowledgment of this problem effectively launched the modern multidisciplinary approach to stormwater management.

Though committed to the protection of the public’s health and well-being, civil engineers’ transition through these stormwater epochs has not been easy. Changes in design standards had to navigate through dizzying layers of federal, state, and local regulatory oversight and then be embraced by the land development industry.

This chapter will provide an overview of the history of stormwater practice in the USA as it evolved, with explanations of the engineering and watershed dynamics that informed various design eras. Next, the chapter will explore the relationship between stormwater management and the very fabric of how development sites, neighborhoods, and communities are designed in the first place. The key to this is improving the integration of stormwater and site design and community planning. It is only with this integration that communities can reduce stormwater impacts “by design.” A logical outgrowth of this exploration is an increased focus on stormwater volumes, and how combinations of site planning and various “runoff reduction” practices can help meet ever more stringent regulatory requirements.

An emerging trend in stormwater management is that many disciplines beyond engineering are becoming important pieces of the stormwater design puzzle. In an era where vegetation communities and stream dynamics are as important as engineered conveyance and storage systems, many areas of expertise are required to design, install, and maintain a well-functioning stormwater system. The chapter concludes with an examination of recent regulatory trends, as the regulatory approach becomes more holistic and ambitious in terms of meeting site and watershed objectives for clean water and better communities.

## 2 History of Stormwater Practice

The approach to managing stormwater runoff and the subsequent design of drainage infrastructure have evolved through three significant eras: (1) *pave and drain*, (2) *stream channel and flood protection*, and (3) *natural resource protection*. Each era is described briefly in this section.

## 2.1 The Pave and Drain Era

Historical drainage and infrastructure protection involved a philosophy of intercepting, collecting, and disposing of stormwater runoff as rapidly as possible. The early days of drainage design were largely focused on two systems – the *minor system* and the *major system* [2]. The *minor system*, sometimes referred to as the “conveyance system” consists of curbs, gutters, inlets, pipes, swales, channels, and appurtenant facilities all designed to minimize nuisance, inconvenience, and hazard to persons and property. The *major system* consists of the drainage system of natural channels, streams, floodplains, and, in some cases, large man-made systems (e.g., culverts) that carry excess flow over and above the hydraulic capacity of the various components of the *minor system*.

As this process evolved, the minor system was designed to efficiently capture, contain, and convey the maximum expected peak rate of runoff from larger storms. The adoption of a larger minimum design storm for the minor system is indicative of a failure to recognize the importance or even existence of the major system (natural stream network) and was a response to public safety and economic risks associated with increasing flood hazards in the built environment [3]. However, the preoccupation of engineering the minor system led to even greater cumulative impacts of increased flooding and channel degradation. In many cases, this required construction of large-scale engineered conveyance channels to protect adjacent properties from further damage (Fig. 1).



**Fig. 1** An urban channelized and “hardened” stream (*left*). An eroded stream (with sewer manhole exposed) (*right*) (*Source: US EPA*)



### 2.1.1 The Rational Method

The primary design tool of the pave and drain era was the Rational Method for calculating the amount of runoff needed to be captured and conveyed. Once that number was calculated, hydraulics and fluid mechanics governed design of the drainage system. The most important feature of the Rational Method was its simplicity – having only three terms:

$$Q = CiA \quad (1)$$

Q = peak rate of runoff ( $m^3/s$  or cfs (cubic feet per second))

C = dimensionless runoff coefficient

i = rainfall intensity (measured in mm/hour or inches/hour)

A = contributing drainage area ( $m^2$  or  $ft^2$ )

Simplicity is also a function of having a single runoff coefficient to characterize the hydrologic response of the contributing watershed, i.e., how much of the rainfall becomes runoff. This can be a problem if the designer is trying to determine the runoff from a complex watershed – different subareas consisting of different land covers – impervious cover, lawn, woods, and other surfaces, each having a different hydrologic response. Finally, the product of this simplicity is the calculation of peak discharge – not a runoff hydrograph, or runoff volume, or other time-based measures of the rainfall-runoff relationship. Rather, the Rational Method produces the maximum peak discharge that occurs when the entire drainage area is contributing flow. This was considered to be a perfectly acceptable methodology in the early twentieth century when highway designers popularized the Rational Method use on relatively homogenous watersheds for the design of culverts and drainage systems – a simple formula (no calculators or computers required) to calculate a peak discharge.

The drainage infrastructure of the pave and drain era and the majority of the drainage system infrastructures being designed today are still sized using the Rational Method. However, as the design parameters became more complex through time, hydrologists tried to improve the applicability of the Rational Method to large catchments with heterogeneous land cover, topography, soils, and rainfall characteristics (such as antecedent moisture conditions between storms). The resulting runoff unit hydrograph technique became the standard for the flow attenuation basin designs of the *stream channel and flood protection* era.

## 2.2 Stream Channel and Flood Protection

The next phase of stormwater management expanded the scope of the engineered system by recognizing the interrelated functions of collection and storage of stormwater runoff. As the urbanized landscape was engineered to shed stormwater

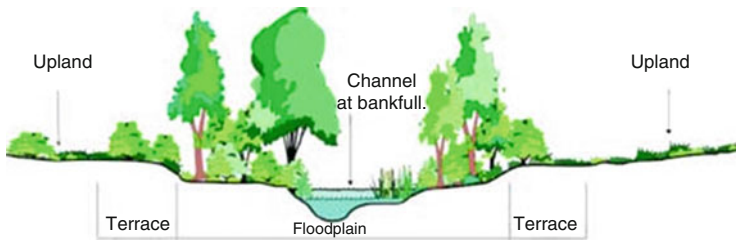


Fig. 2 Typical natural stream cross section with riparian ecosystem [4]

runoff as quickly as possible, small streams became raging rivers within a matter of hours or even minutes of the rainfall as the drainage system quickly and efficiently sent torrents of stormwater into the stream. Stream channels underwent often dramatic changes – widening of the channel banks and down-cutting of the stream bed in order to evolve and accommodate the new watershed conditions.

Stream channels were formed over geologic time by runoff from an undeveloped watershed. Periodic rain events and the runoff characteristics of the watershed – such as land cover, soil types, topography, and other factors – generate runoff, measured in terms of total volume of runoff and the peak rate of runoff ( $\text{m}^3/\text{s}$  or cfs). The stream channel evolves over time until it reaches its hydraulic equilibrium – a flow area (depth and width), floodplain, and supporting riparian zone necessary to carry the base flow, the runoff from frequently occurring storms (bank-full), and the runoff from the large infrequent storms (floodplain) (Fig. 2). Continued variations in the velocity of the natural flow and the transport of sediment balance create a stable “hydraulic geometry.” The natural system achieves a delicate balance based on the hydrologic response of the contributing watershed.

Less than a 10 % increase in impervious cover can change the hydrologic response characteristics of a watershed and impact stream equilibrium, causing erosion and a decline in aquatic health [5]. The symptoms of the changes in hydrologic response include (1) an increase in flow volume, (2) a decrease in lag time (time for runoff from the drainage area to reach a downstream point), and (3) an increase in peak discharge.

The increase in flow volume primarily reflects changes in land use and land cover as the construction of impervious surfaces, e.g., shopping centers, roads and highways, subdivisions, and other developed areas, reduces the infiltration capacity of the landscape and increases total runoff volume. Decrease in lag time is a product of the increase in impervious surfaces and the installation of the efficient drainage network. Impervious surfaces shed runoff more quickly than undeveloped landscape, and the drainage network carries it quickly through the watershed to the receiving stream, resulting in larger and sudden peak surges of runoff. The increase in peak discharge is the result of the combination of increased volume and decreased lag time.

Using Fig. 3 to help visualize the impact of impervious cover, imagine 3 inch (76.2 mm) of rainfall on an undeveloped watershed, generating 0.5 cfs ( $0.014 \text{ m}^3/\text{s}$ )

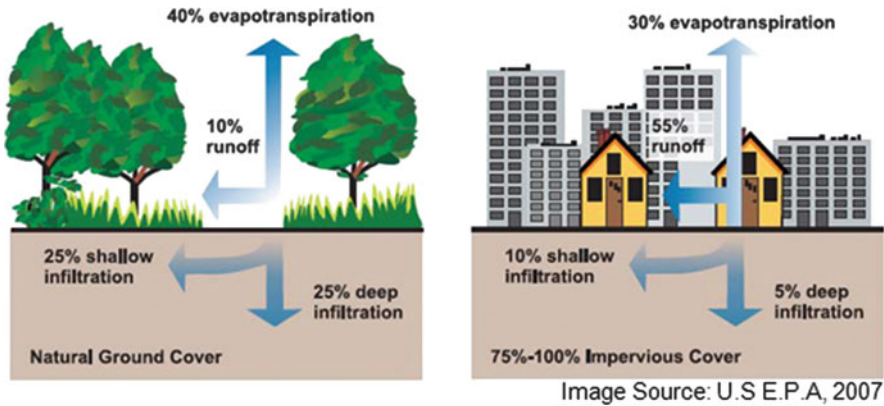


Fig. 3 Developed watersheds generate 7–10 times the amount of runoff compared to undeveloped watershed from the same amount of rainfall [6]

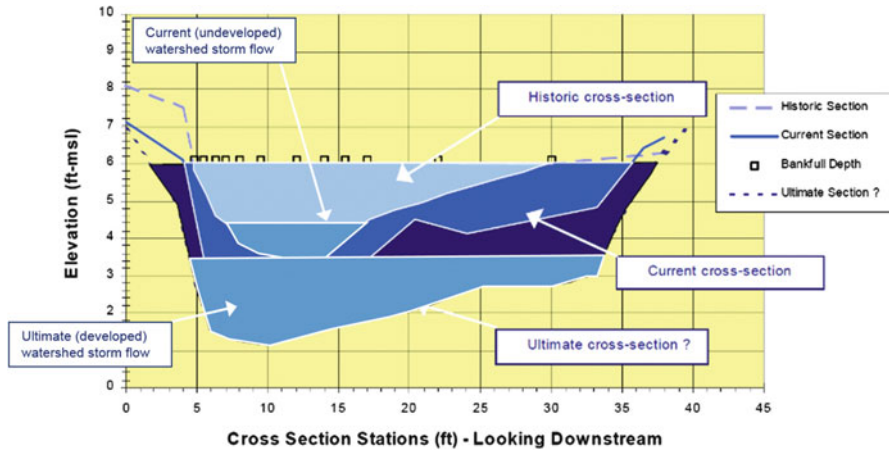
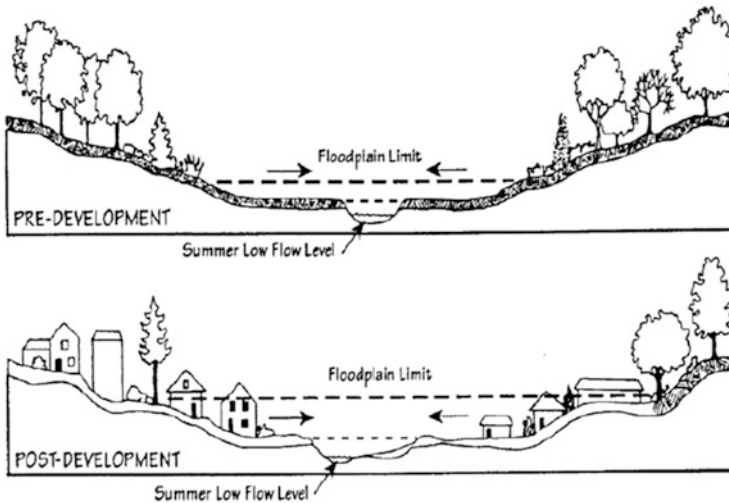


Fig. 4 Representative stream channel cross-section enlargement [7]

per acre of watershed. Now imagine the same watershed covered with a typical urban infrastructure, associated decrease in infiltration and evapotranspiration, and increase in runoff. That same 3 inch (76.2 mm) rainfall generates close to 4.5 cfs (0.13 m<sup>3</sup>/s) per acre of watershed.<sup>1</sup> This generates, on average, an increase of 7–10 times in the volume and peak rate of runoff.

Stream channels are overwhelmed by this new flow regime and begin to rapidly change to establish a new hydraulic geometry and equilibrium. The low-flow portion of the channel must get larger (wider and deeper) to carry the larger and more frequent “bank-full” flow (Fig. 4). Furthermore, as is often the case in

<sup>1</sup> Typical scenario of undeveloped condition consisting of woods and hydrologic soil group B and developed condition consisting of urban/commercial land on the same soil types



**Fig. 5** Changes in floodplain limits and encroaching development lead to property damage during “bank-full” flow conditions [8]

developed areas, the adjacent floodplain has likely been squeezed by development, adding a secondary impact of property damage (Fig. 5). Unfortunately, the hydraulic geometry of this new flow regime is a larger and deeper channel that does not support the aquatic biology of a healthy stream.

Working backward from this new flow regime, it is estimated that the new out-of-bank rainfall-runoff storm event is likely to occur 8–10 times per year rather than the once per year, or once per 2 years, characteristic of an undeveloped watershed. The increased frequency of the channel erosion and out-of-bank flows accelerates channel erosion, stream degradation, and loss of critical stream health functions (Fig. 6).

In developed watersheds, instances of increased channel erosion and flooding are not isolated incidents. These affected areas include stream corridors that wind through new suburban and commercial developments, readily visible to the watershed’s inhabitants (often from their own backyards). This phenomenon compelled a wave of new state and local stormwater management programs focused on detention basins designed to attenuate the peak flow and increase the lag time. Designers would now calculate the detention basin storage volume needed to detain the runoff volume while releasing it at a slower rate.

### 2.2.1 Natural Resource Conservation Service (NRCS) Hydrologic Methods

New stormwater management ordinances expanded on the pave and drain strategy by adding the design element of runoff detention. Designers would now calculate



**Fig. 6** Enlarged stream cross section in response to watershed development (*Source*: second author)

the storage volume needed within a detention basin to capture and detain the runoff volume while releasing it at a slower rate. Therefore, designers needed to know, in addition to the peak rate of runoff, the rate of runoff entering the basin for each time increment and the total volume of runoff for the target design storm. With this revised storage objective, the Natural Resource Conservation Service (NRCS) methods were considered to be more applicable to stormwater management design goals.

NRCS has been developing runoff models for agricultural watersheds since the 1930s with the first fully published methodologies in the 1950s [9]. The NRCS method utilizes a range of watershed hydrologic parameters such as soil types, land cover, land treatment, initial abstraction, time of concentration, and antecedent moisture conditions that allow for modeling of complex watersheds and generating both a peak rate of discharge and a runoff hydrograph.

A runoff hydrograph is a plot of the rate of runoff with respect to time, with the maximum discharge occurring at the peak of the curve (Fig. 7). For stormwater management purposes, another important feature of the hydrograph is that total runoff volume is represented by the area under the curve.

The data required for designing a detention basin is a straightforward task of hydrology and hydraulics. The NRCS methodology for the hydrologic analysis of a watershed was updated and repackaged in 1975 as *Technical Release 55 (TR-55): Urban Hydrology for Small Watersheds*. Updated in 1986, TR-55 presents simplified procedures to calculate storm runoff volume, peak rate of discharge,

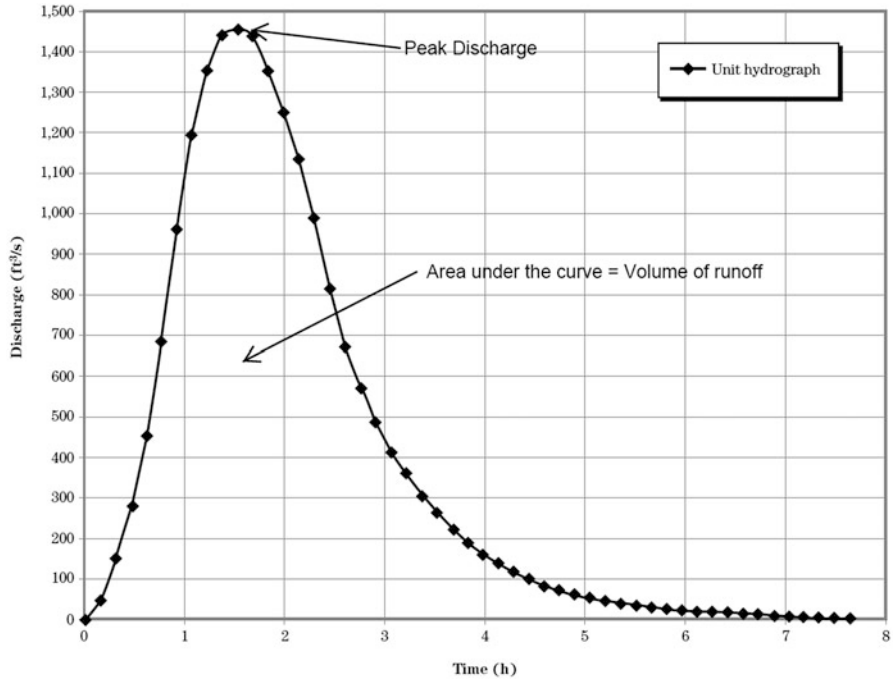


Fig. 7 Example of a unit hydrograph [10]

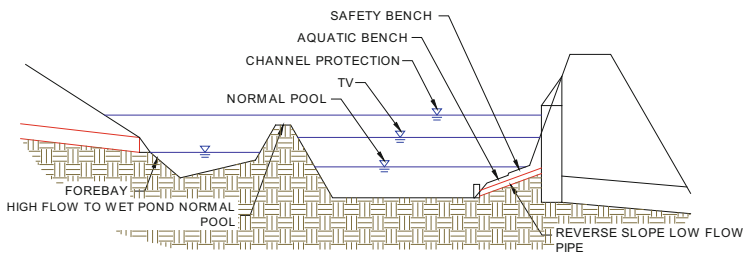


Fig. 8 Image of typical multi-criterion detention basin: storage volume for water quality volume, 2-year and 10-year design storms, and an outlet riser structure [12]

hydrographs, and storage volumes required for the design of detention basins in small urbanizing watersheds [11].

The design of detention basins to reduce the post-developed 2-year peak rate of runoff to the pre-developed peak rate has been applied on most development projects, large and small, for many years. Most local stormwater management programs include detention requirements for channel protection, i.e., detention of the 2-year return interval design storm, and additional requirements for localized flooding control, i.e., detention of the 10-year (or other targeted large) return interval design storm (Fig. 8).

Many jurisdictions, especially those experiencing rapid growth, sought benefits through an economy of scale and preferred a single large detention facility designed to manage the peak runoff from multiple developments, rather than stormwater basins on every development site. This strategy, referred to as a regional stormwater program, often sacrificed the intermediate channels between the developed land and the regional basin as an acceptable trade-off for the reduced total construction costs, long-term maintenance costs, and land costs. Over time, the regulatory agencies responsible for preserving the natural stream channels would begin to deny permits due to the impacts of in-stream construction of embankments and temporary impoundments.

Over a period of years, evidence of channel erosion downstream of these detention basins has given credence to what stream geomorphologists had known all along – the changes in the contributing watershed could not be mitigated by simply attenuating the peak discharge. The hydrologic response characteristics of impervious cover and an improved drainage system generate 7–10 times increase in runoff volume which translates to an increase in the frequency of occurrence of the peak discharge. Furthermore, the flow attenuation provided by multiple detention ponds scattered throughout a watershed can add to the problem by increasing the duration of the peak discharge, thereby also increasing the damaging erosive energy exerting forces on downstream stream networks.

A new approach was needed that recognized the fuller dimensions of the hydrograph – peak rate and volume – and how changes in watershed land use affect the natural stream network (previously identified as the *major system*).

### **2.3 Natural Resource Protection**

In 1983, US Environmental Protection Agency (US EPA) released the results of the Nationwide Urban Runoff Program (NURP). The program's goal was to compile a database and develop analytical methodologies that would allow the examination of the quality characteristics of urban runoff, the extent to which urban runoff is a significant contributor to water quality problems across the nation, and the performance characteristics and the overall effectiveness and utility of management practices for the control of pollutant loads from urban runoff [1].

The report noted that water *quantity* problems are relatively easy to identify and describe, e.g., channel erosion resulting from a tenfold increase in flow and out-of-channel flooding is easy to notice. On the other hand, water *quality* problems often go unnoticed and don't manifest themselves immediately, but rather over a long period of time in which the causes have been embedded into the landscape. Water quality management was becoming a new and important design objective for stormwater management.

A related trend emerged in the late 1990s. Low-Impact Development (LID) gained traction as a design and computational approach to addressing the obvious impacts of urbanization on aquatic systems – a design strategy with the goal of

maintaining or replicating the predevelopment hydrologic regime through the use of a variety of design techniques [13]. LID expanded on the hydrologic functions of storage, infiltration and ground water recharge, as well as the reduction in volume and frequency of discharges through the use of integrated and distributed micro-scale stormwater retention and detention areas.

LID also built on minimization and avoidance strategies of preserving and protecting environmentally sensitive site features such as riparian buffers, wetlands, steep slopes, valuable (mature) trees, flood plains, woodlands, and highly permeable soils, all of which have been incorporated into the EPA stormwater permit lexicon. The LID lexicon became a guiding theoretical principle in many state stormwater programs. Where LID was envisioned as a strategy to influence the fundamental process of urbanization, the *pave and drain* development infrastructure was still being implemented, with a sprinkling of LID on the side.

This critical step in the evolution of stormwater compelled the search for a practical methodology for assessing the applicability and implementation of site design strategies. The first step was an impressive array of new and equally inviting development acronyms: Environmental Site Design (ESD), Green Infrastructure (GI), and Better Site Design (BSD). The next step was to develop the scientific basis and a regulatory framework for codifying the implementation of site design strategies and distributed runoff retention practices for achieving volume reduction goals as a compliance tool. The concept is certainly not new; however, the evolving multidisciplinary design team concept is new, and with a regulatory framework supporting it, progress is being made.

The following sections describe how these new approaches led to a movement to integrate stormwater management with fundamental site design principles and to utilize stormwater (runoff) volume as a unifying theme for computations and design.

### 3 Stormwater, Site Planning, and Land Use

LID and its companion movements illustrated that the best and most direct way to reduce stormwater runoff impacts and volumes is to reduce the amount of stormwater generated in the first place. This process begins with site planning and design, both at the site and community scales. Development projects can be designed to reduce their impact on watersheds when careful efforts are made to conserve natural areas, reduce impervious cover, and better integrate stormwater treatment. By implementing a combination of these approaches, it is possible to reduce the amount of runoff and pollutants generated by a site, a neighborhood, or entire watershed.

The goals of this site and community planning approach include (1) preventing stormwater impacts rather than mitigating them; (2) managing stormwater (quantity and quality) as close to the point of origin as possible and minimizing collection and conveyance; (3) utilizing simple, nonstructural methods for stormwater



management that are lower cost and lower maintenance than structural controls; (4) creating a multifunctional landscape; (5) using hydrology as a framework for site design; and (6) conducting community planning to avoid the proliferation of impervious cover and disturbed land across wide swaths of the community.

Terminology can be confusing with stormwater management concepts: “Low-Impact Development” (LID), “Green Infrastructure,” “Environmental Site Design,” and “Better Site Design” (BSD) have similar and overlapping goals. All of these terms refer to goals of replicating a more natural hydrology at development sites, preserving key natural resources, and treating stormwater close to its source with distributed (and often vegetated) practices. In this chapter, BSD is used to describe these approaches collectively, referring to a group of generally nonstructural and policy-related practices that achieve the aforementioned objectives [14]. This is not to imply that all of these terms have identical meanings and objectives. BSD is simply used here to refer to the general approach of linking stormwater with site planning and design.

BSD is also related to the concept of “Smart Growth.” While BSD refers to *how* development is conducted at the scale of an individual site or neighborhood, smart growth is a concept that operates at a broader, community-wide scale and is more concerned with *where* development takes place. Smart Growth directs a community’s development to designed areas with existing infrastructure (e.g., infill and redevelopment) while avoiding new growth (or sprawl) in the countryside. Smart Growth can be the backbone of a community’s land use strategy and is an important tenet of community planning [15]. Table 1 outlines some of the benefits of using BSD for various stakeholders involved in the land development process.

**Table 1** Benefits of BSD for various stakeholders, as compared to conventional development

Stakeholder	Benefits
Developers	Provides flexibility in design options Allows for more sensible locations for stormwater facilities Facilitates compliance with wetland and other regulations Allows for reduced development costs, especially for stormwater infrastructure
Local government	Improves quality of life for residents Facilitates compliance with wetland and other regulations Assists with compliance of Municipal Separate Stormwater System (MS4) permits and Total Maximum Daily Loads (TMDLs) Increases local property tax revenues due to higher home values
Homeowners	Increases property values Creates more pedestrian-friendly neighborhoods Provides open space for recreation Results in a more attractive landscape Reduces car speed on residential streets Promotes neighborhood designs that provide a sense of community
Environment	Protects sensitive forests, wetlands, and wildlife habitats Protects the quality of local streams and lakes Generates reduced loads of stormwater pollutants Allows more recharge of groundwater supply Helps reduce soil erosion during construction

BSD aims to protect and conserve natural areas, reduce impervious cover, and integrate stormwater management with site design. These principles can provide notable reductions in stormwater runoff rates, volumes, and pollutant loads. Also, they can reduce development costs and increase property values [16–18].

When applied to development design, BSD must be considered very early in the development process, and this has become one of the primary challenges to implementation, as most common land development projects tend to address stormwater and runoff very late in the process – once road and lot footprints have been established. The Smart Growth context is even more challenging, as existing (and often very old and decaying) drainage systems need to be reworked and retrofitted to become more functional for water quality protection.

Furthermore, many communities across the country have found that their own local “development rules” (e.g., subdivision ordinances, zoning ordinances, parking lot and street design standards) have prevented BSD techniques from being applied during the site planning and design process [14]. These communities have found that their codes and ordinances are responsible for the wide streets, expansive parking lots, and large lot subdivisions that are crowding out the very natural resources they are trying to protect. Examples include the minimum parking ratios that many communities require for retail or commercial development and zoning restrictions that limit conservation development designs. Common land use development regulations, codes, and policies influencing the creation of impervious cover (and that should be reviewed for consistency with BSD and Smart Growth goals) include [19]:

- *Zoning ordinance* specifies the type of land uses and intensity of those uses allowed on any given parcel. A zoning ordinance can dictate single-use, low-density zoning, which spreads development out throughout the watershed, creating excess impervious cover.
- *Subdivision codes* or ordinances specify specific development elements for a parcel, e.g., housing footprint minimums, distance from the house to the road, the width of the road, street configuration, open space requirements, and lot size, all of which can lead to excess impervious cover.
- *Street standards or road design guidelines* dictate the width of the road for expected traffic, turning radius, the distance for other roads to connect to each other, and intersection design requirements. Road widths, particularly in new neighborhood developments, tend to be too wide, creating considerable impervious cover.
- *Parking requirements* generally set the minimum, not maximum, number of parking spaces required for retail and office parking. Setting minimums leads to parking lots designed for peak demand periods, which can create acres of unused pavement during the rest of the year.
- *Minimum setback requirements* can spread development out by leading to longer driveways and larger lots. Establishing maximum setback lines for both residential and retail developments brings buildings closer to the street, reducing the impervious cover associated with long driveways, walkways, and parking lots.

- *Site coverage limits* can disperse the development footprint and make each parcel farther from its neighbor, leading to more streets and roads and thereby increasing total impervious cover throughout the watershed.
- *Height limitations* limit the number of floors for any building. Limiting height can spread development out if square footage cannot be met by vertical density.

To aid in the process of evaluating local codes and regulations, Appendix A provides a sample of questions that can be used with the goal of streamlining implementation of BSD. The questions are organized by general BSD categories of community planning, site planning and design, and reducing impervious cover. A more comprehensive analysis of local development regulations, with more concrete, in-depth questions should be conducted with the Codes and Ordinance Worksheet available in the *Better Site Design* manual [14] or a similar “green codes” tool.

Fortunately, communities have tools at their disposal to better integrate BSD and Smart Growth into local codes and policies. Appendix B provides a partial list of regulatory and site design and policy tools and strategies to consider when developing successful and robust local programs to achieve the goals of better growth patterns and fewer stormwater impacts by design.

This section addressed how BSD and other tools can help reduce stormwater impacts by design. However, this is only one step in a multistep process of stormwater design that also includes using a variety of structural and nonstructural practices in combination with site design and planning. The following section integrates the BSD approach with a more comprehensive design strategy with an acute focus on reducing stormwater volume – the issue of runoff reduction.

## **4 Reducing Stormwater Volume: A New Paradigm in Regulation and Design**

Previous sections addressed the concepts of Better Site Design (BSD) and community land use and development strategies that can be used to reduce stormwater impacts by design, as well as the interrelated concept of Low-Impact Development (LID). LID addresses site design issues but provides a more holistic framework for understanding the hydrologic impacts of land development and replicating a more natural hydrologic response. This and the concept of “Green Infrastructure” stormwater practices are defining a new paradigm for stormwater management. A unifying concept of these approaches is using stormwater practices, integrated throughout a site, that help reduce the overall volume of stormwater generated by and leaving the site, along with the attendant pollutant loads and erosive forces for downstream channels.

In 2008, the Center for Watershed Protection (CWP) and the Chesapeake Stormwater Network (CSN) developed a site planning and computational approach, known as the runoff reduction method (RRM), that quantifies runoff (or volume)

reduction from development or redevelopment sites [20]. The practices employed in such a scenario are referred to as runoff reduction practices.

## 4.1 *Runoff Reduction Practices*

This section briefly describes and illustrates a list of practices represented in various stormwater design manuals and specifications [e.g., 21–25].

### 4.1.1 **Vegetated Filter Strips**

Vegetated filter strips are areas that manage runoff from adjacent developed areas by slowing the runoff and allowing sediment and pollutants to settle out, filtering runoff through the vegetation, and infiltrating into the existing or amended soils (Fig. 9). Applicable to small commercial and residential impervious areas, its critical design elements include maximum allowable contributing impervious area, slope, and minimum dimensions.

### 4.1.2 **Sheet Flow to Conservation Area**

Conservation areas are the “natural” alternatives to vegetated filter strips and consist of natural vegetation (e.g., forest, meadow) receiving runoff as sheet flow



**Fig. 9** Vegetated filter strip (*Source*: first author)

from adjacent developed areas (Fig. 10). Often adjacent to streams or natural features, conservation areas should be protected with easements or other legal instruments to ensure that they function as a natural buffer system. As opposed to vegetated filter strips, conservation areas are outside the limits of disturbance and are not graded. Applicable in residential and commercial drainage areas, its critical design elements include maximum allowable contributing drainage area, slope, minimum dimensions, and long-term management of vegetation.

#### 4.1.3 Simple Impervious Surface Disconnection

Simple impervious disconnection is a landscape practice that directs runoff from rooftops and other small areas of impervious surface to adjacent pervious areas as sheet flow (Fig. 11). Such areas are small scale (as compared to filter strips) and intended for residential or small commercial areas. Critical design elements include maximum allowable drainage area, slope, and minimum dimensions.

#### 4.1.4 Impervious Disconnection with Alternative Practices

Impervious disconnection with alternative practices is utilized when there is insufficient room to establish sheet flow or meet other *simple impervious disconnection* criteria (Fig. 12). Alternative practices include soil amendments, residential rain gardens, rainwater harvesting, stormwater planters, and infiltration (covered separately in more detail below). Its effectiveness is based on the same performance



Fig. 10 Sheet flow to conservation area (Source: first author)



**Fig. 11** Simple impervious surface disconnection (*Source: first author*)



**Fig. 12** Impervious disconnection with alternative practice (*Source: second author*)

mechanisms as the individual practices. Critical design elements include the volume and depth of incorporation of soil amendments and design elements of the alternative practice.

### 4.1.5 Bioretention

Bioretention is a landscaped practice that uses plants, mulch, and soil to treat runoff (Fig. 13). The practice is commonly used in parking lot islands and edges and as part of commercial site plans. It can be designed as an infiltration practice or an extended filtration practice (with an underdrain). Critical design elements include surface ponding volume, soil media depth, and underdrain and several design variations.

### 4.1.6 Permeable Pavement

Permeable paving materials include concrete, asphalt, and interlocking pavers that allow runoff to filter through voids into a gravel storage reservoir (Fig. 14). It can be designed as an infiltration practice, an extended filtration practice (with an underdrain and stone sump), or a filtering practice (underdrain without sump). Critical design elements include structural load capacity for traffic, surface slope, and limiting the size of the “external” drainage area (adjacent impervious that “runs onto” the permeable pavement).

### 4.1.7 Grass Swale

Grass swales are designed as conveyance systems with enhanced design features to also provide a level of stormwater treatment and retention (Fig. 15). Designs can be



**Fig. 13** Bioretention (*Source: first author*)



**Fig. 14** Permeable pavement (*Source: second author*)



**Fig. 15** Grass swale (*Source: second author*)

cost effective when used in place of curb and gutter, pipes, and other conveyance systems. Design features include maximum allowable longitudinal slope (or the use of check dams), maximum velocity and depth of flow, large storm conveyance, and trapezoidal cross-section geometry.

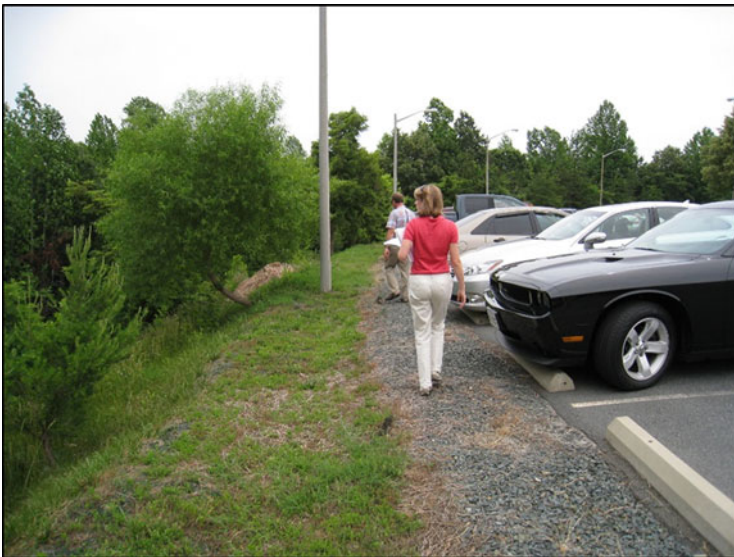


### 4.1.8 Infiltration

Infiltration practices utilize temporary surface or underground storage to allow incoming stormwater runoff to infiltrate into underlying soils (Fig. 16). Runoff first passes through multiple pretreatment mechanisms to trap sediment and organic matter before it reaches the practice. It can be designed as basin, trench, or small-scale practice. Key design features include runoff pretreatment, soil permeability testing, and subsoil conditions – such as groundwater. There are generally strict limitations on use at hot spots or brownfields.

### 4.1.9 Regenerative Stormwater Conveyance (RSC) System

The RSC system is an open-channel conveyance structure that encourages surface flow to transition to shallow groundwater flow through a series of step-pools and riffles and an underlying sand/mulch bed. It can be adapted for moderately steep slopes and used to retrofit existing degraded outfalls or for new development in some cases (Fig. 17). Critical design features include storage volume and peak flow design of riffles and pools, adequate energy dissipation and anchoring system, hydraulic design for large storms, and tying into existing stream channels.



**Fig. 16** Infiltration trench (*Source: first author*)



Fig. 17 Regenerative stormwater conveyance (Source: Center for Watershed Protection)

#### 4.1.10 Rainwater Harvesting

Rainwater harvesting systems (RWH) provide for the capture, storage, and release of rainwater for future beneficial use, either inside or outside the building (Fig. 18). Systems usually capture rooftop runoff. Storage tanks can be a variety of materials and either above ground or underground. RWH is ideal for sites with a beneficial use of the water, such as irrigation, toilet flushing, cooling towers, vehicle washing, etc. Benefits include reducing the use of potable water for irrigation and other outdoor uses, flushing, etc. Design elements include establishing a reliable water budget and pretreatment. Rainwater harvesting is discussed more extensively in chapter “[Modern Rainwater Harvesting Systems: Design, Case Studies, Impacts](#)” of this volume.

#### 4.1.11 Vegetated Roofs

Vegetated roofs are an alternative roof surface that typically consists of waterproofing and drainage materials and an engineered growing media that is designed to support plant growth (Fig. 19). Captures and temporarily stores stormwater within the growing media. Vegetated roofs provide significant life-cycle cost benefits to the building and the environment beyond the stormwater reduction. Vegetated roofs are discussed in more detail in chapter “[Sustainable Water Management in Green Roofs](#)” of this volume.

Ultimately, the choice of practices that a stormwater design professional may use for a particular application depends on meeting local and state standards and requirements to reduce peak flows, pollutant loads, and/or stormwater volumes.



**Fig. 18** Rainwater harvesting (*Source: Center for Watershed Protection*)



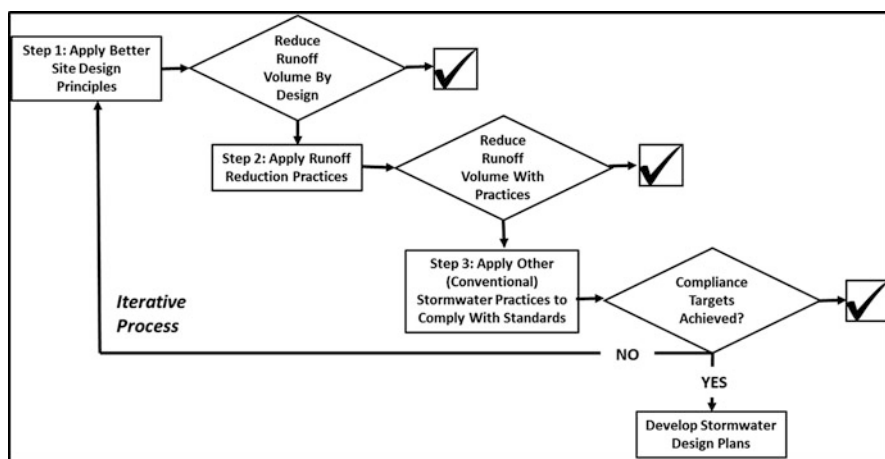
**Fig. 19** Vegetated roof (*Source: West Virginia (USA) Department of Environmental Protection*)

There are many different contexts for compliance, and, as states and local governments update their codes and design standards, the compliance goals change (see discussion in Sect. 2).

## 4.2 Steps for the Runoff Reduction Method (RRM)

The runoff reduction method (RRM) was originally developed for the Commonwealth of Virginia as a compliance framework for the state’s updated stormwater regulations that “encourage” the use of LID [20]. As a compliance tool, the RRM has also been adopted by a number of other states and local governments updating their stormwater design standards and practice specifications, all with variations in methodology and computation procedures [21–25]. This appears to be a growing trend in the USA and some other countries, as stormwater volume (and not just peak rate control) becomes an important metric for a more evolved approach to stormwater management. Figure 20 illustrates the RRM’s conceptual three-step compliance procedure that prioritizes BSD and runoff reduction practices, as described in more detail below.

*Step 1: Apply BSD Practices to Minimize Impervious Cover, Grading, and Loss of Forest Cover* The conceptual three-step RRM process starts with the intended LID goals of minimization and avoidance – avoid impacting the natural features that will continue to provide a hydrologic benefit in the developed landscape and minimize impervious cover and other site features that increase the runoff volume and peak discharge. This step focuses on implementing BSD practices during the early phases of site layout. The goal is to minimize impervious cover and mass grading and maximize retention of forest cover, natural areas, and undisturbed soils (especially those most conducive to landscape-scale infiltration). These strategies reduce stormwater volumes and impacts by design and thus are the most economical and require the least maintenance over time.



**Fig. 20** Conceptual compliance flow path prioritizing Better Site Design and runoff reduction practices (Adapted from Hirschman et al. [20])

*Step 2: Apply Runoff Reduction (RR) Practices* The second step of RRM includes selecting runoff reduction practices that reduce runoff volume through canopy interception, soil infiltration, evaporation, transpiration, rainfall harvesting, engineered infiltration, or extended filtration. In this step, the designer experiments with combinations of the runoff reduction practices (described in previous sections above). In each case, the designer estimates the area to be treated by each practice to incrementally reduce the volume of runoff generated by the site. The designer is encouraged to use practices in series within individual drainage areas (such as rooftop disconnection to a grass swale to a bioretention area) in order to achieve a higher level of runoff reduction. A series of practices strung together in this manner is often referred to as a “treatment train.”

*Step 3: Use Conventional Stormwater Practices as Needed* Ideally, the compliance volume reduction target can be met using only steps 1 and 2. However, situations exist where volumes, detention, or storage targets cannot achieve full compliance. Step 3 involves selecting stormwater practices that, if needed, reduce the pollutant load further via pollutant removal process of settling, filtering, adsorption, and biological uptake. In these situations, the designer can select additional, conventional BMPs – such as sand or organic filters, wet and dry ponds, and stormwater wetlands – to meet the remaining load requirement.

In reality, the process is iterative for most sites. When compliance cannot be achieved on the first attempt, designers can return to prior steps to explore alternative combinations of BSD, runoff reduction practices, and conventional practices to achieve compliance. The runoff reduction performance of the stormwater management practices can also provide credit toward the channel protection requirements by reducing the volume of runoff and in some cases reducing the peak discharge of the targeted design storm as well.

As illustrated in the three-step process, a comprehensive or holistic approach to stormwater design will take advantage of all the multiple tools offered by site design and structural BMPs. Often, the best results can be achieved by using a variety of practices that each work to reduce volumes and pollutant loads using different processes [26]. A designer could choose to put three sand filters in series, one draining to the next. However, since all three practices rely on filtration as the treatment mechanism, the effectiveness of this “treatment train” will diminish with each subsequent practice in the chain.

A better approach would be to use a treatment train consisting of a vegetated swale (relying on biological uptake and infiltration), followed by a filter and then a pond or basin that uses settling as the main treatment mechanism. In this way, a variety of treatment mechanisms are at work to reduce pollutant loads and volumes. Table 2 provides a general overview of the various treatment mechanisms, in addition to runoff reduction, employed by commonly used stormwater practices.

**Table 2** Stormwater pollutant removal processes (Adapted from [23, Table 3.3])

Removal process	Description and pollutants affected	BMPs
Gravitational separation (also settling or sedimentation)	Downward removal of solids denser than water and floatation removal of those lighter than water. Pollutants: sediment, solids (particulates associated with other pollutants such as nutrients and metals), oil (hydrocarbons), BOD, particulate COD	Cisterns, permeable pavement, grass swale, BMPs with ponding component, bioretention, regenerative stormwater conveyance system, filtration, stormwater wetlands, and wet and dry extended detention ponds
Filtering	Straining of pollutants by passing stormwater through a media finer than the target pollutants. Pollutants: solids, pathogens, particulate nutrients, particulate metals, BOD, particulate COD	Filtration, vegetated filter strips, bioretention, permeable pavement, grass swale, regenerative stormwater conveyance system, vegetated roof, stormwater wetlands
Infiltration	Passing stormwater downward through existing soils below the surface grade. Pollutants: volume, solids, pathogens, nutrients, metals, organics, BOD, particulate COD	Infiltration, vegetated filter strips, bioretention, permeable pavement, grass swale, regenerative stormwater conveyance system
Sorption	Includes adsorption and absorption – the physical molecular level attraction of a pollutant to media or soil particles. No chemical change (such as ion exchange) occurs. Pollutants: dissolved phosphorus, metals, and organics	Filtration, vegetated filter strips, bioretention, permeable pavement, grass swale, regenerative stormwater conveyance system, vegetated roof, stormwater wetlands
Biological uptake	Broadly termed transfer of substances from runoff to plants can include evapotranspiration. Pollutants: volume, hydrocarbons, nutrients, metals, organics, BOD, particulate COD	Vegetated filter strips, bioretention, grass swale, vegetated roof, stormwater wetlands
Ion exchange	Molecular exchange of one ion from the soil or filter media with an ion in the stormwater to remove pollutants; the ion from the media passes harmlessly through with the stormwater, while the pollutant remains sequestered in the media. Pollutants: metals	Filtration (depending on the media)
Chemical transformation	Process by which pollutants react with other compounds to change structure and are either harmlessly removed or sequestered. Pollutants: nitrogen (ammonia, nitrate, nitrite), organics, hydrocarbons	Filtration, vegetated filter strips, bioretention, permeable pavement, grass swale, regenerative stormwater conveyance system, vegetated roof, stormwater wetlands

### 4.3 Accounting for Runoff Reduction Capabilities of Various Practices

In order for the RRM to serve as a compliance tool, the runoff volume reduction capabilities for the range of stormwater practices had to be identified and quantified. During the development of the method, a literature search was performed to compile data on the runoff reduction capabilities for different stormwater practices [20]. Runoff reduction data were limited for most practices. However, many recent studies have started documenting runoff reduction performance. Based on the research findings, runoff reduction rates were assigned to various BMPs, as shown in Table 3.

In this context, runoff reduction is defined as the average annual runoff volume reduced through canopy interception, soil infiltration, evaporation, transpiration, rainfall harvesting, engineered infiltration, or extended filtration. This is important because many stormwater metrics are based on a design storm, so the average annual measurement is a bit different, and moderates the variability that would be witnessed seasonally or between different rainfall depths and intensities.

The range of values shown in Table 3 represents the median and 75th percentile runoff reduction rates based on the literature search. Several practices reflected moderate to high capabilities for reducing annual runoff volume. Others – including

**Table 3** Average annual runoff reduction values for various stormwater practices (Adapted from [20])

Best management practice	Average annual runoff reduction <sup>a</sup> (%)
Vegetated filter strip	25–50 %, depending on soils, with A/B soils performing at the upper end
Sheet flow to conservation area	50–75 %, depending on soils, with A/B soils performing at the upper end
Simple impervious surface disconnection	25–50 %, depending on soils, with A/B soils performing at the upper end
Impervious surface disconnection with alternative practices	Variable, based on practice used
Bioretention	40–80 %; practices with underdrains at lower end; those that infiltrate into native soils at upper end
Permeable pavement	45–75 %; practices with underdrains at lower end, infiltrates into native soils at upper end
Grass swale	10–20 %
Infiltration	50–90 %
Regenerative stormwater conveyance	40–80 %, depending on soils, with A/B soils performing at the upper end <sup>b</sup>
Rainwater harvesting	Variable, depends on roof capture area, tank size, and beneficial use of water
Vegetated roof	45–60 %, depends on depth and storage of roof media
Dry extended detention pond	0–15 %

<sup>a</sup>Runoff Reduction expressed as a percent reduction in the annual volume of runoff from rain events up to 1 inch (2.54 cm) [20] based on the practice design meeting up-to-date specifications, such as for Virginia and Washington, DC. Ranges indicate median and 75th percentile values

<sup>b</sup>Runoff reduction assumed to be comparable to bioretention/amended media filter practices

**Table 4** Design variations based on geographic and site conditions

Conditions and challenges	Design considerations
Ultra-urban, redevelopment, disturbed sites (e.g., brownfields): Sites where space for stormwater management is extremely limited and/or where previous contamination may limit excavation or use of soils for infiltration	Infiltration into the existing (disturbed or contaminated) soils is likely restricted. Practices may have to use impermeable liners, be shallow in profile, and tie into a storm drainage system. Permeable pavement, green roofs, bioretention planter boxes, and rainwater harvesting may be good options
Karst: Limestone or dolomite landforms characterized by potentially rapid movement of surface water down through solution channels; higher potential for contamination of wells, springs, and surface water	Large infiltration practices can create sinkholes or possibly contaminate down-gradient water supplies. It is advisable to conduct a pre-design geophysical investigation to locate karst features and use small-scale, distributed practices to not concentrate too much water. Similar practices as listed above may be applicable
Coastal: Flat terrain, potentially high groundwater table, previously ditched and drained for agriculture	Excavation depths may be limited, such as for bioretention with an underdrain system. Shallow, vegetated practices are preferable. Permeable pavement, green roofs, and rainwater harvesting may be good choices, as well as retrofit of drainage ditches into meandering wetlands. Design should consider sea level rise and future conditions
Soils: Clay or tight soils that have inherently low infiltration rates	Many practices – such as bioretention and permeable pavement – can be outfitted with underdrain pipes that will allow the practices to function in marginal soils. Some infiltration is still likely to occur, even with clay or hydrologic soil group C soils

filtering, wet swales, wet ponds, and stormwater wetlands – were found to have a negligible effect on runoff volumes and were not assigned runoff reduction rates.

As the concepts of runoff reduction, LID, and Green Infrastructure began to take hold, many concerns were raised about feasibility, achievability, and affordability in different settings. Many locations were questioning whether these types of practices could be used in places with high groundwater table or depth to bedrock, karst topography, ultra-urban settings, and steep terrain. These legitimate concerns led to some innovations that allowed practice designs to be adapted to various land use and geographic settings, as outlined in Table 4. The table is not exhaustive as to the various challenging settings that one may confront when implementing these types of practices but is meant to be representative.

## 5 Stormwater Management as an Interdisciplinary Field

With the advent of a new set of strategies and design approaches (Better Site Design, Low-Impact Development) and a new suite of runoff reduction practices, the field of stormwater management is in a very dynamic period. Stormwater



management has emerged as a true multidisciplinary profession and is no longer the sole domain of engineers. Numerous university-based stormwater centers are training professionals in a variety of disciplines, including engineering, hydrology, landscape architecture, horticulture, soil science, geomorphology, land use planning, and ecosystem science.

Using bioretention as a typical example, Fig. 21 illustrates the typical construction sequence involved with installation of a bioretention practice. As demonstrated in this figure, many elements to this practice make it more complicated than the basins and ponds of the past. Layout must be fairly precise with regard to excavation depths and how the different layers are assembled. The specification, fabrication, and placement of the special engineered soil media require a high level of quality control. The practice is also characterized by installing a plant community that is not only pleasing aesthetically but that can survive in the unique wet and dry cycles of a bioretention and develop over time as a plant ecosystem. These, and other steps, are necessary for truly successful implementation of the practice.

The interdisciplinary element of modern stormwater management is what makes it both exciting and challenging, as various fields of knowledge must be leveraged



Fig. 21 Typical installation sequence for bioretention (Source: first author)

**Table 5** Disciplines needed for successful design and installation of bioretention

Site assessment to inform design process	<p><i>Site planner or landscape architect</i> determines how the practice will fit into the site plan and avoid ecologically sensitive areas, such as mature tree stands, wetlands, streams and springs, existing vegetation</p> <p><i>Soil scientist</i> determines permeability and infiltration rate of on-site soils at proposed practice location</p> <p><i>Surveyor</i> produces base map and locates utilities, property boundaries, and other features</p>
Design	<p><i>Engineer</i> designs grading, materials, erosion and sediment control, and connection with existing storm sewer system</p> <p><i>Landscape architect, horticulturalist, or landscape designer</i> determines plant communities and species that best replicate local ecosystems and that will blend with the overall site</p> <p><i>Local government stormwater specialist</i> reviews and approves plan</p>
Supply materials	<p><i>Qualified materials' vendor</i> supplies stone, underdrain pipe, specialized bioretention soil media, mulch, erosion control matting, and other materials</p> <p><i>Plant nursery</i> supplies appropriate plant stock, preferably consisting of native species</p> <p><i>Certified laboratory</i> tests bioretention soil media to verify that it meets specifications for particle size and composition, performed as needed</p>
Installation of practice	<p><i>Qualified contractor</i> installs as per the design plans and specifications, as well as avoid compaction and handle materials properly</p> <p><i>Trained (and certified) inspector</i> represents the local government and/or owner to ensure that the practice is built according to the specifications</p> <p><i>Engineer of record and surveyor</i> certifies the practice is constructed according to the plan and to produce a record drawing or as-built plan</p>
Maintenance of the practice	<p><i>Trained (and certified) inspector</i> represents the local government and/or owner to conduct annual or periodic inspections and produce punch list of required actions to maintain practice performance and longevity</p> <p><i>Landscape contractor</i> maintains the plant community, removes invasive plants, and adds mulch, according to a preestablished maintenance plan</p> <p><i>Construction contractor</i> makes periodic more significant repairs involving grading, repairing components, or rebuilding the practice</p>

for projects, often with limited budgets and schedules. The multiple disciplines, identified above, will work on a collaborative basis, integrating ideas, practices, and implementation of BMPs. Many professions and professional societies are rising to the challenge by creating continuing education trainings and special subdisciplines with a stormwater focus.

Continuing with the bioretention example, Table 5 outlines the various facets of practice design, construction, and maintenance and the various disciplines that can

or should bring expertise to the project. Stormwater management has transcended its historical focus, and future success depends on continuing to build this interdisciplinary approach.

## 6 Emerging Forms of Regulatory Integration

The earliest incarnation of US EPA regulation of municipal stormwater management was the Phase I Municipal Separate Stormwater System (MS4) permit program finalized in 1990 [27]. The Phase II program was promulgated in 1999 and was more prescriptive in requiring programmatic goals to address impacts of stormwater, referred to as the six minimum control measures. Table 6 outlines the chief elements and differences between the Phase I and Phase II programs.

As US EPA’s experience in implementing the Clean Water Act evolved, there were opportunities to evaluate the various programs. The Phase I and Phase II MS4 permit programs combined with the industrial activity permits, including construction, were successful in identifying more discharges than US EPA and the state permit programs could handle. And while acknowledging that much progress had been made, US EPA also acknowledged that significant challenges to protecting waterbodies from the impacts of stormwater remained, noting that urban stormwater was the primary source of water quality impairment in 13 % of all rivers and streams, 18 % of all lakes, and 32 % of all estuaries.

To help identify solutions to this challenge, the US EPA requested that the US National Research Council (NRC) review its permitting program and offer suggestions for improvement. The following provides a very brief review of select

**Table 6** US EPA National Pollutant Discharge Elimination System (NPDES) municipal stormwater program [27]

Phase I (finalized in 1990)	Phase II (finalized in 1999)
Regulates medium and large MS4s (defined as areas that serve 100,000 or more people) Ten categories of industrial operations Active construction sites of five acres or more	Regulates small MS4s located in an “urbanized area” as defined by the Bureau of Census Additional MS4s outside of UAs designated by the NPDES permitting authority Active construction activities disturbing between 1 and 5 acres
Requires: MS4s to develop and implement a stormwater management plan (SWMP) to: Find and eliminate illicit discharges Control discharges from its system by addressing runoff from active construction sites, new development and redevelopment, industrial program Construction and industrial stormwater dischargers to develop and implement stormwater pollution prevention plans (SWPPP)	Requires: MS4 SWMP must include six minimum control measures: Public education and outreach Public participation/involvement Illicit discharge detection and elimination Construction site runoff control Post-construction runoff control Pollution prevention/good housekeeping

recommendations from the report: *Urban Stormwater Management in the United States* [28]. The items covered here are those that could or already have influenced the delivery of local stormwater management programs. The report is over 600 pages, and this is in no way a review or summary of the entire report.

## 6.1 *Runoff Volume*

As described previously, the 15–20 years of stormwater management evolution had drifted through several stages before finally settling on the concept of runoff (volume) reduction through site design strategies and site-based stormwater management practices. One of the recommendations (among many) in the NRC report was to focus on targeting runoff volume as part of site development compliance requirements [28].

Emphasis on site design (nonstructural) BMPs that avoid or at least minimize the creation of runoff volume and the introduction of pollutants will reduce the mass pollutant load from developing lands. Emphasis on the runoff reduction BMPs that decrease surface runoff peak flow rates, volumes, and elevated flow durations caused by urbanization will likewise reduce pollutant loads. Expanding on that concept, the report identified benefits in using volume (or flow or impervious cover) as a surrogate measure of stormwater loading. Efforts to reduce the surrogate will automatically achieve reductions in pollutant loading, as well as stream channel erosion and sedimentation that adversely impacts surface water quality.

Establishing these more readily measured surrogate parameters as the regulatory target will help eliminate the technical and expensive challenges of regulating highly variable pollutant loading inputs from complex urban watersheds and individual dischargers. The report noted that these challenges have led to unreliable and ineffective monitoring and self-reporting.

However, the technical and regulatory climate of stormwater management has proven to be a more complicated arena. In January of 2013, a Federal Court in Virginia ruled that the US EPA exceeded its authority in establishing a flow-based total maximum daily load (TMDL) for Accotink Creek in Fairfax, Virginia [29]. The ruling stated that runoff and other “nonpollutants” could not be used as surrogates for pollutants to meet total maximum daily loads. In this case, flow was the surrogate for sediment loading in the stream. The ruling raised several questions since the flow was based on sediment rating curves, which ascertained the flow that could be generated within the watershed while still meeting the creek’s water quality standard.

The technical connection between the flow and the sediment loading may have been secondary to the extreme flow reductions that would have been required by the TMDL. The issues of reducing runoff volume and flows in a highly urbanized watershed are no more challenging than if the TMDL had targeted the sediment directly. Targeting volume or flow or even impervious cover would have provided

more readily available sources to retrofit and established a more direct path toward compliance.

## **6.2 *Stormwater Quality and Quantity***

In 2012, a review of state stormwater programs around the country was conducted for US EPA to identify the impact to states of adopting a volume retention standard as part of a potential national rulemaking process. The review revealed that 18 states had adopted a form of volume reduction or retention [30]. The review also revealed that, since the NPDES stormwater program does not include a quantity or channel protection standard, these strategies were largely absent from the state regulatory programs. In some cases, local watershed initiatives established local requirements that were not captured in the review.

In recognition of the demonstrated negative effects of watershed hydrologic modification on the attainment of beneficial uses, the NRC report recommended that the stormwater program embraces water quantity as a concern along with water quality [28].

### **6.2.1 Receiving Stream Health**

The current local stormwater program regulatory framework includes a presumptive compliance associated with implementing site-specific practices in conjunction with development, along with other strategies of stormwater retrofitting and addressing discharges from municipal and industrial sources. The NRC report recommends that the programmatic implementation goals shift to a broader perspective of achieving a targeted condition in a biological indicator associated with aquatic ecosystem beneficial uses or no net increase in elevated flow duration [28].

### **6.2.2 Watershed-Based Permitting**

The current NPDES permit program consists of a series of independent permits targeted toward different dischargers within the same watershed. Permits for municipal, construction, and industrial permits are implemented in “silos” that are independent of each other. The issuance and expiration dates are often on different schedules, and not all discharges are covered.

The NRC report recommends that a watershed-based approach be adopted to integrate all discharge permitting under the municipal authority. The lead and co-permittees would be responsible for collaborating on identifying the watershed goals and implementation plans for achieving compliance. Most importantly, the watershed approach would incorporate the full range of sources, including municipal storm sewer systems, municipal wastewater collection and treatment systems,

public streets and highways, industrial stormwater wastewater discharges, private residential and commercial property, and construction sites.

## Appendix A

Typical questions for reviewing local regulations for compatibility with Better Site Design (BSD) and planning principles

Community planning	
Community planning, infill and redevelopment, smart growth	Does the community have incentives or other regulatory or non-regulatory means to promote infill and redevelopment in areas already served by infrastructure? In general, is it more or less difficult for developers to build in already developed areas versus greenfields?
Site planning and design	
Natural resources inventory	Is a natural resources inventory required or incentivized as part of the preliminary design? Does the community have a land conservation, open space, or green space plan with which individual development sites can integrate? Are there any incentives to developers or landowners to preserve land in a natural state (density bonuses, conservation easements, or lower property tax rates)?
Conservation of natural features	Is there a stream buffer ordinance in the community that provides for greater buffer requirements than the state minimums? Do the buffer requirements include lakes, freshwater and tidal wetlands, or steep slopes? Do the buffer requirements specify that at least part of the buffer be maintained with undisturbed vegetation? Does the community restrict or discourage development in the full build-out 100-year floodplain? Does the community restrict or discourage building on steep slopes?
Development design	Does the local permitting agency provide pre-application meetings, joint site visits, or technical assistance with site plans to help developers best fit their design concepts to the topography of the site and protect key site resources? Are there development requirements that limit the amount of land that can be cleared in a multiphase project? Does the community allow and/or promote planned unit developments (PUDs) which give the developer or site designer additional flexibility in site design? Are open space or cluster development designs allowed? Are the submittal or review requirements for open space designs greater than those for conventional development?

(continued)

	<p>Are flexible site design criteria (e.g., setbacks, road widths, lot sizes) available for developers who utilize open space or cluster design approaches?</p> <p>Does a minimum percentage of the open space have to be managed in an undisturbed natural condition?</p>
Tree conservation and tree canopy	<p>Does the community have a tree protection ordinance?</p> <p>Is a minimum percentage of a parking lot required to be landscaped and/or planted with trees?</p>
Management of open space, sustainable landscaping	<p>Does the community have enforceable requirements to establish associations that can effectively manage open space?</p> <p>Is there adequate guidance for the managers of open space (e.g., homeowners' associations) on how to select and manage vegetation in a sustainable manner?</p>
Community planning: reducing impervious cover	
Reducing roadway and right-of-way width and length	<p>Do road and street standards promote the most efficient site and street layouts that reduce overall street length?</p> <p>What is the minimum pavement width allowed for streets in low-density residential developments?</p>
Alternative roadway components	<p>What is the minimum radius allowed for cul-de-sacs?</p> <p>Can a landscaped island be created within a cul-de-sac?</p> <p>Are alternative turnarounds such as "hammerheads" allowed on short streets in low-density residential neighborhoods?</p> <p>Can "open-section" roads be utilized under certain conditions as an alternative to curb and gutter?</p>
Reducing paved parking and walking areas	<p>What are the minimum parking ratios for various development types?</p> <p>If mass transit is provided nearby, are parking ratios reduced?</p> <p>What is the minimum parking space size?</p> <p>What percentage of parking spaces are required to have smaller dimensions for compact cars?</p> <p>Is the use of shared parking arrangements promoted?</p> <p>Are there any incentives to developers to provide parking within structured decks or ramps rather than surface parking lots?</p> <p>Are there provisions or incentives for shared driveways, reduced setbacks to allow for shorter driveways, and/or use of permeable materials for driveways?</p> <p>Are sidewalk layouts (both sides vs. one side), widths, and materials gaged by the expected use of the sidewalk?</p>
Reducing building footprints	<p>Does the community provide options for taller buildings and structures which can reduce the overall impervious footprint of a development?</p>

## Appendix B

Regulatory and site design/policy strategies to implement Better Site Design, Smart Growth, and better integration of land use with stormwater management

Adapted from Hirschman and Kosco [19]

---

### Regulatory tools

*Overlay zoning* – a technique to “overlay” more protective standards over land with existing zoning. This procedure can be helpful to stormwater managers who need special protection in a discrete area within the watershed. Examples are drinking water supply watersheds, wellhead protection areas, areas subject to flooding, and watersheds for critical resources, such as wetlands and special recreational areas. The overlay zone typically designates allowable land uses and performance standards (see below)

*Special use permits.* In zoning codes, there are often two lists – allowable uses and uses allowed by special use permit. Stormwater managers might want to explore the use of special use permits to apply BMPs for certain uses (e.g., stormwater hot spots, direct discharges to wetlands)

*Performance standards* – usually associated with particular land use categories and can also be tied to special use permits, overlay zoning, and/or rezoning applications. Examples include minimization of clearing and grading, minimization of creation of new impervious surfaces, tree preservation or canopy targets, protection of riparian buffers, and septic system location and design

*Special stormwater criteria* are specifically tailored to discharges to sensitive receiving waters and likely reside in the stormwater ordinance and/or design manual. Examples include temperature control for trout streams, more aggressive nutrient management for drinking water supplies and wetlands, groundwater protection criteria for wellhead protection areas, special detention criteria for flood-prone areas, and pollution prevention measures for stormwater hot spots. (See Chap. 4 [19] for more detail on special stormwater criteria.)

---

### Site design and policy tools

*Compact development* – seeks to meet a certain level of development intensity on a small footprint. Communities might seek this type of design to support walkability, transit station access, reduced infrastructure costs, or for water resource protection. Compact designs can be used in any development setting from ultra-urban retrofits to rural village centers

*Street design.* Many state departments of transportation are issuing “context-sensitive” alternatives for street design, including narrow streets and multiple transportation modes. For transportation planners, the narrow streets are aimed at slower speeds and neighborhood design models. Stormwater managers thus have overlapping interests in better street design

*Utility planning.* The rational and planned expansion of public water, sewer, and other utilities is critical for both land use planning and stormwater management. Utility extensions will likely encourage future growth at higher densities. Utility extensions should be planned for areas designated for infill, redevelopment, and future growth. On the other hand, utility restrictions should be considered for sensitive watersheds

*Mixed-use development.* Highly separated uses (e.g., retail, schools, housing, and employment centers) are implicated in highly dispersed development. A high degree of automobile-supporting infrastructure, which can be over 50 % of development-related imperviousness, is “built in” because walking and other modes of travel cannot be effectively supported. Bringing the uses closer together can lower the number and length of auto trips or support trip substitution. Less roadway and parking can translate into a lowered overall development footprint

*Infill.* Communities are increasingly interested in targeting development to areas where the surrounding land is already developed and served by public utilities. An example is developing housing surrounding a mall or office park. This “infilling” can satisfy a high degree of development demand in an efficient manner

(continued)



---

*Redevelopment.* One of the strongest watershed strategies is reusing (and improving) vacant or underused sites that are already under impervious cover. This can also work for abandoned sites in rural areas as well. Programs such as downtown revitalization, Main Street programs, and brownfield redevelopment programs support these efforts

---

*Conservation development* is a strategy that can work in various development contexts (e.g., urban, suburban) to coordinate and conserve open space. For stormwater, a particular emphasis may be placed on riparian buffers, forest protection, and open space areas that capture and disperse runoff

---

*Purchase and transfer of development rights (PDR, TDR).* PDR programs purchase development rights from landowners and are particularly targeted to areas or watersheds where rural character and natural resources should be protected. TDR programs set up development rights markets whereby some landowners (in rural or sensitive watersheds) can sell their development rights to landowners in areas where growth, infill, and redevelopment are encouraged

---

*Fee-in-lieu programs for stormwater.* In certain areas, stormwater management goals cannot be met solely with on-site stormwater BMPs. Watershed-based approaches are needed to address issues that extend beyond the site boundary. Examples would be areas with existing flooding or drainage problems, impaired watersheds, and watersheds with streambank erosion problems. In these cases, a fee-in-lieu payment or offset fee can be collected from developers to partially offset full on-site compliance. The local stormwater program then uses the accumulated fees to conduct needed watershed repairs and improvements (See Chap. 4 [19] for more information on watershed-based stormwater management approaches and criteria).

---

## References

1. U.S. Environmental Protection Agency (1983) Results of the nationwide urban runoff program. U.S. Environmental Protection Agency. Water Planning Division, Washington, DC, [http://www3.epa.gov/npdes/pubs/sw\\_nurp\\_vol\\_1\\_finalreport.pdf](http://www3.epa.gov/npdes/pubs/sw_nurp_vol_1_finalreport.pdf)
2. Federal Highway Administration (1979) Design of urban highway drainage FHWA-TS-79-225. Federal Highway Administration, Washington DC
3. Jones DE Jr (1967) Urban hydrology – a redirection, civil engineering. ASCE 37(8): 58–62
4. U.S. Department of Agriculture (2004) Riparian restoration, Ellen Eubanks, Landscape Architect 2300 Recreation, 0423-1201-SDTDC
5. Schueler T, Fraley-McNeal L, Capiella K (2009) Is impervious cover still important? Review of recent research. J Hydrol Eng 14:309–315
6. U.S. Environmental Protection Agency (2003) Protecting water quality from urban runoff, document no. EPA 841-F-03-003. [http://www3.epa.gov/npdes/pubs/nps\\_urban-facts\\_final.pdf](http://www3.epa.gov/npdes/pubs/nps_urban-facts_final.pdf)
7. Center for Watershed Protection (2004) Urban subwatershed restoration manual 4: urban stream repair practices, version 1.0, figure 3 watts branch stream cross-section. Center for Watershed Protection, Ellicott City
8. Chester County, PA Planning Commission (1995) Rural community design guide. Planning Commission, West Chester
9. NRCS (1986) National engineering handbook part 630 hydrology. U.S. Department of Agriculture. <http://www.nrcs.usda.gov/wps/portal/nrcs/detailfull/?cid=stelprdb1043063>
10. U.S. Department of Agriculture Natural Resource Conservation Service (2007) National engineering handbook: Part 630 hydrology; chapter 16, hydrographs. [http://directives.sc.egov.usda.gov/OpenNonWebContent.aspx?content=17755\\_wba](http://directives.sc.egov.usda.gov/OpenNonWebContent.aspx?content=17755_wba)
11. U.S. Department of Agriculture Natural Resource Conservation Service (1986) U.S. Department of Agriculture, Urban hydrology for small watersheds, Technical release 55. <http://www.nrcs.usda.gov/wps/portal/nrcs/detailfull/null/?cid=stelprdb1042925>

12. Virginia Department of Environmental Quality (2011) Virginia stormwater BMP clearing-house, design specification #14, wet pond, version 1.9, figure 14.1. Virginia Department of Environmental Quality. <http://www.vwrrc.vt.edu/swc/NonProprietaryBMPs.html>
13. Prince George's County, Maryland (1999) Low-impact development design strategies: an integrated design approach. Department of Environmental Resources, Programs and Planning Division. <http://water.epa.gov/polwaste/green/upload/lidnatl.pdf>
14. Center for Watershed Protection (1998) Better site design: a handbook for changing development rules in your community. Center for Watershed Protection, Ellicott City
15. U.S. Environmental Protection Agency (2015) Smart growth and economic success: investing in infill development. U.S. Environmental Protection Agency, Washington, DC, <http://www2.epa.gov/sites/production/files/2014-06/documents/developer-infill-paper-508b.pdf>
16. MacMullin E, Reich S (2007) The economics of low impact development: a literature review. ECONorthwest, Eugene
17. Winer-Skonovd R, Hirschman D, Kwon HY, Swann C (2006) Synthesis of existing cost information for LID vs. conventional practices. Center for Watershed Protection, Ellicott City
18. U.S. Environmental Protection Agency (2006) Protecting water resources with higher density development. U.S. Environmental Protection Agency, Washington, DC
19. Hirschman DH, Kosco J (2008) Managing stormwater in your community: a guide for building an effective post-construction program, EPA publication number: 833-R-08-001. Ellicott City: Center for Watershed Protection
20. Hirschman DH, Collins KA, Schueler T (2008) Technical memorandum: the runoff reduction method. Center for Watershed Protection and the Chesapeake Stormwater Network. [http://www.vwrrc.vt.edu/swc/documents/CWP\\_TechMemo\\_VRRM\\_20080418](http://www.vwrrc.vt.edu/swc/documents/CWP_TechMemo_VRRM_20080418)
21. Georgia Department of Natural Resources (2009) Coastal stormwater supplement to the Georgia stormwater management manual, 1st edn. Prepared for: Georgia Department of Natural Resources. Prepared by: Center for Watershed Protection. <http://documents.atlantaregional.com/gastormwater/Georgia-CSS-Final-Apr-09.pdf>
22. Virginia Department of Environmental Quality (2011) Virginia stormwater BMP clearing-house. Virginia Department of Environmental Quality. <http://www.vwrrc.vt.edu/swc/NonProprietaryBMPs.html>
23. West Virginia Department of Environmental Protection (2012) West Virginia stormwater management and design guidance manual. West Virginia Department of Environmental Protection. <http://www.dep.wv.gov/WWE/Programs/stormwater/MS4/Pages/StormwaterManagementDesignandGuidanceManual.aspx>
24. Metropolitan Nashville – Davidson County (2013) Low impact development stormwater management manual
25. District Department of the Environment (2013) Stormwater management guidebook. Prepared for: District Department of the Environment, Watershed Protection Division, District of Columbia. Prepared by: Center for Watershed Protection
26. Boston Water and Sewer Commission (2013) Stormwater best management practices: guidance document. Revised by: Boston Water and Sewer Commission. Prepared by: Geosyntec Consultants
27. 40 CFR 122.26 et seq. Electronic Code of Federal Regulations, U.S. Government Publishing Office
28. National Research Council (2008) Urban stormwater management in the United States: committee on reducing stormwater discharge contributions to water pollution. National Research Council, National Academy of Sciences. [http://www3.epa.gov/npdes/pubs/nrc\\_stormwaterreport.pdf](http://www3.epa.gov/npdes/pubs/nrc_stormwaterreport.pdf)
29. Virginia Department of Transportation vs. U.S. Environmental Protection Agency (2013) Case 1:12-cv-00775-LO-TRJ Document 53. U.S. District Court for the Eastern District of Virginia
30. Center for Watershed Protection (2012) Summary of state stormwater standards. Center for Watershed Protection, Ellicott City

# Stream Restoration in Urban Environments: Concept, Design Principles, and Case Studies of Stream Daylighting

Tracy A. Buchholz, David A. Madary, Dean Bork, and Tamim Younos

## Contents

1	Introduction .....	122
1.1	The History and Legacy of Urban Stormwater Management .....	123
1.2	Green Infrastructure: Twenty-First-Century Alternatives to Nineteenth-Century Problems .....	126
2	Urban Stream Daylighting: Definition and Previous Research .....	127
2.1	Definition .....	127
2.2	Previous Research .....	128
3	Urban Stream Daylighting: Site Selection and Design Outcomes .....	129
3.1	Site Selection .....	129
3.2	Design Outcomes .....	131
4	Stream Channel Design Principles and Construction .....	132
4.1	Watershed Assessment .....	132
4.2	Stream Type Classification .....	133
4.3	Levels of Intervention .....	133
4.4	Channel Design: Process and Components .....	133
4.5	Modeling Verification .....	136
4.6	Monitoring .....	137
4.7	Daylighting Stream Construction Considerations .....	137
5	Case Studies .....	140
5.1	Case Study 1: Indian Creek, West Branch, Philadelphia, Pennsylvania (USA) ....	141
5.2	Case Study 2: Harbor Brook, HUB Redevelopment Site, Meriden, Connecticut (USA) .....	144

---

T.A. Buchholz (✉) • D.A. Madary  
Derck & Edson Associates, LLP, Lititz, PA, USA  
e-mail: [tbuchholz@derckandedson.com](mailto:tbuchholz@derckandedson.com)

D. Bork  
Department of Landscape Architecture, Virginia Tech, Blacksburg, VA, USA

T. Younos  
Green Water-Infrastructure Academy, Washington, DC, USA

5.3 Case Study 3: Little Sugar Creek, Kings Drive and Midtown Reaches, Charlotte, North Carolina (USA) .....	149
5.4 Case Study 4: Westerly Creek, Denver, Colorado (USA) .....	155
6 Conclusions .....	162
6.1 Recommendations for Future Research .....	163
References .....	164

**Abstract** This chapter explores the viability of urban stream daylighting as a stream restoration and green infrastructure technology. The history and impacts of “traditional” methods of managing urban streams by placing them in underground pipes are presented and then challenged by proposing daylighting as an alternative urban stormwater management technique. We explore methods of site selection, stream analysis, and natural stream channel design along with construction considerations in urban environments. We review four case studies in the USA demonstrating the most common daylighted stream channel types, which address some of the specific issues and outcomes of current urban stream daylighting efforts. Compared with case study research in 2006–2007, the majority of daylighting projects are now being utilized to manage stormwater volume in an effort to prevent flooding in downtown business and residential districts. Improvements to water quality and habitat corridors are also important, but are secondary to urban flood control. Our conclusions indicate that urban stream daylighting projects are on the rise across the country, in both urban and rural city centers, but that costs and technical complexity are also on the rise due to heavy urban site constraints and limited available land for establishing more naturalized stream channels.

**Keywords** Alternative stormwater • Green infrastructure • Stream daylighting • Stream restoration • Urban streams

## 1 Introduction

Twenty-first-century America is approaching a turning point in its approach to urban stormwater management. This is precipitated by the deterioration of industrial-era pipes that were built to capture storm runoff and contain natural waterways that interrupted the dense urban development patterns of the nineteenth century. Turn-of-the-century engineering that made rapid land development possible is now failing and creating a host of present-day problems. Cracked and collapsing pipes cause major urban floods as undersized culverts fail to handle the amount of stormwater runoff generated by today’s extensive amounts of impervious surface area. The health of many streams is severely degraded; their

inherent functions of nurturing life, transporting material, and containing floodwaters are disconnected from surrounding natural systems.

Further exacerbating this situation is the fact that many municipalities continue to replace this underground infrastructure system. The act of placing or keeping natural water systems in underground pipes to facilitate land development remains a common practice. Fortunately, current trends in environmental awareness and stewardship are making it possible to imagine and build more sustainable futures for US cities and their invisible rivers, streams, and creeks. Movements toward “green infrastructure,” low-impact development (LID), and environmental best management practices (BMPs) are gaining ground in public debate, policy making, and land planning and design.

Urban stream daylighting is emerging as a viable and multifaceted tool in the green infrastructure arsenal. Removing streams from underground pipes is a biological engineering technology that allows for some degree of restoration of vital stream functions. It also provides meaningful and valuable public green space in urban environments and presents an innovative long-term land use planning tool that permits existing stream systems to evolve simultaneously with their surrounding built contexts. The future character of many urban and suburban neighborhoods can be linked to their historic streams; thus, stream daylighting can become an integral part of planning the future of both natural and human systems.

This chapter investigates the challenges and opportunities that urban stream daylighting can offer a community wishing to restore a buried stream to visibility and vitality. We briefly examine the history of urban stormwater management in order to understand present-day attitudes that affect the treatment of water in urban, suburban, and, increasingly, rural settings. Four current stream daylighting case studies are examined for their effectiveness in restoring urban ecosystems along with community identities.

Daylighting is a deliberately willful act. It seeks to render visible that which is currently invisible by intentionally disrupting the neat patterns of pavement that characterize modern US settlements. It replaces missing pieces of a living system that are easily ignored because they are officially “out of the way,” beneath our feet, and contained safely in a concrete box or pipe. It also endeavors to restore a crucial missing link in the human psyche by restoring water to its rightful place as an essential life-giving force. Revealing buried waterways through stream daylighting is a catalyst not only for design but for reconnecting ourselves to our place in nature.

## ***1.1 The History and Legacy of Urban Stormwater Management***

The link between human settlement and the control of water flow in those settlements dates back at least 4000 years. “Artificial drainage systems were developed as soon as humans attempted to control their environment” [1, p 6]. Sites excavated

in the Indus Valley and in Punjab show that bathrooms and drains were common in Indian cities 4 millennia ago. Even in two millennia B.C., the Greeks and Egyptians had adequate supplies of drinking water for their cities and drained streets, had bathrooms in their houses, and, in Crete, had water flushing arrangements for toilets [2]. Earthenware pipes were used before 1500 B.C. and some pipes in Mesopotamian cities from that era are still in working order.

The development of drainage in London provides a good example of how the specific association between wastewater and stormwater arose. Sewer alignment was “loosely based on the natural network of streams and ditches that preceded them. In a quite unconnected arrangement, bodily waste was generally disposed of into cesspits (under the residence floor), which were periodically emptied. . .it remained illegal until 1815 to connect the overflow from cesspits to the sewers. By 1817, when the population of London exceeded one million, the only solution. . .was to allow cesspit overflow to be connected to the sewers. . .This moved the problem elsewhere – namely, the River Thames. By the 1850s, the river was filthy and stinking and directly implicated in the spread of deadly cholera” [1, p 6]. Thus the connection between rainwater and wastewater began and streams were used for direct disposal of human waste.

In US cities prior to the mid-1800s, small neighborhood grids allowed for management of water with a localized supply and treatment approach that included collecting rainwater in cisterns and designing channels in narrow roads and alleys. However, with the industrial revolution, it was no longer possible to manage city water flow using preindustrial methods. Using urban streams for sewage disposal – and ultimately as the beds of actual sewers – became a standard practice for nineteenth- and twentieth-century engineers.

“By the second half of the 19th century, as epidemic diseases such as typhoid fever killed thousands of Philadelphians, providing proper sewerage and drainage became a subject of great concern, and city engineers began planning the culverting of creeks in advance of development. As early as 1853, City Surveyor Samuel H. Kneass acknowledged that natural watersheds would have to be utilized to provide proper drainage for the city. In the 1880s, when the City engineers drew up their preliminary drainage maps for Philadelphia’s 129 square miles, converting many of the city’s smaller streams into sewers was an integral part of the plan. . .Since it was standard sewage disposal practice to direct branch sewers downhill into the nearest stream, they knew that even pristine surface streams would become polluted once the areas around them were developed. Culverting the streams before they became polluted was seen as a positive step to protect the public health” (Fig. 1) [3, p 2].

As rapid urban expansion took place, concern about pollution in public drinking water led to placing thousands of miles of creeks and rivers into pipes, a leveling process that involved filling in extensive valleys with many tons of fill dirt. Culverting surface water channels was also done in advance of urban expansion



**Fig. 1** Mill Creek Sewer under construction, West Philadelphia, USA ca. 1883 (Image courtesy of Adam Levine, from the Philadelphia Water Department Historical Collection)

to facilitate vehicular traffic. “Building sewers in advance of development also gave engineers freedom in their designs. . . .especially in areas of the city where the rectangular grid system of streets prevailed” [3, p 2]. By placing water systems underground, adequate sewage removal was achieved, large swaths of terrain were conveniently flattened, street grids were laid out, industrial plants were built, and real estate parcels were neatly divided and quickly sold. The public health problems also disappeared – at least for a while [4].

In the twenty-first century, the approach toward developing around (or over) urban streams has not changed considerably. Streams, creeks, and rivers in the way of intended real estate development are frequently targeted for containment, control, and removal – by placing them into pipes and culverts, a practice that is still coined “traditional engineering.” Streams that are not piped but remain in the way of urban and suburban sprawl are particularly threatened. They are frequently damaged by increased sediment loads as well as water volume and velocity entering from development sites, and the damage takes years (even decades) to repair, assuming no further damage occurs (Hession C and Wynn T, 2006, Biological systems engineering department, Virginia Polytechnic Institute and State University, personal communication). “Today, 40 to 50 percent or more of the total land in urban areas is covered by impervious surfaces. . . .This dramatically increases the

rate and volume of storm water runoff and reduces nature's ability to clean our water" [5, p 9]. Aside from stream channel disruption, the development of wetlands, riparian areas, and forest ecosystems "reduces their capacity to perform their natural functions – control floods, trap sediment, and filter out toxins and excess nutrients" [5, p 9].

## ***1.2 Green Infrastructure: Twenty-First-Century Alternatives to Nineteenth-Century Problems***

No single park, no matter how large and how well designed, would provide the citizens with the beneficial influences of nature. . . A connected system of parks and parkways is manifestly far more complete and useful. (Frederick Law Olmsted)

At the turn of the twentieth century, renowned landscape architect Frederick Law Olmsted held a vision of community development that was supported by wildlife biology and landscape ecology experts. "The green infrastructure movement is rooted in studies of the land and the interrelationship of man and nature that began over 150 years ago" [5, p 23]. As early as 1847, public attention was being drawn to the destruction of land by human activities, especially deforestation. By the mid-1800s, proponents such as Olmsted believed that "biologically artificial" urban environments were "detrimental to our mental and physical health" and incorporated parks and greenways into the plans created for cities and towns throughout the country [5].

Nearly 100 years later, the American environmental movement of the 1960s was fueled by public concern about human impacts on the environment. Prevailing attitudes about nature, and who was responsible for protecting it, were being challenged. During this era, the US Environmental Protection Agency was established, and the US Congress passed the Wilderness Act (1964), the Clean Water Act (1973), the Water Pollution Control Act (1972), the Clean Air Act (1970), and the Endangered Species Act (1973) [5].

As a result of these shifts in cultural values, "Over the next two decades, interest grew in the concepts of green infrastructure planning, design and refinement of land conservation practices. Conservation strategies became more holistic and comprehensive, and regulatory approaches gave way to nonregulatory approaches like ecosystem management, sustainable development, and regional planning" [5, p 34]. It was recognized among many professionals that natural areas needed to be connected at larger scales to protect biodiversity and whole ecosystems.

Today, green infrastructure is considered a new approach to land conservation and natural resource management that looks at preservation in conjunction with land development and man-made infrastructure planning. It is a postindustrial conservation approach that considers ecological needs within the context of



human activities. “Green infrastructure provides a framework that can be used to guide future growth and future land development and land conservation decisions to accommodate population growth and protect and preserve community assets and natural resources” [5, p 3].

## **2 Urban Stream Daylighting: Definition and Previous Research**

### ***2.1 Definition***

Urban stream daylighting is one tool in the green infrastructure arsenal. It attempts to address the complex and dynamic hydrologic processes at work in streams that are surrounded by human development and protect streams amidst built contexts. The word itself – “daylighting” – is often unfamiliar to most people, who confuse it with bringing daylight into the interior of a room or building. “The term describes projects that deliberately expose some or all of the flow of a previously covered river, creek, or stormwater drainage” [6, p IV]. Daylighting projects usually remove a stream from an underground pipe and restore the waterway to open air. It is sometimes referred to as an urban stormwater best management practice (BMP) retrofit, because it is a practice usually accomplished in physical surroundings substantially altered by the built environment.

In 1984, the first “official” daylighting project occurred along a section of the Strawberry Creek in a park in Berkeley, California, USA. While other projects reexposed creeks in the 1970s, the Strawberry Creek project is widely considered the archetype of daylighting. Since then daylighting projects have steadily increased across the country (Williams K, 2006, Nelson Byrd Woltz Landscape Architects, personal communication). Over two-dozen stream sections have been pulled out of their underground pipes in the USA since the mid-1980s.

Many perceived and measurable benefits are associated with stream daylighting. It can improve riparian habitat and water quality along newly created stream banks and reduce flood impacts by increasing storage capacity in comparison with culverts (Williams K, 2006, Nelson Byrd Woltz Landscape Architects, personal communication). It can potentially reduce the urban “heat island effect” and reduce greenhouse gases when tree canopy cover is included in the restoration process [7]. Economically, “many communities are finding that the costs associated with ‘daylighting’ a stream can be less than designing new pipes and re-burying the stream” [4, back panel]. Daylighted streams can increase property values and business investment opportunities in stream redevelopment zones, add intrinsically valuable public open space to dense urban communities, and reduce municipal

budgets by replacing deteriorating culverts with open streams that are easier to maintain and repair ([6], Williams K, 2006, Nelson Byrd Woltz Landscape Architects, personal communication).

Stream daylighting offers psychological benefits as well. “In many ways these streams are a metaphor for the way we have ‘buried’ our connection with nature. Daylighting these streams restores not only natural ecological processes, but...it can restore a sense of place and the natural importance of water even in the most urban settings” (Williams K, 2006, Nelson Byrd Woltz Landscape Architects, personal communication). Daylighting asserts the inherent value that water has to the human psyche and the human community – as a provider. Without water it is unlikely that any settled societies would have taken place, as there would have been no reliable source of drinking water, for tending crops and livestock, for travel or the transport of goods.

## ***2.2 Previous Research***

Buchholz [7] conducted an investigation of stream daylighting projects to better understand the impetus, benefits, and outcomes of the practice – and to determine whether or not it is a viable stormwater management alternative to urban drainage pipes. A total of 19 stream daylighting projects, completed from 1984 to 2004 across the USA, were reviewed. The projects represented a wide range of scale, hydrologic and socioeconomic aspects of stream daylighting at various geographic locations in the USA.

Despite apparent contrasts between projects, similarities, found among them, were categorized to facilitate a comparison process. Daylighting was found to be feasible in a variety of situations regardless of geographic location, stream size, hydrologic function, and available funding. Stream daylighting was considered a new phenomenon under the broad umbrella of stream restoration work. Furthermore, trends in project goals revealed five basic catalysts for daylighting a stream: (1) economic development/flood reduction using the natural flood capacity of a new stream to prevent flooding in business districts and facilitate commercial development; (2) the focus of a public park project; (3) ecological restoration – improving habitat structures and water quality and quantity and removing fish barriers to restore aquatic health to a new stream; (4) creating an outdoor classroom/campus amenity, providing an outdoor space to study the effects of new streams and ponds on aquatic species, and creating greenways to schools; and (5) restoring natural stream systems in residential backyards for improved water flow on private property.

### 3 Urban Stream Daylighting: Site Selection and Design Outcomes

Even though there are no definitive rules regarding “when and where” to daylight a length of stream, some essential questions must be addressed before undertaking a daylighting project:

1. What makes a site a good candidate for stream daylighting?
2. What kind of outcome can be reasonably expected on that site?

#### 3.1 Site Selection

The Center for Watershed Protection compiled a list of specific piped stream and site features for evaluating the feasibility of stream daylighting options [8]. Proposed features are described below:

1. Piped stream features
  - (a) Connection with the existing stream network (to lengthen the total corridor)
  - (b) Outfall pipe diameter (short lengths of culverts that disrupt two healthy stream reaches should be investigated)
  - (c) Presence of perennial flow (derived from groundwater)
  - (d) Distance of unobstructed pipe (the greater the distance that a stormwater pipe travels without obstructions, the better)
  - (e) Width of drainage easement (the wider, the better)
  - (f) Depth of overburden (if a pipe is buried deep underground, it may be infeasible to excavate and haul off that much soil and debris)
  - (g) Invert of outfall in relation to connection stream reaches (a drop as small as a few meters between the outfall and the stream may make the new stream gradient too steep and require extensive regrading)
2. Site features
  - (a) Underground utilities – most urban environments include numerous buried utility lines. These facilities are often below grade and not obvious visually. If there are too many or ones that cannot be relocated, they can prevent daylighting from taking place.
  - (b) Presence of contaminated soils – if extensive on the site, they may eliminate daylighting as an option because stream flows should not run through polluted soils.
  - (c) Water table level – if the channel will lose or gain water, this could be a long-term problem worth avoiding by not daylighting or by lining the channel bottom with concrete.

- (d) Significant landscape features – rock outcroppings or stands of mature trees might prevent building a new stream channel on the site.
- (e) Surrounding buildings – the presence of densely built commercial, institutional, or residential structures may impede both the stream design and construction process of a new surface channel; they can also impact what types and sizes of vegetation can grow successfully along the new corridor.
- (f) Urban planning initiative – some urban centers have comprehensive plans that target certain parcels or districts for rehabilitation. Stream daylighting projects can often enhance these areas and may be supported by local community leaders. This support can increase opportunities to secure funding assistance for these projects.

Using these criteria, an example of a site well suited for stream daylighting might be as follows: a short length of stream that is 91.44 m long (300 ft) or less is buried in a pipe less than 0.9144 m (3 ft) underground in uncontaminated soils on a 0.40-ha (1-acre) vacant lot. The pipe itself interrupts an otherwise healthy and stable stream system on either end and no significant elevation change occurs across the length of the site. The existing pipe is old – it was installed in anticipation of development that never occurred – and fails during seasonal rainfall events, flooding portions of the vacant lot and those adjacent to it; sediment and other debris accumulate at the outfall end of the pipe, threatening to disturb the existing stability of the downstream reach. Over time, weeds and small invasive trees have appeared on the site, further degrading it. A stream daylighting project on this type of site can be an excellent opportunity to restore the buried stream segment, protect its downstream reaches, and introduce a new parklike setting that will improve the overall value and attractiveness of the location.

### 3.1.1 Stream Daylighting Restrictions

The Rocky Mountain Institute cautions that “Not every buried waterway is a good candidate for daylighting. There are many technical, economic, institutional, and other reasons many buried waterways should not be unearthed” [6, p 55]. Three scenarios are best avoided – combined sewer systems, contaminated soils on site, and nonsupporting streams.

A combined sewer system is one in which human waste and rainfall runoff flow into the same pipe system for treatment and discharge. Levine [3] stresses that daylighting older combined sewer systems would be prohibitively expensive “. . .since it would mean building a completely separate system of pipes to carry the sewage” [p 1].

With the presence of contaminated soils, any groundwater exchange or bank-topping storm event can interact with polluted soil and degrade water quality further downstream. It is best to cap those soils and leave the stream in its culvert for protection.

Nonsupporting streams are directly related to stream health. The Center for Watershed Protection rates the support capabilities of streams using percentage of impervious surface cover as an indicator. “Non-supporting streams range between 25 and 60 % impervious cover and no longer support their designated uses, as defined by hydrology, channel stability habitat, water quality or biological indicators. . .the primary restoration strategy is often to meet community objectives such as protecting infrastructure, creating a more natural stream corridor and preventing bank erosion” [8, p 5]. As a result, situations involving nonsupporting streams may have to rule out daylighting for ecological purposes altogether.

### 3.2 Design Outcomes

In urban stream daylighting, the physical constraints of a given location yield three common stream design outcomes – artificial streams, channelized streams, and naturalized streams (Fig. 2).

Artificial streams are usually accomplished in highly built urban environment where little space is available for a meandering, shaded stream bed. The resulting daylighted stream needs to be rigidly controlled on all sides, most likely in a lined concrete channel between buildings. This is akin to urban drainage and the new stream resembles the hard control found in bedrock and cascade channels. An “artificial stream” has little ecological function except to contain and control water flow. It is sometimes referred to as “cultural restoration” because it highlights the water’s path without restoring the stream’s basic functions.

Channelized streams are typically found in a suburban setting (or urban area with large vacant parcels). The new stream will likely require stream bank stabilization and some grade controls to prevent erosion and bed incision. The physical setting results in stream designs resembling step-pool, plane-bed, and pool-riffle

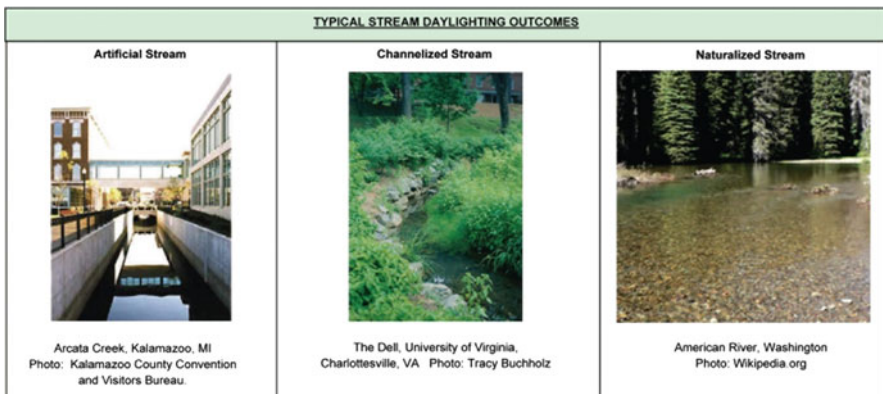


Fig. 2 Typical stream daylighting outcomes (Image credit as noted under each)

streams and accommodates some in-stream features like cross-vanes along with riparian vegetation. These are considered “channelized” or “architectural” streams and offer a higher degree of ecological function than artificial streams – the channel is restored to open air and flowing water, and some aquatic habitat added while still in a partially constrained channel.

Naturalized streams are typically completed in rural settings or on large pieces of property such as school fields and campuses; greater land area exists to reestablish floodplains, wetlands and ponds, sinuous natural stream banks, and wider stretches of riparian plantings and forest buffers. Considered “naturalized streams,” they closely resemble pool-riffle and dune-ripple stream systems and offer the highest degree of ecological function and typically see the largest number of returning fish and insect species within their channels [7].

## **4 Stream Channel Design Principles and Construction**

The emerging field of natural stream channel design addresses the entire stream system when restoring a degraded channel’s natural stability. It focuses on promoting a biologically diverse system through careful redesign of stream banks and beds, planting of riparian vegetation, and monitoring the post-construction results to ensure a restoration project is working. The process of developing a natural stream channel design usually involves the following steps: (1) assessing the watershed, the stream corridor, and the health of its functions, (2) determining the appropriate level of intervention, (3) developing a channel design that accommodates a range of water flows and is the most probably stable form, (4) affirming the channel design via hydraulic modeling software and calculations prior to construction, and (5) monitoring stream stability and ecological function after construction [9].

### **4.1 Watershed Assessment**

A watershed assessment is essential to understanding longer-term, large-scale impacts to the hydrology of a selected watershed over time, as it pertains to a chosen stream reach being considered for restoration. The watershed assessment is of particular importance in designing a channel that can withstand changing inputs in the future. A watershed assessment typically reviews drainage areas and geological information (to determine the physiographic region of a stream reach), amount of impervious cover (watersheds with >15 % cover are considered urban), current land use patterns (plus historical information and assumptions about future conditions), hydrologic patterns (to estimate the 2-, 5-, 10-, 25-, 50-, and 100-year discharges, which is then used to complete flood studies and quantify channel hydraulics), biological and water quality information (fishery management sites and the location of designated impaired streams), and stream type classification

[10]. This assessment helps determine what type of stream channel is likely already in place and its environmental effects.

## ***4.2 Stream Type Classification***

Streams are not static entities; they constantly evolve toward a “state of equilibrium” with their current flow characteristics. When developing a stream channel design, the proposed alterations must be compatible with the stream’s natural tendency to evolve into a particular morphological form or stream classification. A variety of stream classification systems exist, including Schumm, relates straight, meandering, and braided channels to sediment load; Montgomery and Buffington, six classes of channel types; and Rosgen, eight major stream classes +100 individual stream types. Classifying a stream helps determine what type of stream channel that a stream restoration project should achieve [9].

## ***4.3 Levels of Intervention***

Based on the above assessments, the restoration potential of a stream is determined – the goal is to achieve the highest level of restoration reasonably attainable given current (or future) site constraints. One common level of assigning restoration potential – or “levels of intervention” – is with the *Rosgen Priority Levels of Restoring Incised Channels* [10]. *Priority 1* creates a new stable channel that is reconnected to a floodplain; stream bed elevation is usually raised and the former incised channel is filled and converted into a new floodplain structure. *Priority 2* creates a new stable channel connected to a floodplain that is excavated to existing bankfull elevation; the bed of the stream remains at its existing elevation; the stream is given new meanders through the floodplain. *Priority 3* converts a channelized and incised channel into a step-pool channel while keeping existing alignment intact; bankfull benches are created at current bankfull elevations to offer limited floodplain connectivity; in-stream structures are used to slow velocity and force along stream banks and to create the step-pool forms. *Priority 4* stabilizes the channel in place using in-stream structures and bioengineering to decrease stream bed and stream bank erosion, typically used in highly constrained environments, and generally considered only as stabilization, not restoration.

## ***4.4 Channel Design: Process and Components***

Once the watershed assessment, stream classification, and level of intervention are determined, the process of data collection can take place, which will allow preliminary and final stream channel design to take place.

#### 4.4.1 Process

According to the Alliance for the Chesapeake Bay, the only way to create “a sound design is to quantitatively evaluate the principal morphological features of a stream type. . .that is natural or stable (the reference reach) and restore the natural combination of dimension and form. . .to the impaired channel” [9, p 4–1].

The Alliance for the Chesapeake Bay lists the key data collection steps as:

1. Gather project site information.
  - Identify bankfull.
  - Collect data on the dimension, pattern, profile, and bed materials on the selected stream reach.
  - Determine stream type based on the above.
  - Fulfill any other permit-related requirements.
2. Assemble reference reach information.
  - Collect data for the reference reach dimension, pattern, profile, and bed materials.
  - Determine stream type for the reference reach.
  - Convert morphological measurements into dimensionless ratios that will become design values scaled to the selected project area. These will be used in determining proposed width, depth, curvature, cross-sectional areas of riffles and pools, and other channel properties.
3. Gage site information.
  - Field observations for bankfull discharge must be calibrated against known stream flow data. The United States Geological Survey (USGS) gage calibration procedure is the recommended method, using either a gage in the project site or several gages in nearby watersheds that are representative of the site and are in the same hydro-physiographic region.
4. Regional curve information
  - Regional curves are used to validate field observations of bankfull discharge and to assist in determining bankfull discharge in highly unstable systems where field evidence is difficult to detect. Regional curves for the same ecoregion must be used to evaluate the selected project site and stream reach [9, pp 4–2–4–4].

Once all data collection steps are complete, designs for the cross section, planform, and profile of the project reach can be developed. The design will then be checked against traditional modeling analysis programs such as HEC-RAS to confirm the proposed channel will handle different flow conditions [9]. “Field verification provides final design dimensions... and sediment transport capability [of the constructed stream]” [9, p 6–1].



Additionally, identifying “bankfull” discharge is critical to the successful reestablishment of a stream channel’s healthy, long-term form and function. “Bankfull discharge is the stream flow at which channel maintenance is most effective [it is] the discharge that fills a stable alluvial channel to the elevation of the active floodplain....Bankfull discharge is key to stream classification. From bankfull, one can then determine stream type, which can then be used to characterize stream channel cross sections, profile and plan geometry” [9, p 4–5]. Because bankfull is used as the basis for measuring several physical features of a stream channel (width/depth ratio, cross section, etc.), it is imperative to correctly identify the bankfull stage when designing restoration interventions. Furthermore, “It is important that channels not be sized to carry flows greater than bankfull because this may result in channel erosion and/or bed aggradation of sediment” [10, p 7].

#### 4.4.2 Components

The data collection process helps establish hydraulic geometry patterns necessary for constructing a stable stream channel that can adapt to variable flow conditions over time. However, additional physical components help to achieve and maintain the overall channel alignment and depth of the restored channel. Three primary physical components used to accomplish this are (a) constructed in-stream structures, (b) floodplain connections, and (c) vegetation.

In the case of streams located in highly urbanized (or increasingly suburbanized) watersheds or for streams suffering from extensive stream bank failure, both natural and “unnatural” (aka hard engineering) in-stream features are often needed. These include channel “armoring” materials such as large boulders, riprap, and cobbles along stream beds and tops and bottoms of slopes; specialized vegetation such as biologists and anchored, pre-planted coir mats placed on stream banks and in floodplains; and in-stream structures such as J-hook vanes, cross-vanes, and step pools to deflect stream flow away from susceptible banks while facilitating normal sediment deposition [10].

Stream bank and in-stream structures work to support the new channel design by reducing stream velocity, thereby easing the rate of sediment erosion along banks and beds. This in turn helps to keep the channel form stable. Step pools and pool-riffle locations further minimize water velocity while providing much-needed aquatic habitat. “Pools are important for the fish, and riffles are important for the insects. The macro-invertebrates hang out in the riffles because there is more food flowing past them. And the fish hang out in the pools waiting to eat the insects” [11, p 19].

Outside of the stream channel but equally important, natural stream channel design seeks to reconnect or restore a stream reach to its historic – or proposed – floodplain area. The importance of floodplains cannot be overstated: they are a key ingredient for a stable stream because they slow water velocity and allow excess sediment to be deposited outside the channel. “Urban streams are typically cut off from their natural floodplains, which have been paved over and developed....

Unearthing culverts from the ground can help reduce erosion and increase a stream's hydraulic capacity by recreating a vegetated floodplain" [11, p 18].

One final but critical component of natural stream channel design is careful vegetation design. "Vegetation is key to holding a natural channel together" [11, p 18]. Every stream restoration project needs to have a vegetation design tailored specifically to the needs of the project. Vegetation designs should include both temporary and permanent planting plans. "The temporary planting plan is used for erosion control because it quickly establishes an herbaceous cover....The permanent vegetation plan should include native grasses, shrubs and trees...and should be shown in zones, such as along the streambank, floodplains and terraces" [10, p 31]. The planting zone inside the active, restored stream bank offers a special opportunity to use specific plant material and installation methods known as "bioengineering." Examples of this include the use of erosion control matting, live stakes of small trees and shrubs planted directly into stream bank soil, brush mattresses, vegetated coir logs (biologs), and fascines [10].

The use of pre-seeded and/or pre-planted biologs and matting allows for faster plant establishment, which leads to faster erosion control and habitat creation. Planting appropriate native species in and near the stream, its floodplain, and associated wetlands helps to stabilize the soils, filter nutrients and pollutants, and capture sediment. Native species are preferred because they have already evolved over a very long period of time to withstand climate and hydrologic extremes, as well as competition from other native plants. They are generally less disease-prone than nonnatives, are usually noninvasive (although not all native species are docile), and once established need little to no additional maintenance inputs.

#### **4.5 *Modeling Verification***

To create a final design concept, the last step of the design process involves verifying all data in the field and checking it against traditional equations and computer analysis methods. Modeling software such as HEC-RAS can be used to review a variety of conditions that may become present in the new stream channel. HEC-RAS was developed by the US Army Corps of Engineers (USACE) to analyze rivers and streams, to determine if a proposed channel can handle varying flow conditions. Additional hydrology models and equations such as TR-20 and PSU-4 can also be used to estimate the bankfull discharge and dimension [9].

Experts caution against relying exclusively on software modeling for developing the conceptual design; their recommendation is to use field-collected data instead. "Experience shows that accurate field observations of channel characteristics are required to accurately calibrate and corroborate modeling output" [9, p 4-4].

## **4.6 *Monitoring***

Monitoring is conducted to measure the success of natural stream channel design [9]: (1) to meet permit conditions and measure the success of a project's specific objectives and (2) to measure the performance of natural stream channel designs over the long term. The three main objectives of natural stream channel design are sediment transport, habitat restoration, and bank and channel stabilization [9]. Therefore, monitoring design should consider each of these three objectives.

A post-construction stream channel will likely adjust itself, hopefully, in a positive direction. "Monitoring for at least 5 years after construction is recommended to provide time for the stream channel to become more fully established" [9, p 9–1]. Monitoring ideally should take place twice a year for the first 1–2 years, followed by once a year until the 5-year mark. Following this schedule, any emerging problems can be remedied fairly soon after construction is complete.

## **4.7 *Daylighting Stream Construction Considerations***

Once the watershed and stream assessments are done and the design and modeling phases are complete, before construction begins (especially on an urban site), some important aspects need to be addressed. Urban construction projects in general are full of pitfalls, and urban stream daylighting is at even greater risk for potential problems and delays.

### **4.7.1 *Approvals and Permitting***

The permitting and approval process can be time consuming depending on site conditions. State and federal environmental permitting can sometimes take a year or longer to achieve. Fortunately, most local municipalities and agencies look favorably upon efforts to naturalize stream corridors, which may help facilitate the approval process. Examples of approvals and permits that must be obtained prior to construction include local municipal storm drainage review and approval and construction permits and county/state/federal environmental permitting for (1) storm drainage discharge, (2) erosion and sedimentation control, and (3) encroachment when a project impacts an area that is classified as a wetland or streams.

#### **4.7.2 Right of Access: Temporary and Permanent**

Depending on the scope of the project, temporary and permanent access through private or municipal property may be required for construction and for long-term ownership of a stream, its continued function, and maintenance. Generally rights of access require legal agreements with the property owner, when an affected owner is not the entity pursuing the project. Several key rights of access include temporary construction easement, permanent easement, permanent drainage easement, and property acquisition. Temporary construction easement is the least cumbersome right of access – needed only to allow access for construction – and, generally, does not require financial consideration other than restoration of the affected area. Permanent easement covers long-term access to inspect, maintain, or replace facilities and, generally, requires an agreement (which also describes responsibility for long-term maintenance) and form of financial compensation to an affected owner for the impact on and use of their land. Permanent drainage easement is similar to the permanent easement, but with the added complication that the easement allows permanent drainage facilities (i.e., the stream) and may require that the owner offering the easement be “held harmless” from any future issues resulting from drainage such as flooding or erosion. Property acquisition involves actually purchasing a portion of another property for a stream restoration.

#### **4.7.3 Environmental History**

Many urban sites have long histories of varied uses. Past uses may hide hidden subsurface environmental contamination issues. Some locations are classified by state agencies as actual brownfield sites (environmentally distressed) based on known hazards. Others may contain unknown contaminants. Examples of potential contaminants in urban areas include items such as buried fuel tanks and piping, asbestos, metals, oils, and other buried debris. Similarly, there may be issues with contaminated groundwater. Depending on the location of a desired stream segment, a “Phase I Environmental Site Assessment” report may be required prior to commencing stream design plans. This report will identify potential environmental issues, how they would be impacted by the proposed stream modifications, and how these issues may be addressed through regulatory agencies and environmental remediation.

#### **4.7.4 Potential Impacts on Utility Systems**

As mentioned in Sect. 3.1, many urban environments include buried utility lines such as sanitary sewers, water and gas distribution systems, electrical and communications lines, steam distribution systems, oil storage and piping, and fiber optics. Depending on a stream’s location, existing buried utilities may need to be relocated

to daylight a section of stream. In addition, these utility systems may be owned by utility companies, within right of ways and easements, even when located on municipal or private property. A thorough site survey, including utility and easement research by a professional surveyor, is necessary to determine potential utility impacts. Even if utilities do not need to be relocated, the construction contractor is still required to contact the region's utility coordination agency prior to initial excavation work to have all known underground utilities marked in the field. No site excavation work can take place without this step.

#### **4.7.5 Erosion and Sediment Control**

All construction projects aim to minimize secondary erosion caused by site work activities. In urban stream daylighting situations, this translates to keeping the stream inside its culvert during construction to prevent it from flowing through large areas of newly loosened soil and debris and limiting the amount of time that construction equipment remains inside the stream corridor and floodplain areas. To reduce erosion and sediment problems during channel building, *Natural Stream Channel Design Guidelines* [9] suggest conducting all work from the stream bank where possible, adding temporary erosion blankets on loose soils, especially along meanders, and stabilizing all disturbed areas at the exact same time as restoration activities are taking place. All experts recommend conducting pre- and post-construction water sampling to test for increases in turbidity and bank erosion.

#### **4.7.6 Demolition and Hauling**

New construction projects in built urban environments typically require the removal of existing features such as roads, sidewalks, parking lots, bridges, railroad tracks, buildings, signage, some utilities, and even existing vegetation. The demolition process can be further complicated by the discovery of hazardous materials in the form of contaminated soils (i.e., brownfields) as well as chemicals such as creosote (treated lumber), lead, and asbestos inside older buildings. Special permits and protective measures are required for proper removal and disposal of contaminated material and to keep site workers safe from chemical exposure.

#### **4.7.7 Overall Site Design**

Urban stream daylighting projects are frequently integrated as part of larger initiatives to build public parks, recreational greenway trails, habitat corridors, and new pedestrian and vehicular bridges. These site designs have features of their own that require construction, i.e., plazas, fountains, amphitheater seating, walking/jogging trails, fencing, lighting, site furnishings, and vegetation. Installation should be closely coordinated with stream channel construction, to minimize unnecessary

overlap (i.e., demolition and grading activities) and to prevent additional secondary erosion from entering the system.

## 5 Case Studies

In this section, four unique case studies of recent urban stream daylighting projects are described. General characteristics of each case study are presented in Table 1.

**Table 1** Case study characteristics

	Case study 1	Case study 2	Case study 3	Case study 4
Location and brief site description	Indian Creek, West Branch, Philadelphia, Pennsylvania (USA) (Morris Park)	Harbor Brook, Meriden, Connecticut (USA) (abandoned urban commercial site)	Little Sugar Creek, Charlotte, North Carolina (USA) (commercial districts)	Westerly Creek, Denver, Colorado (USA) (30.35-ha (75-acre) abandoned Stapleton International Airport)
Restoration period	2013–2014	2014–2015	2006–2007 (design); 2008–2010 (construction)	2002–2004 (Stapleton International Airport); additional phases up to 2015 (ongoing)
Stream condition	Stream contained in $1.83 \times 1.83$ m (6 ft $\times$ 6 ft) concrete culvert for over 100 years	Source of repeated, major urban flooding through a brown-field site	Stream meanders 30.58 km (19 miles) through urban and commercial districts	Stream buried in concrete culvert for nearly 40 years, approx. 9.14 m (30 ft) below the airport tarmac
Length of stream channel daylighted	396.24-m (1300-ft) reconfigured stream channel + 228.6-m (750-ft) new channel	518.16 m (1700 ft)	685.80 m (2250 ft) of concrete cap removed + 174.65 m <sup>2</sup> (1880 ft <sup>2</sup> ) of parking lot surface cover removed + 1810.51 m (5940 ft) of stream restored	1219.2 m (4000 ft) of culvert removed and 24,352.49 m <sup>3</sup> (860,000 ft <sup>3</sup> ) of contaminated soil excavated

(continued)

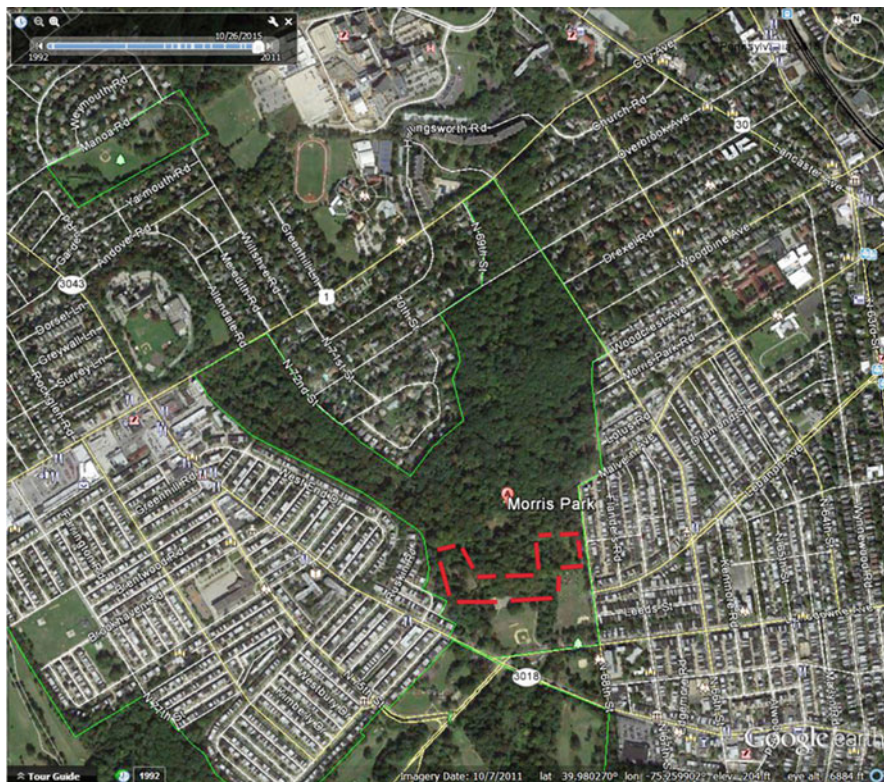
**Table 1** (continued)

	Case study 1	Case study 2	Case study 3	Case study 4
Stream design type	Naturalized stream with some armoring	Naturalized channel with armored bed and banks	Channelized stream with armored banks	Channelized stream in some parts, architectural stream near outfall points
Cost	\$4.5 million USD	\$8.5 million USD (estimated); \$13.5 million USD (actual)	\$1.35 million USD (excludes costs associated with property acquisition and greenway trail construction)	\$15.6 million USD total
Reason for project selection	Headwater stream feeding the Cobbs Creek watershed; Philadelphia’s first daylighting project	Brownfield site targeted for economic redevelopment via stream and floodplain restoration	Part of a larger, multi-phased urban stream corridor restoration effort designed to improve water quality in the stream along with expanded community recreational opportunities	Airport and brownfield redevelopment site focused on sustainable, adaptive mixed-use development; high priority given to habitat restoration, water quality, native vegetation, and passive recreation

## 5.1 Case Study 1: Indian Creek, West Branch, Philadelphia, Pennsylvania (USA)

### 5.1.1 Context

Indian Creek is a second-order tributary of Cobbs Creek in the Darby–Cobbs Creek watershed which drains approximately 199.42 km<sup>2</sup> (77 mi<sup>2</sup>) in and around the greater Philadelphia, Pennsylvania (USA), area [12]. Its urban drainage area includes heavily developed parts of Montgomery County and western Philadelphia. After receiving runoff from two separate watersheds, the East and West Branches of Indian Creek converge in Philadelphia’s Morris Park, where their confluence flows underground in pipes beneath the park. The combined Indian Creek reemerges south of a large public golf course in a very dense urban neighborhood and then meets Darby Creek, which flows into the Delaware River (Fig. 3) [13].



**Fig. 3** Indian Creek, Morris Park, Philadelphia, Pennsylvania (USA) (Source: Unknown 2011, as displayed in Google Earth™)

### 5.1.2 History of Indian Creek

Philadelphia once had 455.44 km (283 miles) of streams, but now all but 189.90 km (118 miles) are buried. The West Branch of Indian Creek was capped in 1928 to make room for suburban homes that were never built [14] and one of many streams integrated into the city's sewer network. As a result, current combined sewage outflow releases excess runoff water and sewage into the West Branch of Indian Creek about 24 times every year.

“According to the water department’s Green City, Clean Waters website, 60 percent of the city now has sewers that carry both storm water runoff and sewage – known as combined sewer systems. In a combined sewer system, both storm water and sewage go to the water treatment plant. But in hard rains, the capacity of the pipes is overwhelmed, and to help prevent flooding of streets and homes the city releases some of the untreated rainwater and sewage into outflow pipes, which lead directly to rivers and streams” [15, p 1].



### 5.1.3 Project Details

To alleviate the sewage overflow problems and frequency in Indian Creek, the Philadelphia Water Department (PWD), US Army Corps of Engineers (USACE), and Philadelphia Parks and Recreation teamed up to daylight the West Branch of Indian Creek (Fig. 4). The new channel, shifted from its historic path, completely bypasses the combined sewer system and connects the respective flows of both stream branches [15]. Large stone boulders (aka riprap) were positioned on lower portions of the stream bank to prevent erosion at the new confluence of the East and West Branches. Its naturalized stream banks were planted with native vegetation to help reduce erosion and provide better habitat [15].

While the project removed the stream from the box culvert, it closed the culvert only at one end. The redesigned culvert will serve as a  $681.37\text{-m}^3$  (180,000-gallon) stormwater storage tank [15]. “The water department is using other means to combat the sewer overflow problem, all directed at keeping water from entering the system, or slowing it. These include stream bank restorations along the sections of Indian Creek that were already above ground, the creation of wetlands and rain gardens, the planting of street trees, the use of non-porous pavement, and even encouraging residents to save rain water in rain barrels and use it to water plants” [15, p 2].

Stream daylighting and construction took just over 12 months to complete [14]. The congressionally funded project is part of the city’s *Green City, Clean Waters* program.



**Fig. 4** West Branch of Indian Creek before daylighting, May 29, 2007 (Image courtesy of Rick Howley, Environmental Engineer, Philadelphia Water Department, Philadelphia, Pennsylvania (USA))



**Fig. 5** West Branch of Indian Creek after daylighting, August 22, 2014 (Image courtesy of Rick Howley, Environmental Engineer, Philadelphia Water Department, Philadelphia, Pennsylvania (USA))

#### **5.1.4 Outcome**

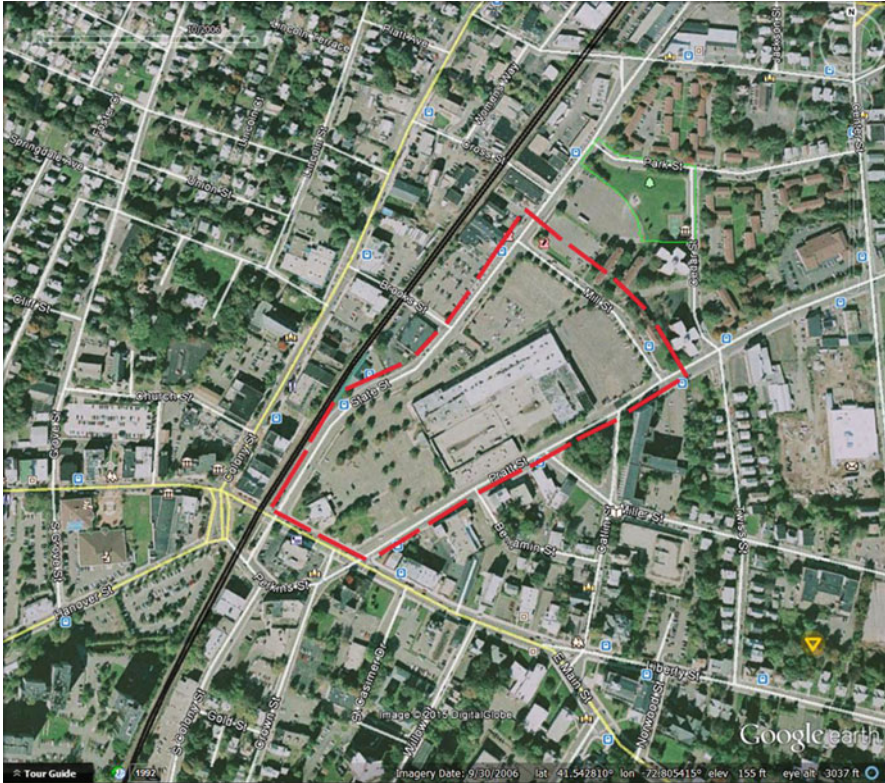
This is the Philadelphia Water Department’s first creek daylighting project. While the city hopes others will be done, that’s impossible for the vast majority of the buried streams; they lie deep beneath buildings as roads, and there’s no room for a waterway in a developed neighborhood. Through this new and reconfigured stream, Indian Creek now flows freely, resulting in stream habitat improvement and site restoration (Fig. 5).

“In total, the project is expected to reduce Combined Sewer Overflows (CSOs) from 24 to three annually and reduce the discharge volume from 10,977.69 m<sup>3</sup> (2.9 million gallons) to 4,542.49 m<sup>3</sup> (1.2 million gallons) per year” [14, p 1]. As a result of these efforts, an estimated 6435.20 m<sup>3</sup> (1.7 million gallons) of stormwater will be kept out of local waterways, reducing one of the largest sources of water pollution in Cobbs Creek watershed [16].

## **5.2 Case Study 2: Harbor Brook, HUB Redevelopment Site, Meriden, Connecticut (USA)**

### **5.2.1 Context**

The City of Meriden, Connecticut (USA), is home to the Harbor Brook sub-watershed region, which covers 31.86 km<sup>2</sup> (12.3 mi<sup>2</sup>), approx. 50 % of



**Fig. 6** Harbor Brook, HUB redevelopment site, Meriden, Connecticut (USA) (Source: Sanborn 2006, as displayed in Google Earth™)

Meriden's total land area. The center of the city sits at a topographical low point ringed by basalt ridges. Through these ridges runs Harbor Brook, winding its way through the heart of the city, including an abandoned industrial site called "the HUB" (Fig. 6). Within the HUB site itself, Harbor Brook runs 5.6 km (3.5 mi) between Baldwin and Hanover Ponds, ultimately draining into the Quinnipiac River [17].

"The HUB site was initially developed as a manufacturing zone to take advantage of the nearby rail line and Harbor Brook as a power source...[the site] historically served as a center of industrial and commercial activity in Meriden's downtown" [17, p 4]. As a result, over 300 residential and commercial properties sat within the existing Harbor Brook FEMA-approved 100-year floodplain, equating to roughly 91.05 ha (225 acres) [17].

### 5.2.2 History of Harbor Brook and the Harbor Brook Flood Control Plan

Over time, the relationship between Harbor Brook and the downtown HUB site became detrimental to both. “At least eleven major flooding incidents since the late 1860s have caused substantial economic damage in Meriden’s central city” [17]. In 1992 and 1996, major floods – caused in part by an Amtrak Bridge south of the downtown business district that was undersized and sitting at a very low profile to Harbor Brook – cost the city an accumulated \$26 million (USD) worth of property damage. In 1992, further financial loss occurred when a flood caused a major employer (more than 300 employees) to relocate outside downtown [18].

As a result of these significant flooding problems, the city developed and began to implement the Harbor Brook Flood Control Plan. It is a comprehensive set of flood control measures along Harbor Brook, with the dual purpose of alleviating historic flooding problems and providing a new economic development zone adjacent to their new TOD (transit-oriented district) [17].

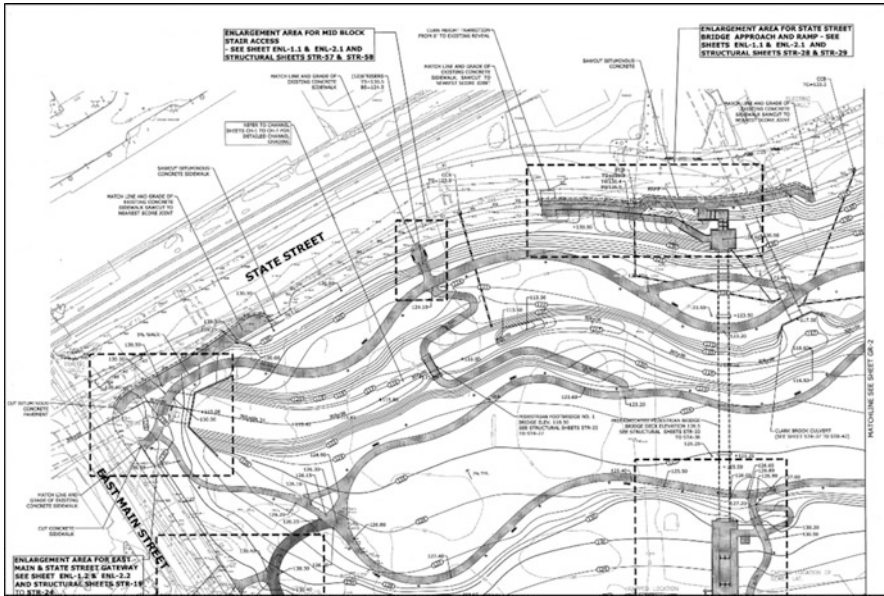
Key flood control components in the plan are:

- Floodwater detention areas – the HUB site is expected to provide 21.45 ha (53 acres) of stormwater storage.
- Harbor Brook channel improvements – widening and deepening the existing channel to improve overall hydraulic capacity and realigning the channel to take fuller advantage of the HUB site acreage.
- Continued replacement and removal of hydraulically inadequate bridges along Harbor Brook from Center Street to Hanover Pond.
- Construction of retention/detention ponds on the east side of the city (to slow down floodwaters prior to reaching the HUB site).
- Daylighting Harbor Brook

### 5.2.3 Project Details

The daylighting portion of the project involved removing twin, concrete box culverts to expose the existing stream channel. Each box culvert was  $2.13 \times 4.57$  m ( $7 \times 15$  ft) – basically a 9.14-m (30-foot) wide underground channel. The new stream corridor is designed to be a low flow channel sitting at one elevation, which will handle a typical 2-year storm event. The bottom of the channel is reinforced with heavy-duty stone; the stream banks are similarly armored with varying sizes of boulders all the way to the top of each slope, where the material transitions to vegetation (Bass R, 2015, Director, City of Meriden, CT, Department of Public Works/Engineering Division, personal communication).

Harbor Brook is not the only underground stream getting daylighted with this project: adjacent Jordan Brook was also removed from about 18.29 m (60 ft) of concrete culvert, and nearby Clark Brook was slightly daylighted and rerouted around an existing bridge pier. Both tributaries will converge with Harbor Brook on



**Fig. 7** Harbor Brook stream daylighting grading and site plan. Site design and plan graphics by Milone & MacBroom, Inc., Cheshire, Connecticut (USA), July 31, 2013 (Image courtesy of Robert Bass, P.E., Director, Department of Public Works/Engineering Division, Meriden, CT)

the 5.83-ha (14.4-acre) public park site, which has now been regraded and designed to withstand floodwaters from a 100-year storm event (Fig. 7) (Bass R, 2015, Director, City of Meriden, CT, Department of Public Works/Engineering Division, personal communication).

Construction by LaRosa Construction, Inc., began with initial building demolition and the removal of hazardous material. During that process, special scaffolding had to be placed over culverted sections of Harbor Brook to catch falling building material that was itself contaminated with asbestos. City engineers did not want any harmful chemicals entering the stream channel, so this method was employed as a preventive measure [19]. In spite of that, the project is well on track to meet its contracted completion date of December 31, 2015 (Bass R, 2015, Director, City of Meriden, CT, Department of Public Works/Engineering Division, personal communication).

“The City’s Capital Improvement Program calls for the completion of \$22.15 million (USD) in [flood control project components] over the next five years (2014-2018)” [17, p 1], in addition to the HUB site development costs. According to Robert Bass, P.E., Director of the Public Works Department for the city, the final project expenditures came close to costing nearly twice the initial estimates due to previously unknown underground hazardous materials that the city removed and properly disposed of. A 5.30-m<sup>3</sup> (1400-gallon) oil storage tank, with product still contained inside, was discovered during excavation, which required removal,

disposal, and soil mitigation in order for construction to move forward (Bass R, 2015, Director, City of Meriden, CT, Department of Public Works/Engineering Division, personal communication).

#### 5.2.4 Outcome

The redevelopment of the HUB site – including daylighting Harbor Brook – will store floodwaters in certain storm conditions to prevent flooding in the immediate downtown area. It will also provide ample outdoor space for a large amphitheater and great lawn for public events, “a town green that Meriden for historic reasons never had” [17, p 3]. This central green space will be combined with a linear trail system right alongside the Harbor Brook channel to provide a recreation link diagonally across the city (Fig. 8) [17].

Additionally, 227 properties will be removed wholly or partially from the 100-year floodplain, opening up the project site to 139,354 m<sup>2</sup> (1.5 million ft<sup>2</sup>) of new development area “without the risk of economic damage from future flood events” [17, p 4]. The overall acreage within the 100-year floodplain will be reduced from 91.05 to 38.45 ha (225–95 acres) [17].

In addition to controlling floodwaters and creating a much-needed centralized park, one particular outcome of the daylighting and flood control project is especially gratifying for the city – it is generating a high level of economic interest among business developers keen to move into the heart of the downtown business district. The interest is so high, that it has unexpectedly shifted priorities away from bridge replacement to stream daylighting. Site construction will be completed in less than 1 year, and the stream channel has been widened and deepened to remove



**Fig. 8** Harbor Brook stream daylighting and HUB redevelopment site. Site design and plan graphics by Milone & MacBroom, Inc., Cheshire, Connecticut (USA) (Source: Westport CT Master Plan, 2013)

the entire park from the 100-year floodplain. As a result, Bass says “Bridges come second now” (Bass R, 2015, Director, City of Meriden, CT, Department of Public Works/Engineering Division, personal communication). The revitalization of Harbor Brook comes first, as it has become a catalyst for the rapid revitalization of economic investment in downtown Meriden.

### **5.3 Case Study 3: Little Sugar Creek, Kings Drive and Midtown Reaches, Charlotte, North Carolina (USA)**

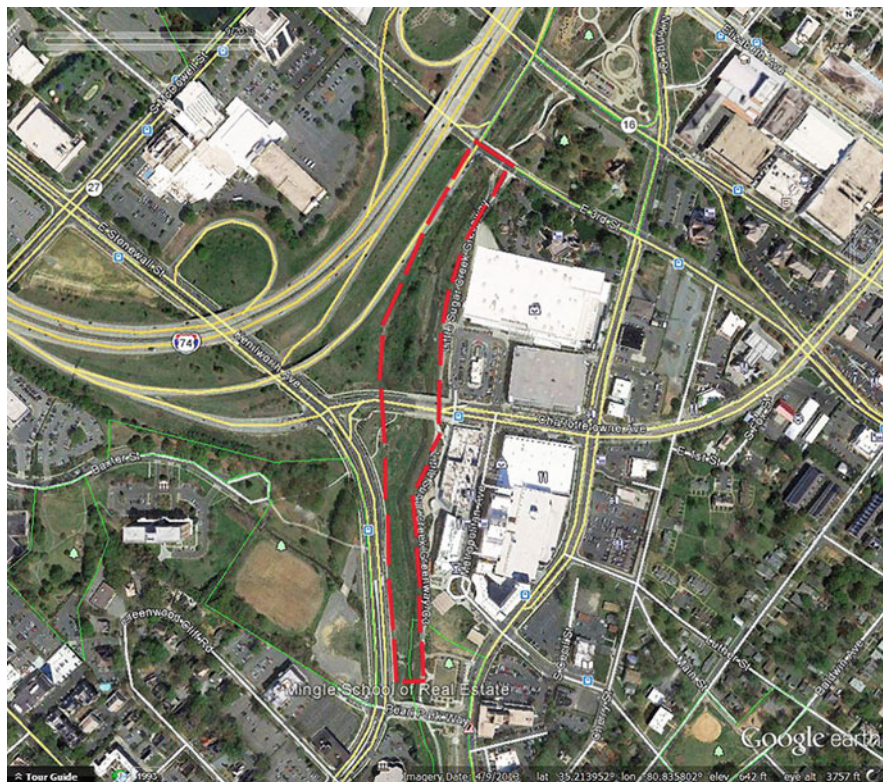
#### **5.3.1 Context**

Little Sugar Creek and its major tributary, Briar Creek, drain 132.09 km<sup>2</sup> (51 mi<sup>2</sup>) in and around Charlotte, North Carolina (USA). Little Sugar Creek travels through Mecklenburg County, North Carolina – beginning just west of a ridge that divides the Catawba River watershed from the Yadkin–Pee Dee watershed. Little Sugar Creek continues south through Mecklenburg County to join Sugar Creek which continues to the Catawba River east of Rock Hill, South Carolina (USA). “The Little Sugar Creek watershed is located in a highly developed urban setting; approximately 80 % of the land in the watershed has been developed. Approximately 43 % of the land surface is impervious. The land uses within the watershed include residential (47 %), industrial (25 %), commercial (19 %), woods (7 %), and institutional (2 %)” (Fig. 9) [20, p 1].

#### **5.3.2 History of Little Sugar Creek**

Little Sugar Creek was rendered vulnerable to countless problems caused by poor treatment from residents, businesses, and governments. From the time of the city’s founding in the 1760s, residents and businesses took full advantage of nearby streams as places for dumping raw sewage from outhouses and then apartments, as well as industrial waste and chemicals like gas and chlorine [21].

As suburban America boomed after World War II, downtown Charlotte expanded. On October 28, 1959, almost 50,000 people turned out for the grand opening of the Charlottetown Mall (aka Midtown Mall), the southeastern USA’s first enclosed shopping mall. The mall’s concrete parking lot was built on top of Little Sugar Creek. “Nearby businesses wanting parking space did the same thing, putting Little Sugar Creek in the dark for more than 40 years” [21, p 6]. Over the course of modern history, much of the creek had been altered to accommodate development. In a report prepared by Buck Engineering in 2006 for the City of Charlotte, “The creek has historically been dredged and maintained as a flood control channel. Most of the banks have been armored to prevent erosion from high flow velocities. The creek has been capped to accommodate commercial use: the Midtown Square parking cap extends for (32.61 m) 170 LF just upstream of



**Fig. 9** Little Sugar Creek, Kings Drive reach, Charlotte, North Carolina (USA) (Source: Unknown 2013, as displayed in Google Earth™)

Morehead Street. The former McDonald's cap extends for (208.79 m) 685 LF through the middle of the project reach. The former Bank of America parking cap extends for (64 m) 210 LF near the upstream portion of the project" [20, p 2].

### 5.3.3 Project Details

As part of the effort to improve water quality and flood control along the highly urbanized stream in downtown Charlotte, the city implemented a prominent segment of a \$42 million (USD) project called the Little Sugar Creek Greenway. The project had two main goals, to create a trail to serve as a destination for tourism and recreation and to improve water quality [22]; some of this was achieved by adding natural meanders, pools and riffles, rain gardens, and natural/native plantings along the banks of the creek.

Design plans were prepared to uncover Little Sugar Creek and install natural channel designs meant to improve water quality and re-create the natural conditions





**Fig. 10** Little Sugar Creek prior to construction, Meredith Moore, Mecklenburg County Storm Water Services (Image courtesy of Crystal Taylor, P.E., Charlotte–Mecklenburg Storm Water Services, 2002)

of the creek. The project was broken into several phases that reflected different stream reaches along its urban corridor. The entire [daylighting] project was from 7th Street to Morehead Street. The bulk of the uncapping occurred in the reaches called Kings Drive and Midtown (Taylor C, 2015, Charlotte–Mecklenburg Storm Water Services, personal communication). The drainage area at this point in the watershed is 17.14 km (10.65 miles) [23]. The Kings Drive reach “was almost 100 % capped with concrete lined banks and concrete cover (Fig. 10). This reach was stable due to the concrete lined channel, however, there was no buffer and the water quality and habitat were very poor in this reach. The goal for this reach was to uncap [sections of] the channel and construct a new channel and floodplain bench. It would also include adding riffle and pool bedform features using boulder structures to improve water quality and provide vegetative buffers for habitat and stability” [23, p 3].

Approximately 685.8 m (2250 ft) of covered stream were daylighted from Midtown Square along Kings Drive to Morehead Street. 174.66 m<sup>2</sup> (1880 ft<sup>2</sup>) of parking lot coverage was removed (Fig. 11) [11]. To improve aquatic habitat, “Boulder cross vanes and riffles were installed to improve the fish and

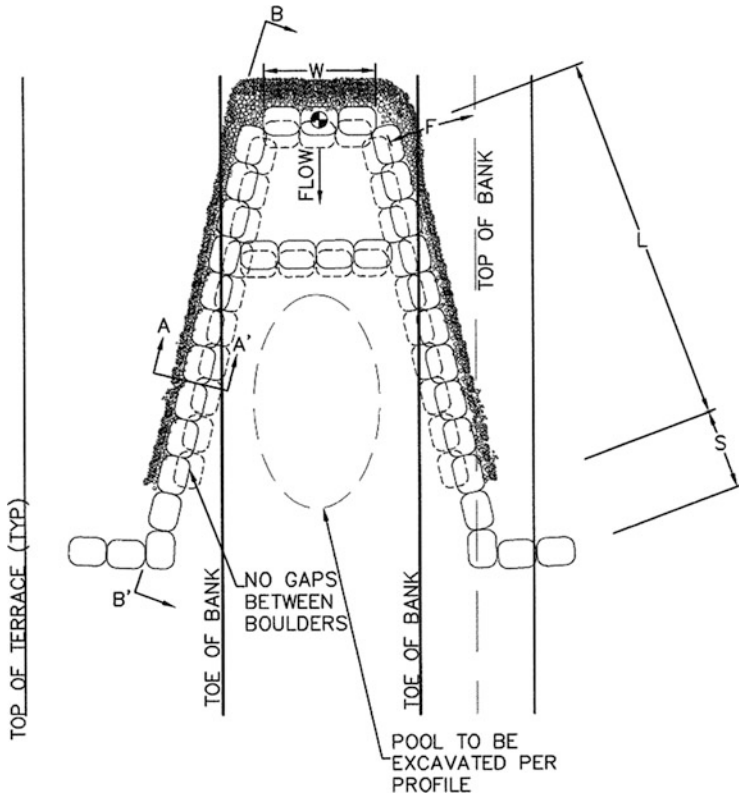


**Fig. 11** Former Midtown Mall parking deck during demolition, Jay Higginbotham, Mecklenburg County Asset and Facility Management (Image courtesy of Crystal Taylor, P.E., Charlotte–Mecklenburg Storm Water Services, 2007)

macroinvertebrate habitat in the stream by providing the riffle and pool sequences that a healthy stream requires. The cross vanes will also protect the stream bank from erosion while lowering the stress on the stream banks during storms” (Fig. 12) [23, p 5].

“As part of the project, the Charlotte–Mecklenburg Utility Department planned to install a 60-inch relief sewer which enabled the sewer line to relocate from the left bank of the stream to the right bank closer to Kenilworth Avenue. This allowed the stream restoration project to construct a large floodplain bench on the right bank and meander the creek away from the left bank into the left floodplain area” (Fig. 13) [23]. According to Crystal Taylor, P.E., of Charlotte–Mecklenburg Storm Water Services Department, “The low flow bankfull channel was designed for the 28.31 cubic meter/second (1000 cubic feet/second) event which is between the 1- to 2-year event. Because of the urban nature of the project and the constraints (power transmission lines, 1-277 ROW, sewer lines, etc.) we could not add true geomorphic energy reducing meanders. We added in meanders where we could, but they are more aesthetic meanders” (Taylor C, 2015, Charlotte–Mecklenburg Storm Water Services, personal communication). To implement the greenway-specific part of the project, plans required a 30.48-m (100-foot) riparian buffer and buyouts of flood-prone properties which then facilitated constructing 1931.21 m (6336 ft) of greenway trail and one pedestrian bridge that connects Kings Drive to Harding Place [21].

The extensive and intricate nature of the phased project required a collaborative effort to pay for it. Funding partners included the North Carolina Clean Water



**Fig. 12** Little Sugar Creek cross-vane detail, Michael Baker Engineering, Inc., Charlotte, North Carolina (USA), May 12, 2009 (Image courtesy of Crystal Taylor, P.E., Charlotte–Mecklenburg Storm Water Services)

Management Trust Fund, Department of Water Resources, Mecklenburg County Park and Recreation, Charlotte–Mecklenburg Storm Water Services, and the Charlotte Department of Transportation. Fortunately, no changes occurred to the scope of work during the design and implementation of this project [23].

### 5.3.4 Outcome

“Overall, the project went well and there were no major issues during construction. At the beginning of the construction, the design had to be completely modified in the field because of poor soils that were found in the location of the meander bend. The poor soil is believed to be the sediment deposition that occurred along the original alignment of the stream. The stream design was modified to include a boulder toe to ensure stability in the channel and along the stream bank. An old bridge concrete foundation was discovered during excavation of where the new

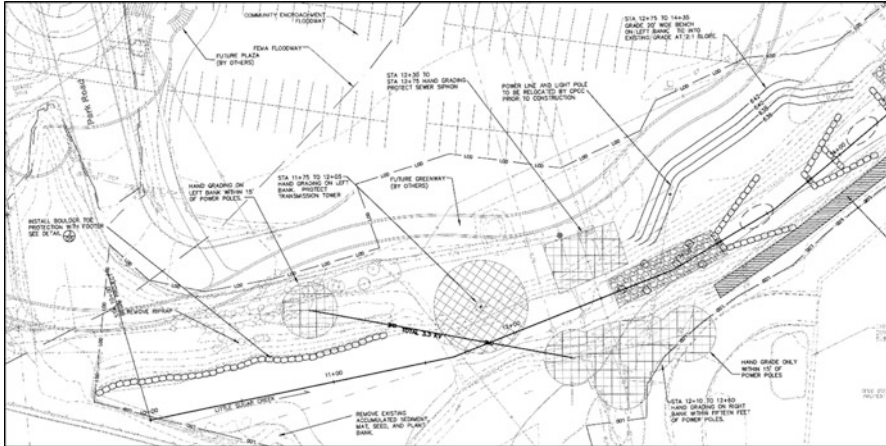


**Fig. 13** Little Sugar Creek after construction, Meredith Moore, Mecklenburg County Storm Water Services (Image courtesy of Crystal Taylor, P.E., Charlotte–Mecklenburg Storm Water Services, 2012)

channel would tie into the original channel just upstream from the former Baxter Street Bridge” [23, p 6].

In spite of recreating a more natural channel for Little Sugar Creek – with meanders, in-stream habitat, stable banks, wetlands, and floodplains – severe urban constraints caused by dense property lines and utilities have limited the creation of its full natural channel [11]. As a result, Little Sugar Creek is considered in the early stages of partial recovery, but not full recovery. In certain areas, “wetland plants are growing faster than expected, and the presence of fish, insects, frogs and mussels has noticeably increased” [11, p 19]. However, ongoing water quality tests reveal that the stream is still polluted. Its upper and lower sections are still rated as “impaired” due to turbidity, copper, fecal coliform, and, in the upper section, mercury [21].

Even so, there are hopeful signs on the horizon. The estimated average bank erosion rate prior to construction was 88 metric tons/year (97 tons/year); the estimated average bank erosion rate after construction is 44.45 metric tons/year (49 tons/year) [23]. “There has been very little streambank erosion since the project was constructed. Water quality monitoring in the stream has not been completed on a regular basis because over the last several years there were portions of the overall project under construction. Mecklenburg County’s Water Quality Program has



**Fig. 14** Little Sugar Creek construction plans, Michael Baker Engineering, Inc., Charlotte, North Carolina (USA), May 12, 2009 (Image courtesy of Crystal Taylor, P.E., Charlotte–Mecklenburg Storm Water Services)

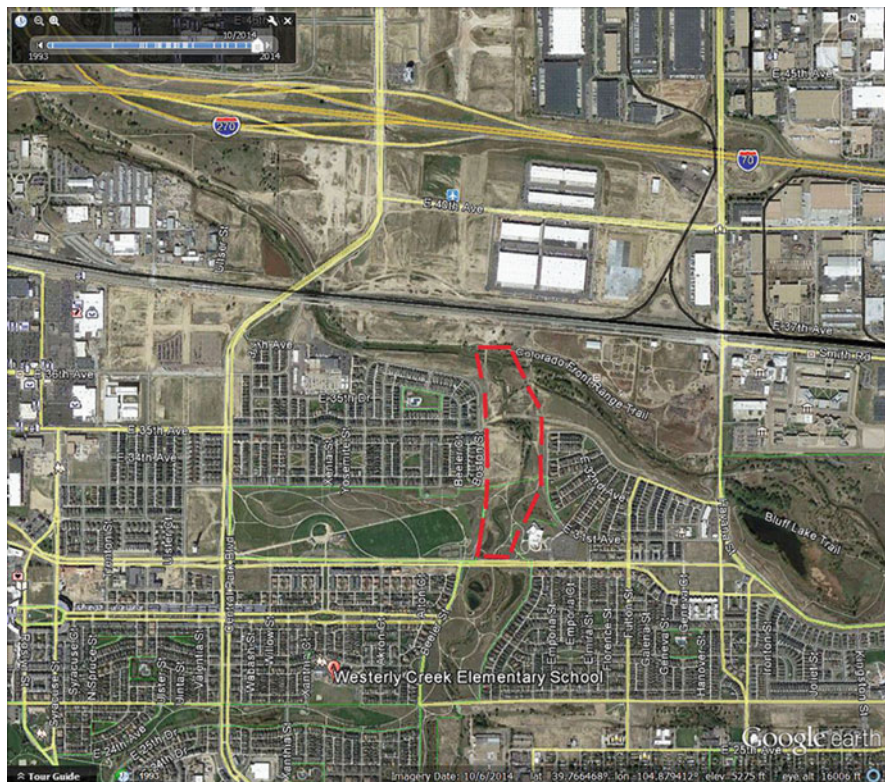
completed fish sampling and found a fish species, called the Tessellated Darter, in the stream that has not been present in this stream in decades” [23, p 6].

Buck Engineering determined at the conclusion of the project that this stream reach currently classifies between a Rosgen B4 and G4. “An absolute Rosgen stream classification of urban streams such as Little Sugar Creek is difficult due to historical channel modification and the limited ability of the channel to freely adjust to its channel-forming agents because of utility and infrastructure constraints.” [20, p 3]. Engineers like Barbara Doll, water quality specialist for North Carolina Sea Grant, and Crystal Taylor say they realize they can never take Little Sugar Creek back to the conditions of an undisturbed stream. “But do you give up on urban streams all together because you can’t do that?” Doll asks. “We can recover a lot of ecological value to these streams, even in the highly confined spaces of urban watersheds” [11, p 19] (Fig. 14).

## 5.4 Case Study 4: Westerly Creek, Denver, Colorado (USA)

### 5.4.1 Context

The Westerly Creek watershed consists of 47.91 km<sup>2</sup> (18.5 mi<sup>2</sup>) of mostly developed land in Denver and Aurora, Colorado (USA). Westerly Creek is a long tributary that sits on a north-south axis along the eastern edge of the City of Denver (Fig. 15). It is a tributary to Sand Creek with a typical base flow of approximately 0.08 m<sup>3</sup>/s (3 ft<sup>3</sup>/s) [24] which ultimately drains into the South Platte River. It drains an area in both Aurora and Denver along its journey from Cherry Creek State Park,



**Fig. 15** Westery Creek at Stapleton, Denver/Aurora, Colorado (USA) (Source: Unknown 2014, as displayed in Google Earth™)

through the Lowry Air Force Base redevelopment zone and Westery Creek Village. The northern section of the creek travels through east Denver and Aurora. The southern section traverses Lowry Air Force Base (now decommissioned and redeveloped as a mixed-use residential–commercial zone) and the Stapleton International Airport redevelopment site [25]. It is an “open channel from Montview Avenue to the east-west runway near Stanley Aviation where it enters parallel 274 cm (108-inch) diameter and 167 cm (66-inch) diameter culverts 658 m (2,160 feet) long. . . These culverts convey only 42.48 cubic meter/second (1,500 cubic feet/second) (28 %) of the predicted 100-year flood flow of 150 cubic meter/second (5,300 cubic feet/second) in this reach and are a significant restriction to larger discharges” [26, p 2].

The Stapleton redevelopment site contributes 4.53 km<sup>2</sup> (1.75 mi<sup>2</sup>) of the drainage area. “Due to the hard-pipe connection of storm sewers between Lowry and Stapleton, the watershed is vulnerable to rainfall events and historically has produced high flows under even typical summer storm events” [27, p 3].

### 5.4.2 History of Westerly Creek

As with all the other case studies, Westerly Creek was treated as an obstacle. “Smaller drainages with low average flows, such as Westerly Creek, were not carefully studied for their flood damage potential. Growth in original Aurora in the late 1800s through the mid-1900s unfortunately followed this practice....both in Aurora and Denver. . .Many flood events have been recorded in the Westerly Creek watershed” [25, p 3].

Over the course of several decades, efforts to alleviate flood hazards – through construction of drainage-related infrastructure – included [25]:

- Construction of the Kelly Road Dam in Denver (1950s)
- Construction of a combination of underground culverts and open channels in Aurora and Denver to handle 10-year storms (1980s)
- Construction of the Westerly Creek Dam as a regional stormwater detention dam (1990s)

Unfortunately, a large part of the conveyance capacity of Westerly Creek remained inadequate to protect properties along its course. In spite of the above construction projects, the creek system still could not convey a 10-year storm event without major flooding impacts [25]. “A 100-year flood was predicted to sheet flow over the runway and taxiways creating an exceptionally wide flood hazard area through the site of the former Stapleton International Airport” [24, p 2].

### 5.4.3 Project Details

In 1989, the City of Denver decided to build the Denver International Airport instead of expanding landlocked Stapleton International Airport. When Stapleton was decommissioned on February 27, 1995, the 1902.02-ha (4700-acre) airport site became “one of the largest underdeveloped parcels of land in the heart of a major U.S. city” [27, p 1]. Partly to control urban flooding and partly to spur infill development at the abandoned airport, city leadership opted to pursue daylighting Westerly Creek. This newly uncovered stream corridor would become the impetus for a large sustainable, mixed-use development zone.

“Initial work required the demolition of approximately 4.0 hectares (10 acres) of existing airport runway over the Westerly Creek corridor and excavation of approximately 576,474 cubic meters (754,000 cubic yards) of material. Pipes were removed, creek channel cut in, and banks stabilized with buried riprap. ValleyCrest, one of the landscapers, built several boulder jetties using 1.2 m–1.5 m (4- to 5-foot) boulders to slow creek flow. ValleyCrest also built an 85 linear meter (280-linear foot), 0.60 meter (2-foot) high wall using Staplestone, chunks of crushed recycled runway, near a set of benches on a trail” [27, p 4].

The new “low flow channel will be 1,310 meters (4,300 feet) long, 5.5 meters (18’ wide), have a depth of between 0.6m-0.9m (2-3 feet) with an average depth of



**Fig. 16** Westerly Creek at Stapleton in early channel construction (Image courtesy of Jane Kopperl, Matrix Design Group (EDAW) 2002)

0.76 m (2.5 feet), with typical 4:1 side slopes (Fig. 16). It will carry between 5.66-8.50 cubic meters/second (200-300 cubic feet/second)” [27, p 5], which is 3–5 % of 2-year and 10-year storms [27]. The upper tier stream banks were constructed at 4:1 slopes; closer to the toe of the stream banks, and extending approximately 0.91 m (3 feet) below the invert of the channel, buried riprap was installed at a 2:1 slope. “The Urban Drainage and Flood Control District required stabilizing the new channel by burying riprap in the banks” [27, p 4]. However, the channel bottom will be earthen and un-vegetated and will be allowed to meander within an approximately 22.86-m (75-ft) wide corridor bounded by riprap-soil revetment [26].

A unique feature of the Westerly Creek corridor is the construction of three regional water quality ponds at select locations on the project site (Fig. 17). These stormwater ponds provide water quality treatment at each outfall point before the urban runoff can enter the stream system [27]. The “first flush” of stormwater goes through these crescent-shaped structures made of “Staplestone” and then passes through constructed wetlands which suspend sediment, filter nutrients, and remove bacteria before entering Westerly Creek (Fig. 18). “These regional ponds were kept outside the floodplain to the extent possible and provided easy access for maintenance programs” [24, p 1]. At the same time, “High flows will bypass the wetlands through a wide channel and flow directly to the Creek. The three wetlands will have a total storage volume of 2.13 hectares-meters (5.28 acre-feet) and a total surface area of about 0.97 hectare (2.4 acres). The normal pool depth will be between .015m-0.91m (0.5-3 feet) deep” [26, p 6].

From a landscape standpoint, the toe of the channel is protected along its outer bend by vegetated biologs placed in 3.04-m (10-foot) lengths of 3.65-m (12-foot)





**Fig. 17** Architectural outfall structures at constructed wetlands (Image courtesy of Jane Kopperl, Matrix Design Group (EDAW) 2002)



**Fig. 18** Outfall structures and constructed wetlands after construction (Image courtesy of Jane Kopperl, Matrix Design Group (EDAW) 2004)

and 4.87-m (16-foot) widths and is held in place by wooden stakes (Fig. 19) [26]. “Extending past the bio-logs in a 10’ strip is a biodegradable bristle coir woven blanket used to retain the soil layer above the rip rap to provide a planting medium for shrubs and wetland plugs” [26, p 7]. The daylighted stream banks and urban park and greenway trails were planted with a palette comprised of 85 % native and naturalized plant species for all three landscape zones in the project: wetland, riparian, and upland. “Ecologically, the corridor is targeted for a variety of



**Fig. 19** Vegetated biologs at installation (Image courtesy of Jane Kopperl, Matrix Design Group (EDAW), 2003)



**Fig. 20** Westerly Creek at Stapleton after construction (Image courtesy of Jane Kopperl, Matrix Design Group (EDAW), 2006)

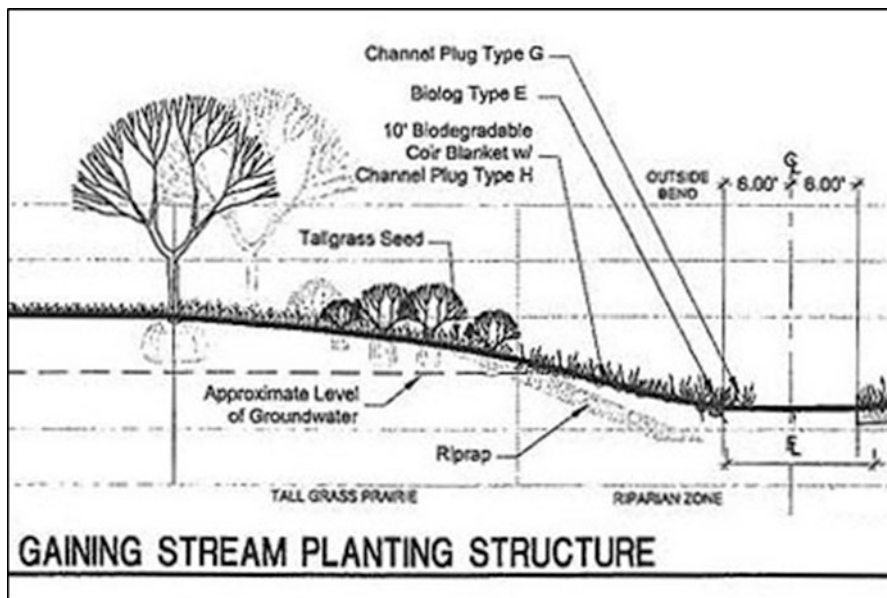
small mammal and bird species that historically inhabit the Sand Creek corridor to the north. Habitat is provided with the planting of native and drought-tolerant trees and shrubs, wetland plants, and grasses, creating ecozones similar to eastern Colorado foothills and prairie wetland transitioning to a mid-grass prairie environment” (Fig. 20) [24, p 2].

Recycled Materials, Inc., started removing and recycling 5,896,700 metric tons (6.5 million tons) of runways, taxiways, and pavement in 1999. It took 6 years to complete, “as 907,184 metric tonnes (1 million tons) a year is as much as the market can absorb” [27, p 5]. The construction sequence started with the installation of hydraulic structures and revetment and channel shaping. Trails and bridges were completed a year later, followed by landscape planting a few months after that [24].

#### 5.4.4 Outcome

The Westerly Creek restoration “was not a pure stormwater engineering project nor was it a pure ecological project. It is a hybrid of the two resulting in a non-traditional approach to designing a stormwater conveyance system that demonstrates the mechanics and biological functions of a natural creek channel while benefiting urban wildlife and the residents of the Stapleton community and surrounding environs” [24, p 2]. Furthermore, it is a unique channel design, given its more natural appearance in such an urban environment. Hard controls are buried in the stream banks and the fairly wide floodplain allows the stream channel to meander freely and evolve to its natural sinuosity and dimension over time (Fig. 21) [24].

As a result, the Westerly Creek sub-watershed was decreased from approximately 74.06 ha (183 acres) to 26.71 ha (66 acres) by increasing flood storage



**Fig. 21** Construction and planting details (Image courtesy of Jane Kopperl, Matrix Design Group (EDAW) 2002)

capacity of the stream from 42.48 m<sup>3</sup>/s (1500 cfs) – which was 28 % of the predicted 100-year storm – to 169.90 m<sup>3</sup>/s (6000 cfs) or 113 % of the predicted 100-year storm event. Flood flows were reduced an average 44 % and water velocity dropped to an estimated 0.30–1.52 m/s (1–5 ft/s) at low flow and 0.91–1.52 m/s (3–5 ft/s) at peak flow. This helped reduce the erosive force of the water during storms [28].

The original daylighting of Westerly Creek at Stapleton was completed in 2004. The project was so successful that it has spurred several more stream restoration projects throughout the Denver/Aurora region. 2015 is becoming a “year of enormous changes in the big picture” with three current stream channel restoration, realignment, and stream bank modification efforts already underway. One longer-term vision of community leaders is to unite these individual projects into “a cohesive watershed-based greenway system” [29, p 3].

According to the City of Aurora’s governmental website, “Ongoing development of the former Lowry Air Force Base and Stapleton Airport has dramatically changed the character of Westerly Creek as it passes through these new, mixed-use developments...the creek has been reclaimed...into a continuous, naturalized channel...[and] has become a centerpiece of these projects. It is now a major amenity that...is celebrated by not only the immediate neighborhoods but the larger community as well” [25, p 5].

## 6 Conclusions

Comparing current stream daylighting projects and their spin-off projects with those that were reviewed in 2006, a noticeable progression from very small lengths of stream in fairly open rural and suburban sites to ever more complex, multi-phased downtown urban stream reconstruction is being accomplished. Projects are larger, more collaborative, and far more likely to employ scientific methods of stream assessment, classification, and mathematical modeling prior to stream channel construction.

Natural stream channel design principles work effectively within almost all urban environments, even if the level of intervention is different for each stream reach and/or community. The levels of intervention correspond well to site constraints that may limit how naturalistic a newly unearthed stream form can take, but they still offer some relief and restoration to parts – if not all – of a stream’s ecological function and health.

In previous case study reviews, it was found that the primary goal behind daylighting appeared to be the creation of a public park or recreation area that would benefit people. Flood control and water quality improvements were secondary. The four case studies presented in this chapter indicate a potential shift in priorities; flood control and downtown economic development are emerging as driving factors behind restoration efforts, followed closely by improving water quality and expanding habitat corridors. The creation of parks amenities –

greenway trails, town “greens,” and recreation areas – is dovetailed onto the daylighting projects as an added community benefit (and potential fundraising bonus) but is not the key focus.

From the standpoint of green infrastructure, all the case study projects have successfully reduced urban flooding. Daylighting has remained a viable green infrastructure alternative to traditional hard engineering; in fact, it is becoming the preferred retrofit method for handling urban flooding in several locations. New stream channels replace failing culverts and underground pipes and greatly reduce dangerous stormwater overflows and flood damage. Even some sections of stream that required repair after significant storm events did not require extensive repairs, and none of the case studies to date have reported complete failure.

Examples such as Harbor Brook (Meriden, Connecticut, USA) and Westerly Creek at Stapleton (Denver, Colorado, USA) – once buried to facilitate development – are now heralded as centerpieces to their communities’ urban financial and environmental health. The problems inadvertently created by the previous approach of burying stream systems were so great, that today the process of uncovering streams has become the driving catalyst behind economic and neighborhood recovery.

## ***6.1 Recommendations for Future Research***

Each of the previous case studies warrants deeper review and monitoring of results, because of their respective scopes and complexities and their differing locations. Both Indian Creek and Harbor Brook are still under construction at the time of this writing, but very close to completion, so a follow-up investigation of their intended performance as flood storage sites and community parks is highly recommended. Little Sugar Creek’s ongoing water quality monitoring plan can become a model for other communities wishing to achieve similar results; a careful review of their methods and metrics for assessing water quality improvements would help to establish a set of design and construction guidelines tailored specifically to urban streams to be daylighted.

Tracking actual costs versus anticipated or unpredicted costs can give designers, developers, and construction firms a clearer understanding of what daylighting-specific issues may cost, in terms of design needs, construction timelines, permits, and site issues. Monitoring vegetation establishment can help city managers and public works departments revise their landscape maintenance practices to prevent weed encroachment and human–animal conflicts and develop strategies for disposing of vegetated material that may itself become contaminated by pollutants and nutrients over time.

It is currently more cost effective for landscapes at floodplain plantings to be irrigated with potable water rather than using wastewater treatment plants effluents which could reduce the nitrogen levels discharged from those facilities (Kopperl J, 2015, Matrix Design Group (formerly with AECOM during Westerly Creek initial

construction phases), personal communication). However, a full-scale investigation into the nitrate uptake capacity of native plants being irrigated with recycled water from municipal wastewater treatment plants would help local government and health agencies better understand which species most effectively perform this function.

## References

1. Butler D, Davies JW (2004) Urban drainage, 2nd edn. Spon Press, London/New York, p 566
2. James W (1998) A historical perspective on the development of urban water systems. University of Guelph, Guelph. <http://chiwater.com/Company/Staff/WJamesWebpage/technology/wj437hi.htm>
3. Levine A (2014) From creek to sewer: a brief overview of topographical change in Philadelphia. Philadelphia Water Department, Philadelphia. <http://www.phillyh2o.org>. Accessed 15 Sept 2006
4. National Park Service (Undated) Giving new life to streams in rural city centers. <http://www.nps.gov/nrc/rivers/projpg/DAYLIGHT.PDF>. Accessed 20 Sept 2006
5. Benedict MA, McMahon ET (2006) Green infrastructure: linking landscapes and communities. Island Press, Washington/Covelo/London, p 320
6. Pinkham R (2000) Daylighting: new life for buried streams. Rocky Mountain Institute, Colorado
7. Buchholz T (2006) Urban stream daylighting: case study evaluations. Masters' thesis, Department of Landscape Architecture, in conjunction with the Virginia Water Resources Research Center, Virginia Polytechnic Institute and State University
8. Brown K, Schueler T (2004) Urban stream repair practices manual no. 4. Center for Watershed Protection, Ellicott City. Manual produced for the United States Environmental Protection Agency, Office of Water Management, Washington, DC
9. Alliance for the Chesapeake Bay (2002) Guidelines for natural stream channel design for Pennsylvania waterways. [https://crallianceforthebay.org/wp-content/uploads/2010/08/Guidelines-NSCDesign\\_PA.pdf](https://crallianceforthebay.org/wp-content/uploads/2010/08/Guidelines-NSCDesign_PA.pdf)
10. Stream Mechanics, PLLC and U.S. Fish and Wildlife Service (2011) Natural channel design review checklist. Prepared for the United States Environmental Protection Agency. <http://www.fws.gov/chesapeakebay/StreamReports/NCD%20Review%20Checklist/Natural%20Channel%20Design%20Checklist%20Doc%20V2%20Final%2011-4-11.pdf>
11. Angione K (2007) Cracking the culvert: urban stream restoration in North Carolina. Coast Watch. <http://www.ncseagrant.org>. Accessed 5 June 2015
12. Philadelphia Water Department Office of Watersheds, Darby-Cobbs watershed overview. © 2016 Philadelphia Water. Accessed February 3, 2016.
13. Wikipedia. Cobbs creek watershed data. <http://en.wikipedia.org>. [https://en.wikipedia.org/wiki/Cobbs\\_Creek](https://en.wikipedia.org/wiki/Cobbs_Creek). Last modified August 3, 2015. Accessed 21 Apr 2015
14. Fisher C (2014) City 'daylights' first creek, restoring it from sewer to stream. <http://www.planphilly.com>. Accessed 21 Apr 2015
15. Gates KP (2013) Daylighting project reveals a hidden creek. <http://www.planphilly.com>. Accessed 21 Apr 2015
16. United States Army Corps of Engineers (2014) Army Corps, Philadelphia Water Department to celebrate ecosystem restoration. Release no. 14-006
17. City of Meriden, CT (2013) Harbor Brook flood control project overview. <http://www.cityofmeriden.org>. Accessed 12 May 2015

18. Blumenthal R (2014) United States senator for Connecticut. Blumenthal, Murphy, Esty Announce \$2.46 million federal grant to alleviate longtime Meriden flooding. <http://www.blumenthal.senate.gov/newsroom>. Accessed 12 May 2015
19. Brechlin D (2014) Demolition of Meriden buildings expected to resume this week. Record-Journal. <http://www.myrecordjournal.com>. Accessed May 2015
20. Buck Engineering (2006) Little sugar creek kings drive reach stream enhancement supporting data. PCN 401/404 certification package
21. Newsom M (2015) Keeping watch 2015: an in-depth look at the creeks of Charlotte. <http://www.keepingwatch.org>. Accessed 5 June 2015
22. Charlotte-Mecklenburg Storm Water Services (CMSWS) (Undated) Facts and figures: urban little sugar creek greenway. [http://www.charmeck.org/mecklenburg/county/ParkandRec/Greenways/LittleSugarCreekGreenway/Documents/LSCG\\_Fact\\_Sheet.pdf](http://www.charmeck.org/mecklenburg/county/ParkandRec/Greenways/LittleSugarCreekGreenway/Documents/LSCG_Fact_Sheet.pdf)
23. North Carolina Clean Water Management (2012) Little sugar creek stream restoration project phase 9 final report. North Carolina Clean Water Management Trust Fund project 2007-404
24. Kemme F, DeGroot B, Krehbiel R, Leach M, Kopperl J (2004) Comprehensive stormwater management at stapleton. 2004 CASFM conference project awards
25. City of Aurora, Colorado (Undated) Westerly Creek vision. <http://www.auroragov.org>. <https://www.auroragov.org/cs/groups/public/documents/document/010241.pdf>. Accessed 30 June 2015
26. Matrix Design Group (2002). Request for conditional letter of map revision. Westerly Creek channel restoration – phase I
27. Carder C (Undated) New life at an old airport. Progressive Engineer (© 2011). [http://www.progressiveengineer.com/features/new\\_life\\_old\\_airport.htm](http://www.progressiveengineer.com/features/new_life_old_airport.htm). Accessed 30 June 2015
28. Canfield JL, Cunningham K, Koehler K (2011) Westerly Creek at Stapleton – Denver, CO. Methodology for landscape performance benefits. Landscape architecture foundation landscape performance series case study. <http://www.landscapeperformance.org/case-study-briefs/westerly-creek-at-stapleton>. Accessed 30 June 2015
29. Hyde B (2015) The watery ways of Westerly Creek. <http://greaterparkhill.org/2015/03/watery-ways-westerly-creek>. Accessed 30 June 2015

# Sustainable Water Management in Green Roofs

Francesco Orsini, Mattia Accorsi, Paulo Luz, Ioannis L. Tsirogiannis,  
and Giorgio Gianquinto

## Contents

1	Introduction .....	168
2	Water Management in Green Roofs .....	170
2.1	Water Management .....	170
2.2	Irrigation Water Quality .....	180
2.3	Rainfall, Runoff, and Green Roofs as Rainwater Harvesting Systems .....	183
2.4	Regenerated Water for Green Roof Irrigation .....	185
3	Green Roofs for More Efficient Cities .....	188
3.1	Green Roofs and Ecosystem Service Provision .....	189
3.2	Environmental Assessment .....	197
4	Conclusions .....	200
	References .....	202

**Abstract** In this chapter, the contribution of green roofs in management of the urban water cycle is addressed. Primarily, proper water management strategies are presented, with specific regard to the sustainable practice of irrigation and the definition of water quality standards. We reference the application of alternative water sources, such as rainwater harvesting and gray water regeneration. Then, the environmental, ecological, and financial benefits associated with rooftop greening are described, including reference to life cycle cost assessment. Ecosystem service

---

F. Orsini (✉) • M. Accorsi • G. Gianquinto  
Agricultural Sciences Department, University of Bologna, Viale Fanin, 44, 40127 Bologna,  
Italy  
e-mail: [f.orsini@unibo.it](mailto:f.orsini@unibo.it)

P. Luz  
Instituto Nacional de Investigação Agrária e Veterinária, I.P., Av. da República, Quinta do  
Marquês, 2784-505 Oeiras, Portugal

I.L. Tsirogiannis  
Department of Agricultural Technology, Technological Educational Institute of Epirus, 47100  
Kostakii Arta, Greece



provision is analyzed in specific relation to the role played by water in improving urban microclimate and air quality and promoting resilience to climate change.

**Keywords** Ecosystem service provision • Green infrastructures • Rooftop agriculture • Urban water cycle

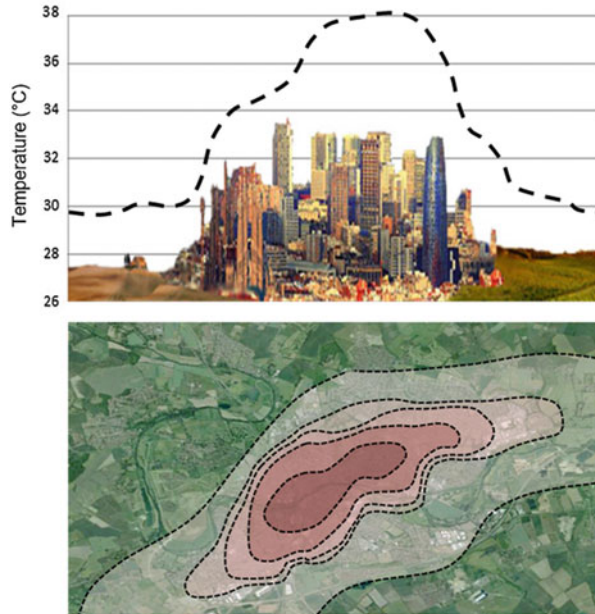
## 1 Introduction

The past few decades are characterized by a continuous, intense, and complex process of urbanization; today almost 54 % of the world population inhabits urban areas, and in Europe, three quarters of citizens live in metropolitan regions [1]. Consistently, reconciliation between the development of our cities with respect and protection of the environment is becoming an important challenge. Cities are composed of structures and extensive interventions of anthropogenic origin, which make them poles of environmental problems [2]. In many cases, a significant percentage of a city's soil surface is sealed by impervious materials, surfaces that do not absorb water and increase the occurrence of runoff. Furthermore, most structural materials used in such environments are generally characterized by low albedo (a measure of the reflectivity of the surface), a fact that intensifies the conversion and storage of the incident thermal radiation to sensible heat when compared to the surrounding countryside. Therefore, the urban surface layer tends to be hotter than the rural one [2, 3]. This effect is exacerbated in cities where green infrastructures are scarcely present. In other words, as green transpiring surfaces are replaced by impermeable soil cover, the water available for evaporation is reduced, affecting the flow of latent heat. Therefore, especially in the absence of precipitation, the value of Bowen ratio (sensible heat flux/flow latent heat) becomes quite high [4].

When isothermal curves are plotted on a surface weather map, the result is a profile that looks like the topographic contours of an island (Fig. 1) – the reason why the urban surface layer is also called “heat island” (urban heat island or UHI) [2]. In highly populated cities, the higher temperature is related to the higher emissivity of surface materials, an increased energy consumption for building air conditioning, and an effect of the pollution associated with road traffic (including sulfur dioxide, carbon monoxide, nitrous oxides, and suspended particulates) [5]. Pollution effects may be exacerbated in climates with a distinctively hot season [6, 7].

A number of recent studies [8, 9] point out that increase of green infrastructure in urban environments contributes to mitigation of microclimate problems and also to a wide range of ecosystem services, such as improving air and water quality [10, 11], mitigating stormwater runoff [12], providing resilience to exceptional meteorological events [13, 14], or improving urban biodiversity [15]. Furthermore, functions of green infrastructure may also be social (e.g., aesthetic, recreational,

**Fig. 1** Graphical representation of the heat island effect on the skyline of a city (*top*) showing the differences of temperature between rural and urban areas during the afternoon. The temperature in downtown may exceed in measure of 8–10 °C the surrounding countryside. The image below is a simulation of the typical surface temperature map from which it is possible to observe the urban heat island (UHI) effect (Image by second author)



educational, etc.) as well as financial ones (e.g., by increasing the property values). All such aspects are strongly related to the water cycle. Although the diffusion of urban green infrastructure is being promoted by many governmental and nongovernmental agencies for increasing city resilience, the architectural and urbanistic features of most cities make prohibitive the construction of new gardens or green parks, where soil and vegetation work as buffers and filters. Consistently, the conversion of concrete surfaces (e.g., walls or rooftops) into green areas is becoming a commonly diffused strategy. In this chapter, the environmental functions provided by green roofs will be introduced, with a particular view on the role they can play on the urban water cycle and, overall, on ecosystem services. This chapter presents and analyzes information on many environmental benefits provided by green roofs and addresses information on how water is managed in green roofs, discussing specific design and management elements, and identifies water quality standards and potential for using alternative water sources (e.g., rainwater or regenerated water) for irrigation.

## 2 Water Management in Green Roofs

### 2.1 Water Management

Many challenges and impacts require consideration when addressing water needs for green roofs. The increasing risk of climate change unpredictability determines the need for adapting water management strategies to both more resilient green covers and the inclusion of irrigation efficient methods, which is particularly true in dryer climates (e.g., in the Mediterranean basin), characterized by extreme weather events as droughts or scattered but intense rainfalls. Moreover, water management should utilize interdisciplinary approaches, allowing a better understanding of crosscutting water resource issues [16], which are crucial to assess the connection between soil-plant-atmosphere continuum and irrigation options and the implementation of successful and sustainable solutions.

Irrigation systems for green roofs need to account for the special characteristics unique to these kinds of projects. Consistently, the main elements to be considered when planning irrigation of green roofs are described in Table 1, i.e., various environmental and policy features for consideration when identifying practical recommendations. The number and nature of topics to be considered, with respect to a specific project, should be linked to the different scenarios of parameters and detail levels. Beyond the scope of this section, which is to present basic information, other items and more comprehensive checklists and inventories of information are available in irrigation handbooks [17–19]. For example, more elements could be provided to promote a better knowledge about conservation techniques, local atmospheric conditions, habitats, solar radiation, historical hydrological variability and budget, water reservoirs, and reuse facilities, among others. Another important point is the use of gray water concerning different types of farming as described in the World Health Organization (WHO) guidelines [20], identifying practices and standards for the treatment, control, and use of wastewater, including several considerations and restrictions (a topic which is discussed in more detail in chapter “[Urban Wastewater for Sustainable Urban Agriculture and Water Management in Developing Countries](#)”).

However, we note that water management issues, dealing with the water cycle and the soil-plant-atmosphere continuum, are not “exact sciences.” Factors involved in irrigation projects are sometimes uncertain, incomplete, or unreliable, thus leading to suboptimal precision levels [21], and achieving a high efficiency of urban irrigation systems is not straightforward, since its performance is affected by many constraints, e.g., high variability (spatial and temporal) of soils and microclimates, variable water/hydraulic supply and operating conditions, vegetation quality and architectural patterns, etc. [22]. For these reasons, in order to improve green roof planning, innovative skills and technical ability must be developed. Furthermore, advanced irrigation management strategies should include the formulation and ranking of suitable project alternatives, which may be supported by application of statistical and modeling tools and techniques based on updated information from data platforms and resource evaluation. These procedures also

**Table 1** Irrigation development framework to green roof planning. Linkages between irrigation management and environmental factors (*Sources*: irrigation [18, 19]; soil and water [24, 25]; climate [23, 26]; agro-environmental indicators and methodological tools [27, 28]; urban agriculture and green roofs [29, 30]; socioeconomic and governance [31, 32])

A – Irrigation guidelines			B – Green roof plots	
Topic	Conditions and factors	Actions and practices	Challenges (from concerns)	Impacts (from suitable irrigation)
Quality of natural resources	Quality level Soil Water Air Range of parameters	Filters application Chemical and biological classification and monitoring Resources use within allowable limits	Standards and criteria to sustainability Resource low quality Contamination and pollution Wastewater application and treatment	Minimization of environmental degradation Resource remediation Increased available water Healthy activity
Soil use	Structure and texture Organic substrate Infiltration rate Depth Available water	Methodologies to soil evaluation Soil moisture measurements	Cultivation practices Low infiltration and poor drainage Control of wetted surface	Ensure soil conservation (e.g., structure, fertility) Proper water application to infiltration and soil water deficit Uniformity of wetted space
Climate	Parameters Wind Evapotranspiration Rainfall Temperature	Collect parameter data to define water balance Irrigation in cooler periods of the day	Constraints as urban heat island or frost Water shortage periods	Cooling effect Improve urban areas’ resilience to climate variability (or change) Mitigate drought periods
Plants and biodiversity	Stages Root depth Water requirements Sensitivities Pests/diseases	Rotations Vegetation cover Pest/disease control Use of tolerant crops or varieties to overtake restrictions	Food quality Low range tolerance for some factors management Soil-water-climate constraints (e.g., for sensitive crops)	Provide habitats for many species Healthy food Plants adaptation to irrigation system Yield increase
Irrigation system – water use	Design Management System capacity Water pressure	Layout (i.e., outlet spacing, flow, pressure) Water balance (proper MAD for scheduling) Water application control	Lack of technical skills Water balance interactions (irrigation-rainfall) and supply Excessive flow	Sustainable high-tech solutions High operational performance (efficiency, uniformity) Prevent ponding and waterlogging

(continued)

**Table 1** (continued)

A – Irrigation guidelines			B – Green roof plots	
Topic	Conditions and factors	Actions and practices	Challenges (from concerns)	Impacts (from suitable irrigation)
		(e.g., frequency, rates)	or water application rates Sediment content and filtering needs Storage in rain collectors	Clogging resistance
Irrigation system – energy	Pumping system Total dynamic head Supply hours Sources (availability)	Low pressure Optimized pump power Correct maintenance	Alternative energies Water-energy nexus Excessive energy consumption	Increasing efficiency and sustainability Innovative technologies Best daily timing criteria
Socioeconomic	Financial resources Unit area cost Financial funding and instruments	Proper equipment with good quality Operationality in periods with lower cost energy Comparative analysis of irrigation systems	Trade-off: economic vs. agri-environmental High cost of infrastructures High operating costs Limited financial resources	Compromising solutions Indicators' ranking to balanced performance Suitable cost-benefit ratio
Governance	Specific legislation Regulation criteria Educational and cultural issues	Application of: System of indicators  Benchmarking techniques Decision support tools (techno-economical)	Lack of: Knowledge of standards and key indicators Training and expertise Planning Market to products	Best irrigation strategies and practices in urban farming organizations Scaled implementation Stakeholders compromise on ecological behavior

contribute to increasing public awareness about the main benefits and disadvantages associated with each option, integrating their technical, ecological, economic, and social components. Then, as large-scale implementation of green roofs is being promoted and observed across the world, it must be ensured that they improve the quality of urban life and help adapt areas to expect hydrological variability and climate change [23].

### 2.1.1 Irrigation System Selection

Evaluation and selection of irrigation systems should consider a number of factors and criteria as related to design layout, scheduling, performance, resource efficiency, and socioeconomic issues and enable the user to establish decisions, comparing the adaptability of installation options to site-specific conditions. Making use of proper tools (e.g., a decision support or expert system) to classify and rank the feasible irrigation systems according to their suitability to input factors, the selection process will consist in evaluation stages, while meeting needs, constraints, and beneficial procedures [21], preferably based on case studies provided in experimental plots. Main topics and factors needed to develop a selection procedure are presented in Table 2. Using micro-irrigation systems as a comparison, this table was compiled with detailed information from several handbooks and commercial catalogues available in most world markets for irrigation equipment.

#### Notes

The brief analysis of the factors presented in Table 3 (focusing evaluation of topics 2–6 with main comparative limitations of systems, given by factors with level 3) resulted on the basis of the following considerations:

#### 1. Operational

- Micro-irrigation systems provide low flow rates. Typically, values in drip irrigation are close to  $2 \text{ L h}^{-1}$ . Water applied through micro-spray heads will range from 20 to  $100 \text{ L h}^{-1}$ , but flow is still classified as low
- Required spacing between emitters depends on soil/substrate properties and plant type/density, generally ranging from 1.5 to 4 m in microsprinklers and less than 1 m in drip irrigation. In microsprinkler irrigation, it is important to achieve an overlap of wetted areas, meaning the spacing of outlets must be close to 100 % of the wetted radius. In drip irrigation projects shall propose only a slight overlapping between the wetted areas of emitters along the lateral. A dry area between crop rows is usually expected in drip systems
- The application rate determination is based on flow rates and wetted areas (Box 1) and shall be lower than final infiltration rate (explanation is provided in Sect. 3.1.2). The micro-irrigation emitters usually provide rates ranging from 5 to  $40 \text{ mm h}^{-1}$ , in agreement with expected infiltration rates increasing (and soil wetting areas decreasing) from fine to coarse textured soils, respectively
- An important parameter for such systems is pressure, and typically emitters operate under low pressure (typically up to 1.5 bar)

#### 2. Soil

- “Tape”: volume of wetted soil is very limited, “subsurface”: not suitable unless soil is nonsaline

**Table 2** Guidelines for irrigation system selection in GR plots [18, 19, 21]

Factor categories and factors		Microsprinkler	Drip		
			Tape	Emitters	Subsurface
1. Operational	Flow rate ( $L h^{-1}$ )	20–100	1–3	1–8	1.5–3.5
	Spacing (m)	1.5–4.0	0.15–0.6	0.3–1.2	0.3–1.0
	Application rate ( $mm h^{-1}$ )	5–20	5–40	5–40	5–40
	Operating pressure (m)	10–20	3–20	5–20	10–30
2. Soil <sup>a</sup>	Infiltration/runoff	2	2	2	1
	Infiltration/drainage	1	1	1	2
	Depth/AWC	2	1	1	2
	Wetting	1	3	2	2
	Salinity/sodicity	1	2	2	3
3. Climate/weather <sup>a</sup>	Control (extremes)	1	2	2	2
	Cooling	1	2	2	3
	Wind	3	1	1	1
4. Plant <sup>a</sup>	Water demand ( $ET_c$ )	2	1	1	1
	Canopy	3	1	1	1
	Pests/diseases/weed	2	1	1	1
	Cultivation/adaptation	2	1	2	1
	Germination	1	2	2	3
5. Water <sup>a</sup>	Salinity/sodicity/waste	2	1	1	2
	Sediments	1	2	2	3
	Efficiency	2	1	1	1
	Uniformity	2	1	1	2
	Frequency	1	1	1	1
6. Practices and maintenance <sup>a</sup>	Plot practices	1	2	2	2
	Clogging/leakages	1	2	2	3
	Control/scheduling	1	1	1	2
	Skill	2	2	2	2
	Automation	1	1	1	1
7. Cost <sup>a</sup>	Unit	2	1	2	3

<sup>a</sup>Qualitative comparative assessment of factors

1 – Lower/no limitations or high performance, 2 – Average conditions, 3 – Significant limitations or performance affected

**Table 3** Hydrological properties of soil/substrate texture classes [34]

Texture class	Effective hydraulic conductivity (mm m <sup>-1</sup> )	Volumetric water content (m <sup>3</sup> m <sup>-3</sup> )				Available water capacity (mm m <sup>-1</sup> )	Soil water deficit (mm m <sup>-1</sup> ) for MAD values of			
		Porosity	Effective saturation	Field capacity	Wilting point		25 %	50 %	75 %	100 %
Sand	200.0	0.44	0.42	0.12	0.04	80	20	40	60	80
Loamy sand	61.0	0.44	0.40	0.18	0.08	100	25	50	75	100
<i>Sandy loam</i>	25.0	0.45	0.41	0.22	0.10	120	30	60	90	120
Loam	13.0	0.46	0.43	0.26	0.11	150	38	75	113	150
Silt loam	7.0	0.50	0.49	0.33	0.15	180	45	90	135	180
Sandy clay loam	4.5	0.40	0.36	0.33	0.18	155	39	78	116	155
Clay loam	2.5	0.46	0.39	0.34	0.20	140	35	70	105	140
Silty clay loam	1.5	0.47	0.43	0.34	0.19	150	38	75	113	150
Sandy clay	1.2	0.43	0.39	0.34	0.22	120	30	60	90	120
Silty clay	1.0	0.48	0.43	0.41	0.27	140	35	70	105	140
Clay	0.6	0.48	0.39	0.36	0.24	120	30	60	90	120



### 3. Climate/weather

- “Microsprinkler”: problems with windy conditions, “subsurface”: soil surface remains dry reducing the plot cooling effects

### 4. Plant

- “Microsprinkler”: not suitable to many plants as spray effects may damage canopy, “subsurface”: more difficulties with seed germination and transplants, requiring other solutions to initial water requirements of some plants

### 5. Water

- “Subsurface”: water supply problems with high sediments content

### 6. Practices and Maintenance

- “Subsurface”: difficulties in detecting clogged emitters or leakages from buried laterals

### 7. Cost

- “Subsurface”: highest investment costs

Proper selection of an irrigation system must be carried out, taking also into account the substrate’s physical properties. Table 3 presents most typical substrate properties and moisture conditions from 11 texture classes. Effective (or saturated) hydraulic conductivity ( $\text{mm h}^{-1}$ ) is the parameter associated with the infiltration capacity limit of the substrate, and the water application rate (also in  $\text{mm h}^{-1}$ ) of irrigation shall never be above that value.

Other important parameters are the AWC (available water capacity) and the MAD (management allowed deficit) used to estimate the water deficit in the root zone. This deficit is considered in order to compute water application amount and to determine when irrigation is needed. Improved skills to scheduling practices, based on the substrate water balance, must be developed to answer “when” and “how much” to irrigate. Such practices shall point out solutions to prevent substrate water shortages or waterlogging taking into account specific urban environmental conditions. Several systems may be implemented to check and monitor substrate water levels and deficits. A common method for checking substrate moisture comprises appearance observation and hands feel. Consistently, knowing substrate texture can enable a green roof manager to understand the substrate moisture status based on the substrate features described in Table 4. Other methods with better accuracy may be used to control moisture level, at different substrate depths, along the crop stages. Substrate moisture sensors are more expensive means and require some training for proper installation and calibration. Using moisture meters to aid in irrigation scheduling may be relatively easy, but there are keys to success that need to be considered, as comparative procedures with visual inspection of the substrate, surface wilt, and response to irrigation inputs for a length of time before irrigation [33].

**Table 4** Guide for estimating soil moisture [35]

Soil moisture remaining	Moderately coarse texture	Medium texture	Fine and very fine texture
100 % (field capacity)	Upon squeezing, no free water appears on soil, but outline of ball is left on hand		
100–75 % (MAD: 0–25 %)	Forms a weak ball, breaks easily when bounced on hand	Forms a ball, very pliable, slicks readily	Easily ribbons out between thumb and forefinger
75–50 %	Will form a ball, but falls apart when bounced in hand	Forms a ball, slicks under pressure	Forms a ball, will ribbon out between thumb and forefinger
50–25 %	Appears dry, will not form ball with pressure	Crumbles, holds together with pressure	Somewhat pliable, will ball under pressure
25–0 % (MAD: 75–100 %)	Dry, loose, flows through fingers	Powdery, crumbles easily	Hard, difficult to break into powder

### 2.1.2 Irrigation and Drainage Configuration

The design process for a suitable pressurized irrigation system leads to a set of technical specifications comprising (1) system capacity (flow), (2) irrigation layout and selection of outlets (flow, distance, discharge rates, and pressures), and (3) water supply (water pumping, according to pressure and flow determinations).

Site-specific studies regarding a soil-plant-atmosphere continuum are a key component to ensure reliable irrigation design and management [36]. Rather than concentrating on analytical detail in an abstract sense, sequential sample calculations of a design process are extensively used [37]. Heavy irrigation or rainfall events may lead to substrate profile saturation, if the pore space of the substrate is filled with water [18], or to substrate surface ponding conditions if the event intensity is higher than the infiltration capacity. Related to these mechanisms, the occurrence of waterlogging and surface runoff in plots will cause damage to both plants (i.e., root asphyxia, diseases, etc.) and substrate (i.e., erosion, lack of aeration, etc.). Substrates of clay texture classes, with low infiltration capacity (see column in Table 3 – effective hydraulic conductivity), are more influenced by intensity-infiltration mechanisms, but sandy substrates, with low water storage capacity (see column in Table 3 – available water capacity), are more commonly affected by sudden saturation conditions. These problems may be controlled by drainage methods, which allow water to be efficiently removed from the substrate surface and mass, as it moves out (due to hydraulic potential gradients) through drain systems and materials to the lower point of water removal [38]. Drainage layers, drain holes, perforated drain pipes, and systems of channels are currently available technologies, and some of them may also provide the possibility for diverting water to storage infrastructures. Additionally, a proper micro-irrigation design and management will also contribute to the control of excess water. In light

substrates, with shallow root systems, irrigation is scheduled with small and frequent irrigation events (even twice a day) and the application rates of irrigation systems may be increased. In heavy and deep substrates, water application amounts may be increased (and frequency is reduced) and the application rate of emitters should be lower.

### 2.1.3 Green Roof (GR) Irrigation: Sample Calculation

In this section, the main topics and steps to be considered when implementing and managing an irrigation system in a green roof are presented. Sample calculations are provided following a simulation procedure concerning a green roof plot with some site-specific characteristics (Fig. 2). Data originate from direct measurements or estimated from reference figures or tables. Values obtained are then applied in

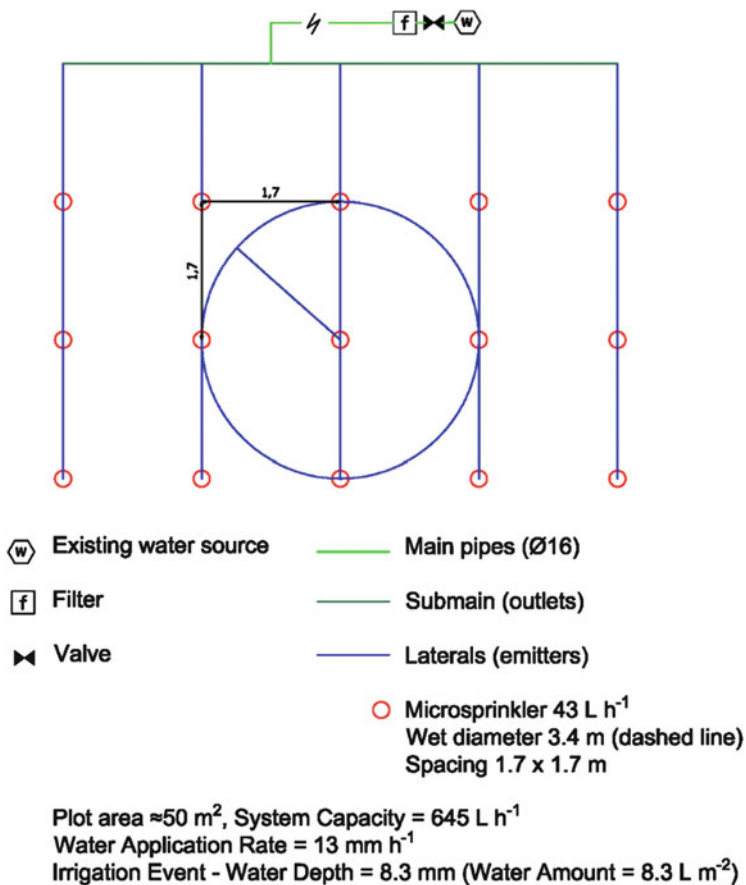


Fig. 2 Generic layout of a micro-irrigation system (Image by third and fourth authors)

the formulation of descriptive, qualitative, or quantitative indicators, enabling to complete the final irrigation management strategy:

1. Plot – an area of  $50 \text{ m}^2$  is considered.
2. Substrate water evaluation – an inventory of resources is completed which provides information about conditions of plot viability. Their quality is approached to identify water availability, infiltration capacity, and substrate and water chemistry (e.g., salinity/sodicity and pH). Resource characterizations considered are (a) sandy loam texture providing an available water capacity (AWC) of  $120 \text{ mm m}^{-1}$  and an infiltration capacity of  $25 \text{ mm h}^{-1}$  (Table 3), (b) plot structure with a substrate depth of 25 cm, and (c) substrate and water pH equal to 6.0 and electrical conductivity of substrate ( $\text{EC}_s$ ) and water ( $\text{EC}_w$ ), less than  $1.0 \text{ dS m}^{-1}$ . Maximum net depth of water application (MWA<sub>n</sub>), defined by substrate water deficit for MAD value of 25 %, is  $30 \text{ mm m}^{-1}$  (Table 3); thus, the substrate depth under consideration will reach 7.5 mm. Substrate physical and hydrodynamics characterization ensures a good infiltration. Substrate chemical characteristics, with very low salinity and almost neutral pH, will allow a nutrient cycling without problems of deficiency and toxicity [27] and are good indicators to the plant selection without restrictions [24].
3. Climate – the highest reference crop evapotranspiration (ET<sub>0</sub>) values, expected in summer, vary considerably in different climate zones. For instance, in Europe, the monthly ET<sub>0</sub> predicted can reach 200–250 mm in southern countries and 150–200 in the north depending on regions and years.
4. Plant – the main plant selection and cultivation factors that should be considered are (a) growth stages with effects on water demand and on allowable depletion; (b) crop evapotranspiration (ET<sub>c</sub>) along growth stages, reaching 5–10 mm day<sup>-1</sup> in summer in Europe; (c) root depth (substrate depth in this example) to determine the water application amount; (d) the spacing between plants and rows; (e) the tolerance to substrate and water quality; and (f) the adaptation to climatic factors. Many tables from irrigation handbooks may be used to access information from most plants [18, 19].
5. Water use – the physical layout of an irrigation system must be adjusted to the green roof plot conditions. Whenever water shortage occurs, the irrigation system must be able to deliver and apply the amount of water needed to meet the crop-water requirement [19]. In this example, MWA<sub>n</sub> is 7.5 mm and for system application efficiency attainable of 90 %, the gross water application will be 8.3 mm. During the peak consumptive use period, it is assumed that the needed water depth is 5 mm/day. Thus, the irrigation scheduling could be consistent with two irrigation events each three (3) days ( $2 \times 7.5 = 3 \times 5$ ). The selected kit, of 15 microsprinklers ( $43 \text{ L h}^{-1}$  each), applies a total rate of  $13 \text{ mm h}^{-1}$  ( $645 \text{ L h}^{-1}/50 \text{ m}^2$ ), lower than the infiltration capacity ( $25 \text{ mm h}^{-1}$ ), and will operate for 40 min for each irrigation event (or  $8.3/13 = 0.64 \text{ h}$ ).

Energy saving must also be a goal. Considering Table 2 guidelines, a low-pressure system (below 3 bars) with emitters discharging lowest flow rates

( $43 \text{ L h}^{-1}$ ; system capacity:  $645 \text{ L h}^{-1}$ ) and operating with an optimized/efficient water pump will require an installation of lower power.

6. Energy – in green roofs the selection of pressurized and preferably automated irrigation systems will result in high initial costs. Thus, a technical-economic approach, considering design alternatives of a system, must be made. For instance, in our sample, the investment may increase due to larger diameters of irrigation pipes, but energy costs (regarding a pump station) will be reduced (less pressure loss due to pipe friction). On the other hand, reducing pipe size will result in larger annual energy costs. In this economic method, with a hydraulic basis for selecting pipe diameters, the velocity of flow in main pipe shall be close to  $1.5\text{--}2 \text{ m s}^{-1}$  [37]. In this example an adequate option is to select an available commercial size pipe with a diameter of 16 mm. Following this procedure, the laterals with outlets and emitters may use reduced sizes. The impact of the number of emitters, spacing, and other parameters must also be properly evaluated, regarding suitable agro-environmental and economic options.
7. Economics – a final cost-benefit analysis is developed for the system, design, and management options, considering several engineering, operational, and maintenance expenses and economic, social, environmental, and marketing values [19, 39].

## 2.2 Irrigation Water Quality

In order to allow plant growth, water with certain quality standards should be used. While the need of providing a sufficient amount of water is always recognized, water quality issues are frequently overlooked. Although drinking water may present microbiologically acceptable features, its chemical composition (especially as a consequence of added chloride) may not be suitable for plant needs. Furthermore, due to its high cost and the overall need to save water, using alternative sources (e.g., rainwater, regenerated water, etc.) should be assessed in urban environments. When unconventional water is used for irrigation, appropriate and periodic tests should be conducted in order to verify its chemical and microbiological properties. When hydroponic cultivation systems are used, periodic water pH and EC measurements should be performed [40].

Analyses of water quality should be performed in order to avoid plant phytotoxicity, to rationalize plant nutrition, and to decide whether or not a water treatment unit is needed. If rainwater is used, seasonal variations may be encountered and should be taken into consideration. If municipal potable water is adopted, analyses are generally periodically provided by the public institution responsible for the water supply. However, interpretation of an analysis certificate can appear complex to those not in the business, for a number of reasons. The first difficulty is identification of the “threshold values,” i.e., the concentrations beyond which a certain substance can become harmful. Plant species have different levels of

tolerance and the growing techniques affect these thresholds. Furthermore, irrigation water quality must be assessed by examining the relationships between various quality parameters. Consistently, the opinion of an expert, having a thorough knowledge of the green roof in question, will certainly be more accurate as compared to fixed thresholds. Lastly, the units of measurement used to express the results may differ, making it difficult to compare different analyses or an analysis and a series of threshold values. The purpose of this section is therein to enable the reader to understand which parameters should be considered when choosing water for green roof irrigation. These parameters can be classified in the following categories:

1. Physical (temperature, suspended solids)
2. Chemical (gaseous substances, pH, alkalinity, soluble salts, element concentration)

### **2.2.1 Physical Features**

Water temperature should be as close as possible to that of the substrate explored by the roots. Cold water (below 75 % of the air temperature) should be avoided as it can cause plant stress. Therefore, adopting reservoirs where temperature can adapt to the environmental conditions is recommended. Warm water is alternatively useful in order to provide supplemental heat in coldest seasons, but when the temperature exceeds 35 °C, it may damage aesthetic properties (e.g., leaf spotting) and overall plant physiological functions. Suspended solids in the water may consist of substrate particles but also particulates contained in non-purified municipal wastewater. Although, generally, they do not directly affect plant growth, they may reduce aesthetic plant properties (e.g., by staining leaf tissues) or may clog irrigation nozzle and damage the water distribution system. This results in higher maintenance costs, as well as in possible occurrence of health and hygiene hazards.

### **2.2.2 Chemical Features**

Gaseous substances dissolved in the water may vary upon the presence of biodegradable substances which is a function of temperature. Indeed, given the low solubility of air in water, rainwater and surface water are generally preferred. Water use for irrigation may be restricted due to the presence of CO<sub>2</sub>, H<sub>2</sub>S, SO<sub>2</sub>, and CH<sub>4</sub>. Furthermore, chlorine (highly present in municipal water as a purifying agent) may be present in gaseous form; it becomes volatile when the water is exposed to both light and air.

Another important parameter is pH, which defines the water acidity or basicity (below 7 acid; 7 neutral; above 7 basic or alkaline). Water pH (together with the growing substrate) affects nutrient availability, with optimal values between 6.0 and 8.0. However, sometimes rainwater may present acidic pH (below 5), whereas

saline well or regenerated water may be basic (pH above 8.5). In these cases, correction is needed prior application. While pH defines water acidity or basicity, alkalinity is a relative measurement of water's capacity to resist a change in pH or to alter the pH of the growing substrate. It increases together with concentrations of carbonates and bicarbonates (generally expressed as ppm of calcium carbonate equivalents). When alkalinity is high, pH of the growing media will likely rise over time, therein requiring acid applications.

Another important parameter affecting water quality is the content of soluble salts, generally expressed as salinity of the water. Both groundwater and regenerated water may present high salinity, which will affect plant functions and, to the extreme, survival. Among dissolved salts, some are of greater concern, due to their toxic effect on plants, resulting in lower root water uptake, phytotoxicity, and alteration of substrate properties. The most frequently found dissolved salts are nitrates, chlorides, sulfates, carbonates, and bicarbonates of sodium, potassium, magnesium, and calcium. Measure of salinity may be performed analytically or by electrical conductivity methods. While analytical methods provide direct measurement of dissolved salts (e.g., expressed by  $\text{g l}^{-1}$  or  $\text{mg l}^{-1}$  or as concentration in ppm), electrical conductivity is linked to the osmotic pressure that a given saline concentration creates in the solution which, in turn, directly affects plant capability to absorb water. EC is expressed by millisiemens ( $\text{mS cm}^{-1}$ ) or microsiemens ( $\mu\text{S cm}^{-1}$ ) per centimeter or decisiemens per meter ( $\text{dS m}^{-1}$ ) as measured by a conductivity meter at  $25\text{ }^\circ\text{C}$  (where  $1\text{ dS m}^{-1} = 1\text{mS cm}^{-1} = 1000\text{ }\mu\text{S cm}^{-1}$ ), and water is defined as brackish whenever the EC is  $3.0\text{ dS m}^{-1}$  or more. Whenever dealing with salty water, agronomical practices can help to minimize losses, for instance, by satisfying the leaching requirement (e.g., by application of exceeding water in order to flow away excessive salts from the root zone), by applying frequent irrigations (enabling the plant to absorb water upon needs), or by localizing (e.g., by using drip irrigation) water nearby roots. Leaching fraction calculation integrates a number of key attributes, including substrate porosity, gravitational potential (influenced by the substrate layer height), and especially irrigation volume (how much water is applied in each irrigation). A high percentage of leachate (over-irrigation) from containers removes salts and results in a large volume of runoff. In contrast, a reduction in leaching leads to more salt remaining in the container and becoming available to the plant.

The presence of toxic ions in the irrigation water may lead to phytotoxicity problems. Symptoms become observable whenever these ions build up in the plant tissue. Visible symptoms are strictly related to the ions that generated the toxicity phenomena, which are generally chloride, sulfur, boron, and sodium, or, at lower concentrations, trace elements (e.g., heavy metals derived from human activities, such as industry or traffic). In any case, as for salinity problems, toxicity problems are also increased during the period of greatest environmental evapotranspiration demand, meaning that where good quality water is available, it is best to use it during the hottest period of the irrigation season.

### ***2.3 Rainfall, Runoff, and Green Roofs as Rainwater Harvesting Systems***

The development of infrastructure of central water supply systems and the evolution of relevant technology in urban areas of developed nations created a belief in their populations that water is an inexhaustible natural resource. Without getting in the climate change debate, from time to time, and unfortunately more frequently during the last decade, periods of water shortages oblige authorities to take precautions and apply watering bans. However, even if the mass media and the environmental campaigns provide information regarding the fragility of ecosystems and the crucial point at which they stand, there is not yet a wide and strong sense for adopting sustainable solutions.

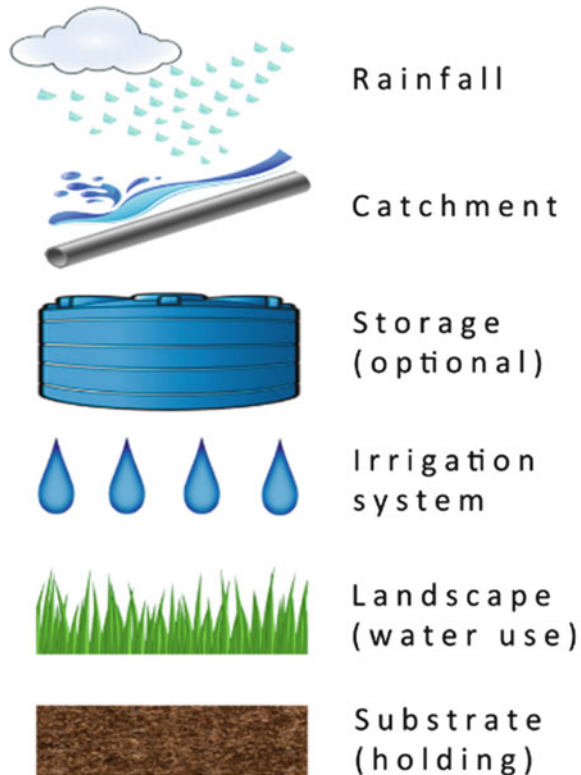
Rainwater harvesting (RWH) by constructing public and/or home reservoirs has a long tradition to provide water for irrigation purposes. Pipes (mainly by ceramic) and canals (mainly by stone) drive water to pools or underground cisterns [41]. Leaks are generally avoided by using waterproof internal coating. Rainwater runoff refers to rainwater which flows off a surface. In case of an impervious surface, runoff occurs almost immediately. For a pervious surface, such as a green roof, runoff will not occur until one of the following conditions is identified: (1) rainfall intensity exceeds the surface intake rate, or (2) the water storage capacity of the profile is lower than the water amount of the rainfall event. Runoff can be harvested (captured) and used immediately to irrigate plants or can be stored for later use. Rainwater has an advantage – when compared to other alternative water sources like gray and recycled water – in general it contains less contaminant, it is easily collected, and there are no legal limitations regarding its use for irrigation of nonedible crops. Probably the only disadvantage of such systems is the uncertainty of replenishment of the reserve.

In order to develop a sustainable rainwater harvesting system, aiming to satisfy irrigation water demand, a holistic approach should be applied and thus the system must be combined with appropriate substrate, native plants, mulching techniques, and an efficient irrigation system (regarding the design, quality of equipment, and operational performance). These systems can also be coupled with a number of other solutions like rain gardens, green roofs, and other bioretention systems. Rainwater harvesting systems range from simple to complex and are considered as low-impact development (LID) practices for an urban environment and a way to lower the urban “footprint.” Whether the landscape is large or small, a rainwater harvesting system is composed of the following basic components (Fig. 3): the supply (rainfall), the rainfall catchment (precipitation surface and conveyance pipes), the irrigation/distribution system that discharges water to the plants, and the demand system (substrate water holding capacity and landscape water requirement). Storage (Fig. 3) is an additional element which may be optionally integrated. Alternatively, rainwater is distributed immediately to the planted areas.

Green roofs are good examples of rainwater harvesting systems. They can keep an amount of water in their drainage layer and provide storm water retention (63 % on average in a variety of climates) [12]. Once maximum storage capacity is



**Fig. 3** Basic elements of a rainwater harvest system (Image by third and first authors)



reached, runoff water can be channeled into a gray water system and returned to the roof as irrigation [42]. If the rainwater harvested at the rooftop level exceeds the green roof requirements, it can be also used for irrigation of landscapes on lower floors or ground level, given its latent pressure which is very useful in case driplines are used (every 10 m of height difference corresponds to about 1 bar).

Regarding irrigation methods, the selection of a high effective type, like pressurized micro-irrigation systems (e.g., driplines or microsprinklers), is warmly suggested. In this category, subsurface dripline systems are also included. The water application efficiency (and uniformity) of such systems ranges between 80 % and 95 % [43]. When big green areas are to be irrigated, sprinkler systems are also a good solution. Their application efficiency is between 70 % and 80 % [44]. Proper zoning should also be applied during the design phase [45]. It is not clear by current legislation whether in case of rainwater, the system's components should be of contrasting color in order to signify that they do not deliver potable water, but it could be applied as a safety measure. For example, purple color is used in many cases [46, 47] for regenerated water distribution systems (pipes, valves, valve box caps, driplines, nozzles, etc.). British Standard BS8515:2009 for rainwater harvesting [48] indicate that all pipework should be in contrasting color (not

blue but green or black with green stripes), or material, to mains pipework and properly labeled.

Finally, an appropriate irrigation scheduling method should be provided and adjusted to the variability of water needs. An irrigation timer is suggested. In addition, a rain sensor attached to the timer is a must, as it would be ironic to irrigate from a rainwater reservoir while it rains. The use of other kinds of sensors like ET multisensor systems, soil moisture sensors, wind sensors, etc., could also contribute to higher irrigation efficiency. A simple and clear written plan containing information about irrigation scheduling, timer and sensor settings, system audit, and maintenance would contribute to the overall system efficiency.

## ***2.4 Regenerated Water for Green Roof Irrigation***

The pressure on water resources in Europe has encouraged more active consideration of using alternative water sources. Typical regenerated alternative sources of freshwater are recycled gray water and saline water. In a very recent European Commission's JRC Science and Policy Report [49], the need to find sustainable solutions to water challenges in urban, industrial, and agriculture sector was highlighted. In the same publication, a model for wastewater reuse potential in European countries up to 2025 was presented. The estimates suggest a wastewater reuse potential of  $3222 \text{ Mm}^3 \text{ year}^{-1}$  and among the EU countries; Spain shows the highest reuse potential as the calculations result in a value of over  $1200 \text{ Mm}^3 \text{ year}^{-1}$ .

Recycled water may be primary, secondary, or advanced (tertiary) treated municipal or industrial wastewater [50]. The characterization "recycled" refers in general to any water that has undergone one cycle of (human) use and then received sufficient treatment at a sewage treatment system in order to become suitable for various reuse purposes, including irrigation. Gray water refers to soft-treated or even untreated water that has gone through one cycle of use, usually in households or office buildings. Gray water by definition does not include the discharge from toilets or other uses that may contain human waste or food residues (which make up the sewage or blackwater). Gray water usually passes through appropriate filters before it can be used. As it contains many fewer pathogens than blackwater, it is more easily treated and recycled on-site for a number of purposes among which is landscape irrigation [51].

Saline or salt water refers to water with high salt content. If the salt content stands below a critical level, it can be used for irrigation purposes [52]. In the case of landscapes, its use can be broader as yield could not be among the goals and a variety of saline tolerant plants is available [53].

### 2.4.1 Water Reuse Application Risks

#### Agronomic Concerns

Reusable water for irrigation poses the risk of toxicity to plants because of dissolved salts. Some soluble salts are nutrients and therefore beneficial to plant growth but others are phytotoxic. Even the first category can be harmful if it is present in high concentrations. Sodium when accumulated or applied directly on the leaves of specific plants can cause injury. Recycled waters are prone to high bicarbonate ( $\text{HCO}_3$ ) levels.  $\text{HCO}_3$  is connected with increase of pH and SAR in circulating solution and adversely affects substrate permeability. Municipal recycled water may contain excessive residual chlorine, a potential plant toxin. Chlorine toxicity is almost always associated with recycled waters that have been disinfected with Cl-containing compounds. Boron, although is an essential micro-nutrient for plant growth, when applied in concentrations even as low as  $1\text{--}2 \text{ mg L}^{-1}$ , can be phytotoxic. Periodical monitoring of the applied water with chemical water analysis is a key component of good irrigation management [50].

#### Human Health and Environmental Concerns

Sources of reusable water may also contain a wide array of hazards including microbial, chemical, physical, and radiological agents that could pose a risk to human health and environmental matrices. In order to implement irrigation with alternative water sources, these risks must be mitigated. The most significant health and environmental hazards of using reclaimed water are due to pathogen microorganisms and chemical contaminants. Many microbial pathogens found in reclaimed water are enteric in origin. The numbers of pathogens will vary depending on rates of illness in the humans and animals that contribute to fecal waste [54–56]. Regenerated water may also contain elevated chemical pollutants that not only need to be considered from environmental aspect but also entail considerable long- or short-term risks to human health. These agents have cumulative effects that most often are not assessed [56, 57]. There are several treatment practices that can be applied to such an irrigation system in order to ensure safety. They include disinfection, filtration with either sand or activated carbon filters, aerobic biological treatment, ultraviolet radiation, or membrane bioreactor treatment [58].

### 2.4.2 Water Regeneration Systems and Green Roof Irrigation

It is common for water regeneration systems to directly distribute water to plants – after the completion of the treatment – without storing any amount. Nevertheless, regenerated water can be stored for a period, depending on the level of its treatment. The use of such water sources would be probably subjected to legal limitations and

relevant permissions. Only few published studies are available regarding the use of regenerated water in a green roof context [42, 59, 60]. A number of system layouts provide water treatment in various levels before it can be used for irrigation purposes [61].

In the case of green roofs, irrigation systems provide a number of advantages including the reduced demand for growth media depth, the augmentation of plant palette, and the protection of plant capital in case of severely hot weather [62]. In the case of regenerated water use, indicative signs regarding the water source should be placed, special care for filtering should be applied, and water should not be sprayed. Furthermore, as a general rule, the various components of the system should be colored purple. The use of purple color for the distinction of water type was first used in California more than 50 years ago. History says that it was an available yet easy to remember color (in the USA blue is for potable water; green is for sewers; yellow signifies natural gas, oil, petroleum, or something else that's potentially flammable; orange is for telecommunications; red is for power lines; and white is for marking where excavations and new pipe routes will go). Many standards around the world have adopted this color code (e.g., California Health Laws Related to Recycled Water June 2001 Edition the *Purple Book*, [46], the Greek legislative framework, relevant to irrigation using treated water [47]). Consistently, purple is not a universal standard but a practical selection that is expanding mainly through irrigation industry practice, since most major manufacturers now produce purple pipes to be used for regenerated water irrigation.

Where there is the possibility that regenerated water will enter the potable water system, a backflow prevention device should be installed. Drainage should also be taken into account. Diverting runoff from green roofs into a gray water system is another approach in minimizing the impact of green roof irrigation on regional water demand. Rooftop gardens as public concentration places, for the sake of aesthetics, oblige a more "hidden" irrigation system, which is not the case for green roofs. As it was noted for rainwater, in the overall concept of preserving water, all the precautions for developing and operating an efficient irrigation system should be considered.

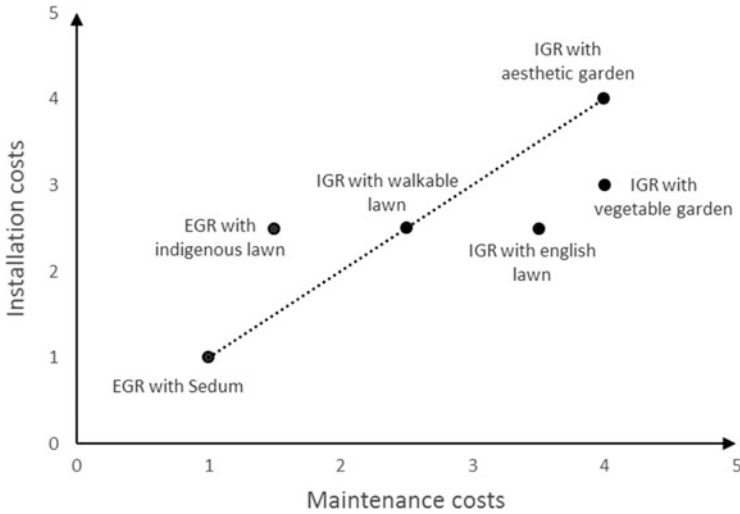
### 2.4.3 Standards, Guidelines, and Handbooks

Hundreds of national organizations or federal governments around the world refer to water reuse applications (like irrigation), treatment processes, water quality criteria, water monitoring, on-site preventive measures, and environmental monitoring and communication strategies [49]. Regarding gray water capture and reuse, there is a significant lack of legislative pieces in many countries, but there are many regulations and standards in the USA and Australia that set the framework for its application [58]. In European Union, the Urban Wastewater Treatment Directive [63, 64] requires that "treated wastewater shall be reused whenever appropriate" and "disposal routes shall minimize the adverse effects on the environment" [57], with the objective of the protection of the environment from the adverse effects of

wastewater discharge. Several member states and autonomous regions have developed their own legislative frameworks, regulations, or guidelines for water reuse applications. In Greece, for instance, a legislative act (Joint Ministerial Decision (JMD) 145116/2011, Governmental Gazette (GG) B 354 8/3/2011) and its amendment (JMD 191002/2013, GG B' 2220 9/9/2013), both in Greek, are based on 91/271/EEC to define the terms and procedures for the reuse of reclaimed water [47]. In Portugal, criteria for the adoption of urban wastewater for irrigation are defined in specific standards [65], which define limits to microbiological and physical-chemical parameters and also include irrigation system restrictions. In the UK, the application of wastewater in agriculture is quite common, mainly in golf courses, parks, and urban green infrastructures [66]. In Italy, based on the national regulation DM 185/2003, wastewater may be used for irrigation given that certain sanitary standards are met and that water-saving techniques are adopted [67]. In New Zealand, the “Guidelines for Sewerage Systems – Use of Reclaimed Water” provides information regarding irrigation using regenerated water [68]. The *Purple Book* of the State of California (Titles 17 and 22 of CCR/2001), which promotes and regulates the use of recycled water for various purposes (including irrigation), should be referred to as it was used as a basis for several relevant codes around the world. The United States Environmental Protection Agency (USEPA) published the “Guidelines for Water Reuse” [46]. The “WHO Guidelines for the Safe Use of Wastewater, Excreta and Greywater” refers also to the safe application of recycled water for irrigation [20]. Despite the water reuse applications already developed in many countries, a number of barriers still prevent the widespread implementation of water reuse. These barriers will have to be mitigated if wastewater reuse strategies are to be adopted on a larger and more effective scale than at present, developing the potential in terms of technologies and services related to water recycling in industry, agriculture, and urban sectors [49].

### 3 Green Roofs for More Efficient Cities

Green roofs are increasing in cities all around the world. Vegetated covers make use of a particular technology that combines living and dynamically evolving vegetation with static and long-lasting building structures. While building architecture roots on the concept of forecast capability and stability, nature is opposite, being autonomous and responsive to changes. As a consequence, adapting technical elements for protecting the building structure to host vegetation may result to being, at the same time, risky and intriguing. Where will the water go? How can plants survive seasonal climatic variations across the years? Which depth will the root system explore, and consistently, which substrates and technical solutions should be used to minimize drought and over-watering stresses? In order to address these questions, a first classification shall be made among the most represented green cover solutions, which directly consider their required maintenance and therein their installation and running costs. The most common classification is

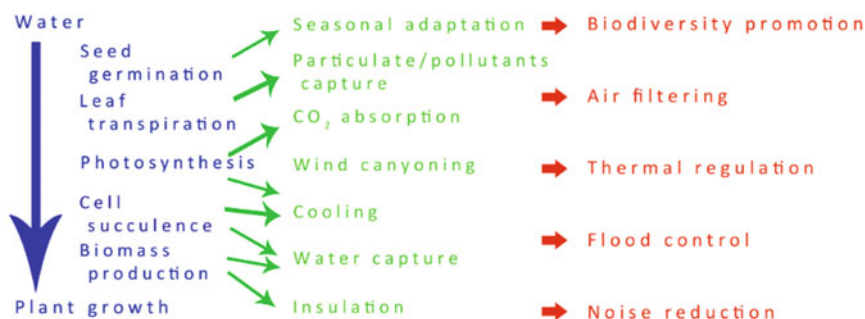


**Fig. 4** Classification of green roofs according to installation/maintenance costs and grown plant species (Image by first author)

between extensive (EGRs) and intensive (IGRs) green roofs. EGRs are those featuring shallow substrate depth, plants characterized by low water and nutritional needs and low need for maintenance. Typically, in EGRs a high percentage of the total roof area is covered by vegetation (in most cases hardy grasses, succulents, wild indigenous species, etc.), with almost no space for recreational activities. On the other hand, IGRs have deeper substrate layers, often hosting planter boxes and sometimes trees. This type of roof requires higher maintenance and is often accessible to residents and visitors. Hosted floras include walkable lawn, ornamental species with high aesthetic value, and edible crops. Changes in crop intensification are linearly correlated with installation and maintenance costs (Fig. 4). However, when designing and implementing a green roof, the evaluation of its financial viability shall consider a number of functions (reduced costs, improved building efficiency, etc.). In the following paragraphs, the main benefits associated with the building/city integration of green roofs will be explored.

### 3.1 Green Roofs and Ecosystem Service Provision

Green roofs can improve sustainability of the urban environment by providing a range of ecosystem services, each of them connected with the city water cycle. As efficiently summarized in Fig. 5, water affects all stages of plant growth, from seed germination to all the physiological functions that lead to plant growth and green biomass accumulation. Consistently, water availability will directly affect the whole green roof ecosystem, and this will be reflected in the magnitude of the



**Fig. 5** Relationship between water and main ecosystem services provided by green roofs (Image by first author)

many ecosystem services provided. Biodiversity is a function of seasonal variations in flora. Air filtration is associated with plant photosynthesis and canopy size. Thermal regulation reflects both transpiration and the related effects on wind canyoning. Water captured (and transpired) is associated with the whole canopy coverage and determines the potential for flood control. Finally, as water affects plant growth, the size of the plants and the water content of the substrate will affect the noise reduction function of the green roof.

The quantification of the ecosystem services provided is a complex procedure that must be adapted to local environmental and climatic conditions, as well as the technological level of the green roof solution adopted. Preliminary studies have addressed the quantification of these ecosystem services as summarized in Table 5.

**Table 5** Ecosystem services provided by green roofs (*Source:* First and second authors)

Ecosystem service	Unit	Rooftop [8, 15, 69–73]
Food production	Kg m <sup>-2</sup> year <sup>-1</sup>	15 [15]
Noise absorption	dB	-2/13 [69]
Thermal isolation (energy saving)	USD \$ m <sup>-2</sup> year <sup>-1</sup>	3.4 [8]
Facade cooling	°C	2–11 [70]
Air depuration		
CO <sub>2</sub> absorption	g m <sup>-2</sup> year <sup>-1</sup>	375 [71]
PM <sub>2.5–10</sub> adsorption		3.8 [72]
NO <sub>x</sub> and SO <sub>x</sub> adsorption		7.3 [73]

### 3.1.1 Water Regulation

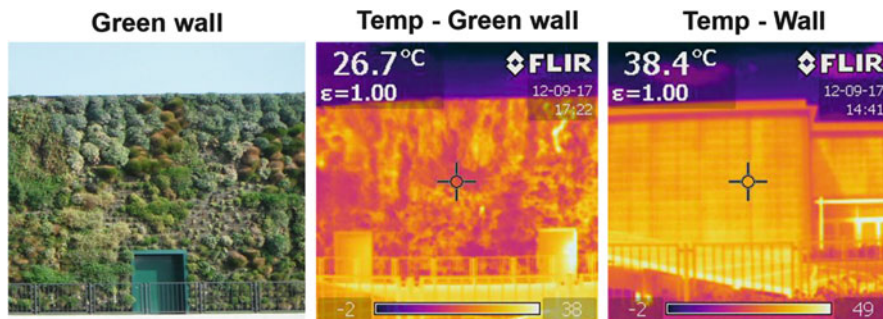
One of the main functions provided by a green roof is the reduction of stormwater runoff from commercial, industrial, and residential buildings. As compared with traditional asphalt or metal roofing, green roofs absorb, store, and reconstitute the rainfall to the atmosphere through evapotranspiration. Consistently, they efficiently act as a stormwater management system, overall reducing peak flow to the storm sewer system [14]. Furthermore, conventional roofing may generally lead to the enrichment of rainwater with a number of pollutants, e.g., lead, zinc, pyrene, and chrysene [74]. Moreover, green roofs have the potential for reducing discharge of pollutants (e.g., nitrogen and phosphorous) due to both substrate microbial processes and plant nutrient uptake. Consistently, when implemented on a city scale, green roofs will efficiently reduce the volume of stormwater entering local waterways resulting in lower volumes, lower water temperatures, and better water quality. This is particularly true in cities where combined sewer systems are adopted: in these conditions, stormwater and untreated human and industrial waste are collected within the same pipes. As a consequence, during rainy periods or snow melting, these systems can become overwhelmed by the volume of water and overflow into nearby waterbodies. This risk, generally referred to as combined sewer overflow (CSO), can efficiently be mitigated by urban green infrastructures, including green roofs [75].

### 3.1.2 Thermal Regulation

In many cities, the adoption of greened infrastructures for their energy and ecological functions is an already established governance policy. By placing a vegetated canopy over and around built structures, the first observed effects are temperature mitigation and reduction of the energy cost associated with air conditioning, especially during summer (Fig. 6).

The indirect cooling effect provided by vegetated structures is determined by a great protective capacity against thermal radiation, lowering the temperature of the buildings' surface [76]. This benefit is a direct consequence of the albedo modification of walls and roofs. Buildings with dark impervious roofs have generally a





**Fig. 6** Analysis conducted with a thermal imaging camera in Bologna (Italy) showing temperature differences between a green and a concrete wall cover (*Source*: Second author)

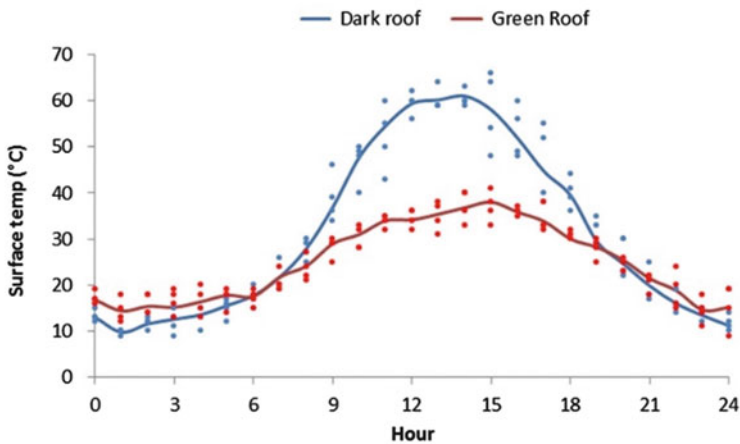
low albedo (Fig. 7), which means higher absorption of solar radiation. This translates into a more intense surface heating, especially when compared to a vegetated canopy. During summertime, this leads to an increase of the day-night heat island effect, energy consumption for indoor artificial cooling, and pollution emission. In European cities, more than 90 % of roofs are dark in color, and the surface of the cover under the sunlight reaches temperatures around 80 °C, with a negative impact on the duration of waterproof insulation [77].

Alternatively, the adoption of greened roofs promotes the conversion of solar energy to transpiration (cooling), as well as the growth of plants. This is particularly the case during summer, given the direct relationship between plant transpiration and solar radiation and temperature (Fig. 8). As a consequence, from both the vegetated cover and the adopted substrate, a thermal insulation is provided.

### 3.1.3 Air Filtering

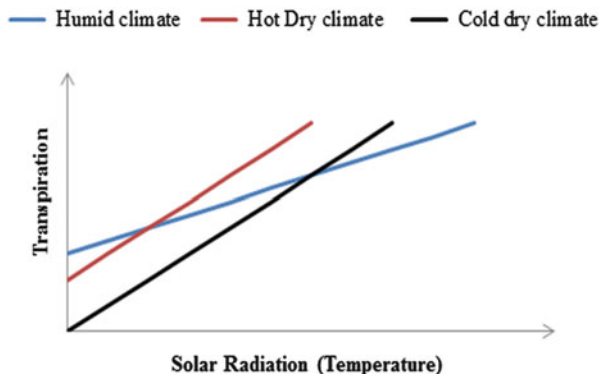
Beyond the previously described effects, the presence of urban structures has a physical modification on the distribution of airborne pollutants – they act as obstacles that exert a frictional force on the atmosphere [3]. Within the urban air profile, the urban canopy, or roughness layer, is the layer of air closest to the surface in cities, extending upward approximately to mean building height (Fig. 9). The mechanical impact of channeling and recirculation of the air turbulence, when combined with emissions of pollutants, leads to a high pollution risk within urban canyons [78, 79]. Vortex recirculation creates an accumulation of pollutants inside the canyon profile. Only a little leakage of flow allows air renewal, and these particular atmospheric conditions cause concerns related to health of the inhabiting population [79].

Air pollutants are naturally present in the atmosphere, although in densely urbanized areas their concentration could be very high. The main air pollutants are represented by gases such as  $\text{NO}_x$ , a wide class of binary molecule compounds of oxygen and nitrogen;  $\text{SO}_x$ , in particular sulfur dioxide; and carbon monoxide

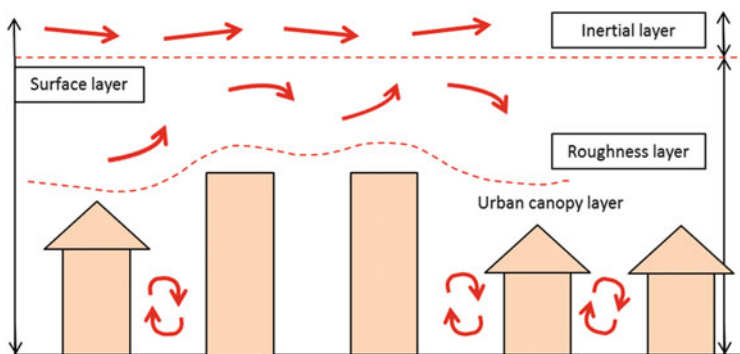


**Fig. 7** Different albedo effects from building surfaces. *Top image* – albedo values for different elements of the urban landscape. *Image below* – surface temperatures of conventional and green roofs, measured during an experimental trial at the Department of Agricultural Sciences at the University of Bologna, Italy (*Source*: Second author)

(CO). In addition, there is a wide amount of airborne aerosols indicated as particulate matter 10 or 2.5 (PM<sub>10</sub> and PM<sub>2.5</sub>) constituted by dust of diameter lower than 10 and 2.5 μm, respectively, as well as dissolved substances. These pollutants can be removed by urban forests, parks, and green covering such as green roofs through different mechanical and biochemical processes. In plants, aerial pollutant

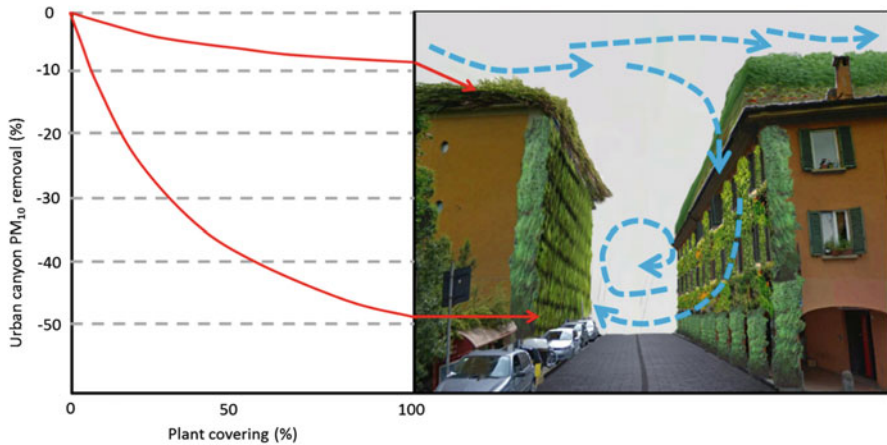


**Fig. 8** Graphical representation of the relationship between solar radiation, temperature, and plant transpiration (*Source*: First and second authors)



**Fig. 9** Graphical representation of the urban profile effects on friction induced in the lower troposphere [3, 80] (Image by second author)

absorption mainly takes place through their entrance from the stomata openings [81] and occurs during the physiological processes of plant photosynthesis and transpiration. These are passive processes, by which gases dispersed in the atmosphere enter into the plant. Once into the plant tissues, some of the dissolved air pollutants such as  $\text{NO}_x$  and  $\text{SO}_x$  are absorbed due to active biochemical reaction and used for plant metabolic processes [82]. Dust components of the airborne aerosol ( $\text{PM}_{10-2.5}$ ) are removed from the atmosphere via electrostatic deposition on the leaf cuticle [83] and successively partially absorbed, washed through runoff, or resuspended in air. Recent studies show that installation of green roofs on buildings' surfaces in urban areas significantly reduces airborne pollutants, contributing indirectly to the increase of the environmental health and well-being of citizens [72]. The qualitative benefit to the low atmosphere is principally associated with alteration of the roughness provided by buildings' facades. Nevertheless, city architecture exacerbates accumulation of particulates within the canyon, and plants



**Fig. 10** Graphical representation of the particulate matter removing capacity of green walls and rooftop gardens [84] (Image by second author)

on roof gardens and walls reduce only in part the presence of pollutants. As shown in Fig. 10, particulate removal efficiency is higher when plants are placed along vertical surfaces of the canyon (green walls), whereas it is lower on flat surfaces (green roofs), although the latter is also dependent on the height of the plants grown [84].

The capacity for reducing dissolved gases and PM is attributed to the increased surface provided by plant canopy that results in increased deposition effects for turbulence impact and interception [85]. This, however, is a relatively new area of study and clearer understanding of the air filtering capacity of such green infrastructures will likely come in the near future [10].

### 3.1.4 Reduction of Noise Pollution

Noise pollution is described as “the introduction of noise in indoor or outdoor environment, such as to cause nuisance or health hazard to humans or the ecosystem” [86]. In urban areas, the level of sound intensity is generally high, because of many combining factors – car traffic, trains, airplanes, public transport, roadwork sites, production activities, etc. Consistently, elevated noise is considered a real source of pollution that causes disturbances as well as changes in social behavior. The reduction of urban noise is an argument of great scientific interest. Different studies have shown that green covers provide an insulating sound barrier because of their capacity to attenuate sound waves. This benefit is determined by a double combination of plants and growing substrate below the canopy level [69]. In general, plant covering can be used in urban areas to control and attenuate noise [87]. Many studies have shown a great potential of the different association of plants in dissipation of noise, especially regarding walls [88] and roofs [69, 89, 90]. According to

these results, green infrastructures placed on walls and roofs may result in a more efficient noise barrier as compared to a traditional surface. In fact, the heterogeneity of plant covering and substrates leads to a greater sound absorption and scattering coefficient, especially lower frequencies. The noise attenuation given by green cover is calculated taking in consideration absorption and scattering effects. In plant covering, the ratio between sound radiation absorbed and total incident one is greater than brick and cement coverings. This effect is principally given by the presence of a stratigraphy able to absorb most of the low frequency waves. The reduction of noise is more effective ( $-5$  to  $-13$  dB) for low-mid frequencies comprised between 50 and 2000 Hz, while just a moderate impact for frequencies higher than 2000 Hz ( $-2$  to  $-8$  dB) [69]. In addition, the stratigraphy of green covering includes growing substrate and other layers needed for the functional anchorage of the system on the surface: this heterogeneous stratigraphy determines absorption of a wide range of waves and scattering of sound [69].

### 3.1.5 Energy Saving

Most energy consumption research concludes that when modifying the albedo of buildings, energy demand is significantly lowered, especially during warmer periods of the year. The mitigation effect has been analyzed with both green covering and white-painted roofs, producing similar results in terms of general benefits for the entire year [91]. Another study conducted specifically on the thermal isolation given by plants on building [92] showed that green roofs provide a reduction of energy required for cooling interior climates. These positive effects were observed on roofs with both extensive and intensive production of edible and ornamental plants. However, similar benefits were observed when building surfaces were painted white, due to the increase in albedo as compared to darker roof colors [93]. Quantification of the energy saved may be obtained by using the equation describing the energy balance. Simplifying the equations of the system, the energy balance ( $qE$ ) has been described as the ratio between energy gained and lost, allowing calculation of energy savings from 32 % up to 100 % in commercial buildings and homes with vegetated covering [91].

Various studies, especially in the sectors of planning and building design, apply the energy equation to estimate energy savings by the utilization of covering surfaces. An analysis conducted on the City of Toronto estimated an energy saving from completely covering the city's buildings. The hypothetical energy balance determined that the annual cost due to energy consumption could be reduced by 58 %, resulting in saving about 20 million USD per year [8]. Another study conducted in New York City addressed the estimation of the energy balance of roofs with low albedo (e.g., dark or black covering) as compared with white and living roofs [93]. Authors estimated the annual cost of energy used to cool the buildings of New York City as 8.5 billion USD. If the surfaces were, instead, painted white (bringing the albedo from 0.1 to 0.7), an economic saving, of around 2.34 billion USD [9], could be obtained. Finally, as the whole city balance is

improved by the presence of green infrastructures, also the global water cycle will benefit, resulting in a lower city water footprint [94].

### **3.2 Environmental Assessment**

In recent years, the adoption of environmental assessment tools for evaluation of city sustainability has been spreading among municipal administrations across the world. Environmental assessment tools attribute an economic value to the benefits connecting the city, environment, and citizenship. These evaluations should take in account various issues such as engineering knowledge, urban design, physics of the troposphere, and biological and social factors of urban life. In order to combine multiple scientific areas, currently, public administrations and research institutions make use of instrumentations and predictive models that allow estimating and planning sustainable land use. Therefore, the mitigation of the adverse environmental effects of urbanization and generation of urban resilience can be planned by implementing appropriate policies to improve the metabolism of the city. In addition it is also possible to reduce, at least partially, adverse effects on the population, food waste production, and energy consumption. Physical models of the atmosphere allow prediction of particulate matter dispersion in the lower layer of the atmosphere and within the urban canyon, whereas geographical information systems (GIS) allow mapping of descriptive data in the urban area. In addition, life cycle analysis (LCA) is widely utilized to study and describe the half-life of a product or process in order to calculate total energy cost, improve environmental performance, and consider multiple factors simultaneously [95]. These analytical tools provided useful information enabling holistic urban environment evaluation that integrates many ecological and social aspects.

One of the main reasons for conducting this analysis is to improve urban management with particular attention to water, energy, and material consumption, microclimate quality, and the effects on the health of citizens. Tools of environmental analysis can provide quantification in terms of energy savings. This, in the long term, may be used to assess the return on investment required for implementation of green infrastructures (e.g., parks, green walls, rooftop gardens, etc.). However, to date, commercial or residential building owners are often reluctant in accepting or selecting greened infrastructures as a solution to many climate/environmental issues, mainly due to elevated start-up costs and uncertainties in maintenance requirements.

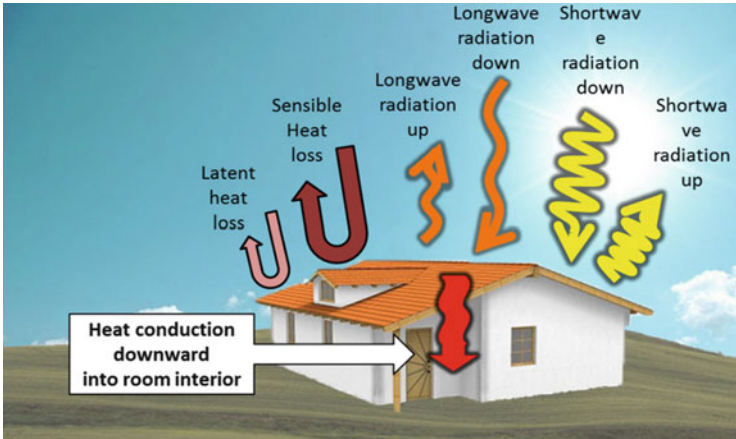
Taking into consideration the whole life cycle of a green roof, different initial and maintenance costs have been recently addressed. It was shown that the cost of extensive green roof (EGR), i.e., shallow substrate roofs, is lower than conventional roofs. On the other hand, intensive green roof (IGR), or deep substrate roof system, presents a higher life cycle cost (LCC) than conventional roofs [95]. The mere analysis of economic figures for installation and maintenance should be further integrated with a series of benefits that a roof garden offers in order to support the

decision for its construction. Throughout the life of a more ecological building, many environmental costs are taken into consideration.

LCA offer a very powerful tool for this evaluation. It examines most of the environmental aspects correlated with the construction of a rooftop garden on a building, taking in consideration primarily initial and running costs but also all the benefits that are brought to the environment, including ecosystem services (e.g., microclimate, air filtering, water regulation, etc.) provided [96]. Many LCA studies, conducted on roof gardens, showed positive environmental performances, including the improvement of food system sustainability whenever agricultural activities were included on the rooftop [15]. Within these kinds of studies, a particular focus was reduction of long-range transport and benefits on urban resilience provided by local food production. Current food supply systems are highly reliant on the global transport/energetic system [97]. LCA tools can be applied in many studies, in order to identify the different streams of energy and matter within the urban system. As the studies have scarcely explored the subject of these innovative green infrastructures, the preliminary steps include data acquisition and creation of the life cycle inventory (LCI), which includes all the factors involved in the cycle. Successively, analysis proceeds with characterization of overall impact, through multiplication of each factor's impacts with the category of impact [98].

### 3.2.1 Analysis for the Energy Balance

Urban resilience is strongly affected by the energy use efficiency of its components [9, 91]. A predictive analytic model for environmental sustainability study allows planning construction and/or renovation of buildings in order to improve the energy class and reduce emissions. These kinds of tools are currently used to calculate the benefits related to energy savings offered by plant covers on building. One of these tools is the energy balance model, an instrument of relatively easy application that allows calculation of the energy flow from inside to outside, or vice versa, in building roof system taking in consideration the different fluxes of energy within the system [99]. Application of the energy balance can help to assess the effect of a roof with vegetated cover in an urban context, comparing it with buildings with conventional roofs, estimating the effect of the heat island effect and energy consumption in buildings, as described by the energy balance model (Fig. 11). The predictive model (Eq. 1) uses seven streams of energy – shortwave radiation downward and upward, longwave radiation downward, longwave radiation emitted upward, sensible heat loss or gain, latent heat loss, and heat conduction downward or upward. The left side of the equation indicates the fluxes of energy into the building from the roof; meanwhile the right side indicates the thermal changing of the roof canopy:



**Fig. 11** Seven fluxes of energy that influence the energy balance model [91] (Image by second author)

$$\begin{aligned}
 & SW_{\text{down}} - SW_{\text{up}} + LW_{\text{down}} - LW_{\text{up}} - Q_{\text{conv}} - Q_{\text{cond}} - Q_{\text{lat}} \\
 & = C_{\text{roof}} \cdot \frac{d}{dt} \left[ \frac{T_{\text{roof}} + T_{\text{ceiling}}}{2} \right] \tag{1}
 \end{aligned}$$

where SW and LW refer, respectively, to shortwave and longwave radiation. The subscripts indicate direction (downward or upward). Latent heat transport ( $Q$ ) is divided between convective (conv), conductive (cond), and latent (lat) terms. On the right-hand side of the equation is the heat capacity coefficient of the roof ( $C_{\text{roof}}$ ), the roof temperature ( $T_{\text{roof}}$ ), and ceiling temperature ( $T_{\text{ceiling}}$ ).

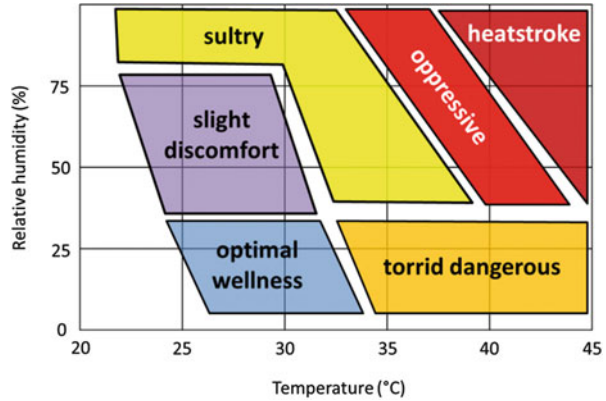
This model has been applied in several studies to monitor the effects of green roofs or roofs with high albedo [9], showing that both solutions reduce the effects of the UHI by reducing city warming induced by thermal solar radiation. The economic investments and maintenance for high-tech and living roofs obviously must be considered, keeping in mind that despite high installation costs, living roofs offer a number of ecosystem services (e.g., water regulation, esthetic value) not provided by white-painted roofs [99].

### 3.2.2 Analysis of the Comfort

The bioclimatic comfort analysis is a statistical procedure used to correlate microclimatic and meteorological parameters with the sensations of comfort or discomfort felt by citizens. A wide range of bioclimatic indices can be adopted for this kind of assessment. Many are based on empiric estimation and can be applied in a range of situations. Some indices fit better in hot or cold conditions, and others are applied in presence of high humidity or wind. The choice is often purely operational and



**Fig. 12** Comfort classes in the urban environment [101] (Image by second author)



linked to the availability of measures of specific atmospheric parameters [100]. The thermo-hygrometric index (THI) [101] is one of the most utilized indexes in analyses of bioclimatic comfort (Eq. 2):

$$THI = AT - (0.55 - 0.0055 \cdot RH) \cdot (AT - 14.5) \quad (2)$$

where THI is the thermo-hygrometric index, AT is air temperature (°C), and RH is relative humidity (%).

Utilizing this equation, a diagram can be produced correlating relative humidity and air temperature. The resulting patches indicate the comfort physiologic classes for human life within the studied environment (Fig. 12). From the analysis of the comfort classes, it is possible to observe that a THI between 15 and 20 determines a condition of optimal comfort, while when THI rises over 20, different classes of physiological stress are encountered. In conclusion, the tools of environmental analysis, such as the bioclimatic comfort, allow modeling of urban microenvironmental characteristics. These possibilities are very useful during the design phases of the city and help public administrations to maximize the economical, physical, and climatic conditions of people that live and work within urban areas.

## 4 Conclusions

Installing and maintaining green roofs contribute to many aspects of urban sustainability, especially in urban water management strategies. Furthermore, urban water consumption is increasingly linked to resource conservation (soil, water, energy, air). Achieving better efficiencies in green roofs irrigation is a challenge that authorities, municipalities, and city communities are facing. Therein, rules and interactions to the improvement of governance must take into account natural and socioeconomic resources.

**Table 6** Available options for the improvement of irrigation efficiency [102]

Subject	Options
Agronomy	Crop management to enhance rainfall capture or reduce soil evaporation (mulching, plant spacing); drought-resistant species/varieties; consideration of seasonal variation in water availability when defining grown species. Crop rotations
Engineering	Efficient irrigation systems, watering uniformity, rainfall capture. Waste-water treatment. Drainage
Management and audits	Demand-based irrigation scheduling; deficit irrigation techniques; preventive management against equipment failures. Use of sensors. Irrigation and drainage system auditing
Policy	Participatory water management; water pricing and legal incentives to reduce water use, penalties for inefficient use; training and educational opportunities for learning newer and advanced techniques. Promote methodological tools as Decision Support Systems and Benchmarking or Expert Systems, to integrate compromising solutions to improve farming performance concerning green roof multifunctionality (e.g., water use, energy, climate, agronomic, economic issues)

Optimal irrigation management is obtained by combining interdisciplinary issues. Table 6 provides a brief presentation of suitable agronomic, engineering, management, and policy solutions [102]. Suitable agronomic solutions include some important decisions helpful in improving urban irrigation efficiency. A basic agronomy management action is to establish crop rotations. This option is a proper measure to reduce problems in the substrate-plant system related to pest, diseases, and nutrients. Constraints in urban crop management may be due to shallow root systems and varying plant species and water requirements in close proximity [22]. Many tables from irrigation handbooks may be used to access information concerning most plants. More specific indications may come from general urban cultivation guidelines and manuals (directly addressing adoption of grass, shrubs, trees, annual crops, ornamental horticulture, vegetables, etc.). The substrate physical characterization is a crucial action needed to develop adequate irrigation and drainage systems, which shall ensure the infiltration limitations are controlled. In this way, the potential for waterlogging or runoff/erosion problems, mainly related to heavy rainfall or water application, is reduced. For a green roof design with a microsprinkler irrigation system, it is also important that the water losses caused by climatic factors, as wind drift or soil evaporation, are efficiently controlled. If pressurized irrigation systems are properly designed and operated, the application efficiency and uniformity must reach 80–90 %. Many regions around the globe present climate changes, leading to rainfall decrease and/or seasonal anomalies and to temperatures increase. Those phenomena reinforce the need for better management guidelines and application of smart technologies in irrigation, like soil moisture and rain sensors, automation switches, or wireless control, which will likely improve water use efficiency [22]. Currently, smart controllers equipped with ET sensors or connected to ET information providers constitute a cutting-edge technology.

Regenerated water irrigation can make a significant contribution to reducing water demand, recycling nutrients, improving soil health, and cutting the amount of pollutants discharged into the waterways. Another advantage of this resource – when compared to rainwater – is that it can be available in almost stable quantity through the year and specifically during summer period where there is need for irrigation. However, relevant systems must be carefully managed to protect the environment and public health.

## References

1. World Health Organisation (2015) Global Health Observatory (GHO) data – urban population growth. Retrieved June 2015 from [http://www.who.int/gho/urban\\_health/situation\\_trends/urban\\_population\\_growth\\_text/en/](http://www.who.int/gho/urban_health/situation_trends/urban_population_growth_text/en/)
2. Naishi L, Zangang Z, Liuwei Z (1998) An analytical study on the urban boundary layer. *Adv Atmos Sci* 15(2):258–266
3. Britter RE, Hanna SR (2003) Flow and dispersion in urban areas. *Annu Rev Fluid Mech* 35: 469–496
4. Bonafè G (2006) Microclima urbano: impatto dell'urbanizzazione sulle condizioni climatiche locali e fattori di mitigazione. ARPA Emilia-Romagna. Retrieved June 2015 [http://www.arpa.emr.it/cms3/documenti/\\_cerca\\_doc/meteo/ambiente/bonafe\\_report\\_meteo\\_urbana.pdf](http://www.arpa.emr.it/cms3/documenti/_cerca_doc/meteo/ambiente/bonafe_report_meteo_urbana.pdf)
5. Henderson SB, Beckerman B, Jerrett M, Brauer M (2007) Application of land use regression to estimate long-term concentrations of traffic-related nitrogen oxides and fine particulate matter. *Environ Sci Tech* 41(7):2422–2428
6. White KS et al (2001) Technical summary, climate change 2001: impacts, adaptation and vulnerability. In: McCarthy JJ, Canziani OF, Leary NA, Dokken DJ, White KS (eds) *Climate change 2001: impacts, adaptation and vulnerability*. United Nations' Intergovernmental Panel on Climate Change (IPCC) Cambridge University Press, Cambridge, pp 19–73
7. Koppe C, Kovats S, Jendritzky G, Menne B (2004) Health and global environmental change; heat-waves: risks and responses, series no. 2, energy, environment and sustainable development. World Health Organization, Copenhagen
8. Banting D, Doshi H, Li J, Missions P, Au A, Currie BA, Verrati M (2005) Report on the environmental benefits and costs of green roof technology for the city of Toronto. City of Toronto and Ontario Centres of Excellence – Earth and Environmental Technologies (OCE-ETech). Retrieved May 2015 <http://nestabode.com/wp-content/uploads/2014/03/fullreport103105.pdf>
9. Rosenzweig C, Gaffin S, Parshall L (2006) Green roofs in the New York metropolitan region: research report. Columbia University Center for Climate Systems Research and NASA Goddard Institute for Space Studies, New York, p 59. Retrieved April 2015 [http://pubs.giss.nasa.gov/docs/2006/2006\\_Rosenzweig\\_et\\_al\\_1.pdf](http://pubs.giss.nasa.gov/docs/2006/2006_Rosenzweig_et_al_1.pdf)
10. Currie BA, Bass B (2008) Estimates of air pollution mitigation with green plants and green roofs using the UFORE model. *Urban Ecosyst* 11(4):409–422
11. Speak AF, Rothwell JJ, Lindley SJ, Smith CL (2012) Urban particulate pollution reduction by four species of green roof vegetation in a UK city. *Atmos Environ* 61:283–293
12. Dietz ME (2007) Low impact development practices: a review of current research and recommendations for future directions. *Water Air Soil Pollut* 186:351–363, <http://citeseerx.ist.psu.edu/viewdoc/download?doi=10.1.1.454.2519&rep=rep1&type=pdf>
13. Berndtsson CJ (2010) Green roof performance towards management of runoff water quantity and quality: a review. *Ecol Eng* 36(4):351–360

14. Gregoire B, Clausen J (2011) Effect of a modular extensive green roof on stormwater runoff and water quality. *Ecol Eng* 37(6):963–969
15. Orsini F, Gasperi D, Marchetti L, Piovene C, Draghetti S, Ramazzotti S, Bazzocchi G, Gianquinto G (2014) Exploring the production capacity of rooftop gardens (RTGs) in urban agriculture: the potential impact on food and nutrition security, biodiversity and other ecosystem services in the city of Bologna. *Food Secur* 6(6):781–792
16. Dziegielewski B (2006) Interdisciplinary in IWRA. *International Water Resources Association*. *Water Int* 31(2):143–144
17. UN Food Agriculture Organisation (1985) Guidelines: land evaluation for irrigated agriculture. *FAO soils bulletin* 55. FAO Land and Water Development Division, Rome
18. UN Food Agriculture Organisation (2007) Handbook on pressurized irrigation techniques. FAO Water Development and Management Unit and International Programme for Technology and Research in Irrigation and Drainage (IPTRID), Rome
19. US Department of Agriculture Natural Resources Conservation Service (2008) National engineering handbook: part 652, irrigation guide. NRCS, Washington, DC, <http://directives.sc.egov.usda.gov/viewerFS.aspx?hid=21431>
20. World Health Organisation (2006) Guidelines for the safe use of wastewater, excreta and greywater. Retrieved June 2015 [http://www.who.int/water\\_sanitation\\_health/wastewater/gsuww/en/](http://www.who.int/water_sanitation_health/wastewater/gsuww/en/)
21. Agritech (ed) (1990) 5th International Conference on Irrigation: proceedings, Tel-Aviv, Israel, 26–27 March. Agritech Israel, p 326
22. Connellan GJ (2004) Evaluating the performance of urban irrigation. In: Proceedings of NZWWA conference, Christchurch, October
23. Pijnappels M, Dietl P (2013) Adaptation inspiration BookCIRCLE-2. University of Lisbon, Lisbon, pp 154–157
24. UN Food Agriculture Organisation/Ayers RS, Westcot DW (1989) Water quality for agriculture. FAO irrigation and drainage paper #29. FAO, Rome
25. Summer M (ed) (2000) Handbook of soil science. CRC Press, New York, p 2148
26. EEA (European Environment Agency) (2012) Climate change, impacts and vulnerability in Europe 2012. An indicator-based report. European Environment Agency Report, EEA report 12/2012, Copenhagen
27. OECD (Organisation for Economic Co-operation and Development) (1999) Environmental indicators for agriculture. Volume 2: issues and design. The York workshop. OECD Publications, Paris
28. EEA (European Environment Agency) (2013) Adaptation in Europe. Addressing risks and opportunities from climate change in the context of socio-economic developments. European Environment Agency report, EEA report 3/2013, Copenhagen
29. Dunnett N, Gedge D, Little J, Snodgrass E (2011) Small green roofs: low-tech options for greener living. Timber Press Portland, London, p 256
30. Mourão I (2013) Horticultura Social e terapêutica: contexto. In: Horticultura Social e Terapêutica. Publindustria, Edições Técnicas. Porto.- Mourão, I.M.; L.M. Brito (coord.)
31. OECD (Organisation for Economic Co-operation and Development) (2008) Towards sustainable agriculture. OECD contribution to the United Nations. Commission on sustainable development (UNCSD 16). Secretary General of the OECD, New York
32. Kolberg S, Berbel J (2011) Defining rational use of water in Mediterranean irrigation. *Options Mediterr* A-98
33. Moeller A (2012) Identify soil moisture status more accurately than ever before! *Michigan State Univ Green Section Rec* 50(9):1–5
34. Martin DL, Kranz WL, Thompson AL, Liang H (2012) Selecting sprinkler packages for center pivots. *Trans ASABE* 55(2):513–523
35. Al-kaisi M, Licht M (2004) Evaluating soil moisture before field preparation and planting. *Integrated Crop Management Newsletter*. Iowa State University, Iowa

36. Luz PB (2013) Guia para a avaliação e seleção de sistemas de rega. Programa de Investigação e de Formação Pós-Graduada. Provas de Habilitação para o exercício de funções de coordenação científica. 15 de janeiro de 2013. INIAV, p 86
37. Keller J, Bliessner RD (1990) Sprinkler and trickle irrigation. Van Nostrand Reinhold, New York
38. Singer M, Munns D (1999) Soils: an introduction, 4th edn. Prentice-Hall, London, p 464
39. Oberndorfer E, Lundholm J, Bass B, Coffman R, Doshi H, Dunnet N, Gaffin S, Kohler M, Liu K, Rowe B (2007) Green roofs as urban ecosystems: ecological structures, functions and services. *BioScience* 57(10):823–833
40. De Pascale S, Orsini F, Pardossi A (2013) Irrigation water quality for greenhouse horticulture. In: Quaryoti M, Baudoin W, Nono Womdin R, Leonardi C, Hanafi A, De Pascale S (eds) Guidelines on GAP for greenhouse horticulture in the Mediterranean region. FAO paper, AGP series, vol 217. FAO-UN, Rome, pp 169–204
41. Antoniou G, Kathijotes N, Spyridakis DS, Angelakis AN (2014) Historical development of technologies for water resources management and rainwater harvesting in the Hellenic civilizations. *Int J Water Resour Dev* 30(4):680–693
42. Chang NB, Rivera BJ, Wanielista MP (2011) Optimal design for water conservation and energy savings using green roofs in a green building under mixed uncertainties. *J Clean Prod* 19(11):1180–1188
43. Goyal MR (ed) (2015) Water and fertigation management in micro irrigation. CRC Press, Boca Raton, p 356
44. Irrigation Association (2007) Landscape irrigation auditor. Fairfax
45. University of California Cooperative Extension and California Department of Water Resources (2000) A guide to estimating irrigation water needs of landscape plantings in California – the landscape coefficient method and WUCOLS III (WUCOLS is the acronym for Water Use Classifications of Landscape Species). Retrieved January 2013 from: <http://www.water.ca.gov/wateruseefficiency/docs/wucols00.pdf>
46. California Department of Public Health (CDPH) (2014) Statutes Related to Recycled Water & the California Department of Public Health. §116815, pp 20–21
47. Greek State (2013) Joint Ministerial Decision (JMD) 145116/2011, Governmental Gazette (GG) B 354 8/3/2011 + JMD 191002/2013, GG B' 2220 9/9/2013 Amendment to 354/2011 (in Greek)
48. BSI Group (2013) BS 8515:2009 + A1:2013: rainwater harvesting systems – code of practice, p 64
49. Sanz B, Gawlik M (2014) Water reuse in Europe. A synoptic overview. Relevant guidelines, needs for and barriers to innovation. Joint Research Center (JRC) Science and Policy Reports. European Commission. Retrieved June 2015 <http://publications.jrc.ec.europa.eu/repository/bitstream/JRC92582/lb-na-26947-en-n.pdf>
50. Harivandi MA (2012) Irrigating turfgrasses with municipal reclaimed water. *Acta Horticult* 938:95–103
51. Yu ZLT, Rahardianto A, DeShazo JR, Stenstrom MK, Cohen Y (2013) Critical review: regulatory incentives and impediments for onsite graywater reuse in the United States. *Water Environ Res* 85(7):650–662
52. Ayers RS, Westcot DW (1994) Water quality for agriculture. FAO irrigation and drainage paper 29, Rev. 1, Reprinted 1994. Food and Agricultural Organization, Rome
53. Niu G, Cabrera RI (2010) Growth and physiological responses of landscape plants to saline water irrigation: a review. *Hortic Sci* 45(11):1605–1609
54. Rowe DR, Abdel-Magid IM (1995) Handbook of wastewater reclamation and reuse. CRC Lewis, Boca Raton, p 576
55. Haas CN, Rose JB, Gerba CP (1999) Quantitative microbial risk assessment. Wiley, New York, p 464

56. Hanjra MA, Blackwell J, Carr G, Zhang F, Jacksona TM (2012) Wastewater irrigation and environmental health: implications for water governance and public policy. *Int J Hyg Environ Health* 215:255–269
57. US Environmental Protection Agency (2004) Guidelines for water reuse. EPA/625/R-04/108. Washington, DC. Retrieved July 2015 <http://water.epa.gov/aboutow/owm/upload/Water-Reuse-Guidelines-625r04108.pdf>
58. Allen L, Christian-Smith J, Palaniappan M (2010) Overview of greywater reuse: the potential of greywater systems to aid sustainable water management. Pacific Institute. Retrieved June 2015 [http://www.pacinst.org/wp-content/uploads/sites/21/2013/02/greywater\\_overview3.pdf](http://www.pacinst.org/wp-content/uploads/sites/21/2013/02/greywater_overview3.pdf)
59. Alfiya Y, Damti O, Stoler-Katz A, Zoubi A, Shaviv A, Friedler E (2012) Potential impacts of on-site greywater reuse in landscape irrigation. *Water Sci Technol* 65(4):757–764, [http://gwri-ic.technion.ac.il/pdf/gwri\\_abstracts/2012\\_1/6.pdf](http://gwri-ic.technion.ac.il/pdf/gwri_abstracts/2012_1/6.pdf)
60. Lambrinos JG (2015) Water through green roofs. In: Sutton R (ed) *Green roof ecosystems*, vol 223, Ecological studies. Springer, Switzerland, pp 81–105
61. Lazarova V, Bahri A (eds) (2005) *Water reuse for irrigation: agriculture, landscapes, and turf grass*. CRC Press, Boca Raton, p 432
62. Lockett K (2009) *Green roof construction and maintenance*. International Code Council. McGraw-Hill, New York
63. European Commission Environment (1991) The urban wastewater treatment directive (91/271/EEC). [http://ec.europa.eu/environment/water/water-urbanwaste/index\\_en.html](http://ec.europa.eu/environment/water/water-urbanwaste/index_en.html). Accessed June 2015
64. European Commission Environment (1998) Amending Directive 91/271/EEC (98/15/EEC). <http://eur-lex.europa.eu/legal-content/EN/TXT/PDF/?uri=CELEX:31998L0015&from=EN>. Accessed June 2015
65. Norma Portuguesa 4434 (NP-4434) (2005) Reutilização de águas residuais urbanas tratadas para rega
66. DEFRA (2012) Waste water treatment in the United Kingdom. Implementation of the European Union Urban Waste Water Treatment Directive – 91/271/EEC. PB13811, p 49. Available online at: [www.defra.gov.uk/environment/quality/water/sewage/sewage-treatment](http://www.defra.gov.uk/environment/quality/water/sewage/sewage-treatment)
67. Zucaro R, Rago C, Vollaro M (2012) Valutazione tecnico-economica delle potenzialità di riutilizzo irriguo dei reflui depurati: il caso della Valpadana. In Congress papers (no. 124115). Italian Association of Agricultural and Applied Economics (AIEAA)
68. National Water Quality Management Strategy (2000) Guidelines for sewerage systems – use of reclaimed water. Retrieved July 2015 <http://www.environment.gov.au/resource/guidelines-sewerage-systems-use-reclaimed-water>
69. Connelly M, Hodgson M (2008) Sound transmission loss of green roofs, session 1.5 thermal and acoustical performance of green roofs. Greening Rooftops for Sustainable Communities conference, awards 6 trade show, Baltimore, April 30 to May 2
70. Eumorfopoulou EA, Kontoleon K (2009) Experimental approach to the contribution of plant covered walls to the thermal behavior of building envelopes. *Build Environ* 44(5):1024–1038
71. Getter KL, Rowe DB, Robertson GP, Cregg BM, Andresen JA (2009) Carbon sequestration potential of extensive green roofs. *Environ Sci Technol* 43(19):7564–7570
72. Nowak DJ, Crane DE, Stevens JC (2006) Air pollution removal by urban trees and shrubs in the United States. *Urban For Urban Green* 4(3–4):115–123
73. Yang J, Yu Q, Gong P (2008) Quantifying air pollution removal by green roofs in Chicago. *Atmos Environ* 42:7266–7273
74. Van Metre PC, Mahler BJ (2003) The contribution of particles washed from rooftops to contaminant loading to urban streams. *Chemosphere* 52:1727–1741
75. Spatari S, Yu Z, Montalto FA (2011) Life cycle implications of urban green infrastructure. *Environ Pollut* 159(8):2174–2179
76. Wong NH, Chen Y, Ong CL, Sia A (2003) Investigation of thermal benefits of rooftop garden in the tropical environment. *Build Environ* 38(2):261–270

77. Santamouris M (2014) Cooling the cities – a review of reflective and green roof mitigation technologies to fight heat island and improve comfort in urban environments. *Sol Energy* 103:682–703
78. Jeong SJ, Andrews MJ (2002) Application of the k-epsilon turbulence model to the high Reynolds number skimming flow field of an urban street canyon. *Atmos Environ* 36: 1137–1145
79. Kastner-Klein P, Berkowicz R, Britter R (2004) The influence of street architecture on flow and dispersion in street canyons. *Meteorol Atmos Phys* 87(1–3):121–131
80. Oke TR (1987) *Boundary layer climates*, 2nd edn. Methuen, New York
81. Winner WE (1994) Mechanistic analysis of plant responses to air pollution. *Ecol Appl* 4(4): 651–661
82. Baldocchi D, Hicks B, Camara P (1987) A canopy stomatal resistance model for gaseous deposition to vegetated surfaces. *Atmos Environ* 21:91–101
83. Prajapati SK (2012) Ecological effect of airborne particulate matter on plants. *Environ Skep Crit* 1(1):12–22, <http://www.taccire.suanet.ac.tz:8080/xmlui/handle/123456789/159>
84. Pugh T, MacKenzie AR, Duncan Whyatt J, Hewitt CN (2012) Effectiveness of green infrastructure for improvement of air quality in urban street canyons. *Environ Sci Tech* 46(14):7692–7699
85. Petroff A, Mailliat A, Amielh M, Anselmet F (2008) Aerosol dry deposition on vegetative canopies. Part I: review of present knowledge. *Atmos Environ* 42:3625–3653
86. Stansfeld SA, Matheson MP (2003) Noise pollution: non-auditory effects on health. *Br Med Bull* 68(1):243–257
87. Pittaluga I, Schenone C, Palla A, Lanza GL (2009) Le prestazioni acustiche del verde pensile: assorbimento sonoro di coperture di diversa configurazione. *Convengno “2a giornata di studio sull’acustica ambientale”*, Arenzano
88. Kang J (2007) *Urban sound environment*. CRC Press, Boca Raton, p 296
89. Van Renterghem T, Botteldooren D (2008) Numerical evaluation of sound propagating over green roofs. *J Sound Vib* 317(3–5):781–799, <http://users.ugent.be/~tvrenter/publicaties/greenroofs.pdf>
90. Van Renterghem T, Botteldooren D (2009) Reducing the acoustical façade load from road traffic with green roofs. *Build Environ* 44(5):1081–1087, <http://www.greenroofresearch.co.uk/acoustic/Green%20roof.pdf>
91. Alexandri E, Jones P (2006) Temperature decreases in an urban canyon due to green walls and green. *Build Environ* 43(4):480–493
92. Del Barrio EP (1998) Analysis of the green roofs cooling potential in buildings. *Energy Build* 27(2):179–193
93. Rosenzweig C, Hillel C (1998) *Climate change and the global harvest*. Oxford University Press, New York, p 324
94. Getter KL, Rowe DB (2006) The role of extensive green roofs in sustainable development. *Hortic Sci* 41(5):1276–1285
95. Wong NH, Tay SF, Wong R, Ong CL, Sia A (2003) Life cycle cost analysis of rooftop gardens in Singapore. *Build Environ* 38:499–509
96. Kosareo L, Ries R (2007) Comparative environmental life cycle assessment of green roofs. *Build Environ* 427(7):2606–2613
97. The European Environment Agency (2010) *State and outlook 2010*. EEA, Copenhagen. Accessed June 2015
98. International Organization for Standardization (2006) *Life cycle assessment –principles and framework*. ISO publication 14040. Geneva
99. Acks K, Rosenzweig C, Gaffi S, Parshall L (2006) A framework of green roof cost-benefit analysis: initial estimates. In:0020Green roofs in the New York Metropolitan region (eds). NASA/Goddard Institute for Space Studies and Columbia University Center for Climate Systems Research. Retrieved June 2015 <http://www.statisticstutors.com/articles/debrat-green-roofs.pdf>

100. Georgiadis T (2015) Isola di calore urbana e progettazione del comfort. In REBUS RENovation of public Buildings and Urban Spaces. Technical report for Regione Emilia-Romagna 1(3):1–19 [http://territorio.regione.emilia-romagna.it/paesaggio/cooperazione-territoriale-e-paesaggio/REBUS13progettazionecomfort.pdf/at\\_download/file/REBUS+1-3+progettazione+comfort.pdf](http://territorio.regione.emilia-romagna.it/paesaggio/cooperazione-territoriale-e-paesaggio/REBUS13progettazionecomfort.pdf/at_download/file/REBUS+1-3+progettazione+comfort.pdf)
101. Thom E (1959) The discomfort index. *Weatherwise* 12:57–60
102. Howell TA (2001) Enhancing water use efficiency in irrigated agriculture. *Agron J* 93(2): 281–289



# Modern Urban Rainwater Harvesting Systems: Design, Case Studies, and Impacts

Sarah Sojka, Tamim Younos, and David Crawford

## Contents

1	Introduction .....	210
2	Modern Rainwater Harvesting Systems .....	211
3	Rainwater Harvesting System Design .....	212
3.1	Rooftop Characteristics .....	213
3.2	Prestorage Treatment .....	215
3.3	Storage Tank .....	216
3.4	Post-storage Water Quality and Treatment .....	217
4	Rainwater Harvesting Selected Case Studies .....	220
5	Rainwater Harvesting Impacts .....	223
5.1	Stormwater Runoff Management .....	223
5.2	Potable Water Saving and Energy Conservation .....	225
5.3	Economic Benefits .....	226
5.4	Life Cycle Assessment .....	227
6	Conclusions .....	229
	References .....	229

**Abstract** The popularity of rainwater harvesting has increased in recent years due to increasing demands on strained water supplies and infrastructure and increasing awareness of the benefits of green stormwater infrastructure. Active rainwater harvesting systems, in which the water is captured and stored in a tank or similar container, can be a major source of water in urban areas supplying non-potable end uses such as irrigation, toilet flushing, and cooling towers. Harvested rainwater is also used for potable uses commonly in developing nations and rarely in developed nations. The benefits of rainwater harvesting systems extend beyond water

---

S. Sojka (✉)  
Randolph College, Lynchburg, VA, USA  
e-mail: [ssojka@randolphcollege.edu](mailto:ssojka@randolphcollege.edu)

T. Younos  
Green Water-Infrastructure Academy, Washington, DC, USA

D. Crawford  
Rainwater Management Solutions, Inc., Salem, VA, USA

conservation to include alleviating the impact of stormwater runoff on surface waters, contributing to groundwater preservation, and reducing dependency on utility potable water and consequently energy conservation. This chapter focuses on active rainwater harvesting systems design and discusses environmental impacts and economic and life cycle assessment of rainwater harvesting systems. The chapter concludes with recommendations on future research needs.

**Keywords** Alternative water supply • Decentralized systems • Energy conservation • Green infrastructure • Low-impact development • Potable water saving • Rainwater harvesting

## 1 Introduction

Rainwater harvesting systems are often viewed as a “new” technology but are in fact an ancient practice. In areas with scarce water resources around the world, early civilizations used farming practices to direct surface water to crops (passive rainwater harvesting) and stored collected rainwater in cisterns and similar storage vessels to use for household and other uses (active rainwater harvesting). An overview of these rainwater harvesting systems can set the context for examining modern rainwater harvesting systems.

Rainwater harvesting played an important role in water supply in early civilizations in the Mediterranean. Beginning about 2500 BCE, the Minoan civilization collected rainwater via terra cotta pipes to store in cisterns to cope with the dry Mediterranean summers [1], and water supply for the Palace in Phaistos, a major center of wealth and power in the Minoan civilization, was collected from roofs and courtyards and stored in cisterns [2]. Ancient Greeks typically used harvested rainwater for uses other than drinking but recognized the importance of rainwater as a drinking water source during times of drought and war [2]. In the Aegean Islands starting in the fifth century BCE, harvested rainwater was used for public and private buildings, including places of worship, and to ensure water security during battle, rainwater was stored in fortresses [1]. Contamination of local water supplies, as in Pompeii, also increased reliance on rainwater harvesting as a water source [3]. While the common perception of the ancient Roman water system focuses on aqueducts, rainwater harvesting systems (often associated with individual homes) provided much of the water for drinking and bathing [2]. In addition, rainwater harvesting systems dating back to approximately 300 BCE have been found in northwestern Egypt [4]. In the Negev desert, farmers raked rocks out of the hillsides to encourage the water to run faster to cisterns which are still used today [5]. Rainwater harvesting systems remained common throughout the Mediterranean at least through the Middle Ages and continued to increase in sophistication. In

Venice, some rainwater harvesting systems built around 1200–1670 even filtered the water (through a sand filter) before it was stored in a tank [1].

While Mediterranean cisterns are the most researched, rainwater harvesting systems were common in most arid and semiarid regions. For example, the Mayans relied heavily on harvested rainwater, and in Mayan cities, such as Tikal, rainwater stored in large tanks provided the primary source of water, and later rainwater harvesting also served as a major source of water in Xochicalco [1]. These rainwater harvesting practices arose in response to local climate and can provide guidance to modern civilizations facing climate change [6]. In modern times, rainwater harvesting systems have spread from arid and semiarid regions and have become a prominent component of green building and low-impact development (LID) worldwide.

## 2 Modern Rainwater Harvesting Systems

The spread of rainwater harvesting systems stems from increasing demands on water supplies from increasing population, particularly in urban areas, diminishing freshwater supplies and a lack of access to safe water for many global communities. According to the World Health Organization (WHO) and UNICEF, access to improved water sources has increased around the world. However, as urban population has increased, reaching 54 % of global population by 2015, the actual number of urban inhabitants without access to an improved water source has increased, though access is still far greater than in rural areas [7]. In addition to lack of access to improved water sources, large portions of the global population face significant water shortages. Without climate change mitigation, more than 50 % of the world's population will experience severe water scarcity (based on basin or grid level water scarcity) by 2050 [8]. Globally, groundwater depletion is estimated at 113 km<sup>3</sup>/year (2000–2009) with 15 % of groundwater originating from nonrenewable sources [9]. Against this background of water supply issues, cities face flooding, overburdened water supply and stormwater systems, and heightened awareness of the impacts from runoff.

Both passive and active rainwater harvesting systems can reduce demand on surface and groundwater supplies, though they meet different needs. Passive rainwater harvesting systems capture water from landscape depressions and provide water to plants through overland flow. In active rainwater harvesting systems, the water is captured from rooftops and used in-building to meet water demands such as toilet flushing, laundry and cooling, and outdoors for uses such as landscape and urban agriculture, fountains, and other needs. In many developing and island countries, rainwater is used as a drinking water source, but in developed countries, there are few cases of using harvested rainwater for potable uses. Because of the prevalence of indoor demands in urban areas, this chapter focuses on active rainwater harvesting systems.

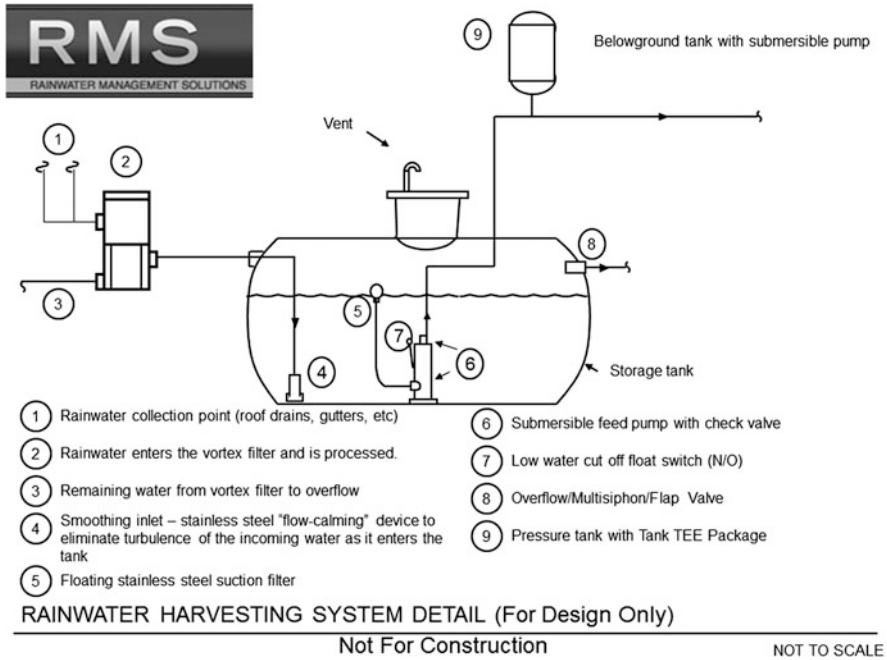
Rainwater can be collected from a range of surfaces that include rooftops, roads, lawns, and parking areas. However, ground-level surfaces are usually impacted by pet waste, trash, motor oil, and other pollutants which can significantly affect the quality of captured rainwater. In addition, in cold regions, salt is often used for ice melting and removal during winter which can be washed from roadways, parking lots, and sidewalks into rainwater capture systems. Saltwater is unsuitable for irrigation because of its potential damage to plants and for indoor use because of its potential damage to plumbing components. For these reasons, at present, rainwater runoff from building rooftop surfaces is the preferred source for rainwater harvesting systems.

Runoff from roof surfaces can provide a substantial volume of water. Globally, roofs are 27.767 % of surface area in urban areas, which cover  $6.6 \times 10^{11}$  m<sup>2</sup> of land surface [10]. Assuming 90 % capture, 1 cm of rainfall on these roof surfaces would produce  $1.6 \times 10^9$  m<sup>3</sup> of harvested rainwater. For comparison, the New York City Department of Environmental Protection (NYC-DEP) supplies  $4.3 \times 10^6$  m<sup>3</sup> of water per day to New York City (USA) and some customers outside the city [11]. One centimeter of rainfall on all urban rooftops could then more than supply the water demands for New York City for 1 year. Because of the spatial heterogeneity in precipitation, the global average precipitation cannot be used to accurately predict the total runoff available from global urban roofs. However, given a global average precipitation of 1.03 m in 2014 [12], the potential global significance of rooftop rainwater harvesting is clear.

A modern rainwater harvesting system is considered a holistic decentralized water infrastructure because of its multidimensional benefits in urban settings [13]. These benefits include alleviating the impact of stormwater runoff on surface waters, contributing to groundwater preservation, and reducing dependency on utility potable water and consequently energy conservation. This chapter focuses on active rainwater harvesting system design, typical case studies, and environmental and economic impacts of rainwater harvesting systems.

### 3 Rainwater Harvesting System Design

The design of a rainwater harvesting system affects its environmental impacts and economic benefits. Modern rainwater harvesting system design for urban settings has evolved over time. Published standards and guidelines include but are not limited to the EPA LID Center [14], UNEP Rainwater [15], Virginia Rainwater Harvesting Manual [16], Texas Rainwater Harvesting Manual [17], ARCSA/ASPE/ANSI 63-2013 Rainwater Catchment Systems, and Plumbing Engineering & Design Standard [18]. In 2015, the American Society of Plumbing Engineers (ASPE) and the American Rainwater Catchment Systems Association (ARCSA) jointly developed and published the American National Standard on stormwater harvesting system design for direct and indirect end-use applications [19].



**Fig. 1** Schematic of a modern rainwater harvesting system with underground storage (*Source:* Rainwater Management Solutions)

Major components of rainwater harvesting system design are discussed below. At a minimum, urban rainwater harvesting systems include a catchment area (rooftop), piping, and a storage tank. Most modern rainwater harvesting systems also include a filter before the storage tank, additional water treatment (typically installed after the storage tank), and a pump (Fig. 1). Additional water treatment, depending on the end use of the water, could be added to the system, typically after the pressure tank.

### 3.1 Rooftop Characteristics

Roof surface characteristics can significantly impact the quality of harvested rainwater. For example, roofing materials can be a source of contaminants such as heavy metals. In a controlled study comparing three roofing materials with and without lead flashing, the quality of all rainwater samples collected from the model roofs with lead flashing far exceeded acceptable drinking water standards and recreational water standards for lead, with the majority of the lead occurring in dissolved form [20]. Cadmium and zinc have been found in particulate runoff from metal roofs, while lead has been found in runoff from asphalt shingle roofs [21] and

galvanized metal roofs [22]. Mercury may also be released from asphalt shingles [21]. In addition, many roofing materials are treated with biocides or similar to deter algal growth and these biocides can leach into roof runoff [23]. Polycyclic aromatic hydrocarbons (PAHs) have also been found in runoff from a variety of roof materials [24, 25], but surprisingly, asphalt shingles have not been found to supply PAHs [26].

The age of the roofing material impacts the amount of leaching, though the impact on runoff quality is not consistent. Chang et al. [22] found that zinc concentration in runoff from aged wood shingle roofs was lower than the concentration in runoff in new wood shingle roofs. However, results from study roofs indicate that roofing materials can be long-term sources of pollutants. Clarke et al. [27] and Adeniyi and Olabanji [28] found that contaminants from a range of roofing materials increased as the roof aged. In leaching studies, a range of roof materials including asphalt shingles, fake slate roofing shingles, and galvanized metal were all sources of lead, zinc, iron, and copper [27]. While these leaching studies represent a worst-case scenario and likely overestimate the quantity of contaminants mobilized in typical rainfall events, they demonstrate the potential of contamination. The extent of leaching from roof materials is affected by the pH of the rainfall [29]. In addition, the interaction of the rainwater with the roof can affect the pH of runoff from the roof. For example, metal and wood shingle roofs tend to acidify the runoff [22, 30], while concrete tiles, asphalt shingles, and similar materials tend to increase the pH [26, 30–32]. Finally, roof pitch may affect accumulation of contaminants on the roof, and therefore contaminants washed off the roof during rainfall events [33].

In recent years, both rainwater harvesting systems and green roofs have been promoted in green buildings. Green roofs can be classified as intensive, involving a thick layer of soil capable of supporting lawns and trees, or extensive, often planted with succulents and/or herbs and requiring little or no maintenance. While green roofs can reduce nitrate and ammonium runoff, they can also become sources of dissolved organic carbon (DOC) [34]. DOC, more specifically assimilable organic carbon, is important in rainwater harvesting systems because it has been linked to potential bacterial regrowth after disinfection in drinking water systems [35]. Green roofs may also act as a source of metals such as lead, iron, and chromium [36]. Similar to other roofing materials, the age of a green roof can impact its pollutant removal capabilities [37, 38]. While soil amendments in green roofs can improve the runoff quality [39, 40], soil amendments can also reduce the quantity of runoff and therefore the quantity of water available for other uses [40]. The reduction in roof runoff volume from green roofs in general can negatively impact the amount of water available for rainwater harvesting for other uses. A modeling study of various combinations of gray water, green roof, and rainwater harvesting systems in Athens, Greece, found that inclusion of a green roof decreased runoff volume by 58 % (compared to just rainwater harvesting and gray water) and increased the need for supplemental water to supply end uses (from 0 to 444.2 m<sup>3</sup>) by decreasing the supply to the rainwater tanks [41]. Chapter “[Sustainable Water Management in](#)

**Green Roofs**” of this book provides details of green roof design and its effects on water management.

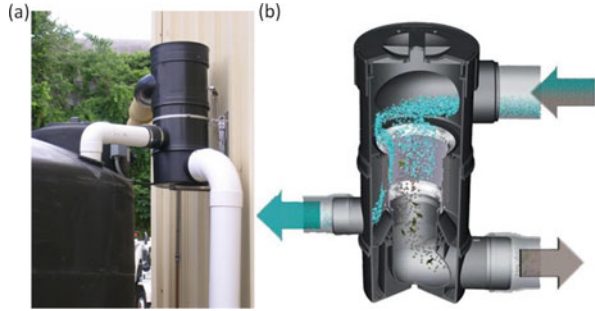
Because of the potential impact of roof materials on the quality of harvested rainwater, the selection of appropriate roof materials is important in the design of a rainwater harvesting system. Avoiding high concentrations of heavy metals, through selection of roof type or additional treatment, is important when harvested rainwater will be used for potable purposes, such as drinking and bathing, but may be less important for non-potable purposes. Membrane roofs, widely used in institutional and large commercial buildings, are generally non-leaching but can still produce contaminated roof runoff due to atmospheric deposition, wildlife fecal matter, and other sources [42]. NSF International (formerly the National Sanitation Foundation) certifies rainwater harvesting systems components, such as roof materials and coatings, under P151 as safe for the collection of drinking water, but these certified roofing materials may still collect contaminants. Depending on the intended harvested rainwater use, different levels of prestorage and post-storage treatment can be recommended.

### ***3.2 Prestorage Treatment***

Contaminant concentration in rooftop runoff water is usually higher at the beginning of a rainfall event because of contaminants from atmospheric deposition and bird droppings. This has led to a common practice of diverting the first few millimeters of rainfall at the start of a rainfall event. These higher initial concentrations, called the “first flush,” have been documented for sediments [21], pesticides [43], bacteria [31, 44], and metals [29]. However, the first flush does not occur in all rainfall events [45]. The presence or absence of the first flush can be affected by roof material [30], duration, interval between rainfall events [46], and type of contaminant. Decreases in concentration of contaminants with time in a rainfall event have led researchers to recommend the use of first flush devices. These are devices installed before the rainwater storage tank that force the first flush to bypass the tank, though no specific design has been supported [33]. In addition, the volume of water that must be bypassed varies for different contaminants [47]. Having a first flush diversion device can significantly reduce the likelihood of unsafe levels of heavy metal contamination in rainwater harvesting systems [48, 49].

Filtering rainwater before storage in the tank is common in most modern rainwater systems, particularly in developed countries. Organic matter is the most common contaminant in surface runoff and can support the growth of bacteria in the rainwater tank. Pre-tank filtration removes this organic matter and can improve the overall quality of harvested rainwater. Pre-tank filtration may also reduce or eliminate debris buildup in the tank, reducing the need for maintenance. In a controlled experiment, O’Hogain et al. [50] found significantly better water quality in rainwater storage tanks when the water was filtered before storage. Similarly, Despins et al. [51] found that pretreatment generally improved water quality across

**Fig. 2** Typical rainwater pre-tank filter installed (a) and cutaway view (b) (Source: Rainwater Management Solutions)



a range of rainwater harvesting systems in Canada. Filters should be easy to clean or self-cleaning, nonclogging, and noncorroding (to avoid introducing contaminants into the tank) [52].

A typical rainwater filter is shown in Fig. 2 – rainwater enters the filter through the highest inlet and is dispersed over a vertical screen. Debris and a small amount of water fall to the bottom and exit to additional stormwater treatment through the lowest outlet, while filtered rainwater is directed to the tank through the middle outlet. While filtering is common practice and logic strongly supports its benefits, little research is available on the impact of pre-tank filtration on the impact of water quality in rainwater harvesting systems.

Introducing water into the tank in a way to minimize sediment disturbance can improve water quality. Settling time in the tank is an important control on water quality and concentrations of many contaminants decrease with storage time. Many of the contaminants in harvested rainwater can settle or become trapped in sediments at the bottom of the tank. Resuspension of these sediments can release contaminants into the water column [53, 54].

### 3.3 Storage Tank

The storage tank is clearly a crucial and often costly part of a rainwater harvesting system. Storage tanks often represent close to 50 % or greater of the cost of a rainwater harvesting system. From an environmental perspective, the rainwater tank can represent a very large portion of the embodied energy of the project and significantly affects life cycle impacts [55]. Very often, rainwater tanks are sized based on rules of thumb or monthly water supply, for example, the approach suggested in the Texas Rainwater Harvesting Manual [17].

Because of the cost and environmental impact of the storage tank, appropriate sizing of the tank is crucial. For a given building roof size and rainfall amount, the amount of water supplied depends on the tank size, with diminishing returns as the tank size increases, except when daily demand exceeds average daily rainfall [56]. Payback periods can be reduced by 35–40 % by appropriately sizing the



storage tank [57]. Payback period initially decreases as tank size increases, then increases with increasing tank size, showing an optimum tank size at the minimum payback period [57].

Simulation of rainwater harvesting systems with a daily time step can accurately characterize both runoff reduction and water supply benefits except in situations of very high demand or small tanks. A reduction in tank size by approximately half from the size required to meet all demand on the rainwater system to an optimal tank size can reduce payback period dramatically while having little impact on water supply (approximately 90 % of demand met) [58]. In a case study of a large office building in the United Kingdom, Ward et al. [59] found that the storage tank was oversized and a 64 % reduction in tank size would have minimal impact on water supply but could decrease the payback period by 45 %. Debate often exists about designing tanks for stormwater management or water supply. Frequently, the discussion involves controlled releases from the tank to “make room” for the next storm event. An optimization approach to modeling and examining environmental and economic benefits from a range of tank sizes can help determine an optimal tank size for these combined goals.

Tank construction materials can affect the quality of harvested rainwater. Cement tanks tend to neutralize acidic rainwater but also leach materials into the stored water. Polyethylene tanks, the most common for most aboveground and small belowground systems, and fiberglass tanks are both available in versions designed for potable water storage. Figure 3 shows above the ground and underground storage tanks of various sizes and materials.

### ***3.4 Post-storage Water Quality and Treatment***

The quality of water supplied from rainwater harvesting systems varies widely and consensus does not exist on the controls on rainwater quality. Typical contaminants of concern include microbial contaminants and heavy metals. While the presence of these contaminants in harvested rainwater can limit the appropriate uses of the water, the ability of rainwater harvesting systems to reduce the quantity of these contaminants in stormwater runoff can provide significant environmental benefits. Identifying typical contaminants and appropriate treatment for these contaminants is important because many users consider rainwater harvesting pollutant free and often do not test even when captured rainwater is used as potable water [48, 60].

#### **3.4.1 Microbial Contaminants**

Microbial contaminants, including bacteria, viruses, and protozoa, are among the most commonly studied contaminants in rainwater harvesting systems, with coliform bacteria the most studied constituent. These contaminants can cause gastrointestinal illness and potentially even sepsis. Coliform concentrations vary widely but are found in the majority of samples from rainwater tanks [33]. The presence of overhanging trees and wildlife fecal matter, from birds, squirrels, etc., greatly



**Fig. 3** Sample rainwater storage tanks for aboveground (a) corrugated metal tank with a membrane liner, (b) 2.1 m<sup>3</sup> polyethylene tank and belowground applications, (c) two 9.5 m<sup>3</sup> polyethylene tanks designed for burial, (d) four 114 m<sup>3</sup> fiberglass storage tanks (Source: Rainwater Management Solutions)

increased the frequency of occurrence of *Campylobacter*, *Giardia* [61], and *Enterococci* [62]. *Pseudomonas* and *E. coli* may be primarily transported by atmospheric circulation and deposited along with rainfall [63]. The extent of microbial contamination in a rainwater harvesting system is affected by the roofing material [30, 44]. In many cases (e.g., the case study by [64]), the quality of harvested rainwater is appropriate for drinking except for microbial quality. In these cases, disinfection, through ultraviolet light, chlorine, ozone, or similar methods, is required to make the water safe for potable uses.

### 3.4.2 Heavy Metals

The concentration of heavy metals in rainwater harvesting systems varies widely, with many studies reporting concentrations well within acceptable levels for drinking water and others reporting concentrations that indicate harvested rainwater is unsafe for human consumption without further treatment. Consumption of heavy metals can cause nervous system damage and impede the functioning of other internal organs, making the avoidance of these metals in potable rainwater harvesting systems crucial. However, Stump et al. [48] found unsafe lead levels in one quarter of sampled rainwater systems (6 % of posttreatment samples). These

metals can also accumulate in the sediment in rainwater tanks, with sediment in sample rainwater tanks meeting the criteria as contaminated soil for lead, zinc, chromium, and copper after approximately 1 year of collection from model roofs [20]. Conversely, many researchers have found that concentrations of heavy metals in rainwater systems are typically below local standards for safe drinking water [64–67]. Temporary changes to ambient air quality, such as nearby fires, can reduce the quality of harvested rainwater [68]. The differences in water quality have not been fully explained and may be due to roof material, sediment, and associated contaminants from roadways [21], atmospheric deposition [26], and other sources. In addition, the differences in quality may be due to system design or duration of water storage.

### 3.4.3 Post-storage Water Treatment Techniques

Additional treatment is often included between the pump and the end use in rainwater harvesting systems, particularly in systems designed for indoor water use. The requirement for post-storage treatment varies depending on the end use (Table 1), but often includes fine sediment filtration and disinfection. Disinfection is most commonly achieved through addition of chlorine or ultraviolet disinfection, but ozone and reverse osmosis are also sometimes used. The effectiveness of these disinfection practices depends on the initial quality of the water and the fine sediment filtration (often  $1\text{ m}^{-6}$  to  $5\text{ m}^{-6}$ ).

**Table 1** Sample guidelines for rainwater harvesting systems by intended use (Adapted from [14])

Use	Suggested treatment options
Potable indoor uses	Pre-filtration – first flush diverter
	Cartridge filtration – 3 $\mu\text{m}$ sediment filter followed by 3 $\mu\text{m}$ activated carbon filter
	Disinfection – chlorine residual of 0.2 ppm or UV disinfection
Non-potable indoor uses	Pre-filtration – first flush diverter
	Cartridge filtration – 5 $\mu\text{m}$ sediment filter
	Disinfection – chlorination with household bleach or UV disinfection
Outdoor uses	Pre-filtration – first flush diverter

Many guidance documents include a similar table identifying treatment requirements

## 4 Rainwater Harvesting Selected Case Studies

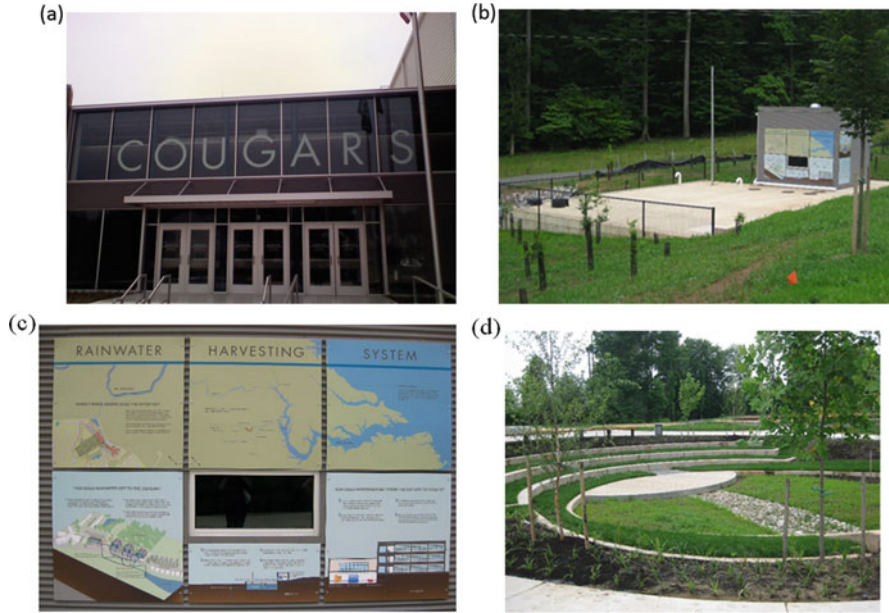
In the modern world, rainwater harvesting for domestic use has been widely practiced in rural and remote localities where centralized water supply systems are nonexistent and/or cost prohibitive [31, 69]. In urban residential areas, rain barrels are often used to capture rooftop rainwater for landscape irrigation and gardening purposes. In recent years, interest in implementing rooftop rainwater harvesting for in-building non-potable water uses, such as flushing toilets, has increased. In the USA, many cities have implemented rainwater harvesting projects in both residential and commercial sectors. Rainwater harvesting is also widely implemented in many other countries including Australia, Brazil, China, India, Germany, and other countries [70]. Recently, the Eiffel Tower in Paris, France, was equipped with rainwater collectors. The collected rainwater will be used to flush the toilets at the tower [71]. A typical example of rainwater harvesting for non-potable uses is illustrated below.

Schools are a natural fit for rainwater harvesting because of the extensive roof area and high demand for toilets and landscape irrigation. In addition, rainwater harvesting systems at schools provide educational benefits and connect students with their water use. An example of a school equipped with a rainwater harvesting system is illustrated below.

Manassas Park Elementary School in suburban Washington D.C., USA, includes a 300 m<sup>3</sup> rainwater storage tank fed by the roof of the building (Fig. 4a). Rainwater passes through a filter then into the poured-in-place concrete tank. The below-ground storage tank is covered by a concrete slab that serves as an outdoor classroom (Fig. 4b), complete with an aboveground pump house including signs describing the rainwater harvesting system (Fig. 4c). In addition, a special water-level gauge, which pushes a color-coded steel pole upwards from the tank by buoyancy, shows students the quantity of water in the tank and increases their awareness of drought and the impacts of their water use.

The rainwater is pumped from the storage tank and through additional water treatment to remove sediments and disinfect the harvested rainwater. The harvested rainwater is then used to supply the toilets and landscape irrigation, with a water well providing backup water supply as needed. In the event of large and/or sustained rainfall events, the excess water overflows into an outdoor amphitheater that also serves as a bioretention area (Fig. 4d). In this way, the rainwater harvesting system is part of a stormwater treatment train. Designers predicted that the system would save 4900 m<sup>3</sup> of potable water per year, but monitoring of the system showed that the potable water savings were actually 30 % higher [72]. While rainwater harvesting was not the only potable water reducing innovation at Manassas Park Elementary School, it has been a major factor in the 85 % reduction in per capita student water use when compared to a neighboring school [72].

Potable use of rainwater is much less common in developed nations but may be emerging as a more common use. For example, greater than 10 % of households use harvested rainwater for potable uses in some cities in Australia [73]. Hammerstrom

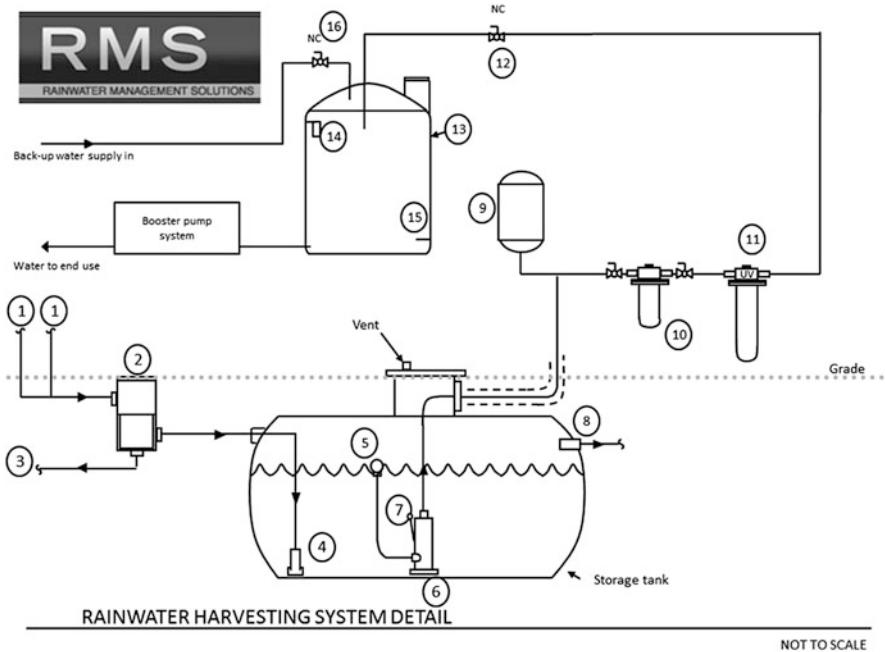


**Fig. 4** The rainwater harvesting system at Manassas Park Elementary School, Virginia (a), includes a pump house that sits on top of the concrete tank which is used as an outdoor classroom (b). The pump house features signs describing the system and the importance of RWH (c). The system overflow is directed to an amphitheater that also functions as a bioretention area (d) (Source: Rainwater Management Solutions)

and Younos [74] investigated rainwater use for household potable purposes in Key Largo, Florida (USA). Two rainwater harvesting examples for potable uses are described below.

The first house built by the ecoMOD project and largely designed by architecture and engineering students at the University of Virginia is designed to use harvested rainwater for potable uses. The goal of the ecoMOD project is combining housing sustainability with affordability [75]. The house is a two-unit structure that also features sustainable harvested wood floors and energy-efficient appliances. It includes an extensive monitoring system that track water and energy use efficiency in the house. The goal of harvesting rainwater helped drive roof design for this project, which includes a single slope roof directing all of the roof runoff to a single location. The rainwater is filtered using a vortex filter before entering the two 6.6 m<sup>3</sup> storage tanks and then receives further treatment (sediment filter, carbon filter, and ultraviolet light) before it is used in the house. Harvested rainwater is the primary source of water for the house, but the system includes automatic backup from the municipal water supply.

The Bullitt Center in Seattle, Washington, USA, home to the Bullitt Foundation, a nonprofit organization, is dedicated to bringing innovative environmental ideas to the Pacific Northwest, USA, and is designed as a net-zero water site [76]. To



- 1 Rainwater collection point (roof drains, gutters, etc)
- 2 Rainwater enters the vortex filter and is processed. Three vortex filters total. (Possible 95% diverted to storage tank.)
- 3 Remaining water from vortex filter to overflow
- 4 Smoothing inlet – stainless steel “flow-calming” device to eliminate turbulence of the incoming water as it enters the tank. One 8” filter is used.
- 5 Floating stainless steel suction filter for uptake of the cleanest water just below the surface
- 6 Submersible feed pump. These pumps are used only to fill the day tank and do not need to be sized to meet peak system demand.
- 7 Low water cut off float switches for pump protection
- 8 Overflow (8”) designed to provide skimming of the water surface and prevent introduction of rodents, etc.
- 9 Pressure tank with tank tee package. The pressure switch activates the pump when pressure drops when 12 opens.
- 10 Filter (either one duplex filter or two single filters). System is designed so that filters can be exchanged without shutting down the system. Filters should have flow capacities to fill the day tank, but do not need to be sized to meet the peak system demand.
- 11 Ultraviolet light for water sterilization. Like the filters and pump, this light does not need to be sized to meet peak demand. Other options, such as ozonation or chlorination, can be used in place of an ultraviolet light. Additional treatment options such as pH injection system can be added here.
- 12 Normally closed solenoid valve opened by 14 when water level in the day tank is low
- 13 Day tank to be located in mechanical room or similar. The day tank should be sized to meet peak demand.
- 14 Level transmitter that controls both 12 and 16. Begins refilling tank with rainwater from the large storage tank at a set level. If rainwater is unavailable and tank level continues to drop, 16 is activated at a lower level to begin filling from municipal water. Transmitter closes both 12 and 16 when the tank is full.
- 15 Level switch (or similar) acts as a fail-safe for 14. If water level drops below this point, the booster pump is disabled and an alarm is activated on the control panel.
- 16 Normally closed solenoid valve activated by 14 to fill the day tank with municipal water.

**Fig. 5** Schematic of a rainwater harvesting system design at the Bullitt Center, Seattle, Washington. This design approach allows for smaller post-tank treatment components which can represent a significant cost savings (*Source*: Rainwater Management Solutions)

become a net-zero water site, a site must not transport water from outside the site or discharge water off the site (infiltration to groundwater is allowed). One of the key features of Bullitt Center design is a potable rainwater harvesting system which includes a 210 m<sup>3</sup> rainwater storage tank and a post-tank treatment system including sediment filtration, carbon filtration, and ultraviolet disinfection (Fig. 5). Rainwater is harvested from the roof, through a pre-tank filter, and then stored in the tank. Water is pumped from the main storage tank through the post-tank treatment (fine filtration and disinfection) to a smaller (1.9 m<sup>3</sup>) day tank. Because the pumping and post-tank treatment equipment can slowly fill the day tank, rather than needing to meet the flow rate demand of the whole building, the post-tank treatment can be downsized from equipment typically need for a building of this size. One of the goals of the Bullitt Center design is mimicking the natural functioning of the site, i.e., absorbing rainfall and releasing water through evapotranspiration; however, legal hurdles impeded the final connection of the rainwater harvesting system creating temporary reliance on the municipal water system [77].

## 5 Rainwater Harvesting Impacts

The increased adoption of rainwater harvesting systems has stemmed from its ability to reduce stormwater runoff as a low-impact development (LID) method, reduce dependency on utility potable water, and potentially reduce energy consumption and water costs. Environmental and economic benefits of rainwater harvesting systems and life cycle analysis are discussed below.

### 5.1 Stormwater Runoff Management

Stormwater management practices originally focused on flood prevention, with systems designed to quickly drain parking lots, roads, and other impervious services. More recently, stormwater management strategies are focused more on reducing the runoff volume from impervious areas, with low-impact development and green infrastructure as prominent features of stormwater management design. Rainwater harvesting is well suited to this approach because it transforms runoff into a valuable resource, is effective at individual sites, and handles runoff at the local level. See chapter “[Urban Stormwater Management: Evolution of Process and Technology](#)” of this volume for detailed description of stormwater management practices.

### 5.1.1 Rainwater Harvesting Impact on Runoff Volume

Rainwater harvesting is emerging as a promising LID best management practice (BMP) for urban stormwater management. Many studies have documented the impact of rainwater harvesting systems on runoff volume reduction (e.g., [78–80]). These studies show rainwater harvesting for stormwater management can be most effective when it is applied in densely populated and multistory buildings where water demand is high relative to captured rainwater.

The effectiveness of rainwater harvesting for stormwater control depends on the magnitude and consistency of the use [81]. Year-round withdrawals of water both logically and experimentally result in superior stormwater management, while systems designed for seasonal irrigation only will overflow during significant portions of the year [82]. In most rainwater harvesting systems, the volume of potable water saved due to captured rainwater use is equal to the volume of rooftop runoff reduced. Rainwater capture and reuse represent a decrease in imports and exports of water from the site. In this sense, rainwater harvesting as an alternative water source and as a BMP is synergistic. Even though non-potable water demands are frequently high, if a large portion of the captured rainwater cannot be used in the built environment, other means of disposal for the excess rooftop runoff can be considered. Possible solutions to address the excess captured rainwater include considering an integrated approach for stormwater management that incorporates other LID-BMPs such as bioretention systems.

Rainwater harvesting is more effective at reducing runoff from small storms than reducing peak flow from very large events. For example, Damodaram et al. [83] showed that rainwater harvesting combined with permeable pavers could more effectively match the hydrograph shape than a traditional detention pond, though the detention pond was more effective at reducing peak flow for design storms. The storage tank used in the modeling (sized for 10 cm of rainfall) is larger than would likely be recommended by a tank optimization approach. In a simulation of rainwater harvesting systems in suburban France, rainwater harvesting systems alone were not effective at reducing peak flows from storms that created storm system overflows unless the tanks were very large, though they may be effective as part of a treatment train [84]. Therefore, in general, rainwater harvesting should not be treated as the only stormwater management practice on a site, but as a valuable component of an integrated stormwater plan. For example, a rainwater harvesting system situated upstream of the bioretention cell can decrease the flow rate to the bioretention area, allowing decreased bioretention cell size and making its implementation feasible where land availability is limited.

Under appropriate conditions, sharing of captured rooftop rainwater between adjacent/nearby buildings can be considered a feasible option. This approach can have potential application in shopping malls where several businesses with varying water demand share the same building and water supply system. In other situations, the excess water can be directed to a recharge well or infiltration trench for storage in the natural aquifer to alleviate groundwater depletion.



### **5.1.2 Rainwater Harvesting Water Quality Impacts**

Rooftop rainwater harvesting impacts from a water quality management perspective should be noted. Some monitoring and modeling studies have shown that rainwater harvesting systems can reduce contaminant concentrations in runoff. For example, DeBusk et al. [85] found that rainwater harvesting systems outperformed typical stormwater control practices in regard to total nitrogen (TN), total phosphorus (TP), and total suspended solids (TSS) reductions. The authors noted that TP concentrations are decreased by mechanical settling, while TN concentrations are likely reduced by biological/chemical processes such as denitrification [85]. Khastagir and Jayasuriva [86] modeled TN, TP, and TSS reductions for a rainwater harvesting system at a single home and showed TN reductions of 44–81 %, TP reductions 70–90 %, and TSS reductions 92–97 %, greatly exceeding the runoff volume reductions of 13–75 %, depending on the intensity of use of harvested rainwater. However, Khastagir and Jayasuriva [86] give no details of how these pollutant reductions were achieved. In a monitoring study in North Carolina (USA), a rainwater harvesting system showed limited impact on nitrogen and phosphorus concentrations but a significant reduction for TSS [87]. Water quality impacts of rainwater harvesting systems on runoff pollutant concentrations remain an area of future research.

### **5.1.3 Potential for Groundwater Preservation**

Many urban areas experience chronic and significant groundwater level decline due to reduced surface infiltration caused by increased impervious areas and excessive groundwater withdrawal for public and industrial consumption. In many coastal cities, the combination of urbanization and excessive groundwater withdrawal has resulted in saltwater intrusion into coastal aquifers.

Integrating rainwater harvesting systems and artificial groundwater recharge systems in urban environments could prevent salt water intrusion into coastal aquifers [88]. In such integrated systems, the excess rooftop runoff (tank overflow after use) can be directed to a recharge well or if land is available to an infiltration trench or similar LID-BMP that can facilitate groundwater recharge. However, implementation of a conjunctive rainwater harvesting groundwater recharge system will require inclusion of appropriate water filtration technologies to prevent groundwater pollution.

## ***5.2 Potable Water Saving and Energy Conservation***

Non-potable uses of potable water constitute a significant portion of water use in the residential, commercial, institutional, and industrial sectors of urban areas.

According to Gleick et al. [89], approximate non-potable uses of potable water are landscaping (35 %), cooling (15 %), laundry (2 %), and toilet flushing (12 %). A holistic approach to water management recognizes that these end uses do not need to be supplied by the water with a drinking water quality standard.

Using a mass balance approach, Liu et al. [90] showed that rainwater harvested from rooftops in an urban area in Beijing could supply 39.84 % of toilet demand for residents. In a rainwater harvesting system monitored for 8 months at an office park in the United Kingdom, harvested rainwater supplied 87 % of the water needed for flushing toilets [60]. Even in arid regions of Australia, harvested rainwater can supply between 61 % and 97 % of water needed for laundry and toilet flushing in a single household [91]. In a case study of separate retail parks in Brazil and Spain, Farrenya et al. [92] found that the volume of rainwater that could be harvested from rooftops and paved surfaces exceeded the total water demand of the site, and even during dry years, rainwater from the rooftops alone could meet 60–90 % of the total demand. The much greater percentage of demand met in the retail parks is likely due to a lower occupant density. Studies assuming that all runoff from the surfaces can be captured, such as Farrenya et al. [92] and Liu et al. [90], serve more as representations of the maximum total potable water use reduction because, in practicality, not all rainwater can be captured – some is lost from splash evaporation and overflow from the system. However, monitoring studies also show significant potential for harvested rainwater to replace other water sources [59, 74, 91].

A major benefit of rainwater harvesting systems is reducing the use of energy intensive municipal potable water supply. Supplying municipal water and treating stormwater are energy intensive processes. Water is pumped long distances and virtually all water is treated to a potable level (the exception is municipal reclaimed water systems). In a study on the Loess Plateau in China, energy use for rainwater harvesting was only 42 % of energy use for water supplied from the public water system [93]. The rainwater harvesting system installed at Star City in South Korea uses 90 % less energy than the municipal system [94]. The reader is referred to chapter “[Carbon Footprint of Water Consumption in Urban Environments: Mitigation Strategies](#)” of this book for a detailed discussion on the impact of rooftop rainwater harvesting on potable water and energy savings and carbon footprint reduction of potable water consumption.

### **5.3 Economic Benefits**

Many people pursue rainwater harvesting because of perceived economic savings, but research shows that not all rainwater harvesting systems lead to financial gain. In a study across a range of tank sizes and uses, numerical analysis showed that municipal water supply was less expensive through the life of the system for over 3000 rainwater harvesting system configurations, largely due to the cost of replacement parts [95]. Payback analysis is highly sensitive to utility costs [96]. Across a range of land uses and regions in Virginia (USA), no optimized rainwater

harvesting systems showed a positive payback after 50 years, but this included static utility rates and did not include a reduction in other stormwater infrastructure [96]. The financial benefit of a rainwater harvesting system for flood control can be a more important economic benefit than the savings from potable water [97]. Additionally, larger rainwater harvesting systems may be more financially profitable due to economies of scale. These economies of scale extend to neighborhood-level (vs. single-residence level) rainwater harvesting systems [98, 99], with an optimum number of houses included in the system determined by a balance of the cost of storage and treatment for individual systems and an extensive piping system for neighborhood systems [100]. In addition, the cost of public water supply significantly affects the economic feasibility of rainwater harvesting, but more surprisingly, water hardness, which increases detergent use and decreases lifespan of appliances and is typically low in harvested rainwater, can also affect the economic benefit or loss from rainwater harvesting [100].

Government subsidies and tax breaks are often used to encourage rainwater harvesting. Rahman et al. [101] found that government subsidies, greater than those currently offered by the Australian government, were required for the financial benefits of a rainwater harvesting system to outweigh the costs over a 40-year expected life. Subsidies can also help in developing countries where rainwater harvesting systems may be beyond the financial options of citizens. In a study of options for water supply in arsenic-affected areas of Cambodia, rainwater harvesting was one of the least expensive options, though still too expensive for the poorest 20 % of the population without subsidies [102].

The lack of consistent financial benefit from rainwater harvesting systems may be created more by the design of the systems and the research approach than by an actual lack of financial benefit from rainwater harvesting. As discussed earlier, the size of the rainwater storage tank has a significant impact on the financial payback and is often not optimized in these studies. In addition, static utility rates are often used, while water and electricity costs are increasing. Newly emerging contaminants of concern and required treatment combined with necessary repairs to aging infrastructure and a need to investigate novel water sources will all likely lead to large increases in the cost of potable water in coming years. Finally, many studies examine the financial benefits of rainwater harvesting systems as water supply options only and do not consider benefits from a stormwater management perspective (such as decrease in the size of a bioretention cell) which help offset the upfront costs of a rainwater harvesting system. Better analysis of the financial costs and benefits of rainwater harvesting systems is needed in the future.

## ***5.4 Life Cycle Assessment***

The environmental and economic benefits of rainwater harvesting seem obvious. However, a true evaluation of these benefits requires life cycle analysis, which shows that these benefits are dependent upon system design. Some of the most

important factors in determining the lifetime impact of a rainwater harvesting system are the pumping energy use, embodied energy of the tank, and construction energy use.

Devkota et al. [103] examined five construction scenarios including rainwater harvesting systems at a dormitory building in Ohio (USA) and found that almost all scenarios produced a net reduction in greenhouse gas emissions and energy use, particularly if discharging to a combined sewer system. The five scenarios studied included business as usual, harvested rainwater for irrigation in a renovated building, harvested rainwater for toilet flushing in a renovated building, harvested rainwater for toilet flushing in a renovated building, and harvested rainwater for toilet flushing in a new building with lower occupancy. Using EEAST, a life cycle model developed to examine rainwater harvesting systems, CO<sub>2</sub>, and energy payback periods was 10–12 years for rainwater harvesting, but cost payback periods were as long as 64 years (Devkota et al.) [104]. These payback periods are likely overestimates because the storage tank used in their sample building was sized to store a full month's roof runoff.

Scientific literature on tank sizing indicates that storage tanks in temperate regions are much more efficient when sized for typical rainfall events, not an entire month of rain. Both the environmental and economic paybacks of rainwater harvesting systems are sensitive to the size of the storage tank [100]. In a study of a rainwater harvesting system on an office building in the United Kingdom, the oversized tank, as installed, resulted in an 11-year economic payback of the system, while an appropriately sized tank, a smaller tank which provides the same quantity of water, would have a 6-year economic payback [59]. In an analysis of hypothetical rainwater harvesting systems in 14 US cities, only the system in Seattle, with frequent rainfall and a high stormwater fee, showed a new economic gain over the life cycle of the system [105]. While this study considered the benefits from a stormwater perspective, it used static utility fees, which likely impact the payback period. Other studies have found that rainwater harvesting is only financially viable if current water prices increase [106].

The environmental and economic benefits of rainwater harvesting both depend on the “business as usual” scenario. When comparing toilet flushing options for developing countries, the use of harvested rainwater in high-efficiency toilets has significant environmental and cost benefits, while using harvested rainwater in standard toilets represents no benefits compared potable water in standard toilets [107]. When considered against other water supply options such as desalination, and even groundwater abstraction, rainwater and stormwater harvesting had the lowest environmental impact for future water supply in a community near Copenhagen, with reduced electricity use in households due to lower water hardness accounting for a large portion of the benefit [108].

## 6 Conclusions

Rainwater harvesting systems offer a powerful solution to water supply and stormwater management challenges. However, the quality of the water supplied and the economic and environmental benefits of the systems are highly dependent on system design. While studies have shown contamination of stored rainwater supplies with heavy metals and microbes, when systems with appropriate filtration and treatment are studied, water quality is consistently appropriate for the designated use.

Further research is needed on the impact of system design on the quality of stored rainwater. This type of research is particularly important for rainwater systems used for non-potable uses such as toilet flushing. An abundance of concern has led many regulators, particularly in the United States, to require disinfection of harvested rainwater for these uses, though research has shown that infection risk from microbial contamination of harvested rainwater used for toilet flushing is minimal [109]. Improved characterization of the risk of using harvested rainwater and system design characteristics, particularly those involving roof surfaces and prestorage treatment that result in negligible risk, could result in a relaxing of requirements for disinfection for non-potable use. Removal of post-tank treatment could reduce the life cycle impacts, financial cost, and energy use of rainwater harvesting systems.

Improved research on life cycle assessments is also needed. When tank sizes are optimized for the supply and demand of the system, rainwater harvesting systems show significant financial and environmental benefits, but many life cycle assessment studies do not include this optimization step. Further controlled experiments on the impacts of systems design and tighter parameterization of components in life cycle analysis are needed to optimize rainwater harvesting systems and realize their full benefits. Finally, rainwater harvesting systems for urban water management are becoming more critical, particularly in the context of a changing climate.

## References

1. Mays LW (2014) Use of cisterns during antiquity in the Mediterranean region for water resources sustainability. *Water Sci Technol* 14(1):38–47
2. Mays L, Antoniou GP, Angelakis AN (2013) Review: history of water cisterns. *Water* 5: 1916–1940
3. Crouch DP (1993) *Water management in ancient Greek cities*. Oxford University Press, New York, p 400
4. Vetter T, Riegera AK, Nicolaya A (2009) Ancient rainwater harvesting systems in the north-eastern Marmarica (north-western Egypt). *Libyan Stud* 40:9–23. doi:[10.1017/S0263718900004489](https://doi.org/10.1017/S0263718900004489)
5. Guttman-Bond E (2010) Sustainability out of the past: how archaeology can save the planet. *World Archaeol* 42(3):355–366. doi:[10.1080/00438243.2010.497377](https://doi.org/10.1080/00438243.2010.497377)

6. Ferrand EA, Cecunjanin F (2014) Potential of rainwater harvesting in a thirsty world: a survey of ancient and traditional rainwater harvesting applications. *Geogr Compass* 8(6): 395–413
7. WHO and UNICEF (2015) Progress on sanitation and drinking water – 2015 update and Millennium Development Goals (MDG) assessment. United Nations, New York. Available: [http://www.wssinfo.org/fileadmin/user\\_upload/resources/JMP-Update-report-2015\\_English.pdf](http://www.wssinfo.org/fileadmin/user_upload/resources/JMP-Update-report-2015_English.pdf). Accessed 30 Sept 2015
8. Hejazi MI, Edmonds J, Clarke L, Kyle P, Davies E, Chaturvedi V, Calvin K (2014) Integrated assessment of global water scarcity over the 21st century under multiple climate change mitigation policies. *Hydrol Earth Syst Sci* 18(8):2859–2883
9. Döll P, Müller S, Schuh C, Portmann FT, Eicker A (2014) Global-scale assessment of groundwater depletion and related groundwater abstractions: combining hydrological modeling with information from well observations and GRACE satellites. *Water Resour Res* 50(7):5698–5720
10. Jacobson MZ, Ten Hoeve JE (2012) Effect of urban surfaces and white roofs on global and regional climate. *J Climate* 25(3):1028–1044
11. New York City Environmental Protection (2014) Water demand management plan. Available: <http://www.nyc.gov/html/dep/pdf/conservation/water-demand-management-plan-spread.pdf>. Accessed 19 Nov 2015
12. National Oceanic and Atmospheric Administration (NOAA) (2015) National centers for environmental information, state of the climate: global analysis for annual 2014, published online January 2015. <http://www.ncdc.noaa.gov/sotc/global/201413>. Accessed 19 Nov 2015
13. Younos T (2011) Paradigm shift: holistic approach for water management in urban environments. *Front Earth Sci* 5(4):421–427
14. Kloss C (2008) Managing wet weather with green infrastructure. Municipal Handbook Rainwater Harvesting Policies, EPA Low Impact Development Center. [http://water.epa.gov/infrastructure/greeninfrastructure/upload/gi\\_municipalhandbook\\_harvesting.pdf](http://water.epa.gov/infrastructure/greeninfrastructure/upload/gi_municipalhandbook_harvesting.pdf). Accessed 6 Nov 2015
15. United Nations Environment Programme (UNEP) (2009) Rainwater – a handbook on rainwater harvesting in the Caribbean. <http://www.unep.org/ecosystemmanagement/Portals/7/Documents/em-rainwater-handbook-caribbean.pdf>. Accessed 6 Nov 2015
16. Lawson S, LaBranche-Tucker A, Otto-Wack H, Hall R, Sojka B, Crawford E, Crawford D, Brand C (2009) Virginia rainwater harvesting manual, 2nd ed. The Cabell Brand Center for Global Poverty and Resources Sustainability Studies, Salem. [www.cabellbrandcenter.org](http://www.cabellbrandcenter.org). Accessed 1 Nov 2015
17. Texas Rainwater Harvesting Manual (2005) Texas water control board. <http://www.twdb.texas.gov/innovativewater/rainwater/docs.asp>. Accessed 1 Nov 2015
18. ARCSA/ASPE/ANSI (2013) Rainwater catchment systems, plumbing engineering & design standard – 63-2013. ARCSA (American Rainwater Catchment Systems Association), American Society of Plumbing Engineers (ASPE) and American National Standards Institute (ANSI), Rosemont, IL
19. ARCSA/ASPE/ANSI (2015) Stormwater harvesting system design for direct end-use applications – 78-2015. ARCSA (American Rainwater Catchment Systems Association), American Society of Plumbing Engineers (ASPE) and American National Standards Institute (ANSI), Rosemont, IL
20. Magyar MI, Ladson AR, Diaper C, Mitchell VG (2014) Influence of roofing materials and lead flashing on tank contamination by metals. *Aust J Water Resour* 18(1):71–83
21. van Metre PC, Mahler BJ (2003) The contribution of particles washed from rooftops to contaminant loading to urban streams. *Chemosphere* 52:1727–1741
22. Chang MM, McBroom MW, Scott BR (2004) Roofing as a source of nonpoint water pollution. *J Environ Manage* 73(4):307–315

23. Jungnickel CF, Stock TB, Ranke J (2008) Risk assessment of biocides in roof paint. Part 1: experimental determination and modelling of biocide leaching from roof paint. *Environ Sci Pollut Res Int* 15(3):258–265
24. Moilleron R, Gonzalez A, Chebb G, Thévenot DR (2002) Determination of aliphatic hydrocarbons in urban runoff samples from the “Le Marais” experimental catchment in Paris centre. *Water Res* 36:1275–1285. doi:[10.1016/S0043-1354\(01\)00322-0](https://doi.org/10.1016/S0043-1354(01)00322-0)
25. Polkowska Z, Górecki T, Namieśnik J (2002) Quality of roof runoff waters from an urban region (Gdańsk, Poland). *Chemosphere* 491:275–1283
26. Förster J (1999) Variability of roof runoff quality. *Water Sci Technol* 39(5):137–144
27. Clarke SE, Steele KA, Spicher J, Siu CYS, Lalor MM, Pitt R, Kirby JT (2008) Roofing materials’ contributions to storm-water runoff pollution. *J Irrig Drain Eng-ASCE* 134(5): 638–645
28. Adeniyi IF, Olanbaji IO (2005) The physico-chemical and bacteriological quality of rainwater collected over different roofing materials in Ile-Ife, southwestern Nigeria. *Chem Ecol* 21(3):149–166
29. Zobrist J, Muller SR, Ammann A, Bucheli TD, Mottier VM, Ochs R, Schoenenberger JE, Boller M (2000) Quality of roof runoff for groundwater infiltration. *Water Res* 34:1455–1462
30. Mendez CB, Klenzendorf JB, Afshar BR, Simmons MT, Barrett ME, Kinney KA, Kirisits MJ (2011) The effect of roofing material on the quality of harvested rainwater. *Water Res* 45(5):2049–2059
31. Yaziz MI, Gunting H, Sapari N, Ghazali AW (1989) Variations in rainwater quality from roof catchments. *Water Res* 23(6):761–765
32. Chang M, Crowley CM (1993) Preliminary observations on water quality of storm runoff from four selected residential roofs. *J Am Water Resour Assoc* 29(5):777–783
33. Gikas GD, Tsihrintzis VA (2012) Assessment of water quality of first-flush roof runoff and harvested rainwater. *J Hydrol* 466:115–126. doi:[10.1016/j.jhydrol.2012.08.020](https://doi.org/10.1016/j.jhydrol.2012.08.020)
34. Berndtsson JC, Bengtsson L, Jinno K (2009) Runoff water quality from intensive and extensive vegetated roofs. *Ecol Eng* 35:369–380
35. van der Kooij D (1992) Assimilable organic carbon as an indicator of bacterial regrowth. *J Am Water Works Assoc* 84(2):57–65
36. Berndtsson JC, Emilsson T, Bengtsson L (2006) The influence of extensive vegetated roofs on runoff water quality. *Sci Total Environ* 355:48–63
37. Harper GE, Limmer MA, Showalter WE, Burken JG (2015) Nine-month evaluation of runoff quality and quantity from an experiential green roof in Missouri. *Ecol Eng* 78:127–133
38. Gong K, Wu Q, Peng S, Zhao X, Wang X (2014) Research on the characteristics of the water quality of rainwater runoff from green roofs. *Water Sci Technol* 70(7):1205–1210
39. Vijayaraghavan K, Raja FD (2015) Pilot-scale evaluation of green roofs with Sargassum biomass as an additive to improve runoff quality. *Ecol Eng* 75:70–78
40. Beck DA, Johnson GR, Spolek CA (2011) Amending greenroof soil with biochar to affect runoff water quantity and quality. Selected papers from the conference Urban Environmental Pollution: Overcoming Obstacles to Sustainability and Quality of Life (UEP2010), 20–23 June 2010, Boston. *Environ Pollut* 159(8):2111–2118
41. Stratigea D, Makropoulos C (2015) Balancing water demand reduction and rainfall runoff minimisation: modelling green roofs, rainwater harvesting and greywater reuse systems. *Water Sci Technol* 15(2):248–255
42. Cupido A, Baetz B, Yiping G, Robertson A (2012) An evaluation of rainwater runoff quality from selected white roof membranes. *Water Qual Res J Can* 47(1):66–79
43. Bucheli TD, Müller SR, Heberle S, Schwarzenbach RB (1998) Occurrence and behavior of pesticides in rainwater, roof runoff, and artificial stormwater infiltration. *Environ Sci Technol* 32(22):3457–3464
44. Lee JY, Bak G, Han M (2012) Quality of roof-harvested rainwater—comparison of different roofing materials. *Environ Pollut* 162:422–429

45. Athanasiadis K, Horn H, Helmreich B (2010) A field study on the first flush effect of copper roof runoff. *Corros Sci* 52:21–29
46. He W, Odnevall Wallinder I, Leygraf C (2001) A laboratory study of copper and zinc runoff during first flush and steady-state conditions. *Corros Sci* 43:127–146
47. Kus B, Kandasamy J, Vigneswaran S, Shon HK (2010) Analysis of first flush to improve the water quality in rainwater tanks. *Water Sci Technol* 61(2):421–428
48. Stump B, McBroom M, Darville R (2012) Demographics, practices and water quality from domestic potable rainwater harvesting systems. *J Water Supply Res Technol-AQUA* 61(5): 261–271
49. Huston R, Chan YC, Chapman H, Gardner T, Shaw G (2012) Source apportionment of heavy metals and ionic contaminants in rainwater tanks in a subtropical urban area in Australia. *Water Res* 46(4):1121–1132
50. O'Hogain S, McCarton L, McIntyre N, Pender J, Reid A (2012) Physicochemical and microbiological quality of harvested rainwater from an agricultural installation in Ireland. *Water Environ J* 26(1):1–6
51. Despins C, Farahbakhsh K, Leidl C (2009) Assessment of rainwater quality from rainwater harvesting systems in Ontario, Canada. *Aqua* 58(2):117–134
52. Abbasi T, Abbasi SA (2011) Sources of pollution in rooftop rainwater harvesting systems and their control: critical review. *Environ Sci Technol* 41(23):2097–2167
53. Magyar MI, Ladson AR, Mitchell VG, Diaper C (2011) The effect of rainwater tank design on sediment re-suspension and subsequent outlet water quality. *Aust J Water Resour* 15(1): 71–84
54. Magyar MI, Ladson AR, Diaper C (2011) Sediment transport in rainwater tanks and implications for water quality. In: Manning AJ (ed) *Sediment transport in aquatic environments*. InTech-Open Access Publisher, p 344. <http://www.intechopen.com/books/sediment-transport-in-aquatic-environments>
55. Ghimire SR, Johnston JM, Ingwersen WW, Hawkins TR (2014) Life cycle assessment of domestic and agricultural rainwater harvesting systems. *Environ Sci Technol* 48 (7):4069–4077
56. Campisano A, Modica C (2015) Appropriate resolution timescale to evaluate water saving and retention potential of rainwater harvesting for toilet flushing in single houses. *J Hydroinform* 17(3):331–346
57. Silva CM, Sousa V, Carvalho NV (2015) Evaluation of rainwater harvesting in Portugal: application to single-family residences. *Resour Conserv Recycl* 94:21–34. doi:10.1016/j.resconrec.2014.11.004
58. Sanches Fernandes LF, Terêncio DPS, Pacheco FAL (2015) Rainwater harvesting systems for low demanding applications. *Sci Total Environ* 529:91–100
59. Ward S, Memon FA, Butler D (2012) Performance of a large building rainwater harvesting system. *Water Res* 46(16):5127–5134
60. Marks JS, Martin B, Zadoroznyj M (2008) How Australians order acceptance of recycled water: national baseline data. *J Sociol* 44(1):83–99
61. Ahmed W, Gardner T, Toze S (2011) Microbiological quality of roof-harvested rainwater and health risks: a review. *J Environ Qual* 40(1):13–21
62. Ahmed W, Hodggers L, Sidhu JPS, Toze S (2012) Fecal indicators and zoonotic pathogens in household drinking water taps fed from rainwater tanks in Southeast Queensland, Australia. *Appl Environ Microbiol* 78(1):219–226
63. Kaushik R, Balasubramanian R (2012) Assessment of bacterial pathogens in fresh rainwater and airborne particulate matter using real-time PCR. *Atmos Environ* 46:131–139
64. Abdulla FA, Al-Shareef A (2009) Roof rainwater harvesting systems for household water supply in Jordan. *Desalination* 243:95–207. doi:10.1016/j.desal.2008.05.013
65. Domènech L, Saurí D (2011) A comparative appraisal of the use of rainwater harvesting in single and multi-family buildings of the metropolitan area of Barcelona (Spain): social experience, drinking water savings and economic costs. *J Clean Prod* 19(6):598–608



66. Morrow A, Dunstan R, Coombes P (2010) Elemental composition at different points of the rainwater harvesting system. *Sci Total Environ* 408(20):4542–4548
67. Sazakli E, Alexopoulos A, Leotsinidis M (2007) Rainwater harvesting, quality assessment and utilization in Kefalonia Island, Greece. *Water Res* 41(9):2039–2047
68. Spinks J, Phillips S, Robinson P, Van Buynder P (2006) Bushfires and tank rainwater quality: a cause for concern? *J Water Health* 4(1):21–28
69. Younos T, Bohdan R, Anderson E, Ramsey K, Cook N, Ross BB, Dillaha T (1998) Evaluation of rooftop rainfall collection-cistern storage systems in southwest Virginia. VWRRC SP3–1998, Virginia Tech, Blacksburg
70. Center for Science and Environment (CSE) (2011) Rainwater harvesting in urban areas. <http://www.rainwaterharvesting.org/Urban/Urban.htm>. Accessed 1 Nov 2015
71. UPI (2015) Eiffel Tower fitted with wind turbines, solar panels, rainwater collectors. UPI News, 25 Feb 2015. [http://www.upi.com/Top\\_News/World-News/2015/02/25/Eiffel-Tower-fitted-with-wind-turbines-solar-panels-rainwater-collectors/7471424873684/ph3/](http://www.upi.com/Top_News/World-News/2015/02/25/Eiffel-Tower-fitted-with-wind-turbines-solar-panels-rainwater-collectors/7471424873684/ph3/). Accessed 1 Nov 2015
72. Miazga M (2012) Creatively green. *PM Eng* 18(4):16–18
73. Australian Bureau of Statistics (ABS) (2007) Environmental issues: people's views and practices. <http://www.abs.gov.au/ausstats/abs@.nsf/mf/4602.0>. Accessed 16 Nov 2015
74. Hammerstrom J, Younos T (2014) Single-family home rainwater-harvesting system demonstration project for stormwater-runoff control and utility-water saving. The Cabell Brand Center special report no. 100-2014. [www.cabellbrandcenter.org](http://www.cabellbrandcenter.org)
75. Quale JD (2012) Sustainable, affordable, pre-fab: the ecoMOD project. University of Virginia Press, Charlottesville
76. Morton J (2013) A path to net-zero water. *Buildings* 107(8):28
77. Capps K (2014) Bullitt center exceeds energy goals. *Archit Rec* 202(6):32
78. Herrmann T, Hasse K (1997) Ways to get water: rainwater utilization or long distance water supply. *Water Sci Technol* 36(8–9):313–318
79. Gowland D, Younos T (2008) Feasibility of rainwater harvesting BMP for stormwater management. VWRRC SR38–2008, Virginia Tech, Blacksburg
80. van der Sterren M, Rahman A, Dennis GR (2012) Implications to stormwater management as a result of lot scale rainwater tank systems: a case study in Western Sydney, Australia. *Water Sci Technol* 65(8):1475–1482
81. Steffen J, Jensen M, Pomeroy CA, Burian SJ (2013) Water supply and stormwater management benefits of residential rainwater harvesting in U.S. cities. *J Am Water Resour Assoc* 49(4):810–824
82. DeBusk KM, Hunt WF, Wright JD (2013) Characterizing rainwater harvesting performance and demonstrating stormwater management benefits in the humid southeast USA. *J Am Water Resour Assoc* 49(6):1398–1411
83. Damodaram C, Giacomoni MH, Khedun P, Holmes C, Ryan A, Saour W, Zechman EM (2010) Simulation of combined best management practices and low impact development for sustainable stormwater management. *J Am Water Resour Assoc* 46(5):907–918
84. Petrucci G, Deroubaix JF, de Gouvello B, Deutsch JC, Bompard P, Tassina B (2012) Case study: rainwater harvesting to control stormwater runoff in suburban areas. *Urban Water J* 9(1):45–55
85. DeBusk KM, Hunt WF (2014) Impact of rainwater harvesting systems on nutrient and sediment concentrations in roof runoff. *Water Sci Technol* 14(2):220–229
86. Khastagir A, Jayasuriya LNN (2010) Impacts of using rainwater tanks on stormwater harvesting and runoff quality. *Water Sci Technol* 62(2):324–329
87. Wilson CE, Hunt WF, Winston RJ, Smith P (2014) Assessment of a rainwater harvesting system for pollutant mitigation at a commercial location in Raleigh, NC, USA. *Water Sci Technol* 14(2):283–290
88. Grady C, Younos T (2010) Water use and sustainability in La Altagracia, Dominican Republic. VWRRC SR49–2010, Virginia Tech, Blacksburg

89. Gleick PH, Haasz D, Henges-Jack C, Srinivasan V, Wolff G, Cushing KK, Mann A (2003) Waste not, want not: the potential for urban water conservation in California. Pacific Institute for Studies in Development, Environment, and Security, Oakland
90. Liu W, Chen W, Peng C, Wu L, Qian Y (2015) A water balance approach to assess rainwater availability potential in urban areas: the case of Beijing, China. *Water Sci Technol* 15(3): 490–498
91. Evan H, Rahman A (2014) Rainwater utilization from roof catchments in arid regions: a case study for Australia. *J Arid Environ* 111:35–41
92. Farrenya R, Rieradevall J, Barbassad AP, Teixeira B, Gabarell X (2013) Case study: indicators for commercial urban water management: the cases of retail parks in Spain and Brazil. *Urban Water J* 10(4):281–290
93. Jiang Z, Li X, Ma Y (2013) Water and energy conservation of rainwater harvesting system in the Loess Plateau of China. *J Integr Agric* 12(8):1389–1395
94. Han MY, Mun JS (2011) Operational data of the Star City rainwater harvesting system and its role as a climate change adaptation and a social influence. *Water Sci Technol* 63(12): 2796–2801
95. Roebuck RM, Oltean-Dumbrava C, Tait S (2011) Whole life cost performance of domestic rainwater harvesting systems in the United Kingdom. *Water Environ J* 25:355–365
96. Sample DJ, Liu J (2014) Optimizing rainwater harvesting systems for the dual purposes of water supply and runoff capture. *J Clean Prod* 75:174–194
97. Zhang X, Hu M (2014) Effectiveness of rainwater harvesting in runoff volume reduction in a planned industrial park, China. *Water Resour Manag* 28:671–682
98. Gurung TR, Sharma A (2014) Communal rainwater tank systems design and economies of scale. *J Clean Prod* 67:26–36
99. Morales-Pinzon T, Rieradevall J, Gasol CM, Gabarell X (2015) Modelling for economic cost and environmental analysis of rainwater harvesting systems. *J Clean Prod* 87:613–626
100. Morales-Pinzon T, Lurena R, Gabarell X, Gasol CM, Rieradevall J (2014) Financial and environmental modelling of water hardness – implications for utilising harvested rainwater in washing machines. *Sci Total Environ* 470–471:1257–1271
101. Rahman A, Keane J, Imteaz MA (2012) Rainwater harvesting in Greater Sydney: water savings, reliability and economic benefits. *Resour Conserv Recycl* 61:16–21
102. Chamberlain JF, Sabatini DA (2014) Water-supply options in arsenic-affected regions in Cambodia: targeting the bottom income quintiles. *Sci Total Environ* 488–489:521–531
103. Devkota J, Schlachter H, Apul D (2015) Life cycle based evaluation of harvested rainwater use in toilets and for irrigation. *J Clean Prod* 95:311–321
104. Devkota J, Schlachter H, Anand C, Phillips R, Apul D (2013) Development and application of EEAST: a life cycle based model for use of harvested rainwater and composting toilets in buildings. *J Environ Manag* 130:397–404
105. Wang R, Zimmerman JB (2015) Economic and environmental assessment of office building rainwater harvesting systems in various U.S. cities. *Environ Sci Technol* 49(3):1768–1778
106. Farrenya R, Gabarell X, Rieradevall J (2011) Cost-efficiency of rainwater harvesting strategies in dense Mediterranean neighborhoods. *Resour Conserv Recycl* 55:686–694
107. Anand C, Apul DS (2011) Economic and environmental analysis of standard, high efficiency, rainwater flushed, and composting toilets. *J Environ Manag* 92(3):419–428
108. Godskesen B, Hauschild M, Rygaard M, Zambrano K, Albrechtsen H-J (2013) Life-cycle and freshwater withdrawal impact assessment of water supply technologies. *Water Res* 47(7): 2363–2374
109. Fewtrell L, Kay D (2007) Quantitative microbial risk assessment with respect to *Campylobacter* spp. in toilets flushed with harvested rainwater. *Water Environ J* 21(4):275–280

# Irrigating Urban Agriculture with Harvested Rainwater: Case Study in Roanoke, Virginia, USA

Tammy E. Parece, Malayshia Lumpkin, and James B. Campbell

## Contents

1	Introduction .....	236
2	Urban Agriculture Is an Urban Greenspace .....	237
2.1	Urban Sustainability and Greenspaces .....	237
2.2	Urban Agriculture .....	238
2.3	Urban Agriculture's Water Needs .....	239
3	Case Study .....	244
3.1	Study Site .....	244
3.2	Methods .....	248
3.3	Results .....	253
4	Conclusions and Recommendations for Additional Research .....	258
	References .....	259

**Abstract** Considered at the global scale, urbanization forms the principal source of landscape change. Worldwide, urban areas are increasing in size, both in land area and in population, causing losses of vegetated lands, increases in impervious surface cover, and increased demands on existing infrastructure and upon municipal services such as water and waste management. Urbanization, by reducing vegetative cover and increasing impervious surfaces, alters hydrologic cycles by reducing infiltration, increasing runoff volume and rates, lowering groundwater tables, decreasing evapotranspiration, and creating precipitation anomalies. Urban greenspaces are recognized as providing environmental benefits, including reduced stormwater runoff, increased evapotranspiration, and increased subsurface infiltration, which, in turn, raise groundwater tables. Urban agriculture forms a greenspace that can provide these environmental benefits, among others, in addition to contributing to food security for local populations. This chapter provides an overview of urban agriculture and its potential benefits. Then, we provide a case study based upon the City of Roanoke, Virginia, USA. We identify areas of existing urban

---

T.E. Parece (✉) • M. Lumpkin • J.B. Campbell  
Department of Geography, Virginia Polytechnic Institute and State University, Blacksburg,  
VA, USA  
e-mail: [tammyep@vt.edu](mailto:tammyep@vt.edu)

agriculture using aerial imagery. We discuss land available for potential new urban agricultural sites. From aerial images and city geospatial data, we identify and calculate roof areas that can be used to capture rainwater. Then using precipitation data and equations identified from the literature, we calculated amounts of rainwater that could be harvested to provide irrigation water for these locations. Finally, we discuss reductions that could occur in stormwater runoff and greenhouse gas emissions if harvested rainwater were used instead of municipal water supplies. Additionally, we discuss future research areas for urban agriculture and rainwater harvesting.

**Keywords** Community gardens • Greenhouse gas emissions • Rainwater harvesting • Roanoke, Virginia, USA • Urban agriculture

## 1 Introduction

Humans have modified over 50 % of the Earth's land surface [1]. Modifications began thousands of years ago when humans first transitioned from hunters and gatherers to developing the land for agriculture [2]. The first urban areas developed in regions of the world amenable to food production (i.e., fertile soils adjacent to water), e.g., Mesopotamia (4000 BCE–3000 BCE) and the Indus Valley (2500 BCE–1500 BCE) [2, 3]. Innovations in the ability to produce and store excess food formed the capacity to sustain growing populations [2].

Worldwide human population first reached one billion in 1804 and then grew exponentially because of enhanced human welfare due to Industrial Revolution, the ability to provide potable water and sanitation services, and innovations in healthcare. Exponential growth is expected to continue with worldwide population to reach 9.6 billion by 2050 [4].

The year 2009 was a significant milestone. Prior to 2009, worldwide, the majority of people lived in rural areas; after 2009, the majority lived in urban areas. The United Nations estimates that the percentage of people living in urban areas will rise to 66 % by 2050 [5]. Furthermore, the World Bank [6] predicts that, by 2050, the number of people living in urban areas will actually exceed world population totals in 2000. The proportion of people living in urban versus rural areas varies across the world – an average of 75 % for developed countries and 45 % for less developed countries. These trends are also predicted to increase – North America, Latin America, and Europe to >80 %, Asia to 64 %, and Africa to 54 % – all by 2050.

Landscape change due to accelerated urbanization is the most significant land modification occurring in the world today [7, 8]. Although urban areas are increasing in size with respect to both land area and human population [7–9], rates of conversion to urban land uses greatly exceed rates of urban population increases

[9]. In developing countries, urban land area increases are largely related to increasing populations. In many areas of the developed world, some urban areas are expanding because of population growth and expansion as people move from urban centers to urban fringes, and coupled with this expansion comes land abandonment of inner cities [10].

Ultimately, effects of urbanization, demographic and environmental across the world, have similar impacts. These effects include losses of vegetated lands, expansion of impervious surface cover, disruption of the hydrologic cycle (reduction in evapotranspiration and ground infiltration and increased stormwater runoff and flashiness of rivers and streams), increasing demands on existing infrastructures, higher air temperatures as compared to adjacent rural areas, and increasing demands on municipal services such as potable water and waste management [8]. Urban areas must import food, energy, and clean water to meet basic needs of their populations, and, as such, adverse effects of urbanization extend well beyond political boundaries [7, 8, 11–13]. In order to prevent these problems from expanding and to mitigate current effects, officials are evaluating and implementing efforts to make urban areas more sustainable. Urban agriculture forms a significant greening effort gaining wide attention because of its ability to mitigate these effects as it simultaneously provides nutritional food for populations [6, 14–17].

In this chapter, we introduce urban agriculture as a functional greenspace and review its potential to assist in efforts to improve urban sustainability. Most specifically, we focus on its potential to reinvigorate the hydrologic cycle by increasing vegetation, increasing infiltration and groundwater recharge, increasing evapotranspiration, and reducing stormwater runoff and greenhouse gas emissions. We start this chapter with a brief discussion on urban greenspaces in general, and then we define urban agriculture and discuss its role as a beneficial greenspace, its differing forms, and its water needs. We conclude our discussion on urban agriculture with a review of the literature on rainwater harvesting for urban agriculture. Our chapter then focuses on a case study – rainwater harvesting potential for the City of Roanoke, Virginia, USA. We review the state of urban agriculture in Roanoke and calculate the potential volume of rainwater that could be harvested and resultant reduction in stormwater flow and greenhouse gas emissions.

## **2 Urban Agriculture Is an Urban Greenspace**

### ***2.1 Urban Sustainability and Greenspaces***

Urban initiatives to reduce ecological footprints, i.e., the impact of human activities, and move toward sustainability include reducing energy use, enhancing water and air quality, and increasing greenspaces. A greenspace is defined as “land that is partly or completely covered with grass, trees, shrubs, or other

vegetation” [18]. Greenspaces positively affect the health and welfare of both human and wildlife populations residing in urban areas [19–23]. Examples of greenspaces’ positive benefits include:

- Generating of ecosystem services [24–26]
- Contributing to biodiversity [21, 25, 27]
- Reducing air pollution and increasing air circulation [21, 25, 27, 28]
- Reducing stormwater runoff, increasing groundwater recharge, and improving water quality [12, 21, 25, 27, 29]
- Reducing the urban heat island effect [21, 25, 30]
- Generating health benefits from environmental improvements and also from increased physical exercise and stress reduction for urban residents [21, 22, 25]
- Increasing social interaction and a sense of community among urban residents [21, 22, 25, 31]

## 2.2 *Urban Agriculture*

Within an urban area, a greenspace “functions as productive green areas that are able to deliver useful products (wood, fruits, compost, energy, etc.) as a result of urban green maintenance or construction” [25]. Urban agriculture is “the growing, processing, and distribution of food and nonfood plant and tree crops and raising of livestock, directly for the urban market, both within and on the fringe of an urban area” [32]. Urban agriculture is a productive use of green areas and clearly provides benefits beyond those provided by other greenspaces, for example, contributions to food security through production of fresh, nutritious fruits and vegetables, economic opportunities from selling agricultural products or from releasing income which can be used elsewhere [33, 34], and nurturing a sense of place [35, 36].

Furthermore, although urban agricultural productivity depends upon the same variables as rural agriculture, i.e., soils, length of growing season, water availability, and solar insolation, studies have shown that urban agriculture’s output is greater in kilograms per unit area than rural agriculture [37, 38]. Urban agriculture’s higher production rates are related to more efficient use of space and water (e.g., using horizontal and vertical spaces, smaller plots), producing crops with shorter life cycle, and multi-cropping [33, 39–41].

Urban agriculture is not a new phenomenon; it has been practiced since urban areas were first established [25]. Urban agriculture history in the United States (US) exceeds 100 years [42], intensifying during periods of national crisis, such as both World Wars and the Great Depression [7, 10, 43, 44]. Today, it is experiencing a revival because of current economic conditions, the recognition of benefits of locally grown food, the ability to contribute to urban sustainability, and the potential to alleviate food insecurity in low-income urban areas [10, 43, 45].

Worldwide, one in nine people suffer from chronic malnutrition due to food insecurity [46]. Food insecurity also exists in the United States – more than one in

ten households suffer from food insecurity [47, 48]. Many of the food-insecure people live in urban areas since the majority of people now live in urban versus rural areas. Thus urban agriculture has become a major focus across the world [49], and it's estimated that about 800 million people participate in urban food production [50]. In a study of 15 developing countries, FAO [51] estimated up to 70 % of urban households participate in agriculture [the rates vary by country – the lowest percentage in Indonesia (around 10 %) and the highest in Vietnam (70 %)]. These percentages increase dramatically (5–40 percentage points) when one examines those households in the lowest 20 % of average incomes [51]. While urban agriculture covers production of both plants and animals for food, the predominant form is plant production for household subsistence.

### 2.3 Urban Agriculture's Water Needs

Land availability, access to water, and quality of soil are important factors for urban agriculture. The amount of water needed for urban agriculture depends on the type of food produced, but more importantly upon form and size of production [52].

#### 2.3.1 Urban Agriculture Forms

Urban agriculture ranges in size from micro-gardening (i.e., containers on balconies and patios – Fig. 1), to mesoscale (i.e., shared garden plots), to macroscale (i.e., urban farms) [53]. *Home gardens*, usually identified as backyard gardens, are the most common form of urban agriculture (Fig. 2) [33, 54] and usually involve a household growing food for its own consumption on land area adjacent to their residence [54].

*Community gardens* (Fig. 3) are becoming a prevalent form of urban agriculture all over the world [54, 55] and are broadly defined as a community of people, sharing a relationship, cultivating an area of land. Each community member gardens an individual plot and shares in maintenance of common areas. In most instances, the land is owned by an entity (local governments, churches, nonprofit organizations) which allows the community to use the land for gardening [44, 54, 56]. The broad heading of community gardens can also include allotment or noncommercial gardens [54] and schoolyard gardens [31].

*Urban farms* (Fig. 4) are the largest (in areal extent) of all urban agriculture forms [33], with an identifying characteristic as a for-profit business. This urban agriculture form can include greenhouses, orchards, rooftop gardens, and community-supported agriculture, usually owned by a family or commercial operation.

Each of these various forms does have specific characteristics, as briefly described above; however, these characteristics are not exclusive to each. For example, people gardening in containers on patios, balconies, and home gardens

**Fig. 1** Container garden on a patio in Blacksburg, Virginia, USA (Photo: First author, 2015)



may sell their products for profit. Orchards can be planted by municipalities for harvesting and consumption by local residents, and some urban farms exist as parts of nonprofit food banks.

### 2.3.2 Water for Urban Agriculture

While urban agriculture is touted as a greenspace that should be included as part of urban sustainability planning, in most cases, potable water is often used for plant and crop irrigation (Fig. 5). However, with urban areas expanding, continued use of potable water for agriculture presents many obstacles – competing demands for urban water; lack of available water resources, especially in arid or semiarid regions; and escalating costs [52]. Aiming to quantify the exact demand on





**Fig. 2** Home garden in a backyard, Blacksburg, Virginia (Photo: First author, 2015)



**Fig. 3** Day Avenue Community Garden, Roanoke, Virginia, USA (Photo: Third author, 2015)

municipal water supplies for expansion of urban agriculture in four Australian cities, Ward et al. [52] estimated water demand for a theoretical garden using water requirement and actual crop yield information from rural agriculture. They noted that household water demand would increase significantly, along with overall household expenses, and therefore alternative sources of water for urban agriculture should be considered. In addition, FAO [51] recommends targeting two research areas for urban agriculture water use – (1) reusing treated or partially treated wastewater, and (2) harvesting rainwater. Chapter “[Urban Wastewater for](#)



**Fig. 4** A portion of Heritage Point Urban Farm, Roanoke, Virginia, USA (Photo: Third author, 2015)



**Fig. 5** Potable water supply for Growing Goodwill Community Garden, Roanoke, Virginia, USA (Photo: Third author, 2015)

[Sustainable Urban Agriculture and Water Management in Developing Countries](#)” (of this book) discusses uses of wastewater in the context of urban agriculture, so we do not discuss that topic here.

Rainwater harvesting collects water runoff from impervious surfaces and, in some instances, floodwaters during rain events. Impervious surfaces can include rooftops, roads, and parking lots. Throughout existing urban agriculture literature, many authors cite uses of rainwater harvesting for irrigation purposes (e.g., [33, 57, 58]), yet scientific studies of rainwater harvesting for urban agriculture use are sparse.

The few studies identified on this topic vary in design and purpose, usually related to specific study site characteristics. Three such studies are summarized here.

Lupia and Pulighe [59] performed a similar urban agriculture water need assessment as [52] above, but quantified water demand for existing home gardens in Rome, Italy. They also calculated rainwater volume that could be harvested and used as irrigation water for these home gardens. Lupia and Pulighe [59] outline procedures for calculating rainwater harvesting potential similar to what we will discuss later in our case study, Sect. 3: rainwater harvesting from roof areas of adjacent buildings, calculating rainwater volume, and using a constant to represent the rainwater losses due to splash and evaporation. Their study estimated that (with the exception of vineyards and olive groves) harvested rainwater from roof areas would be adequate to meet water needs for all existing home gardens in Rome.

Redwood et al. [60] conducted a cost/benefit analysis of actual rainwater harvesting and gray water use (not discussed here) for urban farms in Tunisia, an arid region, and a region where recent political instability has disrupted outside food supplies. The study first evaluated the efficacy of a rainwater harvesting system, using a local school as the test site. Rainwater was collected from rooftops and greenhouses via pipes leading to a storage tank. The collected water was then pumped to greenhouses as irrigation for crops produced outside of the normal growing season. Their analysis revealed that installing such systems would create economic benefits for local urban farmers. The authors also conducted a survey of 150 urban farmers, revealing that most relied on their food production to feed their families, and more than half earned income from selling their products. Most importantly, the survey revealed that during an economic crisis, when other urban residents lost income and faced food shortages, urban farmers were able to continue to feed their families. The rainwater harvesting system was subsequently installed at 20 urban farms. Evaluation of these systems is continuing.

Richards et al. [61] constructed two vegetable rain gardens (one lined and one unlined) for subirrigation systems and prepared two control vegetable gardens using surface irrigation at the University of Melbourne, Burnley Campus (Australia). The objective of the study was to evaluate differences in yields and the need for additional irrigation during dry periods over an 18-month period. Rainwater was harvested from a nearby roof and delivered via a pipe to rain gardens where two thirds of the harvested rainwater was directed to the vegetable gardens and the remaining one third was stored in a tank for use as supplemental irrigation

water. Results show that the lined rain garden needed no additional irrigation during dry periods, but the unlined rain garden and the two control vegetable gardens did require more water. Production yields were comparable, except during the winter growing season, but more importantly, the rain gardens reduced the volume and frequency of runoff by more than 90 %.

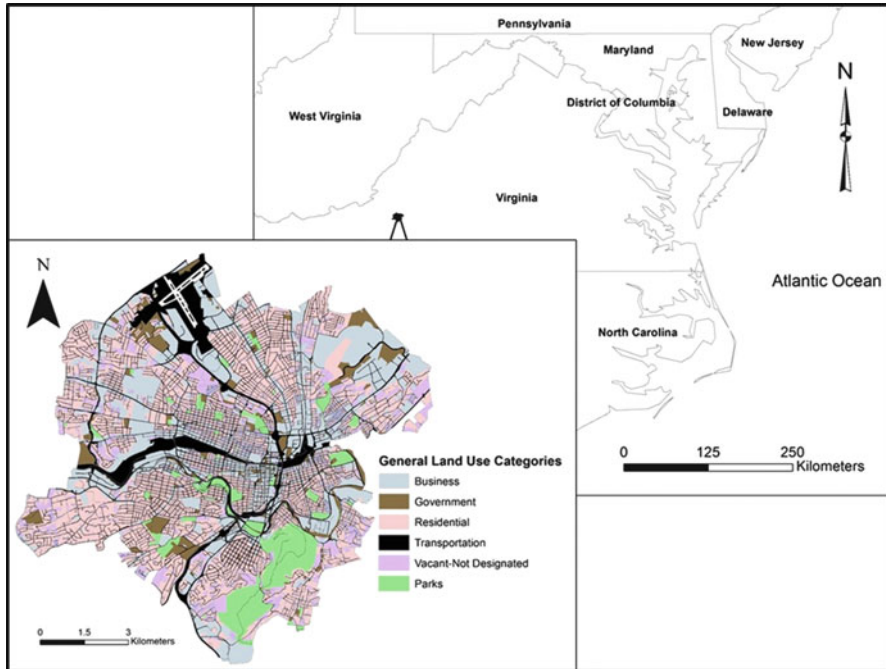
All three rainwater harvesting studies described above use only rainwater harvested from rooftops. It's suggested that rainwater runoff from impervious surfaces such as roads, sidewalks, and parking lots should be avoided in urban agriculture systems. Studies have shown that runoff from these impervious surfaces often contains contaminants such as heavy metals (common pollutants from motor vehicles); polycyclic aromatic hydrocarbons (PAHs), contaminants originating from tires, fuels, and road surfacing materials; and biological pathogens such as fecal coliform and *Escherichia coli* originating from animal waste [57]. These contaminants present human health risks to those consuming food produced and to urban gardeners working in contaminated soils [62–66].

### 3 Case Study

This section of the chapter describes a case study on rainwater harvesting potential for existing and potential urban agriculture sites within the City of Roanoke, Virginia, USA. The first segment provides background information on the study site. We then discuss data needs for input into the three equations that calculate (1) rainwater harvesting potential, (2) energy savings from not using municipal water supplies for irrigation, (3) reductions in stormwater runoff, and (4) reductions in greenhouse gas emissions. We next discuss methods used to identify locations of existing urban agriculture sites, new potential urban agriculture sites, and locations suitable for harvesting rainwater. Lastly, we provide study results for site identification and calculations.

#### 3.1 Study Site

The City of Roanoke, Virginia, USA, the largest city in southwestern Virginia (Fig. 6), is 111 km<sup>2</sup> with a population of 99,428 [67]. The city's land use and commercial sectors are influenced by its history as a transportation hub for rail and road traffic and supporting services and industries. Additional activities include finance, distribution, trade, manufacturing, and healthcare facilities. City of Roanoke area contains 642.5 ha of parks and 96.7 ha of US National Park Service land. Its major land covers include 47.9 % tree canopy [68], 31.9 % impervious surfaces (as calculated by the first author using geospatial analysis), and the remaining land cover comprised of water, grass, bare earth, and some agriculture.



**Fig. 6** Roanoke reference and land use map (Source: City of Roanoke Parcels Shapefile, 2015, as processed by the first author)

Although Roanoke has significant amounts of greenspace (tree canopy cover and park land), annual greenhouse gas (GHG) emissions from the city are estimated at 2,076,700 US tons ( $\sim 1.9 \times 10^9$  kg) of  $\text{CO}_2$  for 2012 [69]. In addition, the city is frequently flooded because of its proximity to the Roanoke River and which is further exacerbated by urban stormwater runoff (Fig. 7). Many segments of the Roanoke River and tributaries flowing within the city are listed as impaired due to contaminants such as *E. coli*, high water temperatures, and heavy metals exceeding Virginia's water quality standards [70].

The city population is supplied by a variety of water sources (Table 1). Electricity consumption for providing public water varies by water source (Table 1). Carvins Cove reservoir's electricity use is significantly less than the United States' average as its drinking water treatment plant uses conventional water treatment methods (coagulation/sedimentation and filtration), and the city's location is downhill from the reservoir which is located in the mountains northwest of the city. However, within the city, approximately 25 % of Carvins Cove water is pumped uphill to some residential areas, increasing energy use about fourfold [71]. Crystal Spring uses a micro-filtration with a disinfection system which is an energy-intensive water treatment process. Spring Hollow uses a newer filtration system with less chemical use, but such systems have much higher energy needs [71]. Appalachian Power Company, Inc. provides energy for the Water Authority, the city, and residents [71]. Fuels used for energy generation are coal (75.6 %), natural gas (14.2 %), and hydro (10.2 %) [72].



**Fig. 7** Example of flooding (from stormwater runoff) on a major thoroughfare – US 460/Orange Avenue (downtown Roanoke is seen on the right behind the overpass) (Source: Public Domain, 2013, image obtained from Roanoke Civic Center Facebook site no longer in use)

**Table 1** Electricity consumption versus water source [71]

Water source	kWh/million gallons	kWh/cubic meter
Carvins Cove reservoir	306.7 (75 % of customers)	0.081
	1306.7 (25 % of customers)	0.345
Crystal Spring	1751.4	0.463
Spring Hollow	5726.4	1.513
Falling Creek	Unknown	Unknown
Private wells	Unknown	Unknown

**Table 2** Precipitation (cm) by month for Roanoke, Virginia, June 2014–May 2015 [74]

	Jan	Feb	Mar	Apr	May	June	July	Aug	Sept	Oct	Nov	Dec
Year	2015	2015	2015	2015	2015	2014	2014	2014	2014	2014	2014	2014
Cm	7.4	7.3	8.8	8.6	10.3	9.7	10.3	9.0	9.9	7.3	8.6	7.5

Roanoke receives an average of 109.7 cm (43.2 in.) of precipitation per year [73]. Total rainfall per month is fairly uniform throughout the year, with just slightly more during the months of May–September, most of Roanoke’s growing season (Table 2).

Roanoke’s urban agriculture scene includes community gardens, home gardens, and urban farms operated by two local food organizations. The Roanoke Natural Foods Co-op operates one urban farm at Heritage Point (Fig. 4) in northeast Roanoke and two local natural food stores. The farm’s land, purchased by the Co-op in 2012, approximately 10.1 ha, is located near an industrial park [75]. The second urban farm, Lick Run, is located at the site of a defunct nursery within a residential neighborhood. It was purchased by a private citizen in 2010 with the intention of starting an urban farm and farmer’s market; portions are now under cultivation (Fig. 8).



**Fig. 8** Lick Run Urban Farm and Community Market, area under cultivation in photo on the left, farm house in photo on the right (Photos: Third author, 2015)



**Fig. 9** Rainwater harvesting systems at Hurt Park Community Garden, photo on the *left* shows a 1500 gal (5.7 m<sup>3</sup>) barrel to the left of the pavilion; photo on the *right* shows a second barrel to the right of the pavilion (Photos: Third author 2013)

The Roanoke Community Garden Association (RCGA) (established in 2008) cultivates several locations. Members of RCGA are environmentally conscious, as all gardens are organic and incorporate rainwater harvesting at most locations (Fig. 9). Mountain View Community Garden (established 2013) and Growing Goodwill Community Garden (established 2014) are the most recent gardens. The land for Mountain View is owned by the city but leased to RCGA for 5 years; food production started in 2014. The newest garden, Growing Goodwill Community Garden (Fig. 5), is located on property owned by Goodwill Industries of the Valleys; food production started in 2015, and additional cultivation plans include a food forest (i.e., orchard). Many RCGA gardeners (~30 %) are either refugees or recent immigrants. RCGA plans for future locations across the city, the next to be sited on land owned by a church [76]. RCGA has performed exceptionally well in siting their community gardens to assist with food security in lower-income populations – all of their community gardens are located in areas with poverty rates that exceed US national and Commonwealth of Virginia averages [77].

Home gardening is practiced within the city; these locations are identified in Sect. 3.2.

## 3.2 Methods

For our case study, we intend to show how much rainwater can be harvested for existing urban agriculture within the City of Roanoke and for potential new urban agriculture sites. Hereinafter, we refer to the potential amount of harvested rainwater as usable rainwater volume (URV). For calculation of URV, we use the rooftop areas of all structures located within the same parcel as the urban agriculture plot. We used rooftop areas only because of concerns, noted in Sect. 2.3.2, regarding potential contaminants from impervious surfaces on the ground – such stormwater runoff could contain pollutants from vehicle emissions (e.g., roads, sidewalks, or parking lots). As noted, contaminants from said runoff could accumulate in soils or crops, thus creating a potential human health hazard.

We also include scenarios for two large existing urban agriculture locations (Growing Goodwill Community Garden and Heritage Point Urban Farm) for which URV calculations include nearby commercial/industrial rooftops. For our final calculation of URV, we perform analysis based upon a land inventory of open areas for potential urban agriculture sites for Roanoke completed by Parece and Campbell [78].

In addition, we will calculate reductions in greenhouse gas (GHG) emissions that would occur from substituting harvested rainwater for irrigation instead of public water supplies. These scenarios calculate not only conservation of water and energy by harvesting rainwater but also reductions in stormwater runoff that could be achieved.

### 3.2.1 Important Equations

Variables that are important to our case study include the volume of rainwater that can be harvested, roof areas of available buildings, amount of energy used to treat and deliver potable water, and amount of greenhouse gas emissions from the fuel source for the electricity-generating power plant.

To calculate the amount of usable rainwater volume, from [79], we use the following equation:

$$\text{URV (m}^3\text{/time period)} = \text{Roof-Area (m}^2\text{)} \times \text{Average Rainfall (m/time period)} \times C \quad (1)$$

The variable  $C$ , in Eq. 1, is collection efficiency – usually 0.8 – which allows for loss from splash and evaporation [79]. Again, this equation not only estimates rainwater harvesting ability, it also provides the volume reduction in stormwater runoff and the volume reduction in potable water use.

Using the reduction in potable water use, we can also calculate the amount of energy conserved from not using treated potable water and the resultant reduction in GHG, two very important factors in improving sustainability of urban areas. These two amounts are calculated from the following two equations [79]:



**Table 3** Carbon dioxide emissions from electric power generation [80]<sup>a</sup>

Fuel type	Carbon dioxide output rate (grams per kWh)
Coal	960.3
Natural gas	596.0
Petroleum	868.6
Hydroelectric	10.0

<sup>a</sup>Kloss [80] reports pounds per kWh; we converted to grams per kWh (1 lb = 453.592 g)

Energy Conserved (kWh)

$$= (\text{Potable Water Saving (m}^3\text{)} \times \text{Estimated Energy Use (kWh/m}^3\text{)}) - \text{Indoor/Outdoor Pump Energy Need (kWh)} \quad (2)$$

$$\text{CO}_2\text{emissions (g)} = \text{Energy Conserved (kWh)} \times \text{CO}_2\text{output rate (g/kWh)} \quad (3)$$

An input to Eq.3 is the CO<sub>2</sub> output rate, which depends on the fuel source for the electricity-generating power plant. We are using amounts as reported in [80] (Table 3).

### 3.2.2 Identifying Urban Agriculture Within Roanoke

First, we mapped the locations, using geographic information systems (GIS) software, of both urban farms and all community gardens, using information from the Roanoke Community Garden Association's website, 2011 Virginia Base Mapping Program (VBMP) aerial imagery, site visits to locations, and the city's parcels shapefile.

For home gardens, we examined 2011 VBMP aerial imagery displayed in GIS, creating polygons for each site identified. The VBMP imagery was obtained during early March, leaf-off [81], so it was sometimes difficult to distinguish between a dormant plot (no current crop growth) and a bare tract of land (see left of Fig. 10). So, we also used Google Earth™ as a cross-reference. The most recent images in Google Earth™ are National Agriculture Imagery Program (NAIP) aerial imagery taken in June 2012; thus, for instances of actual urban agriculture, a bare plot in the 2011 March imagery was seen as rows of crops (right of Fig. 10).

### 3.2.3 Identifying Roof Area for Existing Urban Agriculture

To identify the area of rooftop impervious surfaces within each parcel containing urban agriculture, we first intersected the shapefile for urban agriculture with the city's parcel file. Then we used the selected parcels to identify those structures (from the city's buildings shapefile) that were located within each parcel. We



**Fig. 10** Example of three bare plots in residential areas – 2011 VBMP aerial imagery (*left*) – the same plots in Google Earth™ display of 2012 NAIP imagery (*right*) clearly show that these plots are cultivated



**Fig. 11** Mountain View Community Garden, shed and pavilion (Photos: First author, 2015)

verified structures against the same aerial photos used in the home garden identification, to ensure that we had identified all structures; we included houses, garages, sheds, and gazebos.

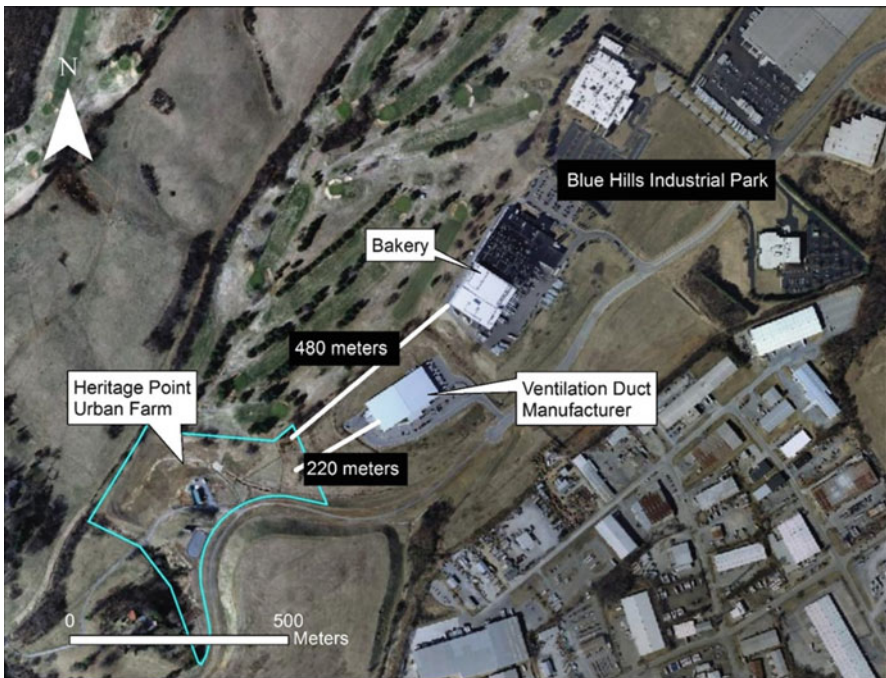
In a few instances, we measured structures for rooftop areas. Most specifically, neither Mountain View Community Garden (Fig. 11) nor Growing Goodwill Community Garden appears on either aerial photos (2011 and 2012) because these gardens were established (2013 and 2014, respectively) after the images were obtained.

Additionally, Growing Goodwill Community Garden has only a shed within its boundaries but is located in very close proximity to one of the Goodwill donation centers (Fig. 12, in the background). As stated under Sect. 3.1, plans for this garden include a food forest, so its irrigation needs reach beyond that of a community garden that raises only cultivated crops. Larger rainwater harvesting systems (such as those discussed in chapter “[Sustainable Water Management in Green Roofs](#)”) could be established for this location. As such, we used both the shed roof area and the donation center’s roof area to calculate URV.

A similar situation applies for Heritage Point Urban Farm (a very large urban farm of 10.1 ha); irrigation needs exceed what can be generated from harvesting rainwater from roofs of buildings and greenhouses on the farm’s premises.



**Fig. 12** Goodwill Donation Center (building in the background) near the Growing Goodwill Community Garden (Photo: First author 2015)



**Fig. 13** Heritage Point Urban Farm and distance to commercial buildings within the industrial park (Source: VBMP, 2011)

But since the farm is located downhill from an industrial park, rainwater could be harvested from roofs of commercial buildings just up the road (Fig. 13).



**Fig. 14** Erosion on Heritage Point Urban Farm’s property caused from unchanneled stormwater runoff from the industrial park’s buildings and parking lots (Photo: First author 2013)

Furthermore, stormwater runoff is actually directed from this industrial park downhill toward the farm, causing considerable erosion on the farm property (Fig. 14). So, if we include the two commercial buildings closest to the farm – a ventilation duct manufacturer and a bakery – in our calculations, URV will increase and erosion would be reduced or eliminated.

### 3.2.4 Identifying Roof Area for Potential Urban Agriculture Sites

For the City of Roanoke, Parece and Campbell [78] completed a land cover and land use analysis to determine if any land was open, available, and potentially suitable for new urban agriculture sites. From the analysis, they calculated that 2311.6 ha of open areas have potential for home gardens, community gardens, orchards, and urban farms. However, not all of these open areas can be placed under cultivation because portions of land available for urban agriculture would need to be used for access, equipment storage, and space for social interaction and to house rainwater harvesting equipment. In addition, not all locations identified by Parece and Campbell [78] were within parcels that contained structures – many hectares were vacant parcels with no structures – constituting highway cloverleaves, roadway and median strips, and non-parcel areas within residential neighborhoods.

As such, for this specific analysis, we use a percentage of the potential area (2311.6 ha) to estimate the roof area from which rainwater can be harvested. To determine what percent to use, we took the total rooftop impervious surface area as calculated under Sect. 3.2.2 above (including the commercial roof areas added for the Goodwill Donation Center, the ventilation duct manufacturer, and the bakery) divided by the total area of existing urban agriculture. We used all roof areas as many

of the potential urban agriculture locations identified by Parece and Campbell [78] included urban farms and orchard locations that would benefit from a larger volume of harvested rainwater which could be collected from nearby commercial buildings.

### 3.2.5 Calculating Usable Rainwater Volume (URV)

Using roof areas (in  $m^2$ ) identified under Sect. 3.2.3 and the amount of annual and monthly precipitation amounts (in m) identified under Sect. 3.1 we used Eq. (1) to calculate URV (in  $m^3$ ) both annually and for the growing season only (April through October), for all existing urban agriculture sites.

Using the roof area (in  $m^2$ ) identified under Sect. 3.2.4 and the amount of annual precipitation (in m) identified under Sect. 3.1 we used Eq. (1) to calculate URV (in  $m^3$ ) annually for potential new urban agriculture sites.

### 3.2.6 Calculating Reduction in Greenhouse Gas (GHG) Emissions

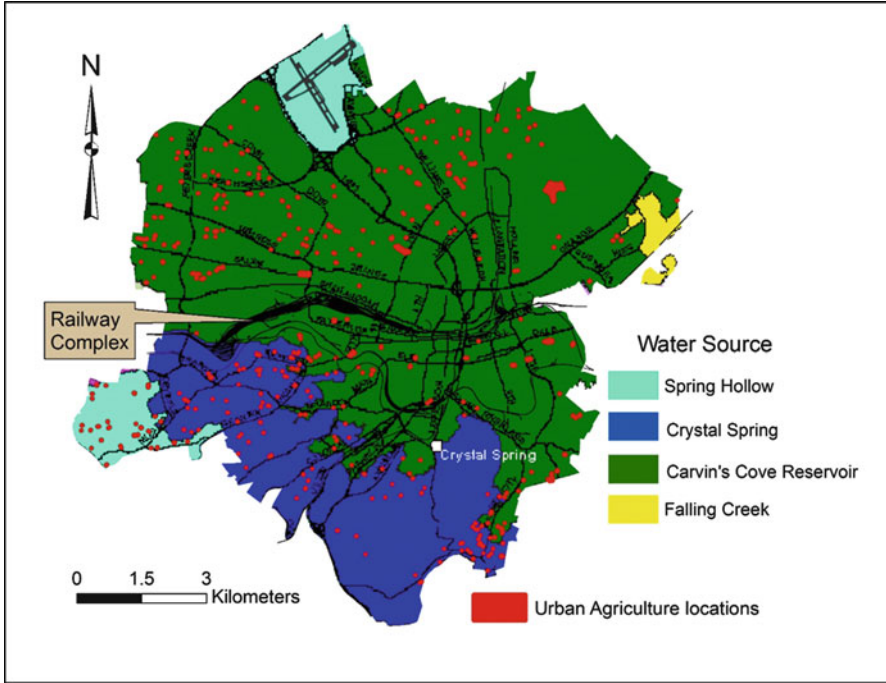
To calculate reduction in greenhouse gas emissions related to energy reduction achieved from using harvested rainwater instead of public water supplies for existing urban agriculture locations, we first identified the public water source for each site. To accomplish this, we downloaded the most recent water quality report from the Western Virginia Water Authority [82]; within this document, a thematic map of the city identifies sources providing water for different areas of the city. We georeferenced this map in GIS, using the city boundary and streets shapefiles as references. We then overlaid the existing urban agriculture shapefile on this thematic map and identified each existing urban agriculture site's water source.

We identified the portion of URV (in  $m^3$ ) for each water source and, using Eq. (2), calculated the amount of energy that would have been used had the same amount of water originated from the public water supply. Finally, we took the energy use and calculated the amount of carbon dioxide (in kg) for each fuel source (using Eq. 3), based on values from American Electric Power (as noted under Sect. 3.1 – coal (75.6 %), natural gas (14.2 %), and hydroelectric (10.2 %)), and estimated grams per kWh for each fuel source, as noted by [80].

## 3.3 Results

### 3.3.1 Locations of Existing Urban Agriculture and Its Water Source

We identified 461 parcels with active urban agriculture within the City of Roanoke – including the two urban farms, all community gardens, and all home gardens (Fig. 15). The Carvins Cove reservoir delivers water for 306 locations, including both urban farms and all the community gardens. Spring Hollow is the source for



**Fig. 15** Locations of existing urban agriculture and their source of water (Source of thematic water source map: Western Virginia Water Authority, 2015)

32 home garden locations. Crystal Spring is the source for 123 home gardens. Falling Creek is not a water source for any existing urban agriculture.

### 3.3.2 Rooftop Area Used to Calculate Usable Rainwater Volume (URV)

As Table 4 shows, 788 structures were identified within the same parcels that contain the existing urban agriculture locations. This table also provides results of the roof area calculation (81,805.2 m<sup>2</sup>), the division of the existing locations and structures by water source, and the total hectares of urban agriculture by water source.

**Table 4** Total number of parcels containing existing urban agriculture, total hectares, number of structures, and total roof area (m<sup>2</sup>) by water source

Water source	No. of parcels containing urban agriculture	Area of urban agriculture in all parcels (ha)	No. of structures within each parcel	Roof area (m <sup>2</sup> )
Carvins Cove	306	15.6	553	53,854.3
Crystal Spring	123	1.6	184	21,113.0
Spring Hollow	32	0.6	51	6837.9
Total	461	17.8	788	81,805.2

**Table 5** URV (m<sup>3</sup>) for existing urban agriculture locations by structures contained within the same parcel as the plot

Water source	Roof area (m <sup>2</sup> ) (from Table 4)	URV (m <sup>3</sup> ) annually (using Eq. 1)	URV (m <sup>3</sup> ) growing season only (using Eq. 1)
Carvins Cove (75 % of customers)	40,390.7	35,446.9	21,035.5
Carvins Cove (25 % of customers)	13,463.6	11,815.7	7011.8
Crystal Spring	21,113.0	18,528.8	10,995.7
Spring Hollow	6837.9	6000.9	3561.2
Total	81,805.2	71,792.2	42,604.2

### 3.3.3 Usable Rainwater Volume (URV) for Existing Urban Agriculture

For those structures contained within the same parcel as the existing urban agriculture location, Table 5 shows the URV, by water source. If harvested throughout the year, the total amount is 71,792.2 m<sup>3</sup>, or if only harvested during the growing season (April through October), the amount is 42,604.2 m<sup>3</sup>. Using Crystal Spring, as an example of our calculations and as inputs for Eq. 1:

$$21,113.0 \text{ m}^2 \times 1.097 \text{ m} \times 0.8 = 18,528.8 \text{ m}^3 \quad (1)$$

Table 6 shows the results for the additional analysis for Growing Goodwill Community Garden. With only the shed roof area, total annual URV is 15.9 m<sup>3</sup>. If we add the roof area of the nearby donation center, the URV amount increases substantially to 88,502.2 m<sup>3</sup>. Since orchards are to be included in this area, water need exists for the entire year, not just the growing season.

Table 7 provides the results for the URV potential for Heritage Point Urban Farm, annually. Since greenhouses and orchards are housed at this urban farm, water need exists for the entire year, not just the growing season. URV for just the roof area of the farm buildings is 410.3 m<sup>3</sup>. If we include the ventilation duct manufacturer building's roof area, URV increases significantly by 77,917.2 m<sup>3</sup>.

**Table 6** URV, annually, for Growing Goodwill Community Garden

Building	Roof Area (m <sup>2</sup> )	Annual rainfall (m)	URV (m <sup>3</sup> )
Shed	18.1	1.097	15.9
Donation center and shed	100,845.7	1.097	88,502.2

**Table 7** URV, annually, for Heritage Point Urban Farm

	Roof area (m <sup>2</sup> )	Annual rainfall (m)	URV (m <sup>3</sup> )
Farm buildings	467.5	1.097	410.3
Duct manufacturer	88,784.4	1.097	77,917.2
Bakery	232,807.6	1.097	204,312.0
Total potential URV for all roof areas			282,639.4

If we include both the duct manufacturer's building's roof area and the bakery's roof area, URV increases to 282,639.4 m<sup>3</sup>.

### 3.3.4 Usable Rainwater Volume (URV) for Potential Urban Agriculture Sites

Total roof area calculated for the first three scenarios above is 504,710.4 m<sup>2</sup>; total existing urban agriculture is 17.8 ha or 178,000 m<sup>2</sup>. Roof area represents 280 % of that total area. Potential urban agriculture totals 2311.6 ha or 23,116,000 m<sup>2</sup>. It is unreasonable to assume that 280 % of this area would be available as roof areas for harvesting of rainwater. As such, we will be conservative in our estimate of roof area available for potential rainwater harvesting for new potential urban agriculture sites. Using 25 % as the potential roof area within the potential urban agriculture sites, we calculate 5,779,000 m<sup>2</sup> of potential roof area for rainwater harvesting or a URV of 5,071,650.4 m<sup>3</sup>.

### 3.3.5 Calculations of GHG Emission Reduction

Table 8 shows energy required if potable water, equal to the amount of URV, was used for irrigation. We calculated these amounts, within this table, using Eq. 2, e.g., annual URV (from Table 5) for Crystal Spring equals 18,528.8 m<sup>3</sup>. Thus, the annual kWh per m<sup>3</sup> for Crystal Spring is 0.463 (from Table 1).

$$8,578.8 \text{ kWh} = 18,528.8 \text{ m}^3 \times 0.463 \text{ kWh/m}^3 \quad (2)$$

Therefore, using harvested rainwater for irrigation, instead of potable water, for the Crystal Spring water source, saves 8578.8 kWh each year. We did not calculate the



**Table 8** Calculation of total energy conserved (kWh/m<sup>3</sup>) by water source – annually and for the growing season only

Water source	URV annually (m <sup>3</sup> ) (from Table 5)	URV (m <sup>3</sup> ) growing season only (from Table 5)	kWh/m <sup>3</sup> (from Table 1)	Total kWh annually	Total kWh growing season only
Carvins Cove (75 %)	35,446.9	21,035.5	0.081	2871.2	1703.9
Carvins Cove (25 %)	11,815.7	7011.8	0.345	4076.4	2419.1
Crystal Spring	18,528.8	10,995.7	0.463	8578.8	5091.0
Spring Hollow	6000.9	3561.2	1.513	9079.4	5388.1
Total	71,792.2	42,604.2	–	24,605.8	14,602.0

**Table 9** Potential reduction in CO<sub>2</sub> emissions (kg) annually and for the growing season only, by fuel source and in total

Fuel source for Roanoke (from Sect. 3.1)	Total kWh annually (Table 8)	CO <sub>2</sub> emissions (kg) annually	Total kWh growing season (Table 8)	CO <sub>2</sub> emissions (kg) growing season
Coal (75.6 %)	18,602.0	17,863.5	11,039.1	10,600.9
Natural gas (14.2 %)	3494.0	2082.4	2073.5	1235.8
Hydroelectric (10.2 %)	2509.8	25.1	1489.4	14.9
Total	24,605.8	19,971.0	14,602.0	11,851.6

energy usage for pumping of harvested rainwater as the energy could be produced using renewal sources such as wind or solar.

For all parcels with existing urban agriculture locations and structures within the same parcels, the reduction in CO<sub>2</sub> emissions is 11,851.56 kg for rainwater harvested only during the growing season (May–October) and 19,971.06 kg if rainwater is harvested throughout the entire year (Table 9). These amounts were calculated by using the kWh usage values from Table 8 for each fuel source (as noted under Sect. 3.1) and the CO<sub>2</sub> emissions per kWh from Table 3, as inputs to Eq. 3. As an example:

$$\begin{aligned} \text{Total kWh use, annually, for coal is } 75.5\% \text{ of } 24,605.8 &= 18,602.0 \\ 18,602.0 \text{ kWh} \times 960.3 \text{ g/kWh} &= 17,863.5 \text{ kg/year.} \end{aligned} \quad (3)$$

Table 10 provides the CO<sub>2</sub> emission reduction for Growing Goodwill Community Garden, for the shed roof only and also if we include the commercial roof areas.

Table 11 provides the results for Heritage Point Urban Farm, for the farm buildings only. If we include the commercial building roof areas, an additional 5817.96 kg/year and 18,581.49 kg/year, respectively, of carbon dioxide emissions is reduced.

**Table 10** Potential reduction in CO<sub>2</sub> emissions, Growing Goodwill Community Garden scenario, each year

Fuel source for Roanoke (from Sect. 3.1)	Shed only		Shed and Goodwill store	
	Total kWh	CO <sub>2</sub> emissions (kg) (Eq. 3)	Total kWh (Eq. 2)	CO <sub>2</sub> emissions (kg) (Eq. 3)
Coal (75.6 %)	Negligible		5420.49	5205.30
Natural gas (14.2 %)			1018.13	606.81
Hydroelectric (10.2 %)			731.34	7.3
Total	1.29		7169.96	5819.4

**Table 11** Potential reduction in CO<sub>2</sub> emissions, Heritage Point Urban Farm scenario, each year

Fuel source for Roanoke (from Sect. 3.1)	Farm buildings only		Farm buildings, duct manufacturer, and bakery	
	Total kWh (Eq. 2)	CO <sub>2</sub> emissions (kg) (Eq. 3)	Total kWh (Eq. 2)	CO <sub>2</sub> emissions (kg) (Eq. 3)
Coal (75.6 %)	25.12	24.13	17,307.71	16,620.59
Natural gas (14.2 %)	4.72	2.81	3250.92	1937.55
Hydroelectric (10.2 %)	3.39	0.03	2335.17	23.35
Total	33.23	26.97	22,893.79	18,581.49

## 4 Conclusions and Recommendations for Additional Research

Our study shows that, for the City of Roanoke, Virginia, USA, a significant amount of rainwater – 442,933.8 m<sup>3</sup>/year – could be harvested from adjacent rooftops to provide irrigation needs for existing urban agriculture. This amount also represents the volume of stormwater runoff that could be reduced if we were to use the harvested rainwater for irrigation, a significant volume in light of Roanoke’s flooding problems. In addition, this effort would reduce the use of municipal water supplies, energy used to provide that water, and emissions of greenhouse gases. Our methods can be used to estimate similar projections for any other urban area, as has similarly been accomplished for Rome, Italy [59].

Our study does not address if these savings are adequate to meet the water needs of urban agriculture, as agricultural needs are highly dependent upon crop type and timing of rainfall. Estimating Roanoke’s water needs for existing urban agriculture is difficult because we do not have knowledge of actual crops grown in an individual plot. Roanoke is located in a water-rich and agriculturally viable area, so the potential diversity of crops produced likely puts such comprehensive estimates for all crop production beyond reasonable capabilities. However, this task will require further consideration when addressing rainwater harvesting abilities of urban areas situated in arid and semiarid regions.

Additionally, we have used average rainfall rates for the entire city. We should note that urban weather stations are often sparse, unevenly distributed, and that rainfall across a specific urban area can be extremely variable [83]. Thus, the effort

to estimate the match between urban agriculture's water needs and availability of usable rainwater volume should be accomplished in the context of urban climatology research. Likewise, our calculations are based on local historical rainfall data and do not consider deviations that may result from climate change. Additional data quantified in conjunction with climate research could be used in identifying the right crops for the right location in order to achieve full agricultural potential.

Studies to quantify potential rainwater harvesting volume are extremely sparse.

But geospatial technologies (i.e., GIS, remote sensing, and GPS) and the widespread availability of aerial imagery of the world's urban regions and of climate data allow for the identification of existing urban agriculture, available rooftop areas for rainwater harvesting potential, water flows, water sources, and calculation of URV and GHG. As such, these values could be estimated for any urban area, worldwide.

Future research should be based upon implementation of rainwater harvesting systems at a variety of scales (see chapter "[Sustainable Water Management in Green Roofs](#)"), to include control garden plots designed without such systems, measurements of the volume and quality of rainwater harvested, records of the volume and nutritional viability of crops produced from such systems, and reporting of actual empirical evidence of diversion of stormwater runoff from said implementation.

**Acknowledgments** This research was financially supported by Virginia Space Grant Consortium 2014/2015 Graduate Research Fellowship. This publication was developed under STAR Fellowship Assistance Agreement No. FP-91769301-0 awarded by the US Environmental Protection Agency (EPA). It has not been formally reviewed by EPA. The views expressed in this publication are solely those of Tammy Erlene Parece and coauthors. US EPA does not endorse any products or commercial services mentioned in this publication.

## References

1. Hooke RL, Martin-Duque JF (2012) Land transformation by humans: a review. *GSA Today* 22(12):4–10
2. Knigge L (2012) Urban regions and localized food systems: 21st century innovations. In: Stoltman J (ed) *21st century geography: a reference handbook*. Sage, Los Angeles, pp 563–573
3. Younos T, Parece TE (2012) Water use and conservation. In: Stoltman J (ed) *21st century geography: a reference handbook*. Sage, Los Angeles, pp 447–456
4. United Nations (2015) *World population prospects: the 2015 revision*. Department of Economic and Social Affairs, Population Division, New York
5. United Nations (2014) *World urbanization prospects: the 2014 revision*. Department of Economic and Social Affairs, Population Division, New York
6. World Bank (2013) *Urban agriculture: findings from four city case studies*. World Bank, Washington, DC
7. Deelstra T, Girardet H (2000) Urban agriculture and sustainable cities. In: Bakker N et al (eds) *Growing cities, growing food: urban agriculture on the policy agenda, a reader on urban agriculture*. Deutsche Stiftung für Internationale Entwicklung, Zentralstelle für Ernährung und Landwirtschaft, Feldafing, pp 43–66

8. Pickett STA et al (2001) Urban ecological systems: linking terrestrial ecological, physical, and socioeconomic components of metropolitan areas. *Annu Rev Ecol Syst* 32:127–157
9. Lincoln Land Institute (2015) Atlas of urban expansion. <http://www.lincolnst.edu/subcenters/atlas-urban-expansion/>. Accessed 19 July 2015
10. Gallagher J (2010) Reimagining Detroit: opportunities for redefining an American city. Wayne State University Press, Detroit
11. McGranahan G, Satterthwaite D (2003) Urban centers: an assessment of sustainability. *Annu Rev Environ Resour* 28:243–274
12. Aitkenhead-Peterson JA, Steele MK, Volder A (2010) Services in natural and human dominated ecosystems. In: Aitkenhead-Peterson J, Volder A (eds) *Urban ecosystem ecology*. American Society of Agronomy: Crop Science Society of America: Soil Science Society of America, Madison, pp 199–226
13. Despommier DD (2010) *The vertical farm*. Thomas Dunne Books, New York
14. Goldstein M et al (2011) *Urban agriculture: a sixteen city survey of urban agriculture practices across the country*. Emory Law, Turner Environmental Law Clinic, Atlanta
15. Mansfield B, Mendes W (2013) Municipal food strategies and integrated approaches to urban agriculture: exploring three cases from the Global North. *Intl Plan Stud* 18(1):37–60
16. McClintock N (2014) A survey of urban agriculture organizations and businesses in the US and Canada: preliminary results. Urban studies and planning faculty publications and presentations, Portland State University
17. Huang D, Drescher M (2015) Urban crops and livestock: the experiences, challenges, and opportunities of planning for urban agriculture in two Canadian provinces. *Land Use Policy* 42:1–14
18. US EPA (2015) What is an open area/green space? <http://www.epa.gov/region1/eco/uep/openspace.html>. Accessed 7 Feb 2015
19. Wheater CP (1999) *Urban habitats*. Routledge, London
20. Nowak DJ (2006) Institutionalizing urban forestry as a “biotechnology” to improve environmental quality. *Urban For Urban Green* 5:93–100
21. Beer AR (2010) Greenspaces, green structure and green infrastructure planning. In: Aitkenhead-Peterson J, Volder A (eds) *Urban ecosystem ecology*. American Society of Agronomy: Crop Science Society of America: Soil Science Society of America, Madison, pp 431–448
22. Kuo FE (2010) *Parks and other green environments: components of a healthy human habitat*. National Parks and Recreation Association, Ashburn
23. Volder A, Watson WT (2010) Urban forestry. In: Aitkenhead-Peterson J, Volder A (eds) *Urban ecosystem ecology*. American Society of Agronomy: Crop Science Society of America: Soil Science Society of America, Madison, pp 227–240
24. Bolund P, Hunhammar S (1999) Ecosystem services in urban areas. *Ecol Econ* 29:293–301
25. van Leeuwen E, Nijkamp P, de Noronha VT (2010) The multifunctional use of urban greenspace. *Intl J Agric Sustain* 8(1/2):20–25
26. Lin BB, Philpott SM, Jha S (2015) The future of urban agriculture and biodiversity-ecosystem services: challenges and next steps. *Basic Appl Ecol* 16(3):189–201
27. Botkin DB, Beveridge CE (1997) Cities as environments. *Urban Ecosys* 1(1):3–19
28. Aitkenhead-Peterson J, Volder A (2010) *Urban ecosystem ecology*. American Society of Agronomy: Crop Science Society of America: Soil Science Society of America, Madison
29. Fisher M (2015) Reducing stormwater runoff with green infrastructure. *Soil Horiz* doi:10.2136/sh2015-56-2-f
30. Lee G, Lee H, Lee J (2015) Greenhouse gas emission reduction effect in the transportation sector by urban agriculture in Seoul, Korea. *Lands Urban Plan* 140:1–7
31. Moore SA et al (2015) School gardens as sites for forging progressive socioecological futures. *Ann Assoc Am Geogr* 105(2):407–415
32. Mougeot LJA (2006) *Growing better cities: urban agriculture for sustainable development*. Internationale Development Research Centre, Ottawa

33. Smit J, Nasr J, Ratta A (2001) Urban agriculture: food, jobs and sustainable cities. The Urban Agriculture Network, New York
34. Bellows AC, Brown K, Smit J (2003) Health benefits of urban agriculture. [http://www.co.fresno.ca.us/uploadedfiles/departments/behavioral\\_health/mhsa/health%20benefits%20of%20urban%20agriculture%20%281-8%29.pdf](http://www.co.fresno.ca.us/uploadedfiles/departments/behavioral_health/mhsa/health%20benefits%20of%20urban%20agriculture%20%281-8%29.pdf)
35. Mok H et al (2014) Strawberry field forever? Urban agriculture in developed countries: a review. *Agron Sustain Dev* 34:21–43
36. White SA (2014) Cultivating the city: exploring the production of place and people through urban agriculture. Three studies from M' Bour, Senegal. PhD dissertation, Michigan State University
37. Wade I (1987) Community food production in cities of the developing countries. *Food Nutr Bull* 9(2):29–36
38. Gittleman M, Jordan K, Brelsford E (2012) Using citizen science to quantify community garden crop yields. *Cities Environ* 5(1), Article 4
39. Yadav P, Duckworth K, Grewal PS (2012) Habitat structure influences below ground bio-control services: a comparison between urban gardens and vacant lots. *Landsc Urban Plan* 104(2):238–244
40. Li L et al (2013) Eco-vegetation construction of the community gardens in US and its implications. *Asian Agric Res* 5(7):92–96
41. Taylor JR, Lovell ST (2015) Urban home gardens in the global North: a mixed methods study of ethnic and migrant home gardens in Chicago, IL. *Renewable Agric Food Syst* 30(01):22–32
42. Lawson LJ (2005) City bountiful: a century of community gardening in America. University of California Press, Berkeley
43. Nordahl D (2009) Public produce: the new urban agriculture. Island Press, Washington, DC
44. Iaquina DL, Drescher AW (2010) Urban agriculture: a comparative review of allotment and community gardens. In: Aitkenhead-Peterson J, Volder A (eds) Urban ecosystem ecology. American Society of Agronomy: Crop Science Society of America: Soil Science Society of America, Madison, pp 199–226
45. Patel IC (1996) Rutgers urban gardening a case study in urban agriculture. *J Agric Food Info* 3(3):35–46
46. FAO, IFAD, WFP (2014) State of food insecurity in the world. FAO, Rome
47. Brown KH et al. (2002) Urban agriculture and community food security in the United States: farming from the city center to the urban fringe. [http://ocfoodaccess.org/wp-content/uploads/2013/08/Urban-Agriculture-Food-Security\\_CFSC-2002.pdf](http://ocfoodaccess.org/wp-content/uploads/2013/08/Urban-Agriculture-Food-Security_CFSC-2002.pdf)
48. Coleman-Jensen A, et al (2011) Household food security in the United States in 2010. USDA food assistance and nutrition research program. <http://www.ers.usda.gov/publications/err-economic-research-report/err125.aspx>
49. FAO (2007) The urban producer's resource book. Food and Agriculture Organization, Rome
50. FAO (2015) Urban agriculture. <http://www.fao.org/urban-agriculture/en/>
51. FAO (2010) Fighting poverty and hunger: what role for urban agriculture? economic and social perspectives. Economic and Social Development Department of the Food and Agriculture Organization of the United Nations, New York
52. Ward JD, et al (2014) The urban agriculture revolution: implications for water use in cities. *Water* February:69–74
53. Pearson L, Pearson L, Pearson C (2010) Sustainable urban agriculture: stocktake and opportunities. *Intl J Agric Sustain* 8(1/2):7–19
54. Drescher AW, Holmer RJ, Iaquina DL (2006) Urban home gardens and allotment gardens for sustainable livelihoods: management strategies and institutional environments. In: Kumar BM, Nair PKR (eds) Tropical home gardens: a time-tested example of sustainable agroforestry. Springer, Dordrecht, pp 317–338
55. Parece TE, Campbell JB A survey of urban gardeners. In: WinklerPrins A (ed) Global urban agriculture: convergence of theory and practice between North and South. CABI (Under Review)
56. Smit J, Nasr J (1992) Urban agriculture for sustainable cities: using wastes and idle land and water bodies as resources. *Environ Urban* 4:141–152

57. Wortman SE, Lovell ST (2014) Environmental challenges threatening the growth of urban agriculture in the United States. *J Environ Qual* 42:1283–1294
58. FAO (2011) Food, agriculture and cities: the challenges of food and nutrition security, agriculture and ecosystem management in an urbanizing world. Food for the cities multi-disciplinary initiative position paper. <http://www.fao.org/3/a-au725e.pdf>
59. Lupia F, Pulighe G (2015) Water use and urban agriculture: estimation and water saving scenarios for residential kitchen gardens. *Agric Agric Sci Procedia* 4:50–58
60. Redwood M, Bouraoui M, Houmane B (2014) Rainwater and grey water harvesting for urban food security in La Soukra, Tunisia. *Int J Water Resour Dev* 30(2):293–307
61. Richards PJ et al (2015) Vegetable rain gardens can produce food and reduce stormwater runoff. *Urban For Urban Green* 14(3):646–654
62. Scheyer JM, Hipple KW (2005) *Urban soils primer*. USDA National Resource Conservation Service National Soils Survey Center, Lincoln
63. Toronto Public Health (2011) *Assessing urban impacted soils for urban gardening: decision support tool – technical report and rationale*. Toronto Public Health, Toronto
64. US EPA (2011) *Brownfields and urban agriculture: interim guidelines for safe gardening practices*. US EPA, Washington, DC
65. Angelone M, Udovic M (2014) Potentially harmful elements in urban soils. In: Bini C, Bech J (eds) *PHEs, environment and human health*. Springer, London, pp 221–252
66. LaCroix CJ (2014) Urban agriculture and the environment. *The Urban Lawyer* 46(2):227–242
67. US Census (2015) Quick facts. <http://quickfacts.census.gov/qfd/states/51/51770.html>. Accessed 29 May 2015
68. Pugh J (2010) *A report on the city of Roanoke’s existing and possible urban tree canopy*. Virginia Department of Forestry, Charlottesville
69. Roanoke (2013) *City of Roanoke 2012 Municipal Greenhouse Gas (GHG) emissions and energy summary*, Roanoke, Virginia. [http://www.roanokeva.gov/85256A8D0062AF37/vwContentByKey/6860F1A26A2F32E585257C4E006D498D/\\$File/Municipal2012.pdf](http://www.roanokeva.gov/85256A8D0062AF37/vwContentByKey/6860F1A26A2F32E585257C4E006D498D/$File/Municipal2012.pdf)
70. Virginia (2010) Department of environmental quality: GIS data sets. <http://www.deq.virginia.gov/ConnectWithDEQ/VEGIS/VEGISDatasets.aspx>
71. McEvoy M (2015) Executive director/wastewater services Western Virginia water authority, Personal Communication
72. American Electric Power Company Inc (2014) 2014 Fact book, 49th EEI financial conference, Dallas <https://www.aep.com/investors/EventsPresentationsAndWebcasts/documents/2014Factbook.pdf>
73. National Oceanic and Atmospheric Administration (NOAA) (2015) Daily climate data. <http://www.erh.noaa.gov/rnk/climate/f6/html/F6.html#ROA>. Accessed 19 June 2015
74. National Oceanic and Atmospheric Administration (NOAA) (2015) Recent temperature and precipitation graphs for Roanoke, Virginia. <http://www.weather.gov/rnk/climatePlotsRoa>. Accessed 19 June 2015
75. Ress D (2013) Roanoke natural food co-op farm fits in at industry park. *Roanoke Times*, Roanoke, 9 June 2013
76. Powell M (2015) Director, Roanoke community garden association, Personal Communication
77. Parece TE, Campbell JB, Serrano E (Pending Publication) *Strategically siting urban agriculture: A socio-economic analysis of Roanoke, Virginia*. Prof Geog
78. Parece TE, Campbell JB (Pending Publication 2017) *Geospatial evaluation for urban agriculture land inventory, Roanoke Virginia USA*. *Intl J Applied Geospatial Res* 8(1)
79. Younos T, et al (2009) *Conventional and decentralized water supply infrastructure: energy consumption and carbon footprint*. American Water Resources Association 2009 Spring specialty conference, Anchorage, Alaska
80. Kloss C (2008) *Managing wet weather with green infrastructure: municipal handbook: rainwater harvesting policies*. US EPA, Washington, DC
81. Virginia (2011) *Virginia base mapping program*. <http://gisvirginia.blogspot.com/2011/03/vbmp-2011-update-march-10>. Accessed 1 Jan 2015

82. Western Virginia Water Authority (2015) Water quality report. <http://www.westernvawater.org/WebMgmt/ywbase61b.nsf/vwContentByKey/N2628RTH805PLESEN>. Accessed 17 June 2015
83. Geiger R, Aron RH, Todhunter P (2003) The climate near the ground, 6th edn. Rowman & Littlefield, Lanham Maryland

# Urban Wastewater for Sustainable Urban Agriculture and Water Management in Developing Countries

Fungai S. Makoni, Oriël M.M. Thekisoë, and Peter A. Mbatì

## Contents

1	Introduction .....	266
2	Urbanisation, Population Growth and Water Scarcity .....	268
3	Urban Agriculture .....	269
3.1	Wastewater Use for Urban Agriculture .....	270
3.2	Extent of Urban Wastewater Use for Urban Agriculture .....	270
4	Wastewater for Urban Agriculture .....	271
4.1	Sources of Wastewater .....	271
4.2	Quality of Wastewater in Urban Environments .....	272
4.3	Key Parameters in Wastewater .....	273
4.4	Health Risks of Wastewater .....	274
4.5	Environmental Risk .....	275
4.6	Benefits of Wastewater Use .....	276
5	Research on Benefits of Wastewater Use to Livelihoods and Food Security .....	277
6	Case Study: Bulawayo, Zimbabwe .....	279
6.1	Study Area .....	279
6.2	Methods .....	280
6.3	Effluent Temperature .....	281
6.4	Effluent pH .....	281

---

F.S. Makoni

South Sudan County Office, SNV Netherlands Development Organization, The Hague,  
The Netherlands

Department of Zoology and Entomology, University of the Free State, Qwaqwa Campus,  
Private Bag x13, Phuthaditjhaba 9866, South Africa

O.M.M. Thekisoë (✉)

Department of Zoology and Entomology, University of the Free State, Qwaqwa Campus,  
Private Bag x13, Phuthaditjhaba 9866, South Africa

Unit for Environmental Sciences and Management, North-West University, Potchefstroom  
Campus, Private Bag x6001, Potchefstroom 2520, South Africa

e-mail: [thekisoë@gmail.com](mailto:thekisoë@gmail.com)

P.A. Mbatì

University of Venda, Private Bag X5050, Thohoyandou, Limpopo Province 0950,  
South Africa



6.5	Effluent Turbidity .....	281
6.6	Effluent Electrical Conductivity .....	282
6.7	Effluent Heavy Metal Level .....	282
6.8	Effluent Faecal Coliform .....	283
6.9	Conclusions from Case Study .....	283
7	Sustaining Wastewater Use for Urban Agriculture: Discussion .....	285
7.1	Policy and Institutional Settings .....	285
7.2	Stakeholder Forum and Participation .....	286
7.3	Capacity Building and Outreach .....	287
7.4	Marketing .....	288
7.5	Creation of Enabling Environment .....	288
8	Conclusions .....	289
	References .....	290

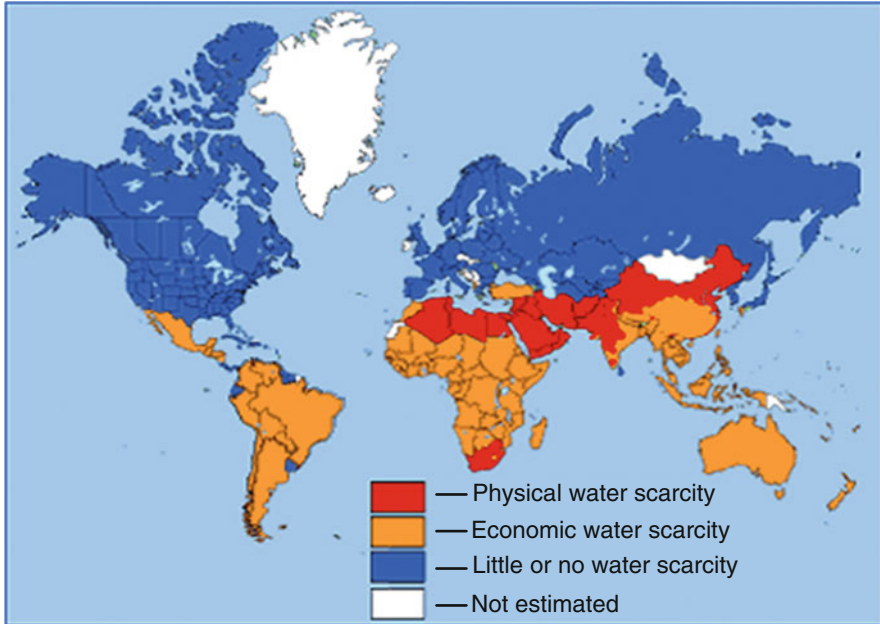
**Abstract** This chapter provides an overview of water scarcity in developing countries and its impact in relation to agricultural food production. We address issues of wastewater generated through domestic/commercial use and its beneficial uses for urban agriculture as an alternative source of irrigation water. We highlight pertinent issues of urban agriculture as one way to bolster urban food supplies whilst enhancing safe disposal of wastewater for environmental and public health consideration. In addition, we provide management strategies based on field experiments for sustainable utilisation of treated domestic wastewater for irrigated agriculture. In conclusion, we deliver evidence of socio-economic benefits of wastewater use for improving livelihoods for urban poor.

**Keywords** Environmental health • Food security • Irrigation • Urban agriculture • Urbanisation • Wastewater

## 1 Introduction

This chapter gives an overview of water scarcity and its impacts in relation to agricultural food production. It attempts to address issues of wastewater generated by domestic/commercial sources and its productive uses for urban agriculture as an alternative source of irrigation water.

Water is a basic resource and necessary for human life for either direct consumption or food production. The world's water exists naturally in different forms and locations in the air, surface and below the ground. It has been estimated that the average per capita availability of water has dropped from 3300 m<sup>3</sup> in 1960 to 1200 m<sup>3</sup> in 2002 [1]. It has been further estimated that by the year 2025 (Fig. 1), many countries will suffer chronic water stress and around 3.5 billion people will experience water stress. It has been estimated that total actual renewable water resources (TARWR) have decreased, and this will especially affect large cities in



**Fig. 1** Projected water scarcity in 2025 [2]

developing countries where there are significant challenges to meet increased water demand [3].

Water scarcity is a gap between available supply and demand of freshwater in a specified domain, under prevailing institutional arrangements (including both resource ‘pricing’ and retail charging arrangements) and infrastructural conditions [4].

Drivers of the perceived water crisis are well documented, and global water demand has been reported to be growing at more than twice the rate of population increase in the last century [2]. In the context of developing countries and in particular urbanisation, water scarcity evidence indicates that the world’s water resources are irregularly distributed and are under pressure from major population change and increased demand. It has been highlighted that the causes of water scarcity are many and interrelated and in most cases it is when demand grows beyond available supply [5]. This has been noted to have resulted in increased competition for water among individuals or groups to capture the scarce resources. The driving forces of water scarcity are [3]:

1. Population growth, particularly in water-short regions
2. Major changes in migration as people move from rural to urban environments
3. Increased demand for food security and socio-economic well-being
4. Increased competition between users and usages
5. Water pollution from industrial, municipal and agricultural sources

Experts have indicated a growing concern on the uncertainty of water availability in many countries, particularly developing countries and, especially, those that will not be able to meet the estimated water demands in 2025, even after accounting for future adaptive capacity. Those that will not be able to meet the demands will be defined as ‘physically water scarce’, whilst those that have sufficient renewable resources, but would have to make very significant investment in water infrastructure to make these resources available to people, are defined as ‘economically water scarce’ [6–8]. According to UN-Water [4], most population growth will occur in developing countries, particularly in regions already experiencing water stress as well as in areas with limited access to safe drinking water and adequate sanitation facilities.

## 2 Urbanisation, Population Growth and Water Scarcity

Urbanisation in the developing world has intensified in the last century and is expected to continue in the coming years. Most population growth is expected to occur in urban and peri-urban areas – areas that surround metropolitan areas and cities – in the developing world [9]. Africa and Asia will urbanise faster than other regions and are expected to double their urban population by 2030. It is estimated that 93 % of urbanisation will occur in poor or developing countries [9]. UNESCO predicts that by 2030, 4.9 billion people, approximately 60 % of the world’s population, will be urban dwellers [1]. The countries that are urbanising most rapidly are also among the least well prepared to satisfy their food needs, and many already depend precariously on food aid and imports [10].

The growing population, coupled with water scarcity in many parts of the world, would significantly affect availability and livelihoods of many urban poor residents in developing countries. Water scarcity will have significant impact on agriculture food production. Water for irrigation and food production constitutes one of the greatest pressures on freshwater resources accounting for over 70 % of global withdrawals [5]. UN-HABITAT estimates that in Africa and Asia, 85–90 % of all freshwater resources are used for agriculture [9] and, in particular, in the cities of the developing world, where almost all world population growth will occur and food demands will increase accordingly.

Ensuring food security and appropriate nutrition of the urban population, in particular the poorest households, has become a tremendous challenge in many cities in developing countries [4]. The population growth and urbanisation shifts in dietary habits have been noted and will increase food consumption in most regions of the world. It is estimated that by 2050, additional production of one billion tonnes of cereals and 200 million tonnes of meat will be needed to satisfy growing future food demand [3]. Producing 1 kg of cereal grains requires about 1 m<sup>3</sup>, or a thousand litres of water, of crop evapotranspiration, whilst 1 kg of meat requires much more water to produce depending on how much animal fodder grown under irrigated

conditions is given to the animals versus animals that graze on rainfed pastures [6–8].

Evidence from research across the globe demonstrates that urban agriculture and peri-urban agriculture play an important role in addressing rising food demands and delivering food products to the cities. However, this will require large amounts of additional water for irrigation, whilst scarce water supplies remain fixed; untreated or partially treated wastewater is being produced. Wastewater is increasingly being used for irrigation in agriculture, both in developing and industrialised countries, and research has shown that it is one way to bolster urban food supplies whilst also increasing the income of the poor.

Studies in the Southern Africa region [11–16] reported that urban and peri-urban agriculture contributes greatly to the food security of many urban residents. It enhances considerably the degree of self-sufficiency in cereal, fresh vegetable and small livestock production. Self-produced food provides nutritious food otherwise unaffordable and replaces purchased staples or supplements with more nutritious foodstuff. In addition, money saved by such production can be spent on non-produced foodstuff or other needs and generates principal income that can be reinvested in other urban businesses.

### 3 Urban Agriculture

Urban agriculture is described as activities commonly practised in community gardens (formal and informal), home gardens, institutional gardens, cultivation in cellars and barns (e.g. mushrooms, earthworms) [10, 17, 18]. Data from research indicates that intra-urban agriculture tends to be more small-scale and more subsistence oriented. Three main production systems in urban agriculture have been distinguished – (i) *specialised production systems* focusing on a single crop or animal such as rice, vegetables, fruit, fish and chicken; (ii) *mixed production systems*, which combine two activities (two main crops or mixed crop and animal); and (iii) *hybrid production systems*, which combine more than two main activities (crops and/or animals) [19].

Urban agriculture utilises urban resources such as land, labour, urban organic wastes, water and produces for urban citizens. Its success has been noted to be influenced by the urban conditions such as policies, competition for land, urban markets and prices and hence has an impact on the urban system (urban food security and poverty, urban ecology and health) [15, 18]. Though urban agriculture is practised as temporary use of vacant lands, it is a permanent feature of many cities in developing and developed countries and thus an important component for sustainable city development.

Urban agriculture has become part of the food security system in urban areas of most countries in Asia and Eastern and Southern Africa. It has expanded massively in the last 20 years in response to changes in the microeconomic environment characterised by poor economic performance resulting in increased poverty levels

in the urban areas [11, 20, 21]. In the past decades, local authorities and central governments have recognised urban agriculture as a legitimate land use in some countries. It is now generally recognised that urban and peri-urban agriculture contributes to household food security and also has a wide role in sustaining urban populations in terms of poverty alleviation and contribution to the urban economic activities, through processing and marketing of the produce [20–22]. Most governments and local authorities now support urban agriculture and are seeking ways in which to facilitate sustainable, safe and profitable production. In addition, urban agriculture is now an established strategy for sustaining livelihoods of urban populations, as it has been shown to directly provide food and indirectly generate household cash income through saving on food expenditure, employment and selling of surplus production. Significant population in many developing countries are active in urban agriculture. It is estimated that in Sub-Saharan Africa (SSA), 10 % or more are active (11 million people), whilst in Southeast Asia, seven million people are estimated to be engaged in intensive urban agriculture, producing perishable, high-value commodities. In Latin America, urban agriculture is mainly in horticulture, dairy and poultry, whilst in Eastern Europe, it is mainly practised on vegetables, fruit and small animals [23].

### ***3.1 Wastewater Use for Urban Agriculture***

As urbanisation continues, demand for freshwater is increased, yet most parts of the world are facing water scarcity. The use of urban wastewater for agriculture crop production is receiving renewed attention in most parts of the world due to this increasing scarcity of water. The use of wastewater for urban agriculture is increased with about 20 million ha of land under irrigation. The major challenge of wastewater use is public and environmental health concerns which may result in disease outbreaks such as cholera. On the other hand, the challenges are not insurmountable and hence can be managed.

Water scarcity has placed pressure on the ability of households to meet their basic needs as the intermittent supply of water has created a demand for other sources of water, such as wastewater for irrigation, which can either be expensive or dangerous to public health. As many countries are facing water scarcity as a result of dwindling supplies of fresh surface and groundwater, wastewater use and recycling assume a greater role than before to keep up with the increasing population growth and the demand for increased quality and additional quantities of food.

### ***3.2 Extent of Urban Wastewater Use for Urban Agriculture***

Urban agriculture irrigation with municipal wastewater is practised in many urban and peri-urban areas of developing countries. However, information regarding

wastewater generated, treated and used at country levels is limited. It has been reported that only 55 countries have data available on wastewater generation, treatment and use [24]. The quantity of wastewater produced worldwide in cities is rising steadily with urban growth. However, actual data on amount of wastewater produced is limited and is under-reported. It is estimated that, annually,  $10^9$  m<sup>3</sup>/year wastewater is generated within urban areas [25] and around 20 million ha (7 % of the total irrigated land) is under irrigation with untreated or partially treated wastewater [22]. It has further been reported that, on a global level, around 200 million farmers use treated, partially treated and untreated wastewater to irrigate their crops, including areas where irrigation water is heavily polluted [26].

It has been predicted that the use of untreated wastewater in urban agriculture will increase at approximately the same rate as the population growth in the cities of developing countries [22]. These trends are more visible in cities and towns in Africa and Asia, where population growth will almost treble from 414 million (current) to more than 1.2 billion by 2050, whilst the entire Asian population will grow from 1.9 billion to 3.3 billion in that same period [9, 27] This implies that more than half of the population of Africa and Asia will live in urban areas. This development will consequently create pressure on most municipalities and governments to provide adequate infrastructure for social services, an issue with which most African municipalities are struggling. Due to the difficulties in providing social services as well as creating income-generating opportunities, most of Africa's urban population will resort to self-help activities in a bid to satisfy their basic household needs, especially food [28].

Urban environmental management has become critical as urbanisation of developing nations continues on an upward trend. This urbanisation has introduced many challenges to urban planners and managers, including the need to ensure that basic human services are maintained in proportion to the population, such as water, sanitation and the management of wastewater. Poor management of industrial and domestic wastewater in many urban areas in most developing countries is a major problem, and this contributes to the contamination of locally available freshwater supplies with a degenerative effect on public health and the environment [29].

## **4 Wastewater for Urban Agriculture**

### ***4.1 Sources of Wastewater***

The wastewater used for agricultural irrigation comes from different sources and is of different qualities, ranging from raw to diluted, generated by various urban activities [30, 31]. The characteristics of wastewater discharges will vary from location to location depending upon the population and industrial sector served, land uses, groundwater levels and degree of separation between stormwater and sanitary wastes. Domestic wastewater includes typical wastes from the kitchen,

bathroom and laundry, as well as any other wastes that people may accidentally or intentionally pour down the drain. Sanitary wastewater consists of domestic wastewater as well as those discharged from commercial, institutional and similar facilities [32]. The range of flow usually varies from a minimum of about 20 % to a maximum of about 400 % of the average dry weather flow for small communities and about 200 % for larger communities. Industrial wastes will be as varied as the industries that generate the wastes. The quantities of stormwater that combines with the domestic wastewater will vary with the degree of separation that exists between storm sewers and sanitary sewers. Most new sewerage systems are separate, collect sanitary wastewater or stormwater, whereas older combined systems collect both sanitary wastewater and stormwater [33]. Wastewater types for urban agriculture use are categorised as follows [4]:

- (i) Direct use of untreated wastewater from a sewage outlet and directly disposed on land where it is used for cultivation.
- (ii) Direct use of treated wastewater occurs when wastewater has undergone treatment before it is used for agriculture or other irrigation or recycling purposes.
- (iii) Indirect use of treated or untreated urban wastewater occurs when receiving water bodies abstracted by farmers downstream for agriculture use. This occurs in most cities which lack a comprehensive sewage collection network and treatment.
- (iv) Planned use of wastewater is controlled use of wastewater either raw (i.e. untreated) or diluted/treated.

## ***4.2 Quality of Wastewater in Urban Environments***

Requirements for wastewater use can be applied for various beneficial purposes such as agricultural irrigation, industrial processes and groundwater recharge and even for potable water supply after extended treatment. To ensure sustainable and successful wastewater reuse applications, the following requirements must be fulfilled: the potential public health risk associated with wastewater use is evaluated and minimised, and the specific water reuse applications meet the water quality objectives. In order to meet the requirements, it is necessary to treat the wastewater prior to reuse applications and ensure an appropriate level of disinfection to control pathogens. Whilst a comprehensive overview of wastewater treatment options and public health protection is beyond the scope of this chapter, the following sections provide brief summaries on the basic quality of wastewater used in urban agriculture.

Chemically, wastewater is composed of organic and inorganic compounds as well as various gases. Organic components consist of carbohydrates, proteins, fats and greases, oils, synthetic pesticides and phenols. Inorganic components consist of heavy metals, nitrogen, phosphorous, chlorides and other toxic compounds. In domestic wastewater, the organic and inorganic portion is approximately 50 %,

respectively. Since wastewater contains a higher portion of dissolved solids than suspended, about 85–90 % of total inorganic component is dissolved, and about 55–60 % of total organic component is also dissolved [12, 33, 34].

Biologically, wastewater contains various microorganisms which include many pathogenic organisms, such as *Vibrio cholerae*, which generally originate from humans who are infected with disease or who are carriers of a particular disease [29].

Wastewater use poses health and environmental risks if no measures are put in place. Untreated wastewater generated from cities and industries potentially contains a wide range of different contaminants, such as pathogens, organic compounds, synthetic chemicals, nutrients, organic matter and heavy metals. The Guidelines for the Safe Use of Wastewater and Excreta in Agriculture and Aquaculture [29] set recommendations for crops to be consumed uncooked and crops to be cooked or used as feed, as well as for parks and localised irrigation. These Guidelines recommend minimised exposure to workers, crop handlers, field workers and consumers and set standards for treatment options to meet the guideline values.

### 4.3 Key Parameters in Wastewater

Nitrogen and phosphorus are essential to the growth of plants and, as such, are known as major nutrients [35, 36]. Plants and some microorganisms readily absorb nitrates and ammonia ions from the soil. A high concentration of nitrogen may stimulate excessive growth and cause lodging, delayed crop maturity and poor crop quality [36, 37]. However, most crops are not affected by nitrogen concentrations below 30 mg/l. There have been incidences where medium intensity irrigation with wastewater produced significantly higher yields than irrigation with freshwater supplemented with standard doses of nitrogen, phosphorous and potassium [16]. Plant uptake of nutrients accounts for up to 40 % of nitrates applied, depending on the crop type [38, 39].

Phosphorus is one of the essential plant nutrients and is frequently a limiting factor in vegetative productivity [40]. Applied phosphorous either is taken up by plants, is incorporated into organic phosphorous or becomes weakly or strongly absorbed onto aluminium, iron and calcium surfaces, depending on the pH [41]. Continuous long-term application of phosphorous at levels exceeding crop requirements increases the potential of phosphorous loss through run-off and drainage water [41] leading to the eutrophication of surface water bodies. Long-term application results in the top 30 cm of the soil becoming saturated with phosphorous due to absorption, greater bioactivity and accumulation of organic matter [41–43].

The level of trace elements in treated sewage effluents is determined by the chemical properties of the raw sewage from which these effluents were derived and the treatment method used. Secondary sewage treatment reduces the trace element



content through the settling of suspended solids by up to 70 %. Many sewage effluents are suitable for long-term irrigation with the threshold for trace elements based on the most sensitive crops [39]. Trace elements are taken up by plants and tend to accumulate in plant tissues at different rates, but plant properties differ greatly and the effect of soil conditions is often decisive [22]. Cadmium is considered a potentially serious health hazard because of its mobility in the food chain and its toxicity to plants and humans [44].

A number of factors affect metal availability in soils. Bio-availabilities of metals are those metals that are in soil solution in a form that can be readily taken up by plants [37]. High concentrations of cadmium, lead, iron, manganese, aluminium, copper and nickel pose a potential health hazard to humans and animals. Copper, zinc and nickel are phototoxic, and metals such as cadmium, mercury and lead are nonessential to the living being and have high toxic effects if they accumulate in the food web [39]. Lead and cadmium metals are known to be cumulative toxins and can affect animals, including human beings. In plants they are known to interfere with the metabolic processes thereby affecting plant growth and crop yields [38].

#### **4.4 Health Risks of Wastewater**

Health risks from wastewater usually manifest directly as outbreaks of food-, water- and vector-borne diseases (e.g. intestinal helminth infections or diarrhoeal diseases) and non-communicable diseases resulting from exposure to heavy metals. Other health effects are through contamination of drinking water sources, with nitrates or the production of toxic cyanobacteria.

Research has shown that health risks of concern are usually context specific, and in cases of developing nations, risks from microbiological contaminants receive most attention since populations are most affected by diarrhoeal diseases and helminth infections related to poor sanitation. In higher-income settings where microbiological risks are largely under control, chemical pollution and emerging pollutants are a larger public concern [29]. Health risk have been categorised as follows:

- (i) Contamination of crops with pathogenic organisms from untreated or partially treated wastewater or the unhygienic handling of the fresh products during transport, processing and marketing [29, 45]
- (ii) Contamination of crops and/or drinking water by heavy metals contained in wastewater
- (iii) Contamination of crops by heavy metals from contaminated soils, irrigated by untreated or partially treated wastewater

Table 1 shows health risks associated to wastewater irrigation which can result in several pathogens infecting humans from crop products.

**Table 1** Health risks associated with the use of wastewater for irrigation (Source [29])

Group exposed	Nematode infection	Bacteria/viruses	Protozoa
Consumers	Significant risk of <i>Ascaris</i> infection for both adults and children with untreated wastewater	Cholera, typhoid and shigellosis outbreaks reported from use of untreated wastewater; seropositive responses for <i>Helicobacter pylori</i> ; increase in nonspecific diarrhoea when water quality exceeds 104 thermotolerant coliforms/100 ml	Evidence of parasitic protozoa found on wastewater-irrigated vegetable surfaces, but no direct evidence of disease transmission
Farm workers and their families	Significant risk of <i>Ascaris</i> infection for both adults and children in contact with untreated wastewater; risk remains, especially for children, when wastewater treated to <1 nematode egg per litre; increased risk of hookworm infection in workers	Increased risk of diarrhoeal disease in young children with wastewater contact if water quality exceeds 104 thermotolerant coliforms/100 ml; elevated risk of <i>Salmonella</i> infection in children exposed to untreated wastewater; elevated seroresponse to norovirus in adults exposed to partially treated wastewater	Risk of <i>Giardia intestinalis</i> infection was insignificant for contact with both untreated and treated wastewater; increased risk of amoebiasis observed with contact with untreated wastewater
Nearby communities	<i>Ascaris</i> transmission not studied for sprinkler irrigation, but same as above for flood or furrow irrigation with heavy contact	Sprinkler irrigation with poor water quality (106–108 total coliforms/100 ml) and high aerosol exposure associated with increased rates of infection; use of partially treated water (104–105 thermotolerant coliforms/100 ml or less) in sprinkler irrigation is not associated with increased viral infection rates	No data on transmission of protozoan infections during sprinkler irrigation with wastewater

#### 4.5 Environmental Risk

Wastewater contains various types and levels of constituents, depending on the source from which it is generated and the level of its treatment. In most cases it contains organic chemicals, debris and solutes, pathogenic and non-pathogenic components and a wide range of range of elements that can either be beneficial or not, and these include essential plant nutrients. One of the major challenges of

wastewater disposal is the discharge of high levels of nitrogen and phosphorous into water bodies, resulting in eutrophication problems affecting the health and functioning of marine and freshwater ecosystems.

High concentrations of chemical constituents such as metals in wastewater-irrigated environments are an environmental challenge, and such metals and metalloids include cadmium, chromium, nickel, zinc, lead, arsenic, selenium, mercury, copper and manganese, among others. Salts and specific ions such as sodium, boron and chloride also pose challenges to the environment.

#### **4.6 Benefits of Wastewater Use**

Wastewater has been demonstrated to be a cheaper and more reliable water resource for agriculture in low-income dry areas [29]. Wastewater contains nitrogen and phosphorus which might result in higher yields compared to freshwater irrigation without additional fertiliser application. It was also demonstrated that the cost of using wastewater is cheaper than canal water irrigation, although wastewater farmers require more frequent and intensive labour inputs [22].

Benefits of using wastewater have been investigated in various parts of the world particularly in Asia, West Africa and Latin America. Studies by [45–47] demonstrated the potential of wastewater in the improvement of livelihoods and employment opportunities. The Faisalabad study [47] confirmed that wastewater irrigation offers benefits that can help many rural water-short areas in Pakistan and increase their agricultural productivity and profitability. Peri-urban farmers in Kumasi, Ghana, were reported to be generating revenue as high as US\$ 6 million (US\$ 500/ha/year) with profits of at least US\$ 4 million from irrigation of vegetables using wastewater [48]. Similar observations were made in India, City of Hyderabad, where an estimated US\$ 555 per year is generated by farmers from leafy vegetables. The United Nations development programme estimated that 800 million people are engaged in urban agriculture worldwide, with the majority in Asian cities. Thus urban agriculture is an important supply source in developing countries' urban food systems as well as a critical food security valve for poor urban households [10].

The situation in Pakistan demonstrates a widespread and pervasive practice of wastewater reuse by resource-limited people. In Pakistan, an estimated 25–35 million people in the Indus Basin live in areas with brackish groundwater and very low rainfall and thus depend on surface irrigation for all their water needs, and, hence, wastewater is an important resource for livelihoods [22]. It was also demonstrated that the cost of using wastewater was cheaper than canal water irrigation.

In India, the economic value of domestic wastewater has been estimated to be of high value contributing an estimated amount of essential elements of up to 500 tonnes nitrogen, 125 tonnes phosphate and 416 tonnes potassium per day and valued at 4.39 million rupees per day. The total annual value of nutrients is estimated to be 1,595 million rupees. In Bulawayo, Zimbabwe, wastewater is

estimated to contribute 92 kg/ha/year nitrogen, 108 kg/ha/year phosphate and 281 kg/ha/year potassium [49]. With proper management, this nutrient value can be transferred to crops and reduce the application of chemical fertilisers.

The potential contribution of products from urban agriculture using wastewater to the food security of poor households and communities are highlighted above. The short-term benefits of wastewater reuse in urban agriculture could be offset by the health and environmental implications. The main problem is the threat to public health, soil and water, if reuse is not done carefully. Potential benefits of wastewater use for urban agriculture can be categorised as follows:

**Household Level** The direct economic benefits include self-employment, income from products, sales of surpluses, savings on food and health expenditures, which could be used for school fees, and other household expenses [45].

**City Level** The positive effects have added value to the city (enhanced income or reduced costs) and contribution to the gross domestic product (GDP) and improved national food security system [49].

## 5 Research on Benefits of Wastewater Use to Livelihoods and Food Security

As highlighted in the topics above, many regions of the world, particularly in water-scarce urban and peri-urban areas, wastewater is being used for agricultural purposes. In some countries, agricultural wastewater use practices and guidelines follow national regulations or international guidelines and safety standards, but the reality is that in many developing countries, the use of wastewater is mostly unregulated. Furthermore, the lack of implementation of guidelines and safety standards could lead to health risks. As wastewater use is gaining momentum and recognition, the international community has recognised that the safe use of wastewater in agriculture is an important water resource that needs to be addressed, and efforts are being made in most countries to implement safe use guidelines and practices. UN-Water members and partners launched a global project with the aim to develop national capacities, skills and knowledge for the promotion and safe use of wastewater in agriculture.

In deriving the economic benefits of water, it should be noted that many researchers found it difficult to make estimates of the real economic value because of the informal nature of the practice and the resistance of some farmers to give precise figures. Using estimates based on the main crops and their market value, estimates were derived and are highlighted in some of the examples below:

- (a) Kessler [50] analysed different farming systems in four West African capitals which practised mixed vegetable farming with watering cans and/or with pumps and who cultivated short- and long-cycle vegetables such as lettuce,

cabbage, carrots and onions. He reported that the annual profit ranges from US \$ 20 to US\$ 700, depending on the management capacities and farm size.

- (b) A study in peri-urban of Ho Chi Minh City, Vietnam, on the profitability of peri-urban vegetable production systems (with rice and/or groundnut as additional crops) reported a net income between US\$ 500 and US\$ 1500/ha for most vegetable species [51].
- (c) In Nairobi, Kenya, urban agriculture represents the highest self-employment earnings in small-scale enterprises and the third highest earnings in all of Kenya [52]. Furthermore, studies in Nairobi estimate that when irrigated production continues throughout the year, average annual family income generated from wastewater-irrigated agriculture was US\$ 279 [48].
- (d) In Mexico, the gross annual water value of the wastewater used in the 140 ha of agricultural land in the area was estimated at US\$ 252 000 and the estimated gross annual value of the nutrient load to be US\$ 18 900 [33].
- (e) In Zimbabwe, estimated monetary income for each plot holder in Bulawayo, Cowdray Park, was reported as US\$ 20 per month from vegetables, US\$ 50 from sugar beans and US\$ 250 from green maize. The estimated annual income from each plot was calculated at US\$ 540 [53].
- (f) In Senegal, urban farmers in Dakar indicated that they earned US\$ 2234 annually [49].
- (g) In Haroonabad, Pakistan, wastewater farmers earn an estimated US\$ 300–600 more per year than non-wastewater farmers, and the majority of wastewater farmers were landless and leased land for agricultural production [54].
- (h) In Hyderabad, India, reported annual earnings per ha from a variety of crops grown with wastewater (paragrass, leafy vegetables) ranged from US\$ 830 ha/year to US\$ 2800 ha/year [30].

The above studies are just selected examples, and it should be noted that in many cities, intra- and peri-urban agriculture covers a substantial part of the urban demand for vegetables (especially fresh green vegetables). In addition to its contribution to food security, self-production of food reduces the monthly household expenditures on food, leaving more cash available for other basic household needs (health, housing, education and clothing).

Wastewater use for urban agriculture has been demonstrated to be one of the solutions in addressing issues of water scarcity. If supported from the policy-level and relevant institutions, the use of wastewater in agriculture offers great promise for environment and health protection as well as livelihood resilience. Its impact is greater in developing countries where untreated, inadequately treated or diluted wastewater is used for irrigation and wastewater irrigation is expected to increase in the foreseeable future.

## 6 Case Study: Bulawayo, Zimbabwe

In this section, we discuss our case study in Bulawayo, Zimbabwe. We evaluated water quality from treated domestic water effluent and determined heavy metal content in soils and crops under irrigation with treated domestic wastewater effluent.

### 6.1 Study Area

Our study site is in Luveve Gum Plantation area, in Bulawayo, Zimbabwe. Our goal was to determine the chemical and heavy metal content in soils and crops under irrigation with treated domestic wastewater effluent for the time period 2006–2010. The Luveve Gum Plantation farming area is located about 12 Km west of the Bulawayo City centre just after the Luveve high-density suburb. Wastewater effluent is derived from residential suburbs of Entumbane, Makokoba, Magwegwe, Lobengula, Calderly and Luveve. The effluent is mainly domestic with few home industries in the residential areas which include garages, welding and fabrication shops and home industries. Wastewater from the suburbs is treated through two systems, and the effluent is channelled to the Luveve Gum Plantation. The Magwegwe sewage plant uses the stabilisation pond system, whilst the Luveve uses the conventional trickling filter with a capacity of 4.0 ML/day and 3.5 ML/day, respectively.

Farmers use flood system to irrigate their fields and effluent flows in earth-lined canals (Figs. 2 and 3). Common crops grown include covo (*Brassica oleracea*)



**Fig. 2** Farmers working on vegetable plots irrigated with partially treated domestic wastewater in Bulawayo, Zimbabwe (Photo by the first author, 2008)



**Fig. 3** Wastewater disposed directly onto land in Bulawayo, Zimbabwe (Photo by the first author, 2008)

variety *acephala*), sugar beans and maize (*Zea mays*). The common seed variety used for *Zea mays* is the open-pollinated variety (OPV-SC403). Produce from the plots is both for sale and family consumption.

## 6.2 Methods

For effluent analysis, sampling sites were spatially selected on the farm. Two litre samples were collected as discrete samples at the five different sites into sample bottles which were soaked overnight in dilute hydrochloric acid. The analysis of effluent at the water quality laboratory was done following recommendations by Greenberg et al. [55]. The analysis of nutrients and two heavy metals (cadmium and lead) was done at the wet chemistry laboratory of Zimlab and the Geology Department and water quality laboratory of the Soil Science Department, University of Zimbabwe. The concentration of selected metals, cadmium and lead, in the effluent was determined using the atomic absorption spectrophotometer (PU 9100 manufactured by Philips).

Faecal and total coli form analysis was done within 6 h of the last sample collection using the ELE Paqualab Kit (manufactured by E L E International Ltd).

Composite samples of vegetables and soils were collected from the field at different sites. The samples (vegetables) were collected on plants adjacent to where soil samples were collected. A total of six vegetable sets were collected.

Vegetable tissue samples were collected in the zones around the soil sample point within a radius of 10 m from each point. For the control, three sites outside the farming area were selected, and composite samples were collected on each site for soil and vegetables. The analysis of metal accumulation in soils and vegetables was done following recommendations by Harold et al. [56], at the Government Analyst Laboratory.

### **6.3 Effluent Temperature**

Effluent temperature was measured during the study period, and a mean temperature value was  $22.4\text{ }^{\circ}\text{C} \pm 1.4$  with a minimum of  $20\text{ }^{\circ}\text{C}$  and a maximum of  $24\text{ }^{\circ}\text{C}$ . Effluent temperature has been shown to have some impact on desorption of nutrients such as phosphorus. Studies by Mamo et al. [57] demonstrated that desorption was higher at higher temperatures compared to lower temperatures. Similarly an average temperature of  $22.4\text{ }^{\circ}\text{C}$  measured could probably influence desorption and leaching of nutrients.

### **6.4 Effluent pH**

A pH of 6.5–8.4 is desirable for effluent quality for irrigation according to the FAO [58] and ZINWA [59] guidelines. The observed pH ranged from 6.89 to 8.6 with an average of  $7.9 \pm 0.4$  and was within the desirable range. According to the US EPA [60], a low pH effluent of less than 6.5 promotes leaching of most heavy metals, whereas a pH of greater than 11 destroys bacteria and whilst a neutral pH can temporarily inhibit movement of heavy metals through the soil. The average pH of 7.9 observed indicates that the wastewater is slightly alkaline. Alkalinity of wastewater has been demonstrated by Uwimana et al. [61] to affect mobility and uptake of heavy metals. The alkalinity of wastewater used in Bulawayo supports the findings of Uwimana et al. [61], and as such tests conducted on soils and plants in this study demonstrated that no significant levels of metals (cadmium and lead) were detected in the selected crops as the metals were immobilised.

### **6.5 Effluent Turbidity**

High level of turbidity was measured in this wastewater and suggests that the channel bringing the wastewater to the site contributed significantly as it picked up sediments in the unlined canals to the field. In addition, the high turbidity observed can be attributed to growth of phytoplankton which has access to the nitrates and phosphates in the wastewater. The wastewater provides favourable



conditions for the growth of phytoplankton as the temperature (22.4 °C) measured at the study site was ideal to support biochemical activities of aquatic species which is in agreement with observation by authors such as Alexander et al. [62] who reported a relation between temperature and turbidity. Turbidity in the effluent was composed of organic and inorganic constituents derived from the households and also from the earth canal which is not lined at the study site (farm). Higher turbidity levels pose higher health risk to people as organic particulates harbour microorganisms. High turbid conditions have been reported to increase the possibility of waterborne diseases because particulate matter harbours microorganisms and stimulates growth of bacteria, thereby posing some health risk to the effluent users [63].

## 6.6 Effluent Electrical Conductivity

Electrical conductivity (EC) is widely used to indicate the total ionised constituents of water. It is directly related to the sum of the cations (or anions), as determined chemically, and is closely correlated with the total dissolved salt (TDS) concentration. The variance in EC values measured over the study period was expected because the conditions where the wastewater originates differed from day to day as it was influenced by the residents' activities, such as saloons and backyard garages that contribute to the constituents of the wastewater. The FAO [57] recommends an electrical conductivity of 0–2000  $\mu\text{S}/\text{cm}$  for wastewater that can be safely used for irrigation, whilst wastewaters with EC values less than 1000  $\mu\text{S}/\text{cm}$  are desirable and are not expected to pose problems for irrigation use, unless the sodium adsorption ratio (SAR) of the wastewater is greater than four. In this study, SAR was found to be 3.2 and, therefore, is in line with recommendations from FAO that the wastewater is suitable for irrigation and is not expected to cause any problems to crops and the plants. Table 2 shows the guidelines for EC and TDS effluent discharge into surface waters.

## 6.7 Effluent Heavy Metal Level

Wastewater irrigation is known to contribute significantly to the heavy metal contents of soils [64, 65]. Long-term wastewater irrigation may lead to the

**Table 2** Guidelines for EC and TDS discharge into surface waters [59]

	Bands				
	Blue		Green	Yellow	Red
	Sensitive	Normal			
EC ( $\mu\text{S}/\text{cm}$ )	$\leq 200$	$\leq 1000$	$\leq 2000$	$\leq 3000$	$\leq 3500$
TDS (mg/l)	$\leq 100$	$\leq 500$	$\leq 1500$	$\leq 2000$	$\geq 3000$

accumulation of heavy metals in agricultural soils and plants. Sewage effluent contains a wide spectrum of other chemicals at low concentrations, but these are determined by the source of the wastewater such as industrial and domestic discharges [63]. In this study, the effluent cadmium level was 0.027 mg/l and that of lead was 0.45 mg/l. These values were all below the WHO-recommended standards [29]. The low levels of the metal concentration observed in the effluent was basically influenced by the source of the wastewater which was mainly domestic with backyard garages, fabricating workshops and saloons contributing to the metals in the wastewater.

Our study revealed that levels of the important parameters in agricultural irrigation, namely, nitrate, phosphates, potassium and sodium, were all within the required range for wastewater to be used for irrigation. Salinity is one of the major problems associated with wastewater-irrigated areas. In our study, the calculated SAR of 7.24 meq/l is within the set guidelines, and hence it is expected to pose low hazards according to the FAO. Therefore, the wastewater can be used for irrigation as little or limited salt is expected to accumulate in the soil and hence no significant impact on the soil structure.

A mean concentration of lead in the effluent was found to be 0.45 mg/l which is within the acceptable concentration for agricultural use [29]. A mean effluent concentration of cadmium was 0.027 mg/l. The observed concentration permits Zimbabwe's short-term application on the land but is not suitable for the long-term application whose limit is 0.01 mg/l. The long-term application with levels higher than the recommended value poses risk to both animals and plants as build-up of metals in the environment will be propagated.

## **6.8 Effluent Faecal Coliform**

The mean faecal coliform 5836 cfu/100 ml and total coliform 7291 cfu/100 ml that were observed surpassed both the recommended WHO and national standards for irrigation. Recommended microbiological quality guidelines for wastewater use in agriculture should not be more than 1000 cfu/100 ml particularly for irrigation of crops likely to be eaten uncooked, sports fields and public [29]. These observations suggest that the wastewater could be a source of bacterial infections especially to the farmers, and therefore proper handling will be required.

## **6.9 Conclusions from Case Study**

Accordingly, the assessed physical and chemical parameters are in compliance with existing local and international guidelines, and thus the effluent is suitable for use in irrigation on conditions that it is applied and managed properly to ensure that the environment and public health issues are protected.

Overall the physical and chemical parameters assessed in this study, which are of agricultural importance, were all within acceptable ranges of the local and WHO guidelines for wastewater use for agriculture irrigation. However the mean faecal coliform 5836 cfu/100 ml and total coliform 7291 cfu /100 ml that were observed surpass both the recommended WHO and national standards for irrigation. Thus, there is a need for improvement of wastewater treatment systems as well as efficient monitoring of the effluent. In addition, health precautions have to be taken seriously to safeguard the farmers and consumers of products from these plots.

The results of this study, to some extent, demonstrated that wastewater application influenced the drop in soil pH by 0.24–0.27 units in comparison to the wastewater-irrigated soil and the control soil, respectively. This observation is in conformity with findings by Nguyen et al. [66] and Khan et al. [67] with similar results where soil pH was reduced by 0.1–0.2 units. Other research by Vaseghi et al. [68] and Nguyen et al. [66] also demonstrated this phenomenon which they attributed to the decomposition of organic matter and production of organic acid in soils irrigated with wastewater that aided in reducing soil pH.

This study also revealed that irrigating with wastewater contributed to a numerical increase of cadmium and lead levels in the soil as compared to the control sites though not statistically significant. This is in agreement with findings of Mapanda et al. [64], Khan et al. [67] and Rahimi and Nejatkhani [70] who observed an increase of metals in soils. In relation to levels of the soil heavy metal concentration, the pollution index (PI) for the cadmium (1.4) and lead (1.7) was observed to be low as compared to studies by Myung Chae Jung [65]. The low PI levels are also a factor that has contributed to the low uptake of the heavy metals by maize and bean and chomolia. These findings are in conformity with past studies that have observed that heavy metal uptake depends on plant species and by soil to plant transfer factors of the metals [69, 74, 71]. In most of the studies carried out by other researchers, the concentrations of heavy metals was observed to be higher in crops irrigated by wastewater and as compared to other different waters [72, 75]. In our study, though the wastewater irrigation slightly increased the levels of cadmium and lead in the soils, this did not have a major effect on the uptake of these metals by crops (maize, chomolia and beans), as no significant metals were detected in wastewater-irrigated crops. In most of the studies carried out by other researchers, the concentrations of heavy metals was observed to be higher in crops irrigated by wastewater and as compared to other different waters [72]. This study presents a different scenario in which no significant levels of cadmium and lead were observed in the vegetable samples analysed which is contrary to some other findings.

It could be concluded that cadmium levels in irrigated soils and control soils showed no significant differences but had strong correlation with soil pH. The study also showed that lead concentration in the irrigated soils was higher than in controlled soils and this difference was found to be statistically different whilst no difference was found within the soil profiles. In addition, lead concentration in soil had strong association with soil pH; hence, its availability and uptake was affected by soil pH. The study also found no detectable levels of lead and cadmium in the three crops (chomolia, maize and sugar beans) analysed. It was also established that application of wastewater did not affect the soil texture content as it remained constant overtime.

Assessment of the soil texture in this study revealed that the use of domestic wastewater for irrigation did not change its texture as it remained sandy loam for the study period; thus no significant effect on a sandy loam soil was observed.

## **7 Sustaining Wastewater Use for Urban Agriculture: Discussion**

The use of wastewater sustains livelihood activities in urban and peri-urban areas through various ways such as having year-round availability for crop production and hence allows multiple cultivation cycles resulting in increased earnings from wastewater agriculture and improves poor farmers' livelihoods. Sustaining wastewater use requires that management strategies are put in place that include policies (enabling environment), research and stakeholders participation among others.

The research summarised above demonstrate that urban wastewater irrigation has a positive effect on the financial capital of the urban farmers. However, wastewater irrigation potentially causes health and environmental risks that may weaken socio-economic status of users. As the momentum to ensure that wastewater is safe increases, policymakers must safeguard the wider public interest, through adapting policies and strategies that promote integrated water resource management.

For wastewater use in agriculture to become a substitute for scarce freshwater resources in many developing countries and where its use is often unplanned, the policy implications are complex. In this respect many municipalities and local authorities are increasingly faced with the reality of farmers using poor-quality water for agriculture, and turning a blind eye is not an option. As such wastewater use can be managed within the context of limited infrastructure and resources and therefore minimise the risk as evidenced in some cases. Management strategies for managing wastewater use has been developed and piloted, and field-based experiments show that the following are ways that can be adopted and incorporated for sustainable use. Several opportunities for improving wastewater management exist, and these are elaborated in Fig. 4.

### ***7.1 Policy and Institutional Settings***

Wastewater use has diverse impacts on the environment and public health as well as food security. Proper wastewater management requires collaboration and dialogue between partners and stakeholders involved in wastewater issues; these include farmers, public health officials, municipal planners and developers, research institutions, consumers and the private sector. To address safe use of wastewater in agriculture, appropriate policies, legislation and institutional frameworks and

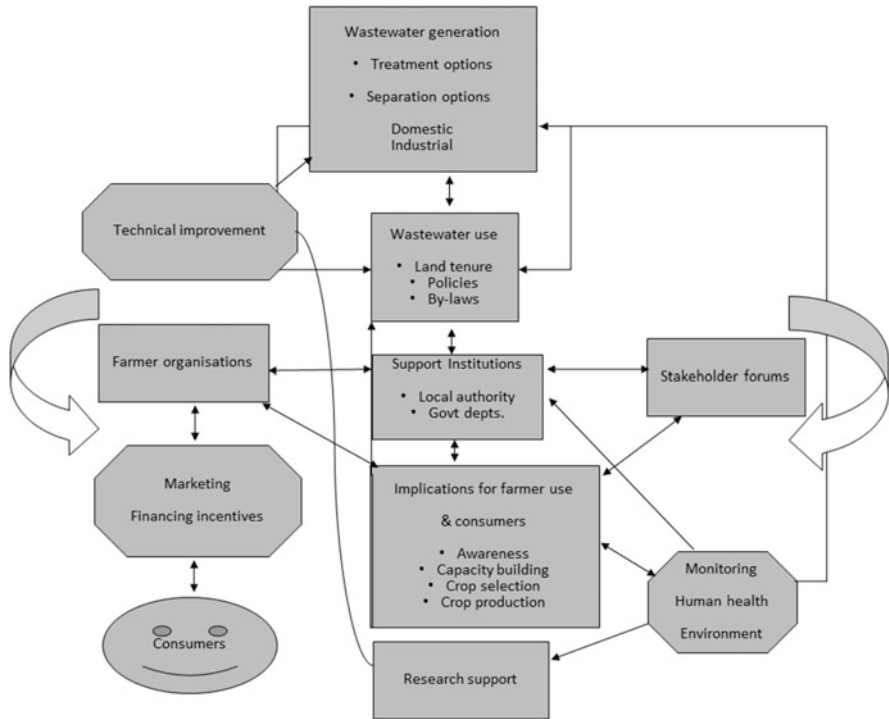


Fig. 4 Management options for sustainable wastewater use (Adapted from Makoni [53])

regulations at national and local levels need to be in place which will bring these actors together.

### 7.2 Stakeholder Forum and Participation

Given the multi-sectorial nature of wastewater irrigation projects, the varying interests and responsibilities of stakeholders must be considered and reconciled if the practice is to succeed. There are several stakeholders, and these range from council departments to central government ministries, NGOs, consumers, private sector and education and research institutions as highlighted above. Some of these stakeholders have a direct stake, whilst others have an indirect involvement. Local authorities play a crucial role in ensuring that key aspects of wastewater use, including accessing land, water, other resources and the regulatory environment, are facilitated. The NGOs will play a major part in making some of the resources available and enable capacity building, the associations play a part in lobbying and the private sector will be critical in ensuring market availability and making inputs available. Urban farmers themselves are major stakeholders as they will be directly

affected by the actions of the other stakeholders, hence the need for forums that addresses the interests of various stakeholder. If forums are put into place, numerous benefits of stakeholder participation in integrated wastewater irrigation projects would be realised. These include improving public acceptance of decisions, improving the quality of alternatives because of the wider range of expertise available, reducing the risk that opposition from disaffected groups will delay implementation of decisions and increasing the likelihood of compliance with agreements reached during negotiations.

Three key issues that need attention when considering stakeholder participation are outlined below. Firstly, stakeholder roles and responsibilities must be clarified; an important lesson from the long and successful experiences of Ghana, India, China and Israel with wastewater irrigation is that a clear separation of responsibilities between the urban, rural and other sectors regarding the treatment and application of wastewater is required. For example, municipalities (as the producer of polluting wastewater) are responsible for basic treatment costs, whereas farmers run the farms. Secondly, involving farmers and consumers in health protection measures is also important. The active participation of farmers and consumers is of particular importance to the success of wastewater irrigation projects. Farmers need to be educated on safe irrigation and postharvest practices. Consumers need to be informed about the safe handling and preparation of food crops irrigated with wastewater, such as training in safer production and food handling practices, which could accelerate risk reduction significantly. Thirdly, there is a need to disseminate information on appropriate policies and regulations that govern the use of wastewater at local levels. Information will be very vital as this will influence and promote safe irrigation methods, crop selection and postharvest management.

### ***7.3 Capacity Building and Outreach***

Several opportunities exist for improving wastewater use by farmers as they engage in their activities, as well as a need for improving our understanding on issues related to adopting approaches for wastewater use. Research information will be important as this will inform all the relevant stakeholders on the current status of their activities and where adjustment can be made or where change can be done. This can be useful to farmers and the institutions, if, for example, information on level of nutrients or heavy metals in wastewater is given. Farmers must be provided with specific guidelines to support their production and to be able to access markets. Moreover, proper dissemination and education campaigns must be designed to facilitate the adoption of such guidelines by farmers. This will enable the farmers to change their cropping patterns.

## **7.4 Marketing**

Various urban agriculture projects in many cities revolve around several concepts. Some of them are social projects, whilst others are trying to be economic ventures. The practices display a mixture of both economic and social aspects. Those that started as social projects have slowly turned to economic production – most of the vegetables produced are sold to nearby markets. However, the problem of marketing arises when production increases because most of the farmers are producing the same type of produce, e.g. leafy vegetables, crops, etc. Exploring opportunities for processing the produce from the urban farmers is needed because no thorough market research to inform the production patterns has been conducted. Currently, farmers are producing only what they know best to produce [29]. Monoculture also has a negative impact on the quality of vegetables produced. Therefore a marketing research needs to be conducted in order to inform the farmer.

Secondly, the farmers are not organised into cohesive groups. As a result they do not take advantage of group organisation to increase their bargaining power in buying inputs or trying to access other services. Thus formation of farmer groups becomes very vital to improve their incomes.

Thirdly, there is no value addition to the produce as they market it straight from the field. Farmers are aware that they could do value additions, but lack of knowledge and technology inhibits them. Capacity development in these areas also needs to be strengthened, and this will include the postharvest processing.

## **7.5 Creation of Enabling Environment**

Recognition of the potential uses of wastewater by many governments and even municipalities is a challenge. Such use has been limited or even prohibited, and most areas have no policies or laws to support such activities, so they remain informal and illegal. Municipal authorities are key in ensuring the creation of a conducive environment for urban agriculture using wastewater, by setting up a multi-actor city working group or similar platform on urban agriculture that coordinates the process of interactive formulation of policies and the planning and implementation of action programmes by the various actors.

Apart from illegality, the issue of land tenure for farmers is a key ingredient to successful management of wastewater. A legally binding agreement (e.g. lease) would give the necessary assurance and protect the farmers' rights, although this may create substantial increases in workload for local authorities involved in giving leases to many farmers who own very small pieces of land. These leases can also bring with them the issue of a rental fee which some of the farmers might not be willing to pay. A part of sustainability includes encouraging farmers to form associations, which can then get leases from the local authorities on behalf of members. This also provides a platform for urban agriculture to be considered as

a land use and thus can be provided for in city development plans. The key issue for success is stakeholder participation and action planning at all the stages.

The issue of access to land and management has been demonstrated in several cities, such as Nairobi and Accra, which have created municipal agricultural department. In Villa María del Triunfo, Lima, Peru, a subdepartment was created under the Department of Economic Development whilst, at the same time, urban agriculture was included as a priority area in the Concerted Economic Development Plan (2001–2010). Whilst in Cape Town, South Africa, an interdepartmental working group was established in 2002 to coordinate the urban agriculture activities of various municipal and provincial departments and facilitated integrated policy development [73].

## 8 Conclusions

The benefits of wastewater use for agriculture are clearly manifested from a number of studies, which demonstrate the impact on productivity, income and livelihoods for poor households. Variations have been observed by researchers on the differential impacts and profitability of the practice. In general it has been demonstrated to be profitable, particularly when producing products that are in great demand such as perishable products (green leafy vegetables, milk, mushroom, flowers and ornamental plants).

The literature reveals various approaches to the management of wastewater use though data has not been systematic and comprehensive. Available literature indicates that the practice is sustainable if it maintains its dynamism and flexibility, adapting to changing urban conditions and demands.

The urbanisation processes have lead increasing pressure on municipalities to manage the growing demand for water supply to produce food. This challenge has demanded alternative strategies towards improving livelihoods through appropriate policies and laws. To date an increasing number of municipalities have recognised the potential of wastewater use for urban agriculture as an avenue for realising social development and the alleviation of poverty. In this regard they have initiated policy formulation, action planning that involves multiple stakeholders in its design and implementation.

Future research needs include further research on the interaction of heavy metals and their uptake in the irrigated soils particularly in different geological zones. Such research would help improve understanding of metal uptake and their accumulation as influenced by the climatic conditions. In addition to the metal uptake and accumulation, there is a need to carry out a more detailed epidemiological study on the impact of consuming products from wastewater-irrigated farms.



## References

1. UNESCO (2006) *Water a shared responsibility*. The United Nations world water development report 2, New York, p 600
2. World Water Council (2009) 5th World water forum secretariat final report, Istanbul. <http://www.worldwatercouncil.org>
3. World Water Assessment Programme (WWAP) (2012) The United Nations world water development report 4: managing water under uncertainty and risk. Paris, UNESCO. <http://unesdoc.unesco.org/>
4. UN-Water (2013) Proceedings of the UN-Water project on the safe use of wastewater in agriculture. In: Jens Liebe J, Ardakanian R (eds). Coordinated by the UN-Water Decade Programme on Capacity Development (UNW-DPC), Bonn
5. FAO (2010) The wealth of waste: the economics of wastewater use in agriculture. FAO water reports, no. 35, Rome. [www.fao.org/docrep/](http://www.fao.org/docrep/)
6. Rijsberman FR (2002) Troubled waters, water troubles: overcoming an important constraint to food security. In: IFPRI (ed) Sustainable food security for all by 2020: proceedings of an international conference, Bonn, IFPRI, Washington, DC, 4–6 Sept 2001, pp 141–144
7. Rijsberman FR (2004) Sanitation and access to clean water. In: Lomborg D (ed) Global crises, global solutions. Cambridge University Press, Cambridge, pp 498–540
8. Rijsberman FR (2002) World water supplies: are they adequate? Paper presented at the 3rd rosenberg international forum on water policy, Canberra, 7–11 Oct 2002
9. United Nations Human Settlements Programme (UN-HABITAT) (2008) State of the world's cities 2010/2011. Bridging the urban divide, London, Earthscan. <http://www.unhabitat.org/>
10. Mougeot LJA (2000) Urban agriculture: definition, presence, potentials and risks. In: Bakker N, Dubbeling M, Guendel S, Sabel-Koschella U, de Zeeuw H (eds) Growing cities, growing food, urban agriculture on the policy agenda. DSE, Feldafing, pp 1–42
11. Bakker N, Dubbeling M, Guendel S, Sabel-Koschella U, de Zeeuw H (eds) (2000) Growing cities, growing food: urban agriculture on the policy agenda. Food and Agriculture Development Centre, Feldafing
12. Mara D, Cairncross S (1989) Guidelines for the safe use of wastewater and excreta in agriculture and aquaculture, measures for public health protection. WHO, Geneva in Collaboration with the United Nations Environment Programme
13. Mbiba B (1995) Urban agriculture in Zimbabwe: implication for urban management and poverty. Avebury, Aldershot/Brookfield
14. Mbiba B (2000) Urban agriculture in Harare: between suspicion and repression. In: Bakker N, Dubbeling M, Gödel S, Sabel-Koschella U, de Zeeuw H (eds) Growing cities, growing food. Urban agriculture on the policy agenda. A reader on urban agriculture. Deutsche Stiftung für Internationale Entwicklung, Feldafing, pp 285–302
15. Mougeot LJA (1994) Urban food production: evolution, official support and significance. Cities feeding people, report 8. Ottawa, IDRC
16. Nugent R (2000) The impact of urban agriculture on the household and local economies. In: Bakker N, Dubbeling M, Guendel S, Sabel-Koschella U, de Zeeuw H (eds) Growing cities, growing food, urban agriculture on the policy agenda. DSE, Feldafing, pp 67–97, Germany
17. de Zeeuw H, Guendel S, Waibel H (2000) The integration of agriculture in urban policies. In: Bakker N, Dubbeling M, Guendel S, Sabel-Koschella U, de Zeeuw H (eds) Growing cities, growing food, urban agriculture on the policy agenda. DSE, Feldafing, pp 161–182
18. Mougeot LJA (1999) For self-reliant cities: urban food production in a globalizing South. In: Koc M, MacRae R, Mougeot LJA, Welsh J (eds) For hunger-proof cities: sustainable urban food systems. IDRC, Ottawa, pp 11–25
19. Vagneron I, Pagès J, Moustier P (2003) Economic appraisal of profitability and sustainability of peri-urban agriculture in Bangkok. FAO/CIRAD, Rome
20. IDRC (2003) Guidelines for municipal policy making on urban agriculture: processing and marketing urban agriculture products. March edition no. 1. <http://www.ruaf.org/>

21. Obuobie E, Keraita B, Danso G, Amoah P, Cofie OO, Raschid-Sally L, Drechsel P (2006) Irrigated urban vegetable production in Ghana: characteristics, benefits and risks. IWMI-RUAF-CPWF, Accra, Ghana: IWMI, p 150
22. Scott CA, Faruqui NI, Raschid-Sally L (eds) (2004) Wastewater use in irrigated agriculture: management challenges in developing countries. CABI Publishing, Wallingford, p 208
23. FAO (2001) Crops and drops: making the best use of water for agriculture. Food and Agriculture Organization of the United Nations, Rome, pp 1–22
24. Sato T, Qadir M, Yamamoto S, Endo T, Zahoor A (2013) Global, regional, and country level need for data on wastewater generation, treatment, and use. *Agric Water Manage* 130:1–13
25. FAO-Aquastat (2008) Proportion of total water withdrawal withdrawn for agriculture. <http://www.fao.org/nr/water/aquastat/globalmaps/>
26. Raschid-Sally L, Jayakody P (2008) Drivers and characteristics of wastewater agriculture in developing countries: results from a global assessment. International Water Management Institute Research report 127, Colombo, Sri Lanka, p 35
27. United Nations (2006) World urbanization prospects: the 2005 revision. Department of Economic and Social Affairs/Population Division (UNDESA), New York, p 210
28. Argenti O (2000) Food for the cities. Urban food supply and distribution policies to reduce food insecurity. A briefing guide for mayors, city executives and urban planners of cities in developing countries and countries in transition, Food into cities collection, DT/43-00E. FAO, Rome, p 13
29. World Health Organisation (WHO) (2006) Guidelines for the safe use of wastewater, excreta and greywater, Geneva, vol 2, p 13. [http://www.who.int/water\\_sanitation\\_health/wastewater/](http://www.who.int/water_sanitation_health/wastewater/)
30. Buechler S, Gayathri Devi M, Raschid-Sally L (2002) Livelihoods and wastewater irrigated agriculture along the Musi River in Hyderabad city, Andhra Pradesh, India. *Urban Agric Mag* 8:14–17
31. Buechler S (2004) A sustainable livelihoods approach for action research on wastewater use in agriculture. In: Scott C, Faruqui NI, Raschid-Sally L (eds) Wastewater use in irrigated agriculture: confronting the livelihood and environmental realities. Commonwealth Agricultural Bureau International, Orient-Longman, and International Development Research Centre, Ottawa, pp 25–40
32. Rose DG (1999) Community based technologies for domestic wastewater treatment and reuse: options for urban agriculture. Report 27, CFP report series. International Development Research Center Canada (IDRC), Ottawa
33. The Green Lane (2002) [www.atl.ec.gc.ca/epb/issues/](http://www.atl.ec.gc.ca/epb/issues/)
34. Ellis TG (2004) Chemistry of wastewater. Environmental and ecological chemistry, vol II, EOLSS. <http://www.eolss.net/sample-chapters/c06/e6-13-04-05.pdf>
35. Metcalf and Eddy, Inc (1991) Wastewater engineering. Treatment, disposal and reuse, 3rd edn. Tata McGraw Hill Publishing Company Limited, New Delhi, p 133
36. Havens K, Frazer T (2012) Rethinking the role of nitrogen and phosphorus in the eutrophication of aquatic ecosystems. Institute of food and agricultural sciences, University of Florida. SGE190, pp 1–3. <http://edis.ifas.ufl.edu>
37. Amos A (2003) Impact of land disposal of sewage sludge and effluent on groundwater at Crowborough farm, Zimbabwe. Unpublished MSc thesis, Civil Engineering, University of Zimbabwe
38. Madyiwa S, Chimbari MJ, Schutte CF, Nyamangara J (2003) Greenhouse studies on the phyto-extraction capacity of *Cynodon dactylon* for lead and cadmium under irrigation with treated wastewater. *Phys Chem Earth* 28:859–867
39. Pescod MB (1992) Wastewater treatment and use in agriculture. FAO of the United States, Rome, FAO irrigation drainage paper 47
40. Kermani M, Bina B, Movahedian H, Amin MM, Nikaen M (2009) Biological phosphorus and nitrogen removal from wastewater using moving bed biofilm process. *Iran J Biotechnol* 7 (1):19–27
41. Veenstra IS, Polprasert C (2000) Sustainable wastewater treatment 1: natural treatment systems. (Lecture notes), IHE Delft, The Netherlands

42. Masona C, Mapfai L, Mapurazi S, Makanda R (2011) Assessment of heavy metal accumulation in wastewater irrigated soil and uptake by maize plants (*Zea mays L*) at Firlle Farm in Harare. *J Sustain Dev* 4(6):132
43. Rana L, Dhankhar R, Chhikara S (2010) Soil characteristics affected by long term application of Sewage wastewater. *Intl J Environ Res* 4(3):513–518
44. US Environmental Protection Agency (1983) Process design manual. Land application of municipal sludge. EPA-625/1-83-016, Office of research and development, Washington, DC
45. Drechsel P, Blumenthal UJ, Keraita B (2002) Balancing health and livelihoods: adjusting wastewater irrigation guidelines for resource poor countries. *Urban Agric Mag* 8:7–9
46. Ensink J, Simmons RW, van der Hoek W (2004) Wastewater use in Pakistan: the case studies of Haroonabad and Faisalabad. In: Faruqi NI, Raschid-Sally L (eds) *Wastewater use in irrigated agriculture: confronting the livelihood and environmental realities*. Commonwealth Agricultural Bureau International, Orient-Longman, and International Development Research Centre, Ottawa, pp 91–99
47. Ensink J, van der Hoek W, Matsuno Y, Munir S, Aslam R (2002) Use of untreated wastewater in Peri-urban agriculture in Pakistan: risks and opportunities. Research report 64. International Water Management Institute, Colombo
48. Cornish A, Lawrence P (2001) Informal irrigation in peri-urban areas. A summary of findings and recommendations. KAR project R7132. Report OD 144. Department for International Development (DFID), London
49. Fleury A, Ba A (2005) Multi-functionality and sustainability of urban agriculture. *Urban Agriculture Magazine*, no.15, Dec 2005. Multiple functions of urban agriculture. Leusden, RUAF
50. Kessler A (2002) Farming systems in urban agriculture in four West Africa cities, with special focus on its profitability, wastewater use and added malaria risk. Consultancy report submitted to FAO Ghana office via international water management institute, Ghana
51. Jansen HGP, Midmore DJ, Binh PT, Valasayya S, Tru CC (1995) Peri-urban vegetable production in Ho Chi Minh City, Vietnam. Working paper, AVRDC
52. House W, Ikiara G, McCormick D (1993) Urban self-employment in Kenya: panacea or viable strategy? *World Dev* 21(7):1205–1223
53. Makoni FS (2014) Characterisation of treated domestic wastewater and its potential use for small scale urban agriculture in Bulawayo: balancing health and environmental needs. PhD thesis University of the Free State
54. Ensink JHJ, Mahmood T, van der Hoek W, Raschid-Sally L, Amerasinghe FP (2004) A nation-wide assessment of wastewater use in Pakistan: an obscure activity or a vitally important one? *Water Policy* 6:1–10
55. Greenberg AE, Clesceri LS, Eaton AD (1992) Standard method for the examination of water and wastewater, 18th edn. American Public Health Association, Washington, DC, p 541
56. Harold E, Kirk RS, Sawyer R (1981) Pearson's chemical analysis of foods, 8th edn. Churchill Livingstone, Minnesota, p 591
57. Mamo M, Gupta SC, Rosen CJ, Singh UB (2005) Phosphorus leaching at cold temperatures as affected by wastewater application and soil phosphorus levels. *J Environ Qual* 34 (4):1243–1250
58. FAO (1985) Water quality for agriculture. In: Ayers RS, Westcot DW (eds) *Irrigation and drainage paper 29 rev. 1*. FAO, Rome, p 174
59. ZINWA (2000) Operational guidelines for the control of water pollution in Zimbabwe. Zimbabwe National Water Authority (ZINWA), Harare
60. USEPA (2002) Public health risk assessment for human exposure to chemicals. EPA/540/R/99/005 Washington, DC. <http://www2.epa.gov/sites/production/files/2015-09/documents/>
61. Uwimana A, Nhapi I, Wali UG, Hoko Z, Kashaigili J (2010) Sludge characterization at Kadahokwa water treatment plant, Rwanda. *Water Sci Technol* 10:847–858

62. Alexander PD, Aloway BJ, Dourado AM (2006) Genotype variations in the accumulation of Cd, Cu, Pb and Zn exhibited by six commonly grown vegetables. *Environ Pollut J* 144 (3):736–745. doi:10.1016/j.envpol.2006.03.001
63. FAO (2010) Wealth of waste: the economics of wastewater use in agriculture. FAO water report no. 35, Food and Agriculture Organisation (FAO), Rome
64. Mapanda F, Mangwayana EN, Nyamangara J, Gillera KE (2005) The effect of long-term irrigation using wastewater on heavy metal contents of soils under vegetables in Harare, Zimbabwe. *Agric Ecosys Environ* 107:151–165
65. Myung CJ (2008) Heavy metal concentrations in soils and factors affecting metal uptake by plants in the vicinity of a Korean Cu-W Mine. *Sensors* 8:2413–2423
66. Nguyen MK, Pham TT, Nguyen CV, Ingrid O (2008) Effects of using wastewater as nutrient sources on soil chemical properties in peri-urban agricultural systems. *VNU J Earth Sci* 24:87–95
67. Khan MJ, Jan MT, Farhatullah-Khan NU, Arif M, Perveen S, Alam S, Jan AU (2011) The effect of using waste water for tomato. *Pak J Bot* 43(2):1033–1044
68. Vaseghi S, Afyuni M, Shariatmadari H, Mobli M (2005) Effect of sewage sludge on some nutrients concentration and soil chemical properties. *J Isfahan Water Wastewater* 53:15–19 (in Persian)
69. Khan MJ, Jones DL (2008) Evaluation of chemical and organic immobilization treatments for reducing phytoavailability of heavy metals in copper mines tailings. *J Plant Nutr Soil Sci* 171:908–916
70. Rahimi B, Nejatkhah MP (2010) Availability, accumulation and elimination of cadmium by *artemia urmiana* in different salinities. *J Biol Environ Sci* 4(12):149–157
71. Rattan RK, Datta SP, Chhonkar PK, Suribabu K, Singh AK (2005) Long-term impact of irrigation with sewage effluents on heavy metal content in soils, crops and groundwater—a case study. *Agric Ecosys Environ* 109:310–322
72. Gyampo A, Ntiforo A, Kumi M (2012) Assessment of heavy metals in wastewater irrigated lettuce in Ghana: the case of Tamale municipality. *J Sustain Dev* 5:93–102
73. van Veenhuizen R (2006) Cities farming for the future: urban agriculture for green and productive cities. International Development Research Centre, Ottawa, <http://www.idrc.ca/EN/Resources/Publications/openebooks/216-3/index.html>
74. Nhapi I (2002) Wastewater reuse and sustainable sanitation. Wastewater treatment WREM lecture notes. Department of Civil Engineering, University of Zimbabwe, Harare
75. Chen ZS, Lee GJ, Liu JC (2000) The effects of chemical remediation treatments on the extractability and speciation of cadmium and lead in contaminated soils. *Chemosphere* 41:235–242

# Urban Water Management Challenges in Developing Countries: The Middle East and North Africa (MENA)

Magdy M. Abou Rayan and Berge Djebedjian

## Contents

1	Introduction .....	297
2	Water Resources and Urbanization .....	298
2.1	Urbanization and Water Cycle .....	298
2.2	Urbanization and Water Consumption .....	300
2.3	Challenges Facing Urban Water Management .....	300
2.4	The Climate Change Challenge .....	303
2.5	Response Options to Climate Change .....	306
3	Integrated Water Resources Management .....	306
3.1	Integrated Urban Water Management Doctrine (IUWM) .....	307
3.2	Water Resource Information System (WRIS) .....	308
3.3	Elements of Integrated Water Resources Management .....	309
3.4	Ecosystem Services .....	310
3.5	Policy Responses .....	310
3.6	Economic Costs and Benefits .....	311
3.7	The Role of the International Organizations .....	311
3.8	Privatization of Water .....	312
4	A Framework for Integrated Urban Water Management .....	313
4.1	Components of the Decision Support System (DSS) .....	313
4.2	Integrated Urban Water Management .....	315
4.3	Creating an Enabling Environment for IUWM .....	316
4.4	Roles for Central Governments .....	316
4.5	Roles for Local Governments .....	317
4.6	Private Sector Involvement .....	317
4.7	Business Opportunities Along the Entire Value Chain .....	317
4.8	“Urban” and “Basin” Management .....	318
4.9	Stakeholder Participation .....	318
4.10	Fostering a New Culture of Urban Water Management .....	319
4.11	Game-Changing Technologies and Approaches .....	319
4.12	Financing Potable Water Projects: Case Study in Egypt .....	320
5	Conclusions .....	322
5.1	Recommendations .....	323
	References .....	324

---

M.M. Abou Rayan (✉) • B. Djebedjian  
Water Research and Industrial Projects Center, Mansoura University, El-Mansoura, Egypt  
e-mail: [magdy.abourayan@gmail.com](mailto:magdy.abourayan@gmail.com)

**Abstract** Accelerated growing population and migration to urban areas in developing countries have resulted in a vital need for the establishment of protected source water and modern, well-maintained drinking-water treatment plants to disseminate potable water to residents. While the challenge in the developed world is mainly to prevent existing infrastructure from decay and to initiate a transition from the disposal-oriented regimes toward more sustainable approaches with a focus on reuse options, the situation is more complex in developing countries. Developing countries suffer from economic problems and are often struggling with insufficient infrastructure and low water supply and sanitation coverage, particularly in rapidly growing urban slum settlements, with significant consequences, especially regarding public health. In this chapter, we discuss the urban water cycle and water consumption, the challenges facing urban water management in developing countries including climate change, the concept of integrated water resources management, and the framework for integrated urban water management in the Middle East and North Africa (MENA) region, including the salient socio-economic and environmental stresses and trends that will drive and condition water supply and demands over the coming decades. It is concluded that approaches for advanced international and intersectoral cooperation and for identifying and strengthening intellectual and technical resources, tools, lessons, and best practices should be shared, applied, or adapted across the region. Finally, recommendations are made for improved management of water resources in MENA countries.

**Keywords** Integrated urban water management • Privatization • Regional and international collaboration • Urban water cycle

## Acronyms and Abbreviations

AfDB	African Development Bank
BCM	Billion Cubic Meters
DSS	Decision Support System
GIS	Geographic Information System
ICA	Institutional Capacity Assessment
IFC	International Finance Corporation
IMF	International Monetary Fund
IPCC	Intergovernmental Panel on Climate Change
IUWM	Integrated Urban Water Management
IWM	Integrated Water Management
IWRM	Integrated Water Resources Management
MENA	Middle East and North Africa
NRW	Nonrevenue Water
O&M	Operations and Maintenance
SUWM	Sustainable Urban Water Management
UASB	Upflow Anaerobic Sludge Blanket

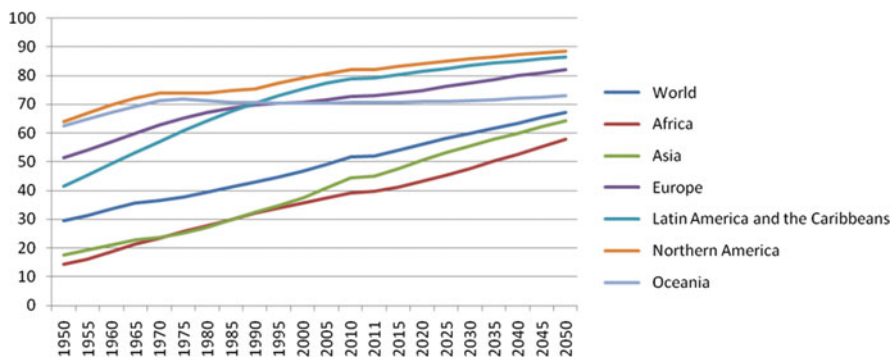
UNDP	United Nations Development Program
USGS	US Geological Survey
USSWM	Urban Sustainable Sanitation and Water Management
WHO	World Health Organization
WRIS	Water Resource Information System

## 1 Introduction

Since the earliest civilizations, water has two uses – irrigation and domestic use (domestic use can also be considered potable use). Managing water has been fundamental to the development of human societies in the Middle East and North Africa (MENA). In the cradle of civilization, the legal codes governing the cities of ancient Mesopotamia – recorded in the Code of Ur-Nammu (ca. 2100 BCE) and the Code of Hammurabi (ca. 1750 BCE) – prescribed obligations for the proper use and maintenance of common waterworks. In classical antiquity, the Greek historian Herodotus described Egypt as the gift of the Nile’s floods and flows. In the text that forms a doctrine for the governance, a sentence urged the population to respect the holy river and preserve it from pollution.

In the fourteenth century, the great Tunis-born statesman and scholar, Ibn Khaldun, first sought to decipher a pattern in the cycles of human political and social organization. He maintained that dynasties endured by establishing cities, ensuring urban life as the highest form of civilization, and named the provision of freshwater as one of the few critical requirements for siting cities, blaming the failure to adequately secure this natural necessity for the ruin of many Arab towns.

Urbanization is one of the most important demographic trends of our time. In 2008, the number of people living in urban centers worldwide has, for the first time, surpassed the number of those living in rural areas. It is estimated that by 2050, the percentage of the urban population will reach nearly 70 % [1] (Fig. 1). The four



**Fig. 1** Urbanization trends and estimates in major regions of the world (in % from 1950 to 2050) [2, 3]

main factors responsible for urban growth are the natural demographic growth of urban populations, the absorption of rural settlements located at the edges of expanding cities, the transformation of rural towns into urban centers, and the migratory movements from rural areas to cities.

Urbanization represents a challenge for water and sanitation management in developed as well as in developing countries. While cities in developed countries often struggle with high operation and maintenance costs and the decay of existing infrastructure, rapid urban growth in the developing world is seriously outstripping the capacity of most cities to provide adequate services for their citizens [4]. In rapidly growing urban slums, where there is no planning and few facilities, the number of people living without access to basic water and sanitation services is increasing. This is of particular concern considering that the WASH (water, sanitation and hygiene) sector represents the foundation on which broader goals of poverty reduction, environmental sustainability, social development, and gender equality must be built [1].

In modern times, worldwide, irrigated agriculture accounts for 70–80 % of water withdrawals. Industrial use (including energy) amounts to an estimated 20 % of total water use, although this is increasing in urbanizing economies. The proportion of domestic water (potable) use is approximately 10 % of the total. But, industrial and domestic water demand is expected to double by 2050 [5], and competition over water sources will escalate.

In this chapter, we discuss the urban water cycle and water consumption, the challenges facing urban water management in developing countries including climate change, the concept of integrated water resources management, and the framework for integrated urban water management in the Middle East and North Africa (MENA) region, including the salient socioeconomic and environmental stresses and trends that will drive and condition water supply and demands over the coming decades. Approaches for advanced international and intersectoral cooperation and for identifying and strengthening intellectual and technical resources, tools, lessons, and best practices should be shared, applied, or adapted across the region. Finally, recommendations are made for improved management of water resources in MENA countries.

## **2 Water Resources and Urbanization**

### ***2.1 Urbanization and Water Cycle***

Figures 2 and 3 illustrate the overall urban water cycle, showing the main components and pathways. The process of urbanization often causes changes in groundwater levels because of a decrease in natural recharge and increased withdrawal [6, 7]. How does the urbanization process change the water budget from



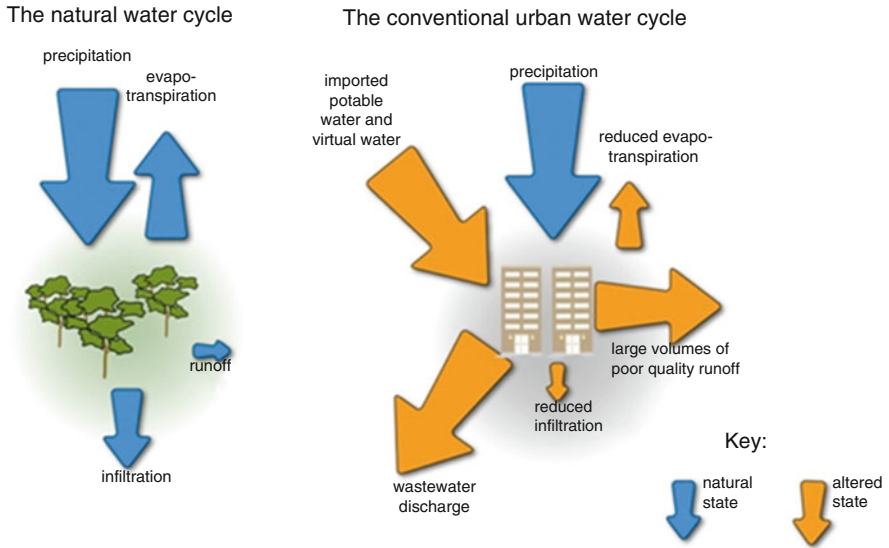


Fig. 2 Major differences between the natural water cycle and the conventional urban water cycle (Source: [6])

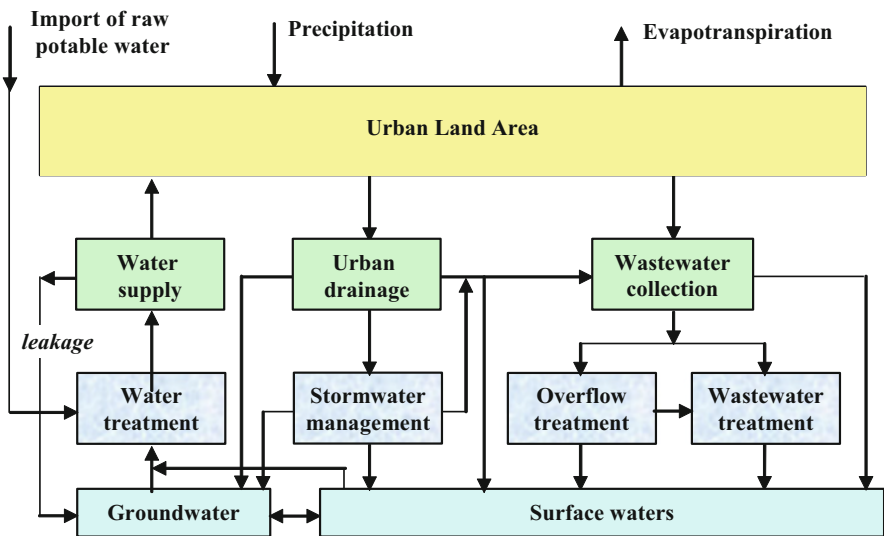


Fig. 3 Urban water cycle – main components and pathways (Source: [7])

predevelopment to developed conditions of the urban water cycle in arid and semiarid regions? This change is a very complex process and difficult to explain [8]. Details are described under Sect. 3 of this chapter.

## 2.2 Urbanization and Water Consumption

The need for water is derived from a variety of activities as shown in Fig. 4. These activities are vital for the existence and development of human society. Because usable water is limited in its availability, it has an economic value. Furthermore, different activities require water of different quality. For example, water of high quality is needed for domestic use while quality may be compromised for sanitation use. Clearly, all uses of water cannot be supported to the fullest extent, and a management policy has to be developed that can prioritize water use following established criteria. There may be conflicts and interactions among different water uses, and these, in turn, interact with water elements. Management policy has to incorporate all these considerations.

## 2.3 Challenges Facing Urban Water Management

### 2.3.1 Consequences of Globalization

In today’s integrated global economy, with its innovations in telecommunications and transportation, spatial proximity is no longer a prerequisite for economic activity, and financial deregulation has made capital mobile [10]. “World cities” [11, 12] have emerged as centers that provide financial and other specialized services for firms and businesses, environments for innovation and manufacturing, and markets for end products at the global scale [13].

In some regions, “growth triangles” and “urban corridors” are emerging as economic engines for chains of cities. For example, in South Africa, the Gauteng corridor forms an axis through Pretoria, Johannesburg, Witwatersrand, and Vereeniging [14]. Urban corridors can span national boundaries – in West Africa, the

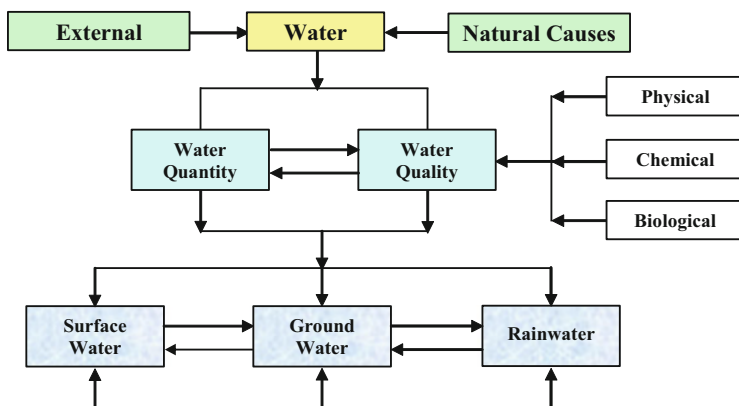


Fig. 4 Sources and quality of water from the perspective of its use (Source: [9])

Ibadan–Lagos–Cotonou–Lome–Accra corridor is developing into a megacity region, offering sites for residential and industrial development that are removed from the pollution, congestion, and high land prices of city centers yet have ready access and logistical connections to markets and services [14].

In other parts of the world – often those with lower initial levels of per capita income – urbanization appears less associated with economic development. In some countries in Africa (e.g., Nigeria, Ghana), for instance, urbanization is described as driven by poverty, as opposed to industrialization and economic growth [10, 14]. In such areas, urban populations may become socially polarized, and certain communities may become marginalized.

This situation may be exacerbated under the current global economic climate if there is less funding for urban infrastructure projects, which are capital intensive. Furthermore, unemployment is expected to rise, particularly in sectors associated with urban areas, such as finance, construction, manufacturing, tourism, services, and real estate. Rising unequal access to necessities of life such as potable water and sanitation services and poverty often follow.

### **2.3.2 Urban Sprawl**

About one-third of the world’s urban population lives in slum conditions. These settlements tend to emerge on peripheral land that provides the city with critical services, including flood control. Here, land tenure arrangements are frequently insecure, and housing quality is poor [15]. The settlements often lack access to electricity, solid waste management, sanitation, and water supply. As cities grow, they may swallow outlying towns and erase the rural-urban.

This urban sprawl poses a range of challenges for urban planners. It causes congestion and environmental degradation and increases the costs of service delivery [16]. In several middle- and low-income countries, urban sprawl is exacerbated by urban primacy – the tendency of a significant segment of the national population to reside in a single urban center, often the capital city [10, 16].

### **2.3.3 Wastewater Generation**

Use of water resources generates many types of wastewater, depending on the type of water consumption – household, industrial, agricultural, or municipal. Sustainable water management in urban areas can be achieved by including wastewater management which is the responsibility of all stakeholders – state, local communities, users, operators, and NGOs. Iacob [17] describes the role, the importance, and the steps to be followed in establishing wastewater management as a component of integrated management in urban areas.

### 2.3.4 Water Quality Monitoring

Water scarcity problems, exacerbated by poor water quality, may limit the volume of water available for specific uses. Degradation often results from human activity – intensive agriculture, resource-heavy industries, and rapid urbanization – that distorts natural water cycles and processes across the rural-urban spectrum. In cities, for example, the concentration of built-up impermeable areas means that less water infiltrates to groundwater. Furthermore, the volume of surface runoff increases resulting in the base flows of streams to decrease. Resulting stormwater flows can convey greater amounts of pollutants, which reduce water quality [18].

To ensure available water is safe for human consumption, water quality must be monitored. Figure 5 shows a schematic of facets of water quality monitoring. Monitoring and modeling of water quality variations require, among other things, detailed knowledge of hydraulics and hydrology of the water body. In case a program is launched from an operational point of view, the periods of worse conditions, such as summers when the flows are small, and the times when the concentration of pollutants is likely to be highest should be given more attention.

### 2.3.5 Drivers Influencing Water Service in Urban Areas

Although researchers are careful to emphasize that cities have unique sociopolitical and biophysical circumstances, typology does indicate how various drivers can influence the service delivery functions of urban water systems and provides a “mental model” for sustainability in the urban water sector in Australia which has yielded a typology of “transition states,” shown in Fig. 6 [19].

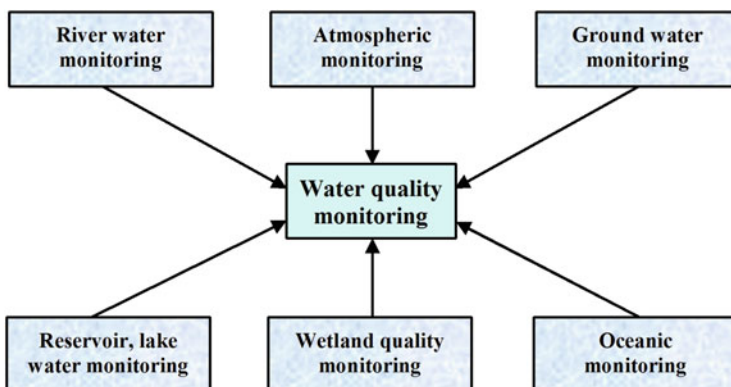


Fig. 5 Facets of water quality monitoring (Source: [9])

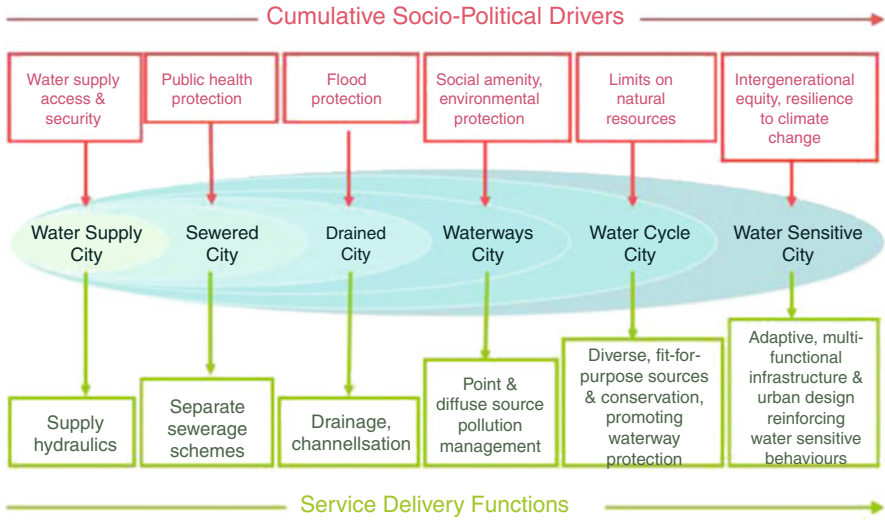


Fig. 6 Transitions from water supply cities to water-sensitive cities (Source: [19])

### 2.4 The Climate Change Challenge

The water management crisis is unfolding against a backdrop of climate change. The latest Intergovernmental Panel on Climate Change (IPCC) Assessment Report [20] called the evidence for global warming “unequivocal” and forecasted warming of 1.8–4.0 °C by 2100. Land areas may experience warmer temperatures, more frequent heat waves, less precipitation, and more intense precipitation over a shorter period. Areas affected by drought are expected to expand. Some regions will see intense tropical cyclones, and coastal areas will face rising sea levels. Low-elevation coastal zones account for a mere 2 % of the world’s total land area yet host an estimated 13 % of its urban population [21]. Water is the main conduit for climate change effects in urban areas [22]. Freshwater hydrology will be among the systems most affected by climate change [20].

As global temperatures rise, central and eastern parts of sub-Saharan Africa may experience more flooding and associated damage to water supply and sanitation infrastructure. Southern Africa, which has a significant amount of piped water supply and sewerage, is expected to experience declining average rainfall; urban areas will have to manage demand and reduce leaks and other lost water. Reduced rainfall also poses a threat to the Sahel and southwestern sub-Saharan Africa.

Northern Africa and the eastern Mediterranean regions – that are already dry – are also likely to experience further declining average rainfall. The region has high rates of piped water and sewerage and will have to prevent unsustainable rates of groundwater withdrawal, particularly for urban water supply. Desalination is becoming more common in these regions; future energy supply and costs, as well as greenhouse gas emission targets, will influence the continued contribution of

desalination for water supply. South Asia is likely to see an increase in average precipitation and more intense 5-day wet weather events. The consequent risks of flooding have serious implications for most types of water supply. Elsewhere, glacial meltwater may be threatened by accelerated warming.

Until recently, urban issues were largely absent from international climate change policy discussions. Now, cities across the globe are devising adaptation and mitigation measures, including strategies to improve the resilience of their water sector.

#### **2.4.1 Climate Change Impact on Urban Areas**

Informal settlements and slums, which tend to emerge near rivers, streams, and coastlines, offer informal access to water, can disrupt the aquatic system, and deprive the city of critical ecosystem services, including flood control. With the parallel increase in built-up areas and consequent imperviousness of urban land surfaces, natural infiltration and stormwater flows are disturbed [23].

In 2011, for example, heavy monsoon rains and successive tropical storms caused protracted flooding in Bangkok. Over the years, rapid urbanization and development in the city and its surroundings had shrunk flood retention areas and floodplains [22]. The city is located in a flat, marshy delta, and several of its neighborhoods lie below sea level, making it among the most vulnerable capitals in Southeast Asia [24]. The Bangkok case illustrates the struggle that many cities – particularly in the Global South – face in ensuring that urban growth does not undermine environmental protection and public safety.

Table 1 shows the range of climate hazards that cities are likely to face, along with their effects on urban systems.

#### **2.4.2 Climate Change and Water Supply**

Climate change is likely to affect water supply technologies, primarily through flood damage, increasing treatment requirements, and reducing availability and operational capacity. Extended dry periods will increase the vulnerability of shallow groundwater systems, roof rainwater harvesting, and surface waters. Most drinking-water supply technologies that are vulnerable to climate change show at least some adaptive potential.

Among the technologies considered improved under the WHO/UNICEF Joint Monitoring Programme for Water Supply and Sanitation, tube wells (used mainly in Asia) show relatively high resilience to climate change; protected springs and small piped supplies appear to be resilient to a lesser degree; and dug wells and rainwater harvesting are even less so. Water supplies that are managed by utilities have high potential resilience and adaptive capacity – much of which is not yet realized. Water supplies that are managed by small communities are considered highly vulnerable [26].

**Table 1** Climate hazards and their effects on urban systems [20, 25]

Climate hazard	Effect	Vulnerable system	Possible consequences
Decreased precipitation	Water scarcity	Water supply	Water shortages for households, industries, and services
		Human health	Malnutrition and increase in waterborne diseases
Increased precipitation	Reduced streamflow	Food production	Reduced availability of irrigation water and yield decreases: food import
		Urban green space	Reduced biodiversity and ecosystem services
		Energy supply	Reduced hydropower generation potential: disruption of thermal power plants' cooling systems
		Food production	Negative impact on coastal fisheries due to decreases in the outflow of sediments and nutrients
		Water supply	Disruption of public water supply
		Wastewater	Infrastructure damage and contaminated water
Higher temperatures	Increased erosion and sediment transport	Transportation	Damage to transport infrastructure
		Built environment	Disruption of settlements, commerce, transport, and societies: loss of property
		Water supply (reservoirs)	Sedimentation and decrease in water storage capacity and turbidity increase
		Water supply (lakes, reservoirs)	Reduced water quality (e.g., algal blooms); the increase in treatment requirements
Sea level rise	Storm surges, flooding	Water supply (rivers)	Change in peak-flow timing and magnitude
		Water supply infrastructure	Increase in treatment requirements to remove odor and taste
		Water supply (groundwater)	Decreased freshwater availability due to saltwater intrusion: water source abandoned
		All	Damage to all coastal infrastructures: costs of coastal protection versus costs of land-use relocation: potential for movement of population and infrastructure

### 2.4.3 Climate Change and Sanitation

Where rainfall intensity and flooding increase, climate change will impose additional costs on stormwater drains, dams, and levees and may render certain areas uninhabitable. Flooding may damage sewers. In cities with combined stormwater and sewage systems (CSOs), flooding may overwhelm treatment facilities and create public health risks [23]. Rising groundwater levels may make pollution from pit latrines difficult to manage [27].

Flooding may also contaminate water supplies, leading to increased incidence of diarrhea and respiratory illnesses [21]. Of the sanitation technologies classified as improved under the WHO/UNICEF Joint Monitoring Programme for Water Supply and Sanitation, pit latrines are more resilient because they can be redesigned. Individual facilities, in general, are less resilient. Where groundwater levels rise, however, pollution from pit latrines becomes difficult to control.

Modified sewerage, which includes simplified options, such as “small bore,” “shallow,” and “condominium” sewerage, is typically lower cost than traditional sewerage, functions with less water, and is expected to be more resilient in the face of a wider range of climate scenarios.

## 2.5 Response Options to Climate Change

There are different schemas to align with the broader goals of sustainable development [28, 29] conflicts and trade-offs. The restoration of urban green spaces, for example, serves both urban mitigation and adaptation: not only do these areas sequester carbon, but they also protect urban areas from damage associated with extreme weather events [21]. Comprehensive action to deal with climate change must account for the temporal and spatial scales at which mitigation and adaptation occur. The heavy concentration of people and economic activity in cities makes mitigation and adaptation programs both feasible and necessary.

Preparing for climate change requires an integrated approach. To determine climate vulnerability and improve resilience, for example, planners must view urban water management in conjunction with the built-up regional environment, pollution control policies, and solid waste and stormwater management.

## 3 Integrated Water Resources Management

Throughout the world, the management of water in cities is confronted with rising challenges. Water demand is increasingly outstripping supplies as urban populations expand and economies grow; flooding is becoming more frequent as urbanization spreads and natural hydrological regimes are altered; the health of



citizens, particularly in low-income neighborhoods, is jeopardized as a lack of adequate water and sanitation services which causes outbreaks of waterborne diseases. Deteriorating infrastructure, increasing fuel costs, and the impacts of climate change further amplify the pressures on urban water systems.

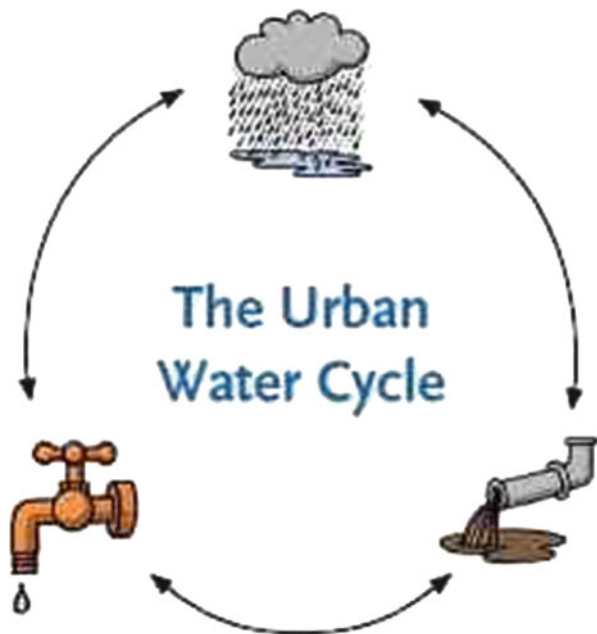
### 3.1 *Integrated Urban Water Management Doctrine (IUWM)*

Composed of different elements, urban water resources and their use are all part of a single system – the urban water cycle – which in itself is inextricably linked to the larger watershed (Fig. 7).

Integrated urban water management (IUWM) projects require significant levels of funding for both capital and operations and maintenance costs. For countries with limited ability to invest in water infrastructure, appropriate policies and well-functioning institutions make fundraising easier. Adopting IUWM and its adaptive, iterative processes will help cities significantly reduce the number of people without access to water and sanitation by providing water services of appropriate quantity and quality, thereby improving the health and productivity of urban residents.

Societies across the MENA region have long balanced the water demands of households, industry, and agriculture. Careful management of water resources has been an absolute necessity in this region where annual renewable water supplies

**Fig. 7** The three basic components of the urban water cycle (Source: [30])



average about 623.8 billion cubic meters (BCM), compared to Africa's 3950 BCM, Asia's 12,009 BCM, and the world total of 43,764 BCM [31]. But, recent developments, e.g., population growth, migration, industrialization, urbanization, pollution, global warming, and other environmental changes, have imposed substantial stress on societies and challenged policymakers, scientists, engineers, and planners alike. Today, growing water demand, decreasing water availability, and deteriorating water quality affect environmental quality, food security, municipal infrastructure, economic development, and overall human security in most societies of the MENA region. Transboundary tensions threaten international peace and stability.

These strains pose serious challenges to regional prosperity and social order. It is no exaggeration to say that water policy and water security are as a central determinant of the future well-being of the MENA countries as is governance or ideology. To date, international and domestic responses to water scarcity issues have largely focused on bolstering supply rather than reducing demand via measures that encourage or mandate greater water conservation. Augmenting supply allows governments to at least partially circumvent various political and ethnic tensions that often accompany water access.

Focusing on conservation and greater water-use efficiency, meanwhile, has a much higher potential to trigger grievances, particularly among politically influential factors in the agricultural sector who may have become accustomed to unrestricted surface water and groundwater pumping for irrigation. Sullivan [32] presents an indicator for scarcity or poverty and states that a suitable or successful IWRM is based upon a water poverty analysis for a specific country or city.

Integrated water resources management (IWRM) strategies seek more balanced consideration of both supply and demand dynamics, coordinating between multiple uses, stakeholder claims, and ecosystem needs, as well as across geographic areas. Policymakers increasingly view the approach as not only a better way to manage water but also as a more effective means to super cooperation between riparian states. IWRM is based on the philosophy that all uses of water are interdependent and that water exists both as a social and economic good. For instance, agricultural runoff can pollute aquifers and rivers, leading to poor-quality drinking water and environmental degradation and, conversely, limiting agricultural water withdrawals for ecological reasons.

### **3.2 *Water Resource Information System (WRIS)***

Water resource information system (WRIS) is a means with which to manage current and historical hydrological and related data in an organized form [9]. The primary role of a WRIS (Fig. 8) is to provide reliable data sets, such as water resources, demography, and water use for planning, design, and management of water resource and for research activities. The system should function in such a manner that it provides the information to users in a timely manner and in proper form. Sometimes, the scope of WRIS is extended to provide data to users on a real-time basis for short-term forecasting or operational purposes.

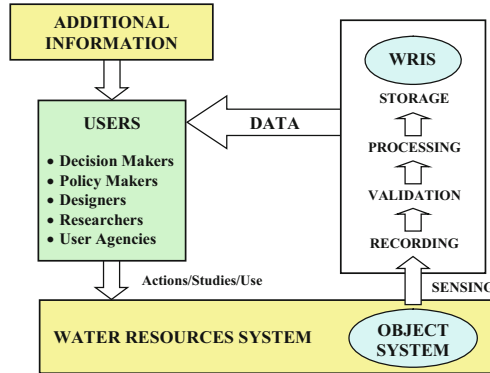


Fig. 8 Schematic diagram of a water resource information system (Adapted from [33])

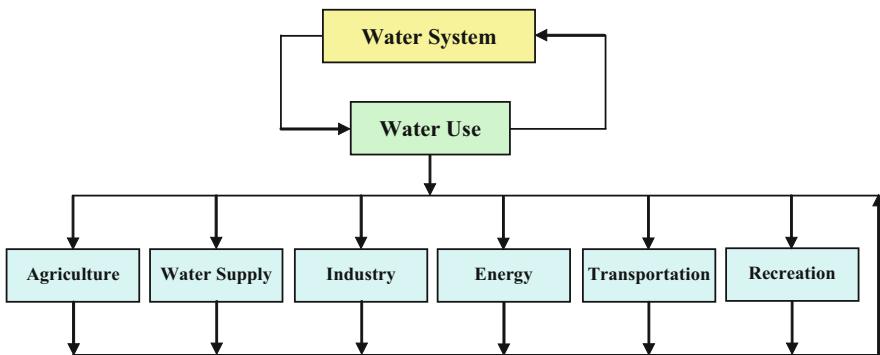


Fig. 9 Elements of a water system and their interactions (Source: [9])

### 3.3 Elements of Integrated Water Resources Management

Water elements, their interactions, and the effects of natural as well as external constraints on them, as shown in Fig. 9, constitute the foundation upon which the edifice of integrated water management is built. External constraints, such as economic, demographic, transportation, and other forms of development, directly influence one or the other water elements. Likewise, climatic vagaries, climatic change, and climatic extremes and a host of natural hazards, such as the excise use of pesticides, are some of the natural causes that greatly influence the water elements and have a significant impact on the integrated water management.

Once a management policy is established, a strategy, including administrative infrastructure, has to be employed to undertake integrated water management as shown in Fig. 10. The components of integrated water management are interactive, and hence the administrative setup must be flexible and responsive to changing goals. Thus, integrated water management requires integration of the various

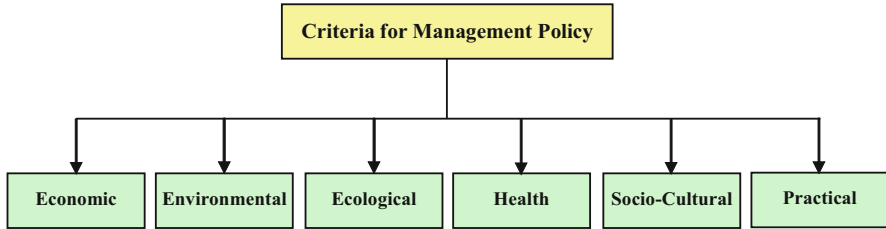


Fig. 10 Criteria for foundation of a management policy (Source: [9])

components – physical, biological, chemical, social, economic, ecological, health, and environmental. This can be accomplished through development and application of mathematical models. Physical, chemical, biological, environmental, and ecological components and their models must be embedded in the development of comprehensive watershed models.

### 3.4 Ecosystem Services

Urban centers rely on wetlands and aquatic ecosystems for services, such as oxygen production, carbon storage, natural filtering of toxins and pollutants, and protection from coastal flooding or landslides and other storm-related disasters [21]. Aquatic systems dilute and transport pollution away from human settlements, maintain the quality of freshwater sources, and, in some cases, permanently remove pollutants from the atmosphere.

Unsustainable water resources management and excess pollution are eroding these services, however, compromising clean water supplies and food production [22, 34, 35]. Freshwater ecosystems are among the most degraded on the planet [22]. Because of the interconnectedness of aquatic systems, changes in local aquatic ecosystems can have downstream consequences.

### 3.5 Policy Responses

Despite the interconnections among water quality, water consumption, wastewater, and the ecosystem services provided by aquatic systems, each of these issues is frequently addressed independently [36]. These strategies are inefficient and may be unsustainable. Some cities, for example, have created large-scale transfer schemes that convey water from rural agriculture, ecological reserves, and surrounding aquifers or have constructed large dams. Where ecosystems have been degraded, cities have often turned to engineering solutions – large water storage and treatment facilities or river basin transfer scheme to compensate for the lost

services. These projects are expensive, however, and do little to halt unsustainable and polluting water use.

MENA countries take different approaches, regarding the law which was developed to protect the waterway. For Egypt, Law No. 4 for environment protection was issued in 1994 and amended by Law 9/2009 [37]. The law asks for very low pollutant discharge in waterways. As a result, countries like Egypt, Lebanon, and Iraq suffer from waterway pollution coming from the industrial drainage of wastewater in the waterways.

### ***3.6 Economic Costs and Benefits***

While global water resources may be finite, the same cannot be said of water demand [32]. Growth in human populations is creating an increasing demand for water, and if, at the same time, standards of living rise, water consumption per capita is also likely to rise. This means that water resource availability, or lack of it, is linked to economic and social progress, suggesting that development is likely to be influenced by how water resources are managed. At a national level, countries which have higher levels of income tend to have a higher level of water use [38].

Demand management is one of the real challenges faced by policymakers today. On a global scale, water for agriculture is by far the most important use, with domestic water requirements being just a fraction of the total. Even taking the very arid countries in the Middle East, this pattern still tends to occur. While there is some scope for better management of domestic water, there is little doubt that better water management in agriculture is likely to have the greatest impact on water resource availability. The complexity of the problem of water resource allocation can be illustrated by looking more closely at three countries (Jordan, Qatar, and Syria) in MENA region. For example, in Jordan, rapid industrialization and population growth have led to water demand being on the verge of exceeding water supply [39].

Recognizing the limits of the conventional “model” of direct state delivery systems, an increasing number of Asian countries have begun to adopt an alternative, community-based approach to providing basic infrastructure and services in low-income settlements. Reorienting the conventional method of alternative, community-based approaches, however, requires development of a ready availability of funding and technical and legal assistance to individuals, households, and communities [40].

### ***3.7 The Role of the International Organizations***

In the 1990s, many governments in Latin America and Eastern Europe, as well as a few countries in Africa and Asia, embraced liberal economic policies. The

International Monetary Fund (IMF) and the World Bank Group, which includes the World Bank proper and the International Finance Corporation (IFC), were key players in this endeavor. All three are owned by their members, which include almost all countries of the world, but they are often perceived as a tool of Western governments who are said to dominate them [41].

There was some merit to this argument at the time of the Cold War. Today, while the president of the World Bank is still traditionally an American, about half of the voting rights are held by developing and emerging countries, in line with their increased share in the world economy. Also, more than half of the World Bank's current staff are from developing and emerging countries. The three entities have different, sometimes overlapping mandates in developing and emerging countries.

The *International Monetary Fund* works like a “firefighter” during financial crises, quickly providing massive short-term loans when needed. It attaches broad and general “macroeconomic” conditions to these loans, including some concerning privatization.

The *World Bank* proper provides long-term loans and, for the poorest countries, grants for investment projects, as well as some for budget support. These loans and grants are sometimes coupled with “microeconomic” conditions that often focus on specific sectors of the economy. The World Bank's employees often work for many years in one sector. Through the preparation and supervision of investment projects, many of them nurture long-term relationships with professionals in their partner countries.

Due to the nature of their work, they often gain considerable knowledge of water supply and sanitation in these countries. While the World Bank works with governments and state-owned companies, the *International Finance Corporation* has the mandate to support the private sector in developing countries. It thus is structurally different – while the World Bank proper can help governments to strengthen publicly managed utilities or to establish public–private partnerships, the IFC exclusively supports private companies.

In line with this mandate, the IFC has been involved in water privatizations in Eastern Europe and in emerging countries, especially the larger ones, including the concessions in Manila and Buenos Aires. Compared to the World Bank, the IFC's corporate culture is closer to a commercial bank. Its employees are highly skilled at analyzing commercial risks and structuring financially complex projects, but they are typically not as deeply involved in one sector as World Bank employees are.

### **3.8 Privatization of Water**

Having a private water company take over a local water supply system brings up elementary fears. Will private water companies overcharge their customers? Will they cut off those who cannot afford to pay? Will they cut corners, compromising water quality or service quality, letting infrastructure deteriorate for the sake of

higher profits? Only a few people ask other questions: Could private companies perhaps bring about improvements, beyond and above what publicly managed companies have achieved? Where private companies have been brought in, have they served the people better or worse than publicly managed service providers? Some people may not be much interested in the empirical evidence about water privatization because they already know the answers. The privatization issues are fully discussed by Schiffler [41] who analyzes the reasons and the impact of the privatization of water and sewer systems in 12 countries.

## 4 A Framework for Integrated Urban Water Management

The integrated water resources management approach has proven to be a suitable option for efficient, equitable, and sustainable water management [42]. In water-poor regions experiencing acute and chronic shortages, optimization techniques are a useful tool for supporting the decision process of water allocation. To maximize the value of water use, an optimization model was developed which involves multiple supply sources (conventional and nonconventional) and multiple users.

Penalties, representing monetary losses in the event of an unfulfilled water demand, have been incorporated into the objective function. This model represents a novel approach that considers water distribution efficiency and the physical connections between water supply and demand points. Subsequent empirical testing using data from a Spanish Mediterranean river basin demonstrated the usefulness of the global optimization model to solve existing water imbalances at the river basin.

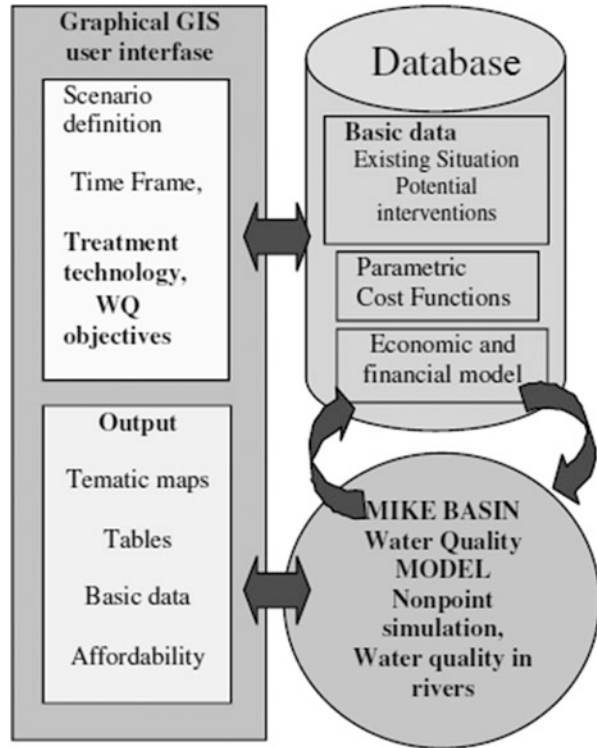
### 4.1 *Components of the Decision Support System (DSS)*

The decision support system (DSS) comprises databases and models and functions as an integrated and user-friendly tool to evaluate alternative options for compliance considering legislative requirements, technical options, environmental impacts, and economic/financial implications [43]. The essential components of the DSS are shown in Fig. 11. The DSS facilitates access to relevant information on the national scale and provides a computational capability for the analysis and evaluation of different options to assist in the identification of viable strategies.

The system is comprised of the following components:

- *Database* providing an overview of pollution sources (municipal, industry, and nonpoint), receiving waters, existing water quality and hydrological conditions, water supply and wastewater treatment facilities, technical options for improvements, basic statistical data and topographical data, etc.

**Fig. 11** Components of the decision support system  
(Source: [43])



- *Parametric cost functions* for the different technical options showing the required investments and annual operation and maintenance (O&M) costs as a function of the number of person equivalents and required effluent standard, in the case of treatment or water supply facilities and connectivity of inhabitants.
- *The MIKE BASIN water resources management and water quality models* for determining the load from nonpoint sources and simulation of the resulting water quality conditions as a consequence of assigning different treatment levels to the individual point sources. The model also accounts for the corresponding investments and O&M costs. The simulation models may be used within an optimization procedure.
- *Optimization model* to identify least-cost strategies for meeting specified ambient water quality objectives.
- *Economic and financial model* for determining the net present value of compliance costs, covering capital investment plans and associated O&M costs in both economic and financial terms.
- *Graphical/GIS interface* allowing a user-friendly specification of the scenarios to be analyzed as well as an easy retrieval of the results generated by the models.

Basic topographic information for the DSS is stored as layers in ArcView GIS<sup>TM</sup>, such as digitized map of the study area including the river network and



digitized map of districts and the borders of sub-catchments. Connected database holds other information, such as codes for locating information within the approximately 400 subbasins in the MIKE BASIN model of the Czech Republic.

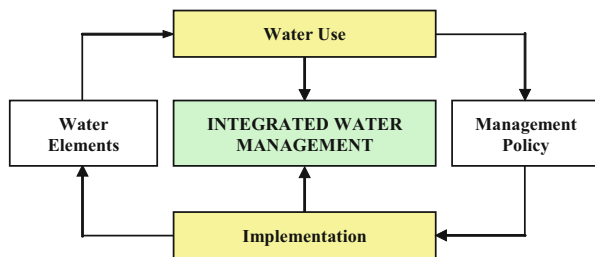
### 4.2 Integrated Urban Water Management

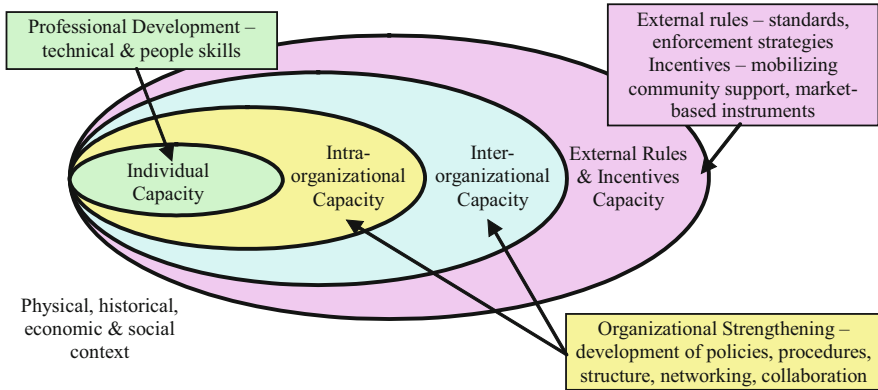
A model for integrated water management helps develop implementable solutions to water resources problems by combining into an optimization scheme all the essential component models. The model incorporates or accumulates all of the interactive forces or influences. Hence, it aids the decision-making process and keeps the policy results within the intersection of the social goals of the management policy and the legal constraints. Such a model is shown in Fig. 12.

The framework emphasizes the linkages within the urban water cycle. When ignored, the interactions between the different elements of the urban water cycle can affect each other negatively, while at the same time, positive synergies can be missed [44]. To capture the complex interactions and linkages, modeling tools for IUWM are required to predict the impacts of possible interventions throughout the system. There are a number of different decision support and scoping models (e.g., CITY WATER, AQUACYCLE, UVQ UWOT, MULINO, HARMONIT, DAYWATER) that can support IUWM by enabling the assessment of the dynamic balances of water, energy, and pollutants at the city scale. These tools are designed to provide guidance on the potential short- and long-term impacts of innovative technologies and systems for urban water management and can help identify system configurations that minimize water consumption, costs, and energy.

Institutional capacity refers to the ability of the whole institution, from individuals through organizations and the legislative and policy instruments used, to undertake a task, in this case, sustainable urban water management. Institutional capacity assessment (ICA) is essential to form coherent strategies for investment in capacity development and water reform. The most recent ICA framework developed in urban water draws on public administration and urban management literature [45]. It is a nested model of four interrelated capacity spheres and links each sphere to capacity-building interventions to advance sustainable urban water management (SUWM) (Fig. 13).

**Fig. 12** Integrated water resources management  
(Source: [9])





**Fig. 13** Institutional capacity assessment framework and capacity-building initiatives for sustainable urban water management (Source: [45])

### 4.3 *Creating an Enabling Environment for IUWM*

In its core, integrated urban water management is about balancing objectives, prioritizing goals over different time frames, and taking practical measures deployed in concert by a range of organizations. Therefore, it requires an institutional context in which public and private factors can work together, supported by coherent legislative and policy frameworks.

Indeed, the success of IUWM rests on cross-scale and cross-sectoral linkages; it is not the remit of cities or the water sector alone. High degrees of internal integration and alignment between various levels of resource management are characteristic of emerging “green” or “sustainable cities.” These cities draw on a range of tools to catalyze coordination, including resource-wide budgets and citywide integrated plans.

### 4.4 *Roles for Central Governments*

During the 1990s, when public service provision was deemed a failure in terms of efficiency, market approaches were expected to improve efficiency, create new financial flows, and deliver greater accountability [5]. Although the corporate sector has, in places, improved the efficiency of service delivery, it has been less capable of meeting equity goals. According to UN-Habitat [16], the present global financial crisis has highlighted some of the limits of market-led approaches and reignited interest in stronger government involvement to ensure that basic needs are met.

The fluctuations in global energy and food prices may compel central governments to exert a greater regulatory role over market forces, particularly where the cost of daily living has soared beyond the means of vast swaths of the population.

As a whole, government measures complement – but do not replace – private efforts, whether formal or informal, or led by the community, the civil society, or the corporate sector.

Central governments provide countrywide perspectives on urbanization and water management by setting national policies on land and infrastructure services and other issues that affect the entire rural-urban continuum. In choosing to make policy for broad economic areas that integrates villages, towns, and cities, governments can even out the differences in living standards between rural and urban areas [15].

#### ***4.5 Roles for Local Governments***

Urban governments devise policies and strategies for prioritizing, sharing, and managing available resources while taking into account local demands. To be successful, they must look beyond the water sector in isolation. Policies on housing, energy, land use, urban and rural agriculture, and waste management all have a bearing on the sustainable management of water.

Urban governments can engage the various water users in analyses, choices, and decisions related to water resources. They can ensure that decisions about new water sources, particularly for cities with high water demands, do not deprive surrounding areas. Local governments need to foster a culture of long-term planning that looks beyond short-term financial calculations.

#### ***4.6 Private Sector Involvement***

In the late 1990s, a wave of privatization swept through the world, starting in England in 1989 and then moving to Latin America, parts of Asia, and – to a lesser extent – Africa. These privatizations were based on the assertion that the private sector would be more efficient, more customer oriented, and better able to raise financing than the fledgling public sector (privatization of water is discussed in Sect. 3.8).

#### ***4.7 Business Opportunities Along the Entire Value Chain***

Food security is heavily dependent on fertilizers. The rising price of artificial fertilizers and dwindling phosphate reserves have created a market opening for organic fertilizers from animal manure, human excreta, and other bio-wastes. In Malawi, for example, private on-site service providers give credit to households

that are otherwise unable to build composting toilets, against future “manure” sales. These activities contribute toward “closing the loop” in managing nutrients, land, and water, thereby helping rebalance distorted urban metabolisms. Ouagadougou, Burkina Faso, is one of the cities that have tested the viability of a value chain for recycling urine and excreta [46].

#### ***4.8 “Urban” and “Basin” Management***

Hydrologic boundaries rarely coincide with administrative ones. Urban catchments – overseen by city authorities – may lie within basins that cross state, or even national, borders. The relationship is reciprocal: practices within the basin influence the quantity and quality of water available for cities, and urban population growth and economic development shape water flows beyond city boundaries [47]. For example, Sao Paulo has explored various governance mechanisms to integrate its management of water resources with efforts at the broader basin level.

#### ***4.9 Stakeholder Participation***

The IUWM approach depends on stakeholders’ engagement in designing and managing urban water systems. Although widely accepted in principle, stakeholder engagement can vary substantially. In some cases, it entails genuine involvement in decision-making; in others, it amounts to informing people about decisions already taken. All user groups should participate in designing or restructuring systems for basic services. Participation in project planning, municipal planning, and budgeting can ensure appropriate design and informed contributions that improve living conditions, particularly in low-income settlements.

Legal mechanisms may be needed to define the roles for stakeholders and set the conditions for the involvement of groups not traditionally considered relevant for urban decision-making [16], such as upstream farmers’ associations, industry representatives, and energy utilities [5]. In addition to forging upstream–downstream linkages, legislation can also be a vehicle for cross-sectoral integration.

Laws guaranteeing the right to wastewater encourage farmers to install appropriate treatment and irrigation infrastructure; they also establish standards for water quality and monitoring authority for public health purposes. Water users typically have different agendas that need to be reconciled. Capacity to resolve disputes must be accompanied by transparency. For example, Karachi, Pakistan – a pioneer in the implementation of IUWM within a context of a megacity – has put in place a public–private partnership to manage its water resources in a more coordinated, equitable manner.

#### ***4.10 Fostering a New Culture of Urban Water Management***

Professional cultures need to change so that they reward cross-sectoral and cross-scale cooperation. Building and maintaining collaboration among stakeholders is not a simple feat. However, ideas must be conveyed across institutional languages and operational cultures. Different levels of power, influence, and resources have to be bridged. Common goals, and the benefits of mutual action, must be clearly articulated. Such transformations must be accompanied by robust monitoring mechanisms that update authorities, service providers, and users. Successful management approaches are adaptive and nimble, so that water management systems can respond promptly to unexpected changes.

Indeed, IUWM involves learning how to act in conditions of uncertainty and imperfect knowledge. Problem definitions and underlying assumptions must be continuously revisited for their relevance [48]. Sectoral integration within government and scalar integration between levels of government are becoming increasingly important. Transforming entrenched practices can be especially difficult in megacities. Small- and medium-sized cities, on the other hand, can plant the seeds of integration now.

Managing urban water resources and integrating all aspects of water source and quality will require public education and collaboration to realize the necessary cultural and behavioral changes [49], as well as coordination among land and water management entities, resource and regulatory agencies, local governments, and nongovernmental organizations [50]. For example, New York City, USA, supplies nine million people with safe drinking water by collaborating with surrounding municipalities to protect upstream sources.

#### ***4.11 Game-Changing Technologies and Approaches***

IUWM aims to make use of innovative technological solutions for urban water systems. Practical applications of a variety of innovative technologies, such as membrane filtration systems, including membrane bioreactors, advanced oxidation, hybrid systems of natural and advanced treatment, microbial fuel cells, electrochemical processes, and source separation of different waste streams (separation of gray water, black and yellow waters), have led to new ways of managing urban water systems. The potential of more efficient reuse of water and nutrients and the recovery of energy is a major advantage of the new treatment technologies [51].

Those new technologies are, in many cases, instrumental in the concept of integrated management approaches. Moreover, IUWM offers different innovative approaches to cope with the challenges for urban water management. IUWM ensures that the technology innovations in urban water management are coupled with comprehensive system changes of the urban water system. The new approach should consider the whole urban area as unit of management with application of

**Table 2** Innovative technologies and their benefits for IUWM [44]

	Innovative technology	Benefits for IUWM
1	Natural treatment system	Adds multifunctionality (integrated treatment and environment functions) Improves environmental quality Utilizes natural element, features, and process (soil, vegetation, microorganisms, water courses, etc.) Is robust and flexible/adaptive Minimizes the use of chemicals and energy Promotes water reuse and nutrient recovery
2	Nanotechnology and microbial fuel cells	Provide access to a cheap “green” energy source (enables the capture of electrical energy directly from organic matter present in waste stream)
3	Membrane bioreactors (wastewater)	Enhance new strategy for water management to move toward water reuse Reducing plant footprint Can easily retrofit wastewater treatment processes for enhanced performances Offers operational flexibility (amenable to remote operation) Manages environmental issues (visual amenity, noise, and odor)
4	Membrane technologies (both water and wastewater)	Promote decentralized systems which minimize environmental footprint Enhance contaminant removal and encourage water recycling Minimize the use of chemicals Improve system flexibility and permit small-scale treatment systems
5	Source separation	Promotes water reuse and nutrient recovery Promotes small (decentralized) systems that can be easily managed Avoids the complications and cost of dealing with mixed wastes
6	Anaerobic fermentation (UASB)	Produces biogas Promotes the recovery of energy from wastewater

other new approaches, such as cascading uses of water, beneficiation of water (use of water-machine concepts and semi-centralized systems), decentralized systems, analyses of quantity and quality aspects in a single framework, flexible and adaptable urban water systems, etc. Table 2 provides an overview of innovative technologies that support IUWM.

#### ***4.12 Financing Potable Water Projects: Case Study in Egypt***

The MENA region has different concepts in urban water management. These concepts range from public and government-owned companies to private companies or government owned but seeking benefit. Most of MENA countries belong to the third world and suffer from many economic crises accompanied by low per capita income. Experience shows that the private sector participation in providing

potable water has not been successful, e.g., Grenoble in France, Porto Alegre in Brazil, and many other cities around the world [52]. The case study for Egypt is provided below. The case of Egypt was selected because it passes through different phases of nonprofit, governmental authorities, to independent economical authorities that seek benefit, and finally to low-profile small private companies that provide potable water in some rich resorts.

#### **4.12.1 Potable Water Facts in Egypt**

In Egypt, 98 % of the population have access to potable water, while the average coverage of sanitary treatment is 40 %. According to the holding companies that coordinate all water companies in Egypt, the potable water production in Egypt is 28 million cubic meters per day of which approximately only 60 % is accounted for and there is no accurate figure. The estimate is mainly based on personal communication with the involved companies.

The yearly production of potable water for all Egypt is 10.35 billion cubic meters per year, coming mainly from surface sources. Egypt suffers from shortage in water resources for all uses. Remote and coastal cities in the Red Sea depend on nonconventional sources such as desalination. The tariff on desalinated water is different from the surface water; it ranges from 6 to 12 Egyptian pounds per cubic meter. Also, wastewater is recycled and used in irrigation of plants like grass.

In brief, the main challenges for potable water production and distribution are:

- The pollution
- The unaccounted water due to real physical leakage or illegal connection
- The difficulty to impose a realistic tariff in a country where the poverty level is more than 40 %

The challenge for urban water management between privatization to public owned continues. According to the holding company for 26 water treatment companies, 23 still receive subsidies from the state.

#### **4.12.2 The New Approach in Egypt**

Up to 1994, potable water was provided by governmental authorities throughout the country. The tariff was fixed at 0.12 Egyptian pound (1 US\$ = 7.78 Egyptian pounds). The government provides the difference between the real cost of purification and transportation, which estimated by the government to be 0.8 Egyptian pound. The heavy subsidies of the service force the government to investigate another framework to provide the population with potable water. In the early 1990s, several studies and investigations were completed. This period coincided with the support of the World Bank for privatization of this service. A philosophical discussion was opened to describe the potable water as service or commodity. The

difference is clear; a service that the government has to provide is nonprofit to all the population. The real cost includes 40 % leakage in the water distribution network (physical and unaccounted). Also, another issue raised is the quality of water; in some cases the product was polluted and not suitable for human consumption. All these factors together coupled with the encouragement of the World Bank's advice have pushed the government to investigate development of the existing system of potable water production.

For the first time, the government has presented to the general assembly a new vision of providing water through public companies seeking profit, and each company has its own tariff to cover treatment and distribution cost. Each governorate has its own company and, theoretically, not subsidized from the state. The transition period was from 1994 up to 2005. Once this new regulation applied, many demonstrations particularly in poor villages and governorates started to appear, during 2005 only 37 demonstrations against the new system, which lead the state to continue the financial support of private companies and also permit each company to announce its tariff according to its circumstances.

## 5 Conclusions

It is clear that in addition to specific challenges of water resources scarcity, most MENA countries share the same concerns as the rest of the world. Based on the present analysis, we offer the following conclusions and recommendations:

1. Recognizing the impact of ongoing urbanization and increasing urban water demands and implementing appropriate water management policies:

The MENA region is rapidly urbanizing, changing the way water resources are utilized by public and private interests. For example, according to the United Nations, Saudi Arabian cities experienced a 34-fold increase in population from 1950 to 2010, while the country's rural population barely doubled in the same time frame. During the same period in Egypt, rural populations grew by 213 %, while urban populations swelled by 412 %. In Syria, meanwhile, rural populations grew by 282 %, while urban populations expanded by 986 %.

Rapid urbanization is frequently outpacing the extension, operation, and maintenance of the attendant water, and, in an effort to ensure basic public goods to the poor, many municipal systems supply water to consumers at subsidized prices well below the cost of providing. Some 58 % of utilities in the region apply tariffs too low to meet their operating and maintenance costs. But without adequate funding, utilities skimp on maintenance and defer network expansions, undermining service quality and reliability. The share of nonrevenue water – water that is pumped into the distribution system but then lost to leak – is significant.



2. Building public and policymaker awareness of the prevalence and impacts of increasingly water-intensive lifestyles. Public demands and attitudes toward water change with increasing prosperity.

In the MENA region, the thriving Gulf States have some of the highest per capita domestic water consumption rates in the world – between 300 and 750 l per person per day (By comparison, the UNDP reports that the average per capita daily use in the USA is 575, 200–300 l in most European nations, and less than 50 l in many sub-Saharan African states). Under business-as-usual scenarios, these rates are not sustainable.

Yet sizable publics in many high-consumption countries – and beyond – do not consider water supply an important environmental problem. According to a 2006 regional opinion survey, 64 % of respondents in Bahrain, 52 % in Tunisia, 41 % in Qatar, 35 % in Oman and Kuwait, and 31 % in UAE deemed water either not a major problem or not a problem at all. Interestingly, across the Arab world, 71 % of respondents judged that weak awareness of environmental problems itself poses a significant threat, recognizing the impact of ongoing urbanization and increasing urban water demands and implementing water management policies accordingly.

3. The MENA region is rapidly urbanizing, changing the way water resources are utilized by public and private interests. For example, according to the United Nations, Saudi Arabian cities experienced a 34-fold increase in population from 1950 to 2010, while the country's rural population barely doubled in the same time frame. During the same period in Egypt, rural populations grew by 213 %, while urban populations swelled by 412 %. In Syria, meanwhile, rural populations grew by 282 %, while urban populations expanded by 986 %. Rapid urbanization is frequently outpacing the extension, operation, and maintenance of the attendant water and sanitation infrastructures.

## **5.1 Recommendations**

In the years and decades ahead, it must be in the region's self-interest to pursue collaborative approaches to managing scarce water resources, at both the domestic level and regionally. These aims can be advanced through multiple strategies including: (1) sharing of technical data and policy learning from best water management practices, (2) strengthening networks of MENA water experts, (3) building broader and deeper cooperative relationships among MENA experts with water experts in other areas of the world, (4) demonstrating an awareness of cultural contexts and an openness to incorporating Islamic values and traditional knowledge to promote efficient and sustainable use of surface and groundwater resources, and (5) identifying and advancing intellectual and technical tools to foster greater transparency in water management, such as stakeholder dialogues and participatory consultations, joint research and field data collection and dissemination, regional-scale climate change modeling, and remote sensing data.

## References

1. Birch EL, Meleis A, Wachter S (2012) The urban water transition. Why we must address the new reality of urbanization, women, water, and sanitation in sustainable development. In: *sWH20: J Gend Water* 1:6–7. The University of Pennsylvania, Philadelphia. <http://wh20journal.com/past-issues/volume-1-number-1-april-2012/>. Accessed 27 Nov 2015
2. UN-DESA (2010) World population prospects. The 2010 revision. Population Division of the Department of Economic and Social Affairs of the United Nations Secretariat (UN-DESA), New York. <http://esa.un.org/unpd/wpp/>
3. UN-DESA (2011) World urbanization prospects. The 2011 revision. Population Division of the Department of Economic and Social Affairs of the United Nations Secretariat (UN-DESA), New York. <http://esa.un.org/unpd/wup/>
4. Cohen B (2006) Urbanization in developing countries. Current trends, future projections, and key challenges for sustainability. *Technol Soc* 28:63–80. Elsevier, Philadelphia
5. UNDP (United Nations Development Program) (2006) Human development report 2006. Beyond scarcity power, poverty and the global water crisis. UNDP, New York
6. Healthy Waterways (ed) (2011) What is water sensitive urban design? Brisbane: Healthy Waterways. <http://waterbydesign.com.au/whatiswsud/>. Accessed 27 Nov 2015
7. Marsalek J, Jiménez-Cisneros BE, Malmquist PA, Karamouz M, Goldenfum J, Chocat B (2006) Urban water cycle: processes and interactions, vol 78, IHP-VI, technical publications in hydrology. UNESCO, Paris
8. Mays LW (2009) Integrated urban water management – arid and semi-arid regions. UNESCO, Paris
9. Jain SK, Singh VP (2003) Water resources systems planning and management, vol 51, Developments in water science. Elsevier, Amsterdam
10. Cohen B (2004) Urban growth in developing countries: a review of current trends and a caution regarding existing forecasts. *World Dev* 32:23–51
11. Hall P (1966) The world cities. World University Press, London
12. Friedmann J, Wolff G (1982) World city formation: an agenda for research and action. *Int J Urban Reg Res* 6:309–344
13. Sassen S (2001) The global city: New York, London, Tokyo. Princeton University Press, Princeton
14. UN-Habitat (2008) State of African cities: a framework for addressing urban challenges in Africa. UN-Habitat, Nairobi
15. African Development Bank (AfDB) (2011) Rapid urbanization and the growing demand for urban infrastructure in Africa. Mark Brief 1:1–12
16. UN-Habitat (2009) Planning sustainable cities: global report on human settlements 2009. Earthscan, London
17. Iacob VS (2013) The wastewater – a problem of integrated urban water management. *Procedia Econ Finan* 6:436–443
18. Palaniappan M, Gleick PH, Allen L, Cohen MJ, Christian-Smith J, Smith C (2010) Clearing the waters: a focus on water quality solutions. UNEP, Nairobi
19. Brown R, Keath N, Wong T (2008) Transitioning to water sensitive cities: historical, current and future transition states. In: 11th international conference on urban drainage, Edinburgh
20. Intergovernmental Panel on Climate Change (IPCC) (2007) Climate change 2007: synthesis report. Contribution of Working Groups I, II and III to the Fourth Assessment Report of the Intergovernmental Panel on Climate Change, IPCC, Geneva
21. UN-Habitat (2011) Cities and climate change: global report on human settlements 2011. Earthscan, London
22. UN-WWAP (United Nations World Water Assessment Programme) (2009) The United Nations world water development report 3: water in a changing world. UNESCO, Paris and Earthscan, London

23. Tucci CEM (2009) Integrated urban water management in large cities: a practical tool for assessing key water management issues in the large cities of the developing world. Draft paper prepared for World Bank, July 2009
24. Yusuf AA, Francisco HA (2009) Climate change vulnerability mapping for South Asia. EEPSEA, Singapore
25. Loftus AC, Howe C, Anton B, Philip R, Morchain D (2011) Adapting urban water systems to climate change: a handbook for decision-makers and the local level. ICLEI/UNESCOIHE/IWA, Freiburg
26. WHO/UNICEF (2015) WHO and UNICEF Joint Monitoring Programme (JMP) for water supply and sanitation. <http://www.wssinfo.org/>. Accessed 21 Nov 2015
27. WHO/DFID (United Kingdom Department for International Development) (2009) Summary and policy implications vision 2030: the resilience of water supply and sanitation in the face of climate change. WHO/DFID, Geneva/London
28. McEvoy D, Lindley S, Handley J (2006) Adaptation and mitigation in urban areas: synergies and conflicts. *Proc Inst Civ Eng Munic Eng* 159:185–191
29. World Bank (2010) Cities and climate change: an urgent agenda, vol 10. The World Bank, Washington, DC
30. Philip R, Anton A, Loftus AC (2011) Strategic planning – preparing for the future. SWITCH training kit module 1. Integrated urban water management in the city of the future. ICLEI European Secretariat GmbH, Freiburg. [http://www.switchtraining.eu/fileadmin/template/projects/switch\\_training/files/Modules/Module\\_reduced\\_size/Switch\\_Training\\_Kit\\_Module\\_1.pdf](http://www.switchtraining.eu/fileadmin/template/projects/switch_training/files/Modules/Module_reduced_size/Switch_Training_Kit_Module_1.pdf). Accessed 27 Nov 2015
31. Michel D, Pandya A, Hasnain SI, Sticklor R, Panuganti S (2012) Water challenges and cooperative response in the Middle East and North Africa. The Brookings project on U.S. Relations with the Islamic World, 2012 U.S.-Islamic World Forum papers
32. Sullivan C (2002) Calculating a water poverty index. *World Dev* 30:1195–1210
33. DHV (1999) Lecture notes of hydrology project training course on HYMOS. Hydrology Project Office CSMRS Building, Hauz Khas
34. Corcoran E, Nellesmann C, Baker E, Bos R, Osborn D, Savelli H (eds) (2010) Sick water? The central role of wastewater management in sustainable development. A rapid response assessment. United Nations Environment Programme/UN-HABITAT/GRID-Arendal, Arendal
35. Mafuta C, Formo RK, Nellesmann C, Li F (eds) (2011) Green hills, blue cities: an ecosystems approach to water resources management for African cities. A rapid response assessment. United Nations Environment Programme/GRID-Arendal, Arendal
36. Van der Merwe-Botha M (2009) Water quality: a vital dimension of water security. Development planning division working paper no. 14. DBSA, Midrand
37. Ministry of State for Environmental Affairs, Egypt, Law 4 for the protection of the environment amended by law 9/2009. Environment Protection Law of Egyptian Government. <http://www.ecaa.gov.eg/en-us/laws/envlaw.aspx>. Accessed 25 Nov 2015
38. World Bank (1992) World development report: development and the environment. Oxford University Press, New York
39. World Resources Institute (1996) World resources. Oxford University Press, New York
40. Lee Y-SF (1998) Intermediary institutions, community organizations, and urban environmental management: the case of three Bangkok slums. *World Dev* 26:993–1011
41. Schiffler M (2015) Water, politics and money – a reality check on privatization. Springer International Publishing, Cham
42. Molinos-Senante M, Hernández-Sancho F, Mocholí-Arce M, Sala-Garrido R (2014) A management and optimisation model for water supply planning in water deficit areas. *J Hydrol* 515:139–146
43. Arsov R, Marsalek J, Watt E, Zeman E (2003) Urban water management – Science technology and service delivery. Springer Science + Business Media, Dordrecht
44. Bahri A (2012) Integrated urban water management. Global Water Partnership, Stockholm

45. Brown RR, Mouritz M, Taylor A (2006) Institutional capacity. In: Wong THF (ed) Australian runoff quality: a guide to water sensitive urban design. Engineers Australia, Barton, pp 5-1–5-22
46. Dagerskog L, Coulibaly C, Ouandaogo I (2010) The emerging market of treated human excreta in Ouagadougou. In: UA magazine no 23 – Urban Nutrient Management, pp 45–48
47. Bahri A, Sally H, McCartney M, Namara R, Awulachew S, Van Koppen B, van Rooijen D (2011) Integrated urban watershed management: towards sustainable solutions in Africa. In: Garrido A, Ingram H (eds) Water for food in a changing world, Contributions from the Rosenberg International Forum on Water Policy. Routledge, London, pp 50–70
48. SWITCH (2011) SWITCH 2006–2011: managing water for the city of the future. UNESCO-IHE Global Partnership, [www.switchurbanwater.eu](http://www.switchurbanwater.eu). Accessed 4 Feb. 2016
49. Najjar KF, Collier R (2011) Integrated water resources management: bringing it all together. *Water Resour Impact* 13:3–8
50. Watson A, Prickett R, Taghavi A, West T (2011) California's IWRM program: a regional framework for integrated water resources management. *Water Resour Impact* 13:9–13
51. Bieker S, Cornel P, Wagner M (2010) Semi-centralised supply and treatment systems: integrated infrastructure solutions for fast growing urban areas. *Water Sci Technol* 61:2905–2913
52. Balanyá B, Brennan B, Hoedeman O, Kishimoto S, Terhorst P (2005) Reclaiming public water – achievements, struggles and visions from around the world. Corporate Europe Observatory, Amsterdam

# Index

## A

Aarhus, Denmark, 16, 22–24  
Agriculture, xiv, 60, 110, 185, 188, 236,  
239, 240, 244, 268–270, 272, 273,  
276–278, 283–285, 289, 298, 302,  
307, 310, 311  
Air conditioning, 59, 61, 62, 68, 71, 191  
Air filtration, 190, 195, 198  
Aluminium, 273, 274  
Ammonia/ammonium, 77, 108, 273  
runoff, 214  
Amsterdam, 3  
Arsenic, 227, 276  
Asphalt shingle roofs, 213–214

## B

Bangkok, Thailand, 304  
Bathing water, 3, 5, 23, 26–27  
directives, 5, 20, 23, 24  
safe, 26–27  
Beijing, xi, xii, xiii, 45, 48, 57–80, 226  
Best management practices (BMPs), 84,  
107–109, 112, 114, 118, 119, 127,  
224, 225  
Better Site Design (BSD), 94–97, 106, 107,  
116, 118  
Bicarbonates, 182, 186  
Biocides, 214  
Biodiversity, 126, 168, 171, 191, 238, 305  
Biological uptake, 107, 108  
Bioretention, 101, 107–112, 183, 220, 221,  
224, 227  
Bird droppings, 215  
Blacksburg, Virginia (USA), 36, 37

BMPs. *See* Best management practices (BMPs)  
Boron, 182, 186, 276  
BSD. *See* Better Site Design (BSD)  
Bulawayo, Zimbabwe, 276, 278–285

## C

Cadmium, 213, 274, 276, 280, 281, 283, 284  
Carbon dioxide (CO<sub>2</sub>), 24, 34–38, 46, 47, 49,  
50, 54, 181, 191, 228, 245, 249, 253,  
257, 258  
Carbon filter, 186, 219, 221, 223  
Carbon footprint, xi, xii, 33–54, 226  
Carbon monoxide, 168, 192  
Carbon storage, 310  
Catchments, cooperation across, 20–21  
Channels, design  
protection, 85, 87–93, 107, 115  
Chlorine, toxicity, 186  
Cholera, 27, 124, 270, 273, 275  
Chromium, 214, 219, 276  
Chusuido, 59  
Citizen awareness, 38  
Clean Water Act, 84, 85, 113  
Climate change, xi, xii, xiii, xiv, 1–31,  
170, 172, 183, 201, 259, 298,  
303–307, 323  
adaptation, 3, 4, 7–13, 15–22, 25, 28, 30  
Cogeneration, 42, 43  
Coliforms, 154, 217, 244, 275, 283, 284  
Collaboration, 112, 115, 152, 162, 285,  
319, 323  
Combined stormwater and sewage systems  
(CSOs), 306  
Comfort, 199–200

- Community gardens, 239, 241, 242, 246, 247, 249–253, 256, 258
- Conservation, development, 119
- Container gardens, 240
- Cooling effect, 171, 176, 191
- Copenhagen, bathing water, 26–27
- Copper, 154, 214, 219, 274, 276
- Crops, 128, 171, 173, 176, 179, 183, 189, 201, 210, 238, 240, 241, 243, 248–250, 258, 259, 268–271, 273, 274, 277–279, 281–285, 287, 288
- contamination, 248, 274
- irrigation, 183, 240, 243, 250
- D**
- Dakar, Senegal, 278
- Daylighting, 123, 127–131, 139, 141, 143, 144, 146, 148, 151, 157, 162, 163
- Decentralized systems, 45, 61, 320
- Decision support system (DSS), 173, 201, 313–315
- Demolition, 139, 140, 152, 157
- Desalination, 42, 49–52, 54, 228, 303, 304, 321
- Dhaka, Bangladesh, 27–31
- Diarrheal diseases, 27, 28
- Disease control, 28–30, 171
- Drainage, 10, 11, 17, 26, 28, 34, 40, 45, 58, 59, 61, 64, 68, 70, 71, 84–88, 93, 96, 99, 101, 104, 107, 110, 119, 123, 124, 127–129, 131, 132, 137, 138, 141, 151, 157, 158, 171, 174, 177–178, 183, 187, 201, 273, 311
- configuration, 177–178
- Drinking water, xiv, 8, 27, 28, 31, 37, 40–43, 45, 48, 50, 59, 118, 124, 128, 180, 210, 211, 213–215, 219, 226, 245, 268, 274, 304, 308, 319
- quality, 28, 226
- standards, 59, 213
- treatment, xiv, 42, 43, 50, 245
- utilities, energy conservation, 41–43
- DSS. *See* Decision support system (DSS)
- Dust, 60, 193, 194
- E**
- Economic benefits, 212, 217, 223, 226–228, 243, 277
- Ecosystem services, 168, 169, 198, 199, 238, 304, 305, 310
- provision, xiii, 189–197
- EGR. *See* Extensive green roof (EGR)
- Egypt, 210, 297, 311, 320–323
- Electricity, 35–38, 41, 43, 47, 49, 53, 58, 67, 227, 228, 245, 246, 248, 249, 301
- Energy, 23, 34, 57, 93, 152, 168, 212, 237, 298
- balance, xiii, 58, 196, 198–199
- conservation/saving, 38–44, 46–48, 50–54, 75–78, 179, 191, 196–198, 212, 225–226, 244, 248, 249, 257
- consumption, xi–xiii, 23, 34, 35, 38, 40, 42, 45, 48, 49, 53, 54, 57–80, 168, 172, 192, 196, 197
- efficiency, 34, 38, 40, 41, 43, 46–47, 49, 53, 59, 76, 221
- renewable, xii, 35, 38, 48–54
- Energy-use efficiency, 39–44, 53, 77, 198, 221
- Environmental assessment, 197–200
- Environmental health, 163, 194, 270
- Environmentally relevant behavior (ERB), 38
- Environmental risks, 273, 275–276, 285
- Erosion, 85, 88, 90, 93, 95, 111, 112, 114, 119, 131, 133, 135–140, 143, 149, 152, 154, 177, 201, 252, 305
- ETEC, 27
- Eutrophication, 273, 276
- Evapotranspiration, 89, 108, 171, 179, 182, 191, 237, 268, 299
- Extensive green roof (EGR), 197
- F**
- Fecal coliform, 154, 244, 283, 284
- Fertilizers, 276, 277, 317
- Filter strips, vegetated, 98, 99, 108, 109
- Filtration, 42, 45, 46, 101, 107–109, 186, 190, 225, 229, 245, 319
- air, 190, 192–195, 198
- pre-tank, 215, 216, 223
- sediment, 219, 221, 223
- Flooding, xii, xiii, 2, 3, 10, 12–14, 23, 25–27, 31, 85, 86, 90, 92, 93, 118, 119, 122, 128, 130, 138, 140, 142, 146, 148, 157, 163, 211, 246, 258, 303–306, 310
- Food security, xiv, 238, 247, 267–270, 276–278, 285, 308, 317
- Forest cover, loss, 106
- Fossil fuels, xiii, 34–38, 49, 53
- G**
- Gesuido, 59
- Globalization, 300
- Government subsidies, 227

Grass swales, 101–102, 107–109  
 Gray water, xi., 59, 170, 184, 185, 187, 214, 243, 319  
   regeneration, xiii, 185, 187  
 Greenhouse gas emissions, xiv, 228, 236, 237, 244, 245, 248, 253, 256–258, 303  
 Green infrastructures (GI), xii, xiii, 94, 95, 97, 110, 123, 126–127, 163, 168, 169, 188, 191, 195–198, 223  
 Green roofs, xii, xiii, 4, 45, 46, 104, 110, 167–202, 214–215, 250, 259  
   irrigation, 178–180, 187  
   regenerated water, 185–188  
 Greenspaces, xiv, 237–245  
 Greve, Denmark, 25–26  
 Groundwater, 3, 5, 8, 25, 48, 51, 103, 110, 118, 129, 130, 138, 182, 211, 212, 223–225, 228, 270, 271, 276, 302–306, 308, 323  
   contaminated, 138  
   decline, xi, 34, 225  
   preservation, 212, 225  
   recharge, 94, 95, 225, 237, 238, 272  
   source development, 40, 41  
 Growth triangles, 300

## H

Hamburg, 3, 6  
 Harbor Brook, HUB Redevelopment Site, Meriden, Connecticut (USA), 144–149  
 Haroonabad, Pakistan, 278  
 Heat island, 127, 168, 169, 171, 192, 198, 238  
 Heavy metals, 182, 213, 215, 217–219, 229, 244, 245, 272–274, 279–284, 287, 289  
 Ho Chi Minh City, Vietnam, 278  
 Home gardens, 239–241, 243, 246, 247, 249, 250, 252–254, 269  
 Hotels, xi–xiii, 39, 45, 48, 52, 53, 57–80  
 Human health, 2, 28, 186, 244, 248, 305  
 Hybrid production systems, 269  
 Hyderabad, India, 278

## I

Ibadan–Lagos–Cotonou–Lome–Accra corridor, 301  
 ICA. *See* Institutional capacity assessment (ICA)  
 IGR. *See* Intensive green roof (IGR)

Impervious cover, 87, 88, 93–97, 106, 114, 117, 119, 131, 132  
 Impervious surface disconnection, 99, 100, 109  
 Indian Creek, West Branch, Philadelphia, Pennsylvania (USA), 140–144  
 Infectious disease, waterborne, urban, 27–30  
 Infiltration, 89, 94, 99, 101, 103, 106–110, 112, 171, 173, 174, 176, 201, 223–225, 237, 299, 304  
   capacity, 88, 177, 179  
 Institutional capacity assessment (ICA), 315, 316  
 Integrated urban water management (IUWM), xi, xii, xiv, 1–31, 298, 307–308, 313–322  
 Intensive green roof (IGR), 197  
 International organizations, 311–312  
 Irrigation, 39, 59, 104, 169, 212, 240, 266, 297  
   infrastructure, 318  
   systems, 170–180, 183, 184, 186–188, 201  
   water, quality, 180–182  
 IUWM. *See* Integrated urban water management (IUWM); Urban water management, integrated (IUWM)

## J

Josuido, 59

## K

Karachi, Pakistan, 318  
 Kokkedal, 12–13

## L

Laws, 288, 289, 318  
 LCA. *See* Life cycle analysis (LCA)  
 LCC. *See* Life cycle cost (LCC)  
 LCI. *See* Life cycle inventory (LCI)  
 Lead (Pb), 139, 189, 191, 213–214, 218, 219, 227, 274, 276, 277, 280–284, 289  
 LID. *See* Low-impact development (LID)  
 Life cycle analysis (LCA), ix, 197, 198, 223, 227  
 Life cycle assessment, xii, xiv, 227–229  
 Life cycle cost (LCC), 104, 197  
 Life cycle inventory (LCI), 198  
 Little Sugar Creek, Kings Drive and Midtown Reaches, Charlotte, North Carolina (USA), 140, 149–155  
 London, 3, 124

- Low-impact development (LID), 93–95, 97, 106, 110–111, 123, 183, 211, 212, 223–225
- M**
- Manganese, 274, 276
- Manure, 317–318
- Marketing, 180, 270, 274, 288
- Membrane roofs, 215
- MENA region, xii, xiv, 296, 298, 307, 308, 311, 320, 322, 323
- Mercury, 154, 213–214, 274, 276
- Mexico, 278
- Microbial contaminants, 217–218, 229
- MIKE BASIN, 314–315
- Mitigation strategies, xi, xii, 38–54
- Mixed production systems, 269
- Monitoring, 6, 8, 23, 24, 26, 41, 114, 132, 137, 154, 163, 171, 186, 187, 220, 221, 225, 226, 284, 302, 304, 306, 318, 319  
real-time, 23, 24, 26
- N**
- Nairobi, 278, 289
- Nationwide Urban Runoff Program (NURP), 93
- Natural Resource Conservation Service (NRCS), 90–93
- Natural resource protection, 85, 93–95
- New York City, USA, 41, 196, 212, 319
- Nickel, 274, 276
- Nitrates, 108, 164, 182, 214, 273, 274, 281–283
- Nitrogen, 108, 163, 191, 192, 225, 272, 273, 275–277
- Noise pollution, 195–196
- NO<sub>x</sub>, 191, 192, 194
- NRCS. *See* Natural Resource Conservation Service (NRCS)
- NURP. *See* Nationwide Urban Runoff Program (NURP)
- O**
- Odense, 10–11
- Overlay zoning, 118
- P**
- PAHs. *See* Polycyclic aromatic hydrocarbons (PAHs)
- Paris, 3, 6, 220
- Particulate matter, 195, 197, 282  
removing capacity, 195
- Pave and drain, 84–87, 90–91, 94
- Pavement, permeable, 101, 102, 108–110
- Pesticides, 272, 309
- pH, 179–182, 186, 214, 273, 281, 284
- Phosphate, 276–277, 281–283, 317
- Phosphorus, 108, 225, 273, 276, 281
- Photovoltaic (PV) arrays, 49
- Policy responses, 310–311
- Polycyclic aromatic hydrocarbons (PAHs), 214, 244
- Population growth, 34, 127, 237, 267–269, 271, 308, 318
- Post-storage water quality/treatment, 217–219
- Potable water saving, 45–47, 220, 224–226
- Prestorage treatment, 215–216, 229
- Pre-tank filtration, 215, 216, 223
- Pretoria, Johannesburg, Witwatersrand and Vereeniging, 300
- Privatization, 312–313, 317, 321
- Pumps, 36, 37, 40–42, 44, 49, 51–53, 58, 67, 73, 75–78, 172, 180, 213, 219–221, 249, 277–278
- PV arrays. *See* Photovoltaic (PV) arrays
- R**
- Rainwater, 8, 40, 99, 124, 169, 209, 235, 300  
filtering, 216  
harvesting (RWH), 45, 99, 183, 209, 237, 304  
impacts, 223–228  
rainfall, runoff and green roofs, 183–185  
runoff volume, 224  
system design, 212–219  
water quality impacts, 225  
storage, 9, 215, 218, 220, 223, 227
- Real-time control and monitoring, 23, 24, 26
- Receiving stream health, 115
- Reclaimed water, 45, 57, 186
- Redevelopment, 93–94, 97–98, 110, 113, 116, 118–119, 127, 141, 144–149, 156, 298–299
- Red Sea, 321
- Regenerative Stormwater Conveyance (RSC) system, 103
- Renewable energy use, xii, 35, 38, 48–54
- Roanoke, VA USA, xii, xiv, 46, 47, 235–259
- Roofs, 4, 45, 104, 167, 210, 243, 304  
asphalt shingles, 213–214  
green, xii, xiii, 4, 45, 46, 106, 110, 167–202, 214–215, 250, 259



- membrane, 215
  - vegetated, 104–105, 108, 109
  - wood shingles, 214
- Rooftops, agriculture, 211, 243, 244, 258
  - characteristics, 213–215
- Rotavirus, 27
- Rotterdam, 3
- RSC system. *See* Regenerative Stormwater Conveyance (RSC) system
- Runoff, 20, 34, 84, 122, 168, 211, 237, 299
  - reduction, xii, 85, 97–110, 114, 217
  - volume, 87, 88, 91–94, 106, 107, 109–110, 114–115, 214, 223–225
- S**
- Safety coefficient, 66, 68–72
- Sanitation, 5, 28, 215, 236, 268, 271, 274, 298, 300, 301, 303, 304, 306–307, 312, 323
- Sedimentation, 73, 108, 114, 137, 245, 305
- Sediments, 88, 98, 103, 108, 111, 112, 114, 125, 126, 130, 133–137, 139, 153, 158, 172, 174, 176, 215, 216, 218–221, 223, 305
  - control, 111, 112, 139
  - filtration, 219, 223
- Selenium, 276
- Sewage treatment, 8, 22, 185, 273–274
- Sheet flow, 98–99, 109, 157
- Site planning, 85, 94–97, 101, 112, 116, 147
- Smart growth, 95–97, 116, 118
- Sodium, 182, 186, 276, 282, 283
  - adsorption ratio (SAR), 186, 282, 283
- Solar energy, 49–52
- SO<sub>x</sub>, 191–194
- Specialised production systems, 269
- Stakeholder integration, 15–16, 21, 30
- Stenløse, 13–14
- Storage tanks, 36, 64, 73, 104, 143, 147, 213, 215–218, 220, 221, 223, 224, 227, 228, 243
- Stormwater, 3, 34, 83, 122, 168, 211, 237, 271, 299
  - alternative, 128
  - management, xi, xii, xiii, 7, 11, 17, 19, 29–31, 83–119, 122, 123, 128, 191, 217, 223, 224, 227, 229, 306
  - practice, 85–94, 97, 107, 109
  - quality/quantity, 115–116
- Streams, 4, 42, 84, 121, 198, 237, 302
  - channel and flood protection, 85, 87–93
  - daylighting, xii, xiii, 121–164
  - receiving stream health, 115
  - restoration, xii, xiii, 121–164
- Sulfur, 182
- Sulfur dioxide, 168, 192
- Sustainable cities, 269, 316
- Sustainable urban water management (SUWM), 315, 316
- SUWM. *See* Sustainable urban water management (SUWM)
- Syria, 311, 322, 323
- T**
- Tank sizing, 228
- TARWR. *See* Total actual renewable water resources (TARWR)
- Tax breaks, 227
- Thermal regulation, 190–192
- Thermo-hygrometric index (THI), 200
- THI. *See* Thermo-hygrometric index (THI)
- TMDLs. *See* Total maximum daily loads (TMDLs)
- TN. *See* Total nitrogen (TN)
- Total actual renewable water resources (TARWR), 266–267
- Total maximum daily loads (TMDLs), 95, 114
- Total nitrogen (TN), 225
- Total phosphorus (TP), 225
- Total suspended solids (TSS), 225
- TP. *See* Total phosphorus (TP)
- TSS. *See* Total suspended solids (TSS)
- Typhoid, 27, 124, 275
- U**
- UHI. *See* Urban heat island (UHI)
- Urban agriculture, 45, 170, 211, 235, 266
- Urban biodiversity, 168
- Urban climate change adaptation, 11, 28, 30
- Urban corridors, 151, 300–301
- Urban farms, 172, 239, 240, 242, 243, 246–258, 276, 278, 285–288
- Urban flooding, 25–26, 140, 157, 163
  - management, 25, 26
- Urban greenspace, xiv, 237–244
- Urban heat island (UHI), 168, 169, 171, 199, 238
- Urban infrastructure, 36, 84, 89, 301
- Urbanization, 34, 93–94, 114, 168, 197, 225, 236, 237, 259, 297–308, 317, 322, 323
- Urban sprawl, 125, 301
- Urban streams, 84, 123–125, 127–128, 131, 135, 137, 139–141, 155, 162
  - daylighting, xii, xiii, 123, 127–132, 137, 139, 140

- Urban sustainability, 237–238, 240  
 Urban waterborne infectious disease, 29  
 Urban water cycle, xiii, 3, 169, 298, 299, 307, 315  
 Urban water management, integrated (IUWM), xi, xii, xiv, 1–31, 298, 307–308, 313–322  
 URV. *See* Usable rainwater volume (URV)  
 Usable rainwater volume (URV), 248, 250, 252–257, 259  
 Usserød River, 12–13  
 Utility planning, 118
- V**  
 Værebro River, 13  
 Vegetated filter strips, 98, 99, 108, 109  
 Vegetated roofs, 104–105, 108, 109
- W**  
 WASH sector. *See* Water, sanitation and hygiene (WASH) sector  
 Wastewater, 5, 34, 58, 85, 124, 170, 241, 265, 299  
   health risks, 272, 274–275  
   treatment facilities, 36, 40, 43–44, 50, 313  
 Water, balance analysis, 67–72  
   conservation, 68  
     in-building, 39  
   consumption, carbon footprint, 33–54  
   cycle, urban, 169, 298, 299, 307, 315  
   distribution network, 40, 42–43, 47–48  
   infrastructure, 34  
     decentralized, 34–35, 44–48, 52, 53  
   management, 1, 35, 61, 83, 122, 167, 213, 243, 265, 295  
   potable, xi, xiv, 34–37, 40, 45–48, 104, 163, 180, 187, 212, 217, 220, 223–228, 236, 237, 240, 242, 248, 249, 256, 272, 290, 301, 320–322  
   privatization, 312  
   quality monitoring, 26, 154, 163, 302  
   quality standards, xiii, 59–61, 114, 169, 180, 226, 245  
   reclaimed, xi, xiii, 45, 48, 57–80, 186, 188  
   recycling, 188, 320  
   regeneration systems, 186–187  
   regulation, 191, 198, 199  
   reuse, risks, 45, 47–48, 52–54, 59, 61–66, 70, 72, 185–188, 272, 276, 277, 320  
   source development, 40–41, 51–53  
   supply, alternative, xiii, 35, 40, 169, 183, 185, 186, 224, 241  
   treatment system, small-scale, advanced, 42, 47–49, 67, 76  
   utility energy-use efficiency, 39–44  
 Water Research Foundation (WRF), 39–41  
 Water resource information system (WRIS), 308, 309  
 Water, sanitation and hygiene (WASH) sector, 298  
 Watershed, assessment, 132–133  
   dynamics, 85  
 Watershed-based permitting, 115–116  
 Westerly Creek, Denver, Colorado (USA), 140, 155–162  
 Wind energy, 49, 51, 52  
 Wood shingle roofs, 214  
 WRF. *See* Water Research Foundation (WRF)  
 WRIS. *See* Water resource information system (WRIS)
- Z**  
 Zinc, 191, 213, 214, 219, 274, 276